

RAPTOR Coupling

BALDOR • DODGE®



RAPTOR
WORK

MADE IN THE U.S.A.



A Better Choice Has Arrived

Coupling maintenance and reliability should not monopolize your maintenance team. The Baldor•Dodge® Raptor Coupling eliminates these concerns.

The Raptor's easy to assemble, patented split natural rubber element significantly decreases total costs of ownership and extends driven equipment life. Built for drop-in interchangeability, the Raptor features an innovative design offering easier installation, reduced maintenance, and improved reliability in a wide range of new and existing applications.

The Baldor•Dodge Raptor: A better choice has finally arrived.



Elastomeric Coupling Innovation

**LONGER DRIVEN
EQUIPMENT LIFE**

**FLEXIBLE
MOUNTING OPTIONS**

**PATENTED WINGLOCK™
ELEMENT DESIGN**



**DROP-IN
INTERCHANGEABILITY**

**EASIER
INSTALLATION**

Designed and Developed at Baldor•Dodge

Patented WingLock™ Element Design

The Baldor•Dodge Raptor utilizes a patented finite-element optimized winged elastomeric element design. This WingLock technology increases surface area in the most critical regions of the element, resulting in higher bond strength, improved fatigue resistance, and longer life versus competitive designs.



Dodge Raptor Patented WingLock Technology

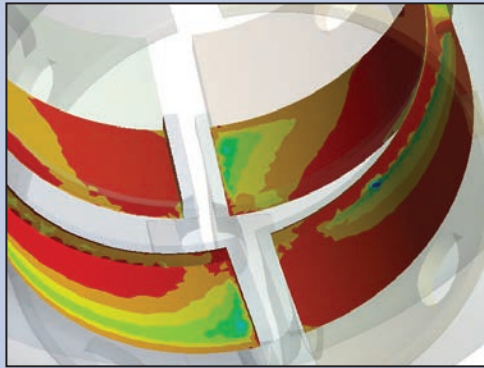

Pressure at bond without WingLock Technology

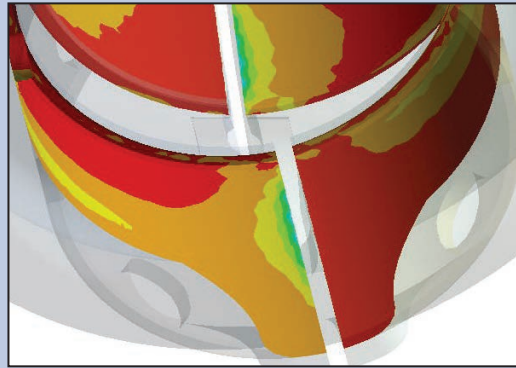

Pressure at bond with WingLock Technology

Documented Performance

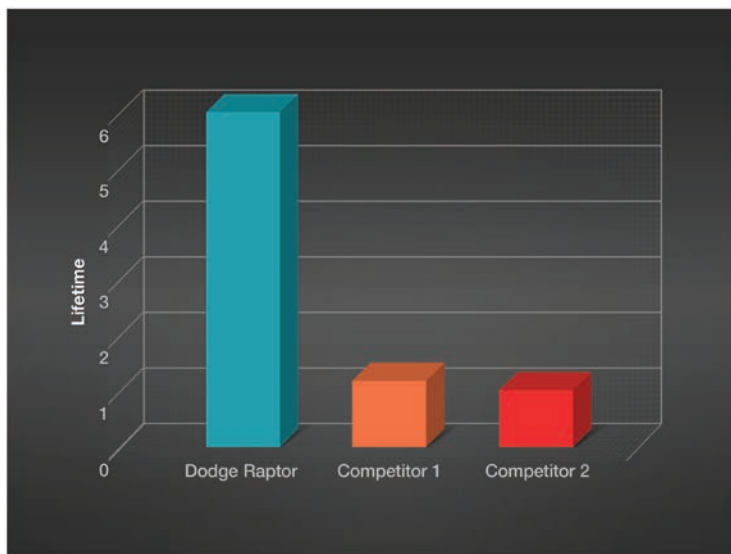

Average life, Baldor•Dodge Raptor versus competitors.

Comparative benchmark testing confirms the performance improvements associated with Raptor's WingLock element design. Even under worst-case misalignment and torque conditions, testing results show that the Raptor lasts six times longer than the closest competitor.

Results based on accelerated life testing at 1.5x catalog torque, while subject to 4° angular misalignment and 3/16" parallel misalignment.

Tested Tough

Engineers from Baldor’s Advanced Development Laboratory designed and tested the Raptor to perform under the most extreme conditions. This includes successfully passing the rigorous DIN 740 (reverse cyclic loading) coupling test standard – not once, not twice, but ten times for a single coupling.

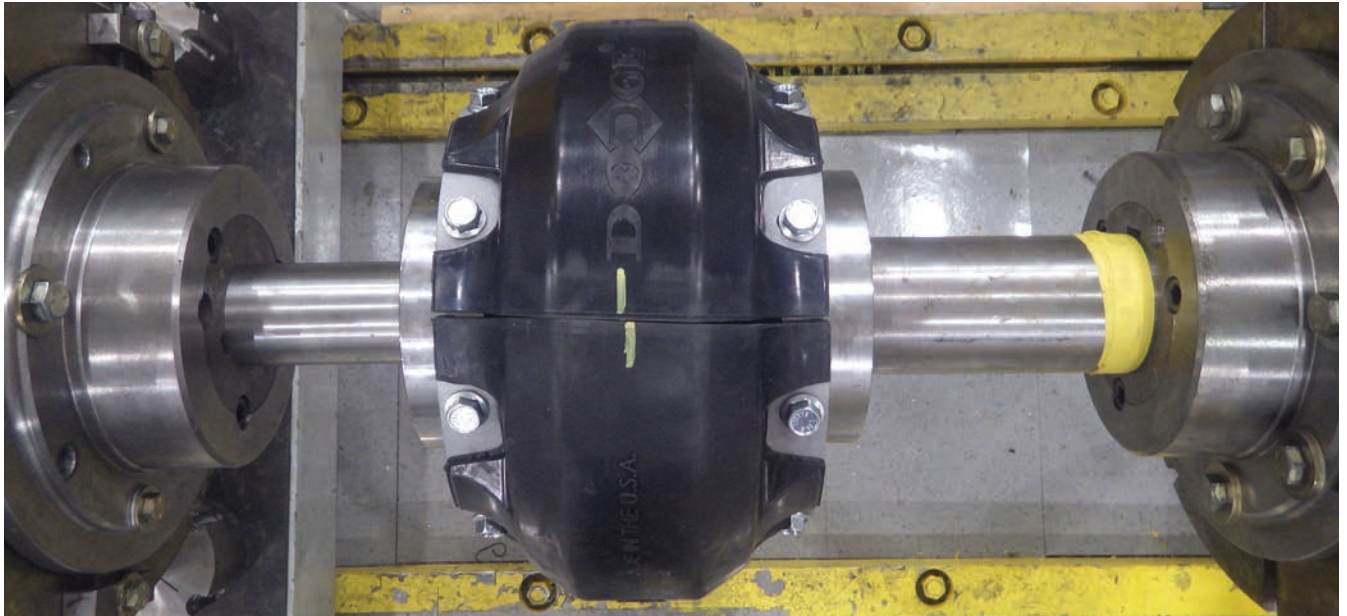

Immediately Increase Life in Existing Applications

Designed to be a drop-in interchange, the Raptor meets or exceeds torque, bore, and speed ratings for these styles of commonly used couplings. All Raptor components can be used in existing applications without any modifications. This allows current users of these styles to immediately realize the benefit of longer driven equipment life and improved reliability by switching to the Raptor.

Coupling Size

Baldor•Dodge Raptor	E2	E3	E4	E5	E10	E20	E30	E40	E50	E60	E70	E80	E100	E120	E140
Rexnord Omega	E2	E3	E4	E5	E10	E20	E30	E40	E50	E60	E70	E80	E100	E120	E140
TB Wood’s Dura-Flex	WE2	WE3	WE4	WE5	WE10	WE20	WE30	WE40	WE50	WE60	WE70	WE80	–	–	–

Industry Leading 5-Year Warranty

With over 100 years of coupling manufacturing experience, Dodge has a history of providing reliable coupling solutions in a wide range of industries and applications. Raptor couplings carry an industry leading 5-year Limited Warranty, even when used with competitors’ components.



Longer Driven Equipment Life and Improved Reliability

Superior Natural Rubber Element

Leveraging over 50 years of Dodge's natural rubber expertise, the Raptor features a natural rubber flexible element that offers a number of performance benefits when compared to competitive urethane designs.



- Static conductive for grounding redundancy, allowing current to safely pass through the natural rubber element, preventing the possibility of arcing during operation
- Exceptional resistance to hydrolysis, for improved performance in humid environments
- Superior thermal conductivity and ability to dissipate heat and hysteresis build up

Lower Stiffness, Longer Driven Equipment Life

Because the Raptor element uses a natural rubber compound, it is significantly more flexible than urethane designs. Natural rubber yields an element with approximately 50% lower torsional and bending stiffness, resulting in longer life for all types of connected driven equipment – including motors, pumps, compressors and gearboxes.

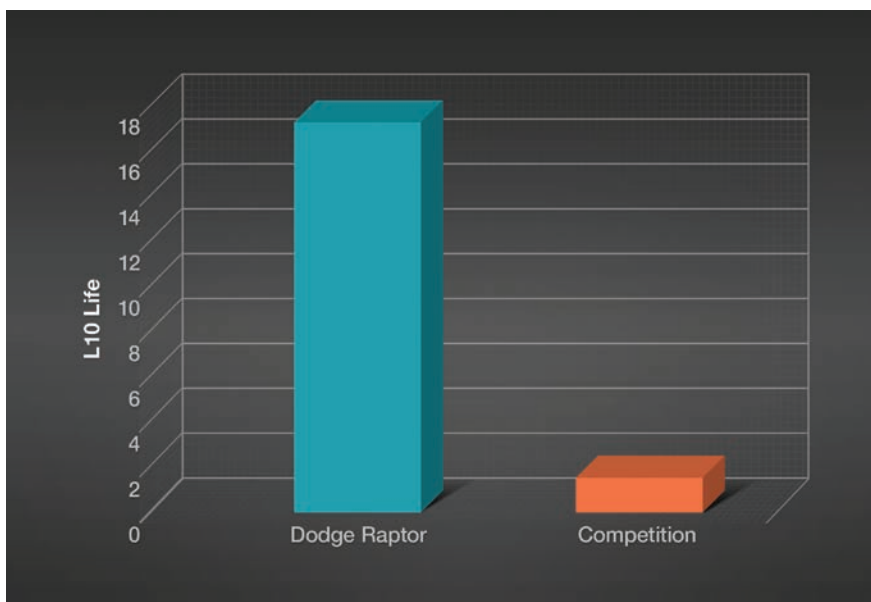

Connected equipment L₁₀ life, Baldor•Dodge Raptor versus competition

- Reduced bearing loads yield up to a 16.7 times increase in L₁₀ bearing life in connected equipment
- Less vibration transmission to connected equipment
- Better shock damping capabilities

Results based on tested bending stiffness values applied to a motor and centrifugal pump arrangement with 4° angular misalignment.

Industry Leading Misalignment Capabilities

Over time foundations settle, vibration occurs, and some level of misalignment may occur. While competitive urethane couplings can handle pure angular or parallel misalignment, their capabilities are greatly diminished in applications with combined angular and parallel misalignment. Unfortunately for the competition, combined misalignment is reality.

When an elastomeric coupling is misaligned during operation, cyclic stresses are created, generating heat in a phenomenon known as hysteresis. The Raptor's natural rubber element has superior heat dissipating capabilities

versus competitive urethane elements.

Additionally, the Raptor has a lower angular stiffness, allowing it to be more forgiving in misaligned conditions. These two features combined allow the Baldor•Dodge Raptor to offer industry leading misalignment capabilities.

The Raptor provides accommodation of shaft misalignment during installation, operation, and replacement better than competitive urethane elements.

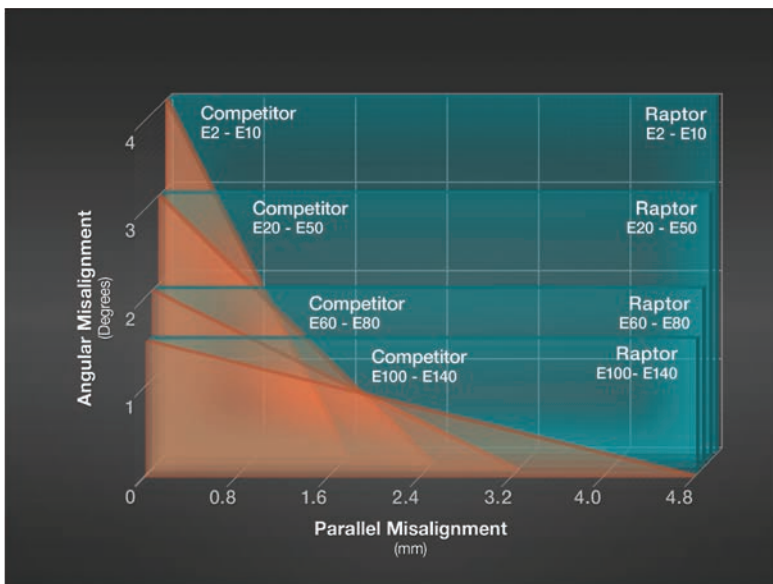

Attention to Every Detail

Baldor highly engineered every aspect of the Raptor for performance, including specification of high-strength Grade 8 flanged head cap screws. This robust hardware gives a 40% increase in proof strength versus competitor's standard head Grade 5 fasteners. Serrations under the flanged head and a thread locking patch help to resist loosening and minimize the potential for stripping. This attention to detail provides a more reliable connection between elastomeric element and shaft hubs.



Easier Installation and Reduced Maintenance

Improved Features, Easier Installation

The Dodge Raptor has everything needed for easier installations and reduced maintenance costs.

- Split element for easy replacement without moving and re-aligning connected equipment
- Slotted clamp ring holes offer 187% extra mounting hardware clearance versus competitor's circular through holes.
- Approximately 50% lower torsional stiffness makes the element significantly easier to manipulate by hand during installation
- Maintenance free non-lubricated natural rubber element for trouble-free operation

Raptor's slotted clamp rings offer more clearance at the bolt holes, for an easier installation than competitive designs.



Easy as 1-2-3

Installation for Dodge Raptor couplings are quick and easy. The Raptor's horizontally split element doesn't require locking shafts during installation, meaning a faster installation, requiring fewer tools and eliminating shaft damage. Simply fasten the shaft hubs, install the element, and tighten the hardware.



Step 1
Install Hubs



Step 2
Set Spacing



Step 3
Install Element

Suited For Any Application

A Practical Solution to Spacer Couplings

The innovation behind the Raptor coupling also extends to applications requiring additional space between shaft ends.

- One spacer element fits all standard ANSI and ISO spacer lengths
- Spacer elements can be replaced with standard close-coupled elements, resulting in lower replacement costs and reduced inventory
- Eliminates the need for high-speed rings, resulting in easier installation, while also reducing purchase costs and inventory requirements



Armored Elements for Extra Protection from Harsh Environments



Raptor elements are available with an optional Armored Element. This allows users to benefit from the increased performance and longer driven equipment life of standard Raptor elements, while providing an added layer of protection from ozone, petroleum oils, and some chemical environments. Raptor Armored Elements exceed ASTM 1149-07 rubber deterioration standards, as determined through third-party testing.



Third-Party ATEX Certified

When it comes to applications in hazardous environments, there's no reason for customers to assume any risk by using a product which is self-certified. That's why all Raptor couplings are third-party ATEX certified for worry-free use in hazardous environments. All required product markings and documentation are included with each coupling at no additional charge. When it comes to hazardous environments, you can trust Baldor•Dodge.

II 2 GD c T5 I M2 c

 Sira 15 ATEX 6170X 

DODGE RAPTOR COUPLINGS
MFG by Baldor Electric Company .
GREENVILLE, SC / FT. SMITH, AR USA

Shaft Hubs

Flexible Mounting Options for Any Application

- Available in a wide range of shaft attachment methods, including finished bore, Taper-Lock® and QD bushed options.
- Suited for any application, hubs are reversible to accommodate a wide range of shaft gaps
- Interchangeable hubs are used for both close-coupled and spacer designs for reduced inventory

Finished Bore

- Setscrew locking mechanism ensures a quick, easy installation
- Two setscrews at a 65° angle optimizes radial and torsional holding power, resulting in a 75% holding power increase versus competitive designs using one setscrew

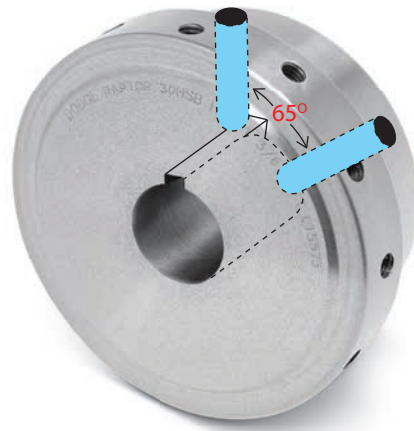

Taper-Lock® Bushed



- Reduced maintenance time and costs
- Easy installation and removal
- Minimal shaft damage
- Clean, compact design
- Dodge original design, an industry standard for over 50 years
- Conforms with MPTA-B9i-2013 Taper-Lock bushing standard
- Combine with Diamond Dodge <D> Integral Key bushings for added value and convenience

QD Bushed



- “Quick Detachable” QD bushings for easy installation and removal
- Reduced maintenance time and costs
- Minimal shaft damage
- Increased bore capacities
- Robust flanged design featuring capscrew hardware
- Conforms with MPTA-B6i-2010 QD bushing standard

How to Order

A complete Raptor coupling assembly consists of one element (standard or spacer) and two shaft hubs (finished bore, Taper-Lock®, or QD). If Taper-Lock or QD shaft hubs are selected, bushings must also be selected for the desired shaft size.

Nomenclature:

Elements:

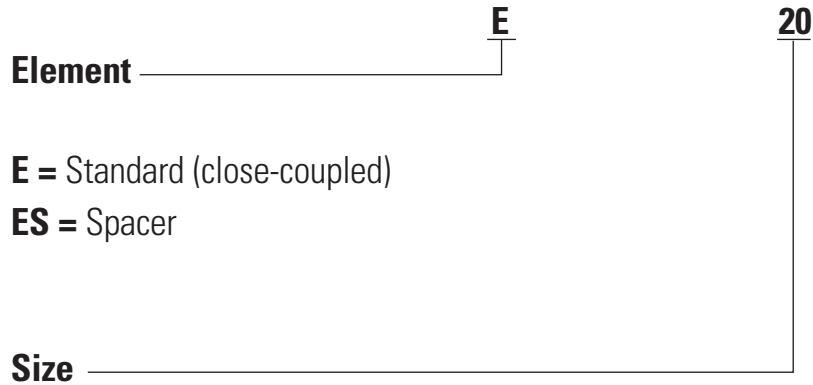

E = Standard (close-coupled)
ES = Spacer

Hubs:

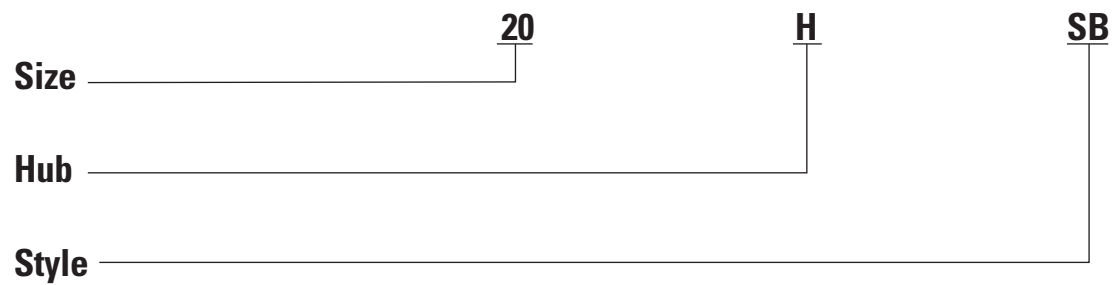

RB = Rough bore
SB = Finished bore (stock)
CB = Finished bore (custom)
CBMM = Custom Bore, Mill Motor
TL = Taper-Lock bushed
QD = QD bushed

Engineering

Selection Methods:

TORQUE METHOD:

Step 1: Obtain required service factor from Service Factor Tables on pages 14 and 15.

Step 2: Determine torque required for application.

$$\text{Torque (In - lbs)} = \frac{63025 \times \text{HP} \times \text{SF}}{\text{Coupling RPM}}$$

Step 3: From Rating Tables, find a rating equal to or greater than the torque. Note coupling size from left hand column.

Step 4: Check maximum RPM capability.

Step 5: Check maximum bore capacity. If maximum bore is exceeded, move to larger size with adequate bore. Be sure maximum RPM of coupling is not exceeded.

Notes:

1. If system peak torque is known and is non-reversing, start at Step 3. If system peak torque is known and reversing, multiply by 2.0 and start at Step 3.
2. If ambient temperature of the application is above 180°, a high temperature adjustment must be made to the system service factor. See page 29 (or 28, if the current page 28 is removed) for high temperature adjustment factors.
3. If spring set motor brake is used, and brake HP is greater than prime mover, use brake HP in place of motor HP.

HP/100 METHOD:

Step 1: Obtain required service factor from Service Factor Tables on pages 14 and 15.

Step 2: Determine the application HP per 100 RPM:

$$\text{HP} / 100 \text{ RPM} = \frac{\text{Motor HP} \times 100 \times \text{Service Factor}}{\text{Coupling RPM}}$$

Step 3: From Rating Tables, find a rating equal to or greater than HP design. Note to or greater than the HP/100 RPM. Note coupling size from left hand column.

Step 4: Check maximum RPM capability.

Step 5: Check maximum bore capacity. If maximum bore is exceeded, move to larger size with adequate bore. Be sure maximum RPM of coupling is not exceeded.

Service Factor
Table 1

Factor Δ	
Application (Read Footnotes)	Raptor
AGITATORS	
Paddle or Propeller (Vert. or Horiz.)	1.00
Screw	1.00
BLOWERS	
Centrifugal	1.00
Lobe	1.50
Vane	1.00
BREWING & DISTILLING	
Bottling Machinery, Brew Kettle	1.00
Cooker (Continuous Duty)	1.00
Mash Tub	1.00
Scale Hopper-Frequent Starting Peaks	1.50
CAN FILLING MACHINE	1.00
CAR DUMPER	1.50
CAR PULLER	1.50
CLARIFIER	1.00
CLASSIFIER	1.00
CLAY-WORKING MACHINES	
Brick Press, Briquette Mach., Clay Working Mach., Pug Mill	1.50
COMPRESSORS	
Centrifugal, Lobe, Screw	1.00
Lobe, Rotary**	2.00
Reciprocating**	
1 cylinder - single acting	3.50
1 cylinder - double acting	3.00
2 cylinder - single acting	3.00
2 cylinder - double acting	2.50
3 cl. or more - single acting	2.50
3 cl. or more - double acting	2.00
CONVEYORS	
Apron, Assembly, Belt, Chain, Flight, Oven	1.00
Reciprocating	2.50
Screw	1.00
CRANES AND HOISTS	
Main Hoist-Medium Duty	1.50
Main Hoist-Heavy Duty	2.00
Skip Hoist, Travel Motion, Trolley	1.50
Motion, Slope	1.50
CRUSHERS	
Cane	2.00
Gyratory	2.50

Factor Δ	
Application (Read Footnotes)	Raptor
DREDGES	
Cable Reel, Screen Drive, Stacker	1.50
Conveyor	1.50
Cutter Head Drive, Jig Drive	2.50
Pump, Utility Winch	1.50
DYNAMOMETER	1.00
ELEVATORS	
Bucket, Freight	2.00
EXCITER	1.00
FANS	
Centrifugal	1.00
Cooling Tower	2.00
Heavy Duty (Forced Draft)	1.50
Induced Draft	1.50
Light	1.00
Propeller Indoor	1.50
FOOD INDUSTRY	
Beet Slicer	1.50
Cereal Cooker	1.00
Dough Mixer, Meat Grinder	1.50
GENERATORS	
Even Load	1.00
Hoist or Railway Service	1.50
Welder Load	2.00
GRIZZLY	2.00
KILN	2.00
LAUNDRY MACHINES	
Tumbler Washer	2.00
LINE SHAFTS	
Driving Processing Machinery	1.00
Light	1.00
LUMBER INDUSTRY	
Band Resaw	1.50
Circular Resaw	1.50
Edger Head Rig, Hog, Log Haul	2.00
Planer	1.50
Rolls Non-Reversing	1.50
Rolls Reversing	2.00
Sawdust Conveyor	1.00
Slab Conveyor	1.50
Sorting Table	1.50
MACHINE TOOLS	
Auxiliary	1.00

Factor Δ	
Application (Read Footnotes)	Raptor
MACHINE TOOLS (continued)	
Main Drive	1.50
Notching Press, Planer (Reversing), Plate Planer, Punch Press	1.50
Traverse	1.00
METAL FORMING MACHINES	
Draw Bench, Carriage, Main Drive, Extruder,	2.00
Wire Drawing, Flattening Machine	2.00
MILLS Rotary Type	
Ball or Pebble direct or	2.50
on LS Shaft Gear Reducer	2.50
on HS Shaft Gear Reducer	2.00
Dryer and Cooler	1.50
Rod or Tube direct or	2.50
on LS Shaft Gear Reducer	2.50
on HS Shaft Gear Reducer	2.00
Tumbling Barrel	1.50
MIXERS	
Concrete (Continuous or intermittent)	1.50
Muller-Simpson type	1.50
OIL INDUSTRY	
Chiller	1.00
Oil Well Pumping (Not over 150% peak torque)	2.00
Paraffin Filter Press	1.50
PAPER MILLS	
Agitator	1.00
Barking Drum	2.50
Beater and Pulper	1.50
Bleacher	1.00
Calender	2.00
Chipper	3.00
Couch Cylinder Dryer	1.50
Felt Stretcher	1.00
Fourdrinier	1.50
Jordan	2.00
Press	2.00
Pulp Grinder	2.00
Stock Chest	1.50
Stock Pump	
Reciprocating	2.00

Service Factor

Table 1 (continued)

Factor Δ	
Application (Read Footnotes)	Raptor
PAPER MILLS (continued)	
Suction Roll	2.00
Winder	1.50
PARAFFIN FILTER PRESS	1.50
PRINTING PRESS	1.50
PROPELLER Marine	1.50
PULLERS	
Barge Hall	2.50
PULVERIZERS	
Hammermill-Light Duty	1.50
Hammermill-Heavy Duty	2.00
Hog	2.00
Roller	1.50
PUMPS	
For Stock Pumps See Paper Mills	
Centrifugal	1.00
Descaling Gear Type	1.50
Oil Well Pumping (Not over 150% peak torque)	2.00
Rotary - other than gear	1.50
Reciprocating	
1 cylinder-single acting	2.50
1 cylinder-double acting	2.00

Factor Δ	
Application (Read Footnotes)	Raptor
2 cylinder-single acting	2.00
2 cylinder-double acting	1.50
3 cylinder or more	1.50
RUBBER INDUSTRY	
Banbury Mixer	2.50
Calender	2.00
Cracker Mixing Mill Plasticator	2.50
Refiner, Sheeter	2.00
Tire-Building Machine	2.00
Tire and Tube Press Opener Based on Peak Torque	1.00
Tuber and Strainer	1.50
Warming Mill	2.00
Washer	2.50
SCREENS	
Air Washing	1.00
Coal and Sand Rotary	1.50
Vibrating	2.50
Water	1.00
SEWAGE DISPOSAL EQUIPMENT	1.00
SHOVEL	2.00
SHREDDER	1.50

Factor Δ	
Application (Read Footnotes)	Raptor
STEEL INDUSTRY	
Cold Mills	
Coiler up or down	1.50
Strip, Temper	2.00
Hot Mills	
Coiler up or down	1.50
Edger Drive	1.50
Feed Roll Blooming	3.00
Roughing Mill Delivery	3.00
Non-reversing, Sheet Strip	3.00
Rod Mill	2.50
Soaking Pit Cover Drive Lift	3.00
Soaking Pit Cover Drive Travel	3.00
Rollout Table (non-reversing)	2.0
Rollout Table (reversing)	3.5
STEERING GEAR	1.00
STOKER	
TEXTILE MILLS	
Batcher	1.00
"Calender, Card Machine, D Can"	1.50
Dyeing Machine	1.00
Loom	1.50
Mangel, Napper, Soaper	1.00
Spinner, Tenter Frame	1.50
WINDLASS	1.50
WOODWORKING MACHINES	1.00

SYSTEM SERVICE FACTOR CALCULATION

To determine the system service factor, the driver service factor adder (Table 1A) must be added to the driven service factor. (Table 1) Example: Determine the system service factor for a Raptor coupling used to couple a barking drum and a six-cylinder diesel engine.

$$\text{Driven S.F.} + \text{Driver S.F. Adder} = \text{System S.F.}$$

$$2.5 + .5 = 3.0$$

- Δ The service factors listed are intended only as a general guide. Where substantial shock occurs or starting and stopping is frequent as on some "inching" drives and on some reversing drives or where the power source is an internal combustion engine with less

than four cylinders - Consult Dodge®. Where torsional vibrations occur as in, for example, internal combustion engine or reciprocating compressor or pump applications, check the coupling stiffness for the possible development of damaging large-amplitude vibrations. A complete system torsional analysis may be necessary.

** Add 0.5 to factor if without flywheel

◆ CONSULT DODGE FOR SELECTION ASSISTANCE

Table 1A-Driver Service Factor Adders

Type of Coupling	Electric Motor Std. Torque	High Torque Motors	Turbines	Reciprocating Engine Number of Cylinders				
				12 or More	8 to 11	6 to 7	4 to 5	Less than 4
Raptor	0.00	0.00	0.00	0.00	0.50	0.50	0.50	◆

Ratings & Dimensions Close-Coupled - Finished Bore

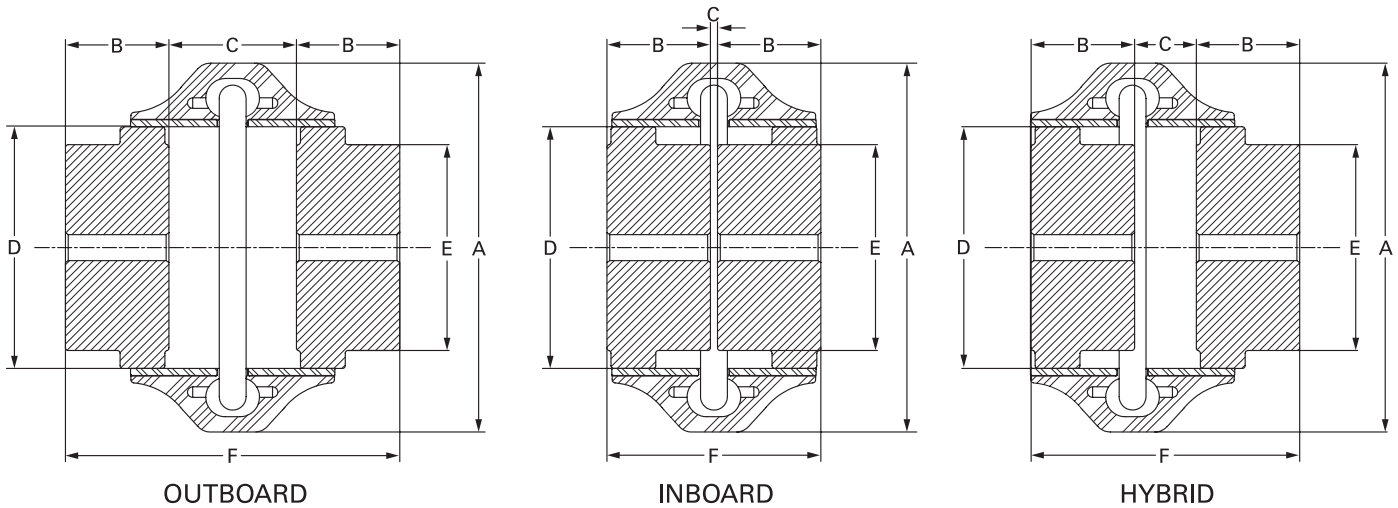

Coupling Size	Min. Bore	Max. Bore ¹	HP/100	Max Torque (In-Lbs)	Max. RPM	A	B	C			D	E	F			Weight ⁽²⁾ (Lbs.)
								Outboard	Inboard	Hybrid			Outboard	Inboard	Hybrid	
E2	–	1.13	0.31	194	7,500	3.50	0.94	1.90	1.34	1.62	1.85	1.65	3.78	3.22	3.50	1.2
E3	–	1.38	0.59	371	7,500	4.00	1.50	1.34	0.78	1.06	2.32	2.00	4.34	3.78	4.06	2.3
E4	–	1.63	0.89	558	7,500	4.56	1.69	1.34	0.42	0.88	2.60	2.36	4.70	3.78	4.24	3.3
E5	–	1.88	1.47	926	7,500	5.38	1.75	1.84	0.78	1.31	3.13	2.80	5.34	4.28	4.81	5.4
E10	–	2.13	2.31	1,456	7,500	6.38	1.88	1.84	0.52	1.18	3.65	3.30	5.60	4.28	4.94	7.6
E20	0.75	2.38	3.66	2,308	6,600	7.25	2.06	2.46	0.42	1.44	4.48	4.00	6.58	4.54	5.56	12.7
E30	0.75	2.88	5.79	3,651	5,800	8.25	2.31	2.55	0.45	1.50	5.42	4.62	7.17	5.07	6.12	19.7
E40	0.75	3.38	8.73	5,504	5,000	9.50	2.50	2.83	0.43	1.63	6.63	5.75	7.83	5.43	6.63	33.5
E50	1.13	3.63	12.1	7,656	4,200	11.00	2.75	3.47	0.53	2.00	8.13	6.13	8.97	6.03	7.50	50.9
E60	1.13	4.00	19.8	12,505	3,800	12.50	3.25	3.63	0.49	2.06	8.75	6.50	10.13	6.99	8.56	71.3
E70	1.38	4.50	35.1	22,132	3,600	14.00	3.62	4.00	0.52	2.26	9.25	6.99	11.24	7.76	9.50	82.0
E80	1.63	6.00	62.7	39,503	2,000	16.00	4.87	5.87	–	2.88	11.25	9.49	15.61	–	12.62	169.4
E100	2.50	6.75	135.0	85,085	1,900	21.00	5.50	3.77	1.77	3.02	14.13	10.51	14.77	12.77	13.77	252.6
E120	2.88	7.50	270.0	170,170	1,800	25.00	6.00	4.90	2.26	3.58	17.63	11.76	16.90	14.26	15.58	419.4
E140	3.25	9.00	540.0	340,340	1,500	30.00	7.00	5.02	3.02	4.02	20.88	15.01	19.02	17.02	18.02	593.4

(1) Consult page 32 for larger bore capacities with shallow keys

(2) Weight of complete coupling in pounds

(3) All dimensions in inches

Close-Coupled Inch Element Assemblies

Size	Standard (Natural Rubber)	Armored Elements	Replacement Hardware
E2	015843	017126	017000
E3	015844	017127	017001
E4	015845	017128	
E5	015846	017129	
E10	015847	017130	017180
E20	015848	017131	017002
E30	015849	017132	
E40	015850	017133	017003
E50	015851	017134	
E60	015852	017135	
E70	015853	017136	
E80	015854	017137	017004
E100	015931	017138	
E120	015932	017139	017006
E140	015933	017140	017007

(1) Element assemblies include hardware.

(2) Raptor elements are also available with metric hardware. This requires use of shaft hubs tapped for metric hardware. Reference International Couplings Catalog (ICA4004) or contact Baldor for more information.

Ratings & Dimensions Spacer - Finished Bore

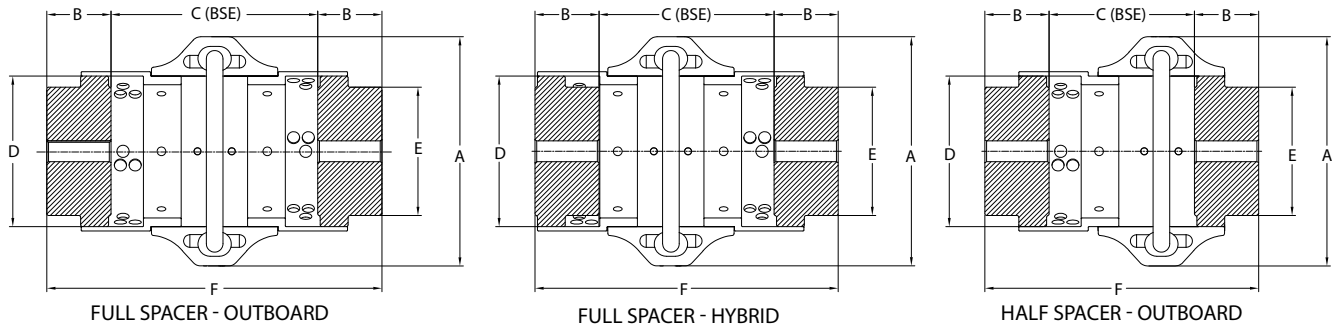

Coupling Size	Min. Bore	Max. ⁽¹⁾ Bore	HP/100	Max Rated Torque (In-Lbs.)	Max. RPM	A	B	C		D	E	F		Weight ⁽²⁾ (Lbs.)
								Min.	Max.			Min.	Max.	
ES2	—	1.13	0.31	194	7,500	3.50	0.94	2.51	3.94	1.85	1.65	4.39	5.82	1.86
ES3	—	1.38	0.59	371	7,500	4.00	1.50	2.14	5.51	2.32	2.00	5.54	8.51	3.73
ES4	—	1.63	0.89	558	7,500	4.56	1.69	1.96	5.51	2.60	2.36	5.54	8.87	5.12
ES5	—	1.88	1.47	926	7,500	5.38	1.75	2.14	5.51	3.13	2.80	5.80	9.01	7.78
ES10	—	2.13	2.31	1,456	7,500	6.38	1.88	2.01	5.51	3.65	3.30	5.77	9.27	10.35
ES20	0.75	2.38	3.66	2,308	6,600	7.25	2.06	2.70	7.29	4.48	4.00	6.90	11.41	17.31
ES30	0.75	2.88	5.79	3,651	5,800	8.25	2.31	2.45	7.46	5.42	4.62	7.12	12.08	26.81
ES40	0.75	3.38	8.73	5,504	5,000	9.50	2.50	2.74	7.55	6.63	5.75	7.74	12.55	43.57
ES50	1.13	3.63	12.1	7,656	4,200	11.00	2.75	3.27	8.72	8.13	6.13	8.77	14.22	63.98
ES60	1.13	4.00	19.8	12,505	3,800	12.50	3.25	3.43	10.60	8.75	6.50	9.93	17.10	94.85
ES70	1.38	4.50	35.1	22,132	3,600	14.00	3.62	3.76	10.80	9.25	6.99	11.00	18.04	106.34
ES80	1.63	6.00	62.7	39,503	2,000	16.00	4.87	5.12	15.80	11.25	9.49	14.94	25.54	207.47

- (1) Consult page 32 for larger bore capacities with shallow keys
- (2) Weight of complete coupling at maximum bore with four spacer extensions
- (3) All dimensions in inches

Finished Bore Spacer Lengths

Size	Standard (Natural Rubber) Element Part Numbers		Armored Elements		ANSI (in.)				ISO & DIN (mm)			
	Full Spacer	Half Spacer	Full Spacer	Half Spacer	3.5	5	7	10	100	140	180	250
ES2	017064	017182	017156	017218								
ES3	017065	017183	017157	017219								
ES4	017066	017184	017158	017220								
ES5	017067	017185	017159	017221								
ES10	017068	017186	017160	017222								
ES20	017069	017187	017161	017223								
ES30	017070	017188	017162	017224								
ES40	017071	017189	017163	017225								
ES50	017072	017190	017164	017226								
ES60	017073	017191	017165	017227								
ES70	017074	017192	017166	017228								
ES80	017075	017193	017167	017229								

- (1) Element assemblies include hardware.
- (2) Table shows actual spacer lengths relative to standard ANSI and ISO spacer lengths
- (3) All calculations based off of outboard hubs.

- Full Spacer Outboard Method
- Full Spacer Hybrid Method
- Half Spacer Outboard Method
- Half Spacer Hybrid Method

Hub Part Numbers

Finished Bore - Inch Bores

Bore (in.)	Coupling Size														
	2	3	4	5	10	20	30	40	50	60	70	80	100	120	140
Reborable	015234	015235	015236	015237	015238	015239	015240	015241	015242	015243	015244	015245	015246	015247	015248
1/2"	015425	015436	015451	015474	015501										
9/16"	015426	015437	015452	015475	015502										
5/8"	015427	015438	015453	015476	015503										
11/16"	015428	015439	015454	015477	015504										
3/4"	015429	015440	015455	015478	015505	015532	015563	015602							
13/16"	015430	015441	015456	015479	015506	015533	015564	015603							
7/8"	015431	015442	015457	015480	015507	015534	015565	015604							
15/16"	015432	015443	015458	015481	015508	015535	015566	015605							
1"	015433	015444	015459	015482	015509	015536	015567	015606							
1-1/16"	015434	015445	015460	015483	015510	015537	015568	015607							
1-1/8"	015435	015446	015461	015484	015511	015538	015569	015608	015649	015694					
1-3/16"		015447	015462	015485	015512	015539	015570	015609	015650	015695					
1-1/4"		015448	015463	015486	015513	015540	015571	015610	015651	015696					
1-5/16"		015449	015464	015487	015514	015541	015572	015611	015652	015697					
1-3/8"		015450	015465	015488	015515	015542	015573	015612	015653	015698	015749				
1-7/16"			015466	015489	015516	015543	015574	015613	015654	015699	015750				
1-1/2"			015467	015490	015517	015544	015575	015614	015655	015700	015751				
1-9/16"			015468	015491	015518	015545	015576	015615	015656	015701	015752				
1-5/8"			015469	015492	015519	015546	015577	015616	015657	015702	015753	015867			
1-11/16"				015493	015520	015547	015578	015617	015658	015703	015754	015868			
1-3/4"				015494	015521	015548	015579	015618	015659	015704	015755	015869			
1-13/16"				015495	015522	015549	015580	015619	015660	015705	015756	015870			
1-7/8"				015496	015523	015550	015581	015620	015661	015706	015757	015871			
1-15/16"					015524	015551	015582	015621	015662	015707	015758	015872			
2"					015525	015552	015583	015622	015663	015708	015759	015873			
2-1/16"					015526	015553	015584	015623	015664	015709	015760	015874			
2-1/8"					015527	015554	015585	015624	015665	015710	015761	015875			
2-3/16"						015555	015586	015625	015666	015711	015762	015876			
2-1/4"						015556	015587	015626	015667	015712	015763	015877			
2-5/16"						015557	015588	015627	015668	015713	015764	015878			
2-3/8"						015558	015589	015628	015669	015714	015765	015879			
2-7/16"							015590	015629	015670	015715	015766	015880			
2-1/2"							015591	015630	015671	015716	015767	015881	015010		
2-9/16"							015592	015631	015672	015717	015768	015882	015011		
2-5/8"							015593	015632	015673	015718	015769	015883	015012		
2-11/16"							015594	015633	015674	015719	015770	015884	015013		
2-3/4"							015595	015634	015675	015720	015771	015885	015014		
2-13/16"							015596	015635	015676	015721	015772	015886	015015		
2-7/8"							015597	015636	015677	015722	015773	015887	015016	015075	
2-15/16"								015637	015678	015723	015774	015888	015017	015076	
3"								015638	015679	015724	015775	015889	015018	015077	
3-1/16"								015639	015680	015725	015776	015890	015019	015078	
3-1/8"								015640	015681	015726	015777	015891	015020	015079	
3-3/16"								015641	015682	015727	015778	015892	015021	015080	
3-1/4"								015642	015683	015728	015779	015893	015022	015081	015146
3-5/16"								015643	015684	015729	015780	015894	015023	015082	015147
3-3/8"								015644	015685	015730	015781	015895	015024	015083	015148
3-7/16"									015686	015731	015782	015896	015025	015084	015149
3-1/2"									015687	015732	015783	015897	015026	015085	015150

 Stock bores

- Listed shaft hubs are tapped for imperial hardware, and intended for use with Imperial element assemblies. Shaft hubs and element assemblies are also available for use with metric hardware. Reference International Catalog (ICA4004) or contact Baldor•Dodge for more information.
- Unless otherwise specified, finished bores for sizes E2-E60 are Class 1 clearance fit and sizes E70-E140 are interference fit per AGMA 9002. See page 27 for additional details.

Finished Bore - Inch Bores (Cont.)

Bore (in.)	Coupling Size														
	2	3	4	5	10	20	30	40	50	60	70	80	100	120	140
3-9/16"									015688	015733	015784	015898	015027	015086	015151
3-5/8"									015689	015734	015785	015899	015028	015087	015152
3-11/16"										015735	015786	015900	015029	015088	015153
3-3/4"										015736	015787	015901	015030	015089	015154
3-13/16"										015737	015788	015902	015031	015090	015155
3-7/8"										015738	015789	015903	015032	015091	015156
3-15/16"										015739	015790	015904	015033	015092	015157
4"										015740	015791	015905	015034	015093	015158
4-3/16"											015792	015906	015035	015094	015159
4-1/4"											015793	015907	015036	015095	015160
4-3/8"											015794	015908	015037		
4-7/16"											015795	015909	015038	015096	015161
4-1/2"											015796	015910	015039	015097	015162
4-11/16"												015911	015040	015098	015163
4-3/4"												015912	015041	015099	015164
4-7/8"												015913	015042	015100	015165
4-15/16"												015914	015043	015101	015166
5"												015915	015044	015102	015167
5-3/16"												015916	015045	015103	015168
5-1/4"												015917	015046	015104	015169
5-7/16"												015918	015047	015105	015170
5-1/2"												015919	015048	015106	015171
5-11/16"												015920	015049	015107	015172
5-3/4"												015921	015050	015108	015173
5-7/8"														015109	015174
5-15/16"												015922	015051	015110	015175
6"												015923	015052	015111	015176
6-3/16"													015053	015112	015177
6-1/4"													015054	015113	015178
6-7/16"													015055	015114	015179
6-1/2"													015056	015115	015180
6-11/16"													015057	015116	015181
6-3/4"													015058	015117	015182
6-15/16"														015118	015183
7"														015119	015184
7-3/16"														015120	015185
7-1/4"														015121	015186
7-7/16"														015122	015187
7-1/2"														015123	015188
7-11/16"															015189
7-3/4"															015190
7-15/16"															015191
8"															015192
8-3/16"															015193
8-1/4"															015194
8-7/16"															015195
8-1/2"															015196
8-11/16"															015197
8-3/4"															015198
8-15/16"															015199
9"															015200

 Stock bores

- Listed shaft hubs are tapped for imperial hardware, and intended for use with Imperial element assemblies. Shaft hubs and element assemblies are also available for use with metric hardware. Reference International Catalog (ICA4004) or contact Baldor•Dodge for more information.
- Unless otherwise specified, finished bores for sizes E2-E60 are Class 1 clearance fit and sizes E70-E140 are interference fit per AGMA 9002. See pages 27-30 for additional details.

Hub Part Numbers

Finished Bore - Metric Bores

Bore (in.)	Coupling Size														
	2	3	4	5	10	20	30	40	50	60	70	80	100	120	140
11	016225	016236	016250	016267	016286										
12	016226	016237	016251	016268	016287										
14	016227	016238	016252	016269	016288										
16	016228	016239	016253	016270	016289										
17	016229	016240	016254	016271	016290										
18	016230	016241	016255	016272	016291										
19	016231	016242	016256	016273	016292	016307	016325	016347							
20	016232	016243	016257	016274	016293	016308	016326	016348							
22	016233	016244	016258	016275	016294	016309	016327	016349							
24	016234	016245	016259	016276	016295	016310	016328	016350							
25	016235	016246	016260	016277	016296	016311	016329	016351							
28		016247	016261	016278	016297	016312	016330	016352	016372	016393					
30		016248	016262	016279	016298	016313	016331	016353	016373	016394					
32		016249	016263	016280	016299	016314	016332	016354	016374	016395					
35			016264	016281	016300	016315	016333	016355	016375	016396	016416				
38			016265	016282	016301	016316	016334	016356	016376	016397	016417				
40			016266	016283	016302	016317	016335	016357	016377	016398	016418	016438			
42				016284	016303	016318	016336	016358	016378	016399	016419	016439			
45				016285	016304	016319	016337	016359	016379	016400	016420	016440			
48					016305	016320	016338	016360	016380	016401	016421	016441			
50					016306	016321	016339	016361	016381	016402	016422	016442			
55						016322	016340	016362	016382	016403	016423	016443			
56						016323	016341	016363	016383	016404	016424	016444			
60						016324	016342	016364	016384	016405	016425	016445			
63							016343	016365	016385	016406	016426	016446	016468		
65							016344	016366	016386	016407	016427	016447	016469		
70							016345	016367	016387	016408	016428	016448	016470		
71							016346	016368	016388	016409	016429	016449	016471		
75								016369	016389	016410	016430	016450	016472	016496	
80								016370	016390	016411	016431	016451	016473	016497	
85								016371	016391	016412	016432	016452	016474	016498	
90									016392	016413	016433	016453	016475	016499	
95										016414	016434	016454	016476	016500	016526
100										016415	016435	016455	016477	016501	016527
105											016436	016456	016478	016502	016528
110											016437	016457	016479	016503	016529
120												016458	016480	016504	016530
125												016459	016481	016505	016531
130												016460	016482	016506	016532
140												016461	016483	016507	016533
150												016462	016484	016508	016534

• Listed shaft hubs are tapped for imperial hardware, and intended for use with Imperial element assemblies. Shaft hubs and element assemblies are also available for use with metric hardware. Reference International Catalog (ICA4004) or contact Baldor•Dodge for more information.
 • Unless otherwise specified, finished bores for E2-E60 are transitional fit and sizes E70-E80 are interference fit per ISO R775. See page 31 for details.

Ratings & Dimensions, Mill Motor

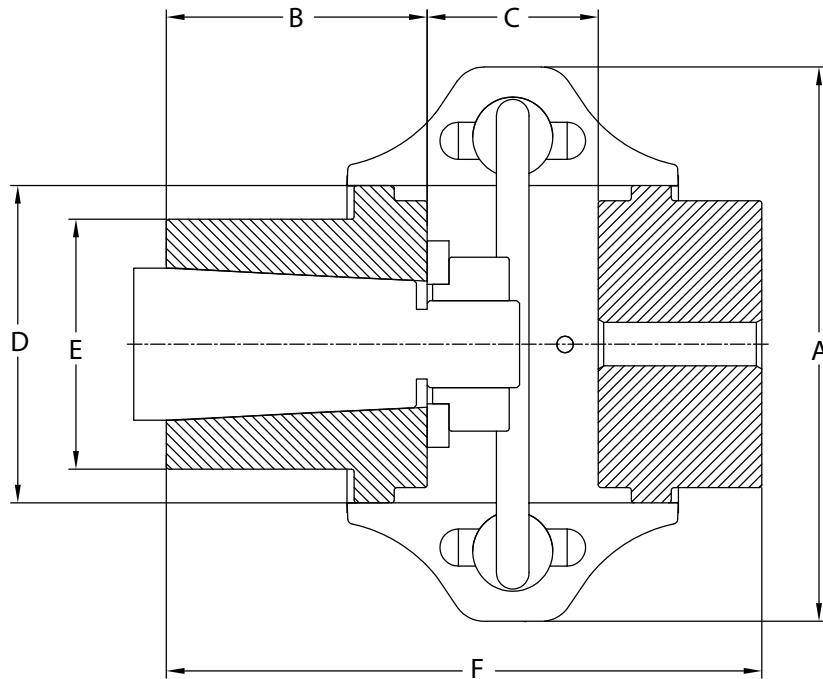

Mill Motor Hubs - HCBMM

Size	Mill Motor Size	HP/100	Max Rated Torque (In-Lbs.)	Max. RPM	A	B	C	D	E	F	Weight (Lbs.)	Description	Part Number
E10	602/802	2.31	1,456	7,500	6.38	3.00	1.81	3.65	2.88	6.68	5.8	10HMMCB - 602/802	017088
E20	802B/802C	3.66	2,308	6,600	7.25	3.00	2.38	4.48	3.00	7.44	9.8	20HMMCB - 802	017089
	603					3.50				7.94	9.1	20HMMCB - 603	017090
E30	603/803, 604/804	5.79	3,651	5,800	8.25	3.50	2.44	5.42	3.50	8.25	15.8	30HMMCB - 603/803 604/804	017091
E40	604/804	8.73	5,504	5,000	9.50	3.50	2.68	6.63	3.50	8.68	26.0	40HMMCB - 604/804	017092
E50	406/606/806	12.15	7,656	4,200	11.00	4.00	3.38	8.13	4.00	10.13	39.8	50HMMCB - 406/606/806	017093
	408/608/808									10.63	36.0	50HMMCB - 408/608/808	017094
E60	406/606/806	19.84	12,505	3,800	12.50	4.00	3.44	8.75	4.50	10.69	58.2	60HMMCB - 406/606/806	017095
	408/608/808									11.19	54.8	60HMMCB - 408/608/808	017096
E70	408/608/808	35.12	22,132	3,600	14.00	4.50	3.75	9.25	4.75	11.88	61.0	70HMMCB - 408/608/808	017097
	410/610/810									58.4	70HMMCB - 410/610/810	017098	
	412/612/812									12.38	54.4	70HMMCB - 412/612/812	017099
E80	410/610/810	62.68	39,503	2,000	16.00	4.50	5	11.25	6.00	14.38	118.0	80HMMCB - 410/610/810	017100
	412/612/812					115.3				80HMMCB - 412/612/812	017101		
	614					106.1				80HMMCB - 614	017102		
E100	612/812	134.96	85,057	1,900	21.00	5.00	3.75	14.13	10.25	14.25	216.6	100HMMCB - 612/812	017103
	614/814									207.4	100HMMCB - 614/814	017104	
	616/816									14.75	208.3	100HMMCB - 616/816	017105
	618/818									15.25	207.5	100HMMCB - 618/818	017106
E120	818	269.91	170,109	1,800	25.00	6.00	4.88	17.63	11.75	16.88	366.3	120HMMCB - 818	017107
	620									17.63	357.3	120HMMCB - 620	017108
E140	622	539.80	340,209	1,500	30.00	7.25	5	20.88	15.00	19.25	504.2	140HMMCB - 622	017109
	624					9.25				21.25	537.3	140HMMCB - 624	017110

Ratings & Dimensions Close-Coupled - Taper-Lock® Bushed

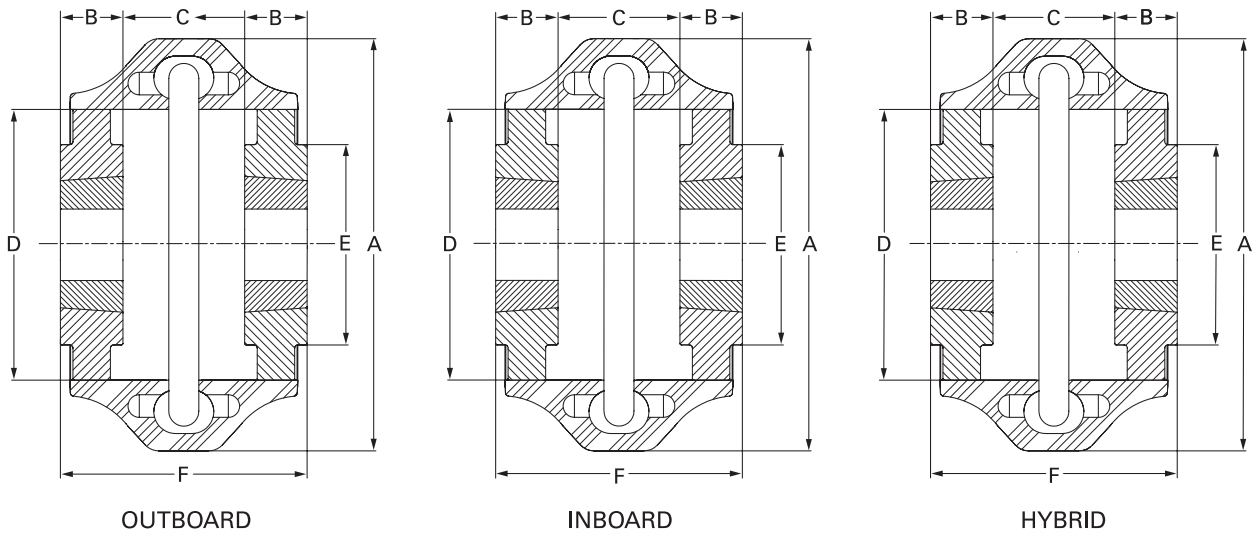

Coupling Size	Bushing Size	Max. Bore ⁽¹⁾	HP/100	Max Torque (In-Lbs.)	Max. RPM	A	B	C			D	E	F			Weight ⁽⁴⁾ (Lbs.)
								Outboard	Inboard	Hybrid			Outboard	Inboard	Hybrid	
E3	1008	1.00	0.59	371	7,500	4.00	0.88	1.68	1.68	1.68	2.32	2.00	3.44	3.44	3.44	2.2
E4	1008	1.00	0.89	558	7,500	4.56	0.88	1.68	1.68	1.68	2.60	2.25	3.44	3.44	3.44	2.9
E5	1108	1.13	1.47	926	7,500	5.38	0.88	2.17	2.19	2.19	3.13	2.80	3.93	3.95	3.95	4.8
E10	1310	1.44	2.31	1,456	7,500	6.38	1.00	2.06	2.06	2.06	3.65	3.30	4.06	4.06	4.06	6.4
E20	1610	1.69	3.66	2,308	6,600	7.25	1.00	2.50	2.50	2.50	4.48	3.50	4.50	4.50	4.50	9.2
E30	2012	2.13	5.79	3,651	5,800	8.25	1.25	2.56	2.56	2.56	5.42	4.01	5.06	5.06	5.06	14.8
E40	2517	2.69	8.73	5,504	5,000	9.50	1.75	2.38	2.38	2.38	6.63	4.63	5.88	5.88	5.88	23.8
E50	2517	2.69	12.1	7,656	4,200	11.00	1.75	3.00	3.00	3.00	8.13	4.93	6.50	6.50	6.50	35.2
E60	3020	3.25	19.8	12,505	3,800	12.50	2.00	3.31	3.31	3.31	8.75	5.75	7.31	7.31	7.31	53.6
E70	3535	3.94	35.1	22,132	3,600	14.00	3.50	2.38	2.38	2.38	9.25	6.50	9.38	9.38	9.38	77.7
E80	4040	4.44	62.7	39,503	2,000	16.00	4.00	3.75	3.75	3.75	11.25	7.75	11.75	11.75	11.75	129.0
E100	4535	4.94	135.0	85,085	1,900	21.00	3.50	3.52	6.02	4.77	14.13	10.51	10.52	13.02	11.77	254.0
E120	5040	5.00	199.9	126,000 ⁽²⁾	1,800	25.00	4.00	4.26	6.90	5.58	17.63	11.76	12.26	14.90	13.58	428.0
E140	7060	7.00	540.0	340,340	1,500	30.00	6.00	3.02	7.02	5.02	20.88	15.01	15.02	19.02	17.02	713.0

- (1) All maximum bore dimensions are based off of shallow keys
- (2) Maximum torque is limited by maximum bushing rated torque
- (3) Space required to install bushing with shortened hex key
- (4) Space required to remove bushing with shortened hex key
- (5) Weight of complete coupling including the bushing at maximum bore
- (6) All dimensions in inches

Taper-Lock Bushed Part Numbers

Coupling Size	TL Hub	Bushing Size	Standard (Natural Rubber) Element	Armored Elements	Replacement Hardware
3HTL	015801	1008	015844	017127	017001
4HTL	015802	1008	015845	017128	
5HTL	015803	1108	015846	017129	
10HTL	015804	1310	015847	017130	017180
20HTL	015805	1610	015848	017131	017002
30HTL	015806	2012	015849	017132	
40HTL	015807	2517	015850	017133	
50HTL	015808	2517	015851	017134	017003
60HTL	015809	3020	015852	017135	017004
70HTL	015810	3535	015853	017136	
80HTL	015865	4040	015854	017137	
100HTL	015201	4535	015931	017138	017005
120HTL	015202	5040	015932	017139	017006
140HTL	015203	7060	015933	017140	017007

- (1) Element assemblies include hardware.
- (2) Raptor elements are also available with metric hardware. This requires use of shaft hubs tapped for metric hardware. Reference International Couplings Catalog (ICA4004) or contact Baldor for more information.

Ratings & Dimensions Spacer - Taper-Lock® Bushed

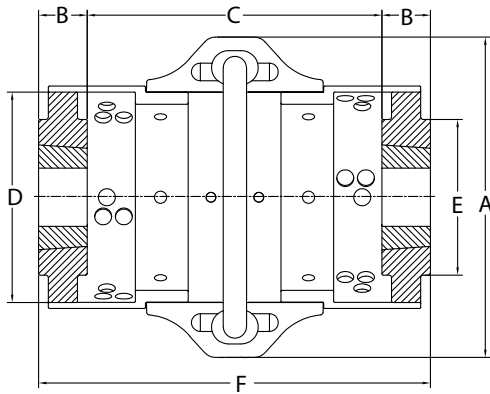

FULL SPACER

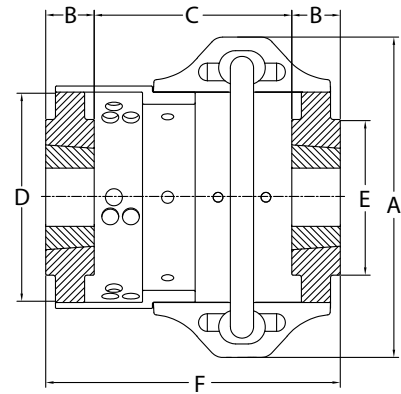

HALF SPACER

Coupling Size	Bushing Size	Max. Bore ⁽¹⁾	HP/100	Max Torque (In-Lbs.)	Max. RPM	A	B	C		D	E	F		Weight ⁽²⁾ (Lbs.)
								Min.	Max			Min.	Max.	
ES3	1008	1.00	0.59	371	7,500	4.00	0.88	2.51	6.38	2.32	2.00	4.67	8.14	3.6
ES4	1008	1.00	0.89	558	7,500	4.56	0.88	2.33	6.75	2.60	2.36	4.29	8.50	4.7
ES5	1108	1.13	1.47	926	7,500	5.38	0.88	2.52	6.89	3.13	2.80	4.44	8.65	7.2
ES10	1310	1.44	2.31	1,456	7,500	6.38	1.00	2.26	7.01	3.65	3.30	4.27	9.02	9.2
ES20	1610	1.69	3.66	2,308	6,600	7.25	1.00	2.82	9.29	4.48	4.00	4.90	11.29	13.8
ES30	2012	2.13	5.79	3,651	5,800	8.25	1.25	2.57	9.46	5.42	4.62	5.12	11.95	21.9
ES40	2517	2.69	8.73	5,504	5,000	9.50	1.75	2.44	9.37	6.63	5.75	5.94	12.87	33.9
ES50	2517	2.69	12.1	7,656	4,200	11.00	1.75	2.89	11.09	8.13	6.13	6.39	14.59	48.3
ES60	3020	3.25	19.8	12,505	3,800	12.50	2.00	3.30	13.22	8.75	6.50	7.30	17.22	77.1
ES70	3535	3.94	35.1	22,132	3,600	14.00	3.50	2.39	12.43	9.25	6.99	9.38	19.42	102.0
ES80	4040	4.44	62.7	39,503	2,000	16.00	4.00	3.87	18.80	11.25	9.49	11.94	26.79	166.8

- (1) Maximum bores may require use of shallow key and/or steel bushings. Consult the Baldor•Dodge PTC Engineering catalog for bushing requirements.
- (2) Weight of complete coupling at maximum bore with four spacer extensions and bushings at maximum bore
- (3) All dimensions in inches

Taper-Lock Bushed Spacer Length Options

Size	Standard (Natural Rubber) Element Part Number		Armored Elements		ANSI (in.)				ISO & DIN (mm)			
	Full Spacer	Half Spacer	Full Spacer	Half Spacer	3.5	5	7	10	100	140	180	250
ES3	017065	017183	017157	017219	3.3	4.8			96	136		
ES4	017066	017184	017158	017220	3.3	4.8			96	136		
ES5	017067	017185	017159	017221	3.3	4.8			96	136		
ES10	017068	017186	017160	017222	3.3	4.8			96	136		
ES20	017069	017187	017161	017223	3.5	5.0	7.0		99	139	179	
ES30	017070	017188	017162	017224	3.5	5.0	7.0		100	140	180	
ES40	017071	017189	017163	017225		5.2	7.2		106	146	186	
ES50	017072	017190	017164	017226		5.2	7.2		106	146	186	
ES60	017073	017191	017165	017227		5.2	7.2	10.2		144	184	254
ES70	017074	017192	017166	017228			7.8	10.8			201	271
ES80	017075	017193	017167	017229			8.1	11.1			207	277

- (1) Element assemblies include hardware.
- (2) Table shows actual spacer lengths relative to standard ANSI and ISO spacer lengths

Full Spacers
 Half Spacers

Ratings & Dimensions Close-Coupled - QD Bushed

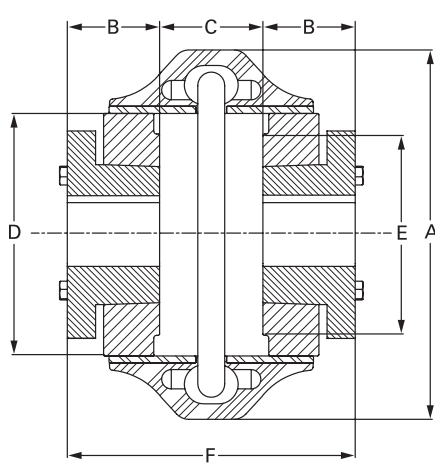

OUTBOARD

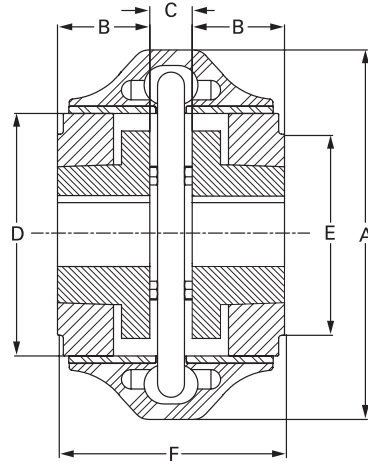

INBOARD

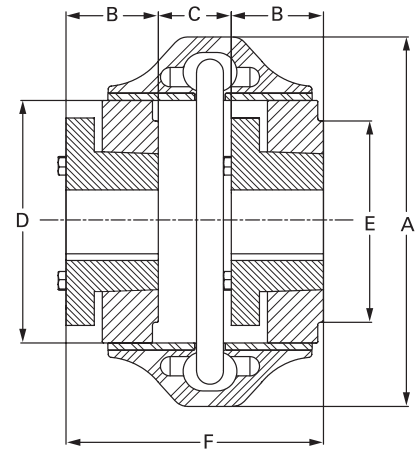

HYBRID

Coupling Size	Bushing Size	Max. Bore ⁽¹⁾	HP/100	Max Torque (In-Lbs.)	Max. RPM	A	B	C			D	E	F			Weight ⁽³⁾ (Lbs.)
								Outboard	Inboard	Hybrid			Outboard	Inboard	Hybrid	
E4	JA	1.19	0.89	558	7,500	4.56	1.00	1.90	1.24	1.57	2.60	2.25	3.90	3.24	3.57	2.9
E5	SH	1.63	1.47	926	7,500	5.38	1.25	1.88	1.62	1.75	3.13	2.80	4.38	4.12	4.25	4.9
E10	SDS	1.94	2.31	1,456	7,500	6.38	1.31	2.32	1.20	1.76	3.65	3.30	4.94	3.82	4.38	6.3
E20	SK	2.50	3.66	2,308	6,600	7.25	1.88	2.62	0.44	1.53	4.48	3.81	6.38	4.20	5.29	11.1
E30	SF	2.94	5.79	3,651	5,800	8.25	2.00	2.43	1.25	1.84	5.42	4.50	6.43	5.25	5.84	17.6
E40	E	3.50	8.73	5,504	5,000	9.50	2.63	2.00	1.00	1.50	6.63	5.75	7.26	6.26	6.76	33.1
E50	E	3.50	12.1	7,656	4,200	11.00	2.63	3.13	1.11	2.12	8.13	5.75	8.39	6.37	7.38	44.9
E60	F	3.94	19.8	12,505	3,800	12.50	3.63	2.13	1.19	1.66	8.75	6.50	9.39	8.45	8.92	68.4
E70	J	4.50	35.1	22,132	3,600	14.00	4.50	1.70	0.92	1.31	9.25	7.25	10.70	9.92	10.31	90.7
E80	M	5.50	62.7	39,503	2,000	16.00	6.75	1.49	0.31	0.90	11.25	9.49	14.99	13.81	14.40	203.0
E100	M	5.50	134.9	85,000	1,900	21.00	6.75	1.77	1.07	1.42	14.13	10.51	15.27	14.57	14.92	297.0
E120	N	6.00	238.0	150,000 ⁽²⁾	1,800	25.00	8.12	2.27	0.77	1.52	17.63	11.51	18.51	17.01	17.76	496.0
E140	P	7.00	396.7	250,000 ⁽²⁾	1,500	30.00	9.38	3.52	-	1.64	20.88	15.01	22.28	-	20.40	835.0

- (1) All maximum bore dimensions are based off of shallow keys
- (2) Maximum torque is limited by maximum bushing rated torque
- (3) Space required to install bushing with open end wrench
- (4) Space required to remove bushing with open end wrench
- (5) Weight of complete coupling including the bushing at maximum bore
- (6) All dimensions in inches

QD Bushed Part Numbers

Coupling Size	QD Hub	Bushing Size	Standard (Natural Rubber) Elements	Armored Elements	Replacement Hardware
4HQD	015811	JA	015845	017128	017001
5HQD	015812	SH	015846	017129	
10HQD	015813	SDS	015847	017130	
20HQD	015814	SK	015848	017131	017180
30HQD	015815	SF	015849	017132	
40HQD	015816	E	015850	017133	017002
50HQD	015817	E	015851	017134	
60HQD	015818	F	015852	017135	
70HQD	015819	J	015853	017136	017003
80HQD	015866	M	015854	017137	
100HQD	015204	M	015931	017138	017004
120HQD	015205	N	015932	017139	
140HQD	015206	P	015933	017140	017005
					017006
					017007

Element assemblies include hardware.

Ratings & Dimensions Spacer - QD Bushed

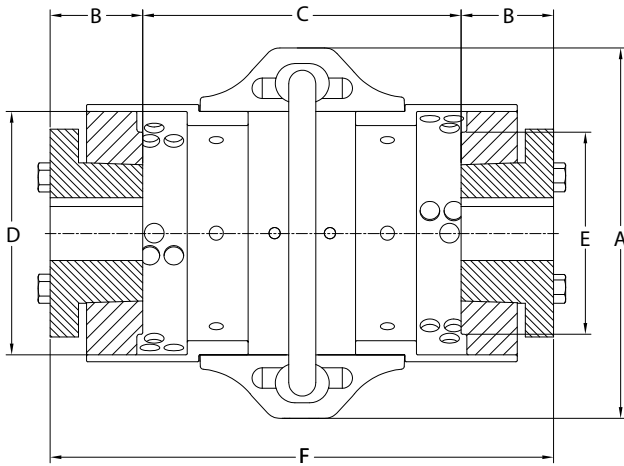

OUTBOARD FULL SPACER

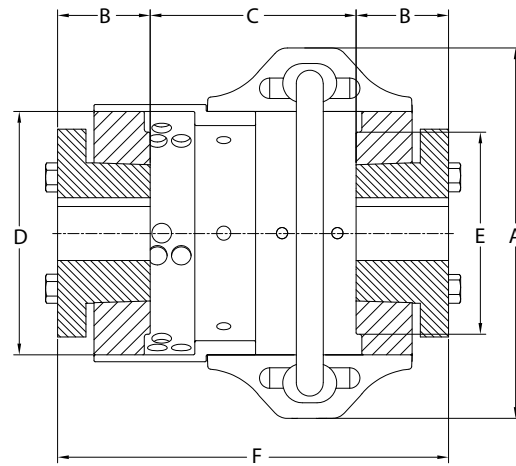

OUTBOARD HALF SPACER

Coupling Size	Bushing Size	Max. Bore ⁽¹⁾	HP/100	Max Rated Torque (In-Lbs.)	Max. RPM	A	B	C		D	E	F		Weight ⁽²⁾ (Lbs.)
								Min.	Max			Min.	Max.	
ES4	JA	1.19	0.89	558	7,500	4.56	1.00	2.53	6.29	2.60	2.36	4.73	8.28	4.7
ES5	SH	1.63	1.47	926	7,500	5.38	1.25	2.21	6.45	3.13	2.80	4.87	8.95	7.2
ES10	SDS	1.94	2.31	1,456	7,500	6.38	1.31	2.51	6.14	3.65	3.30	5.14	8.77	9.0
ES20	SK	2.50	3.66	2,308	6,600	7.25	1.88	2.94	7.41	4.48	4.00	6.78	11.17	15.7
ES30	SF	2.94	5.79	3,651	5,800	8.25	2.00	2.20	8.34	5.42	4.62	6.25	12.33	24.8
ES40	E	3.50	8.73	5,504	5,000	9.50	2.63	1.81	8.24	6.63	5.75	7.07	13.50	43.1
ES50	E	3.50	12.1	7,656	4,200	11.00	2.63	2.77	9.46	8.13	6.13	8.03	14.72	58.0
ES60	F	3.94	19.8	12,505	3,800	12.50	3.63	1.88	11.41	8.75	6.50	9.14	18.67	91.9
ES70	J	4.50	35.1	22,132	3,600	14.00	4.50	1.44	11.36	9.25	6.99	10.43	20.35	115.0
ES80	M	5.50	62.7	39,503	2,000	16.00	6.75	1.37	15.80	11.25	9.49	14.94	29.29	240.9

(1) Maximum bores may require use of shallow key. Consult the Baldor•Dodge PTC Engineering catalog for bushing requirements.

(2) Weight of complete coupling at maximum bore with four spacer extensions

(3) All dimensions in inches

QD Bushed Spacer Length Options

Size	Standard (Natural Rubber) Element Part Number		Armored Elements		ANSI (in.)				ISO & DIN (mm)			
	Full Spacer	Half Spacer	Full Spacer	Half Spacer	3.5	5	7	10	100	140	180	250
ES4	017066	017184	017158	017220	3.2	4.7			93	133		
ES5	017067	017185	017159	017221	3.5	5.0			99	139		
ES10	017068	017186	017160	017222	3.3	4.8			94	134		
ES20	017069	017187	017161	017223	3.4	4.9	6.9		98	138	178	
ES30	017070	017188	017162	017224	3.6	5.1	7.1		102	142	182	
ES40	017071	017189	017163	017225		5.4	7.4		111	151	191	
ES50	017072	017190	017164	017226		5.2	7.2		104	144	184	
ES60	017073	017191	017165	017227		5.8	7.8	10.8		159	199	269
ES70	017074	017192	017166	017228			8.2	11.2			209	279
ES80	017075	017193	017167	017229			9.2	12.2			236	306

(1) Element assemblies include hardware.

(2) Table shows actual spacer lengths relative to standard ANSI and ISO spacer lengths

(3) All calculations based off of outboard hubs.

Full Spacers
Half Spacers

Spacer Element Component Details

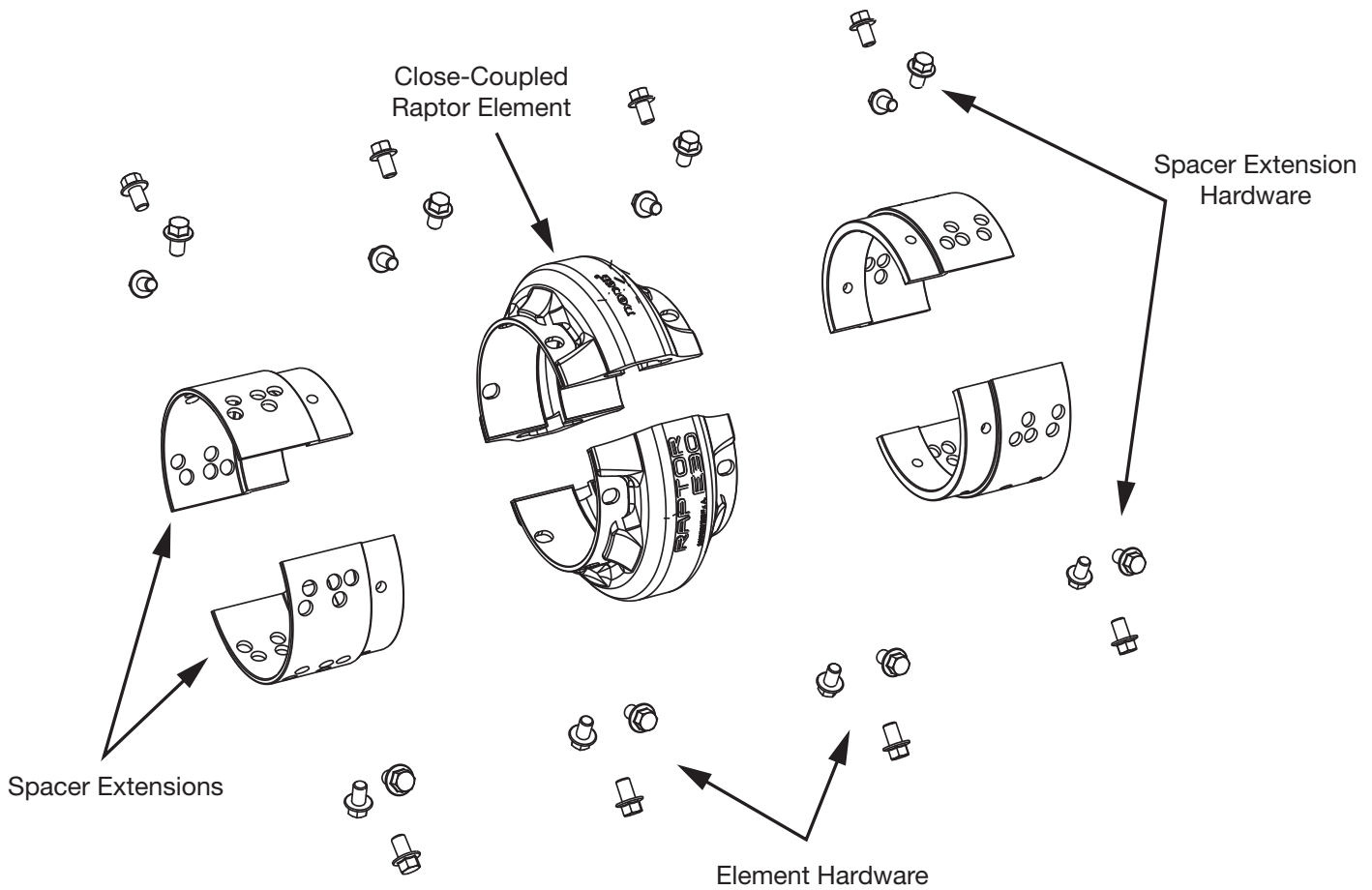

Raptor Spacer Element Component Part Numbers

Coupling Size	Complete Spacer Element Assemblies		Replacement Components			
	Standard (Natural Rubber) Elements		Close-Coupled Elements ^{(1) (2)}		Spacer Extension Kit ^{(3) (4)}	Replacement Hardware
	Full Spacer	Half Spacer	Standard (Natural Rubber)	Armored Elements		
ES2	017064	017182	015843	017126	017040	017000
ES3	017065	017183	015844	017127	017041	017001
ES4	017066	017184	015845	017128	017042	
ES5	017067	017185	015846	017129	017043	
ES10	017068	017186	015847	017130	017044	017180
ES20	017069	017187	015848	017131	017045	017002
ES30	017070	017188	015849	017132	017046	
ES40	017071	017189	015850	017133	017047	017003
ES50	017072	017190	015851	017134	017048	
ES60	017073	017191	015852	017135	017049	
ES70	017074	017192	015853	017136	017050	017004
ES80	017075	017193	015854	017137	017051	

(1) For replacement on existing Raptor half or full spacer couplings, purchase only close-coupled element if spacer extensions remain on shaft hubs

(2) For replacement on existing Raptor half or full spacer couplings, purchase close-coupled element and one set of replacement hardware if spacer extensions have been removed from shaft hubs

(3) To convert an existing close-coupled Raptor element into a half spacer element, purchase one spacer extension kit

(4) To convert an existing close-coupled Raptor element into a full spacer element, purchase two spacer extension kits

ISO R775 Metric Bore and Keyway Fits

Nominal Shaft Diameter (mm)	Shaft Diameter		Clearance Fit				Transitional Fit				Interference Fit				Keyway						
	Max.	Min.	Hub Bore		Fit		Hub Bore		Fit		Hub Bore		Fit		Nominal		Width. D10		Scribe Height		
			F7		H7		M6								Width	X	Height	Min	Max	Min	Max
	+0.008	-0.003	+0.016	+0.034	+0.008	+0.037	0.000	+0.018	-0.008	+0.021	-0.015	-0.004	-0.023	-0.001							
12	12.008	/ 11.997	12.016	/ 12.034	0.008	/ 0.037	12.000	/ 12.018	-0.008	/ 0.021	11.985	/ 11.996	-0.023	/ -0.001	4	X	1.8	4.03	4.078	13.8	13.9
14	14.008	/ 13.997	14.016	/ 14.034	1.008	/ 1.037	14.000	/ 14.018	-0.008	/ 0.021	13.985	/ 13.996	-0.023	/ -0.001	5	X	2.3	5.03	5.078	16.3	16.4
16	16.008	/ 15.997	16.016	/ 16.034	2.008	/ 2.037	16.000	/ 16.018	-0.008	/ 0.021	15.985	/ 15.996	-0.023	/ -0.001	5	X	2.3	5.03	5.078	18.3	18.4
18	18.008	/ 17.997	18.016	/ 18.034	3.008	/ 3.037	18.000	/ 18.018	-0.008	/ 0.021	17.985	/ 17.996	-0.023	/ -0.001	6	X	2.8	6.03	6.078	20.8	20.9
>18	j6	-0.004	+0.02	+0.041	+0.011	+0.045	0.000	+0.021	-0.009	+0.025	-0.017	-0.004	-0.026	0.000							
19	19.009	/ 18.996	19.02	/ 19.041	0.011	/ 0.045	19.000	/ 19.021	-0.009	/ 0.025	18.983	/ 18.996	-0.026	/ 0.000	6	X	2.8	6.03	6.078	21.8	21.9
20	20.009	/ 19.996	20.02	/ 20.041	0.011	/ 0.045	20.000	/ 20.021	-0.009	/ 0.025	19.983	/ 19.996	-0.026	/ 0.000	6	X	2.8	6.03	6.078	22.8	22.9
22	22.009	/ 21.996	22.02	/ 22.041	0.011	/ 0.045	22.000	/ 22.021	-0.009	/ 0.025	21.983	/ 21.996	-0.026	/ 0.000	6	X	2.8	6.03	6.078	24.8	24.9
24	24.009	/ 23.996	24.02	/ 24.041	0.011	/ 0.045	24.000	/ 24.021	-0.009	/ 0.025	23.983	/ 23.996	-0.026	/ 0.000	8	X	3.3	8.04	8.098	27.3	27.5
25	25.009	/ 24.996	25.02	/ 25.041	0.011	/ 0.045	25.000	/ 25.021	-0.009	/ 0.025	24.983	/ 24.996	-0.026	/ 0.000	8	X	3.3	8.04	8.098	28.3	28.5
28	28.009	/ 27.996	28.02	/ 28.041	0.011	/ 0.045	28.000	/ 28.021	-0.009	/ 0.025	27.983	/ 27.996	-0.026	/ 0.000	8	X	3.3	8.04	8.098	31.3	31.5
30	30.009	/ 29.996	30.02	/ 30.041	0.011	/ 0.045	30.000	/ 30.021	-0.009	/ 0.025	29.983	/ 29.996	-0.026	/ 0.000	8	X	3.3	8.04	8.098	33.3	33.5
>30	k6	+0.018	+0.002	+0.025	+0.050	+0.007	+0.048	0.000	+0.025	-0.018	+0.023	-0.013	+0.003	-0.031	+0.001						
32	32.018	/ 32.002	32.025	/ 32.050	0.007	/ 0.048	32.000	/ 32.025	-0.018	/ 0.023	31.987	/ 32.003	-0.031	/ 0.001	10	X	3.3	10.04	10.098	35.3	35.5
35	35.018	/ 35.002	35.025	/ 35.050	0.007	/ 0.048	35.000	/ 35.025	-0.018	/ 0.023	34.987	/ 35.003	-0.031	/ 0.001	10	X	3.3	10.04	10.098	38.3	38.5
38	38.018	/ 38.002	38.025	/ 38.050	0.007	/ 0.048	38.000	/ 38.025	-0.018	/ 0.023	37.987	/ 38.003	-0.031	/ 0.001	10	X	3.3	10.04	10.098	41.3	41.5
40	40.018	/ 40.002	40.025	/ 40.050	0.007	/ 0.048	40.000	/ 40.025	-0.018	/ 0.023	39.987	/ 40.003	-0.031	/ 0.001	12	X	3.3	12.05	12.12	43.3	43.5
42	42.018	/ 42.002	42.025	/ 42.050	0.007	/ 0.048	42.000	/ 42.025	-0.018	/ 0.023	41.987	/ 42.003	-0.031	/ 0.001	12	X	3.3	12.05	12.12	45.3	45.5
45	45.018	/ 45.002	45.025	/ 45.050	0.007	/ 0.048	45.000	/ 45.025	-0.018	/ 0.023	44.987	/ 45.003	-0.031	/ 0.001	14	X	3.8	14.05	14.12	48.8	49
48	48.018	/ 48.002	48.025	/ 48.050	0.007	/ 0.048	48.000	/ 48.025	-0.018	/ 0.023	47.987	/ 48.003	-0.031	/ 0.001	14	X	3.8	14.05	14.12	51.8	52
50	50.018	/ 50.002	50.025	/ 50.050	0.007	/ 0.048	50.000	/ 50.025	-0.018	/ 0.023	49.987	/ 50.003	-0.031	/ 0.001	14	X	3.8	14.05	14.12	53.8	54
>50	m6	+0.030	+0.011	+0.030	+0.060	0	+0.049	0.000	+0.030	-0.030	+0.019	-0.021	+0.009	-0.051	-0.002						
55	55.030	/ 55.011	55.030	/ 55.060	0.000	/ 0.049	55.000	/ 55.030	-0.030	/ 0.019	54.979	/ 55.009	-0.051	/ -0.002	16	X	4.3	16.05	16.12	59.3	59.5
56	56.030	/ 56.011	56.030	/ 56.060	0.000	/ 0.049	56.000	/ 56.030	-0.030	/ 0.019	55.979	/ 56.009	-0.051	/ -0.002	16	X	4.3	16.05	16.12	60.3	60.5
60	60.030	/ 60.011	60.030	/ 60.060	0.000	/ 0.049	60.000	/ 60.030	-0.030	/ 0.019	59.979	/ 60.009	-0.051	/ -0.002	18	X	4.4	18.05	18.12	64.4	64.6
63	63.030	/ 63.011	63.030	/ 63.060	0.000	/ 0.049	63.000	/ 63.030	-0.030	/ 0.019	62.979	/ 63.009	-0.051	/ -0.002	18	X	4.4	18.05	18.12	67.4	67.6
65	65.030	/ 65.011	65.030	/ 65.060	0.000	/ 0.049	65.000	/ 65.030	-0.030	/ 0.019	64.979	/ 65.009	-0.051	/ -0.002	18	X	4.4	18.05	18.12	69.4	69.6
70	70.030	/ 70.011	70.030	/ 70.060	0.000	/ 0.049	70.000	/ 70.030	-0.030	/ 0.019	69.979	/ 70.009	-0.051	/ -0.002	20	X	4.9	20.065	20.149	74.9	75.1
71	71.030	/ 71.011	71.030	/ 71.060	0.000	/ 0.049	71.000	/ 71.030	-0.030	/ 0.019	70.979	/ 71.009	-0.051	/ -0.002	20	X	4.9	20.065	20.149	75.9	76.1
75	75.030	/ 75.011	75.030	/ 75.060	0.000	/ 0.049	75.000	/ 75.030	-0.030	/ 0.019	74.979	/ 75.009	-0.051	/ -0.002	20	X	4.9	20.065	20.149	79.9	80.1
80	80.030	/ 80.011	80.030	/ 80.060	0.000	/ 0.049	80.000	/ 80.030	-0.030	/ 0.019	79.979	/ 80.009	-0.051	/ -0.002	22	X	5.4	22.065	22.149	85.4	85.6
>80	m6	+0.035	+0.013	+0.036	+0.071	+0.001	+0.058	0.000	+0.035	-0.035	+0.022	-0.035	0.000	-0.070	-0.013						
85	85.035	/ 85.013	85.036	/ 85.071	0.001	/ 0.058	85.000	/ 85.035	-0.035	/ 0.022	84.965	/ 85.000	-0.070	/ -0.013	22	X	5.4	22.065	22.149	90.4	90.6
90	90.035	/ 90.013	90.036	/ 90.071	0.001	/ 0.058	90.000	/ 90.035	-0.035	/ 0.022	89.965	/ 90.000	-0.070	/ -0.013	25	X	5.4	25.065	25.149	95.4	95.6
95	95.035	/ 95.013	95.036	/ 95.071	0.001	/ 0.058	95.000	/ 95.035	-0.035	/ 0.022	94.965	/ 95.000	-0.070	/ -0.013	25	X	5.4	25.065	25.149	100.4	100.6
100	100.035	/ 100.013	100.036	/ 100.071	0.001	/ 0.058	100.000	/ 100.035	-0.035	/ 0.022	99.965	/ 100.000	-0.070	/ -0.013	28	X	6.4	28.065	28.149	106.4	106.6
>100	m6	+0.035	+0.013	+0.036	+0.071	+0.001	+0.058	0.000	+0.035	-0.035	+0.022	-0.059	-0.024	-0.094	-0.037						
110	110.035	/ 110.013	110.036	/ 110.071	0.001	/ 0.058	110.000	/ 110.035	-0.035	/ 0.022	109.941	/ 109.976	-0.094	/ -0.037	28	X	6.4	28.065	28.149	116.4	116.6
120	120.035	/ 120.013	120.036	/ 120.071	0.001	/ 0.058	120.000	/ 120.035	-0.035	/ 0.022	119.941	/ 119.976	-0.094	/ -0.037	32	X	7.4	32.08	32.18	127.4	127.6
>120	m6	+0.040	+0.015	+0.043	+0.083	+0.003	+0.068	0.000	+0.040	-0.040	+0.025	-0.068	-0.028	-0.108	-0.043						
125	125.040	/ 125.015	125.043	/ 125.083	0.003	/ 0.068	125.000	/ 125.040	-0.040	/ 0.025	124.932	/ 124.972	-0.108	/ -0.043	32	X	7.4	32.08	32.18	132.4	132.6
130	130.040	/ 130.015	130.043	/ 130.083	0.003	/ 0.068	130.000	/ 130.040	-0.040	/ 0.025	129.932	/ 129.972	-0.108	/ -0.043	32	X	7.4	32.08	32.18	137.4	137.6
140	140.040	/ 140.015	140.043	/ 140.083	0.003	/ 0.068	140.000	/ 140.040	-0.040	/ 0.025	139.932	/ 139.972	-0.108	/ -0.043	36	X	8.4	36.08	36.18	148.4	148.7
150	150.040	/ 150.015	150.043	/ 150.083	0.003	/ 0.068	150.000	/ 150.040	-0.040	/ 0.025	149.932	/ 149.972	-0.108	/ -0.043	36	X	8.4	36.08	36.18	158.4	158.7
160	160.040	/ 160.015	160.043	/ 160.083	0.003	/ 0.068	160.000	/ 160.040	-0.040	/ 0.025	159.932	/ 159.972	-0.108	/ -0.043	40	X	9.4	40.08	40.18	169.4	169.7
170	170.040	/ 170.015	170.043	/ 170.083	0.003	/ 0.068	170.000	/ 170.040	-0.040	/ 0.025	169.932	/ 169.972	-0.108	/ -0.043	40	X	9.4	40.08	40.18	179.4	179.7
180	180.040	/ 180.015																			

Temperature Ratings

Element Type	Minimum	Maximum ⁽¹⁾
Standard Element	-45°F	220°F
Armored Element	-45°F	220°F

(1) Reference high temperature adjustment factors for applications in excess of 180°F

High Temperature Adjustment Factors

Temperature Range	Adjustment
180°F - 200°F	+ 0.75
201°F - 220°F	+ 1.0

NOTE: High temperature adjustment factors are only to be added to the standard system service factors as needed. High temperature service factors are not included in the standard application service factor in order to prevent oversizing coupling selections.

Bore Ranges

Coupling Size	Finished Bore		Taper-Lock			QD		
	Minimum Bore	Max. Bore ⁽¹⁾	Bushing Size	Minimum Bore	Max. Bore ⁽²⁾	Bushing Size	Minimum Bore	Max. Bore ⁽²⁾
2	-	1.188	-	-	-	-	-	-
3	0.375	1.375	1008	0.500	1.000	-	-	-
4	0.375	1.750	1008	0.500	1.000	JA	0.500	1.250
5	0.375	2.250	1108	0.500	1.125	SH	0.500	1.688
10	0.375	2.750	1310	0.500	1.438	SDS	0.500	2.000
20	0.750	3.375	1610	0.500	1.688	SK	0.500	2.625
30	0.750	3.750	2012	0.500	2.125	SF	0.500	2.938
40	0.750	4.875	2517	0.500	2.688	E	0.875	3.500
50	1.125	5.250	2517	0.500	2.688	E	0.875	3.500
60	1.125	5.500	3020	0.875	3.250	F	1.000	4.000
70	1.375	5.875	3535	1.188	3.938	J	1.500	4.500
80	1.875	7.875	4040	1.438	4.438	M	2.000	5.500
100	2.500	8.750	4535	1.938	4.938	M	2.000	5.500
120	2.875	9.750	5040	2.438	5.000	N	2.438	6.000
140	3.250	12.500	7060	4.938	7.000	P	3.438	7.000

(1) Larger bore capacities available. Contact Dodge Engineering for additional details.

(2) With steel Dodge bushings and/or shallow keyway

Torsional Stiffness

Size	Static Torsional Stiffness (in-lbs/degree)
E2	23
E3	32
E4	46
E5	97
E10	114
E20	120
E30	275
E40	440
E50	783
E60	1,379
E70	1,856
E80	2,800
E100	5,900
E120	9,200
E140	14,300

Values are shown for an ambient temperature of 70° F

Values are nominal and may vary by +/- 20%
Torsional stiffness values are for both the standard
Natural Rubber and Armored Element

Elastomer Chemical Compatibility

Substance	Natural Rubber	Armored Element	Substance	Natural Rubber	Armored Element
Acetic Acids	2	3	Hydrobromic Acid (40%)	1	2
Acetic Anhydride	2	3	Kerosene	3	2
Alcohols, Monohydric	2	nd	Lacquers	3	3
Ammonia Anhydrous	3	2	Lead Sulfamate	2	nd
ASTM A Oils	3	1	Mineral Oil	3	1
Animal Fast	3	2	Naphtha	3	2
Benzene	3	3	Nickel Chloride	1	3
Carbonic Acid	3	3	Nitric Acid (10%)	1	3
Calcium Bisulfite	2	nd	Ozone	3	1
Chloracetone	2	3	Petroleum (<250°F)	3	2
Chloroacetic Acid	2	3	Potassium Dichromate	2	1
Copper Sulphate	2	1	Salt Water	1	2
Corn Oil	2	1	Silicone Oils	1	1
Diesel Oil	3	2	Sulfuric Acid (Con.)	3	3
Fuel Oil	3	2	Vinegar	2	3
Gasoline	2	2	Zinc Sulfate	2	2

Ratings:

1 - Minor Effect 2 - Moderate Effect 3 - Severe Effect nd - No Data



P.O. Box 2400, Fort Smith, AR 72902-2400 U.S.A., Ph: (1) 479.646.4711, Fax (1) 479.648.5792, International Fax (1) 479.648.5895

Baldor • Dodge®

6040 Ponders Court, Greenville, SC 29615-4617 U.S.A., Ph: (1) 864.297.4800, Fax: (1) 864.281.2433

www.baldor.com