

Table of Contents

The CB Story	A1
FCC Regulations	
FCC Warnings	
Included Accessories	
Controls & Indicators	A2
Our Thanks to You	A3
Customer Support	
Installation	
Location.....	2
Mounting and Connection.....	2
Antennas	
CB Antenna.....	6
Marine Installation.....	6
Ignition Noise Interference	7
Operating Your 29 LTD Classic	
Turning On Your CB.....	8
Setting Channel Selector.....	9
Calibrate For SWR (Standing Wave Ratio).....	10
To Receive.....	13
Selecting a Channel.....	14
S-Meter.....	14
NB-ANL/ANL/Off (Noise Blanker/Automatic Noise Limiter Switch).....	15
Bright/Dim Switch.....	16
RF Gain Control.....	17
Setting Delta-Tune.....	18
Setting Squelch.....	18
To Transmit.....	20
Setting Dynamike®.....	20
Transmit.....	21
RF Meter.....	22
External Speaker.....	23
PA (Public Address).....	24
Home And Office Set-Up.....	26
Temporary Mobile Set-Up.....	27
How Your CB Can Serve You	28
A Few Rules You Should Know.....	28
Channel 9 Emergency Messages.....	28
CB 10 Codes.....	30
Frequency Ranges	32
29 LTD Classic Specifications	33
FCC Statement	34-35
Warranty Information	36
Product Service	37
Order Info	38

Features of This Product

- 40 CB Radio Channels
- Heavy-Duty Dynamic Microphone
- Full 4 Watts AM RF Power Output
- SWR Calibration
- Instant Channel 9/19
- 4-Pin Front Mount Microphone Connector
- Delta -Tune
- Switchable Automatic Noise Limiter & Noise Blanker
- Adjustable Dynamike® Boost
- 9 Ft. Mic Cord
- RF Gain

Location

Location

Plan location of transceiver and microphone bracket before starting the installation.

Select a location that is convenient for operation, yet does not interfere with the driver or passenger.

The transceiver is usually mounted to the underside of the dash with the microphone bracket beside it.

Mounting and Connection

Note

The transceiver is held in the universal mounting bracket by two thumbscrews which allow for adjustment at a convenient angle.

The bracket includes two self-tapping screws and star washers. The mounting must be mechanically strong, conveniently located.

Mounting and Connection

- 1 Hold the radio with the mounting bracket in the exact desired location. If there is no interference, remove the bracket and use it as a template to mark the location for the mounting screws.

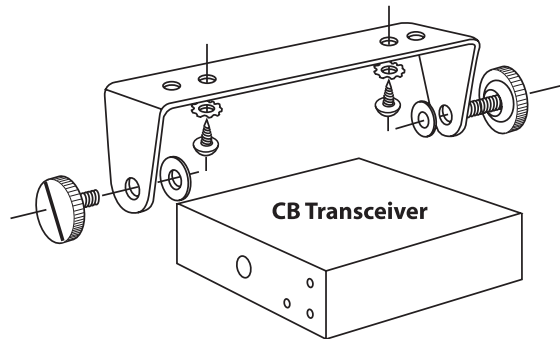

- 2 Drill the holes and secure the bracket.

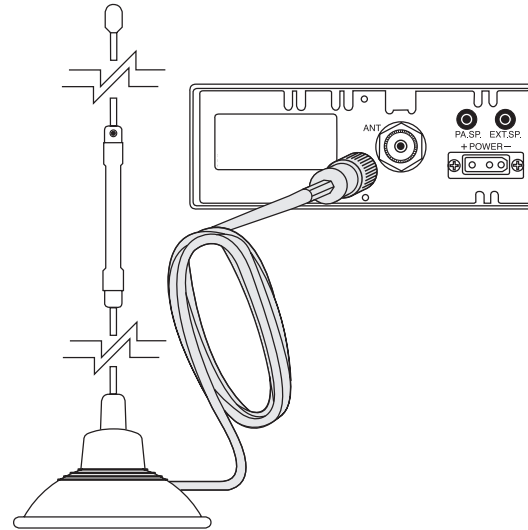

- 3 Connect the antenna cable plug to the receptacle marked "ANT" on the back of the unit.

continued

Installation

Note

For best performance, we recommend the radio be connected directly to the battery.

Note

Before installing the CB radio, visually check the vehicle's battery connection to determine which terminal is positive or negative. A negatively grounded vehicle has its negative lead grounded to the chassis.

Note

Connecting to an accessory fuse prevents the unit from being left on accidentally, and also permits operating the unit without running the engine.

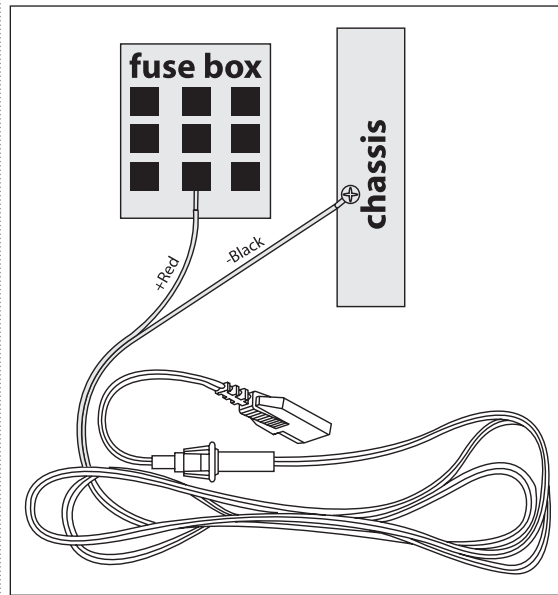

- 4 Connect the red lead of the DC power cord to the positive post of the battery or to an accessory 12 volt fuse.
- 5 Connect the black lead to the negative post of the battery or to the vehicle chassis.

Installation

Note

If the microphone is not connected, audio will not be heard at the speaker.

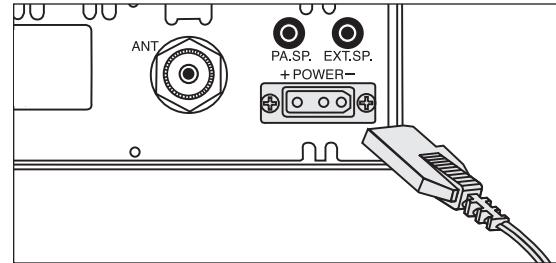

- 6 Plug the power cord into the jack marked "Power" on the back of the unit. Be sure to observe polarity markings.

- 7 Mount the microphone bracket on either side of the radio (driver's left) using the two supplied screws. Bracket should be placed under the dash so the microphone is readily accessible.

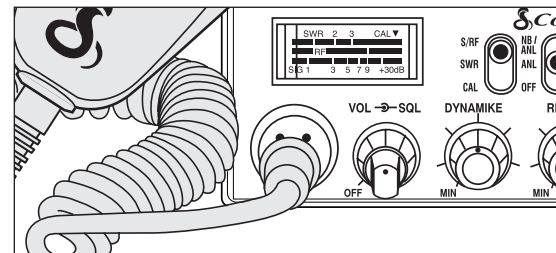
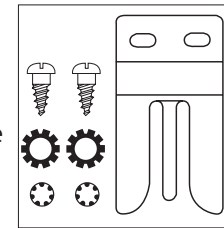

- 8 Attach the 4-pin microphone cable to the connector on the front of the radio and install the microphone on bracket securely.

Antennas

CB Antenna

Note

For optimum performance in passenger cars the ideal antenna location is on the center of the roof. Second choice is on the center of the trunk.

Note

Because many newer trucks feature fiberglass door skins, the outside mirror must be grounded to the chassis via a ground strap when antenna is mounted on the mirror bracket.

Note

3-way Combination Antennas are also available which allow operation of all three bands (AM-FM & CB), using a single antenna. However, this type of antenna usually results in less than normal transmit and receive range when compared to a standard-type "Single Band" CB antenna.

CB Antenna

Since the maximum allowable power output of the transmitter is limited by the FCC, the antenna is critical in affecting transmission distance. Only a properly matched antenna system will allow maximum power output. Cobra loaded type antenna models are highly recommended for most installations. Consult your Cobra dealer for further details, or visit our website: www.cobra.com

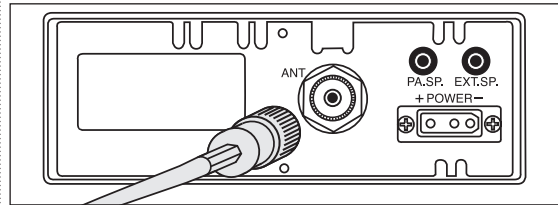

- 1 A standard antenna connector is provided on the transceiver for easy connection.

Marine Installation

The transceiver will not operate at maximum efficiency in a boat without a ground plate, (unless it has a steel hull). Before attempting installation, consult your dealer for information regarding an adequate grounding system and prevention of electrolysis between fittings in the hull and water.

Ignition Noise Interference

Use of a mobile receiver at low signal levels is normally limited by the presence of electrical noise. The primary source of noise in automobiles is from the alternator and ignition system. Typically, when signal level is adequate, the background noise does not present a serious problem. Also, when extremely low level signals are being received, the transceiver may be operated with the vehicle's engine turned off. The unit requires very little current and therefore will not significantly discharge the vehicle's battery.

Even though the Cobra 29 LTD Classic has an automatic noise limiter, in some installations ignition interference may be high enough to make good communications impossible. Many possibilities exist and variations between vehicles require different solutions. Consult your COBRA dealer or a 2-way radio technician for help in locating the source of a severe noise.

Turning On

Turning On

Make sure the power cord, antenna and microphone are connected to their proper connectors before starting.

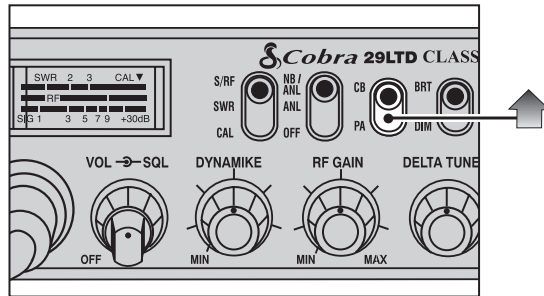

- 1 The CB/PA button should be in the CB position.

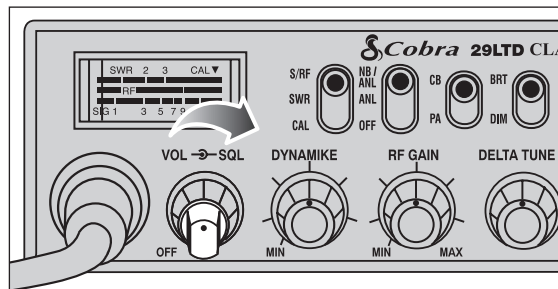



- 2 Rotate the On/Off Volume knob  clockwise to a normal listening level.

Setting Channel Selector

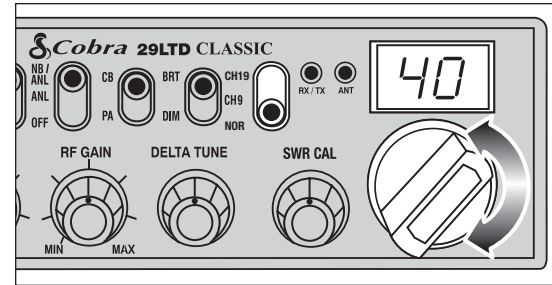
Setting Channel Selector



- 1 Set  the CH9/CH19/NOR switch to NOR.
- 2 Select  one of forty channels and adjust the volume. The selected channel is indicated by the LED readout directly above the channel selector knob.

Calibrate For SWR (Standing Wave Ratio)

Note

Antenna Indicator LED will illuminate RED when transmitting if the SWR is high.

Calibrate for SWR (Standing Wave Ratio)

SWR meter calibration is required to accurately measure the SWR of the connected antenna system. Careful adjustment is critical to obtain best accuracy.

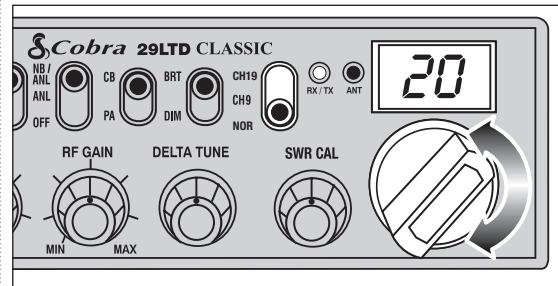

- 1 Select channel 20.

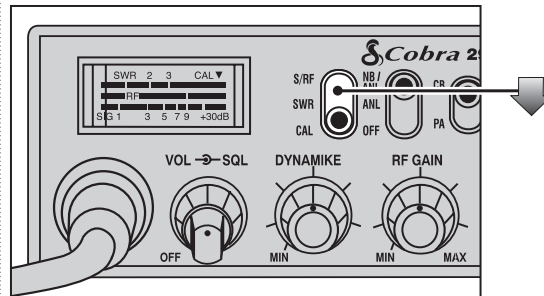

- 2 Switch to the CAL position.

PUSH & HOLD

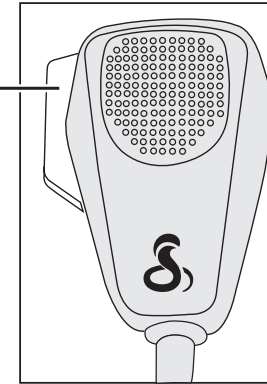

- 3 Push and hold the mic button.

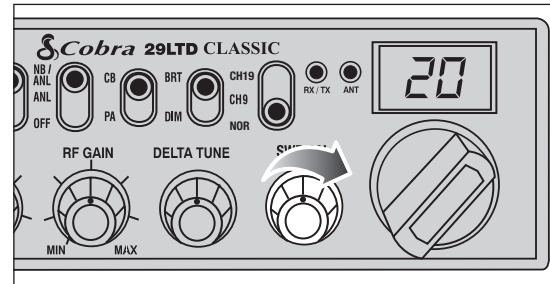

- 4 While holding the mic button *adjust* the SWR CAL knob so the meter needle swings to the CAL ▼ mark on the right side of the meter.

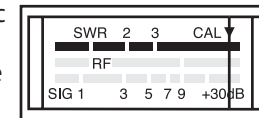

Note

Calibration must be made in an open area (never in a garage). Vehicle doors must be closed. No one should be standing near the antenna. (See your antenna directions for more complete information).

continued

Note

The reading will be slightly higher on Channels 1 and 40 compared to Channel 20.

Note

When switched to SWR position the meter needle should ideally be as far to the left as possible. Anything over 3 is not acceptable. The antenna indicator will light. A slight antenna height adjustment (higher or lower) may be required. Repeat recalibration steps.

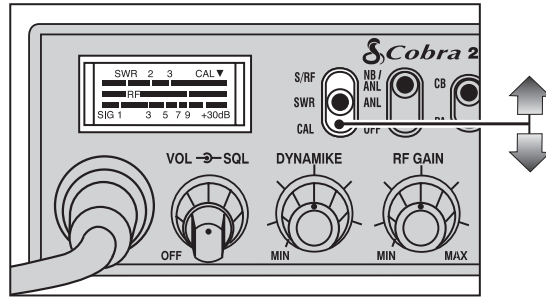

- 5 While still holding down the mic button, set the S/R/F SWR CAL switch to the SWR position, to read the SWR reading.
- 6 Repeat the same steps two through five on Channel 1 and 40. This will check SWR for all channels.

To Receive

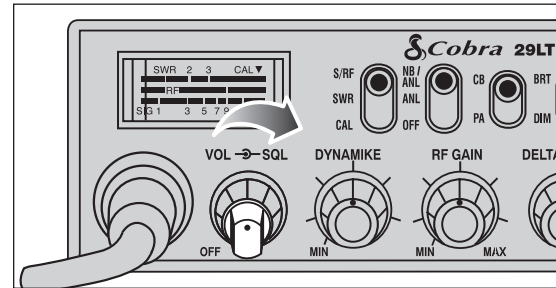

- 1 Rotate the On/Off Volume knob clockwise. The green RX/TX LED will be illuminated.

To Receive

Selecting A Channel

Selecting A Channel

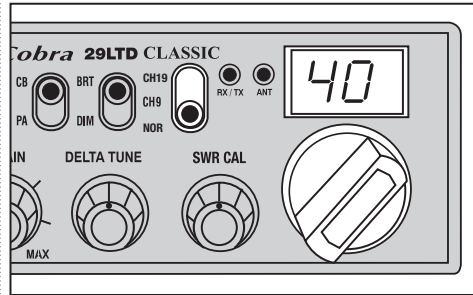

- 1 Switch to NORMAL to select a desired channel.
- 2 Select one of forty channels.

S-Meter

S-Meter

Swings proportionately to the strength of an incoming signal when receiving.

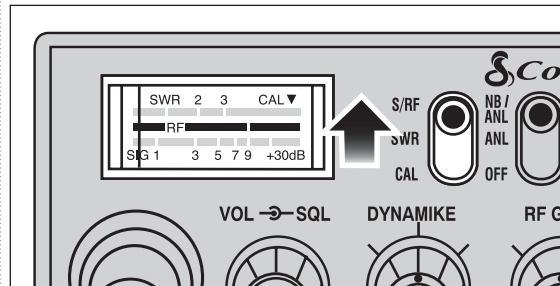

- 1 The S/R/F-SWR-CAL switch must be in the S/R/F position to read the meter.

NB-ANL/ANL/OFF (Noise Blanker/Automatic Noise Limiter) Switch

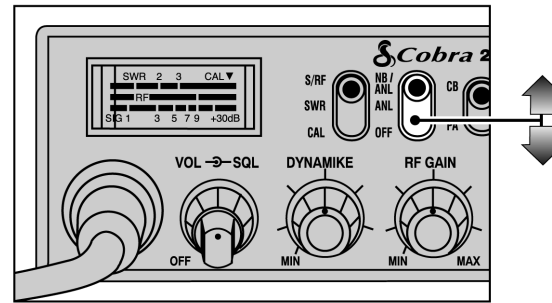

- 1 When switched to ANL the Automatic Noise Limiter is activated. This helps reduce noise created by the vehicle's electronics.

When switched to NB/ANL position the RF Noise Blanker is also activated, providing increased noise filtration.

When switched to OFF position all noise filtration will be turned off.

NB-ANL/ANL/OFF (Noise Blanker/Automatic Noise Limiter) Switch

Note

The RF noise blanker is very effective in reducing repetitive noises such as ignition interference.

Bright/Dim Switch

Bright/Dim Switch

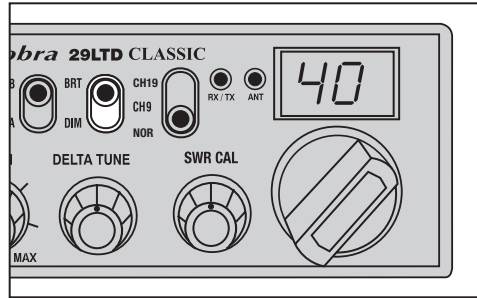



- 1 Switch to  BRT or DIM to control the brightness of the channel indicator and multi-function meter for day or nighttime driving.

RF Gain Control

The RF Gain is used to optimize the reception in strong or weak signal areas.

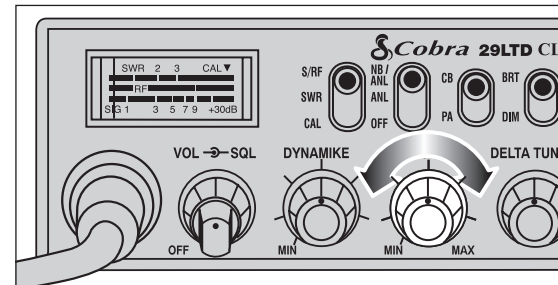
RF Gain Control



- 1 Rotate the  RF Gain knob *counterclockwise* to reduce gain in strong signal areas. In weak signal areas turn *clockwise* to increase the gain.

Operation

Setting Delta-Tune

Setting Delta-Tune

Delta-Tune functions as a “fine tune” control enabling you to capture a more readable signal, as well as eliminate adjacent channel interference.

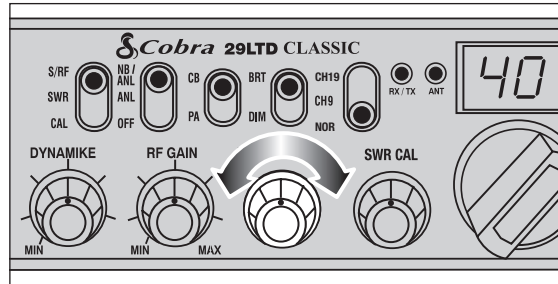

- 1 Rotate Delta-Tune knob to the center position for optimum tuning.

Setting Squelch

Setting Squelch

Squelch is the “control gate” for incoming signals.

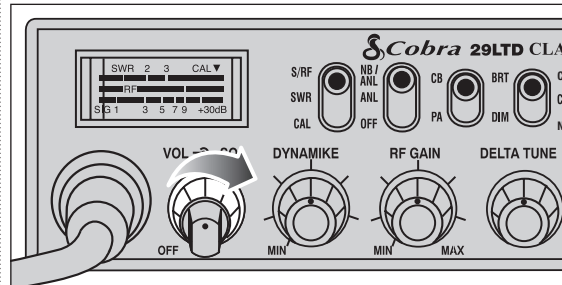

- 1 Full rotation closes the gate allowing only very strong signals to enter.

Gate closed

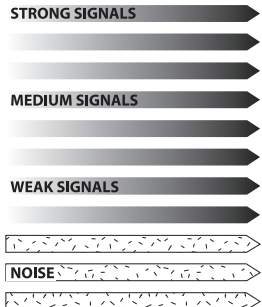

GATE CLOSED

Operation

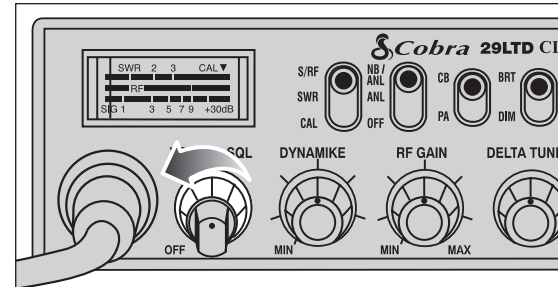

- 2 Full rotation opens the “gate” allowing all signals in.

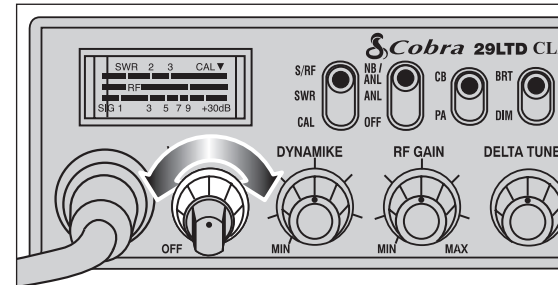

- 3 To achieve the Desired Squelch Setting (DSS), turn the Squelch control until you hear noise. Now turn the control just until the noise stops. This is the DSS setting.

Gate open

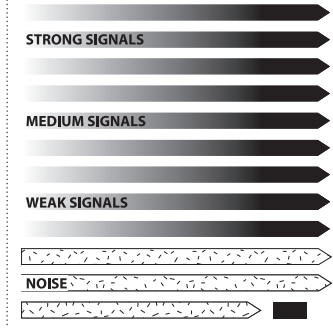

GATE OPEN

Gate set to Desired Squelch Setting (DSS)

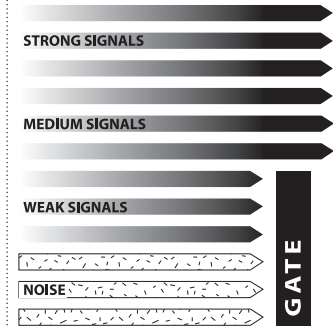

GATE

To Transmit



Caution!

Be sure the antenna is properly connected to the radio before transmitting. Prolonged transmitting without an antenna, or a poorly matched antenna, could cause damage to the transmitter.

Be sure to read the F.C.C. Rules and Regulations before transmitting.

Setting Dynamike®

To Transmit

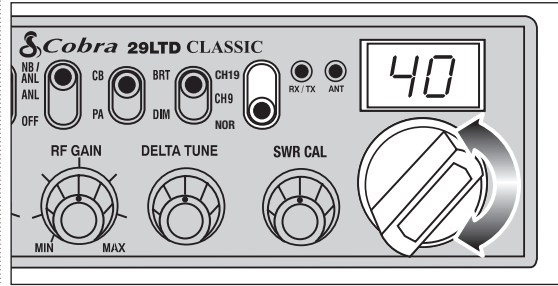

- 1 Select desired channel.

Setting Dynamike®

This controls the microphone sensitivity (outgoing audio level).

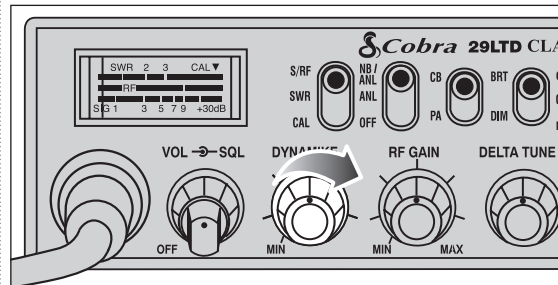

- 1 Initially, set fully clockwise so that maximum voice volume is available. Dynamike® may have to be reduced in some conditions.

Transmit

Transmit

PUSH & HOLD

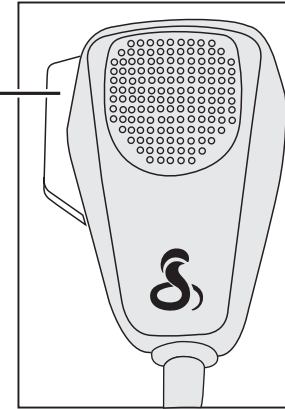



- 1 Push and hold the mic button to transmit. The transmitter is now activated. When transmitting, hold the microphone two inches from your mouth and speak in a clear, normal voice. Release to receive.

RF Meter

RF Meter

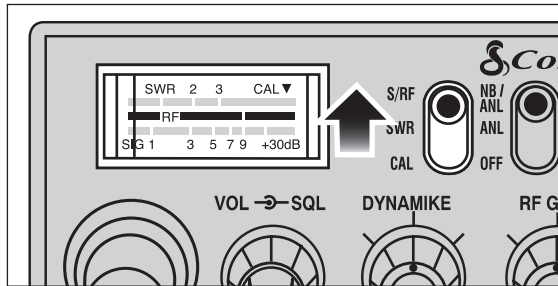
This meter swings proportionately to the RF output (outgoing signal) while transmitting.



The  S/RFSWR-CAL switch must be in the S/RF position.

External Speaker

The external speaker jack is used for remote receiver monitoring.

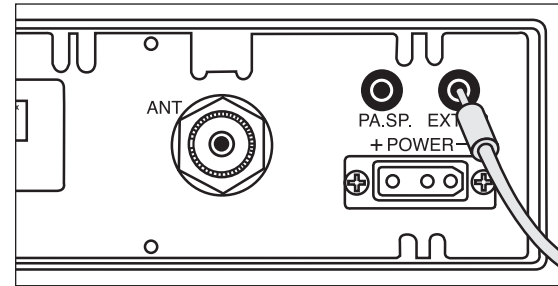

Connect an external speaker to the external speaker jack on the rear panel.

External Speaker

Note

The external speaker should have 8-ohm impedance and be rated to handle at least 4.0 Watts. When the external speaker is plugged in, the internal speaker is automatically disconnected. To order external speakers and other accessories, please go to www.cobra.com

Note

Cobra external speakers are rated at 10 Watts.

PA (Public Address)

Note

The PA speaker should have 8-ohm impedance and be rated to handle at least 4.0 Watts.

Note

The speaker should be directed away from the microphone to prevent acoustic feedback.

Note

Activity on the CB channel will be heard through the PA speaker. Adjust the volume control to a normal listening level.

PA (Public Address)

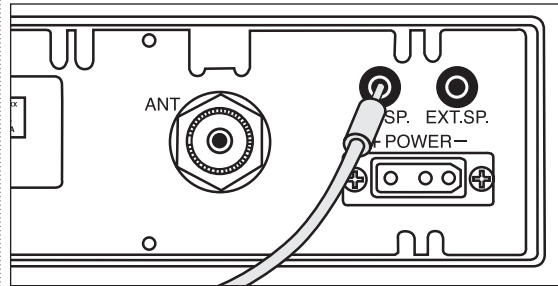

- 1 Connect an external PA speaker to the PA jack on the rear panel.

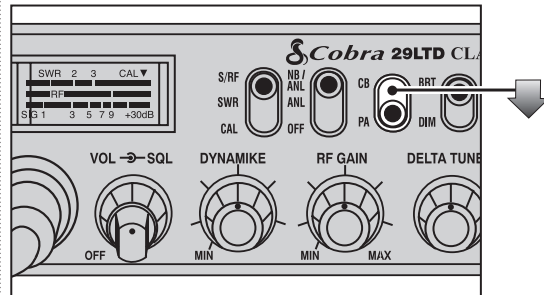

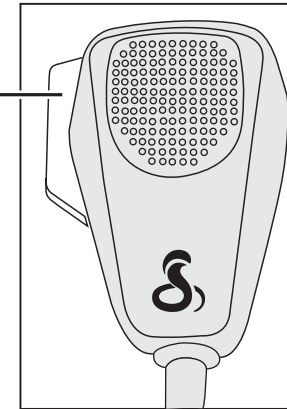

- 2 Set  CB/PA switch to PA position.

PUSH & HOLD

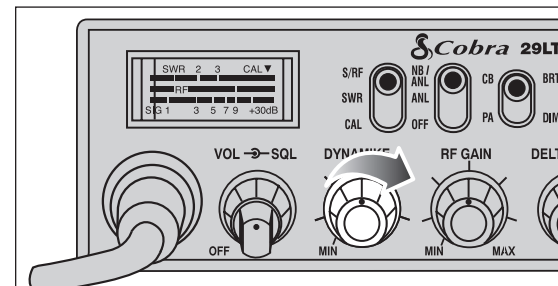

- 3 Push and hold the microphone button and speak in a normal voice. Your voice will be heard on the PA speaker.



- 4 Adjust the PA speaker volume with the  Dynamike® control.

Home And Office Set-Up

Base Station Operation (From 120V AC House Current)

Warning!
Do not attempt to operate this transceiver by connecting it directly to 120V AC.



Base Station Operation (From 120V AC House Current)

To operate the transceiver from your home or office you will need a 13.8 Volt DC Power Supply rated at a minimum of 2 amps and a properly installed base station antenna.

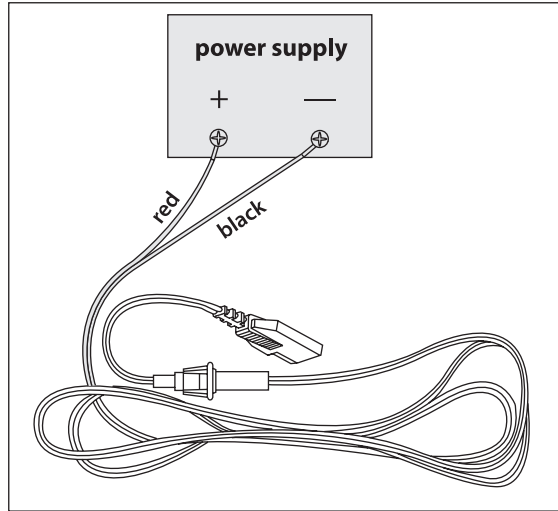

- 1 Simply connect the red (+) and black (-) leads of the transceiver to the corresponding terminals of the power pack.

Temporary Mobile Set-Up

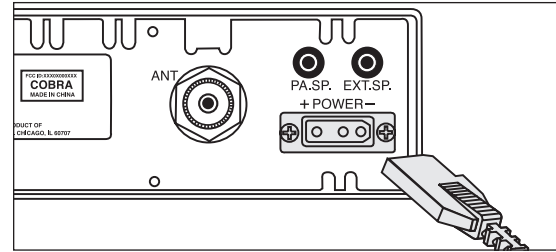

- 2 Plug the power cable into the jack marked "Power" on the back of the unit. Be sure to observe polarity markings.
- 3 Connect a properly installed and matched base station antenna.

Temporary Mobile Operation

For temporary mobile operation you may want to purchase an optional automobile power adapter. This adapter and a magnetic mount antenna allow you to quickly "install" your transceiver for temporary use.

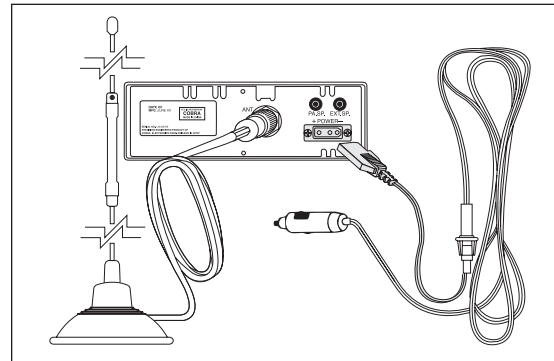

Temporary Mobile Set-Up

How Your CB Can Serve You

How Your CB Can Serve You

A Few Rules You Should Know

- Warn of traffic problems
- Provide weather and road data
- Provide help in event of an emergency
- Provide direct contact with home or office
- Assist police by reporting erratic drivers
- Get "local information" to find a destination
- Communicate with family and friends
- Suggest spots to eat and sleep
- Keep you alert while traveling

A Few Rules You Should Know

- A. Conversations cannot last more than 5 minutes with another station. A one minute break is required to let others use the channel.
- B. You cannot blast others off the air by use of illegally amplified transmitters or illegally high antennas.
- C. You cannot use a CB to promote illegal activities.
- D. Profanity is not allowed.
- E. You may not transmit music with a CB.
- F. Selling of merchandise and/or services is prohibited.

Channel 9 Emergency Messages

Note

If no response on channel 9, try channels 19 or 14.

1. Set to channel 9 for emergencies

Be sure the antenna is properly connected.

2. CB Distress Data

When transmitting an emergency, you should request a "REACT BASE" and provide the CB distress data (called **CLIP**):

- | | |
|-------------------|--------------------------------------|
| C all Sign | <i>Identify yourself.</i> |
| L ocation | <i>Be exact.</i> |
| I njuries | <i>Number. Type. Trapped?</i> |
| P roblem | <i>Give details and help needed.</i> |

Transmit **CLIP** repeatedly so any monitor can assist.

The FCC gives these examples of permitted and prohibited messages for channel 9. These are only guidelines and not all-inclusive:

Permitted	Example Message
Yes	"Tornado sighted six miles north of town."
No	"Post number 10. No tornado sighted."
Yes	"Out of gas on I-95 at mile marker 211."
No	"Out of gas in my driveway."
Yes	"Four car accident on I-94 at Exit 11. Send police and ambulance."
No	"Traffic moving smoothly on I-94."
Yes	"Weather Bureau has issued thunderstorm warning. Bring sailboat into port."
No	"Attention motorists. Weather Bureau advises snow tomorrow will accumulate 4 to 6 inches."
Yes	"Fire in building at 539 Main, Evanston."
No	"Halloween patrol number 3. All quiet."

How Your CB Can Serve You

CB 10-Codes

CB 10-Codes

Citizen Bands have adopted the "10-CODES" for standard questions and answers. These codes provide quick and easy communication, especially in noisy areas. Following are some of the more common codes and meanings:

Code	Meaning
10-1	Receiving poorly
10-2	Receiving well
10-3	Stop transmitting
10-4	OK, message received
10-5	Relay message
10-6	Busy, stand by
10-7	Out of service, leaving
10-8	In service, subject to call
10-9	Repeat message
10-10	Transmission completed standing by
10-11	Talking too rapidly
10-12	Visitors present
10-13	Advise weather/roads
10-16	Make pick up at
10-17	Urgent business
10-18	Anything for us?
10-19	Return to base
10-20	My location is
10-21	Call by phone
10-22	Report in person to
10-23	Stand by
10-24	Completed last assignment
10-25	Can you contact
10-26	Disregard last info
10-27	Moving to channel
10-28	Identify your station

How Your CB Can Serve You

Code	Meaning
10-29	Time is up for contact
10-30	Does not conform to FCC rules
10-33	Emergency traffic
10-34	Trouble at this station
10-35	Confidential information
10-36	Correct time is
10-37	Wrecker needed at
10-38	Ambulance needed
10-39	Message delivered
10-41	Turn to channel
10-42	Traffic accident at
10-43	Traffic tie up at
10-44	Have a message for
10-45	All units within range please report
10-50	Break channel
10-60	What is next message number?
10-62	Unable to copy. Use phone
10-63	Net directed to
10-64	Net clear
10-65	Awaiting your next message/assignment
10-67	All units comply
10-70	Fire at
10-71	Proceed, transmission in sequence
10-77	Negative contact
10-81	Reserve hotel room for
10-82	Reserve room for
10-85	My address is
10-91	Talk closer to mic
10-93	Check my frequency on this channel
10-94	Give me a long count
10-99	Mission completed, all units secure
10-200	Police needed at

FCC Statement

FCC Part 15.19 Warning Statement

THIS DEVICE COMPLIES WITH PART 15 OF THE FCC RULES. OPERATION IS SUBJECT TO THE FOLLOWING TWO CONDITIONS: (1) THIS DEVICE MAY NOT CAUSE HARMFUL INTERFERENCE, AND (2) THIS DEVICE MUST ACCEPT ANY INTERFERENCE RECEIVED, INCLUDING INTERFERENCE THAT MAY CAUSE UNDESIRE OPERATION.

FCC Part 15.21 Warning Statement-

NOTE: THE GRANTEE IS NOT RESPONSIBLE FOR ANY CHANGES OR MODIFICATIONS NOT EXPRESSLY APPROVED BY THE PARTY RESPONSIBLE FOR COMPLIANCE. SUCH MODIFICATIONS COULD VOID THE USER'S AUTHORITY TO OPERATE THE EQUIPMENT.

FCC Part 15.105(b) Warning Statement

NOTE: This equipment has been tested and found to comply with the limits for a Class B digital device, pursuant to part 15 of the FCC Rules. These limits are designed to provide reasonable protection against harmful interference in a residential installation. This equipment generates uses and can radiate radio frequency energy and, if not installed and used in accordance with the instructions, may cause harmful interference to radio communications. However, there is no guarantee that interference will not occur in a particular installation. If this equipment does cause harmful interference to radio or television reception, which can be determined by turning the equipment off and on, the user is encouraged to try to correct the interference by one or more of the following measures:

- Reorient or relocate the receiving antenna.
- Increase the separation between the equipment and receiver.
- Connect the equipment into an outlet on a circuit different from that to which the receiver is connected.
- Consult the dealer or an experienced radio/TV technician for help.

IC RSS-GEN, Sec 8.4 Warning Statement

ENGLISH: This device complies with Industry Canada license-exempt RSS standard(s). Operation is subject to the following two conditions: (1) this device may not cause interference, and (2) this device must accept any interference, including interference that may cause undesired operation of the device.

FRENCH: Le présent appareil est conforme aux CNR d'Industrie Canada applicables aux appareils radio exempts de licence. L'exploitation est autorisée aux deux conditions suivantes : (1) l'appareil ne doit pas produire de brouillage, et (2) l'utilisateur de l'appareil doit accepter tout brouillage radioélectrique subi, même si le brouillage est susceptible d'en compromettre le fonctionnement.

IC RSS-GEN, Sec 8.3 Warning Statement

ENGLISH: This radio transmitter (identify the device by certification number, or model number if Category II) has been approved by Industry Canada to operate with the antenna types listed below with the maximum permissible gain and required antenna impedance for each antenna type indicated. Antenna types not included in this list, having a gain greater than the maximum gain indicated for that type, are strictly prohibited for use with this device.

Immediately following the above notice, the manufacturer shall provide a list of all antenna types approved for use with the transmitter, indicating the maximum permissible antenna gain (in dBi) and required impedance for each.

FRENCH: Le présent émetteur radio (identifier le dispositif par son numéro de certification ou son numéro de modèle s'il fait partie du matériel de catégorie I) a été approuvé par Industrie Canada pour fonctionner avec les types d'antenne énumérés ci-dessous et ayant un gain admissible maximal et l'impédance requise pour chaque type d'antenne. Les types d'antenne non inclus dans cette liste, ou dont le gain est supérieur au gain maximal indiqué, sont strictement interdits pour l'exploitation de l'émetteur.

Limited Two Year Warranty

Product Service

Warranty Terms:

Cobra warrants your product against all defects in materials and workmanship for a period of two (2) years from the date of original purchase.

Cobra, at our sole discretion, will repair or replace your product (with the same or comparable product) free of charge.

Cobra will not pay shipping charges that you incur for sending your product to us. Products received COD will be refused.

To make a warranty claim, we will require proof of purchase in the form of an invoice or receipt. No proof of purchase is required for factory direct purchases.

Warranty Exclusions: Warranty does not apply to your product under any of the following conditions: 1. The serial number has been removed or modified. 2. Your product has been subjected to misuse or damage (including water damage, physical abuse, and/or improper installation). 3. Your product has been modified in any way. 4. Your receipt or proof-of-purchase is from a non-authorized dealer or internet auction site including E-bay, U-bid, or other non-authorized resellers.

LIMITATION OF WARRANTY: EXCEPT AS EXPRESSLY PROVIDED HEREIN, YOU ARE ACQUIRING THE PRODUCT "AS IS" AND "WHERE IS", WITHOUT REPRESENTATION OR WARRANTY. COBRA SPECIFICALLY DISCLAIMS ANY REPRESENTATION OR WARRANTY INCLUDING, BUT NOT LIMITED TO THOSE CONCERNING THE MERCHANTABILITY AND SUITABILITY OF THE PRODUCT FOR A PARTICULAR PURPOSE. COBRA SHALL NOT BE LIABLE FOR CONSEQUENTIAL, SPECIAL OR INCIDENTAL DAMAGES INCLUDING, WITHOUT LIMITATION, DAMAGES ARISING OUT OF THE USE, MISUSE OR MOUNTING OF THE PRODUCT.

The above limitations or exclusions shall be limited to the extent they violate the laws of any particular state. Cobra is not responsible for products lost in shipment between the owner and our service center.

General Warranty Information

Each product we manufacture is covered by our factory warranty. While each product may have unique components and policy, the general guideline below will apply to most Cobra products.

All Cobra products purchased factory-direct or from our Authorized Resellers will come with a full one to three (1-3) year warranty from the date of the original retail purchase (see policy statement above for full warranty details and exclusions).

Standard accessories packaged with each model will have a one-year factory warranty.

Accessory items have a one-year factory warranty.

Shipping to our facility is not covered in our warranty. Return shipping is included within the US.

This warranty is non-transferrable.

For the sake of clarity, 'repair or replace the Product or its defective part' does not include removal or installation work, costs or expenses which include but are not limited to labor costs or expenses.

Cobra will not be responsible for lost packages.

If you have any questions about operation or installing your new Cobra product, PLEASE CONTACT COBRA FIRST...do not return this product to any retail store.

The contact information for Cobra will vary depending on the country in which you purchased and utilize the product. For the latest contact information, please go to www.cobra.com/support

For products purchased in the U.S.A. you may call 800-543-1608.

For products purchased in the U.S.A., if your product should require factory service, please go to www.cobra.com/support and follow the instructions for returning your product to the Cobra Factory Service Department for service.

Should there be any problems with this product or further information is needed on its features please visit www.cobra.com for support, frequently asked questions, Declarations of Conformity, and full manuals.

For Products Purchased Outside the U.S.A. or Canada

Please contact your local dealer for product service information.

For Products Used in Canada Industry Canada Notice

This device complies with Industry Canada license-exempt RSS standard(s). Operation is subject to the following two conditions:

- (1) this device may not cause interference, and
- (2) this device must accept any interference, including interference that may cause undesired operation of the device.

Le présent appareil est conforme aux CNR d'Industrie Canada applicables aux appareils radio exempts de licence. L'exploitation est autorisée aux deux conditions suivantes:

- (1) l'appareil ne doit pas produire de brouillage, et
- (2) l'utilisateur de l'appareil doit accepter tout brouillage radioélectrique subi, même si le brouillage est susceptible d'en compromettre le fonctionnement.

Ordering Info

You can find quality Cobra products and accessories at your local Cobra dealer, or in the U.S.A., you can order directly from Cobra.

Please visit www.cobra.com

Web orders will normally ship the next business day if received by us before 2:00 PM Eastern Time. Orders do not ship on weekends or holidays. All standard deliveries are Monday-Friday only. Saturday delivery can be requested in certain areas of the country for an additional shipping fee by calling Sales at 800-543-1608.

Certain orders may require additional days to process prior to shipping. Holidays may also impact processing and shipping time frame. Occasionally, items may not ship due to inventory depletion. If you need your item to be expedited, we recommend calling Sales at 800-543-1608.

Order Acceptance

Once your order has been accepted and processed, you will receive an email that will include the shipping carrier and tracking information.

Shipping and Delivery

Free ground shipping is included to 48 states. Hawaii, Alaska and Puerto Rico ship based on assessed fee at checkout.

We require a physical address for shipping. Sorry, no P.O. Boxes or APO/FPO addresses. Please select 2-day or next day air for shipments to Hawaii or Alaska. Shipping charges are calculated on a per-product basis. Please make note of the shipping charges associated with each item.

Note: For safety reasons, we cannot ship products containing lithium-ion batteries via air delivery methods. These items are available to ship via ground service only.

Note: For your protection, some orders may require a signature for delivery.

29 LTD CLASSIC

Professional CB Radio

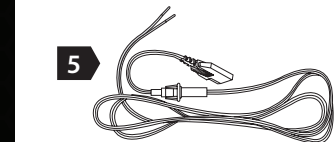
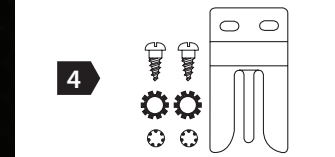
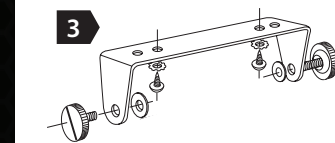
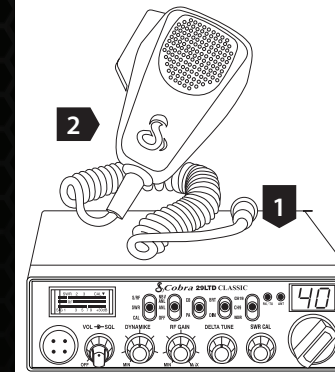

The Citizens Band lies between the shortwave broadcast and 10-meter Amateur radio bands, and was established by law in 1949. The Class D two-way communications service was opened in 1959. (CB also includes a Class A citizens band and Class C remote control frequencies.)

Federal Communications FCC Regulations
FCC regulations permit only "transmissions" (one party to another) rather than "broadcasts" (to a wide audience). Thus, advertising is not allowed on CB Channels because that is "broadcasting."

FCC Warnings
All transmitter adjustments other than those supplied by the manufacturer as front panel operating controls, must be made by, or under the supervision of, the holder of an FCC-issued general Radio-Telephone Operator's License.

Replacement or substitution of transistors, regular diodes or other parts of a unique nature, with parts other than those recommended by Cobra, may cause violation of the technical regulations of Part 95 of the FCC Rules, or violation of Type Acceptance requirements of Part 2 of the Rules.

- What's Included with Your 29 LTD Classic**
- 1 CB Transceiver
 - 2 Microphone
 - 3 Transceiver Bracket
 - 4 Microphone Bracket
 - 5 DC Power Cord
 - 6 Operating Manual

For more information or to order any of our products, please visit our website: www.cobra.com

©2020 Cobra Electronics Corporation

Cobra®, Dynamike®, Nothing Comes Close to a Cobra® and the snake design are registered trademarks of Cobra Electronics Corporation, USA.
Cobra Electronics Corporation™ is a trademark of Cobra Electronics Corporation, USA.

Pat. www.cobra.com/patents

OWNER'S MANUAL

Nothing Comes Close to a Cobra®

Controls and Indicators

Our Thanks to You

Notes

- 1 4-Pin Microphone Connector
- 2 Power On/Off/Volume/ Squelch Control
- 3 Dynamike®
- 4 RF Gain
- 5 Delta-Tune
- 6 SWR CAL
- 7 Channel Selector
- 8 LED Channel Display
- 9 ANT LED Indicator
- 10 RX (Receive)/TX (Transmit) LED Indicator
- 11 Channel 9/19/Normal Switch
- 12 Bright/Dim Switch
- 13 CB/PA Switch
- 14 NB/ANL ANL Off Switch
- 15 S/RF SWR CAL Switch
- 16 Signal Strength Meter
- 17 Microphone

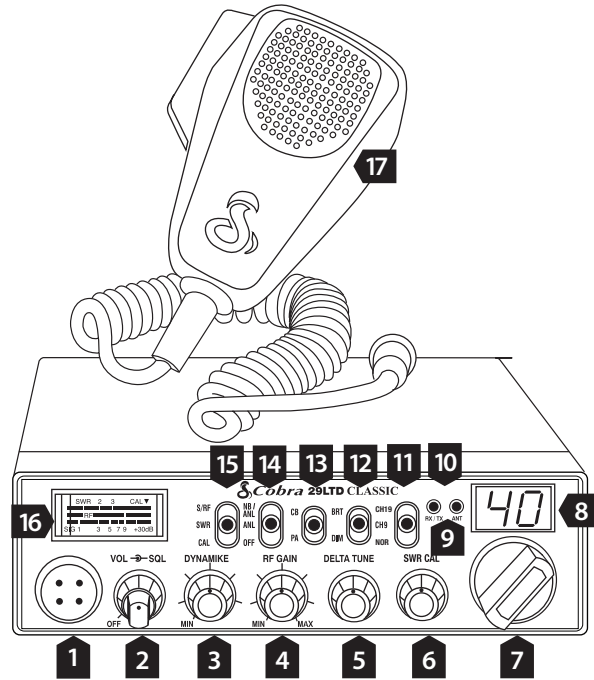

Back Side

- 18 Public Address Speaker Jack
- 19 External Speaker Jack
- 20 Antenna Connector
- 21 Power Jack

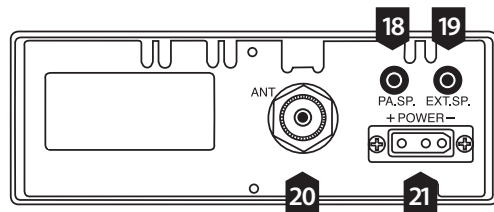

Thank you for purchasing the Cobra 29 LTD Classic CB Radio. Properly used, this Cobra product will give you many years of reliable service.

Customer Support

Should you encounter any problems with the product or not understand its many features, please refer to this owner's manual. If, after referring to the manual, you still need help, call Cobra Customer Service at 800-543-1608.

Cobra Assistance

Should you encounter any problems with this product, or not understand its many features, please refer to this owner's manual. If you require further assistance after reading this manual, Cobra Electronics offers the following customer assistance services:

Monday-Friday 9:00 AM-5:00 PM EST

Call: 800-543-1608

SERVICE

Monday-Thursday
9:00AM-5:00PM EST

Call: 800-543-1608

Office:

6500 West Cortland Street,
Chicago, IL, 60707

Have questions? We can help.

Contact us at 800-543-1608

M-F 9:00AM-5PM EST

For Assistance Outside the U.S.A.

Contact Your Local Dealer