



The optimal tools for your industry™



Company Profile

Carmex Precision Tools Ltd. is a leading manufacturer of high quality cutting tools.

The company was founded in 1988 in Maalot, located in the beautiful North West region of Israel.

Product Lines

Carmex specializes in the production of threading tools for turning and milling. Our product lines include Thread Turning inserts and toolholders, Mill-Thread inserts and toolholders, Mill-Thread Solid Carbide and Spiral Mill-Thread. In addition to threading, we produce Grooving tools, Mini Chamfer mills, Swiss Tools and the Tiny Tools line of small boring bars for threading, turning and grooving of small parts. The company's different product lines are recognized worldwide for their advanced technology, reliable full range lines that offer accurate geometry, excellent cutting performance and extended tool life. Our products and service we provide live up to the highest standards and outperform them. Carmex also produces special tools in accordance with the customer's requirements.

Quality Assurance

In addition to our unyielding strive for high quality, speedy service and reliability, Carmex is certified by ISO 9001:2015, ISO 13485:2003, ISO 14001:2015, OHSAS 18001 and CE. Most of our customers' requirements are supplied immediately from our readily available wide range of inventory as well as from our agents and distributor's stocks around the world. In August 2008 Carmex completed its transfer to the new, state-of-the-art modern building. In addition to the construction we invested in advanced machinery and equipment as part of our strategy to keep our position in the first line of high technology.

Carmex Branches

In addition to its distributor's chain, Carmex has three independent sales branches. Each of them keeps Carmex's wide range of stock and employs talented, service oriented managers, engineers, technicians and administrators willing to fulfill the customers' needs.

2003 - C.P.T. GmbH, a sales branch in Stuttgart Germany serving Europe.

2004 - Carmex Precision Tools, LLC, a sales branch in Wisconsin USA serving North America and Mexico.

2008 - Carmex Italia Srl, a sales branch in Modena, Italy.

In addition to our customers' recognition of our high quality tools, we are well known as a service oriented company and as a very competitive supplier that pledge for customer satisfaction.



THE STANDARDS INSTITUTION OF ISRAEL

ISO 9001-2015
Quality Management
Systems



THE STANDARDS INSTITUTION OF ISRAEL

ISO 13485:2003
Medical Devices
Quality Management
Systems



THE STANDARDS INSTITUTION OF ISRAEL

ISO 14001
Environmental
Management
Systems



THE STANDARDS INSTITUTION OF ISRAEL

OHSAS 18001
Occupational
Health and Safety
Management Systems

CE 0470
European Conformity

EU consumer safety,
health and
environmental
requirements

Thread - Turning

New HBA Grade

A new extra-fine sub-micron grade with high toughness, for optimized performance on hardened steels and cast iron up to 62HRC, titanium alloys and super alloys (hastelloy, inconel and nickel based alloys). Available for inserts sizes: 11, 16, 22, 27.



Page: 66

Type B

Ground Profile with Sintered Chip breaker

- Size 11 mm inserts



Page: 10

New Profiles

- Insert for pac & Hughes thread.
- API 5B V-0.055 Macaroni Tubing.

Pages: 36 and 38

External Thread Turning Toolholder

with Internal Coolant

A top clamp directing the coolant flow to the cutting edge.



Page: 49

Quick Change

Polygon Threading Toolholders



Page: 50

Tiny Tools

MZL Bars - Face Grooving



Page: 102

CMR -

Carmex Multi-Task Tiny Tools



Page: 103

CBR - Boring

and Profiling With advanced Chip Breaker



Page: 104

HK -

Broaching Tools for Hexagon Keys



Page: 105

Square Shank Holders

For Swiss Type machines



Page: 111

New Products for most of the existing applications & new holders.

Page: 81-111

Mini Tools

- Carmex presents Mini Tools, a new generation of vertical inserts and toolholders for threading, chamfering, grooving and turning, from 8 mm min. diameter.

- Steel holders are also available.



Page: 117

Swiss Line

- Carmex is introducing a new line of inserts and toolholders, developed for automatic lathes and Swiss Type machines.
- Designed for economic parting, grooving, profiling and chamfering mass production.



Page: 129

Milling

Mini Spiral Mill - Thread

- Spiral fluted toolholders hold 1 to 3 inserts.
- Comparatively small cutting diameters.
- Reduced machining time.



Pages: 193-204

Deep Reach Mill - Thread

- Carmex modular holders are ideal for deep reach applications.
- Cost saving - Same shank can hold different heads.
- Screw connection allows long overhang.



Pages: 205-208

CMT - Vertical Milling

- Spiral multi flute inserts
- CMT multi inserts milling cutters



Pages: 209-234

FMT - Fast Mill - Thread

Carmex has designed a unique line of solid carbide thread milling tools for increased productivity and high performance.



Page: 248

EMT

Mill - Thread Solid Carbide for External Threads.



Page: 256-257

AMT

Solid carbide thread mills for High-speed Aluminum machining.



Page: 258

MTSB

New innovative solid carbide thread milling cutters with internal coolant Bore.

- High coolant pressure washes the chips away to help prevent recutting.
- High pressure coolant extends tool life.



Page: 269

MGD - Groove Milling

- With internal coolant through the flutes
- Same tool for Internal and External Grooving



Page: 312

CR - Supercut Roughers

- High Performance Cutting (HPC).
- Extremely high material removal rate.
- Indexable CMT roughers for excellent performance.



Page: 313-322

Main Content

Page:

Turning Tools

1-168

Milling Tools

169-328

Turning Tools

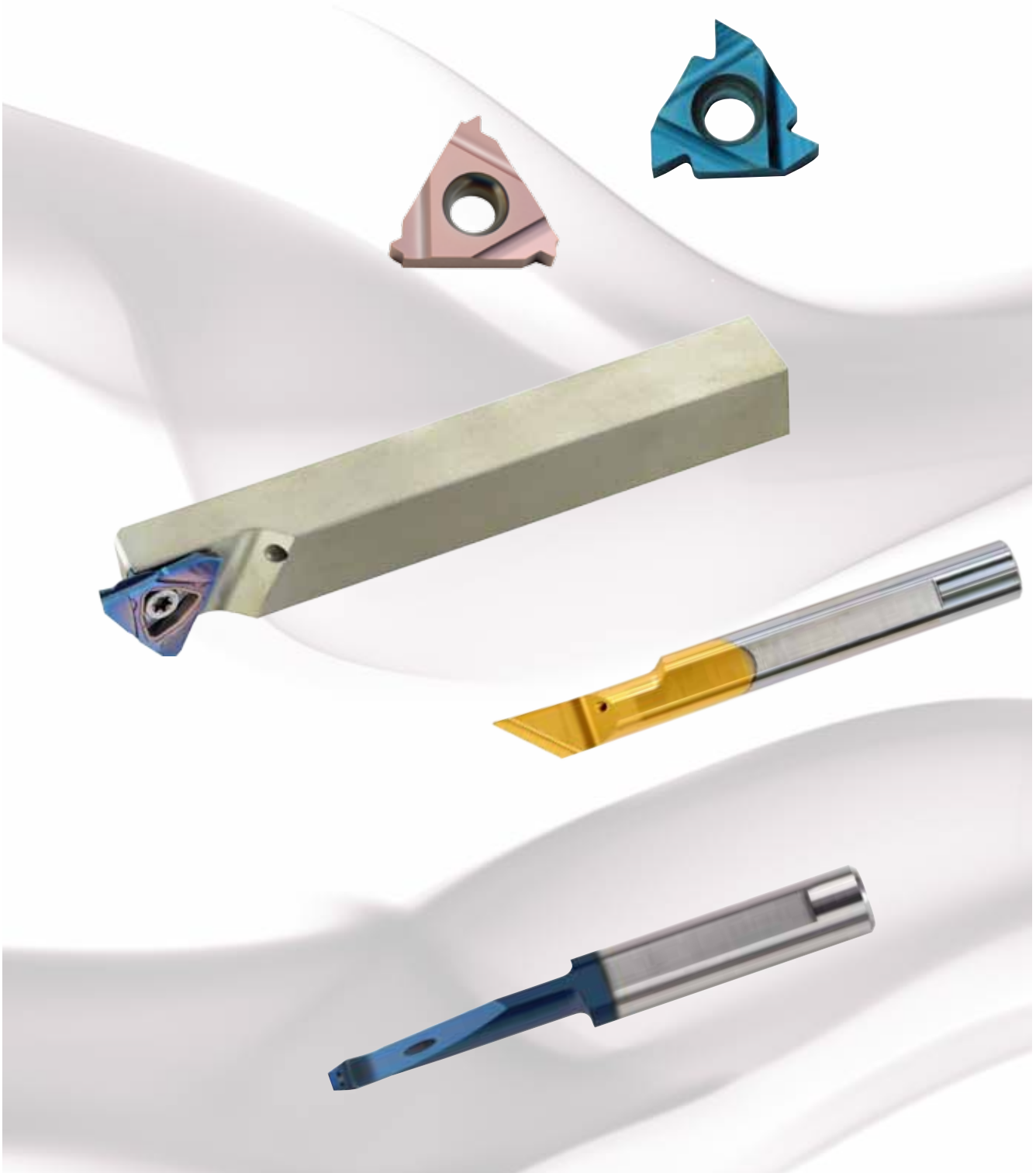

CONTENTS:	Page:	
Thread Turning Inserts	3-40	
Thread Turning Toolholders and Kits	41-58	
Double Sided Thread Turning Inserts and Toolholders	59-64	
Thread Turning Technical Section	65-74	
Grooving Tools	75-78	
Tiny Tools	79-116	
Mini Tools	117-128	
Swiss Line	129-162	
Carbide Shank Turning Toolholders and Insert	163-164	
Thread Whirling	165-168	

Thread Turning Inserts

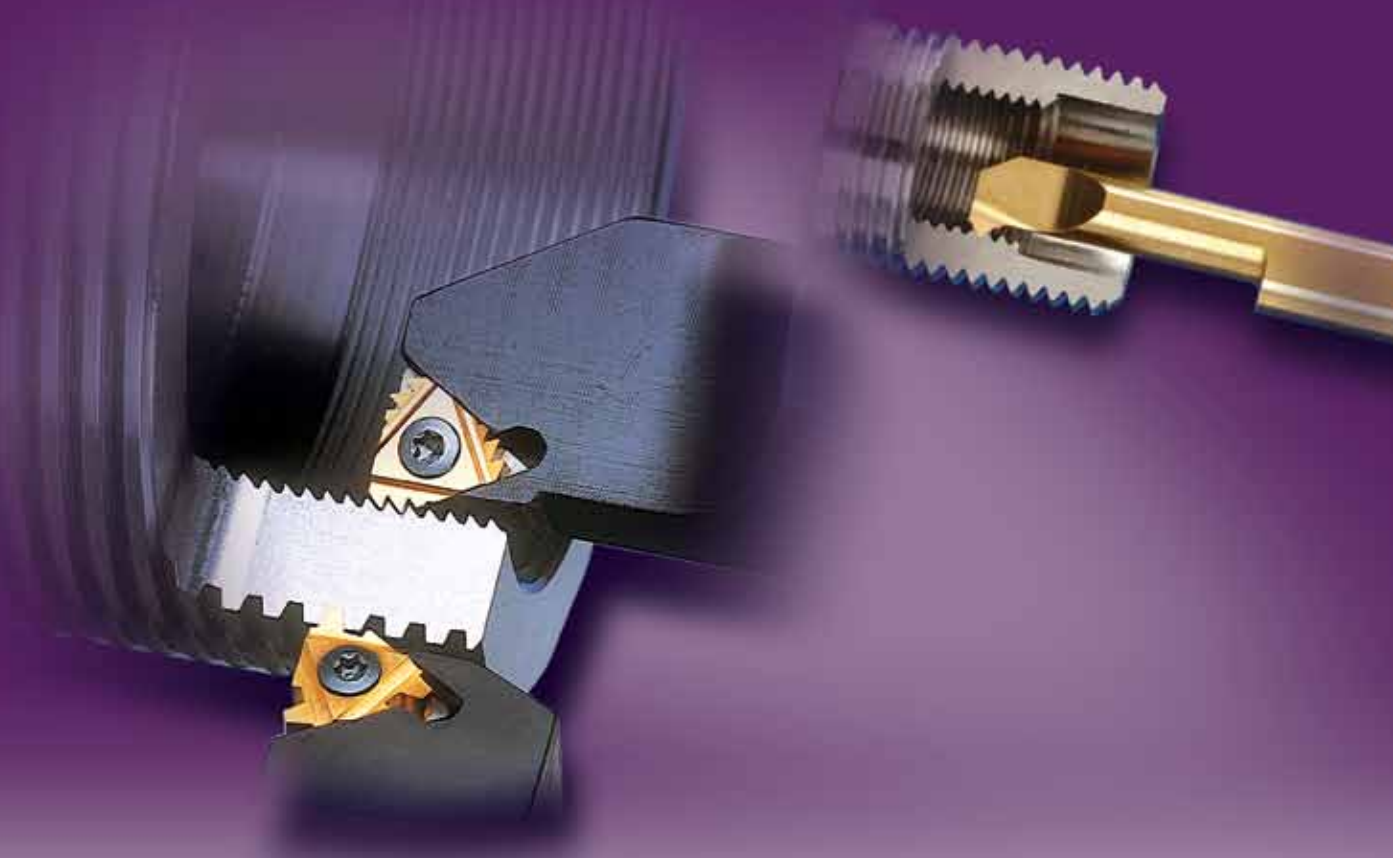

BLU Grade

A sub-micrograin grade with PVD triple layer coating. The BLU grade provides a combination of very high strength with high wear resistance.

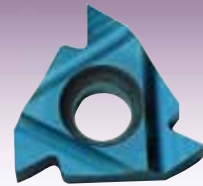

HBA Grade

An extra-fine sub-micron grade with high toughness, for optimized performance on Hardened Steels and Cast Iron up to 62HRc, Titanium Alloys and Super Alloys (Hastelloy, Inconel, and Nickel based alloys).



Contents:

Page:

Contents:

Page:

Product Identification 4
Partial Profile 60° 5-6
Partial Profile 55° 7-8
ISO - metric 9-11
UN - unified 12-15
Whitworth 55° 16-19
NPT 20-21
NPTF 22
BSPT 23-24
DIN 477 24
Acme 25
Stub Acme 26

Trapez - DIN 103 27
PG - DIN 40430 28
Sagengewinde- DIN 513 28
Round - DIN 405 29
Round - DIN 20400 29
UNJ 30-31
MJ - ISO 5855 32
American Buttress 33-34
Oil Threads 35-37
HUGHES 38
PAC 38
VAM 39

Product Identification

Thread Turning Inserts Ordering Codes

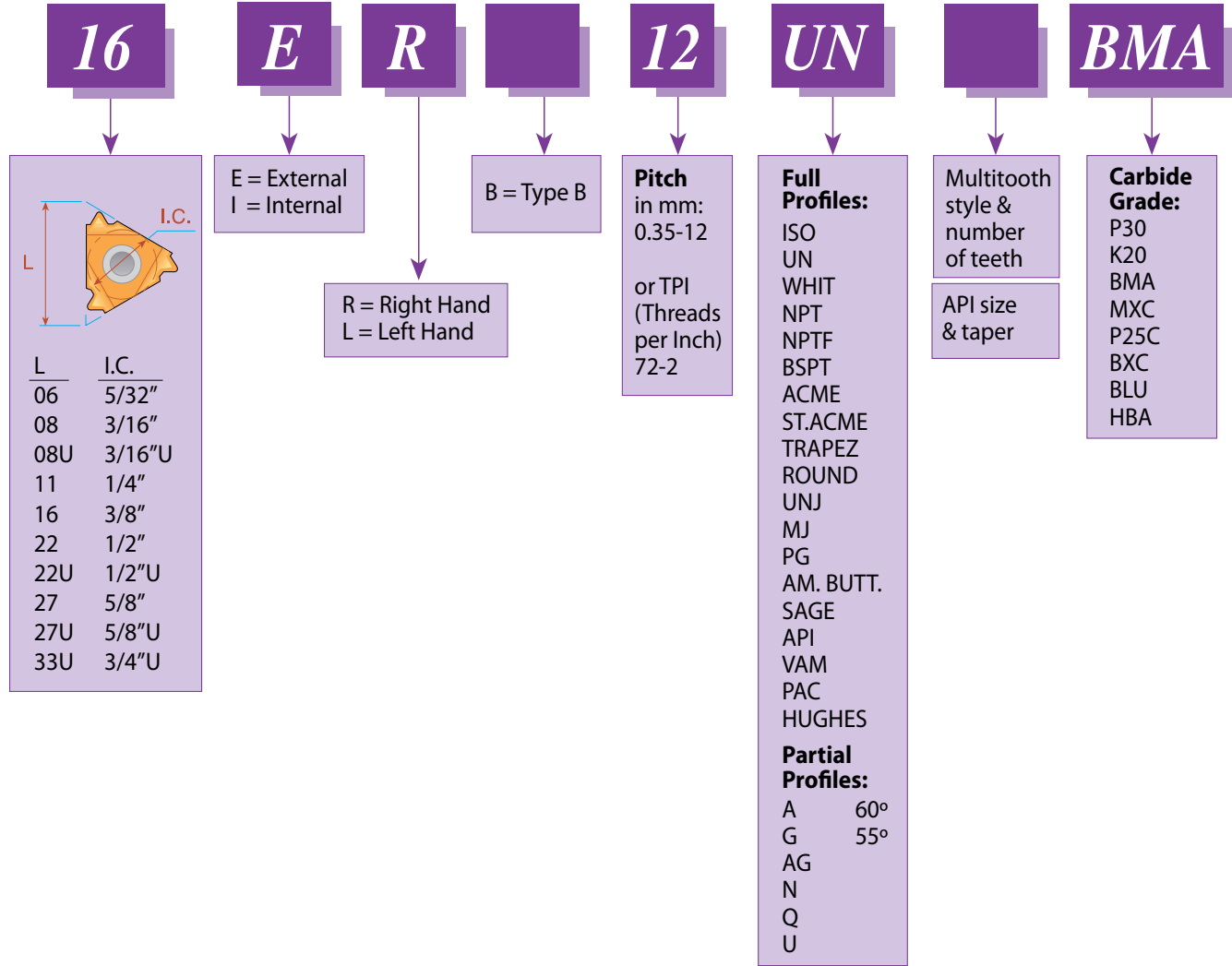

Partial Profile 60°

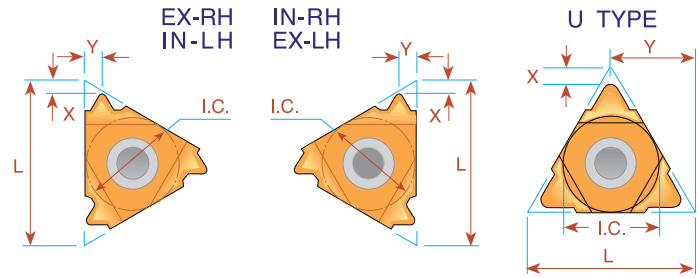
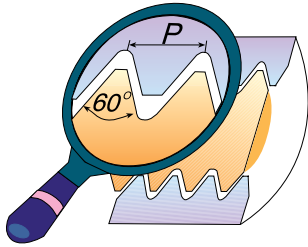

L mm	I.C.	Pitch Range		EXTERNAL Ordering Code		INTERNAL Ordering Code		X	Y
		mm	TPI	Right Hand	Left Hand	Right Hand	Left Hand		
6	5/32	0.5 -1.25	48-20	ULTRA MINIATURE →		*06 IR A60	*06 IL A60	.02	.02
8	3/16	0.5 -1.5	48-16	MINIATURE →		*08 IR A60	*08 IL A60	.02	.03
8U	3/16U	1.75-2.0	14-11	"U" MINIATURE →		*08U IR/L U60		.03	.16
11	1/4	0.5 -1.5	48-16	11 ER A60	11 EL A60	11 IR A60	11 IL A60	.03	.04
16	3/8	0.5 -1.5	48-16	16 ER A60	16 EL A60	16 IR A60	16 IL A60	.03	.04
16	3/8	1.75-3.0	14- 8	16 ER G60	16 EL G60	16 IR G60	16 IL G60	.05	.07
16	3/8	0.5 -3.0	48- 8	16 ER AG60	16 EL AG60	16 IR AG60	16 IL AG60	.05	.07
22	1/2	3.5 -5.0	7- 5	22 ER N60	22 EL N60	22 IR N60	22 IL N60	.07	.10
22U	1/2U	5.5 -8.0	4.5- 3.25	22U E/R/L U60				.02	.43
27	5/8	5.5 -6.0	4.5- 4	27 ER Q60	27 EL Q60	27 IR Q60	27 IL Q60	.08	.12
27U	5/8U	6.5 -9.0	4- 2.75	27U E/R/L U60				.04	.54

Order example: 16 ER G60 MXC

For small bore threading see page 88
 * Available only in BXC and BMA grade

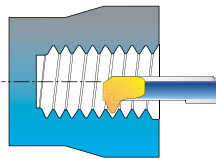

Type B Ground Profile with Sintered Chip-breaker



L mm	I.C.	Pitch Range		EXTERNAL Ordering Code	INTERNAL Ordering Code	X	Y
		mm	TPI	Right Hand	Right Hand		
16	3/8	0.5 -1.5	48-16	16 ER B A60	16 IR B A60	.03	.04
16	3/8	1.75-3.0	14- 8	16 ER B G60	16 IR B G60	.05	.07
16	3/8	0.5 -3.0	48- 8	16 ER B AG60	16 IR B AG60	.05	.07

Order example: 16 ER B G60 BMA

For Carbide Grade and Cutting Speed see page 66-67

Partial Profile 60° Vertical

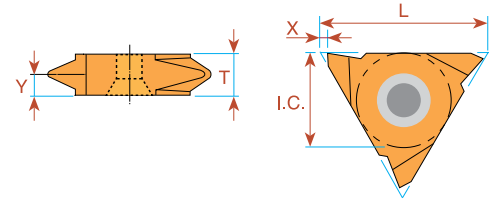

L mm	I.C.	Pitch Range		EXTERNAL Ordering Code		INTERNAL Ordering Code		X	Y	T
		mm	TPI	Right Hand	Left Hand	Right Hand	Left Hand			
16	3/8	0.5 - 1.5	48-16	16V ER A60	16V EL A60			.04	.04	.14
16	3/8	1.75- 3.0	14- 8	16V ER G60	16V EL G60			.04	.07	.14
16	3/8	0.5 - 3.0	48- 8	16V ER AG60	16V EL AG60			.04	.07	.14
22	1/2	1.75- 3.0	14- 8	22V ER G60	22V EL G60			.05	.07	.16
22	1/2	0.5 - 5.0	7- 5	22V ER N60	22V EL N60			.05	.10	.19
27	5/8	6.0 -10.0	4- 2.5	27V ER V60	27V EL V60	27V IR V60	27V IL V60	.07	.20	.41

Order example: 16V ER G60 BMA

For Carbide Grade and Cutting Speed see page 66-67

Partial Profile 55°

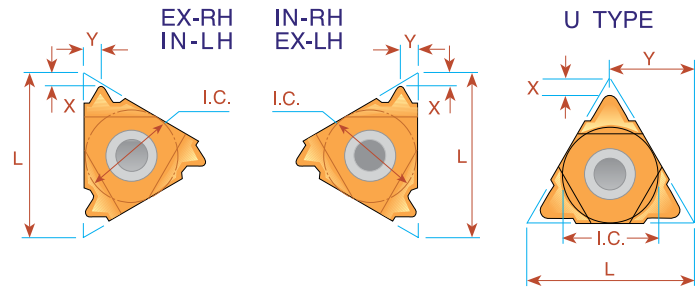
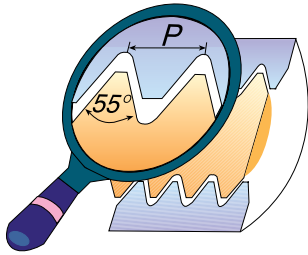

L mm	I.C.	Pitch Range		EXTERNAL		INTERNAL		X	Y
		mm	TPI	Ordering Code Right Hand	Ordering Code Left Hand	Ordering Code Right Hand	Ordering Code Left Hand		
6	5/32	0.5 -1.25	48-20	<i>ULTRA MINIATURE</i> →		*06 IR A55	*06 IL A55	.02	.02
8	3/16	0.5 -1.5	48-16	<i>MINIATURE</i> →		*08 IR A55	*08 IL A55	.02	.03
8U	3/16U	1.75-2.0	14-11	<i>"U" MINIATURE</i> →		*08U IR/L U55		.03	.16
11	1/4	0.5 -1.5	48-16	11 ER A55	11 EL A55	11 IR A55	11 IL A55	.03	.04
16	3/8	0.5 -1.5	48-16	16 ER A55	16 EL A55	16 IR A55	16 IL A55	.03	.04
16	3/8	1.75-3.0	14- 8	16 ER G55	16 EL G55	16 IR G55	16 IL G55	.05	.07
16	3/8	0.5 -3.0	48- 8	16 ER AG55	16 EL AG55	16 IR AG55	16 IL AG55	.05	.07
22	1/2	3.5 -5.0	7- 5	22 ER N55	22 EL N55	22 IR N55	22 IL N55	.07	.10
22U	1/2U	5.5 -8.0	4.5- 3.25	22U E/R/L U55				.04	.43
27	5/8	5.5 -6.0	4.5- 4	27 ER Q55	27 EL Q55	27 IR Q55	27 IL Q55	.08	.11
27U	5/8U	6.5 -9.0	4 - 2.75	27U E/R/L U55				.05	.54

Order example: 16 ER G55 MXC

For small bore threading see page 88
* Available only in BXC and BMA grades

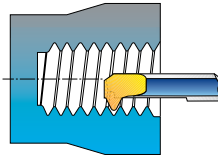

Type B Ground Profile with Sintered Chip-breaker



L mm	I.C.	Pitch Range		EXTERNAL	INTERNAL	X	Y
		mm	TPI	Ordering Code Right Hand	Ordering Code Right Hand		
16	3/8	1.75-3.0	14-8	16 ER B G55	16 IR B G55	.05	.07
16	3/8	0.5-3.0	48-8	16 ER B AG55	16 IR B AG55	.05	.07

Order example: 16 ER B G55 BMA

For Carbide Grade and Cutting Speed see page 66-67

Partial Profile 55° Vertical

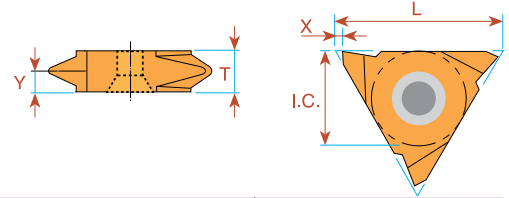

L mm	I.C.	Pitch Range		EXTERNAL Ordering Code		INTERNAL Ordering Code		X	Y	T
		mm	TPI	Right Hand	Left Hand	Right Hand	Left Hand			
16	3/8	0.5 - 1.5	48-16	16V ER A55	16V EL A55			.04	.04	.14
16	3/8	1.75- 3.0	14- 8	16V ER G55	16V EL G55			.04	.07	.14
16	3/8	0.5 - 3.0	48- 8	16V ER AG55	16V EL AG55			.04	.07	.14
22	1/2	3.5 - 5.0	7- 5	22V ER N55	22V EL N55			.05	.10	.19
27	5/8	6.0-10.0	4- 2.5	27V ER V55	27V EL V55	27V IR V55	27V IL V55	.07	.20	.41

Order example: 22V ER N55 BMA

For Carbide Grade and Cutting Speed see page 66-67

ISO - metric

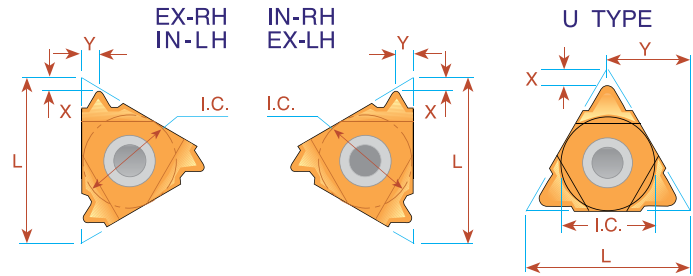
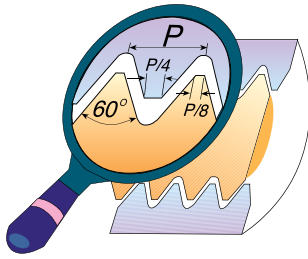

Pitch mm	L mm	I.C.	EXTERNAL		X	Y	INTERNAL		X	Y
			Ordering Code Right Hand	Ordering Code Left Hand			Ordering Code Right Hand	Ordering Code Left Hand		
0.5	6	5/32	<i>ULTRA MINIATURE</i> →				*06 IR 0.5 ISO	*06 IL 0.5 ISO	.04	.02
0.75	6	5/32					*06 IR 0.75 ISO	*06 IL 0.75 ISO	.03	.02
1.0	6	5/32					*06 IR 1.0 ISO	*06 IL 1.0 ISO	.03	.02
1.25	6	5/32					*06 IR 1.25 ISO	*06 IL 1.25 ISO	.02	.02
0.5	8	3/16	<i>MINIATURE</i> →				*08 IR 0.5 ISO	*08 IL 0.5 ISO	.02	.02
0.75	8	3/16					*08 IR 0.75 ISO	*08 IL 0.75 ISO	.02	.02
1.0	8	3/16					*08 IR 1.0 ISO	*08 IL 1.0 ISO	.02	.02
1.25	8	3/16					*08 IR 1.25 ISO	*08 IL 1.25 ISO	.02	.03
1.5	8	3/16					*08 IR 1.5 ISO	*08 IL 1.5 ISO	.02	.03
1.75	8	3/16					*08 IR 1.75 ISO	*08 IL 1.75 ISO	.02	.03
2.0	8U	3/16U	<i>"U" MINIATURE</i> →				*08U IR/L 2.0 ISO		.04	.16
0.35	11	1/4	11 ER 0.35 ISO	11 EL 0.35 ISO	.03	.02	11 IR 0.35 ISO	11 IL 0.35 ISO	.03	.01
0.4	11	1/4	11 ER 0.4 ISO	11 EL 0.4 ISO	.03	.02	11 IR 0.4 ISO	11 IL 0.4 ISO	.03	.02
0.45	11	1/4	11 ER 0.45 ISO	11 EL 0.45 ISO	.03	.02	11 IR 0.45 ISO	11 IL 0.45 ISO	.03	.02
0.5	11	1/4	11 ER 0.5 ISO	11 EL 0.5 ISO	.02	.02	11 IR 0.5 ISO	11 IL 0.5 ISO	.02	.02
0.6	11	1/4	11 ER 0.6 ISO	11 EL 0.6 ISO	.02	.02	11 IR 0.6 ISO	11 IL 0.6 ISO	.02	.02
0.7	11	1/4	11 ER 0.7 ISO	11 EL 0.7 ISO	.02	.02	11 IR 0.7 ISO	11 IL 0.7 ISO	.02	.02
0.75	11	1/4	11 ER 0.75 ISO	11 EL 0.75 ISO	.02	.02	11 IR 0.75 ISO	11 IL 0.75 ISO	.02	.02
0.8	11	1/4	11 ER 0.8 ISO	11 EL 0.8 ISO	.02	.02	11 IR 0.8 ISO	11 IL 0.8 ISO	.02	.02
1.0	11	1/4	11 ER 1.0 ISO	11 EL 1.0 ISO	.03	.03	11 IR 1.0 ISO	11 IL 1.0 ISO	.02	.03
1.25	11	1/4	11 ER 1.25 ISO	11 EL 1.25 ISO	.03	.04	11 IR 1.25 ISO	11 IL 1.25 ISO	.03	.03
1.5	11	1/4	11 ER 1.5 ISO	11 EL 1.5 ISO	.03	.04	11 IR 1.5 ISO	11 IL 1.5 ISO	.03	.04
1.75	11	1/4	11 ER 1.75 ISO	11 EL 1.75 ISO	.03	.04	11 IR 1.75 ISO	11 IL 1.75 ISO	.03	.04
2.0	11	1/4	11 ER 2.0 ISO	11 EL 2.0 ISO	.03	.04	11 IR 2.0 ISO	11 IL 2.0 ISO	.03	.04
2.5	11	1/4					11 IR 2.5 ISO	11 IL 2.5 ISO	.03	.05
0.35	16	3/8	16 ER 0.35 ISO	16 EL 0.35 ISO	.03	.02	16 IR 0.35 ISO	16 IL 0.35 ISO	.03	.01
0.4	16	3/8	16 ER 0.4 ISO	16 EL 0.4 ISO	.03	.02	16 IR 0.4 ISO	16 IL 0.4 ISO	.03	.02
0.45	16	3/8	16 ER 0.45 ISO	16 EL 0.45 ISO	.03	.02	16 IR 0.45 ISO	16 IL 0.45 ISO	.03	.02
0.5	16	3/8	16 ER 0.5 ISO	16 EL 0.5 ISO	.02	.02	16 IR 0.5 ISO	16 IL 0.5 ISO	.02	.02
0.6	16	3/8	16 ER 0.6 ISO	16 EL 0.6 ISO	.02	.02	16 IR 0.6 ISO	16 IL 0.6 ISO	.02	.02
0.7	16	3/8	16 ER 0.7 ISO	16 EL 0.7 ISO	.02	.02	16 IR 0.7 ISO	16 IL 0.7 ISO	.02	.02
0.75	16	3/8	16 ER 0.75 ISO	16 EL 0.75 ISO	.02	.02	16 IR 0.75 ISO	16 IL 0.75 ISO	.02	.02
0.8	16	3/8	16 ER 0.8 ISO	16 EL 0.8 ISO	.02	.02	16 IR 0.8 ISO	16 IL 0.8 ISO	.02	.02
1.0	16	3/8	16 ER 1.0 ISO	16 EL 1.0 ISO	.03	.03	16 IR 1.0 ISO	16 IL 1.0 ISO	.02	.03
1.25	16	3/8	16 ER 1.25 ISO	16 EL 1.25 ISO	.03	.04	16 IR 1.25 ISO	16 IL 1.25 ISO	.03	.03
1.5	16	3/8	16 ER 1.5 ISO	16 EL 1.5 ISO	.03	.04	16 IR 1.5 ISO	16 IL 1.5 ISO	.03	.04
1.75	16	3/8	16 ER 1.75 ISO	16 EL 1.75 ISO	.04	.05	16 IR 1.75 ISO	16 IL 1.75 ISO	.04	.05
2.0	16	3/8	16 ER 2.0 ISO	16 EL 2.0 ISO	.04	.05	16 IR 2.0 ISO	16 IL 2.0 ISO	.04	.05
2.5	16	3/8	16 ER 2.5 ISO	16 EL 2.5 ISO	.04	.06	16 IR 2.5 ISO	16 IL 2.5 ISO	.04	.06
3.0	16	3/8	16 ER 3.0 ISO	16 EL 3.0 ISO	.05	.06	16 IR 3.0 ISO	16 IL 3.0 ISO	.04	.06
3.5	16	3/8	16 ER 3.5 ISO	16 EL 3.5 ISO	.05	.06	16 IR 3.5 ISO	16 IL 3.5 ISO	.05	.07

* Available only in BXC and BMA grades

ISO - metric

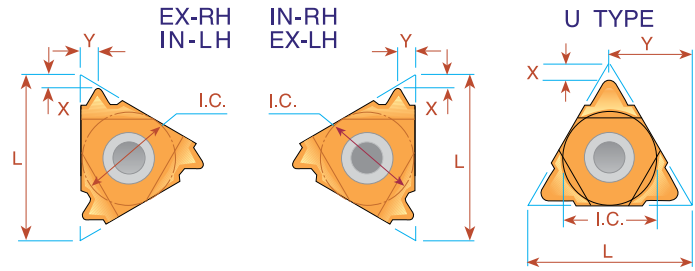
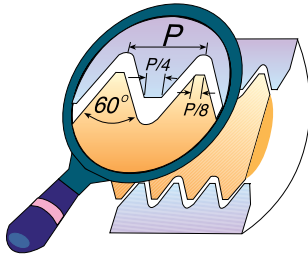

Pitch mm	L mm	I.C.	EXTERNAL				INTERNAL			
			Ordering Code		X	Y	Ordering Code		X	Y
Right Hand	Left Hand	Right Hand	Left Hand	Right Hand			Left Hand			
3.5	22	1/2	22 ER 3.5 ISO	22 EL 3.5 ISO	.06	.09	22 IR 3.5 ISO	22 IL 3.5 ISO	.06	.09
4.0	22	1/2	22 ER 4.0 ISO	22 EL 4.0 ISO	.06	.09	22 IR 4.0 ISO	22 IL 4.0 ISO	.06	.09
4.5	22	1/2	22 ER 4.5 ISO	22 EL 4.5 ISO	.07	.09	22 IR 4.5 ISO	22 IL 4.5 ISO	.06	.09
5.0	22	1/2	22 ER 5.0 ISO	22 EL 5.0 ISO	.07	.10	22 IR 5.0 ISO	22 IL 5.0 ISO	.06	.09
5.5	22	1/2	22 ER 5.5 ISO	22 EL 5.5 ISO	.07	.10	22 IR 5.5 ISO	22 IL 5.5 ISO	.06	.09
6.0	22	1/2	*22 ER 6.0 ISO	*22 EL 6.0 ISO	.07	.11	22 IR 6.0 ISO	22 IL 6.0 ISO	.06	.09
5.5	22U	1/2U	22U ER/L 5.5 ISO		.09	.43	22U IR/L 5.5 ISO		.09	.43
6.0	22U	1/2U	22U ER/L 6.0 ISO		.10	.43	22U IR/L 6.0 ISO		.08	.43
5.5	27	5/8	27 ER 5.5 ISO	27 EL 5.5 ISO	.07	.11	27 IR 5.5 ISO	27 IL 5.5 ISO	.06	.09
6.0	27	5/8	27 ER 6.0 ISO	27 EL 6.0 ISO	.08	.11	27 IR 6.0 ISO	27 IL 6.0 ISO	.07	.10
8.0	27U	5/8U	27U ER/L 8.0 ISO		.09	.54	27U IR/L 8.0 ISO		.09	.54
12.0	33U	3/4U	33U ER/L 12.0 ISO		.10	.65	33U IR/L 12.0 ISO		.14	.67

Order example: 22 IR 3.5 ISO BMA

* Special holder required

For small bore threading see page 89

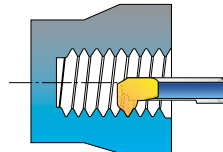

Type B

Ground Profile with Sintered Chip-breaker

Pitch mm	L	I.C. in	EXTERNAL			INTERNAL		
			Ordering Code	X	Y	Ordering Code	X	Y
Right Hand	Right Hand	Right Hand						
0.5	11	1/4				11 IR B 0.5 ISO	.02	.02
0.75	11	1/4				11 IR B 0.75 ISO	.02	.02
0.8	11	1/4				11 IR B 0.8 ISO	.02	.02
1.0	11	1/4				11 IR B 1.0 ISO	.02	.02
1.25	11	1/4				11 IR B 1.25 ISO	.03	.04
1.5	11	1/4				11 IR B 1.5 ISO	.03	.04
1.75	11	1/4				11 IR B 1.75 ISO	.03	.04
2.0	11	1/4				11 IR B 2.0 ISO	.03	.04
0.8	16	3/8	16 ER B 0.8 ISO	.02	.02			
1.0	16	3/8	16 ER B 1.0 ISO	.03	.03	16 IR B 1.0 ISO	.02	.03
1.25	16	3/8	16 ER B 1.25 ISO	.03	.04	16 IR B 1.25 ISO	.03	.03
1.5	16	3/8	16 ER B 1.5 ISO	.03	.04	16 IR B 1.5 ISO	.03	.04
1.75	16	3/8	16 ER B 1.75 ISO	.04	.05	16 IR B 1.75 ISO	.04	.05
2.0	16	3/8	16 ER B 2.0 ISO	.04	.05	16 IR B 2.0 ISO	.04	.05
2.5	16	3/8	16 ER B 2.5 ISO	.04	.06	16 IR B 2.5 ISO	.04	.06
3.0	16	3/8	16 ER B 3.0 ISO	.05	.06	16 IR B 3.0 ISO	.04	.06

Order example: 16 IR B 1.5 ISO BMA

For Carbide Grade and Cutting Speed see page 66-67

ISO - metric Vertical

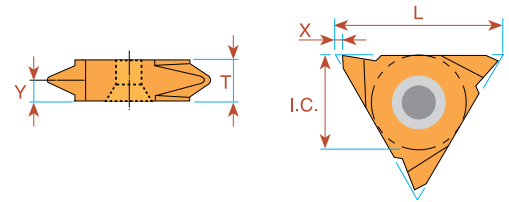

Pitch mm	L mm	I.C.	EXTERNAL		INTERNAL		X	Y	T
			Right Hand	Left Hand	Right Hand	Left Hand			
0.5	16	3/8	16V ER 0.5 ISO	16V EL 0.5 ISO			.04	.02	.14
0.75	16	3/8	16V ER 0.75 ISO	16V EL 0.75 ISO			.04	.02	.14
0.8	16	3/8	16V ER 0.8 ISO	16V EL 0.8 ISO			.04	.02	.14
1.0	16	3/8	16V ER 1.0 ISO	16V EL 1.0 ISO			.04	.03	.14
1.25	16	3/8	16V ER 1.25 ISO	16V EL 1.25 ISO			.04	.04	.14
1.5	16	3/8	16V ER 1.5 ISO	16V EL 1.5 ISO			.04	.04	.14
1.75	16	3/8	16V ER 1.75 ISO	16V EL 1.75 ISO			.04	.05	.14
2.0	16	3/8	16V ER 2.0 ISO	16V EL 2.0 ISO			.04	.05	.14
2.5	16	3/8	16V ER 2.5 ISO	16V EL 2.5 ISO			.04	.06	.14
3.0	16	3/8	16V ER 3.0 ISO	16V EL 3.0 ISO			.04	.07	.14
* 8.0	27	5/8	27V ER 8.0 ISO	27V EL 8.0 ISO	27V IR 8.0 ISO	27 IL 8.0 ISO	.07	.20	.41
** 10.0	27	5/8	27V ER 10.0 ISO	27V EL 10.0 ISO	27V IR 10.0 ISO	27 IL 10.0 ISO	.07	.20	.41

Order example: 16V ER 1.5 ISO BMA

* Minimum bore: 2.36"
** Minimum bore: 2.83"

Multitooth

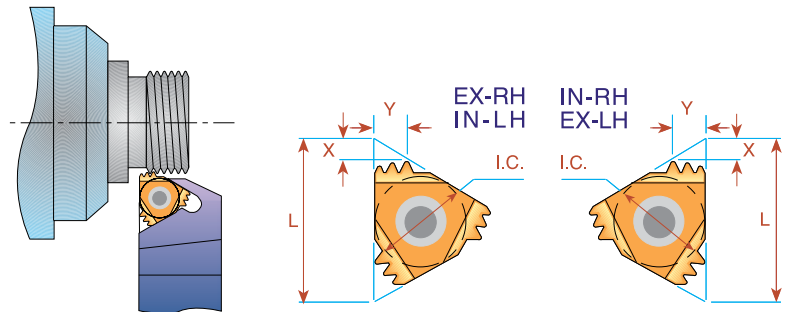

Pitch mm	L mm	I.C.	Number of Teeth	EXTERNAL	Anvil	INTERNAL	Anvil	X	Y
				Ordering Code		Ordering Code			
1.0	16	3/8	3	16 ER 1.0 ISO 3M	AE16M	16 IR 1.0 ISO 3M	AI16M	.07	.10
1.5	16	3/8	2	16 ER 1.5 ISO 2M	AE16M	16 IR 1.5 ISO 2M	AI16M	.06	.09
1.5	22	1/2	3	22 ER 1.5 ISO 3M	AE22M	22 IR 1.5 ISO 3M	AI22M	.09	.15
2.0	22	1/2	2	22 ER 2.0 ISO 2M	AE22M	22 IR 2.0 ISO 2M	AI22M	.08	.12
2.0	22	1/2	3	22 ER 2.0 ISO 3M	AE22M	22 IR 2.0 ISO 3M	AI22M	.12	.20
3.0	27	5/8	2	27 ER 3.0 ISO 2M	AE27M	27 IR 3.0 ISO 2M	AI27M	.11	.18

Order example: 22 IR B 2.0 ISO 2M BMA

For recommended number of passes see page 68

For Carbide Grade and Cutting Speed see page 66-67

UN - Unified UNC, UNF, UNEF, UNS

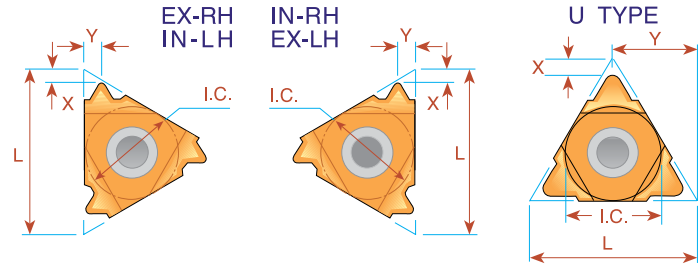
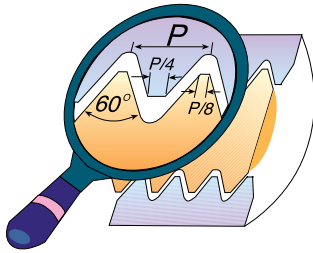

Pitch TPI	L mm	I.C.	EXTERNAL				INTERNAL			
			Ordering Code		X	Y	Ordering Code		X	Y
Right Hand	Left Hand	Right Hand	Left Hand	Right Hand			Left Hand			
32	6	5/32	<i>ULTRA MINIATURE</i> →			*06 IR 32 UN	*06 IL 32 UN	.03	.02	
28	6	5/32				*06 IR 28 UN	*06 IL 28 UN	.03	.02	
24	6	5/32				*06 IR 24 UN	*06 IL 24 UN	.03	.02	
20	6	5/32				*06 IR 20 UN	*06 IL 20 UN	.02	.02	
18	6	5/32				*06 IR 18 UN	*06 IL 18 UN	.02	.03	
32	8	3/16	<i>MINIATURE</i> →			*08 IR 32 UN	*08 IL 32 UN	.02	.02	
28	8	3/16				*08 IR 28 UN	*08 IL 28 UN	.02	.02	
24	8	3/16				*08 IR 24 UN	*08 IL 24 UN	.02	.02	
20	8	3/16				*08 IR 20 UN	*08 IL 20 UN	.02	.03	
18	8	3/16				*08 IR 18 UN	*08 IL 18 UN	.02	.03	
16	8	3/16				*08 IR 16 UN	*08 IL 16 UN	.02	.03	
14	8	3/16			*08 IR 14 UN	*08 IL 14 UN	.02	.03		
13	8	3/16			**08 IR 13 UN		.03	.04		
13	8U	3/16U	<i>"U" MINIATURE</i> →			*08U IR/L 13 UN		.04	.16	
12	8U	3/16U				*08U IR/L 12 UN		.04	.16	
11	8U	3/16U				*08U IR/L 11 UN		.04	.16	
72	11	1/4	11 ER 72 UN	11 EL 72 UN	.03	.02	11 IR 72 UN	11 IL 72 UN	.03	.01
64	11	1/4	11 ER 64 UN	11 EL 64 UN	.03	.02	11 IR 64 UN	11 IL 64 UN	.03	.02
56	11	1/4	11 ER 56 UN	11 EL 56 UN	.03	.02	11 IR 56 UN	11 IL 56 UN	.03	.02
48	11	1/4	11 ER 48 UN	11 EL 48 UN	.02	.02	11 IR 48 UN	11 IL 48 UN	.02	.02
44	11	1/4	11 ER 44 UN	11 EL 44 UN	.02	.02	11 IR 44 UN	11 IL 44 UN	.02	.02
40	11	1/4	11 ER 40 UN	11 EL 40 UN	.02	.02	11 IR 40 UN	11 IL 40 UN	.02	.02
36	11	1/4	11 ER 36 UN	11 EL 36 UN	.02	.02	11 IR 36 UN	11 IL 36 UN	.02	.02
32	11	1/4	11 ER 32 UN	11 EL 32 UN	.02	.02	11 IR 32 UN	11 IL 32 UN	.02	.02
28	11	1/4	11 ER 28 UN	11 EL 28 UN	.02	.03	11 IR 28 UN	11 IL 28 UN	.02	.03
27	11	1/4	11 ER 27 UN	11 EL 27 UN	.03	.03	11 IR 27 UN	11 IL 27 UN	.03	.03
24	11	1/4	11 ER 24 UN	11 EL 24 UN	.03	.03	11 IR 24 UN	11 IL 24 UN	.03	.03
20	11	1/4	11 ER 20 UN	11 EL 20 UN	.03	.04	11 IR 20 UN	11 IL 20 UN	.03	.04
18	11	1/4	11 ER 18 UN	11 EL 18 UN	.03	.04	11 IR 18 UN	11 IL 18 UN	.03	.04
16	11	1/4	11 ER 16 UN	11 EL 16 UN	.04	.04	11 IR 16 UN	11 IL 16 UN	.04	.04
14	11	1/4	11 ER 14 UN	11 EL 14 UN	.04	.04	11 IR 14 UN	11 IL 14 UN	.04	.04
13	11	1/4					11 IR 13 UN	11 IL 13 UN	.03	.04
12	11	1/4					11 IR 12 UN	11 IL 12 UN	.04	.04
11	11	1/4					11 IR 11 UN	11 IL 11 UN	.03	.04
72	16	3/8	16 ER 72 UN	16 EL 72 UN	.03	.02	16 IR 72 UN	16 IL 72 UN	.03	.01
64	16	3/8	16 ER 64 UN	16 EL 64 UN	.03	.02	16 IR 64 UN	16 IL 64 UN	.03	.02
56	16	3/8	16 ER 56 UN	16 EL 56 UN	.03	.02	16 IR 56 UN	16 IL 56 UN	.03	.02
48	16	3/8	16 ER 48 UN	16 EL 48 UN	.02	.02	16 IR 48 UN	16 IL 48 UN	.02	.02
44	16	3/8	16 ER 44 UN	16 EL 44 UN	.02	.02	16 IR 44 UN	16 IL 44 UN	.02	.02
40	16	3/8	16 ER 40 UN	16 EL 40 UN	.02	.02	16 IR 40 UN	16 IL 40 UN	.02	.02
36	16	3/8	16 ER 36 UN	16 EL 36 UN	.02	.02	16 IR 36 UN	16 IL 36 UN	.02	.02

* Available only in BXC and BMA grades

** To be used with Holder SIR 0354 K08 on page 52

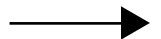

Thread Turning Inserts

UN - Unified **UNC, UNF, UNEF, UNS**

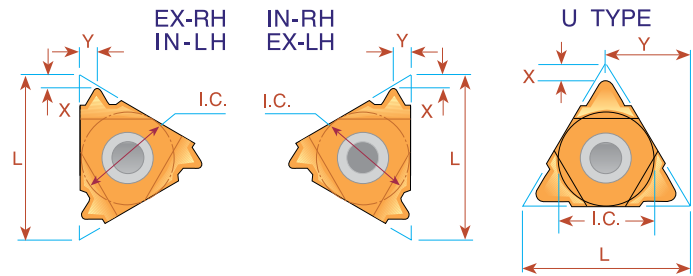
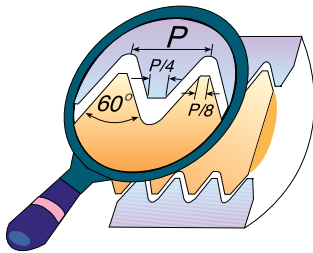

Pitch TPI	L mm	I.C.	EXTERNAL				INTERNAL			
			Ordering Code		X	Y	Ordering Code		X	Y
			Right Hand	Left Hand			Right Hand	Left Hand		
32	16	3/8	16 ER 32 UN	16 EL 32 UN	.02	.02	16 IR 32 UN	16 IL 32 UN	.02	.02
28	16	3/8	16 ER 28 UN	16 EL 28 UN	.02	.03	16 IR 28 UN	16 IL 28 UN	.02	.03
27	16	3/8	16 ER 27 UN	16 EL 27 UN	.03	.03	16 IR 27 UN	16 IL 27 UN	.03	.03
24	16	3/8	16 ER 24 UN	16 EL 24 UN	.03	.03	16 IR 24 UN	16 IL 24 UN	.03	.03
20	16	3/8	16 ER 20 UN	16 EL 20 UN	.03	.04	16 IR 20 UN	16 IL 20 UN	.03	.04
18	16	3/8	16 ER 18 UN	16 EL 18 UN	.03	.04	16 IR 18 UN	16 IL 18 UN	.03	.04
16	16	3/8	16 ER 16 UN	16 EL 16 UN	.04	.04	16 IR 16 UN	16 IL 16 UN	.04	.04
14	16	3/8	16 ER 14 UN	16 EL 14 UN	.04	.05	16 IR 14 UN	16 IL 14 UN	.04	.05
13	16	3/8	16 ER 13 UN	16 EL 13 UN	.04	.05	16 IR 13 UN	16 IL 13 UN	.04	.05
12	16	3/8	16 ER 12 UN	16 EL 12 UN	.04	.06	16 IR 12 UN	16 IL 12 UN	.04	.06
11.5	16	3/8	16 ER 11.5 UN	16 EL 11.5 UN	.04	.06	16 IR 11.5 UN	16 IL 11.5 UN	.04	.06
11	16	3/8	16 ER 11 UN	16 EL 11 UN	.04	.06	16 IR 11 UN	16 IL 11 UN	.04	.06
10	16	3/8	16 ER 10 UN	16 EL 10 UN	.04	.06	16 IR 10 UN	16 IL 10 UN	.04	.06
9	16	3/8	16 ER 9 UN	16 EL 9 UN	.05	.07	16 IR 9 UN	16 IL 9 UN	.05	.07
8	16	3/8	16 ER 8 UN	16 EL 8 UN	.05	.06	16 IR 8 UN	16 IL 8 UN	.04	.06
7	22	1/2	22 ER 7 UN	22 EL 7 UN	.06	.09	22 IR 7 UN	22 IL 7 UN	.06	.09
6	22	1/2	22 ER 6 UN	22 EL 6 UN	.06	.09	22 IR 6 UN	22 IL 6 UN	.06	.09
5	22	1/2	22 ER 5 UN	22 EL 5 UN	.07	.10	22 IR 5 UN	22 IL 5 UN	.06	.09
4.5	22U	1/2U	22U ER/L 4.5 UN		.08	.43	22U IR/L 4.5 UN		.09	.43
4	22U	1/2U	22U ER/L 4 UN		.08	.43	22U IR/L 4 UN		.09	.43
4.5	27	5/8	27 ER 4.5 UN	27 EL 4.5 UN	.07	.11	27 IR 4.5 UN	27 IL 4.5 UN	.07	.09
4	27	5/8	27 ER 4 UN	27 EL 4 UN	.08	.12	27 IR 4 UN	27 IL 4 UN	.07	.11
3	27U	5/8U	27U ER/L 3 UN		.10	.54	27U IR/L 3 UN		.11	.54
2	33U	3/4U	33U ER/L 2 UN		.11	.65	33U IR/L 2 UN		.14	.67

Order example: 22ER 7 UN BMA

For small bore threading see page 89

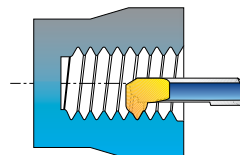

For Carbide Grade and Cutting Speed see page 66-67

UN - Unified Vertical

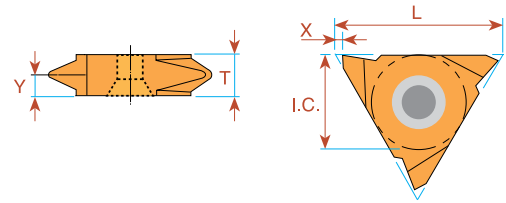

Pitch TPI	L mm	I.C.	EXTERNAL		INTERNAL		X	Y	T
			Ordering Code Right Hand	Ordering Code Left Hand	Ordering Code Right Hand	Ordering Code Left Hand			
32	16	3/8	16V ER 32 UN	16V EL 32 UN			.04	.02	.14
28	16	3/8	16V ER 28 UN	16V EL 28 UN			.04	.03	.14
24	16	3/8	16V ER 24 UN	16V EL 24 UN			.04	.03	.14
20	16	3/8	16V ER 20 UN	16V EL 20 UN			.04	.03	.14
18	16	3/8	16V ER 18 UN	16V EL 18 UN			.04	.04	.14
16	16	3/8	16V ER 16 UN	16V EL 16 UN			.04	.04	.14
14	16	3/8	16V ER 14 UN	16V EL 14 UN			.04	.05	.14
12	16	3/8	16V ER 12 UN	16V EL 12 UN			.04	.05	.14
10	16	3/8	16V ER 10 UN	16V EL 10 UN			.04	.06	.14
8	16	3/8	16V ER 8 UN	16V EL 8 UN			.04	.06	.14
7	22	1/2	22V ER 7 UN	22V EL 7 UN			.05	.09	.19
* 3	27	5/8	27V ER 3 UN	27V EL 3 UN	27V IR 3 UN	27 IL 3 UN	.07	.20	.41

Order example: 22V ER 7UN MXC

* Minimum bore: Ø2.56"

UN - Unified Type B **UNC, UNF, UNEF, UNS**

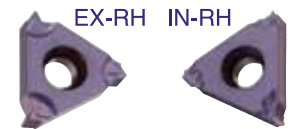

Ground Profile with Sintered Chip-breaker

Pitch TPI	L	I.C. in	EXTERNAL		X	Y	INTERNAL		X	Y
			Ordering Code Right Hand	Ordering Code Right Hand			Ordering Code Right Hand	Ordering Code Right Hand		
32	11	1/4					11 IR B 32 UN		.02	.02
28	11	1/4					11 IR B 28 UN		.02	.02
24	11	1/4					11 IR B 24 UN		.02	.02
20	11	1/4					11 IR B 20 UN		.03	.04
18	11	1/4					11 IR B 18 UN		.03	.04
16	11	1/4					11 IR B 16 UN		.03	.04
14	11	1/4					11 IR B 14 UN		.03	.04
12	11	1/4					11 IR B 12 UN		.03	.04
24	16	3/8	16 ER B 24 UN		.03	.03	16 IR B 24 UN		.03	.03
20	16	3/8	16 ER B 20 UN		.03	.04	16 IR B 20 UN		.03	.03
18	16	3/8	16 ER B 18 UN		.03	.04	16 IR B 18 UN		.03	.03
16	16	3/8	16 ER B 16 UN		.04	.04	16 IR B 16 UN		.04	.04
14	16	3/8	16 ER B 14 UN		.04	.05	16 IR B 14 UN		.04	.05
13	16	3/8	16 ER B 13 UN		.04	.05				
12	16	3/8	16 ER B 12 UN		.04	.06	16 IR B 12 UN		.04	.06
11	16	3/8	16 ER B 11 UN		.04	.06				
10	16	3/8	16 ER B 10 UN		.04	.06	16 IR B 10 UN		.04	.06
9	16	3/8	16 ER B 9 UN		.05	.07				
8	16	3/8	16 ER B 8 UN		.05	.06	16 IR B 8 UN		.04	.06

Order example: 16 IR B 12 UN BMA

Multitooth

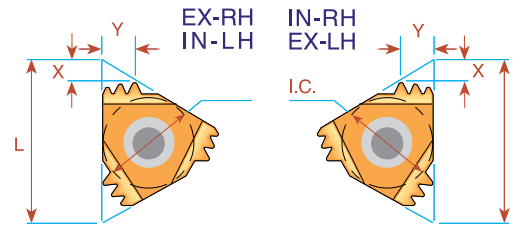
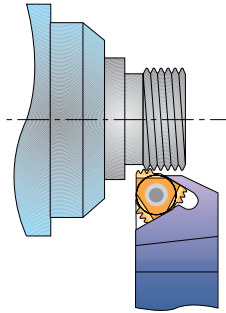

Pitch TPI	L	I.C. in	Number of Teeth	EXTERNAL		INTERNAL		X	Y
				Ordering Code	Anvil	Ordering Code	Anvil		
24	16	3/8	2	16 ER 24 UN 2M	AE16M	16 IR 24 UN 2M	AI16M	.04	.07
20	16	3/8	2	16 ER 20 UN 2M	AE16M	16 IR 20 UN 2M	AI16M	.06	.08
18	16	3/8	2	16 ER 18 UN 2M	AE16M	16 IR 18 UN 2M	AI16M	.06	.09
16	16	3/8	2	16 ER 16 UN 2M	AE16M	16 IR 16 UN 2M	AI16M	.06	.09
14	16	3/8	2	16 ER 14 UN 2M	AE16M	16 IR 14 UN 2M	AI16M	.07	.11
12	16	3/8	2	16 ER 12 UN 2M	AE16M	16 IR 12 UN 2M	AI16M	.08	.12
16	22	1/2	3	22 ER 16 UN 3M	AE22M	22 IR 16 UN 3M	AI22M	.10	.16
13	22	1/2	3	22 ER 13 UN 3M	AE22M	-	AI22M	.12	.19
12	22	1/2	2	22 ER 12 UN 2M	AE22M	22 IR 12 UN 2M	AI22M	.09	.13
12	22	1/2	3	22 ER 12 UN 3M	AE22M	22 IR 12 UN 3M	AI22M	.13	.21
8	27	5/8	2	27 ER 8 UN 2M	AE27M	27 IR 8 UN 2M	AI27M	.12	.19

Order example: 22 IR 16 UN 3M BMA

For recommended number of passes see page 68

For Carbide Grade and Cutting Speed see page 66-67

Whitworth - 55° BSW, BSF, BSP, BSB

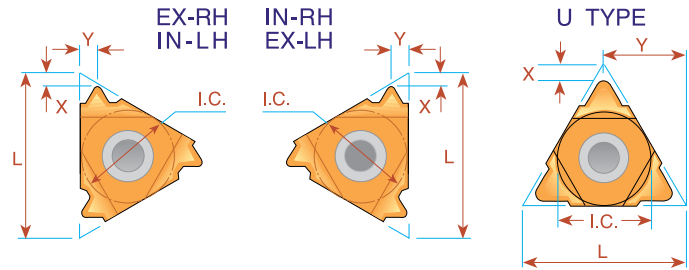
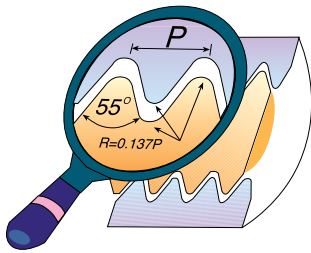

Pitch TPI	L mm	I.C.	EXTERNAL		INTERNAL		X	Y
			Ordering Code Right Hand	Ordering Code Left Hand	Ordering Code Right Hand	Ordering Code Left Hand		
26	6	5/32	<i>ULTRA MINIATURE</i> →		*06 IR 26 W	*06 IL 26 W	.03	.02
22	6	5/32			*06 IR 22 W	*06 IL 22 W	.02	.02
20	6	5/32			*06 IR 20 W	*06 IL 20 W	.02	.03
18	6	5/32			*06 IR 18 W	*06 IL 18 W	.02	.03
28	8	3/16	<i>MINIATURE</i> →		*08 IR 28 W	*08 IL 28 W	.02	.02
24	8	3/16			*08 IR 24 W	*08 IL 24 W	.02	.02
20	8	3/16			*08 IR 20 W	*08 IL 20 W	.02	.03
19	8	3/16			*08 IR 19 W	*08 IL 19 W	.02	.03
18	8	3/16			*08 IR 18 W	*08 IL 18 W	.02	.03
16	8	3/16			*08 IR 16 W	*08 IL 16 W	.02	.03
14	8U	3/16U	<i>"U" MINIATURE</i> →		*08U IR/L 14 W		.04	.16
12	8U	3/16U			*08U IR/L 12 W		.04	.16
11	8U	3/16U			*08U IR/L 11 W		.04	.16
72	11	1/4	11 ER 72 W	11 EL 72 W	11 IR 72 W	11 IL 72 W	.03	.02
60	11	1/4	11 ER 60 W	11 EL 60 W	11 IR 60 W	11 IL 60 W	.03	.02
56	11	1/4	11 ER 56 W	11 EL 56 W	11 IR 56 W	11 IL 56 W	.03	.02
48	11	1/4	11 ER 48 W	11 EL 48 W	11 IR 48 W	11 IL 48 W	.02	.02
40	11	1/4	11 ER 40 W	11 EL 40 W	11 IR 40 W	11 IL 40 W	.02	.02
36	11	1/4	11 ER 36 W	11 EL 36 W	11 IR 36 W	11 IL 36 W	.02	.02
32	11	1/4	11 ER 32 W	11 EL 32 W	11 IR 32 W	11 IL 32 W	.02	.02
28	11	1/4	11 ER 28 W	11 EL 28 W	11 IR 28 W	11 IL 28 W	.02	.03
26	11	1/4	11 ER 26 W	11 EL 26 W	11 IR 26 W	11 IL 26 W	.03	.03
24	11	1/4	11 ER 24 W	11 EL 24 W	11 IR 24 W	11 IL 24 W	.03	.03
22	11	1/4	11 ER 22 W	11 EL 22 W	11 IR 22 W	11 IL 22 W	.03	.04
20	11	1/4	11 ER 20 W	11 EL 20 W	11 IR 20 W	11 IL 20 W	.03	.04
19	11	1/4	11 ER 19 W	11 EL 19 W	11 IR 19 W	11 IL 19 W	.03	.04
18	11	1/4	11 ER 18 W	11 EL 18 W	11 IR 18 W	11 IL 18 W	.03	.04
16	11	1/4	11 ER 16 W	11 EL 16 W	11 IR 16 W	11 IL 16 W	.04	.04
14	11	1/4	11 ER 14 W	11 EL 14 W	11 IR 14 W	11 IL 14 W	.04	.04
12	11	1/4			11 IR 12 W	11 IL 12 W	.04	.04
11	11	1/4			(1) 11 IR 11 W	(1) 11 IL 11 W	.04	.05
72	16	3/8	16 ER 72 W	16 EL 72 W	16 IR 72 W	16 IL 72 W	.03	.02
60	16	3/8	16 ER 60 W	16 EL 60 W	16 IR 60 W	16 IL 60 W	.03	.02
56	16	3/8	16 ER 56 W	16 EL 56 W	16 IR 56 W	16 IL 56 W	.03	.02
48	16	3/8	16 ER 48 W	16 EL 48 W	16 IR 48 W	16 IL 48 W	.02	.02
40	16	3/8	16 ER 40 W	16 EL 40 W	16 IR 40 W	16 IL 40 W	.02	.02
36	16	3/8	16 ER 36 W	16 EL 36 W	16 IR 36 W	16 IL 36 W	.02	.02
32	16	3/8	16 ER 32 W	16 EL 32 W	16 IR 32 W	16 IL 32 W	.02	.02
28	16	3/8	16 ER 28 W	16 EL 28 W	16 IR 28 W	16 IL 28 W	.02	.03
26	16	3/8	16 ER 26 W	16 EL 26 W	16 IR 26 W	16 IL 26 W	.03	.03
24	16	3/8	16 ER 24 W	16 EL 24 W	16 IR 24 W	16 IL 24 W	.03	.03

* Available only in BXC and BMA grades

(1) Special holder is required or standard holder can be amended by customer.

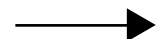

Whitworth - 55° BSW, BSF, BSP, BSB

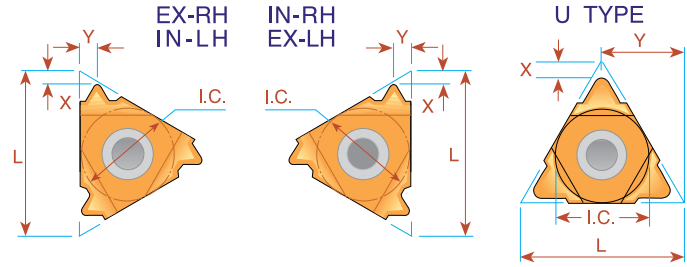
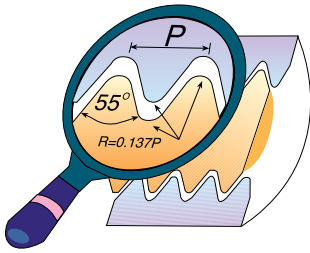

Pitch TPI	L mm	I.C.	EXTERNAL		INTERNAL		X	Y
			Ordering Code		Ordering Code			
			Right Hand	Left Hand	Right Hand	Left Hand		
22	16	3/8	16 ER 22 W	16 EL 22 W	16 IR 22 W	16 IL 22 W	.03	.04
20	16	3/8	16 ER 20 W	16 EL 20 W	16 IR 20 W	16 IL 20 W	.03	.04
19	16	3/8	16 ER 19 W	16 EL 19 W	16 IR 19 W	16 IL 19 W	.03	.04
18	16	3/8	16 ER 18 W	16 EL 18 W	16 IR 18 W	16 IL 18 W	.03	.04
16	16	3/8	16 ER 16 W	16 EL 16 W	16 IR 16 W	16 IL 16 W	.04	.04
14	16	3/8	16 ER 14 W	16 EL 14 W	16 IR 14 W	16 IL 14 W	.04	.05
12	16	3/8	16 ER 12 W	16 EL 12 W	16 IR 12 W	16 IL 12 W	.04	.06
11	16	3/8	16 ER 11 W	16 EL 11 W	16 IR 11 W	16 IL 11 W	.04	.06
10	16	3/8	16 ER 10 W	16 EL 10 W	16 IR 10 W	16 IL 10 W	.04	.06
9	16	3/8	16 ER 9 W	16 EL 9 W	16 IR 9 W	16 IL 9 W	.05	.07
8	16	3/8	16 ER 8 W	16 EL 8 W	16 IR 8 W	16 IL 8 W	.05	.06
7	22	1/2	22 ER 7 W	22 EL 7 W	22 IR 7 W	22 IL 7 W	.06	.09
6	22	1/2	22 ER 6 W	22 EL 6 W	22 IR 6 W	22 IL 6 W	.06	.09
5	22	1/2	22 ER 5 W	22 EL 5 W	22 IR 5 W	22 IL 5 W	.07	.09
4.5	22U	1/2U	22U E/R/L 4.5 W				.09	.43
4	22U	1/2U	22U E/R/L 4 W				.07	.43
4.5	27	5/8	27 ER 4.5 W	27 EL 4.5 W	27 IR 4.5 W	27 IL 4.5 W	.07	.10
4	27	5/8	27 ER 4 W	27 EL 4 W	27 IR 4 W	27 IL 4 W	.08	.11
3.5	27U	5/8U	27U E/R/L 3.5 W				.08	.54
3.25	27U	5/8U	27U E/R/L 3.25 W				.08	.54
3	27U	5/8U	27U E/R/L 3 W				.09	.54
2.75	27U	5/8U	27U E/R/L 2.75 W				.09	.54

Order example: 16 IR 18 W BMA

For Carbide Grade and Cutting Speed see page 66-67

Whitworth - 55° BSW, BSF, BSP, BSB

Type B

Ground Profile with Sintered Chip-breaker

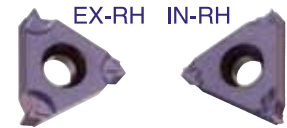

Pitch TPI	L	I.C. in	EXTERNAL	INTERNAL	X	Y
			Ordering Code Right Hand	Ordering Code Right Hand		
28	11	1/4		11 IR B 28 W	.02	.02
24	11	1/4		11 IR B 24 W	.02	.02
20	11	1/4		11 IR B 20 W	.03	.04
19	11	1/4		11 IR B 19 W	.03	.04
18	11	1/4		11 IR B 18 W	.03	.04
16	11	1/4		11 IR B 16 W	.03	.04
14	11	1/4		11 IR B 14 W	.03	.04
19	16	3/8	16 ER B 19 W	16 IR B 19 W	.03	.04
16	16	3/8	16 ER B 16 W	16 IR B 16 W	.04	.04
14	16	3/8	16 ER B 14 W	16 IR B 14 W	.04	.05
11	16	3/8	16 ER B 11 W	16 IR B 11 W	.04	.06
10	16	3/8	16 ER B 10 W	16 IR B 10 W	.04	.06

Order example: 16 IR B 10 W BMA

Vertical

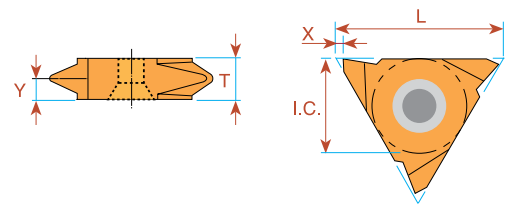

Pitch TPI	L mm	I.C.	EXTERNAL	EXTERNAL	X	Y	T
			Ordering Code Right Hand	Ordering Code Left Hand			
20	16	3/8	16V ER 20 W	16V EL 20 W	.04	.04	.14
19	16	3/8	16V ER 19 W	16V EL 19 W	.04	.04	.14
18	16	3/8	16V ER 18 W	16V EL 18 W	.04	.04	.14
16	16	3/8	16V ER 16 W	16V EL 16 W	.04	.04	.14
14	16	3/8	16V ER 14 W	16V EL 14 W	.04	.05	.14
12	16	3/8	16V ER 12 W	16V EL 12 W	.04	.05	.14
11	16	3/8	16V ER 11 W	16V EL 11 W	.04	.06	.14

Order example: 16V ER 14 W MXC

Multitooth

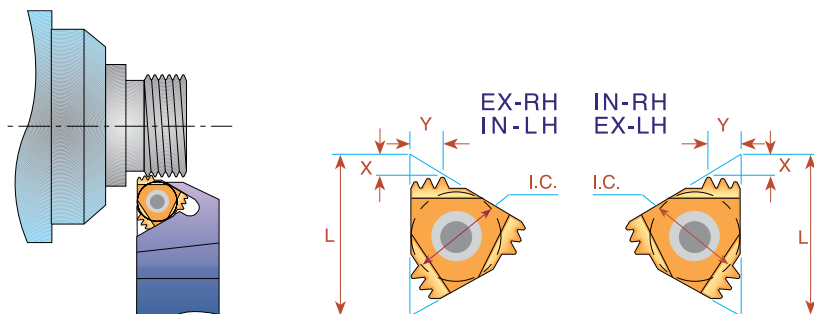

Pitch TPI	L mm	I.C.	Number of Teeth	EXTERNAL Ordering Code	Anvil	INTERNAL Ordering Code	Anvil	X	Y
14	16	3/8	2	16 ER 14 W 2M	AE16M	16 IR 14 W 2M	AI16M	.07	.11
14	22	1/2	3	22 ER 14 W 3M	AE22M	22 IR 14 W 3M	AI22M	.11	.18
11	22	1/2	2	22 ER 11 W 2M	AE22M	22 IR 11 W 2M	AI22M	.09	.13

Order example: 16 ER 14 W 2M MXC

For recommended number of passes see page 68

For Carbide Grade and Cutting Speed see page 66-67

NPT

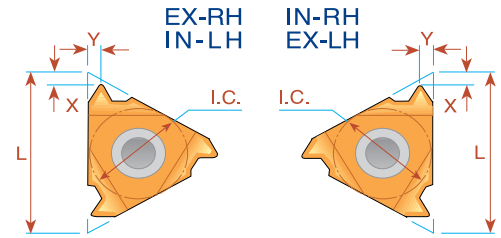
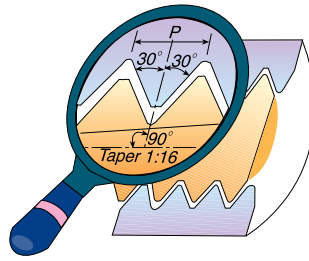

Pitch TPI	L mm	I.C.	EXTERNAL		INTERNAL		X	Y
			Ordering Code		Ordering Code			
			Right Hand	Left Hand	Right Hand	Left Hand		
27	6	5/32	<i>ULTRA MINIATURE</i> →		*06 IR 27 NPT	*06 IL 27 NPT	.02	.02
27	8	3/16			*08 IR 27 NPT	*08 IL 27 NPT	.02	.02
18	8	3/16	<i>MINIATURE</i> →		*08 IR 18 NPT	*08 IL 18 NPT	.02	.02
27	11	1/4	11 ER 27 NPT	11 EL 27 NPT	11 IR 27 NPT	11 IL 27 NPT	.03	.03
18	11	1/4	11 ER 18 NPT	11 EL 18 NPT	11 IR 18 NPT	11 IL 18 NPT	.03	.04
14	11	1/4	11 ER 14 NPT	11 EL 14 NPT	11 IR 14 NPT	11 IL 14 NPT	.03	.04
27	16	3/8	16 ER 27 NPT	16 EL 27 NPT	16 IR 27 NPT	16 IL 27 NPT	.03	.03
18	16	3/8	16 ER 18 NPT	16 EL 18 NPT	16 IR 18 NPT	16 IL 18 NPT	.03	.04
14	16	3/8	16 ER 14 NPT	16 EL 14 NPT	16 IR 14 NPT	16 IL 14 NPT	.04	.05
11.5	16	3/8	16 ER 11.5 NPT	16 EL 11.5 NPT	16 IR 11.5 NPT	16 IL 11.5 NPT	.04	.06
8	16	3/8	16 ER 8 NPT	16 EL 8 NPT	16 IR 8 NPT	16 IL 8 NPT	.05	.07

Order example: 16 ER 14 NPT MXC

* Available only in BXC and BMA grades

Type B

Ground Profile with Sintered Chip-breaker

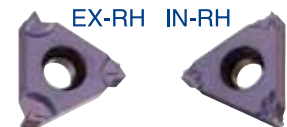

Pitch TPI	L	I.C. in	EXTERNAL		INTERNAL		X	Y
			Ordering Code Right Hand		Ordering Code Right Hand			
18	11	1/4			11 IR B 18 NPT		.03	.04
18	16	3/8	16 ER B 18 NPT		16 IR B 18 NPT		.03	.04
14	16	3/8	16 ER B 14 NPT		16 IR B 14 NPT		.04	.05
11.5	16	3/8	16 ER B 11.5 NPT		16 IR B 11.5 NPT		.04	.06
8	16	3/8	16 ER B 8 NPT		16 IR B 8 NPT		.05	.07

Order example: 16 IR B 11.5 NPT BMA

For Carbide Grade and Cutting Speed see page 66-67

NPT Multitooth

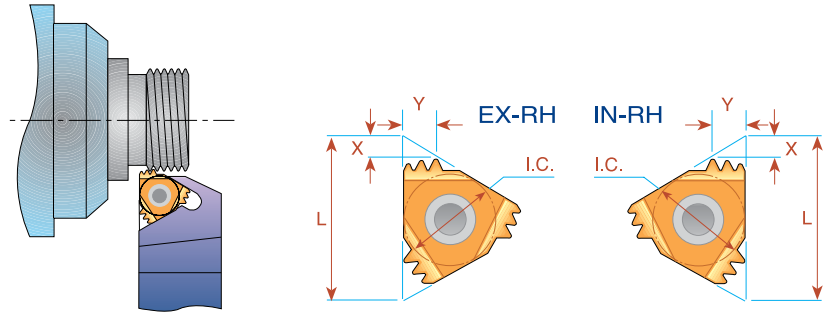

Pitch TPI	L mm	I.C.	Number of Teeth	EXTERNAL Ordering Code	Anvil	INTERNAL Ordering Code	Anvil	X	Y
14	16	3/8	2	16 ER 14 NPT 2M	AE16M	16 IR 14 NPT 2M	AI16M	.07	.11
11.5	22	1/2	2	22 ER 11.5 NPT 2M	AE22M	22 IR 11.5 NPT 2M	AI22M	.09	.14
11.5	27	5/8	3	27 ER 11.5 NPT 3M	AE27M	27 IR 11.5 NPT 3M	AI27M	.13	.22
8	27	5/8	2	27 ER 8 NPT 2M	AE27M	27 IR 8 NPT 2M	AI27M	.12	.20

Order example: 22 ER 11.5 NPT 2M MXC

For recommended number of passes see page 68

NPT Vertical

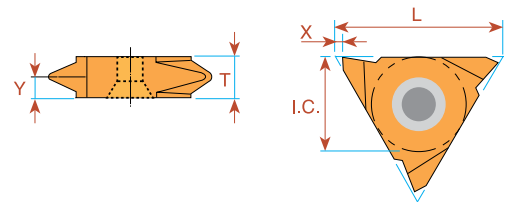

Pitch TPI	L mm	I.C.	EXTERNAL Ordering Code Right Hand	EXTERNAL Ordering Code Left Hand	X	Y	T
27	16	3/8	16V ER 27 NPT	16V EL 27 NPT	.04	.03	.14
18	16	3/8	16V ER 18 NPT	16V EL 18 NPT	.04	.04	.14
14	16	3/8	16V ER 14 NPT	16V EL 14 NPT	.04	.05	.14
11.5	16	3/8	16V ER 11.5 NPT	16V EL 11.5 NPT	.04	.06	.14

Order example: 16V ER 14 NPT BMA

For Carbide Grade and Cutting Speed see page 66-67

NPTF - Dryseal

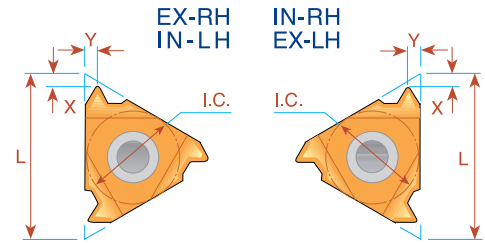
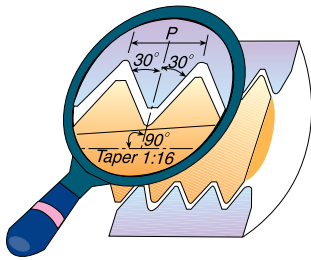

Pitch TPI	L mm	I.C.	EXTERNAL		INTERNAL		X	Y
			Ordering Code		Ordering Code			
			Right Hand	Left Hand	Right Hand	Left Hand		
27	6	5/32	ULTRA MINIATURE →		*06 IR 27 NPTF	*06 IL 27 NPTF	.03	.02
27	8	3/16			*08 IR 27 NPTF	*08 IL 27 NPTF	.02	.02
18	8	3/16	MINIATURE →		*08 IR 18 NPTF	*08 IL 18 NPTF	.02	.02
27	11	1/4	11 ER 27 NPTF	11 EL 27 NPTF	11 IR 27 NPTF	11 IL 27 NPTF	.03	.03
18	11	1/4	11 ER 18 NPTF	11 EL 18 NPTF	11 IR 18 NPTF	11 IL 18 NPTF	.03	.04
14	11	1/4	11 ER 14 NPTF	11 EL 14 NPTF	11 IR 14 NPTF	11 IL 14 NPTF	.03	.04
27	16	3/8	16 ER 27 NPTF	16 EL 27 NPTF	16 IR 27 NPTF	16 IL 27 NPTF	.03	.03
18	16	3/8	16 ER 18 NPTF	16 EL 18 NPTF	16 IR 18 NPTF	16 IL 18 NPTF	.03	.04
14	16	3/8	16 ER 14 NPTF	16 EL 14 NPTF	16 IR 14 NPTF	16 IL 14 NPTF	.04	.05
11.5	16	3/8	16 ER 11.5 NPTF	16 EL 11.5 NPTF	16 IR 11.5 NPTF	16 IL 11.5 NPTF	.04	.06
8	16	3/8	16 ER 8 NPTF	16 EL 8 NPTF	16 IR 8 NPTF	16 IL 8 NPTF	.05	.07

Order example: 11 ER 27 NPTF MXC

* Available only in BXC and BMA grades

Type B

Ground Profile with Sintered Chip-breaker

Pitch TPI	L	I.C. in	INTERNAL Ordering Code Right Hand	X	Y
18	11	1/4	11 IR B 18 NPTF	.03	.04



For Carbide Grade and Cutting Speed see page 66-67

Multitooth

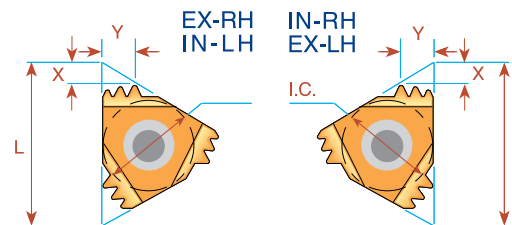
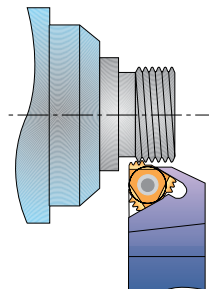

Pitch TPI	L	I.C. in	Number of Teeth	EXTERNAL Ordering Code	Anvil	INTERNAL Ordering Code	Anvil	X	Y
11.5	22	1/2	2	22 ER 11.5 NPTF 2M	AE22M	22 IR 11.5 NPTF 2M	AI22M	.09	0.14

For Carbide Grade and Cutting Speed see page 66-67

BSPT

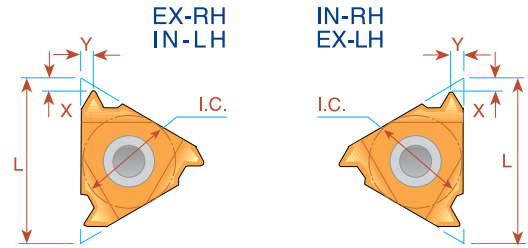
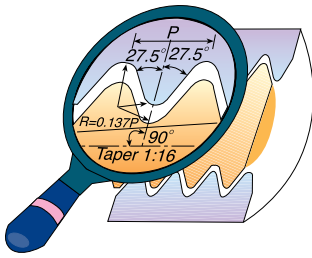

Pitch TPI	L mm	I.C.	EXTERNAL		INTERNAL		X	Y
			Ordering Code Right Hand	Ordering Code Left Hand	Ordering Code Right Hand	Ordering Code Left Hand		
28	6	5/32	ULTRA MINIATURE →		*06 IR 28 BSPT	*06 IL 28 BSPT	.03	.02
28	8	3/16			*08 IR 28 BSPT	*08 IL 28 BSPT	.02	.02
19	8	3/16	MINIATURE →		*08 IR 19 BSPT	*08 IL 19 BSPT	.02	.02
28	11	1/4			11 IR 28 BSPT	11 IL 28 BSPT	.02	.02
19	11	1/4			11 IR 19 BSPT	11 IL 19 BSPT	.03	.04
14	11	1/4			11 IR 14 BSPT	11 IL 14 BSPT	.04	.04
11	11	1/4			⁽¹⁾ 11 IR 11 BSPT	⁽¹⁾ 11 IL 11 BSPT	.04	.05
28	16	3/8	16 ER 28 BSPT	16 EL 28 BSPT	16 IR 28 BSPT	16 IL 28 BSPT	.02	.03
19	16	3/8	16 ER 19 BSPT	16 EL 19 BSPT	16 IR 19 BSPT	16 IL 19 BSPT	.03	.04
14	16	3/8	16 ER 14 BSPT	16 EL 14 BSPT	16 IR 14 BSPT	16 IL 14 BSPT	.04	.05
11	16	3/8	16 ER 11 BSPT	16 EL 11 BSPT	16 IR 11 BSPT	16 IL 11 BSPT	.04	.06

Order example: 11 IR 14 BSPT BMA

* Available only in BXC and BMA grades

(1) Special holder is required or standard holder can be amended by customer.

Type B

Ground Profile with Sintered Chip-breaker

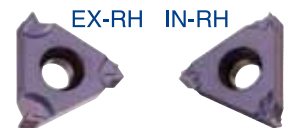

Pitch TPI	L mm	I.C.	EXTERNAL		INTERNAL		X	Y
			Ordering Code Right Hand	Ordering Code Right Hand	Ordering Code Right Hand	Ordering Code Right Hand		
19	11	1/4			11 IR B 19 BSPT		.03	.04
19	16	3/8	16 ER B 19 BSPT				.04	.04
14	16	3/8	16 ER B 14 BSPT				.05	.04
11	16	3/8	16 ER B 11 BSPT				.06	.04

Order example: 16 ER B 11BSPT BMA

For Carbide Grade and Cutting Speed see page 66-67

BSPT Vertical

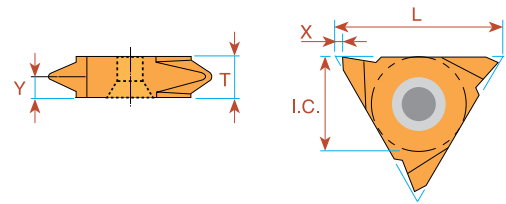

Pitch TPI	L mm	I.C.	EXTERNAL	EXTERNAL	X	Y	T
			Ordering Code Right Hand	Ordering Code Left Hand			
28	16	3/8	16V ER 28 BSPT	16V EL 27 BSPT	.04	.02	.14
19	16	3/8	16V ER 19 BSPT	16V EL 19 BSPT	.04	.04	.14
14	16	3/8	16V ER 14 BSPT	16V EL 14 BSPT	.04	.05	.14
11	16	3/8	16V ER 11 BSPT	16V EL 11 BSPT	.04	.06	.14

Order example: 16V ER 19 BSPT BMA

DIN 477

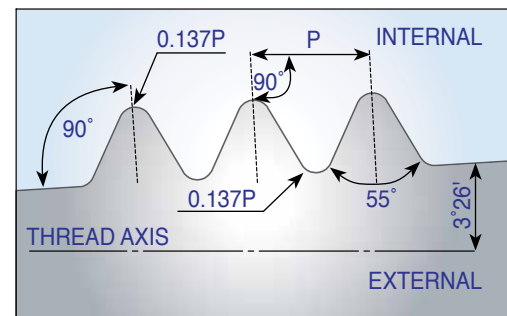

Pitch TPI	L	I.C. in	Taper Ratio	EXTERNAL	INTERNAL	X	Y	Thread Designation
				Ordering Code Right Hand	Ordering Code Right Hand			
14	16	3/8	3/25	16 ER 14 DIN477		.04	.05	W19.8x1/14 keg(Ext.)
14	11	1/4	3/25		*11 IR 14 DIN477	.04	.04	W19.8x1/14 keg(Int.)
14	16	3/8	3/25	16 ER 14 DIN477	**16 IR 14 DIN477	.04	.05	W28.8x1/14 keg
14	16	3/8	3/25	16 ER 14 DIN477	***16 IR 14 DIN477	.04	.05	W31.3x1/14 keg

* Holder to use: SIR0375H11/SIR0375K11

** Holder to use: SIR0625H16

*** Holder to use: SIR0750P16

For Carbide Grade and Cutting Speed see page 66-67

Acme

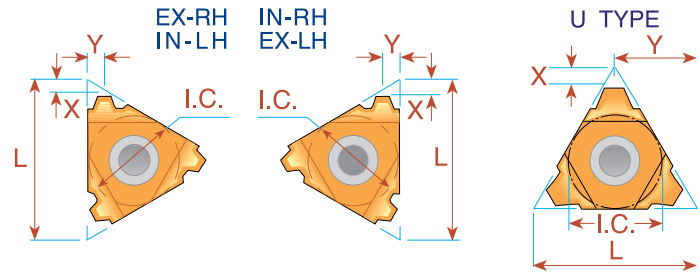
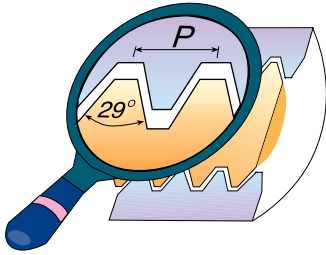

Pitch TPI	L mm	I.C.	EXTERNAL		INTERNAL		X	Y
			Right Hand	Left Hand	Right Hand	Left Hand		
16	8	3/16	MINIATURE		**08 IR 16 ACME	**08 IL 16 ACME	.02	.02
14	8U	3/16U	"U" MINIATURE		*08U IR/L 14 ACME		.03	.16
12	8U	3/16U			*08U IR/L 12 ACME		.03	.16
10	8U	3/16U			*08U IR/L 10 ACME		.03	.16
16	11	1/4	11 ER 16 ACME	11 EL 16 ACME	11 IR 16 ACME	11 IL 16 ACME	.04	.04
16	16	3/8	16 ER 16 ACME	16 EL 16 ACME	16 IR 16 ACME	16 IL 16 ACME	.04	.04
14	16	3/8	16 ER 14 ACME	16 EL 14 ACME	16 IR 14 ACME	16 IL 14 ACME	.04	.05
12	16	3/8	16 ER 12 ACME	16 EL 12 ACME	16 IR 12 ACME	16 IL 12 ACME	.04	.05
10	16	3/8	16 ER 10 ACME	16 EL 10 ACME	16 IR 10 ACME	16 IL 10 ACME	.05	.05
8	16	3/8	16 ER 8 ACME	16 EL 8 ACME	16 IR 8 ACME	16 IL 8 ACME	.06	.05
6	16	3/8	⁽¹⁾ 16 ER 6 ACME	⁽¹⁾ 16 EL 6 ACME	⁽¹⁾ 16 IR 6 ACME	⁽¹⁾ 16 IL 6 ACME	.07	.07
6	22	1/2	22 ER 6 ACME	22 EL 6 ACME	22 IR 6 ACME	22 IL 6 ACME	.07	.08
5	22	1/2	22 ER 5 ACME	22 EL 5 ACME	22 IR 5 ACME	22 IL 5 ACME	.08	.09
4	22	1/2	⁽¹⁾ 22 ER 4 ACME	⁽¹⁾ 22 EL 4 ACME	⁽¹⁾ 22 IR 4 ACME	⁽¹⁾ 22 IL 4 ACME	.08	.09
4	22U	1/2U	22U ER/L 4 ACME		22U IR/L 4 ACME		.09	.43
4	27	5/8	27 ER 4 ACME	27 EL 4 ACME	27 IR 4 ACME	27 IL 4 ACME	.09	.11
3	27U	5/8U	27U ER/L 3 ACME		27U IR/L 3 ACME		.11	.54
2	33U	3/4U	33U ER/L 2 ACME		33U IR/L 2 ACME		.17	.67

Order example: 16 ER 16 ACME MXC

* Available only in BXC and BMA grades

** One cutting edge

(1) Special holder is required or standard holder can be amended by customer.

Acme Vertical

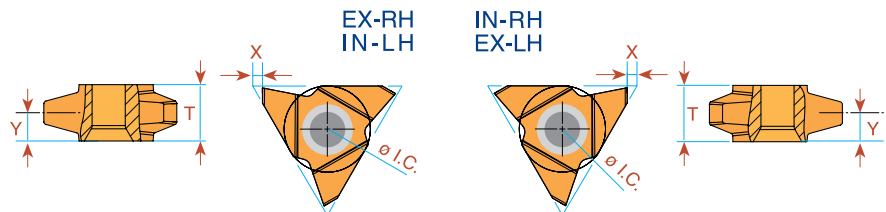

Pitch TPI	L mm	I.C.	EXTERNAL		X	Y	T	INTERNAL		X	Y	T
			Right Hand	Left Hand				Right Hand	Left Hand			
* 3.5	27	5/8	27V ER 3.5 ACME	—	.07	.20	.41	27V IR 3.5 ACME	—	.07	.16	.41
** 3	27	5/8	27V ER 3 ACME	—	.07	.20	.41	27V IR 3 ACME	—	.07	.18	.41
*** 2	27	5/8	27V ER 2 ACME	27V EL 2 ACME	.07	.20	.41	27V IR 2 ACME	27V IL 2 ACME	.07	.20	.41

Order example: 27V ER 2 ACME BMA

* Minimum bore: Ø2.17" ** Minimum bore: Ø2.17" *** Minimum bore: Ø3"

For Carbide Grade and Cutting Speed see page 66-67

Stub Acme

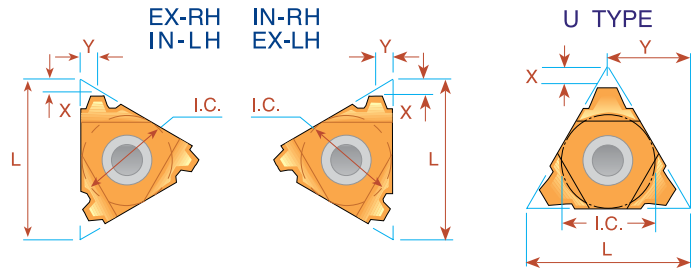
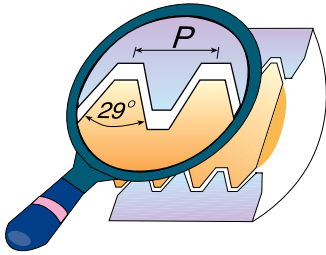

Pitch TPI	L mm	I.C.	EXTERNAL		INTERNAL		X	Y
			Right Hand	Left Hand	Right Hand	Left Hand		
16	8	3/16	<i>MINIATURE</i> →		**08 IR 16 STACME	**08 IL 16 STACME	.02	.02
14	8U	3/16U	<i>"U" MINIATURE</i> →		*08U IR/L 14 STACME		.03	.16
12	8U	3/16U			*08U IR/L 12 STACME		.04	.16
10	8U	3/16U			*08U IR/L 10 STACME		.04	.16
16	11	1/4	11 ER 16 STACME	11 EL 16 STACME			.04	.04
16	16	3/8	16 ER 16 STACME	16 EL 16 STACME	16 IR 16 STACME	16 IL 16 STACME	.04	.04
14	16	3/8	16 ER 14 STACME	16 EL 14 STACME	16 IR 14 STACME	16 IL 14 STACME	.04	.04
12	16	3/8	16 ER 12 STACME	16 EL 12 STACME	16 IR 12 STACME	16 IL 12 STACME	.05	.05
10	16	3/8	16 ER 10 STACME	16 EL 10 STACME	16 IR 10 STACME	16 IL 10 STACME	.05	.05
8	16	3/8	16 ER 8 STACME	16 EL 8 STACME	16 IR 8 STACME	16 IL 8 STACME	.06	.06
6	16	3/8	16 ER 6 STACME	16 EL 6 STACME	16 IR 6 STACME	16 IL 6 STACME	.07	.07
5	22	1/2	22 ER 6 STACME	22 EL 6 STACME	22 IR 6 STACME	22 IL 6 STACME	.07	.07
5	22	1/2	22 ER 5 STACME	22 EL 5 STACME	22 IR 5 STACME	22 IL 5 STACME	.08	.09
4	22	1/2	22 ER 4 STACME	22 EL 4 STACME	22 IR 4 STACME	22 IL 4 STACME	.09	.09
4	22U	1/2U	22U ER/L 4 STACME		22U IR/L 4 STACME		.10	.43
3	22U	1/2U	22U ER/L 3 STACME		22U IR/L 3 STACME		.13	.43
4	27	5/8	27 ER 4 STACME	27 EL 4 STACME	27 IR 4 STACME	27 IL 4 STACME	.09	.09
3	27	5/8	27 ER 3 STACME	27 EL 3 STACME	27 IR 3 STACME	27 IL 3 STACME	.11	.11
2	33U	3/4U	33U ER/L 2 STACME		33U IR/L 2 STACME		.20	.67

Order example: 22 IR 5 STACME MXC

* Available only in BXC and BMA grades

** One cutting edge

Trapez - DIN 103

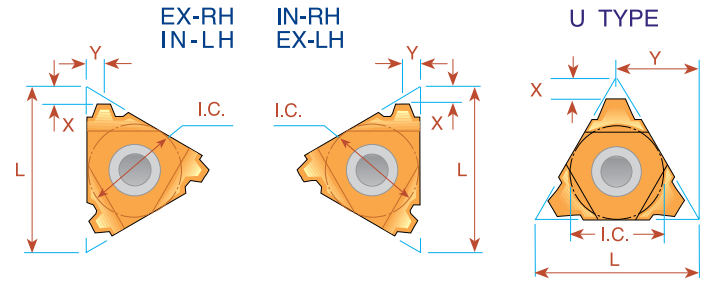
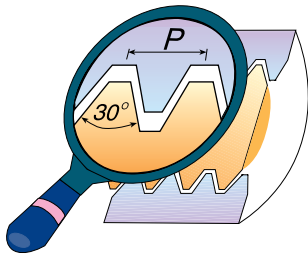

Pitch mm	L mm	I.C.	EXTERNAL Ordering Code		INTERNAL Ordering Code		X	Y
			Right Hand	Left Hand	Right Hand	Left Hand		
1.5	8	3/16	MINIATURE →		**08 IR 1.5 TR	**08 IL 1.5 TR	.02	.02
2.0	8U	3/16U	"U" MINIATURE →		*08U IR/L 2 TR		.04	.16
1.5	16	3/8	16 ER 1.5 TR	16 EL 1.5 TR			.04	.04
2.0	16	3/8	16 ER 2 TR	16 EL 2 TR	16 IR 2 TR	16 IL 2 TR	.04	.05
3.0	16	3/8	16 ER 3 TR	16 EL 3 TR	16 IR 3 TR	16 IL 3 TR	.05	.06
4.0	16	3/8	(1)16 ER 4 TR	(1)16 EL 4 TR	(1)16 IR 4 TR	(1)16 IL 4 TR	.05	.06
4.0	22	1/2	22 ER 4 TR	22 EL 4 TR	22 IR 4 TR	22 IL 4 TR	.07	.07
5.0	22	1/2	22 ER 5 TR	22 EL 5 TR	22 IR 5 TR	22 IL 5 TR	.08	.09
6.0	22	1/2	(1)22 ER 6 TR	(1)22 EL 6 TR	(1)22 IR 6 TR	(1)22 IL 6 TR	.08	.09
6.0	22U	1/2U	22U ER/L 6 TR		22U IR/L 6 TR		.08	.43
7.0	22U	1/2U	22U ER/L 7 TR		22U IR/L 7 TR		.09	.43
8.0	22U	1/2U	22U ER/L 8 TR		22U IR/L 8 TR		.10	.43
6.0	27	5/8	27 ER 6 TR	27 EL 6 TR	27 IR 6 TR	27 IL 6 TR	.09	.11
7.0	27	5/8	27 ER 7 TR	27 EL 7 TR	27 IR 7 TR	27 IL 7 TR	.09	.10
8.0	27U	5/8U	27U ER/L 8 TR		27U IR/L 8 TR		.10	.54
9.0	27U	5/8U	27U ER/L 9 TR		27U IR/L 9 TR		.12	.54
10.0	27U	5/8U	**27U ER/L 10 TR		**27U IR/L 10 TR		.13	.54
12.0	33U	3/4U	33U ER/L 12 TR		33U IR/L 12 TR		.15	.67

Order example: 22 IR 5 TR MXC

* Available only in BXC and BMA grades

** One cutting edge

(1) Special holder is required or standard holder can be amended by customer.

Trapez - DIN 103 Vertical

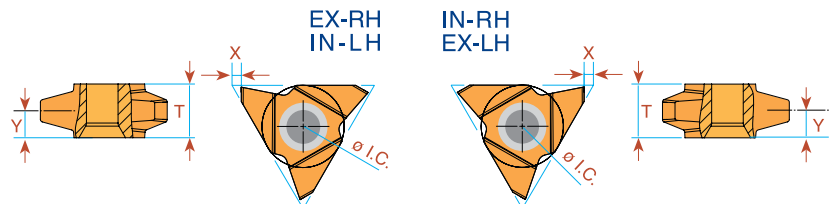

Pitch mm	L mm	I.C.	EXTERNAL Ordering Code		INTERNAL Ordering Code		X	Y	T
			Right Hand	Left Hand	Right Hand	Left Hand			
* 9	27	5/8	27V ER 9 TR	27V EL 9 TR	27V IR 9 TR	27V IL 9 TR	.07	.21	.41
** 10	27	5/8	27V ER 10 TR	27V EL 10 TR	27V IR 10 TR	27V IL 10 TR	.07	.21	.41
*** 12	27	5/8	27V ER 12 TR	27V EL 12 TR	27V IR 12 TR	27V IL 12 TR	.07	.21	.41

Order example: 27V ER 10 TR BMA

* Minimum bore: Ø2.56" ** Minimum bore: Ø2.56" *** Minimum bore: Ø2.87"

For Carbide Grade and Cutting Speed see page 66-67

PG - DIN 40430

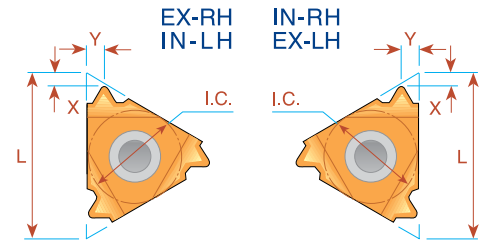
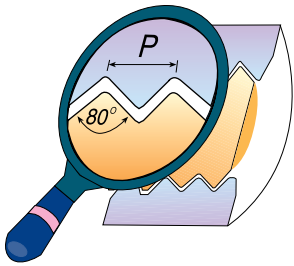

Pitch TPI	L mm	I.C.	EXTERNAL		INTERNAL		X	Y
			Right Hand	Standard	Right Hand	Standard		
20	8	3/16	MINIATURE →		*08 IR 20 PG	(PG 7)	.02	.03
18	11	1/4			11 IR 18 PG	(PG 9)	.03	.04
20	16	3/8	16 ER 20 PG	(PG 7)	16 IR 18 PG	(PG 11, 13.5, 16)	.03	.03
18	16	3/8	16 ER 18 PG	(PG 9, 11, 13.5, 16)	16 IR 18 PG	(PG 11, 13.5, 16)	.03	.04
16	16	3/8	16 ER 16 PG	(PG 21, 29, 36, 42, 48)	16 IR 16 PG	(PG 21, 29, 36, 42, 48)	.03	.04

Order example: 16 ER 16 PG BMA

* Available only in BXC and BMA grades

Sagengewinde- DIN 513

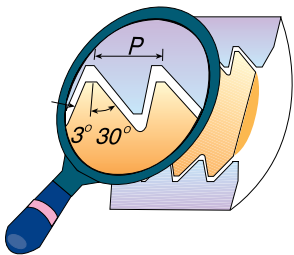

IMPORTANT NOTE:
In Carmex standard execution, the flank with the large angle is the leading edge. If otherwise required, please specify in your order.

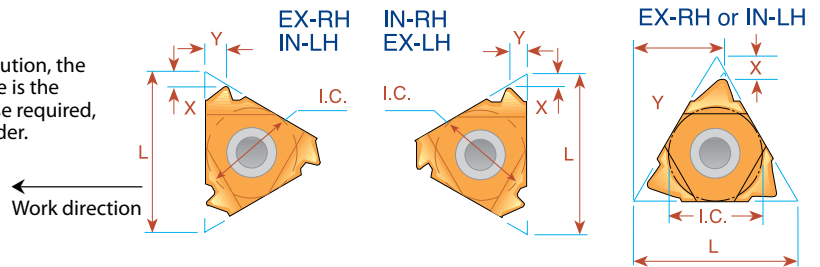

Pitch TPI	L mm	I.C.	EXTERNAL		X	Y	INTERNAL		X	Y
			Right Hand	Left Hand			Right Hand	Left Hand		
2.0	16	3/8	16 ER 2 SAGE	16 EL 2 SAGE	.04	.06	16 IR 2 SAGE	16 IL 2 SAGE	.05	.07
(1) 3.0	22	1/2	22 ER 3 SAGE	22 EL 3 SAGE	.06	.09	22 IR 3 SAGE	22 IL 3 SAGE	.07	.11
(1) 4.0	22	1/2	22 ER 4 SAGE	22 EL 4 SAGE	.07	.12	22 IR 4 SAGE	22 IL 4 SAGE	.09	.14
*5.0	22U	1/2U	22U ER 5 SAGE	22U EL 5 SAGE	.05	.46	22U IR 5 SAGE	22U IL 5 SAGE	.07	.46
*6.0	22U	1/2U	22U ER 6 SAGE	22U EL 6 SAGE	.05	.46	22U IR 6 SAGE	22U IL 6 SAGE	.08	.47

Order example: 22 IR 4 SAGE BMA

* Requires a special anvil AER 22U-1.5 SAGE 5/6, AEL 22U-1.5 SAGE 5/6, AIR 22U-1.5 SAGE 5/6, AIL 22U-1.5 SAGE 5/6.

(1) Requires a special anvil AER 22-1.5 SAGE 3/4, AEL 22-1.5 SAGE 3/4

AIR 22-1.5 SAGE 3/4, AIL 22-1.5 SAGE 3/4

For Carbide Grade and Cutting Speed see page 66-67

Round - DIN 405

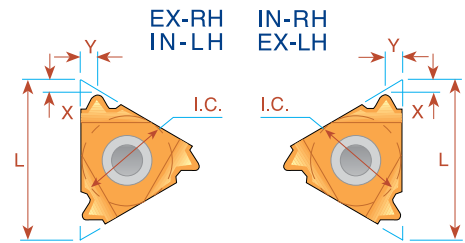
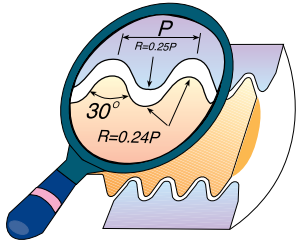

Pitch TPI	L mm	I.C.	EXTERNAL		X	Y	INTERNAL		X	Y
			Ordering Code Right Hand	Ordering Code Left Hand			Ordering Code Right Hand	Ordering Code Left Hand		
10	16	3/8	16 ER 10 RD	16 EL 10 RD	.04	.05	16 IR 10 RD	16 IL 10 RD	.04	.05
8	16	3/8	16 ER 8 RD	16 EL 8 RD	.06	.05	16 IR 8 RD	16 IL 8 RD	.06	.06
6	16	3/8	16 ER 6 RD	16 EL 6 RD	.06	.07	16 IR 6 RD	16 IL 6 RD	.06	.06
6	22	1/2	22 ER 6 RD	22 EL 6 RD	.06	.07	22 IR 6 RD	22 IL 6 RD	.06	.07
4	22	1/2	22 ER 4 RD	22 EL 4 RD	.09	.09	22 IR 4 RD	22 IL 4 RD	.09	.09
4	27	5/8	27 ER 4 RD	27 EL 4 RD	.09	.09	27 IR 4 RD	27 IL 4 RD	.09	.09

Order example: 27 IL 4 RD BMA

Round - DIN 20400

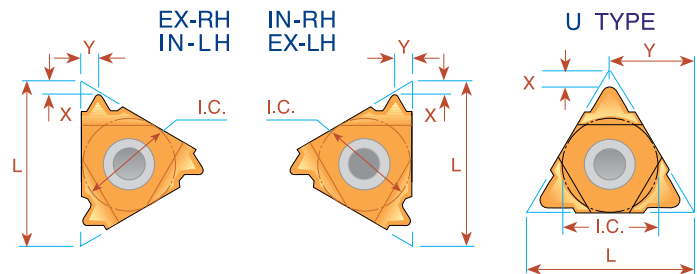
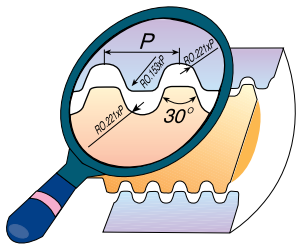

Pitch mm	L mm	I.C.	EXTERNAL	INTERNAL	X	Y
			Ordering Code Right Hand	Ordering Code Right Hand		
4.0	22	1/2	22 ER 4.0 RD 20400	22 IR 4.0 RD 20400	.06	.06
5.0	22	1/2	22 ER 5.0 RD 20400	22 IR 5.0 RD 20400	.07	.07
6.0	22	1/2	22 ER 6.0 RD 20400	22 IR 6.0 RD 20400	.07	.08
8.0	27U	5/8U	*27U - 8.0 RD 20400		.12	.54
10.0	27U	5/8U	*27U - 10.0 RD 20400		.13	.54

Order example: 22 ER 4.0 RD 20400 MXC

* Same insert for Internal and External Right Hand Thread

For Carbide Grade and Cutting Speed see page 66-67

UNJ UNJC, UNJF, UNJEF, UNJS

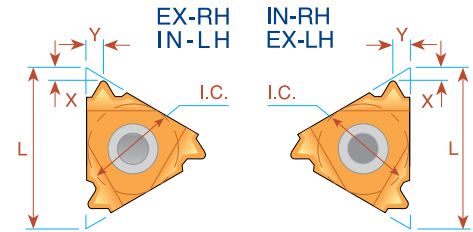
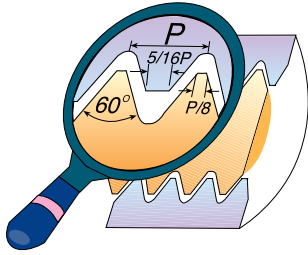

Pitch TPI	L mm	I.C.	EXTERNAL		INTERNAL		X	Y
			Ordering Code		Ordering Code			
			Right Hand	Left Hand	Right Hand	Left Hand		
48	11	1/4	11 ER 48 UNJ	11 EL 48 UNJ	11 IR 48 UNJ	11 IL 48 UNJ	.02	.02
44	11	1/4	11 ER 44 UNJ	11 EL 44 UNJ	11 IR 44 UNJ	11 IL 44 UNJ	.02	.02
40	11	1/4	11 ER 40 UNJ	11 EL 40 UNJ	11 IR 40 UNJ	11 IL 40 UNJ	.02	.02
36	11	1/4	11 ER 36 UNJ	11 EL 36 UNJ	11 IR 36 UNJ	11 IL 36 UNJ	.02	.02
32	11	1/4	11 ER 32 UNJ	11 EL 32 UNJ	11 IR 32 UNJ	11 IL 32 UNJ	.02	.02
28	11	1/4	11 ER 28 UNJ	11 EL 28 UNJ	11 IR 28 UNJ	11 IL 28 UNJ	.02	.02
24	11	1/4	11 ER 24 UNJ	11 EL 24 UNJ	11 IR 24 UNJ	11 IL 24 UNJ	.03	.03
20	11	1/4	11 ER 20 UNJ	11 EL 20 UNJ	11 IR 20 UNJ	11 IL 20 UNJ	.03	.04
18	11	1/4	11 ER 18 UNJ	11 EL 18 UNJ	11 IR 18 UNJ	11 IL 18 UNJ	.03	.04
16	11	1/4	11 ER 16 UNJ	11 EL 16 UNJ	11 IR 16 UNJ	11 IL 16 UNJ	.03	.04
14	11	1/4	11 ER 14 UNJ	11 EL 14 UNJ	11 IR 14 UNJ	11 IL 14 UNJ	.04	.04
48	16	3/8	16 ER 48 UNJ	16 EL 48 UNJ	16 IR 48 UNJ	16 IL 48 UNJ	.02	.02
44	16	3/8	16 ER 44 UNJ	16 EL 44 UNJ	16 IR 44 UNJ	16 IL 44 UNJ	.02	.02
40	16	3/8	16 ER 40 UNJ	16 EL 40 UNJ	16 IR 40 UNJ	16 IL 40 UNJ	.02	.02
36	16	3/8	16 ER 36 UNJ	16 EL 36 UNJ	16 IR 36 UNJ	16 IL 36 UNJ	.02	.02
32	16	3/8	16 ER 32 UNJ	16 EL 32 UNJ	16 IR 32 UNJ	16 IL 32 UNJ	.02	.02
28	16	3/8	16 ER 28 UNJ	16 EL 28 UNJ	16 IR 28 UNJ	16 IL 28 UNJ	.02	.02
24	16	3/8	16 ER 24 UNJ	16 EL 24 UNJ	16 IR 24 UNJ	16 IL 24 UNJ	.03	.03
20	16	3/8	16 ER 20 UNJ	16 EL 20 UNJ	16 IR 20 UNJ	16 IL 20 UNJ	.03	.04
18	16	3/8	16 ER 18 UNJ	16 EL 18 UNJ	16 IR 18 UNJ	16 IL 18 UNJ	.03	.04
16	16	3/8	16 ER 16 UNJ	16 EL 16 UNJ	16 IR 16 UNJ	16 IL 16 UNJ	.03	.04
14	16	3/8	16 ER 14 UNJ	16 EL 14 UNJ	16 IR 14 UNJ	16 IL 14 UNJ	.04	.05
13	16	3/8	16 ER 13 UNJ	16 EL 13 UNJ	16 IR 13 UNJ	16 IL 13 UNJ	.04	.05
12	16	3/8	16 ER 12 UNJ	16 EL 12 UNJ	16 IR 12 UNJ	16 IL 12 UNJ	.04	.06
11	16	3/8	16 ER 11 UNJ	16 EL 11 UNJ	16 IR 11 UNJ	16 IL 11 UNJ	.04	.06
10	16	3/8	16 ER 10 UNJ	16 EL 10 UNJ	16 IR 10 UNJ	16 IL 10 UNJ	.04	.06
9	16	3/8	16 ER 9 UNJ	16 EL 9 UNJ	16 IR 9 UNJ	16 IL 9 UNJ	.05	.06
8	16	3/8	16 ER 8 UNJ	16 EL 8 UNJ	16 IR 8 UNJ	16 IL 8 UNJ	.05	.06

Order example: 16 IR 16 UNJ MXC

For Carbide Grade and Cutting Speed see page 66-67

UNJ UNJC, UNJF, UNJEF, UNJS

Type B

Ground Profile with Sintered Chip-breaker

Pitch TPI	L	I.C. in	INTERNAL Ordering Code Right Hand	X	Y
32	11	1/4	11 IR B 32 UNJ	.02	.02
28	11	1/4	11 IR B 28 UNJ	.02	.02
24	11	1/4	11 IR B 24 UNJ	.02	.02
20	11	1/4	11 IR B 20 UNJ	.03	.04
18	11	1/4	11 IR B 18 UNJ	.03	.04
16	11	1/4	11 IR B 16 UNJ	.03	.04
14	11	1/4	11 IR B 14 UNJ	.03	.04



Order example: 11 IR B 20 UNJ BMA

Multitooth

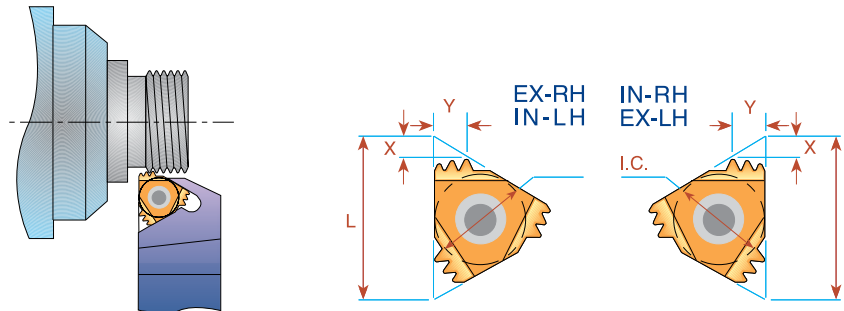

Pitch TPI	L	I.C. in	Number of Teeth	EXTERNAL Ordering Code	Anvil	INTERNAL Ordering Code	Anvil	X	Y
16	16	3/8	2	16 ER 16 UNJ 2M	AE16M	-	-	.06	.09
16	22	1/2	3	22 ER 16 UNJ 2M	AE22M	-	-	.09	.15

Order example: 22 ER 16 UNJ 2M BMA

MJ - ISO 5855

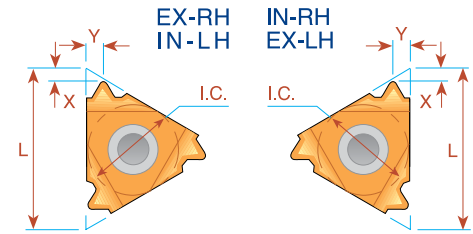
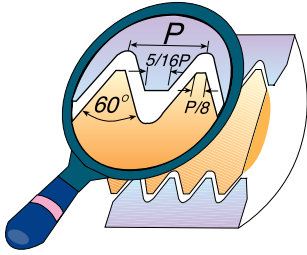

Pitch mm	L mm	I.C.	EXTERNAL		INTERNAL		
			Ordering Code	Right Hand	Ordering Code	Right Hand	X
1.0	11	1/4			11 IR 1.0 MJ	.03	.03
1.25	11	1/4			11 IR 1.25 MJ	.03	.04
1.5	11	1/4			11 IR 1.5 MJ	.03	.04
2.0	11	1/4			11 IR 2.0 MJ	.04	.04
1.0	16	3/8	16 ER 1.0 MJ		16 IR 1.0 MJ	.03	.03
1.25	16	3/8	16 ER 1.25 MJ		16 IR 1.25 MJ	.03	.04
1.5	16	3/8	16 ER 1.5 MJ		16 IR 1.5 MJ	.03	.04
2.0	16	3/8	16 ER 2.0 MJ		16 IR 2.0 MJ	.04	.05

Order example: 16 ER 1.5 MJ BMA

Type B

Ground Profile with Sintered Chip-breaker

Pitch mm	L	I.C. in	INTERNAL Ordering Code Right Hand	X	Y
1.0	11	1/4	11 IR B 1.0 MJ	.02	.02
1.5			11 IR B 1.5 MJ	.03	.04

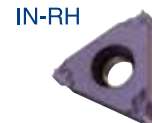

Order example: 11 IR B 1.5 MJ BMA

American Buttress

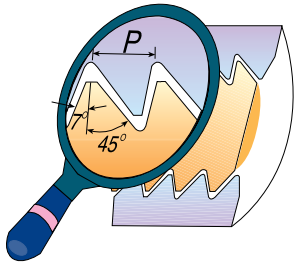

IMPORTANT NOTE:
In Carmex standard execution, the flank with the large angle is the leading edge. If otherwise required, please specify in your order.

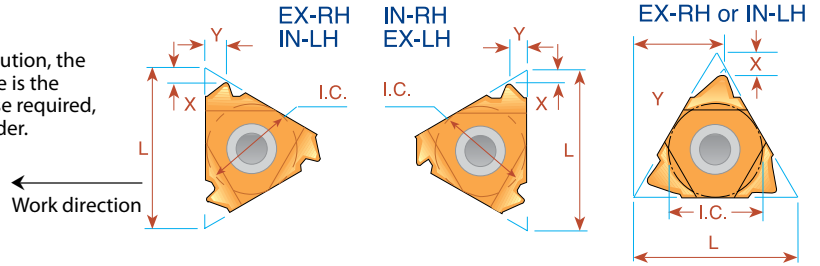

Pitch TPI	L mm	I.C.	EXTERNAL		INTERNAL		X	Y
			Ordering Code Right Hand	Ordering Code Left Hand	Ordering Code Right Hand	Ordering Code Left Hand		
20	11	1/4	11 ER 20 ABUT	11 EL 20 ABUT	11 IR 20 ABUT	11 IL 20 ABUT	.04	.05
16	11	1/4	11 ER 16 ABUT	11 EL 16 ABUT	11 IR 16 ABUT	11 IL 16 ABUT	.04	.06
20	16	3/8	16 ER 20 ABUT	16 EL 20 ABUT	16 IR 20 ABUT	16 IL 20 ABUT	.04	.05
16	16	3/8	16 ER 16 ABUT	16 EL 16 ABUT	16 IR 16 ABUT	16 IL 16 ABUT	.04	.06
12	16	3/8	16 ER 12 ABUT	16 EL 12 ABUT	16 IR 12 ABUT	16 IL 12 ABUT	.06	.08
10	16	3/8	16 ER 10 ABUT	16 EL 10 ABUT	16 IR 10 ABUT	16 IL 10 ABUT	.06	.09
8	22	1/2	22 ER 8 ABUT	22 EL 8 ABUT	22 IR 8 ABUT	22 IL 8 ABUT	.08	.13
6	22	1/2	22 ER 6 ABUT	22 EL 6 ABUT	22 IR 6 ABUT	22 IL 6 ABUT	.08	.13
(1) 4	22U	1/2U	22U ER 4 ABUT	22U EL 4 ABUT	22U IR 4 ABUT	22U IL 4 ABUT	.09	.37
(2) 3	27U	5/8U	27U ER 3 ABUT	27U EL 3 ABUT	27U IR 3 ABUT	27U IL 3 ABUT	.12	.46

Order example: 16 IL 12 ABUT MXC

Most applications requires anvil change in toolholder see page 71

(1) Requires a special anvil AE 22U-1.5 ABUT4, AI22U-1.5 ABUT4

(2) Requires a special anvil AE 27U-1.5 ABUT3, AI27U-1.5 ABUT3

Multitooth

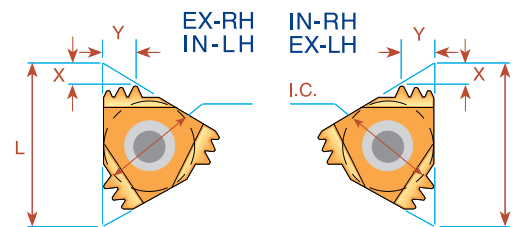
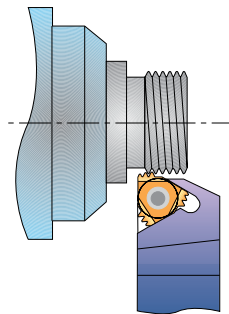

Pitch TPI	L	I.C. in	Number of Teeth	EXTERNAL	Anvil	INTERNAL	Anvil	X	Y
				Ordering Code		Ordering Code			
12	22	1/2	2	22 ER 12 ABUT 2M	AE22M	22 IR 16 ABUT 2M	AI22M	.10	.16

Order example: 22 IR 16 ABUT 2M BMA

For Carbide Grade and Cutting Speed see page 66-67

American Buttress Vertical

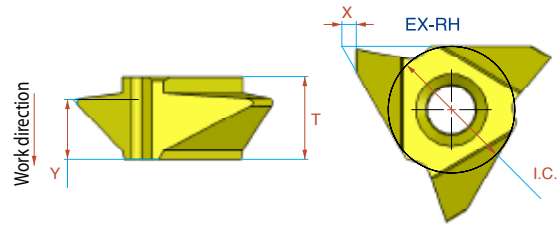

Pitch TPI	L mm	I.C.	EXTERNAL			INTERNAL				
			Ordering Code Right Hand	X	Y	T	Ordering Code Right Hand	X	Y	T
* 4	27	5/8	*27V ER 4 ABUT	0.07	0.30	0.41	27V IR 4 ABUT	0.07	0.30	0.41
** 3	27	5/8	*27V ER 3 ABUT	0.07	0.30	0.41	27V IR 3 ABUT	0.07	0.24	0.41

* For EXT. RH use only holders SER 1000M27V-ABUT 4/3-T10, SER1250P27V-ABUT 4/3-T10

* Minimum bore: Ø2.17" ** Minimum bore: Ø2.76"

OIL Threads API Round

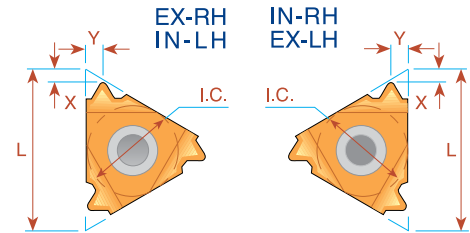
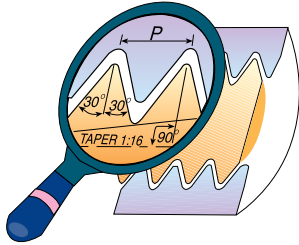

Pitch TPI	L mm	I.C.	Taper IPF	EXTERNAL Ordering Code Right Hand	INTERNAL Ordering Code Right Hand	X	Y
10	16	3/8	0.75	16 ER 10 API RD	16 IR 10 API RD	.06	.06
8	16	3/8	0.75	16 ER 8 API RD	16 IR 8 API RD	.05	.06

Multitooth

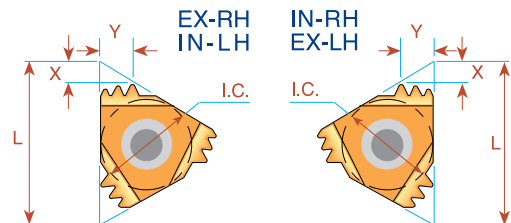
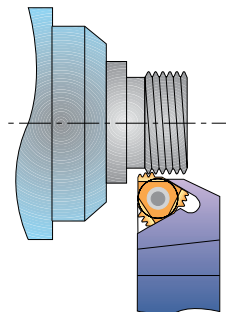

Pitch TPI	L mm	I.C.	Number of Teeth	EXTERNAL Ordering Code	Anvil	INTERNAL Ordering Code	Anvil	X	Y
10	22	1/2	2	22 ER 10API RD 2M	AE22M	22 IR 10API RD 2M	AI22M	.09	.15
10	27	5/8	3	27 ER 10API RD 3M	AE27M	27 IR 10API RD 3M	AI27M	.15	.24
8	27	5/8	2	27 ER 8API RD 2M	AE27M	27 IR 8API RD 2M	AI27M	.12	.18

Order example: 27 IR 10 API RD 3M MXC
For recommended number of passes see page 68

For Carbide Grade and Cutting Speed see page 66-67

OIL Threads

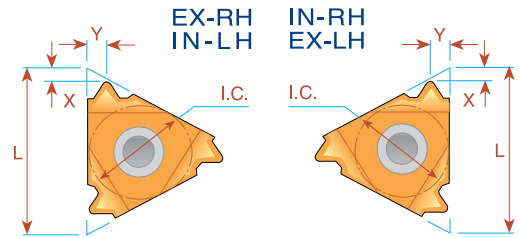
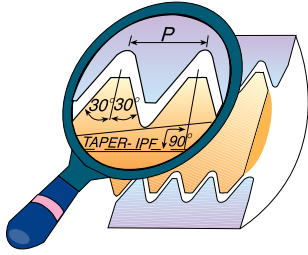

V-0.040

Pitch TPI	L mm	I.C.	Taper IPF	EXTERNAL Ordering Code Right Hand	INTERNAL Ordering Code Right Hand	X	Y	Connection No. or Size
5	22	1/2	3	22 ER 5 API 403	22 IR 5 API 403	.07	.10	23/8-4 1/2 REG

V-0.038R

Pitch TPI	L mm	I.C.	Taper IPF	EXTERNAL Ordering Code Right Hand	INTERNAL Ordering Code Right Hand	X	Y	Connection No. or Size
4	27	5/8	2	27 ER 4 API 382	27 IR 4 API 382	.08	.08	NC23-NC50
4	27	5/8	3	27 ER 4 API 383	27 IR 4 API 383	.08	.11	NC56-NC77

V-0.050

Pitch TPI	L mm	I.C.	Taper IPF	EXTERNAL Ordering Code Right Hand	INTERNAL Ordering Code Right Hand	X	Y	Connection No. or Size
4	27	5/8	2	27 ER 4 API 502	27 IR 4 API 502	.08	.12	65/8 REG
4	27	5/8	3	27 ER 4 API 503	27 IR 4 API 503	.08	.12	5 1/2, 7 5/8, 8 5/8 REG

V-0.055

Macaroni Tubing (MT)

American Macaroni Tubing (AMT)

American Mining Macaroni Tubing (AMMT)

Pitch TPI	L	I.C. in	Taper IPF	EXTERNAL Ordering Code Right Hand	INTERNAL Ordering Code Right Hand	X	Y	Connection No. or Size
6	22	1/2	1.5	22 ER 6 API 551.5	-	.08	.07	NC10,NC12,NC13,NC16
6	16	3/8	1.5	-	16 IR 6 API 551.5	.08	.07	NC10,NC12,NC13 *
6	22	1/2	1.5	-	22 IR 6 API 551.5	.08	.07	NC16 **

* For NC10,NC12 use holder SIR062516CB
For NC13 use holders SIR0750P16/SIR0750P16B/SIR0750S16CB

** For NC16 use holder SIR1000R22

For Carbide Grade and Cutting Speed see page 66-67

OIL Threads Extreme - Line Casing

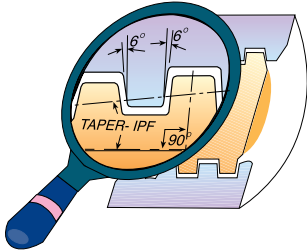

Pitch TPI	L mm	I.C.	Taper IPF	EXTERNAL	INTERNAL	X	Y	Connection No. or Size
				Ordering Code Right Hand	Ordering Code Right Hand			
6	22	1/2	1.50	22 ER 6 EL 1.5	22 IR 6 EL 1.5	.07	.07	5-7 ⁵ / ₈
5	22	1/2	1.25	22 ER 5 EL 1.25	22 IR 5 EL 1.25	.09	.09	8 ⁵ / ₈ -10 ³ / ₄

Buttress Casing

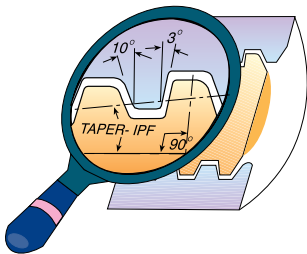

Pitch TPI	L mm	I.C.	Taper IPF	EXTERNAL	INTERNAL	X	Y	Connection No. or Size
				Ordering Code Right Hand	Ordering Code Right Hand			
5	22	1/2	0.75	22 ER 5 BUT 0.75	22 IR 5 BUT 0.75	.09	.09	4 ¹ / ₂ -13 ³ / ₈
5	22	1/2	1.00	22 ER 5 BUT 1.0	22 IR 5 BUT 1.0	.09	.09	16-20

Order example: 22 ER 5 BUT 0.75 MXC

HUGHES

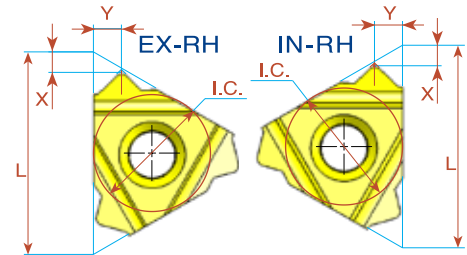
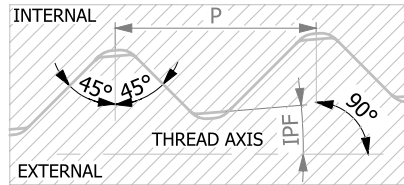

Pitch TPI	L mm	I.C.	Taper IPF	EXTERNAL	INTERNAL	X	Y	Connection No. or Size
				Ordering Code Right Hand	Ordering Code Right Hand			
3.5	27	5/8	2	27 ER 3.5 H 902	27 IR 3.5 H 902	.11	.15	3 1/2 - 6 5/8
3.5	27	5/8	3	27 ER 3.5 H 903	27 IR 3.5 H 903	.11	.15	7 - 8 5/8
3	27	5/8	1.25	27 ER 3 SLH 90	27 IR 3 SLH 90	.13	.18	2 3/8 - 3 1/2

PAC

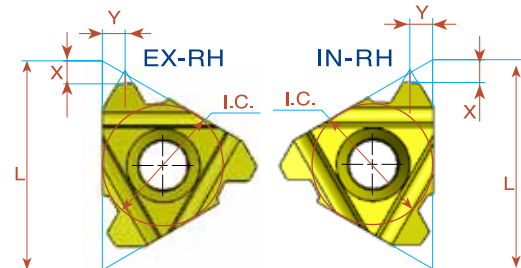
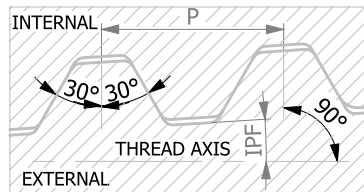

Pitch TPI	L mm	I.C.	Taper IPF	EXTERNAL	INTERNAL	X	Y	Connection No. or Size
				Ordering Code Right Hand	Ordering Code Right Hand			
4	22	1/2	1.5	22 ER 4 PAC	22 IR 4 PAC	.09	.09	2 1/2 - 2 7/8
4	27	5/8	1.5	27 ER 4 PAC	27 IR 4 PAC	.09	.09	2 1/2 - 2 7/8

VAM

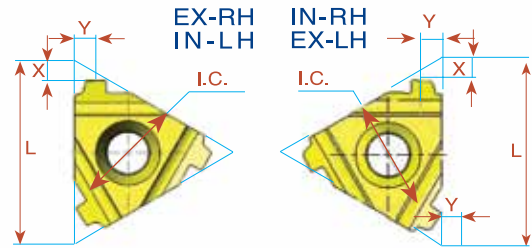
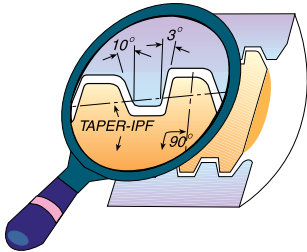

Pitch TPI	L mm	I.C.	Taper IPF	EXTERNAL		INTERNAL		X	Y	Connection No. or Size
				Ordering Code Right Hand		Ordering Code Right Hand				
8	16	3/8	0.75	16 ER 8 VAM		16 IR 8 VAM		.07	.07	2 3/8" - 2 7/8"
6	22	1/2	0.75	22 ER 6 VAM		22 IR 6 VAM		.09	.09	3 1/2" - 4 1/2"
5	22	1/2	0.75	22 ER 5 VAM		22 IR 5 VAM		.09	.10	5" - 13 3/8"

Order example: 16 ER 8 VAM BMA

NPS

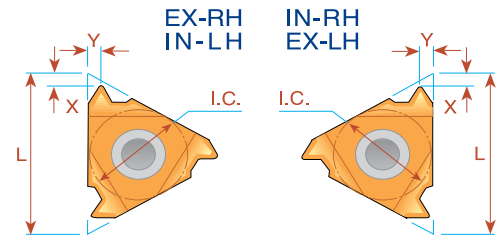
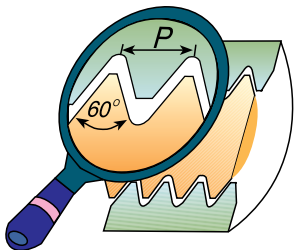

Pitch TPI	L mm	I.C.	EXTERNAL		INTERNAL		X	Y
			Ordering Code Right Hand	Ordering Code Left Hand	Ordering Code Right Hand	Ordering Code Left Hand		
18	16	3/8	16 ER 18 NPS	16 EL 18 NPS	16 iR 18 NPS	16 iL 18 NPS	.03	.04
14	16	3/8	16 ER 14 NPS	16 EL 14 NPS	16 iR 14 NPS	16 iL 14 NPS	.04	.05
11.5	16	3/8	16 ER 11.5 NPS	16 EL 11.5 NPS	16 iR 11.5 NPS	16 iL 11.5 NPS	.04	.06
8	16	3/8	16 ER 8 NPS	16 EL 8 NPS	16 iR 8 NPS	16 iL 8 NPS	.05	.07

Order example: 30-11.5 NPS MT7

* One cutting edge

For Carbide Grade and Cutting Speed see page 66-67





Thread Turning Toolholders and Kits



Contents:	Page:	Contents:	Page:
Product Identification	42	Gang Toolholders	49
External Toolholders	43	Quick Change	
External Toolholders with Top Clamp	44	External Toolholders	50
Vertical Toolholders	44	Internal Toolholders	51
Slim Throat Toolholders	44	Special Thread Turning Application	52
External Thread Turning Toolholder	45	Large Profile Range	52
Internal Toolholders	46	Thread Helix Angle	53
Internal Toolholders with Coolant Bore	47	Standard and Slanted Anvils	53
Internal Toolholders with Top Clamp	47	Anvil Kits	54
Toolholders with 3.5° Helix Angle	47	Standard Kits	55
Carbide Shank Boring Bars	48	Miniature & Ultra-miniature Kits	55
Drophead Toolholders	48	Inserts' Kits	56
Vertical Toolholders	49	Threading & Boring Combination Kit	57

Product Identification

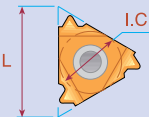
Threading Toolholders Ordering Codes

S	E	R	0750	K	16	
Clamping Method D = Clamp S = Screw	E = External I = Internal	R = Right Hand L = Left Hand	Shank Cross Section: External toolholders square shank 0750=3/4 x 3/4 	Length of Toolholder: D = 2.5 F = 3.25 H = 4 K = 5 L = 5.5 M = 6 P = 7 R = 8 S = 10 T = 12 U = 14 V = 16	Insert Pocket Size  L mm I.C. 06 5/32" 08 3/16" 08U 3/16"U 11 1/4" 16 3/8" 22 1/2" 22U 1/2"U 27 5/8" 27U 5/8"U 33U 3/4"U	B - With coolant bore CB - Carbide shank V - Vertical (on edge) O - Offset style D - Drop head G - Gang tool U - U type
			Internal toolholders & boring bars round shank 0750 = Diam. of 3/4 			

External Toolholders

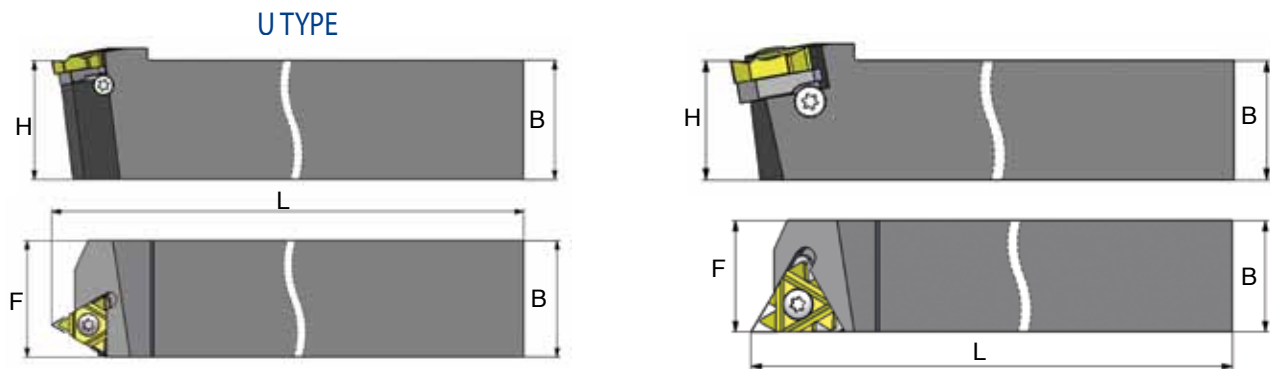

Ordering Code Right Hand	 L mm	B=H	L	F	Insert Screw	Anvil Screw	Torx Key	RH Anvil	LH Anvil
*SER 0310 H11	11	.31	4.00	.43	S11	-	K11	-	-
*SER 0375 H11	11	.38	4.00	.43	S11	-	K11	-	-
SER 0375 D16	16	.38	2.50	.63	S16	A16	K16	AE16	AI16
SER 0500 F16	16	.50	3.25	.63	S16	A16	K16	AE16	AI16
SER 0625 H16	16	.63	4.00	.63	S16	A16	K16	AE16	AI16
SER 0750 K16	16	.75	5.00	.75	S16	A16	K16	AE16	AI16
SER 1000 M16	16	1.00	6.00	1.00	S16	A16	K16	AE16	AI16
SER 1250 P16	16	1.25	7.00	1.25	S16	A16	K16	AE16	AI16
SER 1000 M22	22	1.00	6.00	1.00	S22	A22	K22	AE22	AI22
SER 1250 P22	22	1.25	7.00	1.25	S22	A22	K22	AE22	AI22
SER 1500 R22	22	1.50	8.00	1.50	S22	A22	K22	AE22	AI22
SER 1000 M22U	22U	1.00	6.00	1.10	S22	A22	K22	AE22U	AI22U
SER 1250 P22U	22U	1.25	7.00	1.25	S22	A22	K22	AE22U	AI22U
SER 1500 R22U	22U	1.50	8.00	1.50	S22	A22	K22	AE22U	AI22U
SER 1000 M27	27	1.00	6.00	1.25	S27	A27	K27	AE27	AI27
SER 1250 P27	27	1.25	7.00	1.25	S27	A27	K27	AE27	AI27
SER 1500 R27	27	1.50	8.00	1.50	S27	A27	K27	AE27	AI27
SER 1000 M27U	27U	1.00	6.00	1.25	S27	A27	K27	AE27U	AI27U
SER 1250 P27U	27U	1.25	7.00	1.25	S27	A27	K27	AE27U	AI27U
SER 1500 R27U	27U	1.50	8.00	1.50	S27	A27	K27	AE27U	AI27U
SER 1000 M33U	33U	1.00	6.00	1.45	S33	-	K33	-	-
SER 1250 P33U	33U	1.25	7.00	1.45	S33	-	K33	-	-

*Toolholders with no anvil

For **LEFT HAND** toolholders specify **SEL** instead of **SER**

Toolholders are made with a **1.5° Helix Angle**. For other Helix Angles please consult helix angle chart (page 71) in the technical section of this catalogue.

External toolholders with top clamp

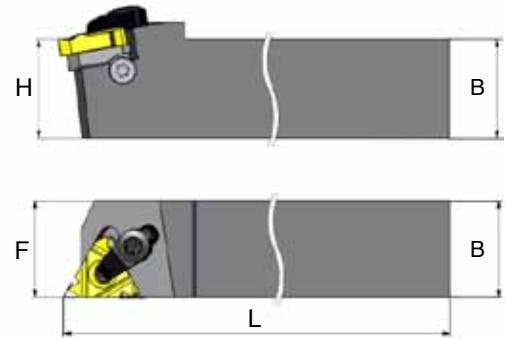

Ordering Code Right Hand	 L mm	B=H	L	F	Insert Screw	Clamp	Anvil Screw	Torx Key	RH Anvil	LH Anvil
DER 0750 K16	16	.75	5.0	.75	S16	C16	A16S	K16	AE16	AI16
DER 1000 M16	16	1.00	6.0	1.00	S16	C16	A16S	K16	AE16	AI16
*DER 1000 M22	22	1.00	6.0	1.00	S22	C22	A22	K22	AE22	AI22

For **LEFT HAND** toolholders specify **DEL** instead of **DER**

Toolholders are made with a **1.5° Helix Angle**. For other Helix Angles please consult helix angle chart in the technical section of this catalogue. Two clamping methods can be used: screw or top clamp.

*Use K21 torx key for C22 clamp

Vertical toolholders

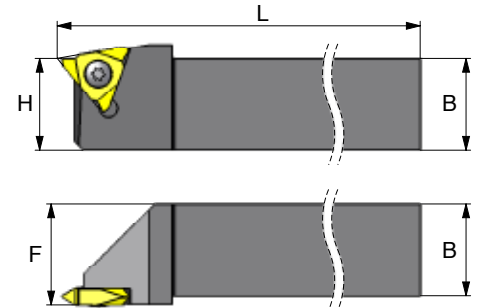

Ordering Code Right Hand	 mm	B=H	L	F	Insert Screw	Torx Key
SER 0750 K16V	16	.75	5.0	.87	S16S	K16
SER 1000 M16V	16	1.00	6.0	1.06	S16S	K16
SER 1000 M22V	22	1.00	6.0	1.08	S22S	K22
SER 1000 M27V-T10	27	1.00	6.0	1.42	S27	K27
SER 1000 M27V-ABUT 4/3-T10	27	1.00	6.0	1.42	S27	K27
SER 1250 P27V-T10	27	1.25	7.0	1.42	S27	K27
SER 1250 P27V-ABUT 4/3-T10	27	1.25	7.0	1.42	S27	K27

Slim Throat toolholders

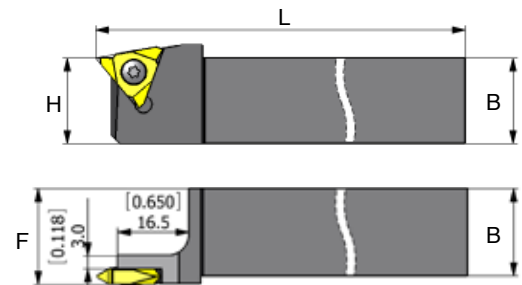

Ordering Code Right Hand	 mm	B=H	L	F	Insert Screw	Torx Key
SER 0625 H16VS	16	0.63	4.0	0.71	S16S	K16
SER 0750 K16VS	16	0.75	5.0	0.87	S16S	K16
SER 1000 M16VS	16	1.00	6.0	1.06	S16S	K16

External Thread Turning Toolholder with Internal Coolant

Carmex has developed a unique external thread turning holder with internal coolant to the cutting edge.

The holder includes two connecting options through an elbow fitting and a top clamp directing the coolant flow to the cutting edge.

The coolant flow provides:

- Better chip control, and chip flow
- Longer tool life and high performance
- Reduces the cutting edge temperature
- Available RH and LH tool holders
- Coated holders provides abrasive resistance

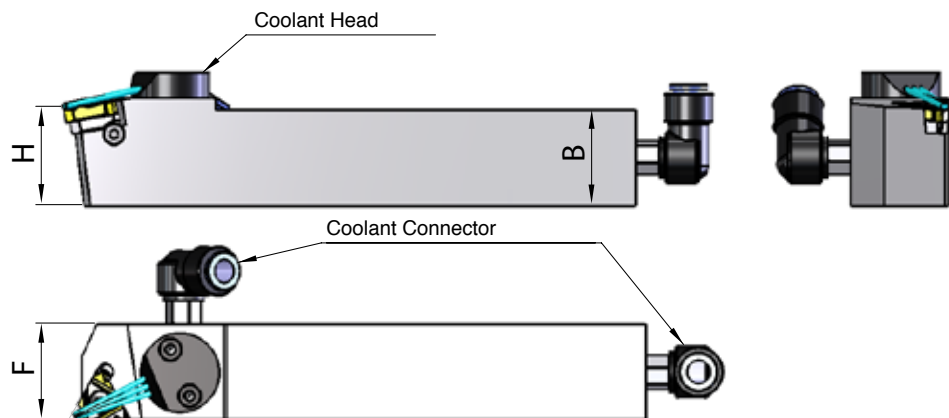
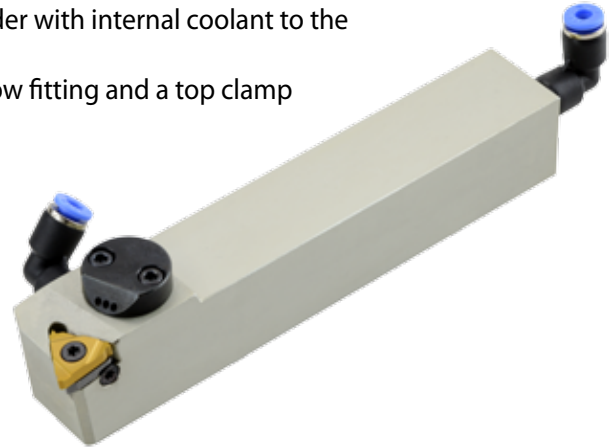

Ordering Code	 L mm	B=H	L	F	Insert Screw	Anvil Screw	Torx + Key	RH Anvil	LH Anvil	Coolant* Connector mm
SER 0750 K16B	16	.75	5.00	.75	S16P	A16P	K16P	AE16	AI16	Ø4 / Ø6
SER 1000 M16B	16	1.00	6.00	1.00	S16P	A16P	K16P	AE16	AI16	Ø4 / Ø6
SER 1000 M22B	22	1.00	6.00	1.00	S22P	A22P	K22P	AE22	AI16	Ø4 / Ø6
SER 1000 M27B	27	1.00	6.00	1.25	S27P	A27P	K27P	AE27	AI27	Ø4 / Ø6
SER 1250 P16B	16	1.25	7.00	1.25	S16P	A16P	K16P	AE16	AI16	Ø4 / Ø6
SER 1250 P22B	22	1.25	7.00	1.25	S22P	A22P	K22P	AE22	AI22	Ø4 / Ø6
SER 1250 P27B	27	1.25	7.00	1.25	S27P	A27P	K27P	AE27	AI27	Ø4 / Ø6

For **LEFT HAND** toolholders specify **SEL** instead of **SER**

Toolholders made with 1.5° helix angle

Please consult the helix angle chart page 71 in the technical section of this catalog

* Standard packing with Ø6 mm

Internal Toolholders

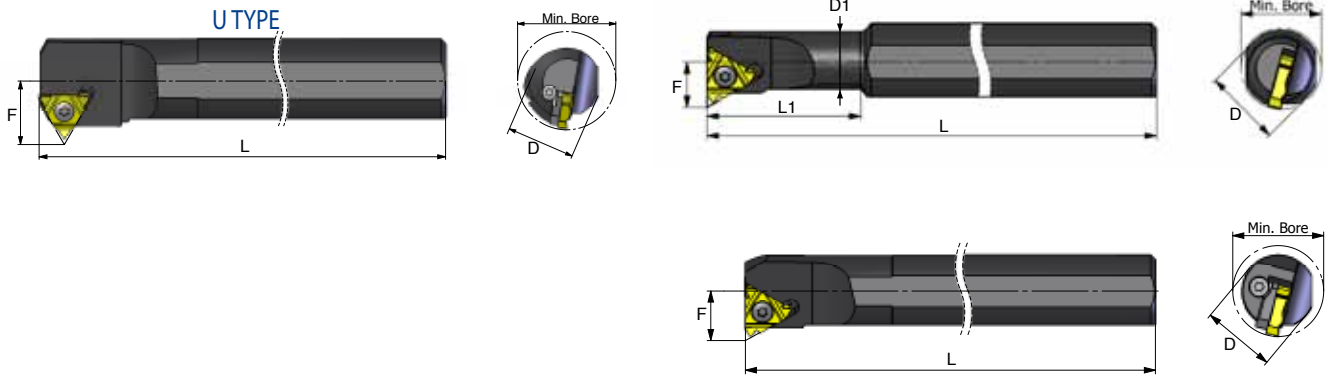

Ordering Code Right Hand	 L mm	D	D1	Min Bore Diam.	L	L1	F	Insert Screw	Anvil Screw	Torx Key	RH Anvil	LH Anvil
*SIR 0205 H06	6	.50	.20	.24	4.0	.47	.17	S06	-	K06	-	-
*SIR 0265 K08	8	.62	.26	.31	5.0	.70	.21	S08	-	K08	-	-
*SIR 0310 K08U	8U	.62	.29	.35	5.0	.83	.26	S08	-	K08	-	-
*SIR 0375 H11	11	.38	.38	.47	4.0	-	.28	S11	-	K11	-	-
*SIR 0375 K11	11	.62	.38	.47	5.0	1.00	.28	S11	-	K11	-	-
*SIR 0500 L11	11	.62	.50	.58	5.5	1.25	.34	S11	-	K11	-	-
*SIR 0500 M16	16	.62	.50	.64	6.0	1.25	.39	S16S	-	K16	-	-
*SIR 0625 P16	16	.75	.62	.75	7.0	1.57	.45	S16S	-	K16	-	-
SIR 0750 P16	16	.75	.75	.90	7.0	-	.51	S16	A16	K16	AI16	AE16
SIR 1000 R16	16	1.00	1.00	1.16	8.0	-	.65	S16	A16	K16	AI16	AE16
SIR 1250 S16	16	1.25	1.25	1.40	10.0	-	.77	S16	A16	K16	AI16	AE16
SIR 1500 T16	16	1.50	1.50	1.65	12.0	-	.90	S16	A16	K16	AI16	AE16
*SIR 0750 P22	22	.75	.75	.90	7.0	-	.59	S22S	-	K22	-	-
SIR 1000 R22	22	1.00	1.00	1.16	8.0	-	.71	S22	A22	K22	AI22	AE22
SIR 1250 S22	22	1.25	1.25	1.50	10.0	-	.85	S22	A22	K22	AI22	AE22
SIR 1500 T22	22	1.50	1.50	1.75	12.0	-	.98	S22	A22	K22	AI22	AE22
SIR 1250 S22U	22U	1.25	1.25	1.50	10.0	-	.95	S22	A22	K22	AI22U	AE22U
SIR 1500 T22U	22U	1.50	1.50	1.75	12.0	-	1.08	S22	A22	K22	AI22U	AE22U
SIR 1250 S27	27	1.25	1.25	1.56	10.0	-	.88	S27	A27	K27	AI27	AE27
SIR 1500 T27	27	1.50	1.50	1.80	12.0	-	1.00	S27	A27	K27	AI27	AE27
SIR 2000 U27	27	2.00	2.00	2.30	14.0	-	1.25	S27	A27	K27	AI27	AE27
SIR 2500 V27	27	2.50	2.50	2.80	16.0	-	1.50	S27	A27	K27	AI27	AE27
SIR 1250 S27U	27U	1.25	1.25	1.56	10.0	-	1.00	S27	A27	K27	AI27U	AE27U
SIR 1500 T27U	27U	1.50	1.50	1.80	12.0	-	1.13	S27	A27	K27	AI27U	AE27U
SIR 2000 U27U	27U	2.00	2.00	2.30	14.0	-	1.37	S27	A27	K27	AI27U	AE27U
SIR 2500 V27U	27U	2.50	2.50	2.80	16.0	-	1.61	S27	A27	K27	AI27U	AE27U
*SIR 2000 U33U	33U	2.00	2.00	2.50	14.0	-	1.50	S33	-	K33	-	-

*Toolholders with no anvil

For **LEFT HAND** toolholders specify **SIL** instead of **SIR**

Toolholders are made with a **1.5° Helix Angle**. For other Helix Angles please consult helix angle chart (page 71) in the technical section of this catalogue.

Internal toolholders with coolant bore

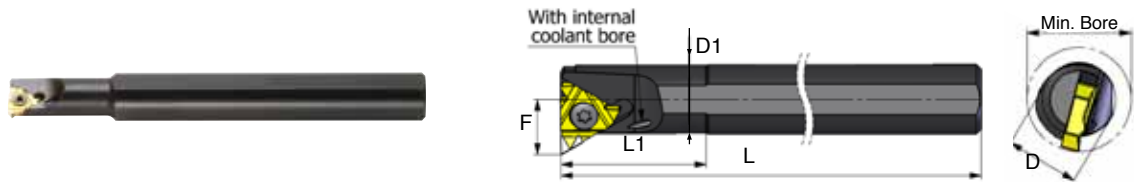

Ordering Code Right Hand	 L mm	D	D1	Min Bore Diam.	L	L1	F	Insert Screw	Anvil Screw	Torx Key	RH Anvil	LH Anvil
*SIR 0375 K11B	11	.62	.38	.47	5.0	.98	.28	S11	-	K11	-	-
*SIR 0500 M16B	16	.62	.50	.64	6.0	1.26	.39	S16S	-	K16	-	-
*SIR 0625 P16B	16	.75	.63	.75	7.0	1.57	.45	S16S	-	K16	-	-
SIR 0750 P16B	16	.75	.75	.90	7.0	-	.90	S16	A16	K16	AI16	AE16
SIR 1000 R16B	16	1.00	1.00	1.16	8.0	-	.65	S16	A16	K16	AI16	AE16
SIR 1000 R22B	22	1.00	1.00	1.16	8.0	-	.71	S22	A22	K22	AI22	AE22

*Toolholders with no anvil

For **LEFT HAND** toolholders specify **SIL** instead of **SIR**

Toolholders are made with a **1.5° Helix Angle**. For other Helix Angles please consult helix angle chart (page 71) in the technical section of this catalogue.

Internal toolholders with top clamp

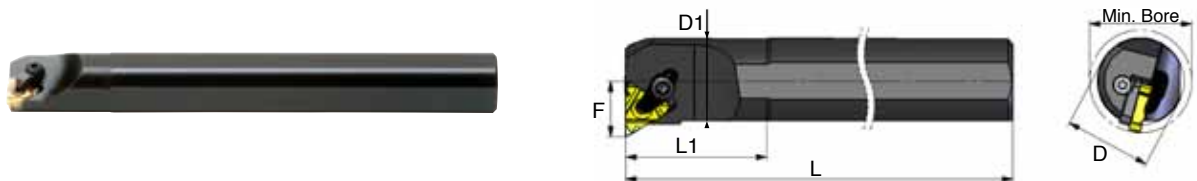

Ordering Code Right Hand	 L mm	D	D1	Min Bore Diam.	L	L1	F	Insert Screw	Clamp	Anvil Screw	Torx Key	RH Anvil	LH Anvil
DIR 0750 P16	16	.75	.75	.90	7.0	-	.51	S16	C16	A16S	K16	AI16	AE16
DIR 1000 R16	16	1.00	1.00	1.16	8.0	-	.65	S16	C16	A16S	K16	AI16	AE16
DIR 1250 S16	16	1.25	1.25	1.40	10.0	-	.77	S16	C16	A16S	K16	AI16	AE16
* DIR 1000 R22	22	1.00	1.00	1.16	8.0	-	.71	S22	C22	A22	K22	AI22	AE22

For **LEFT HAND** toolholders specify **DIL** instead of **DIR**

Two clamping methods can be used: screw or top clamp.

*Use K21 torx key for C22 clamp

Toolholders with 3.5° Helix Angle

Ordering Code Right Hand	 L mm	D mm	D1 mm	Min Bore Diam. mm	L mm	L1 mm	F mm	Insert Screw	Torx Key
SIR 0016 P16B-3.5	16	20	16	19	170	40	13.7	S16S	K16
SIR 0020 P22B-3.5	22	20	20	24	170	-	15.6	S22S	K22

For **LEFT HAND** toolholders specify **SIL** instead of **SIR**

Carbide Shank Threading Bars With coolant bore

Carbide Shank Threading Bars are used when Chatter and deflection are expected due to long overhang in deep small bores.

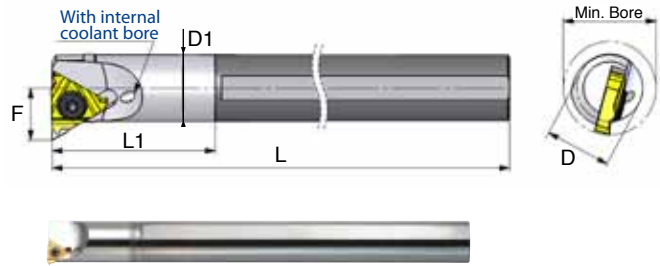

Ordering Code Right Hand	 L mm	D	D1	Min Bore Diam.	L	L1	F	Insert Screw	Anvil Screw	Torx Key	RH Anvil	LH Anvil
SIR 0205 H06CB	6	.25	.20	.24	4.0	1.02	.17	S06	-	K06	-	-
SIR 0265 K08CB	8	.31	.26	.31	5.0	1.22	.21	S08	-	K08	-	-
SIR 0310K08UCB	8U	.31	.29	.35	5.0	1.38	.26	S08	-	K08	-	-
SIR 0375 M11CB	11	.38	.38	.47	6.0	-	.28	S11	-	K11	-	-
SIR 0500 P11CB	11	.50	.50	.58	7.0	-	.34	S11	-	K11	-	-
SIR 0500 P16CB	16	.50	.50	.64	7.0	-	.40	S16S	-	K16	-	-
SIR 0625 R16CB	16	.62	.62	.75	8.0	-	.46	S16S	-	K16	-	-
*SIR 0750 S16CB	16	.75	.75	.90	10.0	-	.54	S16	A16	K16	Al16	AE16
*SIR 1000 S16CB	16	1.00	1.00	1.10	10.0	-	.64	S16	A16	K16	Al16	AE16

*Carbide shank Threading bars with anvil
For **LEFT HAND** toolholders specify **SIL** instead of **SIR**

Drophead Toolholders

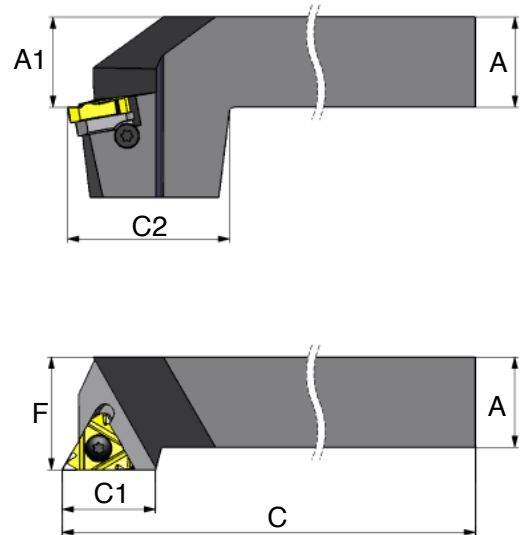

Ordering Code Right Hand	 L mm	A	A1	C	C1	F	C2	Insert Screw	Anvil Screw	Torx Key	RH Anvil	LH Anvil
SER 0750 K16D	16	.75	.75	5.0	.84	1.00	1.5	S16	A16	K16	AE16	Al16
SER 1000 M16D	16	1.00	1.00	6.0	.84	1.25	1.5	S16	A16	K16	AE16	Al16
SER 1000 M22D	22	1.00	1.00	6.0	1.00	1.25	1.5	S22	A22	K22	AE22	Al22

Vertical Toolholders

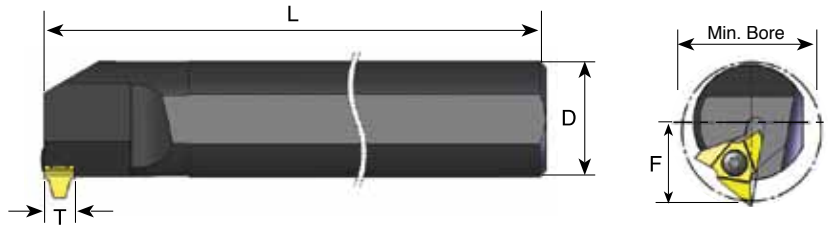

Ordering Code Right Hand	L	D	* Min Bore Diam.	L	F	T	Insert Screw	Torx Key
SIR 1250 S27V-T10	27	1.25	1.65	10	0.94	0.41	S27	K27
SIR 1500 T27V-T10	27	1.5	1.80	12	1.05	0.41	S27	K27
SIR 2000 U27V-T10	27	2.0	2.32	14	1.31	0.41	S27	K27
SIR 2500 V27V-T10	27	2.5	2.85	16	1.51	0.41	S27	K27

For **LEFT HAND** toolholders specify **SIL** instead of **SIR**

* To be compare with given minimum bore profile.

Gang Toolholders

Gang Toolholders are External Holders, used in small automatic machines with a gangtool post.

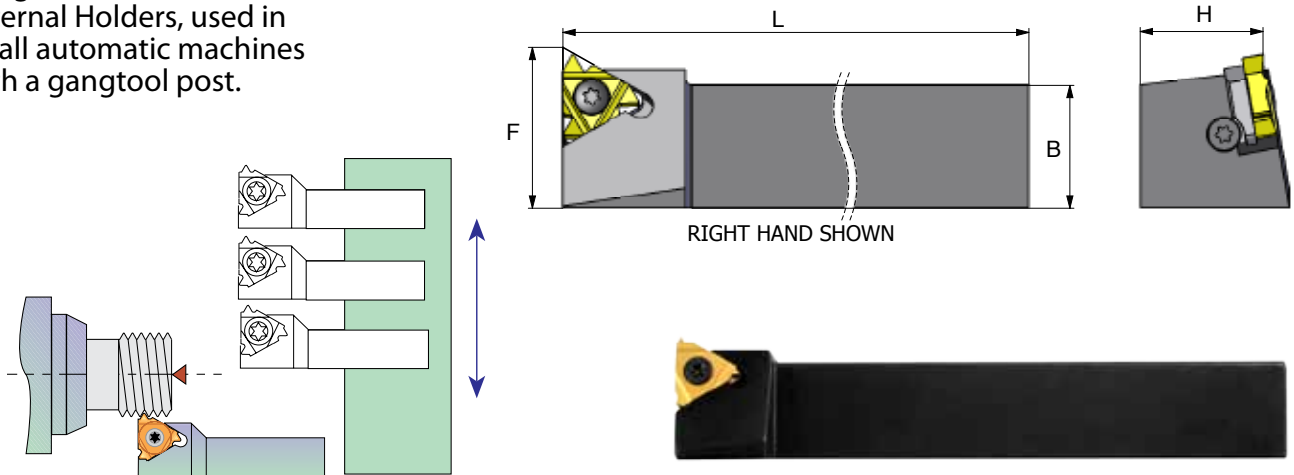

Ordering Code Right Hand	L mm	B=H mm	L mm	F mm	Insert Screw	Anvil Screw	Torx Key	RH Anvil	LH Anvil
*SER 8 8 H11G	11	8	100	12.0	S11	-	K11	-	-
*SER 10 10 H11G	11	10	100	14.0	S11	-	K11	-	-
SER 16 16 K16G	16	16	125	21.7	S16	A16	K16	AE16	AI16
SER 20 20 K16G	16	20	125	26.2	S16	A16	K16	AE16	AI16

*Toolholders with no anvil

For **LEFT HAND** toolholders specify **SEL** instead of **SER**

Quick Change Polygon Threading Toolholders

- Polygon shank
- ISO standard (26623) compliant for toolholding systems
- Polygon taper ensures automatic radial centering and even pressure around the coupling
- Enable quick tool changes ISO standard coupling system with a 1.4 degree tapered polygon shank design
- Interchangeable with leading manufacturers

External Toolholders

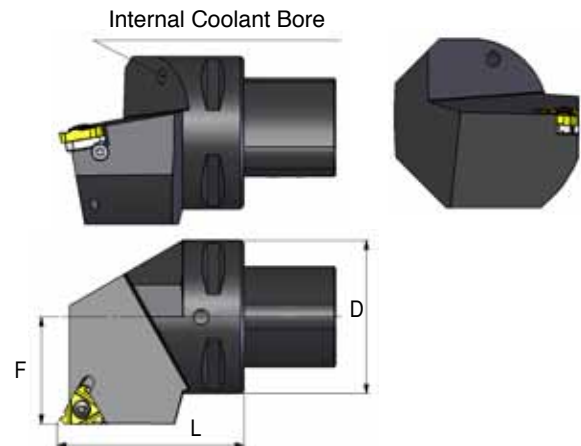

Equivalent to...	Ordering Code		D	F	L	Insert Screw	Anvil Screw	Torx key	RH Anvil	LH Anvil
C4	P40-SER 27050-16	16	1.575	1.063	1.969	S16	A16	K16	AE16	AI16
C5	P50-SER 35060-16	16	1.969	1.378	2.362	S16	A16	K16	AE16	AI16
C6	P63-SER 45065-16	16	2.480	1.772	2.559	S16	A16	K16	AE16	AI16
C4	P40-SER 27050-22	22	1.575	1.063	1.969	S22	A22	K22	AE22	AI22
C5	P50-SER 35060-22	22	1.969	1.378	2.362	S22	A22	K22	AE22	AI22
C6	P63-SER 45065-22	22	2.480	1.772	2.559	S22	A22	K22	AE22	AI22
C8	P80-SER 55080-22	22	3.150	2.165	3.150	S22	A22	K22	AE22	AI22

For **LEFT HAND** toolholders specify **SEL** instead of **SER**

Internal Toolholders

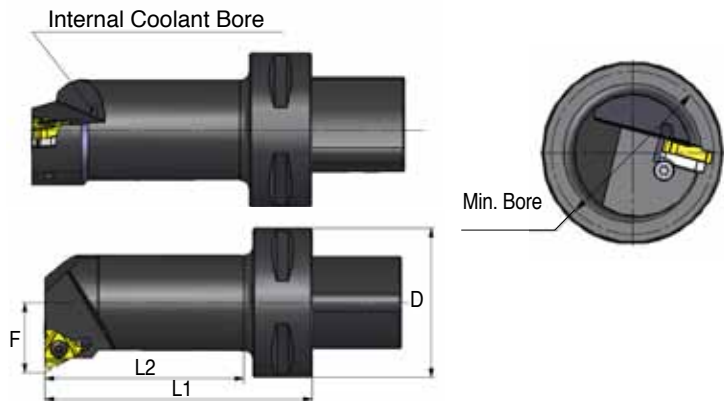



Equivalent to...	Ordering Code		D	F	Min. Bore Dia.	L1	L2	Insert Screw	Anvil Screw	Torx key	RH Anvil	LH Anvil
C4	* P40-SIR 12060-16	16	1.575	0.461	0.787	2.362	1.457	S16	-	K16	-	-
	P40-SIR 14060-16	16	1.575	0.531	0.984	2.362	1.496	S16	A16	K16	AI16	AE16
	P40-SIR 17070-16	16	1.575	0.630	1.142	2.756	1.890	S16	A16	K16	AI16	AE16
	P40-SIR 22090-16	16	1.575	0.768	1.417	3.543	2.717	S16	A16	K16	AI16	AE16
	P40-SIR 27080-16	16	1.575	0.925	1.732	3.150	2.362	S16	A16	K16	AI16	AE16
C5	* P50-SIR 12060-16	16	1.969	0.461	0.787	2.362	1.378	S16	-	K16	-	-
	P50-SIR 14060-16	16	1.969	0.531	0.984	2.362	1.417	S16	A16	K16	AI16	AE16
	P50-SIR 17070-16	16	1.969	0.630	1.142	2.756	1.850	S16	A16	K16	AI16	AE16
	P50-SIR 22090-16	16	1.969	0.768	1.417	3.543	2.677	S16	A16	K16	AI16	AE16
	P50-SIR 27105-16	16	1.969	0.925	1.732	4.134	3.307	S16	A16	K16	AI16	AE16
C6	P63-SIR 14070-16	16	2.480	0.531	0.984	2.756	1.654	S16	A16	K16	AI16	AE16
	P63-SIR 17075-16	16	2.480	0.630	1.142	2.953	1.890	S16	A16	K16	AI16	AE16
	P63-SIR 22090-16	16	2.480	0.768	1.417	3.543	2.520	S16	A16	K16	AI16	AE16
	P63-SIR 27105-16	16	2.480	0.925	1.732	4.134	3.150	S16	A16	K16	AI16	AE16
C4	* P40-SIR 15065-22	22	1.575	0.606	0.984	2.559	1.654	S22	-	K22	-	-
	P40-SIR 19070-22	22	1.575	0.705	1.142	2.756	1.890	S22	A22	K22	AI22	AE22
	P40-SIR 22090-22	22	1.575	0.843	1.496	3.543	2.717	S22	A22	K22	AI22	AE22
	P40-SIR 27080-22	22	1.575	1.000	1.811	3.150	2.362	S22	A22	K22	AI22	AE22
C5	* P50-SIR 15065-22	22	1.969	0.606	0.984	2.559	1.614	S22	-	K22	-	-
	P50-SIR 19070-22	22	1.969	0.705	1.142	2.756	1.850	S22	A22	K22	AI22	AE22
	P50-SIR 22090-22	22	1.969	0.843	1.496	3.543	2.677	S22	A22	K22	AI22	AE22
	P50-SIR 27105-22	22	1.969	1.000	1.811	4.134	3.307	S22	A22	K22	AI22	AE22
C6	P63-SIR 19075-22	22	2.480	0.705	1.142	2.953	1.890	S22	A22	K22	AI22	AE22
	P63-SIR 22090-22	22	2.480	0.843	1.496	3.543	2.520	S22	A22	K22	AI22	AE22
	P63-SIR 27105-22	22	2.480	1.000	1.811	4.134	3.150	S22	A22	K22	AI22	AE22

For **LEFT HAND** toolholders specify **SIL** instead of **SIR**

* Holders without anvil

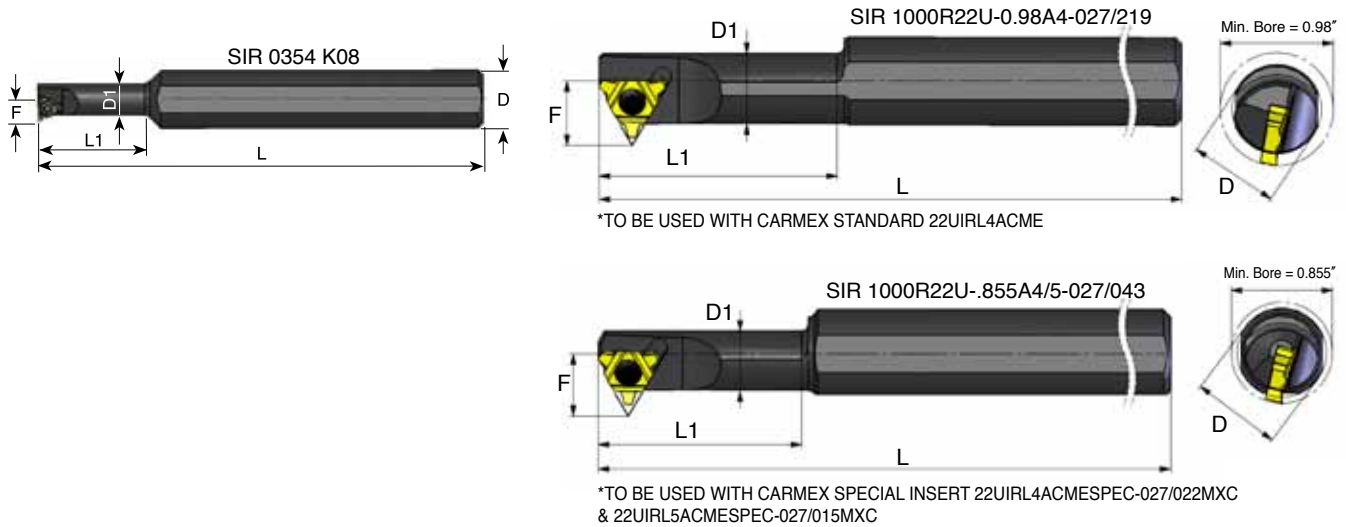
Special Thread Turning Applications



Ordering Code Right Hand		D	D1	L	L1	F	Thread	Insert Screw	Torx Key
*SIR 0354 K08	8	0.63	0.34	5	1.18	0.25	1/2 - 13UNC	S08	K08
SIR 1000 R22U-0.98A4-027/219	22U	1.00	0.79	8	2.75	0.72	—	S22	K22
SIR 1000 R22U-855A4/5-027/043	22U	1.00	0.67	8	2.00	0.70	—	S22	K22

For LH holders call Carmex
* Only right hand available

Large Profile Range

- Pitch Range: 14mm up to 24 mm.
- Tools and inserts are offered as specials (non catalog), because each holder has to be modified to fit the profile shape.
- Rigid Clamping.

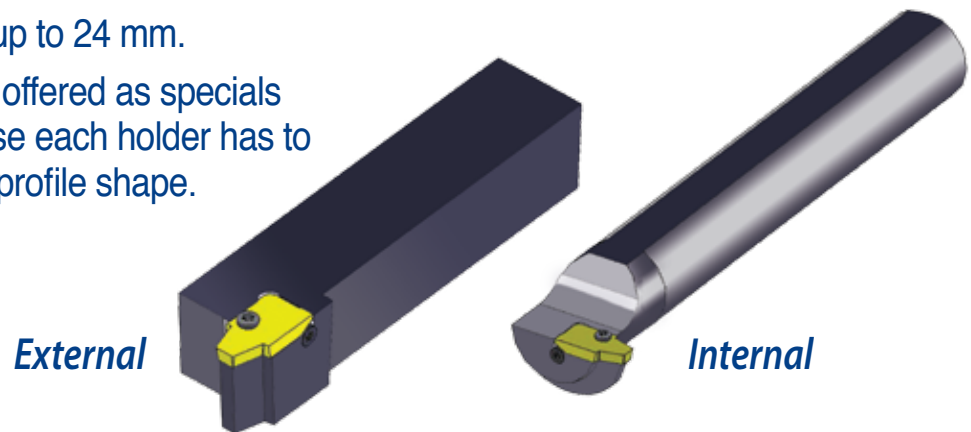

- Tailor made profiles according to customer's request

Available Profile	Round (DIN 20400)	Trapez (DIN 103)	Acme, Stub Acme	American Buttress
Pitch	16 mm	14-24 mm	1.0 - 1.5 TPI	1.5 - 2.0 TPI

Thread Helix Angle

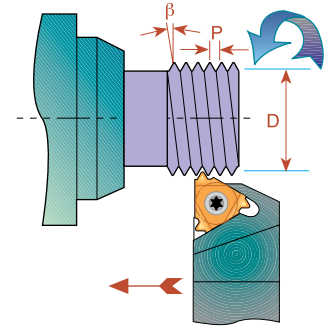
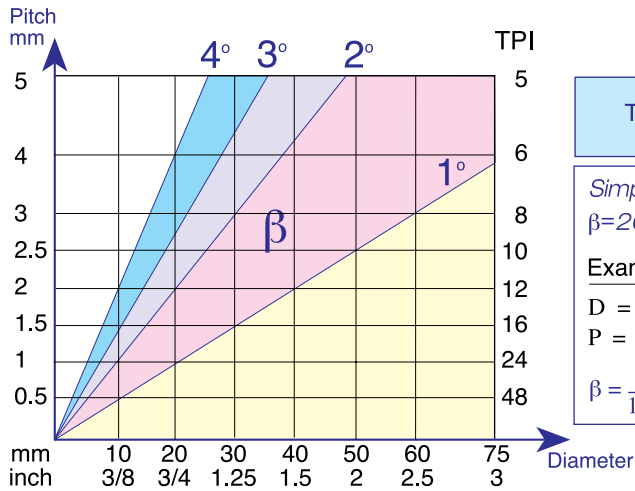

Standard and Slanted Anvils

CARMEX Toolholder Pockets have a built in 1.5° helix angle. This angle may be adjusted to better match the thread helix angle by simply changing the anvil.

Negative helix is usually used when threading RH thread with LH Holder or LH thread with RH Holder.

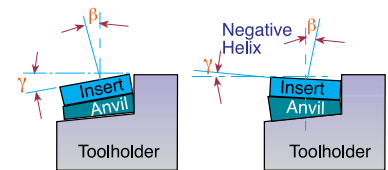

L mm	IC	Pocket Angle γ	4.5°	3.5°	2.5°	1.5° Standard	0.5°	-0.5°	-1.5°
16	3/8	EX-RH OR IN-LH	AE16+4.5	AE16+3.5	AE16+2.5	AE16	AE16+0.5	AE16-0.5	AE16-1.5
16	3/8	EX-LH OR IN-RH	AI 16+4.5	AI 16+3.5	AI 16+2.5	AI 16	AI 16+0.5	AI 16-0.5	AI 16-1.5
22	1/2	EX-RH OR IN-LH	AE22+4.5	AE22+3.5	AE22+2.5	AE22	AE22+0.5	AE22-0.5	AE22-1.5
22	1/2	EX-LH OR IN-RH	AI 22+4.5	AI 22+3.5	AI 22+2.5	AI 22	AI 22+0.5	AI 22-0.5	AI 22-1.5
22U	1/2U	EX-RH OR IN-LH	AE22U+4.5	AE22U+3.5	AE22U+2.5	AE22U	AE22U+0.5	AE22U-0.5	AE22U-1.5
22U	1/2U	EX-LH OR IN-RH	AI 22U+4.5	AI 22U+3.5	AI 22U+2.5	AI 22U	AI 22U+0.5	AI 22U-0.5	AI 22U-1.5
27	5/8	EX-RH OR IN-LH	AE27+4.5	AE27+3.5	AE27+2.5	AE27	AE27+0.5	AE27-0.5	AE27-1.5
27	5/8	EX-LH OR IN-RH	AI 27+4.5	AI 27+3.5	AI 27+2.5	AI 27	AI 27+0.5	AI 27-0.5	AI 27-1.5
27U	5/8U	EX-RH OR IN-LH	AE27U+4.5	AE27U+3.5	AE27U+2.5	AE27U	AE27U+0.5	AE27U-0.5	AE27U-1.5
27U	5/8U	EX-LH OR IN-RH	AI 27U+4.5	AI 27U+3.5	AI 27U+2.5	AI 27U	AI 27U+0.5	AI 27U-0.5	AI 27U-1.5

Anvil Kits

5 AE and 5 AI anvils with various helix angles



AE (FOR EX.RH. & IN.LH.)



AI (FOR IN.RH. & EX.LH.)



Ordering Code	Contents				
KA16	AE16+4.5 AI 16+4.5	AE16+3.5 AI 16+3.5	AE16+2.5 AI 16+2.5	AE16+0.5 AI 16+0.5	AE16-1.5 AI 16-1.5
KA22	AE22+4.5 AI 22+4.5	AE22+3.5 AI 22+3.5	AE22+2.5 AI 22+2.5	AE22+0.5 AI 22+0.5	AE22-1.5 AI 22-1.5
KA22U	AE22U+4.5 AI 22U+4.5	AE22U+3.5 AI 22U+3.5	AE22U+2.5 AI 22U+2.5	AE22U+0.5 AI 22U+0.5	AE22U-1.5 AI 22U-1.5
KA27	AE27+4.5 AI 27+4.5		AE27+2.5 AI 27+2.5		AE27-1.5 AI 27-1.5
KA27U	AE27U+4.5 AI 27U+4.5		AE27U+2.5 AI 27U+2.5		AE27U-1.5 AI 27U-1.5

Standard Kits

Threading Kits are a versatile solution for users that cut a variety of thread types in limited quantity and do not want to sacrifice thread quality.

External UN Kit Ordering Code:KEU

INSERTS

16 ER A60 P25C
 16 ER G60 P25C
 16 ER AG60 P25C
 16 ER 8 UN P25C
 16 ER 12 UN P25C
 16 ER 14 UN P25C
 16 ER 16 UN P25C
 16 ER 18 UN P25C
 16 ER 20 UN P25C
 16 ER 24 UN P25C

TOOLHOLDERS

SER 0750 K16
 KEY
 K16
 SCREW
 S16

Internal UN Kit Ordering Code:KIU

INSERTS

16 IR A60 P25C
 16 IR G60 P25C
 16 IR AG60 P25C
 16 IR 8 UN P25C
 16 IR 12 UN P25C
 16 IR 14 UN P25C
 16 IR 16 UN P25C
 16 IR 18 UN P25C
 16 IR 20 UN P25C
 16 IR 24 UN P25C

TOOLHOLDERS

SIR 0750 P16
 KEY
 K16
 SCREW
 S16



If a larger toolholders with a 1.0 inch shank is required, add to the kit 1.0. For example: KIU - 1.0

Miniature & Ultra-miniature Kits



Ordering Code	Type	No. of Inserts	Inserts	Contents Boring Bar	Key
KU60I - BXC	ULTRA	10	06 IR A60 BXC	SIR 0205 H06	K6
KM60I - BXC	MINI	10	08 IR A60 BXC	SIR 0265 K08	K8

Inserts' Kits

Type B Kits

Type B threading inserts.
A combination of ground profile and sintered chip-breaker threading inserts.
BMA Grade: Sub-Micron carbide grade with TiAlN multi-Layer Coating.

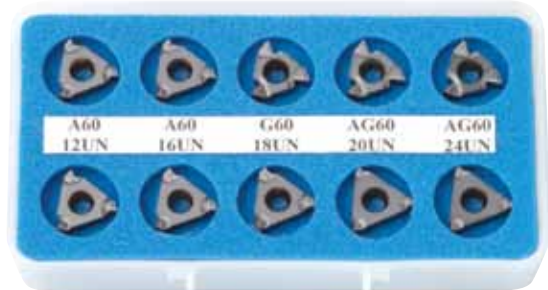

EXTERNAL UN KIT KEUB - BMA

- 16 ER B A60 BMA-2 Pcs
- 16 ER B G60 BMA-1 Pcs
- 16 ER B AG60 BMA-2 Pcs
- 16 ER B 12 UN BMA-1 Pcs
- 16 ER B 16 UN BMA-1 Pcs
- 16 ER B 18 UN BMA-1 Pcs
- 16 ER B 20 UN BMA-1 Pcs
- 16 ER B 24 UN BMA-1 Pcs



EX-RH

INTERNAL UN KIT KIUB - BMA

- 16 IR B A60 BMA-2 Pcs
- 16 IR B G60 BMA-1 Pcs
- 16 IR B AG60 BMA-2 Pcs
- 16 IR B 12 UN BMA-1 Pcs
- 16 IR B 16 UN BMA-1 Pcs
- 16 IR B 18 UN BMA-1 Pcs
- 16 IR B 20 UN BMA-1 Pcs
- 16 IR B 24 UN BMA-1 Pcs



IN-RH

Standard Inserts' Kits

EXTERNAL ISO KIT

- 16 ER 1.0 ISO-2 Pcs
- 16 ER 1.25 ISO-2 Pcs
- 16 ER 1.5 ISO-2 Pcs
- 16 ER 1.75 ISO-2 Pcs
- 16 ER 2.0 ISO-2 Pcs

INTERNAL ISO KIT

- 16 IR 1.0 ISO-2 Pcs
- 16 IR 1.25 ISO-2 Pcs
- 16 IR 1.5 ISO-2 Pcs
- 16 IR 1.75 ISO-2 Pcs
- 16 IR 2.0 ISO-2 Pcs

Ordering Code: KEM

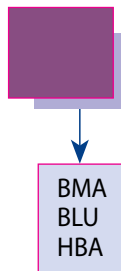

Ordering Code: KIM

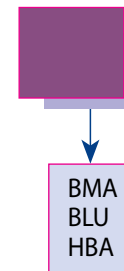

Threading & Boring Combination Kit

A practical and convenient combination kit for **Ultra Miniature** Threading and Boring. It enables Boring and Threading of mini bores as small as **1/4" diameter** with just one deep reaching CARBIDE shank ultra mini Boring Bar.



Ordering Code	Contents			Key
	Threading Insert	Turning Inserts	Boring Bar	
KC6TI	06 IR A60 BXC 10Pcs	06 IR TURN BMA 10Pcs	SIR 0205 H06CB	K6

BMA - Coated carbide grade for medium to high cutting speeds

BXC - Coated carbide grade for low cutting speed - 130 to 300 ft/min

CB - Carbide shank boring bar with coolant bore



Double Sided Thread Turning Inserts



A unique line of 2 sided inserts including 6 cutting edges, a cost saving tool.

Advantages of DSI-Thread Turning Inserts

- Increased productivity thanks to the six cutting edges.
- U Style inserts for a wide range of full or partial profile standard threads.
- Same insert for right hand or left hand thread.
- Saving on tooling costs.
- Unique anti-vibration anvil design for clamping the insert and supporting the cutting edge.
- Simple insert's mounting and cutting edge indexing.
- Heavy duty toolholders designed specially for this line.

Contents:

Page:

Product Identification	60
Partial Profile 60°	61
Partial Profile 55°	61
ISO	62
UN	62
WHITWORTH 55°	63
NPT	63
Thread Turning Toolholder - External	64
Thread Turning Toolholder - Internal	64

Product Identification

DSI Ordering Code

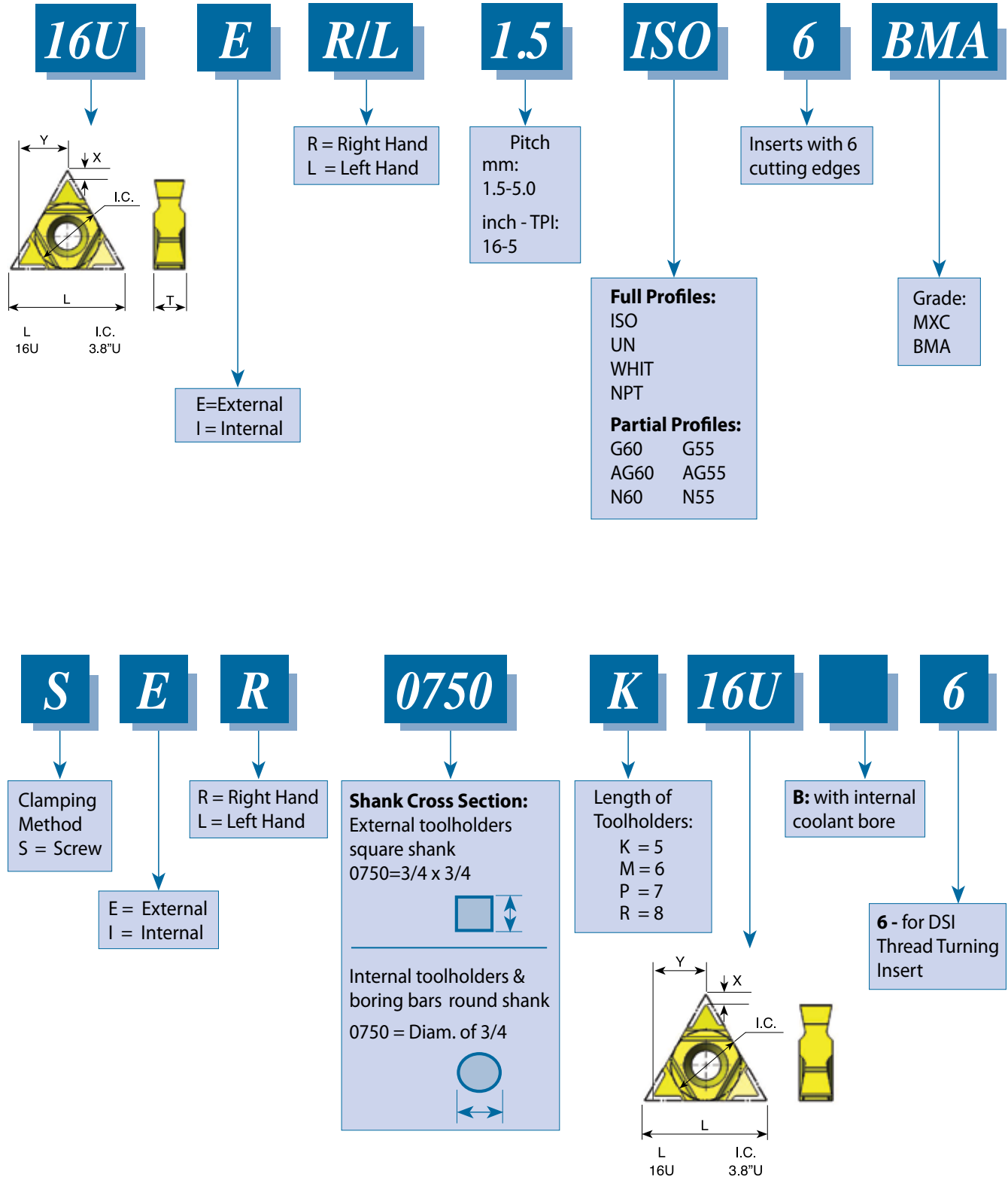

Partial Profile 60°

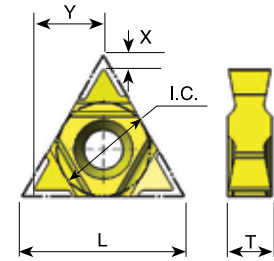

Pitch Range mm	Pitch Range TPI	L mm	I.C.	EXTERNAL Ordering Code	INTERNAL Ordering Code	X	Y	T
1.75 - 3.0	14-8	16U	3/8U	16U ER/L G60-6	16U IR/L G60-6	.06	.28	.18
0.5 - 3.0	48-8	16U	3/8U	16U ER/L AG60-6	16U IR/L AG60-6	.06	.28	.18
3.5 - 5.0	7-5	16U	3/8U	16U ER/L N60-6	16U IR/L N60-6	.05	.29	.18

Available coating grades: BMA or MXC

Partial Profile 55°

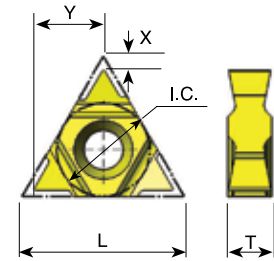

Pitch Range mm	Pitch Range TPI	L mm	I.C.	EXTERNAL Ordering Code	INTERNAL Ordering Code	X	Y	T
1.75 - 3.0	14-8	16U	3/8U	16U ER/L G55-6	16U IR/L G55-6	.06	.28	.18
0.5 - 3.0	48-8	16U	3/8U	16U ER/L AG55-6	16U IR/L AG55-6	.06	.28	.18
3.5 - 5.0	7-5	16U	3/8U	16U ER/L N55-6	16U IR/L N55-6	.05	.29	.18

Available coating grades: BMA or MXC

For Carbide Grade and Cutting Speed see page 66-67

ISO

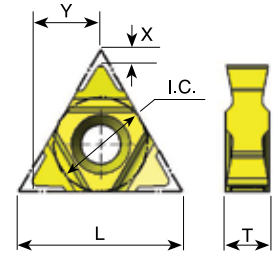

Pitch mm	L mm	I.C.	EXTERNAL Ordering Code	INTERNAL Ordering Code	X	Y	T
1.5	16U	3/8U	16U ER/L 1.5 ISO-6	16U IR/L 1.5 ISO-6	.06	.27	.18
1.75	16U	3/8U	16U ER/L 1.75 ISO-6	16U IR/L 1.75 ISO-6	.06	.27	.18
2.0	16U	3/8U	16U ER/L 2.0 ISO-6	16U IR/L 2.0 ISO-6	.06	.27	.18
2.5	16U	3/8U	16U ER/L 2.5 ISO-6	16U IR/L 2.5 ISO-6	.06	.27	.18
3.0	16U	3/8U	16U ER/L 3.0 ISO-6	16U IR/L 3.0 ISO-6	.06	.27	.18
3.5	16U	3/8U	16U ER/L 3.5 ISO-6	16U IR/L 3.5 ISO-6	.06	.27	.18
4.0	16U	3/8U	16U ER/L 4.0 ISO-6	16U IR/L 4.0 ISO-6	.06	.27	.18
4.5	16U	3/8U	16U ER/L 4.5 ISO-6	16U IR/L 4.5 ISO-6	.06	.27	.18
5.0	16U	3/8U	16U ER/L 5.0 ISO-6	16U IR/L 5.0 ISO-6	.06	.27	.18

Available coating grades: BMA or MXC

UN - Unified **UNC, UNF, UNEF, UNS**

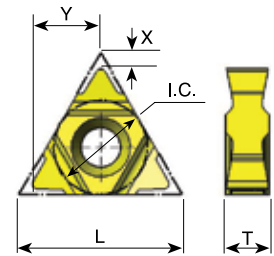

Pitch TPI	L mm	I.C.	EXTERNAL Ordering Code	INTERNAL Ordering Code	X	Y	T
16	16U	3/8U	16U ER/L 16 UN-6	16U IR/L 16 UN-6	.06	.27	.18
14	16U	3/8U	16U ER/L 14 UN-6	16U IR/L 14 UN-6	.06	.27	.18
13	16U	3/8U	16U ER/L 13 UN-6	16U IR/L 13 UN-6	.06	.27	.18
12	16U	3/8U	16U ER/L 12 UN-6	16U IR/L 12 UN-6	.06	.27	.18
11.5	16U	3/8U	16U ER/L 11.5 UN-6	16U IR/L 11.5 UN-6	.06	.27	.18
11	16U	3/8U	16U ER/L 11 UN-6	16U IR/L 11 UN-6	.06	.27	.18
10	16U	3/8U	16U ER/L 10 UN-6	16U IR/L 10 UN-6	.06	.27	.18
9	16U	3/8U	16U ER/L 9 UN-6	16U IR/L 9 UN-6	.06	.27	.18
8	16U	3/8U	16U ER/L 8 UN-6	16U IR/L 8 UN-6	.06	.27	.18
7	16U	3/8U	16U ER/L 7 UN-6	16U IR/L 7 UN-6	.06	.27	.18
6	16U	3/8U	16U ER/L 6 UN-6	16U IR/L 6 UN-6	.06	.27	.18
5	16U	3/8U	16U ER/L 5 UN-6	16U IR/L 5 UN-6	.06	.27	.18

Available coating grades: BMA or MXC

For Carbide Grade and Cutting Speed see page 66-67

Whitworth 55° BSW, BSF, BSP, BSB

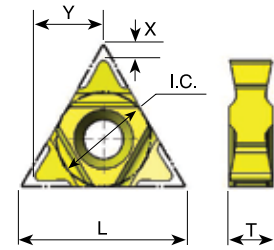

Pitch TPI	L mm	I.C.	EXTERNAL Ordering Code	INTERNAL Ordering Code	X	Y	T
16	16U	3/8U	16U ER/L 16 W-6	16U IR/L 16 W-6	.06	.27	.18
14	16U	3/8U	16U ER/L 14 W-6	16U IR/L 14 W-6	.06	.27	.18
12	16U	3/8U	16U ER/L 12 W-6	16U IR/L 12 W-6	.06	.27	.18
11	16U	3/8U	16U ER/L 11 W-6	16U IR/L 11 W-6	.06	.27	.18
10	16U	3/8U	16U ER/L 10 W-6	16U IR/L 10 W-6	.06	.27	.18
9	16U	3/8U	16U ER/L 9 W-6	16U IR/L 9 W-6	.06	.27	.18
8	16U	3/8U	16U ER/L 8 W-6	16U IR/L 8 W-6	.06	.27	.18
7	16U	3/8U	16U ER/L 7 W-6	16U IR/L 7 W-6	.06	.27	.18
6	16U	3/8U	16U ER/L 6 W-6	16U IR/L 6 W-6	.06	.27	.18
5	16U	3/8U	16U ER/L 5 W-6	16U IR/L 5 W-6	.06	.27	.18

Available coating grades: BMA or MXC

NPT

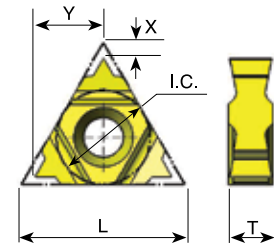

Pitch TPI	L mm	I.C.	EXTERNAL Ordering Code	INTERNAL Ordering Code	X	Y	T
14	16U	3/8U	16U ER/L 14 NPT-6	16U IR/L 14 NPT-6	.06	.27	.18
11.5	16U	3/8U	16U ER/L 11.5 NPT-6	16U IR/L 11.5 NPT-6	.06	.27	.18
8	16U	3/8U	16U ER/L 8 NPT-6	16U IR/L 8 NPT-6	.06	.27	.18

Available coating grades: BMA or MXC
For Carbide Grade and Cutting Speed see page 66-67

Heavy Duty Thread Turning Toolholders

External

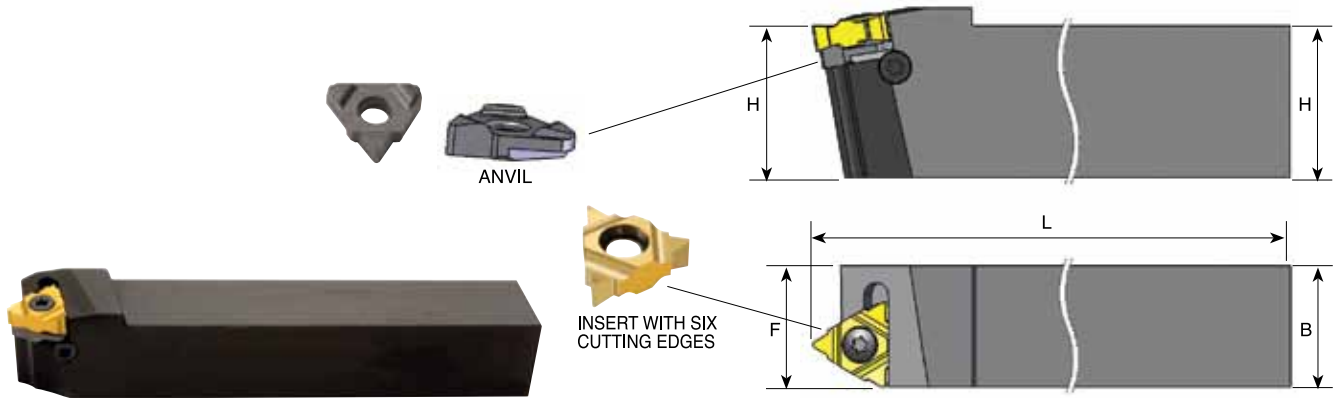

Ordering Code Right Hand	H	B	L	F	Insert Screw	Anvil Screw	Torx Key	RH Anvil	LH Anvil
SER 0750 K16U-6	0.75	0.75	5	0.75	S16	A16	K16	AER 16U-6	AEL 16U-6
SER 1079 M16U-6	1.0	0.79	6	0.79	S16	A16	K16	AER 16U-6	AEL 16U-6

For **LEFT HAND** toolholders specify **SEL** instead of **SER**

Internal with Coolant Bore

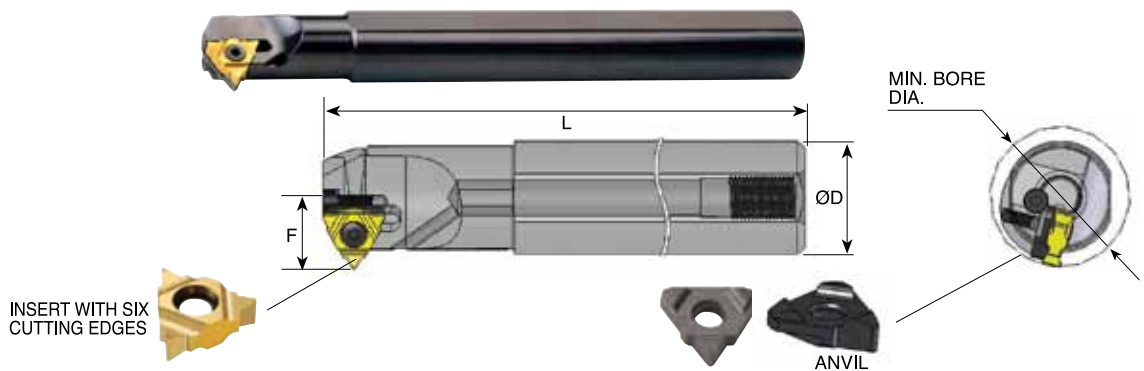

Ordering Code Right Hand	ØD	Min. bore dia.	L	F	Insert Screw	Anvil Screw	Torx Key	RH Anvil	LH Anvil
SIR 0750 P16UB-6	0.75	0.94	7	0.57	S16	A16	K16	AIR 16U-6	AIL 16U-6
SIR 1000 R16UB-6	1.0	1.14	8	0.69	S16	A16	K16	AIR 16U-6	AIL 16U-6

For **LEFT HAND** toolholders specify **SIL** instead of **SIR**

Thread Turning Technical Section

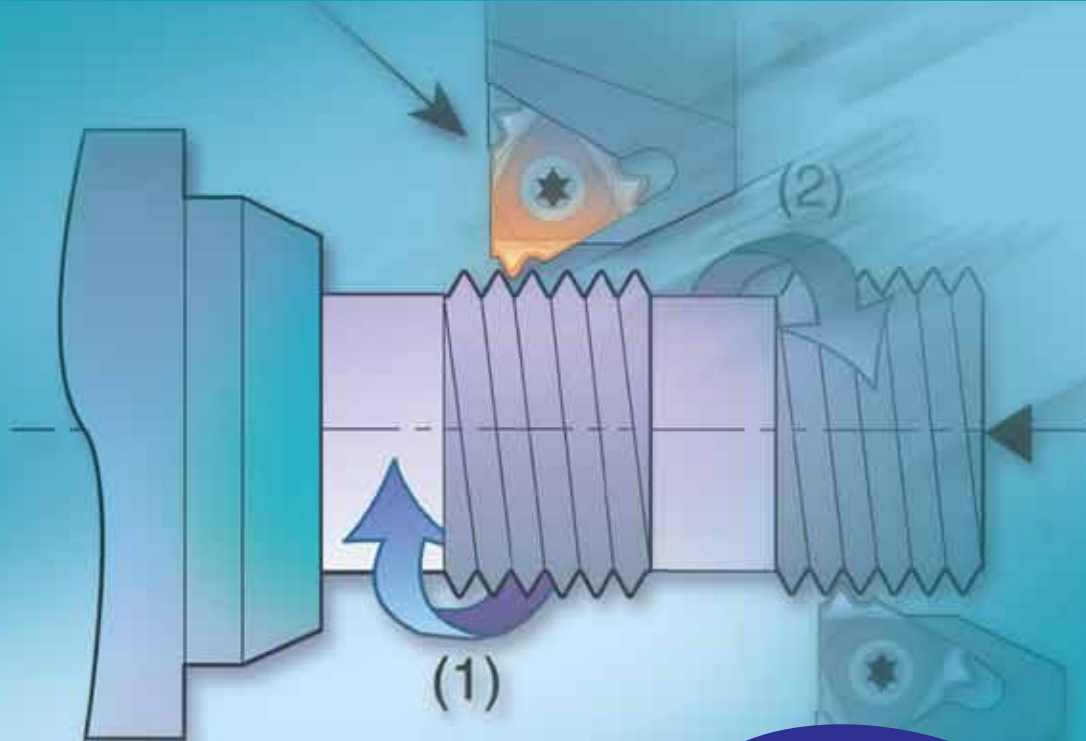

Thread Turning Catalog and CNC Programming Software



Contents:	Page:	Contents:	Page:
Carbide Grade Selection	66	Anvil Change Recommendation	71
Type B inserts	66	Thread Turning Step by Step	72
Recommended Cutting Speed	67	Troubleshooting	73
Conversion of Cutting Speed to Rotational Speed	68	Threading Inserts Standards	74
Number of Threading Passes Selection	68		
Number of Threading Passes Selection for Single Point Inserts	69		
Thread Turning Methods	69		
Important Points about Carmex Threading Inserts	70		
Flank Clearance Angle	70		

Carbide Grade Selection

Choose the Carmex grade specifically formulated for your application from the following list:

Coated Grades

HBA
(H10-H25)
(S10-S25) Extra-fine sub-micron grade with high toughness, for optimized performance on hardened steels and cast iron up to 62HRC, titanium alloys and super alloys (hastelloy, inconel and nickel based alloys).

BLU
(M10-M20)
(K05-K20)
(N10-N20)
(S10-S20) PVD triple layer coated sub-micron grade for stainless steels, cast iron, titanium, non ferrous metals and most of the high temperature alloys.

BMA
(P20-P40)
(K20-K30) PVD TiAlN coated sub-micrograin grade for stainless steels and exotic materials at medium to high cutting speeds.

P25C
(P15-P35) PVD TiN coated grade for treated and hard alloy steels (25 HRc & up) at medium to low cutting speeds.

MXC
(K10-K20)
(P10-P25) PVD TiN coated micrograin for free cutting untreated alloy steels (below 30 HRc), for stainless steels and cast iron.

BXC
(P30-P50)
(K25-K40) PVD TiN coated grade for low cutting speed. Works well with wide range of stainless steels.

Uncoated Grades

P30*
(P20-P30) Carbide grade for carbon and cast steels, works well at medium to low cutting speeds.

K20*
(K10-K30) Carbide grade for non ferrous metals, aluminum and cast iron.

* Upon request

Note: Due to our unique and specialized production techniques, Carmex coated inserts provide superior cutting performance and exceptionally long tool life.

Grade availability per inserts size

Grade	HBA	BLU	BMA	P25C	MXC	BXC	P30	K20
Insert sizes	11, 16, 22, 27	11, 16, 22	06, 08, 11, 16, 22, 27, 33U, Type-B 11, 16	11, 16, 22, 27, 33U	11, 16, 22, 27, 33U	06, 08	11, 16, 22, 27, 33U	06, 08, 11, 16, 22, 27, 33U

Type B - Threading Inserts

A combination of ground profile, and sintered chip-breaker threading inserts. Unlike most other manufacturers inserts, this combination ensures a consistent high quality thread, with precise shape and dimensions. Two different unique styles of chip-breaker were designed to suit the different specific requirements of Internal threads and External threads. All of Carmex Type B inserts are made of BMA Sub-Micrograin grade.



Recommended cutting speed (ft/min) for thread turning inserts

ISO Standard	Material		Condition								
				HBA	BLU	BMA	P25C	MXC	BXC	K20	P30
P	Non-Alloy Steel and Cast Steel, Free Cutting Steel	<0.25%C	Annealed	360-690	390-590	330-590	390-590	230-490	165-425		
		≥0.25%C	Annealed								
		<0.55%C	Quenched & Tempered								
		≥0.55%C	Annealed								
			Quenched & Tempered								
	Low Alloy Steel and Cast Steel (less than 5% alloying elements)	Annealed Quenched & Tempered	295-460	260-425	230-394	230-390	195-295	165-260			
	High Alloy Steel, Cast Steel, and Tool Steel	Annealed Quenched & Tempered	230-295	195-260	165-195	180-230	165-195	130-165			
M	Stainless Steel and Cast Steel	Ferritic / Martensitic	360-525	295-425	195-295	195-295	165-260	165-260			
		Martensitic									
		Austenitic									
K	Cast Iron Nodular (GGG)	Ferritic / Pearlitic	390-490	330-425	260-360	195-295					
		Pearlitic									
	Grey Cast Iron (GG)	Ferritic	460-490	395-425	395-330	215-280					
		Pearlitic									
	Malleable Cast Iron	Ferritic	360-460	330-425	260-330	195-280					
		Pearlitic									
N	Aluminum-Wrought Alloy		Not Cureable	2300-3280	1970-2620	1480-1970	1970-2620	1150-1640			
			Cured								
	Aluminum-Cast, Alloyed	<=12% Si	Not Cureable	920-2460	650-1800	490-1150	660-1800	360-985			
			Cured								
	Copper Alloys	>12% Si	High Temperature	625-1150	490-820	360-590	490-820	295-490			
			Free Cutting								
			Brass								
		Electrolytic Copper									
Non Metallic		Duroplastics, Fiber Plastics	655-985	490-690	330-655	360-490					
		Hard Rubber									
S	High Temp. Alloys, Super Alloys	Fe based	Annealed	65-260	100-215	80-195					
			Cured								
		Ni or Co based	Annealed								
			Cured								
		Cast									
Titanium Alloys		Alpha +Beta Alloys Cured	100-195	130-165	115-145	115-145					
H	Hardened Steel		Hardened 45-50 HRc	100-195	130-165	115-145					
			Hardened 51-55 HRc								
			Hardened 56-62 HRc								
	Chilled Cast Iron		Cast	65-165	100-130	80-115					
Cast Iron		Hardened	65-130	65-100	50-80						

Conversion of Cutting Speed to Rotational Speed

Conversion of a selected cutting speed to rotational speed is calculated by the following formula:

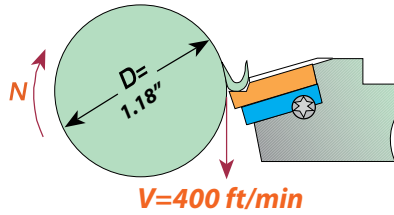

Example

$$N = \frac{V \times 12}{\pi \times D} = \frac{400 \times 12}{3.14 \times 1.18} = 1294 \text{ RPM}$$

Number of passes and depth of cut per pass for multitooth insert

	Pitch mm / TPI	Insert Size		No. of Teeth	Ordering Code	No. of Passes	Depth of Cut per pass			
		L (mm)	I.C.				1	2	3	4
ISO External	1.00	16	3/8	3	16 ER 1.0 ISO 3M	2	.015	.010		
	1.50	16	3/8	2	16 ER 1.5 ISO 2M	3	.017	.012	.008	
	1.50	22	1/2	3	22 ER 1.5 ISO 3M	2	.022	.015		
	2.00	22	1/2	2	22 ER 2.0 ISO 2M	3	.022	.016	.011	
	2.00	22	1/2	3	22 ER 2.0 ISO 3M	2	.030	.019		
ISO Internal	1.00	16	3/8	3	16 IR 1.0 ISO 3M	2	.013	.010		
	1.50	16	3/8	2	16 IR 1.5 ISO 2M	3	.015	.011	.008	
	1.50	22	1/2	3	22 IR 1.5 ISO 3M	2	.020	.015		
	2.00	22	1/2	2	22 IR 2.0 ISO 2M	3	.020	.014	.010	
	2.00	22	1/2	3	22 IR 2.0 ISO 3M	2	.028	.018		
UN External	16	16	3/8	2	16 ER 16 UN 2M	3	.017	.012	.009	
	16	22	1/2	3	22 ER 16 UN 3M	2	.023	.015		
	12	22	1/2	2	22 ER 12 UN 2M	3	.023	.017	.012	
	12	22	1/2	3	22 ER 12 UN 3M	2	.031	.020		
	8	27	5/8	2	27 ER 8 UN 2M	4	.024	.021	.018	.014
UN Internal	16	16	3/8	2	16 IR 16 UN 2M	3	.017	.011	.009	
	16	22	1/2	3	22 IR 16 UN 3M	2	.022	.015		
	12	22	1/2	2	22 IR 12 UN 2M	3	.021	.015	.012	
	12	22	1/2	3	22 IR 12 UN 3M	2	.029	.019		
	8	27	5/8	2	27 IR 8 UN 2M	4	.025	.020	.016	.012
Whitworth 55° External	14	16	3/8	2	16 ER 14 W 2M	3	.020	.015	.011	
	14	22	1/2	3	22 ER 14 W 3M	2	.028	.030		
	11	22	1/2	2	22 ER 11 W 2M	3	.026	.019	.013	
Whitworth 55° Internal	14	16	3/8	2	16 IR 14 W 2M	3	.020	.015	.011	
	14	22	1/2	3	22 IR 14 W 3M	2	.028	.018		
	11	22	1/2	2	22 IR 11 W 2M	2	.026	.019	.013	
NPT External	14	16	3/8	2	16 ER 14 NPT 2M	3	.021	.018	.017	
	11.5	22	1/2	2	22 ER 11.5 NPT 2M	4	.019	.019	.017	.013
	11.5	27	5/8	3	27 ER 11.5 NPT 3M	4	.020	.019	.017	.012
	8	27	5/8	2	27 ER 8 NPT 2M	4	.029	.026	.024	.021
NPT Internal	14	16	3/8	2	16 IR 14 NPT 2M	3	.021	.018	.017	
	11.5	22	1/2	2	22 IR 11.5 NPT 2M	4	.019	.019	.017	.013
	11.5	27	5/8	3	27 IR 11.5 NPT 3M	4	.020	.019	.017	.012
	8	27	5/8	2	27 IR 8 NPT 2M	4	.029	.026	.024	.021
API Round External	10	22	1/2	2	22 ER 10 APIRD 2M	3	.024	.020	.012	
	10	27	5/8	3	27 ER 10 APIRD 3M	2	.039	.016		
	8	27	5/8	2	27 ER 8 APIRD 2M	3	.031	.024	.016	
API Round Internal	10	22	1/2	2	22 IR 10 APIRD 2M	3	.024	.020	.012	
	10	27	5/8	3	27 IR 10 APIRD 3M	2	.039	.016		
	8	27	5/8	2	27 IR 8 APIRD 2M	3	.031	.024	.016	

Number of threading passes selection for single point inserts

Pitch:	mm TPI	0.5 48	0.8 32	1.0 24	1.25 20	1.5 16	1.75 14	2.0 12	2.5 10	3.0 8	4.0 6	6.0 4
Number of Passes		3-6	4-7	4-9	6-10	5-11	9-12	6-13	7-15	8-17	10-20	11-22

NOTES:

1. For most standard applications the middle of the range is a good starting point.
2. For most materials, the tougher the material, the higher the number of cutting passes you should select.
3. As a general rule of thumb, Fewer passes are better than more speed.

Thread Turning Methods

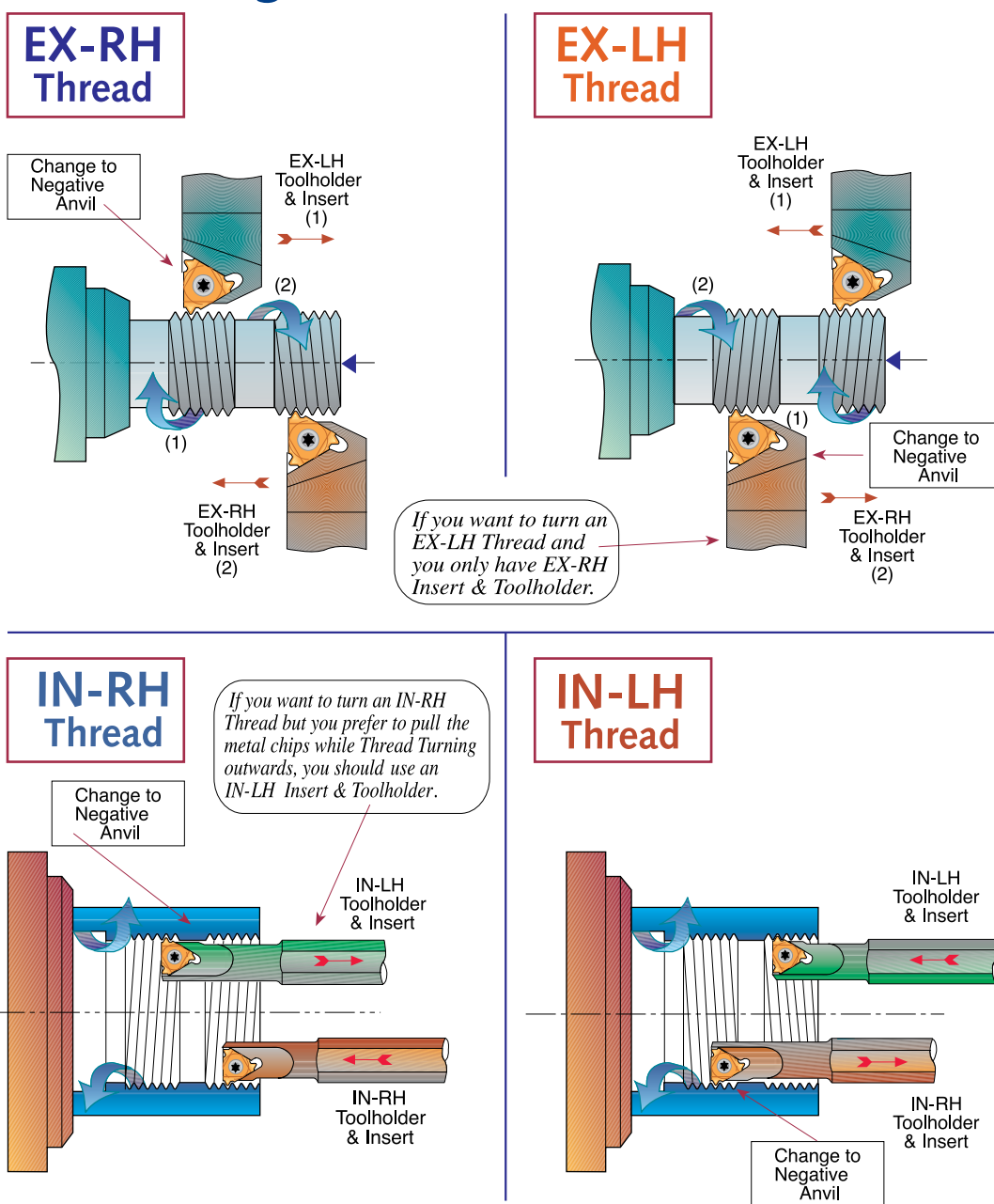

Important Points about Carmex Threading Inserts

1. In most thread forms internal and external threads have different depth and radii, thus tools are not interchangeable

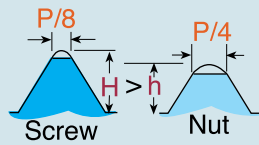

2. The Insert relief angle of a standard Carmex external toolholder is 10°; for an internal toolholder it is 15°. This 5° difference is to provide additional necessary radial clearance.

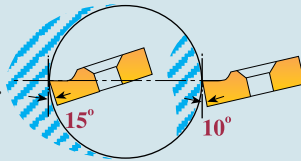

3. Our built-in relief angles ensure automatic insert flank angle clearance.

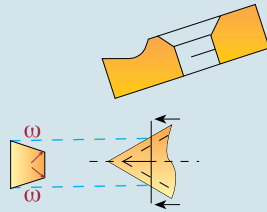

4. Profiles of Carmex internal & external threading inserts are precision ground to ensure accurate thread geometry when used in their corresponding toolholders. Using internal inserts with an external holder will result in distortion of angle and insert geometry.

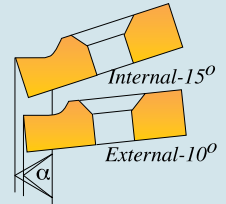

5. Insert and toolholder should always match. An IN-RH insert must be used with an IN-RH toolholder. No mismatch is allowed.



Flank Clearance Angle ω

$$\omega = \text{ArcTan}(\tan \alpha \times \tan \phi)$$

$\omega =$	$\omega =$	$\omega =$	$\omega =$	$\phi = 10^\circ$ for External toolholders
$\omega =$				$\phi = 15^\circ$ for Internal toolholders
 ISO, UN PARTIAL 60 NPT	 TRAPEZ ACME STACME	 AMERICAN BUTTRESS	 SAGE (DIN 513)	

Anvil Change Recommendation

As can be seen from the chart, some Pitch to Diameter combinations require an anvil change. If change is required, use AE anvils for EX-RH and IN-LH toolholders and AI anvils for IN-RH and EX-LH toolholders.

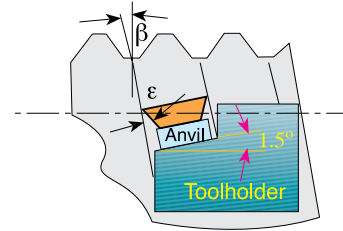
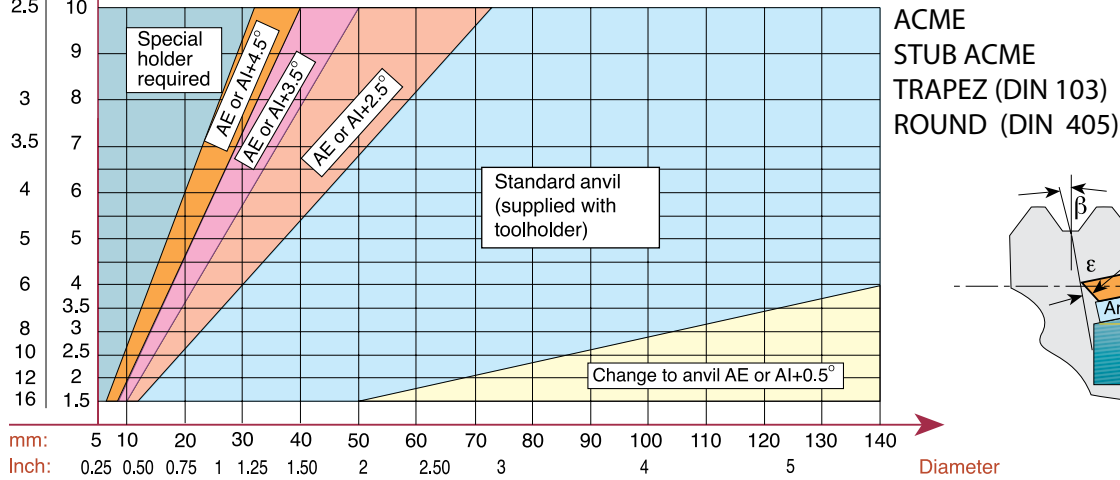

As can be seen from the chart, most applications do not require an anvil change. If change is required, use AE anvils for EX-RH and IN-LH toolholders and AI anvils for IN-RH and EX-LH toolholders.

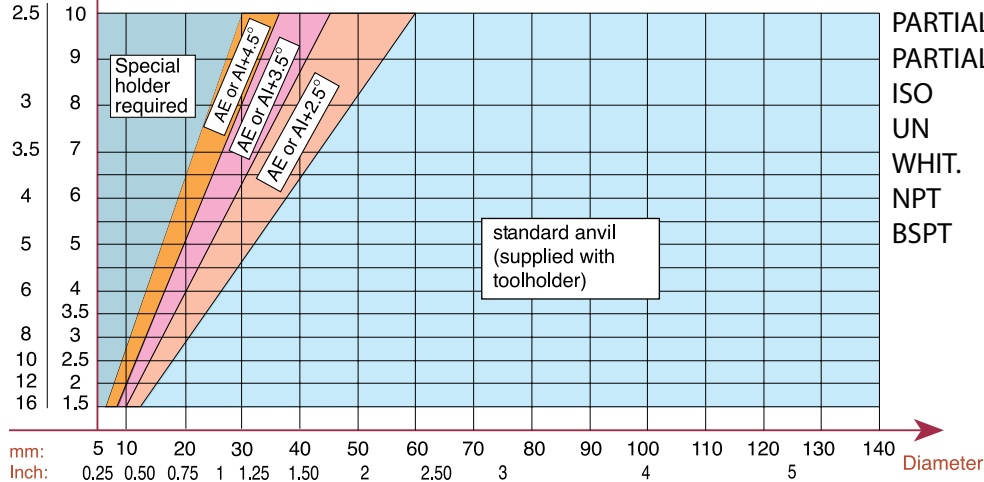

As can be seen from the chart, most applications require an anvil change. In most cases a negative anvil is required. Use AE anvils for EX-RH and IN-LH toolholders and AI anvils for IN-RH and EX-LH toolholders.

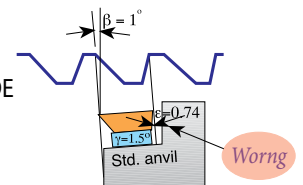
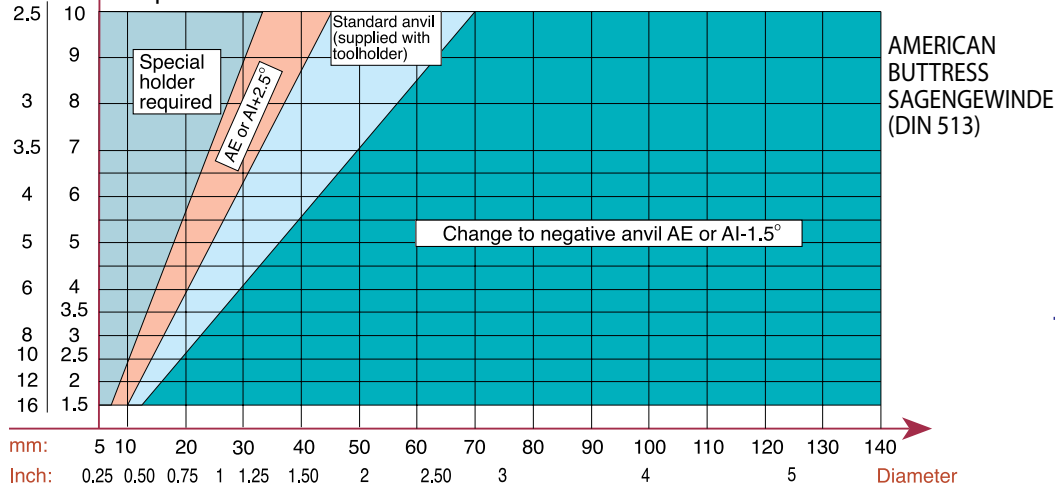

Replacing the standard anvil with an anvil with negative angle, will eliminate side rubbing

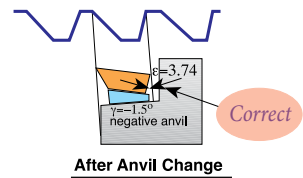

Thread Turning - Step by Step

Step 1 : Choose Thread Turning Method

Step 2 : Choose Insert

Step 3 : Choose Toolholder

Step 4 : Choose Insert Grade

Step 5 : Choose Thread Turning Speed

Step 6 : Choose Number of Threading Passes

In most cases the above mentioned 6 steps would be the steps needed to ensure a good thread. When cutting more complicated threads such as TRAPEZ, ACME, BUTTRESS or SAGE, it is advisable to check the effect of the thread "HELIX ANGLE" β on the "RESULTANT FLANK CLEARANCE" ϵ . If ϵ is smaller than 2° , an anvil change is required.

Step 7 : Find Thread Helix Angle

Step 8 : Choose Correct Anvil

EXAMPLES:

Example No. 1:

Step 1: Choose Thread Turning Method from page 58, we chose **EX - RH Insert & Toolholder**

Step 2: Choose Insert from page 13: **16 ER 16 UN**

Step 3: Choose Toolholder from page 39: **SER 0750 K16**

Step 4: Choose Insert Grade from selection on page 56
Our choice for Alloy Steel is Grade **P25C**

Step 5: Choose Thread Turning Speed from chart on page 56, we chose **330 ft/min**

Rotational Speed calculation:
$$N = \frac{330 \times 12}{\pi \times 1.25} = 1008 \text{ rpm}$$

Step 6: Choose Number of Threading passes from table on page 57, we chose **8 passes**

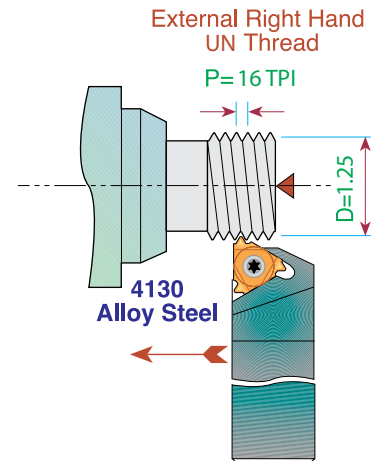

Example No. 2:

Step 1: Choose Thread Turning Method from page 58
Usually, an IN-RH Toolholder and Insert will be chosen, however, in this particular case we prefer to pull the metal chips while thread turning outward, thus we chose to work with **IN-LH Insert & Toolholder**

Step 2: Choose Insert from page 13: **16 IL 12 UN**

Step 3: Choose Toolholder from page 41: **SIL 1000 R16**
Note: since we thread cut IN-RH thread outward with an IN-LH tool, do not forget to replace the standard anvil (supplied with the holder) with a negative anvil **AE16-1.5**

Step 4: Choose Insert Grade from selection on page 56
Our choice for Brass is Grade **K20**

Step 5: Choose Thread Turning Speed from chart on page 56, we chose **450 ft/min**

Rotational Speed calculation:
$$N = \frac{450 \times 12}{\pi \times 1.5} = 1146 \text{ RPM}$$

Step 6: Choose Number of Threading passes from table on page 57, we chose **9 passes**

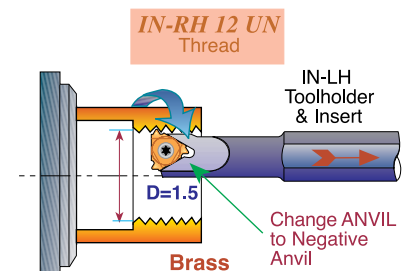

Example No. 3:

- Step 1: Choose Thread Turning Method from page 58
We chose EX-RH Insert & Toolholder.
- Step 2: Choose Insert from page 31: **16 ER 12 ABUT**
- Step 3: Choose Toolholder from page 39: **SER 1000 M16**
- Step 4: Choose Insert Grade from selection on page 56
Our choice for Stainless Steel is Grade **BMA**
- Step 5: Choose Thread Turning Speed from chart on page 57
We chose 360 ft/min.
Rotational Speed calculation:
$$N = \frac{360 \times 12}{\pi \times 1.5} = 917 \text{ RPM}$$
- Step 6: Choose Number of Threading passes from table on page 56. We chose **13 passes**
- Step 7: Find Thread Helix Angle: on page 47 for Pitch of 12 TPI and 40 Diameter
Helix Angle as shown in the chart is 1°
- Step 8: Choose correct Anvil: As can be seen from the chart on page 71, for AMERICAN BUTTRESS Thread, for 12 TPI and 40 Diameter a negative anvil **AE16-1.5** should replace the standard anvil supplied with the toolholder

EX-RH. AMERICAN BUTTRESS
12 TPI on 1.5" diameter.

Stainless Steel 304

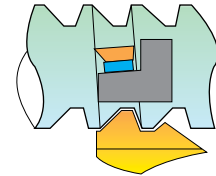

Replacing the standard anvil with an anvil with negative angle, will eliminate side rubbing

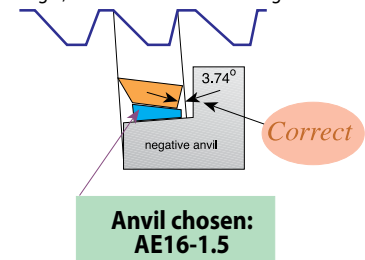

Troubleshooting

Chipping

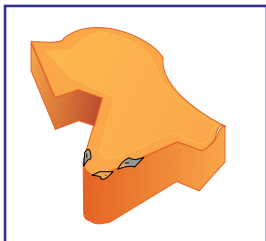

1. Use a tougher carbide grade
2. Eliminate tool overhang
3. Check if insert is correctly clamped
4. Eliminate vibration

Crater Wear



1. Reduce cutting speed
2. Apply coolant fluid
3. Use a harder carbide grade

Build-up Edge



1. Increase cutting speed
2. Use a tougher carbide grade

Thermal Cracking



1. Reduce cutting speed
2. Apply coolant fluid
3. Use a tougher carbide grade

Deformation

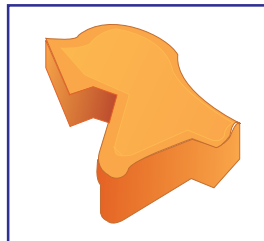

1. Use a harder carbide grade
2. Reduce cutting speed
3. Reduce depth of cut
4. Apply coolant fluid

Fracture



1. Use a tougher carbide grade
2. Reduce depth of cut
3. Index insert sooner
4. Check machine and tool stability

Threading Inserts Standards

Thread Profile	Standard	Thread Class
ISO	DIN 13	6g / 6H
UN	ANSI B1.1-1989	2A / 2B
WHITWORTH	B.S. 84: 1956	Medium Class
NPT	ANSI B1.20.1-1983	-
NPTF	ANSI B1.20.3-1976	-
BSPT	B.S. 21: 1957	-
DIN 477	DIN 477	-
ACME	ANSI B1.5-1988	3G
STUB ACME	ANSI B1.5-1988	2G
TRAPEZ	DIN 103	7e / 7H
ROUND	DIN 405	Class 7
UNJ	MIL-S-8879C	3A / 3B
MJ	ISO 5855	4h/6h 4H/5H
AMERICAN BUTTRESS	ANSI B1.9-1973	Class 2
SAGENGEWINDE	DIN 513	-
PG	DIN 40430	-
V-0.040	API Spec7	-
V-0.038R	API Spec7	-
V-0.050	API Spec7	-
V-0.055	API Spec7	-
API ROUND	API Spec Standard 5B	-
EXTREME – LINE CASING	API Spec Standard 5B	-
BUTTRESS CASING	API Spec Standard 5B	-
VAM	VAM	-

DIN: **Deutsches Institut für Normung**
 ANSI: **American National Standards Institute**
 API: **American Petroleum Institute**
 B.S.: **British Standards**
 ISO: **International Organisation for Standardisation**
 MIL-S: **Military Specification**
 P.A.C: **Pacific Asia Connection**
 P.A.C: **API Spec 7**
 HUGHES: **API Spec 7**

Grooving Tools



A combination of ground profile and sintered chip - breaker

Advantages:

- Same Toolholder for Grooving and Threading
- Minimum Investment in Tooling
 - Three cutting edges
 - Precision Ground

Contents:

Page:

Grooving Inserts	76
Grooving Inserts for Snap Ring	76
Grooving Sets	77
Technical Section	78

Grooving Inserts

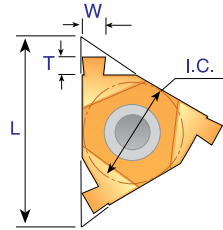

External & Internal

ER / IL

Same insert can be used for EX.RH and for IN.LH.

IR / EL

Same insert can be used for IN.RH and for EX.LH.

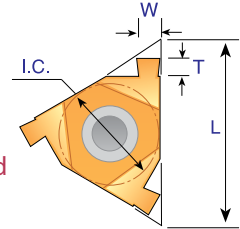

W ±.001	T	I.C.	L mm	Ordering Code		Ordering Code	
				ER/IL Inserts	Anvil	IR/EL Inserts	Anvil
.020	.055	1/4	11	11 ER/IL .020	-	11 IR/EL .020	-
.024	.055	1/4	11	11 ER/IL .024	-	11 IR/EL .024	-
.028	.055	1/4	11	11 ER/IL .028	-	11 IR/EL .028	-
.031	.055	1/4	11	11 ER/IL .031	-	11 IR/EL .031	-
.039	.051	1/4	11	11 ER/IL .039	-	11 IR/EL .039	-
.031	.055	3/8	16	16 ER/IL .031	AE 16-0	16 IR/EL .031	AI 16-0
.039	.055	3/8	16	16 ER/IL .039	AE 16-0	16 IR/EL .039	AI 16-0
.047	.063	3/8	16	16 ER/IL .047	AE 16-0	16 IR/EL .047	AI 16-0
.055	.071	3/8	16	16 ER/IL .055	AE 16-0	16 IR/EL .055	AI 16-0
.062	.075	3/8	16	16 ER/IL .062	AE 16-0	16 IR/EL .062	AI 16-0
.067	.079	3/8	16	16 ER/IL .067	AE 16-0	16 IR/EL .067	AI 16-0
.077	.079	3/8	16	16 ER/IL .077	AE 16-0	16 IR/EL .077	AI 16-0
.089	.089	3/8	16	16 ER/IL .089	AE 16-0	16 IR/EL .089	AI 16-0
.094	.089	3/8	16	16 ER/IL .094	AE 16-0	16 IR/EL .094	AI 16-0

Order example: 16 ER/IL .047 BXC

* The inserts should be used with our standard threading toolholders

* The anvil must be changed to AE 16-0 or AI 16-0 before using size 16mm (3/8") inserts

* Other available blank sizes: I.C. 5/8", 1/2", 3/16" & 5/32"

Grooving Inserts for Snap Ring

Carbide Grade: BXC

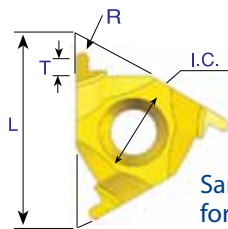

External & Internal

ER / IL

Same insert can be used for EX.RH and for IN.LH.

IR / EL

Same insert can be used for IN.RH and for EX.LH.

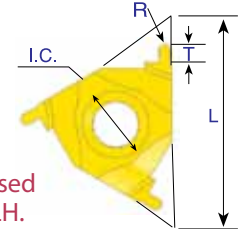

R ±.001	T	I.C.	L mm	Ordering Code		Ordering Code	
				ER/IL Inserts	Anvil	IR/EL Inserts	Anvil
.020	.055	3/8	16	16 ER/IL R0.50	AE 16 - 0	16 IR/EL R0.50	AI 16 - 0
.024	.063	3/8	16	16 ER/IL R0.60	AE 16 - 0	16 IR/EL R0.60	AI 16 - 0
.035	.079	3/8	16	16 ER/IL R0.90	AE 16 - 0	16 IR/EL R0.90	AI 16 - 0
.039	.079	3/8	16	16 ER/IL R1.00	AE 16 - 0	16 IR/EL R1.00	AI 16 - 0
.043	.087	3/8	16	16 ER/IL R1.10	AE 16 - 0	16 IR/EL R1.10	AI 16 - 0
.049	.089	3/8	16	16 ER/IL R1.20	AE 16 - 0	16 IR/EL R1.20	AI 16 - 0

Order example: 16ER/IL R1.20 BXC

* The inserts should be used with our standard threading toolholders

* The anvil must be changed to AE 16-0 or AI 16-0 before using size 16mm (3/8") inserts

* Other available blank sizes: I.C. 5/8", 1/2", 1/4", 3/16" & 5/32"

Grooving Kits



**ER / IL INSERT
KGROI - EXTERNAL**

16	ER / IL	.031	BXC	1 unit
16	ER / IL	.039	BXC	1 unit
16	ER / IL	.047	BXC	1 unit
16	ER / IL	.062	BXC	1 unit
16	ER / IL	.077	BXC	1 unit
16	ER / IL	.094	BXC	1 unit
ANVIL AE 16 - 0				1 unit

**IR / EL INSERT
KGROI - INTERNAL**

16	IR / EL	.031	BXC	1 unit
16	IR / EL	.039	BXC	1 unit
16	IR / EL	.047	BXC	1 unit
16	IR / EL	.062	BXC	1 unit
16	IR / EL	.077	BXC	1 unit
16	IR / EL	.094	BXC	1 unit
ANVIL AI 16 - 0				1 unit

Technical Section

Cutting Speeds for Grooving Tools

Carbide Grades:

BXC (P30 - P50, K25 - K40)

PVD TiN coated grade for low cutting speed. Works well with a wide range of stainless steels.

BMA (P20 - P40, K20 - K30)

PVD TiAlN coated sub-micrograin grade for stainless steels and exotic materials at medium to high cutting speeds.

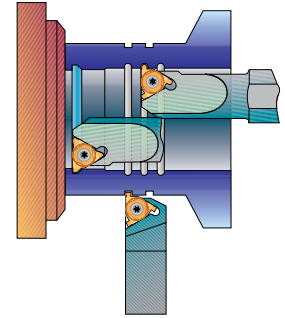

ISO Standard	Materials	Cutting Speed ft/min
P	Low & Medium Carbon Steel	65-330
	High Carbon Steel	100-260
	Alloy Steels and Treated Steels	130-300
M	Stainless Steels	100-260
	Cast Steels	100-300
K	Cast Iron	100-300
N	Non-Ferrous & Aluminum	65-660

For grooving small bores see pages 96-102

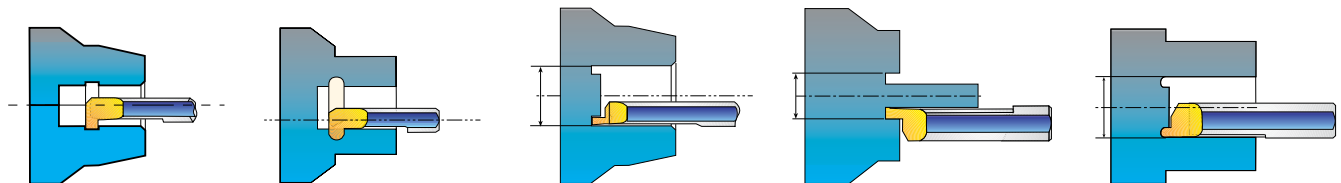

Tiny Tools

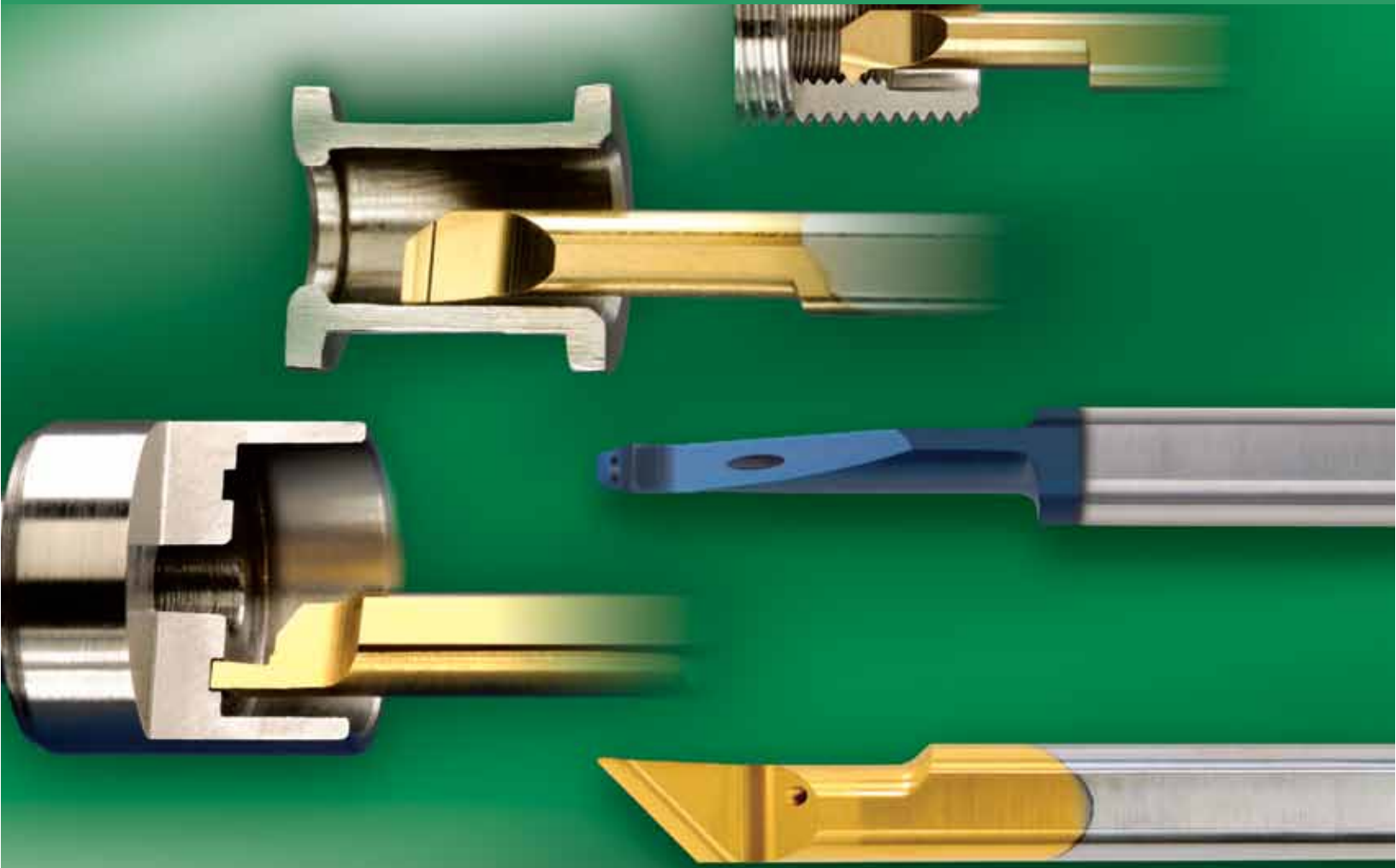

Solid Carbide tools for working in small bores

These tools are made for the high-tech, medical and small component industry. All tools include through coolant enabling the cooling fluid to reach the cutting edge efficiently, for easy chip removal and smooth cutting operations.

Contents:	Page:	Contents:	Page:
Product Identification	80	MZR Face Grooving Bars	101
MTR Boring Bars	81-82	MZL Face Grooving Bars	102
MXR Back Turning Bars	83	CMR	103
MPR Profiling and Boring Bars	84-85	CBR	104
MUR Profiling, 90° Face Cutting Bars	86	HK	105
MQR Profiling and Boring Bars	87	Tiny Tools Bar Holders	106-108
MIR Threading Bars	88-92	Tiny Toolholder for Swiss machines	109
MDR Thread Relief, Chamfering and Grooving	93	Tiny Bar Holders	110
MCR Chamfering and Boring Bars	94	Square Shank Holders	111
MWR Chamfering and Profiling Bars	95	Tiny Tools Kits	112
MGR Grooving Bars	96	Tiny Tools Technical Section	113
MKR Full Radius Grooving Bars	97	CMR	114
MFR Face Grooving Bars	98	CMR Cutting Data	115
MFL Face Grooving Bars	99	HK	115
MVR Deep Face Grooving Bars	100	HK Cutting Data	116

Product Identification

Tiny Bars Ordering Codes

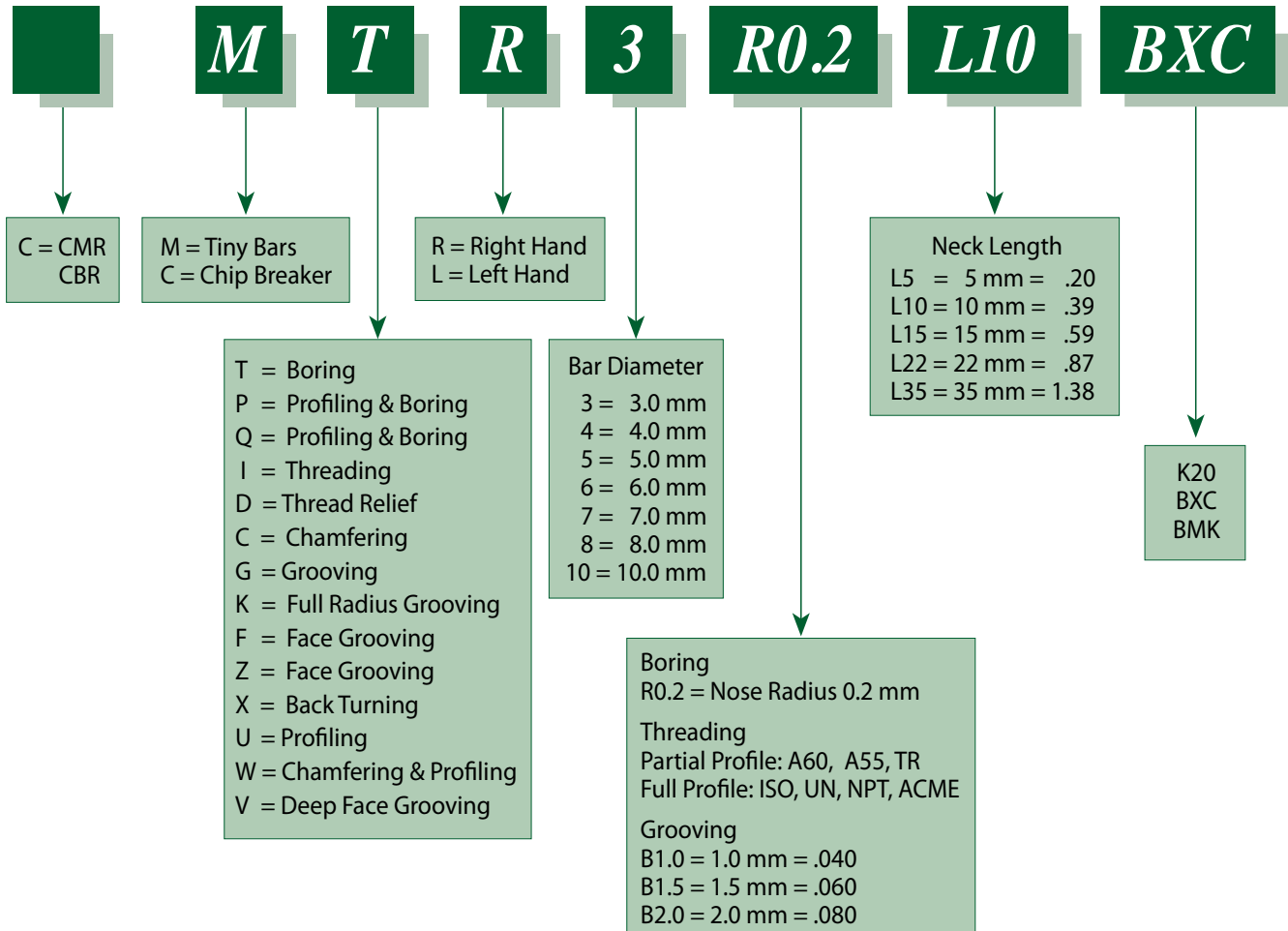

MTR Bars Boring

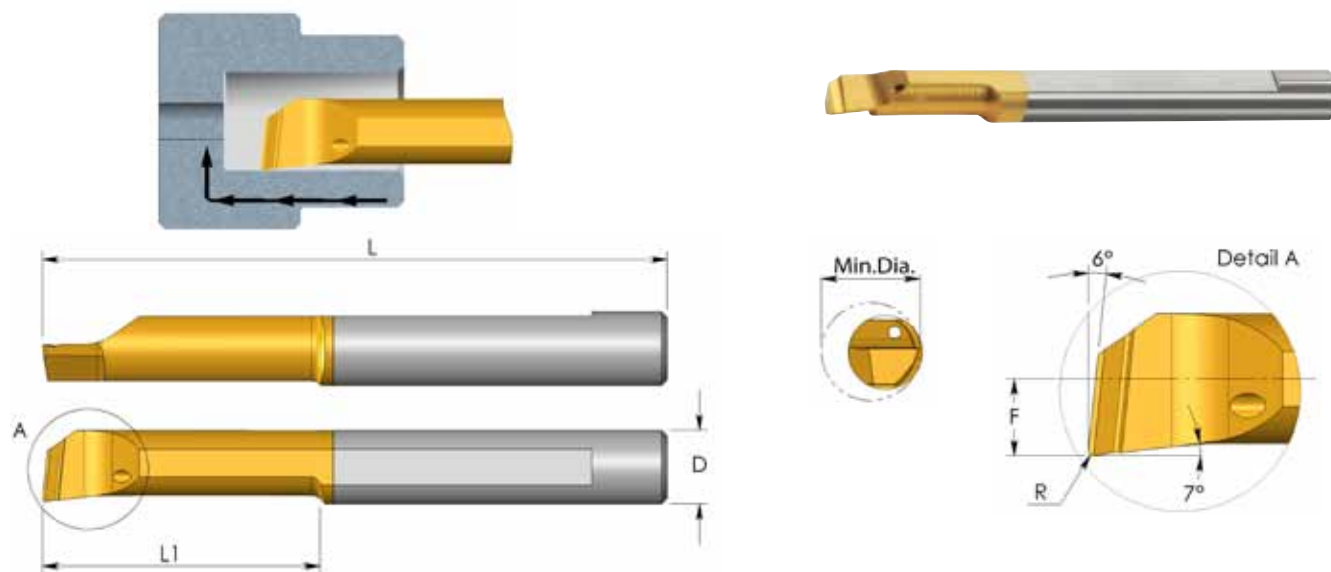

D mm	Ordering Code	L	L1	R	F	Min. Dia.	Holder**
3.0	MTR 1 R0.05 L4	1.5	.16	.002	.02	.04	SIM ... H3
	MTR 1 R0.05 L6	1.5	.24	.002	.02	.04	
3.0	MTR 1.5 R0.1 L6	1.5	.24	.004	.03	.06	SIM ... H3
3.0	MTR 2 R0.05 L10	1.5	.39	.002	.03	.08	SIM ... H3
	MTR 2 R0.15 L5	1.5	.20	.006	.03	.08	
	MTR 2 R0.15 L10	1.5	.39	.006	.03	.08	
3.0	MTR 3 R0.05 L10	1.5	.39	.002	.05	.12	SIM ... H3
	MTR 3 R0.05 L15	1.5	.59	.002	.05	.12	
	MTR 3 R0.1 L10	1.5	.39	.004	.05	.12	
	MTR 3 R0.1 L15	1.5	.59	.004	.05	.12	
	MTR 3 R0.2 L10	1.5	.39	.008	.05	.12	
	MTR 3 R0.2 L15	1.5	.59	.008	.05	.12	
4.0	MTR 4 R0.05 L15	2.0	.59	.002	.07	.16	SIM ... H4
	MTR 4 R0.1 L10	2.0	.39	.004	.07	.16	
	MTR 4 R0.1 L15	2.0	.59	.004	.07	.16	
	MTR 4 R0.1 L22	2.0	.87	.004	.07	.16	
	MTR 4 R0.2 L10	2.0	.39	.008	.07	.16	
	MTR 4 R0.2 L15	2.0	.59	.008	.07	.16	
	MTR 4 R0.2 L22	2.0	.87	.008	.07	.16	
	MTR 4 R0.2 L30	2.3	1.18	.008	.07	.16	

** For additional holders see pages 106-111

MTR Bars Boring

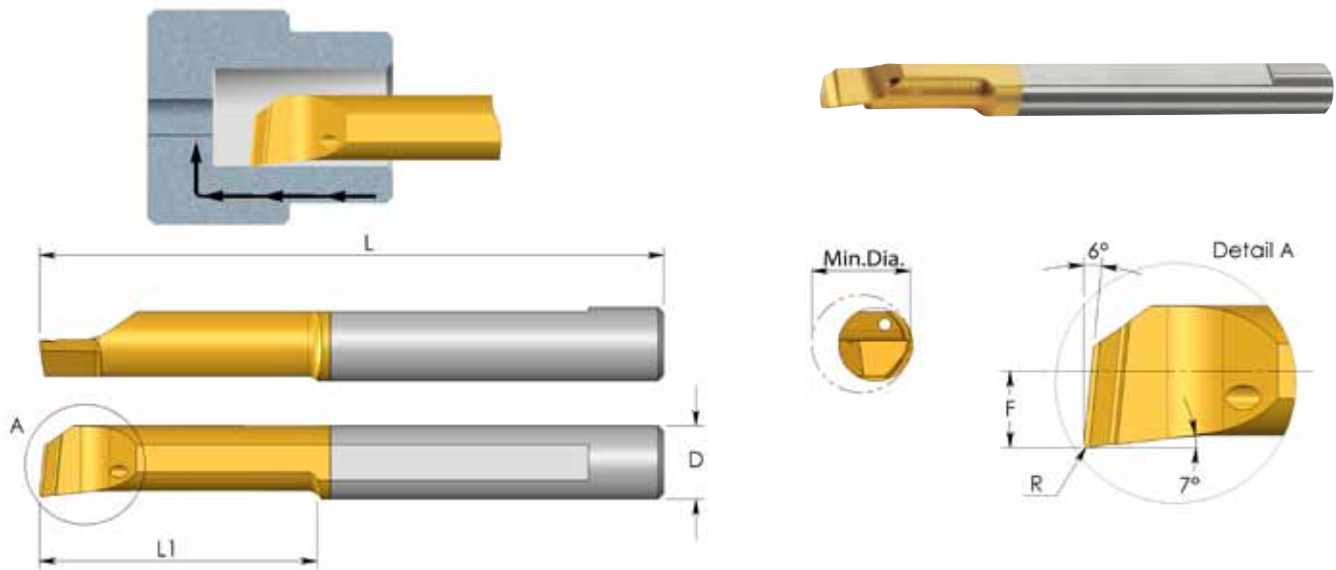

D mm	Ordering Code	L	L1	R	F	Min. Dia.	Holder**
5.0	MTR 5 R0.05 L15	2.0	.59	.002	.08	.20	SIM ... H5
	MTR 5 R0.1 L15	2.0	.59	.004	.08	.20	
	MTR 5 R0.1 L22	2.0	.87	.004	.08	.20	
	MTR 5 R0.1 L30	3.0	1.18	.004	.08	.20	
	MTR 5 R0.2 L15	2.0	.59	.008	.08	.20	
	MTR 5 R0.2 L22	2.0	.87	.008	.08	.20	
	MTR 5 R0.2 L30	3.0	1.18	.008	.08	.20	
6.0	MTR 6 R0.05 L15	2.0	.59	.002	.11	.24	SIM ... H6
	MTR 6 R0.1 L15	2.0	.59	.004	.11	.24	
	MTR 6 R0.2 L15	2.0	.59	.008	.11	.24	
	MTR 6 R0.05 L22	2.0	.87	.002	.11	.24	
	MTR 6 R0.1 L22	2.0	.87	.004	.11	.24	
	MTR 6 R0.2 L22	2.0	.87	.008	.11	.24	
	MTR 6 R0.2 L30	2.3	1.18	.008	.11	.24	
7.0	MTR 7 R0.2 L22	2.4	.87	.008	.13	.28	SIM ... H7
	MTR 7 R0.2 L30	2.4	1.18	.008	.13	.28	
8.0	MTR 8 R0.2 L15	2.5	.59	.008	.15	.32	SIM ... H8
	MTR 8 R0.2 L22	2.5	.87	.008	.15	.32	
	MTR 8 R0.2 L35	3.0	1.38	.008	.15	.32	
10.0	MTR10R0.2 L35	2.9	1.38	.008	.19	.40	SIM ... H10

Order example: MTR 4 R0.2 L15 BXC

For L.H. bars specify MTL instead of MTR

** For additional holders see pages 106-111

MXR Bars Back Turning

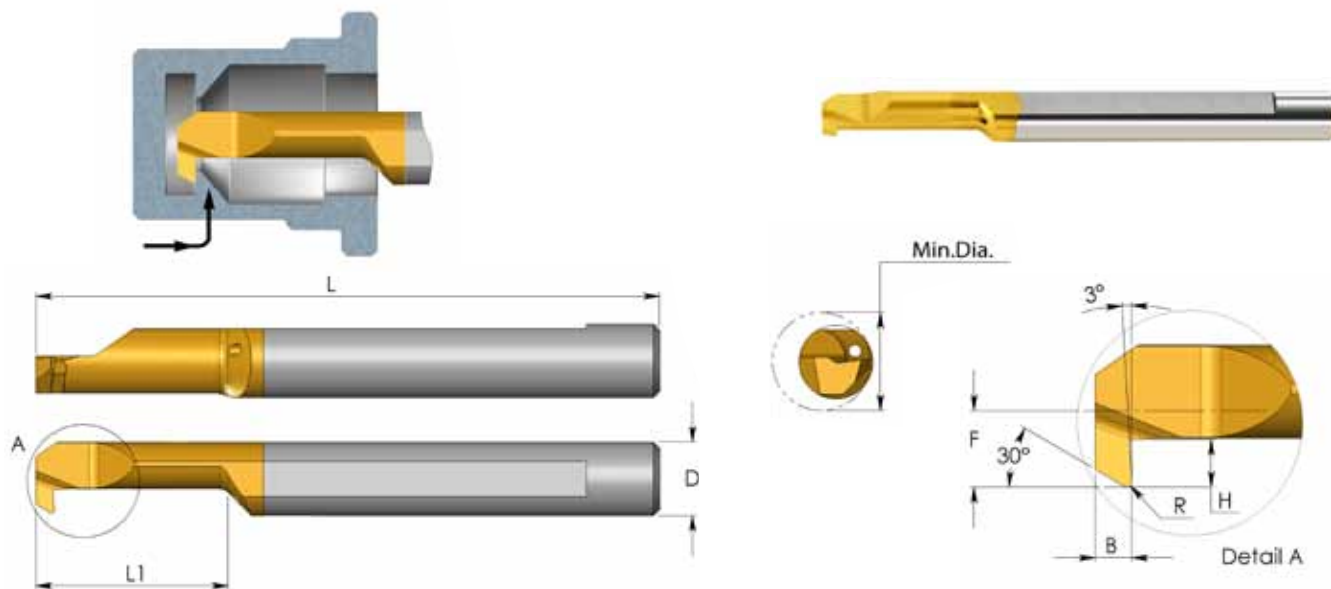

D mm	Ordering Code	L	L1	R	B	H	F	Min. Dia.	Holder*
4.0	MXR 4 R0.1 L10	2.0	.39	.004	.05	.02	.05	.12	SIM ... H4
4.0	MXR 4 R0.15 L10	2.0	.39	.006	.05	.03	.07	.16	SIM ... H4
	MXR 4 R0.15 L15	2.0	.59	.006	.05	.03	.07	.16	
5.0	MXR 5 R0.2 L15	2.0	.59	.008	.06	.04	.09	.20	SIM ... H5
	MXR 5 R0.2 L22	2.0	.87	.008	.06	.04	.09	.20	
6.0	MXR 6 R0.2 L15	2.0	.59	.008	.06	.07	.11	.24	SIM ... H6
	MXR 6 R0.2 L22	2.0	.87	.008	.06	.07	.11	.24	

Order example: MXR 4 R0.15 L15 BXC

* For additional holders see pages 106-111

MPR Bars Profiling and Boring

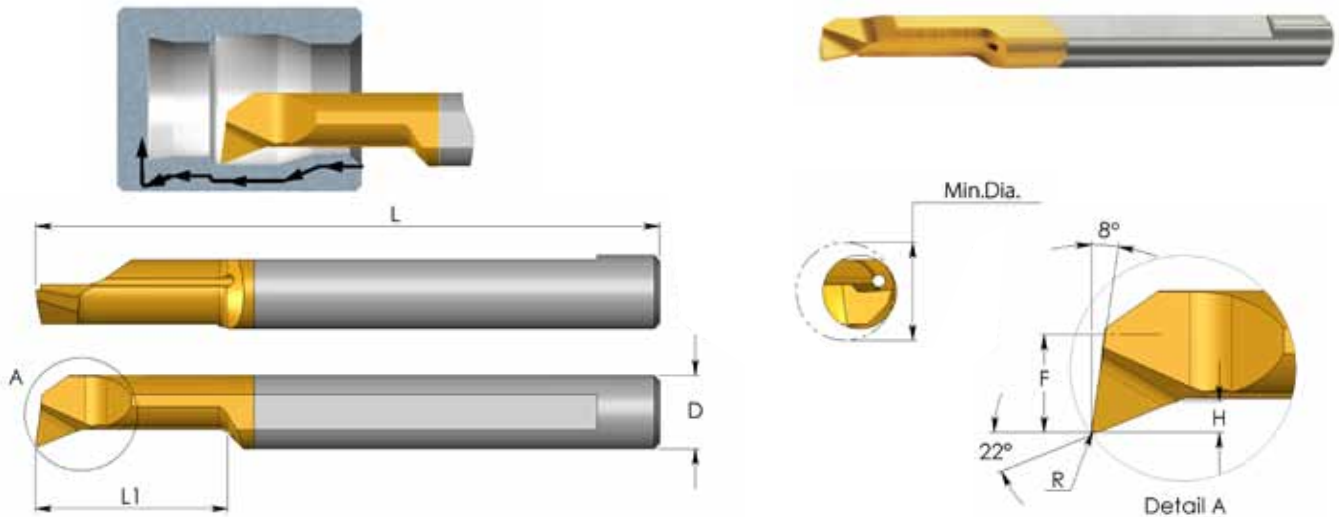

D mm	Ordering Code	L	L1	R	H	F	Min. Dia.	Holder**
3.0	MPR 1 R0.05 L4	1.5	.16	.002	.01	.02	.04	SIM ... H3
	MPR 1 R0.05 L8	1.5	.31	.002	.01	.02	.04	
3.0	MPR 1.5 R0.05 L10	1.5	.39	.002	.01	.03	.06	SIM ... H3
	MPR 1.5 R0.1 L6	1.5	.24	.004	.01	.03	.06	
	MPR 1.5 R0.1 L10	1.5	.39	.004	.01	.03	.06	
3.0	MPR 2 R0.05 L10	1.5	.39	.002	.02	.03	.08	SIM ... H3
	MPR 2 R0.1 L10	1.5	.39	.004	.02	.03	.08	
	MPR 2 R0.15 L5	1.5	.20	.006	.02	.03	.08	
	MPR 2 R0.15 L10	1.5	.39	.006	.02	.03	.08	
3.0	MPR 3 R0.05 L10	1.5	.39	.002	.03	.05	.12	SIM ... H3
	MPR 3 R0.05 L15	1.5	.59	.002	.03	.05	.12	
	MPR 3 R0.1 L15	1.5	.59	.004	.03	.05	.12	
	MPR 3 R0.1 L22	1.9	.87	.004	.03	.05	.12	
	MPR 3 R0.2 L10	1.5	.39	.008	.03	.05	.12	
	MPR 3 R0.2 L15	1.5	.59	.008	.03	.05	.12	
4.0	MPR 4 R0.1 L10	2.0	.39	.004	.03	.07	.16	SIM ... H4
	MPR 4 R0.1 L15	2.0	.59	.004	.03	.07	.16	
	MPR 4 R0.1 L22	2.0	.87	.004	.03	.07	.16	
	MPR 4 R0.2 L10	2.0	.39	.008	.03	.07	.16	
	MPR 4 R0.2 L15	2.0	.59	.008	.03	.07	.16	
	MPR 4 R0.2 L22	2.0	.87	.008	.03	.07	.16	

** For additional holders see pages 106-111

MPR Bars Profiling and Boring

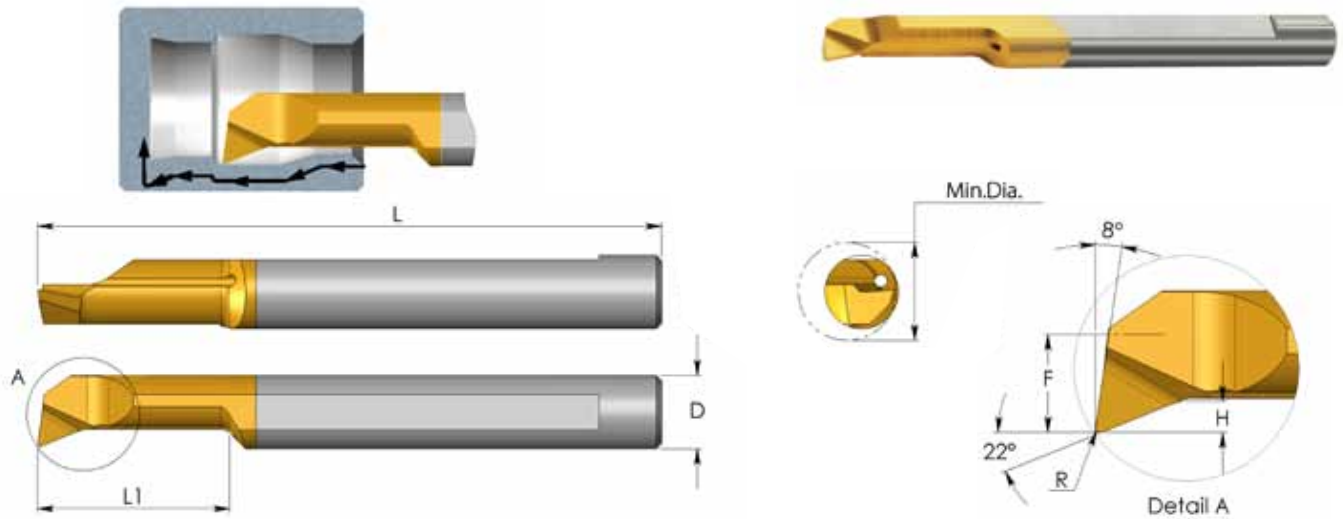

D mm	Ordering Code	L	L1	R	H	F	Min. Dia.	Holder*
5.0	MPR 5 R0.1 L22	2.0	.87	.004	.05	.08	.20	SIM ... H5
	MPR 5 R0.1 L30	3.0	1.18	.004	.05	.08	.20	
	MPR 5 R0.2 L10	2.0	.39	.008	.05	.08	.20	
	MPR 5 R0.2 L15	2.0	.59	.008	.05	.08	.20	
	MPR 5 R0.2 L22	2.0	.87	.008	.05	.08	.20	
	MPR 5 R0.2 L30	3.0	1.18	.008	.05	.08	.20	
6.0	MPR 6 R0.2 L15	2.0	.59	.008	.06	.11	.24	SIM ... H6
	MPR 6 R0.2 L22	2.0	.87	.008	.06	.11	.24	
	MPR 6 R0.2 L30	3.0	1.18	.008	.06	.11	.24	
7.0	MPR 7 R0.2 L22	2.4	.87	.008	.06	.13	.28	SIM ... H7
	MPR 7 R0.2 L30	2.4	1.18	.008	.06	.13	.28	
	MPR 7 R0.2 L35	2.4	1.38	.008	.06	.13	.28	
8.0	MPR 8 R0.2 L15	2.5	.59	.008	.06	.15	.32	SIM ... H8
	MPR 8 R0.2 L22	2.5	.87	.008	.06	.15	.32	
	MPR 8 R0.2 L35	3.0	1.38	.008	.06	.15	.32	
10.0	MPR 10 R0.2 L35	2.9	1.38	.008	.08	.19	.40	SIM ... H10

Order example: MPR 4 R0.2 L15 BXC

* For additional holders see pages 106-111

For L.H. Bars specify M^L instead of MPR

MUR Bars Profiling, 90° Face Cutting

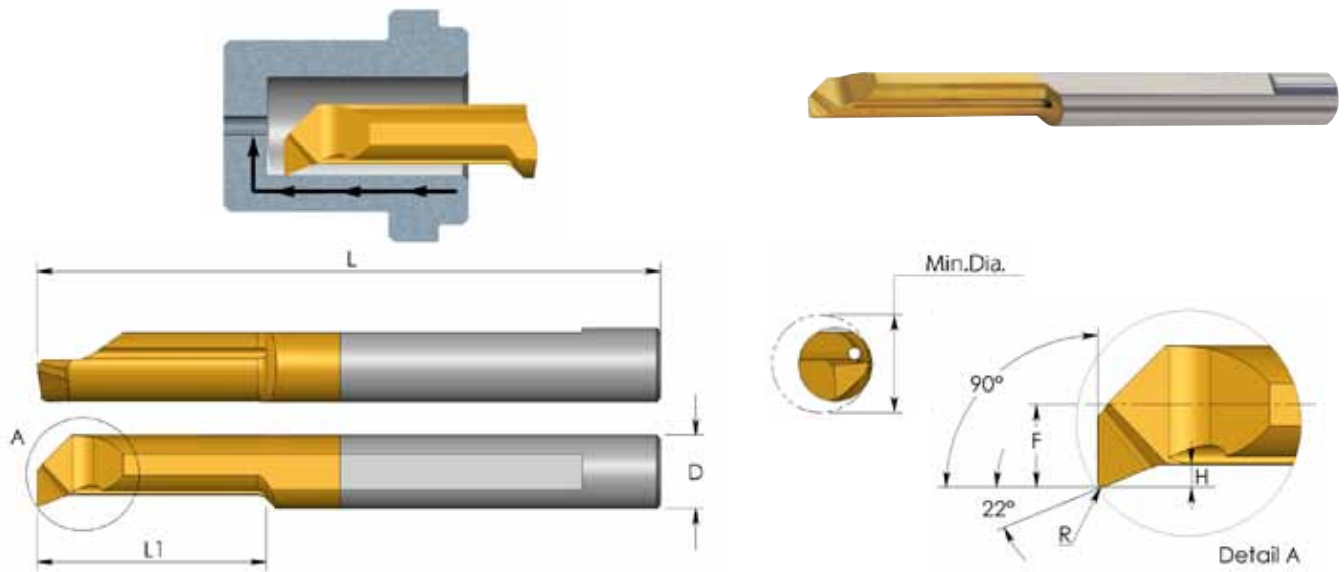

D mm	Ordering Code	L	L1	R	H	F	Min. Dia.	Holder*
3.0	MUR 3 R0.05 L10	1.5	.39	.002	.01	.05	.12	SIM ... H3
	MUR 3 R0.05 L15	1.5	.59	.002	.01	.05	.12	
4.0	MUR 4 R0.1 L10	2.0	.39	.004	.02	.07	.16	SIM ... H4
	MUR 4 R0.1 L15	2.0	.59	.004	.02	.07	.16	
5.0	MUR 5 R0.15 L15	2.0	.59	.006	.03	.08	.20	SIM ... H5
	MUR 5 R0.15 L22	2.0	.87	.006	.03	.08	.20	
6.0	MUR 6 R0.15 L15	2.0	.59	.006	.04	.11	.24	SIM ... H6
	MUR 6 R0.15 L22	2.0	.87	.006	.04	.11	.24	
8.0	MUR 8 R0.2 L22	2.5	.87	.008	.04	.15	.32	SIM ... H8

Order example: MUR 5 R0.15 L15 BXC

* For additional holders see pages 106-111

MQR Bars Profiling and Boring

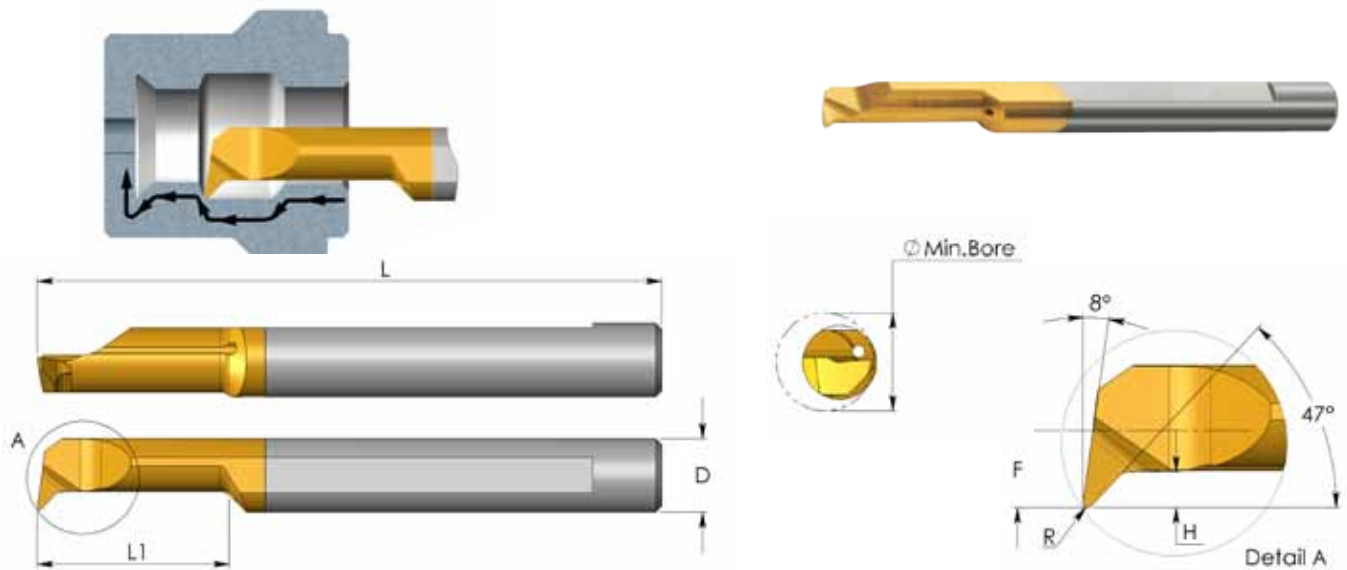

D mm	Ordering Code	L	L1	R	H	F	Min. Dia.	Holder*
4.0	MQR 4 R0.1 L22	2.0	.87	.004	.03	.07	.16	SIM ... H4
4.0	MQR 4 R0.2 L10	2.0	.39	.008	.03	.07	.16	SIM ... H4
	MQR 4 R0.2 L15	2.0	.59	.008	.03	.07	.16	
5.0	MQR 5 R0.2 L15	2.0	.59	.008	.04	.09	.20	SIM ... H5
	MQR 5 R0.2 L22	2.0	.87	.008	.04	.09	.20	
6.0	MQR 6 R0.2 L15	2.0	.59	.008	.06	.11	.24	SIM ... H6
	MQR 6 R0.2 L22	2.0	.87	.008	.06	.11	.24	
	MQR 6 R0.2 L30	2.3	1.18	.008	.06	.11	.24	
8.0	MQR 8 R0.2 L22	2.5	.87	.008	.06	.15	.32	SIM ... H8
	MQR 8 R0.2 L27	2.5	1.06	.008	.08	.15	.32	

Order example: MQR 5 R0.2 L15 BXC

For L.H. bars specify MQL instead of MQR

* For additional holders see pages 106-111

MIR Bars Threading

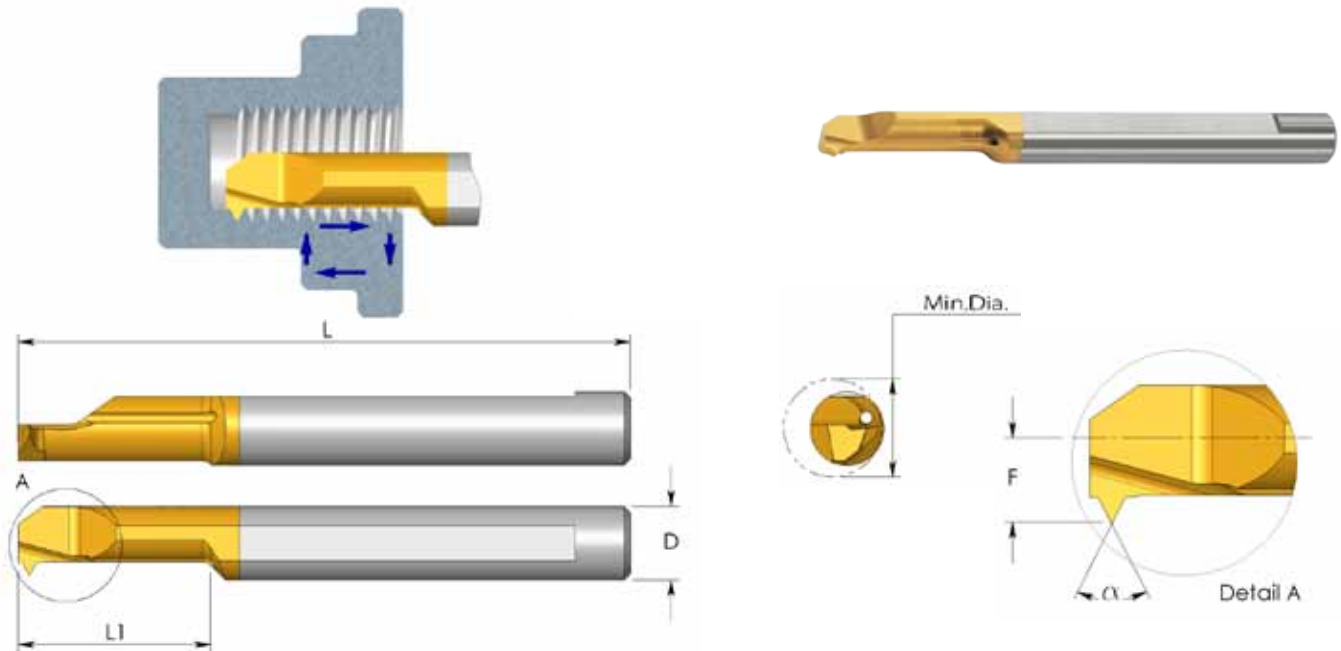

Partial Profile 55°

D mm	Ordering Code	L	L1	α	Pitch Range		F	Min. Dia.	Holder*
					mm	TPI			
3.0	MIR 3 L15 A55	1.5	.59	55	0.5 - 1.0	48 - 24	.06	.13	SIM ... H3
4.0	MIR 4 L15 A55	2.0	.59	55	0.5 - 1.0	48 - 24	.07	.16	SIM ... H4
5.0	MIR 5 L15 A55	2.0	.59	55	0.5 - 1.25	48 - 20	.09	.20	SIM ... H5
	MIR 5 L22 A55	2.0	.87	55	0.5 - 1.25	48 - 20	.09	.20	
6.0	MIR 6 L15 A55	2.0	.59	55	0.5 - 1.5	48 - 16	.10	.24	SIM ... H6
	MIR 6 L22 A55	2.0	.87	55	0.5 - 1.5	48 - 16	.10	.24	

Order example: MIR 5 L15 A55 BXC

Partial Profile 60°

D mm	Ordering Code	L	L1	α	Pitch Range		F	Min. Dia.	Holder*
					mm	TPI			
3.0	MIR 1 L5 A60	1.5	.19	60	0.25 - 0.35	100 - 72	.02	.05	SIM ... H3
	MIR 1.5 L6 A60	1.5	.25	60	0.35 - 0.45	72 - 56	.03	.06	
3.0	MIR 2 L8 A60	1.5	.31	60	0.45 - 0.7	56 - 32	.04	.08	SIM ... H3
3.0	MIR 3 L15 A60	1.5	.59	60	0.8 - 1.0	32 - 24	.06	.13	SIM ... H3
4.0	MIR 4 L15 A60	2.0	.59	60	0.8 - 1.0	32 - 24	.07	.16	SIM ... H4
5.0	MIR 5 L15 A60	2.0	.59	60	1.0 - 1.25	24 - 20	.09	.20	SIM ... H5
	MIR 5 L22 A60	2.0	.87	60	1.0 - 1.25	24 - 20	.09	.20	
6.0	MIR 6 L15 A60	2.0	.59	60	1.0 - 1.5	24 - 16	.10	.24	SIM ... H6
	MIR 6 L22 A60	2.0	.87	60	1.0 - 1.5	24 - 16	.10	.24	
8.0	MIR 8 L22 A60	2.5	.87	60	1.0 - 2.0	24 - 13	.14	.32	SIM ... H8

Order example: MIR 5 L15 A60 BXC

For L.H. bars specify MIL instead of MIR

* For additional holders see pages 106-111

MIR Bars Threading

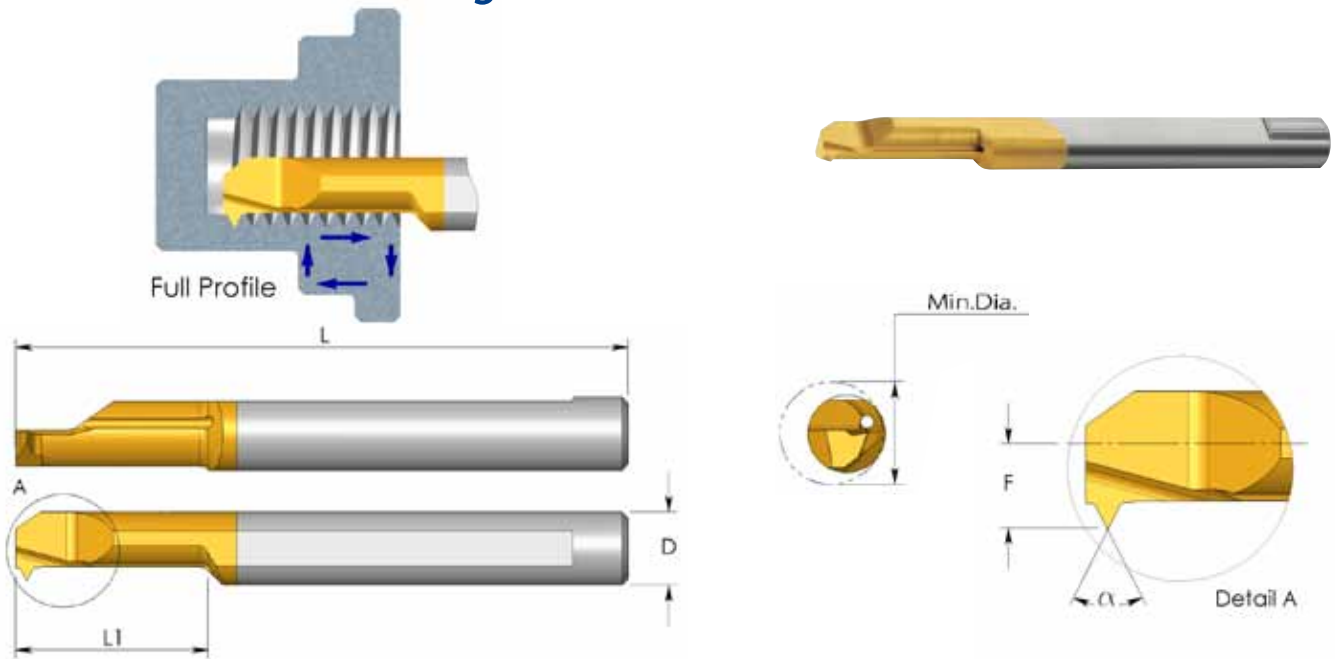

Full Profile - ISO 60°

D mm	Ordering Code	Thread	L	L1	F	Min. Dia.	Holder*
3.0	MIR 3 L10 0.5 ISO	M3 x 0.5	1.5	.39	.04	.09	SIM ... H3
	MIR 3 L15 0.5 ISO	M4 x 0.5	1.5	.59	.06	.13	
3.0	MIR 3 L15 0.7 ISO	M4 x 0.7	1.5	.59	.06	.13	SIM ... H3
	MIR 3 L15 0.75 ISO	M4.5 x 0.75	1.5	.59	.06	.13	
4.0	MIR 4 L15 0.5 ISO	M5 x 0.5	2.0	.59	.07	.16	SIM ... H4
	MIR 4 L15 0.75 ISO	M5 x 0.75	2.0	.59	.07	.16	
	MIR 4 L15 0.8 ISO	M5 x 0.8	2.0	.59	.07	.16	
5.0	MIR 5 L15 1.0 ISO	M6 x 1.0	2.0	.59	.09	.19	SIM ... H5
6.0	MIR 6 L22 1.25 ISO	M8 x 1.25	2.0	.87	.11	.24	SIM ... H6
	MIR 6 L22 1.50 ISO	M10 x 1.5	2.0	.87	.11	.24	

Order example: MIR 5 L15 1.0 ISO BXC

Full Profile - UN 60°

D mm	Ordering Code	Thread	L	L1	F	Min. Dia.	Holder*
3.0	MIR 3 L10 32 UN	6-32 UNC	1.5	.39	.04	.11	SIM ... H3
3.0	MIR 3 L15 36 UN	8-36 UNF	1.5	.59	.06	.13	SIM ... H3
	MIR 3 L15 32 UN	8-32 UNC	1.5	.59	.06	.13	
4.0	MIR 4 L15 36 UN	12-36 UNS	2.0	.59	.07	.16	SIM ... H4
	MIR 4 L15 32 UN	12-32 UNEF	2.0	.59	.07	.16	
5.0	MIR 5 L15 28 UN	1/4-28 UNF	2.0	.59	.09	.19	SIM ... H5
	MIR 5 L18 20 UN	1/4-20 UNC	2.0	.71	.09	.20	
6.0	MIR 6 L18 24 UN	5/16-24UNF	2.0	.71	.11	.26	SIM ... H6
	MIR 6 L18 18 UN	5/16-18UNC	2.0	.71	.11	.24	

Order example: MIR 4 L15 36 UN BXC

For L.H. bars specify MIL instead of MIR

* For additional holders see pages 106-111

MIR Bars Threading

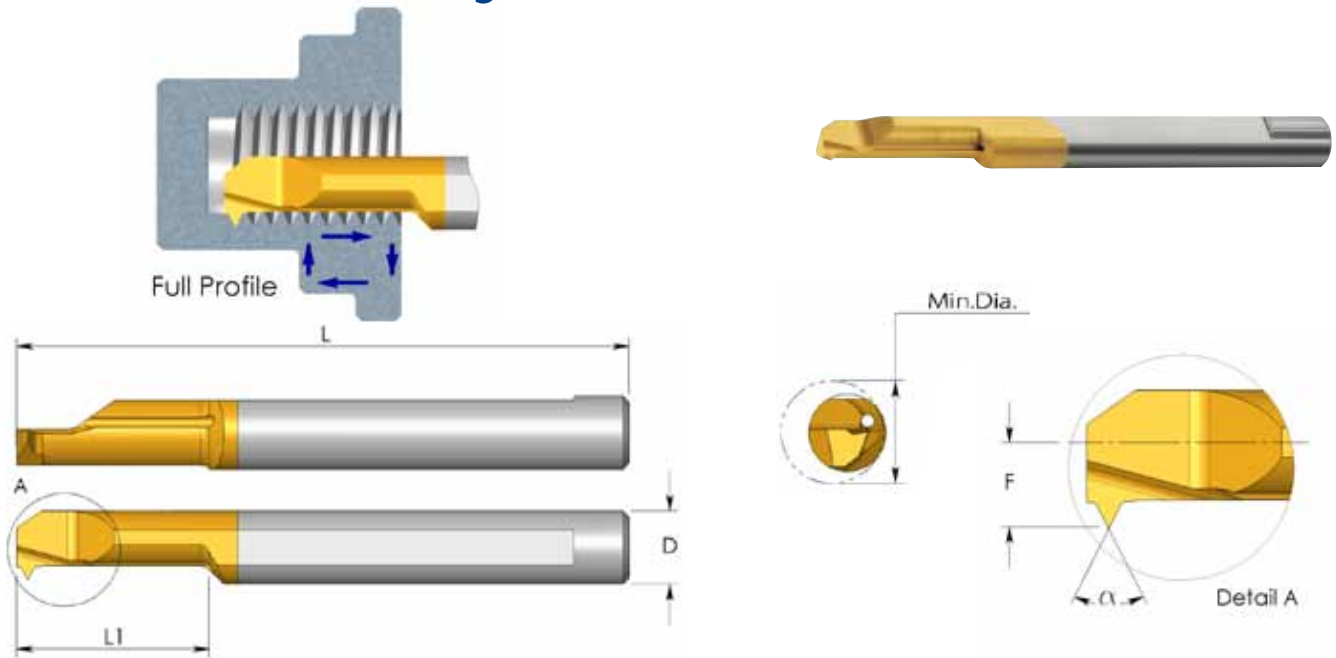

Full Profile - MJ 60°

D mm	Ordering Code	Thread Size	L	L1	α	F	Min. Dia.	Holder*
3.0	MIR 3 L15 0.7 MJ	MJ4x0.7	1.5	.59	60	.06	.13	SIM ... H3
4.0	MIR 4 L15 0.8 MJ	MJ5x0.8	2.0	.59	60	.07	.16	SIM ... H4
5.0	MIR 5 L15 1.0 MJ	MJ6x1.0	2.0	.59	60	.09	.19	SIM ... H5

Full Profile - UNJ 60°

D mm	Ordering Code	Thread Size	L	L1	α	F	Min. Dia.	Holder*
3.0	MIR 3 L15 32 UNJ	8-32 UNJC	1.5	.59	60	.06	.13	SIM ... H3
5.0	MIR 5 L15 28 UNJ	1/4-28 UNJF	2.0	.59	06	.09	.19	SIM ... H5

Full Profile - G 55° BSP

D mm	Ordering Code	Thread Size	L	L1	α	F	Min. Dia.	Holder*
6.0	MIR 6 L17 28 W	1/16-28 BSP	2.0	.67	55	.11	.26	SIM ... H6
	MIR 6 L17 19 W	1/4-19 BSP	2.0	.67	55	.11	.28	

Full Profile - Whitworth 55° BSW

D mm	Ordering Code	Thread Size	L	L1	α	F	Min. Dia.	Holder*
5.0	MIR 5 L17 20 W	1/4-20 BSW	2.0	.67	55	.08	.19	SIM ... H5

* For additional holders see pages 106-111

MIR Bars Threading

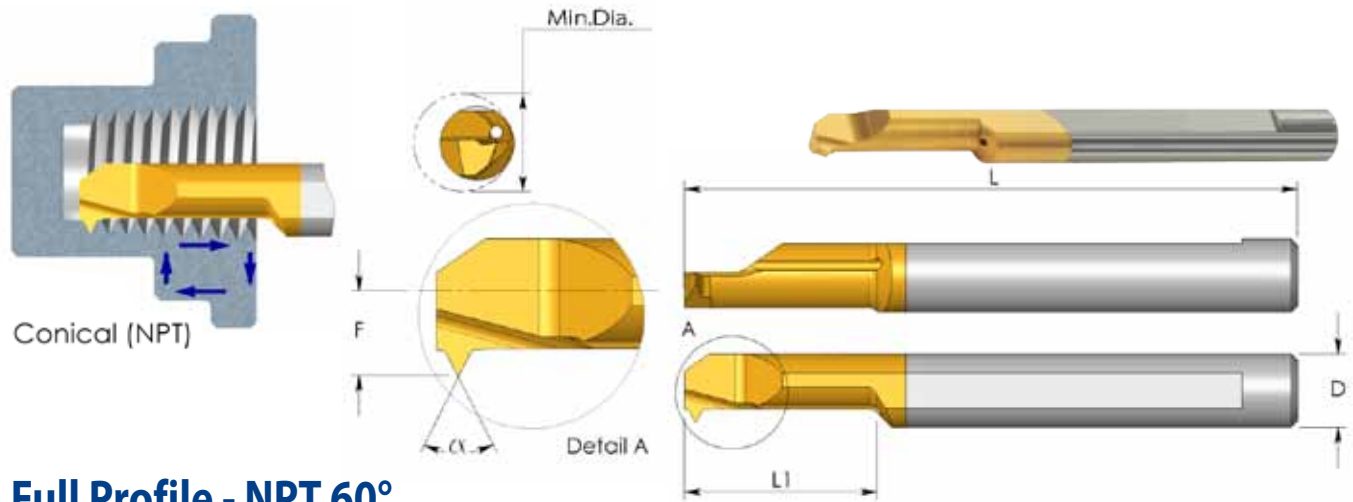

Full Profile - NPT 60°

D mm	Ordering Code	Pitch TPI	Thread Size	L	L1	α	F	Min. Dia.	Holder*
6.0	MIR 6 L15 27 NPT	27	1/16 x 27 NPT 1/8 x 27 NPT	2.0	.59	60	.10	.23	SIM ... H6

Order example: MIR 6 L15 27 NPT BXC

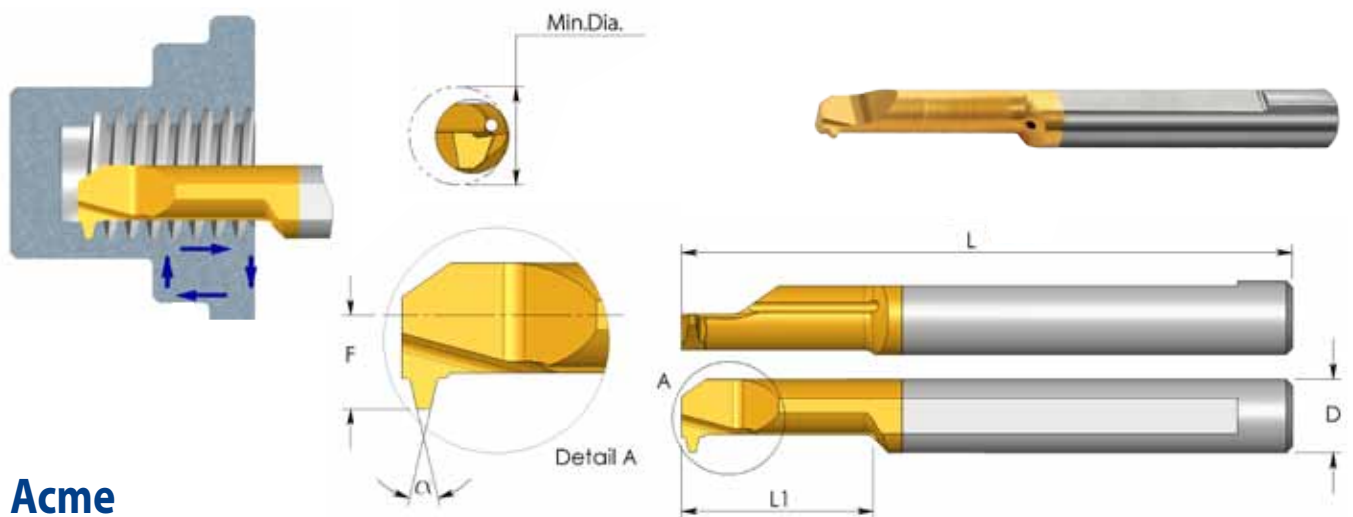

Acme

D mm	Ordering Code	Pitch TPI	Thread Size	L	L1	F	α	Min. Dia.	Holder*
4.0	MIR 4 L15 16 ACME	16	1/4 x 16	2.0	.59	.07	29	.18	SIM ... H4
6.0	MIR 6 L20 14 ACME	14	5/16 x 14	2.0	.79	.11	29	.24	SIM ... H6
7.0	MIR 7 L22 12 ACME	12	3/8 x 12 7/16 x 12	2.4	.87	.13	29	.28	SIM ... H7
8.0	MIR 8 L30 10 ACME	10	1/2 x 10	3.0	1.18	.15	29	.39	SIM ... H8
10.0	MIR 10 L35 8 ACME	8	5/8 x 8	3.0	1.38	.19	29	.49	SIM ... H10
10.0	MIR 10 L45 6 ACME	6	3/4 x 6 7/8 x 6	4.1	1.77	.19	29	.57	SIM ... H10
10.0	MIR 10 L52 5 ACME	5	1 x 5	4.1	2.05	.19	29	.79	SIM ... H10

Order example: MIR 6 L 20 14 ACME BXC

* For additional holders see pages 106-111

MIR Bars Threading

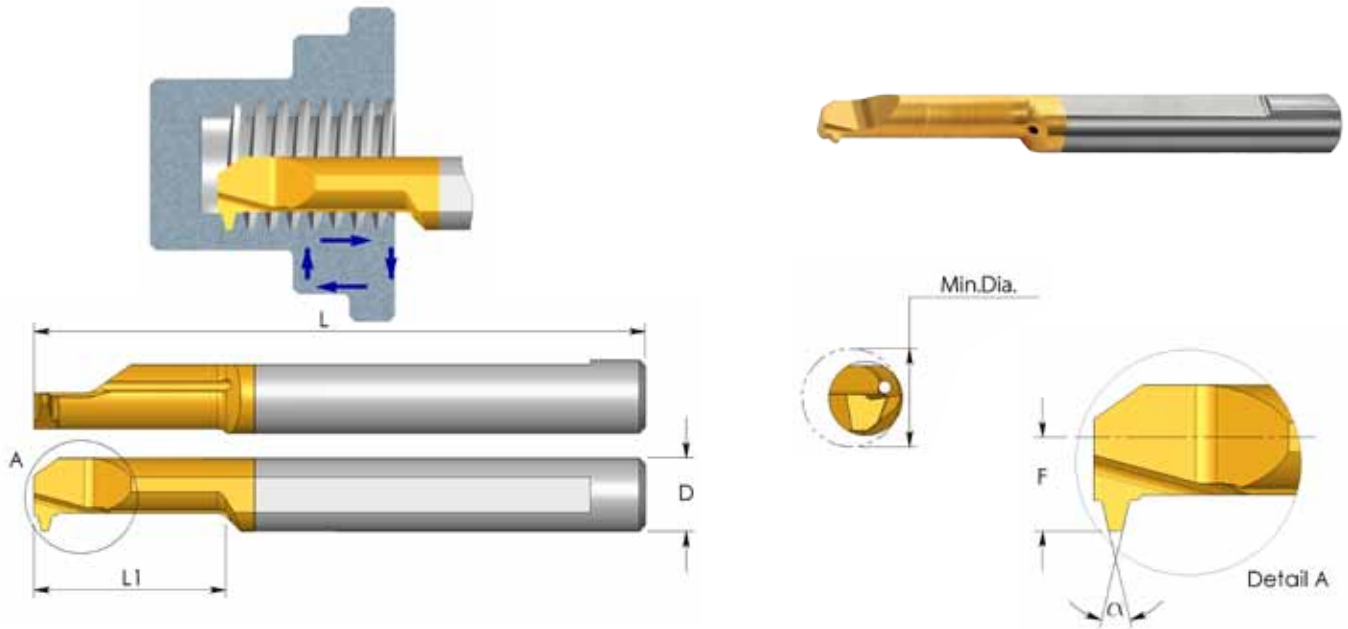

Partial Profile Trapez - DIN 103

D mm	Ordering Code	Pitch mm	Thread Size	L	L1	F	α	Min. Dia.	Holder*
6.0	MIR 6 L22 1.5 TR	1.5	TR 8 x 1.5 TR 9 x 1.5 TR10 x 1.5	2.0	.87	.11	30	.25	SIM ... H6
7.0	MIR 7 L25 2 TR	2	TR 9 x 2 TR10 x 2 TR11 x 2 TR12 x 2	2.4	.98	.13	30	.27	SIM ... H7
10.0	MIR 10 L35 2 TR	2	TR14 x 2 TR16 x 2 TR18 x 2 TR20 x 2	2.9	1.38	.19	30	.43	SIM ... H10
7.0	MIR 7 L35 3 TR	3	TR11 x 3 TR12 x 3	2.4	1.38	.13	30	.30	SIM ... H7
10.0	MIR 10 L35 3 TR	3	TR14 x 3 TR22 x 3 TR24 x 3 TR26 x 3 TR28 x 3	2.9	1.38	.19	30	.41	SIM ... H10
10.0	MIR 10 L45 4 TR	4	TR16 x 4 TR18 x 4 TR20 x 4	4.1	1.77	.19	30	.45	SIM ... H10
10.0	MIR 10 L55 5 TR	5	TR22 x 5 TR24 x 5 TR28 x 5	4.1	2.17	.19	30	.43	SIM ... H10

Order example: MIR 10 L35 3 TR BXC

* For additional holders see pages 106-111

MDR Bars *Thread Relief, Chamfering and Grooving*

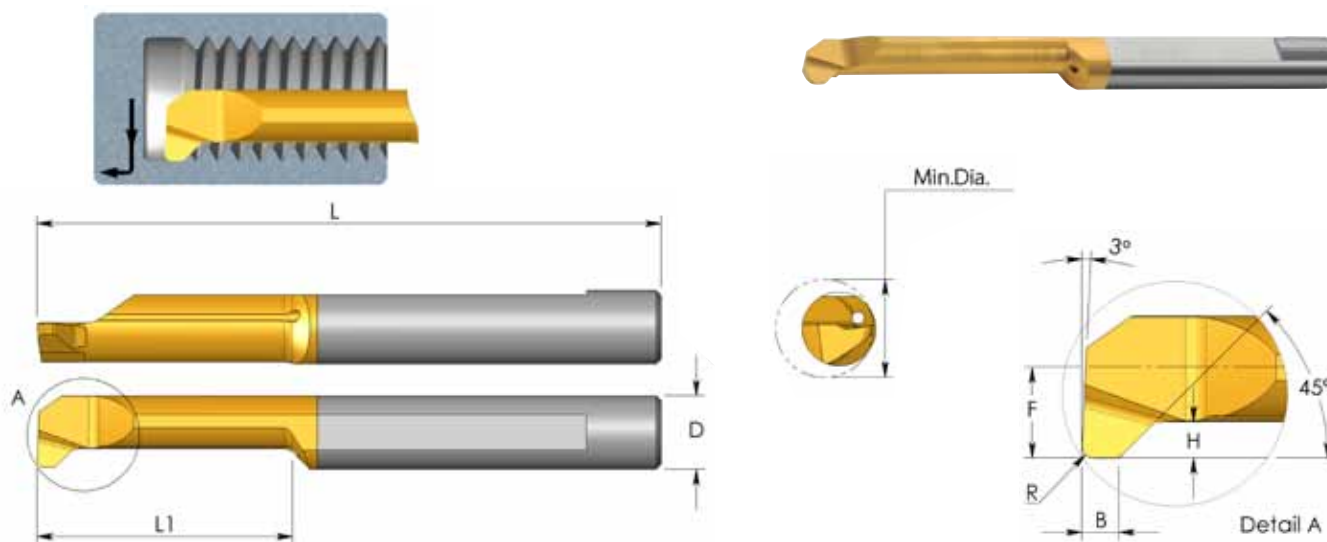

D mm	Ordering Code	L	L1	B	R	H	F	Min. Dia.	Holder*
4.0	MDR 4 R0.5 L18	2.0	.71	.06	.02	.03	.07	.16	SIM ... H4
5.0	MDR 5 R0.5 L24	2.0	.94	.06	.02	.05	.09	.20	SIM ... H5
6.0	MDR 6 R0.5 L27	2.3	1.06	.06	.02	.06	.11	.24	SIM ... H6

Order example: MDR 5 R0.5 L24 BXC

For L.H. bars specify MDL instead of MDR

* For additional holders see pages 106-111

MCR Bars Chamfering and Boring

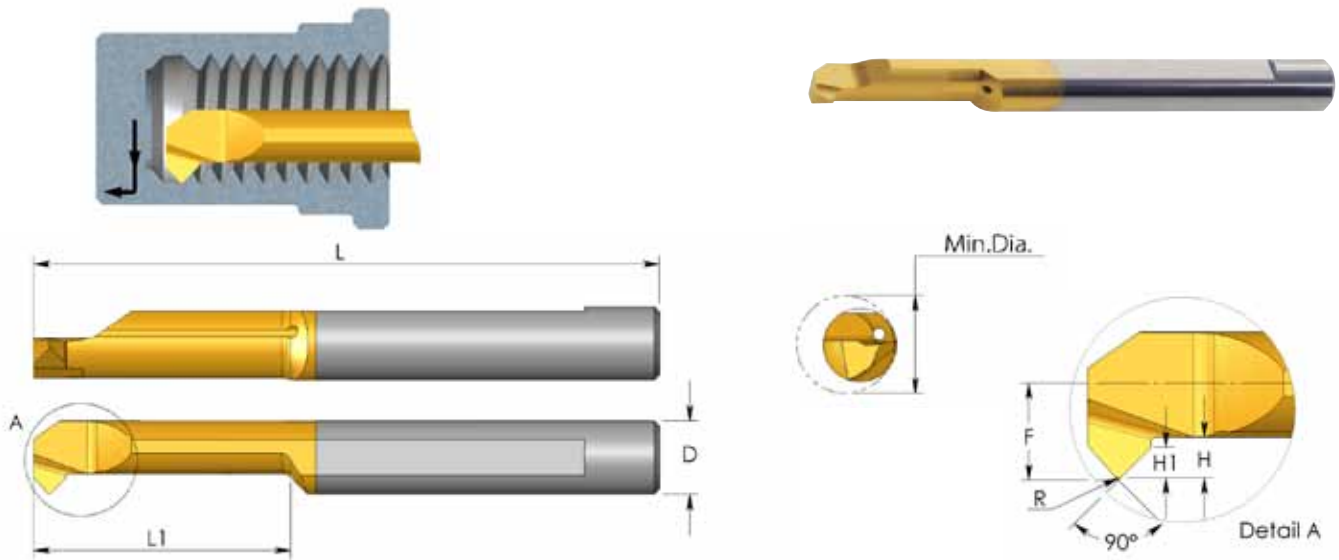

D mm	Ordering Code	L	L1	R	H	H1	F	Min. Dia.	Holder*
3.0	MCR 3 R0.2 L10	1.5	.39	.008	.03	.01	.05	.12	SIM ... H3
4.0	MCR 4 R0.2 L15	2.0	.59	.008	.03	.02	.07	.16	SIM ... H4
5.0	MCR 5 R0.2 L15	2.0	.59	.008	.05	.03	.08	.20	SIM ... H5
6.0	MCR 6 R0.2 L15	2.0	.59	.008	.06	.03	.11	.24	SIM ... H6
7.0	MCR 7 R0.2 L20	2.4	.79	.008	.06	.03	.13	.28	SIM ... H7

Order example: MCR 4 R0.2 L15 BXC

For L.H. bars specify MCL instead of MCR

* For additional holders see pages 106-111

MWR Bars Chamfering and Profiling

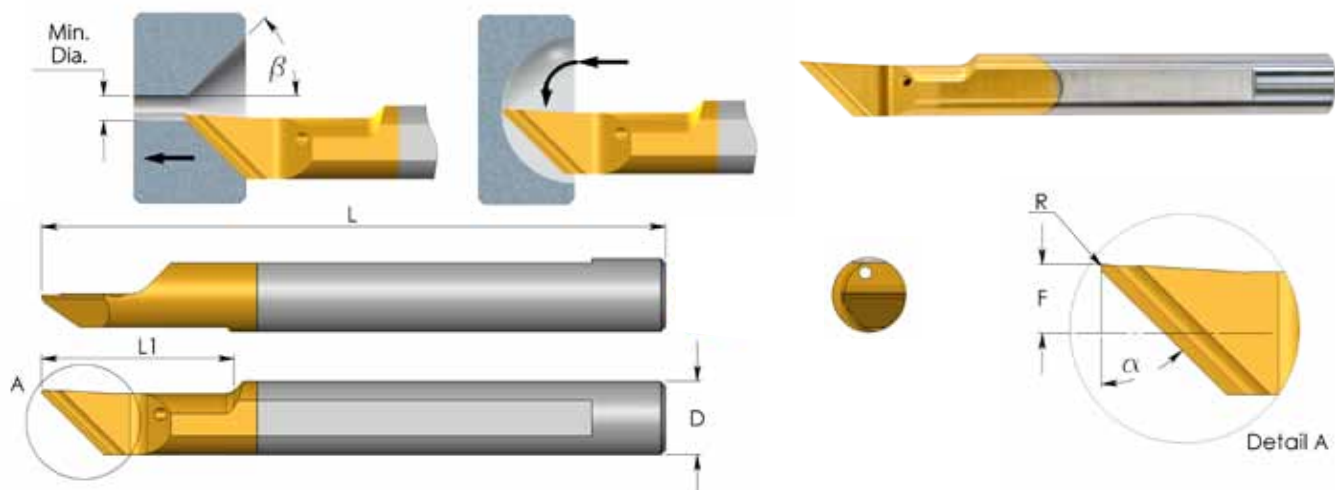

D mm	Ordering Code	L	L1	R	α	β	F	Min. Dia.	Holder**
6.0	MWR 6 R0.2 A90	2.0	.59	.008	45°	45°	.09	.04	SIM ... H6
	MWR 6 R0.2 A60	2.0	.59	.008	60°	30°	.09	.04	
6.0	* MWR 6 R0.4 A60	2.0	.87	.016	45°	45°	.09	.24	
	* MWR 6 R0.4 A90	2.0	.87	.016	60°	30°	.09	.24	

Order example: MWR 6 R0.2 A90 BXC

For L.H. bars specify MWL instead of MWR

* Can be used also for boring

** For additional holders see pages 106-111

MGR Bars Grooving

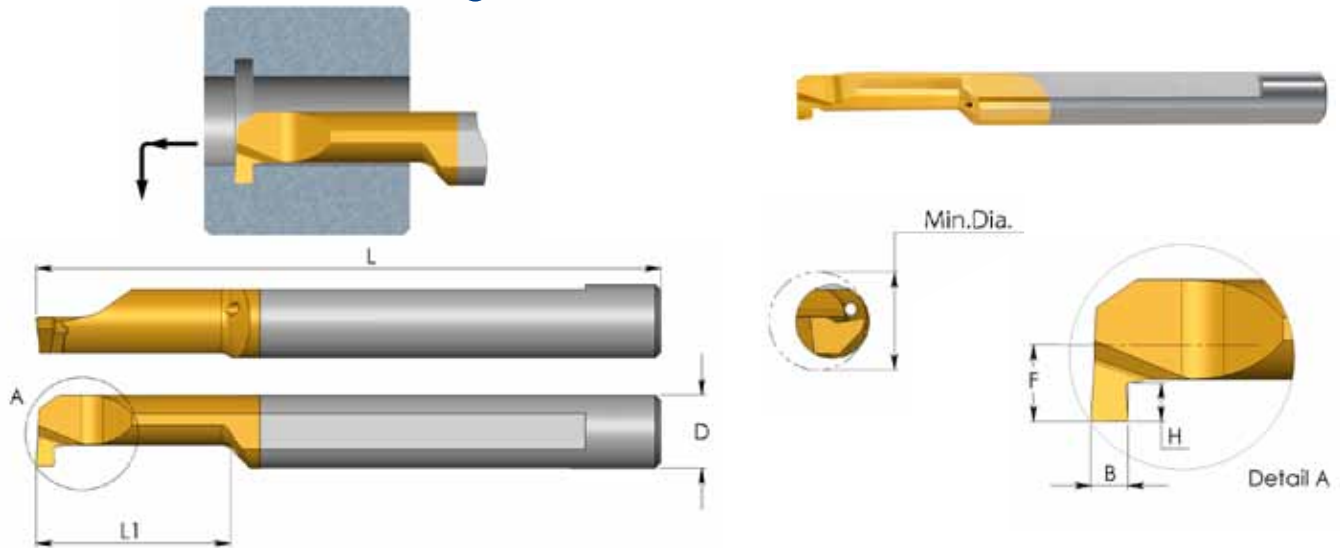

D mm	Ordering Code	L	L1	B	H	F	Min. Dia.	Holder*
3.0	MGR 3 B0.7 L10	1.5	.39	.03	.02	.05	.12	SIM ... H3
	MGR 4 B0.5 L10	2.0	.39	.02	.02	.07	.16	
4.0	MGR 4 B0.7 L10	2.0	.39	.03	.02	.07	.16	SIM ... H4
	MGR 4 B1.0 L10	2.0	.39	.04	.04	.07	.16	
	MGR 4 B1.0 L15	2.0	.59	.04	.04	.07	.16	
	MGR 4 B1.0 L22	2.0	.87	.04	.04	.07	.16	
	MGR 4 B1.5 L10	2.0	.39	.06	.04	.07	.16	
5.0	MGR 5 B1.0 L15	2.0	.59	.04	.05	.09	.20	SIM ... H5
	MGR 5 B1.0 L22	2.0	.87	.04	.05	.09	.20	
	MGR 5 B1.5 L15	2.0	.59	.06	.05	.09	.20	
	MGR 5 B1.5 L22	2.0	.87	.06	.05	.09	.20	
	MGR 5 B2.0 L15	2.0	.59	.08	.05	.09	.20	
6.0	MGR 5 B2.0 L22	2.0	.87	.08	.05	.09	.20	SIM ... H6
	MGR 6 B1.0 L15	2.0	.59	.04	.06	.11	.24	
	MGR 6 B1.0 L17	2.0	.67	.04	.07	.11	.24	
	MGR 6 B1.0 L22	2.0	.87	.04	.06	.11	.24	
	MGR 6 B1.5 L15	2.0	.59	.06	.06	.11	.24	
	MGR 6 B1.5 L17	2.0	.67	.06	.07	.11	.24	
	MGR 6 B1.5 L22	2.0	.87	.06	.06	.11	.24	
	MGR 6 B1.5 L23	2.0	.91	.06	.07	.11	.24	
	MGR 6 B2.0 L15	2.0	.59	.08	.06	.11	.24	
	MGR 6 B2.0 L17	2.0	.67	.08	.07	.11	.24	
7.0	MGR 6 B2.0 L22	2.0	.87	.08	.06	.11	.24	SIM ... H7
	MGR 6 B2.0 L23	2.0	.91	.08	.07	.11	.24	
	MGR 7 B1.0 L15	2.4	.59	.04	.10	.13	.28	
	MGR 7 B1.0 L22	2.4	.87	.04	.10	.13	.28	
	MGR 7 B1.0 L30	2.4	1.18	.04	.10	.13	.28	
	MGR 7 B1.5 L15	2.4	.59	.06	.10	.13	.28	
	MGR 7 B1.5 L22	2.4	.87	.06	.10	.13	.28	
	MGR 7 B1.5 L30	2.4	1.18	.06	.10	.13	.28	
8.0	MGR 7 B2.0 L15	2.4	.59	.08	.10	.13	.28	SIM ... H8
	MGR 7 B2.0 L22	2.4	.87	.08	.10	.13	.28	
	MGR 7 B2.0 L30	2.4	1.18	.08	.10	.13	.28	
	MGR 8 B1.0 L22	2.5	.87	.04	.07	.15	.32	
8.0	MGR 8 B1.5 L22	2.5	.87	.06	.07	.15	.32	SIM ... H8
	MGR 8 B2.0 L22	2.5	.87	.08	.10	.15	.32	

Order example: MGR 5 B1.5 L15 BXC
 For L.H. bars specify MGL instead of MGR
 * For additional holders see pages 106-111

MKR Bars Full Radius Grooving

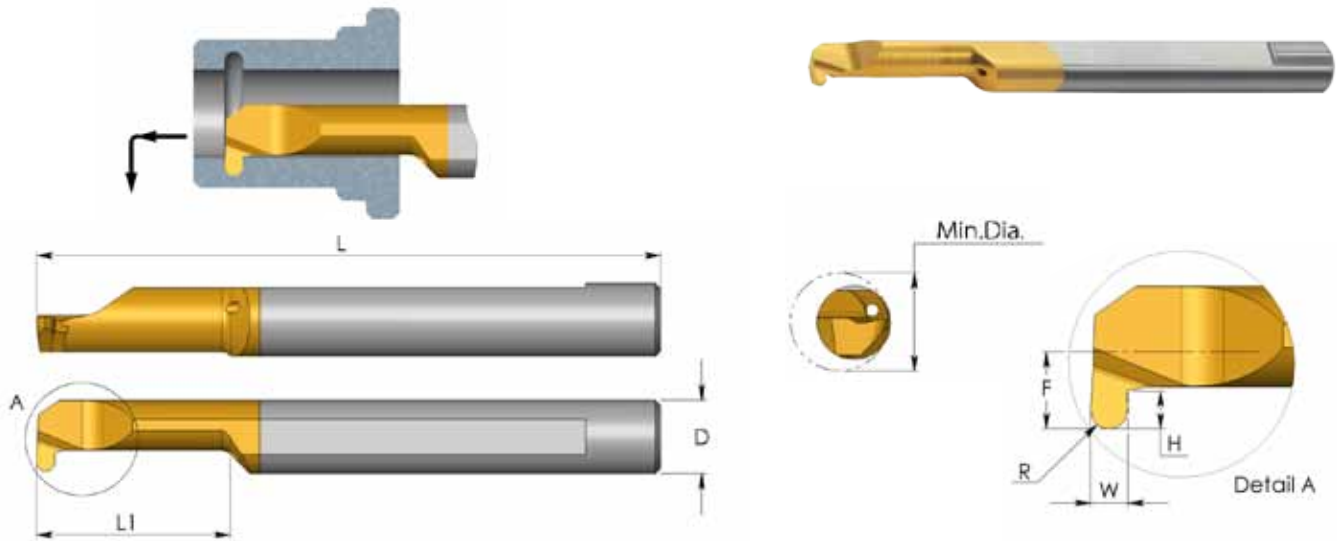

D mm	Ordering Code	L	L1	R	W	H	F	Min. Dia.	Holder*
4.0	MKR 4 R0.5 L10	2.0	.39	.020	.04	.04	.07	.16	SIM ... H4
	MKR 4 R0.5 L15	2.0	.59	.020	.04	.04	.07	.16	
	MKR 4 R0.75 L10	2.0	.39	.030	.06	.04	.07	.16	
5.0	MKR 5 R0.5 L15	2.0	.59	.020	.04	.05	.09	.20	SIM ... H5
	MKR 5 R0.75 L15	2.0	.59	.030	.06	.05	.09	.20	
	MKR 5 R1.0 L15	2.0	.59	.039	.08	.05	.09	.20	
	MKR 5 R1.0 L22	2.0	.87	.039	.08	.05	.09	.20	
6.0	MKR 6 R0.5 L15	2.0	.59	.020	.04	.06	.11	.24	SIM ... H6
	MKR 6 R0.75 L15	2.0	.59	.030	.06	.06	.11	.24	
	MKR 6 R1.0 L15	2.0	.59	.039	.08	.06	.11	.24	
	MKR 6 R1.0 L23	2.0	.91	.039	.08	.07	.11	.24	
7.0	MKR 7 R0.5 L22	2.4	.87	.020	.04	.10	.13	.28	SIM ... H7
	MKR 7 R0.75 L22	2.4	.87	.030	.06	.10	.13	.28	
	MKR 7 R1.0 L22	2.4	.87	.039	.08	.10	.13	.28	

Order example: MKR 5 R1.0 L15 BXC

For L.H. bars specify MKL instead of MKR

* For additional holders see pages 106-111

MFR Bars Face Grooving

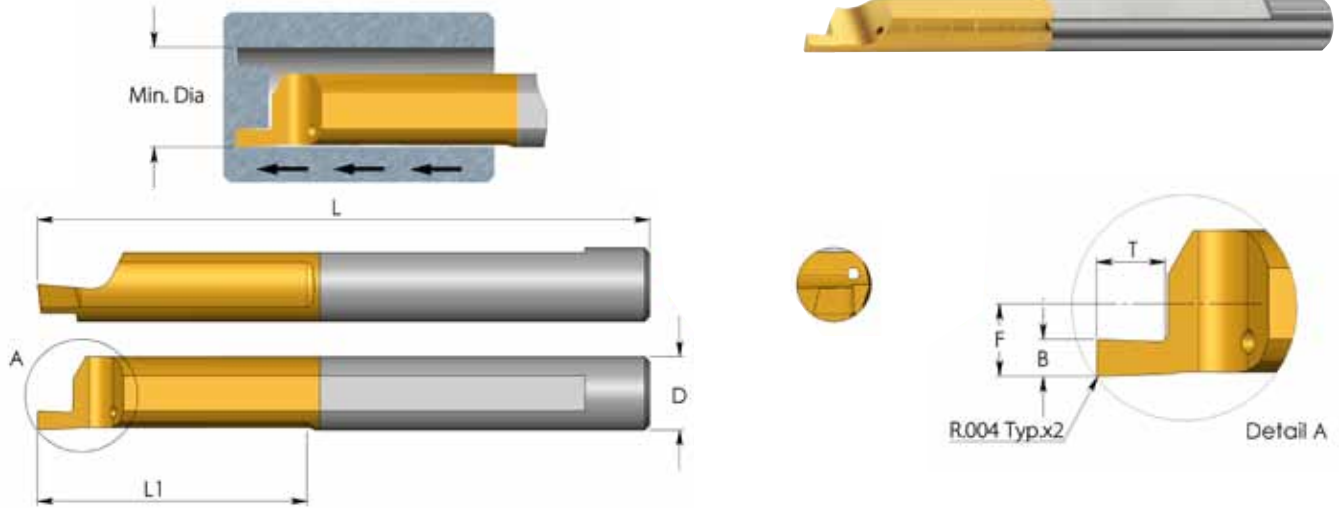

D mm	Ordering Code	L	L1	B	T	F	Min. Dia.	Holder*
4.0	MFR 4 B0.75 L15	2.0	.59	.03	.05	.08	.20	SIM ... H4
	MFR 4 B1.0 L15	2.0	.59	.04	.06	.08	.20	
	MFR 4 B1.5 L15	2.0	.59	.06	.11	.08	.20	
	MFR 4 B1.5 L17	2.0	.67	.06	.14	.08	.20	
	MFR 4 B2.0 L17	2.0	.67	.08	.20	.08	.20	
5.0	MFR 5 B0.75 L22	2.0	.87	.03	.05	.10	.24	SIM ... H5
	MFR 5 B1.0 L22	2.0	.87	.04	.06	.10	.24	
	MFR 5 B1.0 L23	2.0	.91	.04	.10	.10	.24	
	MFR 5 B1.5 L22	2.0	.87	.06	.10	.10	.24	
	MFR 5 B1.5 L23	2.0	.91	.06	.14	.10	.24	
	MFR 5 B2.0 L22	2.0	.87	.08	.15	.10	.24	
	MFR 5 B2.0 L23	2.0	.91	.08	.20	.10	.24	
6.0	MFR 6 B1.0 L22	2.0	.87	.04	.06	.12	.31	SIM ... H6
	MFR 6 B1.5 L22	2.0	.87	.06	.10	.12	.31	
	MFR 6 B2.0 L22	2.0	.87	.08	.12	.12	.31	
	MFR 6 B2.5 L22	2.0	.87	.10	.19	.12	.31	
	MFR 6 B3.0 L30	2.3	1.18	.12	.24	.12	.31	
8.0	MFR 8 B2.5 L22	2.5	.87	.10	.14	.16	.39	SIM ... H8

Order example: MFR 5 B1.0 L22 BXC

* For additional holders see pages 106-111

MFL Bars Face Grooving

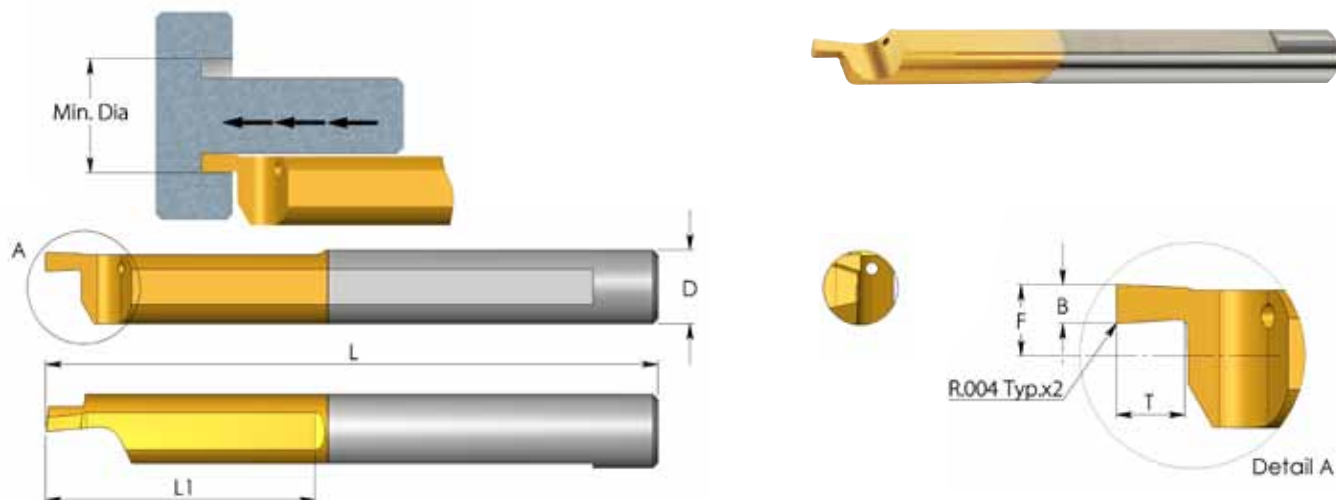

D mm	Ordering Code	L	L1	B	T	F	Min. Dia.	Holder*
4.0	MFL 4 B0.75 L15	2.0	.59	.03	.05	.07	.20	SIM ... H4
	MFL 4 B1.0 L15	2.0	.59	.04	.06	.07	.20	
	MFL 4 B1.5 L15	2.0	.59	.06	.11	.07	.20	
	MFL 4 B1.5 L17	2.0	.67	.06	.12	.07	.20	
	MFL 4 B2.0 L17	2.0	.67	.08	.20	.07	.20	
5.0	MFL 5 B0.75 L22	2.0	.87	.03	.05	.09	.24	SIM ... H5
	MFL 5 B1.0 L22	2.0	.87	.04	.06	.09	.24	
	MFL 5 B1.0 L23	2.0	.91	.04	.10	.09	.24	
	MFL 5 B1.5 L22	2.0	.87	.06	.10	.09	.24	
	MFL 5 B1.5 L23	2.0	.91	.06	.14	.09	.24	
	MFL 5 B2.0 L22	2.0	.87	.08	.15	.09	.24	
	MFL 5 B2.0 L23	2.0	.91	.08	.20	.09	.24	
6.0	MFL 6 B1.0 L22	2.0	.87	.04	.06	.11	.31	SIM ... H6
	MFL 6 B1.5 L22	2.0	.87	.06	.10	.11	.31	
	MFL 6 B2.0 L22	2.0	.87	.08	.12	.11	.31	
	MFL 6 B2.5 L22	2.0	.87	.10	.19	.11	.31	
	MFL 6 B3.0 L30	2.3	1.18	.12	.24	.11	.31	
8.0	MFL 8 B2.5 L22	2.5	.87	.10	.14	.15	.39	SIM ... H8

Order example: MFL 6 B1.0 L22 BXC

* For additional holders see pages 106-111

MVR Bars Deep Face Grooving - with 2 Coolant Bores

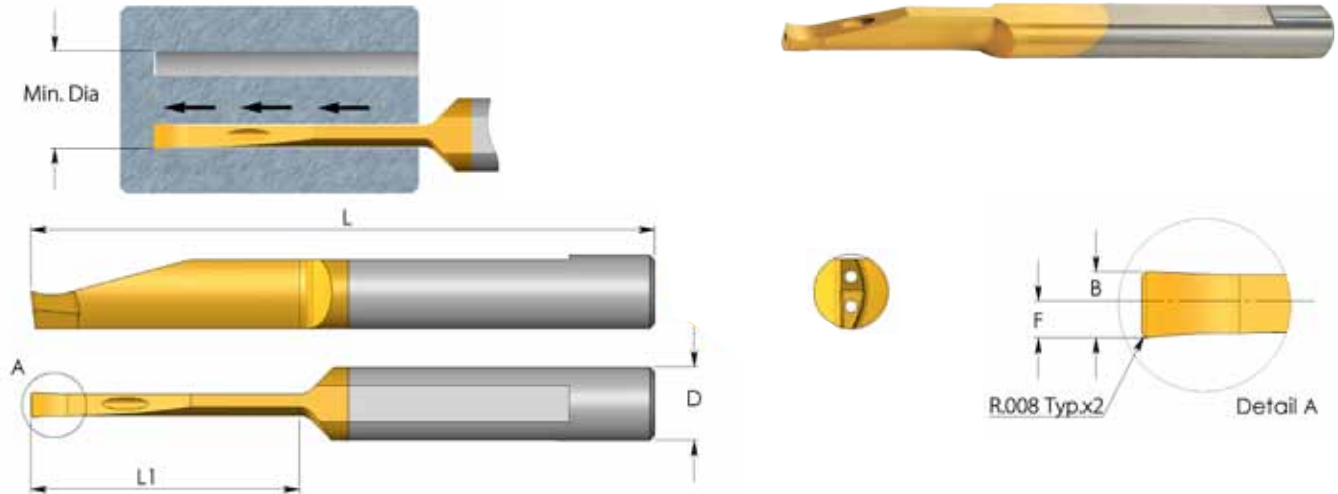

D mm	Ordering Code	L	L1	B	F	Min. Dia.	Holder*
6.0	MVR 6 B2.0 L10	2.5	.39	.08	.04	.39	SIM ... H6
	MVR 6 B2.0 L15	2.5	.59	.08	.04	.47	
	MVR 6 B2.0 L22	2.5	.87	.08	.04	.47	
	MVR 6 B2.5 L15	2.5	.59	.10	.06	.39	
	MVR 6 B2.5 L22	2.5	.87	.10	.06	.47	
	MVR 6 B3.0 L20	2.5	.79	.12	.06	.39	
8.0	MVR 8 B3.0 L27	2.5	1.06	.12	.06	.59	SIM ... H8
	MVR 8 B3.0 L43	3.1	1.69	.12	.06	.59	
8.0	MVR 8 B4.0 L43	3.1	1.69	.16	.08	.79	SIM ... H8

Order example: MVR 6 B2.0 L22 BXC

* For additional holders see pages 106-111

For L.H. bars specify **MVL** instead of **MVR**

MZR Bars Face Grooving

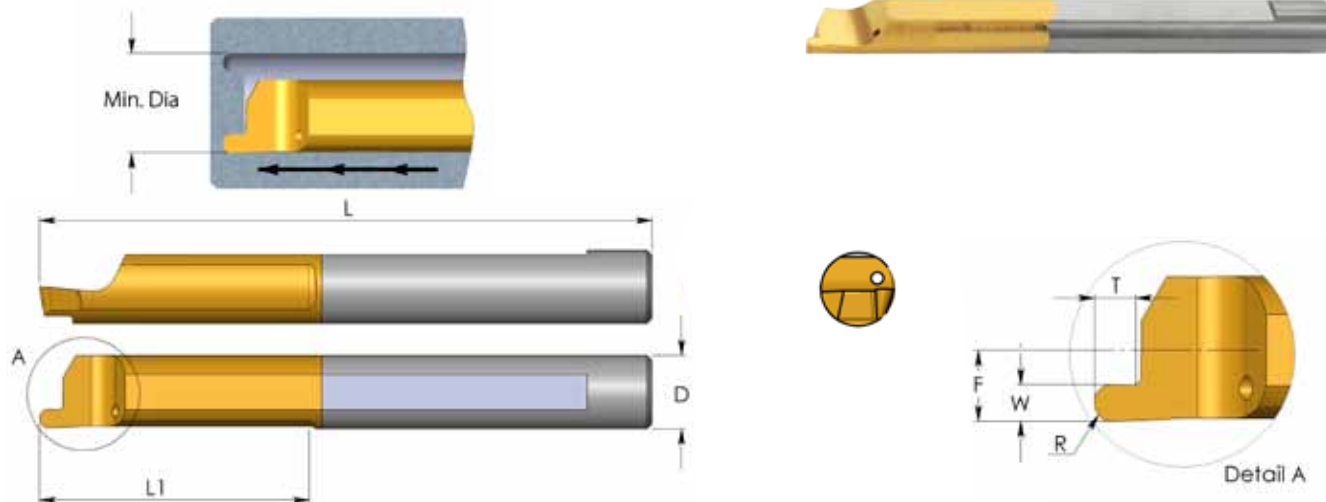

D mm	Ordering Code	L	L1	R	W	T	F	Min. Dia.	Holder*
4.0	MZR 4 R0.5 L15	2.0	.59	.020	.04	.05	.08	.20	SIM ... H4
	MZR 4 R0.75 L15	2.0	.59	.030	.06	.06	.08	.20	
5.0	MZR 5 R0.5 L22	2.0	.87	.020	.04	.05	.10	.24	SIM ... H5
	MZR 5 R0.75 L22	2.0	.87	.030	.06	.06	.10	.24	
	MZR 5 R1.0 L22	2.0	.87	.039	.08	.10	.10	.24	
6.0	MZR 6 R0.5 L22	2.0	.87	.020	.04	.05	.12	.31	SIM ... H6
	MZR 6 R0.75 L22	2.0	.87	.030	.06	.06	.12	.31	
	MZR 6 R1.0 L22	2.0	.87	.039	.08	.10	.12	.31	

Order example: MZR 5 R0.5 L22 BXC

* For additional holders see pages 106-111

MZL Bars Face Grooving

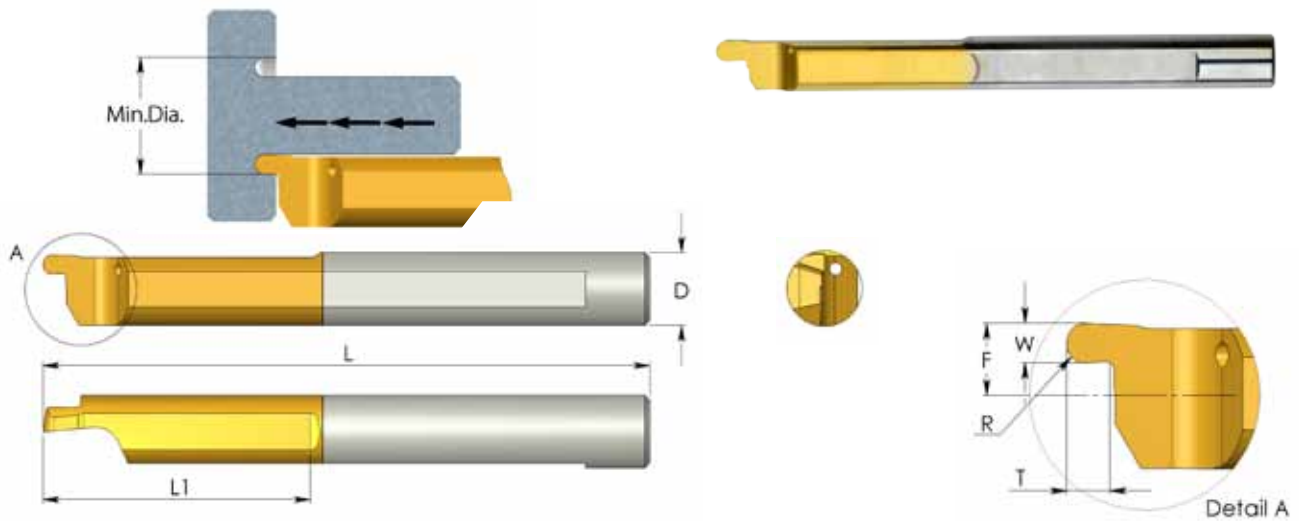

D mm	Ordering Code	L	L1	R	W	T	F	Min. Dia.	Holder*
4.0	MZL 4 R0.5 L15	2.0	.59	.020	.04	.05	.07	.20	SIM ... H4
	MZL 4 R0.75 L15	2.0	.59	.030	.06	.06	.07	.20	
5.0	MZL 5 R0.5 L22	2.0	.87	.020	.04	.05	.09	.24	SIM ... H5
	MZL 5 R0.75 L22	2.0	.87	.030	.06	.06	.09	.24	
	MZL 5 R1.0 L22	2.0	.87	.039	.08	.10	.09	.24	
6.0	MZL 6 R0.5 L22	2.0	.87	.020	.04	.05	.11	.31	SIM ... H6
	MZL 6 R0.75 L22	2.0	.87	.030	.06	.06	.11	.31	
	MZL 6 R1.0 L22	2.0	.87	.039	.08	.10	.11	.31	

Order example: MZL 5 R0.5 L22 BXC

* For additional holders see page 106-111

CMR Carmex Multi-Task Tiny Tools

Multi-Task Tiny Tool CMR for Boring, Turning, Facing and Chamfering with a single tool.

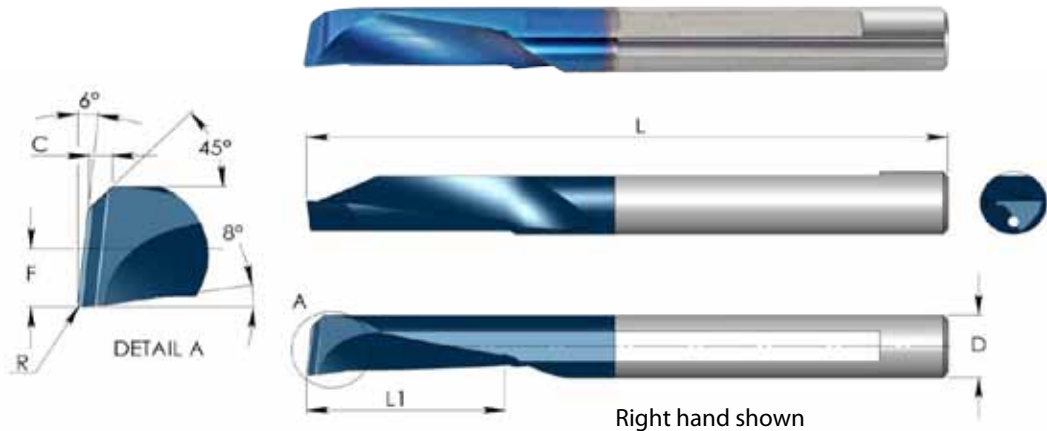

Right hand

D mm	Ordering Code	L	L1	R	F	C	Hole Dia.*	Holder **	P	M	K	N	S	H
4.0	CMR 4 R0.1 L10	2.0	.39	.004	.07	.04	.16	SIM...H4	BMK	*				
	CMR 4 R0.1 L15	2.0	.59	.004	.07	.04	.16			*				
5.0	CMR 5 R0.2 L10	2.0	.39	.008	.09	.05	.20	SIM...H5		*				
	CMR 5 R0.2 L15	2.0	.59	.008	.09	.05	.20			*				
6.0	CMR 6 R0.2 L12	2.3	.47	.008	.11	.06	.24	SIM...H6						
	CMR 6 R0.2 L18	2.3	.71	.008	.11	.06	.24							

Left hand

D mm	Ordering Code	L	L1	R	F	C	Hole Dia.*	Holder **	P	M	K	N	S	H
4.0	CML 4 R0.1 L10	2.0	.39	.004	.07	.04	.16	SIM...H4	BMK	*				
	CML 4 R0.1 L15	2.0	.59	.004	.07	.04	.16			*				
5.0	CML 5 R0.2 L10	2.0	.39	.008	.09	.05	.20	SIM...H5		*				
	CML 5 R0.2 L15	2.0	.59	.008	.09	.05	.20			*				
6.0	CML 6 R0.2 L12	2.3	.47	.008	.11	.06	.24	SIM...H6						
	CML 6 R0.2 L18	2.3	.71	.008	.11	.06	.24							

* The minimum diameter the tool can produce from full material

** For additional holders see page 106-111

CBR Bars Profiling and Boring

With advanced Chip Breaker

Chip evacuation is obtained thanks to advanced Chip Breaker and the internal coolant through the tool, pushing the chips out of the hole.

Excellent Solution for machining stainless steels, super alloys and other “difficult” materials that creates curly chips around the tool and the application. Can be used also as general purpose for a wide range of materials.

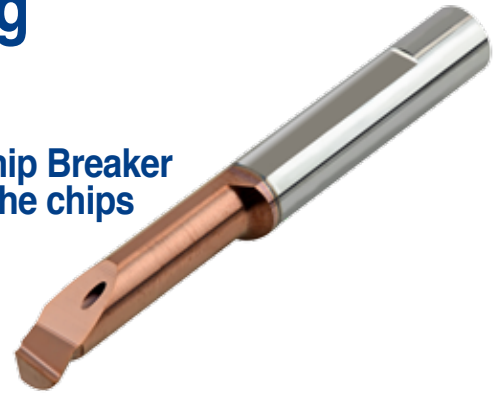

Carbide grade:

New advanced carbide grade **TNX** for higher feeds and high performance, at medium to high cutting speed. Extra fine grain size with high hardness and toughness combined with triple layer reddish coating, provides high edge stability and better chip flow.

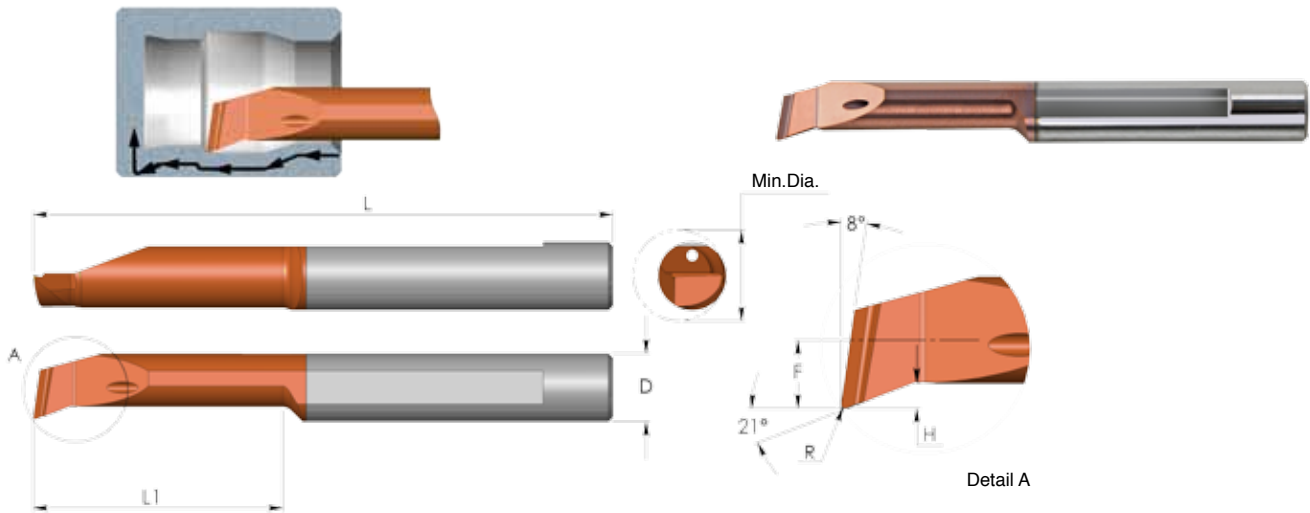

D mm	Ordering Code	L	L1	R	H	F	Min. Dia.	Holder
4.0	CBR 4 R0.2 L10	2	.39	.008	.02	.07	.16	SIM ... H4
	CBR 4 R0.2 L15	2	.59	.008	.02	.07	.16	
5.0	CBR 5 R0.2 L15	2	.59	.008	.03	.09	.20	SIM ... H5
	CBR 5 R0.2 L22	2	.87	.008	.03	.09	.20	
6.0	CBR 6 R0.2 L15	2	.59	.008	.04	.11	.24	SIM ... H6
	CBR 6 R0.2 L22	2	.87	.008	.04	.11	.24	

P	TNX	*
M		*
K		*
N		*
S		*
H		*

For L.H. bars specify CBL instead of CBR

Product Identification

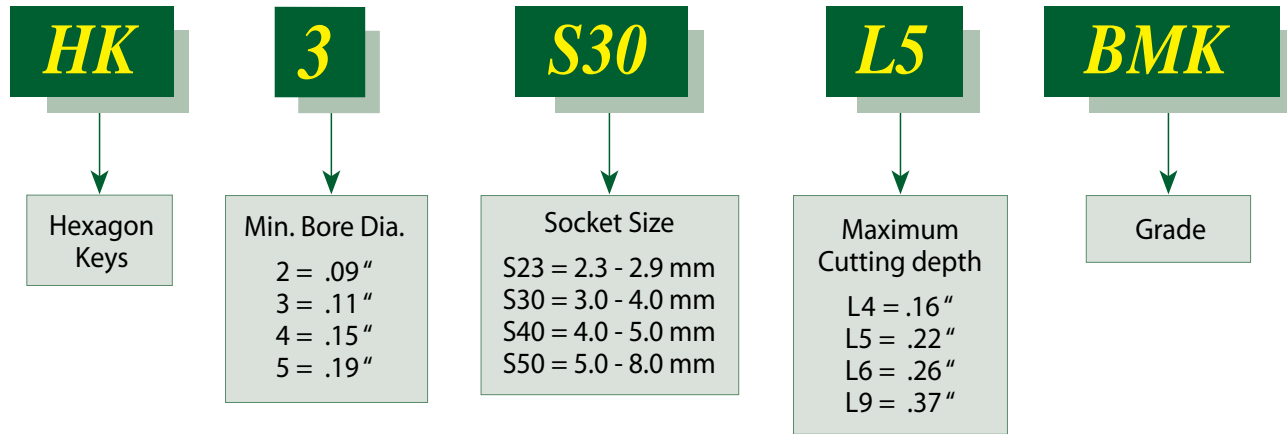

HK Broaching Tools for Hexagon Keys

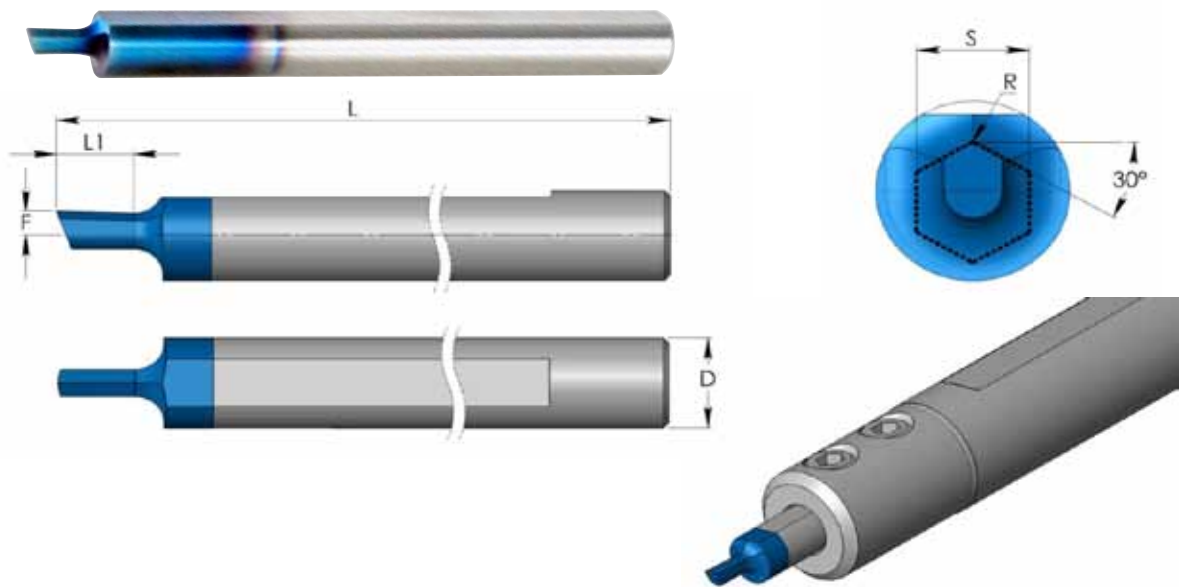

D mm	S mm	Ordering Code	L	L1	R	F	Min. Dia.	Holder
5.0	2.3-2.9	HK 2 S23 L4	2.0	.16	.002	.05	.09	SIM...H5
	3.0-4.0	HK 3 S30 L5	2.0	.22	.002	.05	.11	
	4.0-5.0	HK 4 S40 L6	2.0	.26	.004	.05	.15	
7.0	5.0-8.0	HK 5 S50 L9	2.4	.37	.004	.05	.19	SIM...H7

P	BMK	*
M		*
K		*
N		*
S		*
H		

S = Socket Size

* For additional holders see page 106-111

Product Identification

Tiny Bar Holders Ordering Codes

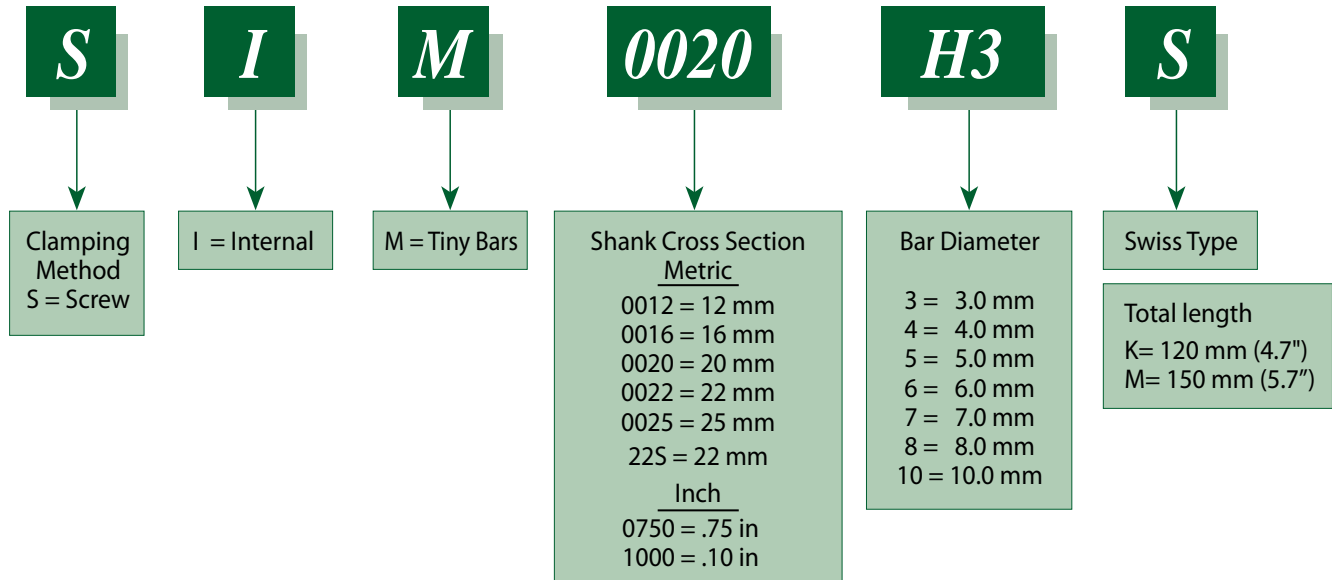

Tiny Tools Bar Holders

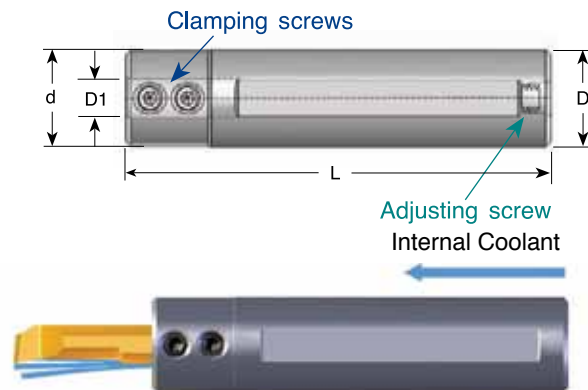

Metric Shank Version

D1 mm	Ordering Code	D mm	d mm/in	L mm/in	Key	Clamping Screw	Adjusting Screw
3.0	SIM 0012 H3	12	12 / .47	88 / 3.5	K25	S24	S35
	SIM 0016 H3S	16	20 / .79	75 / 3.0	K25	S25	S35S
	SIM 0016 H3	16	20 / .79	88 / 3.5	K25	S25	S35
	SIM 0020 H3	20	20 / .79	88 / 3.5	K25	S25	S35
	SIM 0022 H3	22	22 / .87	88 / 3.5	K25	S25	S35
	SIM0022 H3K	22	22 / .87	120 / 4.7	K25	S25	S55
	SIM0025 H3M	25	25 / .98	150 / 5.9	K25	S25	-

Tiny Tools Bar Holders

D1 mm	Ordering Code	D mm	d mm/in	L mm/in	Key	Clamping Screw	Adjusting Screw
4.0	SIM 0012 H4	12	12 / .47	88 / 3.5	K25	S24	S35
	SIM 0016 H4S	16	20 / .79	75 / 3.0	K25	S25	S35S
	SIM 0016 H4	16	20 / .79	88 / 3.5	K25	S25	S35
	SIM 0020 H4	20	20 / .79	88 / 3.5	K25	S25	S35
	SIM 0022 H4	22	22 / .87	88 / 3.5	K25	S25	S35
	SIM0022 H4K	22	22 / .87	120 / 4.7	K25	S25	S55
	SIM0025 H4M	25	25 / .98	150 / 5.9	K25	S25	-
5.0	SIM 0012 H5	12	12 / .47	88 / 3.5	K25	S24	S35
	SIM 0016 H5S	16	20 / .79	75 / 3.0	K25	S25	S35S
	SIM 0016 H5	16	20 / .79	88 / 3.5	K25	S25	S35
	SIM 0020 H5	20	20 / .79	88 / 3.5	K25	S25	S35
	SIM 0022 H5	22	22 / .87	88 / 3.0	K25	S25	S35
	SIM0022 H5K	22	22 / .87	120 / 4.7	K25	S25	S55
	SIM0025 H5M	25	25 / .98	150 / 5.9	K25	S25	-
6.0	SIM 0016 H6S	16	20 / .79	75 / 3.0	K25	S25	S35S
	SIM 0016 H6	16	20 / .79	88 / 3.5	K25	S25	S35
	SIM 0020 H6	20	20 / .79	88 / 3.5	K25	S25	S35
	SIM 0022 H6	22	22 / .87	88 / 3.5	K25	S25	S35
	SIM0022 H6K	22	22 / .87	120 / 4.7	K25	S25	S55
	SIM0025 H6M	25	25 / .98	150 / 5.9	K25	S25	-
7.0	SIM 0016 H7	16	20 / .79	88 / 3.5	K25	S25	S35
	SIM 0020 H7	20	20 / .79	88 / 3.5	K25	S25	S35
	SIM0022 H7	22	22 / .87	88 / 3.5	K25	S25	S35
8.0	SIM 0016 H8	16	20 / .79	88 / 3.5	K25	S25	S35
	SIM 0020 H8	20	20 / .79	88 / 3.5	K25	S25	S35
	SIM0022 H8	22	22 / .87	88 / 3.5	K25	S25	S35
10.0	SIM0016 H10	16	20 / .79	88 / 3.5	K25	S25S	S35
	SIM 0020 H10	20	20 / .79	88 / 3.5	K25	S25S	S35
	SIM0022 H10	22	22 / .87	88 / 3.5	K25	S25	S35

Inch Shank Version

D1 mm	Ordering Code	D in	d mm/in	L mm/in	Key	Clamping Screw	Adjusting Screw
3.0	SIM 0750 H3	3/4	19.05 / .75	88 / 3.5	K25	S25	S35
	SIM 1000 H3	1	25.4 / 1.0	88 / 3.5	K25	S25	S35
4.0	SIM 0750 H4	3/4	19.05 / .75	88 / 3.5	K25	S25	S35
	SIM 1000 H4	1	25.4 / 1.0	88 / 3.5	K25	S25	S35
5.0	SIM 0750 H5	3/4	19.05 / .75	88 / 3.5	K25	S25	S35
	SIM 1000 H5	1	25.4 / 1.0	88 / 3.5	K25	S25	S35
6.0	SIM 0750 H6	3/4	19.05 / .75	88 / 3.5	K25	S25	S35
	SIM 1000 H6	1	25.4 / 1.0	88 / 3.5	K25	S25	S35
7.0	SIM 0750 H7	3/4	19.05 / .75	88 / 3.5	K25	S25	S35
	SIM 1000 H7	1	25.4 / 1.0	88 / 3.5	K25	S25	S35
8.0	SIM 0750 H8	3/4	19.05 / .75	88 / 3.5	K25	S25	S35
	SIM0750 H10	3/4	19.05 / .75	88 / 3.5	K25	S25S	S35
10.0	SIM1000 H10	1	25.4 / 1.0	88 / 3.5	K25	S25	S35

Tiny Tools Bar Holders

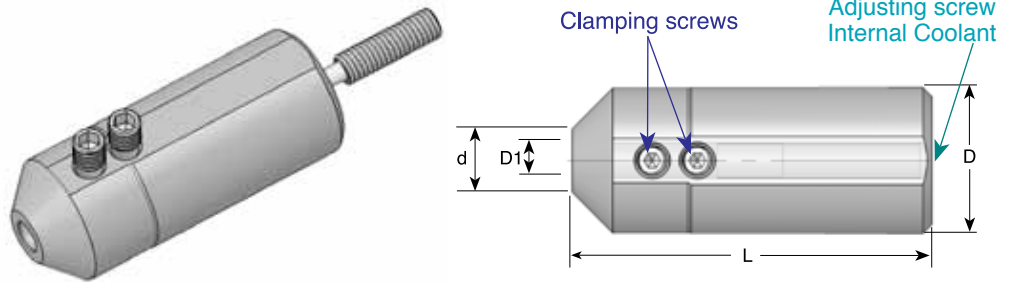

Metric shank version

D1 mm	Ordering Code	D mm	d mm/in	L mm/in	Key	Clamping Screw	Adjusting Screw
3.0	SIM 0025 H3	25	10.8 / .43	62 / 2.4	K25	S25	S35M
4.0	SIM 0025 H4	25	10.8 / .43	62 / 2.4	K25	S25	S35M
5.0	SIM 0025 H5	25	10.8 / .43	62 / 2.4	K25	S25	S35M
6.0	SIM 0025 H6	25	10.8 / .43	62 / 2.4	K25	S25	S35M
7.0	SIM 0025 H7	25	10.8 / .43	62 / 2.4	K25	S25	S35M
8.0	SIM 0025 H8	25	10.8 / .43	62 / 2.4	K25	S25	S35M

Tiny Toolholder for Swiss machines

Carmex has developed a unique external turning holder for the sub-spindle on CNC Swiss type lathes.

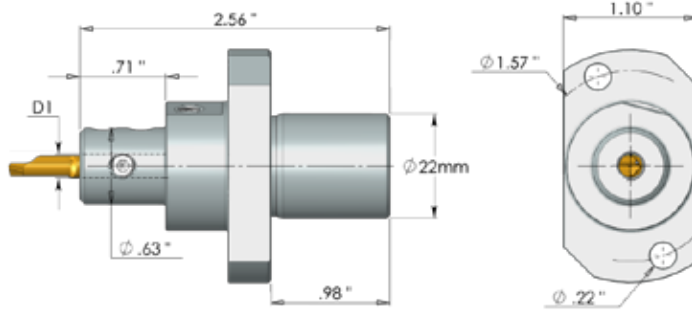

Tiny Toolholder

D1 mm	Ordering Code	dp mm	Key	Clamping Screw
3.0	SIM 22S H3	4 / 6	K16	S24P
4.0	SIM 22S H4	4 / 6	K16	S24P
5.0	SIM 22S H5	4 / 6	K16	S24M
6.0	SIM 22S H6	4 / 6	K16	S24M

To use on Star machines

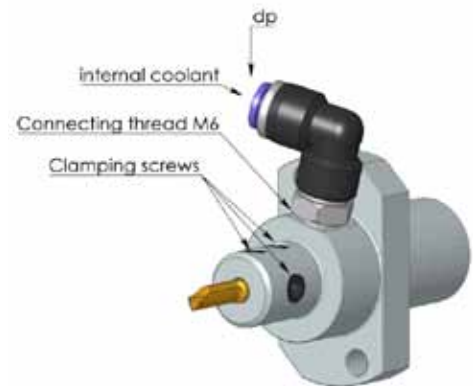
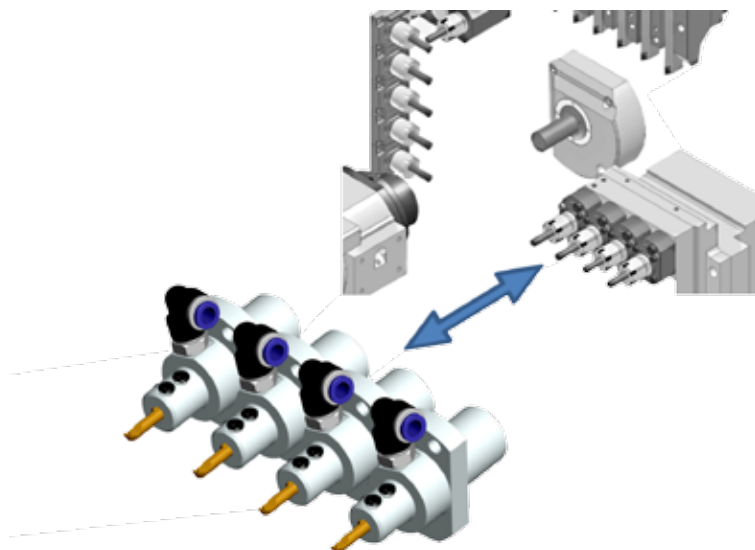

Product Identification

Tiny Bar Square Shank Holders Ordering Codes

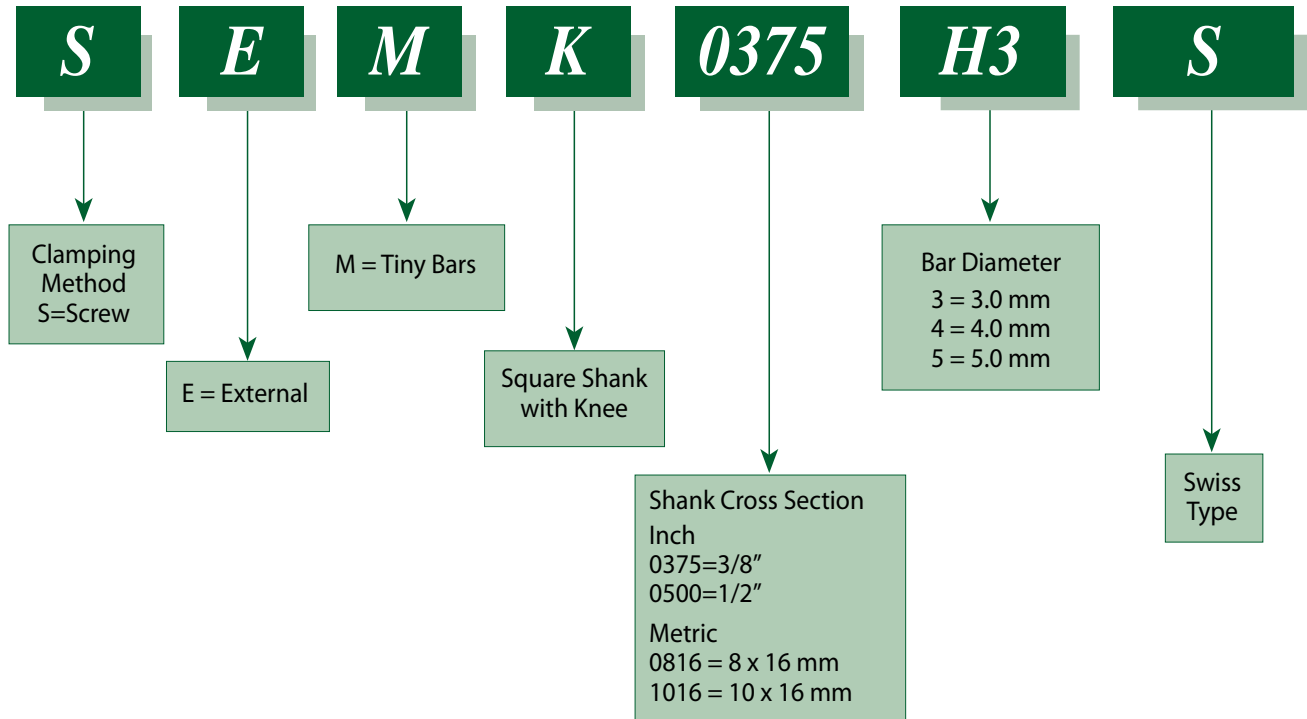

Square Shank Holders

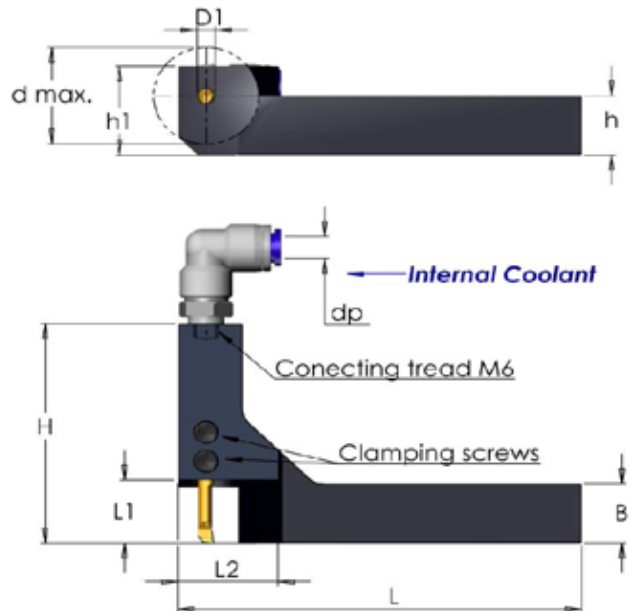

Inch Holders

D1 mm	Ordering Code	B	L	L1	L2	H	h	h1	d max.	*dp mm	Key	Clamping Screw
3.0	SEMK 0375 H3S	.375	3.9	.67	.98	1.81	.375	.69	1.02	4/6	K25	S25
	SEMK 0500 H3S	.500	3.9	.67	.98	1.81	.500	.81	1.02	4/6	K25	
4.0	SEMK 0375 H4S	.375	3.9	.67	.98	2.28	.375	.68	1.02	4/6	K25	S25
	SEMK 0500 H4S	.500	3.9	.67	.98	2.28	.500	.81	1.02	4/6	K25	
5.0	SEMK 0375 H5S	.375	3.9	.67	.98	2.28	.375	.68	1.02	4/6	K25	S25
	SEMK 0500 H5S	.500	3.9	.67	.98	2.28	.500	.81	1.02	4/6	K25	
6.0	SEMK 0375 H6S	.375	3.9	.67	.98	2.28	.375	.68	1.02	4/6	K25	S25
	SEMK 0500 H6S	.500	3.9	.67	.98	2.28	.500	.81	1.02	4/6	K25	

Metric Holders

D1 mm	Ordering Code	B mm	L mm/in	L1 mm/in	L2 mm/in	H mm/in	h mm/in	h1 mm/in	d max. mm/in	*dp mm	Key	Clamping Screw
3.0	SEMK 0816 H3S	16	100/ 3.9	17/1.67	25/1.98	46/1.81	8	16/1.63	26/1.02	4/6	K25	S25
	SEMK 1016 H3S	16	100/ 3.9	17/1.67	25/1.98	46/1.81	10	18/1.71	26/1.02	4/6	K25	
	SEMK 1216 H3S	16	100/ 3.9	17/1.67	25/1.98	46/1.81	12	20/1.79	26/1.02	4/6	K25	
4.0	SEMK 0816 H4S	16	100/ 3.9	17/1.67	25/1.98	58/2.28	8	16/1.63	26/1.02	4/6	K25	S25
	SEMK 1016 H4S	16	100/ 3.9	17/1.67	25/1.98	58/2.28	10	18/1.71	26/1.02	4/6	K25	
	SEMK 1216 H4S	16	100/ 3.9	17/1.67	25/1.98	58/2.28	12	20/1.79	26/1.02	4/6	K25	
5.0	SEMK 0816 H5S	16	100/ 3.9	17/1.67	25/1.98	58/2.28	8	16/1.63	26/1.02	4/6	K25	S25
	SEMK 1016 H5S	16	100/ 3.9	17/1.67	25/1.98	58/2.28	10	18/1.71	26/1.02	4/6	K25	
	SEMK 1216 H5S	16	100/ 3.9	17/1.67	25/1.98	58/2.28	12	20/1.79	26/1.02	4/6	K25	
6.0	SEMK 0816 H6S	16	100/ 3.9	17/1.67	25/1.98	58/2.28	8	16/1.63	26/1.02	4/6	K25	S25
	SEMK 1016 H6S	16	100/ 3.9	17/1.67	25/1.98	58/2.28	10	18/1.71	26/1.02	4/6	K25	
	SEMK 1216 H6S	16	100/ 3.9	17/1.67	25/1.98	58/2.28	12	20/1.79	26/1.02	4/6	K25	

* Optional

Tiny Tools Kits

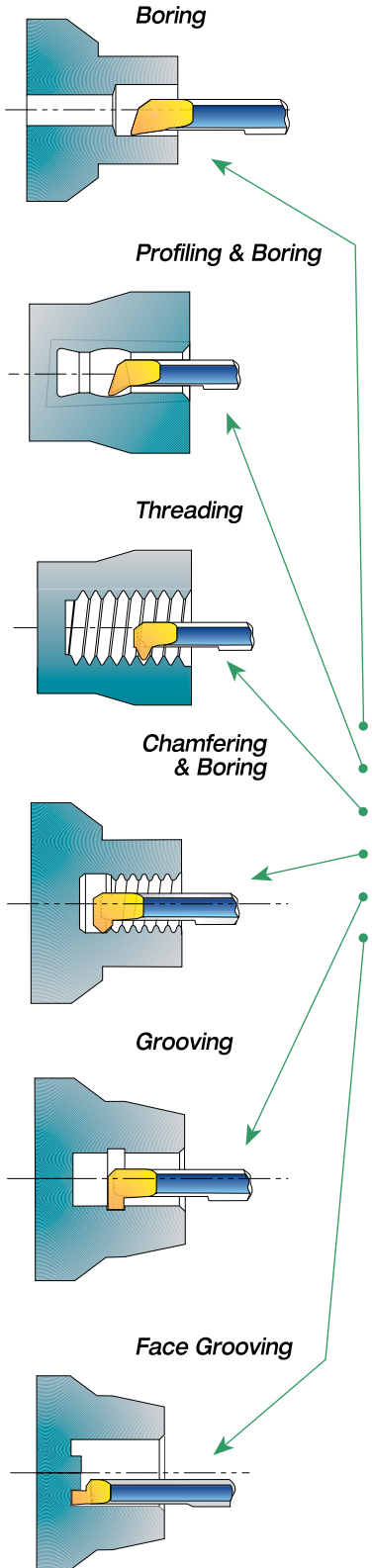

KT4-0750	KT5-0750
MTR 4 R0.2 L10	MTR 5 R0.2 L15
MPR 4 R0.2 L10	MPR 5 R0.2 L15
MIR 4 L15 A60	MIR 5 L15 A60
MCR4 R0.2 L15	MCR 5 R0.2 L15
MGR4 B1.5 L10	MGR 5 B1.5 L15
MFR 4 B1.0 L15	MFR 5 B1.0 L22
SIM 0750 H4	SIM 0750 H5
K25	K25

-  Boring
-  Profiling
-  Threading
-  Chamfering
-  Grooving
-  Face Grooving

Tiny Tools Bar Holder

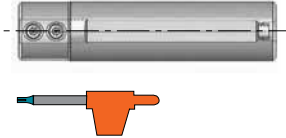

Order example: KT4-0750

Also available kits with metric shank diameter bar holder.
Order example: KT4-16

Technical Section

Carbide Grades:

BXC (P30 - P50, K25 - K40)

PVD TiN coated grade for low cutting speed.
Works well with a wide range of stainless steels.

BMK (K10 - K20)

Sub-micron grade with advanced PVD triple coating. Extremely high heat resistant and smooth cutting operation, for high performance, and normal machining conditions. General purpose for all materials.

K20 (K10 - K30)

Uncoated Carbide grade for non ferrous metals, aluminum and cast iron.

TNX

New advanced carbide grade **TNX** for higher feeds and high performance, at medium to high cutting speed. Extra fine grain size with high hardness and toughness combined with triple layer reddish coating, provides high edge stability and better chip flow.



Cutting speed for Tiny Tools

ISO Standard	Material		Condition	Cutting Speed ft/min			
				BXC	BMK	K20	TNX
P	Non-Alloy steel and cast steel, free cutting steel	<0.25%C	Annealed	82-230	98-262		118-262
		≥0.25%C	Annealed				
		<0.55%C	Quenched and tempered				
		≥0.55%C	Annealed				
	Low alloy steel and cast steel (less than 5% alloying elements)		Quenched and tempered	66-131	82-164		98-164
			Annealed				
High alloy steel, cast steel, and tool steel		Annealed	66-131	82-164		98-164	
		Quenched and tempered					
M	Stainless steel and cast steel		Ferritic/martensitic	82-131	98-197		118-197
			Martensitic				
			Austenitic				
K	Cast iron nodular (GGG)		Ferritic/pearlitic	82-197	98-262		118-262
			Pearlitic				
	Grey cast iron (GG)		Ferritic	98-230	98-262		118-262
			Pearlitic				
	Malleable cast iron		Ferritic	66-131	66-164		79-164
			Pearlitic				
N	Aluminum-wrought alloy		Not cureable	164-328	197-394	98-164	236-394
			Cured				
	Aluminum-cast, alloyed	<=12% Si	Not cureable	131-262	164-295	66-131	197-295
			Cured				
			High temperature				
	Copper alloys	>1% Pb	Free cutting	98-197	98-230	66-131	118-230
			Brass				
			Electrolytic copper				
Non metallic		Duroplastics, fiber plastics	131-262			66-131	
		Hard rubber					
S	High temp. alloys, Super alloys	Fe based	Annealed	49-98	49-131		59-131
			Cured				
		Ni or Co based	Annealed				
			Cured				
	Titanium alloys		Cast	33-98	33-98		39-98
			Alpha+beta alloys cured				
H	Hardened steel		Hardened 45-50 HRc	33-98	49-131		59-131
			Hardened 51-55 HRc				
			Hardened 56-62 HRc				
	Chilled cast iron		Cast	33-98	33-98		39-98
Cast iron		Hardened	33-66	33-66		39-66	

Recommended Feed Rate: .0005 - .001 inch/rev

Threading Passes

Pitch:	mm	0.5	0.7	0.8	1.0	1.25	1.5	2-5
	TPI	48	36	32	24	20	16	14-5
Number of Passes		6-12	7-14	7-16	8-18	8-20	10-22	20-38

CMR Carmex Multi-Task Tiny Tools

- Carmex is introducing a new and innovative Multi-Task Tiny Tool **CMR** for Boring, Turning, Facing and Chamfering with a single tool.
- The unique design enables machining of the material without the need for a pilot hole.
- The new tool shortens the machining cycle time and the number of tools required - providing **High Productivity**.
- Effective through coolant hole with a spiral flute, evacuates the chips out of the hole uninterruptedly.
- Unique chip breaker and flute design.
- To use with standard SIM toolholders on Swiss Type or CNC lathe machines.
- Available in **BMK** Grade only.

Working Method

- The tool penetrates the work piece and produces the hole compliant with the minimum diameter the tool allows.
- The tool can penetrate the material in one pass or several passes depending on the work piece material, coolant pressure, machine power etc.
- The hole can be enlarged by multi radial passes.

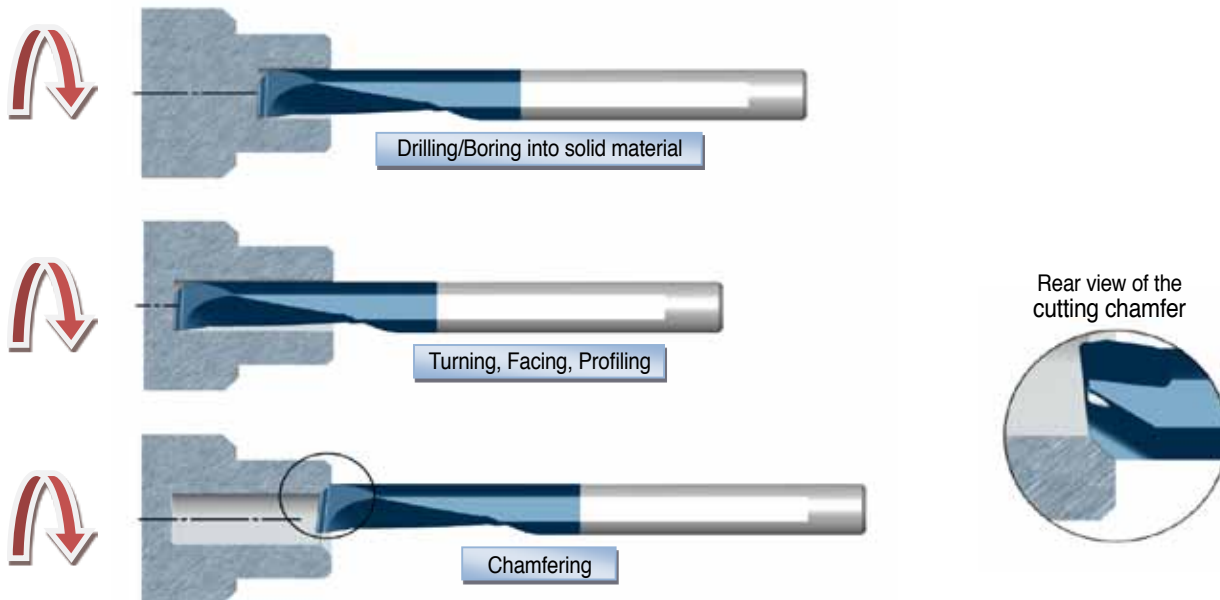

The tool is equipped with an additional cutting edge, which is located across the main front edge. This allows production of an additional 45° chamfer on the work piece without the need to stop the spindle or processing operation.

CMR Cutting Data and General Recommendations

Coolant fluid

Dry machining should not be performed under any circumstances. It is necessary to use an internal coolant in all applications. Oil or Emulsion lubricants are recommended for best performance. In the event of low coolant pressure, adding an external coolant can improve the tool operation.

The cooling stream is designed to provide three benefits:

1. Cooling the cutting edge of the tool, and the contact area.
2. Pushing the chip away from the tool quickly, thereby reducing wear of the edge.
3. Helping to break the chip into smaller pieces and evacuating them from the cutting area.

ISO Standard	Materials	Cutting Speed f/min
P	Low and Medium Carbon Steels <0.55%C	65-245
	High Carbon Steels ≥0.55%C	65-245
	Alloy Steels, Treated Steels	65-200
M	Stainless Steels - Free Cutting	65-200
	Stainless Steels - Austenitic	65-165
	Cast Steels	65-230
K	Cast Iron	65-330
N	Aluminum ≤12%Si, Copper	130-490
	Aluminum >12% Si	65-330
	Synthetics, Duroplastics, Thermoplastics	130-490
S	Nickel Alloys, Titanium Alloys	50-200
H	Hardened Steels	-

Recommended Feed Rate: .0005 - .001 inch/rev

HK Broaching Tools for Hexagon Keys

The HK broaching system have been developed to machine internal keyways inside blind or through holes, using CNC machines.

Working Demo

- To use with Carmex standard SIM Bar Holders
- The holder can be located directly in the turret or the machine spindle
- Holder with rear clamping screw for full support during operation
- Available in **BMK** Grade only.

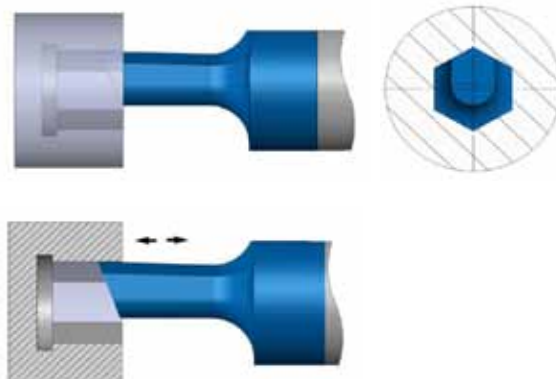

HK Cutting Data

Material Tensile Strength (lbs/in ²)	Feed rate (inch/min)	In feed per stroke (inch)
58.000-94.000	276-354	.0024-.0035
101.000-123.000	197-256	.0016-.0028
130.500-145.000	157-217	.0012-.0217
160.500-174.000	118-177	.0008-.0016

The cutting data above is an initial recommendation and depends on the machine condition, workpiece profile and the application clamping.

- A relief groove is highly recommended, if not possible a gradual volume decrease should be made at the end of the broaching groove.
- The HK tool must be position outside of the hole/groove before each stroke.
- After setup and first stroke, we recommend to observe the tool and the application to make sure no collision occurred.

Mini Tools



Vertical Inserts and Toolholders for threading, chamfering, grooving and turning

Advantages

- Carbide grade:** BLU-Sub-micron grade with advanced PVD triple layer coating delivering high heat resistance and smooth cutting operation.
- Carbide shank toolholder provides excellent vibration resistance.
 - Long reach.
 - Through coolant.
 - For threading, grooving, boring and chamfering.
 - Quick indexing.

Typical Applications:

- Long threads or applications requiring over-hang.
- Enables production of threads with large pitch/profile.
- Threading, grooving, boring, profiling and chamfering - It's possible to offer most of the Tiny Tools profiles on the insert.

Contents:	Page:	Contents:	Page:
Product Identification	118	Back Turning	122
Partial Profile 60°	119	Boring and Profiling	123
Partial Profile 55°	119	Boring, Profiling and Facing	123
ISO	120	Face Grooving	124
UN	120	Face Grooving Full Radius	125
Chamfering	121	Carbide Shank Toolholder	126
Grooving	121	Steel Toolholders	127
Full Radius Grooving	122	Technical Section	128

Product Identification

Mini Tools Ordering Code

Inserts

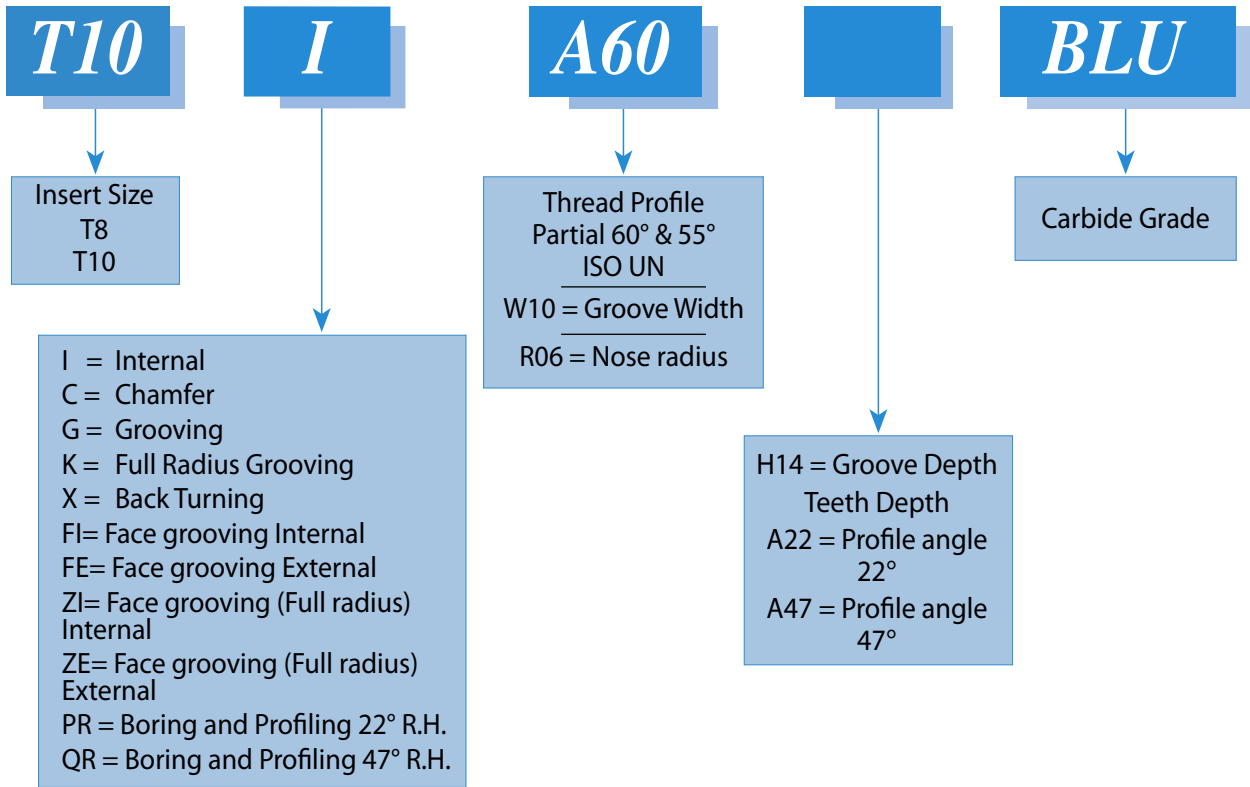

Toolholders

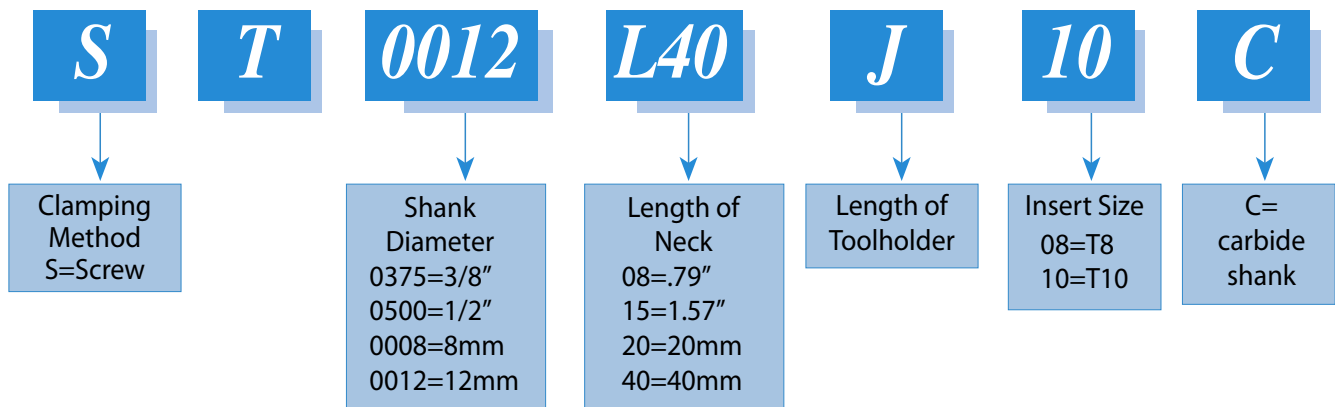

Partial Profile 60°

Same insert for internal and external thread

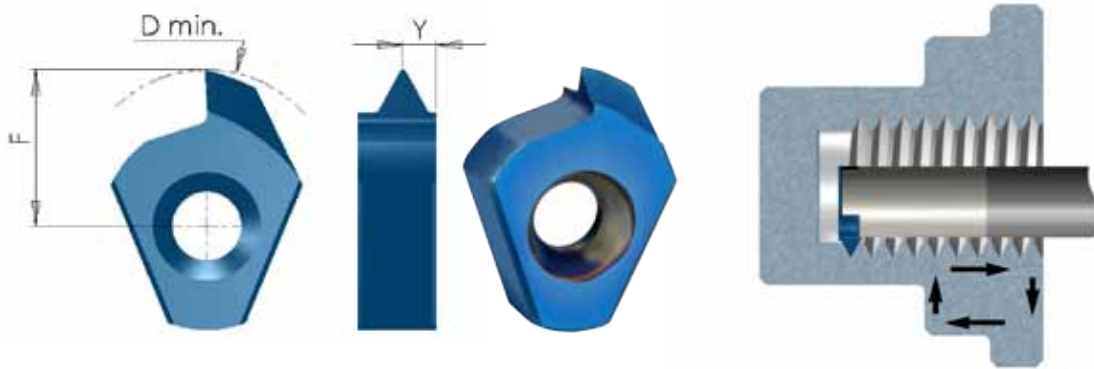

Insert Type	Ordering Code	Pitch Range mm	Pitch Range TPI	D min	F	Y
T8	T8 A60	Int 0.5-0.75 Ex 0.4- 0.75	56-32 64-32	.31	.15	.02
	T8 G60	Int 1.0-1.25 Ex 0.8- 1.0	28-20 32-28	.33	.16	.03
T10	T10 A60	Int 0.5-0.8 Ex 0.4-0.8	56-28 64-32	.46	.25	.02
	T10 G60	Int 1.0-2.0 Ex 0.8-1.75	28-13 32-15	.48	.28	.05
	T10 D60	Int 2.0-3.0 Ex 1.75-2.5	13-8 15-10	.52	.31	.06

Partial Profile 55°

Same insert for internal and external thread

Insert Type	Ordering Code	Pitch Range mm	Pitch Range TPI	D min	F	Y
T8	T8 G55	1.25-1.5	19-18	.36	.19	.04
	T8 U55	1.75-2.0	16-14	.34	.17	.05
T10	T10 G55	1.25-2.0	19-14	.49	.28	.05

Full Profile

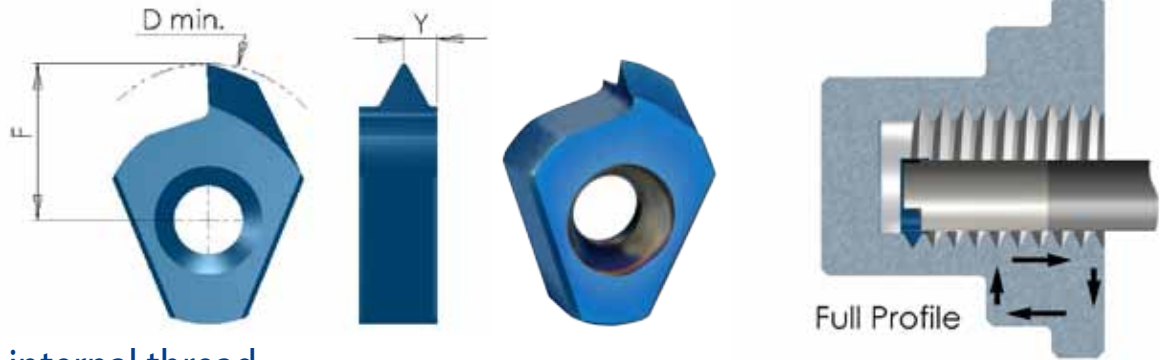

ISO

Inserts for internal thread

Insert Type	Ordering Code	Pitch mm	M coarse	M fine	D min	F	Y
T8	T8 I 0.5 ISO	0.5		M8.5	.31	.14	.02
	T8 I 0.75 ISO	0.75		M9	.32	.15	.02
	T8 I 1.0 ISO	1.0		M9	.31	.15	.03
	T8 I 1.25 ISO	1.25		M10	.32	.15	.03
	T8 I 1.5 ISO	1.5	M10	M12	.33	.16	.04
	T8 I 1.75 ISO	1.75	M12	-	.34	.17	.04
	T8 I 2.0 ISO	2.0	M14	M17	.35	.18	.05
T10	T10 I 0.5 ISO	0.5		M12	.44	.24	.02
	T10 I 0.75 ISO	0.75		M12	.44	.24	.02
	T10 I 1.0 ISO	1.0		M13	.46	.26	.03
	T10 I 1.5 ISO	1.5		M14	.46	.26	.04
	T10 I 2.0 ISO	2.0	M16	M17	.47	.27	.05
	T10 I 2.5 ISO	2.5	M18, M20	-	.50	.29	.06
	T10 I 3.0 ISO	3.0	M24	M28	.50	.29	.06

UN

Inserts for internal thread

Insert Type	Ordering Code	Pitch TPI	Nominal size	UNC	UNF	UNEF	D min	F	Y
T8	T8 I 32UN	32	7/16, 1/2			3/8	.33	.16	.02
	T8 I 28UN	28	3/8			7/16, 1/2	.33	.16	.03
	T8 I 24UN	24			3/8		.33	.16	.03
	T8 I 20UN	20	3/8		7/16, 1/2		.32	.15	.04
	T8 I 16UN	16	7/16, 1/2				.34	.17	.04
	T8 I 14UN	14		7/16			.35	.18	.05
	T8 I 13UN	13		1/2			.35	.18	.05
T10	T10 I 20UN	20	9/16, 5/8, 11/16			3/4	.47	.27	.04
	T10 I 18UN	18			9/16, 5/8		.47	.27	.04
	T10 I 16UN	16	9/16, 5/8, 11/16		3/4		.47	.27	.04
	T10 I 14UN	14			7/8		.48	.27	.05
	T10 I 12UN	12	5/8, 11/16, 3/4	9/16			.48	.27	.06
	T10 I 11UN	11		5/8			.49	.29	.06
	T10 I 10UN	10		3/4			.50	.29	.06

Chamfering

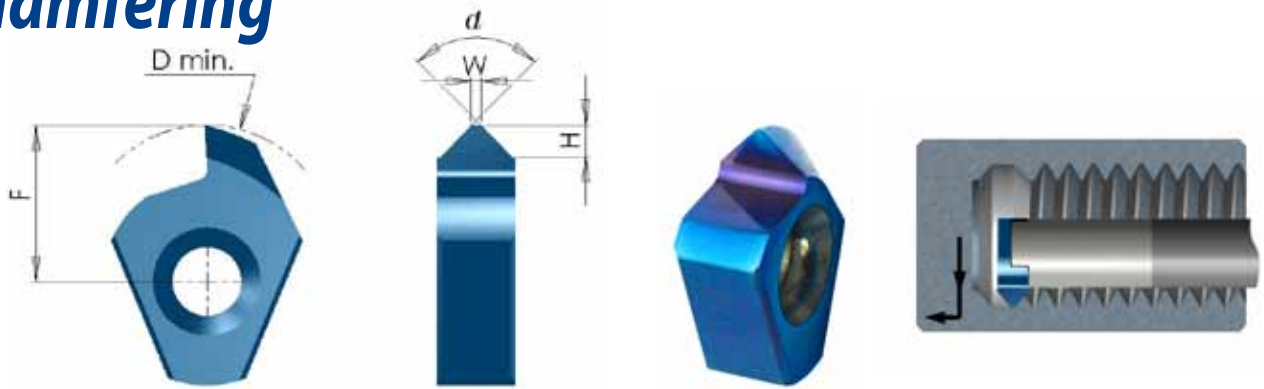

Insert Type	Ordering Code	W	H max	α	D min	F
T8	T8 C90	.01	.06	90°	.35	.18
T10	T10 C90	.01	.07	90°	.50	.30

Same insert for right and left hand chamfers

Grooving

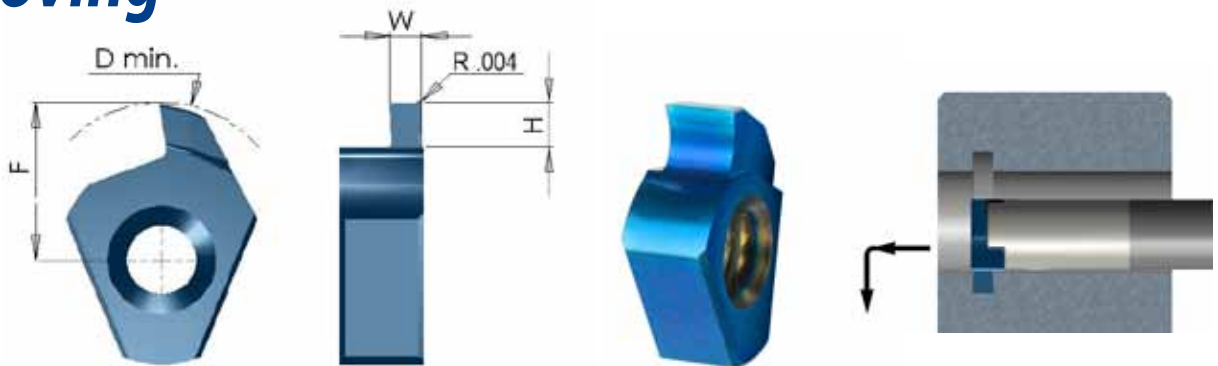

Insert Type	Ordering Code	W $\pm .001$	H max	D min	F
T8	T8 G W10 H20	.039	.08	.37	.20
	T8 G W15 H20	.059			
	T8 G W20 H20	.079			
	T8 G W25 H20	.098			
	T8 G W30 H20	.118			
T10	T10 G W10 H14	.039	.06	.48	.28
	T10 G W15 H14	.059			
	T10 G W20 H14	.079			
T10	T10 G W10 H23	.039	.09	.52	.31
	T10 G W15 H23	.059			
	T10 G W20 H23	.079			
	T10 G W25 H23	.098			
	T10 G W30 H23	.118			

Full Radius Grooving

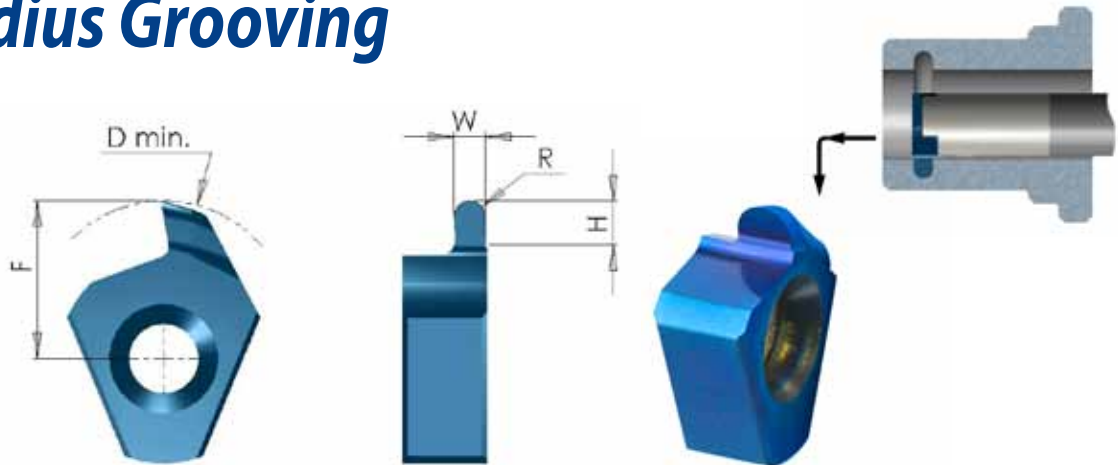

Insert Type	Ordering Code	W ± .001	R	H max	D min	F
T8	T8 K R04 H10	.031	.016	.04	.33	.16
	T8 K R06 H10	.047	.024			
	T8 K R09 H10	.071	.035			
T10	T10 K R04 H22	.031	.016	.09	.52	.31
	T10 K R06 H22	.047	.024			
	T10 K R09 H22	.071	.035			
	T10 K R10 H22	.079	.039			

Back Turning

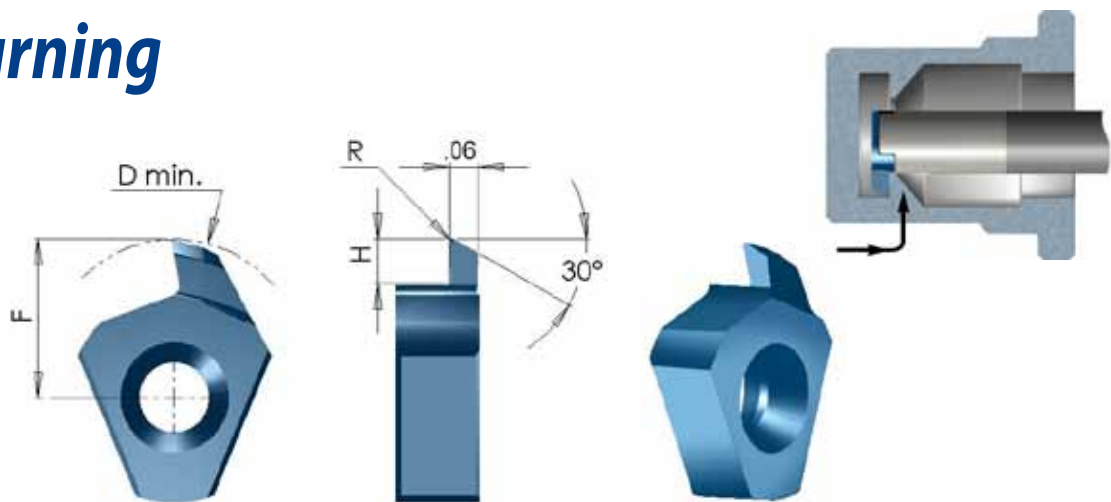

Insert Type	Ordering Code	R	H max	D min	F
T8	T8 X R02 H20	.008	.08	.37	.20
T10	T10 X R02 H23	.008	.09	.52	.31
	T10 X R04 H23	.016			

Boring and Profiling

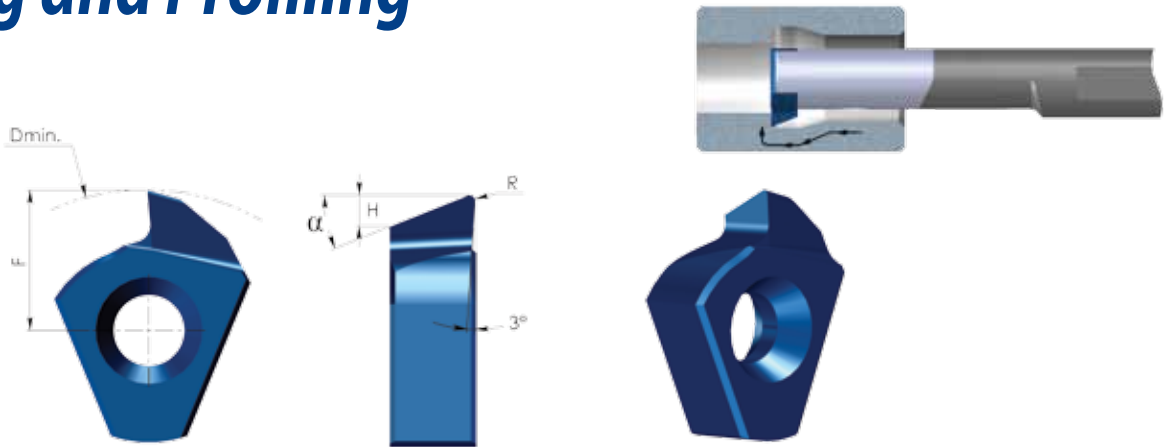

Insert Type	Ordering Code	α	R	H	D min	F
T8	T8 PR R01 A22	22°	.004	.039	.36	.20
	T8 PR R02 A22	22°	.008	.039	.36	.20
	T8 QR R01 A47	47°	.004	.075	.36	.20
	T8 QR R02 A47	47°	.008	.075	.36	.20

Boring, Profiling and Facing

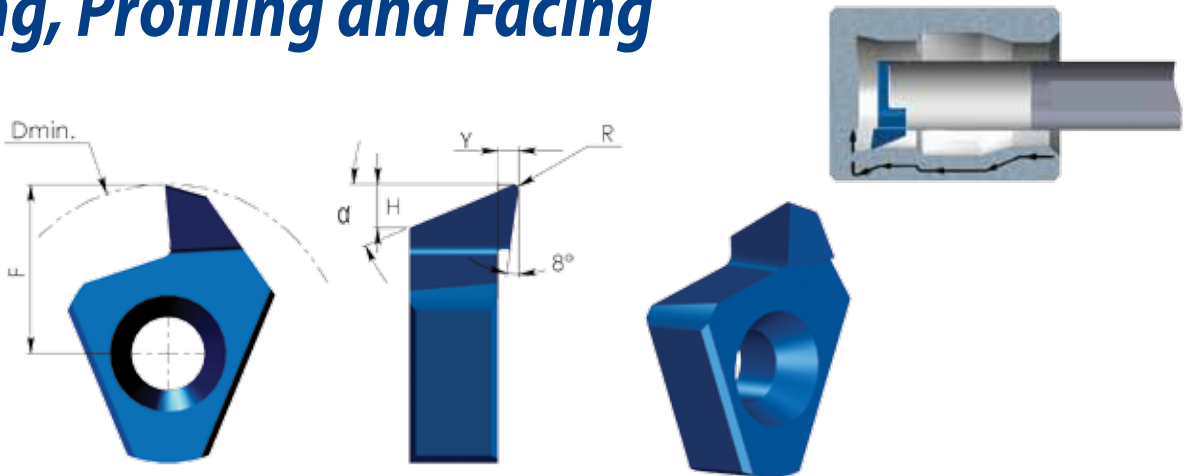

Insert Type	Ordering Code	α	β	R	H	Y	D min	F
T10	T10 PR R01 A22	22°	8°	.004	.075	.04	.51	.30
	T10 PR R02 A22	22°	8°	.008	.075	.04	.51	.30
	T10 QR R01 A47	47°	8°	.004	.102	.04	.51	.30
	T10 QR R02 A47	47°	8°	.008	.102	.02	.51	.30

Face Grooving Internal

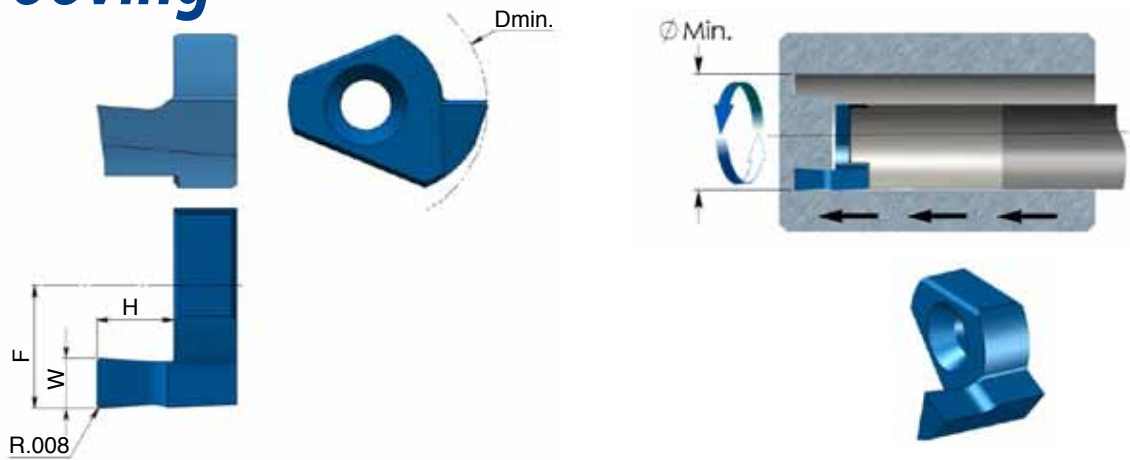

Insert Type	Ordering Code	W ± .001	H max	D min	F
T10	T10 FI W10 H15	.039	.06	.55	.31
	T10 FI W15 H25	.059	.10		
	T10 FI W20 H30	.079	.12		
	T10 FI W20 H50	.079	.20		
	T10 FI W25 H30	.098	.12		
	T10 FI W25 H50	.098	.20		
	T10 FI W30 H30	.118	.12		
	T10 FI W30 H50	.118	.20		

External

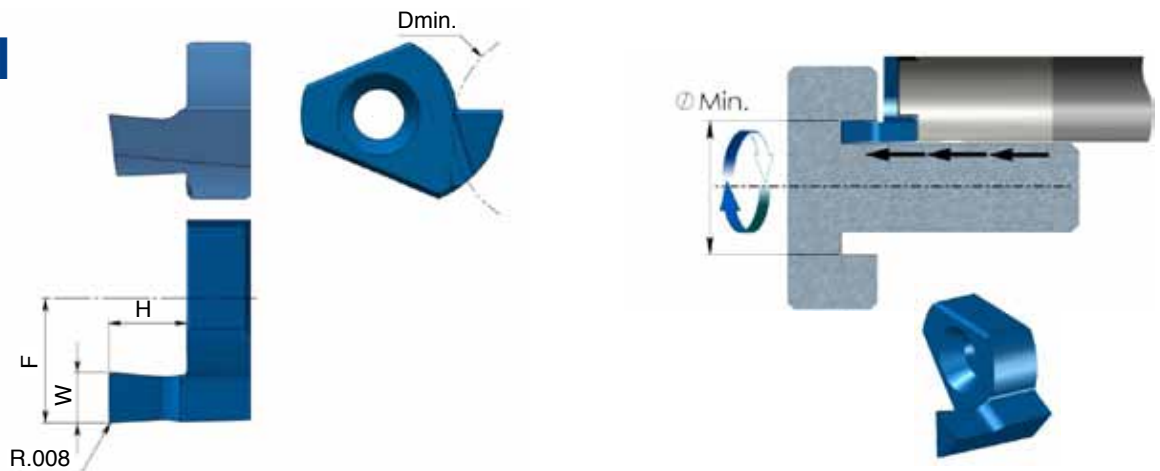

Insert Type	Ordering Code	W ± .001	H max	D min	F
T10	T10 FE W10 H15	.039	.06	.47	.31
	T10 FE W15 H25	.059	.10		
	T10 FE W20 H30	.079	.12		
	T10 FE W20 H50	.079	.20		
	T10 FE W25 H30	.098	.12		
	T10 FE W25 H50	.098	.20		
	T10 FE W30 H30	.118	.12		
	T10 FE W30 H50	.118	.20		

Face Grooving, Full Radius Internal

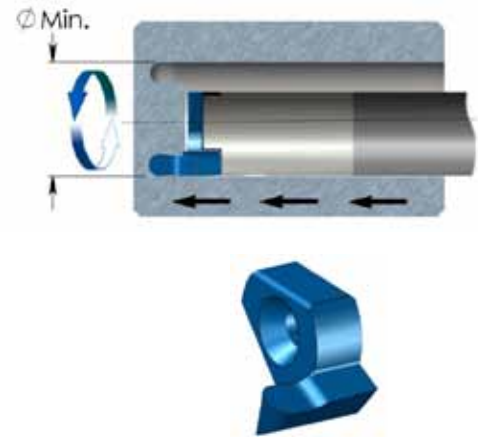
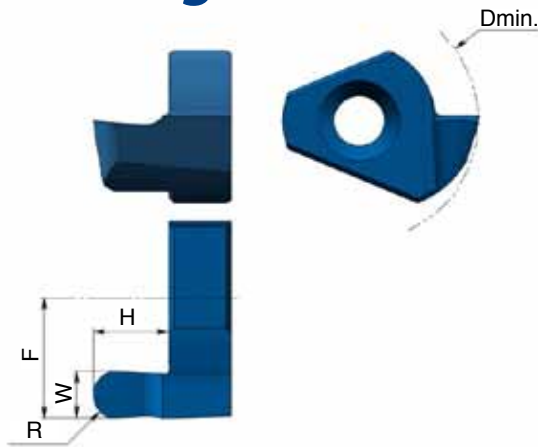

Insert Type	Ordering Code	W $\pm .001$	R	H max	D min	F
T10	T10 ZI R05 H15	.039	.020	.06	.55	.31
	T10 ZI R08 H25	.063	.031	.10		
	T10 ZI R10 H30	.079	.039	.12		
	T10 ZI R125 H30	.098	.049	.12		
	T10 ZI R15 H30	.118	.059	.12		

External

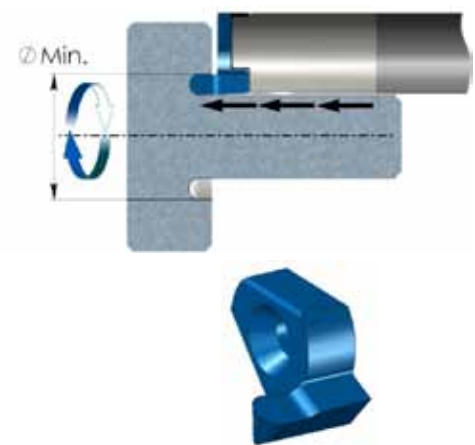
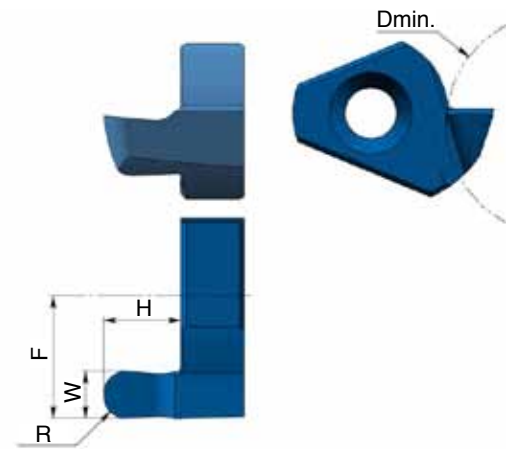

Insert Type	Ordering Code	W $\pm .001$	R	H max	D min	F
T10	T10 ZE R05 H15	.039	.020	.06	.47	.31
	T10 ZE R08 H25	.063	.031	.10		
	T10 ZE R10 H30	.079	.039	.12		
	T10 ZE R125 H30	.098	.049	.12		
	T10 ZE R15 H30	.118	.059	.12		

Carbide Shank Toolholder

With through coolant

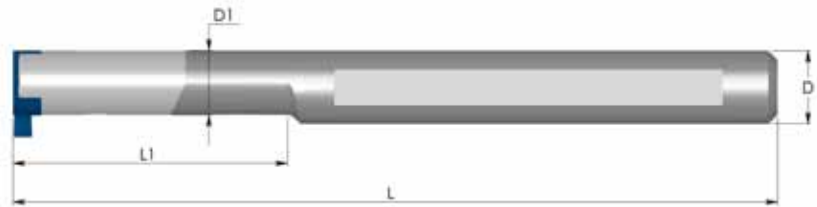

Insert Type	Ordering Code	D	D1	L1	L	Insert Screw	Torx Key
T8	ST 0312 L08 F08C	5/16	.28	.79	3.1	S5	K5
	ST 0312 L11 G08C	5/16	.28	1.18	3.7	S5	K5
	ST 0312 L15 H08C	5/16	.28	1.57	4.1	S5	K5

Metric Shank

Insert Type	Ordering Code	D mm	D1	L1	L	Insert Screw	Torx Key
T8	ST 0008 L20 F08C	8	.28	.79	3.1	S5	K5
	ST 0008 L30 G08C	8	.28	1.18	3.7	S5	K5
	ST 0008 L40 H08C	8	.28	1.57	4.1	S5	K5

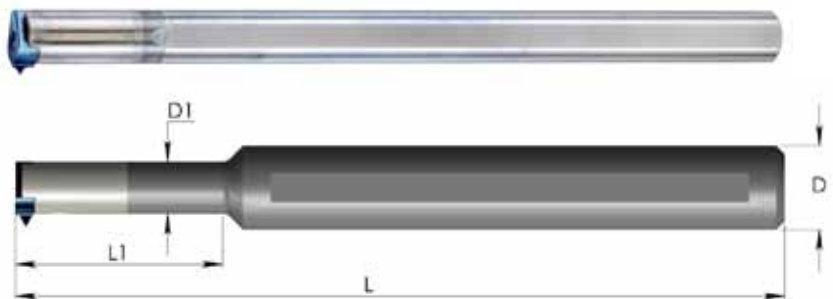

Insert Type	Ordering Code	D	D1	L1	L	Insert Screw	Torx Key
T10	ST 0375 M10C	3/8	.38	-	5.9	S11	K11
	ST 0500 L16 J10C	1/2	.40	1.6	4.3	S11	K11
	ST 0500 L22 K10C	1/2	.40	2.2	4.9	S11	K11

Metric Shank

Insert Type	Ordering Code	D mm	D1	L1	L	Insert Screw	Torx Key
T10	ST 0010 M10C	10	.40	-	5.9	S11	K11
	ST 0012 L40 J10C	12	.40	1.6	4.3	S11	K11
	ST 0012 L55 K10C	12	.40	2.2	4.9	S11	K11

Steel Toolholders

With through coolant

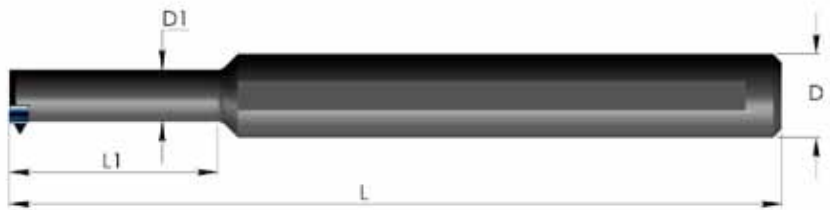

Insert Type	Ordering Code	D	D1	L1	L	Insert Screw	Torx Key
T10	ST 0500 L10 E10	1/2	.40	1.0	2.8	S11	K11
	ST 0625 L10 G10	5/8	.40	1.0	3.5	S11	K11
	ST 0625 L14 H10	5/8	.40	1.4	3.9	S11	K11

Metric Shank

Insert Type	Ordering Code	D mm	D1	L1	L	Insert Screw	Torx Key
T10	ST 0012 L25 E10	12	.40	1.0	2.8	S11	K11
	ST 0016 L25 G10	16	.40	1.0	3.5	S11	K11
	ST 0016 L35 H10	16	.40	1.4	3.9	S11	K11

Technical Section

Cutting Data

ISO	Materials	Cutting Speed ft/min	Recommended feed rate inch/rev
P	Low and Medium Carbon Steels <0.55%C	80-230	Grooving: .0004 - .001 Back turning: .001 - .004 Face grooving: .0004 - .003 Chamfering: .001 - .003
	High Carbon Steels ≥0.55%C	65-165	
	Alloy Steels, Treated Steels	50-100	
M	Stainless Steels - Free Cutting	80-230	
	Stainless Steels - Austenitic	65-130	
	Cast Steels	100-230	
K	Cast Iron	50-100	
N	Aluminum ≤12%Si, Copper	100-300	
	Aluminum >12% Si	65-230	
	Synthetics, Duroplastics, Thermoplastics	65-230	
S	Nickel Alloys, Titanium Alloys	65-165	
H	Hardened Steel 45 - 50HRc	30-130	

Threading Passes

Pitch:	mm	0.5	0.7	0.8	1.0	1.25	1.5	2-5
	TPI	48	36	32	24	20	16	14-5
Number of Passes		6-12	7-14	7-16	8-18	8-20	10-22	20-38

Swiss-Line



Contents:	Page:	Contents:	Page:
Polygon Swiss Line	130	Threading - Partial Profile 60°	144
Product Identification	131	Threading - Partial Profile 55°	144
Grooving	132	External Toolholders - G6	145-146
Grooving and Profiling (full radius)	132	Cutting Data	146
Parting Off	133	Swiss-Line	147-162
Back Turning	134	Product Identification - Inserts	148
Front Turning	134	Grooving	149
Threading - Partial Profile 60°	135	Grooving and Profiling (full radius)	150
Threading - Partial Profile 55°	135	Parting Off	151-152
External Toolholders - Polygon	136	Back Turning	153
Working method	137	Front Turning	153
Cutting Data	138	Threading - Partial Profile 60°	154
6 Cutting Edges Turning Insert - G6	139-146	Threading - Partial Profile 55°	154
Product Identification	140	Threading - ISO metric 60°	155
Grooving	141	Threading - UN unified 60°	156
Grooving and Profiling (full radius)	141	External Toolholders	157-158
Parting Off	142	Swiss Line Slim Holders	159
Back Turning	143	Working Method	160
Front Turning	143	Carbide Grades - Cutting Data	161

Polygon Swiss Line

Carmex extends the Swiss Line range by offering a new type of polygon inserts and tool holders for external turning, grooving, parting and threading on Swiss-Type machines. Dedicated especially for small parts machining.



Features

- High precision ground inserts.
- All inserts can be used with same tool holders.
- A combination of the latest carbide and coating technologies guarantees maximum tool life and improved productivity.
- For a wide range of materials.
- Coated holders provides abrasive resistance.

Carbide grade: BLU, K20

Product Identification Polygon Inserts

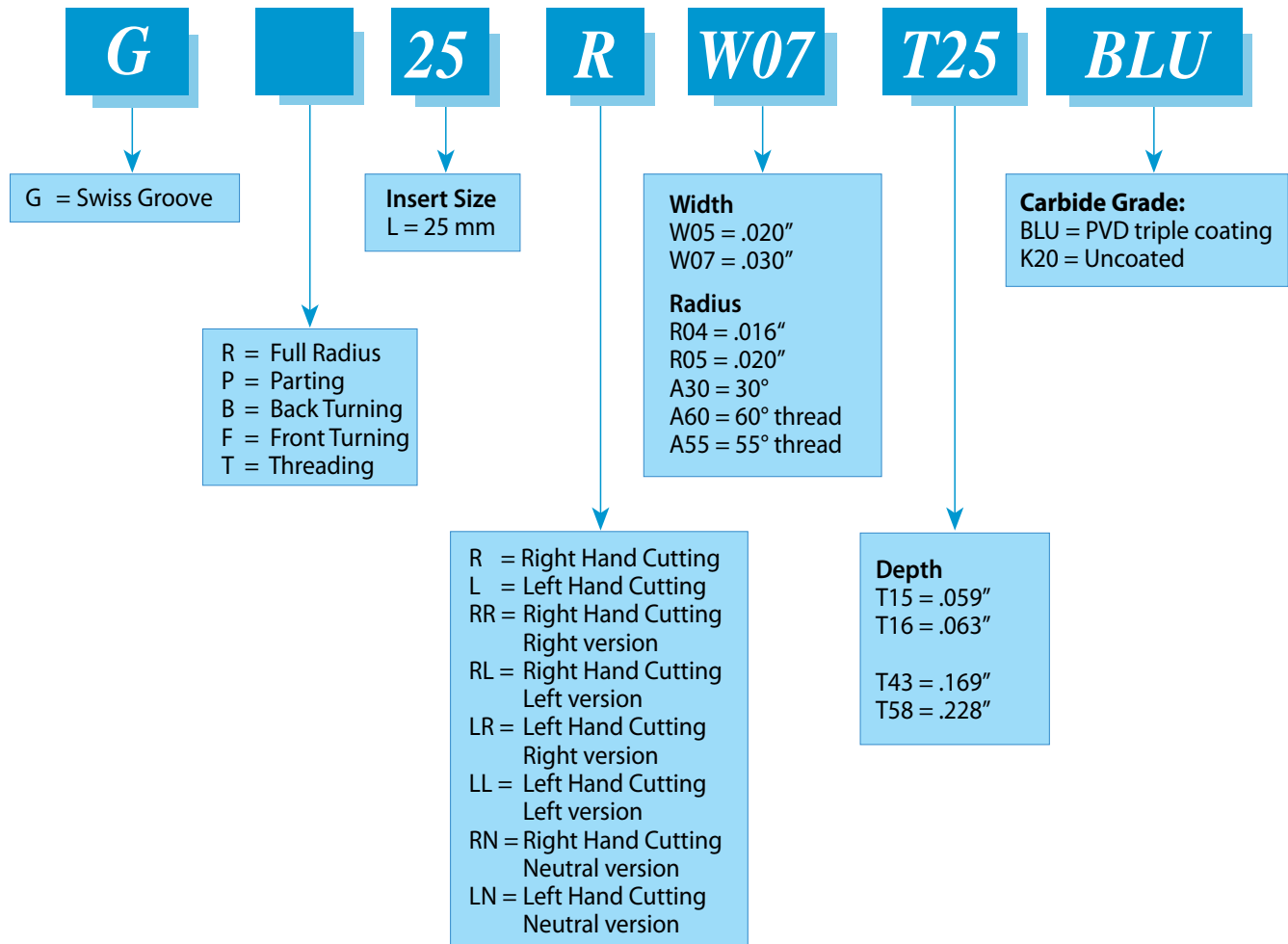

Grooving

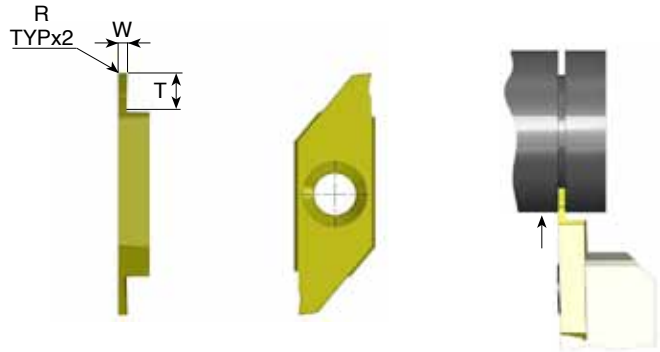

Right hand cutting

Ordering Code	W ±.001	T max	R	Feed Inch/rev
G25 R W05 T15	.020	.059	0	.0004-.002
G25 R W07 T25	.030	.098	0	.0008-.003
G25 R W10 T27	.039	.106	.002	.0008-.004
G25 R W12 T30	.047	.118	.002	.0008-.004
G25 R W15 T38	.059	.150	.002	.0008-.005
G25 R W20 T38	.079	.150	.002	.0008-.005
G25 R W25 T38	.098	.150	.002	.0008-.006

	K20	BLU
P		●
M	●	●
K	●	○
N	●	
S	●	●
H		≤45 HRc

* For L.H, specify G25 L instead of G25 R

Grooving and Profiling (full radius)

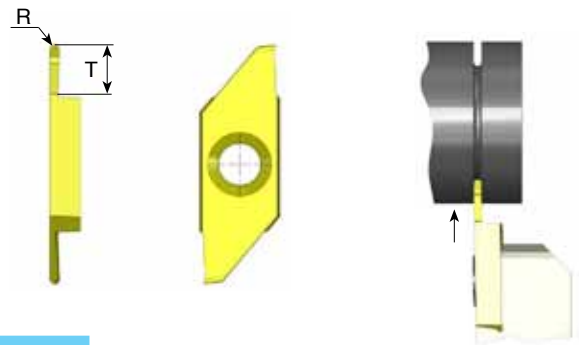

Right hand cutting

Ordering Code	R±.001	T max	Feed Inch/rev
GR25 R R02 T15	.010	.059	.0004-.002
GR25 R R04 T25	.016	.098	.0004-.003
GR25 R R05 T27	.020	.106	.0004-.004

* For L.H, specify GR25 L instead of GR25 R

● First choice ○ Alternative

Parting Off

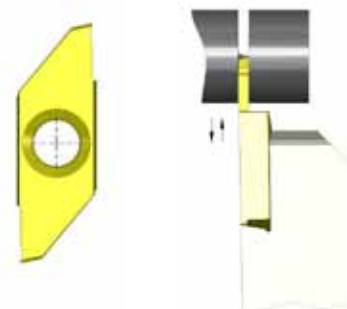
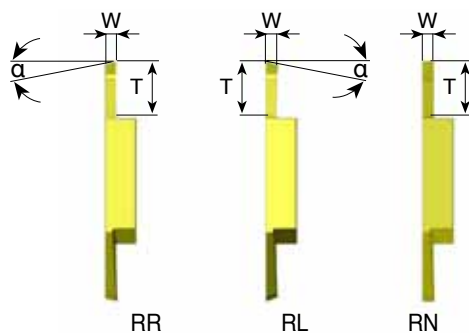

Right hand cutting

Ordering Code	W	α°	T max	Feed Inch/rev
GP25 RR W07 T43	.028	15	.169	.0008-.003
GP25 RL W07 T43	.028	15	.169	.0008-.003
GP25 RN W07 T43	.028	0	.169	.0008-.003
GP25 RR W10 T58	.039	15	.228	.0008-.005
GP25 RL W10 T58	.039	15	.228	.0008-.005
GP25 RN W10 T58	.039	0	.228	.0008-.005
GP25 RR W15 T58	.059	15	.228	.0008-.005
GP25 RL W15 T58	.059	15	.228	.0008-.005
GP25 RN W15 T58	.059	0	.228	.0008-.005
GP25 RR W20 T58	.079	15	.228	.0008-.005
GP25 RL W20 T58	.079	15	.228	.0008-.005
GP25 RN W20 T58	.079	0	.228	.0008-.005
GP25 RR W25 T58	.098	15	.228	.002-.005
GP25 RL W25 T58	.098	15	.228	.002-.005
GP25 RN W25 T58	.098	0	.228	.002-.005

	K20	BLU
P		●
M	●	●
K	●	○
N	●	
S	●	●
H		≤45 HRc

* For L.H, specify GP25 LR instead of GP25 RR
 GP25 LL instead of GR25 RL
 GP25 LN instead of GR25 RN

● First choice ○ Alternative

Back Turning

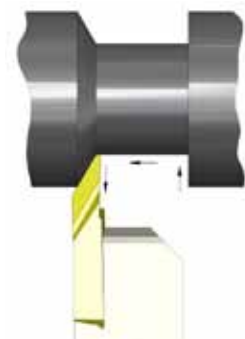
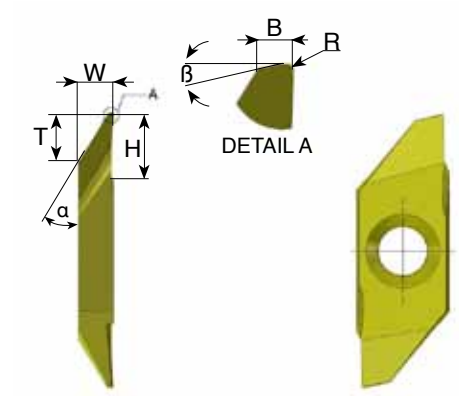

Right hand cutting

Ordering Code	α°	β°	R	W	T _{max}	B	H	Feed Inch/rev
GB25 R A30 R03	30	15	.001	.118	.157	.020	.315	.002-.005
GB25 R A30 R10	30	15	.004	.118	.157	.020	.315	.002-.005

* For L.H, specify GB25 L instead of GB25 R

	K20	BLU
P		●
M	●	●
K	●	○
N	●	
S	●	●
H		≤45 HRc

Front Turning

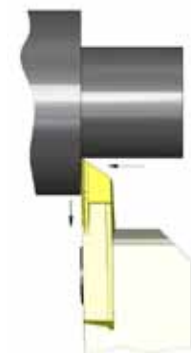
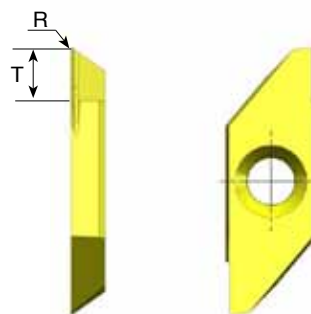

Right hand cutting

Ordering Code	T _{max}	R	Feed Inch/rev
GF25 R T40	.157	.002	.002-.005

* For L.H, specify GF25 L instead of GF25 R

- First choice
- Alternative

Threading - Partial Profile 60°

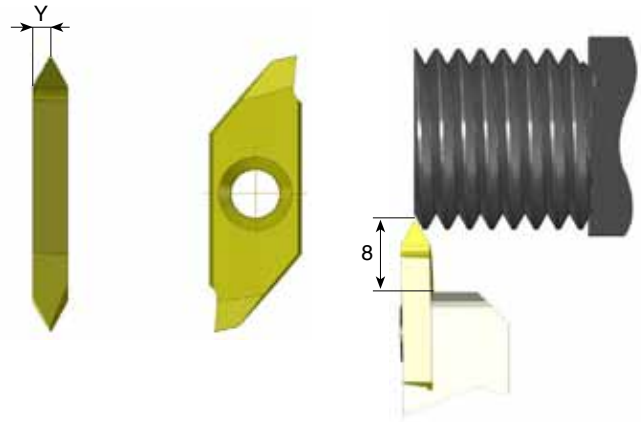

Right hand cutting

Ordering Code	Pitch Range		Y
	mm	TPI	
GT25 R A60	0.25-0.8	100-32	.028
GT25 R G60	1.0-3.0	24-8	.063

* For L.H, specify GT25 L instead of GT25 R

	K20	BLU
P		●
M	●	●
K	●	○
N	●	
S	●	●
H		≤45 HRc

Threading - Partial Profile 55°

Right hand cutting

Ordering Code	Pitch Range		Y
	mm	TPI	
GT25 R A55	0.5-1.5	48-16	.039
GT25 R G55	1.75-3.0	14-8	.063

* For L.H, specify GT25 L instead of GT25 R

● First choice ○ Alternative

External Toolholders - Polygon

Product Identification

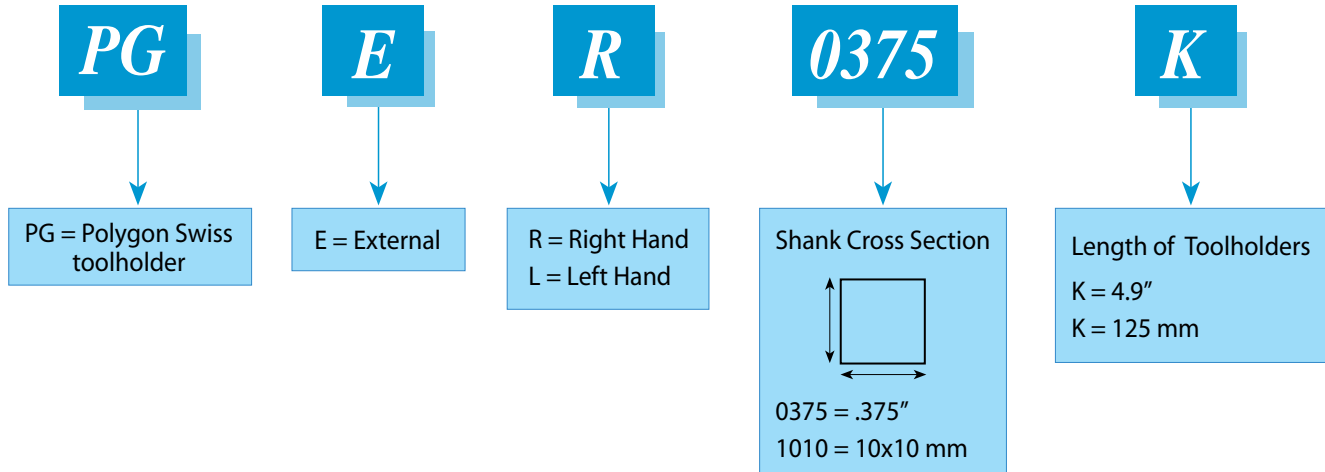

Right hand - Inch Holders

Ordering Code	B	H	L1	L	F	F1	Insert Screw Torx +	Key Torx +
PGER 0375 K	.375	.375	.31	4.9	.38	.38	S26P	K11P
PGER 0500 K	.500	.500	.31	4.9	.50	.50	S26P	K11P
PGER 0625 K	.625	.625	.31	4.9	.63	.63	S26P	K11P

Right hand - Metric Holders

Ordering Code	B	H	L1	L	F	F1	Insert Screw Torx +	Key Torx +
PGER 1010 K	10	10	8	125	10	10	S26P	K11P
PGER 1212 K	12	12	8	125	12	12	S26P	K11P
PGER 1616 K	16	16	8	125	16	16	S26P	K11P

* For L.H, specify **PGEL** instead of **PGER**
Coated holders provides high abrasive resistance

Working method

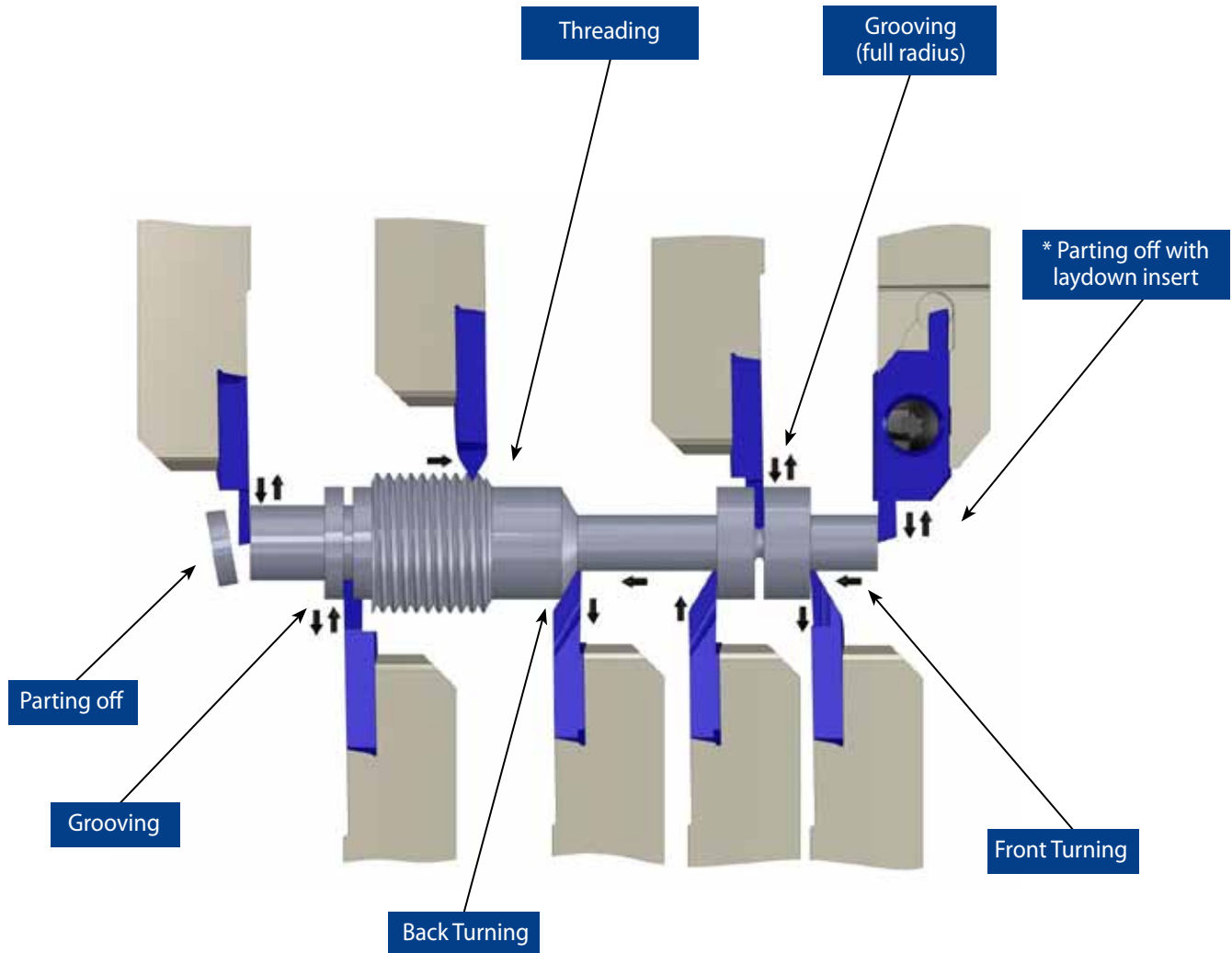

* Available upon request (grooving, parting, threading).

Cutting Data

Polygon Swiss Line

Carbide grades:

BLU PVD triple layer coated Sub-Micron grade for Steel, Stainless Steels, Titanium and hard materials.

K20 Uncoated Sub-Micron carbide grade for Aluminum and non-ferrous materials, Stainless Steels and Titanium.

ISO Standard	Material	Cutting Speed ft/min	
		K20	BLU
P	Low and Medium Carbon Steels <0.55%C	-	260-490
	High Carbon Steels ≥0.55%C	-	230-395
	Alloy Steels, Treated Steels	-	130-260
M	Stainless Steel-Free Cutting	100-260	200-395
	Stainless Steel-Austenitic	65-230	100-295
	Cast Steels	100-260	165-395
K	Cast Iron	165-395	200-490
N	Aluminum ≤12%Si, Copper	395-820	-
	Aluminum >12%Si	295-656	-
	Synthetics, Duroplastics, Thermoplastics	230-490	-
S	Nickel Alloys, Titanium Alloys.	65-165	100-230
H	Hardened Steel, ≤45 HRc	-	65-165

6 Cutting Edges Turning Insert - G6

Grooving, parting-off and threading

Benefits

- High productivity and cost efficiency due to six cutting edges.
- One holder for all insert types - Maximum versatility.
- High precision thanks to the fully ground profile.

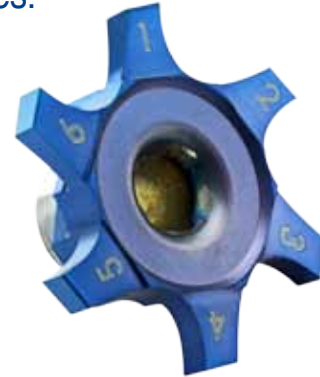

Features

- Strong and stable clamping due to the unique insert shape.
- Can be used with high machining parameters, and provides high surface finish.
- Internal coolant provides the coolant liquid towards the cutting edge.

Application

- Multi-function inserts for grooving, parting, turning and threading.
- Fit to a large range of diameters from very small applications with a thin wall up to 60 mm diameter.

Carbide grade: BLU, K20.

Product Identification

G6 Inserts

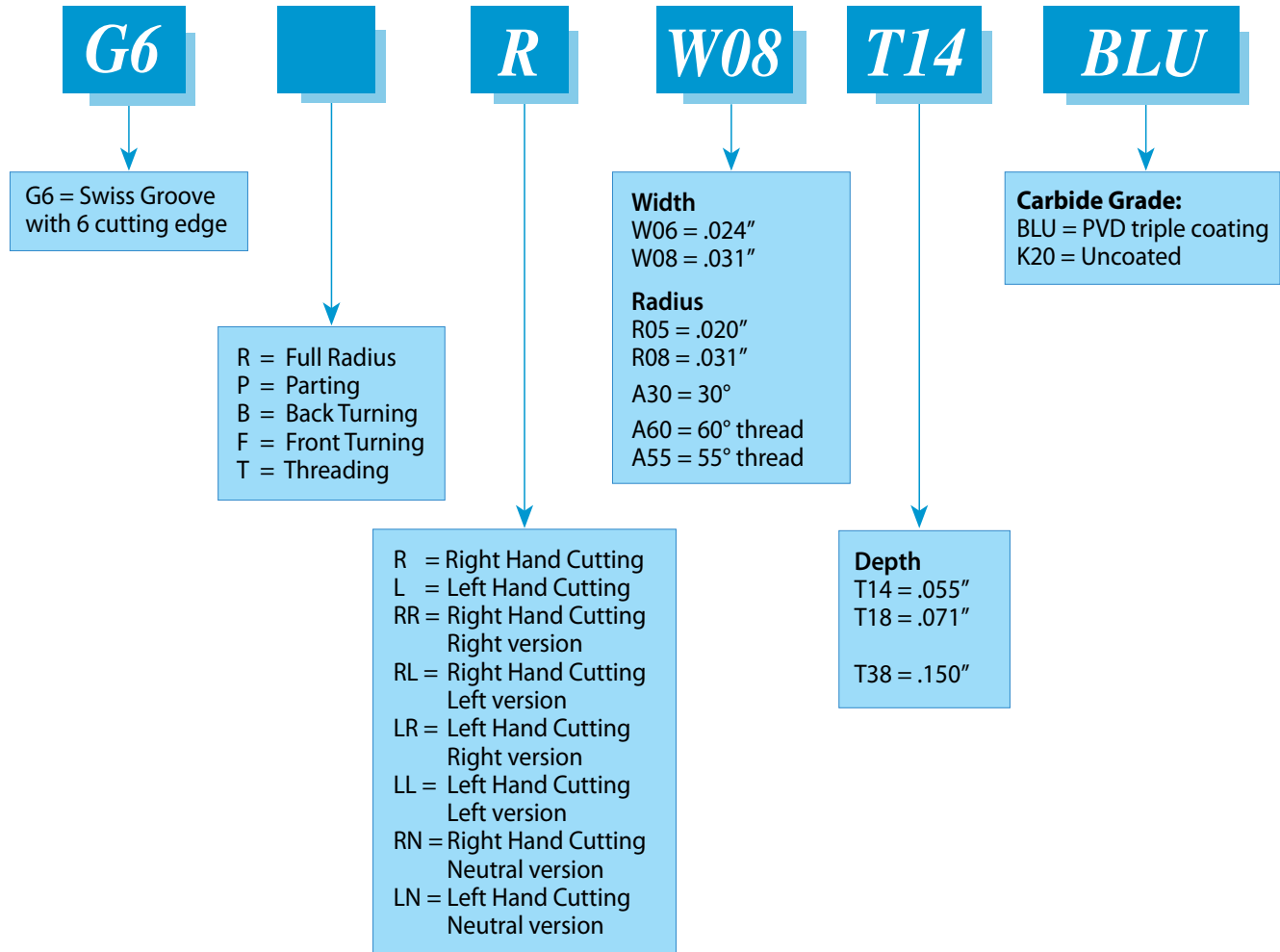

Grooving

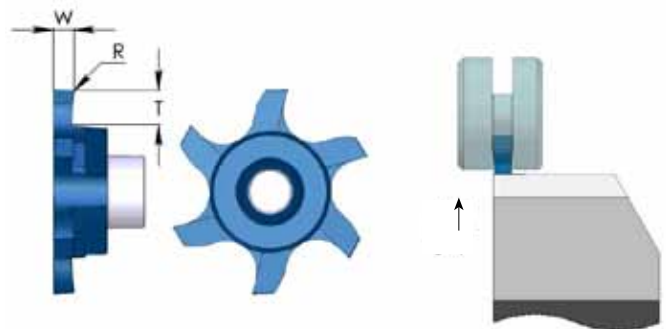

Right hand cutting

Ordering Code	W ±.001	T max	R	Feed Inch/rev
G6 R W06 T11	.024	.043	0	.0004-.002
G6 R W08 T14	.031	.055	0	.0008-.003
G6 R W10 T18	.039	.071	.002	.0008-.004
G6 R W15 T33	.059	.130	.002	.0008-.005
G6 R W20 T38	.079	.150	.004	.0008-.005
G6 R W25 T38	.098	.150	.004	.0008-.006

	K20	BLU
P		●
M	●	●
K	●	○
N	●	
S	●	●
H		≤45 HRc

* For L.H, specify G6 L instead of G6 R

Grooving and Profiling (full radius)

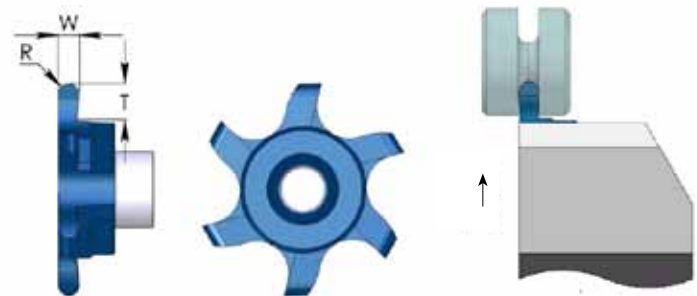

Right hand cutting

Ordering Code	R±.001	W	T max	Feed Inch/rev
G6R R R05 T25	.020	.039	.098	.0008-.004
G6R R R08 T30	.031	.063	.118	.0008-.004
G6R R R10 T38	.039	.079	.150	.0008-.005
G6R R R12 T38	.049	.098	.150	.0008-.006

* For L.H, specify G6R L instead of G6R R

● First choice ○ Alternative

Parting Off

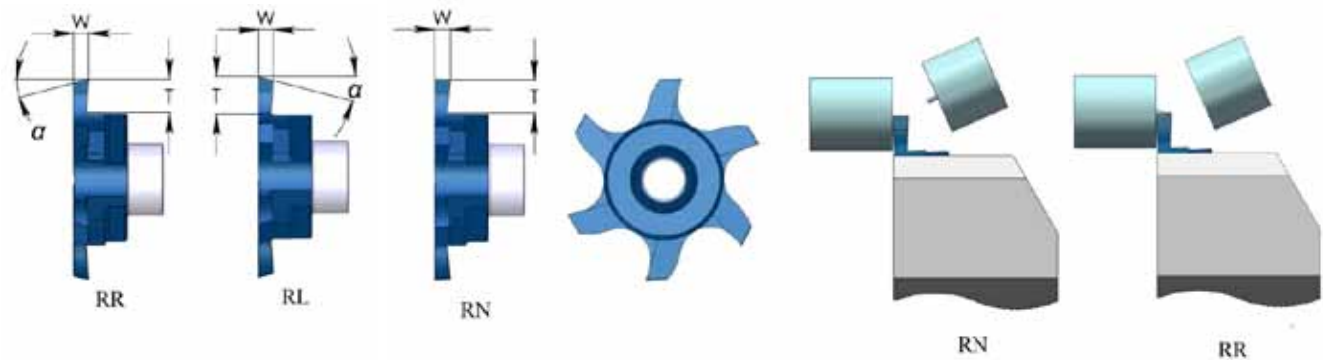

Right hand cutting

Ordering Code	W	α°	T max	Feed Inch/rev
G6P RR W10 T38	.039	15	.150	.0008-.004
G6P RL W10 T38	.039	15	.150	.0008-.004
G6P RN W10 T38	.039	0	.150	.0008-.004
G6P RR W15 T38	.059	15	.150	.0008-.005
G6P RL W15 T38	.059	15	.150	.0008-.005
G6P RN W15 T38	.059	0	.150	.0008-.005
G6P RR W20 T38	.079	15	.150	.0008-.005
G6P RL W20 T38	.079	15	.150	.0008-.005
G6P RN W20 T38	.079	0	.150	.0008-.005

	K20	BLU
P		●
M	●	●
K	●	○
N	●	
S	●	●
H		≤45 HRc

* For L.H, specify G6P LR instead of G6P RR
 G6P LL instead of G6P RL
 G6P LN instead of G6P RN

● First choice ○ Alternative

Back Turning

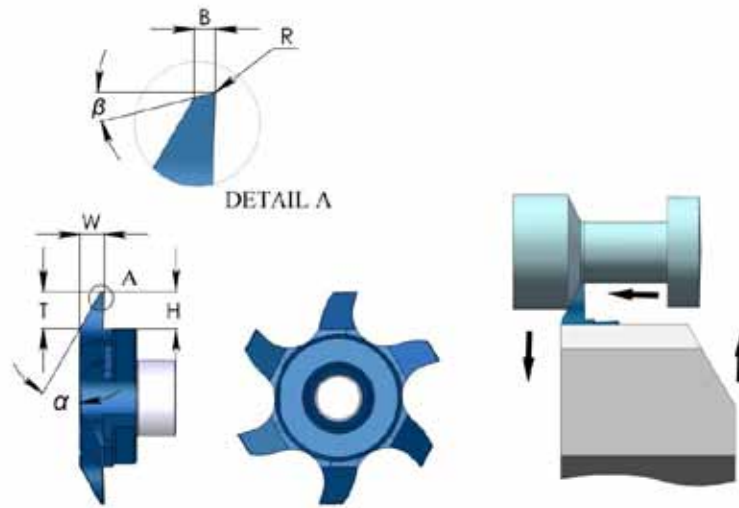

Right hand cutting

Ordering Code	α°	β°	R	W	T _{max}	B	H	Feed Inch/rev
G6B R A30	30	12	.004	.106	.150	.02	.150	.002-.005

* For L.H, specify G6B L instead of G6B R

	K20	BLU
P		●
M	●	●
K	●	○
N	●	
S	●	●
H		≤45 HRc

Front Turning

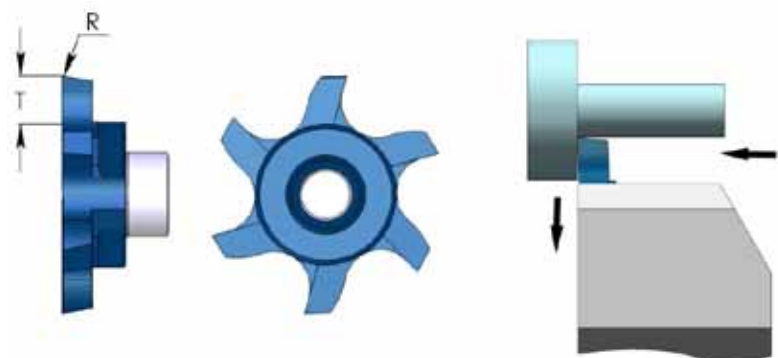

Right hand cutting

Ordering Code	T _{max}	R	Feed Inch/rev
G6F R T38	.150	.004	.002-.005

* For L.H, specify G6F L instead of G6F R

- First choice
- Alternative

Threading - Partial Profile 60°

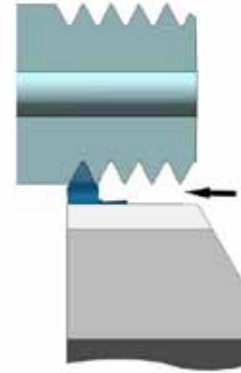
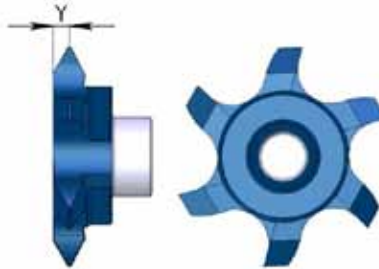

Right hand cutting

Ordering Code	Pitch Range		Y
	mm	TPI	
G6T R A60	0.5-1.5	48-16	.031
G6T R G60	1.75-3.0	14-8	.059
G6T R AG60	0.5-3.0	48-8	.059

* For L.H, specify G6T L instead of G6T R

	K20	BLU
P		●
M	●	●
K	●	○
N	●	
S	●	●
H		≤45 HRc

Threading - Partial Profile 55°

Right hand cutting

Ordering Code	Pitch Range		Y
	mm	TPI	
G6T R A55	0.5-1.5	48-16	.031
G6T R G55	1.75-3.0	14-8	.059
G6T R AG55	0.5-3.0	48-8	.059

* For L.H, specify G6T L instead of G6T R

● First choice ○ Alternative

External Toolholders - G6

Coolant through toolholders, for external turning in Swiss type lathes machines. The high pressure coolant is directed towards the insert cutting edge in order to evacuate the chips created and avoid build up edge. Including a coolant connector for fast attachment on the machine.

Product Identification

G6

G6 = Swiss toolholder

E

E = External

R

R = Right Hand
L = Left Hand

0500

Shank Cross Section

0500 = .500"
1212 = 12x12 mm

K

Length of Toolholders

K = 4.9"
M = 5.9"
K = 125 mm
M = 150 mm

Right hand – Inch Holders

Ordering Code	B	H	L1	L	H1	F	B1	Insert Screw Torx +	Torx + Key	**Coolant connector (mm)
*G6ER 0500 K	.500	.500	.8	4.9	.9	.500	.63	S16LP	K16P	Ø4 / Ø6
G6ER 0625 K	.625	.625	.8	4.9	1.1	.625	.63	S16LP	K16P	Ø4 / Ø6
G6ER 0750 K	.750	.750	.8	4.9	1.2	.750	.75	S16LP	K16P	Ø4 / Ø6
G6ER 1000 M	1.000	1.000	.8	5.9	1.4	1.000	1.000	S16LP	K16P	Ø4 / Ø6

* Without internal coolant

** Coolant pipe diameter

For L.H, specify G6EL instead of G6ER

Coated holders provides high abrasive resistance

Right hand – Metric Holders

Ordering Code	B	H	L1	L	H1	F	B1	Insert Screw Torx +	Torx + Key	**Coolant connector (mm)
* G6ER 1212 K	12	12	20	125	23	12	16	S16LP	K16P	Ø4 / Ø6
G6ER 1616 K	16	16	20	125	27	16	16	S16LP	K16P	Ø4 / Ø6
G6ER 2020 K	20	20	20	125	31	20	20	S16LP	K16P	Ø4 / Ø6
G6ER 2525 M	25	25	20	150	36	25	25	S16LP	K16P	Ø4 / Ø6

* Without internal coolant

** Coolant pipe diameter

For L.H, specify G6EL instead of G6ER

Coated holders provides high abrasive resistance

Cutting Data

G6 Inserts

Carbide grades:

BLU PVD triple layer coated Sub-Micron grade for Steel, Stainless Steels, Titanium and hard materials.

K20 Uncoated Sub-Micron carbide grade for Aluminum and non-ferrous materials, Stainless Steels and Titanium.

ISO Standard	Material	Cutting Speed ft/min	
		K20	BLU
P	Low and Medium Carbon Steels <0.55%C	-	260-490
	High Carbon Steels ≥0.55%C	-	230-395
	Alloy Steels, Treated Steels	-	130-260
M	Stainless Steel-Free Cutting	100-260	200-395
	Stainless Steel-Austenitic	65-230	100-295
	Cast Steels	100-260	165-395
K	Cast Iron	165-395	200-490
N	Aluminum ≤12%Si, Copper	395-820	-
	Aluminum >12%Si	295-656	-
	Synthetics, Duroplastics, Thermoplastics	230-490	-
S	Nickel Alloys, Titanium Alloys.	65-165	100-230
H	Hardened Steel, ≤45 HRc	-	65-165

Swiss-Line

- Swiss style lathes are becoming a popular alternative to large lathes and machining centers in many companies.
- Carmex is introducing a new line of inserts and toolholders, developed for automatic and Swiss style lathes.
- Designed for economic production of parting, grooving, profiling and chamfering.

Advantages

Advanced sub-micron grade (K10-K30) - a combination of strength, toughness, wear resistance and edge sharpness.

- Grounded cutting edges.
- Advanced and unique PVD triple coating, for high wear and heat resistance.
- For most types of material, including Stainless Steels, Titanium and Super Alloys.

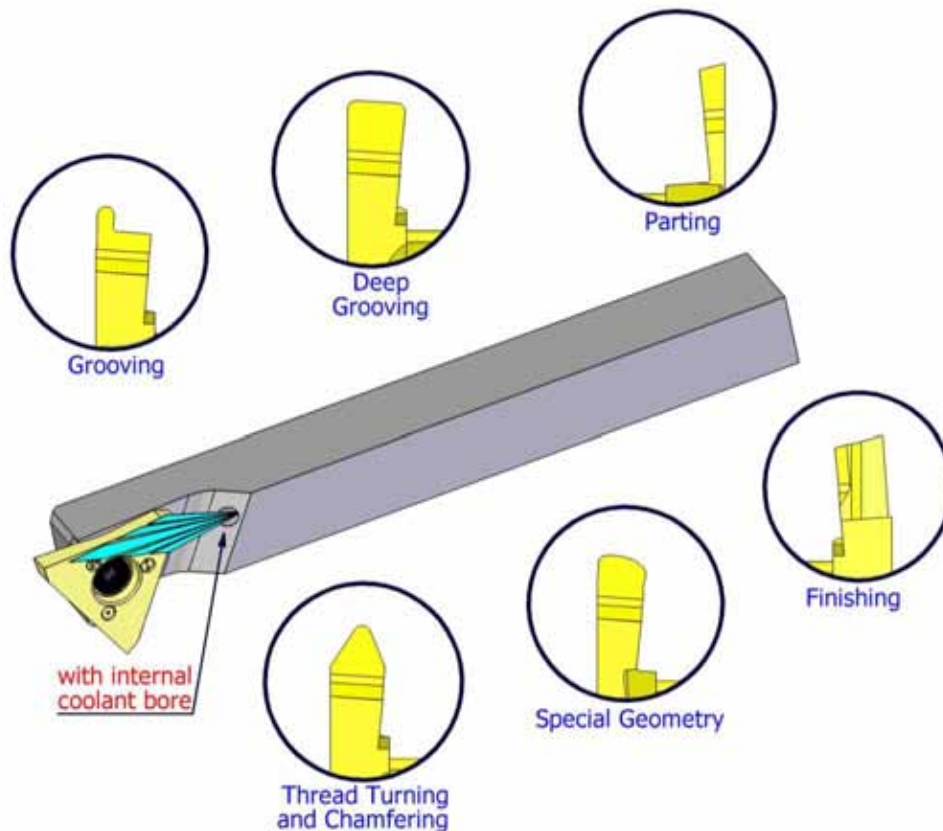

- Three cutting edges.
- The insert can be indexed directly on the machine.
- Internal coolant to the cutting edge.

Product Identification

Inserts

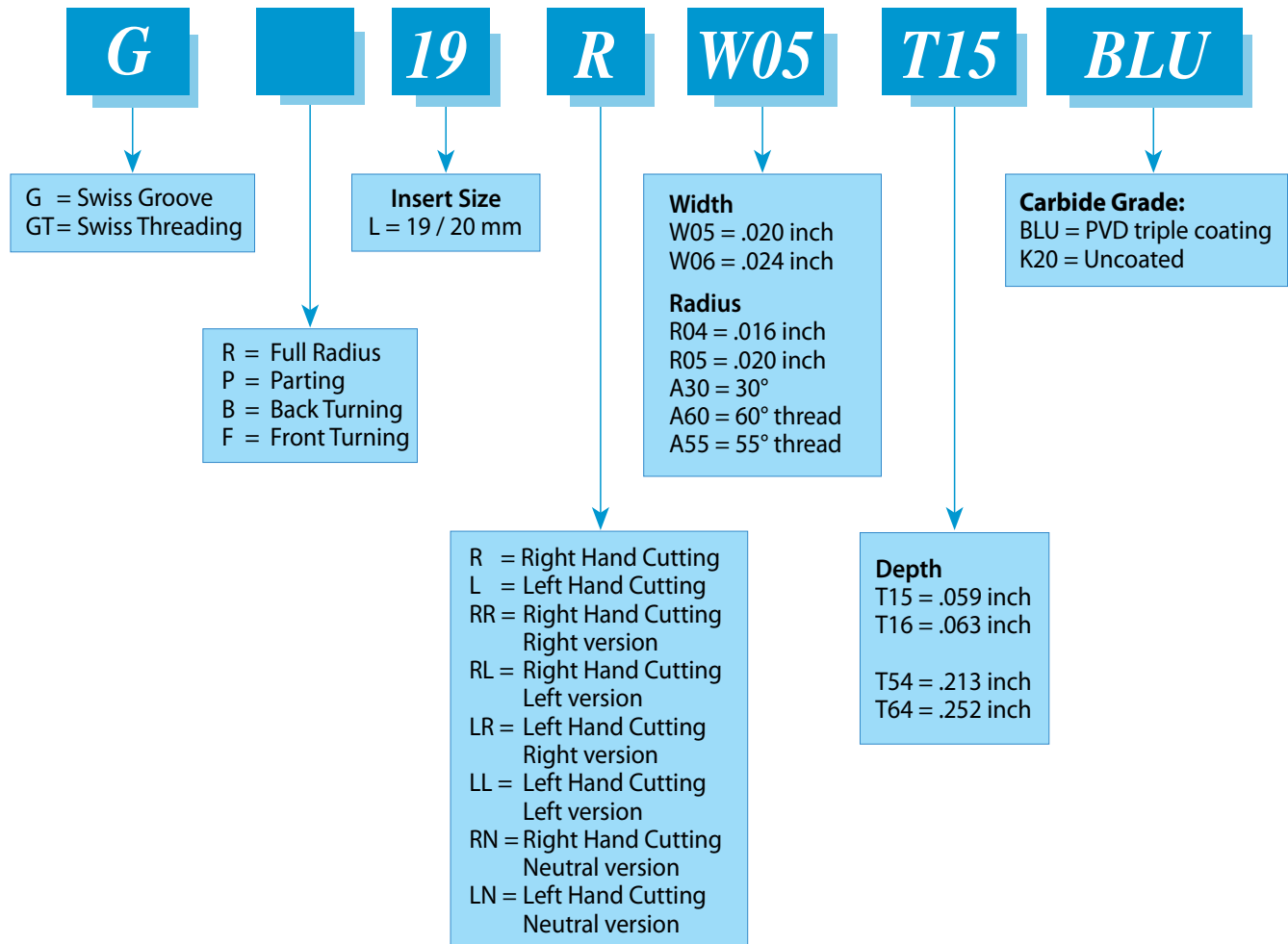

Grooving

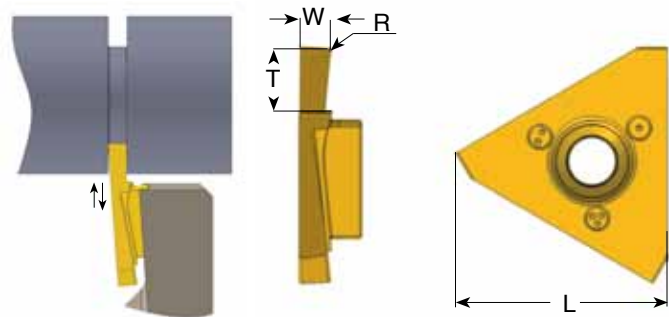

Right hand cutting

L	Ordering Code	W ±.001	T max	R	Feed Inch/rev	
					Radial	Axial
19	G19 R W05 T15	.020	.059	0	.0004-.0024	.001-.004
	G19 R W06 T16	.024	.063	0	.0004-.0024	.001-.004
	G19 R W07 T17	.030	.067	0	.0004-.0024	.001-.004
	G19 R W08 T18	.031	.079	.002	.0004-.0024	.001-.004
	G19 R W10 T22	.040	.098	.002	.001-.003	.001-.004
	G19 R W12 T24	.047	.118	.002	.001-.003	.001-.004
	G19 R W14 T28	.055	.118	.002	.001-.003	.001-.004
	G19 R W15 T30	.059	.118	.002	.001-.003	.001-.004
20	G19 R W17 T34	.067	.157	.002	.0016-.0035	.001-.008
	G20 R W20 T40	.079	.157	.004	.002-.004	.001-.008
	G20 R W22 T45	.089	.197	.004	.002-.004	.001-.008
	G20 R W25 T50	.098	.236	.004	.002-.004	.001-.008
	G20 R W30 T60	.118	.236	.004	.002-.004	.001-.008

Left hand cutting

L	Ordering Code	W ±.001	T max	R	Feed Inch/rev	
					Radial	Axial
19	G19 L W05 T15	.020	.059	0	.0004-.0024	.001-.004
	G19 L W06 T16	.024	.063	0	.0004-.0024	.001-.004
	G19 L W07 T17	.030	.067	0	.0004-.0024	.001-.004
	G19 L W08 T18	.031	.079	.002	.0004-.0024	.001-.004
	G19 L W10 T22	.040	.098	.002	.001-.003	.001-.004
	G19 L W12 T24	.047	.118	.002	.001-.003	.001-.004
	G19 L W14 T28	.055	.118	.002	.001-.003	.001-.004
	G19 L W15 T30	.059	.118	.002	.001-.003	.001-.004
20	G19 L W17 T34	.067	.157	.002	.0016-.0035	.001-.008
	G20 L W20 T40	.079	.157	.004	.002-.004	.001-.008
	G20 L W22 T45	.089	.197	.004	.002-.004	.001-.008
	G20 L W25 T50	.098	.236	.004	.002-.004	.001-.008
	G20 L W30 T60	.118	.236	.004	.002-.004	.001-.008

Grooving and Profiling (full radius)

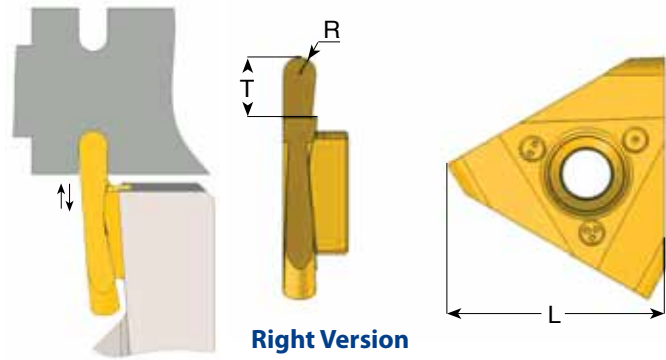

Right hand cutting

L	Ordering Code	R ±.0012	T max	Feed Inch/rev	
				Radial	Axial
19	GR19 R R02 T15	.010	.059	.0004-.003	.001-.004
	GR19 R R04 T18	.016	.079	.0004-.003	.001-.004
	GR19 R R05 T22	.020	.098	.001-.003	.001-.004
	GR19 R R06 T26	.024	.118	.001-.003	.001-.004
	GR19 R R08 T33	.031	.138	.0016-.0035	.001-.008
	GR19 R R10 T40	.040	.158	.002-.004	.001-.008
20	GR20 R R12 T50	.050	.236	.002-.004	.001-.008
	GR20 R R15 T60	.059	.236	.002-.004	.001-.008

Left hand cutting

L	Ordering Code	R ±.0012	T max	Feed Inch/rev	
				Radial	Axial
19	GR19 L R02 T15	.010	.059	.0004-.003	.001-.004
	GR19 L R04 T18	.016	.079	.0004-.003	.001-.004
	GR19 L R05 T22	.020	.098	.001-.003	.001-.004
	GR19 L R06 T26	.024	.118	.001-.003	.001-.004
	GR19 L R08 T33	.031	.138	.0016-.0035	.001-.008
	GR19 L R10 T40	.040	.158	.002-.004	.001-.008
20	GR20 L R12 T50	.050	.236	.002-.004	.001-.008
	GR20 L R15 T60	.059	.236	.002-.004	.001-.008

Parting Off

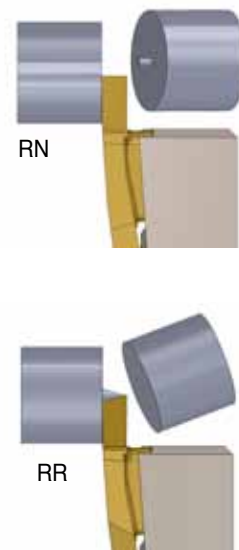
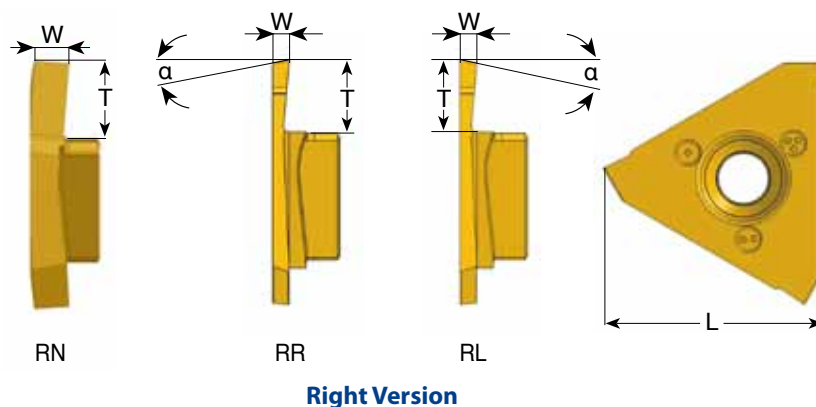

Right hand cutting

L	Ordering Code	W	α°	T max	Feed Inch/rev Radial
19	GP19 RR W10 T54	.039	15	.213	.001-.0035
	GP19 RL W10 T54	.039	15	.213	.001-.0035
	GP19 RN W10 T54	.039	0	.213	.001-.0035
	GP19 RR W12 T54	.047	15	.213	.001-.0035
	GP19 RL W12 T54	.047	15	.213	.001-.0035
	GP19 RN W12 T54	.047	0	.213	.001-.0035
20	GP20 RR W15 T64	.059	15	.252	.0016-.004
	GP20 RL W15 T64	.059	15	.252	.0016-.004
	GP20 RN W15 T64	.059	0	.252	.0016-.004
	GP20 RR W18 T64	.071	15	.252	.0016-.004
	GP20 RL W18 T64	.071	15	.252	.0016-.004
	GP20 RN W18 T64	.071	0	.252	.0016-.004
	GP20 RR W20 T64	.079	15	.252	.002-.0047
	GP20 RL W20 T64	.079	15	.252	.002-.0047
	GP20 RN W20 T64	.079	0	.252	.002-.0047
	GP20 RR W25 T64	.098	15	.252	.002-.0047
	GP20 RL W25 T64	.098	15	.252	.002-.0047
	GP20 RN W25 T64	.098	0	.252	.002-.0047
	GP20 RR W30 T64	.118	15	.252	.002-.0047
	GP20 RL W30 T64	.118	15	.252	.002-.0047
GP20 RN W30 T64	.118	0	.252	.002-.0047	

Parting Off

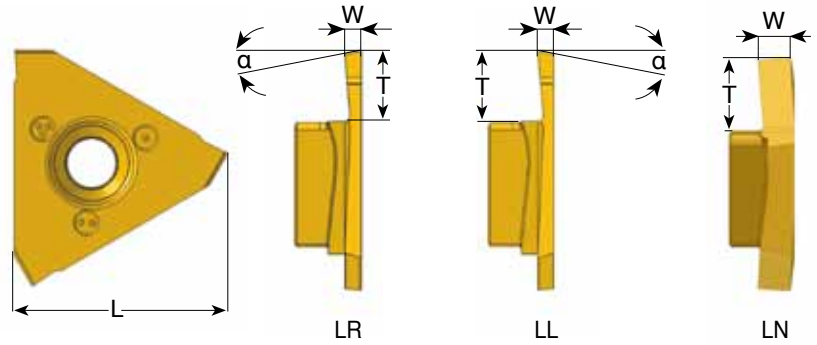

Left Version

Left hand cutting

L	Ordering Code	W	α°	T max	Feed Inch/rev Radial
19	GP19 LR W10 T54	.039	15	.213	.001-.0035
	GP19 LL W10 T54	.039	15	.213	.001-.0035
	GP19 LN W10 T54	.039	0	.213	.001-.0035
	GP19 LR W12 T54	.047	15	.213	.001-.0035
	GP19 LL W12 T54	.047	15	.213	.001-.0035
	GP19 LN W12 T54	.047	0	.213	.001-.0035
20	GP20 LR W15 T64	.059	15	.252	.0016-.004
	GP20 LL W15 T64	.059	15	.252	.0016-.004
	GP20 LN W15 T64	.059	0	.252	.0016-.004
	GP20 LR W18 T64	.071	15	.252	.0016-.004
	GP20 LL W18 T64	.071	15	.252	.0016-.004
	GP20 LN W18 T64	.071	0	.252	.0016-.004
	GP20 LR W20 T64	.079	15	.252	.002-.0047
	GP20 LL W20 T64	.079	15	.252	.002-.0047
	GP20 LN W20 T64	.079	0	.252	.002-.0047
	GP20 LR W25 T64	.098	15	.252	.002-.0047
	GP20 LL W25 T64	.098	15	.252	.002-.0047
	GP20 LN W25 T64	.098	0	.252	.002-.0047
	GP20 LR W30 T64	.118	15	.252	.002-.0047
	GP20 LL W30 T64	.118	15	.252	.002-.0047
GP20 LN W30 T64	.118	0	.252	.002-.0047	

Back Turning

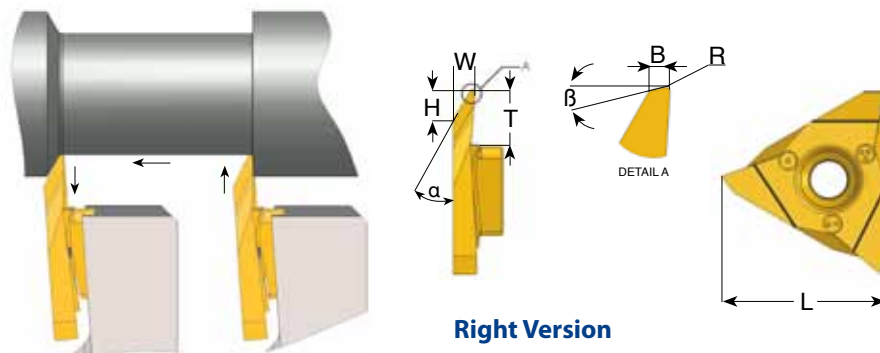

Right hand cutting

L	Ordering Code	α°	β°	R	W	H	B	T	Feed Inch/rev
19	GB19 R A30	30	12	.004	.134	.169	.02	.213	.002-.006
20	GB20 R A30	30	12	.004	.134	.169	.02	.252	.002-.006

Left hand cutting

L	Ordering Code	α°	β°	R	W	H	B	T	Feed Inch/rev
19	GB19 L A30	30	12	.004	.134	.169	.02	.213	.002-.006
20	GB20 L A30	30	12	.004	.134	.169	.02	.252	.002-.006

Front Turning

Right hand cutting

L	Ordering Code	T	Feed Inch/rev
19	GF19 R T54	.213	.002-.006
20	GF20 R T64	.252	.002-.006

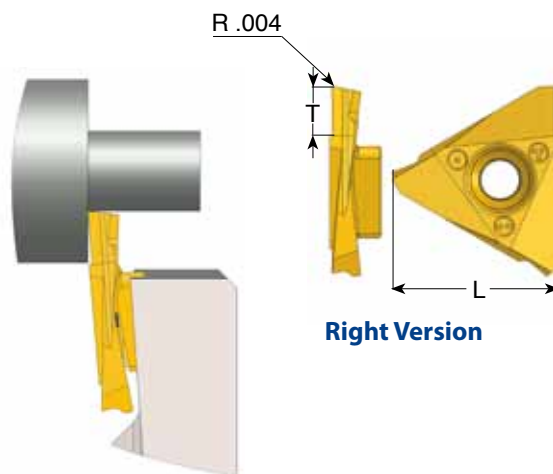

Left hand cutting

L	Ordering Code	T	Feed Inch/rev
19	GF19 L T54	.213	.002-.006
20	GF20 L T64	.252	.002-.006

Threading - Partial Profile 60°

External Thread

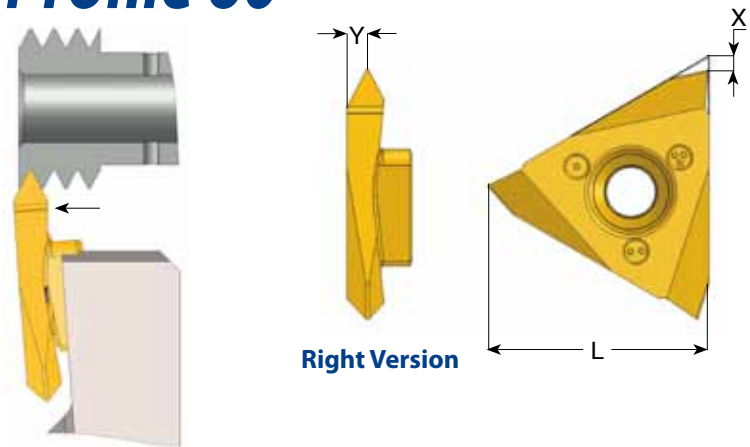

Right hand cutting

L	mm	TPI	Ordering Code	X	Y
19	0.5-1.5	48-16	GT19 R A60	.11	.043
	1.75-3.0	14-8	GT19 R G60	.11	.067
	0.5-3.0	48-8	GT19 R AG60	.11	.067

Left hand cutting

L	mm	TPI	Ordering Code	X	Y
19	0.5-1.5	48-16	GT19 L A60	.11	.043
	1.75-3.0	14-8	GT19 L G60	.11	.067
	0.5-3.0	48-8	GT19 L AG60	.11	.067

Threading - Partial Profile 55°

External Thread

Right hand cutting

L	mm	TPI	Ordering Code	X	Y
19	0.5-1.5	48-16	GT19 R A55	.11	.039
	1.75-3.0	14-8	GT19 R G55	.11	.067
	0.5-3.0	48-8	GT19 R AG55	.11	.067

Left hand cutting

L	mm	TPI	Ordering Code	X	Y
19	0.5-1.5	48-16	GT19 L A55	.11	.039
	1.75-3.0	14-8	GT19 L G55	.11	.067
	0.5-3.0	48-8	GT19 L AG55	.11	.067

Threading - ISO metric 60°

External Thread

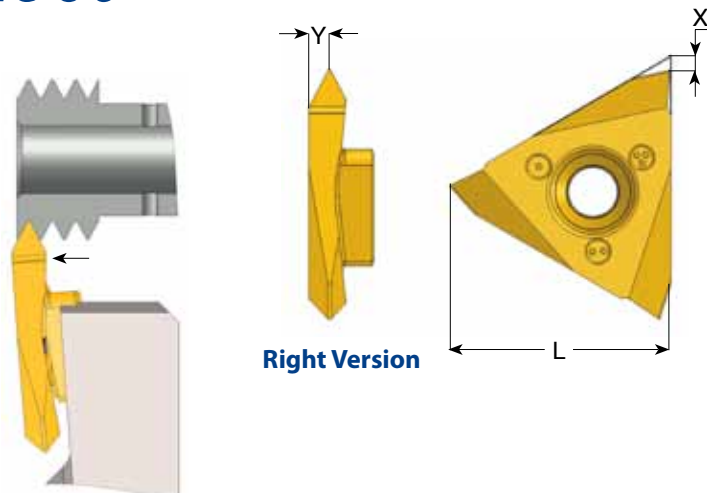

Right Version

Right hand cutting

L	mm	Ordering Code	X	Y
19	0.5	GT19 R 0.5ISO	.11	.024
	0.7	GT19 R 0.7ISO	.11	.028
	0.75	GT19 R 0.75ISO	.11	.028
	0.8	GT19 R 0.8ISO	.11	.028
	1.0	GT19 R 1.0ISO	.11	.032
	1.25	GT19 R 1.25ISO	.11	.039
	1.5	GT19 R 1.5ISO	.11	.043
	1.75	GT19 R 1.75ISO	.11	.051

Left hand cutting

L	mm	Ordering Code	X	Y
19	0.5	GT19 L 0.5ISO	.11	.024
	0.7	GT19 L 0.7ISO	.11	.028
	0.75	GT19 L 0.75ISO	.11	.028
	0.8	GT19 L 0.8ISO	.11	.028
	1.0	GT19 L 1.0ISO	.11	.032
	1.25	GT19 L 1.25ISO	.11	.039
	1.5	GT19 L 1.5ISO	.11	.043
	1.75	GT19 L 1.75ISO	.11	.051

Threading - UN unified 60°

External Thread

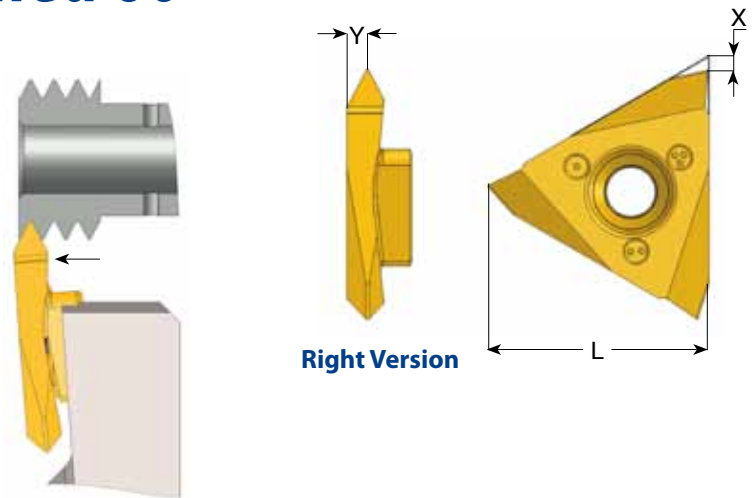

Right Version

Right hand cutting

L	TPI	Ordering Code	X	Y
19	72	GT19 R 72UN	.11	.016
	56	GT19 R 56UN	.11	.024
	40	GT19 R 40UN	.11	.028
	32	GT19 R 32UN	.11	.028
	24	GT19 R 24UN	.11	.032
	20	GT19 R 20UN	.11	.039

Left hand cutting

L	TPI	Ordering Code	X	Y
19	72	GT19 L 72UN	.11	.016
	56	GT19 L 56UN	.11	.024
	40	GT19 L 40UN	.11	.028
	32	GT19 L 32UN	.11	.028
	24	GT19 L 24UN	.11	.032
	20	GT19 L 20UN	.11	.039

Product Identification - Toolholders

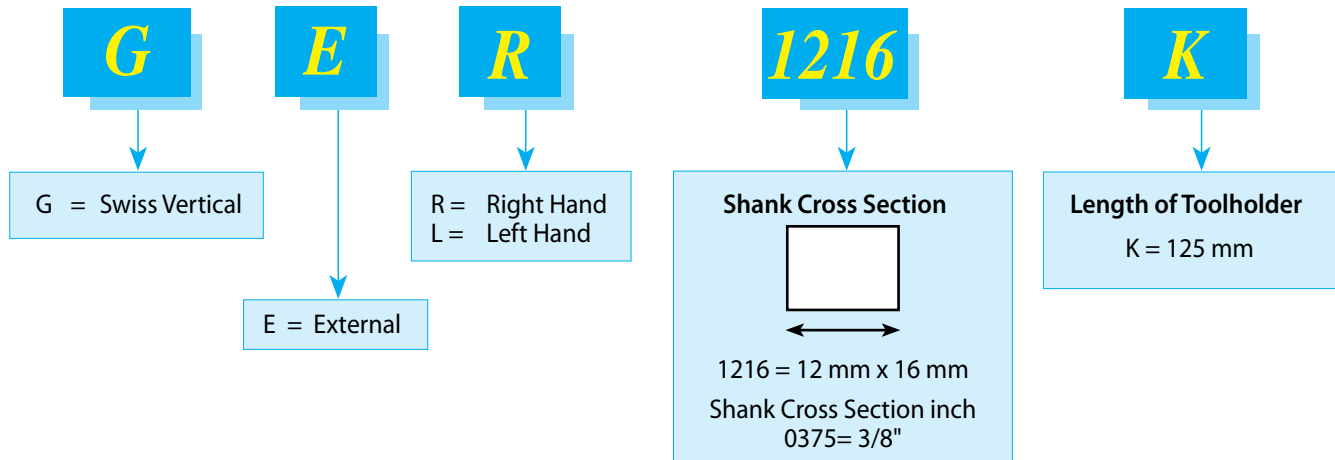

External Toolholders

- Coolant through toolholders, for external turning in Swiss style lathes.
- The high pressure coolant is directed towards the insert cutting edge in order to evacuate the chips created and avoid build up edge.
- Including a coolant connector for a quick setup on the machine.

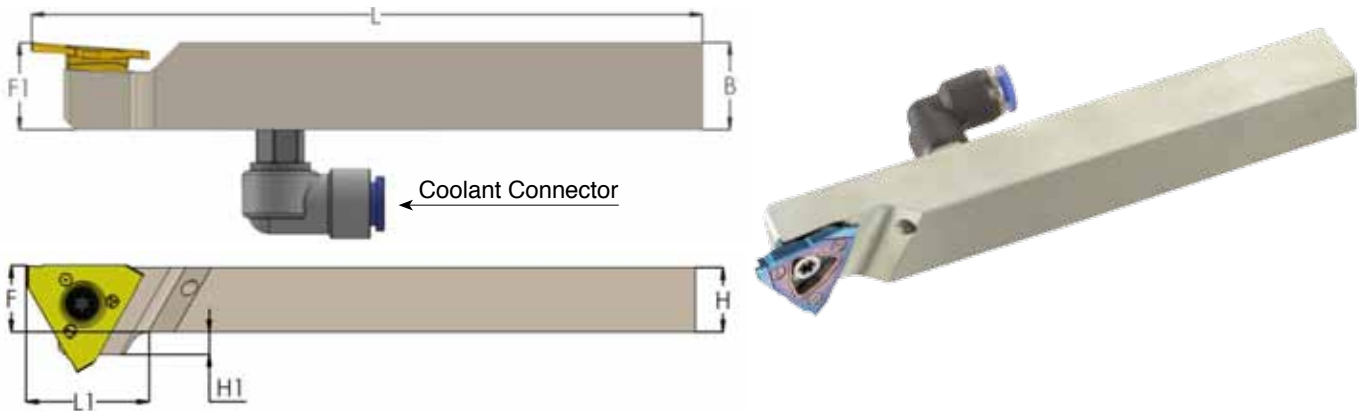

Right hand - Metric holders

Ordering Code	B (mm)	H (mm)	L1	L	F	F1	H1	Insert Screw	Torx Key	*Coolant connector (mm)
**GER 0816 K	16	8	.67	4.9	.32	.63	.32	S21	K21	-
GER 1016 K	16	10	.67	4.9	.39	.63	.24	S21	K21	Ø4 / Ø6
GER 1216 K	16	12	.67	4.9	.47	.63	.16	S21	K21	Ø4 / Ø6
GER 1616 K	16	16	-	4.9	.63	.63	0	S21	K21	Ø4 / Ø6
GER 2020 K	20	20	-	4.9	.79	.79	0	S21	K21	Ø4 / Ø6
GER 2525 M	25	25	-	5.9	.98	.98	0	S21	K21	Ø4 / Ø6

* Diameter of coolant pipe

** Without coolant

Right hand - Inch holders

Ordering Code	B	H	L1	L	F	F1	H1	Insert Screw	Torx Key	*Coolant connector (mm)
GER 0375 K	.625	.375	.67	4.9	.38	.63	.25	S21	K21	Ø4 / Ø6
GER 0500 K	.625	.500	.67	4.9	.50	.63	.13	S21	K21	Ø4 / Ø6
GER 0625 K	.625	.625	-	4.9	.63	.63	0	S21	K21	Ø4 / Ø6
GER 0750 K	.750	.750	-	4.9	.75	.75	0	S21	K21	Ø4 / Ø6
GER 1000 M	1.000	1.000	-	5.9	1.00	1.00	0	S21	K21	Ø4 / Ø6

* Diameter of coolant pipe

Left hand - Metric holders

Ordering Code	B (mm)	H (mm)	L1	L	F	F1	H1	Insert Screw	Torx Key	*Coolant connector (mm)
**GEL 0816 K	16	8	.67	4.9	.32	.63	.32	S21	K21	-
GEL 1016 K	16	10	.67	4.9	.39	.63	.24	S21	K21	Ø4 / Ø6
GEL 1216 K	16	12	.67	4.9	.47	.63	.16	S21	K21	Ø4 / Ø6
GEL 1616 K	16	16	-	4.9	.63	.63	0	S21	K21	Ø4 / Ø6
GEL 2020 K	20	20	-	4.9	.79	.79	0	S21	K21	Ø4 / Ø6
GEL 2525 M	25	25	-	5.9	.98	.98	0	S21	K21	Ø4 / Ø6

* Diameter of coolant pipe

** Without coolant

Left hand - Inch holders

Ordering Code	B	H	L1	L	F	F1	H1	Insert Screw	Torx Key	*Coolant connector (mm)
GEL 0375 K	.625	.375	.67	4.9	.38	.63	.25	S21	K21	Ø4 / Ø6
GEL 0500 K	.625	.500	.67	4.9	.50	.63	.13	S21	K21	Ø4 / Ø6
GEL 0625 K	.625	.625	-	4.9	.63	.63	0	S21	K21	Ø4 / Ø6
GEL 0750 K	.750	.750	-	4.9	.75	.75	0	S21	K21	Ø4 / Ø6
GEL 1000 M	1.000	1.000	-	5.9	1.00	1.00	0	S21	K21	Ø4 / Ø6

* Diameter of coolant pipe

Swiss Line Slim Holders

For cut-off when using sub-spindle

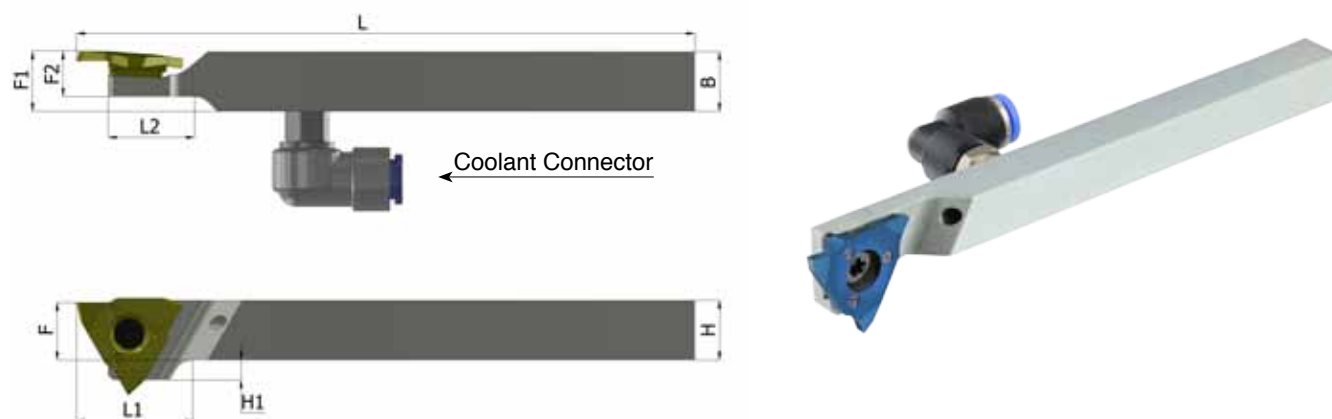

Metric Shank

Ordering Code	B=H	L1	L2	L	F	F1	F2	H1	Insert Screw	Torx Key	*Coolant connector
GERS 1010 K	10	17	11	125	10	10	10.0	6	S21XS	K21	Ø4 / Ø6
GERS 1212 K	12	17	11	125	12	12	9.5	4	S21XS	K21	Ø4 / Ø6
GERS 1616 K	16	-	11	125	16	16	9.5	0	S21XS	K21	Ø4 / Ø6
GERS 2020 K	20	-	11	125	20	20	9.5	0	S21XS	K21	Ø4 / Ø6

* Diameter of coolant pipe

Right hand

Ordering Code	B=H	L1	L2	L	F	F1	F2	H1	Insert Screw	Torx Key	*Coolant connector
GERS 0375 K	.375	.67	.43	4.9	.375	.375	.375	.250	S21XS	K21	Ø4 / Ø6
GERS 0500 K	.500	.67	.43	4.9	.500	.500	.375	.125	S21XS	K21	Ø4 / Ø6
GERS 0625 K	.625	-	.43	4.9	.625	.625	.375	0	S21XS	K21	Ø4 / Ø6
GERS 0750 K	.750	-	.43	4.9	.750	.750	.375	0	S21XS	K21	Ø4 / Ø6

* Diameter of coolant pipe

Grooving - Parting Off - Turning - Profiling - Threading Working Method

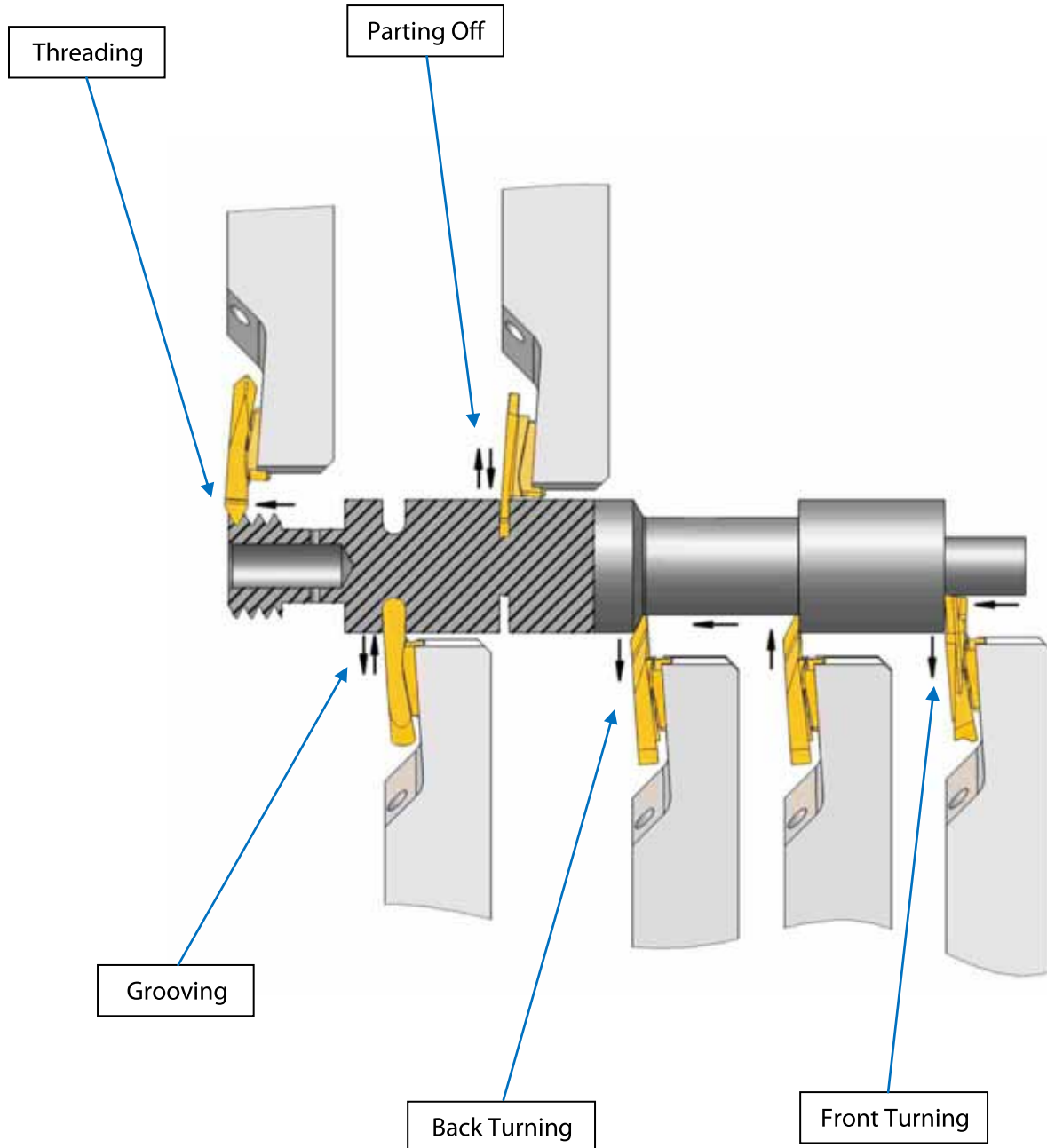

Carbide Grades

BLU

PVD triple layer coated Sub-Micron grade for Steel, Stainless Steels, Titanium and hard materials.

K20

Uncoated Sub-Micron carbide grade for Aluminum and non-ferrous materials, Stainless Steels and Titanium.

Cutting Data

ISO Standard	Materials	Cutting Speed ft/min	
		K20	BLU
P	Low & Medium Carbon Steels <0.55%C	-	260-490
	High Carbon Steels ≥0.55%C	-	230-395
	Alloy Steels, Treated Steels	-	130-260
M	Stainless Steel-Free Cutting	100-260	200-395
	Stainless Steel-Austenitic	65-230	100-295
	Cast Steels	100-260	165-395
K	Cast Iron	165-395	200-490
N	Aluminium ≤12%Si, Copper	395-820	-
	Aluminium >12%Si	295-656	-
	Synthetics, Duroplastics, Thermoplastics	230-490	-
S	Nickel Alloys, Titanium Alloys	65-165	100-230
H	Hardened Steel, 45-50HRc	-	65-165



Carbide Shank Turning Tool Holders and Insert



Contents:

Page:

Carbide Shank Turning Tool Holders and Insert 164

Carbide Shank Boring Bars and Inserts

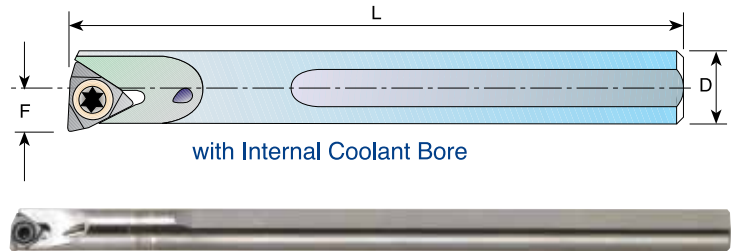

D	Ordering Code	L	F	Min. Bore Dia.	Screw	Key
1/4	SIR 0250 H06CT	4	.14	.27	S6	K6
5/16	SIR 0310 K06CT	5	.17	.34	S6	K6

Insert Ordering Code: 06 IR TURN BMA

Nose radius R= 0.2mm

For turning small bores see pages 81-87

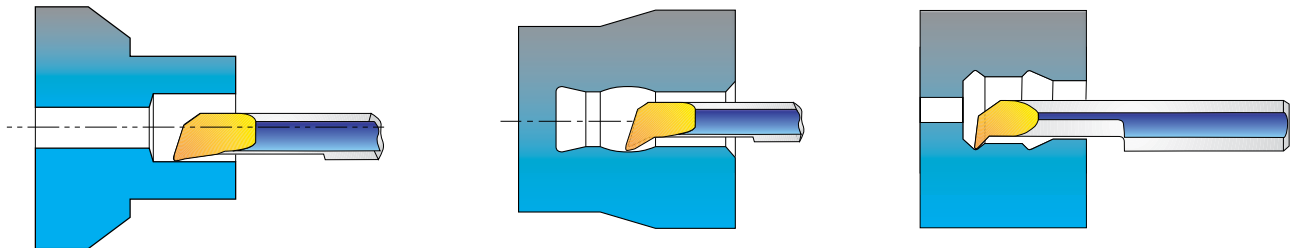

Thread Whirling Tools



For Perfect Long Threads on Swiss Type Machines

Thread Whirling is a fast and accurate way to thread long, small diameter parts in exotic materials such as titanium, stainless steel and Inconel.

Whirling inserts and holders can produce a wide range of medical parts such as dental implants and bone screws, automotive parts and semiconductor small parts.

Cutting is the result of the whirling ring rotating eccentrically at high speed about the slowly rotating workpiece. The advancement of the workpiece rotationally and the advancement of the tool head longitudinally correspond to the thread pitch required.

Turning direction of the whirling unit

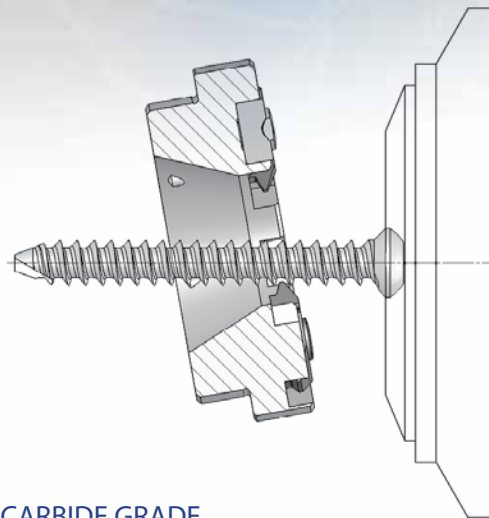

Turning direction of the bar



CARBIDE GRADE

BMA - PVD TiAlN coated submicrograin for stainless steel, exotic materials.

Contents:

Thread Whirling Advantages	166
Product Identification	166
Ordering according to Machine Type or Model	167

Page:

Contents:

Case study	168
Specials	168

Page:

Thread Whirling Advantages

Thread Whirling offers several advantages over single point threading:

Enabling production of small diameter long threads when used on Swiss type machines, the thread whirling spindle works close to the guide bushing for increased support and rigidity.

Increased Productivity:

Thread Whirling is performed in a single pass, resulting in a shorter machining time. This eliminates multiple passes required for a single point threading. Thread whirling allows working at high feed rates and consequently short cycle times.

Very high surface quality and accurate geometry:

The use of up to 8 cutting edges, higher concentricity, special cutting edge geometry and ideal chip removal, enable top quality surfaces to be produced without burr.

Long tool life:

Whirling inserts have a stronger cutting edge than single point tools, because cutter side clearance is achieved by rotating the whirling spindle, not by relieving material under the cutting edge.

Faster Setup:

Thread whirling eliminates special support devices and expensive startup development costs.

Compensation of large helix angles:

Large helix angles can be compensated by adjusting the whirling unit.

- One toolholder can be used for various applications.
- All toolholders are standard stock items.
- Inserts are made for each application as a special item.
- The toolholders are designed according to different machine types and manufacturers.
- Special adaptors for machine heads are available as stock items.

Product Identification

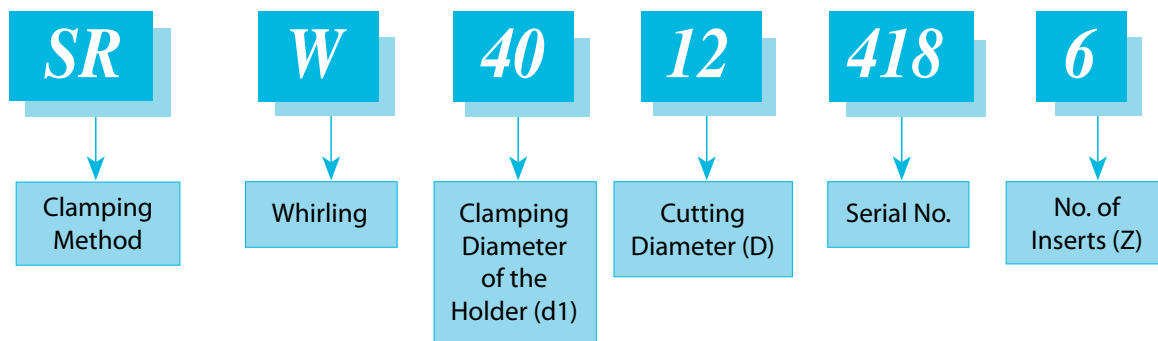

Toolholders

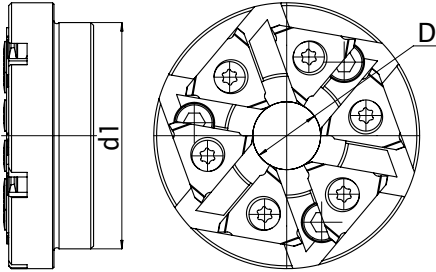

Machine		Drive Unit	Whirling Head Ordering Code	Z	D	d1	Insert Size	Insert Screw	Torx Key
Type	Model								
Star	SV12 / SV20	Star	SRW4012 418 - 6	6	12	40	16	SW16	KW16
			SRW4012 424 - 8	8			11	SW11	KW11
	SR20 / ECAS20		SRW4012 419 - 6	6	12	40	16	SW16	KW16
			SRW4012 425 - 8	8			11	SW11	KW11
Citizen	M12 / M16	PCM	SRW4512 422 - 6	6	12	45	16	SW16	KW16
			SRW4512 426 - 8	8			11	SW11	KW11
	M20 / M32		SRW4512 423 - 6	6	12	45	16	SW16	KW16
			SRW4512 427 - 8	8			11	SW11	KW11
Tornos	Deco 13 / 20	Tornos	SRW4012 420 - 6	6	12	40	16	SW16	KW16
	Evo Deco 16 / Deco 13	W & F	SRW4012 419 - 6						
Traub	TNL26 / TNK36	Traub	SRW4116 421 - 6	6	16	41	16	SW16	KW16
Hanwha	XD20	Maduala	SRW4012 604 - 6	6	12	40	16	SW16	KW16
Maier	ML20D	PCM	SRW4012 417 - 5	5	12	40	16	SW16	KW16
Nexturn	SA20	PCM	SRW4512 642 - 6	6	12	45	16	SW16	KW16
	SA20	WTO	SRW4212 557 - 6	6	12	45	16	SW16	KW16

Case Study

Machine:	Nexturn SA-20
Drive unit:	WTO
Application:	Bone screw
Material:	Ti-6Al-4V ELI
Carmex holder:	SRW4212 557-6
Vc [m/min]:	38
Tooth load [mm/tooth]:	0.04
No. of parts:	806

SPECIALS
ARE OUR SPECIALTY



Milling Tools

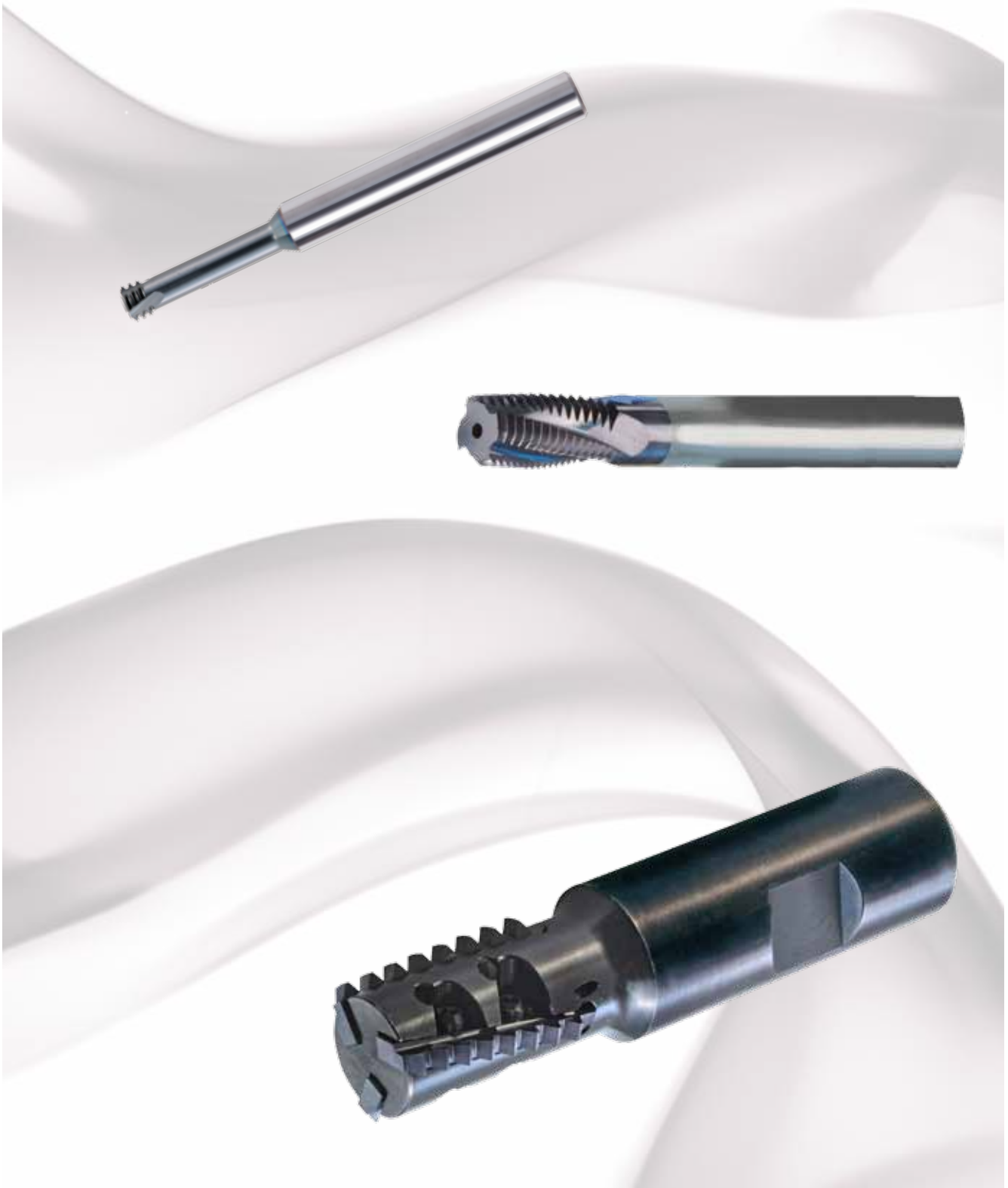

CONTENTS:

Page:

Mill-Thread Inserts and Kits

171-182

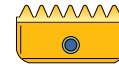

Mill-Thread Toolholders

183-188



D-Thread

189-192



Spiral Mill-Thread

193-204



Deep Reach Mill-Thread

205-208



CMT

209-234



Mill-Thread Solid Carbide

235-260



Mini Mill-Thread

261-276



DMT - 3 in 1 - Drill, Thread, Chamfer

277-282



HARD 

283-288



Mill-Thread Technical Section

289-308



Solid Carbide Grooving Tools

309-312



Supercut Roughers

313-322



Mini Chamfer

323-328



Mill - Thread Inserts and Kits



**Mill-Thread tools for threading on CNC milling machines
by using helical interpolation programs**

Advantages of Mill-Thread Tools

- Same toolholder and insert can produce both right-hand and left-hand threads.
- A single insert & toolholder can produce a given thread on many diameters (External & Internal).
- Prismatic shape of insert's tail ensures exact and reliable clamping in the toolholder.
- Most inserts are double sided, having two cutting edges.
- Thread is produced in one tool pass.
- MT tools can produce tapered threads.
- Improved productivity thanks to increased cutting speeds and multitooth type carbide inserts.
- Threading to one pitch of a shoulder in a blind hole.
- Longer tool life thanks to a special multilayer coating process.
- Lower tooling costs, considerably less expensive than using taps and dies.
- Since lower machine power is required, a smaller machine can produce larger threads in a single operation with less idle time and tool changes.

Contents:	Page:	Contents:	Page:
Product Identification	172	NPSM	178
ISO	173	PG - DIN 40430	178
UN	174	UNJ	179
WHIT	175	American Buttress	179
BSPT	175	Acme	180
NPT	176	API RD	180
NPTF	176	Internal ISO Kits	181
NPS	177	Special Tools	182
NPSF	177		

Product Identification

Mill-Thread Inserts Ordering Codes

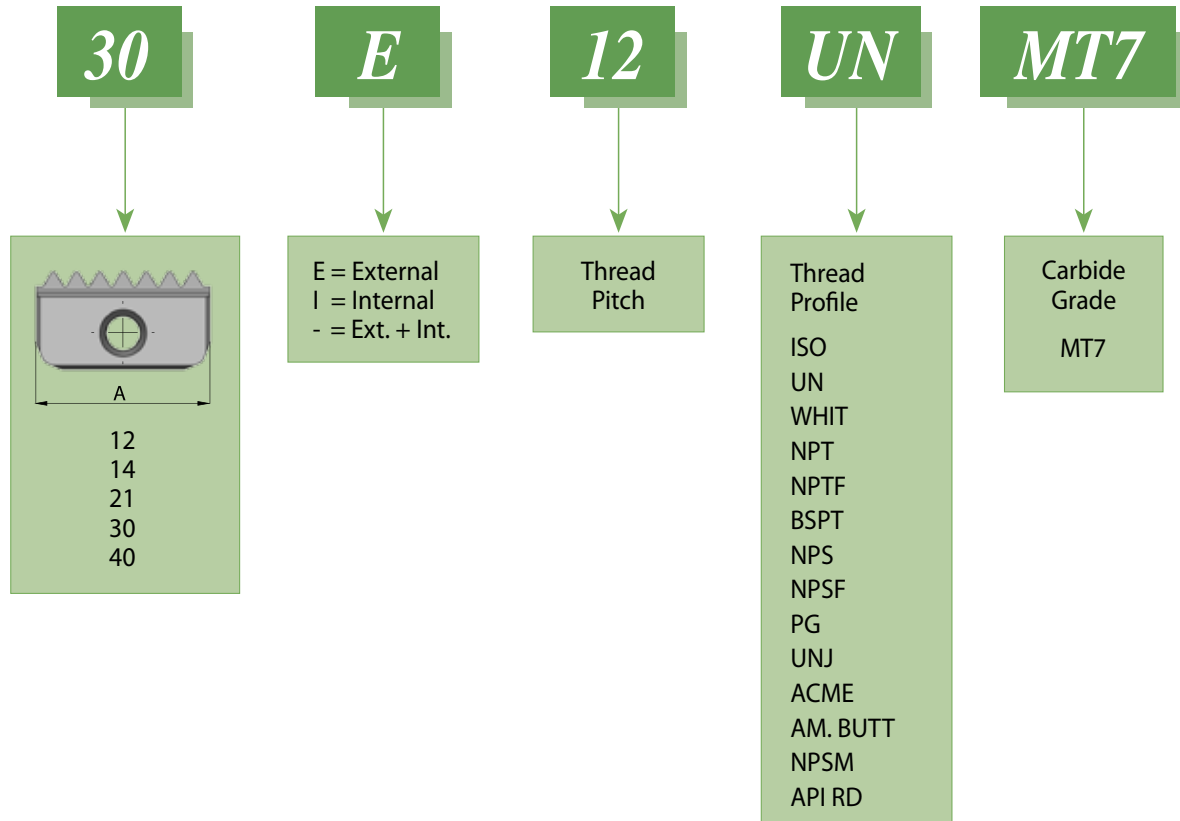

	Insert Size = A				
	12 mm	14 mm	21 mm	30 mm	40 mm
H	.248	.295	.472	.630	.787
T	.114	.122	.185	.217	.248

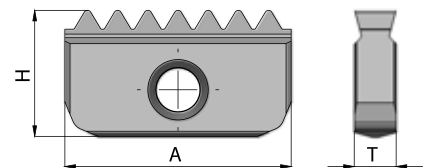

ISO

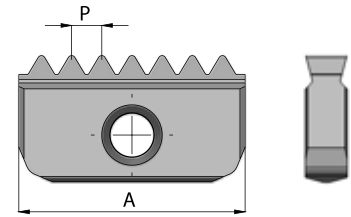
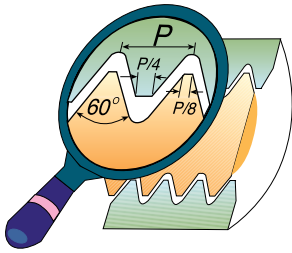

Pitch mm		Insert Size = A				
		12 mm .472	14 mm .551	21 mm .827	30 mm 1.181	40 mm 1.575
0.5	Ext.					
0.5	Int.	* 12 I 0.5 ISO	14 I 0.5 ISO			
0.75	Ext.		14 E 0.75 ISO			
0.75	Int.	* 12 I 0.75 ISO	14 I 0.75 ISO			
1.0	Ext.		14 E 1.0 ISO	21 E 1.0 ISO		
1.0	Int.	* 12 I 1.0 ISO	14 I 1.0 ISO	21 I 1.0 ISO		
1.25	Ext.		14 E 1.25 ISO			
1.25	Int.	* 12 I 1.25 ISO	14 I 1.25 ISO			
1.5	Ext.		14 E 1.5 ISO	21 E 1.5 ISO	30 E 1.5 ISO	40 E 1.5 ISO
1.5	Int.	* 12 I 1.5 ISO	14 I 1.5 ISO	21 I 1.5 ISO	30 I 1.5 ISO	40 I 1.5 ISO
1.75	Ext.		14 E 1.75 ISO			
1.75	Int.		14 I 1.75 ISO	21 I 1.75 ISO		
2.0	Ext.		14 E 2.0 ISO	21 E 2.0 ISO	30 E 2.0 ISO	40 E 2.0 ISO
2.0	Int.		14 I 2.0 ISO	21 I 2.0 ISO	30 I 2.0 ISO	40 I 2.0 ISO
2.5	Ext.		14 E 2.5 ISO	21 E 2.5 ISO		
2.5	Int.		14 I 2.5 ISO	21 I 2.5 ISO		
3.0	Ext.			21 E 3.0 ISO	30 E 3.0 ISO	40 E 3.0 ISO
3.0	Int.			21 I 3.0 ISO	30 I 3.0 ISO	40 I 3.0 ISO
3.5	Ext.				30 E 3.5 ISO	
3.5	Int.			21 I 3.5 ISO	30 I 3.5 ISO	40 I 3.5 ISO
4.0	Ext.				30 E 4.0 ISO	40 E 4.0 ISO
4.0	Int.				30 I 4.0 ISO	40 I 4.0 ISO
4.5	Ext.					
4.5	Int.				30 I 4.5 ISO	40 I 4.5 ISO
5.0	Ext.					40 E 5.0 ISO
5.0	Int.				30 I 5.0 ISO	40 I 5.0 ISO
5.5	Ext.					
5.5	Int.				30 I 5.5 ISO	40 I 5.5 ISO
6.0	Ext.					40 E 6.0 ISO
6.0	Int.					40 I 6.0 ISO

* One cutting edge

Order example: 14 I 1.5 ISO MT7

UN UNC, UNF, UNEF, UNS

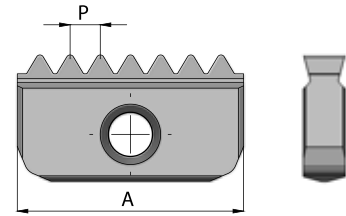
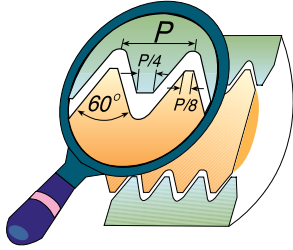

Pitch TPI		Insert Size = A				
		12 mm .472	14 mm .551	21 mm .827	30 mm 1.181	40 mm 1.575
32	Ext.		14 E 32 UN			
32	Int.	* 12 32 UN	14 32 UN			
28	Ext.		14 E 28 UN			
28	Int.	* 12 28 UN	14 28 UN			
27	Ext.					
27	Int.		14 27 UN			
24	Ext.		14 E 24 UN	21 E 24 UN		
24	Int.	* 12 24 UN	14 24 UN	21 24 UN		
20	Ext.		14 E 20 UN	21 E 20 UN	30 E 20 UN	
20	Int.	* 12 20 UN	14 20 UN	21 20 UN	30 20 UN	
18	Ext.		14 E 18 UN	21 E 18 UN	30 E 18 UN	
18	Int.	* 12 18 UN	14 18 UN	21 18 UN	30 18 UN	
16	Ext.		14 E 16 UN	21 E 16 UN	30 E 16 UN	40 E 16 UN
16	Int.	* 12 16 UN	14 16 UN	21 16 UN	30 16 UN	40 16 UN
14	Ext.		14 E 14 UN	21 E 14 UN	30 E 14 UN	40 E 14 UN
14	Int.		14 14 UN	21 14 UN	30 14 UN	40 14 UN
13	Ext.		14 E 13 UN			
12	Ext.		14 E 12 UN	21 E 12 UN	30 E 12 UN	40 E 12 UN
12	Int.		14 12 UN	21 12 UN	30 12 UN	40 12 UN
11	Ext.		14 E 11 UN	21 E 11 UN		
11	Int.		14 11 UN			
10	Ext.		* 14 E 10 UN	21 E 10 UN	30 E 10 UN	40 E 10 UN
10	Int.		14 10 UN	21 10 UN	30 10 UN	40 10 UN
9	Ext.					
9	Int.		** 14 9 UN			
8	Ext.				30 E 8 UN	40 E 8 UN
8	Int.			21 8 UN	30 8 UN	40 8 UN
7	Ext.					
7	Int.			21 7 UN		
6	Ext.				30 E 6 UN	40 E 6 UN
6	Int.				30 6 UN	40 6 UN
5	Ext.					
5	Int.				30 5 UN	
4.5	Ext.					
4.5	Int.					40 4.5UN
4	Ext.					
4	Int.					40 4 UN

* One cutting edge

** Cannot be used with carbide shank Toolholders.

Order example: 21 | 18 UN MT7

WHIT BSW, BSF, BSP

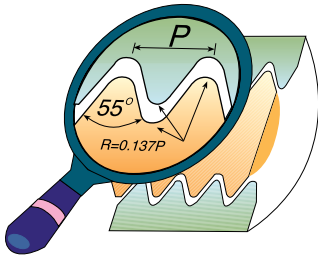

Same Insert for External and Internal thread.

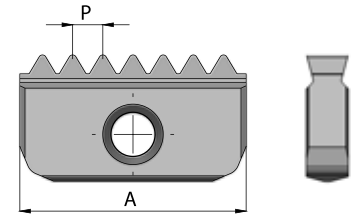

Pitch TPI	Insert Size = A				
	12 mm .472	14 mm .551	21 mm .827	30 mm 1.181	40 mm 1.575
24		14-24 W			
20		14-20 W	21-20 W		
19	* 12 - 19 W	14-19 W	21-19 W		
18		14-18 W			
16		14-16 W	21-16 W	30-16 W	
14		14-14 W	21-14 W	30-14 W	
12		14-12 W			
11		* 14-11 W	21-11 W	30-11 W	40-11 W
10			21-10 W		
8					40- 8 W

* One cutting edge
Order example: 21-11 W MT7

BSPT

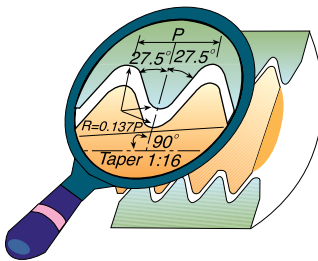

Conical pipe thread inserts are one-sided and may be used for both External and Internal threading.

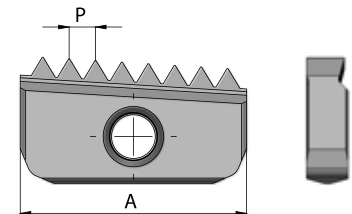

Pitch TPI	Insert Size = A				
	12 mm .472	14 mm .551	21 mm .827	30 mm 1.181	40 mm 1.575
19	12-19 BSPT	14-19 BSPT			
14		14-14 BSPT	21-14 BSPT		
11			21-11 BSPT	30-11 BSPT	40-11 BSPT

Order example: 14-19 BSPT MT7
For conical preparation end mills see page 253

NPT

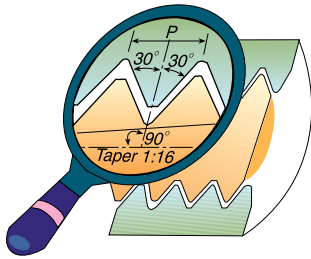

Conical pipe thread inserts are one-sided and may be used for both External and Internal threading.

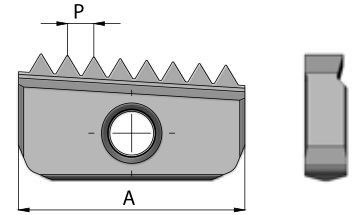

Pitch TPI	Insert Size = A				
	12 mm .472	14 mm .551	21 mm .827	30 mm 1.181	40 mm 1.575
18	12-18 NPT	14-18 NPT			
14		14-14 NPT	21-14 NPT		
11.5			21-11.5 NPT	30-11.5 NPT	40-11.5 NPT
8				30- 8 NPT	40- 8 NPT

Order example: 30-11.5 NPT MT7

NPTF

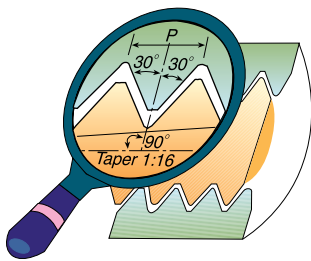

Conical pipe thread inserts are one-sided and may be used for both External and Internal threading.

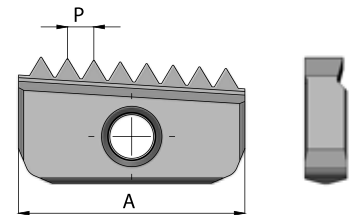

Pitch TPI	Insert Size = A				
	12 mm .472	14 mm .551	21 mm .827	30 mm 1.181	40 mm 1.575
18	12-18 NPTF	14-18 NPTF			
14		14-14 NPTF	21-14 NPTF		
11.5			21-11.5 NPTF	30-11.5 NPTF	40-11.5 NPTF
8				30- 8 NPTF	40- 8 NPTF

Order example: 21-14 NPTF MT7

For conical preparation end mills see page 253

NPS

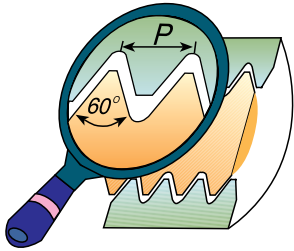

Same Insert for External and Internal thread

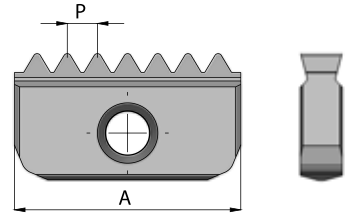

Pitch TPI	Insert Size = A				
	12 mm .472	14 mm .551	21 mm .827	30 mm 1.181	40 mm 1.575
18	* 12-18 NPS	14-18 NPS			
14		14-14 NPS	21-14 NPS		
11.5			21-11.5 NPS	30-11.5 NPS	40-11.5 NPS
8				30- 8 NPS	40- 8 NPS

Order example: 16 ER 14 NPS MXC

NPSF

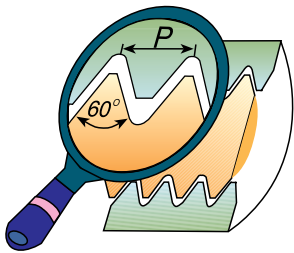

Same Insert for External and Internal thread

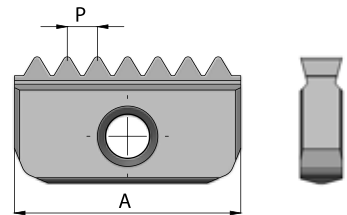

Pitch TPI	Insert Size = A				
	12 mm .472	14 mm .551	21 mm .827	30 mm 1.181	40 mm 1.575
18	* 12-18 NPSF	14-18 NPSF			
14		14-14 NPSF	21-14 NPSF		
11.5			21-11.5 NPSF	30-11.5 NPSF	40-11.5 NPSF
8				30- 8 NPSF	40- 8 NPSF

Order example: 21-14 NPSF MT7

* One cutting edge

NPSM

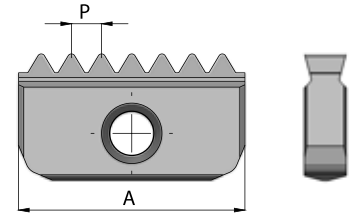
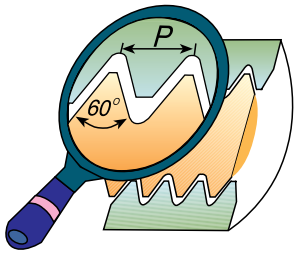

Pitch TPI		Insert Size = A				
		12 mm .472	14 mm .551	21 mm .827	30 mm 1.181	40 mm 1.575
18	Ext.		14 E 18 NPSM			
18	Int.	12 I 18 NPSM	14 I 18 NPSM			
14	Ext.			21 E 14 NPSM		
14	Int.		14 I 14 NPSM	21 I 14 NPSM		
11.5	Ext.			21 E 11.5 NPSM	30 E 11.5 NPSM	40 E 11.5 NPSM
11.5	Int.			21 I 11.5 NPSM	30 I 11.5 NPSM	40 I 11.5 NPSM
8	Ext.				30 E 8 NPSM	40 E 8 NPSM
8	Int.				30 I 8 NPSM	40 I 8 NPSM

Order example: 21 I 11.5 NPSM MT7

PG - DIN 40430

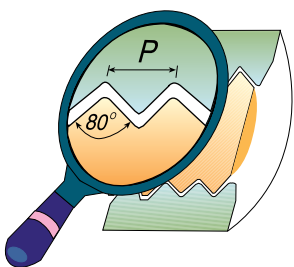

Same Insert for External and Internal thread

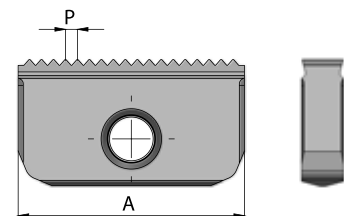

Pitch TPI	Insert Size = A		
	14 mm .551	21 mm .827	30 mm 1.181
18	14-18 PG (PG 9, 11, 13.5, 16)	21-18 PG (PG 16)	
16		21-16 PG (PG 21, 29, 36, 42, 48)	30-16 PG (PG 36, 42, 48)

Order example: 21-18 PG MT7

UNJ

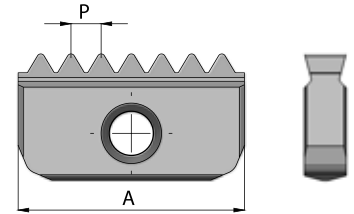
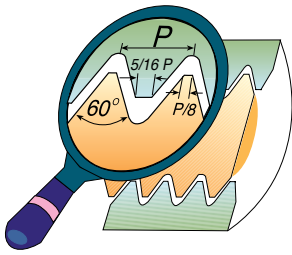

Pitch TPI		Insert Size = A	
		14 mm .551	21 mm .827
24	Ext.	14 E 24 UNJ	21 E 24 UNJ
24	Int.	14 I 24 UNJ	21 I 24 UNJ
20	Ext.	14 E 20 UNJ	21 E 20 UNJ
20	Int.	14 I 20 UNJ	21 I 20 UNJ
18	Ext.	14 E 18 UNJ	21 E 18 UNJ
18	Int.	14 I 18 UNJ	21 I 18 UNJ
16	Ext.	14 E 16 UNJ	21 E 16 UNJ
16	Int.	14 I 16 UNJ	21 I 16 UNJ
14	Ext.	14 E 14 UNJ	21 E 14 UNJ
14	Int.	14 I 14 UNJ	21 I 14 UNJ
12	Ext.	14 E 12 UNJ	21 E 12 UNJ
12	Int.	14 I 12 UNJ	21 I 12 UNJ

Order example: 21E 16 UNJ MT7

American Buttress

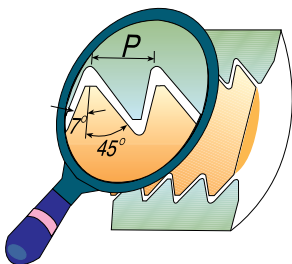

ABUT thread inserts are one-sided and may be used for both External and Internal threading

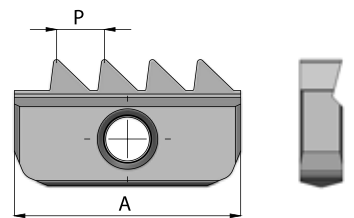

Pitch TPI	Insert Size = A		
	21 mm .827	30 mm 1.181	40 mm 1.575
16	21 - 16 ABUT	30 - 16 ABUT	
12	21 - 12 ABUT	30 - 12 ABUT	
10	21 - 10 ABUT	30 - 10 ABUT	
8	21 - 8 ABUT	30 - 8 ABUT	
6		30 - 6 ABUT	
4		* 30 - 4 ABUT	40 - 4 ABUT

Order example: 30 - 6 ABUT MT7

* Inserts to be used only on Multi-Insert toolholders see page 187

ACME

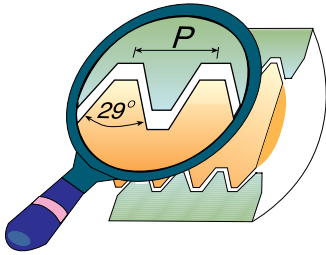

Inserts for Internal threads

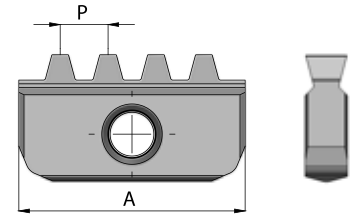

Pitch TPI		Insert Size = A		
		21 mm .827	30 mm 1.181	40 mm 1.575
12	Int.	21 12 ACME	30 12 ACME	
10	Int.	21 10 ACME	30 10 ACME	
8	Int.	21 8 ACME	30 8 ACME	
6	Int.		30 6 ACME	
5	Int.		30 5 ACME	
4	Int.		* 30 4 ACME	40 4 ACME
3.5	Int.			40 3.5 ACME
3	Int.			** 40 3 ACME

Order example: 21 | 8 ACME MT7

* Inserts to be used only on Multi-Insert toolholders see page 187

** One cutting edge

API RD

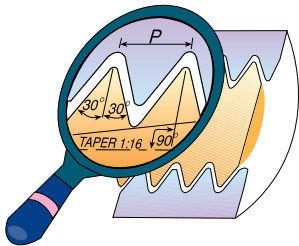

Same Insert for External and Internal thread

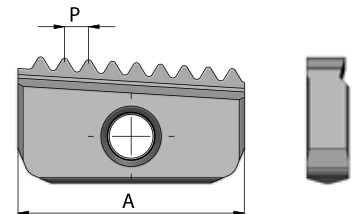

Pitch TPI		Insert Size = A		
		21 mm .827	30 mm 1.181	40 mm 1.575
10		21 - 10 API RD	30 - 10 API RD	
8			30 - 8 API RD	40 - 8 API RD

Order example: 30 - 8 API RD MT7

Internal UN Kits



MTK 12 I UN	MTK 14 I UN
<u>INSERTS</u>	<u>INSERTS</u>
12 I 32 UN	14 I 24 UN
12 I 24 UN	14 I 24 UN
12 I 20 UN	14 I 20 UN
12 I 20 UN	14 I 20 UN
12 I 16 UN	14 I 16 UN
12 I 16 UN	14 I 16 UN
<u>TOOLHOLDER</u>	<u>TOOLHOLDER</u>
SR 0375 H12	SR 0670 H14
<u>KEY</u>	<u>KEY</u>
K12	K14
<u>SCREW</u>	<u>SCREW</u>
S12	S14

Order example : MTK 14 I UN

Special Tools



In addition to standard products, Carmex manufactures special tools and inserts according to customers' requests. Special tools are supplied in short delivery times.

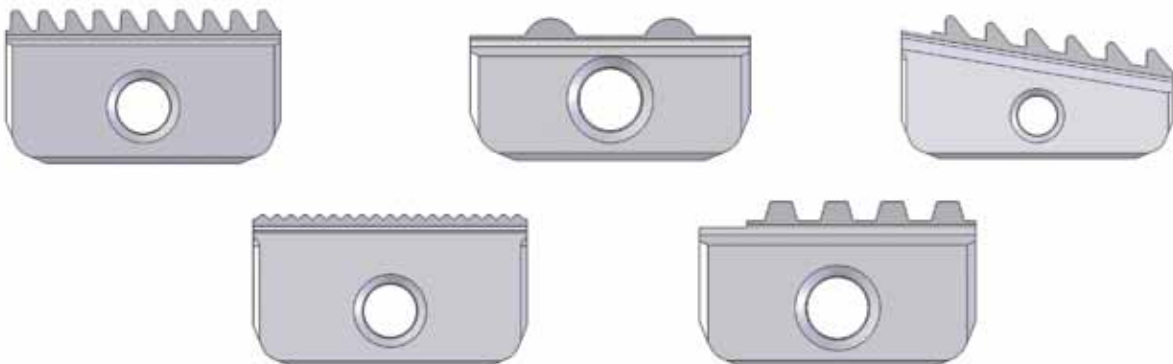

Mill-Thread Toolholders

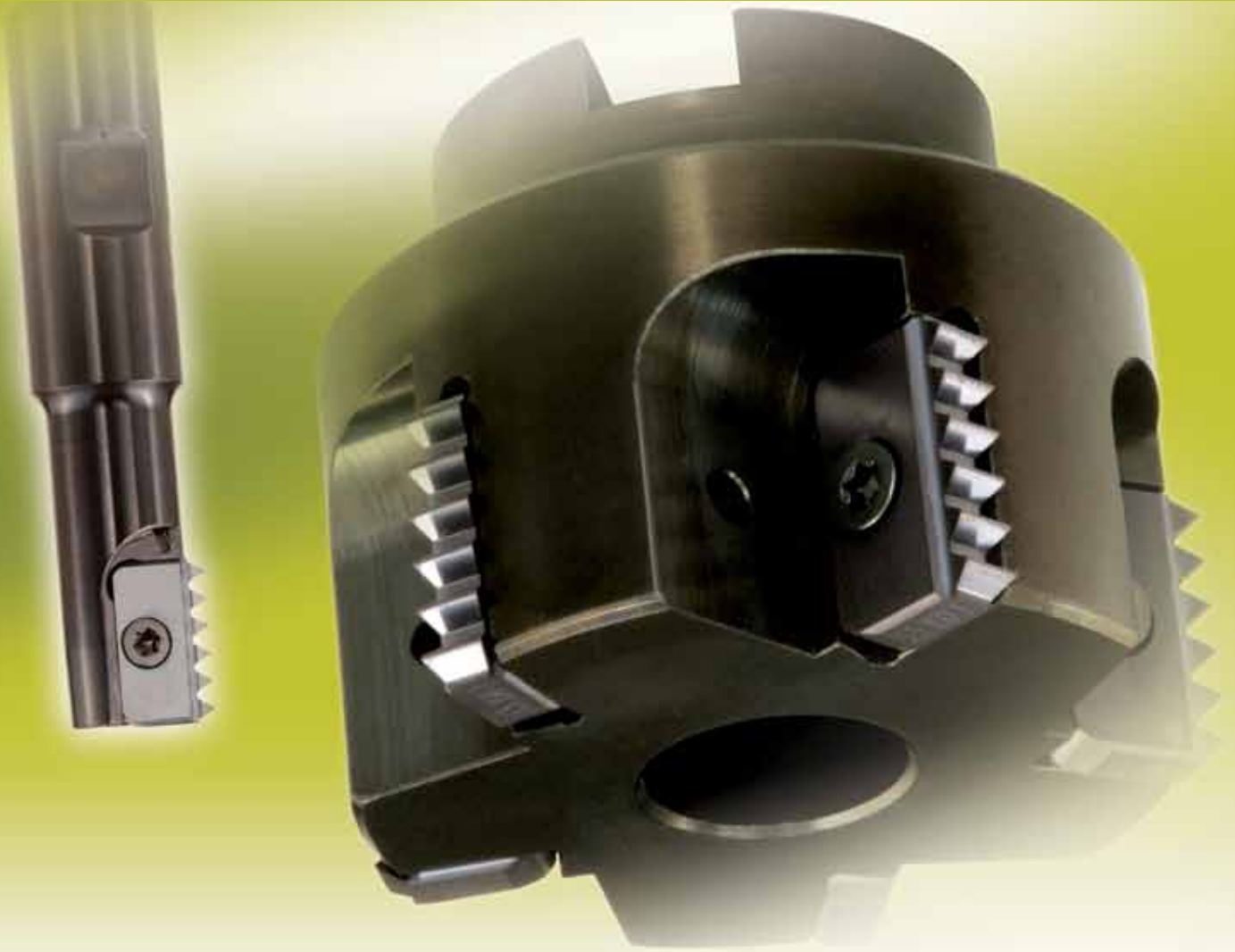

Contents:

Page:

Product Identification	184
Single Insert Toolholders	185
Long Shank Toolholders	186
Twin Insert Toolholders	186
Multi Insert Toolholders	187
External Multi Insert Toolholders	187
Long Carbide Shank Toolholders	188
Carbide Shank Toolholders for Single	188

Product Identification

Mill-Thread Toolholders Ordering Codes

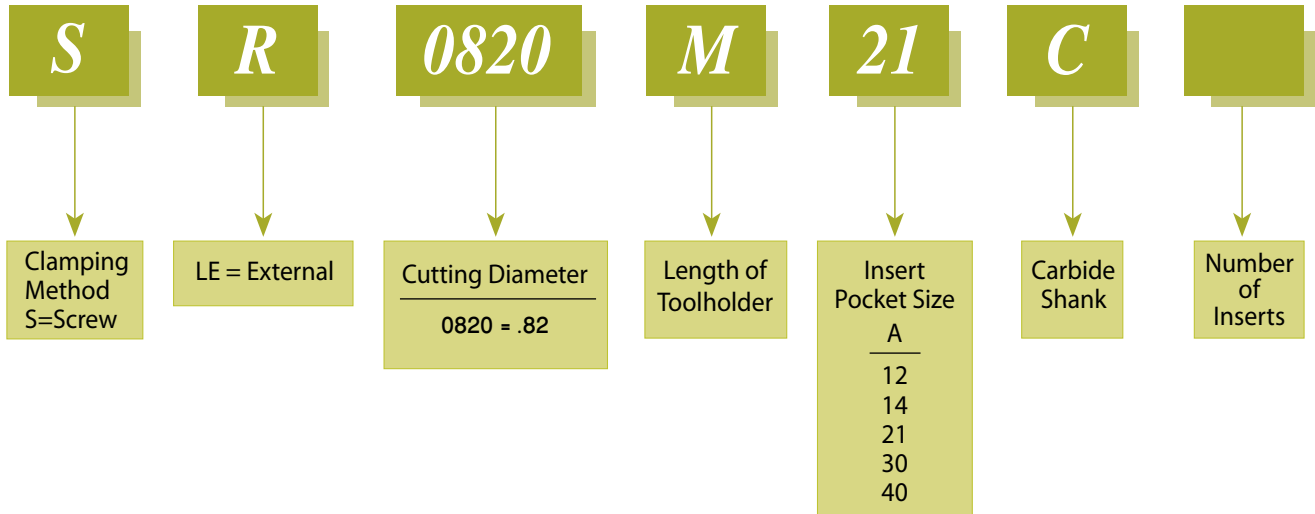

Single Insert Toolholders

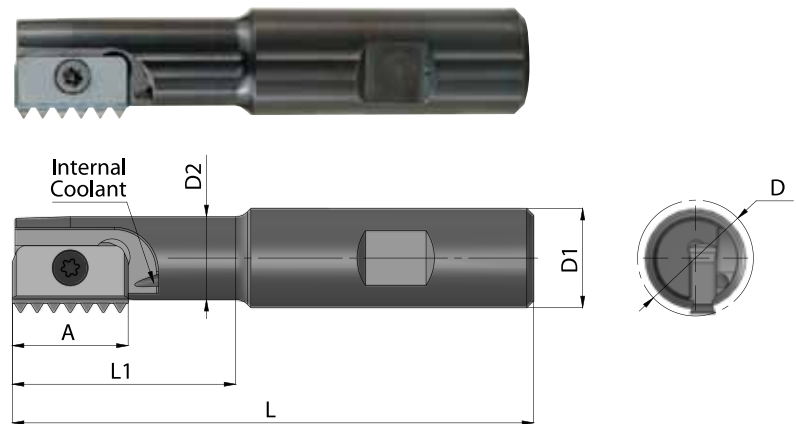

Ordering Code	A mm	D	D1	D2	L	L1	Insert Screw	Torx Key
SR0375H12	12	.37	.75	.30	3.35	.51	S12	K12
* SR0390H12	12	.39	.75	.30	3.35	.51	S12	K12
SR0500F14	14	.50	.75	.37	2.95	.70	S14	K14
SR0540F14	14	.54	.75	.38	2.98	.77	S14	K14
SR0570H14	14	.57	.75	.41	3.20	1.00	S14	K14
SR0670H14	14	.67	.75	.53	3.35	1.18	S14	K14
SR0790H21	21	.79	.75	.61	3.70	1.57	S21	K21
SR0790K21	21	.79	.75	.61	5.00	2.25	S21	K21
SR1140J30	30	1.14	1.00	.88	4.27	1.85	S30	K30
SR1500P40	40	1.50	1.25	1.13	7.00	4.25	S40	K40
SR1500R40	40	1.50	1.25	1.13	8.00	5.25	S40	K40
SR1730M40	40	1.73	1.50	1.38	6.02	3.19	S40	K40

Order example: SR0790H21

* For conical inserts: 12-18 NPT, 12-18 NPTF, 12-19 BSPT

Long Shank Toolholders

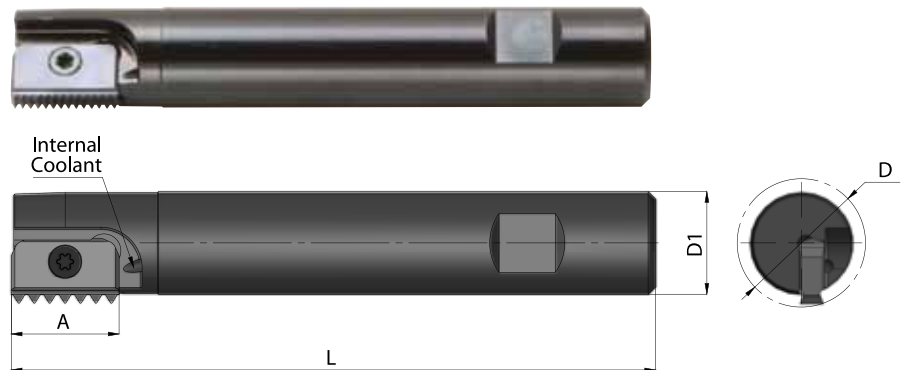

Ordering Code	A mm	D	D1	L	Insert Screw	Torx Key
SR0940K21	21	.94	.75	5.00	S21	K21
SR1240M30	30	1.24	1.00	6.00	S30	K30
SR1500M30	30	1.50	1.25	6.00	S30	K30

Order example: SR1240M30

For holders with long overhang reduce the cutting speed and feed rate between 20% to 40% (depends on workpiece material, pitch and overhang)

Twin Insert Toolholders

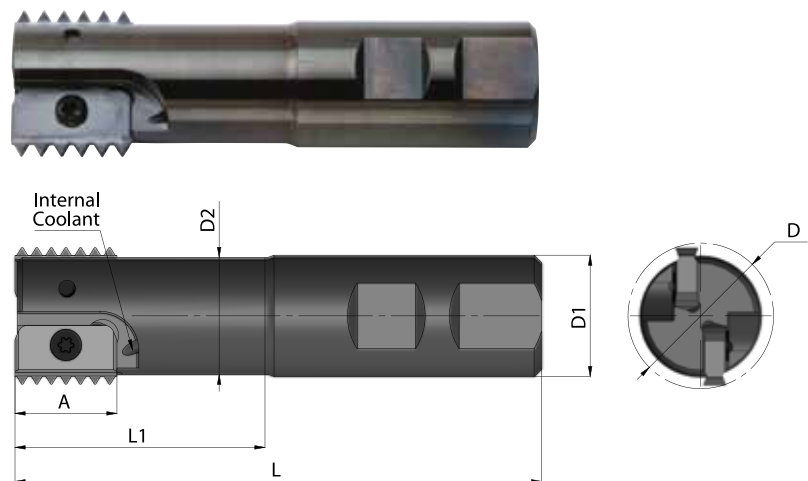

Ordering Code	A mm	D	D1	D2	L	L1	No. of Inserts	Insert Screw	Torx Key
SR0790H14-2	14	.79	.75	.63	3.66	1.54	2	S14	K14
SR1180J21-2	21	1.18	1.00	.95	4.25	1.97	2	S21	K21
SR1580L30-2	30	1.57	1.25	1.18	5.12	2.80	2	S30	K30
SR1970M40-2	40	1.97	1.50	1.49	6.02	3.35	2	S40	K40

Order example: SR1580L30-2

Multi Insert Toolholders

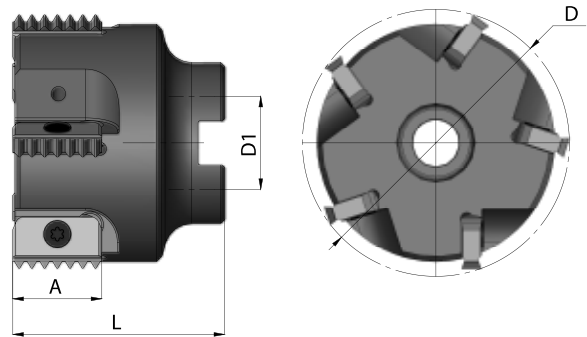

Ordering Code	A mm	D	D1	L	No. of Inserts	Insert Screw	Torx Key
SR2480C21-5	21	2.48	.75	1.97	5	S21	K21
SR2480C30-4	30	2.48	.75	1.97	4	S30	K30
SR3150D30-4	30	3.15	1.00	2.16	4	S30	K30
SR3940D30-4	30	3.94	1.25	2.36	4	S30	K30
SR3940D30-8	30	3.94	1.25	2.36	8	S30	K30
SR3150D40-4	40	3.15	1.00	2.56	4	S40	K40
SR3940E40-4	40	3.94	1.25	2.76	4	S40	K40
SR3940E40-6	40	3.94	1.25	2.76	6	S40	K40

Order example: SR3940D30-4

External Multi Insert Toolholder

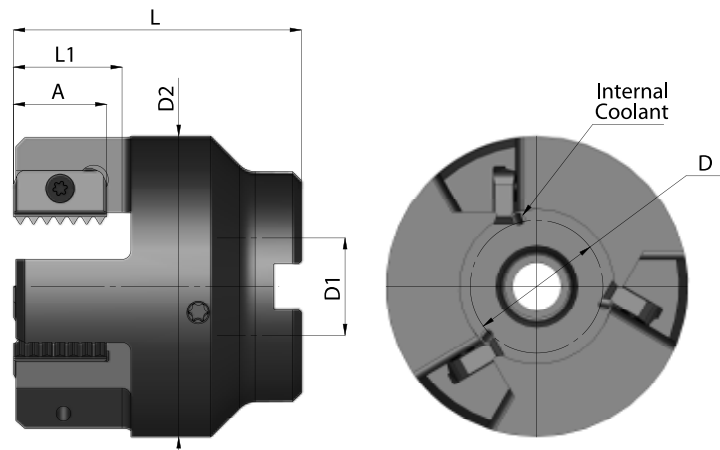

Ordering Code	A mm	D	D1	D2	L	L1	No. of Inserts	Insert Screw	Torx Key
SLE0790D21-3	21	.79	.75	2.28	2.56	.95	3	S21	K21
SLE1180D21-3	21	1.18	.75	2.68	2.56	.95	3	S21	K21
SLE1770E21-4	21	1.77	1.00	3.27	2.76	.95	4	S21	K21

Order example: SLE1180D21-3

Long Carbide Shank Toolholders

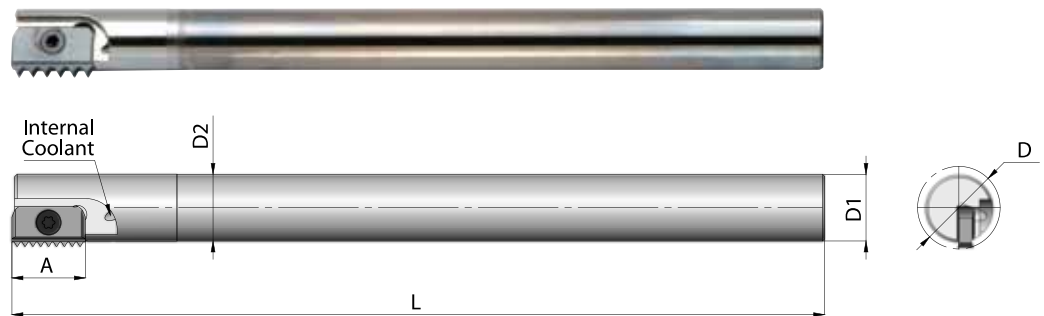

Ordering Code	A mm	D	D1	D2	L	Insert Screw	Torx Key
SR0390K12C	12	.39	.312	.312	5.0	S12	K12
SR0500J14C	14	.50	.375	.375	6.0	S14	K14
SR0620K14C	14	.62	.500	.500	7.0	S14	K14
SR0820M21C	21	.82	.625	.625	8.0	S21	K21
SR1020S30C	30	1.02	.750	.750	10.5	S30	K30

Order example: SR0620 K14C

For holders with long overhang reduce the cutting speed and feed rate between 20% to 40% (depends on workpiece material, pitch and overhang)

Carbide Shank Toolholders for Single Point Threading

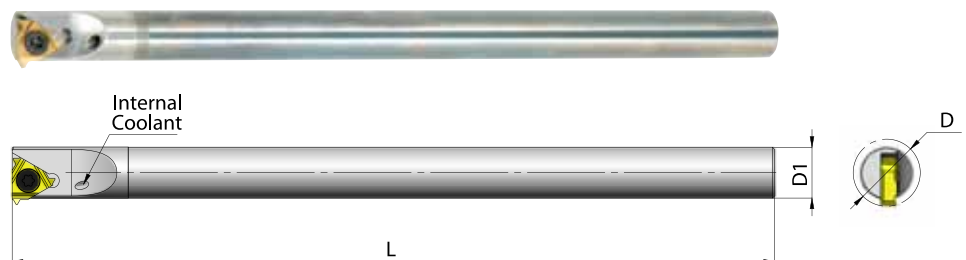

Ordering Code	L mm	Pitch Range		D	D1	L	Insert Screw	Torx Key
		mm	TPI					
* SR0250H08C	08	0.5-1.75	48-14	.35	.25	4.0	S08	K08
** SR0375M11C	11	0.5-2.00	48-11	.50	.38	6.0	S11	K11

For Inserts see the Thread Turning Tools section of this Catalogue

For an internal application use an internal R.H. insert.

* Without coolant bore

** For an external application use an external L.H. insert.

D-Thread



Mill-Thread Inserts & Toolholders for machining deep parts

- Improved productivity due to multi-insert toolholders.
- Partial Profile, standard or U-type inserts for a wide range of threads.
- Inserts with three cutting edges, reduces tooling costs.
- Low cutting resistance due to the single point inserts.
- Holder allows for a long overhang and includes internal coolant.
- Same insert and toolholder for both external and internal thread.

Contents:

Page:

Standard Toolholders and Inserts
U-Type Toolholders and Inserts

190
191-192

D-Thread Mill-Thread Inserts & Toolholders for machining deep threads

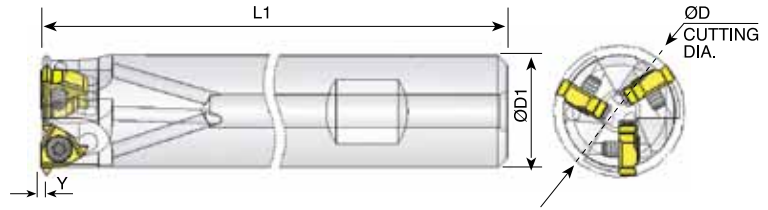

Ordering Code	Insert Size		Y	D	D1	L1	No. of Inserts	Insert Screw	Torx Key
	L mm	I.C							
SR0925Q11	11	1/4	.04	.925	.75	7.5	3	SE11	K11

Partial 60° Size 11

Ordering Code		Pitch Range	
		mm	TPI
1160D	INT.	1.0 - 2.0	24 - 12
	EX.	0.75 - 1.5	32 - 14

Partial 55° Size 11

Ordering Code		Pitch TPI
1155D	INT./EX.	24 - 14

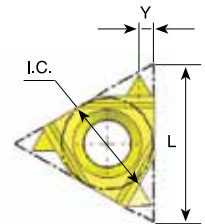

Coated Grade: BMA

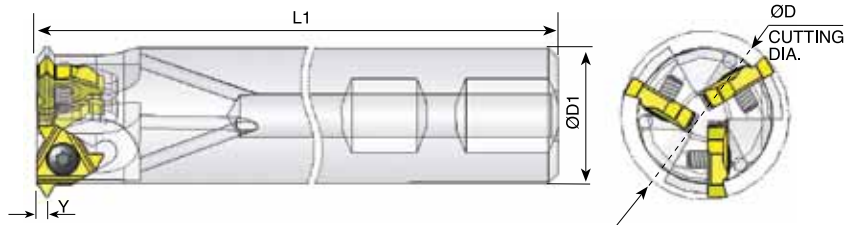

Ordering Code	Insert Size		Y	D	D1	L1	No. of Inserts	Insert Screw	Torx Key
	L mm	I.C							
SR1220R16	16	3/8	.07	1.22	1	8.86	3	SE16	K16

Partial 60° Size 16

Ordering Code		Pitch Range	
		mm	TPI
1660D	INT.	2.5 - 3.5	10 - 7
	EX.	2.0 - 3.0	12 - 8

Partial 55° Size 16

Ordering Code		Pitch TPI
1655D	INT./EX.	12 - 8

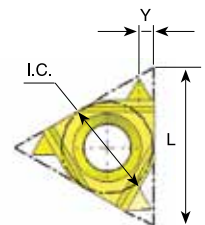

Coated Grade: BMA

D-Thread Mill-Thread Inserts & Toolholders for machining deep threads

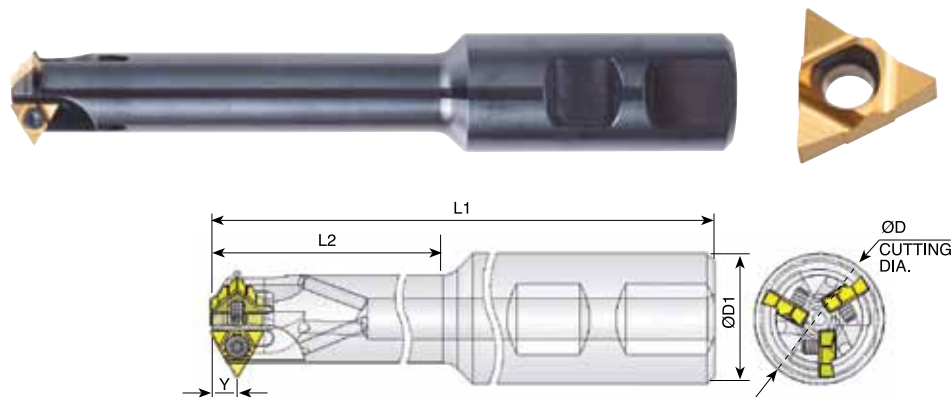

Ordering Code	Insert Size		Y	D	D1	L1	L2	No. of Inserts	Insert Screw	Torx Key
	L mm	I.C								
* SR0580M11U	11U	1/4U	.20	.580	.625	5.9	2.16	1	SE11	K11
** SR0810M11U	11U	1/4U	.20	.810	1	5.9	2.56	2	SE11	K11
SR0905M11U	11U	1/4U	.20	.905	1	5.9	3.46	3	SE11	K11

* Pitch limitations: for partial 60° - INT. - 10-9 TPI, EX. -12 - 10 TPI; for partial 55° - 12 - 9 TPI

** Pitch limitations: for partial 60° - INT. - 10-8 TPI, EX. -12 - 9 TPI; for partial 55° - 12 - 9 TPI

Partial 60° Size 11U

Ordering Code		Pitch Range	
		mm	TPI
11U60D	INT.	2.5 - 4.0	10 - 6
	EX.	2.0 - 3.0	12 - 8
11U60D-18-12	INT.	1.5 - 2.0	18 - 12
	EX.	1.25 - 1.75	20 - 14

Partial 55° Size 11U

Ordering Code		Pitch TPI
11U55D	INT./EX.	12 - 7

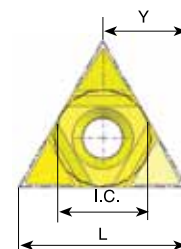

Coated Grade: BMA

D-Thread Mill-Thread Inserts & Toolholders for machining deep threads

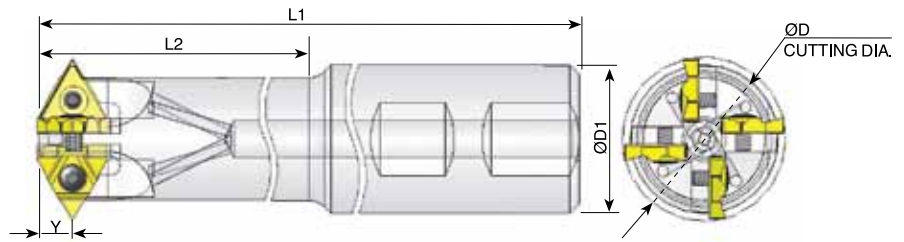

Ordering Code	Insert Size		Y	D	D1	L1	L2	No. of Inserts	Insert Screw	Torx Key
	L mm	I.C								
SR1400R16U	16U	3/8U	.30	1.40	1.25	8.66	6.1	4	SE16	K16

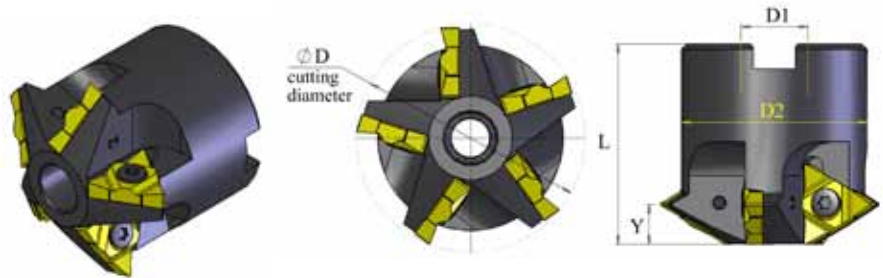

Ordering Code	Insert Size		Y	D	D1	D2	L	No. of Inserts	Insert Screw	Torx Key
	L mm	I.C								
SR1710B16U - 5	16U	3/8U	.30	1.71	0.5	1.39	1.5	5	SE16	K16

Partial 60° Size 16U

Ordering Code		Pitch Range	
		mm	TPI
16U60D	INT.	4.0 - 6.0	6 - 4
	EX.	3.0 - 5.0	8 - 5
16U60D-16-8	INT.	1.5 - 3.0	16 - 8
	EX.	1.5 - 2.5	18 - 10

Partial 55° Size 16U

Ordering Code		Pitch TPI
16U55D	INT./EX.	6 - 4.5

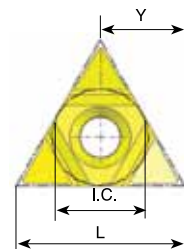

Coated Grade: BMA

Spiral Mill-Thread



Advantages of Spiral Mill-Thread Tools

- The spiral designed tools enable a smooth cutting operation at a high feed rate and reduced machining time.
- The tools suit a wide range of applications, from machining small components in small machining centers to heavy-duty applications in high power milling machines.
- Spiral fluted toolholders hold 2 to 9 inserts in a comparatively small cutting diameter.
- The unique clamping method enables optimal indexability.
- Spiral tools reduce vibration and chatter.
- High grade finish is achieved in all applications: threading, end milling roughing and finishing.
- Inserts are available in MT7 Sub-Micron Grade with Titanium Aluminum Nitride multi-layer coating (ISO K10 - K20). This is a general purpose grade, which can be used with all materials.

Contents:

Page:

Product Identification	194
ISO	195
UN	196-197
Whitworth	197
BSPT	198
NPT	198

Contents:

Page:

NPTF	199
NPS	199
Spiral Finishing Inserts	200
Toolholders	201-202
Special Tools	203
Case Studies	204

Product Identification - Ordering Codes

Spiral Mill - Thread Inserts

Inserts

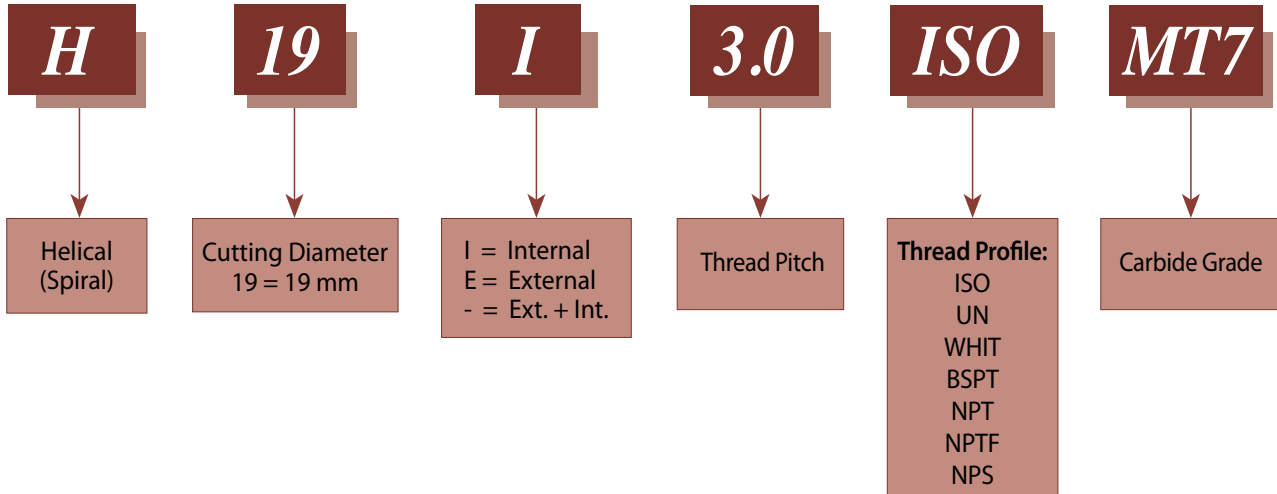

Toolholders

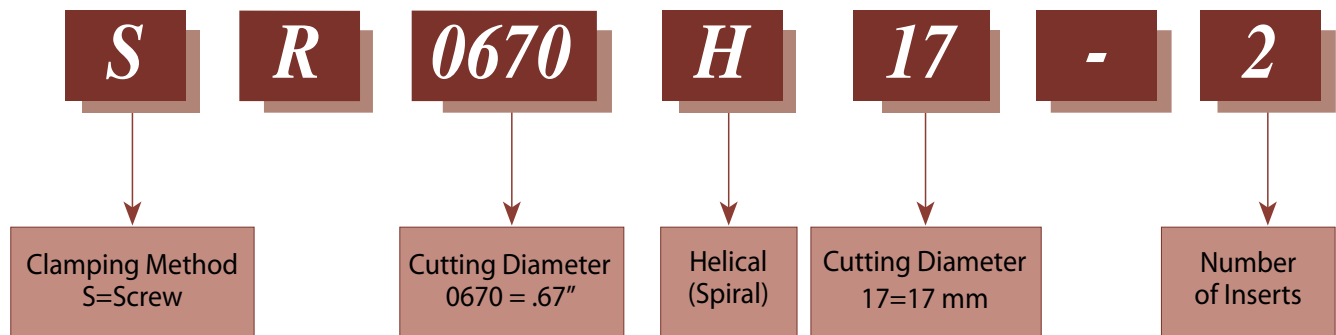

ISO

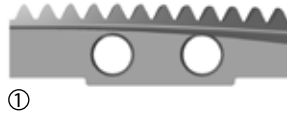
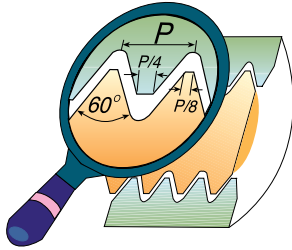

Insert Size	Fig.	Pitch mm	Ext./ Int.	M coarse	M fine	Ordering code	Toolholder
H13	1	1.0	Int.		≥ 15	H13 I 1.0 ISO	SR0510H13...
		1.5	Int.		≥ 16	H13 I 1.5 ISO	
		2.0	Int.	M16	≥ 17	H13 I 2.0 ISO	
H15	1	1.0	Int.		≥ 17	H15 I 1.0 ISO	SR0590H15...
		1.5	Int.		≥ 18	H15 I 1.5 ISO	
		2.0	Int.		≥ 19	H15 I 2.0 ISO	
H17	1	2.5	Int.	M18	≥ 20	H15 I 2.5 ISO	SR0670H17...
		1.0	Int.		≥ 19	H17 I 1.0 ISO	
		1.5	Int.		≥ 20	H17 I 1.5 ISO	
H19	1	2.0	Int.		≥ 21	H17 I 2.0 ISO	SR0750H19...
		2.5	Int.	M20, M22	≥ 22	H17 I 2.5 ISO	
		3.0	Int.		≥ 23	H19 I 2.0 ISO	
H23	2	3.0	Int.	M24, M27	≥ 25	H19 I 3.0 ISO	SR091H23...
		1.0	Ext.		≥ 25	H23 E 1.0 ISO	
		1.0	Int.		≥ 26	H23 I 1.0 ISO	
		1.5	Ext.		≥ 26	H23 E 1.5 ISO	
		1.5	Int.		≥ 27	H23 I 1.5 ISO	
		2.0	Ext.		≥ 27	H23 E 2.0 ISO	
		2.0	Int.		≥ 29	H23 I 2.0 ISO	
		3.0	Ext.		≥ 30	H23 E 3.0 ISO	
H32	2	3.0	Int.	M30, M33	≥ 31	H23 I 3.0 ISO	SR126H32...
		3.5	Int.		≥ 31	H23 I 3.5 ISO	
		4.0	Int.	M36	≥ 34	H23 I 4.0 ISO	
		1.0	Int.		≥ 34	H32 I 1.0 ISO	
		1.5	Ext.		≥ 35	H32 E 1.5 ISO	
		1.5	Int.		≥ 35	H32 I 1.5 ISO	
		2.0	Ext.		≥ 36	H32 E 2.0 ISO	
		2.0	Int.		≥ 36	H32 I 2.0 ISO	
H45	2	3.0	Ext.		≥ 38	H32 E 3.0 ISO	SR177H45...
		3.0	Int.		≥ 38	H32 I 3.0 ISO	
		3.5	Int.		≥ 39	H32 I 3.5 ISO	
		4.0	Ext.		≥ 39	H32 E 4.0 ISO	
		4.0	Int.	M39	≥ 40	H32 I 4.0 ISO	
		4.5	Int.	M42, M45	≥ 41	H32 I 4.5 ISO	
		5.0	Int.	M48	≥ 42	H32 I 5.0 ISO	
		1.5	Ext.		≥ 48	H45 E 1.5 ISO	
H63	2	1.5	Int.		≥ 48	H45 I 1.5 ISO	SR248H63...
		2.0	Ext.		≥ 49	H45 E 2.0 ISO	
		2.0	Int.		≥ 49	H45 I 2.0 ISO	
		3.0	Int.		≥ 51	H45 I 3.0 ISO	
		3.5	Int.		≥ 52	H45 I 3.5 ISO	
		4.0	Int.		≥ 53	H45 I 4.0 ISO	
		4.5	Int.		≥ 54	H45 I 4.5 ISO	
		5.0	Int.	M52	≥ 55	H45 I 5.0 ISO	
H63	2	5.5	Int.	M56, M60	≥ 56	H45 I 5.5 ISO	SR248H63...
		6.0	Int.	M64, M68	≥ 57	H45 I 6.0 ISO	
		1.5	Int.		≥ 66	H63 I 1.5 ISO	
		2.0	Int.		≥ 67	H63 I 2.0 ISO	
		3.0	Int.		≥ 69	H63 I 3.0 ISO	
H63	2	4.0	Int.		≥ 71	H63 I 4.0 ISO	SR248H63...
		6.0	Int.		≥ 75	H63 I 6.0 ISO	

UN

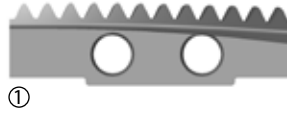
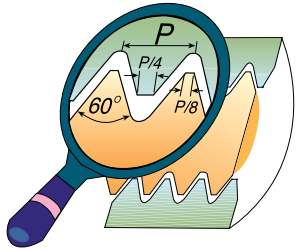

Insert Size	Fig.	Pitch TPI	Ext./ Int.	UN	UNC	UNF	UNS	Ordering code	Toolholder	
H13	1	16	Int.	5/8, 11/16				H13 I 16 UN	SR0510H13...	
		14	Int.				5/8	H13 I 14 UN		
		12	Int.	11/16				H13 I 12 UN		
H15	1	16	Int.			3/4		H15 I 16 UN	SR0590H15...	
		14	Int.				3/4	H15 I 14 UN		
		12	Int.	3/4, 13/16				H15 I 12 UN		
		10	Int.		3/4		7/8, 1	H15 I 10 UN		
H17	1	16	Int.	13/16 - 1				H17 I 16 UN	SR0670H17...	
		14	Int.			7/8, 1		H17 I 14 UN		
		12	Int.	7/8				H17 I 12 UN		
		9	Int.		7/8			H17 I 9 UN		
H19	1	12	Int.	15/16		1		H19 I 12 UN	SR0750H19...	
		8	Int.	1 1/16, 1 1/8	1			H19 I 8 UN		
H23	2	32	Int.	1			1 - 1 1/4	H23 I 32 UN	SR091H23...	
		24	Int.					H23 I 24 UN		
		20	Ext.					H23 E 20 UN		
		20	Int.	1 1/16 - 1 5/16						H23 I 20 UN
		18	Ext.					H23 E 18 UN		
		18	Int.				1	H23 I 18 UN		
		16	Ext.					H23 E 16 UN		
		16	Int.	1 1/16 - 1 5/16						H23 I 16 UN
		14	Ext.					H23 E 14 UN		
		14	Int.				≥1 1/8	H23 I 14 UN		
		12	Ext.					H23 E 12 UN		
		12	Int.	1 1/16 - 1 3/16		1 1/8				H23 I 12 UN
		10	Ext.					H23 E 10 UN		
		10	Int.				≥1 1/8	H23 I 10 UN		
8	Ext.					H23 E 8 UN				
8	Int.	1 3/16 - 1 5/16					H23 I 8 UN			
7	Ext.					H23 E 7 UN				
7	Int.			1 1/4			H23 I 7 UN			
H28	2	12	Int.	1 5/16		1 1/4, 1 3/8		H28 I 12 UN	SR110H28...	
		8	Int.	1 3/8 - 1 7/16				H28 I 8 UN		
		6	Int.	1 3/8 - 1 9/16	1 1/2			H28 I 6 UN		
H32	2	24	Ext.				≥1 3/8	H32 E 24 UN	SR126H32...	
		20	Ext.					H32 E 20 UN		
		20	Int.	≥1 3/8				H32 I 20 UN		
		18	Ext.					H32 E 18 UN		
		18	Int.				≥1 3/4	H32 I 18 UN		
		16	Ext.					H32 E 16 UN		
		16	Int.	1 3/8 - 1 7/8				H32 I 16 UN		
		12	Ext.					H32 E 12 UN		
		12	Int.	1 7/16 - 1 7/8		1 1/2		H32 I 12 UN		
		8	Ext.					H32 E 8 UN		
8	Int.	1 1/2 - 2				H32 I 8 UN				
6	Ext.					H32 E 6 UN				
6	Int.	1 5/8 - 1 7/8				H32 I 6 UN				
5	Int.			1 3/4		H32 I 5 UN				
H40	2	6	Int.	1 15/16, 2				H40 I 6 UN	SR157H40...	
		4.5	Int.		2			H40 I 4.5 UN		

UN

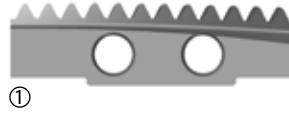
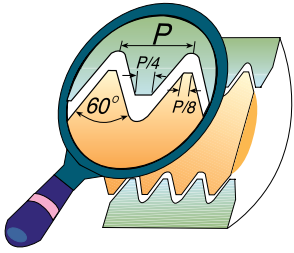

Insert Size	Fig.	Pitch TPI	Ext./ Int.	UN	UNC	UNF	UNS	Ordering code	Toolholder
H45	2	16	Int.	1 15/16 - 2 1/2			2 1/16 - 2	H45 I 16 UN	SR177H45...
		12	Int.	1 15/16 - 2 5/8				H45 I 12 UN	
		8	Int.	2 1/8 - 2 5/8				H45 I 8 UN	
		6	Int.	2 1/8 - 2 3/4				H45 I 6 UN	
		4.5	Int.		2 1/4			H45 I 4.5 UN	
		4	Int.		2 1/2 - 2 3/4		H45 I 4 UN		
H63	2	16	Int.	≥ 2 5/8				H63 I 16 UN	SR248H63...
		12	Int.	≥ 2 3/4				H63 I 12 UN	
		8	Int.	≥ 2 3/4				H63 I 8 UN	
		6	Int.	≥ 2 7/8				H63 I 6 UN	
		4	Int.		≥ 3			H63 I 4 UN	

Whitworth

Same insert for internal and external thread

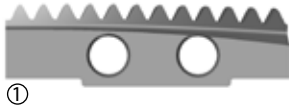
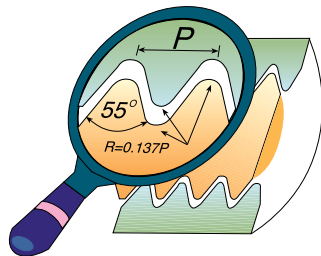

Insert Size	Fig.	Pitch TPI	Ordering code	Thread Size	Toolholder
H13	1	19	H13- 19 W	G 3/8	SR0510H13...
H15	1	14	H15- 14 W	G 1/2	SR0590H15...
H17	1	14	H17- 14 W	G 1/2 - 5/8	SR0670H17...
		11	H17- 11 W	G ≥ 1"	
H19	1	14	H19- 14 W	G 3/4 - 7/8	SR0750H19...
		11	H19- 11 W	G ≥ 1"	
H23	2	14	H23-14 W	Int. G 7/8" Ext. ≥ G 1/2"	SR091H23...
		11	H23-11 W	≥ G1"	
H32	2	14	H32-14 W	Ext. ≥ G 1/2"	SR126H32...
		11	H32-11 W	Int. ≥ G 1 1/8" Ext. ≥ G 1"	
H45	2	11	H45-11 W	Int. ≥ G 1 5/8" Ext. ≥ G 1"	SR177H45...
H63	2	11	H63-11 W	Int. ≥ G 2 3/8" Ext. ≥ G 1"	SR248H63...

BSPT

Same insert for internal and external thread

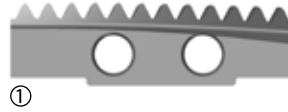
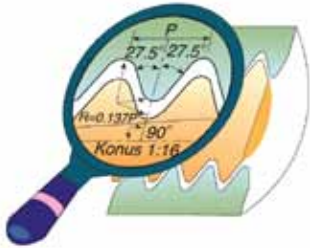

Insert Size	Fig.	Pitch TPI	Ordering code	Thread Size	Toolholder
H13	1	19	H13-19 BSPT	3/8	SR0510H13...
H15	1	14	H15-14 BSPT	1/2 - 3/4	SR0590H15...
H17	1	14	H17-14 BSPT	1/2 - 3/4	SR0670H17...
H23	2	11	H23-11 BSPT	≥ 1"	SR091H23...
H32	2	11	H32-11 BSPT	Int. ≥ 1 1/8" Ext. ≥ 1"	SR126H32...
H45	2	11	H45-11 BSPT	Int. ≥ 1 3/4" Ext. ≥ 1"	SR177H45...
H63	2	11	H63-11 BSPT	Int. ≥ 2 1/2" Ext. ≥ 1"	SR248H63...

NPT

Same insert for internal and external thread

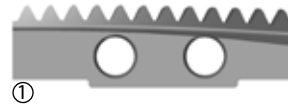
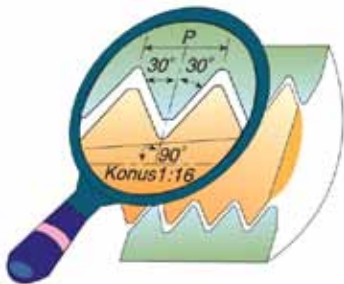

Insert Size	Fig.	Pitch TPI	Ordering code	Thread Size	Toolholder
H13	1	18	H13-18 NPT	3/8	SR0510H13...
H15	1	14	H15-14 NPT	1/2 - 3/4	SR0590H15...
H17	1	14	H17-14 NPT	1/2 - 3/4	SR0670H17...
H23	2	11.5	H23-11.5 NPT	1"-2"	SR091H23...
H32	2	11.5	H32-11.5 NPT	Int. 1 1/4"-2" Ext. 1"-2"	SR126H32...
H45	2	11.5	H45-11.5 NPT	Int. ≥ 1 5/8" Ext. ≥ 1"	SR177H45...
		8	H45- 8 NPT	≥ 2 1/2"	
H63	2	11.5	H63-11.5 NPT	Ext. 1-2"	SR248H63...
		8	H63- 8 NPT	≥ 3"	

NPTF

Same insert for internal and external thread

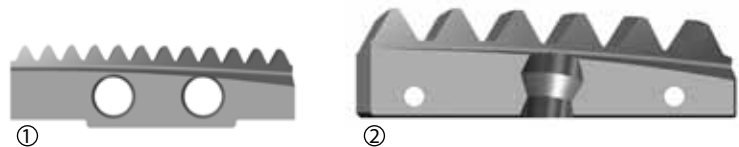
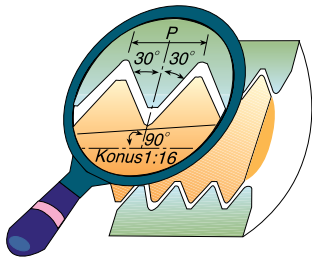

Insert Size	Fig.	Pitch TPI	Ordering code	Thread Size	Toolholder
H13	1	18	H13-18 NPTF	3/8	SR0510H13...
H15	1	14	H15-14 NPTF	1/2 - 3/4	SR0590H15...
H17	1	14	H17-14 NPTF	1/2 - 3/4	SR0670H17...
H23	2	11.5	H23-11.5 NPTF	1"-2"	SR091H23...
H32	2	11.5	H32-11.5 NPTF	Int. 1 1/4"-2" Ext. 1" -2"	SR126H32...

NPS

Same insert for internal and external thread



Insert Size	Pitch TPI	Thread	Ordering code	Toolholder
H13	18	3/8	H13- 18 NPS	SR0510H13...
H15	14	1/2 - 3/4	H15- 14 NPS	SR0590H15...
H17	14	1/2 - 3/4	H17- 14 NPS	SR0670H17...

Spiral Finishing Inserts

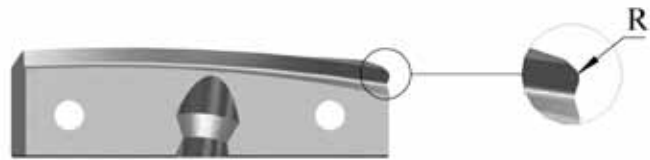

Insert Size	R	Ordering code	Toolholder
H23	0.2	H23 F R 0.2	SR091H23...
	0.5	H23 F R 0.5	
	1.0	H23 F R 1.0	
H32	0.2	H32 F R 0.2	SR126H32...
	0.5	H32 F R 0.5	
	1.0	H32 F R 1.0	
H45	0.2	H45 F R 0.2	SR177H45...
	0.5	H45 F R 0.5	
	1.0	H45 F R 1.0	
	1.5	H45 F R 1.5	
	2.0	H45 F R 2.0	
H63	0.2	H63 F R 0.2	SR248H63...
	0.5	H63 F R 0.5	
	1.0	H63 F R 1.0	
	1.5	H63 F R 1.5	
	2.0	H63 F R 2.0	

Toolholders

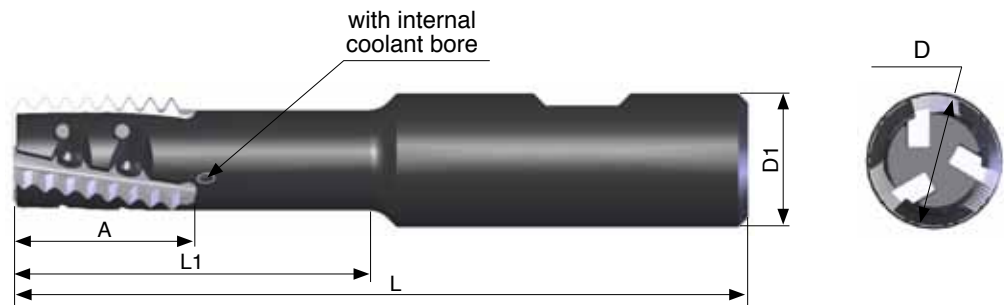

Ordering Code	Insert Type	Insert size A	D	D1	L	L1	No. of Inserts	Screw	Key
SR0510H13 -1	H13	1.06	.51	.75	3.54	1.38	1	S13	K16
SR0590H15 -1	H15	1.06	.59	.75	3.74	1.57	1	S15	K16
*SR0670H17 -2	H17	1.06	.67	.75	3.35	1.18	2	S17	K16
*SR0670H17J-2	H17	1.06	.67	.75	3.94	1.77	2	S17	K16
SR0750H19 -3	H19	1.06	.75	.75	3.35	1.18	3	S19	K16
SR0750H19J-3	H19	1.06	.75	.75	4.33	2.16	3	S19	K16

* When using NPT, NPTF, BSPT inserts the cutting diameter D = .71"

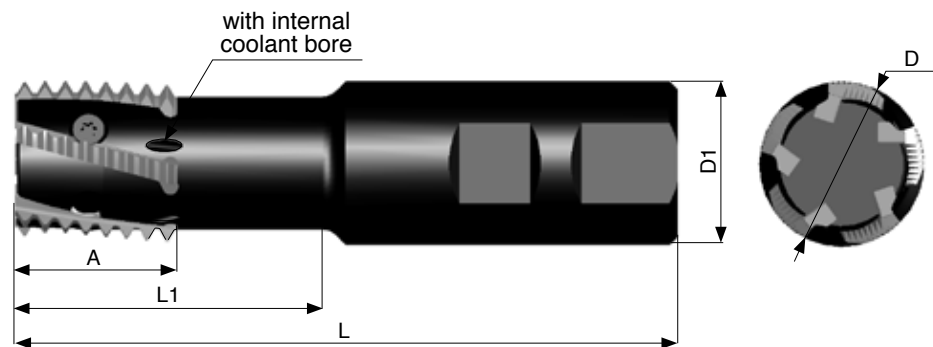

Ordering Code	Insert Type	Insert size A	D	D1	L	L1	No. of Inserts	Screw	Key
SR091H23 -2	H23	1.06	0.91	1.0	4.5	2.00	2	S23	K21
SR091H23M-2	H23	1.06	0.91	1.0	6.0	3.07	2	S23	K21
SR110H28 -3	H28	1.26	1.10	1.25	6.0	3.0	3	S32S	K22
SR126H32 -5	H32	1.26	1.26	1.25	5.0	2.36	5	S32	K22
SR126H32P-5	H32	1.26	1.26	1.25	7.0	3.58	5	S32	K22

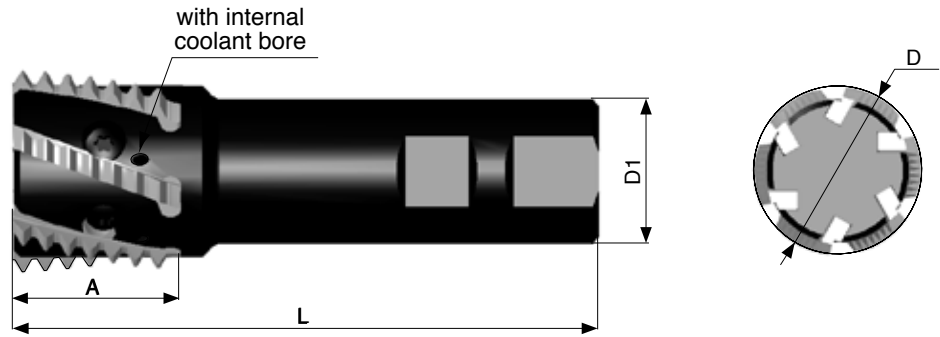

Ordering Code	Insert Type	Insert size A	D	D1	L	No. of Inserts	Screw	Key
SR157H40-4	H40	1.46	1.57	1.25	7.5	4	S45S	K40
SR177H45-6	H45	1.46	1.77	1.25	5.0	6	S45S	K40

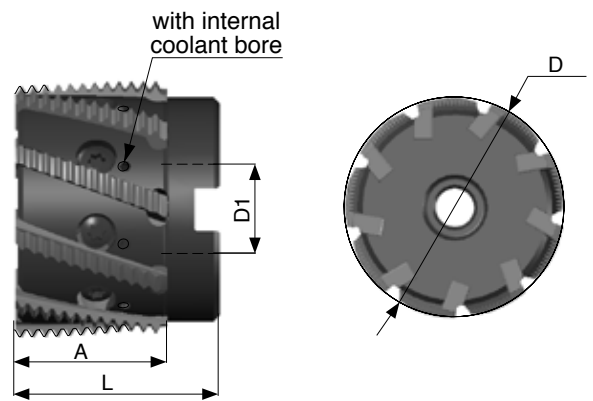

Ordering Code	Insert Type	Insert size A	D	D1	L	No. of Inserts	Screw	Key
SR126H32-5M	H32	1.26	1.26	0.50	2.05	5	S32S	K22
SR177H45-6M	H45	1.46	1.77	0.50	1.91	6	S45	K40
SR248H63-9	H63	1.5	2.48	0.75	2.00	9	S63	K40

Special Tools

In addition to standard products, Carmex manufactures special tools and inserts according to customers' requests. The toolholders are multi-purpose, making them suitable for both roughing and finishing inserts. Special tools are supplied in short delivery times.



Case Studies

Case Study no. 1

Thread	M56x1.5
Internal/External	Internal
Thread Length	1.3"
Raw Material	Ductile Iron
Cutting Speed – Vc	427 ft/min
Tooth Load – Fz	0.0059 inch/tooth
Toolholder	SR177H45-6
Insert	H45 I 1.5 ISO MT7
Result	600 pcs with 0.0008" offset (Competitor – 40 pcs with 0.0059 offset)



Case Study no. 2

Application	Grooves Milling
Internal/External	External
Raw Material	Cast Steel
Cutting Speed – Vc	640 ft/min
Tooth Load – Fz	0.0039 inch/tooth
Toolholder	SR248H63-9
Insert	Taylor Made H63
Result	1350 pcs (Competitor – 540 pcs)



Deep Reach Mill-Thread



Contents:

Page:

Toolholders
Extensions

206-208
208

Carmex presents a modular line of Mill-Thread toolholders

- Carmex modular holders are ideal for deep reach applications.
- Unique clamping method enables optimal strength and indexability.
- Cost saving - Same shank can hold different heads.
- Toolholders with internal coolant bore.
- Screw connection allows long overhang.
- Carmex standard thread milling inserts fit these toolholders.
- Different steel extensions are available.
- Toolholders are compatible with common toolholding systems.

Toolholders

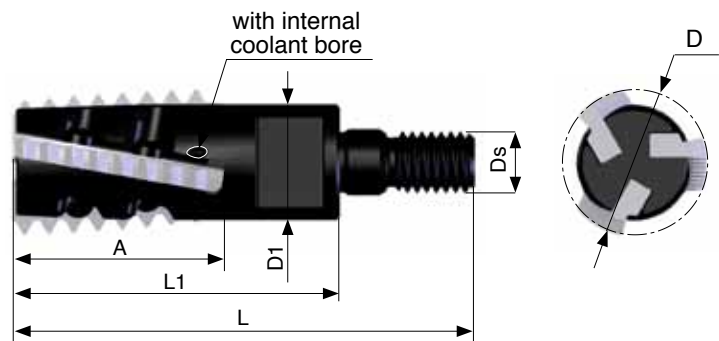

Ordering Code	Insert size A	D	D1	Ds	L1	L	No. of Inserts	Screw	Key
SR075H19 - 3 S	1.06	.75	.59	M8	1.67	2.36	3	S19	K16

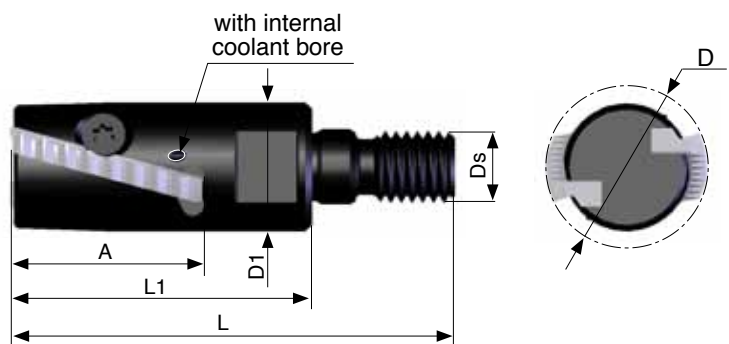

Ordering Code	Insert size A	D	D1	Ds	L1	L	No. of Inserts	Screw	Key
SR091H23 - 2 S	1.06	.91	.71	M10	1.67	2.46	2	S23	K16

Deep Reach Mill-Thread

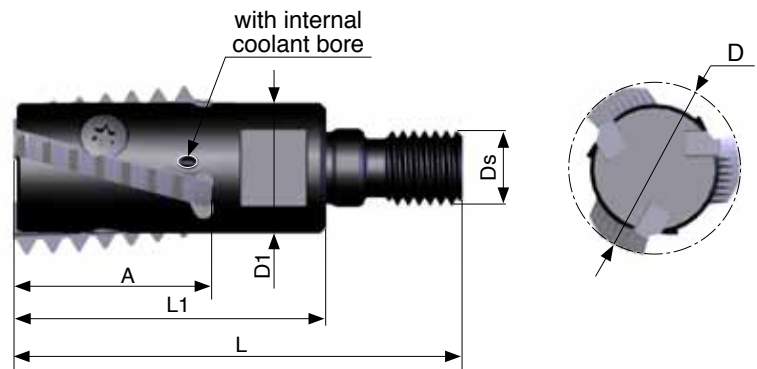

Ordering Code	Insert size A	D	D1	Ds	L1	L	No. of Inserts	Screw	Key
SR110H28 - 3 S	1.26	1.10	.83	M12	1.97	2.83	3	S28	K16

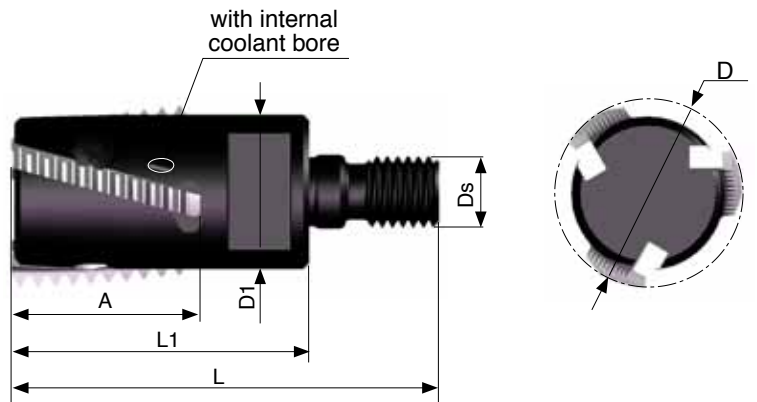

Ordering Code	Insert size A	D	D1	Ds	L1	L	No. of Inserts	Screw	Key
SR126H32 - 3 S	1.26	1.26	1.02	M12	1.97	2.83	3	S32S	K16

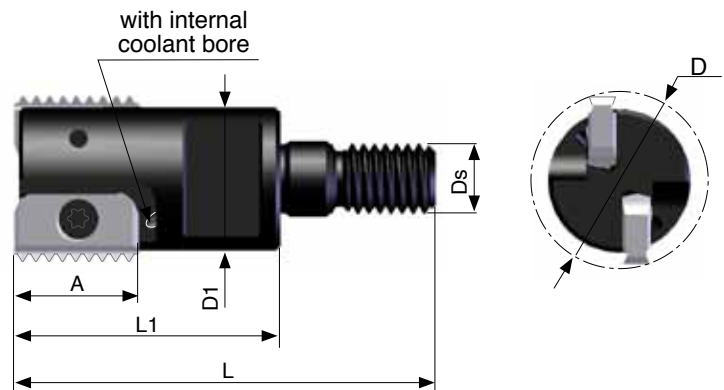

Ordering Code	Insert size A	D	D1	Ds	L1	L	No. of Inserts	Screw	Key
SR0790C14 - 2 S	.55	.79	.63	M8	1.20	1.89	2	S14	K14

Toolholders

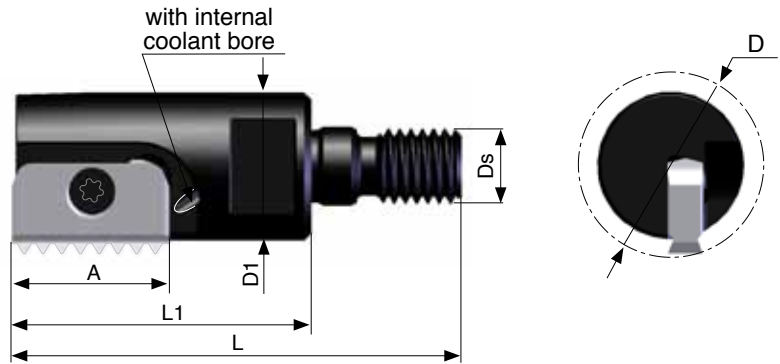

Ordering Code	Insert size A	D	D1	Ds	L1	L	No. of Inserts	Screw	Key
SR0980D21 - 1 S	.826	.98	.78	M10	1.57	2.36	1	S21	K21

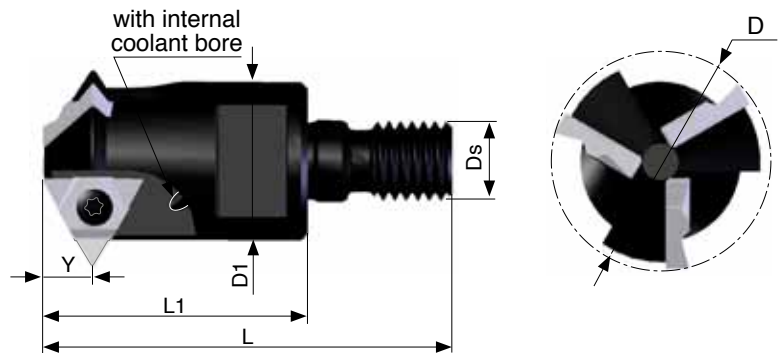

Ordering Code	Insert size		Y	D	D1	Ds	L1	L	No. of Inserts	Screw	Key
	L	I.C.									
SR1300D16U - 3 S	16U	3/8U	.30	1.30	.94	M12	1.57	2.44	3	S16S	K16

Extensions

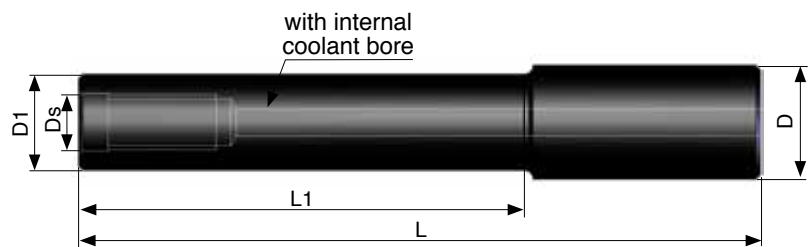

Ordering Code	D	D1	Ds	L	L1
E.625 M08 L3.15	.625	.59	M08	3.15	1.18
E.75 M10 L3.15	.75	.71	M10	3.15	1.18
E.75 M10 L5.0	.75	.71	M10	5.0	3.15
E1 M12 L4.0	1.0	.83	M12	4.0	2.0
E1 M12 L6.0	1.0	.83	M12	6.0	4.0

CMT Vertical Milling



Vertical milling indexable inserts and toolholders to perform a wide variety of threads, grooves, chamfers and more.

Advantages of CMT - Vertical Milling

- Ground profile inserts for high precision and excellent performance.
- Working at high machining parameters, with high surface quality.
- Solid and accurate clamping method enables full repeatability.
- Same insert for right-hand or left-hand threads.
- Toolholders include weldon shank and coolant bore.
- Chamfer inserts are also available.

Contents:

Page:

Product Identification	210-211
Partial Profile 60° - UN, ISO	212-213
Partial Profile 60° - NPT	213
Partial Profile 55° - BSW, BSF, BSP (G)	214
Full Profile - ISO	215-216
Full Profile - UN	217-218
G 55° - BSW, BSF, BSP (G)	218
Trapez - DIN 103	219
Acme	219
Round - DIN 405	219
Chamfering and Grooving	220
Chamfering, Grooving and Boring	220
Groove Milling	221-222

Contents:

Page:

Full Radius Groove Milling	223
Face Milling and Finishing	223
Corner Rounding	224
Steel Toolholders - with Coolant Bore	225
Carbide Shank Toolholders	226
CMT Multi insert Milling Cutters	227
Product Identification	228
Groove Milling	229
Groove Milling with Chamfer	230
Partial Profile 60° - ISO, UN	231
Toolholders	232
Mill Cutter - Disc Milling	233

Product Identification - Ordering Codes

CMT Straight Flute Inserts

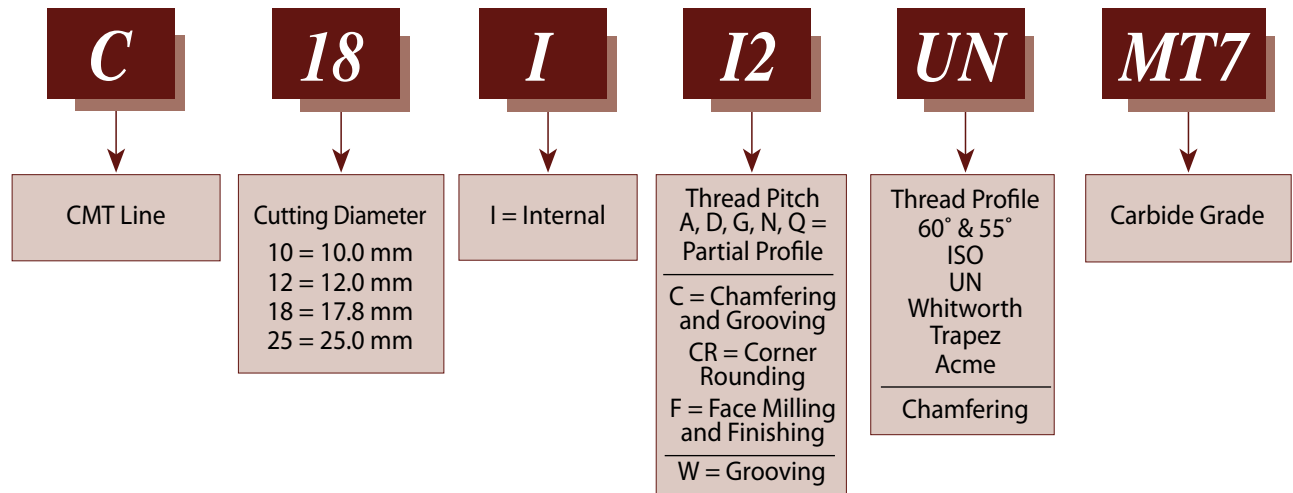
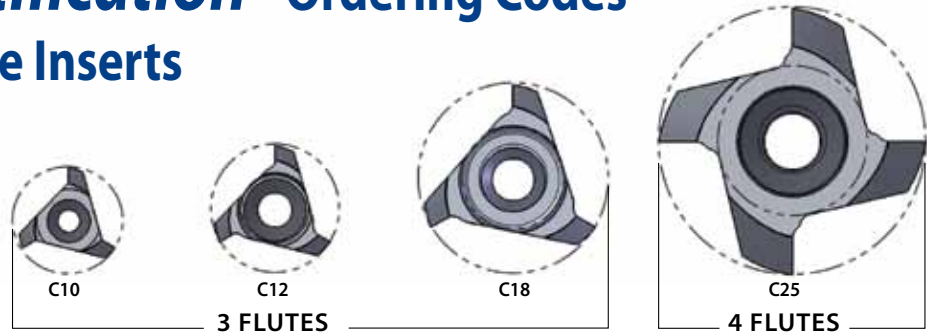

CMT Spiral Multi Flute Inserts

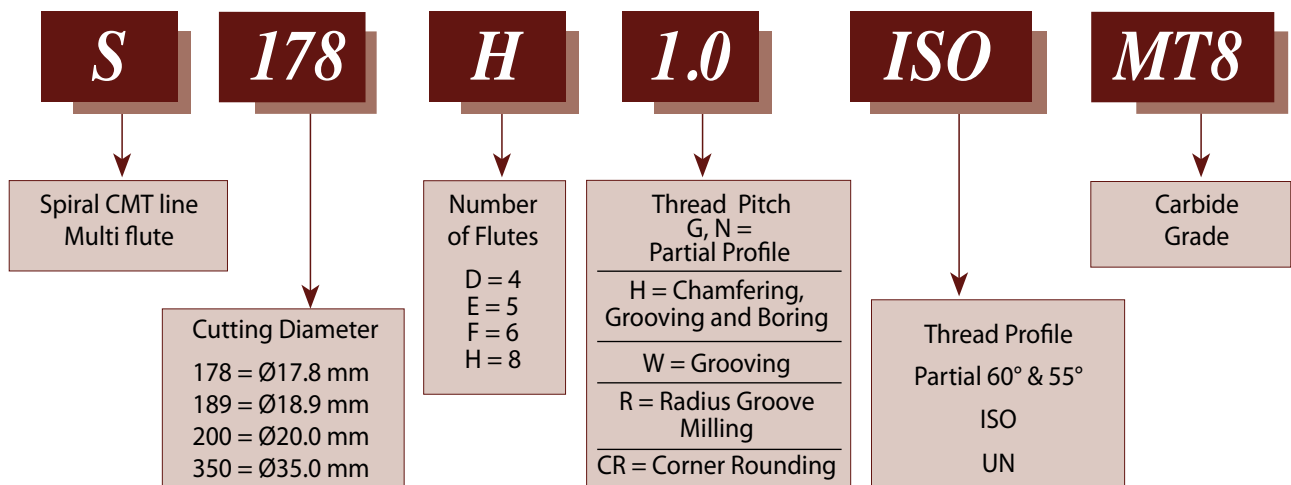
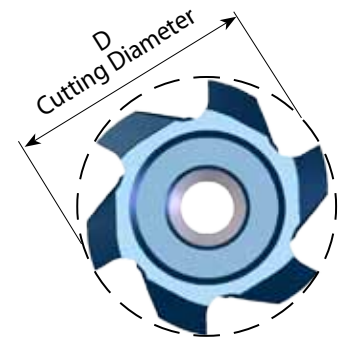

Product Identification - Ordering Codes CMT Toolholders

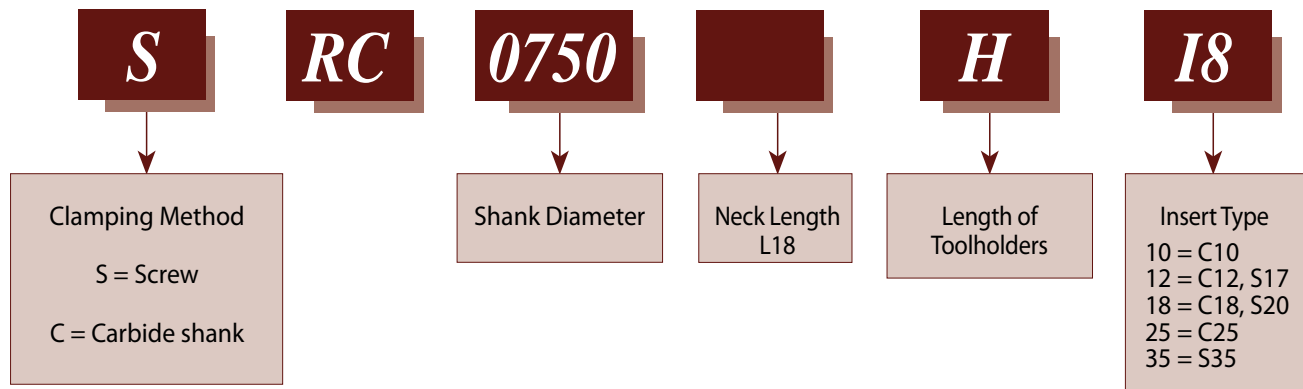

Partial Profile 60° - ISO, UN

Same insert for internal and external thread

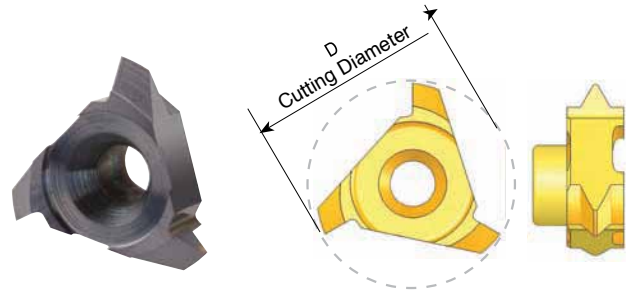

Insert Type	Pitch Range mm	Pitch Range TPI	Ordering Code	D	Thread Diameter (min)		Holder Code*
					Pitch Low Range	Pitch High Range	
C10	Int. 0.5 - 0.8	56 - 28	C10 A60	.39	$\phi \geq .43$	$\phi \geq .47$	H1, 2, 15, 16, 17
	Ex. 0.4 - 0.8	64 - 32		.39			
	Int. 1.0 - 2.0	28 - 13	C10 G60	.39	$\phi \geq .47$	$\phi \geq .55$	
	Ex. 0.8 - 1.75	32 - 15		.39			
C12	Int. 0.5 - 0.8	56 - 28	C12 A60	.47	$\phi \geq .51$	$\phi \geq .55$	H3, 4, 5, 18, 19, 20
	Ex. 0.4 - 0.8	64 - 32		.47			
	Int. 1.0 - 2.0	28 - 13	C12 G60	.49	$\phi \geq .55$	$\phi \geq .63$	
	Ex. 0.8 - 1.75	32 - 15		.49			
C18	Int. 0.5 - 0.8	56 - 28	C18 A60	.70	$\phi \geq .75$		H6, 7, 8, 9, 21, 22, 23
	Ex. 0.4 - 0.8	64 - 32		.70			
	Int. 1.0 - 1.75	28 - 14	C18 G60	.70	$\phi \geq .79$	$\phi \geq .83$	
	Ex. 0.8 - 1.5	32 - 16		.70			
	Int. 2.0 - 3.0	13 - 8	C18 D60	.70	$\phi \geq .83$	$\phi \geq .91$	
	Ex. 1.75 - 2.5	15 - 10		.70			
C25	Int. 1.5 - 2.5	16 - 10	C25 G60	.98	$\phi \geq 1.10$	$\phi \geq 1.18$	H10, 11, 24, 25
	Ex. 1.0 - 2.0	28 - 13		.98			
	Int. 3.0 - 5.0	8 - 5	C25 N60	.98	$\phi \geq 1.18$	$\phi \geq 1.34$	
	Ex. 2.5 - 4.5	10 - 6		.98			
	Int. 5.0 - 6.0	5 - 4	C25 Q60	.98	$\phi \geq 1.34$	$\phi \geq 1.38$	
	Ex. 4.5 - 5.0	6 - 5		.98			

* For complete toolholder description see pages 225-226.

Partial Profile 60° - ISO, UN

Same insert for internal and external thread

Multi Flute

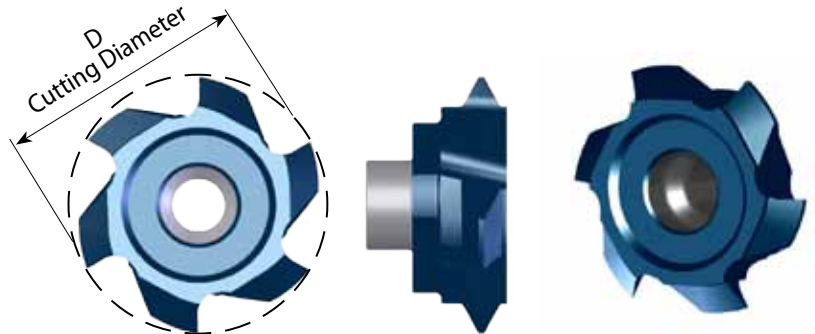

Insert Type	Ordering Code	Pitch Range mm	Pitch Range TPI	D	No. of Flutes	Thread Dia (min)		Holder Code*
						Pitch Low range	Pitch High range	
S20	S200 F G60	Int. 1.5-2.5	16-10	.79	6	Ø ≥ .91	Ø ≥ .98	H6, 7, 8, 9, 21, 22, 23
		Ex. 1.0-2.0	28-13	.79	6			
	S200 D N60	Int. 3.0-5.0	8-5	.79	4	Ø ≥ .98	Ø ≥ 1.14	
		Ex. 2.5-4.5	10-6	.79	4			

Partial Profile 60° - NPT

Same insert for internal and external thread

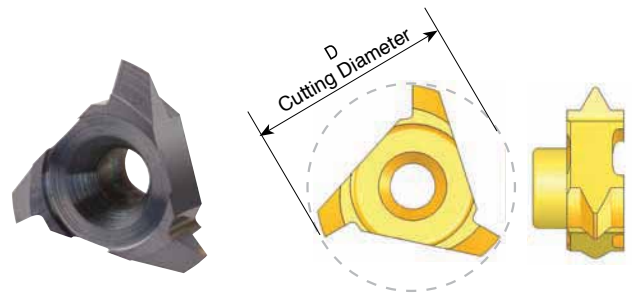

Insert Type	Pitch TPI	Standard	Ordering Code	D	Holder Code*
C10	18	1/4 - 3/8	C10 18 NPT	.39	H1, 2, 15, 17
C18	14	1/2 - 3/4	C18 14 NPT	.62	H21
C25	11.5	1-2	C25 11.5NPT	.98	H10, 11, 24, 25
	8	≥ 2 1/2	C25 8 NPT	.98	

* For complete toolholder description see pages 225-226.

Partial Profile 55° - BSP(G), BSF, BSW

Same insert for internal and external thread

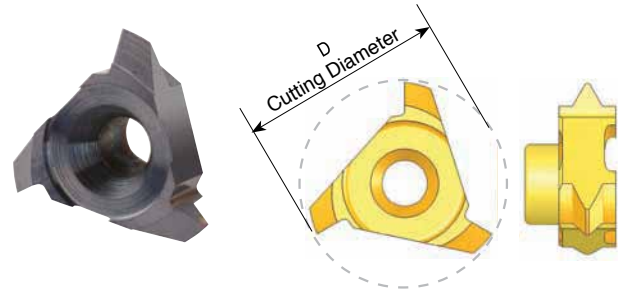

Insert Type	Pitch Range TPI	Ordering Code	D	Thread Dia. (min)	Holder Code*
C10	19-14	C10 G55	.39	$\phi \geq .51$	H1, 2, 15, 17
C12	28-19	C12 G55	.47	$\phi \geq .55$	H3, 4, 5, 18, 19, 20
	14- 11	C12 N55	.48	$\phi \geq .63$	H3, 4, 5, 18, 20
C18	14- 8	C18 G55	.71	$\phi \geq .91$	H6, 7, 8, 9, 21, 22, 23
C25	7- 5	C25 N55	.98	$\phi \geq 1.22$	H10, 11, 24, 25

Partial Profile 55° - BSP(G), BSF, BSW

Same insert for internal and external thread

Multi Flute

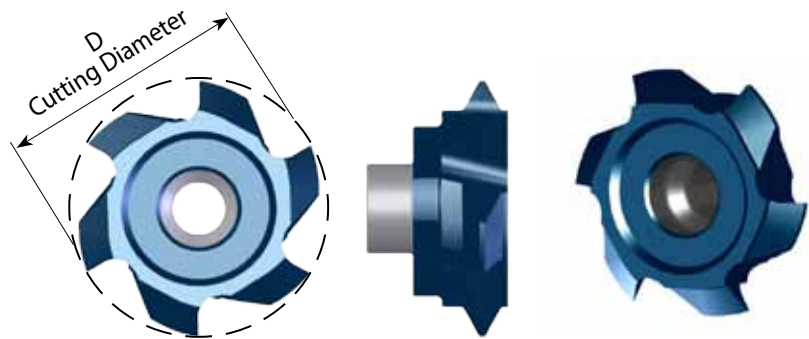

Insert Type	Ordering Code	Pitch Range TPI	D	No. of Flutes	Thread Dia (min)	Holder Code*
S17	S170 F G55	11-8	.67	6	$\phi \geq .73$	H3, 4, 5, 18, 19, 20
S20	S195 F G55	14	.77	6	$\phi \geq .91$	H6, 7, 8, 9, 21, 22, 23
	S200 D N55	8-6	.79	4	$\phi \geq .98$	H21

* For complete toolholder description see pages 225-226.

Full Profile - ISO

Inserts for internal thread

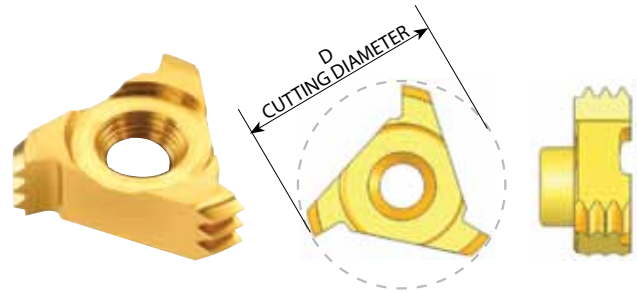

Insert Type	Pitch mm	M coarse	M fine	Ordering Code	Number of Teeth	D	Holder Code*
C10	0.5		M10, M12	C10 I 0.5 ISO	6	.35	H1,2,15,16, 17
	1.0		M12, M13	C10 I 1.0 ISO	3	.39	
	1.5		M13, M14	C10 I 1.5 ISO	2	.39	
	1.75	M12		C10 I 1.75ISO	1	.38	H1, 2, 15, 17
	2.0	M14	M18	C10 I 2.0 ISO	1	.39	
C12	0.5		M13-M18	C12 I 0.5 ISO	6	.47	H3,4,5,18,19,20
	0.75		M13-M18	C12 I 0.75ISO	4	.47	
	1.0		M14-M19	C12 I 1.0 ISO	3	.47	
	1.5		M15-M19	C12 I 1.5 ISO	2	.47	
	2.0	M16	M18, M20	C12 I 2.0 ISO	1	.49	
	2.5	M18, M20		C12 I 2.5 ISO	1	.47	H3, 4, 5,18, 20
3.0	M24		C12 I 3.0 ISO	1	.49		
C18	0.5		M19-M60	C18 I 0.5 ISO	9	.70	H6, 7, 8, 9, 21, 22, 23
	0.75		M19-M60	C18 I 0.75ISO	6	.70	
	1.0		M20-M60	C18 I 1.0 ISO	5	.70	
	1.5		M20-M60	C18 I 1.5 ISO	3	.70	
	2.0		M21-M60	C18 I 2.0 ISO	2	.70	
	2.5	M22		C18 I 2.5 ISO	2	.70	
	3.0	M24, M27	M28-M60	C18 I 3.0 ISO	1	.70	
	3.5	M30, M33		C18 I 3.5 ISO	1	.70	
C25	3.0	M32, M33	M30-M80	C25 I 3.0 ISO	2	.98	H10, 11, 24, 25
	4.0	M36, M39	M40-M80	C25 I 4.0 ISO	1	.98	
	4.5	M45		C25 I 4.5 ISO	1	.98	
	5.0	M48, M52		C25 I 5.0 ISO	1	.98	
	5.5	M60		C25 I 5.5 ISO	1	.98	
	6.0	M64, M68	M70-M80	C25 I 6.0 ISO	1	.98	

* For complete toolholder description see pages 225-226.

Full Profile - ISO

Inserts for internal thread

Multi Flute

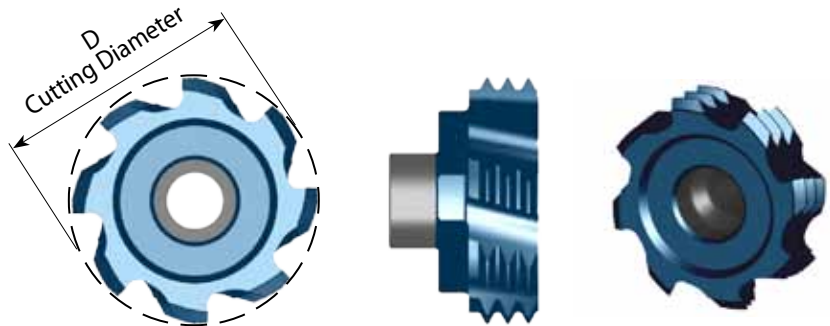

Insert Type	Ordering Code	Pitch mm	M coarse	M fine	Number of Teeth	D	No. of Flutes	Holder Code*
S17	S160 F 2.5 ISO	2.5	M20		1	.63	6	H3, 4, 5, 18, 19, 20
S20	S163 H 1.0 ISO	1.0		M18-M60	5	.64	8	H6, 7, 8, 9, 21, 22, 23
	S175 H 1.5 ISO	1.5		M20-M60	3	.69	8	
	S186 F 2.0 ISO	2.0		M22-M60	2	.73	6	
	S178 F 2.5 ISO	2.5	M22		2	.70	6	
	S189 F 3.0 ISO	3.0	M24, M27	M28-M60	1	.74	6	
	S200 F 3.5 ISO	3.5	M30, M33		1	.79	6	
	S200 F 4.0 ISO	4.0	M36, M39	M40-M60	1	.79	6	
	S200 E 4.5 ISO	4.5	M42, M45		1	.79	5	
	S200 D 5.0 ISO	5.0	M48, M52		1	.79	4	H21
S35	S350 F 6.0 ISO	6.0	M64, M68		1	1.38	6	H12, 13, 14, 26
	S350 F 8.0 ISO	8.0		M130-M200	1	1.38	6	

* For complete toolholder description see pages 225-226.

Full Profile - UN

Inserts for internal thread

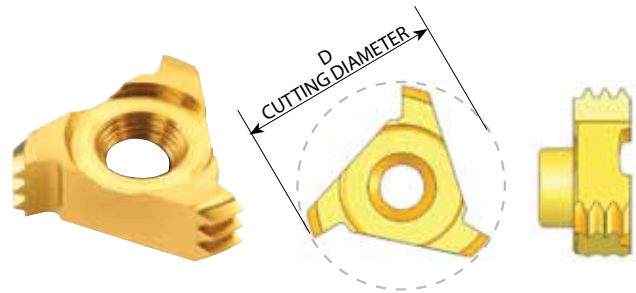

Insert Type	Pitch TPI	Nominal Size	UNC	UNF	UNEF	Ordering Code	Number of Teeth	D	Holder* Code
C10	20			1/2		C10 I 20 UN	2	.39	H1, 2, 15, 16, 17
	18			9/16		C10 I 18 UN	2	.39	
	13		1/2			C10 I 13 UN	1	.39	H1, 2, 15, 17
	12	5/8, 11/16, 3/4	9/16			C10 I 12 UN	1	.39	
C12	32	9/16, 5/8				C12 I 32 UN	3	.47	H3, 4, 5, 18, 19, 20
	28	9/16, 5/8, 11/16				C12 I 28 UN	3	.47	
	24				9/16, 5/8, 11/16	C12 I 24 UN	2	.47	
	20	9/16, 5/8, 11/16			3/4	C12 I 20 UN	2	.47	
	18			5/8		C12 I 18 UN	2	.47	
	16	5/8, 11/16		3/4		C12 I 16 UN	1	.47	
	11		5/8			C12 I 11 UN	1	.47	H3, 4, 5, 18, 20
	10		3/4			C12 I 10 UN	1	.47	
C18	32	3/4, 13/16, 7/8				C18 I 32 UN	6	.70	H6, 7, 8, 9, 21, 22, 23
	28	3/4, 13/16, 7/8				C18 I 28 UN	5	.70	
	24					C18 I 24 UN	4	.70	
	20	11/16, 11/8			13/16, 7/8, 15/16	C18 I 20 UN	3	.70	
	18					C18 I 18 UN	3	.70	
	16	7/8, 1				C18 I 16 UN	3	.70	
	14			7/8		C18 I 14 UN	2	.70	
	12	7/8		1, 11/8		C18 I 12 UN	2	.70	
	11					C18 I 11 UN	2	.70	
	9		7/8			C18 I 9 UN	1	.70	
8		1			C18 I 8 UN	1	.70		
C25	8	13/16, 11/4, 15/16				C25 I 8 UN	2	.98	H10, 11, 24, 25
	7		11/4			C25 I 7 UN	1	.98	
	6	17/16, 19/16	13/8, 11/2			C25 I 6 UN	1	.98	
	5		1 3/4			C25 I 5 UN	1	.98	
	4		2 1/2, 2 3/4			C25 I 4 UN	1	.98	

* For complete toolholder description see pages 225-226.

Full Profile - UN

Inserts for internal thread

Multi Flute

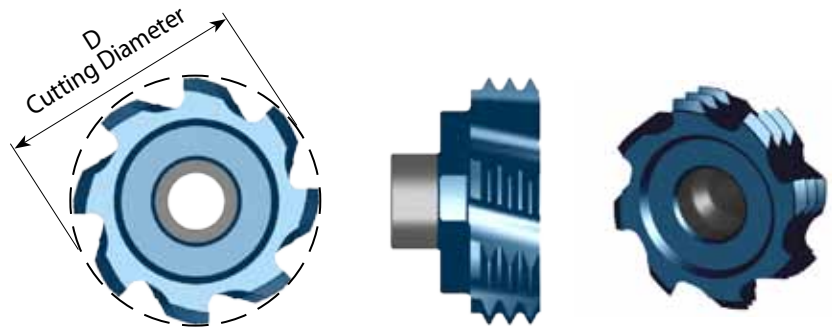

Insert Type	Ordering Code	Pitch TPI	Nominal size	UNC	UNF	UNEF	Number of Teeth	D	No. of Flutes	Holder* Code
S20	S160 H 24 UN	24				11/16	4	.63	8	H6, 7, 8, 9, 21, 22, 23
	S169 H 20 UN	20				3/4, 13/16, 7/8, 15/16, 1	4	.67	8	
	S164 F 16 UN	16	7/8, 15/16, 1		3/4		3	.65	6	
	S191 F 14 UN	14			7/8		2	.75	6	
	S186 F 12 UN	12	7/8, 15/16		1		2	.73	6	
	S178 F 9 UN	9		7/8			1	.70	6	
	S200 F 8 UN	8	1 1/8	1			1	.79	6	
	S200 F 7 UN	7		1 1/8, 1 1/4			1	.79	6	
	S200 E 6 UN	6	1 7/16	1 3/8, 1 1/2			1	.79	5	
	S200 D 5 UN	5		1 3/4			1	.79	4	H21
S35	S350 F 4 UN	4		2 1/2, 2 3/4, 3			1	1.38	6	H12, 13, 14, 26

G 55° BSW, BSF, BSP

Same Insert for internal and external thread

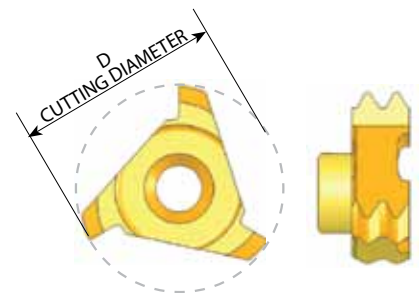

Insert Type	Pitch TPI	Standard	Ordering Code	Number of Teeth	D	Holder Code*
C10	19	G 1/4	C10 19 W	2	.39	H1, 2, 15, 16, 17
C12	19	G 3/8	C12 19 W	2	.47	H3, 4, 5, 18, 19, 20
C18	14	G 7/8	C18 14 W	2	.70	H6, 7, 8, 9, 21, 22, 23
	11	G ≥ 1	C18 11 W	2	.70	

* For complete toolholder description see pages 225-226.

Trapez - DIN 103

Inserts for internal thread

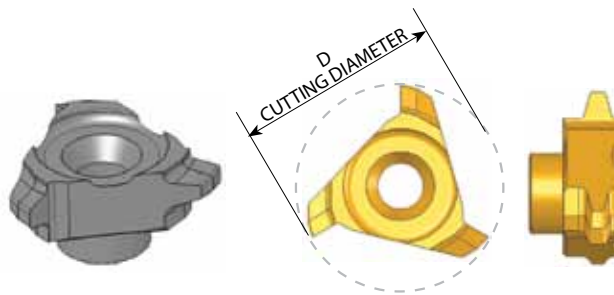

Insert Type	Pitch mm	Standard	Ordering Code	D	Holder Code*
C10	2.0	$\emptyset \geq .63$	C10 I 2 TR	.39	H1, 2, 15, 17
C18	3.0	$\emptyset \geq .94$	C18 I 3 TR	.70	H6, 7, 8, 9, 21, 22, 23
	4.0	$\emptyset \geq 1.02$	C18 I 4 TR	.70	H21
	5.0	$\emptyset \geq 1.10$	C18 I 5 TR	.70	
C25	6.0	$\emptyset \geq 1.42$	C25 I 6 TR	.98	H10, 11, 24, 25

Acme

Inserts for internal thread

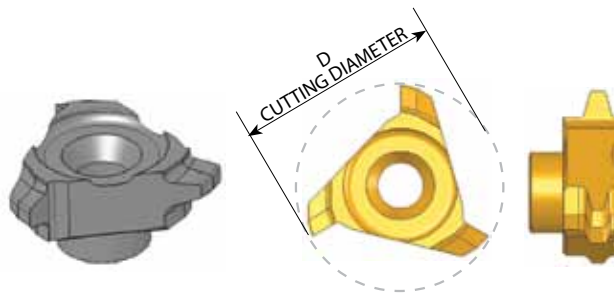

Insert Type	Pitch TPI	Standard	Ordering Code	D	Holder Code*
C18	5	1 ¹ / ₈ , 1 ¹ / ₄	C18 I 5 ACME	.71	Metric CRC 1218 P
C25	4	1 ¹ / ₂ , 1 ³ / ₄ , 2	C25 I 4 ACME	.98	H10, 11, 24, 25

Round - DIN 405

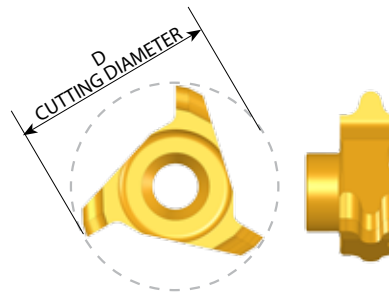

Insert Type	Pitch TPI	Standard	Ordering Code	D	Holder Code*
C18	8	1/8RD	C18 1/8RD	.70	H6, 7, 8, 9, 21, 22, 23
	6	1/6RD	C18 1/6RD	.70	H21
C25	4	1/4RD	C25 1/4RD	.98	H10, 11, 24, 25

* For complete toolholder description see pages 225-226.

Chamfering and Grooving

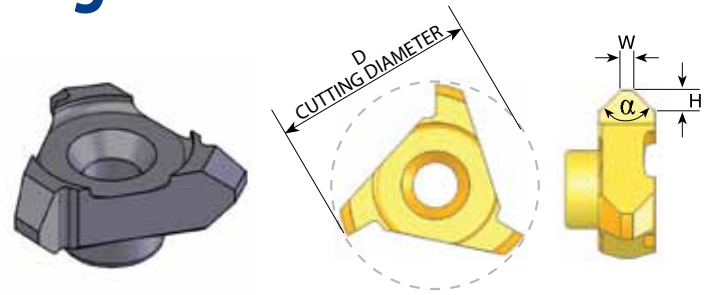

Insert Type	Ordering Code	D	H	W	α	Holder Code*
C10	C10 C90	.39	.051	.016	90°	H1, 2, 15, 17
C12	C12 C90	.47	.053	.012	90°	H3, 4, 5, 18, 20
C18	C18 C90	.70	.077	.043	90°	H6, 7, 8, 9, 21, 22, 23
C25	C25 C90	.98	.098	.039	90°	H10, 11, 24, 25

Chamfering, Grooving and Boring Multi Flute

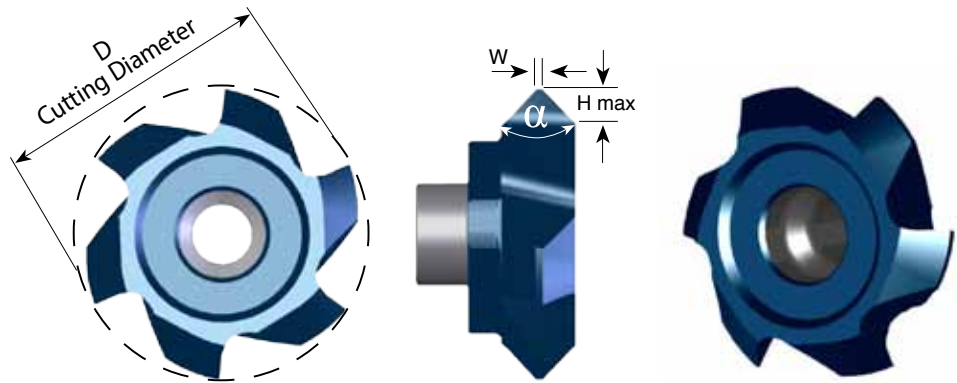

Insert Type	Ordering Code	D	H max	W	α	No. of Flutes	Holder Code
S17	SC160 E H14	.63	.053	.008	90°	5	H3, 4, 5, 18, 19, 20
S20	SC170 E H14	.67	.053	.008	90°	5	H6, 7, 8, 9, 21, 22, 23
	SC200 F H14	.79	.053	.008	90°	6	H6, 7, 8, 9, 21, 22, 23
	SC200 F H24	.79	.093	.008	90°	6	H6, 7, 8, 9, 21, 22, 23
S35	SC350 F H42	1.38	.165	.008	90°	6	H12, 13, 14, 26
S20	SC200 F H20	.79	.077	.039	90°	6	H6, 7, 8, 9, 21, 22, 23
	SC200 F H17	.79	.067	.059	90°	6	
	SC200 F H15	.79	.059	.079	90°	6	
	SC200 F H12	.79	.047	.079	90°	6	

* For complete toolholder description see pages 225-226.

Groove Milling

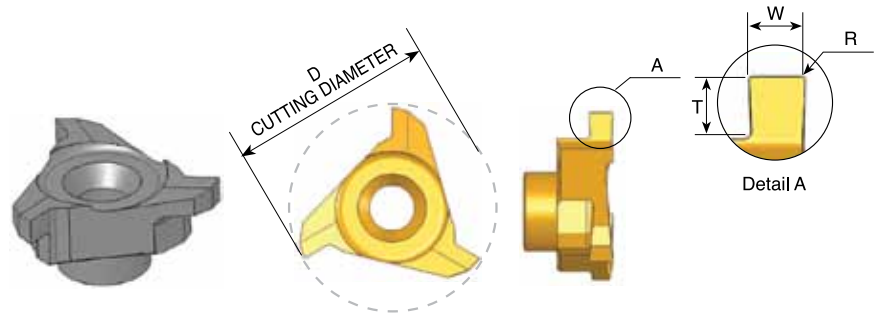

Insert Type	Ordering Code	D	W ±.001	T max.	R	Groove Dia. (min.)	Holder Code*
C10	C10 W08	.39	.031	.03	.004	$\phi > .39$	H1, 2, 15, 16, 17
	C10 W09	.39	.035	.04	.004	$\phi > .39$	
	C10 W10	.39	.039	.04	.004	$\phi > .39$	
	C10 W15	.39	.059	.05	.004	$\phi > .39$	
	C10 W20	.39	.079	.05	.004	$\phi > .39$	
C12	C12 W08	.47	.031	.03	.004	$\phi > .47$	H3, 4, 5,18,19,20
	C12 W10	.47	.039	.04	.004	$\phi > .47$	
	C12 W15	.49	.059	.06	.004	$\phi > .49$	
	C12 W20	.49	.079	.06	.004	$\phi > .49$	
	C12 W25	.49	.098	.06	.004	$\phi > .49$	
C18	C18 W10	.70	.039	.06	.004	$\phi > .70$	H6, 7, 8, 9, 21, 22, 23
	C18 W12	.70	.047	.06	.004	$\phi > .70$	
	C18 W15	.70	.059	.08	.004	$\phi > .70$	
	C18 W20	.70	.079	.11	.004	$\phi > .70$	H21
C25	C25 W20	.98	.079	.12	.008	$\phi > .98$	H10, 11, 24, 25
	C25 W25	.98	.098	.12	.008	$\phi > .98$	
	C25 W30	.98	.118	.12	.008	$\phi > .98$	
	C25 W35	.98	.138	.14	.008	$\phi > .98$	
	C25 W40	.98	.157	.14	.008	$\phi > .98$	
	C25 W50	.98	.197	.14	.008	$\phi > .98$	

* For complete toolholder description see pages 225-226.

Groove Milling

Multi Flute

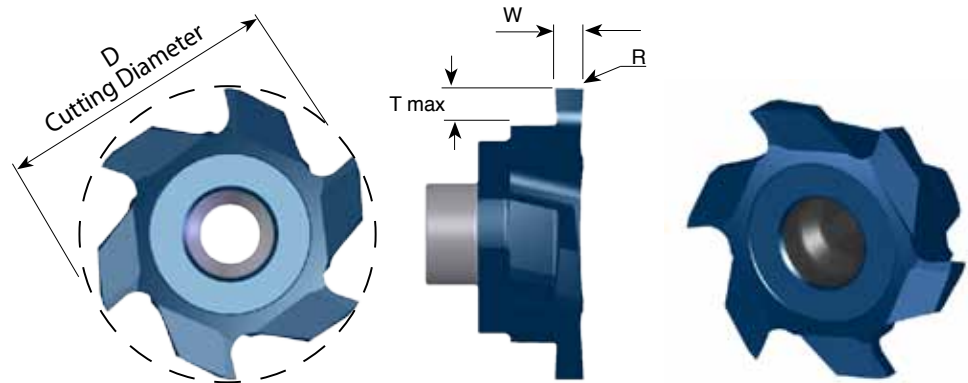

Insert Type	Ordering Code	D	W ±.001	T Max.	R	Groove Dia. (min)	No. of Flutes	Holder Code*
S17	SG170 F W15	.67	.059	.11	.008	Ø > .67	6	H3, 4, 5, 18, 19, 20
	SG170 F W20	.67	.079	.11	.008	Ø > .67	6	
	SG170 F W25	.67	.098	.11	.008	Ø > .67	6	
S20	SG200 F W15	.79	.059	.11	.008	Ø > .79	6	H6, 7, 8, 9, 21, 22, 23
	SG200 F W20	.79	.079	.11	.008	Ø > .79	6	
	SG200 F W25	.79	.098	.11	.008	Ø > .79	6	
	SG200 F W30	.79	.118	.11	.008	Ø > .79	6	
	SG200 F W40	.79	.157	.11	.008	Ø > .79	6	
	SG200 F W49	.79	.193	.11	.008	Ø > .79	6	
S20	SG200 E W20T	.79	.079	.15	.008	Ø > .79	5	H21
	SG200 E W25T	.79	.098	.15	.008	Ø > .79	5	
	SG200 E W30T	.79	.118	.15	.008	Ø > .79	5	
S35	SG350 F W30T	1.38	.118	.25	.008	Ø > 1.38	6	H12, 13, 14, 26
	SG350 F W40T	1.38	.157	.25	.008	Ø > 1.38	6	
	SG350 F W50T	1.38	.197	.25	.008	Ø > 1.38	6	
	SG350 F W60T	1.38	.236	.25	.008	Ø > 1.38	6	
	SG350 F W80T	1.38	.315	.25	.008	Ø > 1.38	6	

* For complete toolholder description see pages 225-226.

Full Radius Groove Milling Multi Flute

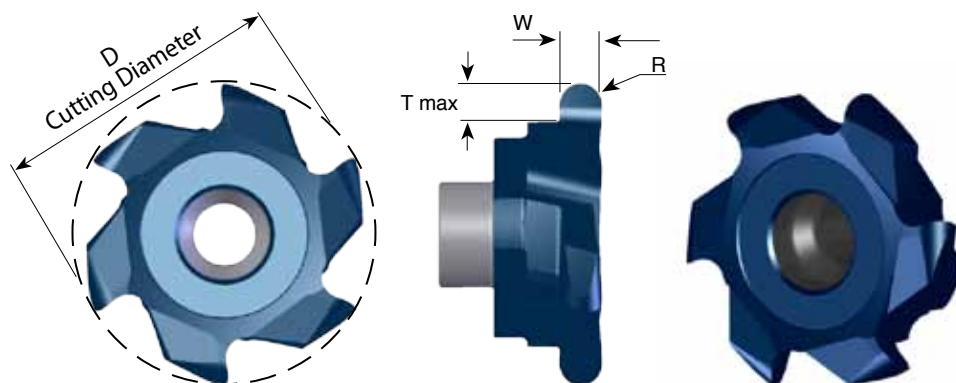

Insert Type	Ordering Code	D	R	W ±.001	T Max.	Groove Dia. (min)	No. of Flutes	Holder Code*
S20	SG200 F R10	.79	.039	.079	.11	Ø > .79	6	H6, 7, 8, 9, 21, 22, 23
	SG200 F R12	.79	.047	.094	.11	Ø > .79	6	
	SG200 F R15	.79	.059	.118	.11	Ø > .79	6	
	SG200 F R20	.79	.079	.157	.11	Ø > .79	6	

Face Milling and Finishing

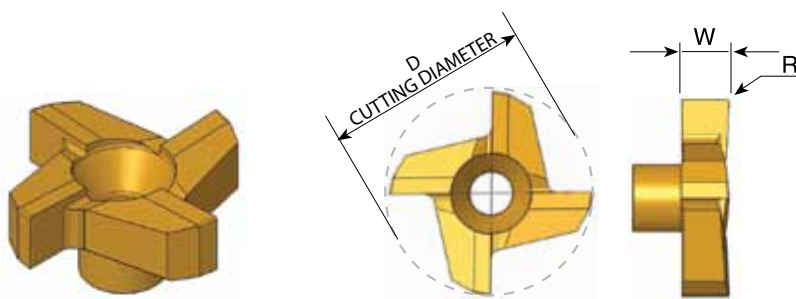

Insert Type	Ordering Code	D	W +.008	R	Holder Code*
C10	C10 F R0.1	.39	.12	.004	H1, 2, 15, 16, 17
C12	C12 F R0.1	.47	.12	.004	H3, 4, 5, 18, 19, 20
C18	C18 F R0.1	.70	.20	.004	H6, 7, 8, 9, 21, 22, 23
C25	C25 F R0.2	.98	.24	.008	H10, 11, 24, 25

* For complete toolholder description see pages 225-226.

Corner Rounding

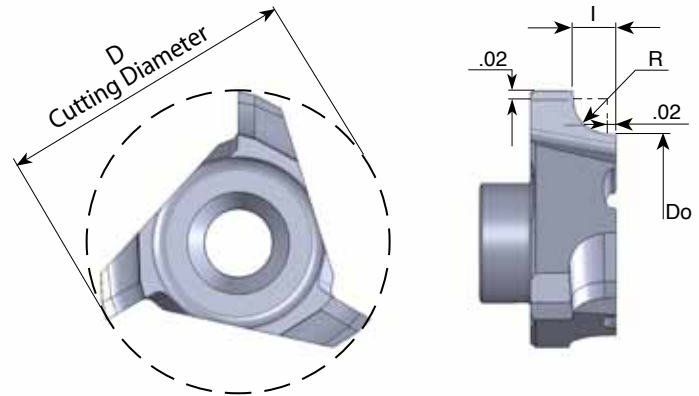

Insert Type	Ordering Code	D	Do	R	I	Holder Code*
C10	C10 CR05	.39	.31	.020	.04	H1, 2, 15, 16, 17
	C10 CR10	.39	.27	.039	.06	
C18	C18 CR13	.70	.56	.049	.07	H6, 7, 8, 9, 21, 22, 23
	C18 CR15	.70	.54	.059	.08	
	C18 CR20	.70	.50	.079	.10	

Corner Rounding Multi Flute

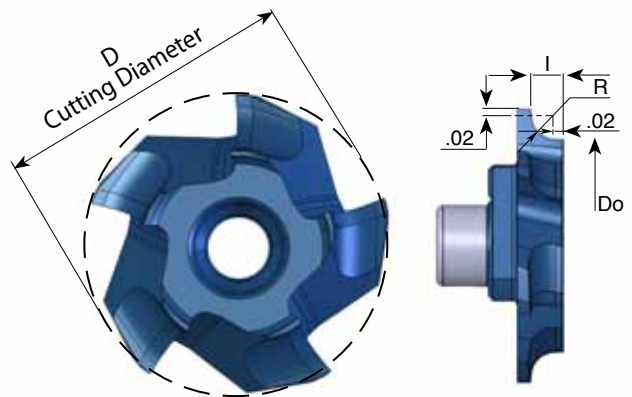

Insert Type	Ordering Code	D	Do	R	I	No. of Flutes	Holder Code*
S17	S170 F CR10	.67	.55	.039	.06	5	H3, 4, 5, 18, 19, 20
	S170 F CR13	.67	.53	.049	.07	5	
	S170 F CR15	.67	.51	.059	.08	5	

* For complete toolholder description see pages 225-226.

Steel Toolholders

With internal coolant

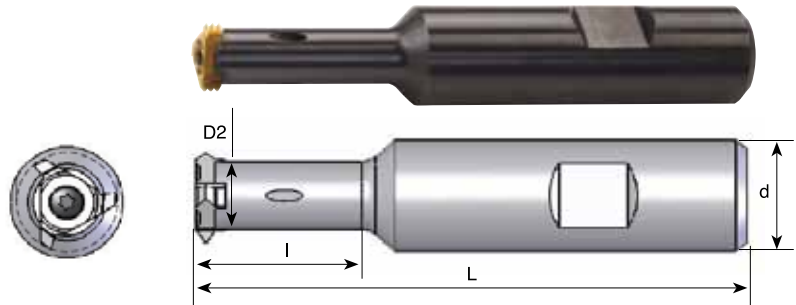

Tool No.	Ordering Code	Insert Type	d	D2	l	L	Insert Screw	Torx Key
H1	SRC 0500 E10	C10	.500	.29	.75	2.8	S5	K5
H2	SRC 0625 G10		.625	.29	.75	3.5		
H3	SRC 0500 E12	C12, S17	.500	.35	.98	2.8	S10	K10
H4	SRC 0625 G12		.625	.35	.98	3.5		
H5	SRC 0625 H12		.625	.35	1.38	4.0		
H6	SRC 0625 H18	C18, S20	.625	.54	1.89	4.0	S16	K16
H7	SRC 0750 H18		.750	.54	1.26	4.0		
H8	SRC 0750 J18		.750	.54	1.89	4.5		
H9	SRC 0750 L18		.750	.54	2.91	5.5		
H10	SRC 1000 J25	C25	1.00	.69	1.77	4.5	S27	K27
H11	SRC 1000 M25		1.00	.69	3.15	5.9		
H12	SRC 0750 P35	S35	.750	.87	-	6.7	S33	K33
H13	SRC 1000 H35		1.00	.87	1.57	3.9		
H14	SRC 1000 K35		1.00	.87	2.36	5.1		

Carbide Shank Toolholders

With internal coolant

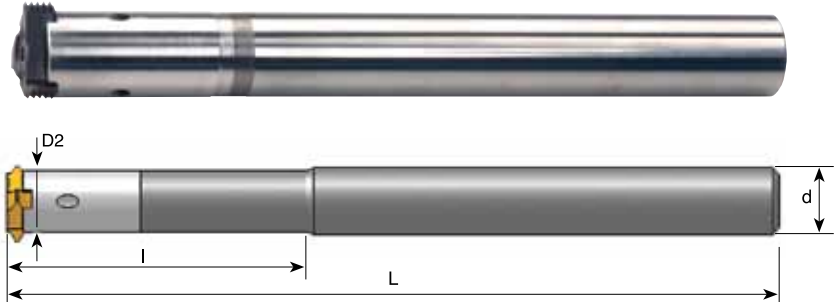

Tool No.	Ordering Code	Insert Type	d	D2	l	L	Insert Screw	Torx Key
H15	CRC 0312 L13 K10	C10	.312	.29	1.38	5.0	S5	K5
H16	CRC 0312 K10		.312	.312	-	5.0	S5	K5
H17	CRC 0312 L17 M10		.312	.29	1.77	5.9	S5	K5
H18	CRC 0375 L15 M12	C12, S17	.375	.35	1.58	6.0	S10	K10
H19	CRC 0375 M12		.375	.375	-	6.0	S10	K10
H20	CRC 0500 L22 P10		.500	.35	2.24	6.7	S10	K10
H21	CRC 0500 P18	C18, S20	.500	.500	-	7.0	S16	K16
H22	CRC 0625 L18 R18		.625	.54	1.89	7.8	S16	K16
H23	CRC 0625 L29 R18		.625	.54	2.91	7.8	S16	K16
H24	CRC 0625 R25	C25	.625	.69	-	8.2	S27	K27
H25	CRC 0750 L33 S25		.750	.69	3.35	10.0	S27	K27
H26	CRC 0750 S35		S35	.750	.87	-	10.2	S33

Tools without Weldon

CMT Multi Insert Milling Cutters

Carmex presents a new generation of CMT indexable milling inserts and cutters for Grooving, Chamfering and Threading.



Inserts

- Insert profiles are fully ground
- Spiral inserts for smooth cutting operation
- Three cutting edges on each insert
- For a wide range of materials and applications

Carbide grade: MT7



Milling cutters / Disc milling cutter

- 4 - 8 inserts per holder, for high productivity
- To use with Carmex standard CMT - S35 toolholders
- The milling cutters are coated with a special layer (silver color) for high Anti-corrosive resistance and extra protection against cutting burrs

Product Identification - Ordering Codes

Inserts

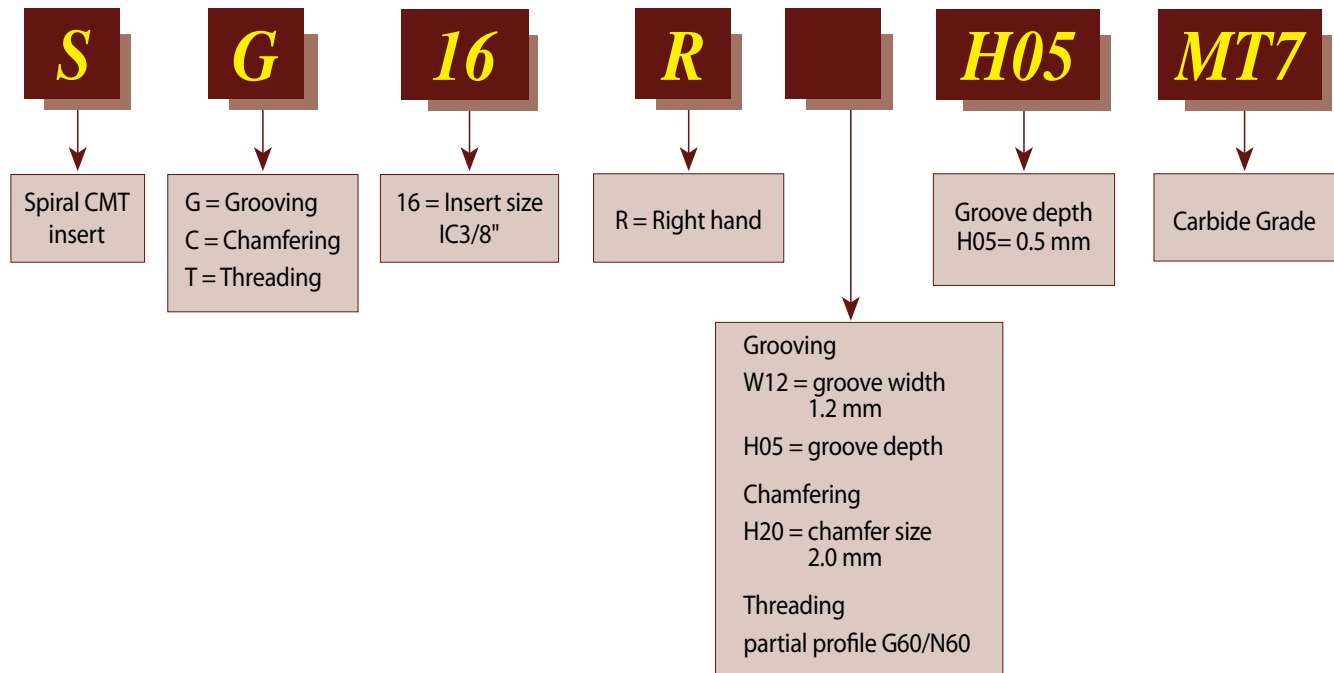

Toolholders

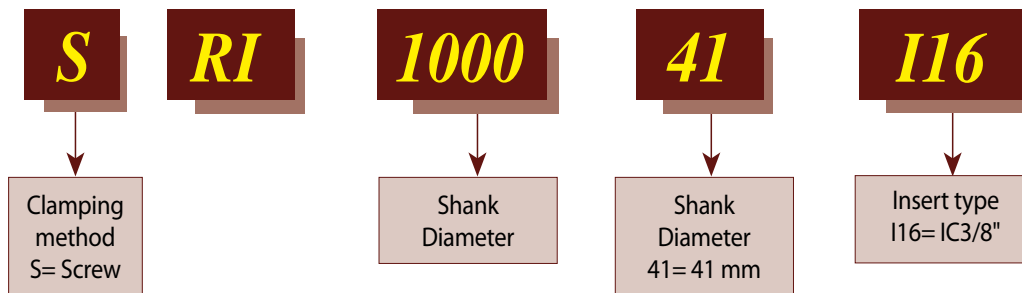

Groove Milling

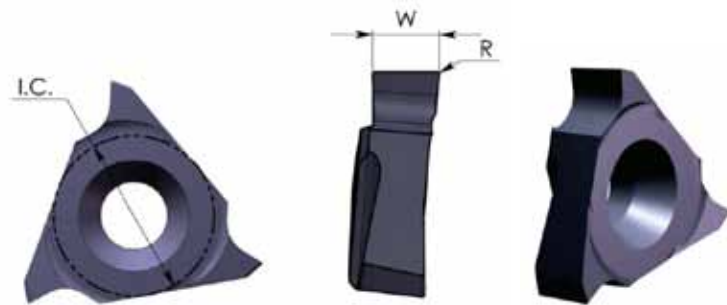

DIN 471 / 472

Insert Type	I.C.	Ordering Code	W	R	Holder Code
SI16	3/8"	SG 16 R W14	.055	.004	H27, H28
		SG 16 R W17	.067	.004	
		SG 16 R W19	.077	.006	
		SG 16 R W22	.089	.006	
		SG 16 R W27	.108	.008	
		SG 16 R W32	.128	.008	
		SG 16 R W42	.167	.008	
		*SG 16 R W43	.171	.008	H27, H28, H29

Right hand cutting

Insert Type	I.C.	Ordering Code	W	R	Holder Code
SI16	3/8"	SG 16 L W43	.171	.008	H29

Left hand cutting

* T max = .08

When using holders SRI41-I16 and SRI2541-I16

** Maximum groove depth (T max) according to the toolholder.

Groove Milling with Chamfer

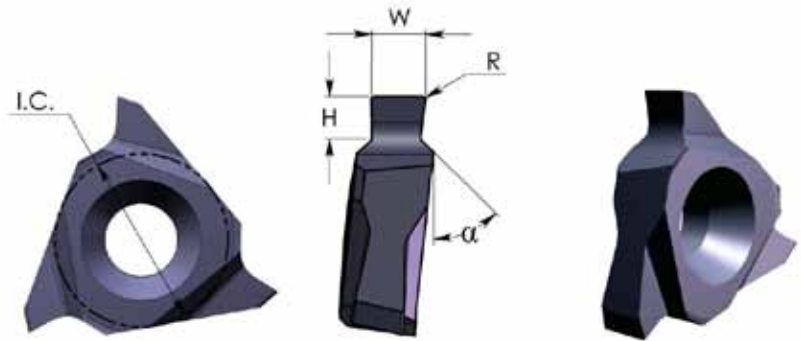

DIN 471 / 472

Insert Type	I.C.	Ordering Code	W	H max	R	α	Holder Code
SI16	3/8"	SG 16 R W12 H05	.047	.020	.004	45°	H27, H28
		SG 16 R W14 H07	.055	.028	.004		
		SG 16 R W14 H08	.055	.033	.004		
		SG 16 R W17 H08	.067	.033	.004		
		SG 16 R W17 H10	.067	.039	.004		
		SG 16 R W19 H12	.077	.049	.006		
		SG 16 R W22 H15	.089	.059	.006		
		SG 16 R W27 H15	.108	.059	.006		
		SG 16 R W27 H17	.108	.069	.006		
		SG 16 R W32 H17	.128	.069	.006		
		SG 16 R W42 H20	.167	.079	.006		
		SG 16 R W42 H25	.167	.098	.006		

Right hand cutting

Chamfering

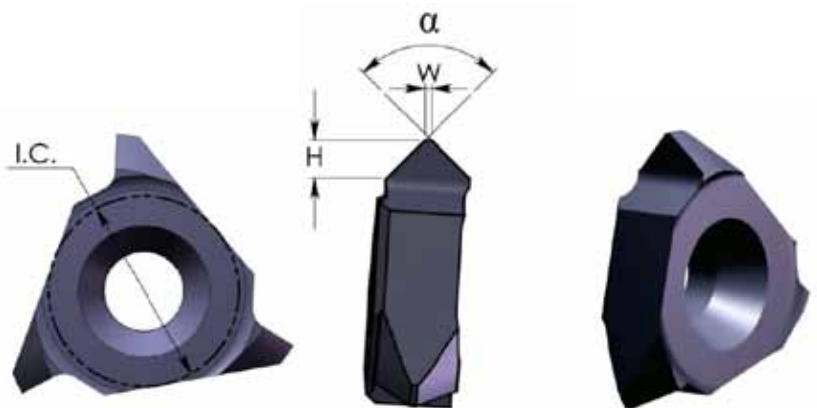

Insert Type	I.C.	Ordering Code	H max	W	α	Holder Code
SI16	3/8"	SC 16 R H20	.079	.008	90°	H27, H28
		SC 16 R H19	.075	.020		

Maximum groove depth (T max) according to the toolholder.

Partial Profile 60° - ISO, UN

Same Insert for internal and external thread

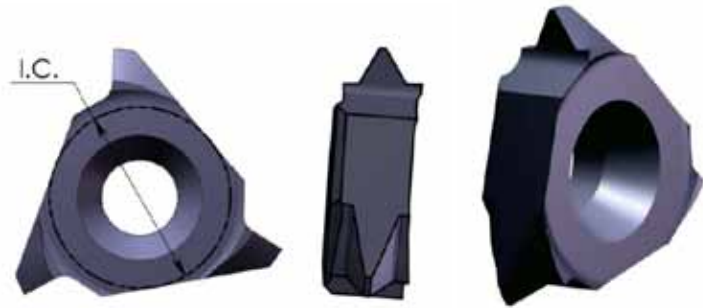

Insert Type	I.C.	Ordering Code	Pitch Range mm	Pitch Range TPI	Holder Code
SI16	3/8"	ST 16 R G60	1.5-3.0	16-8	H27, H28
		ST 16 R N60	3.5-5.0	7-5	

Right hand cutting

Toolholders

Milling Cutter- Arbor

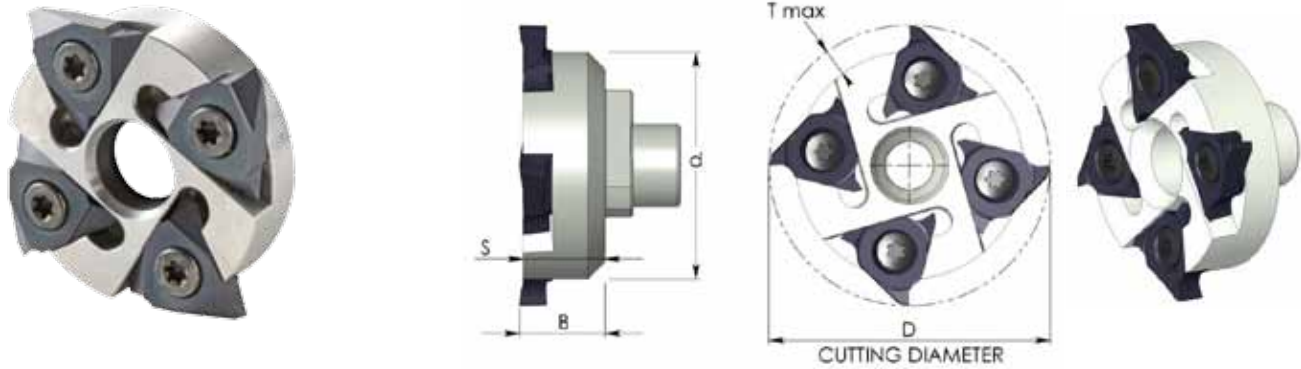

Tool No.	Ordering Code	Insert type	D	d	T max	B	S	Insert Screw	Torx Key
H27	SRI 41- I16	SI16	1.614	1.307	.142	.492	.472	S16S	K16

Right hand cutting

To connect to the standard CMT toolholders S35: SRC 0750 P35, SRC 1000 H35, SRC 1000 K35, CRC 0750 S35.

Milling Cutter- Weldon Shank

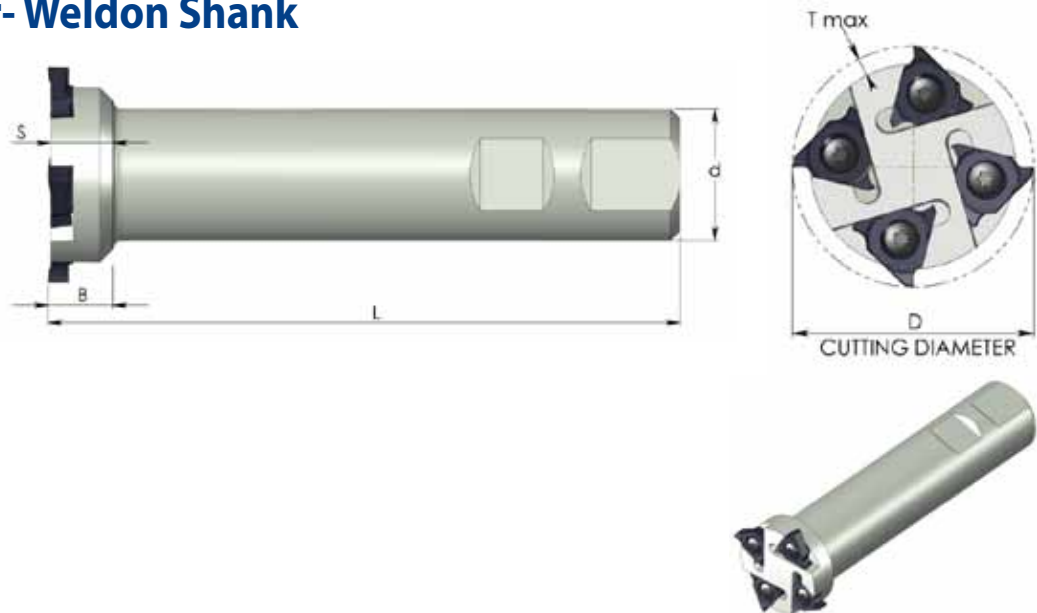

Tool No.	Ordering Code	Insert type	D	d	T max	B	S	L	Insert Screw	Torx Key
H28	SRI 1000-I16	SI16	1.614	1.000	.142	.492	.472	4.9	S16S	K16

Right hand cutting

Mill Cutter - Disc Milling

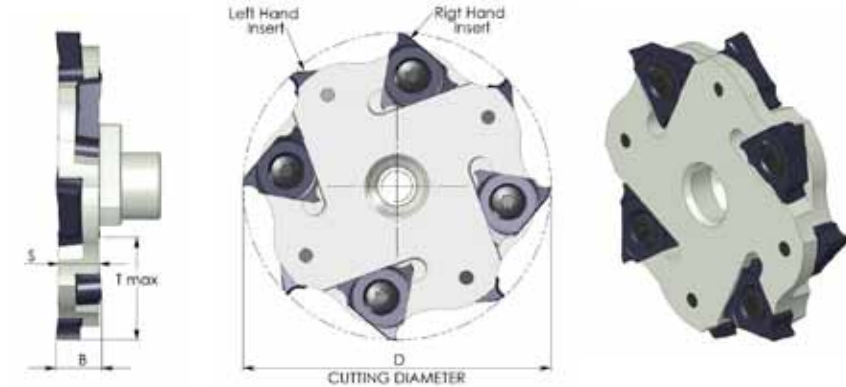

Tool No.	Ordering Code	Insert type	D	T max	B	S	Insert Screw	Torx Key
H29	SRI 55-I16	SI16	2.165	.610	.323	.283	S16M	K16

Right hand cutting

To use only with inserts SG 16 RW43, and SG 16 LW43

To connect to the standard CMT toolholders S35: SRC 0750 P35, SRC 1000 H35, SRC 1000 K35, CRC 0750 S35.

Mill-Thread Solid Carbide



Advantages of Mill-Thread Solid Carbide

- Thread is generated in one pass.
- Spiral flutes allow smooth cutting action.
- Shorter machining time due to multi, 3 to 6, flutes.
- 2.2 mm and up cutting diameter.
- Threads up to shoulder in blind hole.
- Longer tool life due to special multi-layer coating.
- Same tool can be used for a variety of materials.
- Excellent surface finish.
- Low cutting pressure allows thin wall machining.
- Same tool used for R.H and L.H. threads.

MT - Thread Mills without internal coolant

MTB - Thread Mills with internal coolant bore for blind holes

MTZ - Thread Mills with internal coolant through the flutes

MTQ - Thread Mills that include relieved neck for deep work pieces

FMT - Fast Thread Mills with internal coolant bore

Contents:

Page:

Contents:

Page:

Product Identification	236	NPT - with internal Coolant Bore - MTB	250
ISO	237	NPT - with internal Coolant through the Flutes - MTZ	251
ISO - with internal Coolant Bore - MTB	238	NPTF	251
ISO - with internal Coolant through the Flutes - MTZ	239	NPTF - with internal Coolant Bore - MTB	252
ISO - with internal Coolant Bore - MTQ	240	NPTF - with internal Coolant through the Flutes - MTZ	252
ISO - with internal Coolant Bore - FMT	241	Solid Carbide Tapered End Mills	253
G (55°)	241	NPS - with internal Coolant Bore - MTB	254
G (55°) - with internal Coolant Bore - MTB	242	NPSF - with internal Coolant Bore - MTB	254
G (55°) - with internal Coolant through the Flutes - MTZ	242	PG DIN 40430 - with internal Coolant Bore MTB	255
G (55°) - with internal Coolant through the Flutes - FMT	243	Mill - Thread Solid Carbide for External Threads	256
Whitworth - with internal Coolant through the Flutes - MTZ	243	ISO	256
UN	244	UN	256
UN - with internal Coolant Bore - MTB	245	MJ	257
UN - with internal Coolant through the Flutes - MTZ	246	UNJ	257
UN - with internal Coolant Bore - MTQ	247	AMT - Solid Carbide Thread Mills for Aluminum	258
UN - with internal Coolant Bore - FMT	248	ISO - with internal Coolant Bore	259
BSPT	248	ISO - With internal coolant bore and cutting Chamfer	259
BSPT - with internal Coolant Bore - MTB	249	UN - With internal coolant bore	260
BSPT - with internal Coolant through the Flutes - MTZ	249	UN - With internal coolant bore and cutting Chamfer	260
NPT	250		

Product Identification

Mill-Thread Solid Carbide Ordering Codes

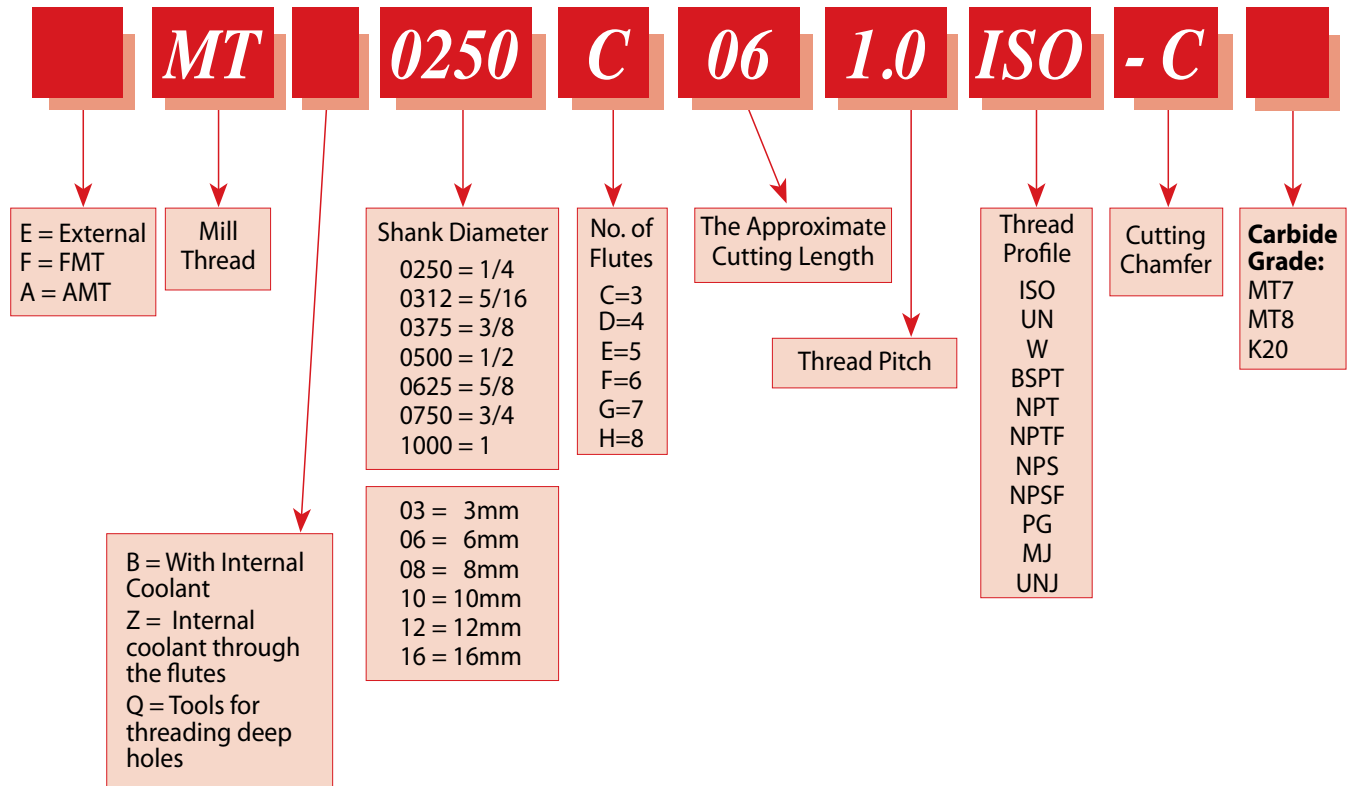

ISO

Tools for Internal thread

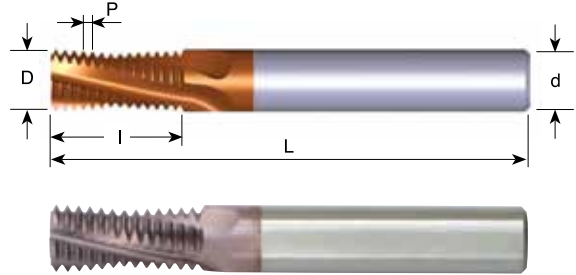
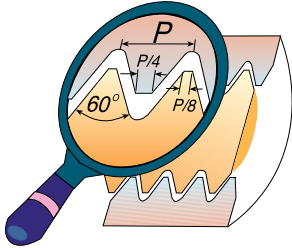

Pitch mm	M coarse	M fine mm	Ordering Code	d	D	No. of Flutes	l	L
0.5	M3	$\varnothing \geq 4$	MT0250C02 0.5 ISO	1/4	.087	3	.21	2.5
0.5		$\varnothing \geq 5$	MT0250C04 0.5 ISO	1/4	.150	3	.41	2.5
0.7	M4	$\varnothing \geq 5$	MT0250C03 0.7 ISO	1/4	.122	3	.29	2.5
0.75		$\varnothing \geq 6$	MT0250C04 0.75 ISO	1/4	.177	3	.40	2.5
0.8	M5	$\varnothing \geq 6$	MT0250C04 0.8 ISO	1/4	.142	3	.36	2.5
1.0	M6	$\varnothing \geq 7$	MT0250C04 1.0 ISO	1/4	.157	3	.41	2.5
1.0	M6	$\varnothing \geq 7$	MT0250C06 1.0 ISO	1/4	.157	3	.57	2.5
1.0		$\varnothing \geq 9$	MT0250C05 1.0 ISO	1/4	.236	3	.49	2.5
1.0		$\varnothing \geq 10$	MT0312D07 1.0 ISO	5/16	.313	4	.65	2.5
1.25	M8	$\varnothing \geq 10$	MT0250C06 1.25 ISO	1/4	.197	3	.57	2.5
1.25	M8	$\varnothing \geq 10$	MT0250C07 1.25 ISO	1/4	.197	3	.76	2.5
1.5	M10	$\varnothing \geq 12$	MT0312C07 1.5 ISO	5/16	.276	3	.68	2.5
1.5	M10	$\varnothing \geq 12$	MT0312C09 1.5 ISO	5/16	.276	3	.98	2.5
1.5		$\varnothing \geq 14$	MT0375D09 1.5 ISO	3/8	.375	4	.86	3.0
1.5		$\varnothing \geq 20$	MT0625F13 1.5 ISO	5/8	.625	6	1.33	4.0
1.75	M12	$\varnothing \geq 14$	MT0312C08 1.75 ISO	5/16	.313	3	.79	2.5
1.75	M12	$\varnothing \geq 14$	MT0312C11 1.75 ISO	5/16	.313	3	1.14	2.5
2.0	M16	$\varnothing \geq 17$	MT0375C11 2.0 ISO	3/8	.375	3	1.06	3.0
2.0	M16	$\varnothing \geq 17$	MT0375C15 2.0 ISO	3/8	.375	3	1.54	4.0
2.0		$\varnothing \geq 18$	MT0500D11 2.0 ISO	1/2	.472	4	1.06	3.5
2.0		$\varnothing \geq 26$	MT0750F16 2.0 ISO	3/4	.750	6	1.61	4.0
2.5	M20	$\varnothing \geq 22$	MT0625D13 2.5 ISO	5/8	.551	4	1.33	4.0
2.5	M20	$\varnothing \geq 22$	MT0625D19 2.5 ISO	5/8	.551	4	1.92	4.0
3.0	M24	$\varnothing \geq 25$	MT0625C16 3.0 ISO	5/8	.625	3	1.59	4.0
3.0	M24	$\varnothing \geq 25$	MT0625C23 3.0 ISO	5/8	.625	3	2.31	4.5
3.0	M27	$\varnothing \geq 28$	MT0750D17 3.0 ISO	3/4	.750	4	1.71	4.0

Order example: MT 0500D11 2.0 ISO MT7

For thread mills with coolant bore see following pages

For small thread mills see pages 263-264, 270, 274 & 285.



ISO With internal coolant bore

Tools for Internal thread

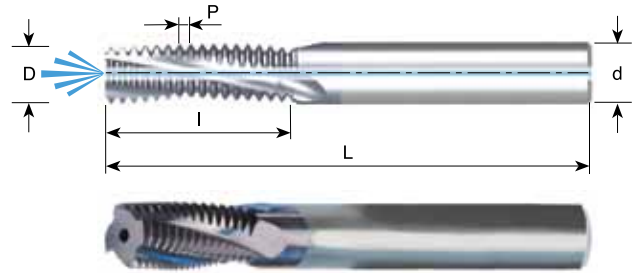
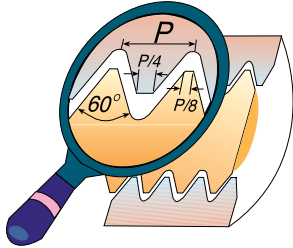

Pitch mm	M coarse	M fine mm	Ordering Code	d	D	No. of Flutes	I	L
0.5		$\varnothing \geq 5$	MTB0250C04 0.5 ISO	1/4	.150	3	.41	2.5
0.7	M4	$\varnothing \geq 5$	MTB0250C02 0.7 ISO	1/4	.122	3	.29	2.5
0.75		$\varnothing \geq 6$	MTB0250C04 0.75 ISO	1/4	.177	3	.40	2.5
0.8	M5	$\varnothing \geq 6$	MTB0250C03 0.8 ISO	1/4	.150	3	.36	2.5
1.0	M6	$\varnothing \geq 7$	MTB0250C04 1.0 ISO	1/4	.181	3	.41	2.5
1.0	M6	$\varnothing \geq 7$	MTB0250C06 1.0 ISO	1/4	.181	3	.57	2.5
1.0		$\varnothing \geq 9$	MTB0250C05 1.0 ISO	1/4	.250	3	.50	2.5
1.0		$\varnothing \geq 10$	MTB0312D06 1.0 ISO	5/16	.312	4	.65	2.5
1.0		$\varnothing \geq 12$	MTB0375D09 1.0 ISO	3/8	.375	4	.96	3.0
1.25	M8	$\varnothing \geq 10$	MTB0250C05 1.25 ISO	1/4	.249	3	.57	2.5
1.25	M8	$\varnothing \geq 10$	MTB0250C07 1.25 ISO	1/4	.249	3	.76	2.5
1.5	M10	$\varnothing \geq 12$	MTB0312C06 1.5 ISO	5/16	.306	3	.67	2.5
1.5	M10	$\varnothing \geq 12$	MTB0312C09 1.5 ISO	5/16	.306	3	.98	2.5
1.5		$\varnothing \geq 14$	MTB0375D08 1.5 ISO	3/8	.375	4	.86	3.0
1.5		$\varnothing \geq 16$	MTB0500D10 1.5 ISO	1/2	.500	4	1.04	4.0
1.5		$\varnothing \geq 20$	MTB0625F13 1.5 ISO	5/8	.625	6	1.33	4.0
1.75	M12	$\varnothing \geq 12$	MTB0375C07 1.75 ISO	3/8	.354	3	.79	3.0
1.75	M12	$\varnothing \geq 12$	MTB0375C11 1.75 ISO	3/8	.354	3	1.14	3.0
2.0	M14	$\varnothing \geq 15$	MTB0375C10 2.0 ISO	3/8	.375	3	1.06	3.0
2.0	M16	$\varnothing \geq 17$	MTB0500D10 2.0 ISO	1/2	.465	4	1.06	4.0
2.0	M16	$\varnothing \geq 17$	MTB0500D15 2.0 ISO	1/2	.465	4	1.54	4.0
2.0		$\varnothing \geq 26$	MTB0750F16 2.0 ISO	3/4	.750	6	1.61	4.0
2.5	M20	$\varnothing \geq 22$	MTB0625E13 2.5 ISO	5/8	.591	5	1.33	4.0
2.5	M20	$\varnothing \geq 22$	MTB0625E19 2.5 ISO	5/8	.591	5	1.92	4.0
3.0	M24	$\varnothing \geq 25$	MTB0750D15 3.0 ISO	3/4	.709	4	1.59	4.0
3.0	M27	$\varnothing \geq 27$	MTB0750D17 3.0 ISO	3/4	.750	4	1.71	4.0

Order example: MTB 0312C06 1.5 ISO MT7

For thread mills with coolant through the flutes see next page

For small thread mills see pages 263-264, 270, 274 & 285.



ISO With internal coolant through the flutes

Tools for Internal Thread - Metric Shanks

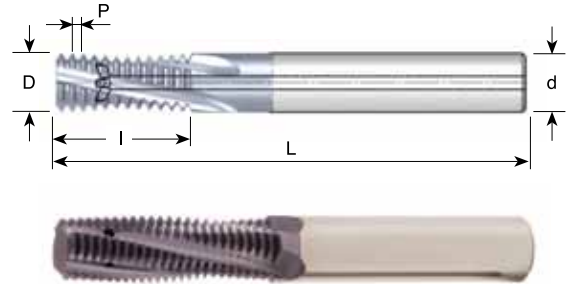
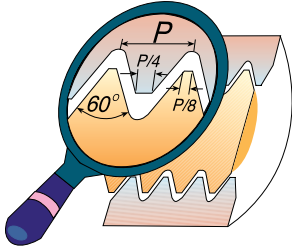

Pitch mm	M coarse	M fine mm	Ordering Code	d mm	D	No. of Flutes	I	L
1.0	M6	$\varnothing \geq 7$	MTZ06048C10 1.0 ISO	6	.189	3	.41	2.3
1.0		$\varnothing \geq 9$	MTZ0606C12 1.0 ISO	6	.236	3	.49	2.3
1.0		$\varnothing \geq 10$	MTZ0808D16 1.0 ISO	8	.315	4	.65	2.5
1.25	M8	$\varnothing \geq 10$	MTZ0606C14 1.25 ISO	6	.236	3	.57	2.3
1.25	M8	$\varnothing \geq 10$	MTZ0606C19 1.25 ISO	6	.236	3	.76	2.3
1.5	M10	$\varnothing \geq 12$	MTZ08078C17 1.5 ISO	8	.307	3	.67	2.5
1.5		$\varnothing \geq 14$	MTZ1010D21 1.5 ISO	10	.394	4	.86	2.9
1.5		$\varnothing \geq 16$	MTZ1212D26 1.5 ISO	12	.472	4	1.03	3.3
1.5		$\varnothing \geq 20$	MTZ1616E33 1.5 ISO	16	.630	5	1.33	4.0
1.75	M12	$\varnothing \geq 12$	MTZ1009C20 1.75 ISO	10	.354	3	.79	2.9
1.75	M12	$\varnothing \geq 12$	MTZ1009C28 1.75 ISO	10	.354	3	1.14	2.9
2.0	M14	$\varnothing \geq 15$	MTZ1010C27 2.0 ISO	10	.394	3	1.06	2.9
2.0	M16	$\varnothing \geq 17$	MTZ12118D27 2.0 ISO	12	.465	4	1.06	3.3
2.5	M20	$\varnothing \geq 22$	MTZ1615E33 2.5 ISO	16	.591	5	1.33	4.0

Order example: MTZ 08078C17 1.5 ISO MT7

For small thread mills see pages 263-264, 270, 274 & 285.



ISO With relieved neck and internal coolant bore

Tools for Internal Thread - Metric Shank

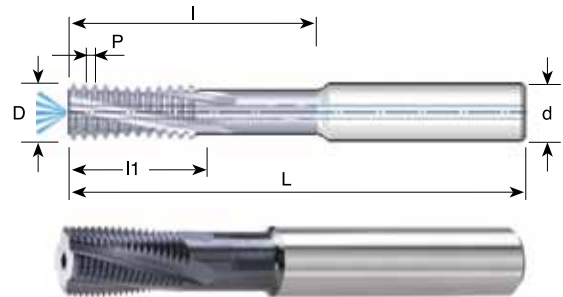
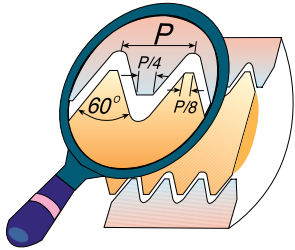

Pitch mm	M fine mm	Ordering Code	d mm	D	No. of Flutes	l1	l	L
1.0	$\emptyset \geq 12$	MTQ1010D32 1.0 ISO	10	.394	4	.71	1.26	2.9
1.0	$\emptyset \geq 14$	MTQ1212D38 1.0 ISO	12	.472	4	.83	1.50	3.3
1.0	$\emptyset \geq 18$	MTQ1616F45 1.0 ISO	16	.630	6	1.02	1.77	4.1
1.5	$\emptyset \geq 13$	MTQ1010D30 1.5 ISO	10	.394	4	.71	1.18	2.9
1.5	$\emptyset \geq 15$	MTQ1212D34 1.5 ISO	12	.472	4	.77	1.36	3.3
1.5	$\emptyset \geq 19$	MTQ1616F43 1.5 ISO	16	.630	6	1.00	1.71	4.1
1.5	$\emptyset \geq 23$	MTQ2020F60 1.5 ISO	20	.787	6	1.42	2.36	4.1
2.0	$\emptyset \geq 16$	MTQ1212D42 2.0 ISO	12	.472	4	.94	1.65	3.3
2.0	$\emptyset \geq 20$	MTQ1616E45 2.0 ISO	16	.630	5	1.02	1.77	4.1
2.0	$\emptyset \geq 24$	MTQ2020F56 2.0 ISO	20	.787	6	1.34	2.20	4.1
3.0	$\emptyset \geq 22$	MTQ1616D45 3.0 ISO	16	.630	4	1.18	1.77	4.1
3.0	$\emptyset \geq 26$	MTQ2020E54 3.0 ISO	20	.787	5	1.30	2.13	4.1
3.5	$\emptyset \geq 26$	MTQ2020D45 3.5 ISO	20	.787	4	1.10	1.79	4.1
4.0	$\emptyset \geq 31$	MTQ2525D64 4.0 ISO	25	.984	4	1.58	2.52	6.3

Order example: MTQ 1010D30 1.5 ISO MT7

For small thread mills see pages 263-264, 270, 274 & 285.



ISO Fast MT With internal coolant bore

Tools for Internal thread

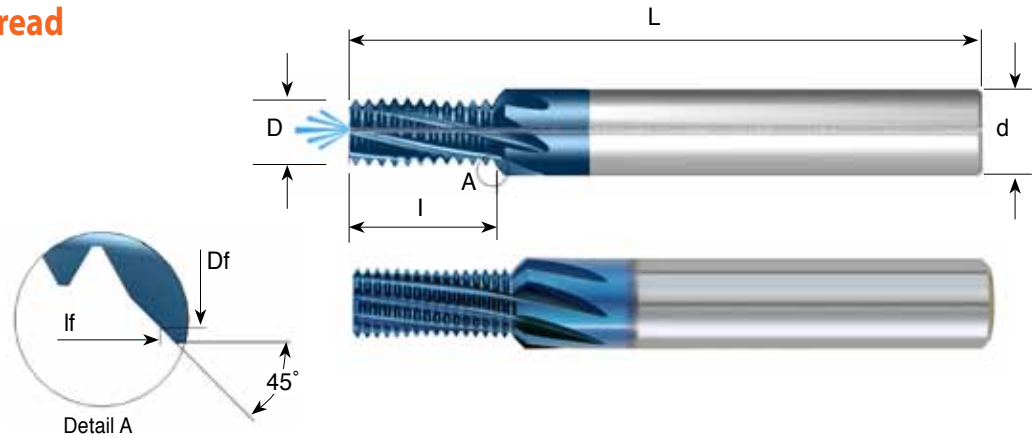

Pitch mm	M coarse	M fine	Ordering Code	d mm	D	Df	Flutes	I	lf	L
0.7	M4		FMT 06032 E7 0.7 ISO	6	.126	.189	5	.29	.32	2.3
0.8	M5		FMT 0604 E9 0.8 ISO	7	.157	.224	5	.36	.40	2.3
1.0	M6	M8	FMT 08048 F10 1.0 ISO	8	.189	.268	6	.41	.45	2.5
1.25	M8	M10	FMT 10064 G14 1.25 ISO	10	.252	.378	7	.57	.63	2.9
1.5	M10	M14	FMT 1008 G17 1.5 ISO	10	.315	.386	7	.68	.72	2.9
1.75	M12		FMT 12095 G20 1.75 ISO	12	.374	.461	7	.79	.83	3.3

G (55°) BSF, BSP

Same Tool for Internal and External Thread - Metric shanks

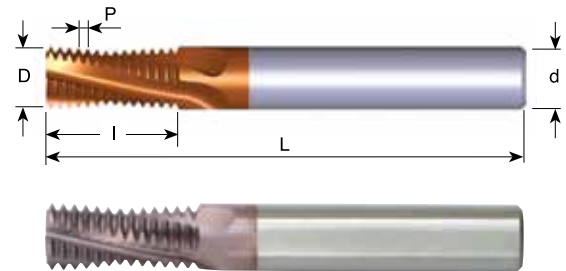
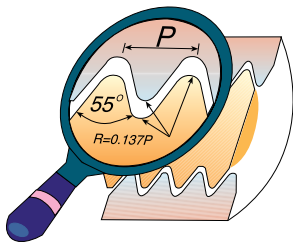

Pitch TPI	Standard	Ordering Code	d mm	D	No. of Flutes	I	L
28	G1/16-G1/8	MT0606C9 28 W	6	.236	3	.38	2.3
19	G1/4-3/8	MT0808C14 19 W	8	.315	3	.55	2.5
14	G1/2-7/8	MT1212D19 14 W	12	.472	4	.75	3.3
14	G1/2-7/8	MT1212D26 14 W	12	.472	4	1.04	3.3
11	G1-1 ^{1/2}	MT1212C24 11 W	12	.472	3	.95	3.3
11	G ≥ 1	MT1616D38 11 W	16	.630	4	1.50	4.1
11	G ≥ 1	MT2020E47 11 W	20	.787	5	1.86	4.1

Order example: MT 1212D19 14 W MT7

G (55°) BSF, BSP With internal coolant bore

Same Tool for Internal and External Thread - Metric shanks

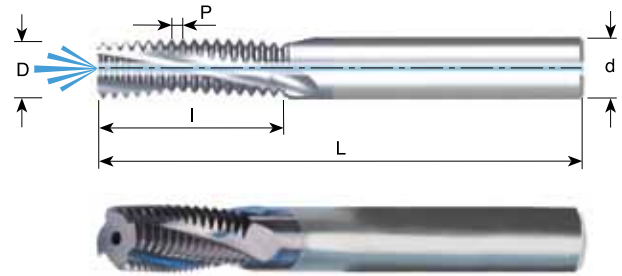

Pitch TPI	Standard	Ordering Code	d mm	D	No. of Flutes	I	L
28	G1/8	MTB08078C14 28W	8	.307	3	.56	2.5
19	G1/4-3/8	MTB1010D16 19W	10	.394	4	.66	2.9
14	G1/2-7/8	MTB1616E26 14W	16	.630	5	1.04	4.1
11	G ≥ 1	MTB1616D38 11W	16	.630	4	1.50	4.1
11	G ≥ 1	MTB2020E47 11W	20	.787	5	1.86	4.1

Order example: MTB 1010D16 19 W MT7

For thread mills with coolant bore through the flutes see next page

For small thread mills see page 267

G 55° BSF, BSP With internal coolant through the flutes

Same Tool for Internal and External Thread - Metric shanks

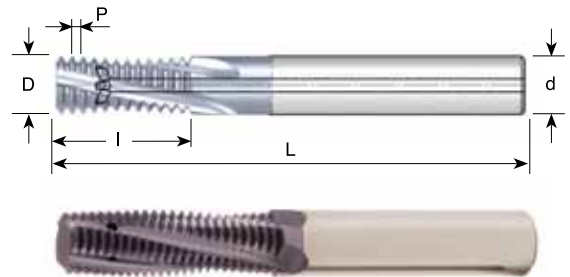
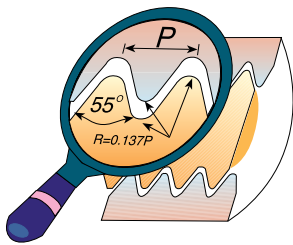

Pitch TPI	Standard	Ordering Code	d mm	D	No. of Flutes	I	L
28	G1/8	MTZ08078C14 28W	8	.307	3	.56	2.5
19	G1/4-3/8	MTZ1010D16 19W	10	.394	4	.66	2.9
14	G1/2-7/8	MTZ1616E26 14W	16	.630	5	1.04	4.0
11	G ≥ 1	MTZ1616D38 11W	16	.630	4	1.50	4.0

Order example: MTZ 08078C14 28 W MT7

For small thread mills see page 267

G 55° Fast MT With internal coolant bore

Same Tool for Internal and External Thread

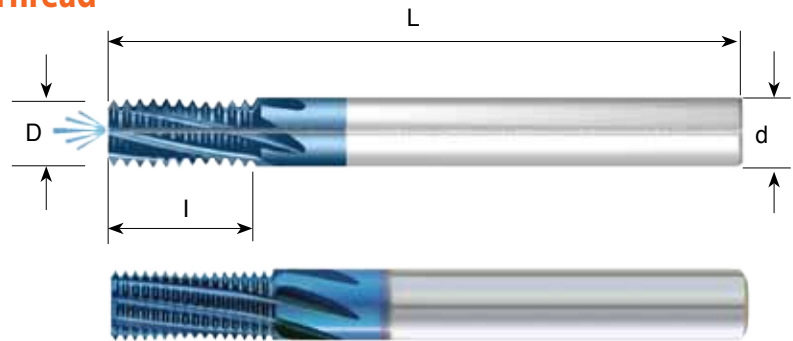

Pitch TPI	Standard	Ordering Code	d mm	D	Flutes	I	L
28	G1/8	FMT 08078 H14 28W	8	.307	8	.56	2.5
19	G1/4-3/8	FMT 1010 G16 19W	10	.394	7	.66	2.9
14	G1/2-7/8	FMT 1414 H26 14W	14	.551	8	1.04	3.3
11	G ≥ 1	FMT 1616 H38 11W	16	.630	8	1.50	4.1

Whitworth BSW With internal coolant through the flutes

Same Tool for Internal and External Thread - Metric Shanks

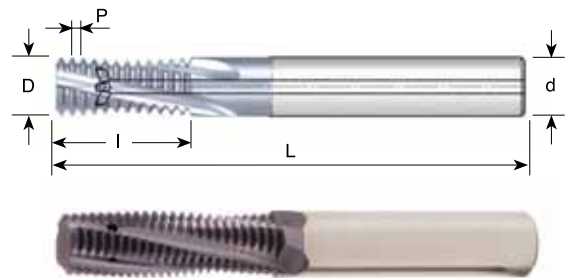
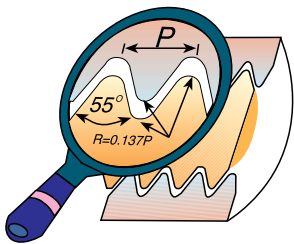

Pitch TPI	Standard	Ordering Code	d mm	D	No. of Flutes	I	L
* 20	1/4	MTZ06046C12 20W	6	.181	3	.48	2.3
18	5/16	MTZ06053C14 18W	6	.209	3	.58	2.3
16	3/8	MTZ08068C16 16W	8	.268	3	.66	2.5
16	1/2	MTZ10092D24 16W	10	.362	4	.97	2.9
14	7/16	MTZ08078D20 14W	8	.307	4	.82	2.5
12	1/2	MTZ10086D24 12W	10	.339	4	.96	2.9
11	5/8	MTZ12109D28 11W	12	.429	4	1.14	3.3

Order example: MTZ 08064C16 16 W MT7

* Cutter without coolant

UN

Tools for Internal Thread

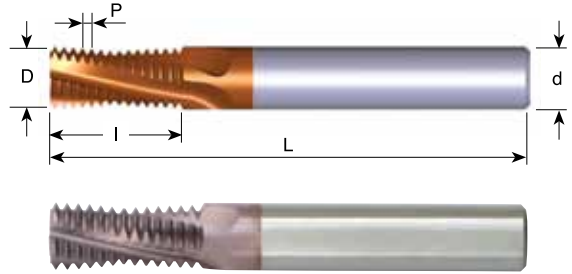
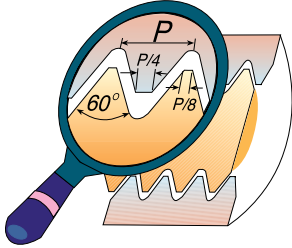

Pitch TPI	UNC	UNF	UNEF	Ordering Code	d	D	No. of Flutes	I	L
40	5			MT0250C02 40UN	1/4	.098	3	.24	2.5
32	8	10	12	MT0250C02 32UN	1/4	.126	3	.27	2.5
28		1/4		MT0250C04 28UN	1/4	.157	3	.45	2.5
28			7/16-1/2	MT0250C05 28UN	1/4	.236	3	.57	2.5
24		5/16		MT0250C06 24UN	1/4	.197	3	.56	2.5
24		3/8	9/16-5/8	MT0312C08 24UN	5/16	.276	3	.81	2.5
20	1/4			MT0250C05 20UN	1/4	.177	3	.48	2.5
20		7/16-1/2		MT0312C08 20UN	5/16	.276	3	.83	2.5
20			3/4-1	MT0500E11 20UN	1/2	.472	5	1.08	3.5
18	5/16			MT0250C06 18UN	1/4	.197	3	.58	2.5
18		9/16-5/8	1 1/8-1 5/8	MT0375D10 18UN	3/8	.375	4	1.03	3.0
16	3/8			MT0250C07 16UN	1/4	.236	3	.66	2.5
16		3/4		MT0500D12 16UN	1/2	.472	4	1.22	3.5
14	7/16			MT0312C08 14UN	5/16	.276	3	.82	2.5
14		7/8		MT0625E15 14UN	5/8	.591	5	1.46	4.0
13	1/2			MT0312C09 13UN	5/16	.313	3	.88	2.5
12	9/16			MT0375C10 12UN	3/8	.375	3	1.04	3.0
12		1-1 1/2		MT0625E16 12UN	5/8	.625	5	1.63	4.0
11	5/8			MT0375C11 11UN	3/8	.375	3	1.14	3.0
10	3/4			MT0500C14 10UN	1/2	.472	3	1.35	3.5
9	7/8			MT0625C15 9UN	5/8	.591	3	1.50	4.0
8	1			MT0625C17 8UN	5/8	.625	3	1.69	4.0
7	1 1/8-1 1/4			MT0750D17 7UN	3/4	.750	4	1.78	4.0

Order example: MT 0625E15 14 UN MT7

For thread mills with coolant bore see following pages

For small thread mills see pages 264-266, 271 & 286.



UN With internal coolant bore

Tools for Internal Thread

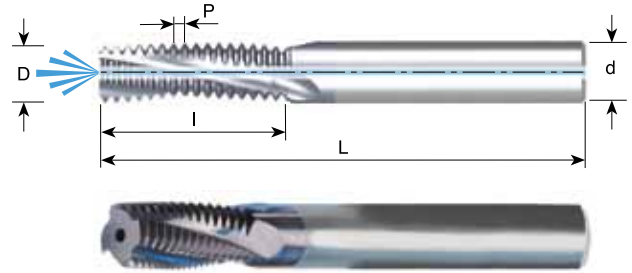
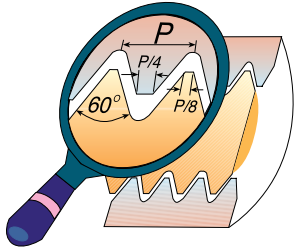

Pitch TPI	UNC	UNF	UNEF	Ordering Code	d	D	No. of Flutes	I	L
32	8	10	12	MTB0250C02 32 UN	1/4	.126	3	.27	2.5
32			5/16	MTB0250C05 32 UN	1/4	.250	3	.58	2.5
32			3/8	MTB0312D07 32 UN	5/16	.312	4	.74	2.5
28		1/4		MTB0250C04 28 UN	1/4	.197	3	.44	2.5
28			7/16-1/2	MTB0250C05 28 UN	1/4	.250	3	.56	2.5
24		5/16		MTB0312C05 24 UN	5/16	.260	3	.56	2.5
24		3/8	9/16-5/8	MTB0312D08 24 UN	5/16	.312	4	.81	2.5
20	1/4			MTB0250C04 20 UN	1/4	.185	3	.48	2.5
20		7/16		MTB0312C08 20 UN	5/16	.312	3	.83	2.5
20		1/2		MTB0375D08 20 UN	3/8	.375	4	.88	3.0
20			3/4-1	MTB0500E10 20 UN	1/2	.500	5	1.07	4.0
18	5/16			MTB0250C05 18 UN	1/4	.220	3	.58	2.5
18		9/16-5/8	1 ^{1/8} -1 ^{5/8}	MTB0500D10 18 UN	1/2	.445	4	1.03	4.0
16	3/8			MTB0312C06 16 UN	5/16	.264	3	.66	2.5
16		3/4		MTB0500D12 16 UN	1/2	.500	4	1.22	4.0
14	7/16			MTB0312C08 14 UN	5/16	.303	3	.82	2.5
14		7/8		MTB0625E14 14 UN	5/8	.625	5	1.46	4.0
13	1/2			MTB0375C08 13 UN	3/8	.362	3	.89	3.0
12	9/16			MTB0500C10 12 UN	1/2	.413	3	1.04	4.0
12		1-1 ^{1/2}		MTB0625E16 12 UN	5/8	.625	5	1.63	4.0
11	5/8			MTB0500C11 11 UN	1/2	.449	3	1.14	4.0
10	3/4			MTB0625D13 10 UN	5/8	.567	4	1.35	4.0
9	7/8			MTB0625C15 9 UN	5/8	.625	3	1.50	4.0
8	1			MTB0750D16 8 UN	3/4	.750	4	1.69	4.0
7	1 ^{1/8} -1 ^{1/4}			MTB0750D17 7 UN	3/4	.750	4	1.78	4.0

Order example: MTB 0625E14 14 UN MT7

For thread mills with coolant through the flutes see next page

For small thread mills see pages 264-266, 271 & 286. 

UN With internal coolant through the flutes

Tools for Internal Thread - Metric Shank

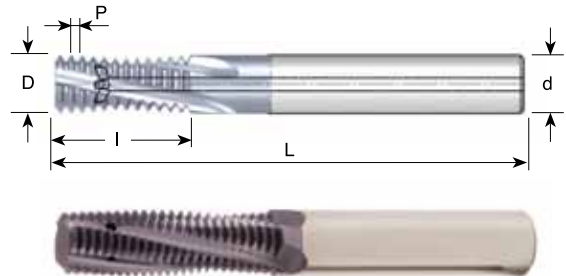
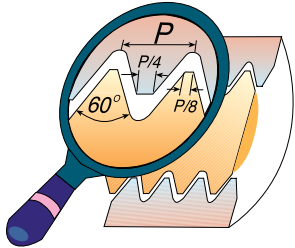

Pitch TPI	UNC	UNF	UNEF	Ordering Code	d mm	D	No. of Flutes	I	L
28		1/4		MTZ0605C11 28 UN	6	.197	3	.44	2.3
28			7/16-1/2	MTZ0606C14 28 UN	6	.236	3	.56	2.3
24		5/16		MTZ08066C14 24 UN	8	.260	3	.56	2.5
24		3/8	9/16-5/8	MTZ0808D21 24 UN	8	.315	4	.81	2.5
20		7/16		MTZ0808C21 20 UN	8	.315	3	.83	2.5
20		1/2		MTZ1010D22 20 UN	10	.394	4	.88	2.9
20			3/4-1	MTZ1212E27 20 UN	12	.472	5	1.07	3.3
18	5/16			MTZ06056C14 18 UN	6	.220	3	.58	2.3
18		9/16-5/8	1 ^{1/8} -1 ^{5/8}	MTZ12113D26 18 UN	12	.445	4	1.03	3.3
16	3/8			MTZ08067C16 16 UN	8	.264	3	.66	2.5
16		3/4		MTZ1212D31 16 UN	12	.472	4	1.22	3.3
14	7/16			MTZ08077C20 14 UN	8	.303	3	.82	2.5
14		7/8		MTZ1616E37 14 UN	16	.630	5	1.46	4.0
13	1/2			MTZ10092C22 13 UN	10	.362	3	.89	2.9
12	9/16			MTZ12105C26 12 UN	12	.413	3	1.04	3.3
11	5/8			MTZ12114C28 11 UN	12	.449	3	1.14	3.3
10	3/4			MTZ16144D34 10 UN	16	.567	4	1.35	4.0

Order example: MTZ 0808D21 24 UN MT7

For small thread mills see pages 264-266, 271 & 286. 

UN With relieved neck and internal coolant bore

Tools for Internal Thread - Metric Shank

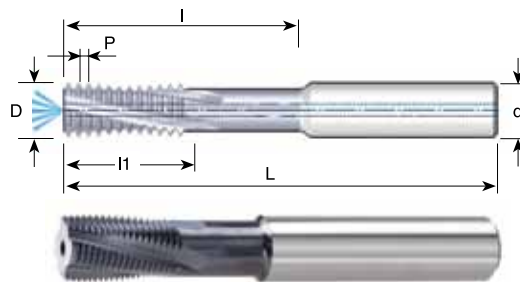
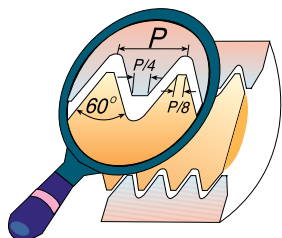

Pitch TPI	Thread size	Ordering Code	d mm	D	No. of Flutes	l1	l	L
20	$\varnothing \geq .47$	MTQ1010D30 20 UN	10	.394	4	.70	1.20	2.9
20	$\varnothing \geq .55$	MTQ1212E35 20 UN	12	.472	5	.80	1.40	3.3
20	$\varnothing \geq .71$	MTQ1616F43 20 UN	16	.630	6	1.00	1.70	4.1
18	$\varnothing \geq .59$	MTQ1212D35 18 UN	12	.472	4	.78	1.39	3.3
16	$\varnothing \geq .59$	MTQ1212D35 16 UN	12	.472	4	.81	1.38	3.3
16	$\varnothing \geq .75$	MTQ1616E42 16 UN	16	.630	5	1.00	1.69	4.1
16	$\varnothing \geq .91$	MTQ2020F58 16 UN	20	.787	6	1.44	2.31	4.1
14	$\varnothing \geq .79$	MTQ1616E45 14 UN	16	.630	5	1.00	1.78	4.1
12	$\varnothing \geq .63$	MTQ1212D42 12 UN	12	.472	4	1.00	1.67	3.3
12	$\varnothing \geq .95$	MTQ2020E55 12 UN	20	.787	5	1.33	2.17	4.1

Order example: MTQ 1212D35 16 UN MT7

For small thread mills see pages 264-266, 271 & 286. 

UN Fast MT with internal coolant bore

Tools for Internal Thread

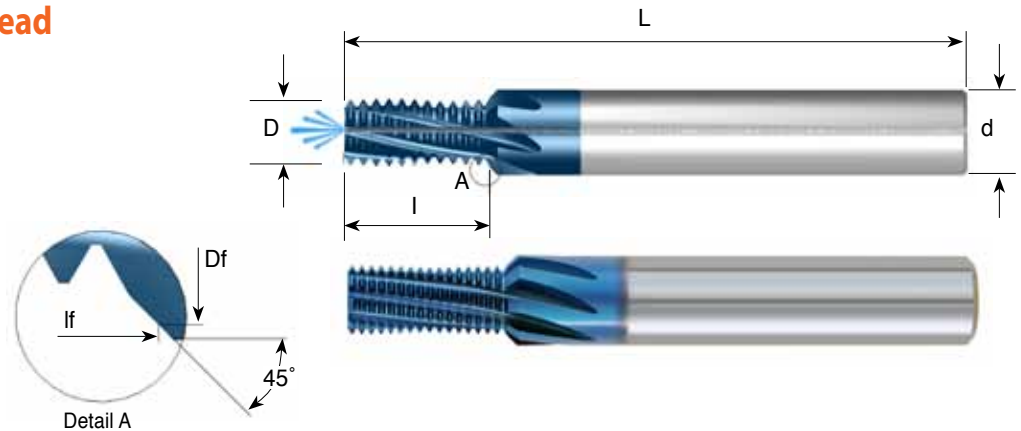

Pitch TPI	UNC	UNF	UNEF	Ordering Code	d mm	D	Df	Flutes	I	If	L
28		1/4		FMT 08052 F11 28 UN	8	.205	.283	6	.44	.48	2.5
28			7/16, 1/2	FMT 12098 H19 28 UN	12	.386	.465	8	.77	.81	3.3
24		5/16		FMT 10066 G14 24 UN	10	.260	.378	7	.56	.62	2.9
24		3/8	9/16, 5/8, 11/16	FMT 12082 G17 24 UN	12	.323	.417	7	.69	.74	3.3
20	1/4			* FMT 08048 E12 20 UN	8	.189	.268	5	.48	.52	2.5
20		7/16		FMT 12092 H21 20 UN	12	.362	.449	8	.83	.87	3.3
20		1/2	3/4, 7/8, 1	FMT 14111 H22 20 UN	14	.437	.531	8	.87	.92	3.3
18	3/8			FMT 1006 F14 18 UN	10	.236	.331	6	.58	.63	2.9
18		9/16, 5/8	1 1/16, 1 1/8	FMT 16125 H26 18 UN	16	.492	.591	8	1.03	1.08	4.1
16	3/8			FMT 10074 F16 16 UN	10	.291	.378	6	.66	.70	2.9
16		3/4		FMT 20167 H34 16 UN	20	.657	.760	8	1.34	1.39	4.1
14	7/16	7/8		FMT 12085 F20 14 UN	12	.335	.421	6	.82	.87	3.3
13	1/2			FMT 12098 F24 13 UN	12	.386	.465	6	.96	1.00	3.3
12	9/16	1		FMT 16116 F26 12 UN	16	.457	.598	6	1.04	1.11	4.1

* Without internal coolant

BSPT

Same Tool for Internal and External Thread
Metric Shank

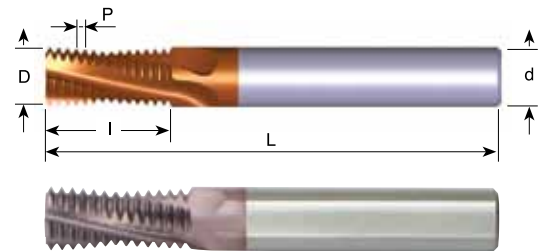
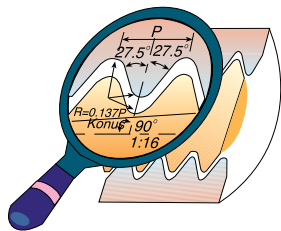

Pitch TPI	Standard	Ordering Code	d mm	D	No. of Flutes	I	L
28	RC1/8	MT0606C9 28 BSPT	6	.236	3	.38	2.3
19	RC1/4-3/8	MT0808C14 19 BSPT	8	.315	3	.55	2.5
14	RC1/2	MT1212D19 14 BSPT	12	.472	4	.75	3.3
11	RC1-2	MT1616D28 11 BSPT	16	.630	4	1.14	4.1

Order example: MT 1616D28 11 BSPT MT7

For thread mills with coolant through the flutes see next page

BSPT With internal coolant bore

Same Tool for Internal and External Thread - Metric Shank

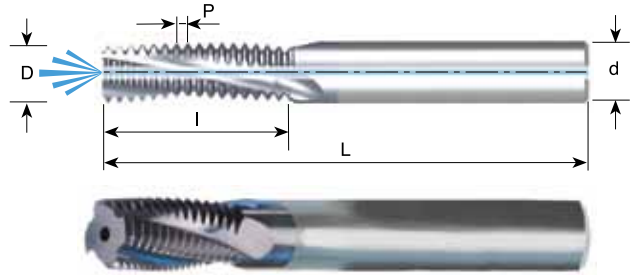
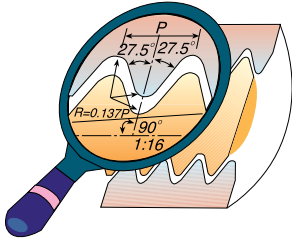

Pitch TPI	Standard	Ordering Code	d mm	D	No. of Flutes	I	L
28	RC1/8	MTB08078C14 28 BSPT	8	.307	3	.56	2.5
19	RC1/4-3/8	MTB1010D16 19 BSPT	10	.394	4	.66	2.9
14	RC1/2	MTB1616E26 14 BSPT	16	.630	5	1.04	4.1
11	RC1-2	MTB1616D28 11 BSPT	16	.630	4	1.14	4.1

Order example: MTB 08078C14 28 BSPT MT7

BSPT With internal coolant through the flutes

Same Tool for Internal and External Thread - Metric Shank

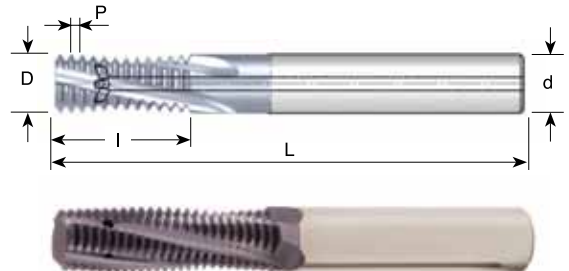
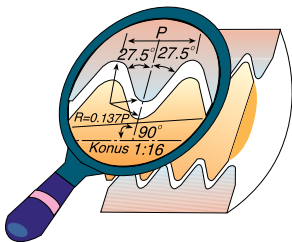

Pitch TPI	Standard	Ordering Code	d mm	D	No. of Flutes	I	L
28	RC1/8	MTZ08078C14 28 BSPT	8	.307	3	.56	2.5
19	RC1/4-3/8	MTZ1010D16 19 BSPT	10	.394	4	.66	2.9
14	RC1/2	MTZ1616E26 14 BSPT	16	.630	5	1.04	4.0
11	RC1-2	MTZ1616D28 11 BSPT	16	.630	4	1.14	4.0

Order example: MTZ 1010D16 19 BSPT MT7

For conical preparation end mills see page 253

NPT

Same Tool for Internal and External Thread

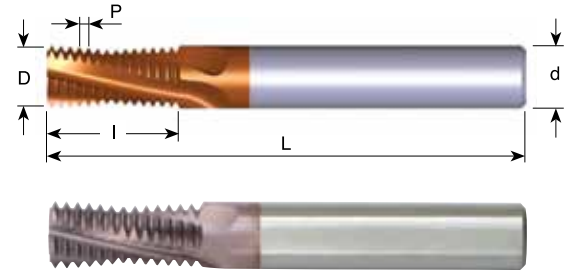
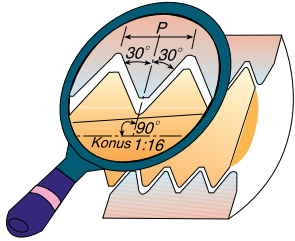

Pitch TPI	Standard	Ordering Code	d	D	No. of Flutes	I	L
27	1/16	MT0250C03 27 NPT	1/4	.230	3	.39	2.5
27	1/8	MT0250C04 27 NPT	1/4	.250	3	.39	2.5
18	1/4-3/8	MT0312C06 18 NPT	5/16	.312	3	.58	2.5
14	1/2-3/4	MT0500D08 14 NPT	1/2	.500	4	.82	3.5
11.5	1-2	MT0625D11 11.5 NPT	5/8	.625	4	1.09	4.0
8	≥ 2 1/2	MT0750D16 8 NPT	3/4	.750	4	1.56	4.0

Order example: MT 0312C06 18 NPT MT7

NPT With internal coolant

Same Tool for Internal and External Thread

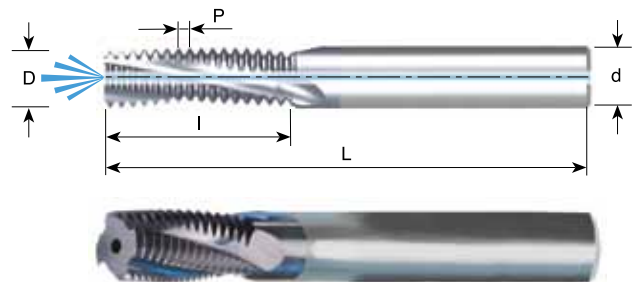

Pitch TPI	Standard	Ordering Code	d	D	No. of Flutes	I	L
27	1/8	MTB0312C04 27 NPT	5/16	.299	3	.43	2.5
18	1/4-3/8	MTB0375D06 18 NPT	3/8	.375	4	.64	3.0
14	1/2-3/4	MTB0625D08 14 NPT	5/8	.610	4	.89	4.0
11.5	1-2	MTB0750D11 11.5 NPT	3/4	.750	4	1.17	4.0
8	≥ 2 1/2	MTB0750D15 8 NPT	3/4	.750	4	1.56	4.0

Order example: MTB 0312C04 27 NPT MT7

For thread mills with coolant through the flutes see next page

For conical preparation end mills see page 253

NPT With internal coolant through the flutes

Same Tool for Internal and External Thread - Metric Shank

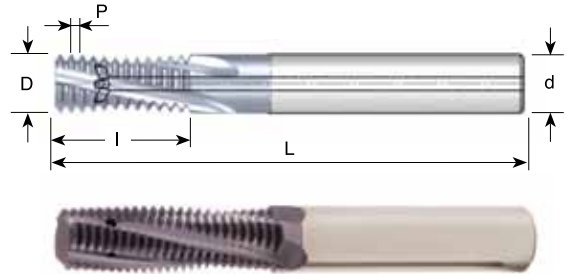
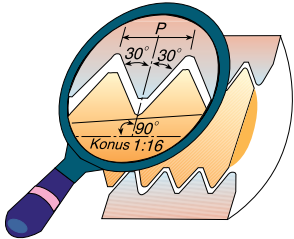

Pitch TPI	Standard	Ordering Code	d mm	D	No. of Flutes	I	L
27	1/8	MTZ08076C10 27 NPT	8	.299	3	.43	2.5
18	1/4-3/8	MTZ1010D16 18 NPT	10	.394	4	.64	2.9
14	1/2-3/4	MTZ16155D22 14 NPT	16	.610	4	.89	4.0

Order example: MTZ 08076C10 27 NPT MT7

NPTF

Same Tool for Internal and External Thread

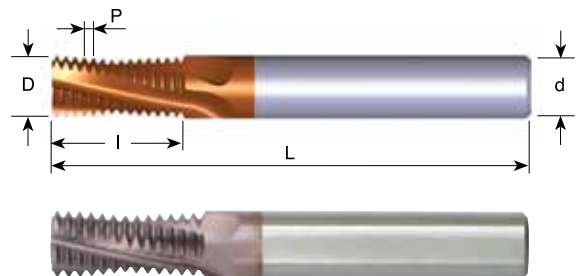
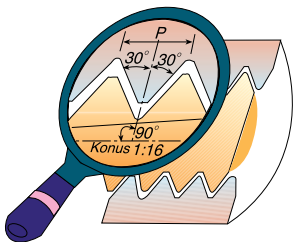

Pitch TPI	Standard	Ordering Code	d	D	No. of Flutes	I	L
27	1/16	MT0250C03 27 NPTF	1/4	.230	3	.39	2.5
27	1/8	MT0250C04 27 NPTF	1/4	.250	3	.39	2.5
18	1/4-3/8	MT0312C06 18 NPTF	5/16	.312	3	.58	2.5
14	1/2-3/4	MT0500D08 14 NPTF	1/2	.500	4	.82	3.5
11.5	1-2	MT0625D11 11.5 NPTF	5/8	.625	4	1.09	4.0
8	≥ 2 1/2	MT0750D16 8 NPTF	3/4	.750	4	1.56	4.0

Order example: MT 0500D08 14 NPTF MT7

For thread mills with coolant bore see next page
For conical preparation end mills see page 253

NPTF With internal coolant bore

Same Tool for Internal and External Thread

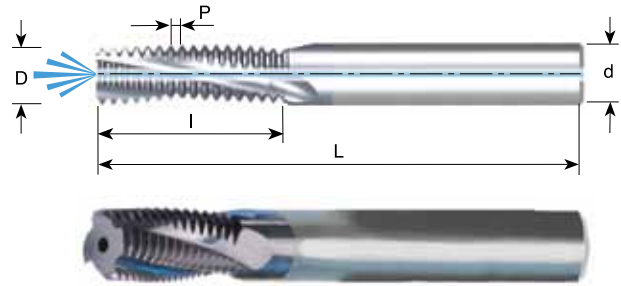
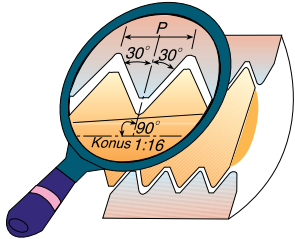

Pitch TPI	Standard	Ordering Code	d	D	No. of Flutes	I	L
27	1/8	MTB0312C04 27 NPTF	5/16	.299	3	.43	2.5
18	1/4-3/8	MTB0375D06 18 NPTF	3/8	.375	4	.64	3.0
14	1/2-3/4	MTB0625D08 14 NPTF	5/8	.610	4	.89	4.0
11.5	1-2	MTB0750D11 11.5 NPTF	3/4	.750	4	1.17	4.0
8	≥ 2 1/2	MTB0750D15 8 NPTF	3/4	.750	4	1.57	4.0

Order example: MTB 0312C04 27 NPTF MT7

NPTF With internal coolant through the flutes

Same Tool for Internal and External Thread - Metric Shank

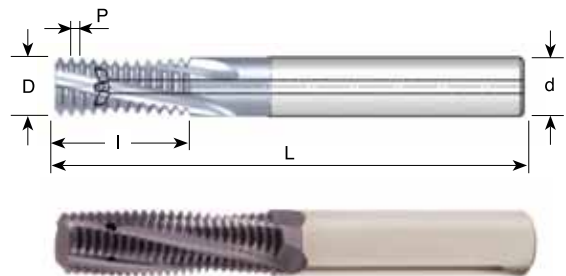
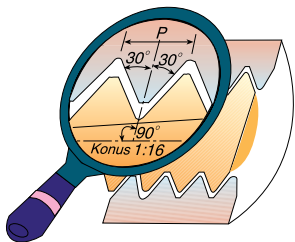

Pitch TPI	Standard	Ordering Code	d mm	D	No. of Flutes	I	L
27	1/8	MTZ08076C10 27 NPTF	8	.299	3	.43	2.5
18	1/4-3/8	MTZ1010D16 18 NPTF	10	.394	4	.64	2.9
14	1/2-3/4	MTZ16155D22 14 NPTF	16	.610	4	.89	4.0

Order example: MTZ 1010D16 18 NPTF MT7

For conical preparation end mills see page 253

Solid Carbide Tapered End Mills

Solid carbide tapered end mills are used for milling preparation of conical threads before the thread milling operation.

Advantages:

- Increases the tool life of mill thread cutters and indexable inserts.
- Equal and uniform load along the cutting edge of the mill thread cutter.
- Shorter machining time during the mill thread operation, due to the tapered preparation.

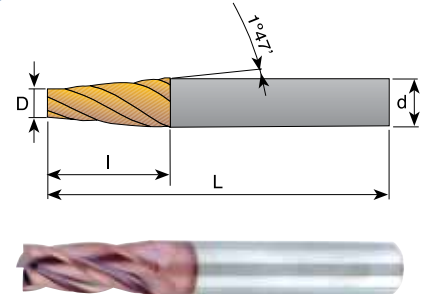

Ordering Code	d	D	I	L	No. of Flutes	Size
SC0652D12	6 mm	.20	.47	2.3	4	NPT 1/16" - 1/8" NPTF 1/16" - 1/8" BSPT 1/16" - 1/8"
SC0375D09	3/8	.32	.95	3	4	NPT 1/8" - 1" NPTF 1/8" - 1" BSPT 1/8" - 1"
SC0500D12	1/2	.42	1.26	3.5	4	NPT 1/4" - 3" NPTF 1/4" - 3" BSPT 1/4" - 3"

Order example: SC 0500D12 MT7
Carbide grade: MT7

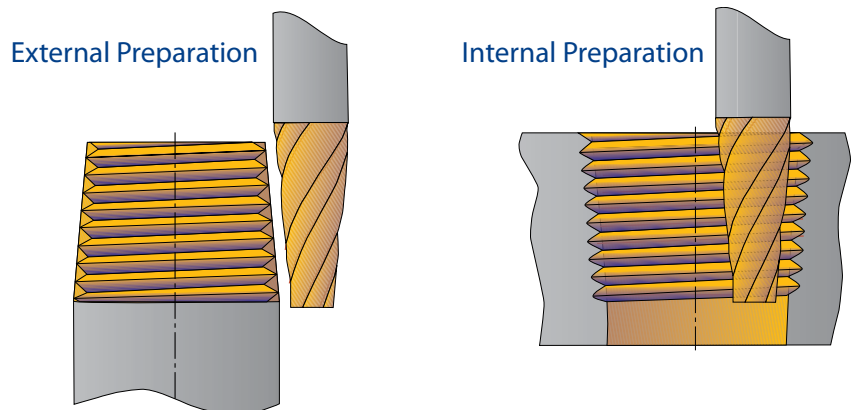

NPS With internal coolant bore

Same Tool for Internal and External Thread

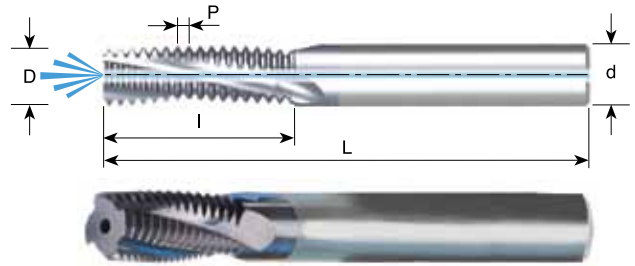
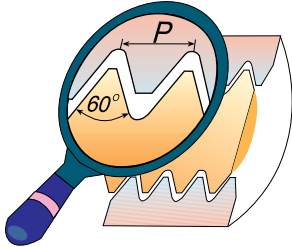

Pitch TPI	Standard	Ordering Code	d	D	No. of Flutes	I	L
27	1/8	MTB0312C04 27 NPS	5/16	.299	3	.43	2.5
18	1/4-3/8	MTB0375D06 18 NPS	3/8	.375	4	.64	3.0
14	1/2-3/4	MTB0625D08 14 NPS	5/8	.610	4	.89	4.0
11.5	1-2	MTB0750D11 11.5 NPS	3/4	.750	4	1.17	4.0

Order example: MTB 0375D06 18 NPS MT7

NPSF With internal coolant bore

Same Tool for Internal and External Thread

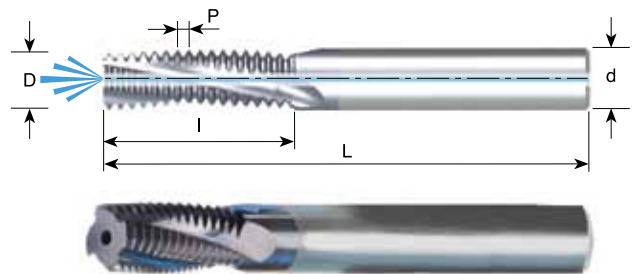
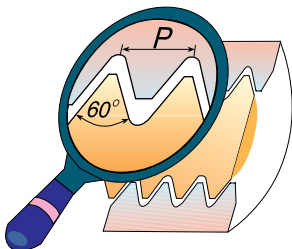

Pitch TPI	Standard	Ordering Code	d	D	No. of Flutes	I	L
27	1/8	MTB0312C04 27 NPSF	5/16	.299	3	.43	2.5
18	1/4-3/8	MTB0375D06 18 NPSF	3/8	.375	4	.64	3.0
14	1/2-3/4	MTB0625D08 14 NPSF	5/8	.610	4	.89	4.0
11.5	1-2	MTB0750D11 11.5 NPSF	3/4	.750	4	1.17	4.0

Order example: MTB 0312C04 27 NPSF MT7

PG DIN 40430 - With internal coolant bore

Same Tool for Internal and External Thread - Metric Shank

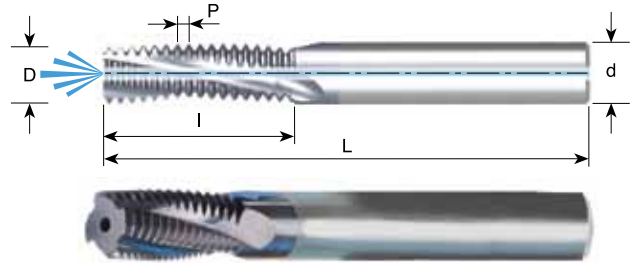
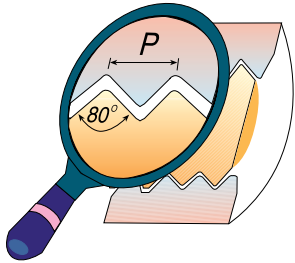

Pitch TPI	Standard	Ordering Code	d mm	D	No. of Flutes	I	L
20	Pg 7	MTB1010D19 20 PG	10	.394	4	.78	2.9
18	Pg 9, 11, 13.5, 16	MTB1212D20 18 PG	12	.472	4	.81	3.3
16	Pg 21, 29, 36, 42, 48	MTB1212D23 16 PG	12	.472	4	.91	3.3

Order example: MTB 1212 D20 18 PG MT7

Mill - Thread Solid Carbide for External Threads

Advantages:

- Excellent surface finish thanks to the spiral flutes
- Short machining time due to multi 3 to 5 flutes

ISO

Metric Shank

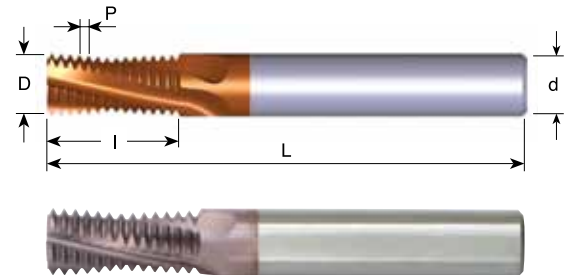
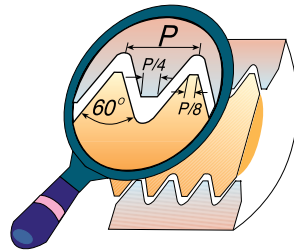

Pitch mm	Ordering Code	d mm	D	No. of Flutes	I	L
1.0	EMT1010D16 1.0 ISO	10	.394	4	.65	2.9
1.0	EMT1212E20 1.0 ISO	12	.472	5	.81	3.3
1.25	EMT1010D16 1.25 ISO	10	.394	4	.67	2.9
1.5	EMT1010D15 1.5 ISO	10	.394	4	.62	2.9
1.5	EMT1212D20 1.5 ISO	12	.472	4	.80	3.3
1.75	EMT1212D20 1.75 ISO	12	.472	4	.79	3.3
2.0	EMT1010C17 2.0 ISO	10	.394	3	.67	2.9
2.0	EMT1212D21 2.0 ISO	12	.472	4	.83	3.3

Order example: EMT 1010D15 1.5 ISO MT7

UN

Metric Shank

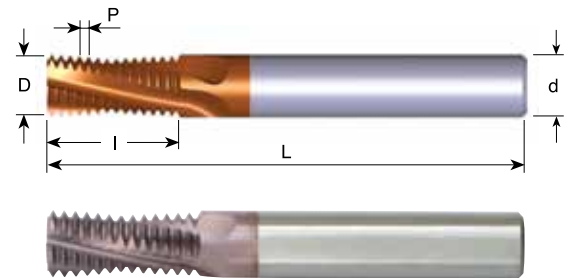
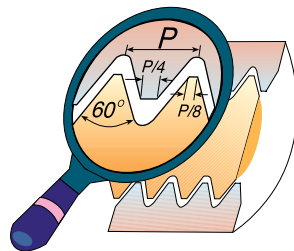

Pitch TPI	Ordering Code	d mm	D	No. of Flutes	I	L
24	EMT1010D16 24 UN	10	.394	4	.65	2.9
20	EMT1212E21 20 UN	12	.472	5	.83	3.3
18	EMT1212D20 18 UN	12	.472	4	.81	3.3
16	EMT1212D21 16 UN	12	.472	4	.84	3.3
14	EMT1212D20 14 UN	12	.472	4	.82	3.3
12	EMT1212D20 12 UN	12	.472	4	.79	3.3

Order example: EMT 1212D20 18 UN MT7

MJ - ISO 5855

Metric Shank

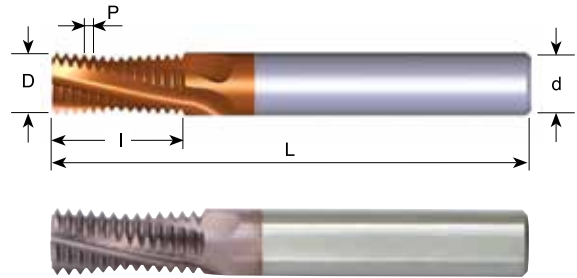
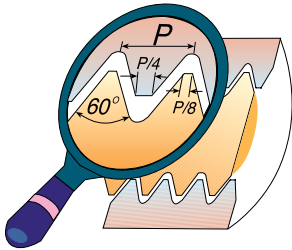

Grade	P	M	K	N	S	H
MT7	●	●	●	○	●	≤ 50 HRc

Pitch mm	Ordering Code	d mm	D	No. of Flutes	I	L
1.0	EMT1010D20 1.0 MJ	10	.394	4	.81	2.8
1.0	EMT1212E24 1.0 MJ	12	.472	5	.96	3.3
1.5	EMT1010D21 1.5 MJ	10	.394	4	.86	2.8
1.5	EMT1212D26 1.5 MJ	12	.472	4	1.04	3.3
2.0	EMT1010C21 2.0 MJ	10	.394	3	.83	2.8
2.0	EMT1212D27 2.0 MJ	12	.472	4	1.06	3.3

Order example: EMT 1010D15 1.5 ISO MT7

UNJ UNJC, UNJF, UNJEF, UNJS

Metric Shank

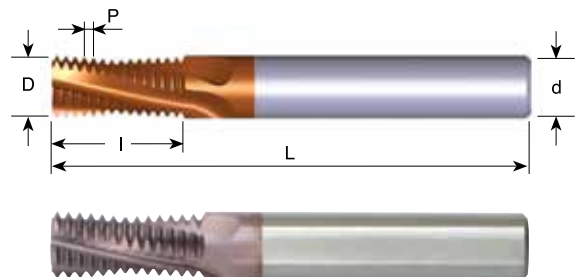
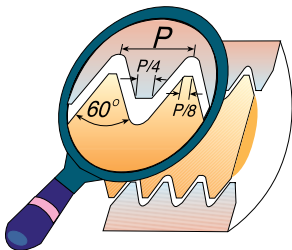

Grade	P	M	K	N	S	H
MT7	●	●	●	○	●	≤ 50 HRc

Pitch mm	Ordering Code	d mm	D	No. of Flutes	I	L
32	EMT0606C13 32 UNJ	6	.236	3	.55	2.2
28	EMT0808D17 28 UNJ	8	.315	4	.70	2.5
24	EMT1010D20 24 UNJ	10	.394	4	.81	2.8
20	EMT1212E27 20 UNJ	12	.472	5	1.07	3.3
18	EMT1212D26 18 UNJ	12	.472	4	1.03	3.3
16	EMT1212D26 16 UNJ	12	.472	4	1.03	3.3
14	EMT1212D26 14 UNJ	12	.472	4	1.04	3.3
12	EMT1212D26 12 UNJ	12	.472	4	1.04	3.3

Order example: EMT 1010D15 1.5 ISO MT7

● First choice ○ Alternative

AMT Solid Carbide Thread Mills for Aluminum Machining

Carmex introduces a new line of solid carbide thread mills for High-speed Aluminum machining.

High-speed aluminum machining requires tools that minimize the tendency of Aluminum to stick to the tool cutting edges, provides high surface finish, ensuring efficient chip evacuation and sufficient strength of the cutting edge to absorb the cutting forces.

Features

- Optimized carbide grade for Aluminum, cast iron and stainless steels
- Cylindrical shank (Weldon shank- upon request)
- With internal coolant bore
- Uncoated, smooth cutting edge
- High thread surface quality
- Same tool for right hand or left hand internal threads
- Additional items with cutting chamfer

Carbide grade: K20 (K10 - K30)

Uncoated Carbide grade for non ferrous metals, aluminum and cast iron.

ISO With internal coolant bore Tools for Internal thread - Metric Shanks

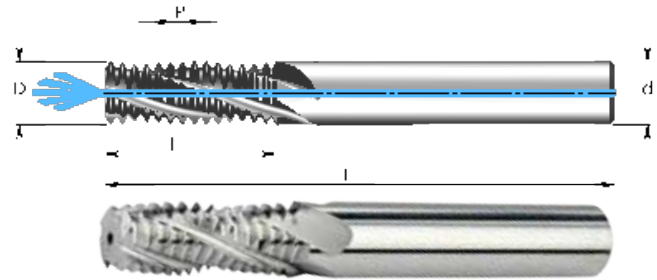
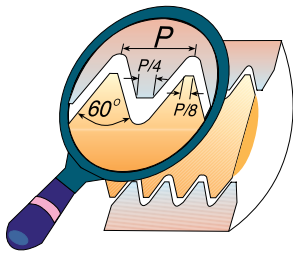

Thread length: 2xD

Grade	P	M	K	N	S	H
K20	○	○	●	●	●	

Pitch mm	M coarse	M fine	Ordering Code	d mm	D	No. of Flutes	I	L
0.5	M3	M4	* AMT 03024C6 0.5 ISO	3	.094	3	.268	1.5
0.5		M5	AMT 06043C10 0.5 ISO	6	.169	3	.425	2.3
0.7	M4		AMT 06031C8 0.7 ISO	6	.122	3	.346	2.3
0.75		M6	AMT 0605C13 0.75 ISO	6	.197	3	.516	2.3
0.8	M5		AMT 0604C10 0.8 ISO	6	.157	3	.425	2.3
1.0	M6		AMT 06048C13 1.0 ISO	6	.189	3	.531	2.3
1.0		M10	AMT 0808D21 1.0 ISO	8	.315	4	.846	2.5
1.25	M8	M10	AMT 08064C16 1.25 ISO	8	.252	3	.665	2.5
1.5	M10		AMT 0808C21 1.5 ISO	8	.315	3	.858	2.5
1.5		M14	AMT 12112D29 1.5 ISO	12	.441	4	1.154	3.3
1.75	M12		AMT 10095D25 1.75 ISO	10	.374	4	1.000	2.9
2.0	M16	M17	AMT14126D35 2.0 ISO	14	.496	4	1.378	3.3

* Without internal coolant

ISO With internal coolant bore and cutting Chamfer

Tools for Internal thread - Metric Shanks

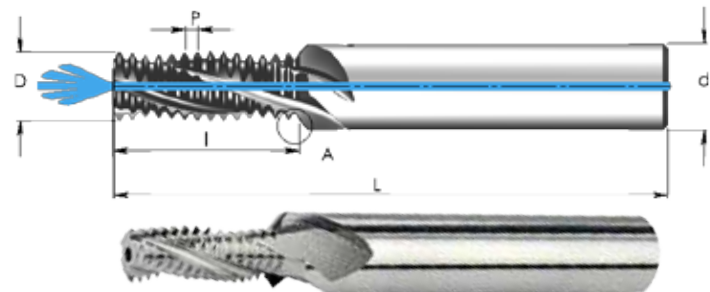
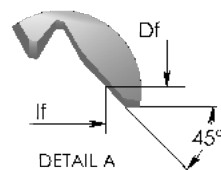

Thread length: 2xD

Grade	P	M	K	N	S	H
K20	○	○	●	●	●	

Pitch mm	M coarse	M fine	Ordering Code	d mm	D	Df	No. of Flutes	I	If	L
0.8	M5		AMT 0604C10 0.8 ISO-C	6	.157	.209	3	.425	.453	2.3
1.0	M6		AMT 08048C13 1.0 ISO-C	8	.189	.252	3	.531	.563	2.5
1.25	M8	M10	AMT 10064C16 1.25ISO-C	10	.252	.327	3	.665	.705	2.9
1.5	M10		AMT 1208C21 1.5 ISO-C	12	.315	.409	3	.858	.906	3.3

● First choice ○ Alternative

UN With internal coolant bore

Tools for Internal thread - Metric Shanks

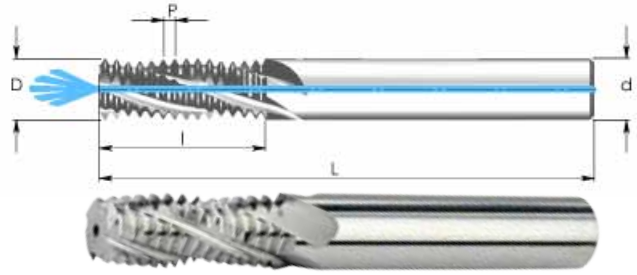
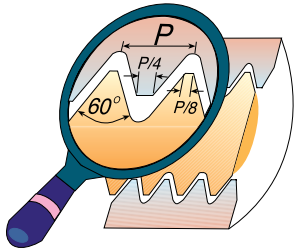

Thread length: 2xD

Grade	P	M	K	N	S	H
K20	○	○	●	●	●	

Pitch TPI	UNC	UNF	UNEF	Ordering Code	d mm	D	No. of Flutes	I	L
32	8	10	12	AMT 06032C9 32 UN	6	.126	3	.358	2.3
28		1/4		AMT 06052C14 28 UN	6	.205	3	.551	2.3
24		3/8	9/16-5/8	AMT 0808D20 24 UN	8	.315	4	.811	2.5
20	1/4			AMT 06048C14 20 UN	6	.189	3	.575	2.3
20		7/16		AMT 10092C23 20 UN	10	.362	3	.925	2.9
18	5/16			AMT 0606C17 18 UN	6	.236	3	.693	2.3
18		9/16-5/8	1 1/8 - 1 5/8	AMT 1212D30 18 UN	12	.472	4	1.193	3.3
16	3/8			AMT 08074C21 16 UN	8	.291	3	.843	2.5
16		3/4		AMT 1616E38 16 UN	16	.630	5	1.531	4.1

UN With internal coolant bore and cutting Chamfer

Tools for Internal thread

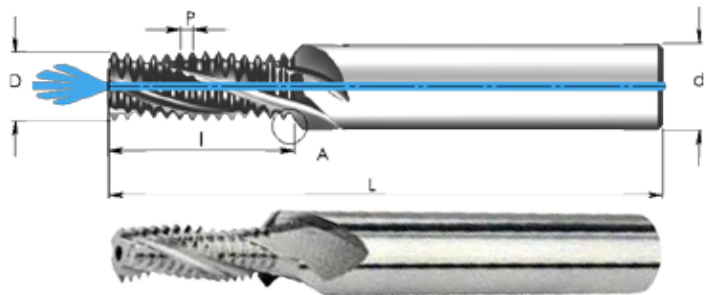
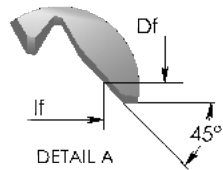

Thread length: 2xD

Grade	P	M	K	N	S	H
K20	○	○	●	●	●	

Pitch TPI	UNC	UNF	UNEF	Ordering Code	d mm	D	Df	No. of Flutes	I	If	L
20	1/4			AMT 08048C14 20 UN-C	8	.189	.268	3	.575	.614	2.5
18	5/16			AMT 1006C17 18 UN-C	10	.236	.331	3	.693	.740	2.9
16	3/8			AMT 12074C21 16 UN-C	12	.291	.394	3	.843	.894	3.3

● First choice ○ Alternative

Mini Mill-Thread



MTS

- Threading from ISO M1 x 0.25 and 0-80UN.
- Working in high cutting speed.
- Short machining time.
- Low cutting forces thanks to the short profile.
- No broken taps.
- Machining of hardened materials up to 45 HRc.

Carbide grade: MT7

Sub-Micron grade with Titanium Aluminum Nitride multi-layer coating (ISO K10 - K20). To be run at medium to high cutting speeds. General purpose for all materials

MTI - For threading deep parts

Carbide grade: MT8 Sub-micron grade with advanced PVD triple coating (ISO K10-K20). Extremely high heat resistant and smooth cutting operation, for high performance, and normal machining conditions. General purpose for all materials.

MT11 Ultra-fine Sub-micron grade with advanced PVD triple blue coating

Advantages

- Enables machining in deep holes.
- Same tool can produce a wide range of threads and pitches.
- Same tool can produce both External and Internal threads.
- Coolant through the flutes is very effective for deep holes.
- Spiral flutes allow smooth cutting action.
- Shorter machining time due to multi (3 to 5) flutes.
- Longer tool life due to special triple coating.

Contents:	Page:	Contents:	Page:
Product Identification	262	UN	271
MTS		MTI	
ISO	263-264	Partial Profile 60°	272
UN	265-266	Partial Profile 60° - with Internal Coolant through the flutes	272
G55°	267	Partial Profile 55°	273
UNJ - with Internal Coolant through the flutes	268	ISO	274
MJ - with Internal Coolant through the flutes	268	UN	274
MTSB		Trapez	275
ISO	270	Acme	276

Product Identification

Mini Mill-Thread MTS Ordering Codes

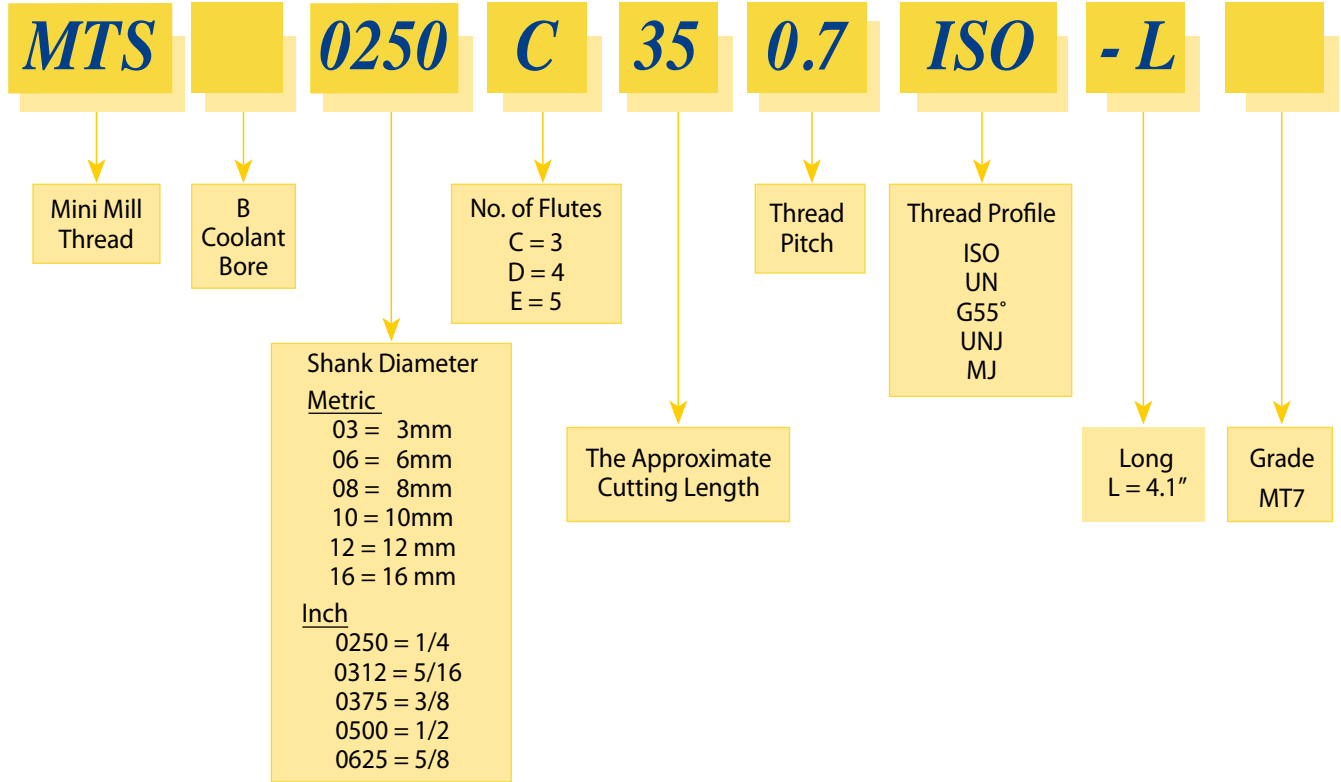

Mini Mill-Thread MTI Ordering Codes

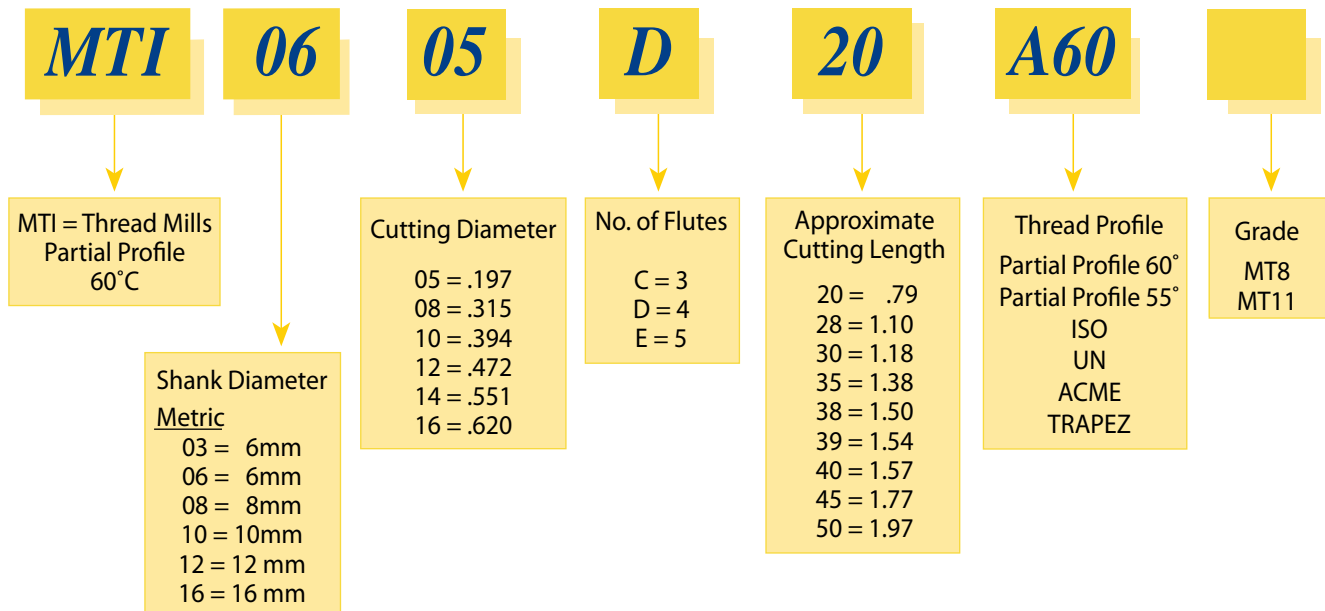

ISO

Tools for Internal Thread

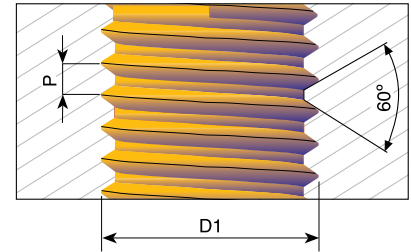

Pitch mm	M coarse	M fine	Ordering Code	d	D	No. of Flutes	I	L	Thread depth
0.25	M1		MTS03007C2 0.25 ISO	3 mm	.028	3	.10	1.5	2.5xD1
0.25	M1.2	M1.4	MTS03009C3 0.25 ISO	3 mm	.035	3	.12	1.5	2xD1
0.3	M1.4		MTS03011C4 0.3 ISO	3 mm	.041	3	.16	1.5	3xD1
0.35	M1.6	M2	MTS03012C5 0.35 ISO	3 mm	.047	3	.19	1.5	3xD1
	M1.6	M2	MTS06012C5 0.35 ISO-L	6 mm	.047	3	.19	4.1	3xD1
0.35		M5, M6	MTS06045D14 0.35 ISO	6 mm	.177	4	.57	2.3	3xD1
0.4	M2		MTS0250C18 0.4 ISO	1/4	.060	3	.18	2.5	2xD1
	M2		MTS06016C4 0.4 ISO-L	6 mm	.060	3	.18	4.1	2xD1
	M2		MTS03016C6 0.4 ISO	3 mm	.060	3	.24	1.5	3xD1
	M2		MTS03016C10 0.4 ISO	3 mm	.060	3	.41	1.5	5xD1
0.45	M2.2		MTS0250C20 0.45 ISO	1/4	.065	3	.20	2.5	2xD1
	M2.2		MTS03017C7 0.45 ISO	3 mm	.065	3	.28	1.5	3xD1
0.45	M2.5		MTS0250C22 0.45 ISO	1/4	.077	3	.22	2.5	2xD1
	M2.5		MTS0602C5 0.45 ISO-L	6 mm	.077	3	.22	4.1	2xD1
	M2.5		MTS0250C30 0.45 ISO	1/4	.077	3	.30	2.5	3xD1
	M2.5		MTS0602C8 0.45 ISO-L	6 mm	.077	3	.31	4.1	3xD1
	M2.5		MTS0302C10 0.45 ISO	3 mm	.077	3	.41	1.5	4xD1
0.5	M3		MTS0250C26 0.5 ISO	1/4	.093	3	.26	2.5	2xD1
	M3		MTS06024C6 0.5 ISO-L	6 mm	.093	3	.26	4.1	2xD1
	M3		MTS0250C37 0.5 ISO	1/4	.093	3	.37	2.5	3xD1
	M3		MTS06024C9 0.5 ISO-L	6 mm	.093	3	.37	4.1	3xD1
	M3		MTS03024C12 0.5 ISO	3 mm	.094	3	.49	1.5	4xD1
	M3		MTS03024C15 0.5 ISO	3 mm	.094	3	.61	1.5	5xD1
0.5		M4, M5	MTS06034D08 0.5 ISO	6 mm	.134	4	.33	2.3	2xD1
		M4, M5	MTS06034D012 0.5 ISO	6 mm	.134	4	.49	2.3	3xD1
0.5		M6, M7	MTS06054D20 0.5 ISO	6 mm	.211	4	.79	2.3	3xD1
0.6		M3.5	MTS0250C30 0.6 ISO	1/4	.108	3	.30	2.5	2xD1
		M3.5	MTS06028C10 0.6 ISO	6 mm	.108	3	.41	2.3	3xD1
0.7	M4		MTS0250C35 0.7 ISO	1/4	.122	3	.35	2.5	2xD1
	M4		MTS0250C49 0.7 ISO	1/4	.122	3	.49	2.5	3xD1
	M4		MTS06031C12 0.7 ISO-L	6 mm	.122	3	.49	4.1	3xD1
	M4		MTS06031C16 0.7 ISO	6 mm	.122	3	.66	2.3	4xD1
0.75	M4.5	M5	MTS06034C9 0.75 ISO	6 mm	.134	3	.39	2.3	2xD1
		M6	MTS06049D12 0.75 ISO	6 mm	.193	4	.50	2.3	2xD1
		M10, M12	MTS0808D25 0.75 ISO	8 mm	.315	4	.98	2.5	2.5xD1
0.8	M5		MTS0250C49 0.8 ISO	1/4	.150	3	.49	2.5	2xD1
	M5		MTS0250C63 0.8 ISO	1/4	.150	3	.63	2.5	3xD1
	M5		MTS06038C16 0.8 ISO-L	6 mm	.150	3	.63	4.1	3xD1
	M5		MTS0604C20 0.8 ISO	6 mm	.157	3	.82	2.3	4xD1

Order example: MTS 0250 C26 0.5 ISO MT7

ISO Tools for Internal Thread

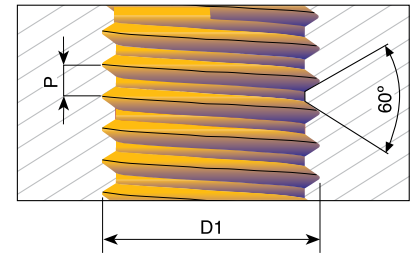

Pitch mm	M coarse	M fine	Ordering Code	d	D	No. of Flutes	I	L	Thread depth
1.0	M6	M8	MTS0250C55 1.0 ISO	1/4	.183	3	.55	2.5	2xD1
	M6	M8	MTS0250C79 1.0 ISO	1/4	.183	3	.79	2.5	3xD1
	M6	M8	MTS06047C20 1.0 ISO-L	6 mm	.183	3	.79	4.1	3xD1
	M6	M8	MTS06048C25 1.0 ISO	6 mm	.189	3	.98	2.3	4xD1
1.0		M10, M12	MTS0808D31 1.0 ISO	8 mm	.315	4	1.22	2.5	3xD1
1.25	M8	M10, M12	MTS0250C71 1.25 ISO	1/4	.236	3	.71	2.5	2xD1
	M8	M10, M12	MTS0250C94 1.25 ISO	1/4	.236	3	.94	2.5	3xD1
	M8	M10, M12	MTS0606C24 1.25 ISO-L	6 mm	.236	3	.94	4.1	3xD1
	M8	M10, M12	MTS08064C33 1.25 ISO	8 mm	.252	3	1.32	2.5	4xD1
1.5	M10	M14, M16	MTS0312C91 1.5 ISO	5/16	.307	3	.91	2.5	2xD1
	M10	M14, M16	MTS08078C31 1.5 ISO	8 mm	.307	3	1.24	2.5	3xD1
	M10	M14, M16	MTS08078C31 1.5 ISO-L	8 mm	.307	3	1.24	4.1	3xD1
	M10	M14, M16	MTS0808C41 1.5 ISO	8 mm	.315	3	1.63	3.1	4xD1
1.75	M12		MTS0375C10 1.75 ISO	3/8	.354	3	1.02	3.0	2xD1
	M12		MTS1009C37 1.75 ISO	10 mm	.354	3	1.49	2.9	3xD1
2.0	M14	M17	MTS1010D30 2.0 ISO	10 mm	.394	4	1.18	2.9	2xD1
	M16	M18, M20	MTS0500D13 2.0 ISO	1/2	.465	4	1.38	3.5	2xD1
	M16	M18, M20	MTS12118D50 2.0 ISO	12 mm	.465	4	1.97	4.1	3xD1
2.5	M20		MTS0625E16 2.5 ISO	5/8	.591	5	1.69	4.0	2xD1

- Machining Titanium, surgical stainless steels and hardened materials up to 45 HRC.
- Suitable for high speed air turbine machines (30,000-40,000 RPM) and for standard machining centers (6,000 RPM and higher).
- Can also be used for general purpose threading.

Order example: MTS 03024C12 0.5 ISO MT7

UN

Tools for Internal Thread

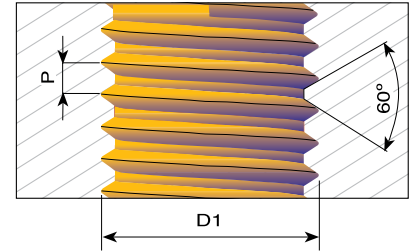

Pitch TPI	UNC	UNF	Ordering Code	d	D	No. of Flutes	l	L	Thread depth
80		0	MTS0250C16 80 UN	1/4	.045	3	.16	2.5	3xD1
		0	MTS03012C8 80 UN	3 mm	.045	3	.31	1.5	5xD1
72		1	MTS0250C15 72 UN	1/4	.057	3	.15	2.5	2xD1
		1	MTS03015C6 72 UN	3 mm	.057	3	.24	1.5	3xD1
64	1	2	MTS0250C15 64 UN	1/4	.055	3	.15	2.5	2xD1
56	2	3	MTS03016C4 56 UN	3 mm	.065	3	.17	1.5	2xD1
	2	3	MTS0250C17 56 UN	1/4	.065	3	.17	2.5	2xD1
	2	3	MTS03016C6 56 UN	3 mm	.065	3	.26	1.5	3xD1
	2	3	MTS0250C26 56 UN	1/4	.065	3	.26	2.5	3xD1
	2	3	MTS06016C6 56 UN-L	6 mm	.065	3	.26	4.1	3xD1
	2	3	MTS03016C9 56 UN	3 mm	.065	3	.36	1.5	4xD1
48	3	4	MTS03016C11 56 UN	3 mm	.065	3	.45	1.5	5xD1
	3	4	MTS0250C20 48 UN	1/4	.075	3	.20	2.5	2xD1
40	4		MTS0250C25 40 UN	1/4	.083	3	.25	2.5	2xD1
	4		MTS06021C6 40 UN-L	6 mm	.083	3	.25	4.1	2xD1
	4		MTS03021C8 40 UN	3 mm	.083	3	.31	1.5	3xD1
	4		MTS0250C31 40 UN	1/4	.083	3	.31	2.5	3xD1
	4		MTS06021C8 40 UN-L	6 mm	.083	3	.31	4.1	3xD1
	4		MTS03021C12 40 UN	3 mm	.083	3	.47	1.5	4xD1
40	5	6	MTS0250C28 40 UN	1/4	.096	3	.28	2.5	2xD1
	5	6	MTS0250C38 40 UN	1/4	.096	3	.38	2.5	3xD1
36		8	MTS0250C35 36 UN	1/4	.130	3	.35	2.5	2xD1
32	6		MTS0250C28 32 UN	1/4	.100	3	.28	2.5	2xD1
	6		MTS06025C7 32 UN-L	6 mm	.100	3	.28	4.1	2xD1
	6		MTS03025C10 32 UN	3 mm	.100	3	.41	1.5	3xD1
	6		MTS0250C40 32 UN	1/4	.100	3	.41	2.5	3xD1
	6		MTS06025C10 32 UN-L	6 mm	.100	3	.41	4.1	3xD1
	6		MTS03025C14 32 UN	3 mm	.100	3	.58	1.5	4xD1
32	8		MTS0250C37 32 UN	1/4	.126	3	.37	2.5	2xD1
	8		MTS06032C9 32 UN-L	6 mm	.126	3	.37	4.1	2xD1
	8		MTS0250C49 32 UN	1/4	.126	3	.49	2.5	3xD1
	8		MTS06032C12 32 UN-L	6 mm	.126	3	.49	4.1	3xD1
	8		MTS06032C17 32 UN	6 mm	.126	3	.69	2.3	4xD1
32		10	MTS0250C41 32 UN	1/4	.146	3	.41	2.5	2xD1
		10	MTS0250C59 32 UN	1/4	.146	3	.59	2.5	3xD1
		10	MTS06037C15 32 UN-L	6	.146	3	.59	4.1	3xD1
		10	MTS06037C20 32 UN	6	.146	3	.79	2.3	4xD1

Order example: MTS 0250C28 40 UN MT7

UN

Tools for Internal Thread

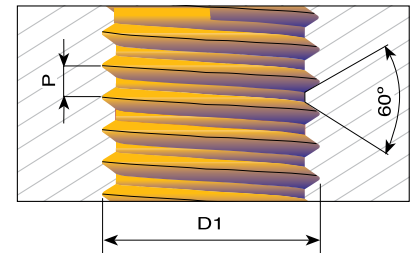

Pitch TPI	UNC	UNF	Ordering Code	d	D	No. of Flutes	l	L	Thread depth
28		12	MTS0250C43 28 UN	1/4	.165	3	.43	2.5	2xD1
28		1/4	MTS0250C57 28 UN	1/4	.197	3	.57	2.5	2xD1
		1/4	MTS0250C75 28 UN	1/4	.197	3	.75	2.5	3xD1
		1/4	MTS0605C19 28 UN-L	6 mm	.197	3	.75	4.1	3xD1
24	10, 12		MTS0250C42 24 UN	1/4	.138	3	.42	2.5	2xD1
	10, 12		MTS06035C15 24 UN	6 mm	.138	3	.61	2.3	3xD1
24		5/16, 3/8	MTS0312C67 24 UN	5/16	.260	3	.67	2.5	2xD1
		5/16, 3/8	MTS0312C94 24 UN	5/16	.260	3	.94	2.5	3xD1
20	1/4		MTS0250C55 20 UN	1/4	.187	3	.55	2.5	2xD1
	1/4		MTS06047C14 20 UN-L	6 mm	.187	3	.55	4.1	2xD1
	1/4		MTS0250C75 20 UN	1/4	.187	3	.75	2.5	3xD1
	1/4		MTS06047C19 20 UN-L	6 mm	.187	3	.75	4.1	3xD1
20		7/16	MTS0312C98 20 UN	5/16	.312	3	.98	2.5	2xD1
		7/16	MTS0808C34 20 UN	8 mm	.315	3	1.36	2.5	3xD1
18	5/16		MTS0250C67 18 UN	1/4	.236	3	.67	2.5	2xD1
	5/16		MTS0250C91 18 UN	1/4	.236	3	.91	2.5	3xD1
18		5/8	MTS0500D14 18 UN	1/2	.500	4	1.38	3.5	2xD1
		5/8	MTS1212D49 18 UN	12 mm	.472	4	1.93	4.1	3xD1
16	3/8		MTS0312C87 16 UN	5/16	.264	3	.87	2.5	2xD1
	3/8		MTS08067C30 16 UN	8 mm	.264	3	1.19	2.5	3xD1
14	7/16		MTS0312C98 14 UN	5/16	.303	3	.98	2.5	2xD1
	7/16		MTS08077C35 14 UN	8 mm	.303	3	1.39	2.5	3xD1
13	1/2		MTS0375C10 13 UN	3/8	.362	3	1.08	3.0	2xD1
	1/2		MTS10092C40 13 UN	10 mm	.362	3	1.58	2.9	3xD1
12	9/16		MTS0500C12 12 UN	1/2	.413	3	1.24	3.5	2xD1
	9/16		MTS12105C45 12 UN	12 mm	.413	3	1.77	4.1	3xD1
11	5/8		MTS0500C13 11 UN	1/2	.449	3	1.36	3.5	2xD1
	5/8		MTS12114C50 11 UN	12 mm	.449	3	1.97	4.1	3xD1
10	3/4		MTS16144D41 10 UN	5/8	.567	4	1.63	4.0	2xD1
	3/4		MTS16144D59 10 UN	16 mm	.567	4	2.35	4.1	3xD1

Order example: MTS 0250C26 56UN MT7

*Specially designed for the production of dental implants

- Machining Titanium, surgical stainless steels and hardened materials up to 45 HRC.
- Suitable for high speed air turbine machines (30,000-40,000 RPM) and for standard machining centers (6,000 RPM and higher).
- Can also be used for general purpose threading.

G 55° BSW, BSP

Same Tool for Internal and External Thread - Metric Shanks

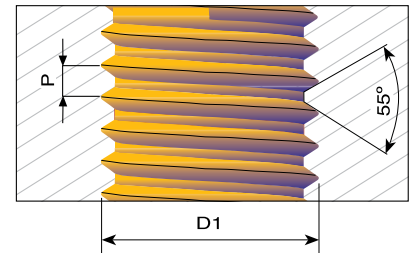

For thread depth up to 2 x D1

Pitch TPI	Standard	Ordering Code	d mm	D	No. of Flutes	I	L
28	G 1/8	MTS08078C19 28 W	8	.307	3	0.77	2.5
19	G 1/4 - 3/8	MTS1010D30 19 W	10	.393	4	1.18	2.9
14	G 1/2 - 7/8	MTS1212D37 14 W	12	.472	4	1.46	3.3
11	G ≥ 1	MTS1616D44 11 W	16	.630	4	1.73	4.1

Order example: MTS 1212D37 14 W MT7

UNJ With internal coolant through the flutes

Tools for Internal Thread - Metric Shanks

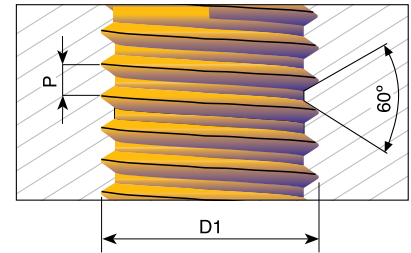
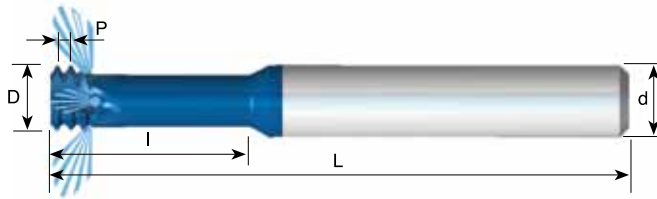

For thread depth up to 2.5 x D1

Pitch TPI	UNJC	UNJF	Ordering Code	d mm	D	No. of Flutes	l	L
* 32	6		MTS06025C7 32 UNJ	6	.100	3	.28	2.3
* 32	8	10	MTS06033C10 32 UNJ	6	.130	3	.41	2.3
28		1/4	MTS08051C16 28 UNJ	8	.201	3	.63	2.5
24		5/16, 3/8	MTS08067C20 24 UNJ	8	.264	3	.79	2.5
* 20	1/4		MTS06049C16 20 UNJ	6	.193	3	.63	2.3
20		7/16	MTS0808C28 20 UNJ	8	.315	3	1.10	2.5
18	5/16		MTS08061C20 18 UNJ	8	.242	3	.79	2.5
16	3/8		MTS08069C24 16 UNJ	8	.272	3	.94	2.5
14	7/16		MTS08079C25 14 UNJ	8	.311	3	.98	2.5
13	1/2		MTS10094C27 13 UNJ	10	.370	3	1.08	2.9

* Cutters without coolant

Order example: MTS 06049C16 20 UNJ MT8

Carbide grade MT8 Sub Micron grade with advanced PVD triple coating (ISO K 10-K20). Extremely high heat resistant and smooth cutting operation, for high performance, and normal machining conditions. General purpose for all materials

MJ With internal coolant through the flutes

Tools for Internal Thread - Metric Shanks

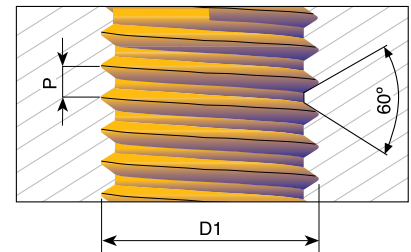
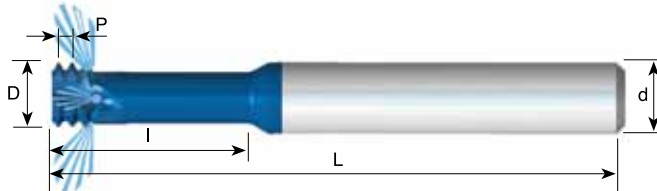

For thread depth up to 2.5 x D1

Pitch TPI	D1	Ordering Code	d mm	D	No. of Flutes	l	L
* 0.7	MJ4	MTS06032C10 0.7 MJ	6	.126	3	.39	2.3
* 0.8	MJ5	MTS06039C12 0.8 MJ	6	.154	3	.49	2.3
* 1.0	MJ6	MTS06048C15 1.0 MJ	6	.189	3	.59	2.3
1.25	MJ8	MTS08061C20 1.25 MJ	8	.240	3	.79	2.5
1.5	MJ10	MTS0808C25 1.5 MJ	8	.315	3	.98	2.5
1.75	MJ12	MTS10092C30 1.75 MJ	10	.362	3	1.18	2.9
2.0	MJ14, MJ16	MTS1010C35 2.0 MJ	10	.394	3	1.38	2.9

* Cutters without coolant

Order example: MTS 06048C15 1.0 MJ MT8

Carbide grade MT8 Sub Micron grade with advanced PVD triple coating (ISO K 10-K20). Extremely high heat resistant and smooth cutting operation, for high performance, and normal machining conditions. General purpose for all materials

MTSB

Carmex has developed a new innovative solid carbide thread milling cutters **MTSB** type with internal coolant **Bore**.

The coolant bores provides high coolant pressure through the tool into the application pre-hole, and washes the chips away.

High pressure coolant extends tool life.

Also the coolant liquid cools the tool cutting edge very efficient.

Excellent solution for:

- Small and deep threads.
- Thread milling operation on horizontal machining centers, where chips are concentrated at the bottom of the thread and external coolant can't wash the chips away.
- Complicated applications where external coolant is inefficient or can't reach the machined area.
- In certain cases the tool collet is close to the application pre-hole and blocks the external coolant.

Can be also used on any other thread milling operation (blind or through hole) require improved performance with highest thread quality.

Features:

- Increased number of flutes for high performance, shorter cycle time and improved tool life.
- Working at high machining parameters (increasing productivity).
- Advance PVD triple coating.
- Threads size: M1.2 up to M8
0-80 up to 12-24UNC

Carbide grade: MT7

Sub-Micron grade with advance PVD triple coating.

Extremely high heat resistance and smooth cutting operation, for high performance and normal machining conditions.

ISO

Tools for Internal Thread

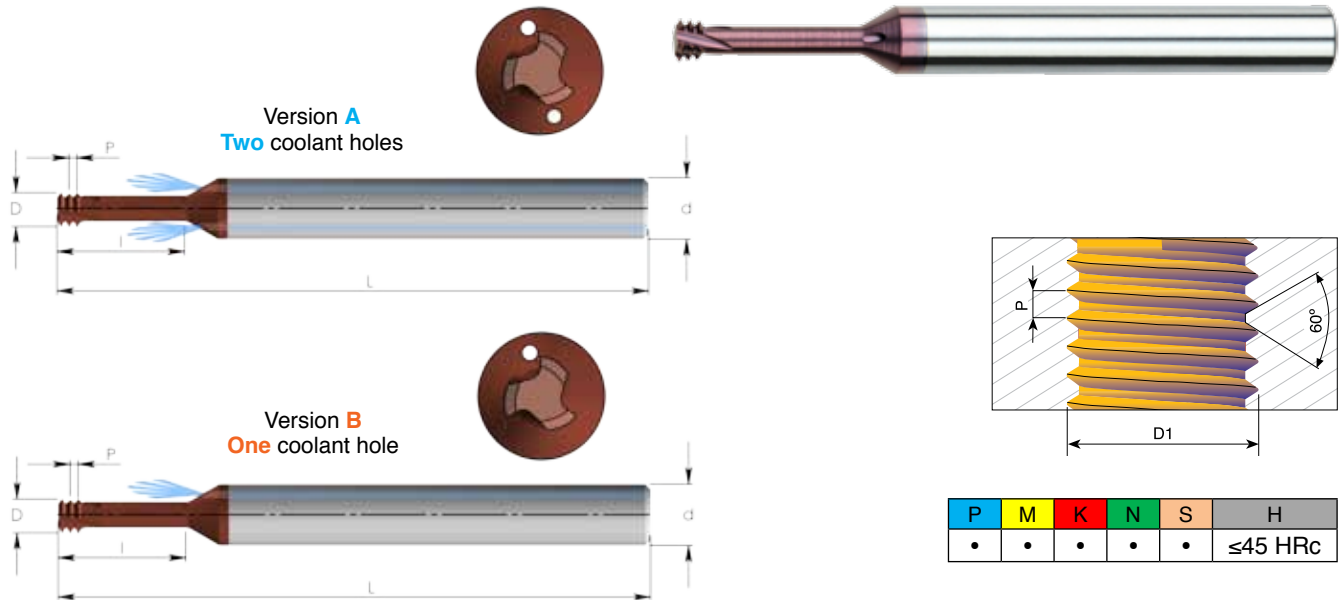

Pitch mm	M coarse	M Fine	Ordering Code	d mm	D	No. of Flutes	I	L	Thread depth	Version
0.25	M1.2	M1.4	MTSB 06009 C2 0.25 ISO	6	.035	3	.11	2.3	2xD1	A
0.3	M1.4		MTSB 06011 C4 0.3 ISO	6	.041	3	.18	2.3	3xD1	A
0.35	M1.6	M2	MTSB 06012 C5 0.35 ISO	6	.047	3	.20	2.3	3xD1	A
0.4	M2		MTSB 06016 C4 0.4 ISO	6	.061	3	.17	2.3	2xD1	A
0.4	M2		MTSB 06016 C6 0.4 ISO	6	.061	3	.25	2.3	3xD1	A
0.45	M2.5		MTSB 0602 D5 0.45 ISO	6	.077	4	.22	2.3	2xD1	A
0.45	M2.5		MTSB 0602 D7 0.45 ISO	6	.077	4	.31	2.3	3xD1	A
0.5	M3		MTSB 06024 D6 0.5 ISO	6	.094	4	.26	2.3	2xD1	A
0.5	M3		MTSB 06024 D9 0.5 ISO	6	.094	4	.37	2.3	3xD1	A
0.6	M3.5		MTSB 06028 D7 0.6 ISO	6	.110	4	.30	2.3	2xD1	A
0.7	M4		MTSB 06032 D8 0.7 ISO	6	.126	4	.34	2.3	2xD1	B
0.7	M4		MTSB 06032 D12 0.7 ISO	6	.126	4	.50	2.3	3xD1	B
0.8	M5		MTSB 06038 D10 0.8 ISO	6	.150	4	.43	2.3	2xD1	B
0.8	M5		MTSB 06038 D15 0.8 ISO	6	.150	4	.62	2.3	3xD1	B
1.0	M6	M8	MTSB 08048 D13 1.0 ISO	8	.189	4	.51	2.5	2xD1	B
1.0	M6	M8	MTSB 08048 D19 1.0 ISO	8	.189	4	.75	2.5	3xD1	B

Order example: MTSB 06012 C5 0.35 ISO MT7

UN

Tools for Internal Thread

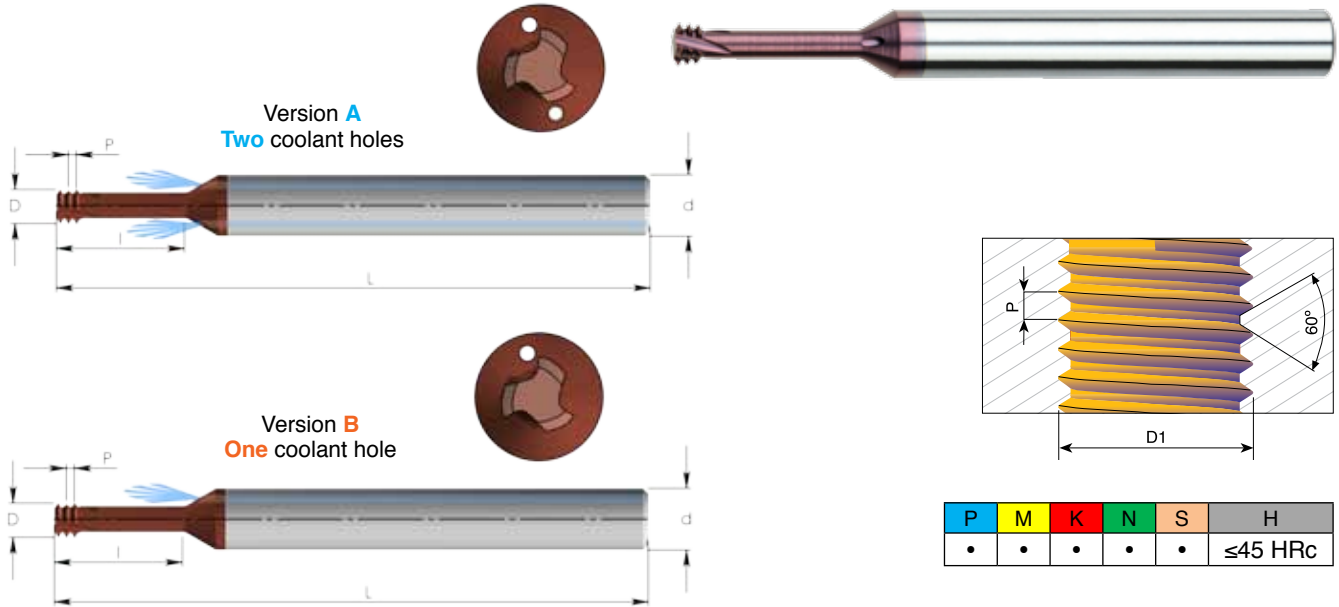

Pitch TPI	UNC	UNF	Ordering Code	d mm	D	No. of Flutes	l	L	Thread depth	Version
80		0	MTSB 06012 C4 80 UN	6	.045	3	.19	2.3	3xD1	A
72		1	MTSB 06014 C5 72 UN	6	.057	3	.23	2.3	3xD1	A
56	2	3	MTSB 06016 C4 56 UN	6	.065	3	.19	2.3	2xD1	A
56	2	3	MTSB 06016 C7 56 UN	6	.065	3	.28	2.3	3xD1	A
48	3	4	MTSB 06019 D5 48 UN	6	.075	4	.22	2.3	2xD1	A
40	4		MTSB 06021 D6 40 UN	6	.083	4	.25	2.3	2xD1	A
40	4		MTSB 06021 D9 40 UN	6	.083	4	.36	2.3	3xD1	A
40	4		MTSB 06021 D12 40 UN	6	.083	4	.47	2.3	4xD1	A
40	5	6	MTSB 06024 D7 40 UN	6	.096	4	.28	2.3	2xD1	A
32	6		MTSB 06025 D7 32 UN	6	.100	4	.31	2.3	2xD1	A
32	6		MTSB 06025 D11 32 UN	6	.100	4	.44	2.3	3xD1	A
32	8		MTSB 06032 D9 32 UN	6	.126	4	.36	2.3	2xD1	B
32	8		MTSB 06032 D13 32 UN	6	.126	4	.52	2.3	3xD1	B
32		10	MTSB 06037 D10 32 UN	6	.146	4	.41	2.3	2xD1	B
32		10	MTSB 06037 D15 32 UN	6	.146	4	.60	2.3	3xD1	B
24	10, 12		MTSB 06035 D10 24 UN	6	.138	4	.42	2.3	2xD1	B
24	10, 12		MTSB 06035 D15 24 UN	6	.138	4	.61	2.3	3xD1	B

Order example: MTSB 06016 C4 56 UN MT7

Partial Profile 60° Same Tool for Internal and External Thread Metric Shanks

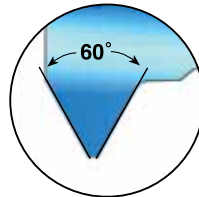

Detail A

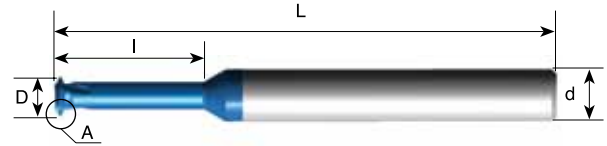

Pitch mm	Pitch TPI	Ordering Code	M Coarse	M Fine	UN, UNC, UNS UNF, UNEF	d mm	D	No. of Flutes	I	L
0.25-0.35	100-72	MTI03012C3 A60	M1.6 x 0.35	M1.6 x 0.25 M1.8 x 0.25 M2.0 x 0.25	0-80 UNF	3	.045	3	.12	1.5
0.35-0.45	72-56	MTI03014C4 A60	M2 x 0.4 M2.2 x 0.45	M2 x 0.35 M2.2 x 0.35	1-64 UNC, 1-72 UNF, 2-56 UNC, 2-64 UNF	3	.055	3	.15	1.5
0.35-0.6	72-40	MTI03019C5 A60	M2.5 x 0.45	M2.5 x 0.35 M3 x 0.35	3-84 UNC, 3-56 UNF, 4-40 UNC, 4-48 UNF	3	.075	3	.20	1.5
0.5 -0.8	48-32	MTI03024C7 A60	M3 x 0.5 M3.5 x 0.6	M3.5 x 0.5	5-40 UNC, 5-44 UNF, 6-32 UNC, 6-40 UNF	3	.096	3	.28	1.5
0.5 -1.0	48-24	MTI06032C9 A60	M4 x 0.7 M4.5 x 0.75	M4 x 0.5	8-32 UNC, 8-36 UNF, 10-24 UNC, 10-28 UNS, 10-32 UNF	6	.126	3	.37	2.3
0.5 -1.0	48-24	MTI0604C12 A60	M5 x 0.8 M6 x 1.0	M5 x 0.5 M5.5 x 0.5 M5 x 0.75	10-36 UNS, 10-40 UNS, 10-48 UNS, 12-24 UNC, 12-28 UNF	6	.157	3	.49	2.3

Order example: MTI 03024C7 A60 MT11

Carbide grade: MT11 Ultra-fine Sub-micron grade with PVD triple Blue coating

Partial Profile 60° With internal coolant through the flutes Same Tool for Internal and External Thread Metric Shanks

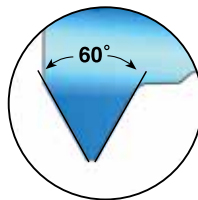

Detail A

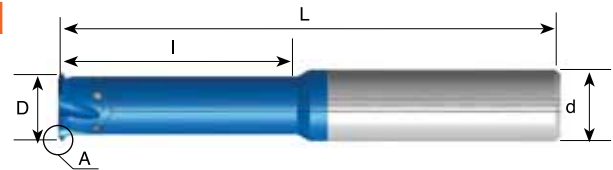

For threading deep parts

Pitch mm	Pitch TPI	Thread Dia. (mm)	Ordering Code	d mm	D	No. of Flutes	I	L
Int. 0.5 - 0.8 Ex. 0.4 - 0.8	56-28 64-32	ø ≥ 6	MTI0605D20 A60	6	.197	4	.79	2.3
		ø ≥ 9	MTI0808D28 A60	8	.315	4	1.10	2.5
		ø ≥ 13	MTI1212E38 A60	12	.472	5	1.50	3.3
Int. 1.0 - 1.75 Ex. 0.8 - 1.5	28-14 32-16	ø ≥ 10	MTI0808D30 A60	8	.315	4	1.18	2.5
		ø ≥ 12	MTI1010D35 A60	10	.394	4	1.38	2.9
		ø ≥ 14	MTI1212E39 A60	12	.472	5	1.54	3.3
		ø ≥ 16	MTI1212E40 A60	12	.472	5	1.57	3.3
Int. 2.0 - 3.0 Ex. 1.75-2.5	13- 8 15-10	ø ≥ 18	MTI1614E45 A60	16	.551	5	1.77	4.0
		ø ≥ 20	MTI1616E50 A60	16	.630	5	1.97	4.0

Order example: MTI 0808D28 A60 MT8

Carbide grade: MT8 With triple Blue coating

Partial Profile 55°

Same Tool for Internal and External Thread - Metric Shanks

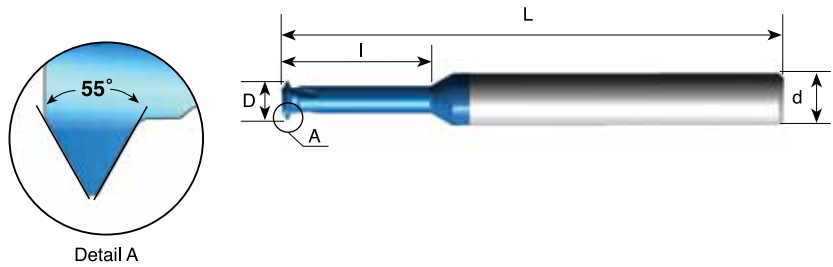

Pitch TPI	Ordering Code	d mm	D	No. of Flutes	l	L
40-32	MTI03023C7 A55	3	.089	3	.28	1.5
28-20	MTI06044C14 A55	6	.171	3	.55	2.3
28-18	MTI06059C20 A55	6	.230	3	.81	2.3
20-14	MTI0807C23 A55	8	.276	3	.91	2.5

Order example: MTI 06044C14A55 MT11

Carbide grade: MT11 Ultra-fine Sub-micron grade with PVD triple Blue coating

ISO

Tools for Internal Thread Metric Shanks

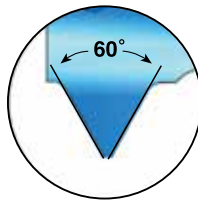

Detail A

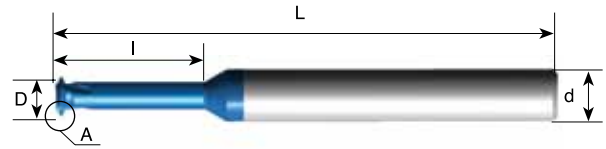

For thread depth up to 3.5 x D1

Pitch mm	M Coarse	M Fine	Ordering Code	d mm	D	No. of Flutes	l	L
0.25	M1 x 0.25		MTI03007C3 0.25 ISO	3	.028	3	.14	1.5
0.25	M1.2 x 0.25	M1.4 x 0.25 M1.6 x 0.25	MTI03009C4 0.25 ISO	3	.035	3	.17	1.5
0.3	M1.4 x 0.3		MTI03011C5 0.3 ISO	3	.041	3	.20	1.5
0.35	M1.6 x 0.35	M2 x 0.35 M2.2 x 0.35	MTI03012C6 0.35 ISO	3	.047	3	.22	1.5
0.4	M2 x 0.4		MTI03016C7 0.4 ISO	3	.061	3	.28	1.5
0.5	M3 x 0.5	M3.5 x 0.5 M4 x 0.5	MTI03024C10 0.5 ISO	3	.093	3	.42	1.5

Order example: MTI 03012C6 0.35 ISO MT11

Carbide grade: MT11 Ultra-fine Sub-micron grade with PVD triple Blue coating

UN

Tools for Internal Thread Metric Shanks

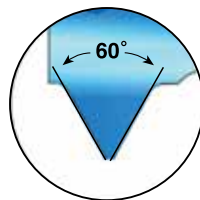

Detail A

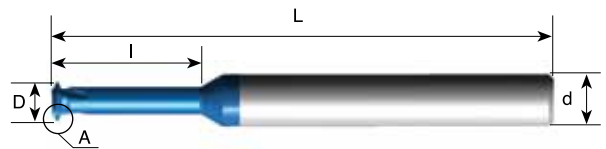

For thread depth up to 3.5 x D1

Pitch TPI	UNC	UNF	Ordering Code	d mm	D	No. of Flutes	l	L
80		0	MTI03012C5 80 UN	3	.045	3	.22	1.5
72		1	MTI03015C7 72 UN	3	.057	3	.26	1.5
56	2	3	MTI03016C9 56 UN	3	.065	3	.35	1.5
40	4		MTI03021C10 40 UN	3	.083	3	.40	1.5

Order example: MTI 03016C9 56 UN MT11

Carbide grade: MT11 Ultra-fine Sub-micron grade with PVD triple Blue coating

Trapez-DIN 103

Tools for Internal Thread

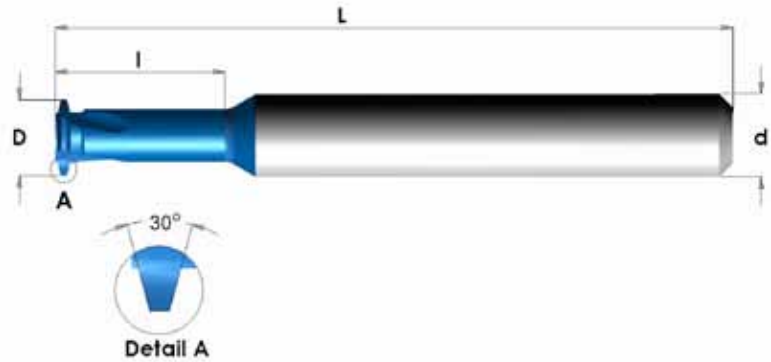

For thread depth up to 2 x D1

Pitch mm	Thread size	Ordering Code	d mm	D	No. of Flutes	l	L
1.5	Tr8x1.5 Tr9x1.5	MTI06055C13 1.5 TR	6	.217	3	.53	2.3
2	Tr10x2 Tr11x2	MTI08066C21 2 TR	8	.260	3	.83	2.5
2	Tr12x2 Tr14x2	MTI10086D25 2 TR	10	.339	4	.98	2.9
3	Tr12x3	MTI0807C25 3 TR	8	.276	3	.98	2.5
3	Tr14x3 Tr22x3	MTI10089D29 3 TR	10	.350	4	1.14	2.9
4	Tr16x4 Tr18x4 Tr20x4	MTI10092C33 4 TR	10	.362	3	1.30	2.9
5	Tr22x5 Tr24x5 Tr26x5	MTI14135D45 5 TR	14	.531	4	1.77	4.1

Order example: MTI 08066C21 2TR MT8

Acme

Tools for Internal Thread

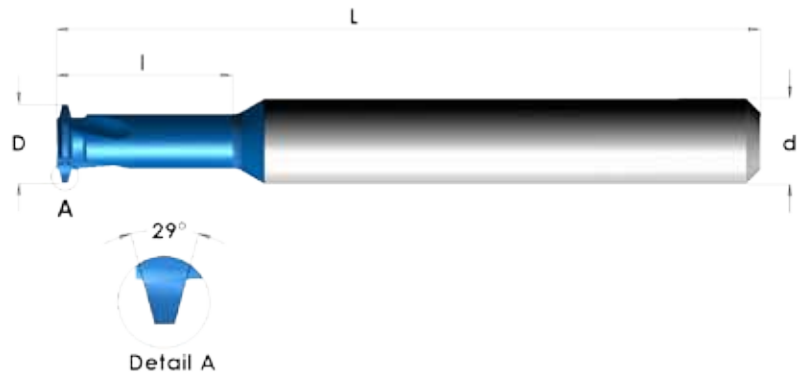

Pitch TPI	Thread size	Ordering Code	d	D	No. of Flutes	l	L
16	1/4-16	MTI0250C04 16 ACME	1/4	.170	3	.38	2.5
14	5/16-14	MTI0250C06 14 ACME	1/4	.205	3	.60	2.5
12	3/8-12 7/16-12	MTI0250C08 12 ACME	1/4	.240	3	.75	2.5
10	1/2-10	MTI0375D10 10 ACME	3/8	.327	4	1.00	3.0
8	5/8-8	MTI0500D11 8 ACME	1/2	.410	4	1.10	3.5
6	3/4-6 7/8-6	MTI0500D12 6 ACME	1/2	.472	4	1.20	3.5
5	1-5 1 1/8-5 1 1/4-5	MTI 0625E15 5 ACME	5/8	.625	5	1.50	4.0

Order example: MTI 0375D10 10ACME MT8

DMT 3 in 1 - *Drill, Thread, Chamfer

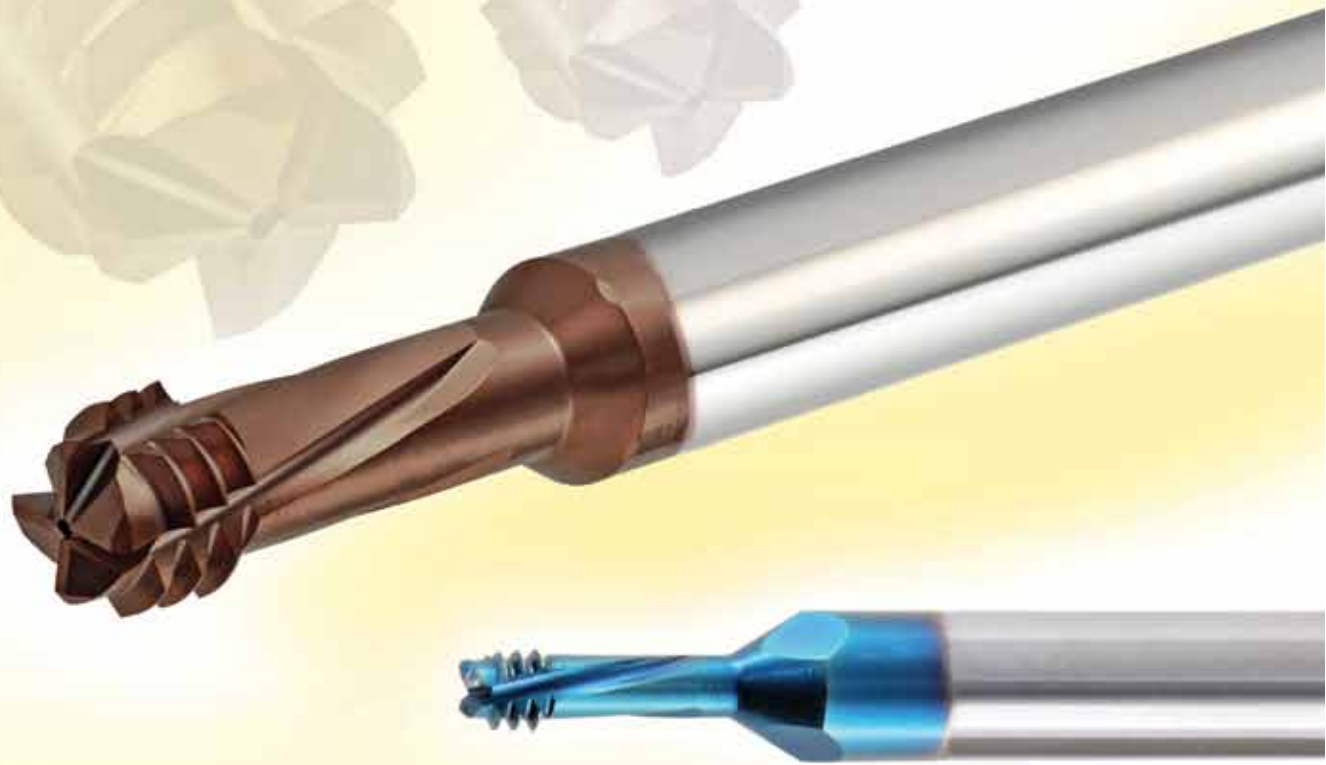

**High Performance tools with internal coolant supply for the production of internal threads.
*Circular movement produces the thread hole, the thread and a chamfer
in one work process.**

Carbide grade: MT7 Sub-micron grade with Titanium Aluminium Nitride multi-layer coating (ISO K10-K20).
MT11 Ultra - fine Sub-micron grade with advanced PVD triple Blue coating (for DMTH)

Advantages of DMT

- Cancels the need for drilling the hole.
- Short cycle time and high performance reduces machining costs.
- Suitable for both blind and through holes.
- Full Profile thread.
- No time lost for tool change, since drilling, chamfering and thread milling are done with one tool.
- Same tool for right-hand or left-hand threads.
- Cuts a wide range of materials.

Contents:	Page:	Contents:	Page:
Product Identification	278	DMTH	
ISO	279	ISO	281
UN	280	UN	282

Product Identification

DMT 3 in 1 - *DRILL, THREAD, CHAMFER Ordering Codes

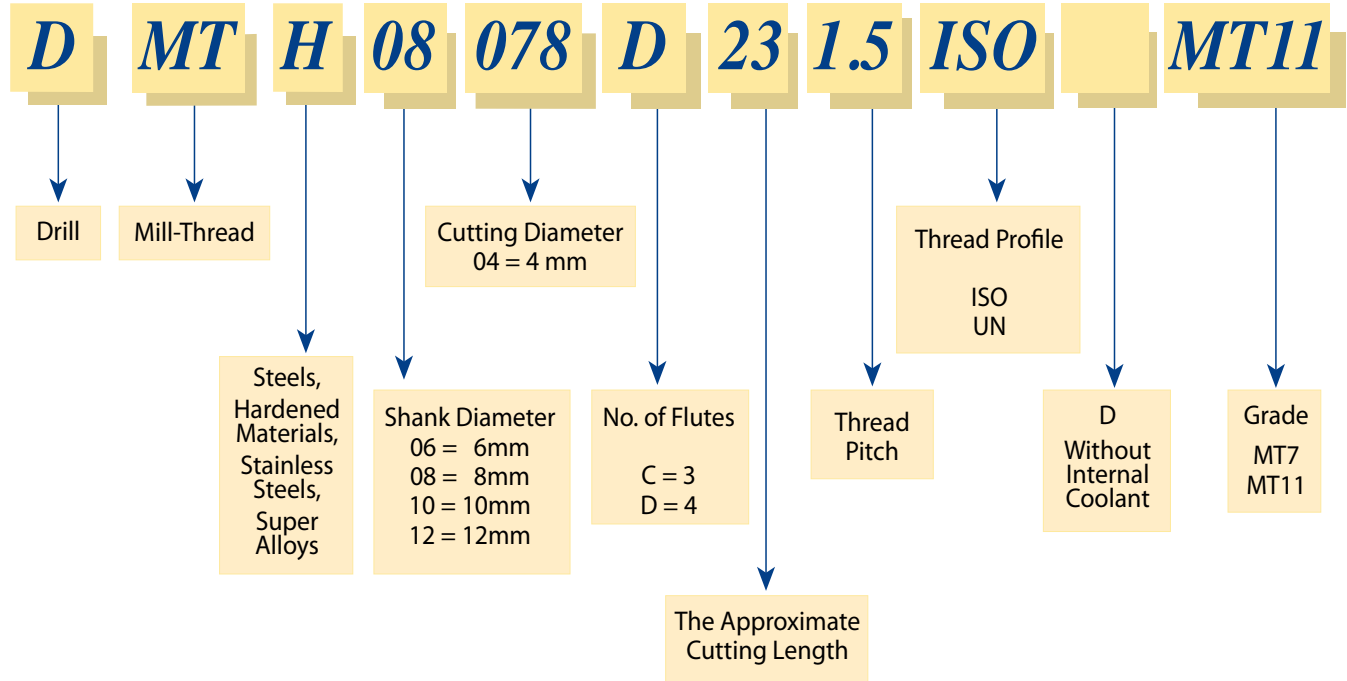

ISO internal coolant bore

Tools for Internal Thread - Metric Shanks

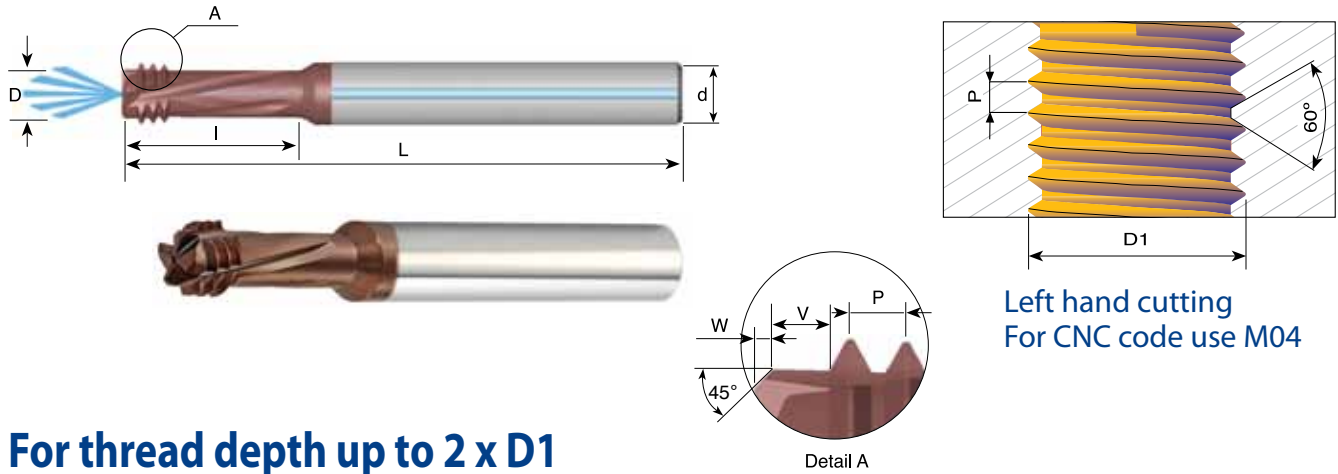

For thread depth up to 2 x D1

Pitch mm	D1	Ordering Code	d mm	D	No. of Flutes	I	W	V	L
1.0	M6 - M9	DMT 08047C14 1.0 ISO	8	.185	3	.55	.016	.039	2.5
1.25	M8 - M12	DMT 08061D18 1.25 ISO	8	.240	4	.71	.020	.049	2.5
1.5	M10 - M15	DMT 08078D23 1.5 ISO	8	.307	4	.91	.024	.059	2.5
1.75	M12	DMT 1009D26 1.75 ISO	10	.354	4	1.02	.024	.069	2.9
2.0	M16 - M23	DMT 12118D35 2.0 ISO	12	.465	4	1.38	.024	.079	3.3

Order example: DMT 08047C14 1.0 ISO MT7

Carbide grade MT7 Sub-Micron grade with Titanium Aluminum Nitride multi-layer coating (ISO K10 - K20). To be run at medium to high cutting speeds. General purpose for all materials.

ISO without internal coolant Metric Shanks

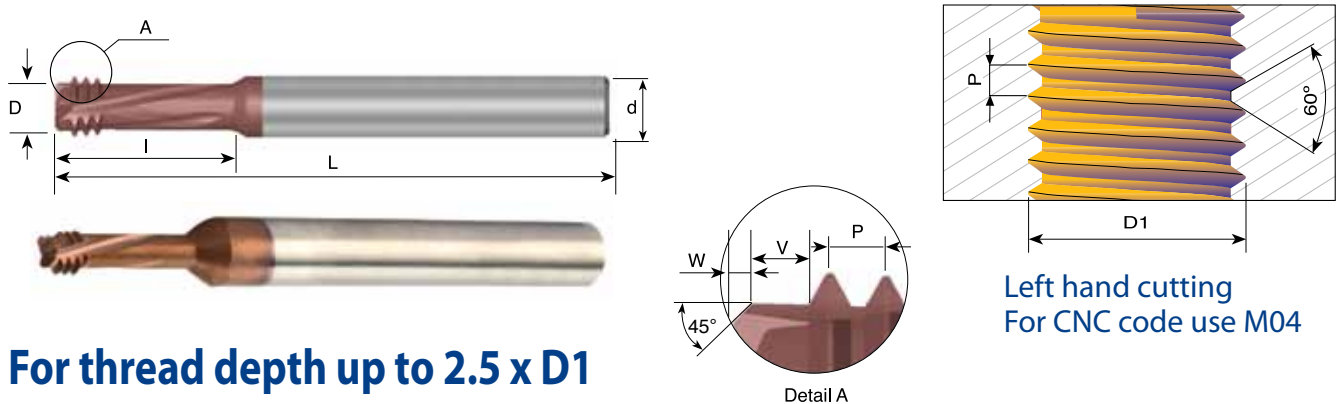

For thread depth up to 2.5 x D1

Pitch mm	D1	Ordering Code	d mm	D	No. of Flutes	I	W	V	L
0.7	M4	DMT 06032C11 0.7 ISO-D	6	.124	3	.46	.008	.028	2.3
0.8	M5	DMT 0604C14 0.8 ISO-D	6	.157	3	.57	.012	.031	2.3

Order example: DMT 06032C11 0.7 ISO-D MT7

Carbide grade MT7 Sub-Micron grade with Titanium Aluminum Nitride multi-layer coating (ISO K10 - K20). To be run at medium to high cutting speeds. General purpose for all materials.

UN internal coolant bore Tools for Internal Thread - Metric Shanks

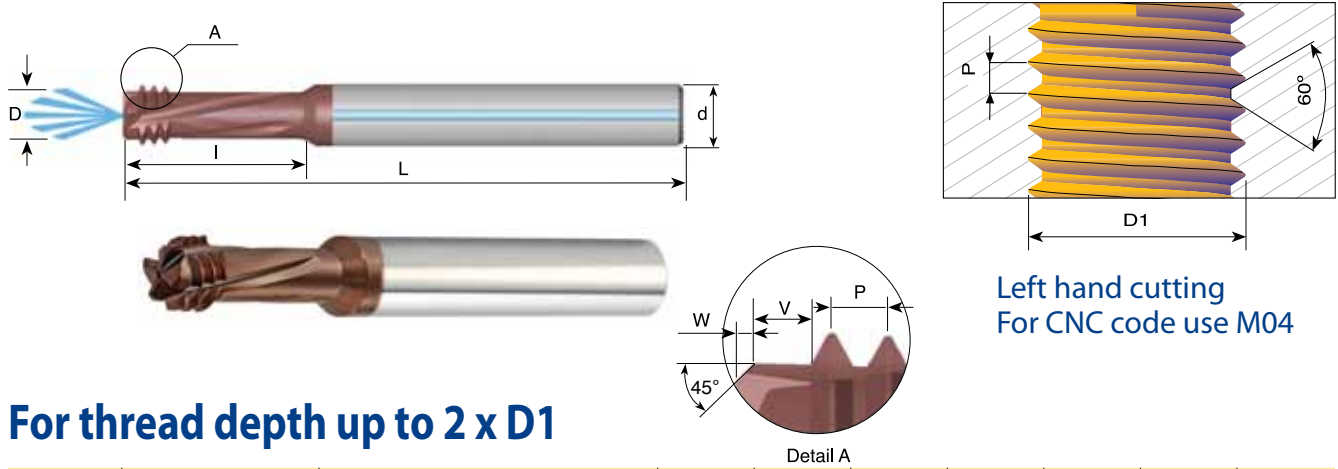

Left hand cutting
For CNC code use M04

For thread depth up to 2 x D1

Pitch TPI	UN, UNEF, UNF UNC, UNS	Ordering Code	d mm	D	No. of Flutes	I	W	V	L
28	1/4 - 3/8	DMT 0805C14 28 UN	8	.197	3	.57	.016	.035	2.5
24	5/16 - 1/2	DMT 08065D17 24 UN	8	.256	4	.67	.020	.041	2.5
20	1/4 - 3/8	DMT 08048C14 20 UN	8	.189	3	.55	.016	.049	2.5
18	5/16 - 7/16	DMT 0806D17 18 UN	8	.236	4	.67	.020	.055	2.5
16	3/8 - 1/2	DMT 08067C22 16 UN	8	.264	3	.87	.020	.063	2.5

Order example: DMT 08067C 22 16 UN MT7

UN without internal coolant Metric Shanks

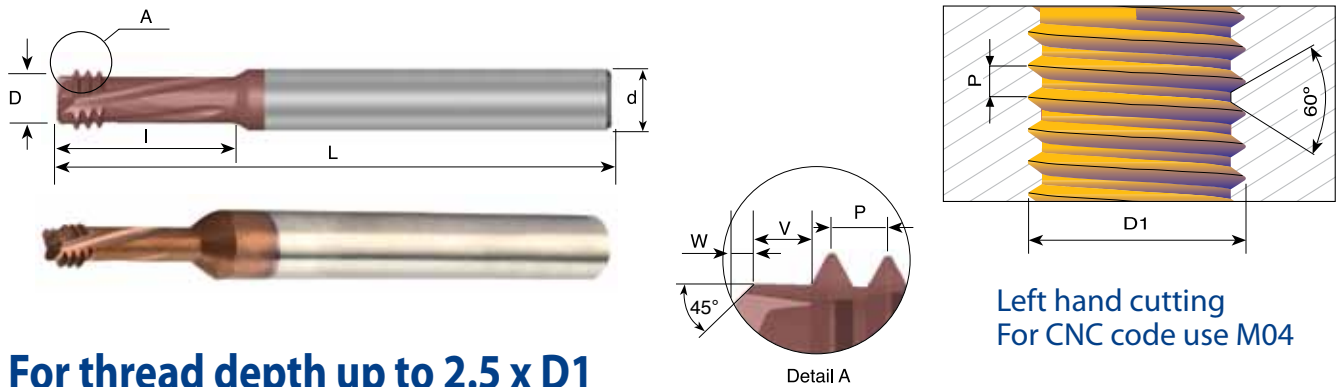

Left hand cutting
For CNC code use M04

For thread depth up to 2.5 x D1

Pitch TPI	UNC	UNF	Ordering Code	d mm	D	No. of Flutes	I	W	V	L
36		8	DMT 06033C12 36 UN-D	6	.130	3	.47	.008	.028	2.3
32	8		DMT 06032C12 32 UN-D	6	.126	3	.48	.012	.031	2.3
32		10	DMT 06038C14 32 UN-D	6	.150	3	.55	.012	.031	2.3

Order example: DMT 06032C12 32UN-D MT7

DMTH

The new DMTH tools expand the range of the existing DMT line providing the ability to cut steels, hardened materials, stainless steels and super alloys.

ISO

Tools for Internal Thread - Metric Shanks

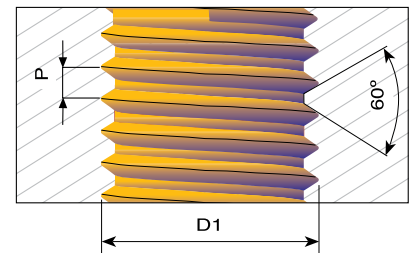
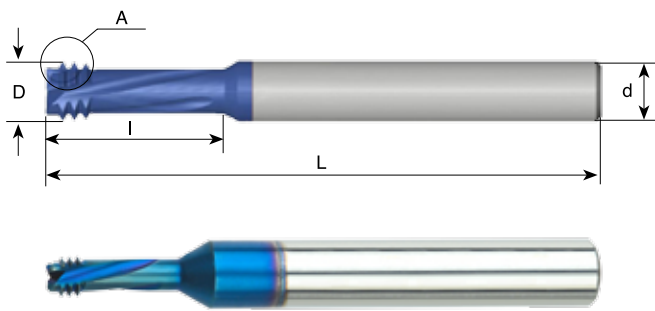

Left hand cutting
For CNC code use M04

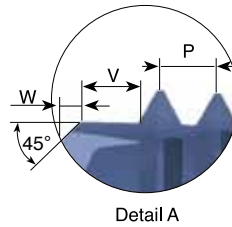

For thread depth up to 2 x D1

Pitch mm	D1	Ordering Code	d mm	D	No. of Flutes	I	W	V	L
0.7	M4	DMTH 06032 C11 0.7 ISO	6	.124	3	.46	.008	.028	2.3
0.8	M5	DMTH 0604 C14 0.8 ISO	6	.157	3	.57	.012	.031	2.3
1.0	M6 - M9	DMTH 08047 C14 1.0 ISO	8	.185	3	.57	.016	.039	2.5
1.25	M8 - M12	DMTH 08061 D19 1.25 ISO	8	.240	4	.75	.020	.049	2.5
1.5	M10- M15	DMTH 08078 D23 1.5 ISO	8	.307	4	.93	.024	.059	2.5
1.75	M12	DMTH 1009 D28 1.75 ISO	10	.354	4	1.11	.024	.069	2.9
2.0	M16- M23	DMTH 12118 D36 2.0 ISO	12	.465	4	1.44	.024	.079	3.3

Order example: DMTH 1009D28 1.75 ISO MT11

UN

Tools for Internal Thread - Metric Shanks

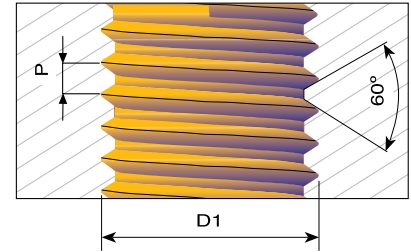
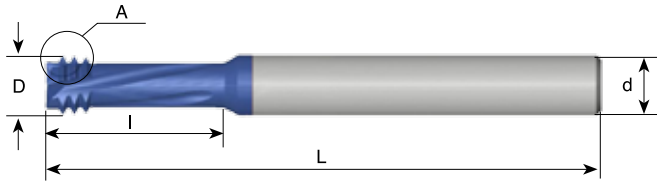

Left hand cutting
For CNC code use M04

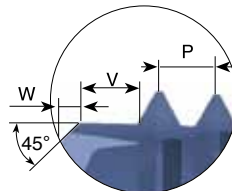

Detail A

For thread depth up to 2 x D1

Pitch TPI	UN, UNEF, UNF UNC, UNS	Ordering Code	d mm	D	No. of Flutes	I	W	V	L
40	4	DMTH06021 C7 40 UN	6	.083	3	.28	.004	.024	2.3
32	6	DMTH06026 C8 32 UN	6	.102	3	.34	.004	.031	2.3
28	1/4-3/8	DMTH0805 C14 28 UN	8	.197	3	.59	.016	.035	2.5
24	5/16-1/2	DMTH08065 D18 24 UN	8	.256	4	.73	.020	.041	2.5
20	1/4-3/8	DMTH08048 C15 20 UN	8	.189	3	.61	.016	.049	2.5
18	5/16-7/16	DMTH0806 D19 18 UN	8	.236	4	.76	.020	.055	2.5
16	3/8-1/2	DMTH08067 C22 16 UN	8	.264	3	.90	.020	.063	2.5
13	1/2	DMTH10092 C30 13 UN	10	.362	3	1.18	.024	.079	2.9
11	5/8	DMTH12114 C37 11 UN	12	.449	3	1.46	.024	.091	3.3

Order example: DMTH 08048 C15 20UN MT11



MTSH Type

Carmex is pioneer in offering solid carbide thread mills tools designed specifically for the machining of hardened materials up to 62HRc. These tools provide high performance, improved cut and an excellent surface finish.

HARDCUT MTSH & MTH Types

Carbide grade: MT9 / MT11 - Ultra fine sub-micron grade with Advanced PVD Triple Coating

MTH Type

Carmex provide new innovative mill thread solid carbide tools for machining:

- Hardened steels and cast iron up to 62 HRc.
- High temperature alloys.
- Titanium alloys.
- Super Alloys (Hastelloy, Inconel, Nickel Base Alloys).

- Threading from ISO M1.4 x 0.3 and 0-80UN
- Perfect solution for the Die and Mold industry
- Working at high cutting speeds
- Short machining time
- Low cutting forces thanks to the short profile

Advantages

- Same tool performs thread milling and chamfering - saves machining time.
- Increased cutting diameter - better rigidity and stability.
- Coating provides high wear and heat resistance.
- Ultra fine grade - dedicated for hardened materials.
- Short chips are produced, insure high process security.
- Short cycle time - increases productivity.
- Thread length up to 2xD.

Contents:	Page:	Contents:	Page:
Product Identification	284	MTH Type	
MTSH Type		ISO	288
ISO	285	UN	288
UN	286		
G55° - BSP	287		

Product Identification

Mini Mill-Thread MTSH Type Ordering Codes

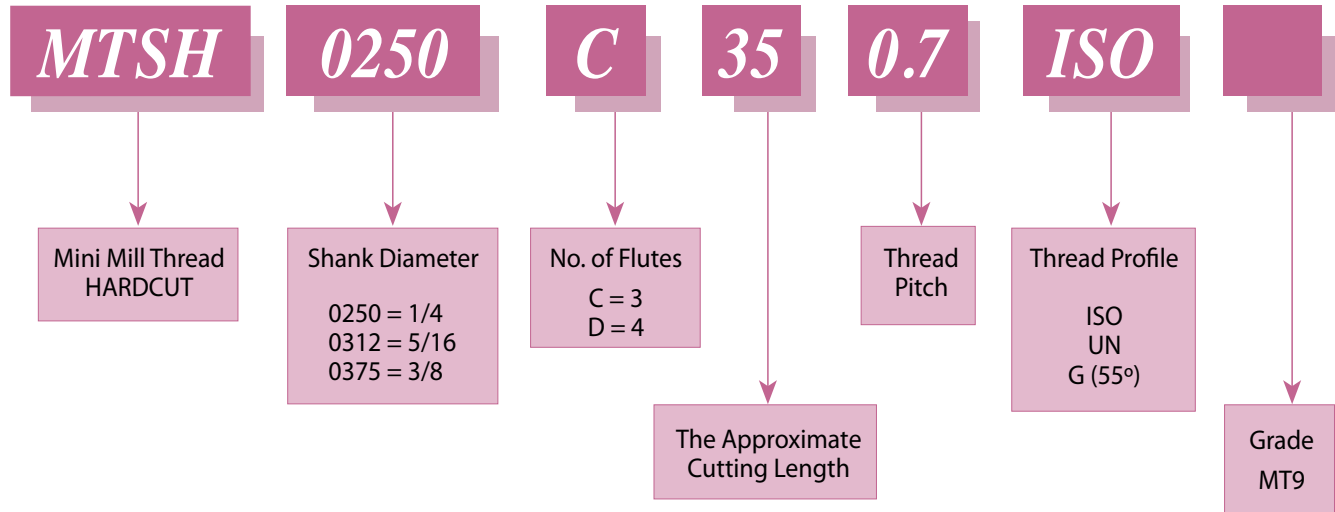

MTH Type Ordering Codes

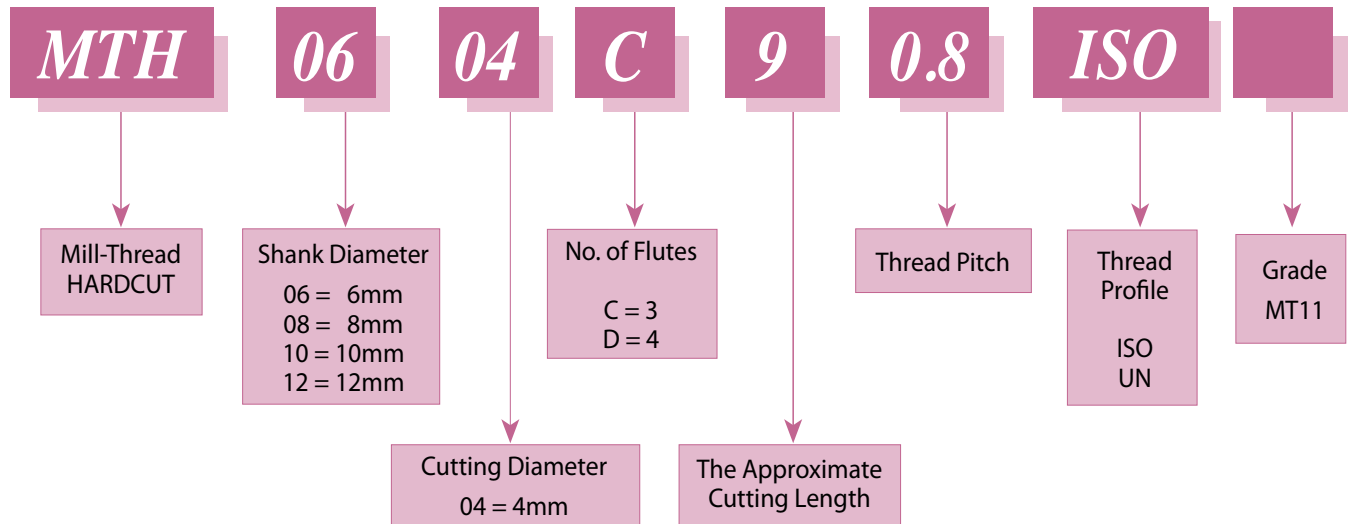

ISO

Tools for Internal Thread

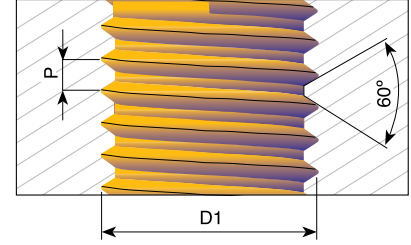
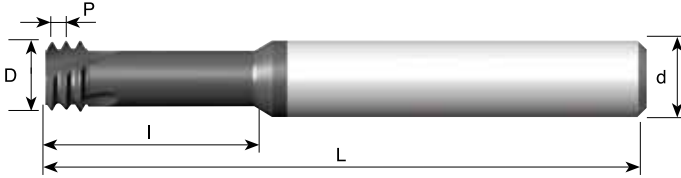

Left hand cutting
For CNC code use M04

Pitch mm	M coarse	M fine	Ordering Code	d	D	No. of Flutes	I	L	Thread depth
0.3	M1.4		MTSH03011C4 0.3 ISO	3 mm	.041	3	.16	1.5	3xD
0.35	M1.6	M2	MTSH03012C5 0.35 ISO	3 mm	.047	3	.19	1.5	3xD
0.4	M2		MTSH0250C18 0.4 ISO	1/4	.060	3	.18	2.5	2xD
0.4	M2		MTSH03016C6 0.4 ISO	3 mm	.060	3	.24	1.5	3xD
0.45	M2.2		MTSH0250C20 0.45 ISO	1/4	.065	3	.20	2.5	2xD
0.45	M2.2		MTSH06017C7 0.45 ISO	6 mm	.065	3	.28	2.3	3xD
0.45	M2.5		MTSH0250C22 0.45 ISO	1/4	.077	3	.22	2.5	2xD
0.45	M2.5		MTSH0250C30 0.45 ISO	1/4	.077	3	.30	2.5	3xD
0.5	M3	M4, M5	MTSH0250C26 0.5 ISO	1/4	.093	3	.26	2.5	2xD
0.5	M3	M4, M5	MTSH0250C37 0.5 ISO	1/4	.093	3	.37	2.5	3xD
0.6	M3.5		MTSH0250C30 0.6 ISO	1/4	.108	3	.30	2.5	2xD
0.6	M3.5		MTSH06028C10 0.6 ISO	6 mm	.108	3	.41	2.3	3xD
0.7	M4		MTSH0250C35 0.7 ISO	1/4	.122	3	.35	2.5	2xD
0.7	M4		MTSH0250C49 0.7 ISO	1/4	.122	3	.49	2.5	3xD
0.8	M5		MTSH0250C49 0.8 ISO	1/4	.150	3	.49	2.5	2xD
0.8	M5		MTSH0250C63 0.8 ISO	1/4	.150	3	.63	2.5	3xD
1.0	M6	M8	MTSH0250C55 1.0 ISO	1/4	.183	3	.55	2.5	2xD
1.0	M6	M8	MTSH0250C79 1.0 ISO	1/4	.183	3	.79	2.5	3xD
1.25	M8	M10, M12	MTSH0250C71 1.25 ISO	1/4	.236	3	.71	2.5	2xD
1.25	M8	M10, M12	MTSH0250C94 1.25 ISO	1/4	.236	3	.94	2.5	3xD
1.5	M10	M14, M16	MTSH0312C91 1.5 ISO	5/16	.307	3	.91	2.5	2xD
1.75	M12		MTSH0375C10 1.75 ISO	3/8	.354	3	1.02	3.0	2xD
2.0	M16	M18, M20	MTSH12118D35 2.0 ISO	12 mm	.465	4	1.38	3.3	2xD

Order example: MTSH 0250C35 0.7 ISO MT9

UN

Tools for Internal Thread

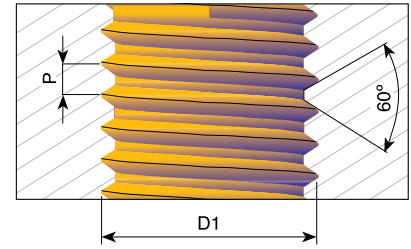
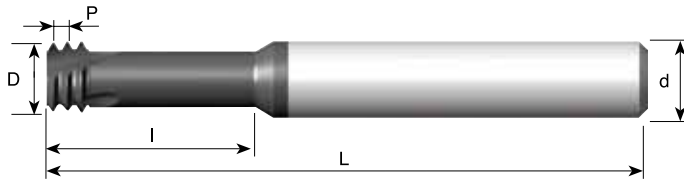

Left hand cutting
For CNC code use M04

Pitch TPI	UNC	UNF	Ordering Code	d	D	No. of Flutes	I	L	Thread depth
80		0	MTSH06012C4 80 UN	6 mm	.045	3	.16	2.3	3xD1
72		1	MTSH0250C15 72 UN	1/4	.057	3	.15	2.5	2xD1
72		1	MTSH03015C6 72 UN	3 mm	.057	3	.24	1.5	3xD1
64	1	2	MTSH0250C15 64 UN	1/4	.055	3	.15	2.5	2xD1
56	2	3	MTSH0250C17 56 UN	1/4	.065	3	.17	2.5	2xD1
56	2	3	MTSH06016C6 56 UN	6 mm	.065	3	.26	2.3	3xD1
48	3	4	MTSH0250C20 48 UN	1/4	.075	3	.20	2.5	2xD1
40	4		MTSH0250C25 40 UN	1/4	.083	3	.25	2.5	2xD1
40	4		MTSH06021C8 40 UN	6 mm	.083	3	.31	2.3	3xD1
40	5	6	MTSH0250C28 40 UN	1/4	.096	3	.28	2.5	2xD1
40	5	6	MTSH0250C38 40 UN	1/4	.096	3	.38	2.5	3xD1
36		8	MTSH0250C35 36 UN	1/4	.130	3	.35	2.5	2xD1
32	6		MTSH0250C28 32 UN	1/4	.100	3	.28	2.5	2xD1
32	6		MTSH06025C10 32 UN	6 mm	.100	3	.41	2.5	3xD1
32	8		MTSH0250C37 32 UN	1/4	.126	3	.37	2.5	2xD1
32	8		MTSH0250C49 32 UN	1/4	.126	3	.49	2.5	3xD1
32		10	MTSH0250C41 32 UN	1/4	.146	3	.41	2.5	2xD1
32		10	MTSH0250C59 32 UN	1/4	.146	3	.59	2.5	3xD1
28		12	MTSH0250C43 28 UN	1/4	.165	3	.43	2.3	2xD1
28		1/4	MTSH0250C57 28 UN	1/4	.197	3	.57	2.5	2xD1
28		1/4	MTSH0250C75 28 UN	1/4	.197	3	.75	2.5	3xD1
24	10, 12		MTSH0250C42 24 UN	1/4	.138	3	.42	2.5	2xD1
24		5/16, 3/8	MTSH0312C67 24 UN	5/16	.260	3	.67	2.5	2xD1
24		5/16, 3/8	MTSH0312C94 24 UN	5/16	.260	3	.94	2.5	3xD1
20	1/4		MTSH0250C55 20 UN	1/4	.187	3	.55	2.5	2xD1
20	1/4		MTSH0250C75 20 UN	1/4	.187	3	.75	2.5	3xD1
20		7/16	MTSH0808C25 20 UN	8 mm	.315	3	.98	2.5	2xD1
18	5/16		MTSH0250C67 18 UN	1/4	.236	3	.67	2.5	2xD1
18	5/16		MTSH0250C91 18 UN	1/4	.236	3	.91	2.5	3xD1
18		5/8	MTSH1212D35 18 UN	12 mm	.472	4	1.38	3.3	2xD1
16	3/8		MTSH0312C87 16 UN	5/16	.264	3	.87	2.5	2xD1
14	7/16		MTSH0312C98 14 UN	5/16	.303	3	.98	2.5	2xD1
13	1/2		MTSH0375C10 13 UN	3/8	.362	3	1.08	3.0	2xD1
12	9/16		MTSH12105C31 12 UN	12 mm	.413	3	1.24	3.3	2xD1
11	5/8		MTSH12114C34 11 UN	12 mm	.449	3	1.36	3.3	2xD1
10	3/4		MTSH16144D41 10 UN	16 mm	.567	4	1.63	4.1	2xD1

Order example: MTSH 0250C28 40 UN MT9

G (55°) BSP

Same Tool for Internal and External Thread

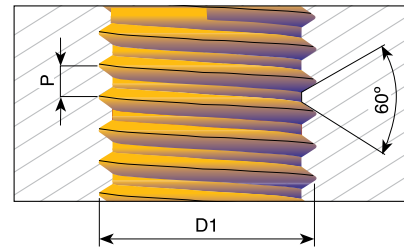
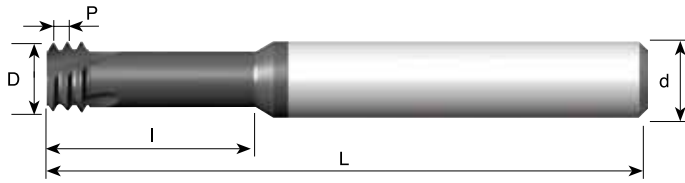

Left hand cutting
For CNC code use M04

Pitch TPI	Standard	Ordering Code	d	D	No. of Flutes	I	L	Thread depth
28	G1/8	MTSH08078 C19 28W	8	.307	3	.77	2.5	2xD1
19	G1/4-3/8	MTSH1010 D30 19W	10	.394	4	1.18	2.9	2xD1
14	G1/2-7/8	MTSH1212 D37 14W	12	.472	4	1.46	3.3	2xD1
11	G≥1	MTSH1616 D44 11W	16	.630	4	1.73	4.1	2xD1

Order example: MTSH 1010D30 19 W MT9

ISO

Tools for Internal Thread Metric Shanks

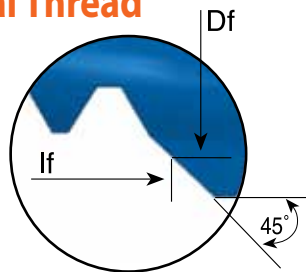

Detail A

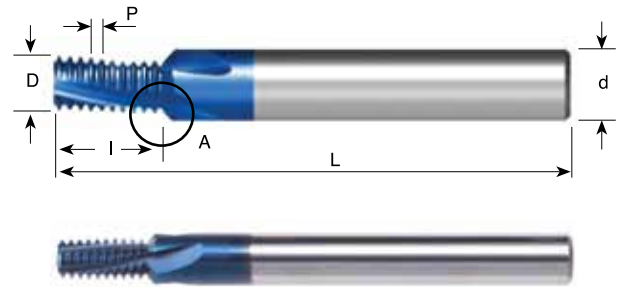

Pitch mm	M coarse	M fine	Ordering Code	d mm	D	Df	No. of Flutes	I	lf	L
0.5	M3	$\varnothing \geq 4$	MTH06024C5 0.5 ISO	6	.094	.142	3	.209	.232	2.3
0.7	M4	$\varnothing \geq 5$	MTH06031C7 0.7 ISO	6	.122	.169	3	.291	.315	2.3
0.8	M5	$\varnothing \geq 6$	MTH0604C9 0.8 ISO	6	.157	.205	3	.362	.386	2.3
1.0	M6	$\varnothing \geq 7$	MTH08048D10 1.0 ISO	8	.189	.252	4	.413	.445	2.5
1.0		$\varnothing \geq 9$	MTH0806D13 1.0 ISO	8	.236	.299	4	.531	.563	2.5
1.0		$\varnothing \geq 10$	MTH1008D16 1.0 ISO	10	.315	.378	4	.650	.681	2.9
1.25	M8	$\varnothing \geq 10$	MTH0806D14 1.25 ISO	8	.236	.299	4	.567	.598	2.5
1.5	M10	$\varnothing \geq 12$	MTH1008D17 1.5 ISO	10	.315	.386	4	.681	.717	2.9
1.5		$\varnothing \geq 14$	MTH1210D21 1.5 ISO	12	.394	.465	4	.858	.894	3.3
1.75	M12	$\varnothing \geq 12$	MTH12095D20 1.75 ISO	12	.374	.453	4	.791	.831	3.3

Order example: MTH08048D10 1.0 ISO MT11

UN

Tools for Internal Thread Metric Shanks

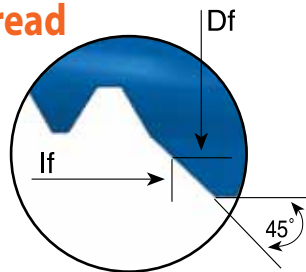

Detail A

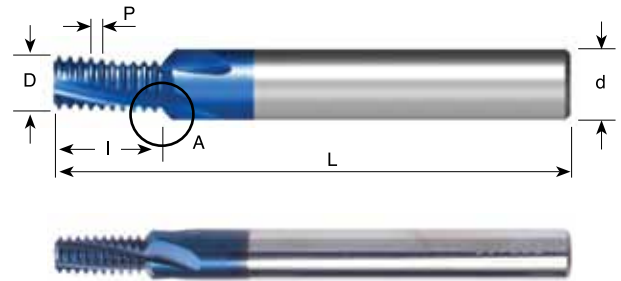

Pitch TPI	UNC	UNF	UNEF	Ordering Code	d mm	D	Df	No. of Flutes	I	lf	L
40	5	6		MTH06025C6 40 UN	6	.098	.146	3	.236	.260	2.3
32	6			MTH06026C5 32 UN	6	.102	.150	3	.232	.256	2.3
32	8			MTH06032C7 32 UN	6	.126	.173	3	.295	.319	2.3
32		10	12	MTH06038C9 32 UN	6	.150	.197	3	.358	.382	2.3
28		1/4		MTH08052D11 28 UN	8	.205	.268	4	.445	.476	2.5
28			7/16, 1/2	MTH12096D20 28 UN	12	.378	.441	4	.803	.835	3.3
24		5/16, 3/8	9/16, 5/8, 11/16	MTH08066D14 24 UN	8	.260	.315	4	.563	.591	2.5
20	1/4			MTH06048C12 20 UN	6	.189	.236	3	.476	.500	2.3
20		7/16, 1/2	3/4, 1	MTH12092D21 20 UN	12	.362	.425	4	.827	.858	3.3
18	5/16	9/16, 5/8	11/16	MTH08057C14 18 UN	8	.224	.295	3	.583	.618	2.5
16	3/8	3/4		MTH10074C16 16 UN	10	.291	.362	3	.657	.693	2.9
14	7/16	7/8		MTH10085D20 14 UN	10	.335	.390	4	.823	.850	2.9
13	1/2			MTH12094D22 13 UN	12	.370	.449	4	.886	.925	3.3

Order example: MTH06048C12 20 UN MT11

Mill-Thread Technical Section



Contents:

Page:

Contents:

Page:

Conversion of Cutting Speed to Rotational Speed	290	Mill-Thread Solid Carbide Grades, Speed and Feed Selection	
Tool Selection	291	MT, MTB, MTZ, EMT types	299
Carmex Mill-Thread Catalog and CNC Programming Software	292	Cutting Data MTQ type	300
Example of Thread Milling CNC Program for Internal Threading	292	FMT Type	301-302
Mill-Thread Inserts Carbide Grades, Speed and Feed Selection	293	AMT Type	303
Spiral Mill-Thread Inserts, Speed and Feed Selection	293	Mini Mill-Thread - MTS and MTI types	304
Spiral Finish Speed Selection	294	MTSB type	305
Cutting Data D-Thread type	295	DMT type	306
Cutting data CMT type	296-298	DMTH type	306
		Mini Mill-Thread - MTSH type	307
		MTH type	308

Conversion of Cutting Speed to Rotational Speed

Conversion of selected cutting speed to rotational speed is calculated by the following formula:

$$N = \frac{V \times 12}{\pi \times D} = \frac{400 \times 12}{3.14 \times 1.25} = 1222 \text{ RPM}$$

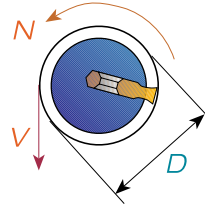

Example: $V=400 \text{ ft/min}$
 $D=1.25$

D=Cutting diameter

Internal Thread

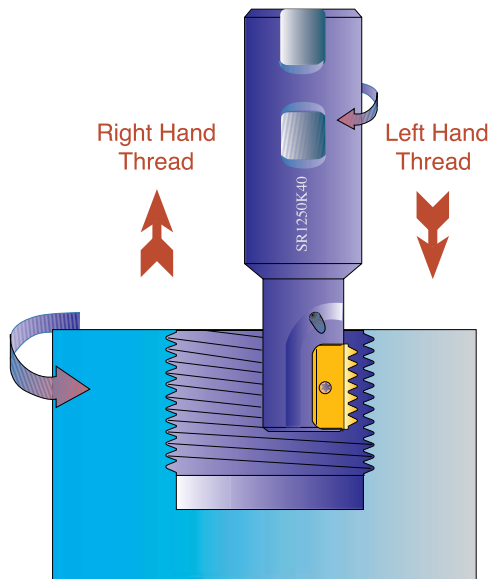

External Thread

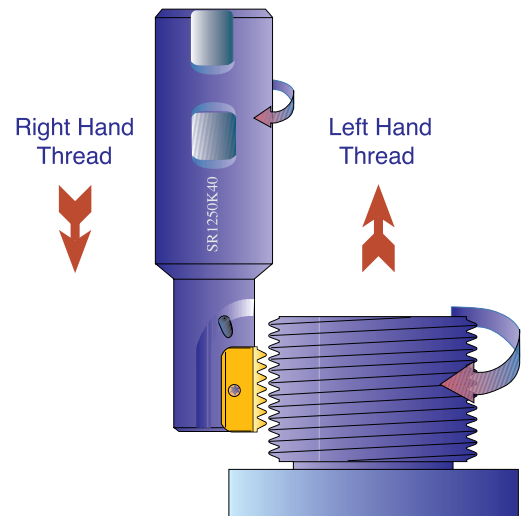

Tool Selection

For indexable and solid carbide Mill Threads

The following chart provides a fairly accurate visual selection tool for Internal Threading. The chart is suitable for the following thread forms: ISO, UN, WHIT, NPT, NPTF, BSPT and PG.

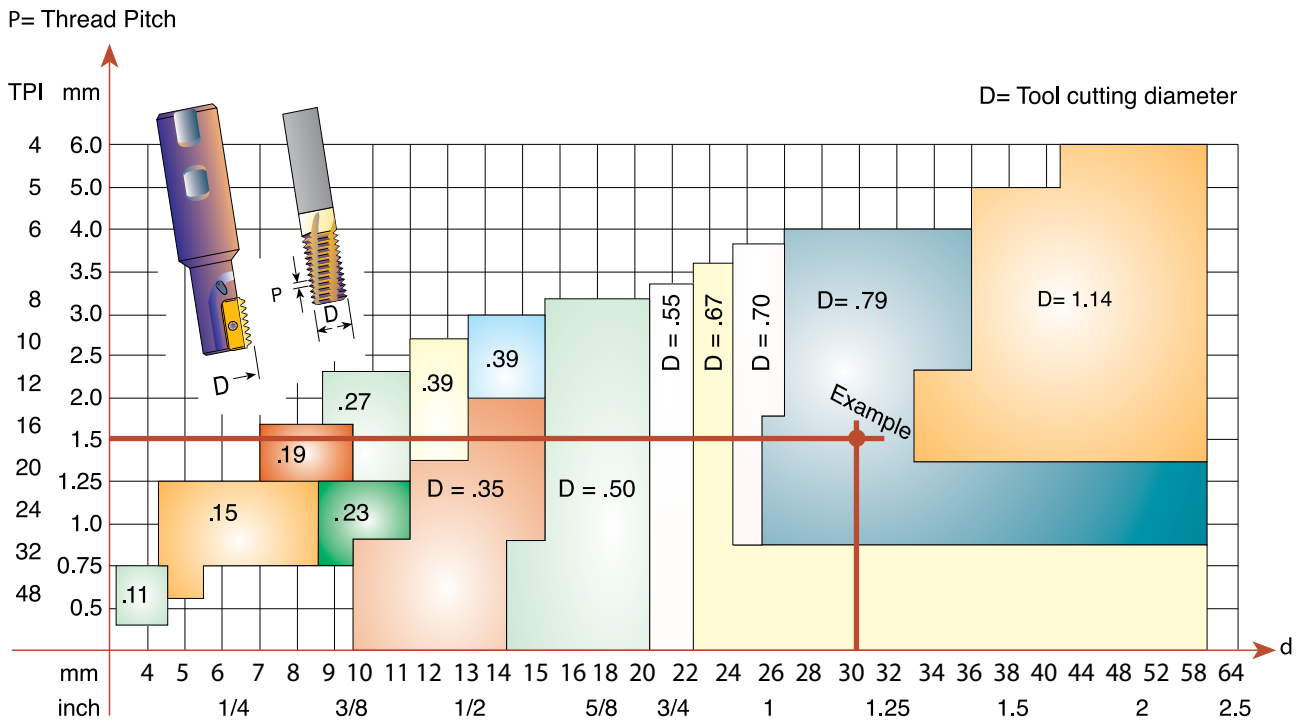

Any tool with a small cutting diameter can produce larger diameter threads.

Example: Internal thread 1 1/4 x 16UN:

Find a Milling Tool to produce d=1.25 Internal

right hand UN thread with a thread pitch P=1/16 inch

As can be seen from the chart above, the two red lines intersect at a selected tool with a cutting diameter of D=.79 inch

Chosen toolholder: SR0790 H21

Insert: 21 I 16 UN MT7

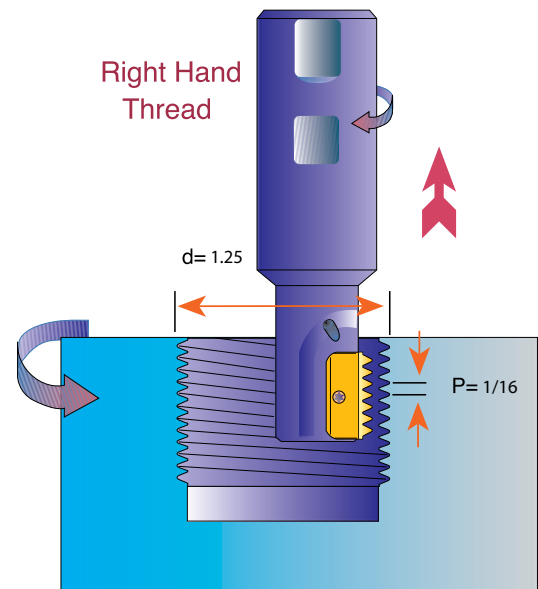

If you need assistance, please call your local distributor and ask for help in selecting the appropriate tool as well as for a CNC program to suit your CNC milling machine.

Carmex Mill-Thread catalog and CNC programming Software

This software is provided by Carmex to assist you, the threadmilling user, to select and apply the correct tool to machine threads on CNC machining centers. The program will find tools and inserts which are suitable for your application, calculate cutting data and generate a CNC program for a variety of controls.



The software is available at our web site.

Example of Thread Milling CNC Program for Internal Threading

Right hand thread (climb milling) from bottom up.

Program is based on tool center.

This method of programming needs no tool radius compensation value other than an offset for wear.

$$A = \frac{D_o - D}{2}$$

A = Radius of tool path
 D_o = Major thread dia.
 D = Cutting dia.

General Program

```
G90 G00 G54 G43 H1X0 Y0 Z10 S---
G00 Z- (TO THREAD DEPTH)
G01 G91 G41 D1 X(A/2) Y-(A/2) Z0 F---
G03 X(A/2) Y(A/2) R(A/2) Z(1/8 PITCH)
G03 X0 Y0 I-(A) J0 Z(PITCH)
G03 X-(A/2) Y(A/2) R(A/2) Z(1/8 PITCH)
G01 G40 X-(A/2) Y-(A/2) Z0
G90 X0 Y0 Z0
```

Internal Thread

EXAMPLE: 1 1/4-12UN (Thread depth .71)
 TOOLHOLDER: SR0790 H21 (Cutting Dia. .79)
 INSERT: 21 I 12 UN
 $A = (1.25 - .79)/2 = .23$

```
G90 G00 G54 G43 H1X0 Y0 Z0.39 S2800
G00 Z-0.71
G01 G91 G41X0.1150Y-0.1150 Z0 F3.35 D1
G03 X0.1150
Y0.1150 R0.1150 Z0.0104
G03 X0 Y0 I-0.23 J0 Z0.0833
G03 X-0.1150Y0.1150 R0.1150 Z0.0104
G01 G40 X-0.1150Y-0.1150 Z0
G90 G0 X0 Y0 Z0
```

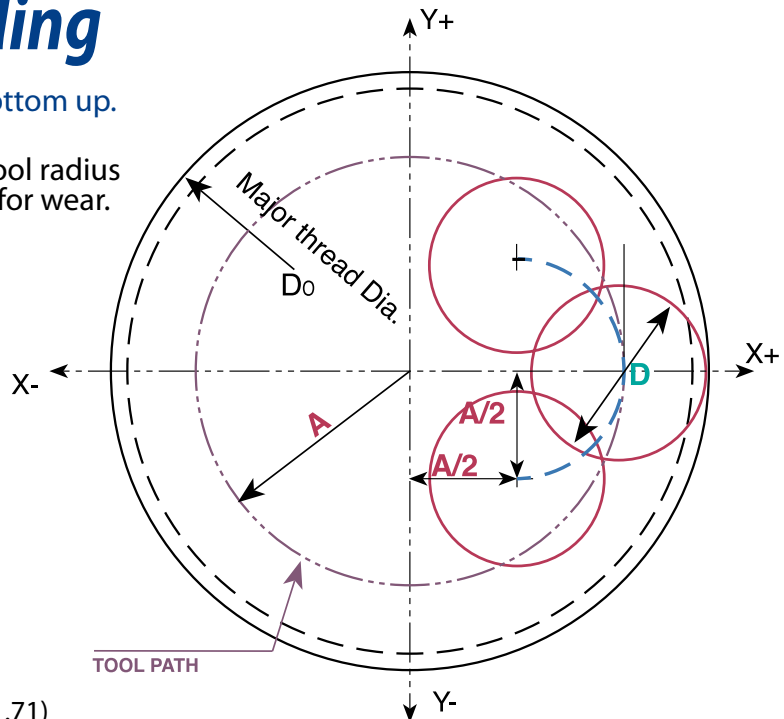

Mill-Thread Inserts Speed and Feed Selection

MT7 Sub-Micron Grade with Titanium Aluminum Nitride multi-layer coating (ISO K10 - K20). This is a general purpose grade, which can be used with all materials; it should be run at medium to high cutting speeds.

ISO	Materials	Cutting Speed ft/min MT7
P	Low and Medium Carbon Steels	380 - 920
	High Carbon Steels	430 - 660
	Alloy Steels, Treated Steels	340 - 590
M	Stainless Steels	430 - 620
	Cast Steels	490 - 620
K	Cast Iron	260 - 560
N	Non-Ferrous & Aluminum	590 - 1120
	Synthetics, Duroplastics, Thermoplastics	380 - 1500
S	Nickel Alloys, Titanium Alloys	80 - 300

Recommended Feed Rate: .002 - .006

Spiral Mill-Thread Inserts Speed and Feed Selection

MT7 Sub-Micron Grade with Titanium Aluminum Nitride multi-layer coating (ISO K10 - K20). This is a general purpose grade, which can be used with all materials; it should be run at medium to high cutting speeds.

ISO	Materials	Cutting Speed ft/min MT7
P	Low and Medium Carbon Steels	480 - 1200
	High Carbon Steels	540 - 840
	Alloy Steels, Treated Steels	440 - 755
M	Stainless Steels	540 - 800
	Cast Steels	620 - 800
K	Cast Iron	330 - 720
N	Non-Ferrous & Aluminum	755 - 1440
	Synthetics, Duroplastics, Thermoplastics	480 - 1940
S	Nickel Alloys, Titanium Alloys	100 - 380

Recommended Feed Rate: .002 - .006

As you may note, cutting speed is shown in range terms. In most standard cases choosing a speed in the middle of the range would be a good choice for a start.

For hard metals reduce cutting speed.

Spiral Finish Speed and Feed Selection

MT7 Sub-Micron Grade with Titanium Aluminum Nitride multi-layer coating (ISO K10 - K20). This is a general purpose grade, which can be used with all materials; it should be run at medium to high cutting speeds.

ISO	Materials	Cutting Speed (ft/min)
P	Low and Medium Carbon Steels	660 - 1080
	High Carbon Steels	560 - 7700
	Alloy Steels, Treated Steels	330 - 640
M	Stainless Steels	590 - 755
	Cast Steels	590 - 755
K	Cast Iron	660 - 1150
N	Non-Ferrous & Aluminum	1640 - 3610
	Synthetics, Duroplastics, Thermoplastics	1310 - 4920
S	Nickel Alloys, Titanium Alloys	100 - 180

Cutting Data

D-Thread type

MT7 Sub-Micron Grade with Titanium Aluminum Nitride multi-layer coating (ISO K10 - K20). This is a general purpose grade, which can be used with all materials; it should be run at medium to high cutting speeds.

ISO	Materials	Cutting Speed (ft/min)
P	Low and Medium Carbon Steels <0.55%C	330 - 670
	High Carbon Steels ≥0.55%C	330 - 590
	Alloy Steels, Treated Steels	330 - 460
M	Stainless Steels - Free Cutting	280 - 410
	Stainless Steels - Austenitic	260 - 380
	Cast Steels	380 - 510
K	Cast Iron	250 - 480
N	Aluminum ≤12%Si, Copper	490 - 980
	Aluminum >12% Si	490 - 980
	Synthetics, Duroplastics, Thermoplastics	330 - 1150
S	Nickel Alloys, Titanium Alloys	150 - 310

Recommended Feed Rate: .003 - .006

Cutting Data

CMT type

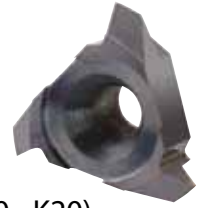

MT7 Sub-Micron Grade with Titanium Aluminum Nitride multi-layer coating (ISO K10 - K20). This is a general purpose grade, which can be used with all materials; it should be run at medium to high cutting speeds.

ISO	Materials	Cutting Speed ft/min	Feed inch/tooth Cutting Diameter=D			
			Ø.39	Ø.47	Ø.70	Ø.98
P	Low and Medium Carbon Steels <0.55%C	197 - 394	.0063	.0067	.0079	.0087
	High Carbon Steels ≥0.55%C	197 - 295	.0055	.0063	.0079	.0087
	Alloy Steels, Treated Steels	164 - 262	.0039	.0047	.0063	.0071
M	Stainless Steels - Free Cutting	230 - 328	.0039	.0043	.0059	.0067
	Stainless Steels - Austenitic	197 - 295	.0039	.0043	.0059	.0067
	Cast Steels	230 - 295	.0039	.0047	.0063	.0071
K	Cast Iron	131 - 262	.0063	.0067	.0079	.0087
N	Aluminum ≤12%Si, Copper	328 - 656	.0063	.0067	.0079	.0087
	Aluminum >12% Si	197 - 459	.0039	.0043	.0061	.0071
	Synthetics, Duroplastics, Thermoplastics	164 - 656	.0075	.0075	.0087	.0094
S	Nickel Alloys, Titanium Alloys	66 - 131	.0028	.0028	.0039	.0047
H	Hardened Steel 45 - 50HRc	197 - 230	.0035	.0035	.0051	.0059
	Hardened Steel 50 - 55HRc	164 - 197	.0031	.0031	.0047	.0055

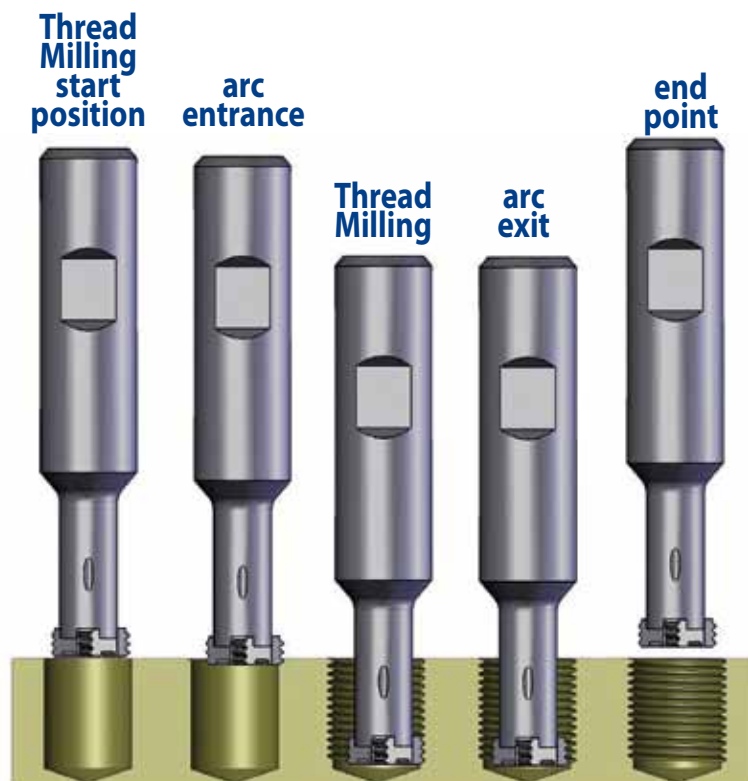

Cutting Data

CMT Spiral Multi Flute Inserts

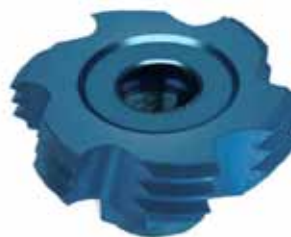

Carbide grade - MT8:

Sub-Micron Grade with Aluminum Titanium Nitride (AlTiN) multi-layer coating (ISO K10-K20). Extremely high heat resistant and smooth cutting operation, for high performance, and normal machining conditions. General purpose for all materials.

ISO Standard	Material	Cutting Speed ft/min	Feed inch/tooth Cutting Diameter = D
			Ø.63-Ø1.38
P	Low and Medium Carbon Steels <0.55%C	197 - 394	.0055 - .0094
	High Carbon Steels ≥0.55%C	197 - 295	.0047 - .0094
	Alloy Steels, Treated Steels	164 - 262	.0031 - .0079
M	Stainless Steel-Free Cutting	230 - 328	.0031 - .0075
	Stainless Steel-Austenitic	197 - 295	.0031 - .0075
	Cast Steels	230 - 295	.0031 - .0079
K	Cast Iron	131 - 262	.0055 - .0094
N	Aluminum ≤12%Si, Copper	328 - 656	.0055 - .0102
	Aluminum >12%Si	197 - 459	.0031 - .0087
	Synthetics, Duroplastics, Thermoplastics	164 - 656	.0067 - .0110
S	Nickel Alloys, Titanium Alloys.	66 - 131	.0020 - .0055
H	Hardened Steel, 45-50HRc	197 - 230	.0028 - .0067
	Hardened Steel, 51-55HRc	164 - 197	.0024 - .0063

Cutting Data

CMT Milling cutter



ISO Standard	Material	Cutting Speed ft/min	Feed inch/tooth
P	Low and Medium Carbon Steels <0.55%C	197 - 394	.0020-.0059
	High Carbon Steels ≥0.55%C	197 - 295	.0020-.0039
	Alloy Steels, Treated Steels	164 - 262	.0020-.0039
M	Stainless Steel-Free Cutting	230 - 328	.0016-.0051
	Stainless Steel-Austenitic	197 - 295	.0016-.0039
	Cast Steels	230 - 295	.0016-.0051
K	Cast Iron	131 - 262	.0020-.0059
N	Aluminum ≤12%Si, Copper	328 - 656	.0020-.0098
	Aluminum >12%Si	197 - 459	.0012-.0039
	Synthetics, Duroplastics, Thermoplastics	164 - 656	.0020-.0098
S	Nickel alloys, Titanium Alloys.	66 - 131	.0012-.0039
H	Hardened Steel, ≤ 45 HRC	197 - 230	.0012-.0039

Mill-Thread Solid Carbide Grades, Speed and Feed Selection

MT Type

MT7 Sub-Micron Grade with Titanium Aluminum Nitride multi-layer coating (ISO K10 - K20). This is a general purpose grade, which can be used with all materials; it should be run at medium to high cutting speeds.

ISO	Materials	Cutting Speed ft/min	Feed inch/tooth Cutting Diameter=D										
			Ø.08	Ø.12	Ø.16	Ø.24	Ø.31	Ø.39	Ø.47	Ø.55	Ø.63	Ø.79	Ø.98
P	Low and Medium Carbon Steels <0.55%C	300- 660	.0012	.0016	.0016	.0024	.0028	.0032	.0037	.0042	.0047	.0057	.0070
	High Carbon Steels ≥0.55%C	330- 480	.0009	.0011	.0013	.0018	.0022	.0026	.0031	.0035	.0039	.0048	.0059
	Alloy Steels, Treated Steels												
M	Stainless Steels - Free Cutting	180- 430	.0008	.0012	.0010	.0016	.0020	.0024	.0024	.0028	.0031	.0035	.0043
	Stainless Steels - Austenitic												
	Cast Steels	390- 440	.0008	.0009	.0010	.0013	.0016	.0018	.0021	.0023	.0026	.0031	.0038
K	Cast Iron	210- 390	.0011	.0014	.0017	.0022	.0027	.0032	.0037	.0042	.0047	.0057	.0070
N	Aluminum ≤12%Si, Copper	440- 920	.0011	.0014	.0017	.0022	.0027	.0032	.0037	.0042	.0047	.0057	.0070
	Aluminum >12% Si	300- 660	.0008	.0009	.0010	.0013	.0016	.0018	.0021	.0023	.0026	.0031	.0038
	Synthetics, Duroplastics, Thermoplastics	300-1050	.0021	.0024	.0027	.0032	.0038	.0043	.0049	.0054	.0060	.0071	.0085
S	Nickel Alloys, Titanium Alloys												

MTB, MTZ, EMT Types

ISO	Materials	Cutting Speed ft/min	Feed inch/tooth Cutting Diameter=D										
			Ø.08	Ø.12	Ø.16	Ø.24	Ø.31	Ø.39	Ø.47	Ø.55	Ø.63	Ø.79	Ø.98
P	Low and Medium Carbon Steels <0.55%C	330- 820	.0012	.0016	.0016	.0024	.0028	.0032	.0037	.0042	.0047	.0057	.0070
	High Carbon Steels ≥0.55%C	360- 590	.0009	.0011	.0013	.0018	.0022	.0026	.0031	.0035	.0039	.0048	.0059
	Alloy Steels, Treated Steels	300- 520	.0008	.0009	.0010	.0013	.0016	.0018	.0021	.0023	.0026	.0031	.0038
M	Stainless Steels - Free Cutting	200- 520	.0008	.0012	.0010	.0016	.0020	.0024	.0024	.0028	.0031	.0035	.0043
	Stainless Steels - Austenitic	200- 390	.0008	.0008	.0012	.0012	.0016	.0020	.0020	.0024	.0028	.0031	.0039
	Cast Steels	430- 560	.0008	.0009	.0010	.0013	.0016	.0018	.0021	.0023	.0026	.0031	.0038
K	Cast Iron	230- 490	.0011	.0014	.0017	.0022	.0027	.0032	.0037	.0042	.0047	.0057	.0070
N	Aluminum ≤12%Si, Copper	490-1150	.0011	.0014	.0017	.0022	.0027	.0032	.0037	.0042	.0047	.0057	.0070
	Aluminum >12% Si	330- 820	.0008	.0009	.0010	.0013	.0016	.0018	.0021	.0023	.0026	.0031	.0038
	Synthetics, Duroplastics, Thermoplastics	330-1310	.0021	.0024	.0027	.0032	.0038	.0043	.0049	.0054	.0060	.0071	.0085
S	Nickel Alloys, Titanium Alloys	70- 260	.0009	.0009	.0010	.0010	.0011	.0012	.0013	.0014	.0015	.0017	.0019

For cutters with long cutting length reduce feed rate by 40%

MTQ type

Thread mills with relieved neck and internal coolant for milling medium and large threads on relatively deep work pieces.

Carbide grade: MT7

- To produce medium and large threads on relatively deep work pieces.
- To use overhang according to the application.
- To perform deep threads at the bottom of the application.

Advantages

- Provides high rigidity and stability (anti-vibration).
- Accomplishes deep threads in one pass.
- Relatively low cutting forces due to short cutting length.
- Threads length up to 3D.

MT7 Sub-Micron Grade with Titanium Aluminum Nitride multi-layer coating (ISO K10 - K20). This is a general purpose grade, which can be used with all materials; it should be run at medium to high cutting speeds.

ISO	Materials	Cutting Speed ft/min	Feed inch/tooth Cutting Diameter=D					
			Ø.39	Ø.47	Ø.55	Ø.63	Ø.79	Ø.98
P	Low and Medium Carbon Steels <0.55%C	330 - 820	.0022	.0026	.0029	.0033	.0040	.0049
	High Carbon Steels ≥0.55%C	360 - 590	.0018	.0021	.0025	.0028	.0034	.0041
	Alloy Steels, Treated Steels	300 - 520	.0013	.0014	.0016	.0018	.0022	.0026
M	Stainless Steels - Free Cutting	200 - 520	.0017	.0017	.0019	.0022	.0025	.0030
	Stainless Steels - Austenitic	200 - 390	.0014	.0014	.0017	.0019	.0022	.0028
	Cast Steels	430 - 560	.0013	.0014	.0016	.0018	.0022	.0026
K	Cast Iron	230 - 490	.0022	.0026	.0029	.0033	.0040	.0049
N	Aluminum ≤12%Si, Copper	490 - 1150	.0022	.0026	.0029	.0033	.0040	.0049
	Aluminum >12% Si	330 - 820	.0013	.0014	.0016	.0018	.0022	.0026
	Synthetics, Duroplastics, Thermoplastics	330 - 1310	.0030	.0034	.0038	.0042	.0050	.0059
S	Nickel Alloys, Titanium Alloys	70 - 260	.0009	.0009	.0010	.0010	.0012	.0013

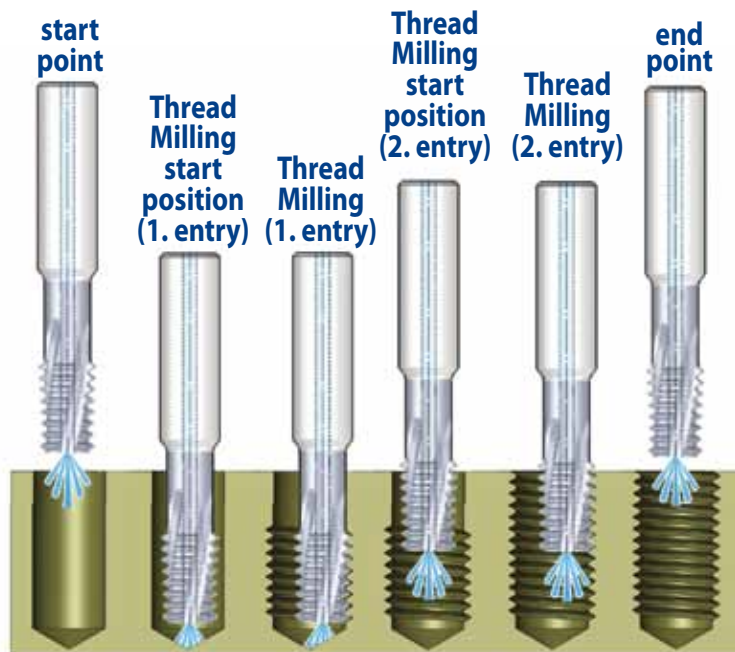

FMT Fast MT

- Carmex has designed a unique line of solid carbide thread milling tools FMT for increased productivity and high performance.
- Large number of flutes enables to achieve significant shorter machining time.

FMT vs. Taps

Features	FMT	Taps
Thread up to bottom at blind hole	Possible	Not possible
Machining load	Very low	High
Thread surface quality	High	Medium
Process reliability	Very reliable, especially for expensive work pieces	Medium
Thread geometry	Very accurate	Medium
Cycle time	Same or faster than tap	Fast

MT8 Sub Micron grade with advanced PVD triple coating (ISO K10-K20). Extremely high heat resistant and smooth cutting operation, for high performance and normal machining conditions. General purpose for all materials.

Test Report

Application

Internal right hand thread: M6x1.0
 Thread length: .39", Blind hole
 Bore size: Ø.197
 Chamfer: .035

Work piece material

Steel SAE 4340

Cutter description

FMT08048F10 1.0 ISO- with internal coolant
 Shank diameter: Ø8 mm
 Cutting diameter: Ø.189"
 Number of flutes: 6
 Cutting length: .41"
 Total length: 2.5

Cutting conditions

Cutting speed: 426 ft/min Feed: 0.00063 inch/tooth

Machine

Mori Seiki NV5000 Coolant: emulsion 5%

Results

Tool life : 2,170 threads
 Cycle time: 1.5 sec

FMT

ISO Standard	Materials	Cutting Speed ft/min	Feed inch/tooth Cutting Diameter = D				
			Ø.17	Ø.24	Ø.31	Ø.39	Ø.47
P	Low and Medium Carbon Steels < 0.55%C	330 - 820	.0012	.0024	.0028	.0031	.0035
	High Carbon Steels ≥ 0.55%C	360 - 590	.0012	.0020	.0024	.0028	.0031
	Alloy Steels, Treated Steels	300 - 520	.0008	.0012	.0016	.0020	.0020
M	Stainless Steel - Free Cutting	200 - 520	.0012	.0016	.0020	.0024	.0024
	Stainless Steel - Austenitic	200 - 390	.0004	.0012	.0016	.0020	.0020
	Cast Steels	430 - 560	.0008	.0012	.0016	.0020	.0020
K	Cast Iron	230 - 490	.0016	.0024	.0028	.0031	.0035
N	Aluminum ≤ 12%Si, Copper	490 - 1150	.0016	.0024	.0028	.0031	.0035
	Aluminum > 12%Si	330 - 820	.0012	.0012	.0016	.0020	.0020
	Synthetics, Duroplastics, Thermoplastics	330 - 1310	.0024	.0031	.0039	.0043	.0047
S	Nickel Alloys, Titanium Alloys.	70 - 260	.0008	.0012	.0012	.0012	.0012
H	Hardened Steel, 45-50HRc	195 - 230	.0008	.0012	.0012	.0012	.0012

AMT

Carbide grade K20:

Uncoated Sub- Micron carbide grade for Aluminum and non- ferrous materials, Stainless Steels and Titanium.

ISO Standard	Materials	Cutting Speed ft/min	Feed inch/tooth Cutting Diameter = D		
			D ≤ .16	.16 < D < .35	D ≥ .35
P	Low & Medium Carbon Steels < 0.55%C	160-460	.0002 - .0012	.0004 - .0020	.0008 - .0039
	High Carbon Steels ≥0.55%C	200-430	.0002 - .0008	.0004 - .0016	.0008 - .0035
	Alloy Steels, Treated Steels				
M	Stainless Steel-Free Cutting	130-390	.0002 - .0008	.0004 - .0016	.0008 - .0035
	Stainless Steel-Austenitic				
	Cast Steels	230-390	.0002 - .0012	.0004 - .0020	.0008 - .0039
K	Cast Iron	160-390	.0002 - .0012	.0004 - .0020	.0008 - .0039
N	Aluminum ≤12%Si, Copper	430-820	.0002 - .0016	.0004 - .0024	.0008 - .0051
	Aluminum >12%Si	260-590	.0002 - .0016	.0004 - .0024	.0008 - .0051
	Synthetics, Duroplastics, Thermoplastics	260-590	.0002 - .0016	.0004 - .0024	.0008 - .0051
S	Nickel Alloys, Titanium Alloys	65-260	.0002 - .0008	.0004 - .0016	.0008 - .0035

Mini Mill-Thread MTS and MTI types

- MT7** Sub-Micron Grade with Titanium Aluminum Nitride multi-layer coating (ISO K10 - K20). This is a general purpose grade, which can be used with all materials; it should be run at medium to high cutting speeds.
- MT8** Sub-Micron Grade with Aluminum Titanium Nitride (AlTiN) multi-layer coating (ISO K10-K20). Extremely high heat resistant and smooth cutting operation, for high performance, and normal machining conditions. General purpose for all materials.
- MT11** Ultra-fine sub-micron grade with advanced PVD triple coating.

ISO Standard	Materials	Cutting Speed ft/min	Feed inch/tooth Cutting Diameter = D													
			Ø.04	Ø.06	Ø.08	Ø.12	Ø.16	Ø.20	Ø.24	Ø.28	Ø.31	Ø.35	Ø.39	Ø.47	Ø.55	Ø.63
P	Low and Medium Carbon Steels <0.55%C	200-390	.0016	.0020	.0020	.0028	.0035	.0043	.0051	.0055	.0059	.0063	.0063	.0067	.0071	.0071
	High Carbon Steels ≥0.55%C	200-300	.0012	.0016	.0020	.0024	.0031	.0035	.0039	.0047	.0051	.0055	.0055	.0063	.0067	.0071
	Alloy Steels, Treated Steels	160-260	.0012	.0016	.0016	.0020	.0020	.0024	.0028	.0028	.0031	.0035	.0039	.0047	.0051	.0055
M	Stainless Steels - Free Cutting	230-330	.0008	.0012	.0012	.0016	.0020	.0024	.0024	.0028	.0031	.0035	.0039	.0043	.0047	.0051
	Stainless Steels - Austenitic	200-300	.0008	.0012	.0012	.0016	.0020	.0024	.0024	.0028	.0031	.0035	.0039	.0043	.0047	.0051
	Cast Steels	230-300	.0012	.0016	.0016	.0020	.0020	.0024	.0028	.0028	.0031	.0035	.0039	.0047	.0051	.0055
K	Cast Iron	130-260	.0016	.0020	.0020	.0028	.0035	.0043	.0051	.0055	.0059	.0063	.0063	.0067	.0071	.0071
N	Aluminum ≤12%Si, Copper	330-660	.0016	.0020	.0020	.0028	.0035	.0043	.0051	.0055	.0059	.0063	.0063	.0067	.0071	.0071
	Aluminum >12% Si	200-460	.0012	.0012	.0012	.0016	.0020	.0024	.0024	.0028	.0031	.0035	.0039	.0043	.0051	.0054
	Synthetics, Duroplastics, Thermoplastics	160-660	.0035	.0039	.0043	.0047	.0055	.0063	.0071	.0075	.0075	.0075	.0075	.0075	.0079	.0079
S	Nickel Alloys and Titanium Alloys	70-130	.0012	.0012	.0012	.0016	.0016	.0020	.0024	.0024	.0024	.0028	.0028	.0028	.0031	.0031

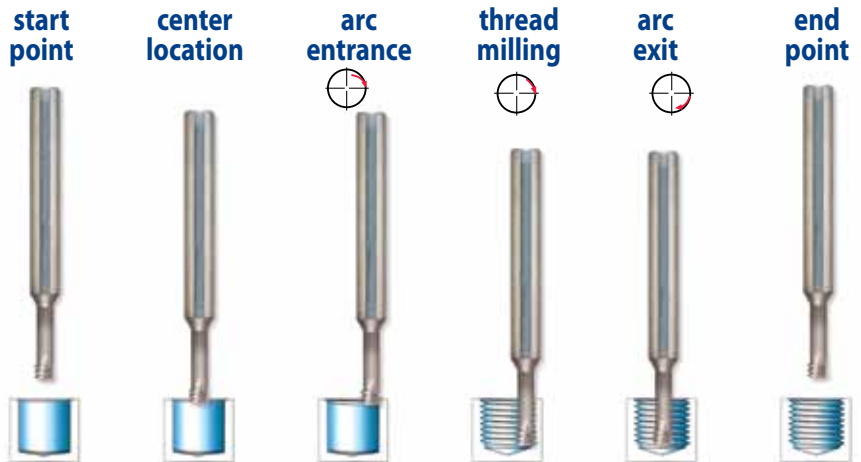

Mini Mill-Thread vs. Taps

Features	Mini Mill-Thread	Taps
Thread surface quality	High	Medium
Thread geometry	Very accurate	Medium
Thread tolerances	4H, 5H, 6H with std cutter	6H with standard tap, 4H with specific tap
Machining time	Same as tap or shorter	Short
Tool breakage	Almost not possible	Could happen often
Machining load	Very low	High
Range of thread diameters	Wide range of diameters	Specific tap for each diameter
Right/Left hand threading	Same cutter	Specific tap for each
Geometric shape	Full profile	Partial profile

MTSB type

Carbide grade - MT7:

Sub-Micron Grade with Titanium Aluminum Nitride multi-layer coating (ISO K10 - K20). This is a general purpose grade, which can be used with all materials; it should be run at medium to high cutting speeds.

ISO Standard	Materials	Cutting Speed ft/min	Feed inch/tooth Cutting Diameter = D					
			Ø.04	Ø.06	Ø.08	Ø.12	Ø.16	Ø.20
P	Low and Medium Carbon Steels < 0.55%C	200 - 390	.0016	.0020	.0020	.0028	.0035	.0043
	High Carbon Steels ≥ 0.55%C	200 - 300	.0012	.0016	.0020	.0024	.0031	.0035
	Alloy Steels, Treated Steels	160 - 260	.0012	.0016	.0016	.0020	.0020	.0024
M	Stainless Steel - Free Cutting	230 - 330	.0008	.0012	.0012	.0016	.0020	.0024
	Stainless Steel - Austenitic	200 - 300	.0008	.0012	.0012	.0016	.0020	.0024
	Cast Steels	230 - 300	.0012	.0016	.0016	.0020	.0020	.0024
K	Cast Iron	130 - 260	.0016	.0020	.0020	.0028	.0035	.0043
N	Aluminum ≤ 12%Si, Copper	330 - 660	.0016	.0020	.0020	.0028	.0035	.0043
	Aluminum > 12%Si	200 - 460	.0012	.0012	.0012	.0016	.0020	.0024
	Synthetics, Duroplastics, Thermoplastics	160 - 660	.0035	.0039	.0043	.0047	.0055	.0063
S	Nickel Alloys, Titanium Alloys.	70 - 130	.0012	.0012	.0012	.0016	.0016	.0020
H	Hardened Steel, 45-50HRc	200 - 230	.0012	.0016	.0016	.0020	.0020	.0024

DMT type

MT7 Sub-Micron Grade with Titanium Aluminum Nitride multi-layer coating (ISO K10 - K20). This is a general purpose grade, which can be used with all materials; it should be run at medium to high cutting speeds.

ISO	Materials	Cutting Speed ft/min	Feed inch/tooth Cutting Diameter=D						
			Ø.16	Ø.20	Ø.24	Ø.31	Ø.35	Ø.39	Ø.47
P	Low and Medium Carbon Steels <0.55%C	200-395	.0012	.0012	.0016	.0020	.0020	.0020	.0020
	High Carbon Steels ≥0.55%C	200-295	.0008	.0012	.0012	.0016	.0016	.0016	.0020
	Alloy Steels, Treated Steels	165-260	.0008	.0008	.0008	.0008	.0012	.0012	.0016
M	Stainless Steels - Free Cutting	230-330	.0008	.0008	.0008	.0008	.0012	.0012	.0012
	Stainless Steels - Austenitic	200-295	.0008	.0008	.0008	.0008	.0012	.0012	.0012
	Cast Steels	230-295	.0008	.0008	.0008	.0008	.0012	.0012	.0016
K	Cast Iron	130-260	.0012	.0012	.0016	.0020	.0020	.0020	.0020
N	Aluminum ≤12%Si, Copper	330-655	.0012	.0012	.0016	.0020	.0020	.0020	.0020
	Aluminum >12% Si	200-460	.0008	.0008	.0008	.0008	.0012	.0012	.0012
	Synthetics, Duroplastics, Thermoplastics	165-655	.0016	.0020	.0020	.0024	.0024	.0024	.0024

DMTH type

MT11 Ultra-fine Sub-Micron grade with advanced PVD triple Blue coating

ISO	Materials	Cutting Speed ft/min	Feed inch/tooth Cutting Diameter=D								
			Ø.08	Ø.12	Ø.16	Ø.20	Ø.24	Ø.31	Ø.35	Ø.39	Ø.47
P	Low and Medium Carbon Steels <0.55%C	190 - 390	.0008	.0008	.0012	.0012	.0016	.0020	.0020	.0020	.0020
	High Carbon Steels ≥0.55%C	190 - 290	.0008	.0008	.0008	.0012	.0012	.0016	.0016	.0016	.0020
	Alloy Steels, Treated Steels	160 - 260	.0008	.0008	.0008	.0008	.0008	.0008	.0012	.0012	.0016
M	Stainless Steels - Free Cutting	230 - 330	.0008	.0008	.0008	.0008	.0008	.0008	.0012	.0012	.0012
	Stainless Steels - Austenitic	190 - 290	.0008	.0008	.0008	.0008	.0008	.0008	.0012	.0012	.0012
	Cast Steels	230 - 290	.0008	.0008	.0008	.0008	.0008	.0008	.0012	.0012	.0016
K	Cast Iron	130 - 260	.0012	.0012	.0012	.0012	.0016	.0020	.0020	.0020	.0020
N	Aluminum ≤10%Si, Copper	330 - 650	.0012	.0012	.0012	.0012	.0016	.0020	.0020	.0020	.0020
	Aluminum >10% Si	190 - 460	.0008	.0008	.0008	.0008	.0008	.0008	.0012	.0012	.0012
	Synthetics, Duroplastics, Thermoplastics	160 - 650	.0016	.0020	.0016	.0020	.0020	.0024	.0024	.0024	.0024
S	Nickel Alloys, Titanium Alloys and High Temp. Alloys	65 - 130	.0008	.0012	.0012	.0016	.0020	.0020	.0024	.0024	.0024
H	Hardened Steels 45-50 HRC	190 - 230	.0008	.0008	.0008	.0012	.0016	.0016	.0020	.0020	.0020
	Hardened Steels 50-55 HRC	160 - 190	.0004	.0004	.0004	.0008	.0012	.0012	.0016	.0016	.0016

Mini Mill-Thread MTSH type

MT9 Sub-Micron Grade with advanced PVD triple coating.

Left hand cutting for CNC code use M04

ISO	Materials	Hardness HRc	Cutting Speed ft/min	Feed inch/tooth Cutting Diameter = D														
				Ø.04	Ø.06	Ø.08	Ø.12	Ø.16	Ø.20	Ø.24	Ø.28	Ø.31	Ø.35	Ø.39	Ø.47	Ø.55	Ø.63	
S	Nickel Alloys, Titanium Alloys and High Temp. Alloys		70-130	.0012	.0012	.0012	.0016	.0016	.0020	.0024	.0024	.0024	.0028	.0028	.0028	.0031	.0031	.0031
H	Hardened Steels	45-50	200-230	.0012	.0016	.0016	.0020	.0020	.0024	.0024	.0028	.0028	.0031	.0031	.0035	.0039	.0039	.0043
		51-55	160-200	.0008	.0012	.0012	.0016	.0016	.0020	.0020	.0024	.0024	.0028	.0028	.0031	.0035	.0039	.0039
		56-62	130-160	.0004	.0008	.0008	.0012	.0012	.0016	.0016	.0020	.0020	.0024	.0024	.0028	.0028	.0031	.0031

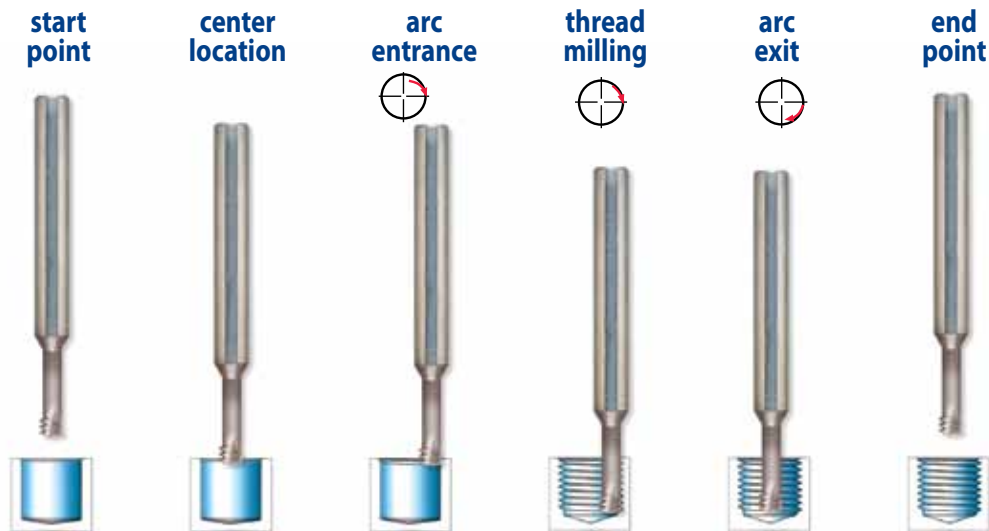

Case Study

Application	Internal Thread M4 X 0.7
Thread Depth	8.0 mm
Workpiece Material	Tool Steel: D2
Hardness	60-62 (HRc)
Cutter Description	MTSH0250C35 0.7 ISO
Machining Conditions	Cutting Speed: 144 ft / min Feed: .0012 Inch / tooth
Machine Control	Mori Seiki VN5000 Fanuc
Cooling Lubricant	Emulsion
Tool Life (No. of Threads)	84

MTH type

MT11 Sub-Micron Grade with advanced PVD triple coating.

ISO	Materials	Hardness HRC	Cutting Speed ft/min	Feed inch/tooth Cutting Diameter = D								
				Ø.10	Ø.12	Ø.16	Ø.20	Ø.24	Ø.28	Ø.31	Ø.35	Ø.39
S	Nickel Alloys, Titanium Alloys and High Temp. Alloys		66-164	.0008	.0008	.0008	.0008	.0012	.0012	.0012	.0012	.0016
H	Hardened Steels Cast Iron	45-50	230-262	.0008	.0012	.0012	.0016	.0016	.0020	.0020	.0024	.0028
		51-55	197-230	.0004	.0008	.0008	.0012	.0012	.0016	.0016	.0020	.0024
		56-62	131-164	.0002	.0004	.0004	.0008	.0008	.0012	.0012	.0016	.0020

For cutters with long cutting length reduce feed rate by 40%

Positioning

Thread Milling

Chamfering



Solid Carbide Grooving Tools

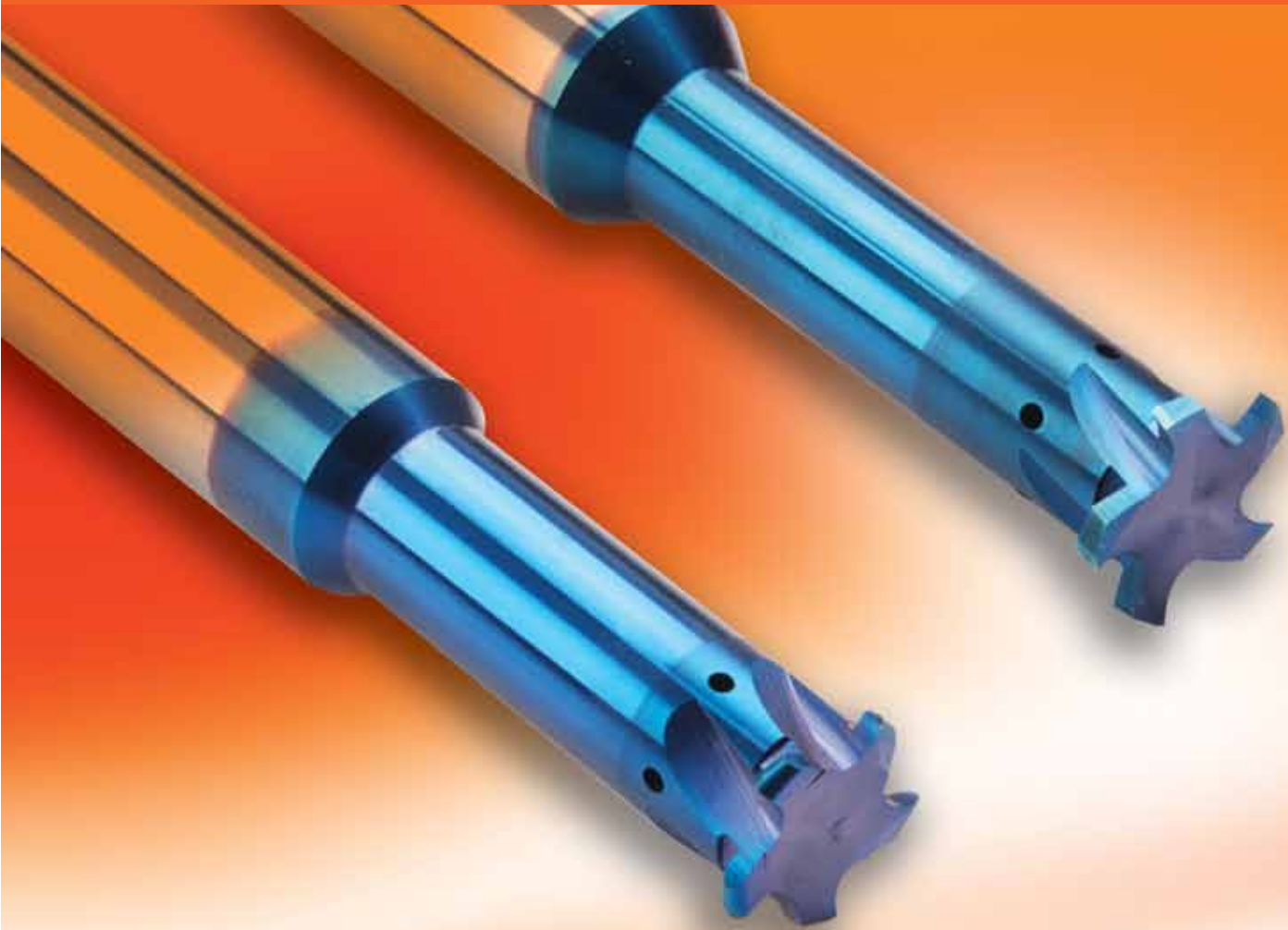

For Grooving Deep Parts

Advantages

Carbide grade: MT8 Sub-micron grade with advanced PVD triple coating (ISO K10-K20). Extremely high heat resistant and smooth cutting operation, For high performance and normal machining conditions. General purpose for all materials.

- Enables machining in deep holes
- Coolant through the flutes is very effective for deep holes.
- Spiral flutes allow smooth cutting action.
- Longer tool life due to special multi-layer coating.
- Shorter machining time due to multi (3 to 5) flutes.

Contents:

Page:

Product Identification	310
Groove Milling with internal coolant through the flutes	311
Full Radius Groove Milling with internal coolant through the flutes	312
Deep Groove Milling	312

Product Identification Groove Milling Ordering Codes

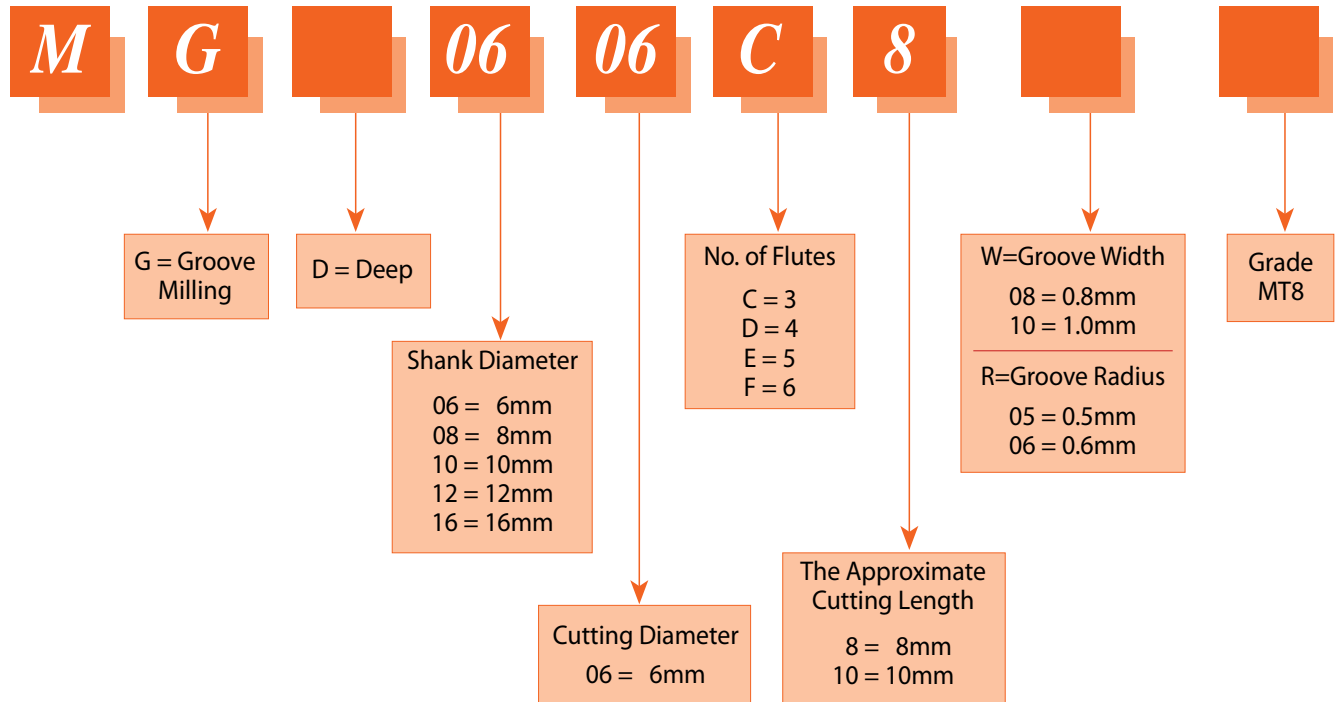

Groove Milling

with internal coolant through the flutes

Tool for Internal Grooving

Metric Shanks

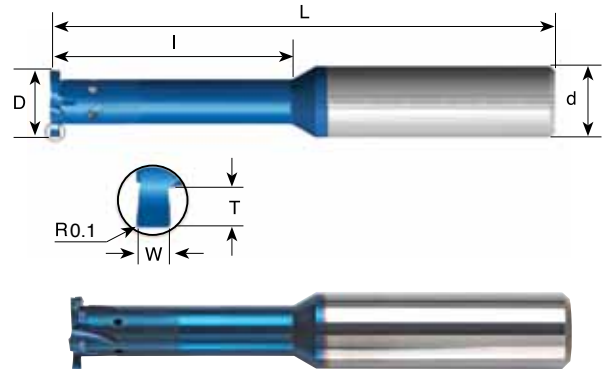

For grooving deep parts

W ±.001	T Max.	Groove Dia. (min.) mm	Ordering Code	d mm	D	No. of Flutes	I	L
.020	.02	$\varnothing > 4$	*MG0604C4 W05	6	.157	3	.17	2.0
.039	.02	$\varnothing > 4$	*MG0604C4 W10	6	.157	3	.17	2.0
.031	.03	$\varnothing > 6$	MG0606C8 W08	6	.236	3	.31	2.3
.039	.04	$\varnothing > 6$	*MG0606C7 W10	6	.236	3	.28	2.3
.059	.04	$\varnothing > 6$	*MG0606C7 W15	6	.236	3	.28	2.3
.039	.05	$\varnothing \geq 7.8$	MG08078D10 W10	8	.307	4	.39	2.5
.059	.06	$\varnothing \geq 7.8$	MG08078D15 W15	8	.307	4	.59	2.5
.079	.06	$\varnothing \geq 7.8$	MG08078D15 W20	8	.307	4	.59	2.5
.047	.06	$\varnothing \geq 9.8$	MG10098D20 W12	10	.386	4	.79	2.9
.059	.08	$\varnothing \geq 9.8$	MG10098D20 W15	10	.386	4	.79	2.9
.079	.08	$\varnothing \geq 9.8$	MG10098D20 W20	10	.386	4	.79	2.9
.059	.09	$\varnothing \geq 12$	MG1212E30 W15	12	.472	5	1.18	3.3
.079	.09	$\varnothing \geq 12$	MG1212E30 W20	12	.472	5	1.18	3.3
.118	.09	$\varnothing \geq 12$	MG1212E30 W30	12	.472	5	1.18	3.3
.055	.07	$\varnothing \geq 16$	MG1616E30 W14	16	.630	5	1.18	4.0
.067	.08	$\varnothing \geq 16$	MG1616E40 W17	16	.630	5	1.57	4.0
.077	.09	$\varnothing \geq 16$	MG1616E45 W19	16	.630	5	1.77	4.0

Order example: MG 10098D20 W12 MT8

* Tools without coolant

Full Radius Groove Milling

with internal coolant through the flutes

Tool for Internal Grooving

Metric Shanks

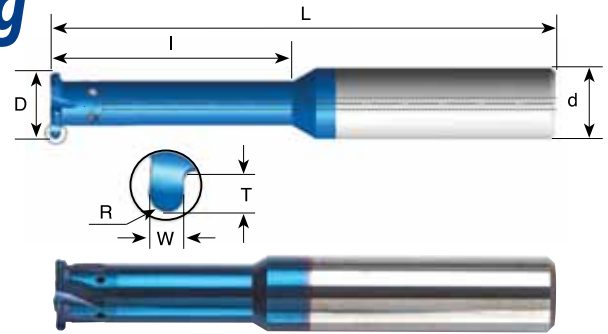

For grooving deep parts

R	W ±.001	T Max.	Groove Dia. (min.) mm	Ordering Code	d mm	D	No. of Flutes	I	L
.020	.039	.02	Ø > 4	*MG0604C4 R05	6	.157	3	.17	2.0
.020	.039	.03	Ø > 6	MG0606C8 R05	6	.236	3	.31	2.3
.030	.059	.04	Ø > 6	*MG0606C7 R075	6	.236	3	.28	2.3
.020	.039	.04	Ø ≥ 8.8	MG10088D16 R05	10	.346	4	.63	2.9
.024	.047	.04	Ø ≥ 10	MG1010D20 R06	10	.394	4	.79	2.9
.030	.059	.08	Ø ≥ 10	MG1010D20 R075	10	.394	4	.79	2.9
.020	.079	.08	Ø ≥ 10	MG1010D20 R10	10	.394	4	.79	2.9
.035	.071	.06	Ø ≥ 12	MG1212D30 R09	12	.472	4	1.18	3.3
.039	.079	.06	Ø ≥ 16	MG1616E40 R10	16	.630	5	1.57	4.0
.059	.118	.09	Ø ≥ 16	MG1616E40 R15	16	.630	5	1.57	4.0

Order example: MG 1010D20 R06 MT8

* Tools without coolant

Deep Groove Milling

with internal coolant bore

Metric Shanks



Ordering Code	W ±0.001	R	T (max.)	Groove Dia. (min.) mm	d mm	D	No. of Flutes	L
MGD 10195 F W15	.059	.004	.18	Ø > 19.5	10	.768	6	5.0
MGD 10195 F W20	.079	.004	.18	Ø > 19.5	10	.768	6	5.0
MGD 10195 F W30	.118	.004	.18	Ø > 19.5	10	.768	6	5.0
MGD 10195 F W35	.138	.004	.18	Ø > 19.5	10	.768	6	5.0
MGD 10195 F W40	.157	.004	.18	Ø > 19.5	10	.768	6	5.0
MGD 10195 F W50	.197	.004	.18	Ø > 19.5	10	.768	6	5.0

Supercut Roughers



New Innovative High Performance Roughing end-mills specifically designed for high volume machining applications.
Multi-Flute, semi-finish profile and center cutting.
Provide high metal removal rates in Slotting, Shouldering and Helical Plunging operations.

Features

- High Performance Cutting (HPC)
- Innovative roughing geometry produces smaller chips
- Low cutting forces
- Extremely high material removal rate
- Reinforced corner chamfer, promotes additional strength for longer tool life
- Designed to machine difficult and abrasive materials

Carbide Grade: CR3 Ultra-Fine carbide grade with high hardness and toughness provides high cutting edge stability and wear resistance.

A **New Generation** of PVD Coating for High-Performance Cutting Applications.

Contents:	Page:	Contents:	Page:
Product Identification	314	Steel Toolholders	319
CR-Supercut Roughers	315	Carbide Shank Toolholder	319
Coated Solid Carbide Roughers		Solid Carbide Roughers for Aluminum Machining	
Short Design	316	Without Internal Coolant	320
Long Design	316	With Internal Coolant through the Flutes	321
With Neck	317	Cutting Data	322
CMT Roughers			
Inserts	318		

Product Identification Ordering Codes

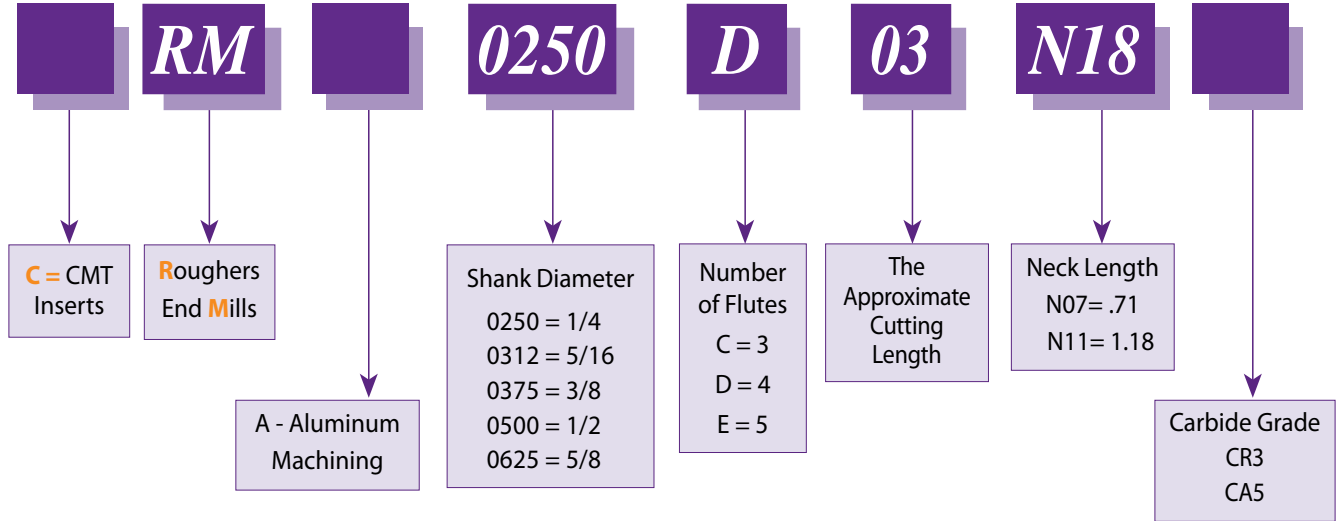

CR-Supercut Roughers

Carmex solid carbide Roughers are new innovative high performance end mills. Specifically designed for high volume machining applications. Multi-flute, semi-finish profile and center cutting. Provides high metal removal rates in Slotting, Shouldering and Helical Plunging operations.

Features

- High Performance Cutting (HPC)
- Innovative roughing geometry produces smaller chips
- Low cutting forces
- Extremely high material removal rate
- Reinforced corner chamfer, promotes additional strength for longer tool life
- Designed to machine difficult and abrasive materials



Carbide Grade: CR3

Ultra-Fine carbide grade with high hardness and toughness provides high cutting edge stability and wear resistance.

A **New Generation** of PVD Coating for High-Performance Cutting Applications.

Solid Carbide Roughers

Short Design

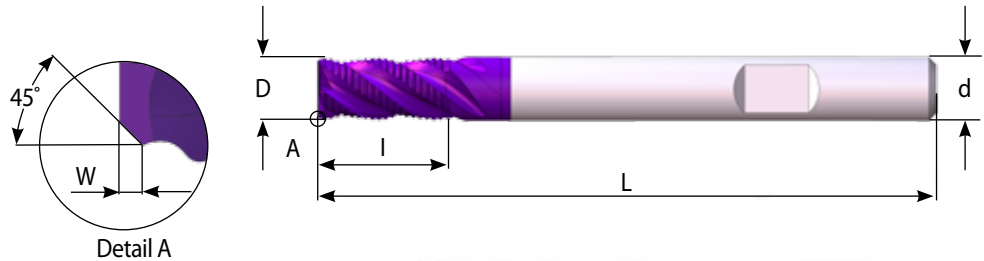

P	M	K	N	S	H
●	●	●	○	●	≤56 HRC

Ordering Code	d	D	W	No. of Flutes	I	L
RM 0250 C02	1/4	.118	.008	3	.20	2.5
RM 0250 C03	1/4	.157	.012	3	.35	2.5
RM 0250 D03	1/4	.197	.012	4	.39	2.5
RM 0250 D04	1/4	.250	.012	4	.39	2.5
RM 0312 D04	5/16	.312	.012	4	.47	2.5
RM 0375 D05	3/8	.375	.012	4	.55	3.0
RM 0500 D06	1/2	.500	.016	4	.63	3.5
RM 0625 E10	5/8	.625	.020	5	1.06	4.0

● First choice ○ Alternative

Long Design



Ordering Code	d	D	W	No. of Flutes	I	L
RM 0250 D06	1/4	.250	.012	4	.63	2.5
RM 0312 D06	5/16	.276	.012	4	.63	2.5
RM 0312 D07	5/16	.312	.012	4	.71	2.5
RM 0375 D08	3/8	.375	.012	4	.87	3.0
RM 0500 D10	1/2	.500	.016	4	1.02	3.5

Solid Carbide Roughers with Neck

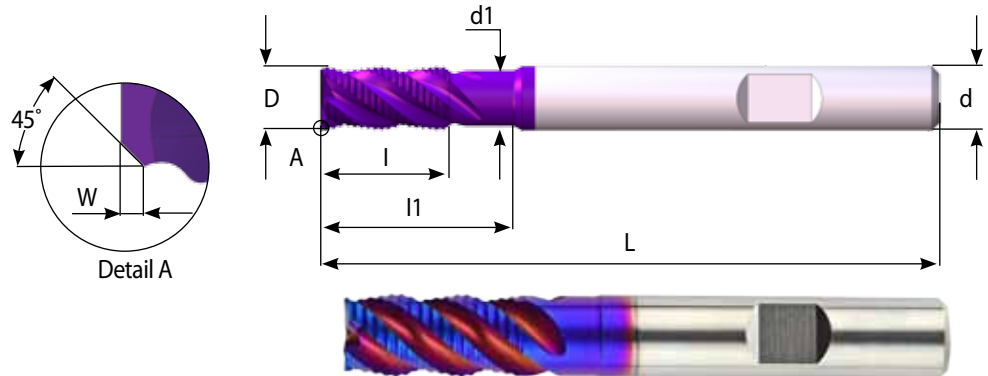

P	M	K	N	S	H
●	●	●	○	●	≤56 HRc

Ordering Code	d	D	I	l1	d1	W	No. of Flutes	L
RM 0250 D05 N07	1/4	.250	.51	.71	.23	0.12	4	2.5
RM 0312 D06 N09	5/16	.312	.67	.94	.30	0.12	4	2.5
RM 0375 D08 N11	3/8	.375	.83	1.18	.38	0.12	4	3.0
RM 0500 D09 N14	1/2	.500	.98	1.42	.46	0.16	4	3.5
RM 0625 E13 N18	5/8	.625	1.30	1.89	.61	0.20	5	4.0

● First choice ○ Alternative

CMT Roughers

Indexable CMT roughers for excellent performance

- Solid and accurate clamping method enables full repeatability
- Working at high machining parameters
- Modular system using the standard CMT tool holders with various shank options
- Enables machining with large overhang

Carbide Grade: CR3

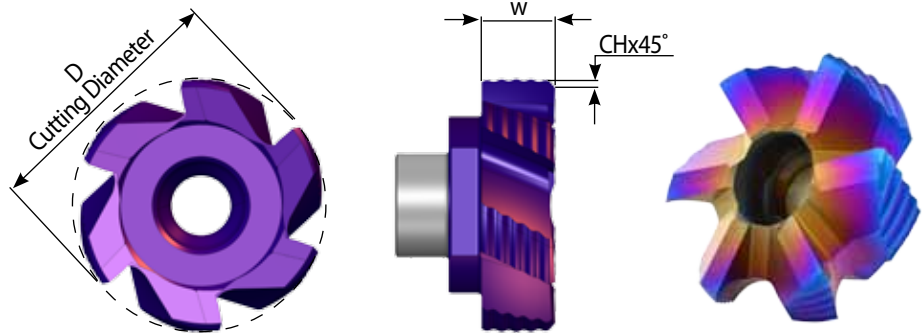

P	M	K	N	S	H
●	●	●	○	●	≤56 HRc

Insert Type	Ordering Code	D	No. of Flutes	W	CH
S20	CRM160 F W50	.63	6	.197	.016
S20	CRM170 F W50	.67	6	.197	.016
S20	CRM200 F W50	.79	6	.197	.016

● First choice ○ Alternative

The CMT Roughers should be used with all the toolholders shown on page 318.

Steel Toolholders With internal coolant

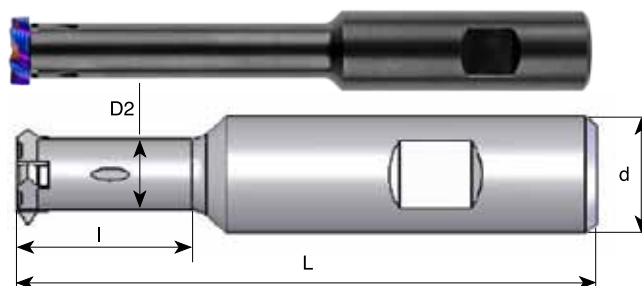

Ordering Code	Insert Type	d	D2	l	L	Insert Screw	Torx Key
SRC 0625 H18	S20	.625	.54	1.89	4.0	S16	K16
SRC 0750 H18	S20	.750	.54	1.26	4.0	S16	K16
SRC 0750 J18	S20	.750	.54	1.89	4.5	S16	K16
SRC 0750 L18	S20	.750	.54	2.91	5.5	S16	K16

Carbide Shank Toolholder With internal coolant

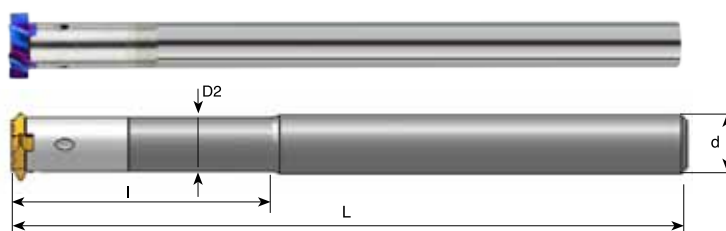

Ordering Code	Insert type	d	D2	l	L	Insert Screw	Torx Key
CRC 0500 P18	S20	.500	.500	---	7.0	S16	K16
CRC 0625 L18 R18	S20	.625	.54	1.89	7.8	S16	K16
CRC 0625 L29 R18	S20	.625	.54	2.91	7.8	S16	K16

Solid Carbide Roughers - *Aluminum Machining*

Features

- High Performance Cutting (HPC).
- Optimal flute geometry delivers maximum metal removal rates and better chip evacuation.
- Low cutting forces.
- Reinforced corner chamfer, promotes additional strength for longer tool life.
- Uncoated smooth polished surface finish.

Carbide Grade: CA5

Ultra-Fine carbide grade with high hardness and toughness provides high cutting edge stability and wear resistance.

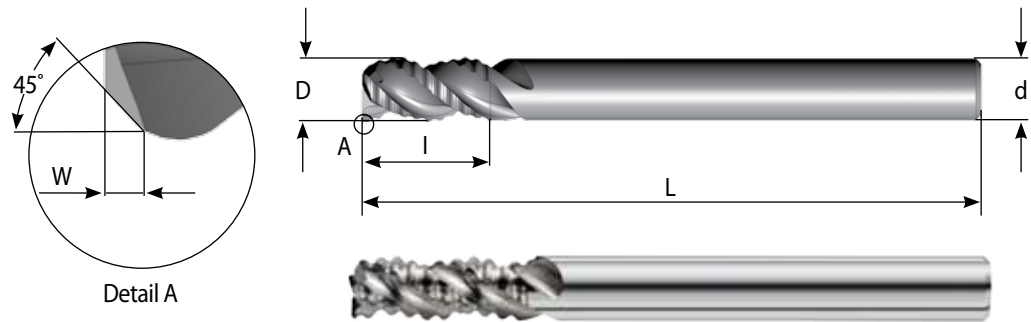

P	M	K	N	S	H
	○	○	●	○	

Ordering Code	d	D	W	No. of Flutes	I	L
RMA 0250 C03	1/4	.157	.012	3	.31	2.5
RMA 0250 C06	1/4	.250	.012	3	.63	2.5
RMA 0312 C07	5/16	.312	.012	3	.75	2.5
RMA 0375 C08	3/8	.375	.012	3	.87	3.0
RMA 0500 C10	1/2	.500	.016	3	1.02	3.5

● First choice ○ Alternative

Solid Carbide Roughers - *Aluminum Machining*

with internal coolant through the flutes

Features

- High Performance Cutting (HPC)
- The coolant washes the chip out

Carbide Grade: CA5

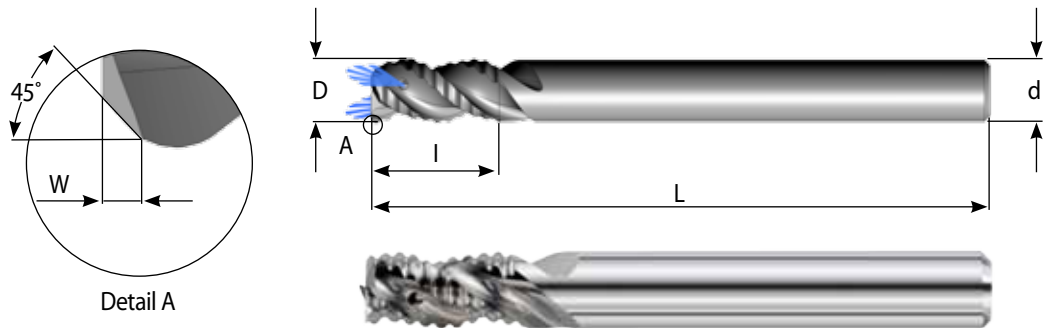

P	M	K	N	S	H
	○	○	●	○	

Ordering Code	d mm	D	W	No. of Flutes	I	L
RMA 0606 C16 Z	6	.236	.012	3	.63	2.3
RMA 0808 C19 Z	8	.315	.012	3	.75	2.5
RMA 1010 C22 Z	10	.394	.012	3	.87	2.9
RMA 1212 C26 Z	12	.472	.016	3	1.02	3.3

Mini Chamfer



Advantages

Carbide grade: MT8 Sub-micron grade with advanced PVD triple coating (ISO K10-K20). Extremely high heat resistant and smooth cutting operation, for high performance, and normal machining conditions. General purpose for all materials.

- Optimal for deburring, back chamfering and grooving.
- Double side cutting.
- Spiral flute allows smooth cutting action.

Contents:

Page:

Product Identification	324
Mini Chamfer	325-326
Mini Chamfer Kit	327
Special Solid Carbide Tools	327

Product Identification

Mini Chamfer Ordering Codes

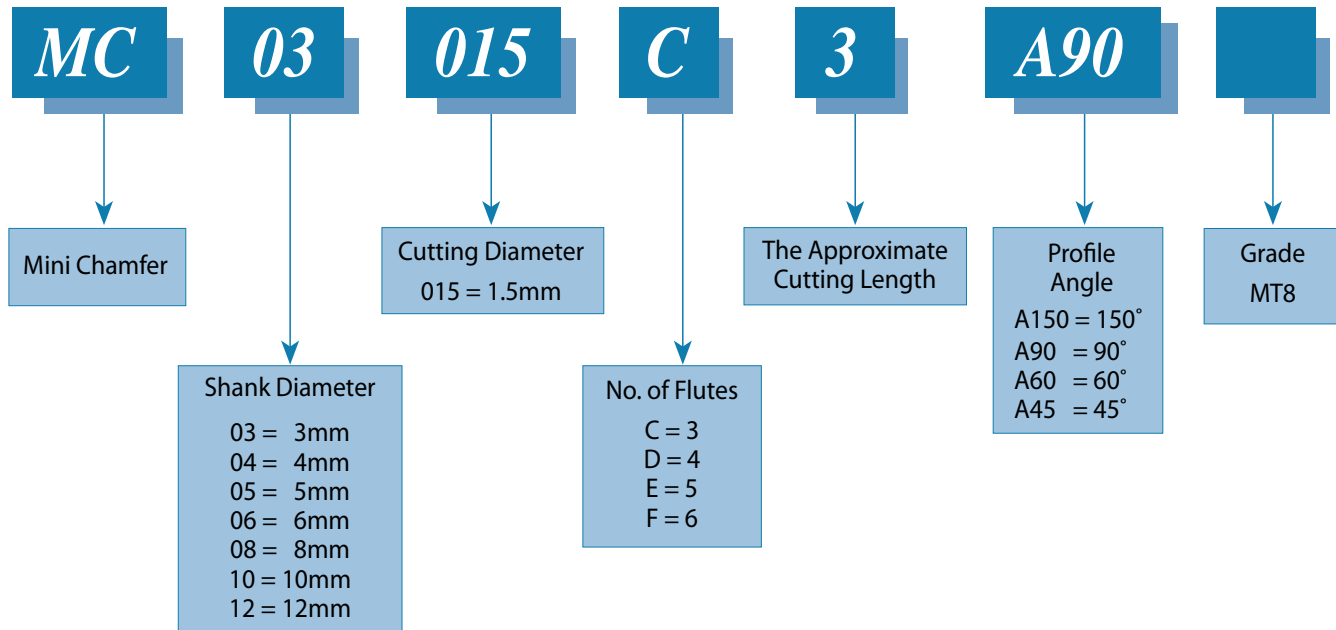

Mini Chamfer

Metric Shanks

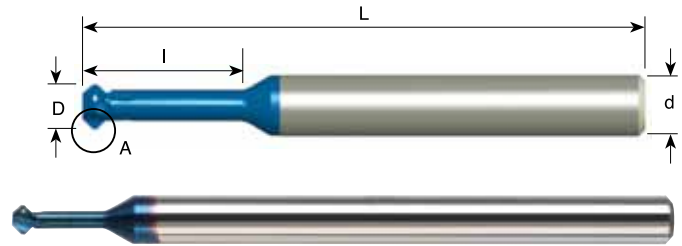
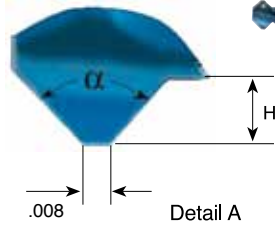

90°

Ordering Code	d mm	D	I	H	α	No. of Flutes	L
MC03015C3 A90	3	.059	.15	.012	90°	3	1.5
MC0302C5 A90	3	.079	.20	.016	90°	3	1.5
MC03025C6 A90	3	.098	.25	.020	90°	3	1.5
MC0303C7 A90	3	.118	.30	.024	90°	3	1.5
MC04035C9 A90	4	.138	.35	.028	90°	3	2.0
MC0404C10 A90	4	.157	.39	.031	90°	3	2.0
MC05045C11 A90	5	.177	.44	.039	90°	3	2.0
MC0505C12 A90	5	.197	.49	.043	90°	3	2.0
MC06055C13 A90	6	.217	.54	.047	90°	3	2.0
MC0606C15 A90	6	.236	.59	.059	90°	3	2.0

Long Reach 90°

Ordering Code	d mm	D	I	H	B	α	No. of Flutes	L
MC0303C12 A90	3	.118	.47	.024	.028	90°	3	1.5
MC04035C14 A90	4	.138	.55	.028	.031	90°	3	2.0
MC0404C16 A90	4	.157	.63	.031	.035	90°	3	2.0
MC0404C16L A90	4	.157	.63	.031	.035	90°	3	4.1
MC05045C18 A90	5	.177	.71	.039	.043	90°	3	2.0
MC0505C20 A90	5	.197	.79	.043	.047	90°	3	2.0
MC0505C20L A90	5	.197	.79	.043	.047	90°	3	4.1
MC06055C22 A90	6	.217	.87	.047	.051	90°	3	2.3
MC0606C24 A90	6	.236	.94	.059	.063	90°	3	2.3
MC0606C24L A90	6	.236	.94	.059	.063	90°	3	4.1
MC0808D28 A90	8	.315	1.10	.063	.067	90°	4	2.5
MC0808D28L A90	8	.315	1.10	.063	.067	90°	4	4.1
MC1010E35 A90	10	.394	1.38	.071	.075	90°	5	2.9
MC1212F42 A90	12	.472	1.65	.083	.087	90°	6	3.3

60°

Ordering Code	d mm	D	I	H	α	No. of Flutes	L
MC0302C5 A60	3	.079	.20	.016	60°	3	1.5
MC0303C7 A60	3	.118	.30	.024	60°	3	1.5
MC04035C9 A60	4	.138	.35	.028	60°	3	2.0
MC0404C10 A60	4	.157	.39	.031	60°	3	2.0
MC05045C11 A60	5	.177	.44	.039	60°	3	2.0
MC0505C12 A60	5	.197	.49	.043	60°	3	2.0

Mini Chamfer Metric Shanks

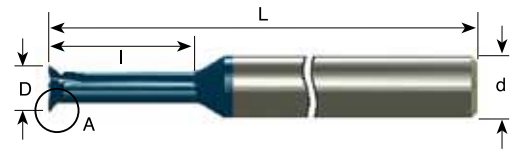
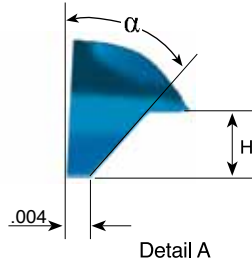
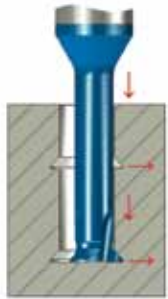

Dovetail 45°*

Ordering Code	d mm	D	l	H	α	No. of Flutes	L
MC03015C4 A45	3	.059	.18	.012	45°	3	1.5
MC0302C6 A45	3	.079	.24	.016	45°	3	1.5
MC03025C7 A45	3	.098	.30	.020	45°	3	1.5
MC0303C12 A45	3	.118	.47	.024	45°	3	1.5
MC04035C14 A45	4	.138	.55	.028	45°	3	2.0
MC0404C16 A45	4	.157	.63	.031	45°	3	2.0
MC05045C18 A45	5	.177	.71	.039	45°	3	2.0
MC0505C20 A45	5	.197	.79	.043	45°	3	2.0
MC06055C22 A45	6	.217	.87	.047	45°	3	2.3
MC0606C24 A45	6	.236	.94	.059	45°	3	2.3

* One side cutting

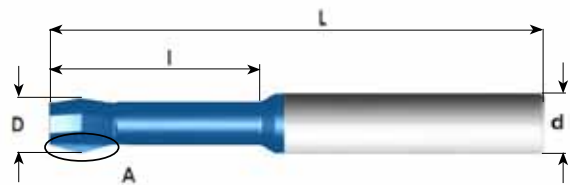
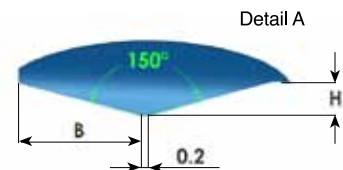
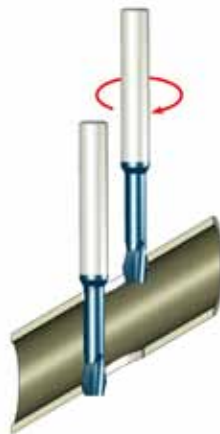

150°

Ordering Code	d mm	D	l	H	B	No. of Flutes	L
MC0303C12 A150	3	.118	.47	.024	.087	3	1.5
MC0404C16 A150	4	.157	.63	.031	.118	3	2.0
MC0404C16L A150	4	.157	.63	.031	.118	3	4.1
MC0505C20 A150	5	.197	.79	.039	.150	3	2.0
MC0505C20L A150	5	.197	.79	.039	.150	3	4.1
MC0606C24 A150	6	.236	.94	.039	.150	3	2.3
MC0606C24L A150	6	.236	.94	.039	.150	3	4.1
MC0808C28 A150	8	.315	1.10	.039	.150	3	2.5
MC0808C28L A150	8	.315	1.10	.039	.150	3	4.1

Order example: MC 0303 C12 A150 MT8

Cutting Data for tools MG, MC family

ISO Standard	Materials	Cutting Speed ft/min	Feed inch/tooth Cutting Diameter = D												
			Ø.06	Ø.08	Ø.12	Ø.16	Ø.20	Ø.24	Ø.28	Ø.31	Ø.35	Ø.39	Ø.47	Ø.55	Ø.63
P	Low & Medium Carbon Steels < 0.55%C	200 - 390	.0011	.0014	.0019	.0025	.0030	.0036	.0039	.0041	.0044	.0044	.0047	.0050	.0050
	High Carbon Steels ≥0.55%C	200 - 390	.0008	.0014	.0017	.0022	.0025	.0028	.0033	.0036	.0039	.0039	.0044	.0047	.0050
	Alloy Steels, Treated Steels	160 - 260	.0008	.0011	.0014	.0014	.0017	.0019	.0019	.0022	.0025	.0028	.0033	.0036	.0039
M	Stainless Steel-Free Cutting	230 - 330	.0006	.0008	.0011	.0014	.0017	.0017	.0019	.0022	.0025	.0028	.0030	.0033	.0036
	Stainless Steel-Austenitic	200 - 300	.0006	.0008	.0011	.0014	.0017	.0017	.0019	.0022	.0025	.0028	.0030	.0033	.0036
	Cast Steels	230 - 300	.0008	.0011	.0014	.0014	.0017	.0019	.0019	.0022	.0025	.0028	.0033	.0036	.0039
K	Cast Iron	130 - 260	.0011	.0014	.0019	.0025	.0030	.0036	.0039	.0041	.0044	.0044	.0047	.0050	.0050
N	Aluminum ≤12%Si, Copper	330 - 660	.0011	.0014	.0019	.0025	.0030	.0036	.0039	.0041	.0044	.0044	.0047	.0050	.0050
	Aluminum >12%Si	200 - 460	.0008	.0008	.0011	.0014	.0017	.0017	.0019	.0022	.0025	.0028	.0030	.0036	.0037
	Synthetics, Duroplastics, Thermoplastics	160 - 660	.0025	.0030	.0033	.0039	.0044	.0050	.0052	.0052	.0052	.0052	.0052	.0055	.0055
S	Nickel Alloys, Titanium Alloys	70 - 130	.0008	.0008	.0011	.0011	.0014	.0017	.0017	.0017	.0019	.0019	.0019	.0022	.0022

Mini Chamfer Kit

Kit KMC	Qty
MC 0303 C12 A90	1
MC 03025 C6 A90	1
MC 0404 C10 A90	1
MC 04035 C9 A90	1
MC 05045 C11 A90	1
MC 0606 C24 A90	1



Special Solid Carbide Tools



As part of being a service-orientated company, Carmex produces specials according to customer's requirements. Special tools are supplied in short delivery times.





© Copyright Carmex Precision Tools Ltd. 2017



CARMEX FCE 8/2017 INCH



**Carmex**
Precision Tools Ltd.
The optimal tools for your industry™



Carmex Precision Tools LLC
2075 Hwy 175, Richfield, WI 53076,
Phone: 888 628-5030, Fax: 888 628-5302
E-mail: sales@carmexusa.com Website: www.carmexusa.com