

L-150
Lever Type
Load Binder

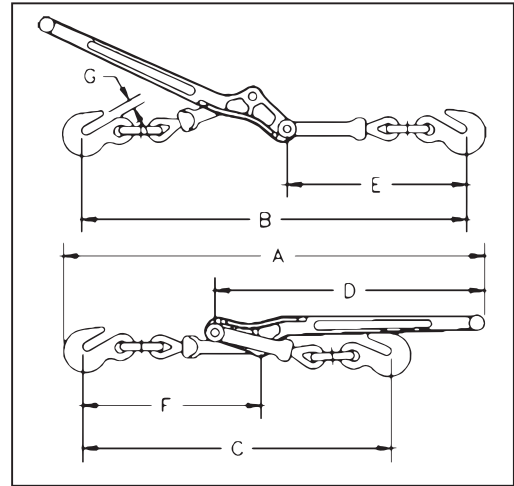

- Extra heavy construction at leverage point to prevent spreading. Heel of binder toggles away from load, permitting easy release.
- Ball and socket swivel joints at hook assemblies permit a straight line pull.
- Binders shown with Proof Loads have been individually proof tested to values shown, prior to shipment.
- Meets or exceeds requirements of US DOT FMCSA Part 393 Subpart I.

Load Rated®



SEE APPLICATION AND WARNING INFORMATION
On Pages 271
Para Español: www.thecrosbygroup.com

L-150 Standard Lever Type Load Binders

Model	Stock No.	Std. Pkg.	Min-Max Chain Size (in.)	Working Load Limit (lbs.)	Proof Load (lbs.)	Ultimate Load (lbs.)	Weight Each (lbs.)	Handle Length (in.)	Take Up (in.)	Dimensions (in.)						
										A	B	C	D	E	F	G
7-1	1048128	4	5/16-3/8	5400	10800	19000	7.02	16.00	4.50	24.13	22.13	17.88	16.00	10.38	10.38	.50
A-1	1048146	4	3/8-1/2	9200	18400	33000	12.47	18.69	4.50	28.75	25.75	21.25	18.69	12.31	12.38	.63
C-1	1048164	4	1/2-5/8	13000	26000	46000	19.68	21.00	4.75	31.25	29.75	25.00	21.00	14.63	13.75	.72

WESTECH RIGGING SUPPLY

Call Toll Free: 800-442-7475

Call Us or Visit Our Stores:
Monday - Friday, 8:00am - 5:30pm Pacific



Distributed By

Visit Us Online at: www.WestechRigging.com

4140 West 11th Avenue
Eugene, Oregon 97402

2439 McGilchrist St SE
Salem, Oregon 97302

Lebus® Load Binders

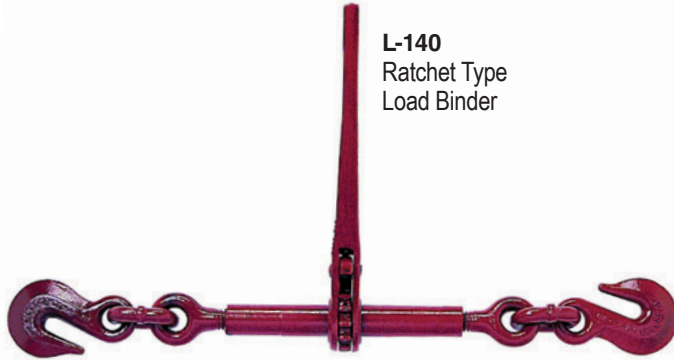

L-140
Ratchet Type
Load Binder

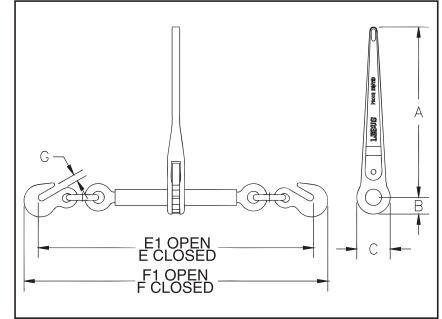

- Upgraded for use with Grades 70, 80 and 100 Chain.
- Utilizes standard Crosby A-323 Alloy Eye Grab Hooks.
- New design "one piece" forged handle.
- Continuous take-up feature provides finite adjustment to tie down load.
- One piece assembly, no bolts or nuts to loosen.
- Ratchet spring is rust proofed.
- All load bearing or holding parts forged.
- Easy operating positive ratchet.
- Binders shown with Proof Loads have been individually proof tested to values shown, prior to shipment.
- Meets or exceeds requirements of US DOT FMCSA Part 393 Subpart I.



Load Rated®

L-140 Standard Ratchet Type Load Binders (Meets or exceeds requirements of US DOT FMCSA Part 393 Subpart I.)

Model	Stock No.	Min-Max Chain Size (in.)	Working Load Limit (lbs.)*	Proof Load (lbs.)	Weight Each (lbs.)	Handle Length (in.)	Barrel Length (in.)	Take Up (in.)	Dimensions (in.)							
									A	B	C	E	E1	F	F1	G
R-7 **	1048404	5/16-3/8	8800	17600	12.11	14	10	8.0	14.00	1.38	2.75	22.94	30.94	25.13	33.13	.50
R-A **	1048422	3/8-1/2	15000	30000	14.70	14	10	8.0	14.00	1.38	2.75	25.25	33.25	27.63	35.63	.63
R-C ***	1048440	1/2-5/8	16000	32000	14.55	14	10	8.0	14.00	1.38	2.75	26.38	34.38	29.44	37.44	.72

* Ultimate Load is 3 times the Working Load Limit. ** Matches the Working Load Limit of Grade 100 chain for both sizes. *** Matches the Working Load Limit of Grade 100 chain for 1/2" size.

Chain & Accessories



Lebus® LOAD BINDER

WARNINGS & APPLICATION INSTRUCTIONS

WARNING

- Failure to use this load binder properly may result in serious injury or even death to you or others.
- Do not operate load binder while standing on the load.
- Move handle with caution. It may whip – Keep body clear.
- Keep yourself out of the path of the moving handle and any loose chain laying on the handle.
- You must be familiar with state and federal regulations regarding size and number of chain systems required for securing loads on trucks.
- Always consider the safety of nearby workers as well as yourself when using load binder.
- While under tension, load binder must not bear against an object, as this will cause side load.
- Do not throw these instructions away. Keep them close at hand and share them with any others who use this load binder.
- Do not use handle extender – see instructions.
- Do not attempt to close or open the binder with more than one person.

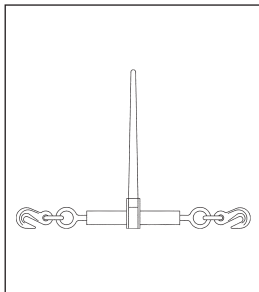

Ratchet Type

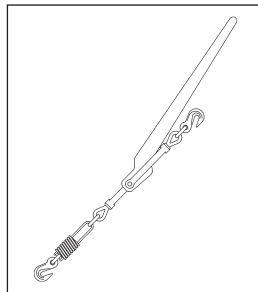

Lever Snubbing Type

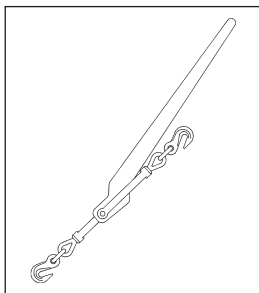

Lever Type

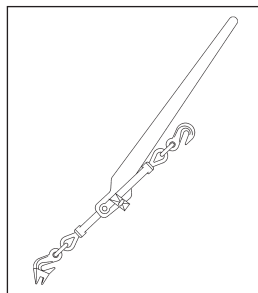

Lever Walking Type

Mechanical Advantage

Lever Type Binder = 25 : 1

Ratchet Type Binder = 50 : 1

Example: 100 pounds of effort applied to the binder results in the following force on the binder.

Lever Type:

100 lbs. x 25 = 2500 lbs. of force

Ratchet Type:

100 lbs. x 50 = 5000 lbs. of force

Instructions – Lever Type Load Binders

- Hook load binder to chain so you can operate it while standing on the ground. Position load binder so its handle can be pulled downward to tighten chain (see photo). **Be aware of ice, snow, rain, oil, etc. that can affect your footing. Make certain your footing is secure.**
- The Crosby Group LLC specifically recommends AGAINST the use of a handle extender (cheater pipe). If sufficient leverage cannot be obtained using the lever type load binder by itself, a ratchet type binder should be used.
- If the above recommendation is disregarded and a cheater pipe is used, it must closely fit the handle and must slide down the handle until the handle projections are contacted. The pipe should be secured to the handle, for example, by a pin, so that the pipe cannot fly off the handle if you lose control and let go. The increased leverage, by using a cheater pipe, can cause deformation and failure of the chain and load binder.
- During and after tightening chain, check load binder handle position. **Be sure** it is in the locked position and that its bottom side touches the chain link.
- Chain tension may decrease due to load shifting during transport. To be sure the load binder remains in proper position: Secure handle to chain by wrapping the loose end of chain around the handle and the tight chain, or tie handle to chain with soft wire.
- When releasing load binder, remember there is a great deal of energy in the stretched chain. This will cause the load binder handle to move very quickly with great force when it is unlatched. **Move handle with caution. It may whip – Keep body clear.**
- **Never use a cheater pipe or handle extender to release handle.** Use a steel bar and pry under the handle and stay out of the path of handle as it moves upward.
- If you release the handle by hand, use an open hand under the handle and push upward. **Do not close your hand around the handle. Always keep yourself out of the path of the moving handle.**



Chain & Accessories

Instructions - Ratchet Load Binders

- Position ratchet binder so it can be operated from the ground.
- **Make sure your footing is secure.**

Maintenance of All Load Binders

- Routinely check load binders for wear, bending, cracks, nicks, or gouges. **If visual wear bending or cracks are present - Do not use load binder.**
- Routinely lubricate pivot and swivel points of Lever Binders, and pawl part and screw threads of Ratchet Binders to extend product life and reduce friction wear.