

• CUSTOMER SERVICE • INNOVATION • MANUFACTURING • QUALITY • TECHNICAL EXPERTISE • EXCELLENCE • DESIGN •



The Right Connection™

Hose & Coupling Directory

Customer Service: **+44 (0)1772 323 529**

www.dixoneurope.co.uk

Air Fittings



"Air King" Universal Couplings & Clamps, European Compressor Couplings, Quick Release Couplings, King Cable Safety Hose Restraints, Whipchecks, Blow Guns.

A

Cam & Groove



Dixon A-A-5932B Specification, DIN, Andrews, Boss-lock, EZ Boss, Line Drawings, High Pressure Snow Cannon Range, King Crimp Style, Seals & Gaskets, Reducing Couplers, Adapters, Replacement Handles, Accessories

B

Clamps & Accessories



Heavy Duty & Spiral Clamps, Worm Gear, K Series, Single & Double Bolt Clamps, Aero Seal and Preformed Band Clamps, Hi-Torque, T-Bolt, Band It™, Safety Clamps, Clamping Tools

C

Hose & Hose Assemblies



Rubber, PVC and Composite Hose for Air/Water, Oil, Chemical, General Purpose and Food Applications, Bulkstream – Custom Built Hose, Metallic & PTFE, Specialist Armoured, Hose Protection and Jackets.

F

Hygienic Products



Couplings (DIN, RJT, SMS, IDF, Tri-Clamp), Clamps, Gaskets, Elbows, Tees, Ferrules, Reducers, Valves (Butterfly, Ball & Check), Sight Glasses, BPE Biopharm, Dairy, Actuated Valves, Bespoke Fabricated Configurations.

G

Permanently Attached Couplings - Holedall®



Internal Expansion, External Crimp, External Swage, Stems, Ferrules, Hygienic, API Certified Fittings, Concrete Placement & Offshore Range, Rotary & High Pressure, Hose Lifter, Hammer Unions, Swaging Machines & Accessories.

H

Tanker, Overfill & Storage Tank Products



Petroleum and Dry Bulk Fittings, Adapters & Couplers, API Valves, Caps, FloTech™ Overfill Prevention, Nozzles, Pressure & Vacuum Valves, Reducers, Tank Truck Fittings, Storz, Swivel Joints, Dry Quick Disconnect Couplings.

K

Valves - General & Industrial



Ball Valves, Gate Valves, Polypropylene Valves, Foot Valves, Skimmers & Strainers, Safety Check Valves, Locking Ball. (for other valves see section G & K)

L

Water Couplings

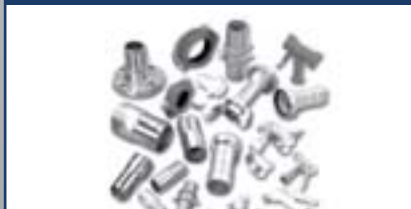

Agri Lock, Bauer Type, Hinge Lock, Victaulic, Geka Type, King Shank, King Combination Nipples, King Crimp Style, Wash Down Guns. (for Swivel Joints see section K)

M

Fire Products - Dixon Powhatan



Fire Protection Valves, Fire Department Connections, Mill Hose, Rack Hose, Hydrant Adapters, Expansion Rings, Hydrant Nozzles, Hose Couplings, Single & Double Jackets
(for Storz fittings see section K)

D

Fittings, Gauges & Adapters



Pipe Fittings, Flanges, Smooth Tails, Instrumentation Fittings, Reducers, Threaded Adapters, Plugs, Swivel Adapters, Crimp Ferrules, Crimping Tools, Plastic Fittings, Brass Fittings

E

Quick Release Couplings



Quick Release Couplings for hydraulic and pneumatic applications. Interchanges with ISO A, ISO B, Snap-Tite, Rectus, MacDonald, Cjen, Parker. High Pressure Blow Out Preventors.

I

Steam Couplings - Boss™



Boss Coupling System, Boss Ground Joint Seal Coupling, Boss Stem & Wing Nuts, Boss Spud Adapters, Boss Adapters & Hose Menders, Boss Clamps, Steam Hose Fittings BS EN 14423:2004.

J

Technical & Safety Information



N

www.dixoneurope.co.uk



Air Fittings

page
4

A

Cam & Groove

page
22

B

Clamps & Accessories

page
58

C

Fire Products -
Dixon Powhatan

page
76

D

Fittings, Gauges
& Adapters

page
80

E

Hose &
Hose Assemblies

page
100

F

Hygienic Products

page
138

G

Permanently Attached
Couplings - Holedall®

page
238

H

Quick Release
Couplings

page
268

I

Steam Couplings -
Boss™

page
336

J

Tanker, Overfill &
Storage Tank Products

page
348

K

Valves -
General & Industrial

page
402

L

Water Couplings

page
416

M

Technical & Safety
Information

page
442

N

A



Air Fittings

N Series Quick Release Couplings - Bowes/MacDonald Interchange ...	6-11
P Series Quick Release Couplings - Thor Interchange	12-14
Air King Couplings	15-18
Air King Clamps	15-18
Crimp Ferrule	18
European Compressor Couplings	19
European Compressor Two Bolt Clamps.....	19
King Safety Cable Hose Restraint - 'Whipcheck Style'	20
Blow Guns	21

FOR A FULL RANGE OF AIR HOSES
TO COMPLEMENT THESE FITTINGS SEE SECTION F

A

Quick Release Couplings - N Series Bowes/MacDonald Interchange

- Dual-guide sleeve tabs will ensure smooth collar action during connection and disconnection
- Convenient 'Push-Twist and Click' connection provides a positive locking condition while connected
- Pneumatically energised seal provides an airtight seal at all working pressures
- Optional safety-lock ring protects against accidental disconnection while coupling is in operation
- Highly versatile selection of end connections and body materials, as well as an available valved coupler option



PERFORMANCE SPECIFICATIONS	OPERATING BAR (psi)	BURST BAR (psi)	FLOW ΔP=0.4 BAR (6.9 BAR INLET)	LOCKING MECHANISM
3/8"	21 (300)	207 (3,000)	84 CFM	Latch Tabs
1/2"	21 (300)	207 (3,000)	250 CFM	Latch Tabs
1 1/4"	21 (300)	103 (1,500)	700 CFM	Latch Tabs

INTERCHANGE STANDARDS	US MILITARY	US GOVERNMENT	INTERNATIONAL STANDARDS	ANSI/NFPA
1/2"	MIL-C-3486	A-A-50431A	-	-

'N' SERIES INTERCHANGE	BOWES	NATIONAL	MACDONALD	DIXON
3/8"	-	-	-	-
1/2"	51000 Series	Series 'B'	Quick-Action	Dixlock
1 1/4"	51000 Series	-	-	-



(Male Thread)

N-SERIES (MINI-BOWES) INTERCHANGE (COUPLER)			
PART NO.	BODY SIZE	THREAD SIZE	BODY MATERIAL
3NM4	3/8"	1/2"-14 NPTF	steel
3NBM4	3/8"	R1/2" BSPT	steel



(Male Thread)

N-SERIES (MINI-BOWES) INTERCHANGE (NIPPLE)			
PART NO.	BODY SIZE	THREAD SIZE	BODY MATERIAL
N3M4	3/8"	1/2"-14 NPTF	steel
N3BM4	3/8"	R1/2" BSPT	steel



(Collar Barb)

N-SERIES (MINI-BOWES) INTERCHANGE (COUPLER)			
PART NO.	BODY SIZE	BARB CONFIGURATION	BODY MATERIAL
3NCS4	3/8"	1/2" Collar Barb	steel



(Collar Barb)

N-SERIES (MINI-BOWES) INTERCHANGE (NIPPLE)

PART NO.	BODY SIZE	BARB CONFIGURATION	BODY MATERIAL
N3CS4	3/8"	1/2" Collar Barb	steel



(Female Thread)

N-SERIES MACDONALD INTERCHANGE (UNVALVED COUPLER)

PART NO.	BODY SIZE	THREAD SIZE	BODY MATERIAL
4NF3	1/2"	3/8"-18 NPTF	steel
4NF3-B	1/2"	3/8"-18 NPTF	brass
4NBF3	1/2"	G3/8" BSPP	steel
4NF4	1/2"	1/2"-14 NPTF	steel
4NF4-B	1/2"	1/2"-14 NPTF	brass
4NBF4	1/2"	G1/2" BSPP	steel
4NBF4-B	1/2"	G1/2" BSPP	brass
4NF6	1/2"	3/4"-14 NPTF	steel
4NF6-B	1/2"	3/4"-14 NPTF	brass
4NF6-S	1/2"	3/4"-14 NPTF	303 SS
4NBF6	1/2"	G3/4" BSPP	steel
4NBF6-B	1/2"	G3/4" BSPP	brass
4NF8	1/2"	1"-11 1/2 NPTF	steel
4NF8-B	1/2"	1"-11 1/2 NPTF	brass
4NBF8	1/2"	G1" BSPP	steel
4NBF8-B	1/2"	G1" BSPP	brass



(Female Thread)

N-SERIES MACDONALD INTERCHANGE (VALVED COUPLER)

PART NO.	BODY SIZE	THREAD SIZE	BODY MATERIAL
4NF6-V	1/2"	3/4"-14 NPTF	steel
4NBF6-V	1/2"	G3/4" BSPP	steel



(Female Thread)

N-SERIES MACDONALD INTERCHANGE (NIPPLE)

PART NO.	BODY SIZE	THREAD SIZE	BODY MATERIAL
N4F3	1/2"	3/8"-18 NPTF	steel
N4F3-B	1/2"	3/8"-18 NPTF	brass
N4BF3	1/2"	G3/8" BSPP	steel
N4F4	1/2"	1/2"-14 NPTF	steel
N4F4-B	1/2"	1/2"-14 NPTF	brass
N4BF4	1/2"	G1/2" BSPP	steel
N4BF4-B	1/2"	G1/2" BSPP	brass
N4F6	1/2"	3/4"-14 NPTF	steel
N4F6-B	1/2"	3/4"-14 NPTF	brass
N4F6-S	1/2"	3/4"-14 NPTF	303 SS
N4BF6	1/2"	G3/4" BSPP	steel
N4BF6-B	1/2"	G3/4" BSPP	brass
N4F8	1/2"	1"-11 1/2 NPTF	steel
N4F8-B	1/2"	1"-11 1/2 NPTF	brass
N4BF8	1/2"	G1" BSPP	steel
N4BF8-B	1/2"	G1" BSPP	brass



(Female Thread)

N-SERIES MACDONALD INTERCHANGE (SAFETY-LOCK NIPPLE)

PART NO.	BODY SIZE	THREAD SIZE	BODY MATERIAL
N4F4-B-LS	1/2"	1/2"-14 NPTF	brass
N4F6-B-LS	1/2"	3/4"-14 NPTF	brass

A



(Male Thread)

N-SERIES MACDONALD INTERCHANGE (UNVALVED COUPLER)

PART NO.	BODY SIZE	THREAD SIZE	BODY MATERIAL
4NM3	1/2"	3/8"-18 NPTF	steel
4NM3-B	1/2"	3/8"-18 NPTF	brass
4NBM3	1/2"	R3/8" BSPT	steel
4NM4	1/2"	1/2"-14 NPTF	steel
4NM4-B	1/2"	1/2"-14 NPTF	brass
4NBM4	1/2"	R1/2" BSPT	steel
4NBM4-B	1/2"	R1/2" BSPT	brass
4NM6	1/2"	3/4"-14 NPTF	steel
4NM6-B	1/2"	3/4"-14 NPTF	brass
4NM6-S	1/2"	3/4"-14 NPTF	303 SS
4NBM6	1/2"	R3/4" BSPT	steel
4NBM6-B	1/2"	R3/4" BSPT	brass
4NM8	1/2"	1"-11 1/2 NPTF	steel
4NM8-B	1/2"	1"-11 1/2 NPTF	brass
4NBM8	1/2"	R1" BSPT	steel
4NBM8-B	1/2"	R1" BSPT	brass



(Male Thread)

N-SERIES MACDONALD INTERCHANGE (VALVED COUPLER)

PART NO.	BODY SIZE	THREAD SIZE	BODY MATERIAL
4NM6-V	1/2"	3/4"-14 NPTF	steel



(Male Thread)

N-SERIES MACDONALD INTERCHANGE (NIPPLE)

PART NO.	BODY SIZE	THREAD SIZE	BODY MATERIAL
N4M3	1/2"	3/8"-18 NPTF	steel
N4M3-B	1/2"	3/8"-18 NPTF	brass
N4BM3	1/2"	R3/8" BSPT	steel
N4M4	1/2"	1/2"-14 NPTF	steel
N4M4-B	1/2"	1/2"-14 NPTF	brass
N4BM4	1/2"	R1/2" BSPT	steel
N4BM4-B	1/2"	R1/2" BSPT	brass
N4M6	1/2"	3/4"-14 NPTF	steel
N4M6-B	1/2"	3/4"-14 NPTF	brass
N4M6-S	1/2"	3/4"-14 NPTF	303 SS
N4BM6	1/2"	R3/4" BSPT	steel
N4BM6-B	1/2"	R3/4" BSPT	brass
N4M8	1/2"	1"-11 1/2 NPTF	steel
N4M8-B	1/2"	1"-11 1/2 NPTF	brass
N4BM8	1/2"	R1" BSPT	steel
N4BM8-B	1/2"	R1" BSPT	brass



(Male Thread)

N-SERIES MACDONALD INTERCHANGE (SAFETY-LOCK NIPPLE)

PART NO.	BODY SIZE	THREAD SIZE	BODY MATERIAL
N4M4-LS	1/2"	1/2"-14 NPTF	steel
N4M4-B-LS	1/2"	1/2"-14 NPTF	brass
N4BM4-LS	1/2"	R1/2" BSPT	steel
N4M6-LS	1/2"	3/4"-14 NPTF	steel
N4M6-B-LS	1/2"	3/4"-14 NPTF	brass
N4M6-S-LS	1/2"	3/4"-14 NPTF	303 SS
N4BM6-LS	1/2"	R3/4" BSPT	steel



(Hose Barb - now accepts light duty ferrules)

N-SERIES MACDONALD INTERCHANGE (COUPLER)			
PART NO.	BODY SIZE	BARB CONFIGURATION	BODY MATERIAL
4NS3	1/2"	3/8" Hose Barb	steel
4NS3-B	1/2"	3/8" Hose Barb	brass
4NS4	1/2"	1/2" Hose Barb	steel
4NS4-B	1/2"	1/2" Hose Barb	brass
4NS6	1/2"	3/4" Hose Barb	steel
4NS6-B	1/2"	3/4" Hose Barb	brass
4NS6-S	1/2"	3/4" Hose Barb	303 SS
4NS8	1/2"	1" Hose Barb	steel
4NS8-B	1/2"	1" Hose Barb	brass



(Hose Barb with Staked Ferrule)

N-SERIES MACDONALD INTERCHANGE (COUPLER)			
PART NO.	BODY SIZE	HOSE (ID) OD RANGE	BODY MATERIAL
4NCS4-WF43	1/2"	(1/2") 27/32" to 11/32"	steel
4NCS4-B-WF43	1/2"	(1/2") 27/32" to 11/32"	brass
4NCS6-WF63	1/2"	(3/4") 15/32" to 11/32"	steel
4NCS6-B-WF63	1/2"	(3/4") 15/32" to 11/32"	brass
4NCS6-S-WFS63	1/2"	(3/4") 15/32" to 11/32"	303 SS



(Hose Barb - now accepts light duty ferrules)

N-SERIES MACDONALD INTERCHANGE (NIPPLE)			
PART NO.	BODY SIZE	BARB CONFIGURATION	BODY MATERIAL
N4S3	1/2"	3/8" Hose Barb	steel
N4S3-B	1/2"	3/8" Hose Barb	brass
N4S4	1/2"	1/2" Hose Barb	steel
N4S4-B	1/2"	1/2" Hose Barb	brass
N4S6	1/2"	3/4" Hose Barb	steel
N4S6-B	1/2"	3/4" Hose Barb	brass
N4S6-S	1/2"	3/4" Hose Barb	303 SS
N4S8	1/2"	1" Hose Barb	steel
N4S8-B	1/2"	1" Hose Barb	brass



(Hose Barb with Staked Ferrule)

N-SERIES MACDONALD INTERCHANGE (NIPPLE)			
PART NO.	BODY SIZE	HOSE (ID) OD RANGE	BODY MATERIAL
N4CS4-WF43	1/2"	(1/2") 27/32" to 11/32"	steel
N4CS4-B-WF43	1/2"	(1/2") 27/32" to 11/32"	brass
N4CS6-WF63	1/2"	(3/4") 15/32" to 11/32"	steel
N4CS6-B-WF63	1/2"	(3/4") 15/32" to 11/32"	brass
N4CS6-S-WFS63	1/2"	(3/4") 15/32" to 11/32"	303 SS



(Hose Barb - now accepts light duty ferrules)

N-SERIES MACDONALD INTERCHANGE (SAFETY-LOCK NIPPLE)			
PART NO.	BODY SIZE	BARB CONFIGURATION	BODY MATERIAL
N4S4-LS	1/2"	1/2" Hose Barb	steel
N4S4-B-LS	1/2"	1/2" Hose Barb	brass
N4S6-LS	1/2"	3/4" Hose Barb	steel
N4S6-B-LS	1/2"	3/4" Hose Barb	brass
N4S6-S-LS	1/2"	3/4" Hose Barb	303 SS

A



(Hose Barb with Staked Ferrule)

N-SERIES MACDONALD INTERCHANGE (SAFETY-LOCK NIPPLE)

PART NO.	BODY SIZE	HOSE (ID) OD RANGE	BODY MATERIAL
N4CS4-LS-WF43	1/2"	(1/2") 27/32" to 11/32"	steel
N4CS4-B-LS-WF43	1/2"	(1/2") 27/32" to 11/32"	brass
N4CS6-LS-WF63	1/2"	(3/4") 15/32" to 11/32"	steel
N4CS6-B-LS-WF63	1/2"	(3/4") 15/32" to 11/32"	brass
N4CS6-S-LS-WFS63	1/2"	(3/4") 15/32" to 11/32"	303 SS



(Female Thread)

N-SERIES (MEGA-BOWES) INTERCHANGE (COUPLER)

PART NO.	BODY SIZE	THREAD SIZE	BODY MATERIAL
10NF8-B	1 1/4"	1"-1 1/2" NPTF	brass
10NF10-B	1 1/4"	1 1/4"-1 1/2" NPTF	brass



(Female Thread)

N-SERIES (MEGA-BOWES) INTERCHANGE (NIPPLE)

PART NO.	BODY SIZE	THREAD SIZE	BODY MATERIAL
N10F8-B	1 1/4"	1"-1 1/2" NPTF	brass
N10F10-B	1 1/4"	1 1/4"-1 1/2" NPTF	brass



(Male Thread)

N-SERIES (MEGA-BOWES) INTERCHANGE (COUPLER)

PART NO.	BODY SIZE	THREAD SIZE	BODY MATERIAL
10NM8-B	1 1/4"	1"-1 1/2" NPTF	brass
10NM10-B	1 1/4"	1 1/4"-1 1/2" NPTF	brass



(Male Thread)

N-SERIES (MEGA-BOWES) INTERCHANGE (NIPPLE)

PART NO.	BODY SIZE	THREAD SIZE	BODY MATERIAL
N10M8-B	1 1/4"	1"-1 1/2" NPTF	brass
N10M10-B	1 1/4"	1 1/4"-1 1/2" NPTF	brass

A Safety Check Valve, also known as an Excessive Flow Sensor should be installed at the source of supply to protect the operator in case of coupling failure or hose rupture.





N-SERIES MACDONALD INTERCHANGE (GENDER-CHANGE UNION)

PART NO.	BODY SIZE	PART DESCRIPTION	BODY MATERIAL
4N4N	1/2"	Coupler to Coupler	steel



N-SERIES MACDONALD INTERCHANGE (Y-COUPPLERS)

PART NO.	BODY SIZE	INLET/OUTLET CONFIGURATION	BODY MATERIAL
N4Y4N-4N	1/2"	Nipple to Couplers	steel



N-SERIES MACDONALD INTERCHANGE (Y-NIPPLES)

PART NO.	BODY SIZE	INLET/OUTLET CONFIGURATION	BODY MATERIAL
4NYN4-N4	1/2"	Nipple to Couplers	steel



N-SERIES MACDONALD INTERCHANGE (PROTECTIVE NIPPLE CAP)

PART NO.	BODY SIZE	PART DESCRIPTION	BODY MATERIAL
N4DC	1/2"	Nipple Dust Cap	steel
N4DC-B	1/2"	Nipple Dust Cap	brass



N-SERIES MACDONALD INTERCHANGE (REPLACEMENT PARTS)

PART NO.	BODY SIZE	PART DESCRIPTION	PART MATERIAL
3N-SKIT	3/8"	Sealing Gasket	Nitrile
4N-SKIT	1/2"	Sealing Gasket	Nitrile
10N-SKIT	1 1/4"	Sealing Gasket	Nitrile

Quick Release Couplings - P-Series Thor Interchange

A

- Interlocking finger connection method with single or dual locking sleeves for maximum security
- Convenient 'Push-Twist and Click' connection provides a positive locking condition while connected
- Corrosion resistant steel construction and a variety of other materials available to provide additional corrosion resistance
- Optional safety-lock clip protects against accidental disconnection while coupling is in operation
- Highly versatile selection of end connections includes Female NPTF, Male NPTF and Hose barb



PERFORMANCE SPECIFICATIONS	OPERATING BAR (psi)	BURST BAR (psi)	FLOW ΔP=0.4 BAR (6.9 BAR INLET)	LOCKING MECHANISM
1/2"	21 (300)	331 (4,800)	250 CFM	Latch Fingers

'P' SERIES INTERCHANGE	THOR	NATIONAL	DIXON	
1/2"	PHC	Series 'A'	Dual-Lock	-



(Female Thread)

P-SERIES THOR INTERCHANGE (COUPLER)

PART NO.	BODY SIZE	THREAD SIZE	BODY MATERIAL
4PF4	1/2"	1/2"-14 NPTF	steel
4PF6	1/2"	3/4"-14 NPTF	steel
4PF6-B	1/2"	3/4"-14 NPTF	brass
4PF6-S	1/2"	3/4"-14 NPTF	303 SS



(Female Thread)

P-SERIES THOR INTERCHANGE (FLANGED-SLEEVE COUPLER)

PART NO.	BODY SIZE	THREAD SIZE	BODY MATERIAL
4PF4-FS	1/2"	1/2"-14 NPTF	steel
4PF6-FS	1/2"	3/4"-14 NPTF	steel



(Female Thread)

P-SERIES THOR INTERCHANGE (NIPPLE)

PART NO.	BODY SIZE	THREAD SIZE	BODY MATERIAL
P4F3	1/2"	3/8"-18 NPTF	steel
P4F4	1/2"	1/2"-14 NPTF	steel
P4F4-B	1/2"	1/2"-14 NPTF	brass
P4F6	1/2"	3/4"-14 NPTF	steel
P4F6-B	1/2"	3/4"-14 NPTF	brass
P4F6-S	1/2"	3/4"-14 NPTF	303 SS
P4F8	1/2"	1"-11 1/2 NPTF	steel
P4F8-B	1/2"	1"-11 1/2 NPTF	brass



(Male Thread)

P-SERIES THOR INTERCHANGE (COUPLER)			
PART NO.	BODY SIZE	THREAD SIZE	BODY MATERIAL
4PM3	1/2"	3/8"-18 NPTF	steel
4PM4	1/2"	1/2"-14 NPTF	steel
4PM6	1/2"	3/4"-14 NPTF	steel
4PM6-S	1/2"	3/4"-14 NPTF	303 SS



(Male Thread)

P-SERIES THOR INTERCHANGE (FLANGED-SLEEVE COUPLER)			
PART NO.	BODY SIZE	THREAD SIZE	PART MATERIAL
4PM3-FS	1/2"	3/8"-18 NPTF	steel
4PM4-FS	1/2"	1/2"-14 NPTF	steel
4PM6-FS	1/2"	3/4"-14 NPTF	steel



(Male Thread)

P-SERIES THOR INTERCHANGE (NIPPLE)			
PART NO.	BODY SIZE	THREAD SIZE	BODY MATERIAL
P4M3	1/2"	3/8"-18 NPTF	steel
P4M4	1/2"	1/2"-14 NPTF	steel
P4M4-B	1/2"	1/2"-14 NPTF	brass
P4M6	1/2"	3/4"-14 NPTF	steel
P4M6-B	1/2"	3/4"-14 NPTF	brass
P4M6-S	1/2"	3/4"-14 NPTF	303 SS
P4M8	1/2"	1"-11 1/2 NPTF	steel
P4M8-B	1/2"	1"-11 1/2 NPTF	brass



(Hose Barb - now accepts light duty ferrules)

P-SERIES THOR INTERCHANGE (COUPLER)			
PART NO.	BODY SIZE	BARB CONFIGURATION	BODY MATERIAL
4PS3	1/2"	3/8" Hose Barb	steel
4PS4	1/2"	1/2" Hose Barb	steel
4PS4-B	1/2"	1/2" Hose Barb	brass
4PS6	1/2"	3/4" Hose Barb	steel
4PS6-B	1/2"	3/4" Hose Barb	brass
4PS6-S	1/2"	3/4" Hose Barb	303 SS
4PS8	1/2"	1" Hose Barb	steel
4PS8-B	1/2"	1" Hose Barb	brass

A



(Hose Barb - now accepts light duty ferrules)

P-SERIES THOR INTERCHANGE (FLANGED-SLEEVE COUPLER)

PART NO.	BODY SIZE	BARB CONFIGURATION	BODY MATERIAL
4PS3-FS	1/2"	3/8" Hose Barb	steel
4PS4-FS	1/2"	1/2" Hose Barb	steel
4PS6-FS	1/2"	3/4" Hose Barb	steel
4PS8-FS	1/2"	1" Hose Barb	steel



(Hose Barb with Staked Ferrule)

P-SERIES THOR INTERCHANGE (COUPLER)

PART NO.	BODY SIZE	HOSE (ID) OD RANGE	BODY MATERIAL
4PCS4-WF43	1/2"	(1/2") 27/32" to 11/32"	steel
4PCS4-B-WF43	1/2"	(1/2") 27/32" to 11/32"	brass
4PCS6-WF63	1/2"	(3/4") 15/32" to 11/32"	steel
4PCS6-B-WF63	1/2"	(3/4") 15/32" to 11/32"	brass



(Hose Barb with Staked Ferrule)

P-SERIES THOR INTERCHANGE (FLANGED-SLEEVE COUPLER)

PART NO.	BODY SIZE	HOSE (ID) OD RANGE	BODY MATERIAL
4PCS4-FS-WF43	1/2"	(1/2") 27/32" to 11/32"	steel
4PCS6-FS-WF63	1/2"	(3/4") 15/32" to 11/32"	steel



P-SERIES THOR INTERCHANGE (REPLACEMENT PARTS)

PART NO.	BODY SIZE	PART DESCRIPTION	BODY MATERIAL
4P-SKIT	1/2"	Seal Gasket	Nitrile
4P-CLIP	1/2"	Sleeve-Lock Clip	steel
4P-CLIPS	1/2"	Spring Clip	steel

Air King Universal Couplings

AIR HOSE COUPLINGS – This form of energy can be one of the most dangerous because it is used in so many applications and when mishandled, can have more serious results than fluids. Air, as a gas, is compressible (fluids press only against hose or vessel walls and lose little volume under pressure). When pressurised air releases suddenly, it does so with explosive force and can cause rapid hose whip, which can do serious physical harm to personnel or damage to nearby objects. This is why the selection of proper hose and couplings for air-lines is so important, along with their proper installation and maintenance. Never take for granted that a coupling is installed properly or a clamp fully tightened on an air hose – check it regularly and use safety devices (see King Cable Hose Restraint Section).

Air King universal couplings can be recommended for 10 bar (150psi) working pressure at ambient temperature (21°C / 70°F). It is recommended that an Air King safety clip or wire restrainer is used to avoid accidental disconnection. Also a King cable should be standard practice on the supply end of the hose. Boss or Air King interlocking type bolt clamps should be used and both components of an Air King assembly should be Dixon products standard Air King fittings are fitted with AWR4 washers. Air King is also available to meet MIL spec. WWC-633D.

4-lug King quick-acting couplings may only be used in conjunction with an Air King Safety Clip.

Note: Air King is for Air and Water service only. NEVER use any “AIR KING” for STEAM SERVICE.



MALE NPT END		
PART NO.	SIZE	MATERIAL
AMB1	1/4"	Malleable Iron
AMB	3/8"	Malleable Iron
AM2	1/2"	Investment Cast Carbon Steel
AM7	3/4"	Investment Cast Carbon Steel
AM12	1"	Investment Cast Carbon Steel
ABB1	1/4"	Brass
ABB	3/8"	Brass
AB2	1/2"	Brass
AB7	3/4"	Brass
AB12	1"	Brass
RAM2	1/2"	316 Stainless Steel
RAM7	3/4"	316 Stainless Steel
RAM12	1"	316 Stainless Steel



FEMALE NPT END		
PART NO.	SIZE	MATERIAL
AMC1	1/4"	Malleable Iron
AMC	3/8"	Malleable Iron
AM3	1/2"	Investment Cast Carbon Steel
AM8	3/4"	Investment Cast Carbon Steel
AM13	1"	Investment Cast Carbon Steel
ABC1	1/4"	Brass
ABC	3/8"	Brass
AB3	1/2"	Brass
AB8	3/4"	Brass
AB13	1"	Brass
RAM3	1/2"	316 Stainless Steel
RAM8	3/4"	316 Stainless Steel
RAM13	1"	316 Stainless Steel

A



"AIR KING" BLANK CAP

PART NO.	MATERIAL
AM0	Investment Cast Carbon Steel
AB0	Brass
RAM0	316 Stainless Steel



"AIR KING" TRIPLE CONNECTOR

PART NO.	MATERIAL
AM10	Investment Cast Carbon Steel
AB10	Brass



"AIR KING" UNIVERSAL SWIVELS

PART NO.	SIZE
AM2SWIV	1/2" Male NPT
AM6SWIV	3/4" Hose End
AM7SWIV	3/4" Male NPT
AM8SWIV	3/4" Female NPT



SAFETY CLIPS

PART NO.	DESCRIPTION
AC1	SAFETY CLIPS (In bags of 25) Same size for all coupling sizes



SAFETY CLIPS

PART NO.	DESCRIPTION
AC7	STAINLESS STEEL CLIPS Same size for all coupling sizes



LANYARDS	
PART NO.	DESCRIPTION
LR7 ACL8	Stainless Steel Synthetic Cord (In bags of 25) Same size for all coupling sizes



"AIR KING" CLAMPS			
PART NO.	SIZE	OD. RANGE	TORQUE (FT.LBS)
CD	3/8"	17.5 - 22.2	6
A4	1/2"	25.4 - 30.1	6
A9	3/4"	28.6 - 33.3	21
A10*	1"	33.3 - 38.1	21
A14	1"	38.1 - 46.4	21

Torque values for clamps are based on "Dry Bolts". The use of lubricant on bolts will adversely effect clamp performance. *Can be used with AM6 and AM11 Couplings.



"AIR KING" WITH FERRULES			
PART NO.	SIZE	OD. RANGE	MATERIAL
AM1WF	1/2"	21.4 - 23.0	Malleable Iron
AM6WF	3/4"	26.9 - 34.1	Malleable Iron
AM11WF-1	1"	32.5 - 38.8	Malleable Iron
AM11WF	1"	37.3 - 43.6	Malleable Iron
RAM6WF	3/4"	26.9 - 34.1	Stainless Steel



"KING" 4 LUG QUICK-ACTING HOSE END COUPLINGS		
PART NO.	SIZE	MATERIAL
AM16	1 1/4"	Malleable Iron
AM21	1 1/2"	Malleable Iron
AM26	2"	Malleable Iron
AB16	1 1/4"	Brass
AB21	1 1/2"	Brass
AB26	2"	Brass

Must be used in conjunction with an "Air King" safety clip.



"KING" QUICK-ACTING FEMALE NPT END COUPLINGS		
PART NO.	SIZE	MATERIAL
AM18	1 1/4"	Malleable Iron
AM23	1 1/2"	Malleable Iron
AM28	2"	Malleable Iron
AB18	1 1/4"	Brass
AB23	1 1/2"	Brass
AB28	2"	Brass

A



WASHERS FOR 4-LUG

PART NO.
AWR 14 Fits all sizes

WASHERS FOR 2-LUG

PART NO.	DESCRIPTION
AWR4* AWS6*	Black Natural Rubber Neoprene

*Sold only in bags of 50.



HOSE END

PART NO.	SIZE	MATERIAL
AMH	3/8"	Malleable Iron
AM1*	1/2"	Investment Cast Carbon Steel
AM5	5/8"	Malleable Iron
AM6*	3/4"	Investment Cast Carbon Steel
AM11*	1"	Investment Cast Carbon Steel
ABH	3/8"	Brass
AB1*	1/2"	Brass
AB5	5/8"	Brass
AB6*	3/4"	Brass
AB11*	1"	Brass
RAM1	1/2"	316 Stainless Steel
RAM6	3/4"	316 Stainless Steel
RAM11	1"	316 Stainless Steel

*These hose ends can now be crimped using the ferrules below.



CRIMP FERRULES

PART NO.	SIZE	HOSE OD (INCH)	MATERIAL
CCF0906	1/2"	0.8438	Carbon Steel
CCF0906	1/2"	0.8594	Carbon Steel
CCF0906	1/2"	0.8750	Carbon Steel
CCF1120	3/4"	1.0781	Carbon Steel
CCF1120	3/4"	1.0938	Carbon Steel
CCF1149	3/4"	1.1094	Carbon Steel
CCF1149	3/4"	1.1250	Carbon Steel
CCF1190	3/4"	1.1406	Carbon Steel
CCF1190	3/4"	1.1563	Carbon Steel
CCF1218	3/4"	1.1719	Carbon Steel
CCF1218	3/4"	1.1875	Carbon Steel
CCF1246	3/4"	1.2031	Carbon Steel
CCF1246	3/4"	1.2188	Carbon Steel
CCF1438	1"	1.3906	Carbon Steel
CCF1438	1"	1.4063	Carbon Steel
CCF1469	1"	1.4219	Carbon Steel
CCF1469	1"	1.4375	Carbon Steel
CCF1500	1"	1.4531	Carbon Steel
CCF1500	1"	1.4688	Carbon Steel
CCF1531	1"	1.4844	Carbon Steel
CCF1531	1"	1.5000	Carbon Steel

European Compressor Couplings and Clamps

Sizes:	3/8" to 1" (DN10 to DN25)						
Material:	Ductile Iron, Malleable Iron, Investment Cast Carbon Steel. Gold Chromate Plated						
Couplings:	Generally designed to interchange with DIN 3489:2001 couplings						
Clamps:	Generally designed to interchange with DIN 20039:1998 clamp						
Pressure:	<table border="0"> <tr> <td>Couplings:</td> <td>Maximum working pressure 150psi/10 Bar</td> </tr> <tr> <td>Claw Clamps:</td> <td>Maximum working pressure 360psi/25 Bar</td> </tr> <tr> <td>Non-Claw Clamp:</td> <td>Maximum working pressure 232psi/16 Bar</td> </tr> </table>	Couplings:	Maximum working pressure 150psi/10 Bar	Claw Clamps:	Maximum working pressure 360psi/25 Bar	Non-Claw Clamp:	Maximum working pressure 232psi/16 Bar
Couplings:	Maximum working pressure 150psi/10 Bar						
Claw Clamps:	Maximum working pressure 360psi/25 Bar						
Non-Claw Clamp:	Maximum working pressure 232psi/16 Bar						
Threads:	BSP PI. / BSPT in accordance with ISO 228						



MALE ADAPTER	
PART NO.	SIZE
QDM38M	3/8"
QDM50M	1/2"
QDM75M	3/4"
QDM100M	1"



FEMALE ADAPTER	
PART NO.	SIZE
QDF38M	3/8"
QDF50M	1/2"
QDF75M	3/4"
QDF100M	1"



HOSE END	
PART NO.	SIZE
QDHE38M	3/8" (No Collar)
QDHE50M	1/2" (No Collar)
QDHE75M	3/4" (With Collar)
QDHE100M	1" (No Collar)



WASHERS FOR 2-LUG	
PART NO.	DESCRIPTION
EAWR4*	Black Natural Rubber
AWS6*	Neoprene

Temperature Range:
-29°C (-20°F)
to 71°C (160°F).

*Sold only in bags of 50.



SERIES TSC - TWO-BOLT SADDLE CLAMPS (MALLEABLE IRON)		
PART NO.	SIZES	HOSE O.D. RANGE (mm)
TSC25	5/8" - 15/16"	17 - 22
TSC31	15/16" - 11/8"	22 - 29
TSC34	11/16" - 11/4"	27 - 32
TSC37	11/4" - 17/16"	32 - 37
TSC1305	11/2" - 115/16"	39 - 49
TSC1306	129/32" - 23/8"	48 - 60
TSC1307	23/8" - 31/64"	60 - 76
TSC1308	31/32" - 311/16"	77 - 94
TSC1309	311/16" - 41/2"	94 - 115
		WITH SAFETY CLAWS
TSK34	11/8" - 11/4" (Investment Cast Steel)	28 - 32

King Safety Cable Hose Restraint

A

When hose, couplings or clamps fail, or there is an accidental separation of the assembly, Dixon King Cable Hose Restraints minimise damage to equipment and injuries to personnel. Dixon King Cable Hose Restraints reaches across the hose fittings to provide standby safety for hose.

Spring-loaded loops in the cable ends open easily to pass over the couplings for a firm grip on the hose. Thoroughly tested with years of service. A positive safeguard for air hose connections – helps you to meet today's safety standards

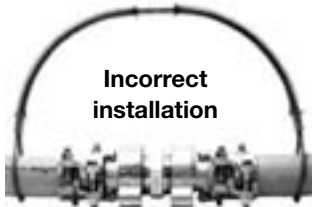

Incorrect installation



Correct Installation

Features:

- hose-to-hose or hose-to-rigid outlet
- King cable is the low cost answer to eliminate injuries caused by broken air
- hose connections
- highly resistant to rust and corrosion
- no tools needed - easy to install and remove
- maximum working pressure: 200 PSI



STYLE W, FOR HOSE-TO-HOSE SERVICE

STEEL PART NO.	STAINLESS STEEL PART NO.	HOSE ID	CABLE DIAMETER	LENGTH	MAX WORKING PRESSURE
WB1	WB1SS	1/2" - 1 1/4"	1/8"	20 1/4"	200
WB3	N/A	1/2" - 2"	3/16"	28"	200
WA2	WB2SS	1 1/2" - 3"	1/4"	38 1/4"	200
WA4	N/A	4"	3/8"	44"	200



STYLE W, FOR HOSE-TO-TOOL SERVICE

STEEL PART NO.	STAINLESS STEEL PART NO.	HOSE ID	CABLE DIAMETER	LENGTH	MAX WORKING PRESSURE
WSR1	WSR1SS	1/2" - 1 1/4"	1/8"	20 1/4"	200
WSR3	N/A	1/2" - 2"	3/16"	28"	200
WSR2	WSR2SS	1 1/2" - 3"	1/4"	38 1/4"	200
WSR4	N/A	4"	3/8"	44"	200



KING SAFETY CABLE OPTIONS

PART NO.	CABLE DIAMETER	DESCRIPTION	MAX WORKING PRESSURE
WSR1C	1/8"	WSR1 with safety clip & lanyard used to lock Air King couplings.	200
WB1C	1/8"	WB1 with safety clip & lanyard used to lock Air King Couplings.	200
WSR1E	1/8"	WSR1 with Stainless steel safety marine eye used to connect safety cable to a bolt on tool.	200
WA2B	1/4"	WA2 with bronze/copper ferrule for special environmental conditions.e.g.mining/offshore.	200

Dixon King Cable Hose Restraints must be installed in the extended position. (No Slack)

Blow Guns



"AIR CHIEF" SAFETY BLOW GUN	
PART NO.	SIZE
D204-30	1/4" Female NPT Inlet

"Air Chief" Safety Gun - A basic safety blow gun for general purpose use. Tip pressure will not exceed 30 psi/2 bar, yet gives a good blast of air for cleaning. The gun has a safety tip which prevents build-up of tip pressure in the event of the outlet being obstructed or "dead ended". It complies with the requirements of OSHA 1910.242lb and 1910.95 when used on airlines of 150 psi, or less.



BLOW GUN EXTENSION	
PART NO.	SIZE EXTENSION
BGE6	6"
BGE10	10"
BGE12	12"

5/16" tip facilitates use in tight places. Blow gun tip thread is 1/8" NPT.



BLOW GUN	
PART NO.	SIZE
D201	1/4" Female NPT Inlet

Rubber Tipped Blowgun - Provides leakproof seal between gun and fluid line or other opening. Also excellent for cleaning moulds or delicate surfaces where a metal tip might scratch or otherwise harm critical areas.

CAUTION - This blow gun does not have a safety by-pass to prevent build-up of tip pressure in the event of tip blockage. It may be used for cleaning purposes only if the air supply (inlet pressure) has been reduced to 30 psi or less.



PISTOL GRIP BLOWGUN	
PART NO.	SIZE
PG700	1/4" Female NPT Inlet

- Contoured pistol-grip for safe, comfortable handling, even with greasy hands
- Convenient "hang-up" hook
- Complies with the U.S. Dept. of Labour, OSHA Standard 1910.242(B), permitting maximum 30 psi/2 bar outlet pressure at nozzle and Standard 1910.95 regulating occupational noise level exposure
- Conforms to Title 41, Walsh-Healy Rules and Regulations P50-204.8, Safety and Health standards

B

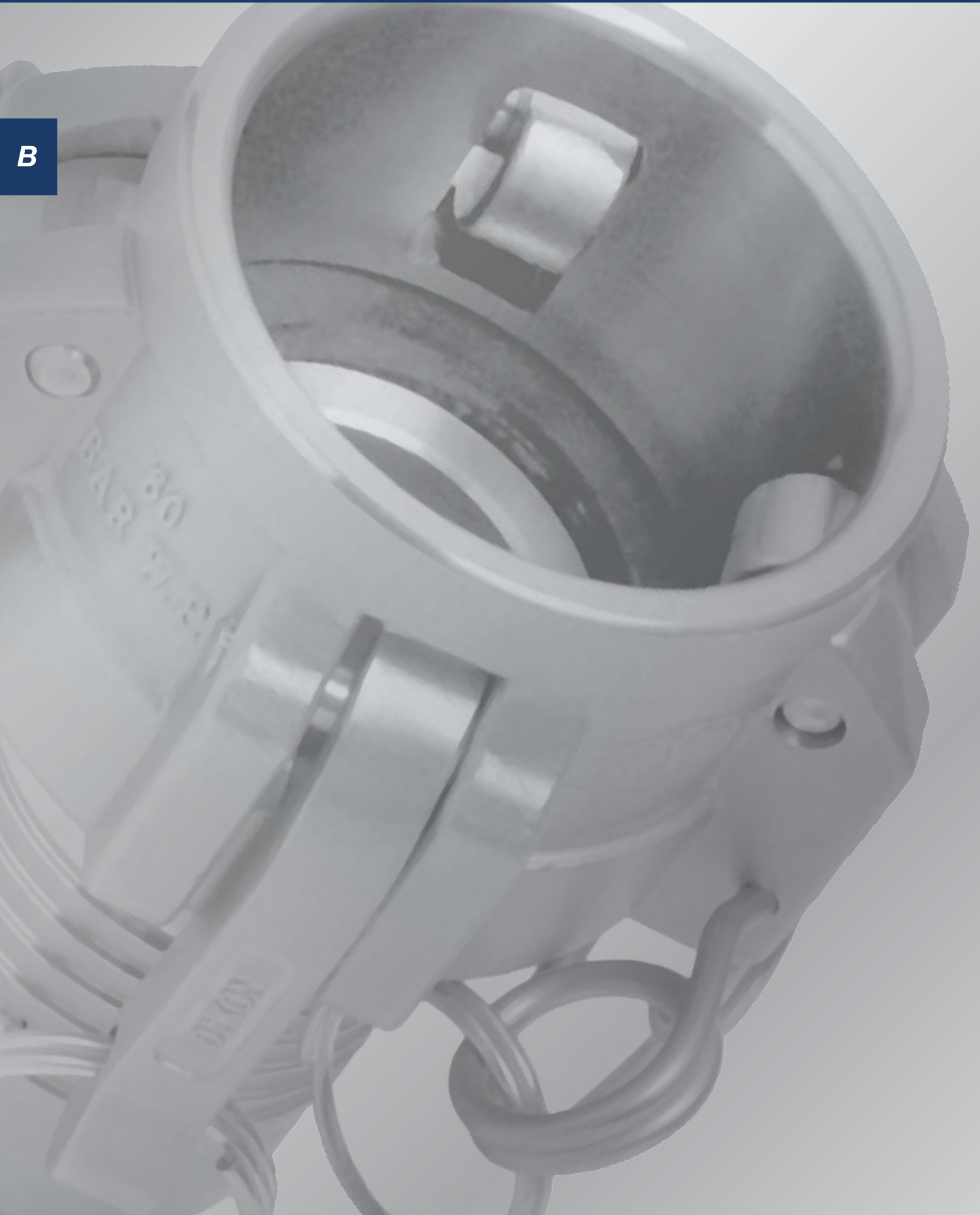

Cam & Groove

B

Cam & Groove Line Drawings	24-25
Dixon Cam & Groove "MIL-C-27487" / A-A-59326B Specification..	26-45
- Type A	26
- Type B	27-28
- Type C	29-30
- Type D	31-32
- Type E	33-34
- Type F	35
- Dust Plug	36
- Dust Cap	37-39
- Adapters & Accessories	39-45
King Crimp Style	46-48
DIN Specification BS EN14420 -7:2004	49
High Pressure Couplings & Adapters	50-52
Dry Mates	53
Seals & Gaskets	54-56

**FOR A FULL RANGE OF INDUSTRIAL HOSES
TO COMPLEMENT THESE FITTINGS SEE SECTION F**



Cam & Groove Type Line Drawings

B

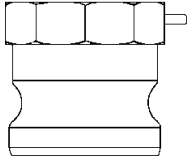

Type A

(male adapter x female NPT)

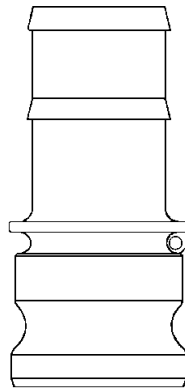

Type E

(male adapter x hose shank)

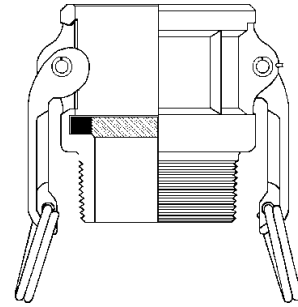

Type B

(female adapter x male NPT)

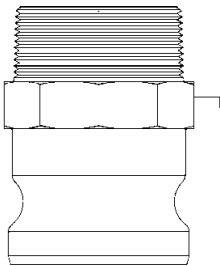

Type F

(male adapter x male NPT)

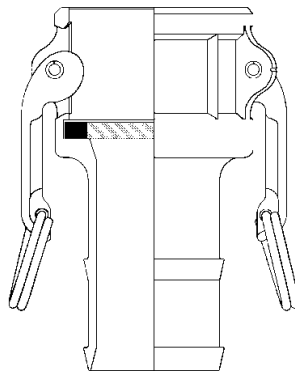

Type C

(female coupler x hose shank)

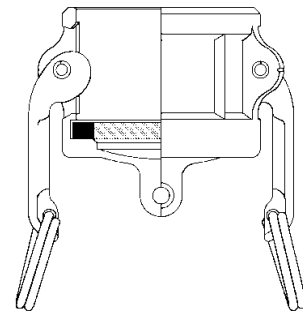

Type DC*

(dust cap)

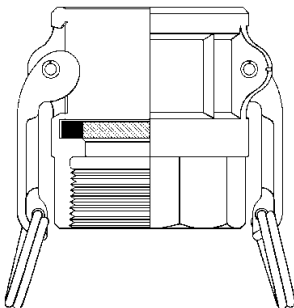

Type D

(female coupler x female NPT)

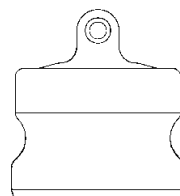

Type DP*

(dust plug)

Note: Line drawings are representative of the Dixon line of cam and groove.

* Dust caps and dust plugs are not to be used in pressure applications for safety and environmental reasons.

WARNING:
Under no circumstances should cam and groove couplings be used for compressed air or steam service!

All “Dixon”, “Andrews”, “Boss-Lock” and “EZ Boss-Lock” Cam & Groove couplers and adapters are produced to interchange with all product produced to A-A-59326B.

No standard exists for 1/2”, 5” and 8” fittings, and generally these sizes do not interchange with other manufacturers.

“Andrews” and “Boss-Lock” Cam and Groove Couplings do not interchange in the 8” size. (8” “Andrews” design has 4 cam arms).

DIN Standard Cam & Groove Couplers are produced in accordance with BS EN 14420-7:2004 (formally DIN2828).

Dixon High Pressure couplings will interchange dimensionally with both A-A-59326B and BS EN 14420-7:2004. Couplings for Rubber Hose are available to special order.

Dust Caps and Dust Plugs are **NOT** to be used in pressure applications for safety and environmental reasons.

Threads:

Male threads are either BSPT in accordance with BS21/DIN 2999 or NPT in accordance with ANSI/ASME B1.20.1

Female threads are either BSP PL. in accordance with BS2779/DIN ISO 228 or NPT in accordance with ANSI/ASME B1.20.1

PRESSURE RATINGS FOR A-A-59326B COUPLINGS							
SIZE	0.5in DN15	0.75in-2in DN20-DN50	2.5in DN65	3in DN80	4in DN100	5in and 6in DN125-DN150	8in DN200
A-A-59326B BSEN14420	150 psi	250 psi 10 Bar	150 psi 10 Bar	125 psi 10 Bar	100 psi 10 Bar	75 psi	50 psi

Pressure Ratings for Dixon High Pressure Cam & Groove Couplings – 60 Bar all sizes with the exception of 2.5” x 2” Coupler (HPCG65BSPF) which is 100 bar/1450 psi.

Pressure Ratings for Polypropylene Cam & Groove – 100 psi/7 Bar.

Note: All pressure recommendations are based on mating couplings at ambient temperature 21°C (70°F).

Types:

Andrews / Dixon



Boss Lock



EZ Boss Lock







Standard Cam & Groove A-A-59326B

B



DIXON CAM & GROOVE TYPE A ADAPTER x NPT THREADS A-A-59326B			
BSP PL. PART NO.	NPT PART NO.	SIZE	MATERIAL
50AALB	50AALN	1/2"	Aluminium
7550AALB	7550AALN	3/4" x 1/2"	Aluminium
75AALB	75AALN	3/4"	Aluminium
100AALB	100AALN	1"	Aluminium
125AALB	125AALN	1 1/4"	Aluminium
150AALB	150AALN	1 1/2"	Aluminium
200AALB	200AALN	2"	Aluminium
250AALB	250AALN	2 1/2"	Aluminium
300AALB	300AALN	3"	Aluminium
400AALB	400AALN	4"	Aluminium
500AALB	500AALN	5"	Aluminium
600AALB	600AALN	6"	Aluminium
800AALB	800AALN	8"	Aluminium
DAL50 AB	DAL50 AN	1/2"	Die Cast Aluminium
DAL7550 AB	DAL7550 AN	3/4" x 1/2"	Die Cast Aluminium
DAL75 AB	DAL75 AN	3/4"	Die Cast Aluminium
DAL100 AB	DAL100 AN	1"	Die Cast Aluminium
DAL125 AB	DAL125 AN	1 1/4"	Die Cast Aluminium
DAL150 AB	DAL150 AN	1 1/2"	Die Cast Aluminium
DAL200 AB	DAL200 AN	2"	Die Cast Aluminium
DAL250 AB	DAL250 AN	2 1/2"	Die Cast Aluminium
DAL300 AB	DAL300 AN	3"	Die Cast Aluminium
DAL400 AB	DAL400 AN	4"	Die Cast Aluminium
50ABRB	50ABRN	1/2"	Brass
7550ABRB	7550ABRN	3/4" x 1/2"	Brass
75ABRB	75ABRN	3/4"	Brass
100ABRB	100ABRN	1"	Brass
125ABRB	125ABRN	1 1/4"	Brass
150ABRB	150ABRN	1 1/2"	Brass
200ABRB	200ABRN	2"	Brass
250ABRB	250ABRN	2 1/2"	Brass
300ABRB	300ABRN	3"	Brass
400ABRB	400ABRN	4"	Brass
500ABRB	500ABRN	5"	Brass
600ABRB	600ABRN	6"	Brass
50ASSB	50ASSN	1/2"	Stainless Steel
7550ASSB	7550ASSN	3/4" x 1/2"	Stainless Steel
75ASSB	75ASSN	3/4"	Stainless Steel
100ASSB	100ASSN	1"	Stainless Steel
125ASSB	125ASSN	1 1/4"	Stainless Steel
150ASSB	150ASSN	1 1/2"	Stainless Steel
200ASSB	200ASSN	2"	Stainless Steel
250ASSB	250ASSN	2 1/2"	Stainless Steel
300ASSB	300ASSN	3"	Stainless Steel
400ASSB	400ASSN	4"	Stainless Steel
500ASSB	500ASSN	5"	Stainless Steel
600ASSB	600ASSN	6"	Stainless Steel
7550APPB	7550APPN	3/4" x 1/2"	Polypropylene
75APPB	75APPN	3/4"	Polypropylene
100APPB	100APPN	1"	Polypropylene
125APPB	125APPN	1 1/2" x 1 1/4"	Polypropylene
150APPB	150APPN	1 1/2"	Polypropylene
200APPB	200APPN	2"	Polypropylene
300APPB	300APPN	3"	Polypropylene
400APPB	400APPN	4"	Polypropylene

DIXON CAM & GROOVE TYPE B COUPLER x BSPT & NPT THREADS A-A-59326B

BSPT PART NO.	NPT PART NO.	SIZE	MATERIAL	
	50BALB	1/2"	Aluminium	
75BALB	75BALN	3/4"	Aluminium	
100BALB	100BALN	1"	Aluminium	
125BALB	125BALN	1 1/4"	Aluminium	
150BALB	150BALN	1 1/2"	Aluminium	
200BALB	200BALN	2"	Aluminium	
250BALB	250BALN	2 1/2"	Aluminium	
300BALB	300BALN	3"	Aluminium	
400BALB	400BALN	4"	Aluminium	
500BALB	500BALN	5"	Aluminium	
600BALB	600BALN	6"	Aluminium	
	DAL50 BB	DAL50 BN	1/2"	Die Cast Aluminium
DAL75 BB	DAL75 BN	3/4"	Die Cast Aluminium	
DAL100 BB	DAL100 BN	1"	Die Cast Aluminium	
DAL125 BB	DAL125 BN	1 1/4"	Die Cast Aluminium	
DAL150 BB	DAL150 BN	1 1/2"	Die Cast Aluminium	
DAL200 BB	DAL200 BN	2"	Die Cast Aluminium	
DAL250 BB	DAL250 BN	2 1/2"	Die Cast Aluminium	
DAL300 BB	DAL300 BN	3"	Die Cast Aluminium	
DAL400 BB	DAL400 BN	4"	Die Cast Aluminium	
	50BBRB	50BBRN	1/2"	Brass
75BBRB	75BBRN	3/4"	Brass	
100BBRB	100BBRN	1"	Brass	
125BBRB	125BBRN	1 1/4"	Brass	
150BBRB	150BBRN	1 1/2"	Brass	
200BBRB	200BBRN	2"	Brass	
250BBRB	250BBRN	2 1/2"	Brass	
300BBRB	300BBRN	3"	Brass	
400BBRB	400BBRN	4"	Brass	
500BBRB	500BBRN	5"	Brass	
600BBRB	600BBRN	6"	Brass	
	50BSSB	50BSSN	1/2"	Stainless Steel
75BSSB	75BSSN	3/4"	Stainless Steel	
100BSSB	100BSSN	1"	Stainless Steel	
125BSSB	125BSSN	1 1/4"	Stainless Steel	
150BSSB	150BSSN	1 1/2"	Stainless Steel	
200BSSB	200BSSN	2"	Stainless Steel	
250BSSB	250BSSN	2 1/2"	Stainless Steel	
300BSSB	300BSSN	3"	Stainless Steel	
400BSSB	400BSSN	4"	Stainless Steel	
500BSSB	500BSSN	5"	Stainless Steel	
600BSSB	600BSSN	6"	Stainless Steel	
	75BPPB	75BPPN	3/4"	Polypropylene
100BPPB	100BPPN	1"	Polypropylene	
125BPPB	125BPPN	1 1/2" x 1 1/4"	Polypropylene	
150BPPB	150BPPN	1 1/2"	Polypropylene	
200BPPB	200BPPN	2"	Polypropylene	
300BPPB	300BPPN	3"	Polypropylene	

"ANDREWS" TYPE B - 'REDUCING FEMALE COUPLER x MALE THREAD'



PART NO.	SIZE	MATERIAL	THREAD AVAILABLE
1510-B-AL	1 1/2" x 1"	Aluminium	NPT
2015-B-AL	2" x 1 1/2"	Aluminium	NPT
3020-B-AL	3" x 2"	Aluminium	NPT
3040-B-AL	3" x 4"	Aluminium	NPT
4030-B-AL	4" x 3"	Aluminium	NPT

Also available in Stainless Steel upon request

B



“BOSS-LOCK” TYPE B - ‘FEMALE COUPLER x MALE THREAD’

PART NO.	SIZE	THREAD AVAILABLE	MATERIAL
AB050	3/4" x 1/2"	NPT	Aluminium
AB075	3/4"	NPT	Aluminium
AB100	1"	NPT	Aluminium
AB125	1 1/4"	NPT	Aluminium
AB150	1 1/2"	NPT	Aluminium
AB200	2"	NPT	Aluminium
AB250	2 1/2"***	NPT	Aluminium
AB300	3"	NPT	Aluminium
AB400	4"	NPT	Aluminium
AB600	6"	NPT	Aluminium
BB050	3/4" x 1/2"	NPT	Brass
BB075	3/4"	NPT	Brass
BB100	1"	NPT	Brass
BB125	1 1/4"	NPT	Brass
BB150	1 1/2"	NPT	Brass
BB200	2"	NPT	Brass
BB250	2 1/2"***	NPT	Brass
BB300	3"	NPT	Brass
BB400	4"	NPT	Brass
BB600	6"	NPT	Brass
RB050BL	3/4" x 1/2"	NPT	Stainless Steel
RB075BL	3/4"	NPT	Stainless Steel
RB100BL	1"	NPT	Stainless Steel
RB125BL	1 1/4"	NPT	Stainless Steel
RB150BL	1 1/2"	NPT	Stainless Steel
RB200BL	2"	NPT	Stainless Steel
RB300BL	3"	NPT	Stainless Steel
RB400BL	4"	NPT	Stainless Steel
IB075	3/4"	NPT	Plated Malleable Iron
IB100	1"	NPT	Plated Malleable Iron
IB150	1 1/2"	NPT	Plated Malleable Iron
IB200	2"	NPT	Plated Malleable Iron
IB300	3"	NPT	Plated Malleable Iron
IB400	4"	NPT	Plated Malleable Iron

** “Boss-Lock” Couplers with BSPT threads are available to special order / minimum quantity may apply with the exception of 2 1/2" which is which is only available in NPT.

“EZ BOSS-LOCK” TYPE B - ‘FEMALE COUPLER x MALE’



PART NO.	SIZE	THREAD AVAILABLE	MATERIAL
RB050EZ	3/4" x 1/2"	NPT	Stainless Steel
RB075EZ	3/4"	NPT	Stainless Steel
RB100EZ	1"	NPT	Stainless Steel
RB125EZ	1 1/4"	NPT	Stainless Steel
RB150EZ	1 1/2"	NPT	Stainless Steel
RB200EZ	2"	NPT	Stainless Steel
RB300EZ	3"	NPT	Stainless Steel
RB400EZ	4"	NPT	Stainless Steel
RB600EZ	6"	NPT	Stainless Steel
RB050EZA	3/4" x 1/2"	BSPT	Stainless Steel
RB075EZA	3/4"	BSPT	Stainless Steel
RB100EZA	1"	BSPT	Stainless Steel
RB125EZA	1 1/4"	BSPT	Stainless Steel
RB150EZA	1 1/2"	BSPT	Stainless Steel
RB200EZA	2"	BSPT	Stainless Steel
RB300EZA	3"	BSPT	Stainless Steel
RB400EZA	4"	BSPT	Stainless Steel
RB600EZA	6"	BSPT	Stainless Steel

DIXON CAM & GROOVE TYPE C COUPLER A-A-59326B



PART NO.	SIZE	MATERIAL
50CAL	1/2"	Aluminium
75CAL	3/4"	Aluminium
100CAL	1"	Aluminium
125CAL	1 1/4"	Aluminium
150CAL	1 1/2"	Aluminium
200CAL	2"	Aluminium
250CAL	2 1/2"	Aluminium
300CAL	3"	Aluminium
400CAL	4"	Aluminium
500CAL	5"	Aluminium
600CAL	6"	Aluminium
800CAL	8"	Aluminium
DAL50C	1/2"	Die Cast Aluminium
DAL75C	3/4"	Die Cast Aluminium
DAL100C	1"	Die Cast Aluminium
DAL125C	1 1/4"	Die Cast Aluminium
DAL150C	1 1/2"	Die Cast Aluminium
DAL200C	2"	Die Cast Aluminium
DAL250C	2 1/2"	Die Cast Aluminium
DAL300C	3"	Die Cast Aluminium
DAL400C	4"	Die Cast Aluminium
DAL600C	6"	Die Cast Aluminium
50CBR	1/2"	Brass
75CBR	3/4"	Brass
100CBR	1"	Brass
125CBR	1 1/4"	Brass
150CBR	1 1/2"	Brass
200CBR	2"	Brass
250CBR	2 1/2"	Brass
300CBR	3"	Brass
400CBR	4"	Brass
500CBR	5"	Brass
600CBR	6"	Brass
50CSS	1/2"	Stainless Steel
75CSS	3/4"	Stainless Steel
100CSS	1"	Stainless Steel
125CSS	1 1/4"	Stainless Steel
150CSS	1 1/2"	Stainless Steel
200CSS	2"	Stainless Steel
250CSS	2 1/2"	Stainless Steel
300CSS	3"	Stainless Steel
400CSS	4"	Stainless Steel
500CSS	5"	Stainless Steel
600CSS	6"	Stainless Steel
75CPP	3/4"	Polypropylene
100CPP	1"	Polypropylene
125CPP	1 1/2" x 1 1/4"	Polypropylene
150CPP	1 1/2"	Polypropylene
200CPP	2"	Polypropylene
300CPP	3"	Polypropylene
400CPP	4"	Polypropylene

"ANDREWS" TYPE C - 'REDUCING FEMALE COUPLER x HOSE TAIL'



PART NO.	SIZE	MATERIAL
3020-C-AL	3" x 2"	Aluminium
3040-C-AL	3" x 4"	Aluminium
4030-C-AL	4" x 3"	Aluminium

Also available in Stainless Steel upon request

B



"BOSS-LOCK" TYPE C - 'FEMALE COUPLER x HOSE TAIL'				
PART NO.	SIZE	MATERIAL		
AC075	3/4"	Aluminium		
AC100	1"	Aluminium		
AC125	1 1/4"	Aluminium		
AC150	1 1/2"	Aluminium		
AC200	2"	Aluminium		
AC250	2 1/2"	Aluminium		
AC300	3"	Aluminium		
AC400	4"	Aluminium		
AC600	6"	Aluminium		
BC075	3/4"	Brass		
BC100	1"	Brass		
BC125	1 1/4"	Brass		
BC150	1 1/2"	Brass		
BC200	2"	Brass		
BC250	2 1/2"	Brass		
BC300	3"	Brass		
BC400	4"	Brass		
BC600	6"	Brass		
RC050BL	3/4" x 1/2"	Stainless Steel		
RC075BL	3/4"	Stainless Steel		
RC100BL	1"	Stainless Steel		
RC125BL	1 1/4"	Stainless Steel		
RC150BL	1 1/2"	Stainless Steel		
RC200BL	2"	Stainless Steel		
RC300BL	3"	Stainless Steel		
RC400BL	4"	Stainless Steel		
IC075	3/4"	Plated Malleable Iron		
IC100	1"	Plated Malleable Iron		
IC150	1 1/2"	Plated Malleable Iron		
IC200	2"	Plated Malleable Iron		
IC300	3"	Plated Malleable Iron		
IC400	4"	Plated Malleable Iron		
IC600	6"	Plated Malleable Iron		



"EZ BOSS-LOCK" TYPE C - 'FEMALE COUPLER x HOSE TAIL'				
PART NO.	SIZE	MATERIAL		
RC050EZ	1/2"	Stainless Steel		
RC075EZ	3/4"	Stainless Steel		
RC100EZ	1"	Stainless Steel		
RC125EZ	1 1/4"	Stainless Steel		
RC200EZ	2"	Stainless Steel		
RC300EZ	3"	Stainless Steel		
RC400EZ	4"	Stainless Steel		
RC600EZ	6"	Stainless Steel		

Note: All "Boss-Lock" Couplers come with SAFETY CLIPS. * "Andrews" and "Boss-Lock" Cam and Groove Couplings **DO NOT INTERCHANGE IN THE 8" SIZE**. The 8" "Boss-Lock" design has 2 cam arms. The 8" "Boss-Lock" were designed to interchange with 8" Cam and Groove couplings manufactured by others.



"BOSS-LOCK" TYPE C - 'COUPLER x HOSE TAIL WITH FERRULE'				
PART NO.	SIZE	MINIMUM HOSE O.D.	MAXIMUM HOSE O.D.	MATERIAL
RC075EZ-70	3/4"	1 6/64"	1 22/64"	Stainless Steel
RC100EZ-20	1"	1 29/64"	1 35/64"	Stainless Steel
RC100EZ-70	1"	1 9/16"	1 11/16"	Stainless Steel

Developed specifically for chemical transport hoses having Crosslinked Polyethylene (XLPE) or Ultra High Molecular Weight Polyethylene (UHMWPE) tubes. Swaged "Boss-Lock" provides you with a permanently attached Cam and Groove fitting when superior coupling retention is required. In testing tank transport hoses from a wide variety of manufacturers, the Swaged "Boss-Lock" fitting proved itself to be the clear winner in overall performance.

Fittings are also available on special order for other sizes or hoses O.D.'s. Consult Dixon for pricing and availability of the special equipment required for installation.

DIXON CAM & GROOVE TYPE D COUPLER x BSP PL. & NPT THREADS A-A-59326B

BSP PL. PART NO.	NPT PART NO.	SIZE	MATERIAL
50DALB	50DALN	1/2"	Aluminium
75DALB	75DALN	3/4"	Aluminium
100DALB	100DALN	1"	Aluminium
125DALB	125DALN	1 1/4"	Aluminium
150DALB	150DALN	1 1/2"	Aluminium
200DALB	200DALN	2"	Aluminium
250DALB	250DALN	2 1/2"	Aluminium
300DALB	300DALN	3"	Aluminium
400DALB	400DALN	4"	Aluminium
500DALB	500DALN	5"	Aluminium
600DALB	600DALN	6"	Aluminium
800DALB	800DALN	8"	Aluminium
DAL50 DB	DAL50 DN	1/2"	Die Cast Aluminium
DAL75 DB	DAL75 DN	3/4"	Die Cast Aluminium
DAL100 DB	DAL100 DN	1"	Die Cast Aluminium
DAL125 DB	DAL125 DN	1 1/4"	Die Cast Aluminium
DAL150 DB	DAL150 DN	1 1/2"	Die Cast Aluminium
DAL200 DB	DAL200 DN	2"	Die Cast Aluminium
DAL250 DB	DAL250 DN	2 1/2"	Die Cast Aluminium
DAL300 DB	DAL300 DN	3"	Die Cast Aluminium
DAL400 DB	DAL400 DN	4"	Die Cast Aluminium
50DBRB	50DBRN	1/2"	Brass
75DBRB	75DBRN	3/4"	Brass
100DBRB	100DBRN	1"	Brass
125DBRB	125DBRN	1 1/4"	Brass
150DBRB	150DBRN	1 1/2"	Brass
200DBRB	200DBRN	2"	Brass
250DBRB	250DBRN	2 1/2"	Brass
300DBRB	300DBRN	3"	Brass
400DBRB	400DBRN	4"	Brass
500DBRB	500DBRN	5"	Brass
600DBRB	600DBRN	6"	Brass
50DSSB	50DSSN	1/2"	Stainless Steel
75DSSB	75DSSN	3/4"	Stainless Steel
100DSSB	100DSSN	1"	Stainless Steel
125DSSB	125DSSN	1 1/4"	Stainless Steel
150DSSB	150DSSN	1 1/2"	Stainless Steel
200DSSB	200DSSN	2"	Stainless Steel
250DSSB	250DSSN	2 1/2"	Stainless Steel
300DSSB	300DSSN	3"	Stainless Steel
400DSSB	400DSSN	4"	Stainless Steel
500DSSB	500DSSN	5"	Stainless Steel
600DSSB	600DSSN	6"	Stainless Steel
75DPPB	75DPPN	3/4"	Polypropylene
100DPPB	100DPPN	1"	Polypropylene
125DPPB	125DPPN	1 1/2" x 1 1/4"	Polypropylene
150DPPB	150DPPN	1 1/2"	Polypropylene
200DPPB	200DPPN	2"	Polypropylene
300DPPB	300DPPN	3"	Polypropylene
400DPPB	400DPPN	4"	Polypropylene

"ANDREWS" TYPE D - 'REDUCER COUPLER x FEMALE THREAD'

PART NO.	SIZE	THREAD AVAILABLE	MATERIAL
1510-D-AL	1 1/2" x 1"	NPT	Aluminium
2015-D-AL	2" x 1 1/2"	NPT	Aluminium
3020-D-AL	3" x 2"	NPT	Aluminium
4030-D-AL	4" x 3"	NPT	Aluminium
4030-D-BR	4" x 3"	NPT	Brass
2015-D-SS	2" x 1 1/2"	NPT	Stainless Steel

* "Andrews" and "Boss-Lock" Cam and Groove Couplings **DO NOT INTERCHANGE IN THE 8" SIZE.**

The 8" "Boss-Lock" design has 2 cam arms. The 8" "Boss-Lock" were designed to interchange with 8" Cam and Groove couplings manufactured by others.

B



"BOSS-LOCK" TYPE D 'FEMALE COUPLER x FEMALE THREAD'			
PART NO.	SIZE	THREAD AVAILABLE	MATERIAL
AD050	3/4" x 1/2"	NPT	Aluminium
AD075	3/4"	NPT	Aluminium
AD100	1"	NPT	Aluminium
AD125	1 1/4"	NPT	Aluminium
AD150	1 1/2"	NPT	Aluminium
AD200	2"	NPT	Aluminium
AD250	2 1/2"***	NPT	Aluminium
AD300	3"	NPT	Aluminium
AD400	4"	NPT	Aluminium
AD600	6"	NPT	Aluminium
AD800	8"	NPT	Aluminium
BD050	3/4" x 1/2"	NPT	Brass
BD075	3/4"	NPT	Brass
BD100	1"	NPT	Brass
BD125	1 1/4"	NPT	Brass
BD150	1 1/2"	NPT	Brass
BD200	2"	NPT	Brass
BD250	2 1/2"***	NPT	Brass
BD300	3"	NPT	Brass
BD400	4"	NPT	Brass
BD600	6"	NPT	Brass
RD050	3/4" x 1/2"	NPT	Stainless Steel
RD075	3/4"	NPT	Stainless Steel
RD100	1"	NPT	Stainless Steel
RD125	1 1/4"	NPT	Stainless Steel
RD150	1 1/2"	NPT	Stainless Steel
RD200	2"	NPT	Stainless Steel
RD300	3"	NPT	Stainless Steel
RD400	4"	NPT	Stainless Steel
ID075	3/4"	NPT	Plated Malleable Iron
ID100	1"	NPT	Plated Malleable Iron
ID150	1 1/2"	NPT	Plated Malleable Iron
ID200	2"	NPT	Plated Malleable Iron
ID300	3"	NPT	Plated Malleable Iron
ID400	4"	NPT	Plated Malleable Iron
ID600	6"	NPT	Plated Malleable Iron

** "Boss-Lock" Couplers with BSPT threads are available to special order / minimum quantity may apply with the exception of 2 1/2" which is only available in NPT.

"EZ BOSS-LOCK" TYPE D - 'FEMALE COUPLER x FEMALE THREAD'



PART NO.	SIZE	THREAD AVAILABLE	MATERIAL
RD050EZ	1/2"	NPT	Stainless Steel
RD075EZ	3/4"	NPT	Stainless Steel
RD100EZ	1"	NPT	Stainless Steel
RD125EZ	1 1/4"	NPT	Stainless Steel
RD150EZ	1 1/2"	NPT	Stainless Steel
RD200EZ	2"	NPT	Stainless Steel
RD300EZ	3"	NPT	Stainless Steel
RD400EZ	4"	NPT	Stainless Steel

Note: "Boss-Lock" Couplers with BSPT threads are available to special order.

All "Boss-Lock" Couplers come with SAFETY CLIPS. * "Andrews" and "Boss-Lock" Cam and Groove Couplings **DO NOT INTERCHANGE IN THE 8" SIZE**. The 8"

"Boss-Lock" design has 2 cam arms. The 8" "Boss-Lock" were designed to interchange with 8" Cam and Groove couplings manufactured by others.

DIXON CAM & GROOVE TYPE E ADAPTER A-A-59326B



PART NO.	SIZE	MATERIAL
50EAL	1/2"	Aluminium
75EAL	3/4"	Aluminium
100EAL	1"	Aluminium
125EAL	1 1/4"	Aluminium
150EAL	1 1/2"	Aluminium
200EAL	2"	Aluminium
250EAL	2 1/2"	Aluminium
300EAL	3"	Aluminium
400EAL	4"	Aluminium
500EAL	5"	Aluminium
600EAL	6"	Aluminium
800EAL	8"	Aluminium
DAL50 E	1/2"	Die Cast Aluminium
DAL75 E	3/4"	Die Cast Aluminium
DAL100 E	1"	Die Cast Aluminium
DAL125 E	1 1/4"	Die Cast Aluminium
DAL150 E	1 1/2"	Die Cast Aluminium
DAL200 E	2"	Die Cast Aluminium
DAL250 E	2 1/2"	Die Cast Aluminium
DAL300 E	3"	Die Cast Aluminium
DAL400 E	4"	Die Cast Aluminium
50EBR	1/2"	Brass
75EBR	3/4"	Brass
100EBR	1"	Brass
125EBR	1 1/4"	Brass
150EBR	1 1/2"	Brass
200EBR	2"	Brass
250EBR	2 1/2"	Brass
300EBR	3"	Brass
400EBR	4"	Brass
500EBR	5"	Brass
600EBR	6"	Brass
50ESS	1/2"	Stainless Steel
75ESS	3/4"	Stainless Steel
100ESS	1"	Stainless Steel
125ESS	1 1/4"	Stainless Steel
150ESS	1 1/2"	Stainless Steel
200ESS	2"	Stainless Steel
250ESS	2 1/2"	Stainless Steel
300ESS	3"	Stainless Steel
400ESS	4"	Stainless Steel
500ESS	5"	Stainless Steel
600ESS	6"	Stainless Steel
75EPP	3/4"	Polypropylene
100EPP	1"	Polypropylene
125EPP	1 1/2" x 1 1/4"	Polypropylene
150EPP	1 1/2"	Polypropylene
200EPP	2"	Polypropylene
300EPP	3"	Polypropylene
400EPP	4"	Polypropylene

* "Andrews" and "Boss-Lock" Cam and Groove Couplings

DO NOT INTERCHANGE IN THE 8" SIZE The 8" "Andrews" design has 4 cam arms.



B

“ANDREWS” TYPE E - ‘REDUCER MALE x HOSE TAIL’

PART NO.	SIZE	MATERIAL
4030-E-AL	4" x 3"	Aluminium



“BOSS-LOCK” TYPE E - ‘ADAPTER x HOSE TAIL WITH FERRULE’

PART NO.	SIZE	MINIMUM HOSE O.D.	MAXIMUM HOSE O.D.	MATERIAL
RE075-1370	3/4"	1 ⁶ / ₆₄ "	1 ²² / ₆₄ "	Stainless Steel
RE100-1620	1"	1 ²⁹ / ₆₄ "	1 ³⁵ / ₆₄ "	Stainless Steel
RE100-1770	1"	1 ⁹ / ₁₆ "	1 ¹¹ / ₁₆ "	Stainless Steel

Developed specifically for chemical transport hoses having Crosslinked Polyethylene (XPLE) or Ultra HIGH Molecular Weight Polyethylene (UHMWPE) tubes. Swaged “Boss-Lock” provides you with a permanently attached Cam and Groove fitting when superior coupling retention is required.

In testing tank transport hoses from a wide variety of manufacturers, the Swaged “Boss-Lock” fitting proved itself to be superior in overall performance.

Fittings are also available on special order for other sizes or hoses O.D.'s. Consult the factory for pricing and availability. Consult Dixon for pricing and availability of the special equipment required for installation.

DIXON CAM & GROOVE TYPE F ADAPTER X BSPT & NPT A-A-59326B



BSPT PART NO.	NPT PART NO.	SIZE	MATERIAL
50FALB	50FALN	1/2"	Aluminium
75FALB	75FALN	3/4"	Aluminium
100FALB	100FALN	1"	Aluminium
125FALB	125FALN	1 1/4"	Aluminium
150FALB	150FALN	1 1/2"	Aluminium
200FALB	200FALN	2"	Aluminium
250FALB	250FALN	2 1/2"	Aluminium
300FALB	300FALN	3"	Aluminium
400FALB	400FALN	4"	Aluminium
500FALB	500FALN	5"	Aluminium
600FALB	600FALN	6"	Aluminium
DAL50 FB	DAL50 FN	1/2"	Die Cast Aluminium
DAL75 FB	DAL75 FN	3/4"	Die Cast Aluminium
DAL100 FB	DAL100 FN	1"	Die Cast Aluminium
DAL125 FB	DAL125 FN	1 1/4"	Die Cast Aluminium
DAL150 FB	DAL150 FN	1 1/2"	Die Cast Aluminium
DAL200 FB	DAL200 FN	2"	Die Cast Aluminium
DAL250 FB	DAL250 FN	2 1/2"	Die Cast Aluminium
DAL300 FB	DAL300 FN	3"	Die Cast Aluminium
DAL400 FB	DAL400 FN	4"	Die Cast Aluminium
50FBRB	50FBRN	1/2"	Brass
75FBRB	75FBRN	3/4"	Brass
100FBRB	100FBRN	1"	Brass
125FBRB	125FBRN	1 1/4"	Brass
150FBRB	150FBRN	1 1/2"	Brass
200FBRB	200FBRN	2"	Brass
250FBRB	250FBRN	2 1/2"	Brass
300FBRB	300FBRN	3"	Brass
400FBRB	400FBRN	4"	Brass
500FBRB	500FBRN	5"	Brass
600FBRB	600FBRN	6"	Brass
50FSSB	50FSSN	1/2"	Stainless Steel
75FSSB	75FSSN	3/4"	Stainless Steel
100FSSB	100FSSN	1"	Stainless Steel
125FSSB	125FSSN	1 1/4"	Stainless Steel
150FSSB	150FSSN	1 1/2"	Stainless Steel
200FSSB	200FSSN	2"	Stainless Steel
250FSSB	250FSSN	2 1/2"	Stainless Steel
300FSSB	300FSSN	3"	Stainless Steel
400FSSB	400FSSN	4"	Stainless Steel
500FSSB	500FSSN	5"	Stainless Steel
600FSSB	600FSSN	6"	Stainless Steel
75FPPB	75FPPN	3/4"	Polypropylene
100FPPB	100FPPN	1"	Polypropylene
125FPPB	125FPPN	1 1/2" x 1 1/4"	Polypropylene
150FPPB	150FPPN	1 1/2"	Polypropylene
200FPPB	200FPPN	2"	Polypropylene
300FPPB	300FPPN	3"	Polypropylene
400FPPB	400FPPN	4"	Polypropylene



"ANDREWS" TYPE F - 'REDUCER ADAPTER x MALE THREAD'

PART NO.	SIZE	THREAD AVAILABLE	MATERIAL
3020-F-SS	3" x 2"	NPT	Stainless Steel

B



DIXON CAM & GROOVE TYPE DUST PLUG ADAPTER A-A-59326B

PART NO.	SIZE	MATERIAL
50DPAL	1/2"	Aluminium
75DPAL	3/4"	Aluminium
100DPAL	1"	Aluminium
125DPAL	1 1/4"	Aluminium
150DPAL	1 1/2"	Aluminium
200DPAL	2"	Aluminium
250DPAL	2 1/2"	Aluminium
300DPAL	3"	Aluminium
400DPAL	4"	Aluminium
500DPAL	5"	Aluminium
600DPAL	6"	Aluminium
800DPAL	8"	Aluminium
DAL50 DP	1/2"	Die Cast Aluminium
DAL75 DP	3/4"	Die Cast Aluminium
DAL100 DP	1"	Die Cast Aluminium
DAL125 DP	1 1/4"	Die Cast Aluminium
DAL150 DP	1 1/2"	Die Cast Aluminium
DAL200 DP	2"	Die Cast Aluminium
DAL250 DP	2 1/2"	Die Cast Aluminium
DAL300 DP	3"	Die Cast Aluminium
DAL400 DP	4"	Die Cast Aluminium
50DPBR	1/2"	Brass
75DPBR	3/4"	Brass
100DPBR	1"	Brass
125DPBR	1 1/4"	Brass
150DPBR	1 1/2"	Brass
200DPBR	2"	Brass
250DPBR	2 1/2"	Brass
300DPBR	3"	Brass
400DPBR	4"	Brass
500DPBR	5"	Brass
600DPBR	6"	Brass
50DPSS	1/2"	Stainless Steel
75DPSS	3/4"	Stainless Steel
100DPSS	1"	Stainless Steel
125DPSS	1 1/4"	Stainless Steel
150DPSS	1 1/2"	Stainless Steel
200DPSS	2"	Stainless Steel
250DPSS	2 1/2"	Stainless Steel
300DPSS	3"	Stainless Steel
400DPSS	4"	Stainless Steel
500DPSS	5"	Stainless Steel
600DPSS	6"	Stainless Steel
75DPPP	3/4"	Polypropylene
100DPPP	1"	Polypropylene
150DPPP	1 1/2"	Polypropylene
200DPPP	2"	Polypropylene
300DPPP	3"	Polypropylene
400DPPP	4"	Polypropylene

DIXON CAM & GROOVE TYPE DUST CAP COUPLER A-A-59326B



PART NO.	SIZE	MATERIAL
50DCAL	1/2"	Aluminium
75DCAL	3/4"	Aluminium
100DCAL	1"	Aluminium
125DCAL	1 1/4"	Aluminium
150DCAL	1 1/2"	Aluminium
200DCAL	2"	Aluminium
250DCAL	2 1/2"	Aluminium
300DCAL	3"	Aluminium
400DCAL	4"	Aluminium
500DCAL	5"	Aluminium
600DCAL	6"	Aluminium
800DCAL	8"	Aluminium
DAL50DC	1/2"	Die Cast Aluminium
DAL75DC	3/4"	Die Cast Aluminium
DAL100DC	1"	Die Cast Aluminium
DAL125DC	1 1/4"	Die Cast Aluminium
DAL150DC	1 1/2"	Die Cast Aluminium
DAL200DC	2"	Die Cast Aluminium
DAL250DC	2 1/2"	Die Cast Aluminium
DAL300DC	3"	Die Cast Aluminium
DAL400DC	4"	Die Cast Aluminium
50DCBR	1/2"	Brass
75DCBR	3/4"	Brass
100DCBR	1"	Brass
125DCBR	1 1/4"	Brass
150DCBR	1 1/2"	Brass
200DCBR	2"	Brass
250DCBR	2 1/2"	Brass
300DCBR	3"	Brass
400DCBR	4"	Brass
500DCBR	5"	Brass
600DCBR	6"	Brass
50DCSS	1/2"	Stainless Steel
75DCSS	3/4"	Stainless Steel
100DCSS	1"	Stainless Steel
125DCSS	1 1/4"	Stainless Steel
150DCSS	1 1/2"	Stainless Steel
200DCSS	2"	Stainless Steel
250DCSS	2 1/2"	Stainless Steel
300DCSS	3"	Stainless Steel
400DCSS	4"	Stainless Steel
500DCSS	5"	Stainless Steel
600DCSS	6"	Stainless Steel
75DCPP	3/4"	Polypropylene
100DCPP	1"	Polypropylene
150DCPP	1 1/2"	Polypropylene
200DCPP	2"	Polypropylene
300DCPP	3"	Polypropylene
400DCPP	4"	Polypropylene

Note: All "Boss-Lock" Couplers come with SAFETY CLIPS. * "Andrews" and "Boss-Lock"

Cam and Groove Couplings **DO NOT INTERCHANGE IN THE 8" SIZE.**

The 8" "Boss-Lock" design has 2 cam arms. The 8" "Boss-Lock" were designed to interchange with 8" Cam and Groove couplings manufactured by others.

B



"ANDREWS" LOCKABLE DUST CAP

PART NO.	SIZE	MATERIAL
200-DC-L-AL	2"	Aluminium
300-DC-L-AL	3"	Aluminium
400-DC-L-AL	4"	Aluminium
600-DC-L-AL	6"	Aluminium
200-DC-L-BR	2"	Brass
300-DC-L-BR	3"	Brass
400-DC-L-BR	4"	Brass
200DC-L-SS	2"	Stainless Steel
300DC-L-SS	3"	Stainless Steel



LOCKING / PADDLE HANDLES FOR "ANDREWS" DUST CAP

PART NO.	COUPLER SIZE	DESCRIPTION
200-LH-BR	2"	Locking Handle, Brass
300-LH-BR	3"	Locking Handle, Brass
400-LH-BR	4"	Locking Handle, Brass
300H-PADBR	3" and 4"	Paddle Handle, Brass

"BOSS-LOCK" - 'DUST CAPS'



PART NO.	SIZE	MATERIAL
AH075	3/4"	Aluminium
AH100	1"	Aluminium
AH125	1 1/4"	Aluminium
AH150	1 1/2"	Aluminium
AH200	2"	Aluminium
AH250	2 1/2"	Aluminium
AH300	3"	Aluminium
AH400	4"	Aluminium
AH600	6"	Aluminium
BH075	3/4"	Brass
BH100	1"	Brass
BH125	1 1/4"	Brass
BH150	1 1/2"	Brass
BH200	2"	Brass
BH250	2 1/2"***	Brass
BH300	3"	Brass
BH400	4"	Brass
BH600	6"	Brass
RH075BL	3/4"	Stainless Steel
RH100BL	1"	Stainless Steel
RH125BL	1 1/4"	Stainless Steel
RH150BL	1 1/2"	Stainless Steel
RH200BL	2"	Stainless Steel
RH300BL	3"	Stainless Steel
RH400BL	4"	Stainless Steel
IH100	1"	Plated Malleable Iron
IH150	1 1/2"	Plated Malleable Iron
IH200	2"	Plated Malleable Iron
IH300	3"	Plated Malleable Iron
IH400	4"	Plated Malleable Iron
IH600	6"	Plated Malleable Iron



'EZ BOSS-LOCK' – 'DUST CAPS'

PART NO.	SIZE	MATERIAL
RH075EZ	3/4"	Stainless Steel
RH100EZ	1"	Stainless Steel
RH125EZ	1 1/4"	Stainless Steel
RH150EZ	1 1/2"	Stainless Steel
RH200EZ	2"	Stainless Steel
RH300EZ	3"	Stainless Steel
RH400EZ	4"	Stainless Steel
RH600EZ	6"	Stainless Steel

Note: All "Boss-Lock" Couplers come with SAFETY CLIPS.

* "Andrews" and "Boss-Lock" Cam and Groove Couplings

DO NOT INTERCHANGE IN THE 8" SIZE. The 8" "Boss-Lock" design has 2 cam arms.

The 8" "Boss-Lock" were designed to interchange with 8" Cam and Groove couplings manufactured by others.



'EZ BOSS-LOCK' COUPLER x ADAPTER

PART NO.	SIZE	MATERIAL
RDA3020EZ	3" x 2"	Stainless Steel
RDA4030EZ	4" x 3"	Stainless Steel

'ANDREWS' - 'REDUCING FEMALE COUPLERS x MALE ADAPTERS'

PART NO.	SIZE / DESCRIPTION	MATERIAL
1510-DA-AL	1 1/2" Coupler x 1" Adapter	Aluminium
1520-DA-AL	1 1/2" Coupler x 2" Adapter	Aluminium
2015-DA-AL	2" Coupler x 1 1/2" Adapter	Aluminium
2030-DA-AL	2" Coupler x 3" Adapter	Aluminium
2040-DA-AL	2" Coupler x 4" Adapter	Aluminium
3015-DA-AL	3" Coupler x 1 1/2" Adapter	Aluminium
3020-DA-AL	3" Coupler x 2" Adapter	Aluminium
3040-DA-AL	3" Coupler x 4" Adapter	Aluminium
4020-DA-AL	4" Coupler x 2" Adapter	Aluminium
4025-DA-AL	4" Coupler x 2 1/2" Adapter	Aluminium
4030-DA-AL	4" Coupler x 3" Adapter	Aluminium
4060-DA-AL	4" Coupler x 6" Adapter	Aluminium
5040-DA-AL	5" Coupler x 4" Adapter	Aluminium
6030-DA-AL	6" Coupler x 3" Adapter	Aluminium
6040-DA-AL	6" Coupler x 4" Adapter	Aluminium
3020-DA-ALH	3" Coupler x 2" Adapter	Aluminium Hard Coat
4030-DA-ALH	4" Coupler x 3" Adapter	Aluminium Hard Coat
3020-DA-BR	3" Coupler x 2" Adapter	Brass
4030-DA-BR	4" Coupler x 3" Adapter	Brass
6040-DA-BR	6" Coupler x 4" Adapter	Brass
3020-DA-MI	3" Coupler x 2" Adapter	Unplated Malleable Iron
4030-DA-MI	4" Coupler x 3" Adapter	Unplated Malleable Iron
6040-DA-MI	6" Coupler x 4" Adapter	Unplated Malleable Iron
1520-DA-SS	1 1/2" Coupler x 2" Adapter	Stainless Steel
2015-DA-SS	2" Coupler x 1 1/2" Adapter	Stainless Steel
2030-DA-SS	2" Coupler x 3" Adapter	Stainless Steel
3020-DA-SS	3" Coupler x 2" Adapter	Stainless Steel
3040-DA-SS	3" Coupler x 4" Adapter	Stainless Steel
4030-DA-SS	4" Coupler x 3" Adapter	Stainless Steel
6040-DA-SS	6" Coupler x 4" Adapter	Stainless Steel



B



“ANDREWS” - ‘MALE x MALE ADAPTER’

PART NO.	SIZE	MATERIAL
150-AA-AL	1 1/2"	Aluminium
1520-AA-AL	1 1/2" x 2"	Aluminium
200-AA-AL	2"	Aluminium
2030-AA-AL	2" x 3"	Aluminium
2040-AA-AL	2" x 4"	Aluminium
300-AA-AL	3"	Aluminium
3040-AA-AL	3" x 4"	Aluminium
400-AA-AL	4"	Aluminium
4060-AA-AL	4" x 6"	Aluminium
600-AA-AL	6"	Aluminium
150-AA-BR	1 1/2"	Brass
200-AA-BR	2"	Brass
300-AA-BR	3"	Brass
100-AA-SS	1"	Stainless Steel
150-AA-SS	1 1/2"	Stainless Steel
1520-AA-SS	1 1/2" x 2"	Stainless Steel
200-AA-SS	2"	Stainless Steel
2030-AA-SS	2" x 3"	Stainless Steel
300-AA-SS	3"	Stainless Steel

90° ELBOW - ‘MALE ADAPTER x FEMALE THREAD’



PART NO.	SIZE	THREAD	MATERIAL
150A-90-AL	1 1/2"	NPT	Aluminium
200A-90-AL	2"	NPT	Aluminium
300A-90-AL	3"	NPT	Aluminium
400A-90-AL	4"	NPT	Aluminium
90PPA150	1 1/2"	NPT	Polypropylene
90PPA200	2"	NPT	Polypropylene
300A-90-SS	3"	NPT	Stainless Steel



90° ELBOW - ‘FEMALE COUPLER x MALE THREAD’

PART NO.	SIZE	THREAD	MATERIAL
150B-90-AL	1 1/2"	NPT	Aluminium
200B-90-AL	2"	NPT	Aluminium



90° ELBOW - ‘FEMALE COUPLER x HOSE TAIL’

PART NO.	SIZE	MATERIAL
150C-90-AL	1 1/2"	Aluminium
200C-90-AL	2"	Aluminium
300C-90-AL	3"	Aluminium
400C-90-AL	4"	Aluminium
90PPC150	1 1/2"	Polypropylene
90PPC200	2"	Polypropylene
300C90-SS	3"	Stainless Steel



90° ELBOW - 'FEMALE COUPLER x FEMALE THREAD'			
PART NO.	SIZE	THREAD	MATERIAL
150D-90-AL	1 1/2"	NPT	Aluminium
200D-90-AL	2"	NPT	Aluminium
300D-90-AL	3"	NPT	Aluminium
400D-90-AL	4"	NPT	Aluminium
90PPD150	1 1/2"	NPT	Polypropylene
90PPD200	2"	NPT	Polypropylene
200D-90-SS	2"	NPT	Stainless Steel
300D-90-SS	3"	NPT	Stainless Steel



90° ELBOW - 'MALE ADAPTER x HOSE TAIL'		
PART NO.	SIZE	MATERIAL
300E-90-AL	3"	Aluminium
400E-90-AL	4"	Aluminium

*All these parts can be manufactured in stainless steel upon request.



90° ELBOW - 'MALE ADAPTER x MALE THREAD'			
PART NO.	SIZE	THREAD	MATERIAL
150F-90-AL	1 1/2"	NPT	Aluminium
200F-90-AL	2"	NPT	Aluminium
90PPF150	1 1/2"	NPT	Polypropylene
90PPF200	2"	NPT	Polypropylene



90° ELBOW - 'FEMALE COUPLER x MALE ADAPTER'		
PART NO.	SIZE	MATERIAL
150DA-90-AL	1 1/2"	Aluminium
200DA-90-AL	2"	Aluminium
300DA-90-AL	3"	Aluminium
400DA-90-AL	4"	Aluminium
600DA-90-AL	6"	Aluminium



90° ELBOW - 'FEMALE x FEMALE COUPLER'		
PART NO.	SIZE	MATERIAL
400DD-90-AL	4"	Aluminium

*All these parts can be manufactured in stainless steel upon request.

B



'Y' PIECE IN ALUMINIUM

PART NO.	DESCRIPTION
200YDAA-AL	2" Coupler x 2" Adapter x 2" Adapter



"ANDREWS" FLANGED COUPLERS AND ADAPTERS

PART NO.	SIZE	MATERIAL
200-AL-AL	2"	Aluminium
300-AL-AL	3"	Aluminium
400-AL-AL	4"	Aluminium
600-AL-AL	6"	Aluminium
100-AL-SS	1"	Stainless Steel
150-AL-SS	1 1/2"	Stainless Steel
200-AL-SS	2"	Stainless Steel
300-AL-SS	3"	Stainless Steel
400-AL-SS	4"	Stainless Steel
600-AL-SS	6"	Stainless Steel
200-DL-AL	2"	Aluminium
300-DL-AL	3"	Aluminium
400-DL-AL	4"	Aluminium
600-DL-AL	6"	Aluminium
100-DL-SS	1"	Stainless Steel
150-DL-SS	1 1/2"	Stainless Steel
200-DL-SS	2"	Stainless Steel
300-DL-SS	3"	Stainless Steel
400-DL-SS	4"	Stainless Steel
600-DL-SS	6"	Stainless Steel

"BOSS-LOCK" STANDARD HANDLE ASSEMBLIES



PART NO.	COUPLER SIZE	DESCRIPTION
BHSC175	3/4" - 1"	Brass
BHSC152	1 1/4" - 2 1/2"	Brass
BHSC34	3" and 4"	Brass
RHSC175	3/4" - 1"	Investment Cast Stainless Steel
RHSC152	1 1/4" - 2 1/2"	Investment Cast Stainless Steel
RHSC34	3" and 4"	Investment Cast Stainless Steel

Assembly includes cam arm, pin and pull ring.



"EZ BOSS-LOCK" STANDARD ASSEMBLY HANDLES

PART NO.	SIZE
BHSC175	3/4" - 1"
BHSC152	1 1/4" - 2"
BHSC34	3" and 4"

Investment Cast Stainless Steel Cam Arm and Lever. 316 Stainless Steel Spring. Stainless Steel Pin and Washer. Plated Carbon Steel Pull Ring.

UNDER NO CIRCUMSTANCES should the EZ Boss-Lock cam arms be used on any fitting not specifically produced for their use.

The EZ Boss-Lock cam arms CANNOT be retrofitted onto existing Aluminium, Brass or Plated Malleable Iron Boss-Lock already in service.



DIXON STANDARD HANDLE ASSEMBLIES			
PART NO.	SIZE	DESCRIPTION	MATERIAL
DSH50	1/2" and 3/4"	Handle, ring and pin	Investment Stainless Steel
DSH100	1"	Handle, ring and pin	Investment Stainless Steel
DSH200	1 1/4" thru 2 1/2"	Handle, ring and pin	Investment Stainless Steel
DSH300	3" and 4"	Handle, ring and pin	Investment Stainless Steel



"ANDREWS" STANDARD HANDLE ASSEMBLIES			
PART NO.	SIZE	DESCRIPTION	MATERIAL
200-HRP-BR	1 1/4" - 2 1/2"	Handle, Ring and Pin	Brass
300-HRP-BR	3" - 5"	Handle, Ring and Pin	Brass
600-HRP-BR	6"	Handle, Ring and Pin	Brass
800-HP-BR	8"	Handle, Ring and Pin	Brass
50-HRP-SP	1/2"	Handle, Ring and Pin	Sintered Stainless Steel
75-HRP-SP	3/4"	Handle, Ring and Pin	Sintered Stainless Steel
100-HRP-SP	1"	Handle, Ring and Pin	Sintered Stainless Steel
200-HRP-SP	1 1/4" - 2 1/2"	Handle, Ring and Pin	Sintered Stainless Steel
300-HRP-SP	3" - 5"	Handle, Ring and Pin	Sintered Stainless Steel
200-HRP-SI	1 1/4" - 2 1/2"	Handle, Ring and Pin	Investment Stainless Steel
300-HRP-SI	3" - 5"	Handle, Ring and Pin	Investment Stainless Steel
600-HRP-SI	6"	Handle, Ring and Pin	Investment Stainless Steel

Stainless Steel Pins are standard with all assemblies. Pull Rings are standard on 1 1/4" to 6", optional on other sizes.

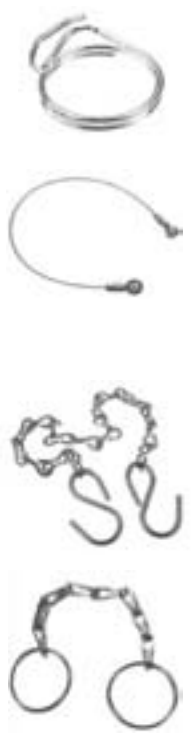

CLIPS, LANYARDS AND PULL RINGS FOR "BOSS-LOCK"	
PART NO.	DESCRIPTION
100PRSCSS	Stainless Steel Pull Ring Safety Clip for Coupler Size 3/4" x 1"
200PRSCSS	Stainless Steel Pull Ring Safety Clip for Coupler Size 1 1/4" x 2 1/2"
300PRSCSS	Stainless Steel Pull Ring Safety Clip for Coupler Size 3" x 4"
ACL2	Carbon Steel Clip with Nylon Lanyard Size 3/4" and 1"
ACL3	Carbon Steel Clip with Nylon Lanyard Size 3" and 4"
ACL4	Carbon Steel Clip with Nylon Lanyard Size 1 1/4" and 2 1/2"
AC7	Stainless Steel Clip
LR7	Stainless Steel Lanyard
BLCA152CS	Carbon Steel Assembly - Pull Ring, Chain and AC3 Clip
CH-B-6	Jack Chain with S-Hooks - 6" Brass
CH-B-12	Jack Chain with S-Hooks - 12" Brass
CH-C-12	Jack Chain with S-Hooks - 12" Carbon Steel
CH-SS-6	Jack Chain with S-Hooks - 6" Stainless Steel
CH-SS-12	Jack Chain with S-Hooks - 12" Stainless Steel
CH-SS-24	Jack Chain with S-Hooks - 24" Stainless Steel
J125	Sash Chain with Plated Steel Pull Rings - 4 1/2" Brass
J150	Sash Chain with Plated Steel Pull Rings - 6 1/2" Brass
J300	Sash Chain with Plated Steel Pull Rings - 8 1/2" Brass
J500	Sash Chain with Plated Steel Pull Rings - 12 1/2" Brass

B

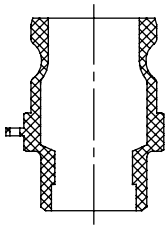
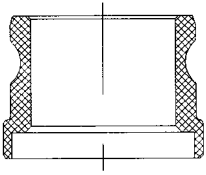

“ANDREWS” ADAPTERS FOR WELDING

PART NO.	SIZE	BORE	MATERIAL
SOCKET WELD TO SCH 40 PIPE			
200AWSPAL	2"	2.390	Aluminium
300AWSPAL	3"	3.530	Aluminium
400AWSPAL	4"	4.530	Aluminium
500AWSPAL	5"	5.593	Aluminium
600AWSPAL	6"	6.655	Aluminium
75AWSPSS	3/4"	1.065	Stainless Steel
100AWSPSS	1"	1.330	Stainless Steel
150AWSPSS	1 1/2"	1.915	Stainless Steel
200AWSPSS	2"	2.390	Stainless Steel
300AWSPSS	3"	3.530	Stainless Steel
400AWSPSS	4"	4.530	Stainless Steel
600AWSPSS	6"	6.655	Stainless Steel
BUTT WELD TO SCH 40 PIPE & SOCKET WELD TO NOMINAL OD TUBING			
200AWBPSTAL	2"	2.390	Aluminium
300AWBPSTAL	3"	3.530	Aluminium
400AWBPSTAL	4"	4.530	Aluminium
600AWBPSTAL	6"	6.655	Aluminium
100AWBPSTSS	1"	1.330	Stainless Steel
150AWBPSTSS	1 1/2"	1.915	Stainless Steel
200AWBPSTSS	2"	2.390	Stainless Steel
300AWBPSTSS	3"	3.530	Stainless Steel
400AWBPSTSS	4"	4.530	Stainless Steel
600AWBPSTSS	6"	6.655	Stainless Steel

“ANDREWS” COUPLERS FOR WELDING

PART NO.	SIZE	BORE	MATERIAL
SOCKET WELD TO SCH 40 PIPE			
200DWSPAL	2"	2.390	Aluminium
300DWSPAL	3"	3.530	Aluminium
400DWSPAL	4"	4.530	Aluminium
600DWSPAL	6"	6.655	Aluminium
100DWSPSS	1"	1.330	Stainless Steel
150DWSPSS	1 1/2"	1.915	Stainless Steel
200DWSPSS	2"	2.390	Stainless Steel
300DWSPSS	3"	3.530	Stainless Steel
400DWSPSS	4"	4.530	Stainless Steel
600DWSPSS	6"	6.655	Stainless Steel
BUTT WELD TO SCH 40 PIPE & SOCKET WELD TO NOMINAL OD TUBING			
300DWBPSTAL	3"	3.530	Aluminium
400DWBPSTAL	4"	4.530	Aluminium
500DWBPSTAL	5"	5.593	Aluminium
600DWBPSTAL	6"	6.655	Aluminium
200DWBPSTSS	2"	2.390	Stainless Steel
300DWBPSTSS	3"	3.530	Stainless Steel
400DWBPSTSS	4"	4.530	Stainless Steel

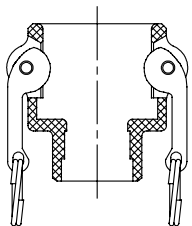
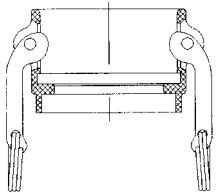

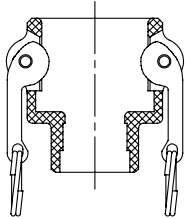
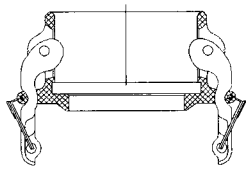

"EZ BOSS-LOCK" COUPLERS FOR WELDING

PART NO.	SIZE	BORE	MATERIAL
SOCKET WELD TO SCH 40 PIPE			
RDWSP100EZ	1"	1.330	Stainless Steel
RDWSP150EZ	1 1/2"	1.915	Stainless Steel
RDWSP200EZ	2"	2.390	Stainless Steel
RDWSP300EZ	3"	3.530	Stainless Steel
RDWSP400EZ	4"	4.530	Stainless Steel
RDWSP600EZ	6"	6.695	Stainless Steel
BUTT WELD TO SCH 40 PIPE & SOCKET WELD TO NOMINAL OD TUBING			
RDWBPST075EZ	3/4"	0.765	Stainless Steel
RDWBPST100EZ	1"	1.330	Stainless Steel
RDWBPST150EZ	1 1/2"	1.915	Stainless Steel
RDWBPST200EZ	2"	2.390	Stainless Steel
RDWBPST300EZ	3"	3.530	Stainless Steel
RDWBPST400EZ	4"	4.530	Stainless Steel
RDWBPST600EZ	6"	6.655	Stainless Steel



"EZ BOSS-LOCK" - 'FEMALE COUPLER x MALE ADAPTER'

PART NO.	SIZE	MATERIAL
ADA3020	3" x 2"	Aluminium
ADA4030	4" X 3"	Aluminium
RDA3020BL	3" x 2"	Stainless Steel
RDA4030BL	4" x 3"	Stainless Steel

King Crimp Cam & Groove

B

SAFETY ALERT

Only use the crimp style shanks with the crimp style sleeves and ferrules.
Due to differences in dimensions and tolerances for safety reasons, do not interchange other manufacturer's products with Dixon products.



EZ BOSS-LOCK TYPE C COUPLERS

PART NO.	316 STAINLESS STEEL HOSE ID
RC100EZCR	1"
RC150EZCR	1 1/2"
RC200EZCR	2"
RC300EZCR	3"
RC400EZCR	4"
RC600EZCR	6"



TYPE C COUPLER

ALUMINIUM* PART NO.	BRASS PART NO.	STAINLESS STEEL PART NO.	HOSE ID
100-C-EC-AL	100-C-EC-BR	100-C-EC-SS	1"
150-C-EC-AL	150-C-EC-BR	150-C-EC-SS	1 1/2"
200-C-EC-AL	200-C-EC-BR	200-C-EC-SS	2"
300-C-EC-AL	300-C-EC-BR	300-C-EC-SS	3"
400-C-EC-AL	400-C-EC-BR	400-C-EC-SS	4"

*A380 permanent mold aluminium



TYPE E ADAPTERS

ALUMINIUM* PART NO.	BRASS PART NO.	STAINLESS STEEL PART NO.	HOSE ID
100-E-EC-AL	100-E-EC-BR	100-E-EC-SS	1"
150-E-EC-AL	150-E-EC-BR	150-E-EC-SS	1 1/2"
200-E-EC-AL	200-E-EC-BR	200-E-EC-SS	2"
300-E-EC-AL	300-E-EC-BR	300-E-EC-SS	3"
400-E-EC-AL	400-E-EC-BR	400-E-EC-SS	4"

*A380 permanent mold aluminium



CRIMP STYLE FERRULES

CARBON STEEL PART NO.	304 STAINLESS STEEL PART NO.	HOSE ID	HOSE OD	
			FROM	TO
CF100-1CS	CF100-1SS	1"	30.56	31.75
CF100-2CS	CF100-2SS		32.15	33.34
CF100-3CS	CF100-3SS		33.73	34.93
CF100-4CS	CF100-4SS		35.32	36.51
CF100-5CS	CF100-5SS		36.91	38.10
CF100-6CS	CF100-6SS		38.50	39.69
CF100-7CS	CF100-7SS		40.08	41.28
CF100-8CS	CF100-8SS		41.67	42.86
CF100-9CS	CF100-9SS		43.26	44.45
CF100-10CS	CF100-10SS		44.85	46.04
CF150-1CS	CF150-1SS	1½"	41.67	42.86
CF150-2CS	CF150-2SS		43.26	44.45
CF150-3CS	CF150-3SS		44.85	46.04
CF150-4CS	CF150-4SS		46.43	47.63
CF150-5CS	CF150-5SS		48.02	49.21
CF150-6CS	CF150-6SS		49.61	50.80
CF150-7CS	CF150-7SS		51.20	52.39
CF150-8CS	CF150-8SS		52.78	53.98
CF150-9CS	CF150-9SS		54.37	55.56
CF150-10CS	CF150-10SS		55.96	57.15
CF150-11CS	CF150-11SS		57.55	58.74
CF150-12CS	CF150-12SS		59.13	60.33
CF200-1CS	CF200-1SS	2"	55.96	57.15
CF200-2CS	CF200-2SS		57.55	58.74
CF200-3CS	CF200-3SS		59.13	60.33
CF200-4CS	CF200-4SS		60.72	61.91
CF200-5CS	CF200-5SS		62.31	63.50
CF200-6CS	CF200-6SS		63.90	65.09
CF200-7CS	CF200-7SS		65.48	66.68
CF200-8CS	CF200-8SS		67.07	68.26
CF200-9CS	CF200-9SS		68.66	69.85
CF200-10CS	CF200-10SS		70.25	71.44
CF200-11CS	CF200-11SS		71.83	73.03
CF200-12CS	CF200-12SS		73.42	74.61
CF300-1CS	CF300-1SS	3"	81.36	82.55
CF300-2CS	CF300-2SS		82.95	84.14
CF300-3CS	CF300-3SS		84.53	85.73
CF300-4CS	CF300-4SS		86.12	87.31
CF300-5CS	CF300-5SS		87.71	88.90
CF300-6CS	CF300-6SS		89.30	90.49
CF300-7CS	CF300-7SS		90.88	92.08
CF300-8CS	CF300-8SS		92.47	93.66
CF300-9CS	CF300-9SS		94.06	95.25
CF300-10CS	CF300-10SS		95.65	96.84
CF300-11CS	CF300-11SS		97.23	98.43
CF300-12CS	CF300-12SS		98.82	100.01
CF300-13CS	CF300-13SS		100.41	101.60
CF300-14CS	CF300-14SS		102.00	103.19
CF300-15CS	CF300-15SS		103.58	104.78
CF300-16CS	CF300-16SS		105.17	106.36
CF400-1CS	CF400-1SS	4"	106.76	107.95
CF400-2CS	CF400-2SS		108.35	109.54
CF400-3CS	CF400-3SS		109.93	111.13
CF400-4CS	CF400-4SS		111.52	112.71
CF400-5CS	CF400-5SS		113.11	114.30
CF400-6CS	CF400-6SS		114.70	115.89
CF400-7CS	CF400-7SS		116.28	117.48
CF400-8CS	CF400-8SS		117.87	119.06
CF400-9CS	CF400-9SS		119.46	120.65
CF400-10CS	CF400-10SS		121.05	122.24
CF400-11CS	CF400-11SS		122.63	123.83
CF400-12CS	CF400-12SS		124.22	125.41
CF400-13CS	CF400-13SS	125.81	127.00	
CF400-14CS	CF400-14SS	127.40	128.59	
CF400-15CS	CF400-15SS	128.98	130.18	
CF400-16CS	CF400-16SS	130.57	131.76	
CF600-1CS	CF600-1SS	6"	160.73	163.51
CF600-2CS	CF600-2SS		163.91	166.69
CF600-3CS	CF600-3SS		167.08	169.86
CF600-4CS	CF600-4SS		170.26	173.04
CF600-5CS	CF600-5SS		173.43	176.39
CF600-6CS	CF600-6SS		176.61	179.39
CF600-7CS	CF600-7SS		179.78	182.56
CF600-8CS	CF600-8SS		182.96	185.74
CF600-9CS	CF600-9SS		186.13	188.91

SAFETY ALERT

Only use the crimp style shanks with the crimp style sleeves and ferrules.

Due to differences in dimensions and tolerances for safety reasons, do not interchange other manufacturer's products with Dixon products.

B



CRIMP STYLE SLEEVES

CARBON STEEL PART NO.	304 STAINLESS STEEL PART NO.	ALUMINIUM PART NO.	HOSE ID	HOSE OD		
				FROM	TO	
CS100-1CS	CS100-1SS	CS100-1AL	1"	30.56	31.75	
CS100-2CS	CS100-2SS	CS100-2AL		32.15	33.34	
CS100-3CS	CS100-3SS	CS100-3AL		33.73	34.93	
CS100-4CS	CS100-4SS	CS100-4AL		35.32	36.51	
CS100-5CS	CS100-5SS	CS100-5AL		36.91	38.10	
CS100-6CS	CS100-6SS	CS100-6AL		38.50	39.69	
CS100-7CS	CS100-7SS	CS100-7AL		40.08	41.28	
CS100-8CS	CS100-8SS	CS100-8AL		41.67	42.86	
CS100-9CS	CS100-9SS	CS100-9AL		43.26	44.45	
CS100-10CS	CS100-10SS	CS100-10AL		44.85	46.04	
CS150-1CS	CS150-1SS	CS150-1AL		1½"	41.67	42.86
CS150-2CS	CS150-2SS	CS150-2AL			43.26	44.45
CS150-3CS	CS150-3SS	CS150-3AL	44.85		46.04	
CS150-4CS	CS150-4SS	CS150-4AL	46.43		47.63	
CS150-5CS	CS150-5SS	CS150-5AL	48.02		49.21	
CS150-6CS	CS150-6SS	CS150-6AL	49.61		50.80	
CS150-7CS	CS150-7SS	CS150-7AL	51.20		52.39	
CS150-8CS	CS150-8SS	CS150-8AL	52.78		53.98	
CS150-9CS	CS150-9SS	CS150-9AL	54.37		55.56	
CS150-10CS	CS150-10SS	CS150-10AL	55.96		57.15	
CS150-11CS	CS150-11SS	CS150-11AL	57.55		58.74	
CS150-12CS	CS150-12SS	CS150-12AL	59.13		60.33	
CS200-1CS	CS200-1SS	CS200-1AL	2"	55.96	57.15	
CS200-2CS	CS200-2SS	CS200-2AL		57.55	58.74	
CS200-3CS	CS200-3SS	CS200-3AL		59.13	60.33	
CS200-4CS	CS200-4SS	CS200-4AL		60.72	61.91	
CS200-5CS	CS200-5SS	CS200-5AL		62.31	63.50	
CS200-6CS	CS200-6SS	CS200-6AL		63.90	65.09	
CS200-7CS	CS200-7SS	CS200-7AL		65.48	66.68	
CS200-8CS	CS200-8SS	CS200-8AL		67.07	68.26	
CS200-9CS	CS200-9SS	CS200-9AL		68.66	69.85	
CS200-10CS	CS200-10SS	CS200-10AL		70.25	71.44	
CS200-11CS	CS200-11SS	CS200-11AL		71.83	73.03	
CS200-12CS	CS200-12SS	CS200-12AL		73.42	74.61	
CS300-1CS	CS300-1SS	CS300-1AL	3"	81.36	82.55	
CS300-2CS	CS300-2SS	CS300-2AL		82.95	84.14	
CS300-3CS	CS300-3SS	CS300-3AL		84.53	85.73	
CS300-4CS	CS300-4SS	CS300-4AL		86.12	87.31	
CS300-5CS	CS300-5SS	CS300-5AL		87.71	88.90	
CS300-6CS	CS300-6SS	CS300-6AL		89.30	90.49	
CS300-7CS	CS300-7SS	CS300-7AL		90.88	92.08	
CS300-8CS	CS300-8SS	CS300-8AL		92.47	93.66	
CS300-9CS	CS300-9SS	CS300-9AL		94.06	95.25	
CS300-10CS	CS300-10SS	CS300-10AL		95.65	96.84	
CS300-11CS	CS300-11SS	CS300-11AL		97.23	98.43	
CS300-12CS	CS300-12SS	CS300-12AL		98.82	100.01	
CS300-13CS	CS300-13SS	CS300-13AL		100.41	101.60	
CS300-14CS	CS300-14SS	CS300-14AL		102.00	103.19	
CS300-15CS	CS300-15SS	CS300-15AL		103.58	104.78	
CS300-16CS	CS300-16SS	CS300-16AL	105.17	106.36		
CS400-1CS	CS400-1SS	CS400-1AL	4"	106.76	107.95	
CS400-2CS	CS400-2SS	CS400-2AL		108.35	109.54	
CS400-3CS	CS400-3SS	CS400-3AL		109.93	111.13	
CS400-4CS	CS400-4SS	CS400-4AL		111.52	112.71	
CS400-5CS	CS400-5SS	CS400-5AL		113.11	114.30	
CS400-6CS	CS400-6SS	CS400-6AL		114.70	115.89	
CS400-7CS	CS400-7SS	CS400-7AL		116.28	117.48	
CS400-8CS	CS400-8SS	CS400-8AL		117.87	119.06	
CS400-9CS	CS400-9SS	CS400-9AL		119.46	120.65	
CS400-10CS	CS400-10SS	CS400-10AL		121.05	122.24	
CS400-11CS	CS400-11SS	CS400-11AL		122.63	123.83	
CS400-12CS	CS400-12SS	CS400-12AL		124.22	125.41	
CS400-13CS	CS400-13SS	CS400-13AL	125.81	127.00		
CS400-14CS	CS400-14SS	CS400-14AL	127.40	128.59		
CS400-15CS	CS400-15SS	CS400-15AL	128.98	130.18		
CS400-16CS	CS400-16SS	CS400-16AL	130.57	131.76		
CS600-1CS	CS600-1SS	CS600-1AL	6"	160.73	163.51	
CS600-2CS	CS600-2SS	CS600-2AL		163.91	166.69	
CS600-3CS	CS600-3SS	CS600-3AL		167.08	169.86	
CS600-4CS	CS600-4SS	CS600-4AL		170.26	173.04	
CS600-5CS	CS600-5SS	CS600-5AL		173.43	176.39	
CS600-6CS	CS600-6SS	CS600-6AL		176.61	179.39	
CS600-7CS	CS600-7SS	CS600-7AL		179.78	182.56	
CS600-8CS	CS600-8SS	CS600-8AL		182.96	185.74	
CS600-9CS	CS600-9SS	CS600-9AL		186.13	188.91	

SAFETY ALERT

Only use the crimp style shanks with the crimp style sleeves and ferrules.

Due to differences in dimensions and tolerances for safety reasons, do not interchange other manufacturer's products with Dixon products.

DIN Specification Cam & Groove BS EN 14420-7:2004



CAM COUPLINGS SMOOTH TAIL WITH COLLAR		
PART NO.	SIZE	MATERIAL
100CSSDIN	DN25	Stainless Steel
150CSSDIN	DN40	Stainless Steel
200CSSDIN	DN50	Stainless Steel
100ESSDIN	DN25	Stainless Steel
150ESSDIN	DN40	Stainless Steel
200ESSDIN	DN50	Stainless Steel
100CPPDIN	DN25	Polypropylene
200CPPDIN	DN50	Polypropylene
100EPPDIN	DN25	Polypropylene
200EPPDIN	DN50	Polypropylene

B

Couplings and Adapters are also available in brass and aluminium. Price on application.

CAM COUPLINGS TO BS EN 14420



PART NO.	SIZE	MATERIAL
75DSSDIN	DN20	Stainless Steel
100DSSDIN	DN25	Stainless Steel
125DSSDIN	DN32	Stainless Steel
150DSSDIN	DN40	Stainless Steel
200DSSDIN	DN50	Stainless Steel
250DSSDIN	DN65	Stainless Steel
300DSSDIN	DN80	Stainless Steel
400DSSDIN	DN100	Stainless Steel
75ASSDIN	DN20	Stainless Steel
100ASSDIN	DN25	Stainless Steel
125ASSDIN	DN32	Stainless Steel
150ASSDIN	DN40	Stainless Steel
200ASSDIN	DN50	Stainless Steel
250ASSDIN	DN65	Stainless Steel
300ASSDIN	DN80	Stainless Steel
400ASSDIN	DN100	Stainless Steel

Couplings and Adapters are also available in brass and aluminium. Price on application.
All female threads are BSP parallel.

BS EN 14420 "EZ BOSS-LOCK"



PART NO.	SIZE	MATERIAL
RD100 DIN EZ	DN25	Stainless Steel
RD150 DIN EZ	DN40	Stainless Steel
RD200 DIN EZ	DN50	Stainless Steel
RD300 DIN EZ	DN80	Stainless Steel
RD400 DIN EZ	DN100	Stainless Steel

Available to special order only. Minimum quantities may apply.

High Pressure Couplings and Adapters For Snow Cannon Applications

B



2" (DN50) COUPLER FOR SAFETY CLAMP

PART NO.	MAX. WORKING PRESSURE	MATERIAL
HPCG50SC	60 Bar	316 / 1.4401 / Z6CND17.11



2" (DN50) COUPLER FOR CRIMP FERRULE

PART NO.	MAX. WORKING PRESSURE	MATERIAL
HPCG50CF	60 Bar	316 / 1.4401 / Z6CND17.11

2" (DN50) COUPLER FOR WIRE WHIP

PART NO.	MAX. WORKING PRESSURE	MATERIAL
HPCG50W	60 Bar	316 / 1.4401 / Z6CND17.11



2" (DN50) COUPLER x BSP PL. FEMALE THREAD

PART NO.	MAX. WORKING PRESSURE	MATERIAL
HPCG50BSPF	60 Bar	316 / 1.4401 / Z6CND17.11



2" (DN50) ADAPTER WITH TAIL FOR SAFETY CLAMP

PART NO.	MAX. WORKING PRESSURE	MATERIAL
HPA50SC	60 Bar	316 / 1.4401 / Z6CND17.11



2" (DN50) ADAPTER WITH TAIL FOR CRIMP FERRULE

PART NO.	MAX. WORKING PRESSURE	MATERIAL
HPA50CF	60 Bar	316 / 1.4401 / Z6CND17.11

2" (DN50) ADAPTER WITH TAIL FOR WIRE WHIP

PART NO.	MAX. WORKING PRESSURE	MATERIAL
HPA50W	60 Bar	316 / 1.4401 / Z6CND17.11



2" (DN50) ADAPTER x BSP PL. FEMALE THREAD

PART NO.	MAX. WORKING PRESSURE	MATERIAL
HPA50BSPF	60 Bar	316 / 1.4401 / Z6CND17.11



2.5" (DN65) X 2" (DN50) BSP PL. FEMALE THREAD COUPLER

PART NO.	MAX. WORKING PRESSURE	MATERIAL
HPCG65BSPF	100 Bar	316 / 1.4401 / Z6CND17.11

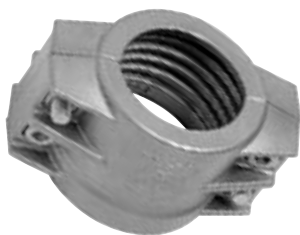

2" (DN50) SAFETY CLAMP

PART NO.	MAX. WORKING PRESSURE	MATERIAL
HPSC50	60 Bar	316 / 1.4401 / Z6CND17.11

B



2" (DN50) HOLEDALL, CRIMP FERRULE

PART NO.	MAX. WORKING PRESSURE	MATERIAL
HPH50CF	60 Bar	ASTM A106 / DIN 2448 / 1629 ST52.0



2" (DN50) x BSP PI. MALE THREAD HOLEDALL®, IX STEM

PART NO.	MAX. WORKING PRESSURE	MATERIAL
HPH50IXS	60 Bar	316L / 1.4404 / Z2CND17.12

Note: IX = Internal Expansion.



2" (DN50) HOLEDALL, IX FERRULE (PLASTIC)

PART NO.	MAX. WORKING PRESSURE	MATERIAL
HPH50IXFP	60 Bar	Cast Nylon

Note: IX = Internal Expansion.



2" (DN50) HOLEDALL, IX FERRULE (CARBON STEEL)

PART NO.	MAX. WORKING PRESSURE	MATERIAL
HPH50IXFC	60 Bar	ASTM A106 / DIN 2448 / 1629 ST52.0

Note: IX = Internal Expansion.

Dry Mates

Sizes: 1", 1 1/2" and 2" (Female NPT & BSP PI Thread)

Material: 316 Stainless Steel construction, Viton Seals.
100% PTFE Ball Seals

Flow: 1" Dry-Mate, 1" Full Port
1 1/2" Dry-Mate, 1 1/2" Full Port
2" Dry-Mate, 1 1/2" Standard Port

Details/Specification:

• **Built in safety features:**

The two Dry-Mate halves couple together with cam arms, the most recognised and proven fluid connection available. Two interlocking handles make opening and closing easy. No guessing involved

• **Built in safety features:**

When liquid is flowing, Dry-Mate halves cannot be uncoupled without turning handles to closed position. When Dry-Mate handles are apart, handles cannot be turned to open position

Prevents accidental spillage and exposure to personnel.



"DRY-MATE" - MALE	
PART NO.	SIZE
DM100ABSS	1"
DM150ABSS	1 1/2"
DM200ABSS	2"

"DRY-MATE" - FEMALE	
PART NO.	SIZE
DM100DBSS	1"
DM150DBSS	1 1/2"
DM200DBSS	2"



Valves fitted with Viton seals. For other optional seal materials, please contact our sales office.

Seals

B

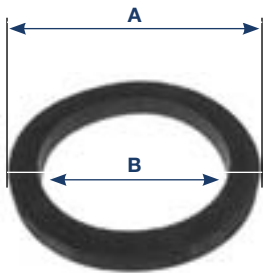

CAM AND GROOVE SEAL DIMENSIONS			
PART NO.	SIZE	DIMENSION A O.D	DIMENSION B I.D
50-G	1/2**	26.19	17.44
75-G	3/4"	34.92	22.22
100-G	1"	39.68	26.98
125-G	1 1/4"	49.19	34.51
150-G	1 1/2"	55.54	41.27
200-G	2"	66.67	50.80
250-G	2 1/2"	79.37	60.32
300-G	3"	94.45	76.20
400-G	4"	124.82	101.60
500-G	5"	150.81	123.82
600-G	6"	177.38	152.40
800-G	8**	236.53	206.37

The ID's of the PTFE Envelope gaskets and the PTFE Accordion gaskets are 1.59mm smaller than the ID's for the Elastomeric gaskets shown above.

*No interchange standard exists for the 1/2" and 8" fittings. Generally these sizes do not interchange with other manufacturers products. As such, the gaskets in these sizes are not suitable for use in other manufacturers couplings.

CAM AND GROOVE SEAL COLOUR CODES

GASKET CODE	GASKET MATERIAL	MATERIAL COLOUR	COLOUR CODE STRIPES
-BU	Buna N (standard in all metal fittings)	Black	1 Blue
-VI	Viton	Black	1 Yellow
-THK	Extra Thick Buna	Black	2 Blue
-EPR	Ethylene Propylene	Black	1 White
-NE	Neoprene	Black	1 Red
-WNE	White Neoprene - FDA approved material	White	None
-WB	White Buna N - FDA approved material	White	Blue
-SIL	Silicone	Red	None
-TF	PTFE (TFE) Envelope with Buna N Filler	White/Black	1 Blue
-TFVI	PTFE (TFE) Envelope with Viton Filler	White/Black	1 Yellow
-TFWB	PTFE (TFE) Envelope with White Buna N Filler - FDA approved material	White/Black	Blue
-TFEP	PTFE (TFE) Envelope with Ethylene Propylene Filler	White/Black	1 White Stripe
-TES	PTFE (FEP) Encapsulated Silicone Core - FDA approved material	Translucent/Red	None
-TEV	PTFE (FEP) Encapsulated Viton Core	Translucent/Black	None
-TFACC	PTFE (TFE) Accordion - FDA approved material	White	None
-HYP	Hypalon	Green	None

Since other manufacturers coding systems vary, this chart should not be used as a reference in identifying gaskets of unknown origin.

CAM AND GROOVE SEALS



PART NO.	SIZE	MATERIAL
50-G-BU	1/2"	Buna-N
75-G-BU	3/4"	Buna-N
100-G-BU	1"	Buna-N
125-G-BU	1 1/4"	Buna-N
150-G-BU	1 1/2"	Buna-N
200-G-BU	2"	Buna-N
250-G-BU	2 1/2"	Buna-N
300-G-BU	3"	Buna-N
400-G-BU	4"	Buna-N
500-G-BU	5"	Buna-N
600-G-BU	6"	Buna-N
100-G-THK	1"	Extra Thick Buna-N
125-G-THK	1 1/4"	Extra Thick Buna-N
150-G-THK	1 1/2"	Extra Thick Buna-N
200-G-THK	2"	Extra Thick Buna-N
250-G-THK	2 1/2"	Extra Thick Buna-N
300-G-THK	3"	Extra Thick Buna-N
400-G-THK	4"	Extra Thick Buna-N
50-G-VI	1/2"	Viton-A
75-G-VI	3/4"	Viton-A
100-G-VI	1"	Viton-A
125-G-VI	1 1/4"	Viton-A
150-G-VI	1 1/2"	Viton-A
200-G-VI	2"	Viton-A
250-G-VI	2 1/2"	Viton-A
300-G-VI	3"	Viton-A
400-G-VI	4"	Viton-A
500-G-VI	5"	Viton-A
75-G-EPR	3/4"	Ethylene Propylene
100-G-EPR	1"	Ethylene Propylene
125-G-EPR	1 1/4"	Ethylene Propylene
150-G-EPR	1 1/2"	Ethylene Propylene
200-G-EPR	2"	Ethylene Propylene
250-G-EPR	2 1/2"	Ethylene Propylene
300-G-EPR	3"	Ethylene Propylene
400-G-EPR	4"	Ethylene Propylene
75-G-NE	3/4"	Neoprene
100-G-NE	1"	Neoprene
125-G-NE	1 1/4"	Neoprene
150-G-NE	1 1/2"	Neoprene
200-G-NE	2"	Neoprene
250-G-NE	2 1/2"	Neoprene
300-G-NE	3"	Neoprene
400-G-NE	4"	Neoprene
150-G-WNE	1 1/2"	White Neoprene*
200-G-WNE	2"	White Neoprene*
300-G-WNE	3"	White Neoprene*
400-G-WNE	4"	White Neoprene*
600-G-WNE	6"	White Neoprene*
400-G-WB	4"	White Buna-N*
600-G-WB	6"	White Buna-N*
150-G-SIL	1 1/2"	Silicone
200-G-SIL	2"	Silicone
300-G-SIL	3"	Silicone
75-G-HYP	3/4"	Hypalon-CSM
100-G-HYP	1"	Hypalon-CSM
125-G-HYP	1 1/4"	Hypalon-CSM
150-G-HYP	1 1/2"	Hypalon-CSM
200-G-HYP	2"	Hypalon-CSM
250-G-HYP	2 1/2"	Hypalon-CSM
300-G-HYP	3"	Hypalon-CSM
400-G-HYP	4"	Hypalon-CSM

* FDA Approved Materials

B



CAM AND GROOVE SEALS

PART NO.	SIZE	MATERIAL
50-G-TF	1/2"	PTFE Buna Filler
75-G-TF	3/4"	PTFE Buna Filler
100-G-TF	1"	PTFE Buna Filler
125-G-TF	1 1/4"	PTFE Buna Filler
150-G-TF	1 1/2"	PTFE Buna Filler
200-G-TF	2"	PTFE Buna Filler
250-G-TF	2 1/2"	PTFE Buna Filler
300-G-TF	3"	PTFE Buna Filler
400-G-TF	4"	PTFE Buna Filler
600-G-TF	6"	PTFE Buna Filler
50-G-TFVI	1/2"	PTFE Viton Filler
75-G-TFVI	3/4"	PTFE Viton Filler
100-G-TFVI	1"	PTFE Viton Filler
125-G-TFVI	1 1/4"	PTFE Viton Filler
150-G-TFVI	1 1/2"	PTFE Viton Filler
200-G-TFVI	2"	PTFE Viton Filler
250-G-TFVI	2 1/2"	PTFE Viton Filler
300-G-TFVI	3"	PTFE Viton Filler
400-G-TFVI	4"	PTFE Viton Filler
200-G-TFWB	2"	PTFE White Buna Filler*
300-G-TFWB	3"	PTFE White Buna Filler*
400-G-TFWB	4"	PTFE White Buna Filler*
200-G-TFEP	2"	PTFE Ethylene Propylene Filler
300-G-TFEP	3"	PTFE Ethylene Propylene Filler
75-G-TES	3/4"	PTFE Encapsulated Silicone*
100-G-TES	1"	PTFE Encapsulated Silicone*
125-G-TES	1 1/4"	PTFE Encapsulated Silicone*
150-G-TES	1 1/2"	PTFE Encapsulated Silicone*
200-G-TES	2"	PTFE Encapsulated Silicone*
250-G-TES	2 1/2"	PTFE Encapsulated Silicone*
300-G-TES	3"	PTFE Encapsulated Silicone*
400-G-TES	4"	PTFE Encapsulated Silicone*
75-G-TEV	3/4"	PTFE Encapsulated Viton
100-G-TEV	1"	PTFE Encapsulated Viton
125-G-TEV	1 1/4"	PTFE Encapsulated Viton
150-G-TEV	1 1/2"	PTFE Encapsulated Viton
200-G-TEV	2"	PTFE Encapsulated Viton
300-G-TEV	3"	PTFE Encapsulated Viton
400-G-TEV	4"	PTFE Encapsulated Viton
100-G-TFACC	1"	PTFE Accordion**
150-G-TFACC	1 1/2"	PTFE Accordion**
200-G-TFACC	2"	PTFE Accordion**
300-G-TFACC	3"	PTFE Accordion**

*All FDA Approved Materials

**Recommended for use with VISCOUS FLUIDS ONLY

The Torque (Force) required to close the handles on a pair of Cam & Groove fittings will vary according to the gasket chosen. Due to the nature of the PTFE material, the various PTFE gasket designs will require the most torque, increasing as you go from Envelope to Encapsulated type and finally to Accordion type.

B





C

Clamps

Heavy Duty T-Bolt	60
Spiral.....	61
Heavy Duty Double Bolt.....	61
Worm Gear.....	62-64
Hi-Torque	65
Single Bolt.....	66
Aero Seal	67
Pre-formed Band Clamps & Accessories	68-71
- F Series Centre Punch.....	68
- K Series Universal Pre-formed.....	69
- Band & Buckles	70
- Clamp Tools.....	70
Ear Pinch.....	71
Band-It™	72-73
Safety Clamps EN 14420-3:2004	74

C

**FOR A FULL RANGE OF HOSES
TO COMPLEMENT THESE FITTINGS SEE SECTION F**



Heavy Duty T-Bolt Clamps

C



Style TBC - 3/4" wide 300 series stainless steel band, .025" thick. Opens 3/32" above and tightens 7/32" smaller than normal I.D. for a total of 5/16" range. **Alloy steel bolt.** Packed 10 per box.



Style STBC - 3/4" wide 300 series stainless steel band, .025" thick. Opens 3/32" above and tightens 7/32" smaller than nominal I.D. for a total of 5/16" range. **300 series stainless steel bolt.** Packed 10 per box.

T-BOLT CLAMPS				
PART NO.	SIZE	O.D. RANGE (MM)		TORQUE IN/LBS
		FROM	TO	
TBC150	1 1/2"	32.5	40.8	70
TBC175	1 3/4"	38.8	46.8	70
TBC188	1 7/8"	42.6	50.0	70
TBC200	2"	45.2	53.1	70
TBC225	2 1/4"	51.5	59.5	70
TBC238	2 3/8"	54.0	62.7	70
TBC250	2 1/2"	57.9	65.8	70
TBC256	2 9/16"	59.5	67.4	70
TBC263	2 5/8"	61.1	69.0	70
TBC275	2 3/4"	64.2	72.2	70
TBC288	2 7/8"	67.4	75.4	70
TBC300	3"	70.6	78.5	70
TBC312	3 1/8"	73.8	81.7	70
TBC325	3 1/4"	76.9	84.9	70
TBC350	3 1/2"	83.3	91.2	70
TBC375	3 3/4"	89.6	97.6	70
TBC400	4"	96.0	103.9	70
TBC425	4 1/4"	102.3	110.3	70
TBC450	4 1/2"	108.7	116.6	70
TBC475	4 3/4"	115.0	123.0	70
TBC500	5"	121.4	129.3	70
TBC525	5 1/4"	127.7	135.0	70
TBC550	5 1/2"	134.0	142.0	70
TBC575	5 3/4"	140.4	148.4	70
TBC600	6"	146.8	154.7	70
TBC625	6 1/4"	153.0	161.0	70
TBC650	6 1/2"	159.5	167.4	70
TBC675	6 3/4"	165.0	173.0	70
TBC700	7"	172.2	180.0	70
TBC750	7 1/2"	184.0	192.0	70
STBC150	1 1/2"	32.5	40.8	50
STBC175	1 3/4"	38.8	46.8	50
STBC188	1 7/8"	42.6	50.0	50
STBC200	2"	45.2	53.1	50
STBC225	2 1/4"	51.5	59.5	50
STBC238	2 3/8"	54.0	62.7	50
STBC250	2 1/2"	57.9	65.8	50
STBC256	2 9/16"	59.5	67.4	50
STBC263	2 5/8"	61.1	69.0	50
STBC275	2 3/4"	64.2	72.2	50
STBC288	2 7/8"	67.4	75.4	50
STBC300	3"	70.6	78.5	50
STBC312	3 1/8"	73.8	81.7	50
STBC325	3 1/4"	76.9	84.9	50
STBC350	3 1/2"	83.3	91.2	50
STBC375	3 3/4"	89.6	97.6	50
STBC400	4"	96.0	103.9	50
STBC425	4 1/4"	102.3	110.3	50
STBC450	4 1/2"	108.7	116.6	50
STBC475	4 3/4"	115.0	123.0	50
STBC500	5"	121.4	129.3	50
STBC525	5 1/4"	127.7	135.0	50
STBC550	5 1/2"	134.0	142.0	50
STBC575	5 3/4"	140.4	148.4	50
STBC600	6"	146.8	154.7	50
STBC625	6 1/4"	153.0	161.0	50
STBC650	6 1/2"	159.5	167.4	50
STBC675	6 3/4"	165.0	173.0	50
STBC700	7"	172.2	180.0	50
STBC750	7 1/2"	184.0	192.0	50

Spiral Clamps

Right Hand Spiral



SPIRAL CLAMPS - CLOCKWISE WOUND	
PART NO.	SIZE
SC200	2"
SC250	2 1/2"
SC300	3"
SC400	4"
SC500	5"
SC600	6"
SC800	8"
SC1000	10"

Left Hand Spiral



For use on convoluted hose.

SPIRAL CLAMPS - COUNTER CLOCKWISE WOUND	
PART NO.	SIZE
SCCW200	2"
SCCW250	2 1/2"
SCCW300	3"
SCCW400	4"
SCCW500	5"
SCCW600	6"
SCCW800	8"
SCCW1000	10"

Clamps are zinc chromate plated carbon steel. Due to fluctuations in the O.D. of hose, each individual installation must be checked.

Heavy Duty Double Bolt Clamps



A rugged, plated malleable iron two-bolt clamp with machine bolts and hex nuts. Bolt lugs are reinforced to prevent bending out of alignment.

Note: Measure Hose O.D. accurately before ordering clamps

DOUBLE BOLT CLAMPS				
PART NO.	FOR HOSE O.D. (MM)		TORQUE FT/LBS	MATERIAL
	FROM	TO		
J48	28	30	15	Malleable Iron
J49	30	34	21	Malleable Iron
JX49	34	38	21	Malleable Iron
DL14	41	46	45	Malleable Iron
DL20	44	52	27	Malleable Iron
DL24	53	58	27	Malleable Iron
DL32	58	66	45	Malleable Iron
DL275	63	69	40	Malleable Iron
DL306	69	77	60	Malleable Iron
DL328	76	84	60	Malleable Iron
DL350	82	95	60	Malleable Iron
400	88	96	40	
431	96	103	40	Malleable Iron
463	102	108	40	Malleable Iron
525	108	125	60	Malleable Iron
550	114	128	60	Malleable Iron
600	130	144	60	Malleable Iron
639	144	151	60	Malleable Iron
675	151	165	60	Malleable Iron
769	165	192	60	Malleable Iron
818	195	208	125	Malleable Iron
875	210	225	125	Malleable Iron
988	227	239	125	Malleable Iron
1125	252	289	125	Malleable Iron
1275	300	330	125	Malleable Iron
1360	310	355	200	Malleable Iron
1450	335	381	200	Malleable Iron
1700	382	444	200	Malleable Iron

Worm Gear Clamps

Combination 5/16" Hexagon and Screwdriver Slotted Screw.

SAE 300 series stainless steel band and housing with SAE 305 stainless steel screw.



Note: This clamp meets with old Mil Spec WW-C-440B, which has been cancelled, and the new governing spec for hose clamps is SAE J1508. Maximum Recommended Torque 30in. lbs.

*Clamps sold 10 per box.

STYLE HSS - WORM GEAR CLAMP

PART NO.	DIAMETER RANGE (MM)		BAND WIDTH
	FROM	TO	
HSS6	11	20	1/2"
HSS8	13	23	1/2"
HSS10	14	27	1/2"
HSS12	17	32	1/2"
HSS16	21	38	1/2"
HSS20	21	44	1/2"
HSS24	27	51	1/2"
HSS28	33	57	1/2"
HSS32	40	64	1/2"
HSS36	46	70	1/2"
HSS40	52	76	1/2"
HSS44	59	83	1/2"
HSS48	65	89	1/2"
HSS52	71	95	1/2"
HSS56	78	102	1/2"
HSS60	84	108	1/2"
HSS64	90	114	1/2"
HSS72	48	127	1/2"
HSS80	64	140	1/2"
HSS88	80	152	1/2"
HSS96	92	165	1/2"
HSS104	105	176	1/2"
HSS128	143	216	9/16"
HSS152	181	254	9/16"
HSS188	238	311	9/16"
HSS200	257	330	9/16"
HSS212	276	349	9/16"
HSS224	295	368	9/16"
HSS236	314	387	9/16"
HSS248	333	406	9/16"
HSS312	435	508	9/16"



*Boxed quantities only.

STYLE MH - MINIATURE WORM GEAR CLAMP*

PART NO.	DIAMETER RANGE (MM)		BAND WIDTH
	FROM	TO	
MH4	5.6	16	5/16"
MH6	11	20	5/16"
MH8	12.7	23	5/16"
MH10	14	27	5/16"
MH12	17	32	5/16"
MH16	24	38	5/16"
MH20	30	44	5/16"

Miniature with combination 1/4" Hexagon and Screwdriver slotted screw.
 SAE 300 series stainless band and housing
 SAE 1018 case-hardened steel, zinc plated and chromate dip screw.
 Maximum Torque 10in/lbs.



*Boxed quantities only.

STYLE MAH - MINIATURE WORM GEAR CLAMP*			
PART NO.	DIAMETER RANGE (MM)		BAND WIDTH
	FROM	TO	
MAH4	5.6	16	5/16"
MAH6	11	20	5/16"
MAH8	12.7	23	5/16"
MAH10	14	27	5/16"
MAH12	17	32	5/16"
MAH16	24	38	5/16"
MAH20	30	44	5/16"

Miniature all stainless construction with combination 1/4" Hexagon and Screwdriver slotted screw. SAE 300 series stainless band and housing SAE 305 stainless screw. Maximum Torque 10in/lbs.

C



*Boxed quantities only.

LS TYPE - QUICK RELEASE WORM GEAR CLAMP*			
PART NO.	DIAMETER RANGE (MM)		TO
	FROM		
LS48	38	89	
LS56	25	102	
LS72	51	127	
LS88	52	152	
LS96	90	166	
LS104	44	178	
LS128	44	217	
LS152	51	254	
LS188	52	312	

301 Stainless Steel Housing and Band. Plated hardened carbon steel screw.



*Clamps sold 10 per box.

LSS TYPE - QUICK RELEASE WORM GEAR CLAMP*			
PART NO.	DIAMETER RANGE (MM)		TO
	FROM		
LSS48	38	89	
LSS72	51	127	
LSS88	52	152	
LSS104	44	178	
LSS128	44	217	
LSS188	52	312	
LSS216	255	356	
LSS248	254	406	

301 Stainless Steel Housing and Band. With SAE 410 series stainless screw.



WORM GEAR CLAMP - MAKE A CLAMP	
PART NO.	CONTENTS
4000	Retail card: 8 1/2 ft band 3 adj. fasteners, 1 band splice
4001	Kit with 100 ft band 25 adj. fasteners, 10 band splices
4002	Kit with 50 ft band 10 adj. fasteners, 5 band splices
4004	Adj. fastener. Priced per box Shipped 10 fasteners per box
4005	Box with 100 ft band, 10 band splices
4006	Box with 50 ft band, 5 band splices
4007	6 ft demonstrator disc with clamps
4008	Priced per box Shipped 10 band splices per box

WORM GEAR CLAMP - MAKE A CLAMP

This is a maintenance “clamp system” in a box. By simply cutting off a piece of a banding from a continuous roll, you can make any size 301 stainless steel worm-drive clamp from 2” diameter and up. It’s a must for anyone likely to encounter requirements for varying sized large clamps. 1/2” band width. Reusable.

Hi -Torque Clamps



HTM HI-TORQUE CLAMPS			
PART NO.	DIAMETER RANGE (MM)		
	FROM		TO
HTM200	31		54
HTM250	44		68
HTM300	57		79
HTM350	69		92
HTM400	82		104
HTM450	95		117
HTM500	107		130
HTM550	120		142
HTM600	133		155
HTM650	146		168
HTM700	158		181
HTM750	171		193
HTM800	184		206
HTM850	196		219
HTM900	209		231

Withstands more than 4 times the SAE torque requirements for worm-drive clamps. 5/8" wide 302/304 half hard stainless steel band. Eight screw-threads are engaged in the band simultaneously for incredible torquing drive (over 200in. lbs), sealing pressure and vibration resistance.

* All of the above are sold in box quantities of 10 per box.

Recommended torque rating in FT.LBS (for malleable iron and stainless steel clamps only)



HTM HI-TORQUE CLAMPS - EXTENDED RANGE			
PART NO.	DIAMETER RANGE (MM)		
	FROM		TO
HP2	31		66
HP3	53		107
HP4	102		155
HP4	155		231

Withstands more than 4 times the SAE torque requirements for worm-drive clamps. 5/8" wide 302/304 half hard stainless steel band. Eight screw-threads are engaged in the band simultaneously for incredible torquing drive (over 200in. lbs), sealing pressure and vibration resistance.

* All of the above are sold in box quantities of 10 per box.

Recommended torque rating in FT.LBS (for malleable iron and stainless steel clamps only)

Single Bolt Superclamps

C



SINGLE BOLT SUPERCLAMPS			
PART NO.	FOR HOSE O.D. (MM)		TORQUE IN/LBS
	FROM	TO	
SC019	17	19	31
SC022	20	22	31
SC025	23	25	31
SC028	26	28	31
SC031	29	31	53
SC035	32	35	53
SC039	36	39	53
SC043	4	43	53
SC047	44	47	106
SC051	48	51	106
SC055	52	55	106
SC059	56	59	106
SC063	60	63	106
SC067	64	67	106
SC073	68	73	168
SC079	74	79	168
SC085	80	85	168
SC091	86	91	168
SC097	92	97	168
SC103	98	103	168
SC112	104	112	168
SC121	113	121	168
SC130	122	130	168
SC139	131	139	332
SC148	140	148	332
SC161	149	161	332
SC174	162	174	332
SC187	174	187	332
SC200	188	200	332
SC213	201	213	332
SC226	214	226	332
SC239	227	239	332
SC252	240	252	332

*Boxed quantities only.

- Carbon Steel Band CW15 (DIN 1-114 1).
- Finish: Zinc Plated Chromate / Passivated.
- Torque Values are recommended in in/lbs.

Aero Clamps



AERO-SEAL™ CLAMPS 72000 SERIES*				
PART NO.	DIAM. RANGE		DESCRIPTION	TORQUE IN/LBS
	FROM	TO		
10006	11	20	Plated Carbon Steel Screw	50
10008	12	23	Plated Carbon Steel Screw	50
10010	14	27	Plated Carbon Steel Screw	50
10012	17	32	Plated Carbon Steel Screw	50
10016	21	38	Plated Carbon Steel Screw	50
10020	21	49	Plated Carbon Steel Screw	50
10024	27	51	Plated Carbon Steel Screw	50
10028	33	57	Plated Carbon Steel Screw	50
10032	40	64	Plated Carbon Steel Screw	50
10036	46	70	Plated Carbon Steel Screw	50
10040	52	76	Plated Carbon Steel Screw	50
10044	59	83	Plated Carbon Steel Screw	50
10048	65	89	Plated Carbon Steel Screw	50
10052	71	95	Plated Carbon Steel Screw	50
10056	78	102	Plated Carbon Steel Screw	50
10060	84	108	Plated Carbon Steel Screw	50
10064	90	114	Plated Carbon Steel Screw	50
10072	105	127	Plated Carbon Steel Screw	50
10080	117	140	Plated Carbon Steel Screw	50
10088	130	152	Plated Carbon Steel Screw	50
10096	143	165	Plated Carbon Steel Screw	50
100104	155	178	Stainless Steel Screw	50
20006	11	20	Stainless Steel Screw	50
20008	12	23	Stainless Steel Screw	50
20010	14	27	Stainless Steel Screw	50
20012	17	32	Stainless Steel Screw	50
20016	21	38	Stainless Steel Screw	50
20020	21	49	Stainless Steel Screw	50
20024	27	51	Stainless Steel Screw	50
20028	33	57	Stainless Steel Screw	50
20032	40	64	Stainless Steel Screw	50
20036	46	70	Stainless Steel Screw	50
20040	52	76	Stainless Steel Screw	50
20044	59	83	Stainless Steel Screw	50
20048	65	89	Stainless Steel Screw	50
20052	71	95	Stainless Steel Screw	50
20056	78	102	Stainless Steel Screw	50
20060	84	108	Stainless Steel Screw	50
20064	90	114	Stainless Steel Screw	50
20072	105	127	Stainless Steel Screw	50
20080	117	140	Stainless Steel Screw	50
20088	130	152	Stainless Steel Screw	50
20096	143	165	Stainless Steel Screw	50
200104	155	178	Stainless Steel Screw	50

* Boxed quantities only.

- **4-Piece Construction**

Band, saddle housing and screw

- **Full 9/16" Wide Bands**

300-series, stainless steel, with a finished edge to protect hose

- **"Arcial" Band Slots**

Arched on one side for strength, flat on bearing side for strength and smooth action

- **Buttress-Thread Heat Treated Screws**

Flat, non-tapered threads which bear at right angles to band slots on loaded side; won't jump out. Sloping buttress shape enforces unloaded side

- **Clinched Saddle and Housing**

No spot welds to corrode or break. Saddle interlocks into embossed band to form a true concentric circle. There are no lumps, no humps, no excessive pressure points, providing higher sealing pressure with lower torque on the screw.

Heavy-gauge housing is clinched on 4 corners to interlocked saddle, permitting higher torque capabilities than any 3-piece clamp. Also available with safety collared or thumb screw

- **Sold Ten Per Box**



Preformed Band Clamps and Accessories

F SERIES

Centre Punch Clamps

For use with centre punch tools F38, F40 and F100.

Other manufacturer's punch style tools may be used.

C



STYLE F (PRE-FORMED)				
PART NO.	I. D. SIZE (MM)	WIDTH	THICKNESS (INCHES)	MATERIAL
F3	20.6	3/8"	.022"	Galv. Steel
F311	34.9	3/8"	.022"	Galv. Steel
F4	25.4	5/8"	.025"	Galv. Steel
F5	31.7	5/8"	.025"	Galv. Steel
F6	38.1	5/8"	.031"	Galv. Steel
F7	44.4	5/8"	.031"	Galv. Steel
F8	50.8	5/8"	.031"	Galv. Steel
F9	57.1	5/8"	.031"	Galv. Steel
F10	63.5	5/8"	.031"	Galv. Steel
F11	69.8	5/8"	.031"	Galv. Steel
F12	76.2	5/8"	.031"	Galv. Steel
F14	88.9	5/8"	.031"	Galv. Steel
F16	101.6	5/8"	.031"	Galv. Steel
F18	114.3	5/8"	.031"	Galv. Steel
F20	127.0	5/8"	.031"	Galv. Steel
F24	152.4	5/8"	.031"	Galv. Steel
F28	177.8	5/8"	.031"	Galv. Steel
F32	203.0	5/8"	.031"	Galv. Steel
FS3	20.6	3/8"	.020"	Stainless Steel
FS11	34.9	3/8"	.020"	Stainless Steel
FS4	25.4	5/8"	.022"	Stainless Steel
FS5	31.7	5/8"	.022"	Stainless Steel
FS6	38.1	5/8"	.022"	Stainless Steel
FS7	44.4	5/8"	.022"	Stainless Steel
FS8	50.8	5/8"	.022"	Stainless Steel
FS9	57.1	5/8"	.022"	Stainless Steel
FS10	63.5	5/8"	.022"	Stainless Steel
FS11	69.8	5/8"	.022"	Stainless Steel
FS12	76.2	5/8"	.022"	Stainless Steel
FS14	88.9	5/8"	.022"	Stainless Steel
FS16	101.6	5/8"	.022"	Stainless Steel
FS18	114.3	5/8"	.022"	Stainless Steel
FS20	127.0	5/8"	.022"	Stainless Steel
FS24	152.4	5/8"	.022"	Stainless Steel
FS28	177.8	5/8"	.022"	Stainless Steel
FS32	203.0	5/8"	.022"	Stainless Steel

STYLE FO (OPEN END)				
PART NO.	I. D. SIZE (MM)	WIDTH	THICKNESS (INCHES)	MATERIAL
FO3	20.6	3/8"	.022"	Galv. Steel
FO311	34.9	3/8"	.022"	Galv. Steel
F8	50.8	5/8"	.025"	Galv. Steel
F10	63.5	5/8"	.025"	Galv. Steel
FO12	76.2	5/8"	.031"	Galv. Steel
FO14	88.9	5/8"	.031"	Galv. Steel
FO16	101.6	5/8"	.031"	Galv. Steel
FO18	114.3	5/8"	.031"	Galv. Steel
FO20	127.0	5/8"	.031"	Galv. Steel
FO24	152.4	5/8"	.031"	Galv. Steel
FO28	177.8	5/8"	.031"	Galv. Steel
FO32	203.0	5/8"	.031"	Galv. Steel
FO36	228.0	5/8"	.031"	Galv. Steel
FO40	254.0	5/8"	.031"	Galv. Steel
FO48	304.0	5/8"	.031"	Galv. Steel
FO56	355.0	5/8"	.031"	Galv. Steel
FOS3	20.6	3/8"	.020"	Stainless Steel
FOS311	34.9	3/8"	.020"	Stainless Steel
FOS8	50.8	5/8"	.022"	Stainless Steel
FOS10	63.5	5/8"	.022"	Stainless Steel
FOS12	76.2	5/8"	.022"	Stainless Steel
FOS14	88.9	5/8"	.022"	Stainless Steel
FOS16	101.6	5/8"	.022"	Stainless Steel
FOS18	114.3	5/8"	.022"	Stainless Steel
FOS20	127.0	5/8"	.022"	Stainless Steel
FOS24	152.4	5/8"	.022"	Stainless Steel
FOS28	177.8	5/8"	.022"	Stainless Steel
FOS32	203.0	5/8"	.022"	Stainless Steel

*Larger and custom sizes available on request

K SERIES

The Universal Preformed Clamp

Can be centre punched
or rolled over.



*Sold in box quantities only -
Packed 100 per box.

K SERIES CLAMPS				
PART NO.	I. D. SIZE (MM)	WIDTH	THICKNESS (INCHES)	MATERIAL
K3	20.6	3/8"	.025"	Galv. Steel
K311	34.9	3/8"	.025"	Galv. Steel
K4	25.4	5/8"	.030"	Galv. Steel
K5	31.7	5/8"	.030"	Galv. Steel
K6	38.1	5/8"	.030"	Galv. Steel
K7	44.4	5/8"	.030"	Galv. Steel
K8	50.8	5/8"	.030"	Galv. Steel
K9	57.1	5/8"	.030"	Galv. Steel
K10	63.5	5/8"	.030"	Galv. Steel
K11	69.8	5/8"	.030"	Galv. Steel
K12	76.2	5/8"	.030"	Galv. Steel
K14	88.9	5/8"	.030"	Galv. Steel
K16	101.6	5/8"	.030"	Galv. Steel
K18	114.3	5/8"	.030"	Galv. Steel
K20	127.0	5/8"	.030"	Galv. Steel
K24	152.4	5/8"	.030"	Galv. Steel
K28	177.8	5/8"	.030"	Galv. Steel
K32	203.0	5/8"	.030"	Galv. Steel
KS87501	50.8	3/4"	.030"	Galv. Steel
KS97501	57.1	3/4"	.030"	Galv. Steel
KS107501	63.5	3/4"	.030"	Galv. Steel
KS117501	69.8	3/4"	.030"	Galv. Steel
KS127501	76.2	3/4"	.030"	Galv. Steel
KS147501	82.5	3/4"	.030"	Galv. Steel
KS167501	88.9	3/4"	.030"	Galv. Steel
KS187501	95.2	3/4"	.030"	Galv. Steel
KS207501	101.6	3/4"	.030"	Galv. Steel
KS247501	152.4	3/4"	.030"	Galv. Steel
KS287501	177.8	3/4"	.030"	Galv. Steel
KS327501	203.0	3/4"	.030"	Galv. Steel
KS3	20.6	3/8"	.025"	Stainless Steel
KS311	34.9	3/8"	.025"	Stainless Steel
KS4	25.4	5/8"	.030"	Stainless Steel
KS5	31.7	5/8"	.030"	Stainless Steel
KS6	38.1	5/8"	.030"	Stainless Steel
KS7	44.4	5/8"	.030"	Stainless Steel
KS8	50.8	5/8"	.030"	Stainless Steel
KS9	57.1	5/8"	.030"	Stainless Steel
KS10	63.5	5/8"	.030"	Stainless Steel
KS11	69.8	5/8"	.030"	Stainless Steel
KS12	76.2	5/8"	.030"	Stainless Steel
KS14	88.9	5/8"	.030"	Stainless Steel
KS16	101.6	5/8"	.030"	Stainless Steel
KS18	114.3	5/8"	.030"	Stainless Steel
KS20	127.0	5/8"	.030"	Stainless Steel
KS24	152.4	5/8"	.030"	Stainless Steel
KS28	177.8	5/8"	.030"	Stainless Steel
KS32	203.0	5/8"	.030"	Stainless Steel

- 3/4" Clamp must be applied with F-175 hand tool or "Band-it" S100 air tool with S180 Jr. Head
- "Fast-Lok" Tools F1, F40 and F100
- "Super Strap Tools" 51960 (screw action) with 1970 adapter
- "Bandit" S100 Air Tool with S180 Jr. Head
- "Bandit" C-001 Hand Tool with J001 Jr. Adapter
- "Bandit" S350 Air Tool with S260 Jr. Head
- "Bandit" T240 for 3/8" only, T250 for 3/8" and 5/8"
- "Bandit" S38 for 3/8" and 5/8", J-102.
- "Pok-it" 3/8" only
- "Punch-Lok" P1 for 3/8" and 5/8"
- "Punch-Lok" P3 for 3/8" only
- "Punch-Lok" P38 for 3/8" and 5/8"

Band and Buckles

C



STRAPPING - 100 FT. PER BOX			
PART NO.	WIDTH	THICKNESS (INCHES)	MATERIAL
SS375	3/8"	.025	Stainless Steel
SS500	1/2"	.030	Stainless Steel
SS625	5/8"	.030	Stainless Steel
SS750	3/4"	.030	Stainless Steel
SG375	3/8"	.025	Galvanised Steel
SG500	1/2"	.030	Galvanised Steel
SG625	5/8"	.030	Galvanised Steel
SG750	3/4"	.030	Galvanised Steel



BUCKLES				
PART NO.	WIDTH	THICKNESS (INCHES)	BOX QTY	MATERIAL
CS375	3/8"	.025	100	Stainless Steel
CS500	1/2"	.030	100	Stainless Steel
CS625	5/8"	.030	100	Stainless Steel
CS750	3/4"	.030	50	Stainless Steel
CG375	3/8"	.025	100	Galvanised Steel
CG500	1/2"	.030	100	Galvanised Steel
CG625	5/8"	.030	100	Galvanised Steel
CG750	3/4"	.030	50	Galvanised Steel

(Jack Type)



CLAMPING TOOL	
PART NO.	DESCRIPTION
C2	Lightweight, side-entry for band and buckles

(Screw Action)

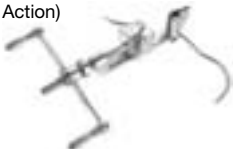

CLAMPING TOOL	
PART NO.	DESCRIPTION
51960	Vice application only for band and buckles



BAND CLAMP HAND TOOL	
PART NO.	APPLICATION
F550	Clamp Cutter
F225	Mallet for punching clamps
51970	Adapter for 51960 for installing pre-formed clamps
F38	Locking Tool. Portable hand tool used to apply punch type 3/8" and 5/8" band clamps
F40	Hand Tool. Intermediate hand tool for 3/8" and 5/8" band clamps
F1	Hand held tool for application of 5/8" band clamps
F175	Hand held tool for application of 3/4" K clamps
F100	Hand held tool for application of 3/8" and 5/8" band clamps



Zinc Plated Carbon Steel.
 1/4" Wide Band x 0.03" thick.
 When ordering Double Ear Clamps, select nominal clamp size nearest to, but always larger than O.D. of material to be clamped after insert has been fitted.

*Sold 100 per bag.

DOUBLE EAR PINCH ON CLAMPS*			
PART NO.	NOMINAL SIZE	INCHES CLOSED	INCHES OPEN
0305	3/16"	.118	.197
0507	1/4"	.197	.276
0709	5/16"	.276	.354
0811	3/8"	.315	.433
0911	7/16"	.354	.433
1113	1/2"	.433	.512
1315	9/16"	.512	.591
1517	19/32"	.591	.669
1518	5/8"	.591	.708
1720	3/4"	.669	.787
1922	13/16"	.748	.866
2023	7/8"	.787	.905
2225	15/16"	.866	.984
2327	1"	.905	1.063
2731	1 1/8"	1.063	1.220
2831	1 3/16"	1.102	1.220
3437	1 7/16"	1.339	1.457
3740	1 1/2"	1.457	1.575



Zinc Plated Carbon Steel.
 1/4" Wide Band x 0.03" thick.

*Sold 100 per bag.

SINGLE EAR PINCH ON CLAMPS			
PART NO.	NOMINAL SIZE	INCHES CLOSED	INCHES OPEN
105	3/8"	.350	.414
113	7/16"	.381	.444
123	15/32"	.394	.486
133	1/2"	.453	.524
140	35/64"	.472	.551
145	9/16"	.496	.571
157	5/8"	.543	.618
170	11/16"	.594	.669
185	23/32"	.618	.728
198	3/4"	.669	.779
210	1 3/16"	.716	.827
226	7/8"	.779	.890
241	15/16"	.839	.949
256	1"	.898	1.008
271	1 1/16"	.945	1.067
286	1 1/8"	1.004	1.126
301	1 3/16"	1.063	1.185
331	1 5/16"	1.181	1.303
346	1 3/8"	1.240	1.362
376	1 15/32"	1.358	1.480
396	1 9/16"	1.437	1.559
410	1 5/8"	1.492	1.614
425	1 11/16"	1.551	1.673
440	1 23/32"	1.610	1.732
455	1 3/4"	1.669	1.791
470	1 13/16"	1.728	1.850
485	1 7/8"	1.787	1.909
500	1 15/16"	1.846	1.968
515	2"	1.905	2.028



OETIKER CLAMP TOOLS FOR PINCH-ON CLAMPS	
PART NO.	DESCRIPTION
1098-0	Standard Jaw Clamp Tool for Pinch-On Clamps
9901	Straight Jaw (Long Handle)
1099	Heavy Duty Clamp Tool with Side Jaws



CLAMP SERVICE KIT			
PART NO.	DESCRIPTION		
SK1098	Plastic box contains all Zinc plated 2-ear clamps		
	15 of part No.0708	15 of part No.1518	12 of part No.1720
	15 of part No.0911		12 of part No.2023
	15 of part No.1113		12 of part No.2225
	15 of part No.1315		12 of part No.2327
			1 pair of Standard Jaw Pincers part No.1098

Band-It Preformed Clamp IT System

Ultra-Lok®

- Quick & easy installation
- 201¼ hard stainless steel
- Superior vibration resistance. Locks under full tension
- Unique lock formed under full tension maximising tightness
- Smooth ID design reduces leak paths
- Double wrapped for additional strength
- Patented lock design from 1½" to 9" available



ULTRA-LOK® PREFORMED CLAMP

PART NO.	MATERIAL	WIDTH		THICKNESS		INSIDE DIAM.		PACKAGE QTY	PACKAGE WEIGHT		
		IN	MM	IN	MM	IN	MM		LBS	KG	
UL2799**	201 SS	1¼" Hard	1½"	12.7	0.030	0.76	1½"	38	100/box	9.1	4.1
UL2839**	201 SS	1¼" Hard	1½"	12.7	0.030	0.76	2"	50	100/box	10.6	4.8
UL2869**	201 SS	1¼" Hard	1½"	12.7	0.030	0.76	2¾"	69	100/box	12.7	5.8
UL2919	201 SS	1¼" Hard	1½"	12.7	0.030	0.76	4"	101	100/box	16.7	7.6
UL2279	201 SS	1¼" Hard	¾"	19.1	0.030	0.76	2"	50	100/box	14.9	6.8
UL2109	201 SS	1¼" Hard	¾"	19.1	0.030	0.76	2¾"	69	50/box	9.2	4.2
UL2119	201 SS	1¼" Hard	¾"	19.1	0.030	0.76	3"	76	50/box	10.4	4.7
UL2129	201 SS	1¼" Hard	¾"	19.1	0.030	0.76	3½"	88	50/box	10.8	4.9
UL2139	201 SS	1¼" Hard	¾"	19.1	0.030	0.76	4"	101	25/box	6.4	2.9
UL2149	201 SS	1¼" Hard	¾"	19.1	0.030	0.76	4½"	114	25/box	7.0	3.2
UL2159	201 SS	1¼" Hard	¾"	19.1	0.030	0.76	5"	127	25/box	7.5	3.4
UL2709	201 SS	1¼" Hard	¾"	19.1	0.030	0.76	5¼"	139	25/box	7.3	3.3
UL2169	201 SS	1¼" Hard	¾"	19.1	0.030	0.76	6"	152	25/box	8.4	3.8
UL2179	201 SS	1¼" Hard	¾"	19.1	0.030	0.76	6½"	165	25/box	10.2	4.6
UL2189	201 SS	1¼" Hard	¾"	19.1	0.030	0.76	7"	177	25/box	9.8	4.4
UL2199	201 SS	1¼" Hard	¾"	19.1	0.030	0.76	8"	203	25/box	11.0	5.0
UL2289	201 SS	1¼" Hard	¾"	19.1	0.030	0.76	9"	228	10/box	5.1	2.31

Junior® Smooth ID

- Quick & easy installation
- 3 material choices
- Vibration resistant lip wrap lock
- Smooth ID design reduces leak path
- Double wrapped for additional strength
- Various widths available



Centre Punch

- Quick & easy installation
- 2 material choices
- Locks using conical punch
- Manufactured with stainless steel buckle for greater strength
- Double wrapped for additional strength
- Various widths available



Band & Buckle

- High strength fastening & clamping
- Wide variety of materials
- Available in various widths & thicknesses



C

UL9010 Ultra-Lok® Electric Tool

- Ultra-Lok® clamps 1/2"* & 3/4" either preformed or Band and Buckle can be applied.
- Locks under full tension.
- Adjustable speed and torque.
- Consistent, repeatable tensioning.
- Ideal for hose clamping.



UL4000 Rechargeable or cordless Ultra-Lok® Tool

- Ultra-Lok® clamps 1/2"* & 3/4" either preformed or Band and Buckle can be applied.
- Designed for portable requirements.
- Consistent repeatable tensioning.
- Locks under full tension.
- Ultra-Lok® clamps can be applied four times faster than conventional clamps.
- Supplied with spare battery and charger with Automatic Tune-Up feature.



ULTRA-LOK® TOOLS				
PART NO.	DESCRIPTION	PACKAGE QUANTITY	PACKAGE WEIGHT	
			LBS	KGS
UL4000 ULTRA-LOK®	18-volt Rechargeable, Portable Tool.	each	17.8	6.7
UL9010 ULTRA-LOK®	110-volt AC, Corded Electric Tool.	each	18.4	8.4
ULK249	Kit; Used to upgrade the tension body of the UL9000 each and the UL9010, includes 3/4" and 1/2" shear plates.	each	0.4	0.2
M09387	1/2" Shear plate for UL4000, upgraded UL9000 and UL9010 to each Convert from 3/4" Ultra-Lok® to 1/2" Ultra-Lok® Clamp Systems.	each	0.1	0.1

For 1/2" Applications, must use M09387 1/2" Shear Plate.

*BAND-IT reserves the right to substitute material with equal or better corrosion resistance and/or mechanical specifications.

Safety Clamps BS EN 14420-3:2004

C



SAFETY CLAMPS		
PART NO.	SIZE (mm)	MATERIAL
SC13X6AL	13 x 6	Aluminium
SC19X6AL	19 x 6	Aluminium
SC25X6AL	25 x 6	Aluminium
SC32X6AL	32 x 6	Aluminium
SC38X6.5AL	38 x 6.5	Aluminium
SC38X8AL	38 x 8	Aluminium
SC38X10AL	38 x 10	Aluminium
SC50X8AL	50 x 8	Aluminium
SC50X10AL	50 x 10	Aluminium
SC63X8AL	63 x 8	Aluminium
SC65X10AL	65 x 10	Aluminium
SC75X7.5AL	75 x 7.5	Aluminium
SC75X10AL	75 x 10	Aluminium
SC100X8AL	100 x 8	Aluminium
SC100X10AL	100 x 10	Aluminium
SC100X12AL	100 x 12	Aluminium
SC150X10AL	150 x 10	Aluminium
SC19X6SS	19 x 6	316 Stainless Steel
SC25X6SS	25 x 6	316 Stainless Steel
SC38X6.5SS	38 x 6.5	316 Stainless Steel
SC38X8SS	38 x 8	316 Stainless Steel
SC50X6SS	50 x 6	316 Stainless Steel
SC50X8SS	50 x 8	316 Stainless Steel
SC50X10SS	50 x 10	316 Stainless Steel
SC63X8SS	63 x 8	316 Stainless Steel
SC65X7SS	65 x 7	316 Stainless Steel
SC75X7.5SS	75 x 7.5	316 Stainless Steel

Note: First number in the part reference denotes the inside diameter of the hose that clamp will suit while the second number denotes the wall thickness.

E.G.: Part SC50X8AL will suit a 50mm I.D. hose with an 8mm wall = 66mm O.D.



D



Fire Products - Dixon Powhatan

Valves.....	78
Fire Department Connections.....	78
Hose	78
Hydrant Adapters.....	79
Hydrant Nozzles.....	79
Hose Couplings.....	79

D



**FOR A FULL RANGE OF HOSES
TO COMPLEMENT THESE FITTINGS SEE SECTION F**



The Right Connection when it comes to fire related products.

Valves

Manufacturer and distributor of fire protection valves

- Hose valves
- Pressure reducing
- Pressure regulating
- Globe valves
- Gate valves
- Ball valves
- Angle valves
- Pressure restricting angle valves
- Wharf hydrants
- UL and FM approved



D

Fire Department Connections

- Single, double, and triple clappers
- Angled and straight bodies
- Polished and/or chromed
- Concealed and reversible
- Sidewalk connections (2, 3, and 4 way)
- Roof connections
- Special threads in stock
- UL and FM approved where required



Hose

- Mill hose, single and double jacket, coupled, uncoupled
- 300#, 400#, 500#, 800# available
- Single and double jackets
- Rack hose
- Booster hose
- Speciality hoses in stock: forestry, UL labeled, MSHA, potable water, urethane covered



Hydrant Adapters

- Brass and aluminium
- Caps and plugs
- Reducers
- Hex, pin and rocker lug, swivels and long handle
- Most threads in stock others available
- Polished and/or chromed
- Spanners for Storz, pin and rocker lug



D



Hydrant Nozzles

- Brass fog
- Heavy duty
- Electrical
- Pow-R-Fog
- Plain tips
- Play pipes
- Rack nozzles
- Garden hose twist
- Thermoplastic
- Monitors
- Aluminium constant and adjustable fog

Hose Couplings

- Brass and aluminium expansion rings
- Forestry rocker lug and forged 1/4 turn forestry
- Booster hose fitting and installation kit
- Storz
- Instantaneous Couplings & adapters
- Suction Hose Couplings





E

Fittings, Gauges & Adapters

Hydraulic Pipe Fittings	82-85
316 Stainless Steel Weld End Pipe Fittings	86
316 Stainless Steel Flanges	87
Smooth Tails BS EN 14420-2	88
Fixed & Swivel Smooth Tails BS EN 14420-2	89
Instrumentation Fittings	90-93
Brass Hose Fittings	93
Brass Crimp Ferrules	94
Ferrule Crimping Tools	95-96
Tuff-Lite & Plastic Fittings	97
Glycerine Filled Pressure Gauges	98

E

**FOR A FULL RANGE OF HOSES
TO COMPLEMENT THESE FITTINGS SEE SECTION F**



Pipe Fittings 150lbs - 316 Stainless Steel

Sizes: 1/8" to 6"

Materials: 316 Stainless Steel

Details:

- Manufactured to the requirements of ASTM A-351
- Basic dimensions and pressure ratings in accordance with ANSI B16.3/150lbs

E



BSPT HEXAGON NIPPLE	
PART NO.	BSPT THREAD
H0.125SHN	1/8"
H0.25SHN	1/4"
H0.37SHN	3/8"
H0.5SHN	1/2"
H0.75SHN	3/4"
H1SHN	1"
H1.25SHN	1 1/4"
H1.5SHN	1 1/2"
H2SHN	2"
H2.5SHN	2 1/2"



BSPT BARREL NIPPLE	
PART NO.	BSPT THREAD
H0.125BNM	1/8"
H0.25SBNM	1/4"
H0.375SBNM	3/8"
H0.5SBNM	1/2"
H0.75SBNM	3/4"
H1SBNM	1"
H1.25SBNM	1 1/4"
H1.5SBNM	1 1/2"
H2SBNM	2"



BSPT WELDING NIPPLE	
PART NO.	BSPT THREAD
H0.125SWNM	1/8"
H0.25SWNM	1/4"
H0.375SWNM	3/8"
H0.5SWNM	1/2"
H0.75SWNM	3/4"
H1SWNM	1"
H1.25SWNM	1 1/4"
H1.5SWNM	1 1/2"
H2SWNM	2"



BSPT CLOSE TAPER NIPPLE	
PART NO.	BSPT THREAD
H0.375SCTN	3/8"
H0.5SCTN	1/2"
H0.75SCTN	3/4"
H1SCTN	1"
H1.25SCTN	1 1/4"
H1.5SCTN	1 1/2"
H2SCTN	2"



BSP PI. ROUND BLANKING CAP	
PART NO.	BSP PI. THREAD
H0.125SRC	1/8"
H0.25SRC	1/4"
H0.375SRC	3/8"
H0.5SRC	1/2"
H0.75SRC	3/4"
H1SRC	1"
H1.25SRC	1 1/4"
H1.5SRC	1 1/2"
H2SRC	2"

E



BSP PI. FEMALE 90° ELBOW	
PART NO.	BSP PI. THREAD
H0.125S9OFF	1/8"
H0.25S9OFF	1/4"
H0.375S9OFF	3/8"
H0.5S9OFF	1/2"
H0.75S9OFF	3/4"
H1S9OFF	1"
H1.25S9OFF	1 1/4"
H1.5S9OFF	1 1/2"
H2S9OFF	2"
H2.5S9OFF	2 1/2"
H3S9OFF	3"



BSP PI. 45° ELBOW FEMALE	
PART NO.	BSP PI. THREAD
H0.125S45FF	1/8"
H0.25S45FF	1/4"
H0.375S45FF	3/8"
H0.5S45FF	1/2"
H0.75S45FF	3/4"
H1S45FF	1"
H1.25S45FF	1 1/4"
H1.5S45FF	1 1/2"
H2S45FF	2"



BSP PI. UNION FEMALE

PART NO.	BSP PI. THREAD
H0.125SUFF	1/8"
H0.25SUFF	1/4"
H0.375SUFF	3/8"
H0.5SUFF	1/2"
H0.75SUFF	3/4"
H1SUFF	1"
H1.25SUFF	1 1/4"
H1.5SUFF	1 1/2"
H2SUFF	2"

E



BSP PI. SCREWED FEMALE SOCKET

PART NO.	BSP PI. THREAD
H0.125SFS	1/8"
H0.25SFS	1/4"
H0.375SFS	3/8"
H0.5SFS	1/2"
H0.75SFS	3/4"
H1SFS	1"
H1.25SFS	1 1/4"
H1.5SFS	1 1/2"
H2SFS	2"
H2.5SFS	2 1/2"
H3SFS	3"



BSP PI. FEMALE HALF SOCKET

PART NO.	BSP PI. THREAD
H0.125SHS	1/8"
H0.25SHS	1/4"
H0.375SHS	3/8"
H0.5SHS	1/2"
H0.75SHS	3/4"
H1SHS	1"
H1.25SHS	1 1/4"
H1.5SHS	1 1/2"
H2SHS	2"
H2.5SHS	2 1/2"
H3SHS	3"



BSPT HEXAGON HEADED BLANK PLUG

PART NO.	BSPT THREAD
H0.125SHPH	1/8"
H0.25SHPH	1/4"
H0.375SHPH	3/8"
H0.5SHPH	1/2"
H0.75SHPH	3/4"
H1SHPH	1"
H1.25SHPH	1 1/4"
H1.5SHPH	1 1/2"
H2SHPH	2"
H2.5SHPH	2 1/2"
H3SHPH	3"



BSPT SQUARE BLANK PLUG	
PART NO.	BSPT THREAD
H0.125SHPS	1/8"
H0.25SHPS	1/4"
H0.375SHPS	3/8"
H0.5SHPS	1/2"
H0.75SHPS	3/4"
H1SHPS	1"
H1.25SHPS	1 1/4"
H1.5SHPS	1 1/2"
H2SHPS	2"
H2.5SHPS	2 1/2"
H3SHPS	3"



BSP PI. HEXAGON LOCKNUT	
PART NO.	BSP PI. THREAD
H0.125SLN	1/8"
H0.25SLN	1/4"
H0.375SLN	3/8"
H0.5SLN	1/2"
H0.75SLN	3/4"
H1SLN	1"
H1.25SLN	1 1/4"
H1.5SLN	1 1/2"
H2SLN	2"
H2.5SLN	2 1/2"
H3SLN	3"

E

316 Stainless Steel Weld End Pipe Fittings

Sizes: 3/4" to 6"

Materials: 316 Stainless Steel

Details:

- All have a schedule 10 wall thickness and are suitable for welding to pipe or to corrugated metal hose

E



BUTT WELD 90° ELBOW (SCHEDULE 10)

PART NO.	NOMINAL PIPE SIZE
H0.75S90	3/4"
H1S90	1"
H1.25S90	1 1/4"
H1.55S90	1 1/2"
H2S90	2"
H2.5S90	2 1/2"
H3S90	3"
H4S90	4"
H5S90	5"
H6S90	6"



BUTT WELD 45° ELBOW (SCHEDULE 10)

PART NO.	NOMINAL PIPE SIZE
H0.75S45	3/4"
H1S45	1"
H1.25S45	1 1/4"
H1.5S45	1 1/2"
H2S45	2"
H2.5S45	2 1/2"
H3S45	3"
H4S45	4"
H5S45	5"
H6S45	6"



BUTT WELD TYPE A STUB END (SCHEDULE 10)

PART NO.	NOMINAL PIPE SIZE
H0.75SSE	3/4"
H1SSE	1"
H1.25SSE	1 1/4"
H1.5SSE	1 1/2"
H2SSE	2"
H2.5SSE	2 1/2"
H3SSE	3"
H4SSE	4"
H5SSE	5"
H6SSE	6"

316 Stainless Steel Flanges



ASA 150 RAISED FACE SLIP ON FLANGE	
PART NO.	NOMINAL PIPE SIZE
0.5SASA	1/2"
0.75SASA	3/4"
1SASA	1"
1.25SASA	1 1/4"
1.5SASA	1 1/2"
2SASA	2"
2.5SASA	2 1/2"
3SASA	3"
4SASA	4"
6SASA	6"

E



PN16/3 RAISED FACE SLIP ON FLANGE	
PART NO.	NOMINAL PIPE SIZE
0.5SNP16	1/2"
0.75SNP16	3/4"
1SNP16	1"
1.25SNP16	1 1/4"
1.5SNP16	1 1/2"
2SNP16	2"
2.5SNP16	2 1/2"
3SNP16	3"
4SNP16	4"
6SNP16	6"

- ASA/150 Flanges are raised face slip-on type and are suitable for working pressure of 10 bar (150 psi)
- PN16/3 Flanges are raised face slip-on type and are suitable for a working pressure of 16 Bar (225 psi)

Smooth Tails BS EN 14420-2:2004 (Hose side of Stem) BS EN 14420-5:2004 (Threaded Connection)



E

SMOOTH TAIL COUPLINGS WITH COLLAR - FEMALE

PART NO.	HOSE TAIL (mm)	BSPP THREAD	MATERIAL
SF19/SS	19	3/4"	Stainless Steel
SF25/SS	25	1"	Stainless Steel
SF32/SS	32	1 1/4"	Stainless Steel
SF38/SS	38	1 1/2"	Stainless Steel
SF50/SS	50	2"	Stainless Steel
SF65/SS	65	2 1/2"	Stainless Steel
SF75/SS	75	3"	Stainless Steel
SF100/SS	100	4"	Stainless Steel
SF19/BR	19	3/4"	Brass
SF19/BR	25	1"	Brass
SF19/BR	32	1 1/4"	Brass
SF19/BR	38	1 1/2"	Brass
SF19/BR	50	2"	Brass
SF19/BR	65	2 1/2"	Brass
SF19/BR	75	3"	Brass
SF19/BR	100	4"	Brass

For EN 14420-3: 2004 Safety Clamps see page 74



SMOOTH TAIL COUPLINGS WITH COLLAR - MALE

PART NO.	HOSE TAIL (mm)	BSPP THREAD	MATERIAL
SM19/SS	19	3/4"	Stainless Steel
SM25/SS	25	1"	Stainless Steel
SM32/SS	32	1 1/4"	Stainless Steel
SM38/SS	38	1 1/2"	Stainless Steel
SM50/SS	50	2"	Stainless Steel
SM65/SS	65	2 1/2"	Stainless Steel
SM75/SS	75	3"	Stainless Steel
SM100/SS	100	4"	Stainless Steel
SM19/BR	19	3/4"	Brass
SM19/BR	25	1"	Brass
SM19/BR	32	1 1/4"	Brass
SM19/BR	38	1 1/2"	Brass
SM19/BR	50	2"	Brass
SM19/BR	65	2 1/2"	Brass
SM19/BR	75	3"	Brass
SM19/BR	100	4"	Brass

For EN 14420-3: 2004 Safety Clamps see page 74

Fixed & Swivel Flanged Smooth Tails BS EN 14420-2:2004 (Hose side of Stem) BS EN 14420-2:2004 (Flange Connection)



FIXED FLANGED HOSE SPIGOTS X TAIL

PART NO.	SIZE	MATERIAL
FF25/CS	DN25	Carbon Steel
FF32/CS	DN32	Carbon Steel
FF40/CS	DN40	Carbon Steel
FF50/CS	DN50	Carbon Steel
FF65/CS	DN65	Carbon Steel
FF80/CS	DN80	Carbon Steel
FF100/CS	DN100	Carbon Steel
FF25/SS	DN25	Stainless Steel
FF32/SS	DN32	Stainless Steel
FF40/SS	DN40	Stainless Steel
FF50/SS	DN50	Stainless Steel
FF65/SS	DN65	Stainless Steel
FF80/SS	DN80	Stainless Steel
FF100/SS	DN100	Stainless Steel

These flanges have PN16 PCD drilling, other flanges including specials are available upon request. Please note: PN10 and PN16 dimensions are the same up to DN150. Stainless steel units are produced from 316. Carbon steel are zinc plated for protection. This range of flanged spigots come complete with a smooth hose tail and retaining collar suitable for use with our range of safety clamps.

E

SWIVEL FLANGED HOSE SPIGOTS X TAIL



PART NO.	SIZE	MATERIAL
FS25/CS	DN25	Carbon Steel
FS32/CS	DN32	Carbon Steel
FS40/CS	DN40	Carbon Steel
FS50/CS	DN50	Carbon Steel
FS65/CS	DN65	Carbon Steel
FS80/CS	DN80	Carbon Steel
FS100/CS	DN100	Carbon Steel
FS125/CS	DN125	Carbon Steel
FS150/CS	DN150	Carbon Steel
FS200/CS	DN200	Carbon Steel
FS25/SS	DN25	Stainless Steel
FS32/SS	DN32	Stainless Steel
FS40/SS	DN40	Stainless Steel
FS50/SS	DN50	Stainless Steel
FS65/SS	DN65	Stainless Steel
FS80/SS	DN80	Stainless Steel
FS100/SS	DN100	Stainless Steel

These flanges have PN16 PCD drilling, other flanges including specials are available upon request. Please note: PN10 and PN16 dimensions are the same up to DN150. Stainless steel units are produced from 316. Carbon steel are zinc plated for protection. This range of flanged spigots come complete with a smooth hose tail and retaining collar suitable for use with our range of safety clamps.

Instrumentation Fittings

Applications: High pressure. High temperature. Nitrogen .Helium Flammable gases. Hydraulic gases. Corrosive media.

Instrumentation fittings come completely assembled.

- Installation Instructions:**
1. Cut tubing squarely and clean tube end thoroughly to remove burrs.
 2. Insert the tubing into the assembly making sure the tubing seats firm against the shoulder of the body and the nut is finger tight.
 3. Tighten the nut with a wrench 1¹/₄ turns, while holding the body with a second wrench.

- Features:**
- Fully interchangeable with Swagelok® and Parker A-Lok® fittings
 - Double collet (ferrule) swaging action
 - Two positive seal points
 - ASTM material construction

Material: • 316 stainless steel temperature ratings: **-198°C to 648°C** (-325°F to 1200°F)

Pressure Ratings: • **See chart below.** Ratings listed are for reference only.

- Safety Guidelines:**
- Never connect, disconnect or remake a fitting with pressure in the system.
 - Make sure all the fittings are properly installed.
 - It is not recommended to go beyond the pressure rating of the tubing. Elongation could occur in the tubing, shrinking the wall thickness and cause potential harm.
 - For proper sealing it is recommended that the tubing and fittings be of like material.
 - Always use proper thread lubricant and sealants on tapered pipe threads.
 - Never bleed a system by loosening a fitting.

SUGGESTED WORKING PRESSURES (PSI)

WALL THK. (INCH)	.028	.035	.049	.065	.083	.095	.109
1/4"	4,000	5,100	7,500	10,100	-	-	-
3/8"	-	3,300	4,700	6,600	-	-	-
1/2"	-	2,600	3,700	5,000	6,600	-	-
5/8"	-	-	2,900	3,900	5,200	6,000	-
3/4"	-	-	2,400	3,200	4,200	4,900	5,700

MALE CONNECTORS

PART #	TUBE OD	MALE NTP	INTERCHANGES	PKG QTY
4-DMC-2	1/4"	1/8"-27	400-1-2	10
4-DMC-4	1/4"	1/4"-18	400-1-4	10
4-DMC-6	1/4"	3/8"-18	400-1-6	10
4-DMC-8	1/4"	1/2"-14	400-1-8	10
6-DMC-4	3/8"	1/4"-18	600-1-4	10
6-DMC-6	3/8"	3/8"-18	600-1-6	10
6-DMC-8	3/8"	1/2"-14	600-1-8	10
8-DMC-4	1/2"	1/4"-18	810-1-4	10
8-DMC-6	1/2"	3/8"-18	810-1-6	10
8-DMC-8	1/2"	1/2"-14	810-1-8	10
10-DMC-8	5/8"	1/2"-14	1010-1-8	10
12-DMC-8	3/8"	1/2"-14	1210-1-8	10
12-DMC-12	3/8"	3/4"	1210-1-12	10





FEMALE CONNECTORS

PART #	TUBE OD	MALE NTP	INTERCHANGES	PKG QTY
4-DFC-2	1/4"	1/8"-27	400-7-2	10
4-DFC-4	1/4"	1/4"-18	400-7-4	10
6-DFC-4	3/8"	1/4"-18	600-7-4	10
6-DFC-8	3/8"	1/2"-14	600-7-8	10
8-DFC-8	1/2"	1/2"-14	810-7-8	10



MALE ELBOWS

PART #	TUBE OD	MALE NTP	INTERCHANGES	PKG QTY
4-DME-2	1/4"	1/8"-27	400-2-2	10
4-DME-4	1/4"	1/4"-18	400-3-4	10
6-DME-4	3/8"	1/4"-18	600-2-4	10
6-DME-6	3/8"	3/8"-18	600-2-6	10
8-DME-8	1/2"	1/2"-14	810-2-8	10
12-DME-8	3/4"	1/2"-14	1210-2-8	10
12-DME-12	3/4"	3/4"	1210-2-12	10

E



UNION TEES

PART #	TUBE OD	INTERCHANGES	PKG QTY
4-DTTT-4	1/4"	400-3	10
6-DTTT-6	3/8"	600-3	10
8-DTTT-8	1/2"	810-3	10



UNIONS

PART #	TUBE OD	INTERCHANGES	PKG QTY
4-DU	1/4" x 1/4"	400-6	10
6-DU-4	3/8" x 1/4"	600-6-4	10
6-DU	3/8" x 3/8"	600-6	10
8-DU	1/2" x 1/2"	810-6	10



BULKHEAD UNIONS

PART #	TUBE OD	INTERCHANGES	PKG QTY
4-DBHU-4	1/4"	400-61	10
6-DBHU-6	3/8"	600-61	10
8-DBHU-8	1/2"	810-61	10



FRONT FERRULES

PART #	TUBE OD	INTERCHANGES	PKG QTY
DFC-4	1/4"	403-1	10
DFC-6	3/8"	603-1	10
DFC-8	1/2"	813-1	10



REAR FERRULES			
PART #	TUBE OD	INTERCHANGES	PKG QTY
DRC-4	1/4"	404-1	10
DRC-6	3/8"	604-1	10
DRC-8	1/2"	814-1	10



FERRULE SETS			
PART #	TUBE OD	INTERCHANGES	PKG QTY
DCSET-4-10	1/4"	400SET	10
DCSET-6-10	3/8"	600SET	10
DCSET-8-10	1/2"	800SET	10

E



NUTS			
PART #	TUBE OD	INTERCHANGES	PKG QTY
DN-4	1/4"	402-1	10
DN-6	3/8"	602-1	10
DN-8	1/2"	812-1	10



UNION ELBOWS			
PART #	TUBE OD	INTERCHANGES	PKG QTY
4-DELU-4	1/4"	400-9	10
6-DELU-6	3/8"	600-9	10
8-DELU-8	1/2"	810-93	10



REDUCERS			
PART #	TUBE OD	INTERCHANGES	PKG QTY
4-DRATT-2	1/4" x 1/8"	400-R-2	10
6-DRATT-4	3/8" x 1/4"	600-R-4	10
6-DRATT-8	3/8" x 1/2"	600-R-8	10
8-DRATT-12	1/2" x 3/4"	810-R-12	10
12-DRATT-8	3/4" x 1/2"	1210-R-8	10



FEMALE ELBOWS				
PART #	TUBE OD	FEMALE NTP	INTERCHANGES	PKG QTY
4-DFE-4	1/4"	1/4"-18	400-8-2	10
6-DFE-6	3/8"	1/4"-18	600-8-4	10
8-DFE-8	1/2"	1/2"-14	810-8-8	10



MALE BRANCH TEE				
PART #	TUBE OD	FEMALE NTP	INTERCHANGES	PKG QTY
4-DTTM-4	1/4"	1/4"-18	400-3-4TTM	10



MALE RUN TEES				
PART #	TUBE OD	FEMALE NTP	INTERCHANGES	PKG QTY
4-DTMT-4	1/4"	1/4"-18	400-3-4TMT	10
6-DTMT-4	3/8"	1/4"-18	600-3TMT	10



CAPS			
PART #	TUBE OD	INTERCHANGES	PKG QTY
4-DCAP	1/4"	400-C	10
6-DCAP	3/8"	600-C	10
8-DCAP	1/2"	810-C	10



PLUGS			
PART #	TUBE OD	INTERCHANGES	PKG QTY
4-DFPLUG	1/4"	400-P	10
6-DFPLUG	3/8"	600-P	10
8-DFPLUG	1/2"	810-P	10

E

Brass Hose Fittings



MALE INSERTS NPT		
PART NO.	HOSE SIZE	NPT SIZE
BN11	1/8"	1/8"
BN151	3/16"	1/8"
BN152	3/16"	1/4"
BN21	1/4"	1/8"
BN22	1/4"	1/4"
BN23	1/4"	3/8"
BN251	5/16"	1/8"
BN252	5/16"	1/4"
BN253	5/16"	3/8"
BN31	3/8"	1/8"
BN32	3/8"	1/4"
BN33	3/8"	3/8"
BN34	3/8"	1/2"
BN42	1/2"	1/4"
BN43	1/2"	3/8"
BN44	1/2"	1/2"
BN46	1/2"	3/4"
BN53	5/8"	3/8"
BN54	5/8"	1/2"
BN56	5/8"	3/4"
BN64	3/4"	1/2"
BN66	3/4"	3/4"
BN86	1"	3/4"
BN88	1"	1"

Stainless Steel Hose Fittings are also available.

Brass Crimp Ferrules

Stainless Steel Hose Fittings are also available.



BRASS FERRULES FOR AIR - BFM FOR MEDIUM WEIGHT HOSE

PART NO.	FERRULE ID	FERRULE LENGTH	END HOLE SIZE	METAL GAUGE	**RIBBED DIE PART NO.	**PLAIN DIE PART NO.
BFM478	.478"	11/16"	21/64"	.024"	R41	P42
BFM478	.562"	1"	7/16"	.024"	R37	P38
BFM478	.593"	1"	7/16"	.024"	R36	P37
BFM478	.625"	1"	7/16"	.024"	R35	P36
BFM478	.656"	1"	7/16"	.024"	R34	P35
BFM478	.687"	1"	1/2"	.024"	R33	P34
BFM478	.718"	1"	5/8"	.024"	R31	P32
BFM478	.718"	1"	1/2"	.024"	R31	P32
BFM478	.750"	1"	5/8"	.024"	R30	P31
BFM478	.750"	1"	1/2"	.024"	R30	P31
BFM478	.781"	1"	5/8"	.024"	R29	P30
BFM478	.781"	1"	1/2"	.024"	R29	P30

E

BRASS FERRULES FOR AIR - BFL FOR LIGHT WEIGHT HOSE

PART NO.	FERRULE ID	FERRULE LENGTH	END HOLE SIZE	METAL GAUGE	**RIBBED DIE PART NO.	**PLAIN DIE PART NO.
BFL380	.380"	1/2"	17/64"	.016"	R44	P45
BFL410	.410"	1/2"	17/64"	.016"	R43	P44
BFL450	.450"	9/16"	11/32"	.016"	R41	P42
BFL500	.500"	1/2"	11/32"	.016"	R40	P41
BFL525	.525"	1/2"	11/32"	.016"	R39	P40
BFL548	.548"	31/64"	3/8"	.016"	R38	P39
BFL564	.564"	3/4"	3/8"	.019"	R37	P38
BFL575	.575"	31/64"	15/32"	.016"	R37	P38
BFL600	.600"	1/2"	1/2"	.016"	R36	P37
BFL625	.625"	1/2"	1/2"	.016"	R35	P36
BFL650	.650"	1/2"	1/2"	.016"	R34	P35
BFL725	.725"	17/32"	1/2"	.016"	R31	P32
BFL750	.750"	17/32"	1/2"	.016"	R30	P31



BRASS FERRULES FOR FLUID - BFW FOR MEDIUM WEIGHT HOSE

PART NO.	FERRULE ID	FERRULE LENGTH	END HOLE SIZE	METAL GAUGE	**RIBBED DIE PART NO.	**PLAIN DIE PART NO.
BF850	.850"	.850"	.568"	.019"	R26	P27
BFW875	.875"	.843"	.688"	.024"	R25	P26
BFW900	.900"	.843"	.688"	.024"	R24	P25
BFW975	.975"	.843"	.688"	.024"	R21	P22
BFW1025	1.025"	.843"	.693"	.024"	R19	P20
BFW1175	1.175"	.843"	.875"	.024"	R13	P14
BFMW1050	1.050"	.843"	.750"	.025"	R18	P19
BFMW1100	1.100"	.843"	.812"	.023"	R16	P17
BFMW1225	1.225"	.875"	.875"	.025"	R11	P12
BFMW1275	1.275"	.875"	1.000"	.025"	R9	P10
BFMW1400	1.400"	.687	1.120"	.030"	R4	P5
BFMW1500	1.500"	.875"	1.120"	.025"	-	P1
BFMW1550	1.550"	.781"	1.120	.020"	-	-



Stainless Steel Hose Fittings are also available.

** These dies are for use with 5111A and 1765A ferrule machines.

Ferrule Crimping Tools



Manually Operated Ferrule Tools

- Scovill No. 5111A - Regular Ferrule Crimping Machine
- Base 8" x 3" - Body 7³/₈" - Height with handle upright 27"
- Weight 29lbs (13kg)

Note: Does not include dies.

Air operated Ferrule Tool Available on request

MANUALLY OPERATED FERRULE TOOL	
PART NO.	
5111A	

E



Hose Crimper

Hose Crimper provides "Big Tool" crimping advantages at a fraction of the cost. Rugged portable and easy to use.

HOSE CRIMPERS	
PART NO.	
855	
855A	



DIES FOR 855/855A					
PART NO.	DIE BORE	NOMINAL HOSE OD		CRIMPER NO. 855A	CRIMPER NO. 855A
		TO	FROM		
856-10	.375"	.385"	.406"	Optional	Optional
856-7	.437"	.447"	.468"	Optional	Standard
856-4	.484"	.490"	.520"	Standard	Standard
856-3	.531"	.540"	.562"	Standard	Standard
856-2	.578"	.590"	.625"	Standard	Standard
856-1	.625"	.640"	.671"	Standard	Standard
856-5	.687"	.690"	.710"	Standard	Optional
856-8	.750"	.760"	.781"	Optional	Optional
856-9	.812"	.820"	.843"	Optional	Optional

855 Crimper with 5 dies for 1/4" - 1 braid through 3/8" - 2 braid hose.

855A same as 855 except the largest die is replaced by 7/16" die for crimping 3/16" hose. (Welding hoses etc.).

Optional dies up to 13/16". (1/2" I.D. Hose available).



Model 860 Large Hose Crimper (Sold without dies)

For crimping larger hoses from 1/2" to 1" I.D., 7/8" to 1 1/2" O.D. Crimps standard brass or aluminium ferrules. Order separate die for each hose diameter.

LARGE HOSE CRIMPERS	
PART NO.	
860	

E



DIES FOR 860	
DIE PART NO.	O.D. HOSE (mm)
861-22	17.5
861-23	18.3
861-24	19.0
861-25	19.8
861-26	20.6
861-27	26.2
861-28	22.2
861-29	23.0
861-30	23.8
861-31	24.6
861-32	25.0
861-33	25.8
861-34	26.6
861-36	28.2
861-38	29.8
861-40	31.4
861-42	32.9
861-44	34.5
861-468	36.1
861-48	37.7

Tuff Lite & Plastic Fittings

Size: 1/8" to 2"

Materials: Nylon
Polypropylene
Kynar

Properties: Nylon Fittings are generally acceptable for working pressures up to 150 psi (10 bar) at normal room temperatures. At very low pressures temperatures can approach 175°F or 79°C with no degradation of the fittings strength. nylon fittings should not be used with acid based fertilisers, bromine, chlorine, flourine, hydrochloric acid, sulphuric acid and xylene. Made with material approved by FDA and NSF. Nylon should not be used with compressed gas.

Polypropylene should not be used with aromatic hydrocarbons, carbon tetra-chloride, petrol, hexane, kerosene, nitric acid, sodium hydrochloride, toluene, trichloroethylene or xylene. Polypropylene should not be used with compressed gas

Details:

- Nylon parts are White
- Polypropylene parts are Black
- Kynar (PVDF) parts are Tan



**FOR MORE INFORMATION ON TUFF LITE AND OTHER PLASTIC FITTINGS
REQUIREMENTS PLEASE CONTACT DIXON ON:**

TELEPHONE: +44 (0)1772 323 529 FAX:+44 (0)1772 314 664 EMAIL: enquiries@dixoneurope.co.uk

Glycerine Filled Pressure Gauges

Stainless Steel liquid filled pressure gauges provide the corrosion resistance and durability of a permanently sealed gauge. Designed for severe service applications

Details: Case: AISI 304 Stainless Steel

Nominal Size: 63mm

Connection: BSPT / NPT / BSP Pl.

Accuracy: 1.5%

Scale: psi / kPa Dual Scale

Ranges: 35 – 10,000 psi

E



63mm DIAL PRESSURE GAUGE

PART NO.	PRESSURE RANGE (psi)
PG00030	0-35
PG00060	0-55
PG00085	0-85
PG00100	0-115
PG00160	0-145
PG00200	0-230
PG00360	0-360
PG00600	0-600
PG00800	0-870
PG01000	0-1160
PG02000	0-2230
PG03500	0-3500
PG05800	0-5800
PG06000	0-6000
PG08000	0-8000
PG10000	0-10000



E

Hose

Air/Water	102-107
- A101AS-T2 Black Anti-Static Air/Water.....	102
- A101HP Black Air/Water.....	103
- A102HP Yellow Air/Water.....	103
- A190 Super Air/Water.....	104
- A210 Water Suction and Delivery.....	105
- Irribulk Green Medium Duty Spiral PVC.....	106
- Delvac Green Tinted Spiral PVC.....	106
- PREMflex MDSE Spiral PVC.....	107
Oil, Chemical & General Purpose	108-114
- A430 Oil Suction and Delivery.....	108
- A400EU Heavy Duty Oil Suction and Delivery.....	108
- A104 Red Multi-Purpose Non-Conductive.....	109
- Baku Oil Blue Spiral PVC.....	110
- A901 Oil Composite.....	111
- A901 Vapour Recovery Composite.....	111
- A906 Chemical Composite.....	112
- A911 PTFE Composite.....	113
- A410 UHMWPE Chemical Suction and Delivery.....	114
Steam	115-116
- A235 Blue Steam Hot Water & Food.....	115
- A235 Black Saturated Steam.....	116
- A230 Red Superheated Steam.....	116

F

Food & Beverage	117-122
- San-Hygienic Food Grade Suction and Delivery	117
- San-Hygienic Premium Food Grade Suction and Delivery	118
- San-Hygienic Food Grade Delivery	119
- SAN-sil™ Silicone Suction and Delivery	120
- PREM-vin Transparent PVC	121
- Delikatesse Non-Toxic Clear PVC	122
 Large Bore Custom Built - Bulkstream	 123-127
 Metallic & PTFE.....	 128-132
 Specialist High Pressure, High Temperature & Armoured	 133-135
 Hose Protection & Fire Jackets	 136-137



**A FULL RANGE OF COMPLEMENTARY FITTINGS
TO SUIT ALL HOSES ARE AVAILABLE THROUGHOUT THIS CATALOGUE**

A101AS-T2 Black Anti-Static Air/Water Hose 20 bar to BS2050:1978

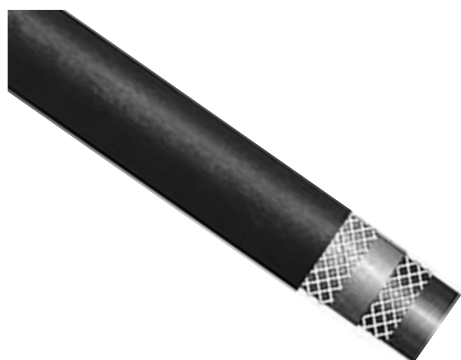

- Application:** Extruded construction all rubber anti-static hose meeting the requirements of BS2050:1978 with conductivity between liner and cover. It is used widely in the offshore oil and gas industry where maintenance using compressors and air driven plant and equipment in a spark free environment is crucial. Pressure and general construction standards to BS EN ISO 2398:2008 and the old BS5118/2:1975.
- Working pressure:** 20 bar (300psi), safety factor 3:1.
- Lining:** Black sbr rubber, oil mist resistant.
- Reinforcement:** High strength textile yarn.
- Cover:** black sbr rubber, ozone and weather resistant.
- Branding:** WHITE (INK JET) A101AS T2 AIR/WATER 20 BAR BS2050 BS5118/2 EN2398 DATE OF MANUFACTURE DIXON ASSEMBLY W.P._____.
- Temperature range:** -20°C to +80°C.

F

PART NUMBER	DIMENSIONS MM		PRESSURE BAR		WEIGHT KG/M (APPROXIMATE)	BEND RADIUS MM (APPROXIMATE)	COIL LENGTH METRE
	OD	OD	WORKING	BURST (MIN)			
A101AS-T2-010	10	17	20	60	0.25	100	120
A101AS-T2-012	12.7	21	20	60	0.35	130	120
A101AS-T2-020	19	29	20	60	0.48	190	120
A101AS-T2-025	25.4	35.5	20	60	0.67	250	120

FOR INSTALLATION AND SAFETY GUIDELINES REFER TO THE TECHNICAL SECTION

A101HP Black Air/Water Hose 20 bar

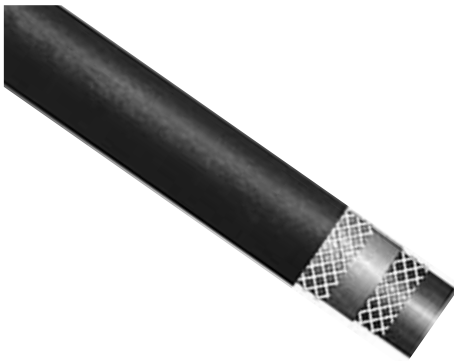

- Application:** General purpose extruded construction all rubber black air/water hose. Suited to a variety of air and water applications in agriculture, construction, plant hire, civil engineering, mining and quarrying. Pressure and general construction standards to BS EN ISO 2398:2008 and the old BS5118/2:1975.
- Working pressure:** 20 bar (300psi), safety factor 3:1.
- Lining:** Black sbr rubber, oil mist resistant.
- Reinforcement:** High strength textile yarn.
- Cover:** Black sbr rubber, ozone and weather resistant.
- Branding:** YELLOW (INK JET) DIXON A101HP AIR/WATER 20 BAR BS5118/2 EN2398 DATE OF MANUFACTURE DIXON ASSEMBLY W.P._____.
- Temperature range:** -20°C to +80°C.

PART NUMBER	DIMENSIONS MM		PRESSURE BAR		WEIGHT KG/M (APPROXIMATE)	BEND RADIUS MM (APPROXIMATE)	COIL LENGTH METRE
	ID	OD	WORKING	BURST (MIN)			
A101HP006	6	13	20	60	0.18	60	100
A101HP008	8	15	20	60	0.21	80	100
A101HP010	10	17	20	60	0.25	100	100
A101HP012	12.7	21	20	60	0.35	130	100
A101HP020	19	29	20	60	0.48	190	100
A101HP025	25.4	35.5	20	60	0.67	250	100

A102HP Yellow Air/Water Hose 20 bar

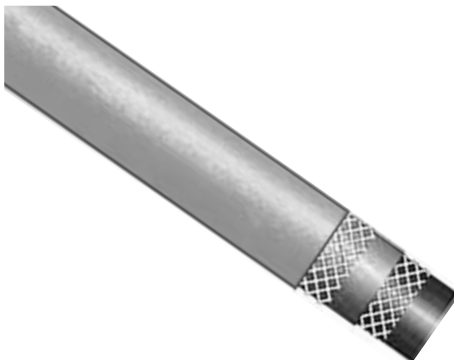

- Application:** General purpose extruded construction all rubber yellow air/water hose. Suited to a variety of air and water applications in agriculture, construction, plant hire, civil engineering, mining and quarrying. Pressure and general construction standards to BS EN ISO 2398:2008 and the old BS5118/2:1975.
- Working pressure:** 20bar (300psi), safety factor 3:1.
- Lining:** Black SBR, oil mist resistant.
- Reinforcement:** High strength textile yarn.
- Cover:** Yellow SBR, ozone and weather resistant.
- Branding:** BLACK INK JET DIXON A102HP AIR/WATER 20 BAR BS5118/2 EN2398 DATE OF MANUFACTURE DIXON ASSEMBLY W.P._____.
- Temperature range:** -20°C to +80°C.

PART NUMBER	DIMENSIONS MM		PRESSURE BAR		WEIGHT KG/M (APPROXIMATE)	BEND RADIUS MM (APPROXIMATE)	COIL LENGTH METRE
	ID	OD	WORKING	BURST (MIN)			
A102HP012	12.7	21	20	60	0.35	130	100
A102HP020	19	29	20	60	0.48	190	100
A102HP025	25.4	35.5	20	60	0.67	250	100

FOR INSTALLATION AND SAFETY GUIDELINES REFER TO THE TECHNICAL SECTION

A190 Super Air/Water Hose 20 bar



Application:	High quality black or yellow air/water hose, mandrel construction. Suited to a variety of air and water applications in construction, plant hire, civil engineering, mining and quarrying where a more robust, durable hose is required. Pressure and general construction standards to BS EN ISO 2398:2008 and the old BS5118/2:1975.
Working pressure:	20 bar (300psi), safety factor 3:1.
Lining:	Black SBR, oil mist resistant.
Reinforcement:	High strength textile yarn.
Cover:	Black or yellow SBR, ozone and weather resistant
Branding:	DIXON A190 AIR/WATER EN2398:2008 20BAR SF 3:1 DATE OF MANUFACTURE DIXON ASSEMBLY W.P. _____ . Yellow tape on black cover and blue tape on yellow cover.
Temperature range:	-35°C to +80°C.

F

BLACK COVER

PART NUMBER	DIMENSIONS MM		PRESSURE BAR		WEIGHT KG/M (APPROXIMATE)	BEND RADIUS MM (APPROXIMATE)	COIL LENGTH METRE
	ID	OD	WORKING	BURST (MIN)			
A190012	13	22	20	60	0.61	91	61
A190020	19	29	20	60	0.60	133	61
A190025	25	35	20	60	0.70	135	61
A190032	32	46	20	60	1.30	224	61
A190038	38	52	20	60	1.50	266	61
A190050	51	65	20	60	1.90	357	61
A190080	76	92	20	60	3.20	532	61

YELLOW COVER

PART NUMBER	DIMENSIONS MM		PRESSURE BAR		WEIGHT KG/M (APPROXIMATE)	BEND RADIUS MM (APPROXIMATE)	COIL LENGTH METRE
	ID	OD	WORKING	BURST (MIN)			
A190012Y	13	22	20	60	0.61	91	61
A190020Y	19	29	20	60	0.60	133	61
A190025Y	25	35	20	60	0.70	135	61
A190032Y	32	46	20	60	1.30	224	61
A190038Y	38	52	20	60	1.50	266	61
A190050Y	51	65	20	60	1.90	357	61
A190080Y	76	92	20	60	3.20	532	61

FOR INSTALLATION AND SAFETY GUIDELINES REFER TO THE TECHNICAL SECTION

A210 Water Suction and Delivery Hose 10 bar



- Application:** General heavy-duty suction and discharge of water and mild water borne slurries. Commonly used on centrifugal and diaphragm pumps throughout a wide range of industries. Can be used with waste water with 5-10 pH.
- Working pressure:** Positive 10 bar (150psi), safety factor 3:1.
Negative 1 bar.
- Lining:** Black SBR.
- Reinforcement:** High strength textile yarn and high tensile carbon steel helix.
- Cover:** Black SBR, ozone and weather resistant.
- Branding:** Green tape DIXON A210 WATER S&D 10 BAR/Vac
1 bar SF 3:1 DATE OF MANUFACTURE DIXON
ASSEMBLY W.P. _____.
- Temperature range:** -35°C to +80°C.

PART NUMBER	DIMENSIONS MM		PRESSURE			WEIGHT KG/M (APPROXIMATE)	BEND RADIUS MM (APPROXIMATE)	COIL LENGTH METRE
			POSITIVE BAR		NEGATIVE BAR			
	ID	OD	WORKING	BURST (MIN)				
A210038	38	47	10	30	1	1.00	266	61
A210050	51	62	10	30	1	1.80	357	61
A210065	63	74	10	30	1	2.20	441	61
A210080	76	87	10	30	1	2.80	532	61
A210100	102	114	10	30	1	4.30	714	61
A210150	152	169	10	30	1	9.50	1064	30.5

F

FOR INSTALLATION AND SAFETY GUIDELINES REFER TO THE TECHNICAL SECTION



Irribulk M Green Spiral PVC Suction and Delivery Hose



- Application:** Medium duty spiral pvc hose used in agriculture, construction, plant hire, and water utilities etc. for the suction and delivery of water, slurries, grain, animal feed and other solids whether on plant or tankers. Can also be used on diluted chemicals.
- Working pressure:** 8 bar (116psi) to 3.3 bar (48psi). Safety factor 3:1 and vacuum 0.78 bar to 0.60 bar depending on bore size. Ratings @ 23°C, +/- 2°C.
- Construction:** Olive green soft pvc with embedded shock resistant semi-rigid white pvc spiral helix.
- Branding:** DIXON IRRIBULK M ASSEMBLY W.P. _____.
- Temperature range:** -15°C to + 60°C.

PART NUMBER	DIMENSIONS MM		PRESSURE @ 23°C (+/- 2°C)			WEIGHT KG/M (APPROXIMATE)	BEND RADIUS MM (APPROXIMATE)	COIL LENGTH METRE
			POSITIVE BAR		NEGATIVE BAR			
	ID	OD	WORKING	BURST		BAR		
AUS025GN	25	31.4	8	24	0.78	0.36	113	30
AUS032GN	32	39	7	21	0.78	0.46	144	30
AUS038GN	38	45.8	6.3	19	0.78	0.57	171	30
AUS050GN	51	59.6	5.3	16	0.78	0.83	230	30
AUS065GN	63	74.8	5	15	0.78	1.00	284	30
AUS080GN	76	86	4.3	13	0.78	1.47	405	30
AUS100GN	102	113	4	12	0.78	2.17	459	30
AUS150GN	152	166.2	3.3	10	0.60	4.36	684	30

Delvac Green Tinted Spiral PVC Suction and Delivery Hose



- Application:** This lighter duty spiral pvc hose is used in agriculture, construction, plant hire, and water utilities etc. for the light suction and delivery of water, slurries whether on plant or tankers. Can also be used on diluted chemicals.
- Working pressure:** 9 bar (130psi) to 6 bar (87psi). Safety factor 3:1 and vacuum 0.70 bar. Ratings @ 23°C, +/- 2°C.
- Construction:** Transparent green soft pvc with rigid white pvc spiral.
- Branding:** DIXON DELVAC ASSEMBLY W.P. _____.
- Temperature range:** -15°C to + 60°C.

PART NUMBER	DIMENSIONS MM		PRESSURE @ 23°C (+/- 2°C)			WEIGHT KG/M (APPROXIMATE)	BEND RADIUS MM (APPROXIMATE)	COIL LENGTH METRE
			POSITIVE BAR		NEGATIVE BAR			
	ID	OD	WORKING	BURST		BAR		
AUS020GTD	19	26.2	8	24	0.7	0.27	102	30
AUS025GTD	25	31.6	6.5	19.5	0.7	0.30	127	30
AUS032GTD	32	39.2	5.5	16.5	0.7	0.46	140	30
AUS038GTD	38	45.4	4.5	13.5	0.7	0.55	150	30
AUS050GTD	51	58.6	4.5	13.5	0.7	0.81	200	30

FOR INSTALLATION AND SAFETY GUIDELINES REFER TO THE TECHNICAL SECTION

PREMflex MDSE Spiral PVC Suction and Delivery Hose



- Application:** This premium quality medium duty super elastic (MDSE) spiral pvc hose is suitable for most suction and delivery applications in conveying chemical solutions, abrasive slurries and solids such as grain, animal feeds and small aggregate. Provides exceptional low temperature flexibility and low friction/abrasion when dragged across surfaces.
- Working pressure:** 5.3 bar (77psi) to 3.3 bar (48psi). Safety factor 3:1 and vacuum 0.90 bar. Ratings @ 23°C, +/- 2°C.
- Construction:** Grey specially compounded super elastic pvc with rigid blue pvc spiral.
- Branding:** DIXON PREMflex ASSEMBLY
W.P. _____.
- Temperature range:** -25°C to + 65°C.

PART NUMBER	DIMENSIONS MM		PRESSURE @ 23°C (+/- 2°C)			WEIGHT KG/M (APPROXIMATE)	BEND RADIUS MM (APPROXIMATE)	COIL LENGTH METRE
			POSITIVE BAR		NEGATIVE BAR			
	ID	OD	WORKING	BURST				
AUS038GB	38	48	5.3	16	0.9	0.70	114	30
AUS050GB	51	61	5	15	0.9	1.05	153	30
AUS065GB	63	75.2	4.7	14	0.9	1.39	189	30
AUS080GB	76	89	4.3	13	0.9	1.70	228	30
AUS100GB	102	117	4	12	0.9	2.70	306	30
AUS125GB	127	143.5	3.3	10	0.9	3.90	381	30
AUS150GB	152	171	3.3	10	0.9	5.00	456	30

F

FOR INSTALLATION AND SAFETY GUIDELINES REFER TO THE TECHNICAL SECTION



A430 - Oil Suction and Delivery Hose 10 bar



- Application:** Designed for suction and discharge use on various petroleum products with upto 50% aromatic content, whether in plant or on tankers. Is suitable for handling unleaded fuels and hydraulic oils in return lines and wet diesel exhaust.
- Working pressure:** 10 bar (150psi), safety factor 3:1. Vacuum I bar.
- Lining:** Black NBR for 50% aromatics.
- Reinforcement:** High strength textile yarn, high tensile carbon steel helix and copper anti-static wire.
- Cover:** Black CR oil, ozone and weather resistant.
- Branding:** Red tape DIXON A430 OIL S&D 10 BAR VAC 1 BAR SF 3:1-DATE OF MANUFACTURE DIXON ASSEMBLY W.P._____.
- Temperature range:** -30°C to +80°C.

PART NUMBER	DIMENSIONS MM		PRESSURE BAR			WEIGHT KG/M (APPROXIMATE)	BEND RADIUS MM (APPROXIMATE)	COIL LENGTH METRE
			POSITIVE		VACUUM			
	ID	OD	WORKING	BURST (MIN)				
A430020	19	29	10	30	1	0.60	140	61
A430025	25	35	10	30	1	0.70	178	61
A430032	32	42	10	30	1	0.80	224	61
A430038	38	47	10	30	1	0.90	266	61
A430050	51	62	10	30	1	1.60	357	61
A430065	63	74	10	30	1	1.90	441	61
A430080	76	87	10	30	1	2.50	530	61
A430100	102	114	10	30	1	3.80	714	61
A430150	152	172	10	30	1	9.50	1064	30.5

A400EU Heavy Duty Oil Suction and Delivery Hose 20 bar



- Application:** Designed for suction and discharge use on various petroleum products with upto 50% aromatic content. Also suited to handling seawater, mud and general offshore applications and bunkering.
- Working pressure:** 20 bar (300psi), safety factor 4:1. Vacuum 0.90 bar to 0.70 bar depending on bore size.
- Lining:** Black NBR for 50% aromatics.
- Reinforcement:** High strength textile yarn, high tensile carbon steel helix and copper anti-static wire.
- Cover:** Black CR oil, ozone and weather resistant.
- Branding:** Red tape DIXON BULKSTREAM A400EU OIL S&D 20 BAR SF 4:1 DATE OF MANUFACTURE.
- Temperature range:** -30°C to +80°C.

PART NUMBER	DIMENSIONS MM		PRESSURE BAR			WEIGHT KG/M (APPROXIMATE)	BEND RADIUS MM (APPROXIMATE)	COIL LENGTH METRE
			POSITIVE		VACUUM			
	ID	OD	WORKING	BURST (MIN)				
A400EU076	76	94	20	80	0.90	3.40	532	40
A400EU100	102	126	20	80	0.90	4.80	714	40
A400EU150	152	181	20	80	0.80	10.90	1064	20
A400EU200	203	240	20	80	0.70	18.70	1421	TO ORDER

All bore sizes available in straight cured cut lengths to special order

FOR INSTALLATION AND SAFETY GUIDELINES REFER TO THE TECHNICAL SECTION

A104 Red Multi-Purpose Non-Conductive Hose

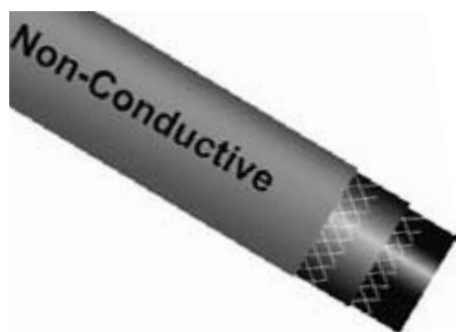

- Application:** Multi-purpose hose suitable for use in steel works, foundries, auto plants, general engineering and construction for conveying and de-canting a broad range of oils, greases and solvents (OGS). **If in doubt on compatibility of solvents please refer to the Dixon sales office.**
- Working pressure:** 20bar (300psi) to 14 bar (200psi) depending on bore size, safety factor 4:1.
- Lining:** Black NBR.
- Reinforcement:** High strength textile yarn.
- Cover:** Red nitrile blend, oil, solvent, abrasion and ozone resistant.
- Branding:** WHITE INK JET DIXON A104 NON CONDUCTIVE MULTIPURPOSE 300PSI WP SF 4:1 DIXON ASSEMBLY WP_____ in bore sizes 6mm to 25mm inclusive. 32mm & 38mm bore WP print 250PSI and 51mm 200PSI.
- Temperature range:** -20°C to +100°C.

F

PART NUMBER	DIMENSIONS MM		PRESSURE BAR		WEIGHT KG/M (APPROXIMATE)	BEND RADIUS MM (APPROXIMATE)	COIL LENGTH METRE
	ID	OD	WORKING	BURST (MIN)			
A104006	6	16	20	80	0.24	55	100
A104008	8	18	20	80	0.25	73	100
A104010	10	19	20	80	0.27	90	100
A104012	12.5	22	20	80	0.38	115	100
A104016	16	26	20	80	0.43	150	100
A104020	19	30	20	80	0.63	175	100
A104025	25	38	20	80	0.96	225	100
A104032	32	45	17	68	1.24	320	30
A104038	38	53	17	68	1.44	380	30
A104050	51	67	14	56	1.50	500	30

FOR INSTALLATION AND SAFETY GUIDELINES REFER TO THE TECHNICAL SECTION



Baku Oil Blue Spiral PVC Suction and Delivery Hose



- Application:** Suitable for light suction and delivery of fuel oils with a low aromatic whether used in applications on plant or tankers. These include lubricating oils, hydraulic oils, diesel, kerosene, white spirit and other petroleum derivatives.
- Working pressure:** 9.7 bar (140psi) to 2 bar (29psi). Safety factor 3:1. Vacuum 0.88 bar to 0.78 bar depending on bore size. Ratings @ 23°C, +/- 2°C.
- Construction:** Blue soft nitrated pvc with embedded shock resistant semi-rigid white pvc spiral helix.
- Branding:** DIXON BAKU OIL HOSE DIXON ASSEMBLY W.P. _____.
- Temperature range:** -15°C to + 60°C.

PART NUMBER	DIMENSIONS MM		PRESSURE BAR			WEIGHT KG/M (APPROXIMATE)	BEND RADIUS MM (APPROXIMATE)	COIL LENGTH METRE
			POSITIVE		VACUUM			
	ID	OD	WORKING	BURST (MIN)				
AUS025BHD	25	33.4	9.7	29.1	0.88	0.485	113	30
AUS032BHD	32	40.8	8	24	0.88	0.580	144	30
AUS038BHD	38	47	8	24	0.88	0.680	171	30
AUS050BHD	51	60.4	6	18	0.88	1.040	230	30
AUS065BHD	63	73.4	5	15	0.88	1.360	284	30
AUS080BHD	76	87.6	4.7	14.1	0.88	1.700	342	30
AUS100BHD	102	115.5	3	9	0.88	2.620	459	30
AUS150BHD	152	167.6	2	6	0.78	4.430	684	10

FOR INSTALLATION AND SAFETY GUIDELINES REFER TO THE TECHNICAL SECTION

A901 (GG) Composite Oil Hose 14 bar



Application:

This anti-static composite hose is designed for suction and discharge use on plant or road/rail tankers with a wide range of hydrocarbons where 100% aromatic resistance is required. The hose construction is exceptionally lightweight and flexible for ease of handling yet remains robust, hardwearing and cost effective.

Hose and assembling specification in accordance with BS EN 13765: 2010.

Electrically resistant to less than 10 ohms, as required by BS 5842: 1980 clause 6.2.

Working pressure:

14 bar (203 psi), safety factor 4:1. Vacuum 0.90 bar.

Hose construction:

Polypropylene and Polyethylene films and fabrics with **black** weather-proof and abrasion resistant outer cover wrapped and tensioned between internal and external wire spirals. Inner and outer wire spiral, galvanised carbon steel (GG).

Branding:

Yellow spiral tape DIXON A901 OIL TYPE 3 BS EN 13765: 2010 14 BAR 80°C PP.

Temperature range:

-30°C to +80°C.

F

A901(GG) COMPOSITE OIL HOSE						
NOMINAL BORE MM	PRESSURE BAR			WEIGHT KG/M (APPROXIMATE)	BEND RADIUS MM (APPROXIMATE)	MAXIMUM COIL LENGTH METRE
	POSITIVE		VACUUM			
	WORKING	BURST (MIN)				
25	14	56	0.90	0.75	75	30
32	14	56	0.90	1.00	80	30
40	14	56	0.90	1.40	85	30
50	14	56	0.90	2.00	125	30
65	14	56	0.90	2.80	150	30
75	14	56	0.90	3.50	175	30
100	14	56	0.90	4.80	250	30

A901AG VAPOUR RECOVERY HOSE – ORANGE COVER						
NOMINAL BORE MM	PRESSURE BAR			WEIGHT KG/M (APPROXIMATE)	BEND RADIUS MM (APPROXIMATE)	MAXIMUM COIL LENGTH METRE
	POSITIVE		VACUUM			
	WORKING	BURST (MIN)				
76	10	40	0.90	2.10	185	30
100	10	40	0.90	2.90	275	30

(A = aluminium internal wire, G = galvanised steel outer wire)

ASSEMBLIES MADE TO CUSTOMER SPECIFICATION

FOR INSTALLATION AND SAFETY GUIDELINES REFER TO THE TECHNICAL SECTION



A906 (PG) Composite Chemical Hose 14 bar



Application:

This anti-static composite hose is designed for suction and discharge use on plant or road/rail tankers with a wide range of chemicals. The hose construction is exceptionally lightweight and flexible for ease of handling yet remains robust, hardwearing and cost effective.

Hose and assembling specification in accordance with BS EN 13765: 2010.

Electrically resistant to less than 10 ohms, as required by BS 5842: 1980 clause 6.2.

Working pressure:

14 bar (203 psi), safety factor 4:1. Vacuum 0.90 bar.

Hose construction:

Polypropylene and polyethylene films and fabrics with **grey** weather-proof and abrasion resistant outer cover wrapped and tensioned between internal and external wire spirals. Inner wire spiral, polypropylene coated mild steel (P), outer wire spiral galvanised carbon steel (G).

Other wire combinations available are.

A906PS (P = polypropylene coated carbon steel internal wire, S = stainless steel external wire) with green marker stripe to denote stainless steel external wire.

Branding:

Yellow spiral tape DIXON A906 CHEMICAL TYPE 3 BS EN 13765: 2010 14 BAR 80°C PP.

Temperature range:

-30°C to +80°C.

NOMINAL BORE MM	PRESSURE BAR			WEIGHT KG/M (APPROXIMATE)	BEND RADIUS MM (APPROXIMATE)	MAXIMUM COIL LENGTH METRE
	POSITIVE		VACUUM			
	WORKING	BURST (MIN)				
25	14	56	0.90	0.75	75	30
32	14	56	0.90	1.00	80	30
40	14	56	0.90	1.40	85	30
50	14	56	0.90	2.00	125	30
65	14	56	0.90	2.80	150	30
75	14	56	0.90	3.50	175	30
100	14	56	0.90	4.80	250	30

ASSEMBLIES MANUFACTURED TO CUSTOMER SPECIFICATION

FOR INSTALLATION AND SAFETY GUIDELINES REFER TO THE TECHNICAL SECTION

A911 (SG) Composite PTFE Chemical Hose 14 bar



Application:

This anti-static PTFE lined composite hose is designed for suction and discharge use on plant or road/rail tankers with a wide range of aggressive chemicals or foods. The hose construction is exceptionally lightweight and flexible for ease of handling yet remains robust, hardwearing and cost effective.

Hose and assembling specification in accordance with BS EN 13765: 2010.

Electrically resistant to less than 10 ohms, as required by BS 5842: 1980 clause 6.2.

Working pressure:

14 bar (203 psi), safety factor 4:1. Vacuum 0.90 bar.

Hose construction:

PTFE lined with polypropylene and polyethylene films and fabrics with red weather-proof and abrasion resistant outer cover wrapped and tensioned between internal and external wire spirals. Internal wire spiral, stainless steel (S), external wire spiral, galvanised carbon steel (G).

Other wire combinations available are.

A911SS (S = stainless steel internal and external wires) with green marker stripe to denote stainless steel external wire.

Branding:

Yellow spiral tape DIXON A911 PTFE TYPE 3 BS EN 13765: 2010 14 BAR 115°C PTFE.

Temperature range:

-30°C to +115°C.

F

NOMINAL BORE MM	PRESSURE			WEIGHT KG/M (APPROXIMATE)	BEND RADIUS MM (APPROXIMATE)	MAXIMUM COIL LENGTH METRE
	POSITIVE		VACUUM			
	WORKING	BURST				
25	14	56	675	0.90	75	30
32	14	56	675	1.00	80	30
40	14	56	675	1.40	85	30
50	14	56	675	2.00	125	30
65	14	56	675	3.20	150	30
75	14	56	675	3.60	180	30
100	14	56	675	5.00	250	30

ASSEMBLIES MANUFACTURED TO CUSTOMER SPECIFICATION

FOR INSTALLATION AND SAFETY GUIDELINES REFER TO THE TECHNICAL SECTION



A410 UHMWPE Chemical Suction and Delivery Hose 10 bar



- Application:** Designed for suction and discharge use on a wide range of chemicals and acids on plant or road/rail tanker.
- Working pressure:** 10 bar (150psi), safety factor 4:1. Vacuum 0.93 bar.
- Lining:** Black ultra high molecular weight polyethylene (UHMWPE).
- Reinforcement:** High strength textile yarn, high tensile carbon steel helix and copper anti-static wires.
- Cover:** Blue EPDM chemical ozone and weather resistant.
- Branding:** White tape DIXON A410 CHEMICAL S&D UHMWPE 10BAR/0.93 BAR SF 4:1 - DATE OF MANUFACTURE.
- Temperature range:** -35°C to +100°C. For short periods UHMWPE can also resist steam up to 130°C, **but please note it has a melting temperature of 135°C. IF IN DOUBT PLEASE CONSULT OUR SALES OFFICE.**

F

PART NUMBER	DIMENSIONS MM		PRESSURE BAR			WEIGHT KG/M (APPROXIMATE)	BEND RADIUS MM (APPROXIMATE)	COIL LENGTH METRE
			POSITIVE		VACUUM			
	ID	OD	WORKING	BURST (MIN)				
A410020	19	31	10	40	0.93	0.60	133	61
A410025	25	37	10	40	0.93	0.80	175	61
A410032	32	44	10	40	0.93	0.90	224	61
A410038	38	51	10	40	0.93	1.20	266	61
A410050	51	65	10	40	0.93	1.90	357	61
A410065	63	77	10	40	0.93	2.20	441	61
A410080	76	91	10	40	0.93	3.00	532	61
A410100	102	119	10	40	0.93	4.40	714	61

FOR INSTALLATION AND SAFETY GUIDELINES REFER TO THE TECHNICAL SECTION

A235 - Steam Hot Water & Food Hose 7 bar



- Application:** Multi functional premium quality mandrel built steam, hot water and food hose. Widely used in the food industry sector e.g. creameries, bottling plants, breweries, dairies, food processing, including abattoirs. Resistant to fatty foods. Cover non-marking and pricked to allow ventilation of heat when used at high temperatures and reduce the risk of separation
- Working pressure:** 7 bar (101 psi) steam. 17 bar (246 psi) hot wash upto +95°C. Designed burst pressure 70 bar (1015 psi)
- Lining:** Extruded white food grade EPDM, FDA approved compounds.
- Reinforcement:** High strength textile yarns
- Cover:** Blue EPDM, pin pricked
- Branding:** White tape DIXON logo A235 STEAM HOT WATER FOOD FDA 7BAR SF 10:1 DATE OF MANUFACTURE DIXON ASSEMBLY W.P. _____
- Temperature range:** -20°C to +170°C

PART NUMBER	DIMENSIONS MM		PRESSURE BAR		WEIGHT KG/M (APPROXIMATE)	BEND RADIUS MM (APPROXIMATE)	COIL LENGTH METRE
	ID	OD	WORKING	BURST (MIN)			
A235012BU	13	24	7	70	0.40	91	40
A235016BU	16	28	7	70	0.50	112	40
A235020BU	19	32	7	70	0.60	133	40
A235025BU	25	39	7	70	0.80	175	40

A235 - Black Steam Hose to BS5122:1986: A2 7 bar



- Application:** Steam hose for handling SATURATED STEAM and manufactured in accordance with BS5122:1986:A2. Used in many applications throughout industry. Avoid excessive contamination with oil
- Working pressure:** 7 bar (101psi). Safety factor 10:1
- Lining:** Extruded black EPDM
- Reinforcement:** High strength textile yarns
- Cover:** Black EPDM, pin pricked
- Branding:** Emboss brand DIXON A235 STEAM 7 BAR SF 10:1 170°C BS5122 A2 1986 DRAIN AFTER USE DATE OF MANUFACTURE DIXON ASSEMBLY W.P. _____
- Temperature range:** -20°C to +170°C

PART NUMBER	DIMENSIONS MM		PRESSURE BAR		WEIGHT KG/M (APPROXIMATE)	BEND RADIUS MM (APPROXIMATE)	COIL LENGTH METRE
	ID	OD	WORKING	BURST (MIN)			
A235012BK	13	25	7	70	0.40	91	40
A235020BK	19	32	7	70	0.60	133	40
A235025BK	25	40	7	70	0.90	175	40

FOR INSTALLATION AND SAFETY GUIDELINES REFER TO THE TECHNICAL SECTION

A230 - Red Steam Hose to BS5342:1986: A2 18 bar



- Application:** Steam hose for handling SUPERHEATED STEAM and manufactured in accordance with BS5342:1986:A2. Widely used in petrochemical plants/referies for maintenance and pipe insulation during freezing weather conditions. Avoid excessive contamination with oil
- Working pressure:** 18 bar (261 psi). Safety factor 10:1
- Lining:** Extruded black EPDM
- Reinforcement:** High tensile brass coated stranded steel wire
- Cover:** Red EPDM, pin pricked
- Branding:** Emboss brand DIXON A230 STEAM 18 BAR SF 10:1 210°C BS5342 A2 1986 DRAIN AFTER USE DATE OF MANUFACTURE DIXON ASSEMBLY W.P. _____
- Temperature range:** -20°C to + 210°C and intermittent to 232°C

F

PART NUMBER	DIMENSIONS MM		PRESSURE BAR		WEIGHT KG/M (APPROXIMATE)	BEND RADIUS MM (APPROXIMATE)	COIL LENGTH METRE
	ID	OD	WORKING	BURST (MIN)			
A230012	13	27	18	180	0.50	52	40
A230020	19	33	18	180	0.70	76	40
A230025	25	40	18	180	0.90	100	40
A230032	32	46	18	180	1.30	128	40
A230038	38	54	18	180	1.65	152	40
A230050	51	68	18	180	2.20	200	40

STEAM IS DANGEROUS.

WE STRONGLY RECOMMEND THE USE OF GENUINE DIXON BOSS STEAM COUPLINGS & CLAMPS.

DO NOT COMPROMISE SAFETY.

FOR INSTALLATION & SAFETY GUIDELINES REFER TO THE TECHNICAL SECTION

San-Hygienic Food Grade Suction and Delivery Hose 10 bar

- Application:** SAN-HYGIENIC and SAN-HYGIENIC CRUSHA are high quality suction and delivery hoses and have for many years been leading brands within the food industry. Manufactured from odourless and taste free rubber materials approved by the FDA, are free of phthalates and animal derivatives, and are highly flexible smooth bore hoses suitable for the transfer of liquid foodstuffs. These include beers, wines (alcohol concentration up to 96% @ 20°C), soft-drinks, milk, dairy products, mineral waters, potable water, oily fatty foods, chocolates, milks, creams and sauces etc. **Compounds free from phthalates and animal derivatives.**
- Working pressure:** 10 bar (150psi), safety factor 3:1. Vacuum 0.90 bar or 0.60 bar as appropriate.
- Lining:** FDA compliant, white smooth food grade NBR, grease and oil resistant.
- Reinforcement:** SAN-HYGIENIC - high strength synthetic plies, twin carbon steel helices. SAN-HYGIENIC CRUSHA - high strength synthetic plies and embedded nylon helix.
- Cover:** SAN-HYGIENIC cloth finish smooth blue or red SBR/EPDM blend, resistant to abrasion and ozone. SAN-HYGIENIC CRUSHA cloth finish blue convoluted SBR/EPDM blend, resistant to abrasion and ozone. **Compounds free from phthalates and animal derivatives.**
- Branding:** White background tape - DIXON logo SAN-HYGIENIC FDA 10 bar SF 3:1 Vac 0.90 bar, DIXON logo SAN-HYGIENIC CRUSHA FDA 10 bar SF 3:1 Vac 0.60 bar, as appropriate.
- Temperature range:** -35°C to +80°C. Cleaning in accordance with 3-A Sanitary Standard Class II, steam sterilisation up to 121°C for 30 minutes at maximum 2 bar pressure, bactericidal treatment with chemical solutions up to 82°C at maximum 10 bar pressure, depending on solution and concentration.



F

SAN-HYGIENIC (SMOOTH)									
PART NO.S		DIMENSIONS MM		PRESSURE BAR			WEIGHT KG/M (APPROX)	BEND RADIUS MM (APPROX)	COIL LENGTH METRE
				POSITIVE		VACUUM			
RED	BLUE	ID	OD	WORKING	BURST (MIN)				
SANB020	SANF020	19	30	10	30	0.90	0.6	95	40
SANB025	SANF025	25	36	10	30	0.90	0.7	125	40
SANB038	SANF038	38	51.5	10	30	0.90	1.3	190	40
SANB050	SANF050	51	65.5	10	30	0.90	2.0	255	40
SANB065	SANF065	63	79	10	30	0.90	2.7	315	40
SANB080	SANF080	76	92	10	30	0.90	3.4	380	40
SANB100	SANF100	102	120.5	10	30	0.90	5.3	510	40

SAN-HYGIENIC CRUSHA (CONVOLUTED)									
PART NO.	DIMENSIONS MM		PRESSURE BAR			WEIGHT KG/M (APPROX)	BEND RADIUS MM (APPROX)	COIL LENGTH METRE	
			POSITIVE		VACUUM				
	ID	OD MIN/MAX	WORKING	BURST (MIN)					
SANC050	51	67/74	10	30	0.60	1.97	210	40	
SANC065	63	79/86.5	10	30	0.60	2.37	280	40	
SANC080	76	92/98	10	30	0.60	3.60	430	40	

All sizes are available in loose lengths or assemblies with all types of Holedall® External Crimp and IX Internal Expansion 316 stainless steel hygienic end connections in RJT, DIN, SMS, IDF, and Tri-Clamp form.

FOR INSTALLATION AND SAFETY GUIDELINES REFER TO THE TECHNICAL SECTION



San-Hygienic PREMIUM Food Grade Suction and Delivery Hose 16 bar



- Application:** SAN-HYGIENIC PREMIUM is a higher pressure and temperature suction and delivery hose. Manufactured from odourless and taste free rubber materials approved by the FDA, are free of phthalates and animal derivatives, and are highly flexible smooth bore hoses suitable for the transfer of liquid foodstuffs. These include beers, wines (alcohol concentration up to 96% @ 20°C), soft-drinks, milk, dairy products, mineral waters, potable water, oily fatty foods, chocolates, milks, creams and sauces etc. **Compounds free from phthalates and animal derivatives.**
- Working pressure:** 16 bar (232psi), safety factor 3:1. Vacuum 0.90 bar.
- Lining:** FDA compliant, white smooth food grade NBR, grease and oil resistant.
- Reinforcement:** High strength synthetic plies, twin carbon steel helices.
- Cover:** Cloth finish, Greco rope impression convolution, blue or red SBR/EPDM blend, resistant to abrasion and ozone. **Compounds free from phthalates and animal derivatives.**
- Branding:** White background tape - DIXON logo
SAN-HYGIENIC PREMIUM FDA 100°C 16 bar SF 3:1
Vac 0.90 bar.
- Temperature range:** -35°C to +100°C. Cleaning in accordance with 3-A Sanitary Standard Class II, steam sterilisation up to 130°C for 30 minutes at maximum 2 bar pressure, bactericidal treatment with chemical solutions up to 82°C at maximum 10 bar pressure, depending on solution and concentration.

PART NO.S		DIMENSIONS MM		PRESSURE BAR			WEIGHT KG/M (APPROX)	BEND RADIUS MM (APPROX)	COIL LENGTH METRE
				POSITIVE		VACUUM			
RED	BLUE	ID	OD	WORKING	BURST (MIN)				
SANB020-PREM	SANF020-PREM	19	30	16	48	0.90	0.6	50	40
SANB025-PREM	SANF025-PREM	25	36	16	48	0.90	0.7	63	40
SANB038-PREM	SANF038-PREM	38	51.5	16	48	0.90	1.4	95	40
SANB050-PREM	SANF050-PREM	51	65.5	16	48	0.90	2.1	130	40
SANB065-PREM	SANF065-PREM	63	79	16	48	0.90	2.7	160	40
SANB080-PREM	SANF080-PREM	76	92	16	48	0.90	3.4	228	40
SANB100-PREM	SANF100-PREM	102	120.5	16	48	0.90	5.4	310	40

All sizes are available in loose lengths or assemblies with all types of Holedall® External Crimp and IX Internal Expansion 316 stainless steel hygienic end connections in RJT, DIN, SMS, IDF, and Tri-Clamp form.

FOR INSTALLATION AND SAFETY GUIDELINES REFER TO THE TECHNICAL SECTION

SAN-HYGIENIC Food Grade Delivery Hose 10 bar



- Application:** SAN-HYGIENIC hoses and have for many years been leading brands within the food industry. Manufactured from odourless and taste free rubber materials approved by the FDA, they are highly flexible smooth bore, soft wall (delivery only) hoses suitable for the transfer of non fatty liquid foodstuffs. These include beers, wines (alcohol concentration up to 96% @ 20°C), soft-drinks, fruit juice, mineral waters and potable water. **Compounds free from phthalates and animal derivatives.**
- Working pressure:** 10 bar (150psi), safety factor 3:1.
- Lining:** FDA approved, white smooth food grade EPDM.
- Reinforcement:** High tensile textile cords.
- Cover:** Cloth finish, smooth red EPDM, resistant to abrasion and ozone.
- Branding:** Emboss - DIXON SAN-HYGIENIC DELIVERY FDA 10 bar SF 3:1.
- Temperature range:** -35°C to +90°C. Cleaning in accordance with 3-A Sanitary Standard Class II, steam sterilisation up to 130°C for 30 minutes at maximum 2 bar pressure in an open system , bactericidal treatment with chemical solutions up to 82°C at maximum 10 bar pressure, depending on solution and concentration.

PART NO.	DIMENSIONS MM		PRESSURE BAR		WEIGHT KG/M (APPROX)	BEND RADIUS MM (APPROX)	COIL LENGTH METRE
	ID	OD	WORKING	BURST (MIN)			
SANB013-DEL	13	23	10	30	0.3	91	40
SANB020-DEL	19	29	10	30	0.5	133	40
SANB025-DEL	25	37	10	30	0.7	175	40

All sizes are available in loose lengths or assemblies with all types of Holedall® External Crimp and IX Internal Expansion 316 stainless steel hygienic end connections in RJT, DIN, SMS, IDF, and Tri-Clamp form.

FOR INSTALLATION AND SAFETY GUIDELINES REFER TO THE TECHNICAL SECTION



San-sil™ Silicone Suction and Delivery Hose



Application:

San-sil is a premium grade platinum cured, odourless, tasteless and completely non-toxic silicone suction and delivery hose with a smooth liner and cover. It is an ideal hose for all types of applications transferring liquid or semi-liquid chemical, food, cosmetic and pharmaceutical product. It is not suitable for handling abrasive particles. Meets or exceeds European Pharmacopoeia 3.1.9, FDA CFR 177.2600, BgVV & L11A and USP XXV1 Class V1.

Working pressure:

10 bar (145psi) to 3 bar (46psi) depending on bore size, safety factor 4:1. Full vacuum up to and including 51mm bore.

Lining:

FDA compliant transparent seamless extruded* smooth silicone.

Reinforcement:

Polyester fabrics, 316L stainless steel wire helix.

Cover:

FDA compliant transparent smooth silicone.

Temperature range:

-60°C to +180°C. (short periods +220°C
Sterilisation by hot air or steam at +134°C, pressure 2.07 bar. The maximum recommended time at 135°C is 45minutes.

F

PART NUMBER	DIMENSIONS MM		PRESSURE BAR		WEIGHT KG/M (APPROXIMATE)	BEND RADIUS MM (APPROXIMATE)	COIL LENGTH METRE
			POSITIVE @ 20°C	VACUUM			
	ID	OD	WORKING	BURST (MIN)			
SANS012	13	25	10	40	1.0	45	4
SANS019	19	31	10	40	1.0	65	4
SANS025	25	38	10	40	1.0	80	4
SANS038	38	51	10	40	1.0	150	4
SANS050	51	63	10	40	1.0	180	4
SANS065	63	76	7	28	0.5	220	4
SANS065	76	89	4	16	0.5	250	4
SANS100	102	114	3	12	0.5	360	4

* in bore sizes upto and including 63mm.

All sizes are available in loose lengths or assemblies with all types of Holedall® External Crimp and IX Internal Expansion 316 stainless steel hygienic end connections in RJT, DIN, SMS, IDF, and Tri-Clamp form. Bounce rings or spiral guard protection available.

FOR INSTALLATION AND SAFETY GUIDELINES REFER TO THE TECHNICAL SECTION

PREM-vin Transparent PVC Suction and Delivery Hose



Application: Premium quality wire embedded food grade crystal clear pvc suction and delivery hose. Can be used for the transfer of many abrasive and non-abrasive food or non-edible materials whether solid or liquid including diluted chemicals. Precise placement and pitch of the spring steel wire spiral provides a high degree of flexibility and resistance to kinking and vacuum under the most arduous of conditions. Transparency reveals any line blockages that may occur. Steel spiral provides continuity for static dispersal provided it is securely connected to an earth path.

Food approved according to EEC 97/48 Classes A, B & C.

Working pressure: 12 bar (174 psi) to 3 bar (43.5 psi) depending on bore size. Safety factor 3:1. Vacuum 0.88 bar. Ratings @ 23°C +/- 2°C.

Hose construction: Crystal clear food grade soft pvc with fully embedded spring steel spiral helix. Smooth bore.

Branding: DIXON PREMVIN SUCTION DIXON ASSEMBLY W.P._____.

Temperature range: -15°C to +65°C.

PART NUMBER	DIMENSIONS MM		PRESSURE BAR @ 23°C +/- 2°C			WEIGHT KG/M (APPROXIMATE)	BEND RADIUS MM (APPROXIMATE)	COIL LENGTH METRE
			POSITIVE		VACUUM			
	ID	OD	WORKING	BURST (MIN)				
ARM012	13	19.2	12	36	0.88	0.21	26	30
ARM020	19	26	11	33	0.88	0.33	38	30
ARM025	25	33	11	33	0.88	0.52	50	30
ARM032	32	40.2	10	30	0.88	0.66	80	30
ARM038	38	47	10	30	0.88	0.80	95	30
ARM050	51	61.8	8	24	0.88	1.30	128	30
ARM065	63	74	7	21	0.88	1.80	158	30
ARM080	76	89.6	5	15	0.88	2.30	190	30
ARM100	102	118	5	15	0.88	3.70	255	30
ARM125	127	143.2	4	12	0.88	4.70	381	30
ARM150	152	170.4	3	9	0.88	6.90	456	20

FOR INSTALLATION AND SAFETY GUIDELINES REFER TO THE TECHNICAL SECTION

Delikatesse Non-Toxic Clear PVC Suction and Delivery Hose

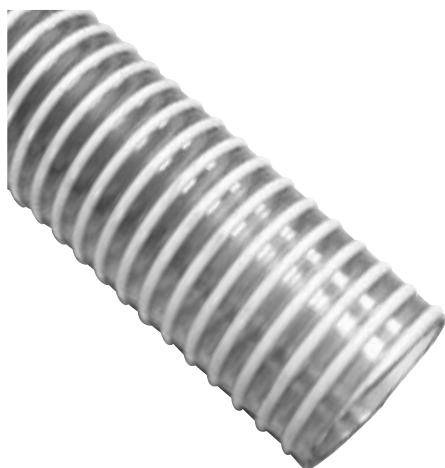

- Application:** Lightweight and highly flexible clear food grade pvc suction and delivery hose for use with various foodstuffs liquid or solid even at low temperatures.
- Working pressure:** 8 bar (116 psi) to 4 bar (58 psi) dependant on bore size.
Safety factor 3:1. Vacuum 0.68 bar. Ratings @ 23°C +/- 2°C.
- Construction:** Crystal transparent food grade soft pvc with embedded shock resistant semi-rigid white pvc spiral helix. Smooth bore.
- Branding:** DIXON DELIKATESSE DIXON ASSEMBLY W.P. _____.
- Temperature range:** -15°C to +65°C.

F

PART NUMBER	DIMENSIONS MM		PRESSURE BAR @ 23°C +/- 2°C			WEIGHT KG/M (APPROXIMATE)	BEND RADIUS MM (APPROXIMATE)	COIL LENGTH METRE
			POSITIVE		VACUUM			
	ID	OD	WORKING	BURST (MIN)				
AUS025FBW	25	31.6	8	24	0.68	0.33	114	30
AUS032FBW	32	39.2	7	22.5	0.68	0.46	143	30
AUS038FBW	38	45.4	6.5	19.5	0.68	0.55	171	30
AUS050FBW	51	59.2	6	18	0.68	0.81	230	30
AUS065FBW	63	70.8	5	15	0.68	1.04	264	30
AUS080FBW	76	86.4	4	12	0.68	1.38	342	30

FOR INSTALLATION AND SAFETY GUIDELINES REFER TO THE TECHNICAL SECTION

Dixon BULKSTREAM

Custom built, specially made to order rubber hose and assemblies.

This special range of what are often referred to as hand-built hoses generally facilitates features or specifications to a hose that is unique to a customer's application or duty, providing reliability of service, longevity of life, cost effectiveness and adds to a safer working environment.

Typical applications and duties are conveying edible and non-edible liquids and abrasive media whether in a dry or water borne. These include fuels, oils, diesel, sea water, drill water, water, mud pump, chemicals, dry powders, sand, animal feed, grain, flour, cement, gravel, barytes etc.

Hoses used at dockside or ship to ship often are often specified to BS EN1765: 2004 for the transfer of all grades of petroleum products including crude oils and other liquid petroleum products with a maximum aromatics content of 40%. For higher aromatic content up to 100% Viton® is available.

A wide range of rubber compounds, hose constructions, cover types/fishes terminations, couplings and hose & coupling security is available.



F

BULKSTREAM A160HW Series Multipurpose Suction & Delivery Hose

'Hard wall' corrugated cover, smooth bore suction & delivery hose, with helical supporting wire.

- Application:** Fuels, oils, diesel, sea water, mud, chemicals, dry powders, grains, flour, cement, sand, gravel, barytes.
- Liner & cover:** Smooth with polymer selection as appropriate to duty.
- Reinforcement:** Multiple layers of synthetic cord and fully rubber embedded and encapsulated high tensile steel wire helix.
- End Terminations:** Hose is supplied without fittings or assembled with built in/vulcanised carbon steel nipples with slip-on welded or welded neck flanges as required. Alternatively swaged full bore fittings are available as are other fitting types in a range of metals alloys and finishes/coatings.

TYPE	BORE SIZE RANGE (ALL TYPES)	PRESSURE (POSITIVE)	SAFETY FACTOR (MINIMUM)	VACUUM (NEGATIVE)	BEND RADIUS (WHEN PRESSURISED)	MANDREL LENGTHS
A165	51mm, 76mm, 102mm, 127mm, 152mm, 178mm, 203mm, 254mm, 305mm, 356mm, 406mm, 457mm, 508mm, 610mm, 914mm, 1000mm	3.5 bar	3.5:1	0.85 bar	6 x bore	40m maximum depending on bore size
A166		7 bar				
A167		10 bar				
A168		15 bar				
A169		20 bar				

Temperature range: dependant on rubbers/polymers appropriate to construction. All assemblies are proof pressure tested to 1.5 x working pressure.

FOR INSTALLATION AND SAFETY GUIDELINES REFER TO THE TECHNICAL SECTION



BULKSTREAM A170SW Series Multipurpose Delivery Hose

'Soft wall' smooth cover and bore delivery hose, without helical supporting wire.

Application: Fuels, oils, diesel, sea water, mud, chemicals, dry powders, grains, flour, cement, sand, gravel, barytes.

Liner & cover: Smooth with polymer selection as appropriate to duty.

Reinforcement: Multiple layers of synthetic cord.

End Terminations: Hose is supplied without fittings or assembled with built in/vulcanised carbon steel nipples with slip-on welded or welded neck flanges as required. Alternatively swaged full bore fittings are available as are other fitting types in a range of metals alloys and finishes/coatings.

TYPE	BORE SIZE RANGE (ALL TYPES)	PRESSURE (POSITIVE)	SAFETY FACTOR (MINIMUM)	BEND RADIUS (WHEN PRESSURISED)	MANDREL LENGTHS
A170	51mm, 76mm, 102mm, 127mm,	3.5 bar	3.5:1	8 x bore	Up to and including 305mm bore = 20m Larger bore sizes = 12m
A171	152mm, 178mm, 203mm, 254mm,	7 bar			
A172	305mm, 356mm, 406mm, 457mm,	10 bar			
A173	508mm, 610mm,	15 bar			

Temperature range: dependant on rubbers/polymers appropriate to construction. All assemblies are proof pressure tested to 1.5 x working pressure.

FOR INSTALLATION AND SAFETY GUIDELINES REFER TO THE TECHNICAL SECTION

BULKSTREAM A600HW Series Oil Suction & Delivery Hose

'Hard wall' smooth cover and bore suction & delivery hose, with helical supporting wire.

Construction to BS EN 1765:2004 (formerly BS 1435: Part 1:1987) Types S7, S10 & S15.

- Application:** Conveying a wide range of petroleum products, including crude oils and other liquid petroleum products in medium and heavy duty oil loading and un-loading duties on dockside, ship to shore or ship to ship.
- Liner:** Smooth black nitrile for aromatics up to a maximum of 40%. For 100% aromatics Viton® is available.
- Reinforcement:** Single ply breaker fabric to reinforce the lining with multiple plies of synthetic cord fabric surrounding a fully rubber embedded and encapsulated high tensile steel wire helix. As standard hose is electrically continuous through multiple copper coated steel wires secured to the end fittings, unless otherwise stated.
- Cover:** Smooth black neoprene resistant to oil, weathering and abrasion. A single ply of heavy gauge breaker fabric between the cover and main carcass bonds them securely together. For submarine duty a double cover and galvanised fittings are supplied as standard.
- End Terminations:** Hose is generally supplied assembled with built in vulcanised carbon steel nipples with slip-on welded or welded neck flanges as required. Alternatively swaged full bore fittings are available as are other fitting types in a range of metals alloys and finishes/coatings.

TYPE	BORE SIZE RANGE (ALL TYPES)	PRESSURE (POSITIVE)	SAFETY FACTOR (MINIMUM)	VACUUM (NEGATIVE)	BEND RADIUS (WHEN PRESSURISED)	MANDREL LENGTHS
A600	51mm, 76mm, 102mm, 127mm,	7 bar	6:1	0.85 bar	As per EN 1765:2004	Up to and including 305mm bore = 20m Larger bore sizes = 12m
A601	152mm, 178mm, 203mm, 254mm, 305mm, 356mm,	10 bar				
A602	406mm, 457mm, 508mm	15 bar				

Temperature range: -20°C to + 82°C. All assemblies are proof pressure tested to 1.5 x working pressure.

FOR INSTALLATION AND SAFETY GUIDELINES REFER TO THE TECHNICAL SECTION



BULKSTREAM A600SW Series Oil Delivery Hose

'Soft wall' smooth cover and bore suction & delivery hose, without helical supporting wire.

Construction to BS EN 1765:2004 (formerly BS 1435: Part 1:1987) Types L10 & L15.

- Application:** Conveying a wide range of petroleum products, including crude oils and other liquid petroleum products in medium and heavy duty oil loading and un-loading duties on dockside, ship to shore or ship to ship.
- Liner:** Smooth black nitrile for aromatics up to a maximum of 40%. For 100% aromatics Viton® is available.
- Reinforcement:** Single ply breaker fabric to reinforce the lining with multiple plies of synthetic cord fabric. As standard hose is electrically continuous through multiple copper coated steel wires secured to the end fittings, unless otherwise stated.
- Cover:** Smooth black neoprene resistant to oil, weathering and abrasion. A single ply of heavy gauge breaker fabric between the cover and main carcass bonds them securely together.
- End Terminations:** Hose is generally supplied assembled with built in/vulcanised carbon steel nipples with slip-on welded or welded neck flanges as required. Alternatively swaged full bore fittings are available as are other fitting types in a range of metals alloys and finishes/coatings.

F

TYPE	BORE SIZE RANGE (ALL TYPES)	PRESSURE (POSITIVE)	SAFETY FACTOR (MINIMUM)	BEND RADIUS (WHEN PRESSURISED)	MANDREL LENGTHS
A611	51mm, 76mm, 102mm, 127mm, 152mm, 178mm, 203mm, 254mm, 305mm	10 bar	6:1	6 x bore	Up to and including 305mm bore = 20m
A612		15 bar			

Temperature range: -20°C to + 82°C. All assemblies are proof pressure tested to 1.5 x working pressure.

FOR INSTALLATION AND SAFETY GUIDELINES REFER TO THE TECHNICAL SECTION

Rubber & Polymer Types

COMMON NAME	ASTM DESIGNATION	COMPOSITION	GENERAL PURPOSE
Neoprene	CR	Chloroprene	Good weathering resistance. Flame retarding. Good resistance to petroleum based fluids. Good physical properties.
Natural Rubber	NR	Isoprene natural	Excellent physical properties including abrasion and low temperature resistance. Poor resistance to petroleum based fluids.
Polyisoprene	IR	Isoprene synthetic	Excellent physical properties including abrasion and low temperature resistance. Poor resistance to petroleum based fluids.
Butyl	IIR	Isobutylene/ isoprene	Very good weathering resistance. Low permeability to air. Good physical properties. Poor resistance to petroleum based fluids.
Chlorobutyl	CIIR	Cloro-isobutene- isoprene	Very good weathering resistance. Low permeability to air. Good physical properties. Poor resistance to petroleum based fluids.
Nitrile	NBR	Nitrile butadiene	Excellent resistance to petroleum based fluids. Moderate resistance to aromatics. Good physical properties.
SBR	SBR	Styrene butadiene	Good physical properties including abrasion resistance. Poor resistance to petroleum based fluids.
Hypalon®	CSM	Chlorosulphonated polyethylene	Excellent ozone, weathering and acid resistance. Good heat and abrasion resistance. Fair resistance to petroleum based fluids.
Ethylene Propylene Rubber	EPDM	Ethylene-propylene-diene-terpolymer	Excellent ozone, chemical, heat and ageing characteristics. Poor resistance to petroleum based fluids.
Viton®	FKM	Fluoroelastomer	Excellent resistance to heat and aggressive fuels. Depending on grade also has excellent resistance to chemicals and good mechanical properties.
XLP	XLPE	Cross linked polyethylene	Extremely good resistance to chemicals. Temperature limitations.
UPE	UHMWPE	Ultra high molecular weight polyethylene	Extremely good resistance to chemicals. Suitable for use with edible produce. Temperature limitations.
Water Research Council Approved EPDM	WRCA	Ethylene propylene diene terpolymer	Material approved by the Water Research Council as fit for purpose in transferring potable water. Cadmium and silicone free, no odour or taint and will not support microbiological growth.

F

Methods of Attachment, Depending on Pressure

- Vulcanised and built in
- Swaged (External crimp EC, Internal expansion IX)
- Integral rubber and fabric flanges with steel backing plates
- Beaded ends
- Wired in
- Clamps
- Band-It strapping systems
- Viton® and Hypalon® are registered trademarks or trademarks of E.I. duPont de Nemours and Company or it's affiliates

FOR INSTALLATION AND SAFETY GUIDELINES REFER TO THE TECHNICAL SECTION



Flexible Convoluted & Smooth Bore PTFE Hose & Hose Assemblies



The Dixon range of smooth and convoluted PTFE hose and hose assemblies are available from 1/4 inch through to 1 inch and 3/8 inch to 4 inch respectively.

San-Flon Hose is available as virgin convoluted or smooth bore PTFE or with a covering. A range of outer coverings including metallic, glass fibre and polymer braid are available. Bounce Ring Protectors and Spiral Guards can be fitted.

All hoses are tested 150 p.s.i air under water and can be supplied with a wide range of certification if required. This must be specified at the time of enquiry or order.

We can also make your specialist requirements such as heat traced and duplex assemblies.

Antistatic liners are available for when electrically resistive fluids are being transferred at high flow rates.

Standard End Connections

F



All hoses are tested 150 p.s.i air under water and can be supplied with a wide range of certification if required. Assemblies are available with a wide range of end fittings.

SAN-FLON™ STAINLESS STEEL OVERBRAIDED CONVOLUTED PTFE HOSE

PART NO.	NOM ID		TOLERANCE		WALL THICKNESS		NOM.OD		MIN. BEND		RADIUS		MAX. WORKING PRESSURE		MAX. BURST PRESSURE	
	mm	inch	mm	inch	mm	inch	mm	inch	mm	inch	mm	inch	bar	psi	bar	psi
CP0.375	7.10	0.280	0.50	0.020	0.76	0.030	12.30	0.484	0.50	0.020	18	0.709	2500	172	7500	517
CP0.5	9.50	0.374	0.60	0.024	0.76	0.030	15.25	0.600	0.60	0.024	20	0.787	2000	138	6000	414
CP0.75	15.88	0.625	0.60	0.024	0.89	0.035	22.10	0.870	0.60	0.024	51	2.008	1200	83	3600	248
CP1	22.35	0.880	0.80	0.031	0.89	0.035	28.70	1.130	0.80	0.031	76	2.992	830	57	2500	172

Note: Polymer braid pressure ratings on application. Anti-Static PTFE hose assemblies also available.

SAN-FLON™ STAINLESS STEEL OVERBRAIDED SMOOTH BORE PTFE HOSE

PART NO.	NOM ID		TOLERANCE		WALL THICKNESS		NOM.OD		MIN. BEND		RADIUS		MAX. WORKING PRESSURE		MAX. BURST PRESSURE	
	mm	inch	mm	inch	mm	inch	mm	inch	mm	inch	mm	inch	bar	psi	bar	psi
SBP0.25	6.22	0.245	0.40	0.016	0.64	0.025	8.64	0.340	.060	0.024	76	2.992	3495	241	10498	724
SBP0.375	8.94	0.352	0.40	0.016	0.64	0.025	13.21	0.520	0.60	0.024	127	5.000	3176	219	9498	655
SBP0.5	12.37	0.487	0.40	0.016	0.76	0.030	15.40	0.606	0.60	0.024	140	5.512	2335	161	7004	483
SBP0.75	18.90	0.744	0.60	0.024	0.89	0.035	22.10	0.870	0.85	0.033	203	7.992	1653	114	5003	345
SBP1	25.40	1.000	0.80	0.031	1.10	0.043	29.75	1.171	1.20	0.047	305	12.008	1001	69	3002	207

Note: Polymer braid pressure ratings on application. Anti-Static PTFE hose assemblies also available.

LARGER BORE SIZES AVAILABLE

FOR INSTALLATION AND SAFETY GUIDELINES REFER TO THE TECHNICAL SECTION

Adflex Metal Hose



Description:	Corrugated flexible metal hose assembly meeting the requirements of class 1 of the EN ISO 10380 standard.		
Corrugated hose:	AISI: 321	DIN: 1.4541	EN: X6 Cr Ni Ti 18-10,
	AISI: 316L	DIN: 1.4404	EN: X2 Cr Ni Mo 17-12-2
Braid:	AISI: 304	DIN: 1.4031	EN: X5 Cr Ni 18-10

ADFLEX FLEXIBLE METALLIC HOSE

NOM. ID	MAX. O.D. (MM)		DYNAMIC BEND RADIUS (MM)	STATIC BEND RADIUS (MM)	WORKING PRESSURE (BAR)	
	WITHOUT BRAID	WITH ONE BRAID			WITHOUT BRAID	WITH ONE BRAID
DN 6	12.2	13.4	100	25	4	100
DN 10	15.8	17.0	150	40	4	90
DN 12	17.5	18.7	200	50	3	80
DN 15	22.0	23.2	200	50	2	64
DN 20	26.3	27.5	200	70	2	64
DN 25	33.8	35.3	200	90	2	50
DN 32	42.0	43.6	250	110	1.5	40
DN 40	51.6	53.2	250	130	1.5	30
DN 50	61.7	63.3	350	175	1	28
DN 65	77.0	79.0	410	200	1	24
DN 80	91.0	93.0	450	205	1	18
DN 100	117.5	119.5	560	230	0.8	16
DN 125	149.0	151.0	660	280	0.6	12
DN 150	178.0	180.0	815	320	0.6	10
DN 200	228.0	230.4	1015	435	0.5	8
DN 250	278.0	280.4	1220	560	0.5	6
DN 300	333.0	335.8	1420	660	0.3	5

Dimensions ID/OD Tolerance +/- 1.0mm

De-rating factors may apply for elevated temperature applications

Due to the continuous development of the products contained herein, dimensions are subject to change without prior notice.

FOR INSTALLATION AND SAFETY GUIDELINES REFER TO THE TECHNICAL SECTION



Suparflex Metallic Hose

Description: Parnor corrugated flexible metal hose assembly with close pitch annular corrugations, obtained by hydroforming Flexible hose meeting the requirement of the class 1 of the EN-ISO-10380 standard

Corrugated hose: AISI: 316L DIN: 1.4404 EN: X2 Cr Ni Mo 17-12-2

AISI: 321 DIN: 1.4541 EN: X6 Cr Ni Ti 18-10

Braid: AISI: 304 DIN: 1.4031 EN: X5 Cr Ni 18-10

SUPARFLEX FLEXIBLE METALLIC HOSE

NOM. ID	MAX. O.D. (MM)		DYNAMIC BEND RADIUS	STATIC BEND RADIUS	WORKING PRESSURE (BAR)	
	WITHOUT BRAID	WITH ONE BRAID	(MM)	(MM)	WITHOUT BRAID	WITH ONE BRAID
DN 6	9.8	11.4	110	23	18	140
DN 10	16.2	17.8	150	32	10	100
DN 12	18.6	20.2	165	39	12	80
DN 20	28.3	29.9	225	60	4.3	50
DN 25	34.8	36.4	260	73	3	40
DN 32	43.4	45.4	300	90	3.3	40
DN 40	52.4	54.4	340	115	2.2	32
DN 50	64.8	67.3	390	140	2.1	32
DN 65	80.9	83.4	460	175	1.3	25
DN 80	99.6	102.6	660	240	1.4	23
DN 100	126.5	129.5	750	290	0.5	15
DN 125	152.0	155.0	1000	340	0.4	13
DN 150	174.0	177.0	1250	390	0.3	11

Dimensions ID/OD Tolerance +/- 1.0mm

De-rating factors may apply for elevated temperature applications

Due to the continuous development of the products contained herein, dimensions are subject to change without prior notice.

FOR INSTALLATION AND SAFETY GUIDELINES REFER TO THE TECHNICAL SECTION

Hyparflex Metallic Hose

Description: Parrap corrugated flexible metal hose assembly with close pitch annular corrugations, obtained by hydroforming Flexible hose meeting the requirement of the class 1 of the EN-ISO-10380 standard

Corrugated hose: AISI: 316L DIN: 1.4404 EN: X2 Cr Ni Mo 17-12-2

AISI: 321 DIN: 1.4541 EN: X6 Cr Ni Ti 18-10

Braid: AISI: 304 DIN: 1.4301 EN: X5 Cr Ni 18-10

HYPARFLEX FLEXIBLE METALLIC HOSE						
NOM. ID	MAX. O.D. (MM)		DYNAMIC BEND RADIUS	STATIC BEND RADIUS	WORKING PRESSURE (BAR)	
	WITHOUT BRAID	WITH ONE BRAID	(MM)	(MM)	WITHOUT BRAID	WITH ONE BRAID
DN 6	9.8	11.4	110	20	18	150
DN 10	16.2	17.8	150	20	6	115
DN 12	18.6	20.2	124	25	6	80
DN 20	28.3	29.9	169	38	2.2	55
DN 25	34.8	36.4	195	45	1.8	40
DN 32	43.4	45.4	225	58	1.6	40
DN 40	52.4	54.4	225	70	1.2	32
DN 50	64.8	67.3	293	85	1	32
DN 65	80.9	83.4	345	105	0.5	25
DN 80	99.6	102.6	495	180	0.7	23
DN 100	126.5	129.5	563	218	0.4	15
DN 125	152.0	155.0	1000	255	0.25	13
DN 150	174.0	177.0	1250	290	0.2	11

Dimensions ID/OD Tolerance +/- 1.0mm

De-rating factors may apply for elevated temperature applications

Due to the continuous development of the products contained herein, dimensions are subject to change without prior notice.



FOR INSTALLATION AND SAFETY GUIDELINES REFER TO THE TECHNICAL SECTION



HP/THP Metallic Hose

Description: Corrugated flexible hose assembly, high pressure (HP-1 Braid) and very high pressure (TH-2 Braids) with close pitch annular corrugations, obtained by hydroforming.
Flexible hose meeting the requirement of the class 1 of the EN-ISO-10380 standard

Corrugated hose: AISI: 316L DIN: 1.4404 EN: X2 Cr Ni Mo 17-12-2
 AISI: 321 DIN: 1.4541 EN: X6 Cr Ni Ti 18-10

Braid: AISI: 304 DIN: 1.4031 EN: X5 Cr Ni 18-10

HP/THP FLEXIBLE METALLIC HOSE

NOM. ID	MAX. O.D. (MM)		DYNAMIC BEND RADIUS	STATIC BEND RADIUS	WORKING PRESSURE (BAR)	
	WITHOUT BRAID	WITH ONE BRAID	(MM)	(MM)	WITHOUT BRAID	WITH ONE BRAID
DN 6	11.4	13	110	25	180	255
DN 10	17.8	19.4	150	38	145	195
DN 12	20.2	21.8	165	45	140	185
DN 20	29.1	30.7	225	70	85	125
DN 25	38.0	40.0	260	85	78	124
DN 32	46.5	49.0	300	105	65	90
DN 40	54.9	57.4	340	130	61	90
DN 50	67.3	69.8	390	160	55	78
DN 100	129.5	132.5	750	290	24	45

Dimensions ID/OD Tolerance +/- 1.0mm

De-rating factors may apply for elevated temperature applications

Due to the continuous development of the products contained herein, dimensions are subject to change without prior notice.

FOR INSTALLATION AND SAFETY GUIDELINES REFER TO THE TECHNICAL SECTION

Hose - Specialty High Pressure, High Temperature & Armoured

For nearly a century, GSM hose has been the product by which all other flexible armoured hoses are measured. Whether carrying 22,000 SCFM of pure oxygen in an environment of extreme heat and pressure during the production of steel, or protecting a high pressure, rotary hose on a drilling rig, GSM remains the best choice for durability, safety and efficiency. Dixon Specialty Hose can assist in the careful selection of the correct GSM product to meet the rigors of nearly any hose application. Manufactured in Chestertown, MD in sizes ranging from ¼" through 10" bore and lengths to 100 ft., GSM protects internal hoses of rubber, all stainless steel or even PTFE. Each assembly is wrapped with multiple layers of insulation, resistant to 538°C, and then topped with the unique GSM Ball Joint Armour of either carbon steel or stainless steel.

GSM's distinctive half round ball joint design allows for multiple plane movements, and is virtually impossible to kink, creating the most forgiving flexible hose product available. All finished hoses are assembled by expertly trained factory professionals. Dixon Specialty Hose can couple, test, clean and certify to a multitude of special requirements. All hose assemblies are closely inspected, measured and verified for the intended service prior to crating and shipment.

GSM Hose Design and Critical Risk Factors

GSM hose not flexed

- dual half oval spirals
- galvanised steel/aluminium
- ball-joint, overlapping surfaces
- no interlocking or corrugations to inhibit flexing

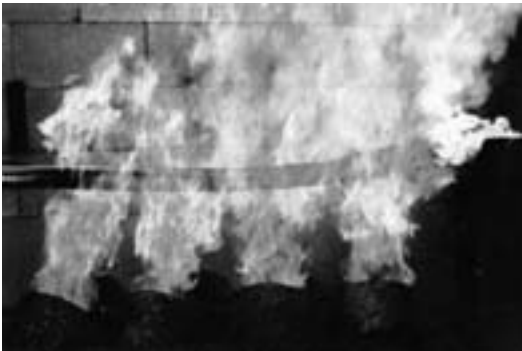

BOP hose tested at 1093°C, 2,000,000 BTU's at 5,000 PSIWP.

GSM FLEXED

- convex surfaces glide over each other
- inner hose will not kink or collapse
- superior bending radii
- multiple plane bending permitted

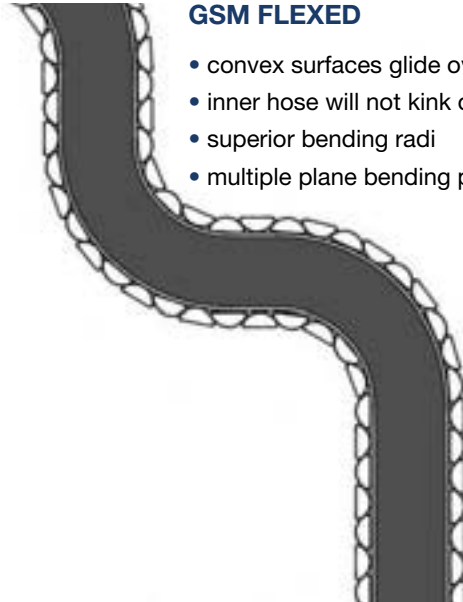

F

Insulation, composed of various layers, protects the assembly from external heat.



Inner hose is designed for material to be handled: steam, water, oxygen, chemicals, hydraulic fluids, etc. Tube is compatible with the medium being transferred.

Ball-joint armour of galvanised, stainless steel or aluminium offers resistance to external abuse, kinking and heat.

Working pressure of hose will be designed to meet application.

FOR INSTALLATION AND SAFETY GUIDELINES REFER TO THE TECHNICAL SECTION



Telephone: +44 (0)1772 323529

Fax: +44 (0)1772 314664

Water Hose

Application:	Water cooling applications and the transfer of water involving heat and external abrasion.
Specification:	350E.
Temperature:	Temperature rate depends on the specific application.
Tube:	$\frac{3}{8}$ " - 3" = nitrile blend / 4" - 10" SBR.
Reinforcement:	Combination of textile and metal reinforcement, 4" and above have metal helical wire.
Cover:	$\frac{3}{8}$ " - 3" = neoprene / 4" - 10" SBR.
Special Features:	Heat resistant insulation to 538°C and GSM Ball Joint Armour available in galvanised steel or stainless steel.



Oxygen Hose

F

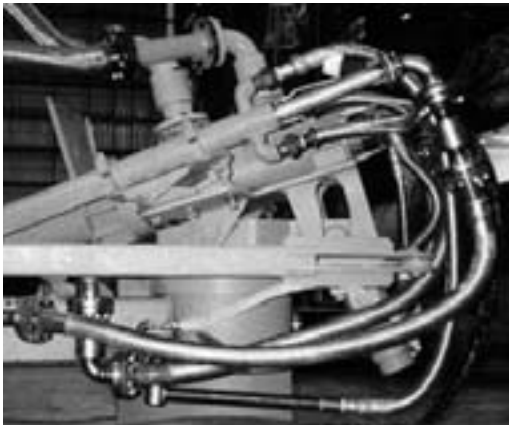

Application:	Oxygen service where heat and external abrasion are present.
Specification:	256E.
Temperature:	Temperature rate depends on the specific application.
Tube:	Neoprene.
Reinforcement:	Combination of textile and metal reinforcement, 4" and above have metal helical wire.
Cover:	Neoprene.
Special Features:	Heat resistant insulation to 538°C and GSM Ball Joint Armour available in galvanised steel or stainless steel.

BOF Oxygen Lance Hose



Application:	For the critical transfer of oxygen to the basic oxygen furnace.
Specification:	LW65.
Temperature:	Temperature rate depends on the specific application.
Tube:	Smooth bore-high quality neoprene.
Reinforcement:	Combination of textile and metal reinforcement, 4" and above have metal helical wire.
Cover:	Smooth neoprene.
Special Features:	Heat resistant insulation to 538°C and GSM Ball Joint Armour available in galvanised steel or stainless steel.

FOR INSTALLATION AND SAFETY GUIDELINES REFER TO THE TECHNICAL SECTION

Natural Gas Hose

- Application:** Natural gas systems, oxy-fuel burners. Used in applications to convey natural gas in areas of heat and abrasion.
- Specification:** 524E.
- Temperature:** Temperature rate depends on the specific application.
- Tube:** Neoprene.
- Reinforcement:** Combination of textile and metal reinforcement, 4" and above have metal helical wire.
- Cover:** Smooth neoprene.
- Special Features:** Heat resistant insulation to 538°C and GSM Ball Joint Armour available in galvanised steel or stainless steel.



Black Liquor Hose



- Application:** Black Liquor service used in application to convey Black Liquor in areas of heat and abrasion.
- Specification:** 800E.
- Temperature:** Rating at 232°C. Temperature rate depends on the specific application.
- Tube:** Butyl blend.
- Reinforcement:** Wire braid.
- Cover:** EPDM.
- Special Features:** Heat resistant insulation to 538°C and GSM Ball Joint Armour available in galvanised steel or stainless steel.

F

Hydraulic 100R12 & 100R13

- Application:** Hydraulic service used in application, used in areas of heat and abrasion.
- Specification:** 100R12XHRGSM.
- Temperature:** Temperature rate depends on the specific application.
- Tube:** Synthetic rubber.
- Reinforcement:** 4- wire braid.
- Cover:** Synthetic rubber.
- Special Features:** Heat resistant insulation to 538°C and GSM Ball Joint Armour available in galvanised steel or stainless steel.

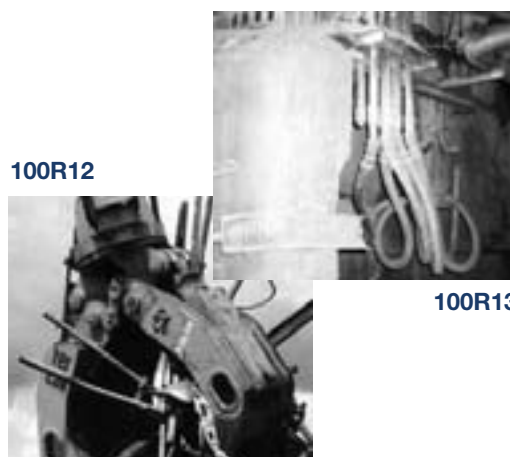

FOR INSTALLATION AND SAFETY GUIDELINES REFER TO THE TECHNICAL SECTION

Spiral Guard™ Flame Retardant Hose and Cable Protection



Provides heavy duty hose, cable or wire protection. Used in mining, quarrying, forestry, offshore industries and most hydraulic hose applications.

- Crush and high abrasion resistance
- Chemical and UV ray resistant
- Self-lubricating to reduce hose wear
- Easy to install on-site
- Smooth radius on all edges
- Can be used on single or multiple hose bundles

FLAME RETARDANT PRODUCT

PART NO.	SPIRAL GUARD I.D.*		COIL LENGTH (m)	1 WIRE	2 WIRE	MULTI SPIRAL HOSE
	(inches)	(mm)				
NFSGX16	1/2"	13	20	#4	#4	-
NFSGX20	5/8"	16	20	#6	#4	#6
NFSGX25	3/4"	19	20	#8	#8	#8
NFSGX32	15/16"	24	20	#12	#10	#12
NFSGX40	1 1/4"	32	20	#16	#16	#16
NFSGX50	1 1/2"	38	20	#20	#20	#20
NFSGX63	1 15/16"	49	20	#32	#24	#24
NFSGX75	2 3/8"	60	20	-	#32	#32
NFSGX90	2 5/8"	67	20	-	-	-
NFSGX110	3 3/16"	81	10	-	-	-

- Approved by MSHA 1C-231/1
- Flame retardant and self extinguishing
- Temperature Range: -148°F to 212°F, (-100°C to 100°C)

STANDARD PRODUCT

PART NO.	SPIRAL GUARD I.D.*		COIL LENGTH (m)	1 WIRE	2 WIRE	MULTI SPIRAL HOSE
	(inches)	(mm)				
NFSGX16	1/2"	13	20	#4	#4	-
NFSGX20	5/8"	16	20	#6	#4	#6
NFSGX25	3/4"	19	20	#8	#8	#8
NFSGX32	15/16"	24	20	#12	#10	#12
NFSGX40	1 1/4"	32	20	#16	#16	#16
NFSGX50	1 1/2"	38	20	#20	#20	#20
NFSGX63	1 15/16"	49	20	#32	#24	#24
NFSGX75	2 3/8"	60	20	-	#32	#32
NFSGX90	2 5/8"	67	20	-	-	-
NFSGX110	3 3/16"	81	10	-	-	-

- Not flame retardant
- Temperature Range: -58°F to 194°F, (-50°C to 90°C)

FOR INSTALLATION AND SAFETY GUIDELINES REFER TO THE TECHNICAL SECTION

Fire Jacket for Hose



Provides heavy duty hose, cable or wire protection. Used in mining, quarrying, forestry, offshore industries and most hydraulic hose applications.

- Crush and high abrasion resistance
- Chemical and UV ray resistant
- Self-lubricating to reduce hose wear
- Easy to install on-site
- Smooth radius on all edges
- Can be used on single or multiple hose bundles

FIRE JACKET		
PART NO.	NOMINAL I.D.	
	(inches)	(mm)
0610-4	1/4	6
1010-6	3/8	10
1310-8	1/2	13
1610-10	5/8	16
1910-12	3/4	19
2210-14	7/8	22
2510-16	1	25
3210-20	1 1/4	32
3810-24	1 1/2	38
4510-28	1 3/4	44
5110-32	2	51
6410-40	2 1/5	65
7610-48	3	76
10210-64	4	102

F

Dixon Diameter Tape



- 6' tape for quickly finding the outside diameter of any cylindrical object
- Converts circumference to O.D. at the measured point
- Metal case

DIAMETER TAPE	
PART NO.	
DDT1	

FOR INSTALLATION AND SAFETY GUIDELINES REFER TO THE TECHNICAL SECTION

Hygienic Products

Hygienic Introduction	140-142
RJT BS:4825	143-146
DIN 11851	147-150
IDF	151-154
SMS	155-158
Clamp Type	159-168
Bends, Tees & Reducers	169-172
UK Dairy Standard Fittings	173-174
High Purity BioPharm Fittings	175-178
Sight Glasses	179
Pipe Hangers	180
Hygienic Pressure Gauges	181
Spray Balls	182
Check Valves	183-187
Ball Valves	188-196
Butterfly Valves	197-202

Valve Automation	203-223
Seat Valves	224-225
Hygienic Centrifugal Pump.....	226
Hygienic Filters/Strainers.....	227-232
Sample Valves.....	233-235
Fabrication & Tubing	236-237



**FOR A FULL RANGE OF HYGIENIC HOSES
TO COMPLEMENT THESE FITTINGS SEE SECTION F**

Hygienic, Fittings, Valves & Hose Assemblies

We are pleased to offer our customers one of the most extensive ranges for Food, Beverage, Pharmaceutical and Fine Chemical applications.

- Fittings & Clamps
- Gauges
- Valves
- Actuation
- Custom Fabrication
- Hose Assemblies

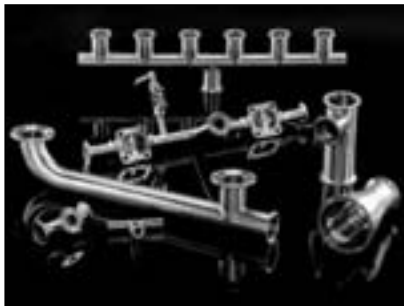

The Dixon range compliments the Holedall Hygienic and Sanbrew/Sanfood Hose range enabling us to offer a complete package of Fittings and Hose assemblies.

Whatever your requirement please call for the latest availability. Many items are available from stock or are made to order on very short lead times.

If you have special product or delivery requirements we have extensive design and manufacturing facilities which can be used to satisfy your requirements.

ELASTOMER AND THERMOPLASTIC CHARACTERISTICS

MATERIAL	BUNA	EPDM	VITON®	PTFE	SILICONE
Temperature	-50°C to 120°C	-48°C to 135°C	-30°C to 200°C	-35°C to 140°C	-35°C to 230°C
Acid	Good	Good to Excellent	Good to Excellent	Good to Excellent	Poor to Good
Alkali	Fair to Good	Good to Excellent	Poor to Good	Excellent	Poor to Fair
Fats/Oils	Good to Excellent	Poor*	Good to Excellent	Excellent	Poor to Good
Taste	Good	Good	Good	Excellent	Good
Odour	Good	Good	Good	Excellent	Good
Abrasion Resistance	Excellent	Good	Good	Fair	Good
Compression Set	Good	Fair	Good to Excellent	Cold Flows	Good to Excellent

Product Specifications

Size Range:	1/2" to 12" O.D.
Materials:	G-304 Stainless Steel. R-316L Stainless Steel.
Finish:	3A and UK Dairy as standard. Other finishes available.

Note: all non-wetted parts are in 304. Example hex nuts, clamps, pipe hangers, actuator castings.

FINISH DESIGNATIONS FOR TUBING AND FITTINGS

Finish Number	Finish Conditions
1	Mill Finish (bright annealed, pickled, sand blasted or tumbled).
3	w 180 grit inside diameter (ID) only.
5	Polished 150 grit outside diameter (OD) only. UK Dairy Standard.
7	Polished 180 grit outside / inside diameter (OD/ID).
3A	Polished 150 grit outside diameter (OD), 180 grit inside diameter (ID).

FINISH SPECIFICATIONS

Process	RA micro inches	RA microns	ISO Designation
150 grit	30 - 35	0.720 - 0.875	N4
150 grit & Electropolish	12 - 20	0.300 - 0.500	
180 grit	20 - 25	0.500 - 0.625	
180 grit & Electropolish	10 - 16	0.250 - 0.400	
240 grit	15 - 20	0.375 - 0.500	N5
240 grit & Electropolish	8 - 12	0.200 - 0.300	
340 grit	8 - 12	0.200 - 0.300	N6
340 grit & Electropolish	6 - 12	0.150 - 0.300	

Note: Additional Improvements to the surface finish require buffing and further electropolishing.

The effect is to improve the existing surface by about 50%.

Ordering Information and Part Numbers.

Please refer to the specific product page.

Specify quantity, Size (1/2" to 12 inch, equates 50 to 1200 in our part number system.)

Specify Material either 304 (**G**) or 316L (**R**) Stainless Steel.

Examples: 5 off, RJT **1 inch** Hex Nuts in 304 Stainless Steel: Part number 13H-**G100**RJT.

10 off, IDF **3 inch** Weld Liner in 316 Stainless Steel: Part number 14A-**R300**IDF.

European Connections

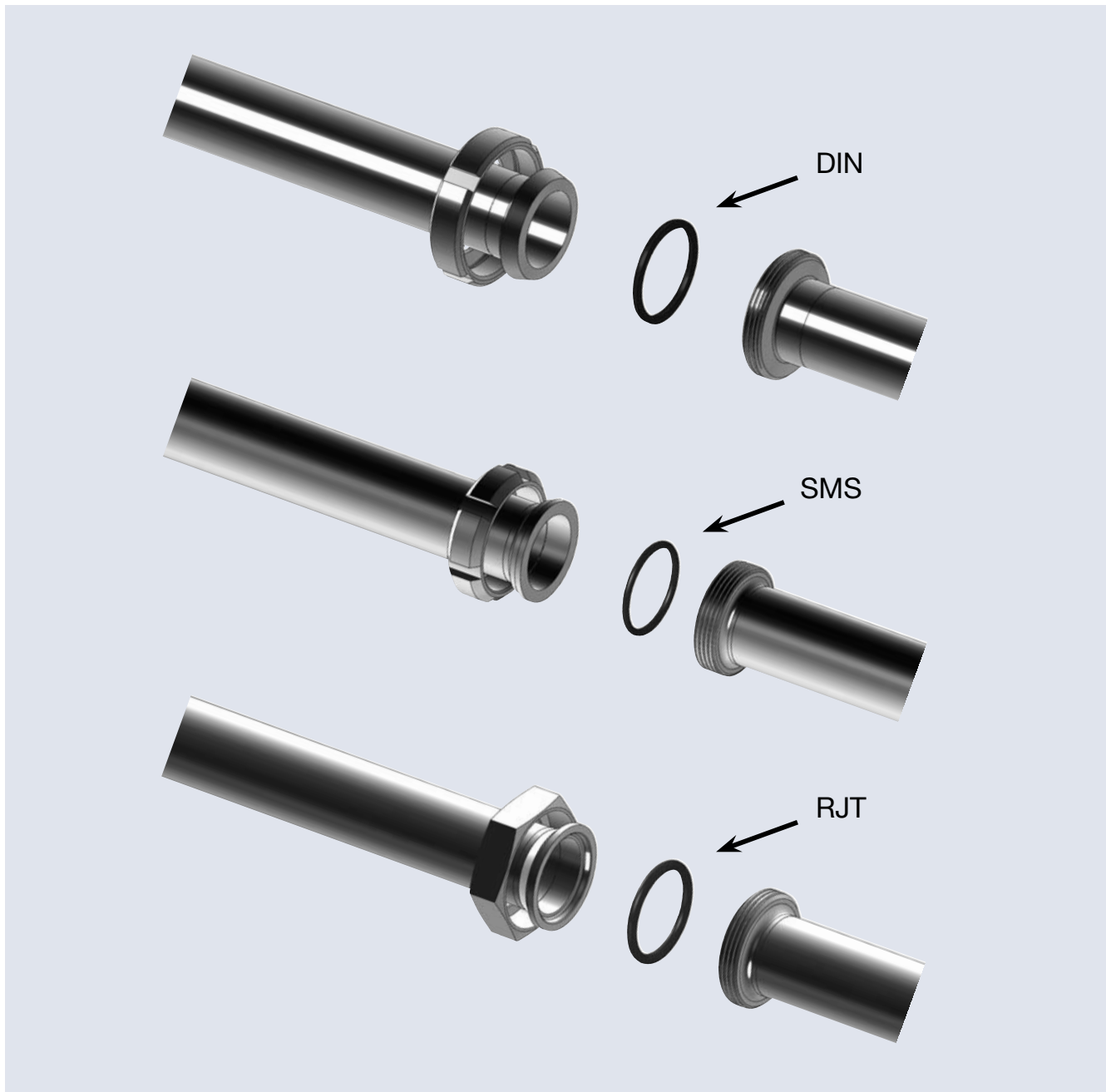

G

Product Specifications

Size range: • 1" - 4" OD

Materials: • G = 304 stainless steel
• R = 316 stainless steel

Finish: • 3A sanitary finish ID and OD

RJT BS:4825

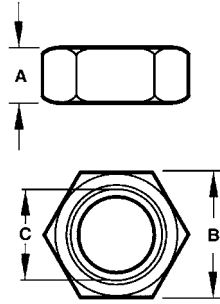

RJT HEX NUT RJT-13H				
PART NO.	SIZE	A (mm)	B (mm)	C (mm)
13H-G100RJT	1"	22.20	50.8	42.6* 8T
13H-G150RJT	1 1/2"	22.20	65.0	55.3* 6T
13H-G200RJT	2"	22.20	79.3	68.3* 6T
13H-G250RJT	2 1/2"	22.20	92.0	80.9* 6T
13H-G300RJT	3"	22.20	104.7	93.6* 6T
13H-G400RJT	4"	22.20	130.0	119.1* 6T

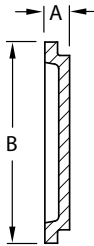

RJT BLANK CAP - 13RBN	
PART NO.	SIZE
13RBN-G100RJT	1"
13RBN-G150RJT	1 1/2"
13RBN-G200RJT	2"
13RBN-G250RJT	2 1/2"
13RBN-G300RJT	3"
13RBN-G400RJT	4"

Please note: Blanks can only be used with a matching nut



RJT HEX BLANK NUT WITH CHAIN -13HBN	
PART NO.	SIZE
13HBN-G100RJT	1"
13HBN-G150RJT	1 1/2"
13HBN-G200RJT	2"
13HBN-G250RJT	2 1/2"
13HBN-G300RJT	3"
13HBN-G400RJT	4"

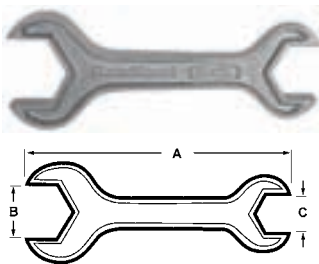

EXCLUSIVE

RJT DOUBLE ENDED SPANNER				
PART NO.	SIZE	A	B	C
RJT-150100SP	1 1/2" x 1"	305	65	50.8
RJT-200150SP	2" x 1 1/2"	356	79.3	65
RJT-250200SP	2 1/2" x 2"	419	92	79.3

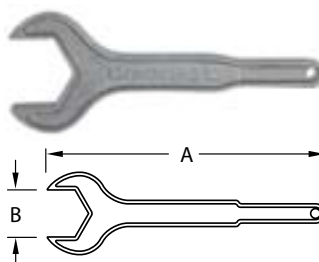

RJT SPANNER			
PART NO.	SIZE	A	B
RJT-100SP	1"	2.00	10.5
RJT-150SP	1 1/2"	2.56	12.0
RJT-200SP	2"	3.12	14.0
RJT-250SP	2 1/2"	3.62	16.3
RJT-300SP	3"	4.12	18.5
RJT-400SP	4"	5.12	19.5

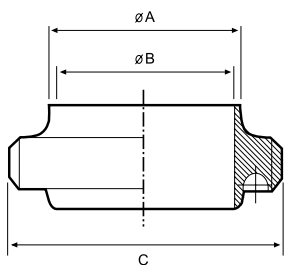

RJT WELDING MALE RJT-15

PART NO.	SIZE	A (mm)	B (mm)	C (mm)
15A-R100RJT	1"	25.65	22.20	45.72
15A-R150RJT	1 1/2"	38.35	34.90	58.42
15A-R200RJT	2"	51.05	47.60	72.72
15A-R250RJT	2 1/2"	63.75	60.30	85.42
15A-R300RJT	3"	76.45	73.00	98.12
15A-R400RJT	4"	101.85	97.60	123.52

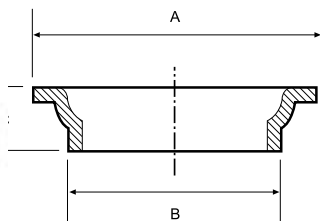

RJT PRESSED LINER

PART NO.	SIZE	A (mm)	B (mm)	C (mm)
H1RJTL	1"	41.3	32.5	12.7
H1.5RJTL	1 1/2"	54.0	45.2	12.7
H2RJTL	2"	66.7	58.0	12.7
H2.5RJTL	2 1/2"	79.4	70.6	12.7
H3RJTL	3"	92.1	83.5	12.7
H4RJTL	4"	117.5	108.3	12.7

G

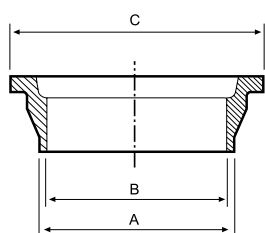

RJT WELDING LINER RJT-14

PART NO.	SIZE	A (mm)	B (mm)	C (mm)
14A-R100RJT	1"	25.65	22.20	41.30
14A-R150RJT	1 1/2"	38.35	34.90	54.00
14A-R200RJT	2"	51.05	47.60	66.70
14A-R250RJT	2 1/2"	63.75	60.30	79.40
14A-R300RJT	3"	76.45	73.00	92.10
14A-R400RJT	4"	101.85	97.60	117.50

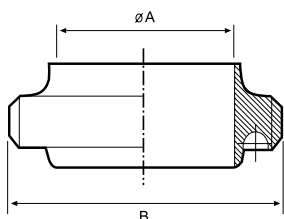

RJT EXPANDING MALE 15R

PART NO.	SIZE	A (mm)	B (mm)
15R-R100RJT	1"	22.20	45.72 * 8TPI
15R-R150RJT	1 1/2"	34.90	58.42 * 8TPI
15R-R200RJT	2"	47.60	78.72 * 6TPI
15R-R250RJT	2 1/2"	60.30	85.42 * 6TPI
15R-R250RJT	3"	73.00	98.12 * 6TPI
15R-R400RJT	4"	97.60	123.52 * 6TPI

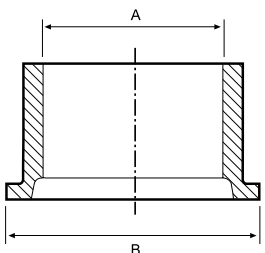

RJT EXPANDING LINER 14R

PART NO.	SIZE	A (mm)	B (mm)
14R-R100RJT	1"	22.20	41.30
14R-R150RJT	1 1/2"	34.90	54.00
14R-R200RJT	2"	47.60	66.70
14R-R250RJT	2 1/2"	60.30	79.40
14R-R300RJT	3"	73.00	92.10
14R-R400RJT	4"	97.60	117.50



HOLEDALL® RJT EXTERNAL CRIMP STEM	
PART NO.	SIZE
FEMALE	
HA0224	1"
HA0225	1½"
HA0226	2"
HA0227	2½"
HA0228	3"
HA0294	4"
MALE	
HA0219	1"
HA0220	1½"
HA0221	2"
HA0222	2½"
HA0223	3"
HA0293	4"

Please note: All stems are manufactured to suit inch bore hoses (not metric hose bores).



HOLEDALL® RJT EXTERNAL CRIMP FERRULES			
PART NO.	SIZE	HOSE OD RANGE (mm)	
		From	To
F16G-1453	1"	35.7	36.5
F16G-1500	1"	36.9	37.7
F16G-1547	1"	38.1	38.9
F16G-1594	1"	39.3	40.1
F16G-1641	1"	40.5	41.3
F24G-1969	1½"	48.4	49.6
F24G-2031	1½"	50.0	51.2
F24G-2094	1½"	51.6	52.8
F24G-2156	1½"	53.2	54.4
F32G-2531	2"	62.7	63.9
F32G-2594	2"	64.3	65.5
F32G-2656	2"	65.9	67.1
F32G-2719	2"	67.4	68.7
F40G-3070	2½"	76.1	78.1
F40G-3150	2½"	78.1	80.1
F40G-3268	2½"	81.1	83.1
F48G-3525	3"	91.7	92.9
F48G-3688	3"	92.1	93.3
F48G-3750	3"	93.6	94.9
F48G-3813	3"	95.2	96.5
F48G-3875	3"	96.8	98.0
F48G-3938	3"	98.4	99.6
F64G-3625	4"	117.5	118.7
F64G-4750	4"	119.0	120.3
F64G-4813	4"	120.6	121.9
F64G-4875	4"	122.2	123.5
F64G-4938	4"	123.8	125.0

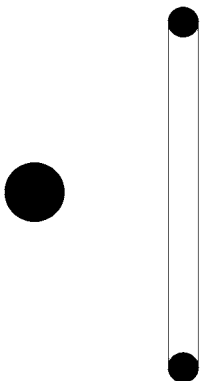

RJT O-RING / SILICONE			
PART NO.	SIZE	ID	OD
40MP-XW100RJT	1"	30	33.30
40MP-XW150RJT	1 1/2"	39.40	46.00
40MP-XW200RJT	2"	55.50	62.10
40MP-XW250RJT	2 1/2"	68.10	74.70
40MP-XW300RJT	3"	80.80	78.40
40MP-XW400RJT	4"	97.20	103.80

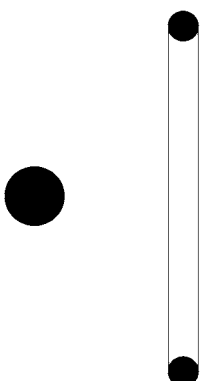

RJT O-RING / EPDM			
PART NO.	SIZE	ID	OD
40MP-E100RJT	1"	30	33.30
40MP-E150RJT	1 1/2"	39.40	46.00
40MP-E200RJT	2"	55.50	62.10
40MP-E250RJT	2 1/2"	68.10	74.70
40MP-E300RJT	3"	80.80	78.40
40MP-E400RJT	4"	97.20	103.80

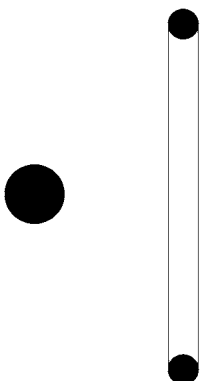

RJT O-RING / VITON®			
PART NO.	SIZE	ID	OD
40MP-SFY100RJT	1"	30	33.30
40MP-SFY150RJT	1 1/2"	39.40	46.00
40MP-SFY200RJT	2"	55.50	62.10
40MP-SFY250RJT	2 1/2"	68.10	74.70
40MP-SFY300RJT	3"	80.80	78.40
40MP-SFY400RJT	4"	97.20	103.80

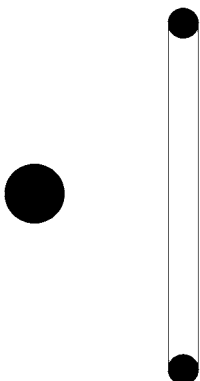

RJT O-RING / BUNA			
PART NO.	SIZE	ID	OD
40MP-U100RJT	1"	30	33.30
40MP-U150RJT	1 1/2"	39.40	46.00
40MP-U200RJT	2"	55.50	62.10
40MP-U250RJT	2 1/2"	68.10	74.70
40MP-U300RJT	3"	80.80	78.40
40MP-U400RJT	4"	97.20	103.80

PLEASE CALL FOR ALL YOUR OTHER RJT REQUIREMENTS. MANY OTHER PARTS AVAILABLE.

DIN 11851/11887, Couplings and Gaskets

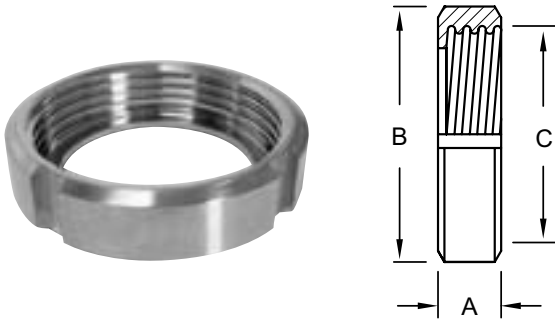

DIN ROUND NUT 11851 4 SLOTS				
PART NO.	SIZE	A (mm)	B (mm)	C (mm)
13R-G100DIN	DN25	63	52 x 1/6	21
13R-G150DIN	DN40	78	65 x 1/6	21
13R-G200DIN	DN50	92	78 x 1/6	22
13R-G250DIN	DN65	112	95 x 1/6	25
13R-G300DIN	DN80	127	110 x 1/4	30
13R-G400DIN	DN100	148	130 x 1/4	31

Please note: for sizes of 2.5" and over this nut has 6 slots



DIN BLANK	
PART NO.	SIZE
16AMP-R100DIN	DN25
16AMP-R150DIN	DN40
16AMP-R200DIN	DN50
16AMP-R250DIN	DN65
16AMP-R300DIN	DN80
16AMP-R400DIN	DN100

Please note: Blanks can only be used with a matching nut.

G



DIN BLANK NUT WITH CHAIN	
PART NO.	SIZE
13RBN-G100DIN	DN25
13RBN-G150DIN	DN40
13RBN-G200DIN	DN50
13RBN-G250DIN	DN65
13RBN-G300DIN	DN80
13RBN-G400DIN	DN100

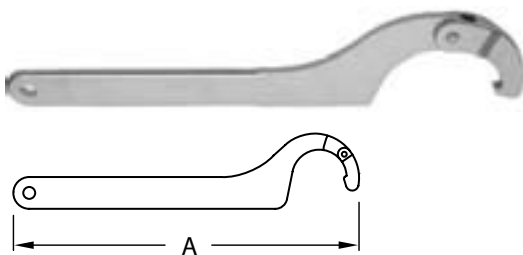

DIN SPANNER		
PART NO.	SIZE	A
DIN-SMS-60/90SP	1" - 1 1/2"	11.00
DIN-SMS-90/155SP	2" - 4"	13.00

For use on DIN or SMS Rounded Nuts.

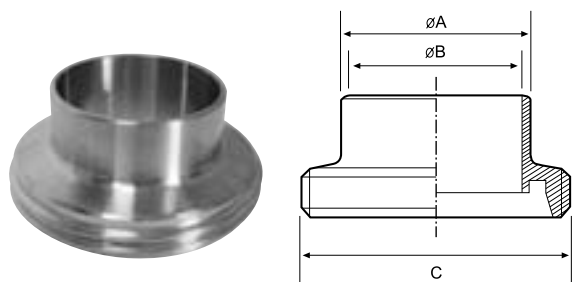

DIN WELD IMPERIAL				
PART NO.	SIZE	A (mm)	B (mm)	C (mm)
15A-R100DIN	DN25	25.4	22.1	52 x 1/6
15A-R150DIN	DN40	38.1	34.8	65 x 1/6
15A-R200DIN	DN50	50.8	47.5	78 x 1/6
15A-R250DIN	DN65	63.5	60.2	95 x 1/6
15A-R300DIN	DN80	76.2	72.9	110 x 1/4
15A-R400DIN	DN100	101.6	97.6	130 x 1/4

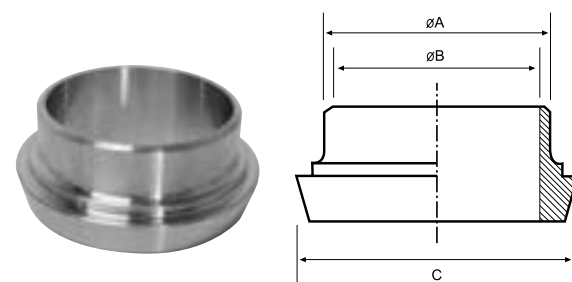

DIN WELD LINER IMPERIAL				
PART NO.	SIZE	A (mm)	B (mm)	C (mm)
14A-R100DIN	DN25	25.4	22.1	44
14A-R150DIN	DN40	38.1	34.8	56
14A-R200DIN	DN50	50.8	47.5	68
14A-R250DIN	DN65	63.5	60.2	86
14A-R300DIN	DN80	76.2	72.9	100
14A-R400DIN	DN100	101.6	97.6	121

G

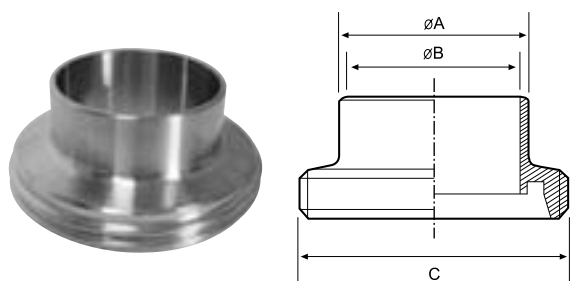

DIN WELD MALE METRIC				
PART NO.	SIZE	A (mm)	B (mm)	C (mm)
15A-R100DINM	DN25	29	26	52 x 1/6
15A-R150DINM	DN40	41	38	65 x 1/6
15A-R200DINM	DN50	53	50	78 x 1/6
15A-R250DINM	DN65	70	66	95 x 1/6
15A-R300DINM	DN80	85	81	110 x 1/4
15A-R400DINM	DN100	104	100	130 x 1/4

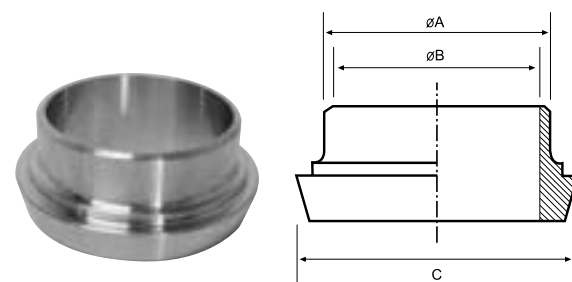

DIN WELD LINER METRIC				
PART NO.	SIZE	A (mm)	B (mm)	C (mm)
14A-R100DINM	DN25	29	26	44
14A-R150DINM	DN40	41	38	56
14A-R200DINM	DN50	53	50	68
14A-R250DINM	DN65	70	66	86
14A-R300DINM	DN80	85	81	100
14A-R400DINM	DN100	104	100	121



HOLEDALL® DIN EXTERNAL CRIMP STEM	
PART NO.	SIZE
FEMALE	
HA0239	DN25
HA0240	DN40
HA0241	DN50
HA0242	DN65
HA0243	DN80
HA0298	DN100
MALE	
HA0234	DN25
HA0235	DN40
HA0236	DN50
HA0237	DN65
HA0238	DN80
HA0297	DN100

Please note: All stems are manufactured to suit inch bore hoses (not metric hose bores).



HOLEDALL® DIN EXTERNAL CRIMP FERRULES			
PART NO.	SIZE	HOSE OD RANGE (mm)	
		From	To
F16G-1453	DN25	35.7	36.5
F16G-1500	DN25	36.9	37.7
F16G-1547	DN25	38.1	38.9
F16G-1594	DN25	39.3	40.1
F16G-1641	DN25	40.5	41.3
F24G-1969	DN40	48.4	49.6
F24G-2031	DN40	50.0	51.2
F24G-2094	DN40	51.6	52.8
F24G-2156	DN40	53.2	54.4
F32G-2531	DN50	62.7	63.9
F32G-2594	DN50	64.3	65.5
F32G-2656	DN50	65.9	67.1
F32G-2719	DN50	67.4	68.7
F40G-3070	DN65	76.1	78.1
F40G-3150	DN65	78.1	80.1
F40G-3268	DN65	81.1	83.1
F48G-3525	DN80	91.7	92.9
F48G-3688	DN80	92.1	93.3
F48G-3750	DN80	93.6	94.9
F48G-3813	DN80	95.2	96.5
F48G-3875	DN80	96.8	98.0
F48G-3938	DN80	98.4	99.6
F64G-3625	DN100	117.5	118.7
F64G-4750	DN100	119.0	120.3
F64G-4813	DN100	120.6	121.9
F64G-4875	DN100	122.2	123.5
F64G-4938	DN100	123.8	125.0



GASKET FOR DIN / SILICONE			
PART NO.	SIZE	ID	OD
40MP-S20MDIN	DN20	23	33
40MP-S25MDIN	DN25	30	40
40MP-S32MDIN	DN32	36	46
40MP-S40MDIN	DN40	42	52
40MP-S50MDIN	DN50	54	64
40MP-S65MDIN	DN65	71	81
40MP-S80MDIN	DN80	85	95
40MP-S100MDIN	DN100	104	114



GASKET FOR DIN / EPDM			
PART NO.	SIZE	ID	OD
40MP-E20MDIN	DN20	23	33
40MP-E25MDIN	DN25	30	40
40MP-E32MDIN	DN32	36	46
40MP-E40MDIN	DN40	42	52
40MP-E50MDIN	DN50	54	64
40MP-E65MDIN	DN65	71	81
40MP-E80MDIN	DN80	85	95
40MP-E100MDIN	DN100	104	114

G



GASKET FOR DIN / VITON®			
PART NO.	SIZE	ID	OD
40MP-V20MDIN	DN20	23	33
40MP-V25MDIN	DN25	30	40
40MP-V32MDIN	DN32	36	46
40MP-V40MDIN	DN40	42	52
40MP-V50MDIN	DN50	54	64
40MP-V65MDIN	DN65	71	81
40MP-V80MDIN	DN80	85	95
40MP-V100MDIN	DN100	104	114



GASKET FOR DIN / BUNA			
PART NO.	SIZE	ID	OD
40MP-U20MDIN	DN20	23	33
40MP-U25MDIN	DN25	30	40
40MP-U32MDIN	DN32	36	46
40MP-U40MDIN	DN40	42	52
40MP-U50MDIN	DN50	54	64
40MP-U65MDIN	DN65	71	81
40MP-U80MDIN	DN80	85	95
40MP-U100MDIN	DN100	104	114

PLEASE CALL FOR ALL YOUR OTHER DIN REQUIREMENTS. MANY OTHER PARTS AVAILABLE.

IDF BS:4825 Part 4 Couplings and Gaskets

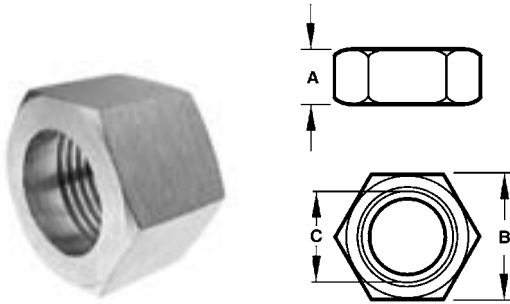

IDF HEX NUT				
PART NO.	SIZE	A (mm)	B (mm)	C (mm)
13H-G100IDF	1"	30	46	34.34 X 8T ACME
13H-G150IDF	1 1/2"	30	60	47.86 X 8T ACME
13H-G200IDF	2"	30	75	61.37 X 8T ACME
13H-G250IDF	2 1/2"	30	90	74.88 X 8T ACME
13H-G300IDF	3"	30	105	88.40 X 8T ACME
13H-G400IDF	4"	34.9	133	122.05 X 6T ACME



IDF BLANK CAP	
PART NO.	SIZE
16AMP-R100IDF	1"
16AMP-R150IDF	1 1/2"
16AMP-R200IDF	2"
16AMP-R250IDF	2 1/2"
16AMP-R300IDF	3"
16AMP-R400IDF	4"

Please note: Blanks can only be used with a matching nut.



IDF BLANK NUT WITH CHAIN	
PART NO.	SIZE
13HBN-G100IDF	1"
13HBN-G150IDF	1 1/2"
13HBN-G200IDF	2"
13HBN-G250IDF	2 1/2"
13HBN-G300IDF	3"
13HBN-G400IDF	4"



IDF SPANNER	
PART NO.	SIZE
IDF-1SP	1"
IDF-2SP	1 1/2"
IDF-2SP	2"
IDF2.5SP	2 1/2"
IDF-3SP	3"
IDF-4SP	4"

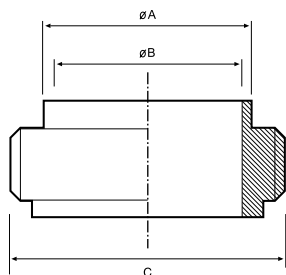

IDF WELD MALE				
PART NO.	SIZE	A (mm)	B (mm)	C (mm)
15A-R100IDF	1"	25.4	22.1	37.13 x 8T
15A-R150IDF	1 1/2"	38.1	34.8	50.65 x 8T
15A-R200IDF	2"	50.8	47.5	64.16 x 8T
15A-R250IDF	2 1/2"	63.5	60.2	77.67 x 8T
15A-R300IDF	3"	76.2	72.9	91.19 x 8T
15A-R400IDF	4"	101.6	97.6	125.9 x 6T

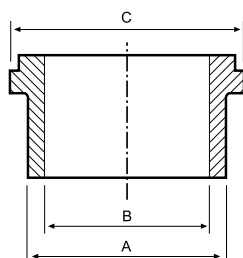

IDF WELD LINER				
PART NO.	SIZE	A (mm)	B (mm)	C (mm)
14A-R100IDF	1"	25.4	22.1	33.80
14A-R150IDF	1 1/2"	38.1	34.8	47.00
14A-R200IDF	2"	50.8	47.5	60.50
14A-R250IDF	2 1/2"	63.5	60.2	74.00
14A-R300IDF	3"	76.2	72.9	87.50
14A-R400IDF	4"	101.6	97.6	120.60

G

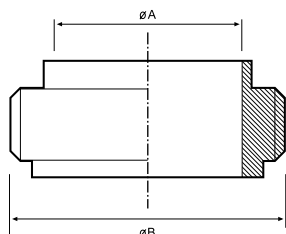

IDF EXPANDING MALE			
PART NO.	SIZE	A (mm)	B (mm)
15R-R100IDF	1"	22.20	37.13 x 8T
15R-R150IDF	1 1/2"	34.90	50.65 x 8T
15R-R200IDF	2"	47.60	64.16 x 8T
15R-R250IDF	2 1/2"	60.30	77.67 x 8T
15R-R300IDF	3"	73.00	91.19 x 8T
15R-R350IDF	4"	97.60	125.9 x 6T

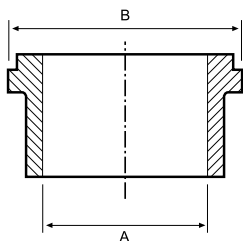

IDF EXPANDING LINER			
PART NO.	SIZE	A (mm)	B (mm)
14R-R100IDF	1"	22.30	33.80
14R-R150IDF	1 1/2"	34.90	47.00
14R-R200IDF	2"	47.60	60.50
14R-R250IDF	2 1/2"	60.30	74.00
14R-R300IDF	3"	73.00	87.50
14R-R400IDF	4"	97.60	120.60



HOLEDALL® IDF EXTERNAL CRIMP STEM	
PART NO.	SIZE
FEMALE	
HA0628	1"
HA0629	1 1/2"
HA0630	2"
HA0631	2 1/2"
HA0632	3"
HA0633	4"
MALE	
HA0634	1"
HA0635	1"
HA0636	2"
HA0637	2 1/2"
HA0638	3"
HA0639	4"

Please note: All stems are manufactured to suit inch bore hoses (not metric hose bores).

HOLEDALL® IDF EXTERNAL CRIMP FERRULES



PART NO.	SIZE	HOSE OD RANGE (mm)	
		From	To
F16G-1453	1"	35.7	36.5
F16G-1500	1"	36.9	37.7
F16G-1547	1"	38.1	38.9
F16G-1594	1"	39.3	40.1
F16G-1641	1"	40.5	41.3
F24G-1969	1 1/2"	48.4	49.6
F24G-2031	1 1/2"	50.0	51.2
F24G-2094	1 1/2"	51.6	52.8
F24G-2156	1 1/2"	53.2	54.4
F32G-2531	2"	62.7	63.9
F32G-2594	2"	64.3	65.5
F32G-2656	2"	65.9	67.1
F32G-2719	2"	67.4	68.7
F40G-3070	2 1/2"	76.1	78.1
F40G-3150	2 1/2"	78.1	80.1
F40G-3268	2 1/2"	81.1	83.1
F48G-3525	3"	91.7	92.9
F48G-3688	3"	92.1	93.3
F48G-3750	3"	93.6	94.9
F48G-3813	3"	95.2	96.5
F48G-3875	3"	96.8	98.0
F48G-3938	3"	98.4	99.6
F64G-3625	4"	117.5	118.7
F64G-4750	4"	119.0	120.3
F64G-4813	4"	120.6	121.9
F64G-4875	4"	122.2	123.5
F64G-4938	4"	123.8	125.0



SEAL TYPE IDF O-RING EPDM			
PART NO.	SIZE	ID	OD
40MP-E100IDF	1"	23.20	32.50
40MP-E150IDF	1 1/2"	35.90	46.00
40MP-E200IDF	2"	48.60	59.50
40MP-E250IDF	2 1/2"	61.30	73.20
40MP-E300IDF	3"	74.00	86.50
40MP-E400IDF	4"	98.60	119.00



SEAL TYPE IDF O-RING VITON®			
PART NO.	SIZE	ID	OD
40MP-SFY100IDF	1"	23.20	32.50
40MP-SFY150IDF	1 1/2"	35.90	46.00
40MP-SFY200IDF	2"	48.60	59.50
40MP-SFY250IDF	2 1/2"	61.30	73.20
40MP-SFY300IDF	3"	74.00	86.50
40MP-SFY400IDF	4"	98.60	119.00

G



SEAL TYPE IDF O-RING BUNA (NITRILE)			
PART NO.	SIZE	ID	OD
40MP-U100IDF	1"	23.20	32.50
40MP-U150IDF	1 1/2"	35.90	46.00
40MP-U200IDF	2"	48.60	59.50
40MP-U250IDF	2 1/2"	61.30	73.20
40MP-U300IDF	3"	74.00	86.50
40MP-U400IDF	4"	98.60	119.00



GASKET FOR IDF / SILICONE			
PART NO.	SIZE	ID	OD
40MP-X100IDF	1"	23.20	32.50
40MP-X150IDF	1 1/2"	35.90	46.00
40MP-X200IDF	2"	48.60	59.50
40MP-X250IDF	2 1/2"	61.30	73.20
40MP-X300IDF	3"	74.00	86.50
40MP-X400IDF	4"	98.60	119.00

PLEASE CALL FOR ALL YOUR OTHER IDF REQUIREMENTS. MANY OTHER PARTS AVAILABLE.

SMS Unions, Tools & Gaskets

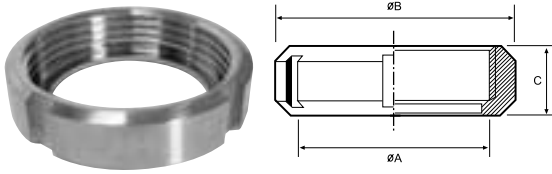

SMS NUT 6 SLOTS				
PART NO.	SIZE	A (mm)	B (mm)	C (mm)
13R-G100SMS	1"	40 x 1/6	51.00	19.00
13R-G150SMS	1 1/2"	60 x 1/6	74.00	23.00
13R-G200SMS	2"	70 x 1/6	84.00	24.00
13R-G250SMS	2 1/2"	85 x 1/6	100.00	28.00
13R-G300SMS	3"	98 x 1/6	114.00	30.00
13R-G400SMS	4"	125 x 1/4	138.00	31.00



SMS BLANK	
PART NO.	SIZE
16AMP-R100SMS	1"
16AMP-R150SMS	1 1/2"
16AMP-R200SMS	2"
16AMP-R250SMS	2 1/2"
16AMP-R300SMS	3"
16AMP-R400SMS	4"

Please note: To be used with a matching nut.



SMS BLANK NUT 6 SLOTS WITH CHAIN	
PART NO.	SIZE
13RBN-G100SMS	1"
13RBN-G150SMS	1 1/2"
13RBN-G200SMS	2"
13RBN-G250SMS	2 1/2"
13RBN-G300SMS	3"
13RBN-G400SMS	4"

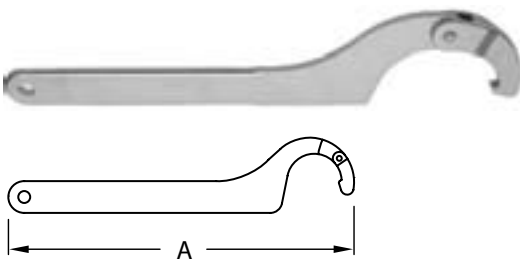

SMS SPANNER		
PART NO.	SIZE	A
DIN-SMS-60/90SP	1" - 1 1/2"	11.00
DIN-SMS-90/155SP	2" - 4"	13.00

For use on DIN or SMS Rounded Nuts.

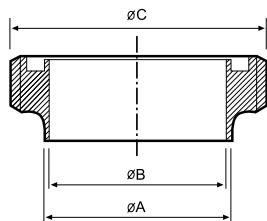

SMS WELD MALE				
PART NO.	SIZE	A (mm)	B (mm)	C (mm)
15A-R100SMS	1"	25.4	22.1	40x1/6
15A-R150SMS	1 1/2"	38.1	34.8	60x1/6
15A-R200SMS	2"	50.8	47.5	70x1/6
15A-R250SMS	2 1/2"	63.5	60.2	85x1/6
15A-R300SMS	3"	76.2	72.9	98x1/6
15A-R400SMS	4"	101.6	97.6	125x1/4

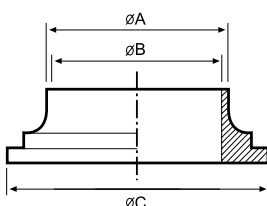

SMS WELD LINER				
PART NO.	SIZE	A (mm)	B (mm)	C (mm)
14A-R100SMS	1"	25.4	22.1	35.50
14A-R150SMS	1 1/2"	38.1	34.8	55.00
14A-R200SMS	2"	50.8	47.5	65.00
14A-R250SMS	2 1/2"	63.5	60.2	80.00
14A-R300SMS	3"	76.2	72.9	93.00
14A-R400SMS	4"	101.6	97.6	118.00

G

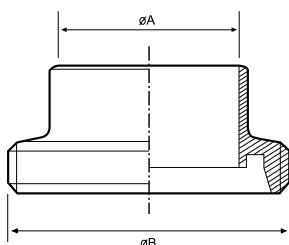

SMS EXPANDING MALE			
PART NO.	SIZE	A (mm)	B (mm)
15R-R100SMS	1"	22.20	40x1/6
15R-R150SMS	1 1/2"	34.90	60x1/6
15R-R200SMS	2"	47.60	70x1/6
15R-R250SMS	2 1/2"	60.30	85x1/6
15R-R300SMS	3"	73.00	98x1/6
15R-R400SMS	4"	97.60	125x1/4

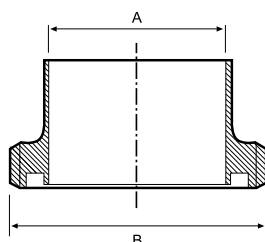

SMS EXPANDING LINER			
PART NO.	SIZE	A (mm)	B (mm)
14R-R100SMS	1"	22.20	35.50
14R-R150SMS	1 1/2"	34.90	55.00
14R-R200SMS	2"	47.60	65.00
14R-R250SMS	2 1/2"	60.30	80.00
14R-R300SMS	3"	73.00	93.00
14R-R400SMS	4"	97.60	118.00



HOLEDALL® SMS EXTERNAL CRIMP STEM	
PART NO.	SIZE
FEMALE	
HA0616	1"
HA0617	1 1/2"
HA0618	2"
HA0619	2 1/2"
HA0620	3"
HA0621	4"
MALE	
HA0622	1"
HA0623	1 1/2"
HA0624	2"
HA0625	2 1/2"
HA0626	3"
HA0627	4"

Please note: All stems are manufactured to suit inch bore hoses (not metric hose bores).



HOLEDALL® SMS EXTERNAL CRIMP FERRULES			
PART NO.	SIZE	HOSE OD RANGE (mm)	
		From	To
F16G-1453	1"	35.7	36.5
F16G-1500	1"	36.9	37.7
F16G-1547	1"	38.1	38.9
F16G-1594	1"	39.3	40.1
F16G-1641	1"	40.5	41.3
F24G-1969	1 1/2"	48.4	49.6
F24G-2031	1 1/2"	50.0	51.2
F24G-2094	1 1/2"	51.6	52.8
F24G-2156	1 1/2"	53.2	54.4
F32G-2531	2"	62.7	63.9
F32G-2594	2"	64.3	65.5
F32G-2656	2"	65.9	67.1
F32G-2719	2"	67.4	68.7
F40G-3070	2 1/2"	76.1	78.1
F40G-3150	2 1/2"	78.1	80.1
F40G-3268	2 1/2"	81.1	83.1
F48G-3525	3"	91.7	92.9
F48G-3688	3"	92.1	93.3
F48G-3750	3"	93.6	94.9
F48G-3813	3"	95.2	96.5
F48G-3875	3"	96.8	98.0
F48G-3938	3"	98.4	99.6
F64G-3625	4"	117.5	118.7
F64G-4750	4"	119.0	120.3
F64G-4813	4"	120.6	121.9
F64G-4875	4"	122.2	123.5
F64G-4938	4"	123.8	125.0

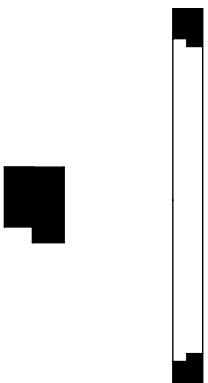

SMS SEAL RING L TYPE SILICONE

PART NO.	SIZE	ID	OD
40MP-XW100SMS	1"	22.80	31.80
40MP-XW150SMS	1 1/2"	35.80	47.80
40MP-XW200SMS	2"	48.80	60.80
40MP-XW250SMS	2 1/2"	61.00	73.30
40MP-XW300SMS	3"	73.40	85.80
40MP-XW400SMS	4"	98.20	115.70

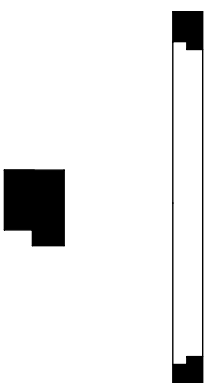

SMS SEAL RING L TYPE EPDM

PART NO.	SIZE	ID	OD
40MP-E100SMS	1"	22.80	31.80
40MP-E150SMS	1 1/2"	35.80	47.80
40MP-E200SMS	2"	48.80	60.80
40MP-E250SMS	2 1/2"	61.00	73.30
40MP-E300SMS	3"	73.40	85.80
40MP-E400SMS	4"	98.20	115.70

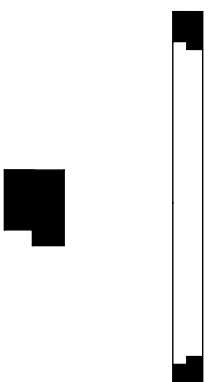

SEAL TYPE SMS O-RING VITON®

PART NO.	SIZE	ID	OD
40MP-SFY100SMS	1"	22.80	31.80
40MP-SFY150SMS	1 1/2"	35.80	47.80
40MP-SFY200SMS	2"	48.80	60.80
40MP-SFY250SMS	2 1/2"	61.00	73.30
40MP-SFY300SMS	3"	73.40	85.80
40MP-SFY400SMS	4"	98.20	115.70

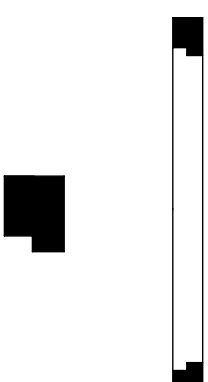

SEAL TYPE SMS O-RING BUNA (NITRILE)

PART NO.	SIZE	ID	OD
40MP-U100SMS	1"	22.80	31.80
40MP-U150SMS	1 1/2"	35.80	47.80
40MP-U200SMS	2"	48.80	60.80
40MP-U250SMS	2 1/2"	61.00	73.30
40MP-U300SMS	3"	73.40	85.80
40MP-U400SMS	4"	98.20	115.70

PLEASE CALL FOR ALL YOUR OTHER SMS REQUIREMENTS. MANY OTHER PARTS AVAILABLE.

Clamp Type BS:4825 Part 3 Couplings and Gaskets

Service ratings are based on hydrostatic tests using standard-molded Buna-N material gaskets, with proper installation of ferrules, assembly of joints and absence of shock pressure. Contact Dixon Hygienic for service of other type and material gaskets, and for ratings at higher temperatures. All ratings shown are dependent upon related components within the systems and proper installation. **For temperatures above 250°F/121°C, we recommend using only 13MHP clamps.** This information is only valid if Bradford™ clamps, ferrules and gaskets are used.

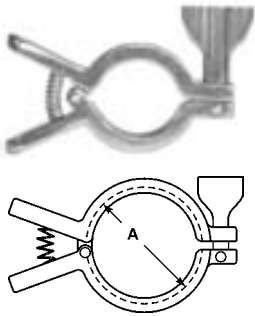

SINGLE PIN SQUEEZE CLAMPS – 13MHHM-Q

PART NO.	TUBE O.D.	SERVICE PRESSURE RATING (PSI/BAR)	SERVICE PRESSURE RATING (PSI/BAR)	DIMENSION A
		@ 70°F/21°C	@ 250°F/121°C	
13MHHM-Q75	1/2" - 3/4"	1500/103	1200/82	26.97
13MHHM-Q100-150	1" - 1 1/2"	500/34	300/20	53.90
13MHHM-Q200	2"	450/31	250/17	67.41
13MHHM-Q250	2 1/2"	400/27	200/13	80.91
13MHHM-Q300	3"	350/24	175/12	94.41
13MHHM-Q400	4"	300/20	150/10	122.43

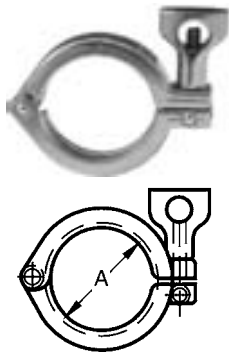

SINGLE PIN HEAVY DUTY CLAMP – 13MHHM

PART NO.	TUBE O.D.	SERVICE PRESSURE RATING (PSI/BAR)	SERVICE PRESSURE RATING (PSI/BAR)	DIMENSION A
		@ 70°F/21°C	@ 250°F/121°C	
13MHHM50-75	1/2" - 3/4"	1500/103	1200/82	26.97
13MHHM100-150	1" - 1 1/2"	500/34	300/20	53.90
13MHHM200	2"	450/31	250/17	67.41
13MHHM250	2 1/2"	400/27	200/13	80.91
13MHHM300	3"	350/24	175/12	94.41
13MHHM400	4"	300/20	150/10	122.43
13MHHM600	6"	150/10	75/5	170.05
13MHHM800	8"	100/6	50/3.45	220.85

* Also available in 316 Stainless Steel. See page 177

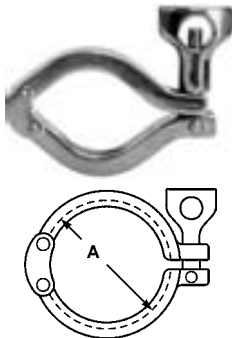

DOUBLE PIN HEAVY DUTY CLAMP – 13MHHM – DP

PART NO.	TUBE O.D.	SERVICE PRESSURE RATING (PSI/BAR)	SERVICE PRESSURE RATING (PSI/BAR)	DIMENSION A
		@ 70°F/21°C	@ 250°F/121°C	
13MHHM-DP100-150	1" - 1 1/2"	500/34	300/20	26.97
13MHHM-DP200	2"	450/31	250/17	53.90
13MHHM-DP250	2 1/2"	400/27	200/13	67.41
13MHHM-DP300	3"	350/24	175/12	80.91
13MHHM-DP400	4"	300/20	150/10	94.41
13MHHM-DP1000	10"	100/6	50/3.45	272.80

* Also available in 316 Stainless Steel. See page 177

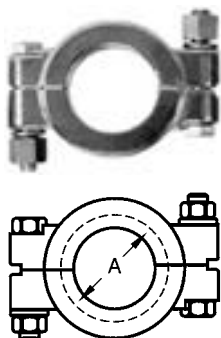

HYGIENIC CLAMPS / BOLTED CLAMP – 13MHP

PART NO.	TUBE O.D.	SERVICE PRESSURE RATING (PSI/BAR)	SERVICE PRESSURE RATING (PSI/BAR)	DIMENSION A
		@ 70°F/21°C	@ 250°F/121°C	
13MHP75	1/2" - 3/4"	1500/103	1200/82	26.97
13MHP100-150	1" - 1 1/2"	1500/103	1200/82	53.90
13MHP200	2"	1000/69	800/55	67.41
13MHP250	2 1/2"	1000/69	800/55	80.91
13MHP300	3"	1000/69	800/55	94.41
13MHP400	4"	800/55	600/40	122.43
13MHP600	6"	300/20	200/13	170.05
13MHP800	8"	250/17	150/10	220.85
13MHP1000	10"	200/13	125/8.5	272.80
13MHP1200	12"	150/10	100/6	323.60

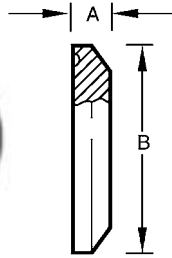

SOLID FERRULE BLANK DISC END CAPS – 16AMP

PART NO.	TUBE O.D.	DIMENSIONS	
		A	B
16AMP-R50-75	1/2" - 3/4"	4.75	25.20
16AMP-R100-150	1" - 1 1/2"	6.35	50.40
16AMP-R200	2"	6.35	63.91
16AMP-R250	2 1/2"	6.35	77.39
16AMP-R300	3"	6.35	90.91
16AMP-R400	4"	7.92	118.92
16AMP-R600	6"	11.10	166.88
16AMP-R800	8"	11.10	217.68
16AMP-R1000	10"	11.10	266.48
16AMP-R1200	12"	11.10	319.28

G

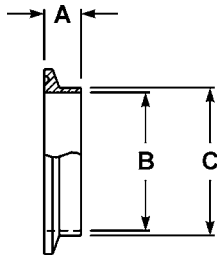

SHORT WELDING FERRULE

PART NO.	TUBE O.D.	DIMENSIONS		
		A	B	C
14WMP-R50	1/2"	12.70	9.40	12.70
14WMP-R75	3/4"	12.70	15.75	19.05
14WMP-R100	1"	12.70	22.10	25.40
14WMP-R150	1 1/2"	12.70	34.80	38.00
14WMP-R200	2"	12.70	47.50	50.80
14WMP-R250	2 1/2"	12.70	60.20	63.50
14WMP-R300	3"	12.70	72.90	76.20
14WMP-R400	4"	15.86	97.60	101.60
14WMP-R600	6"	22.23	146.86	152.40
14WMP-R800	8"	22.23	197.66	203.20
14WMP-R1000	10"	22.23	248.46	254.00
14WMP-R1200	12"	22.23	298.70	304.80

BUTT WELD FERRULES

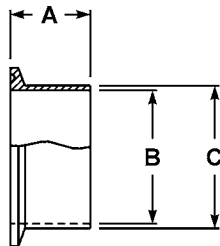

PART NO.	TUBE O.D.	DIMENSIONS		
		A	B	C
L14AM7-R50	1/2"	28.56	9.40	12.70
L14AM7-R75	3/4"	28.56	15.75	19.05
L14AM7-R100	1"	28.56	22.10	25.40
L14AM7-R150	1 1/2"	28.56	34.80	38.00
L14AM7-R200	2"	28.56	47.50	50.80
L14AM7-R250	2 1/2"	28.56	60.20	63.50
L14AM7-R300	3"	28.56	72.90	76.20
L14AM7-R400	4"	28.56	97.60	101.60
L14AM7-R600	6"	38.10	146.86	152.40
L14AM7-R800	8"	38.10	197.66	203.20
L14AM7-R1000	10"	44.45	248.46	254.00
L14AM7-R1200	12"	44.45	298.70	304.80

Please note: Metric sizes to DIN32676 available on request.

CLAMP HOSE TAIL

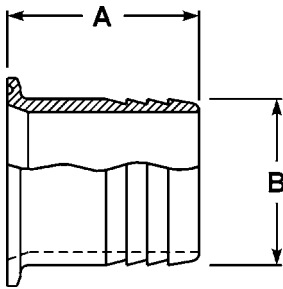

PART NO.	TUBE O.D.	DIMENSIONS	
		A	B
14MPHR-R50125	1/2" x 1/8"	31.75	3.18
14MPHR-R5025	1/2" x 1/4"	38.10	6.35
14MPHR-R50375	1/2" x 3/8"	38.10	9.53
14MPHR-R50	1/2" x 1/2"	38.10	12.07
14MPHR-R5075	1/2" x 3/4"	38.10	19.05
14MPHR-R75125	3/4" x 1/8"	38.10	3.18
14MPHR-R7525	3/4" x 1/4"	38.10	6.35
14MPHR-R75375	3/4" x 3/8"	38.10	9.53
14MPHR-R7550	3/4" x 1/2"	38.10	12.07
14MPHR-R75	3/4" x 3/4"	38.10	19.05
14MPHR-R100	1" x 1"	42.88	25.4
14MPHR-R100375	1" x 3/8"	38.10	9.53
14MPHR-R10050	1" x 1/2"	38.10	12.7
14MPHR-R10075	1" x 3/4"	42.88	19.05
14MPHR-R15025	1 1/2" x 1/4"	38.10	6.35
14MPHR-R150375	1 1/2" x 3/8"	38.10	9.53
14MPHR-R15050	1 1/2" x 1/2"	38.10	12.7
14MPHR-R150625	1 1/2" x 5/8"	38.10	15.88
14MPHR-R15075	1 1/2" x 3/4"	38.10	19.05
14MPHR-R150100	1 1/2" x 1"	42.88	25.4
14MPHR-R150125	1 1/2" x 1 1/4"	42.88	31.75
14MPHR-R150	1 1/2" x 1 1/2"	42.88	38.1
14MPHR-R200	2" x 2"	58.72	50.8
14MPHR-R200150	2" x 1 1/2"	58.72	38.1
14MPHR-R250	2 1/2" x 2 1/2"	58.72	63.5
14MPHR-R300	3" x 3"	78.59	76.2
14MPHR-R400	4" x 4"	86.51	101.6
14MPHR-R600	6" x 6"	86.51	152.4
14MPHR-R800	8" x 8"	86.51	203.2

Please note: All stems are manufactured to suit inch bore hoses (not metric hose bores).

G



HOLEDALL® CLAMP TYPE EXTERNAL CRIMP STEM

PART NO.	SIZE
CSSR100	1"
CSSR150	1 1/2"
CSSR200	2"
CSSR250	2 1/2"
CSSR300	3"
CSSR400	4"

Please note: All stems are manufactured to suit inch bore hoses (not metric hose bores).

1/2" & 3/4" available on request.

HOLEDALL® CLAMP TYPE EXTERNAL CRIMP FERRULES



PART NO.	SIZE	HOSE OD RANGE (mm)	
		From	To
F16G-1453	1"	35.7	36.5
F16G-1500	1"	36.9	37.7
F16G-1547	1"	38.1	38.9
F16G-1594	1"	39.3	40.1
F16G-1641	1"	40.5	41.3
F24G-1969	1 1/2"	48.4	49.6
F24G-2031	1 1/2"	50.0	51.2
F24G-2094	1 1/2"	51.6	52.8
F24G-2156	1 1/2"	53.2	54.4
F32G-2531	2"	62.7	63.9
F32G-2594	2"	64.3	65.5
F32G-2656	2"	65.9	67.1
F32G-2719	2"	67.4	68.7
F40G-3070	2 1/2"	76.1	78.1
F48G-3525	3"	91.7	92.9
F48G-3688	3"	92.1	93.3
F48G-3750	3"	93.6	94.9
F48G-3813	3"	95.2	96.5
F48G-3875	3"	96.8	98.0
F48G-3938	3"	98.4	99.6
F64G-3625	4"	117.5	118.7
F64G-4750	4"	119.0	120.3

G

BUNA-N BLACK -40°C TO 107°C

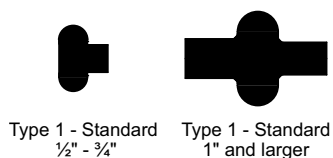

PART NO.	SIZE
42MP-U50	1/2"
42MP-U75	3/4"
40MP-U100	1"
40MP-U150	1 1/2"
40MP-U200	2"
40MP-U250	2 1/2"
40MP-U300	3"
40MP-U400	4"
40MP-U600	6"

VITON® BLACK -29°C TO 204°C

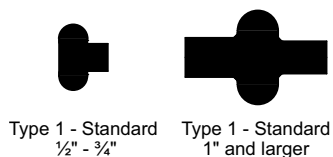

PART NO.	SIZE
42MP-SFY50	1/2"
42MP-SFY75	3/4"
40MP-SFY100	1"
40MP-SFY150	1 1/2"
40MP-SFY200	2"
40MP-SFY250	2 1/2"
40MP-SFY300	3"
40MP-SFY400	4"

BUNA-N WHITE -40°C TO 107°C



Type 1 - Standard
1/2" - 3/4"

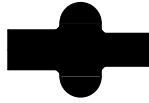

Type 1 - Standard
1" and larger

PART NO.	SIZE
42MP-UW50	1/2"
42MP-UW75	3/4"
40MP-UW100	1"
40MP-UW150	1 1/2"
40MP-UW200	2"
40MP-UW250	2 1/2"
40MP-UW300	3"
40MP-UW400	4"

PTFE (SOLID) WHITE -73°C TO 204°C



Type 1 - Standard
1/2" - 3/4"

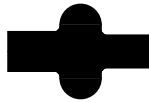

Type 1 - Standard
1" and larger

PART NO.	SIZE
42MP-G50	1/2"
42MP-G75	3/4"
40MP-G100	1"
40MP-G150	1 1/2"
40MP-G200	2"
40MP-G250	2 1/2"
40MP-G300	3"
40MP-G400	4"

G

EPDM BLACK -60°C TO 135°C



Type 1 - Standard
1/2" - 3/4"

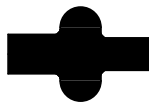

Type 1 - Standard
1" and larger

PART NO.	SIZE
42MP-E50	1/2"
42MP-E75	3/4"
40MP-E100	1"
40MP-E150	1 1/2"
40MP-E200	2"
40MP-E250	2 1/2"
40MP-E300	3"
40MP-E400	4"

Also Available Type 2 as flanged gasket

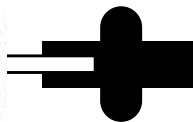

Type 3 Mesh
1" - 4"

- Colour code: one white dot, one yellow dot
- 10 mesh standard. Other mesh sizes available.
- Peroxide cured
- Meets 21CFR 177.2600
- Pharmaceutical class VI approved
- Please contact us for compatibility information
- Additional mesh sizes available, please contact us for details

EPDM - MESH SCREEN, 316

PART NO.	SIZE
40MPS-E100	1"
40MPS-E150	1 1/2"
40MPS-E200	2"
40MPS-E250	2 1/2"
40MPS-E300	3"
40MPS-E400	4"

Please note: Mesh Screen Gaskets are also available in Silicone, Buna and Viton®. 10 Mesh standard.

Clamp Flanged Gaskets

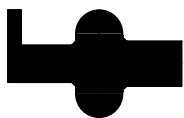

Type 2 - Flanged
1" and larger

- Colour code: red dot
- Meets 21CFR 177.2600
- Refer to the technical section for compatibility information
- Not recommended for use with bolted clamps

BUNA-N - BLACK, FLANGED	
PART NO.	SIZE
40MPF-U100	1"
40MPF-U150	1½"
40MPF-U200	2"
40MPF-U250	2½"
40MPF-U300	3"
40MPF-U400	4"
40MPF-U600	6"
40MPF-U800	8"
40MPF-U1000	10"
40MPF-U1200	12"

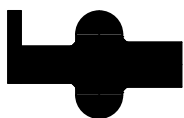

Type 2 - Flanged
1" and larger

- Colour code: red dot
- Meets 21CFR 177.2600
- Refer to the technical section for compatibility information
- Not recommended for use with bolted clamps

BUNA-N - WHITE, FLANGED	
PART NO.	SIZE
40MPF-UW100	1"
40MPF-UW150	1½"
40MPF-UW200	2"
40MPF-UW250	2½"
40MPF-UW300	3"
40MPF-UW400	4"
40MPF-UW600	6"
40MPF-UW800	8"

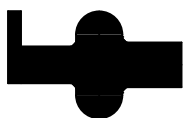

Type 2 - Flanged
1" and larger

- Colour code: three green dots
- Peroxide cured
- Meets 21CFR 177.2600
- Passed U.S.P. Class VI Cytotoxicity testing
- Refer to the technical section for compatibility information
- Not recommended for use with bolted clamps

EPDM - FLANGED	
PART NO.	SIZE
40MPF-E100	1"
40MPF-E150	1½"
40MPF-E200	2"
40MPF-E250	2½"
40MPF-E300	3"
40MPF-E400	4"
40MPF-E600	6"
40MPF-E800	8"
40MPF-E1000	10"
40MPF-E1200	12"

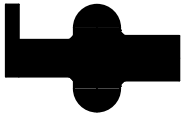

Type 2 - Flanged
1" and larger

- Colour code: one white dot, one yellow dot
- Meets 21CFR 177.2600
- Passed U.S.P. Class VI Cytotoxicity testing
- Refer to the technical section for compatibility information
- Not recommended for use with bolted clamps

FKM (VITON®) - FLANGED

PART NO.	SIZE
40MPF-SFY100	1"
40MPF-SFY150	1½"
40MPF-SFY200	2"
40MPF-SFY250	2½"
40MPF-SFY300	3"
40MPF-SFY400	4"
40MPF-SFY600	6"
40MPF-SFY800	8"
40MPF-SFY1000	10"
40MPF-SFY1200	12"

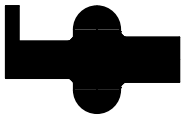

Type 2 - Flanged
1" and larger

- Colour code: pink dot
- Peroxide cured
- Meets 21CFR 177.2600
- Passed U.S.P. Class VI Cytotoxicity testing
- Refer to the technical section for compatibility information
- Not recommended for use with bolted clamps

SILICONE - WHITE, FLANGED

PART NO.	SIZE
40MPF-XW100	1"
40MPF-XW150	1½"
40MPF-XW200	2"
40MPF-XW250	2½"
40MPF-XW300	3"
40MPF-XW400	4"
40MPF-XW600	6"
40MPF-XW800	8"
40MPF-XW1000	10"
40MPF-XW1200	12"

G

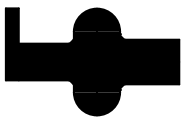

Type 2 - Flanged
1" and larger

- Colour code: no dot
- Platinum cured
- Meets 21CFR 177.2600
- Passed U.S.P. Class VI Cytotoxicity testing
- Refer to the technical section for compatibility information
- Not recommended for use with bolted clamps

SILICONE - CLEAR, FLANGED

PART NO.	SIZE
40MPF-XC100	1"
40MPF-XC150	1½"
40MPF-XC200	2"
40MPF-XC250	2½"
40MPF-XC300	3"
40MPF-XC400	4"
40MPF-XC600	6"
40MPF-XC800	8"

Clamp Envelope Gaskets

CAUTION

PTFE is a material subject to plastic flow. When cycled through heat and then cooled down in process lines, PTFE gaskets will not return to the original configuration and it will continue to compress as the cycling continues. This plastic flow will allow leakage if clamp torques are not maintained.

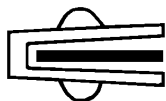

- Colour code: usually not marked
- Peroxide cured
- Meets 21CFR 177.1550
- Refer to the technical section for compatibility information

PTFE ENVELOPE WITH EPDM FILLER

PART NO.	SIZE
42MP-GRE50	1/2"
42MP-GRE75	3/4"
40MP-GRE100	1"
40MP-GRE150	1 1/2"
40MP-GRE200	2"
40MP-GRE250	2 1/2"
40MP-GRE300	3"
40MP-GRE400	4"



- Colour code: usually not marked
- Meets 21CFR 177.1550
- Refer to the technical section for compatibility information

PTFE ENVELOPE WITH FKM (VITON®) FILLER

PART NO.	SIZE
42MP-GR50	1/2"
42MP-GR75	3/4"
40MP-GR100	1"
40MP-GR150	1 1/2"
40MP-GR200	2"
40MP-GR250	2 1/2"
40MP-GR300	3"
40MP-GR400	4"
40MP-GR600	6"
40MP-GR800	8"

G

APC Clamp Gaskets



- Colour code: no dot
- Meets 21CFR 177.2600
- Refer to the technical section for compatibility information

BUNA APC - GREY

PART NO.	SIZE
101-H100	1"
101-H150	1 1/2"
101-H200	2"
101-H250	2 1/2"
101-H300	3"
101-H400	4"



- Colour code: no dot
- Meets 21CFR 177.2600
- Refer to the technical section for compatibility information

BUNA APC - GREY

PART NO.	SIZE
101-HX100	1"
101-HX150	1 1/2"
101-HX200	2"
101-HX250	2 1/2"
101-HX300	3"
101-HX400	4"

Clamp Gasket Sizing Guide *(continued overleaf)*

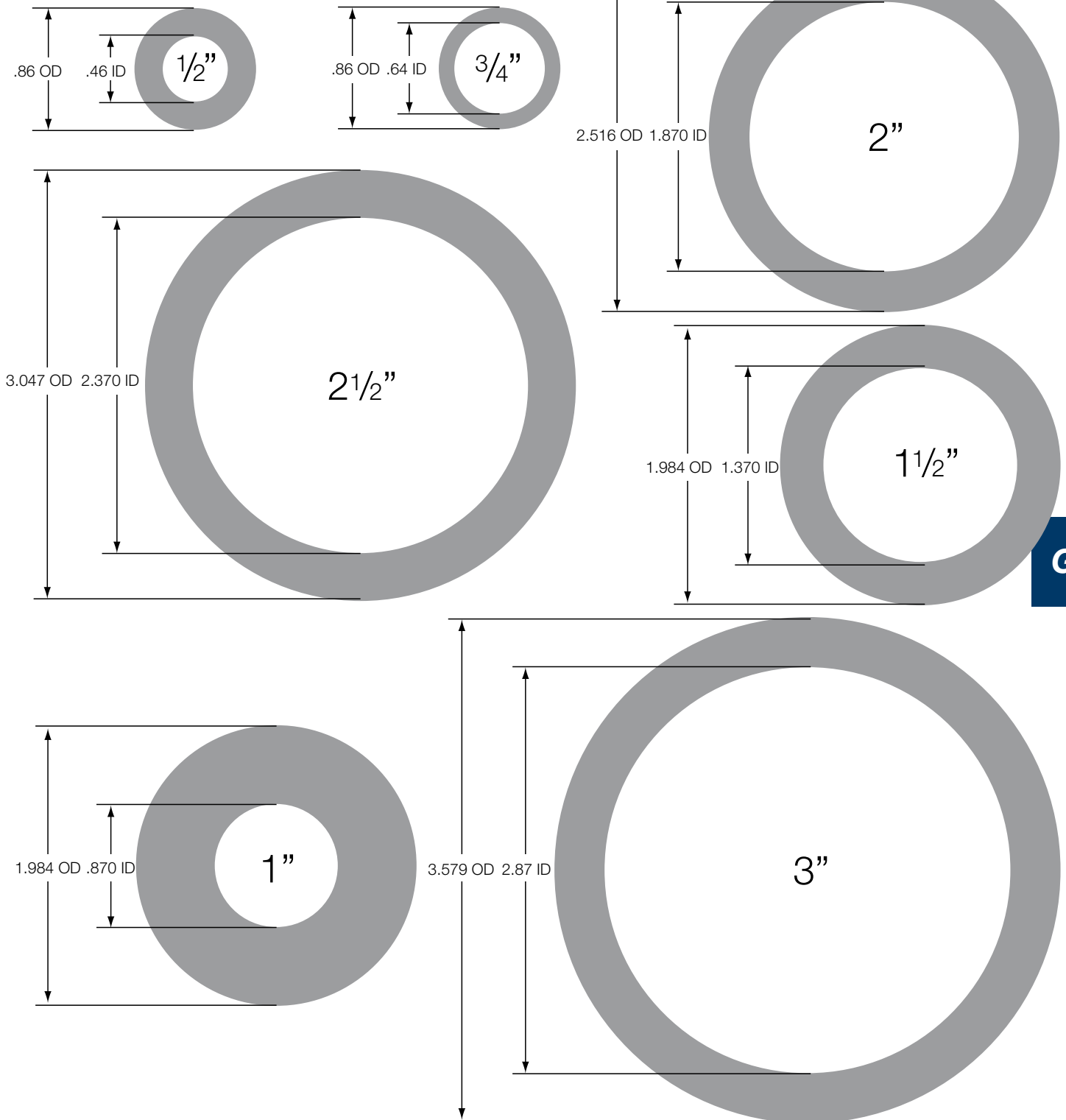

HYGIENIC SIZE	OD of CLAMP END	ID of FITTING	HYGIENIC SIZE	OD of CLAMP END	ID of FITTING
1/2"	0.992	0.370	3"	3.579	2.870
3/4"	0.992	0.620	4"	4.682	3.834
1"	1.984	0.870	6"	6.562	5.782
1 1/2"	1.984	1.370	8"	8.602	7.782
2"	2.516	1.870	10"	10.570	9.782
2 1/2"	3.047	2.370	12"	12.570	11.760

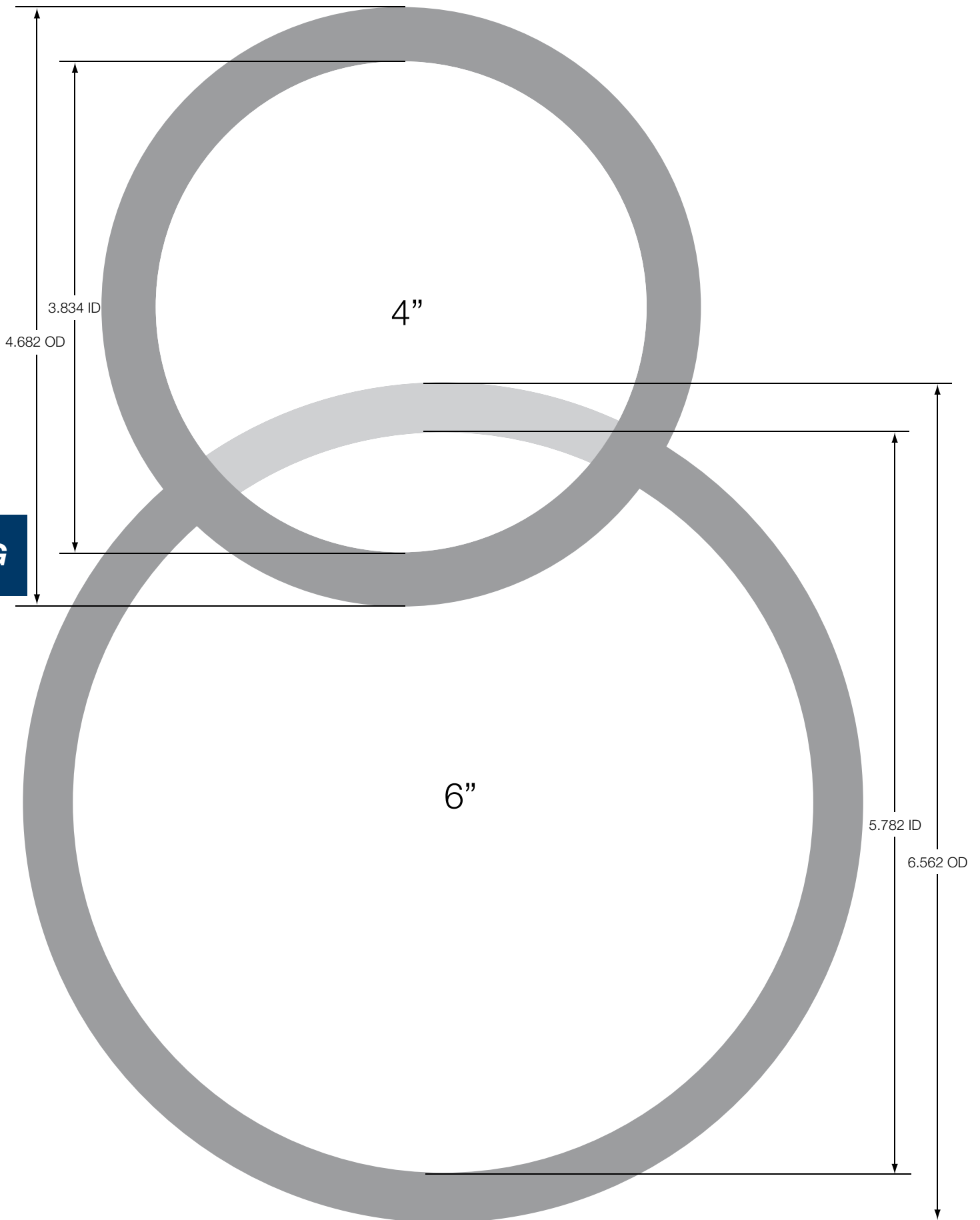

Polished Bends, Tee's & Reducers

High Quality Hygienic Weld Fittings - 3A Standard

All Dixon polished fittings have a surface finish equivalent to 150 grit or better OD, and 180 grit or better ID. A maximum of Ra 32 microinch (0.8 micron) is indicated.

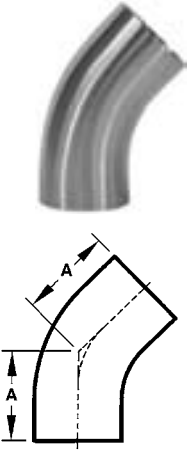

45° POLISHED ELBOWS - BUTT WELD B2KS

PART NO.	TUBE O.D.	DIMENSION A	NOMINAL WALL
B2KS-R50P	½"	2.250	0.065
B2KS-R75P	¾"	2.250	0.065
B2KS-R100P	1"	1.188	0.065
B2KS-R150P	1½"	1.625	0.065
B2KS-R200P	2"	2.312	0.065
B2KS-R250P	2½"	3.000	0.065
B2KS-R300P	3"	3.688	0.065
B2KS-R400P	4"	4.812	0.083

Polished 316L Stainless Steel.

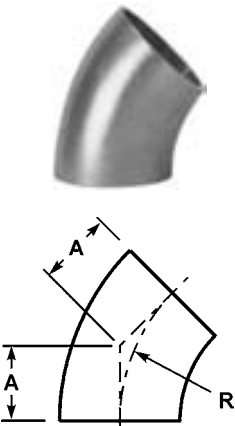

POLISHED ELBOWS LESS TANGENT – B2WK

PART NO.	TUBE O.D.	DIMENSION		NOMINAL WALL
		A	R	
B2WK-R50P	½"	.466	1.125	0.065
B2WK-R75P	¾"	.466	1.125	0.065
B2WK-R100P	1"	.625	1.500	0.065
B2WK-R150P	1½"	.937	2.250	0.065
B2WK-R200P	2"	1.250	3.000	0.065
B2WK-R250P	2½"	1.562	3.750	0.065
B2WK-R300P	3"	1.875	4.500	0.065
B2WK-R400P	4"	2.500	6.000	0.083
B2WK-R600P	6"	3.750	9.000	0.109
B2WK-R800P	8"	5.000	12.000	0.120
B2WK-R1000P	10"	6.250	15.000	0.109
B2WK-R1200P	12"	7.500	18.000	0.120

Polished 316L Stainless Steel.

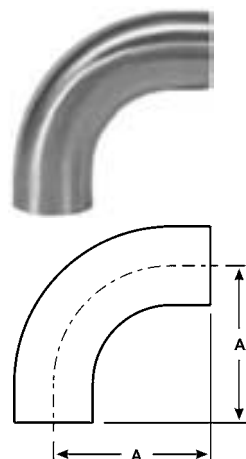

90° POLISHED ELBOWS – BUTT WELD ELBOWS WITH TANGENT – B2S

PART NO.	TUBE O.D.	DIMENSION A	NOMINAL WALL
B2S-R50P	½"	3.000	0.065
B2S-R75P	¾"	3.000	0.065
B2S-R100P	1"	2.062	0.065
B2S-R150P	1½"	2.937	0.065
B2S-R200P	2"	4.062	0.065
B2S-R250P	2½"	5.187	0.065
B2S-R300P	3"	6.312	0.065
B2S-R400P	4"	8.312	0.083

Polished 316L Stainless Steel.



HOLEDALL® WELD END EXTERNAL CRIMP STEM

PART NO.	SIZE
HA0833	1"
HA0835	1½"
HA0837	2"
HA0839	2½"
HA0841	3"
HA0843	4"

Please note: All stems are manufactured to suit inch bore hoses (not metric hose bores).
1/2" & 3/4" available on request.

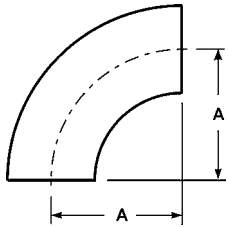

90° POLISHED ELBOWS – BUTT WELD ELBOWS LESS TANGENT – B2WCL

PART NO.	TUBE O.D.	DIMENSION A	NOMINAL WALL
B2WCL-R50P	½"	1.125	0.065
B2WCL-R75P	¾"	1.125	0.065
B2WCL-R100P	1"	1.500	0.065
B2WCL-R150P	1½"	2.250	0.065
B2WCL-R200P	1½"	3.000	0.065
B2WCL-R250P	2½"	3.750	0.065
B2WCL-R300P	3"	4.500	0.065
B2WCL-R400P	4"	6.000	0.083
B2WCL-R600P	6"	9.000	0.109
B2WCL-R800P	8"	12.000	0.120
B2WCL-R1000P	10"	15.000	0.109

Polished 316L Stainless Steel.

G

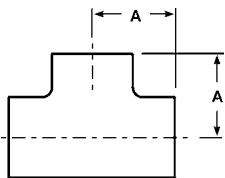

POLISHED TEES – BUTT WELD / SHORT TEE-B7WWW

PART NO.	TUBE O.D.	DIMENSION A	NOMINAL WALL
B7WWW-R100P	1"	1.125	0.065
B7WWW-R150P	1½"	1.656	0.065
B7WWW-R200P	2"	2.062	0.065
B7WWW-R250P	2½"	2.344	0.065
B7WWW-R300P	3"	2.594	0.065
B7WWW-R400P	4"	3.438	0.083

Polished 316L Stainless Steel.

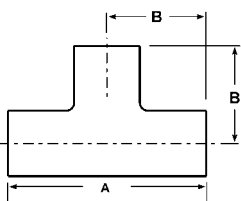

POLISHED TEES – BUTT WELD / LONG TEE – B7W

PART NO.	TUBE O.D.	DIMENSION		NOMINAL WALL
		A	B	
B7W-R50P	½"	3.750	1.875	0.065
B7W-R75P	¾"	4.000	2.000	0.065
B7W-R100P	1"	3.750	1.875	0.065
B7W-R150P	1½"	4.500	2.250	0.065
B7W-R200P	2"	6.000	3.000	0.065
B7W-R250P	2½"	6.000	3.000	0.065
B7W-R300P	3"	6.500	3.250	0.065
B7W-R400P	4"	7.750	3.875	0.083
B7W-R800P	8"	14.000	7.000	0.120

Polished 316L Stainless Steel.

POLISHED TEES – BUTT WELD / REDUCING TEE – B7RWWW

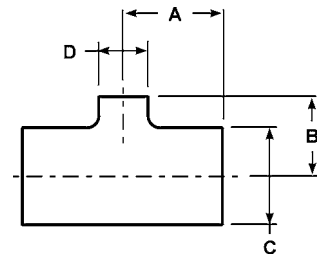

PART NO.	TUBE O.D.	DIMENSION				NOMINAL WALL
		A	B	C	D	
B7RWWW-R7550P	¾" x ½"	2.000	2.000	2.000	2.000	0.065
B7RWWW-R10050P	1" x ½"	2.125	2.125	2.125	2.125	0.065
B7RWWW-R10075P	1" x ¾"	2.125	2.125	2.125	2.125	0.065
B7RWWW-R15050P	1½" x ½"	2.375	2.375	2.375	2.375	0.065
B7RWWW-R15075P	1½" x ¾"	2.375	2.375	2.375	2.375	0.065
B7RWWW-R150100P	1½" x 1"	1.656	1.656	1.656	1.656	0.065
B7RWWW-R20050P	2" x ½"	2.875	2.875	2.875	2.875	0.065
B7RWWW-R20075P	2" x ¾"	2.875	2.875	2.875	2.875	0.065
B7RWWW-R200100P	2" x 1"	2.062	2.062	2.062	2.062	0.065
B7RWWW-R200150P	2" x 1½"	2.062	2.062	2.062	2.062	0.065
B7RWWW-R250150P	2½" x 1½"	2.344	2.344	2.344	2.344	0.065
B7RWWW-R250200P	2½" x 2"	2.344	2.344	2.344	2.344	0.065
B7RWWW-R300150P	3" x 1½"	2.594	2.594	2.594	2.594	0.065
B7RWWW-R300200P	3" x 2"	2.594	2.594	2.594	2.594	0.065
B7RWWW-R300250P	3" x 2½"	2.594	2.594	2.594	2.594	0.083
B7RWWW-R400150P	4" x 1½"	3.438	3.438	3.438	3.438	0.083
B7RWWW-R400200P	4" x 2"	3.438	3.438	3.438	3.438	0.083
B7RWWW-R400250P	4" x 2½"	3.438	3.438	3.438	3.438	0.083
B7RWWW-R400300P	4" x 3"	3.438	3.438	3.438	3.438	0.083
B7RWWW-R600200P	6" x 2"	5.625	5.625	5.625	5.625	0.109
B7RWWW-R600300P	6" x 3"	5.625	5.625	5.625	5.625	0.109
B7RWWW-R600400P	6" x 4"	5.625	5.625	5.625	5.625	0.109

Polished 316L Stainless Steel.

G

POLISHED REDUCERS – BUTT WELD CONCENTRIC REDUCER – B31W

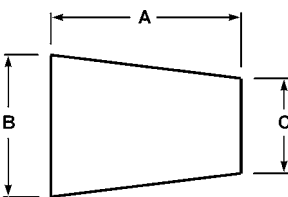

PART NO.	TUBE O.D.	DIMENSION			NOMINAL WALL
		A	B	C	
B31W-R7550P	¾" x ½"	1.000	0.750	0.500	0.065
B31W-R10050P	1" x ½"	2.000	1.000	0.500	0.065
B31W-R10075P	1" x ¾"	1.000	1.000	0.750	0.065
B31W-R15050P	1½" x ½"	4.000	1.500	0.500	0.065
B31W-R15075P	1½" x ¾"	3.000	1.500	0.750	0.065
B31W-R150100P	1½" x 1"	2.000	1.500	1.000	0.065
B31W-R20050P	2" x ½"	6.000	2.000	0.500	0.065
B31W-R20075P	2" x ¾"	5.000	2.000	0.750	0.065
B31W-R200100P	2" x 1"	4.000	2.000	1.000	0.065
B31W-R200150P	2" x 1½"	2.000	2.000	1.500	0.065
B31W-R250150P	2½" x 1½"	4.000	2.500	1.500	0.065
B31W-R250200P	2½" x 2"	2.000	2.500	2.000	0.065
B31W-R300100P	3" x 1"	8.000	3.000	1.000	0.065
B31W-R300150P	3" x 1½"	6.000	3.000	1.500	0.065
B31W-R300200P	3" x 2"	4.000	3.000	2.000	0.065
B31W-R300250P	3" x 2½"	2.000	3.000	2.500	0.065
B31W-R400150P	4" x 1½"	10.000	4.000	1.500	0.083
B31W-R400200P	4" x 2"	8.000	4.000	2.000	0.083
B31W-R400250P	4" x 2½"	6.000	4.000	2.500	0.083
B31W-R400300P	4" x 3"	4.000	4.000	3.000	0.083
B31W-R600200P	6" x 2"	5.500	6.000	2.000	0.109
B31W-R800400P	8" x 4"	6.000	8.000	4.000	0.120
B31W-R800600P	8" x 6"	6.000	8.000	6.000	0.120

Polished 316L Stainless Steel.

POLISHED REDUCERS – BUTT WELD ECCENTRIC REDUCER – B32W

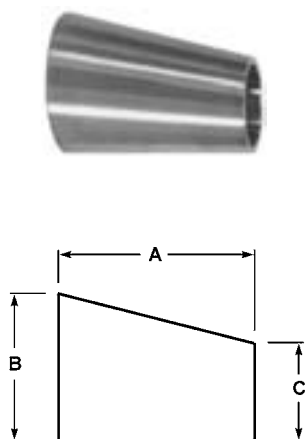

PART NO.	TUBE O.D.	DIMENSION			NOMINAL WALL
		A	B	C	
B32W-R7550P	¾" x ½"	1.000	0.750	0.500	0.065
B32W-R10050P	1" x ½"	2.000	1.000	0.500	0.065
B32W-R10075P	1" x ¾"	1.000	1.000	0.750	0.065
B32W-R15050P	1½" x ½"	4.000	1.500	0.500	0.065
B32W-R15075P	1½" x ¾"	3.000	1.500	0.750	0.065
B32W-R150100P	1½" x 1"	2.000	1.500	1.000	0.065
B32W-R20050P	2" x ½"	6.000	2.000	0.500	0.065
B32W-R20075P	2" x ¾"	5.000	2.000	0.750	0.065
B32W-R200100P	2" x 1"	4.000	2.000	1.000	0.065
B32W-R200150P	2" x 1½"	2.000	2.000	1.500	0.065
B32W-R250150P	2½" x 1½"	4.000	2.500	1.500	0.065
B32W-R250200P	2½" x 2"	2.000	2.500	2.000	0.065
B32W-R300150P	3" x 1½"	6.000	3.000	1.500	0.065
B32W-R300200P	3" x 2"	4.000	3.000	2.000	0.065
B32W-R300250P	3" x 2½"	2.000	3.000	2.500	0.065
B32W-R400150P	4" x 1½"	10.000	4.000	1.500	0.083
B32W-R400200P	4" x 2"	8.000	4.000	2.000	0.083
B32W-R400250P	4" x 2½"	6.000	4.000	2.500	0.083
B32W-R400300P	4" x 3"	4.000	4.000	3.000	0.083

Polished 316L Stainless Steel.

G

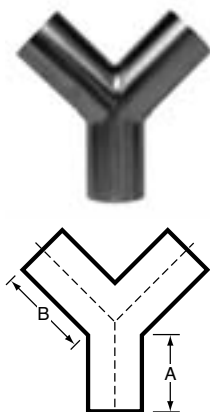

POLISHED TRUE (EQUAL) BUTT WELD "Y"

PART NO.	TUBE O.D.	DIMENSION		NOMINAL WALL
		A	B	
B28W-R100P	1"	2.000	2.438	0.065
B28W-R150P	1½"	2.000	2.438	0.065
B28W-R200P	2"	2.625	3.250	0.065
B28W-R250P	2½"	3.370	4.125	0.065
B28W-R300P	3"	4.000	4.875	0.065
B28W-R400P	4"	5.375	5.375	0.083

Polished 316L Stainless Steel.

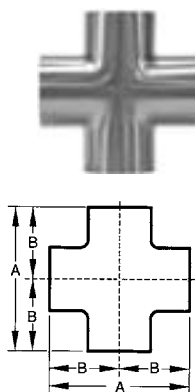

POLISHED TRUE (EQUAL) BUTT WELD "X"

PART NO.	TUBE O.D.	DIMENSION		NOMINAL WALL
		A	B	
B9WWWW-R100P	1"	2.250	1.125	0.065
B9WWWW-R150P	1½"	3.312	1.656	0.065
B9WWWW-R200P	2"	4.125	2.062	0.065
B9WWWW-R250P	2½"	4.687	2.343	0.065
B9WWWW-R300P	3"	5.187	2.593	0.065
B9WWWW-R400P	4"	6.875	3.437	0.083

Polished 316L Stainless Steel.

UK Dairy Standard Fittings. Polished OD, bright anealed or tumbled ID

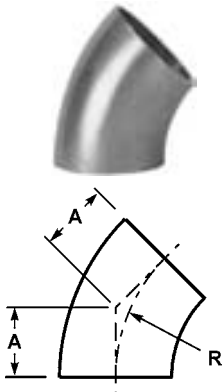

UK DAIRY ELBOWS LESS TANGENT – B2WK

PART NO.	TUBE O.D.	DIMENSION		NOMINAL WALL
		A	R	
B2WK-R1005	1"	15.8	38.1	1.6
B2WK-R1505	1½"	23.7	57.2	1.6
B2WK-R2005	2"	31.6	76.2	1.6
B2WK-R2505	2½"	39.5	95.5	1.6
B2WK-R3005	3"	47.3	114.3	1.6
B2WK-R4005	4"	63.1	152.4	2

OD polished only 316 stainless steel

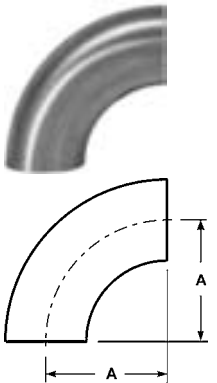

90° UK DAIRY ELBOWS – BUTT WELD ELBOWS LESS TANGENT – B2WCL

PART NO.	TUBE O.D.	DIMENSION A	NOMINAL WALL
B2WCL-R505	½"	19.1	1.6
B2WCL-R755	¾"	28.6	1.6
B2WCL-R1005	1"	38.1	1.6
B2WCL-R1505	1½"	57.2	1.6
B2WCL-R2005	2"	76.2	1.6
B2WCL-R2505	2½"	95.3	1.6
B2WCL-R3005	3"	114.3	1.6
B2WCL-R4005	4"	152.4	2

OD polished only 316 stainless steel

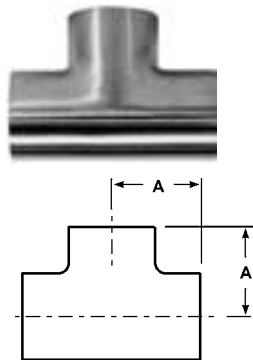

UK DAIRY TEES – BUTT WELD / SHORT TEE-B7WWW

PART NO.	TUBE O.D.	DIMENSION A	NOMINAL WALL
B7WWW-R505	½"	19.1	1.6
B7WWW-R755	¾"	28.6	1.6
B7WWW-R1005	1"	44	1.6
B7WWW-R1505	1½"	64	1.6
B7WWW-R2005	2"	89	1.6
B7WWW-R2505	2½"	114	1.6
B7WWW-R3005	3"	134	1.6
B7WWW-R4005	4"	195	2

OD polished only 316 stainless steel

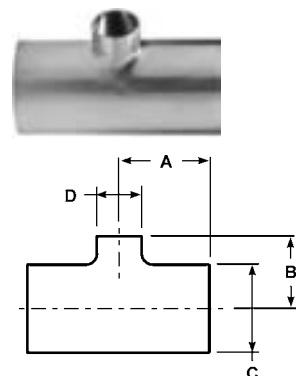

UK DAIRY TEES – BUTT WELD / REDUCING TEE – B7RWWW

PART NO.	TUBE O.D.	DIMENSION				NOMINAL WALL
		A	B	C	D	
B7RWWW-R100505	1" x ½"	50	27	25.4	12.7	1.6
B7RWWW-R1501005	1½" x 1"	75	21.6	38.1	25.4	1.6
B7RWWW-R150505	1½" x ½"	75	27	30.1	12.7	1.6
B7RWWW-R2001005	2" x 1"	89	28.9	50.8	25.4	1.6
B7RWWW-R2502005	2½" x 2"	95	35	63.5	50.8	1.6
B7RWWW-R4002005	4" x 2"	127	107	101.6	50.8	2

OD polished only 316 stainless steel

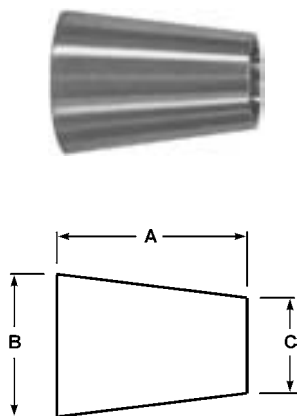

UK DAIRY REDUCERS – BUTT WELD CONCENTRIC REDUCER – B31W

PART NO.	TUBE O.D.	DIMENSION			NOMINAL WALL
		A	B	C	
B31W-R75505	¾" x ½"	19.1	19.1	12.7	1.6
B31W-R100505	1" x ½"	19.1	25.4	12.7	1.6
B31W-R100755	1" x ¾"	16	25.4	19.1	1.6
B31W-R150755	1½" x ¾"	31	38.1	19.1	1.6
B31W-R1501005	1½" x 1"	28	38.1	25.4	1.6
B31W-R2001505	2" x 1½"	31	50.8	38.1	1.6
B31W-R2001005	2" x 1"	49	50.8	25.4	1.6
B31W-R2502005	2½" x 2"	41	63.5	50.8	1.6
B31W-R2501505	2½" x 1½"	48	63.5	38.1	1.6
B31W-R2501005	2½" x 1"	76	63.5	25.4	1.6
B31W-R3002505	3" x 2½"	40	76.1	63.5	1.6
B31W-R3002005	3" x 2"	50	76.1	50.8	1.6
B31W-R3001505	3" x 1½"	74	76.1	38.1	1.6
B31W-R4003005	4" x 3"	51	101.6	76.1	2
B31W-R4002005	4" x 2"	100	101.6	50.8	2

OD polished only 316 stainless steel

G

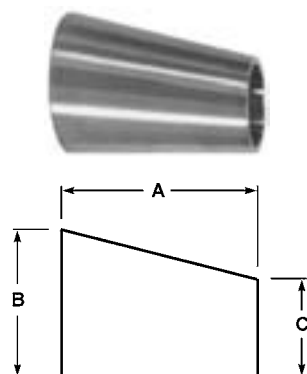

UK DAIRY REDUCERS – BUTT WELD ECCENTRIC REDUCER – B32W

PART NO.	TUBE O.D.	DIMENSION			NOMINAL WALL
		A	B	C	
B32W-R1501005	1½" x 1"	29	38.1	25.4	1.6
B32W-R2001005	2" x 1"	48	50.8	25.4	1.6
B32W-R2502005	2½" x 2"	44	63.5	50.8	1.6
B32W-R3002005	3" x 2"	46	76.1	50.8	1.6
B32W-R4002005	4" x 2"	91	101.6	50.8	2

OD polished only 316 stainless steel

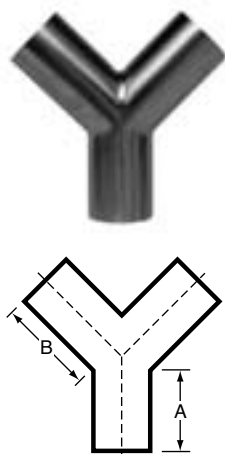

UK DAIRY TRUE (EQUAL) BUTT WELD "Y"

PART NO.	TUBE O.D.	DIMENSION		NOMINAL WALL
		A	B	
B28W-R1005	1"	76.2	76.2	1.6
B28W-R1505	1½"	76.2	76.2	1.6
B28W-R2005	2"	101.6	101.6	1.6
B28W-R2505	2½"	127	127	1.6
B28W-R3005	3"	152.4	152.4	1.6
B28W-R4005	4"	203.2	203.2	2

OD polished only 316 stainless steel

Bradford™ High Purity BioPharm Fittings

Dixon Group Europe's range of high purity BioPharm fittings comply with ASME BPE-2009-Table DT-5-1.



BPE Table #DT-7

90° ELBOWS			
PL Finish - SF1	PM Finish - SF4	Size	A
T2S-050PL	T2S-050PM	½"	3.00
T2S-075PL	T2S-075PM	¾"	3.00
T2S-100PL	T2S-100PM	1"	3.00
T2S-150PL	T2S-150PM	1½"	3.75
T2S-200PL	T2S-200PM	2"	4.75

Also offered clamp end.



BPE Table #DT-8

45° ELBOWS			
PL Finish - SF1	PM Finish - SF4	Size	A
T2KS-050PL	T2KS-050PM	½"	2.250
T2KS-075PL	T2KS-075PM	¾"	2.250
T2KS-100PL	T2KS-100PM	1"	2.250
T2KS-150PL	T2KS-150PM	1½"	2.500
T2KS-200PL	T2KS-200PM	2"	3.000

Also offered clamp end.

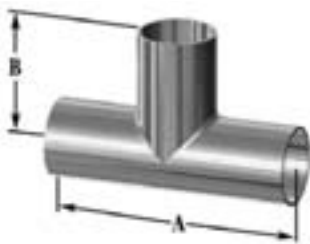

BPE Table #DT-9

TEES				
PL Finish - SF1	PM Finish - SF4	Size	A	B
T7WWW-050PL	T7WWW-050PM	½"	3.750	1.875
T7WWW-075PL	T7WWW-075PM	¾"	4.000	2.000
T7WWW-100PL	T7WWW-100PM	1"	4.250	2.125
T7WWW-150PL	T7WWW-150PM	1½"	4.750	2.375
T7WWW-200PL	T7WWW-200PM	2"	5.750	2.875

Also offered clamp end.

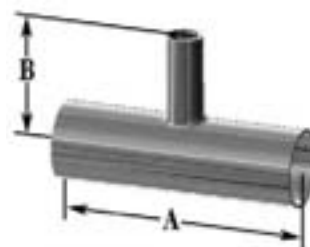

BPE Table #DT-10

REDUCING TEES				
PL Finish - SF1	PM Finish - SF4	Size	A	B
T7RWWW-075050PL	T7RWWW-075050PM	¾" x ½"	4.000	2.000
T7RWWW-100050PL	T7RWWW-100050PM	1" x ½"	4.250	2.125
T7RWWW-100075PL	T7RWWW-100075PM	1" x ¾"	4.250	2.125
T7RWWW-150050PL	T7RWWW-150050PM	1½" x ½"	4.750	2.375
T7RWWW-150075PL	T7RWWW-150075PM	1½" x ¾"	4.750	2.375
T7RWWW-150100PL	T7RWWW-150100PM	1½" x 1"	4.750	2.375
T7RWWW-200050PL	T7RWWW-200050PM	2" x ½"	5.750	2.625
T7RWWW-200075PL	T7RWWW-200075PM	2" x ¾"	5.750	2.625
T7RWWW-200100PL	T7RWWW-200100PM	2" x 1"	5.750	2.625
T7RWWW-200150PL	T7RWWW-200150PM	2" x 1½"	5.750	2.625

Also offered clamp end.

PL Finish – SF1

PM Finish – SF4

OD = 32Ra Mechanically Polished

OD = 32Ra Mechanically Polished

ID = 20Ra Mechanically Polished

ID = 15Ra Mechanically Polished and Electropolished

Dixon Group Europe's range of high purity BioPharm fittings comply with ASME BPE-2009-Table DT-5-1.



BPE Table #DT-11

CONCENTRIC REDUCERS			
PL Finish - SF1	PM Finish - SF4	Size	A
T31W-075050PL	T31W-075050PM	¾" x ½"	4.00
T31W-100050PL	T31W-100050PM	1" x ½"	4.50
T31W-100075PL	T31W-100075PM	1" x ¾"	4.00
T31W-150050PL	T31W-150050PM	1½" x ½"	5.50
T31W-150075PL	T31W-150075PM	1½" x ¾"	5.00
T31W-150100PL	T31W-150100PM	1½" x 1"	5.00
T31W-200050PL	T31W-200050PM	2" x ½"	7.75
T31W-200075PL	T31W-200075PM	2" x ¾"	7.25
T31W-200100PL	T31W-200100PM	2" x 1"	7.25
T31W-200150PL	T31W-200150PM	2" x 1½"	5.25

Also offered clamp end.

G



BPE Table #DT-11

ECCENTRIC REDUCERS			
PL Finish - SF1	PM Finish - SF4	Size	A
T32W-075050PL	T32W-075050PM	¾" x ½"	4.00
T32W-100050PL	T32W-100050PM	1" x ½"	4.50
T32W-100075PL	T32W-100075PM	1" x ¾"	4.00
T32W-150050PL	T32W-150050PM	1½" x ½"	5.50
T32W-150075PL	T32W-150075PM	1½" x ¾"	5.00
T32W-150100PL	T32W-150100PM	1½" x 1"	5.00
T32W-200050PL	T32W-200050PM	2" x ½"	7.75
T32W-200075PL	T32W-200075PM	2" x ¾"	7.25
T32W-200100PL	T32W-200100PM	2" x 1"	7.25
T32W-200150PL	T32W-200150PM	2" x 1½"	5.25

Also offered clamp end.



BPE Table #DT-22

AUTO WELD FERRULES			
PL Finish - SF1	PM Finish - SF4	Size	A
TL14AM7-050PL	TL14AM7-050PM	½"	1.75
TL14AM7-075PL	TL14AM7-075PM	¾"	1.75
TL14AM7-100PL	TL14AM7-100PM	1"	1.75
TL14AM7-150PL	TL14AM7-150PM	1½"	1.75
TL14AM7-200PL	TL14AM7-200PM	2"	2.25
TL14AM7-250PL	TL14AM7-250PM	2½"	2.25
TL14AM7-300PL	TL14AM7-300PM	3"	2.25
TL14AM7-400PL	TL14AM7-400PM	4"	2.25

Also offered clamp end.

PL Finish – SF1

OD = 32Ra Mechanically Polished

ID = 20Ra Mechanically Polished

Electropolished

PM Finish – SF4

OD = 32Ra Mechanically Polished

ID = 15Ra Mechanically Polished and

Clamps Accessories

Service pressure ratings are based on the following parameters: matching elastomer gaskets and weld ferrules properly aligned and assembled with the clamps tightened to the required torques. Tests are done hydrostatically with no water hammer or shock loads. Please note the pressure ratings of the described unions are above the recommended pipe line operating pressures.



SINGLE PIN HEAVY DUTY CLAMPS WITH CROSS HOLE WING NUT - 13MHHM - 316				
Part Number	Tube OD	Service Pressure Rating @ 21°C (70°F)*	Service Pressure Rating @ 121°C (250°F)*	A
13MHHM-R100150	1" - 1½"	500	300	2.122
13MHHM-R200	2"	450	250	2.654
13MHHM-R250	2½"	400	200	3.185
13MHHM-R300	3"	350	175	3.717
13MHHM-R400	4"	300	150	4.820

*wing nut tightened to 25in. lb of torque



SINGLE PIN HEAVY DUTY CLAMPS WITH CROSS HOLE WING NUT - 13MHHM - 304				
Part Number	Tube OD	Service Pressure Rating @ 21°C (70°F)*	Service Pressure Rating @ 121°C (250°F)*	A
13MHHM50-75	½" - ¾"	1500	1200	1.062
13MHHM100-150	1" - 1½"	500	300	2.122
13MHHM200	2"	450	250	2.654
13MHHM250	2½"	400	200	3.185
13MHHM300	3"	350	175	3.717
13MHHM400	4"	300	150	4.820

*wing nut tightened to 25in. lb of torque

G



PTFE GASKETS	
PART NO.	SIZE
42MP-G50	½"
42MP-G75	¾"
40MP-G100	1"
40MP-G150	1½"
40MP-G200	2"
40MP-G250	2½"
40MP-G300	3"
40MP-G400	4"

- Colour code: no dot
- Meets 21CFR 177.1550
- Passed U.S.P. Class VI Cytotoxicity testing
- Not recommended for use with bolted clamps

CAUTION

PTFE is a material subject to plastic flow. When cycled through heat and then cooled down in process lines, PTFE gaskets will not return to the original configuration and it will continue to compress as the cycling continues. This plastic flow will allow leakage if clamp torques are not maintained.

FOR FULL TECHNICAL BIOPHARM DETAILS SEE PAGES 495-497

High Purity BioPharm Aseptic Diaphragm Valve

Our product offering of standard 2-way valves, innovative custom fabrications and modular block body designs solve the more demanding process problems.

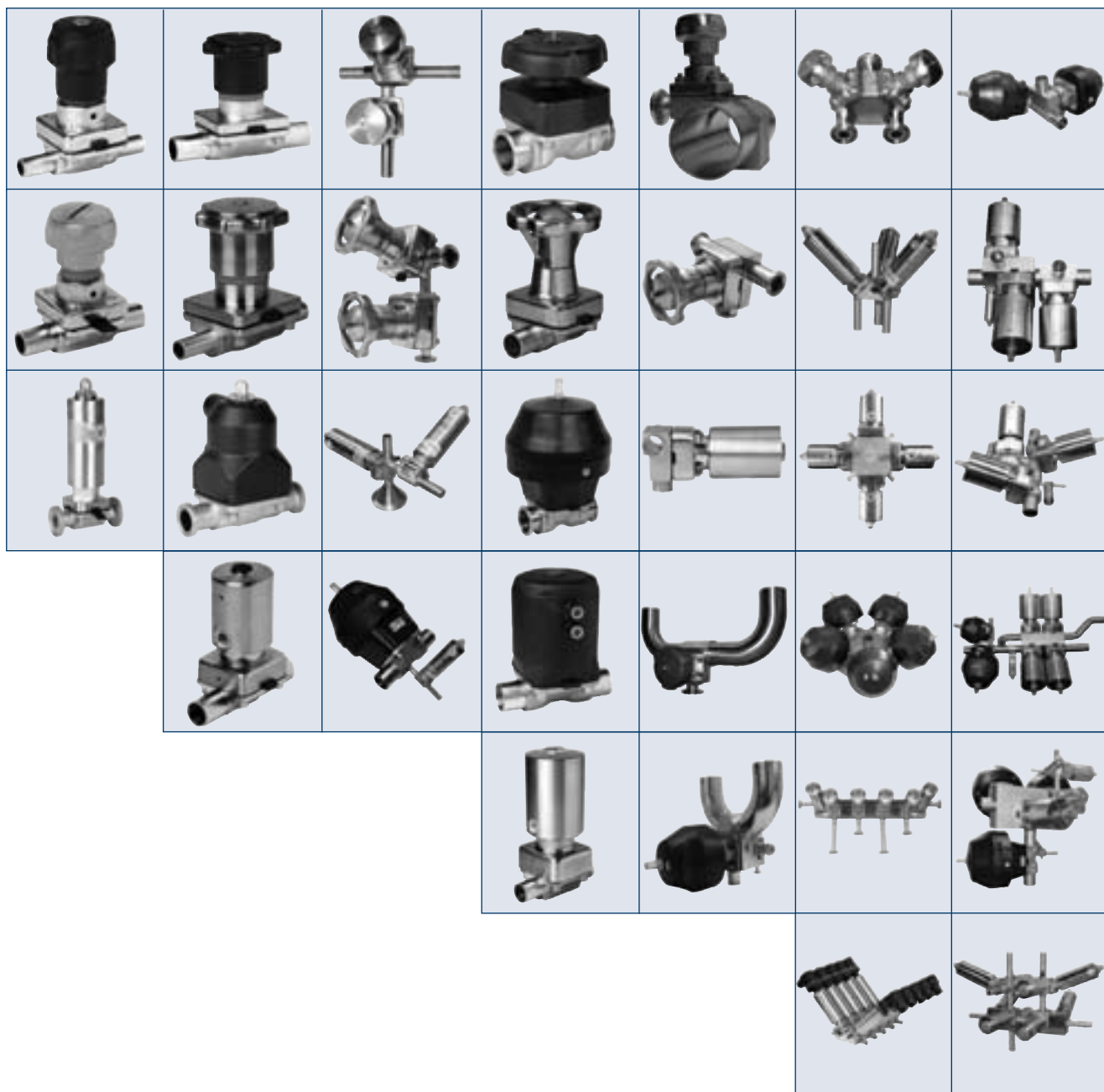

G

Features:

- Quick turn around
- 3D models
- Application engineering service

Applications:

Pharmaceutical, bio-processing, cosmetics, food and beverage, fine chemicals and semiconductor industries where aseptic and hygienic conditions are required.

Processes:

Highly sterile media, ultra-pure water, WFI (Water for Injection), ultra-pure chemicals, intermediate and end products in the pharmaceutical and bio-processing industries.

Features:

Sterile, reduced contact surface and hold up volume, easily drained, elimination of cross contamination and customer-specific process designs.

Sight Glasses

Product Specifications

- Size range:** • 1" - 6" OD
- Materials:** • 316L stainless steel
• Borosilicate glass
- Finish:** • 3A sanitary finish ID and OD

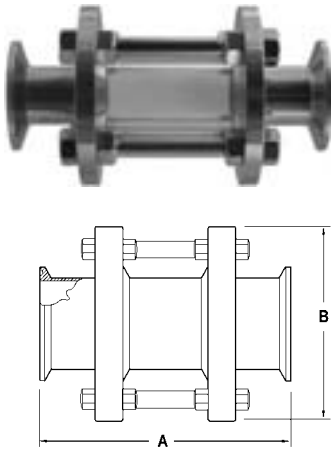

IN-LINE SIGHT GLASS - B54BMP				
PART NO.	TUBE OD	A	B	WORKING PRESSURE
B54BMP-R100	1"	5.625	3.250	145
B54BMP-R150	1½"	5.625	4.000	145
B54BMP-R200	2"	5.625	4.250	145
B54BMP-R250	2½"	6.125	4.750	120
B54BMP-R300	3"	7.250	5.500	120
B54BMP-R400	4"	7.375	6.500	95
B54BMP-R600	6"	7.625	9.500	80

- made with borosilicate (Pyrex®) glass with white buna gaskets
- various end configurations are available: clamp, weld, RJT, DIN, IDF, SMS
- maximum temperature: (200°F) 93°C

G

KITS AND REPLACEMENT PARTS

SIZE	SEAL KIT PART NUMBER	REPLACEMENT GLASS PART NUMBER	SIZE	SEAL KIT PART NUMBER	REPLACEMENT GLASS PART NUMBER
1"	B54BMP-SK100	B54G-P100	3"	B54BMP-SK300	B54G-P300
1½"	B54BMP-SK150	B54G-P150	4"	B54BMP-SK400	B54G-P400
2"	B54BMP-SK200	B54G-P200	6"	B54BMP-SK600	B54G-P600
2½"	B54BMP-SK250	B54G-P250			

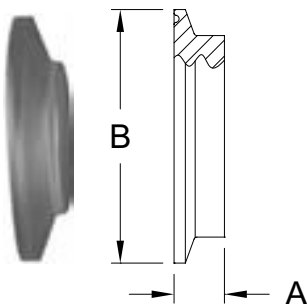

END CAPS – B5416MP			
PART NO.	TUBE OD	DIMENSIONS	
		A	B
B5416MP-A100150	1½"	0.438	1.984
B5416MP-A200	2"	0.438	2.516
B5416MP-A250	2½"	0.438	3.047
B5416MP-A300	3"	0.438	3.579
B5416MP-A400	4"	0.438	4.682
B5416MP-A600	6"	0.438	6.562

- For use on any line with a clamp and gasket
- Acrylic plastic
- Maximum temperature: (150°F) 66°C
- Maximum operating pressure: 100 PSI

Pipe Hangers

Support Recommendations

- Lines are not to be rigidly anchored to equipment. Lines must be allowed to float. Temperatures cause expansion and contraction and if mounted incorrectly will cause distortion and possibly leakage.

- Proper Installation:
 - Straight sections need support every 10 feet / 3 metres
 - Each side of every valve (as close as possible to the connection) needs support
 - Support at each change of direction

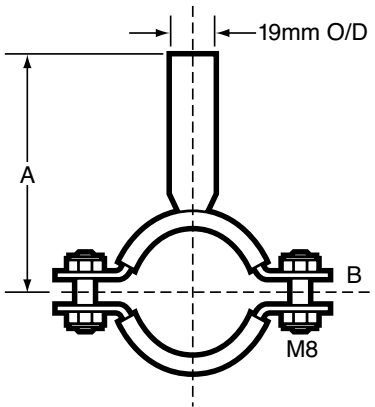

SADDLE CLIP			
Part No	Size	A	B
B24DB-G050	1/2"	90	3
B24DB-G100	1"	90	3
B24DB-G150	1 1/2"	90	3
B24DB-G200	2"	90	3
B24DB-G250	2 1/2"	90	3
B24DB-G300	3"	90	3
B24DB-G400	4"	90	3

G

BLOCK STYLE TUBE HANGERS - B24

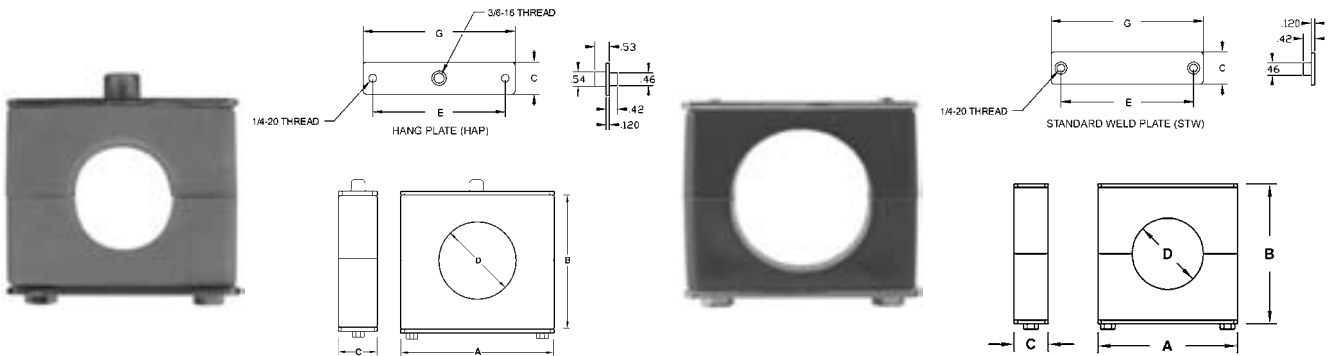

TUBE O.D.	HANG PLATE DESIGN							WELD PLATE DESIGN			
	A	B	C	D	E	F	G	HANG PLATE Polypropylene Number	STANDARD WELD PLATE Polypropylene Number	HANG PLATE Santoprene Number	STANDARD WELD PLATE Santoprene Number
1/2"	47.75	35.05	30.23	33.02	52.32	50.29	88.90	B24PPHAP-G50	B24PPSTW-G50	B24SPHAP-G50	B24SPSTW-G50
3/4"	47.75	35.05	30.23	33.02	52.32	50.29	88.90	B24PPHAP-G75	B24PPSTW-G75	B24SPHAP-G75	B24SPSTW-G75
1"	84.84	66.80	30.23	66.04	85.60	88.14	123.95	B24PPHAP-G100	B24PPSTW-G100	B24SPHAP-G100	B24SPSTW-G100
1 1/2"	84.84	66.80	30.23	66.04	85.60	88.14	123.95	B24PPHAP-G150	B24PPSTW-G150	B24SPHAP-G150	B24SPSTW-G150
2"	84.84	66.80	30.23	66.04	85.60	88.14	123.95	B24PPHAP-G200	B24PPSTW-G200	B24SPHAP-G200	B24SPSTW-G200
2 1/2"	127.00	111.25	30.23	107.95	127.76	139.70	165.10	B24PPHAP-G250	B24PPSTW-G250	B24SPHAP-G250	B24SPSTW-G250
3"	127.00	111.25	30.23	107.95	127.76	139.70	165.10	B24PPHAP-G300	B24PPSTW-G300	B24SPHAP-G300	B24SPSTW-G300
4"	146.56	121.92	30.23	125.73	146.56	146.05	165.10	B24PPHAP-G400	B24PPSTW-G400	B24SPHAP-G400	B24SPSTW-G400

- Santoprene - FDA approved material, maximum temperature 302°F (SP) / 150°C
- Polypropylene - maximum temperature 212°F (PP) / 100°C

Hygienic Pressure Gauges

Full Range of Diaphragm Pressure Gauges. Stainless Steel construction filled with a FDA compliant, non-toxic gel media.

Used in Food, Pharmaceutical and Chemical applications.

Features: 100 mm (4") Gauge as standard. Other sizes available. Temperature compensated between -12 and 120°C.

Accurate to + or - 1 % full-scale deflection. All Gauges supplied with a calibration certificate.

Diaphragm seal can be supplied with "wetted" or media contact parts in Stainless Steel, Hastelloy®, Monel® etc.

For specific applications, price and availability, please contact Dixon.



Connections / Fittings: RJT, IDF, DIN, SMS, TRI-CLAMP.

Call us for other connections.

Spray Balls

Product Specifications

Size range: • ¾" and 1½" NPT • 1" and 1½" OD tube • 1½" clamp

Materials: • 304 stainless steel • 316L stainless steel

Finish: • 3A mirror-like finish (ID/OD)

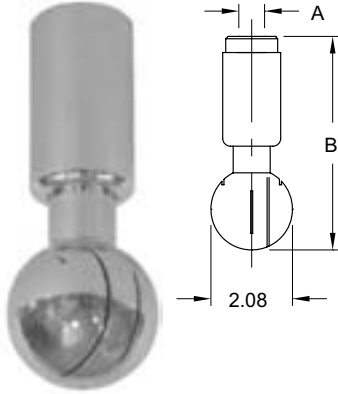

ROTATING SPRAY BALLS - SRH					
304 STAINLESS STEEL PRODUCT NUMBER	316L STAINLESS STEEL PRODUCT NUMBER	SIZE	TYPE	A	B
SRH360NPT-G075	---	¾"	NPT	¾" NPT	5.46
---	SRH360NPT-R150	1½"	NPT	1½" NPT	5.46
SRH360CMP-G150	SRH360CMP-R150	1½"	Clamp	1.984	5.46

- 304 / 316L stainless steel
- stainless steel ball bearings to eliminate rust
- ideal for cleaning all types of tanks and vessels
- cleaning solution used to lubricate unit
- connections available: clamp and NPT
- mirror-like finish (ID/OD)
- spray pattern: 360°

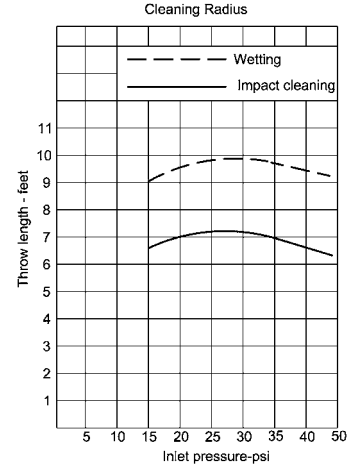
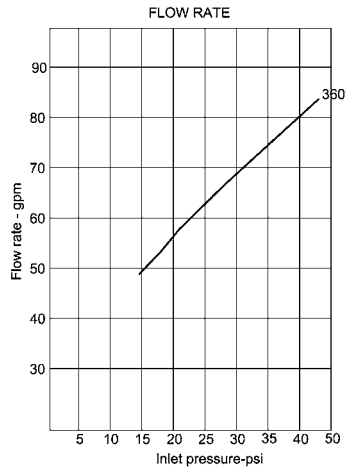

G



STATIONARY SPRAY BALLS - STC					
304 STAINLESS STEEL PRODUCT NUMBER	SIZE	SPRAY PATTERN	A	B	C
STC-360-R100	1"	360°	3.04	2.45	1.005
STC-360-R150	1½"	360°	3.54	2.95	1.505
STC-180B-R100	1"	180° bottom	3.54	2.95	1.005
STC-180B-R150	1½"	180° bottom	3.54	2.95	1.505
STC-180T-R100	1"	180° top	3.54	2.95	1.005
STC-180T-R150	1½"	180° top	3.54	2.95	1.505

- various spray patterns available, (blanks available as special order)
- stationary - designed to be mounted to a tube or pipe

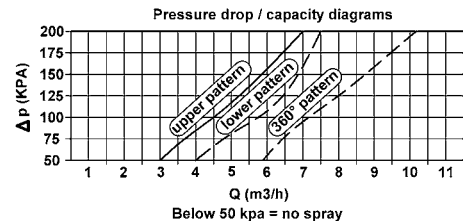
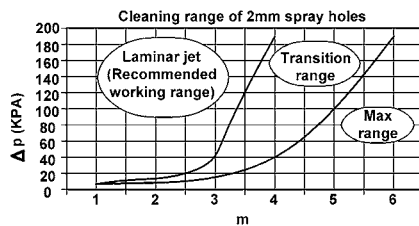
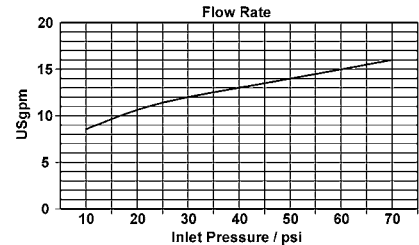
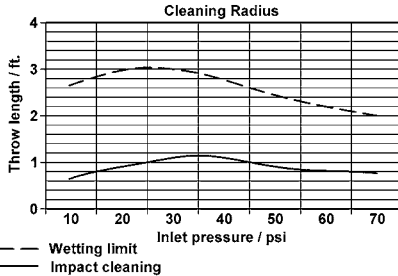

Check Valves



Size range: 1/2" - 4" O.D. (12-100mm)

Materials: R=316L

Contact Dixon for price and availability.

Maintaining the standard.

The Hygienic Standard was created by the dairy industry as a voluntary benchmark for product performance and hygienic safety.

Our products have earned the  symbol, which requires an annual assessment to make certain each product conforms in all respects to the published standard. Dixon check valves carrying the symbol conform to the hygienic standards for fittings for milk and milk products. Dixon is proud to be a participant in the  program.



A variety of industries have trusted Dixon hygienic check valves for many years. Dixon check valves feature quick-disconnect clamp ends for quick and easy cleaning (RJT, DIN, SMS, IDF ends available). Check valves are used for hygienic, as well as industrial applications, to prevent backflow.

- Spring check valves are designed to prevent reverse flow. Concentric valves are available in 1/2" - 4"
- Ball check valves are used where full flow and low pressure drop of product during processing is required. When the flow of product is reversed, the PTFE ball rolls back and seats, thus preventing backflow. Sizes are available from 1 1/2" - 3"
- Air blow check valves are used to clear lines of CIP solutions or other products. Sizes are available from 1" - 4"

Spring Check Valves

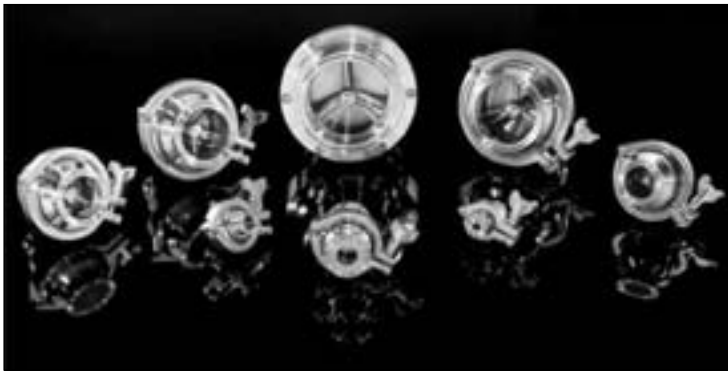

Get control with Dixon's high quality spring check valves. Spring check valves meet all 3A requirements and are designed to prevent reverse flow.

The valve opens once the pressure below the valve seat exceeds the pressure above the valve seat. It closes when the pressure is equalised.

- CF-8M (316) stainless steel
- Viton® seats
- Various end configurations available
- Full size flow plate with a long bushing helps to minimise stem wear
- Specially designed to prevent even low-pressure leak-through
- Maximum operating pressure: 145 psi
- Operating temperature range: 20°C (0°F) to 100°C (200°F)

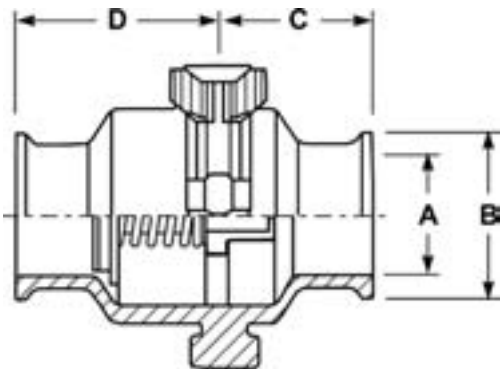
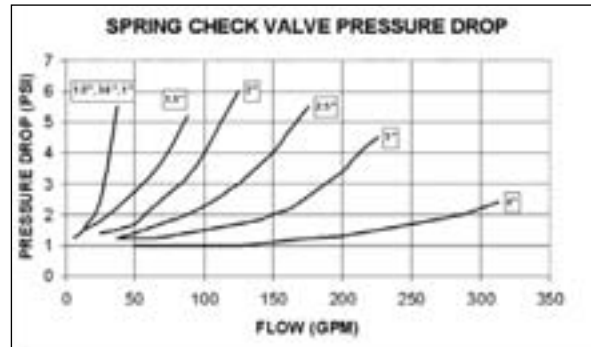

PART NO.	SIZE	DIMENSIONS (inches)				PRESSURE RATING (PSI)	CRACKING PRESSURE (PSI)		FLOW COEFFICIENT (CV)
		A	B	C	D		SPRING #1	SPRING #2	
B45MP-R50	1/2"	0.370	0.992	1.1	1.6	145	10	0.6	5
B45MP-R75	3/4"	0.620	0.992	1.1	1.6	145	4	2	8
B45MP-R100	1"	0.870	1.988	1.7	2.3	145	0.8	N/A	12
B45MP-R150	1 1/2"	1.370	1.988	1.7	2.3	145	1.6	N/A	20
B45MP-R200	2"	1.870	2.519	1.7	2.3	145	1.4	N/A	40
B45MP-R250	2 1/2"	2.370	3.051	1.7	2.3	145	0.9	N/A	60
B45MP-R300	3"	2.870	3.582	1.7	2.3	145	0.5	N/A	100
B45MP-R400	4"*	3.834	4.682	1.7	2.7	145	0.5	N/A	210

* 4" uses bolted construction in place of clamp

Note: Drawing is for dimensional information only. Specifications and dimensions are subject to change without notice.

Ball Check Valves



These rugged valves are designed to prevent reverse flow in systems moving liquid products.

When liquid flows into the inlet, a PTFE ball rolls up into the branch of the valve allowing full fluid flow. When the flow stops, equalising the pressure, the ball drops back into the seat, preventing backflow. Should reverse flow occur, the opposing pressure will cause the ball to seat firmly against the inlet gasket preventing backflow.

- Two piece construction for easier alignment during installation
- Various end configurations available: RJT, DIN, SMS, IDF, Clamp.
- Polished ID and OD to 3A standards
- Sizes from 1 1/2" - 3"
- All metal contact surfaces of 316 (CF8M) stainless steel construction
- Air blow check valve can be added (see air blow for sizing) page 186.
- PTFE ball

SIZE	COMPONENT SIZE (in)				BALL Ø	SEATING PRESSURE (inches) H2O	WEIGHT (lbs)
	BODY	CAP	CLAMP	GASKET			
1 1/2"	1 1/2"	2	2	2	1.6	0.75	4.9
2"	2"	2 1/2"	2 1/2"	2 1/2"	2.1	0.75	6.6
2 1/2"	2 1/2"	3"	3"	3"	2.7	0.75	10.5
3"	3"	4"	4"	4"	3.6	0.75	17.5

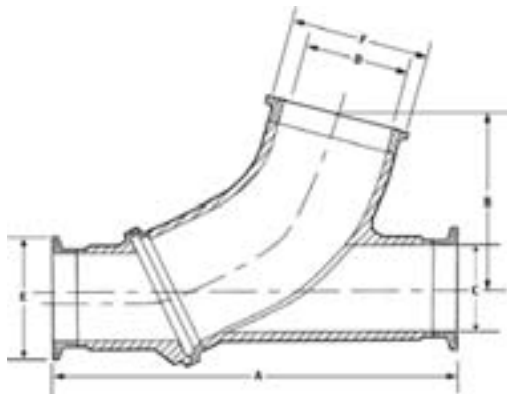

PART NO.	SIZE	DIMENSIONS (inches)					
		A	B	C	D	E	F
B45BY-R150	1 1/2"	7.5	3.3	1.365	1.875	1.984	2.516
B45BY-R200	2"	8.5	3.9	1.865	2.335	2.516	3.047
B45BY-R250	2 1/2"	10.0	4.5	2.370	2.870	3.047	3.579
B45BY-R300	3"	11.5	5.3	2.870	3.834	3.579	4.682

Note: Drawing is for dimensional information only. Specifications and dimensions are subject to change without notice.

Air Blow Check Valve



Dixon's air blow check valve is designed to evacuate lines of product or CIP solutions thus helping to protect the lines against corrosion. The valve's fail-safe operation prevents backflow with a simple air-to-open spring-to-close mechanism.

Attach and use with Dixon ball check valves, or any quick disconnect clamp configuration, to allow quick assembly and disassembly when replacing filter media, cleaning or inspecting.

FOR USE ON BALL CHECK VALVES:	
BALL CHECK VALVE SIZE	AIR BLOW VALVE SIZE
1 1/2"	2"
2"	2 1/2"
2 1/2"	3"
3"	4"

- 316L stainless steel offered with EPDM stem seat and gasket
- Sizes from 1 1/2" - 4"
- Conforms to 3A standards for filtration of air entering tanks or pipelines with optional filter disc
- Filter discs sold separately in packs of 50

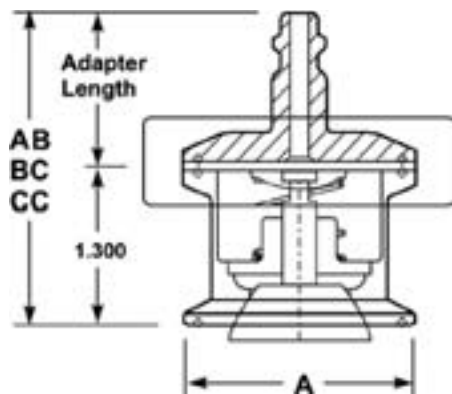

PART NO.	SIZE	DIMENSIONS (inches)			
		A	AB	BC	CC
B45AB-R100150	1 - 1 1/2"	1.984	2.550	2.989	1.925
B45AB-R200	2"	2.516	2.550	2.989	1.925
B45AB-R250	2 1/2"	3.047	2.550	2.989	1.925
B45AB-R300	3"	3.579	2.550	2.989	1.925
B45AB-R400	4"	4.682	2.550	2.989	1.925

- Note:
- * AB dimension reflects valve length and quick coupler adapter (B16AC) - (standard)
 - * BC dimension reflects valve length and hose barb adapter (14MPHR)
 - * CC dimension reflects valve length and NPT adapter (B23BMP)

Note: Drawing is for dimensional information only. Specifications and dimensions are subject to change without notice.

Air Relief Valves



Working Principle

The Bradford™ air relief valve allows air to be removed from a line or container without the liquid flowing out. Its design does not allow air to enter the line or container, even if subjected to a negative pressure. It is a double-seated valve with a freely moving polypropylene ball. The ball, which is lighter than water, closes against the upper or lower seat, depending on the pressure conditions.

Get control with the dependable air relief valve which can be installed vertically on top of a tank, container or tube where air removal is required.

Examples:

1. Bleeding of a tube line where an air pocket has formed. This application calls for installation at the top of the tube.
2. Bleeding of a tube on the suction side of a pump. The suction side is bled automatically, before the pump starts, establishing a vacuum. Binding of air to liquid will be prevented, and so will subsequent cavitation. In this application the valve is mounted in front of the pump, on the top of the inlet tube.

Features and Benefits

- No tools for assembly or disassembly
- The ball and gaskets are replaceable
- The valve seals for both pressure and vacuum. The air and water can be directed away by using a plastic tube and the 1/8" FNPT connection port on the valve
- All product contact surfaces have a radius of 1/4" or better
- The valve ball is constructed of FDA, 3A approved polypropylene
- PTFE valve ball is available (density=0.078 lb/in³)
- Other gasket materials available

G

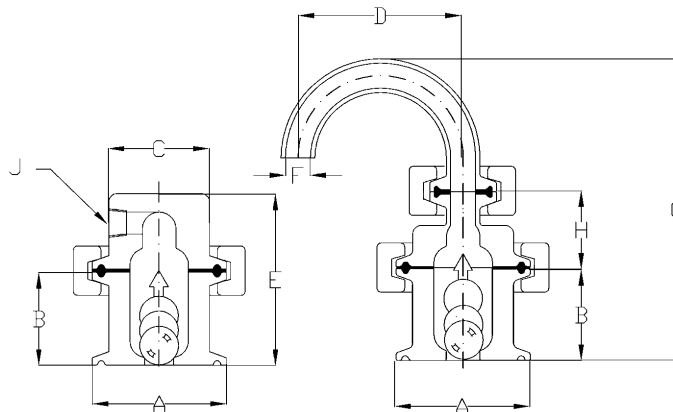

PART NO.	DESCRIPTION	DIMENSIONS (inches)								
		A	B	C	D	E	F	G	H	J
BARV-G150	air relief valve	1.98	1.4	1.5	-	2.4	-	-	-	1/8" NPT
BARVE-G150	3A air relief valve	1.98	1.4	-	1.5	-	0.37	4.5	1.1	-

Note: all dimensions are in inches. Dimensions are approximate. Engineering dimensions are available upon request. Specifications are subject to change without notice.

Ball Valves

Size Range: 1/2" - 4" O.D. (12 - 100mm)

Materials: (316) CF8M

Type of ends available: Clamp, Butt weld, RJT, DIN, SMS, IDF (other optional end connections available)

Contact your Dixon distributor for price and availability.



G

Businesses from food and beverage to pharmaceutical and cosmetics have trusted Dixon Hygienic ball valves for many years. The reason: Dixon Hygienic has the quality valves they need.

Ball valves are available in 1/2" - 4" and in various end connections such as triclamp, butt-weld, RJT, DIN, SMS, and IDF. Call for delivery as these ends are special order. Actuation is available in double acting, air-to-spring and electric. Please call for delivery as availability varies according to the requirements.

The Hygienic Standard was created by the dairy industry as a voluntary benchmark for product performance and hygienic safety. The standard, developed in collaboration by a group of processors, suppliers, regulatory officials and sanitation specialists, is generally accepted by regulatory authorities.

Our products have earned the  , which requires an annual assessment to make certain each product conforms in all respects to the published standard. Dixon ball valves carrying the symbol conform to the hygienic standards for valves for milk and milk products (#68-00).

Dixon Hygienic is proud to be a participant in the programme and maintaining the standard.

2-Way 3-piece Encapsulated Ball Valve



The Dixon ball valve is designed as a three piece construction with swing out centre section for easy field repair and cleaning in place. Operating parts are stainless steel type CF8M (316) conforming to ASTM A351, solution annealed and passivated for corrosion resistance.

The ball is fully encapsulated to eliminate cavities for bacteria to form. Live loaded stem packing provides a leak proof design which allows time for scheduled maintenance. The full port design creates less turbulence and is self draining. Elevated, integral ISO 5211 mounting pad is part of the valve design making actuation easy without any custom brackets. The handle makes this suitable for lock-out / tag-out applications.

- ID is polished to 3A or better
- Blow-out-proof stem design
- Various ends available: clamp, butt weld, RJT, DIN, SMS, AND IDF
- Live loaded stem packing
- Direct mount actuation: double, air to spring, and electric
- Rated at 1,000 PSI WOG (water, oil and gas), most applications

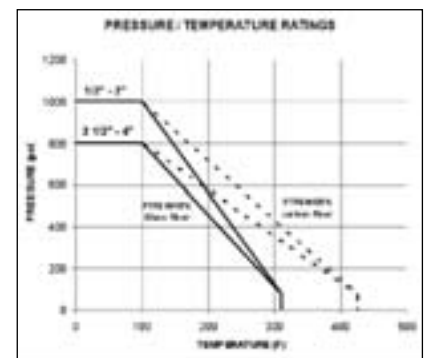
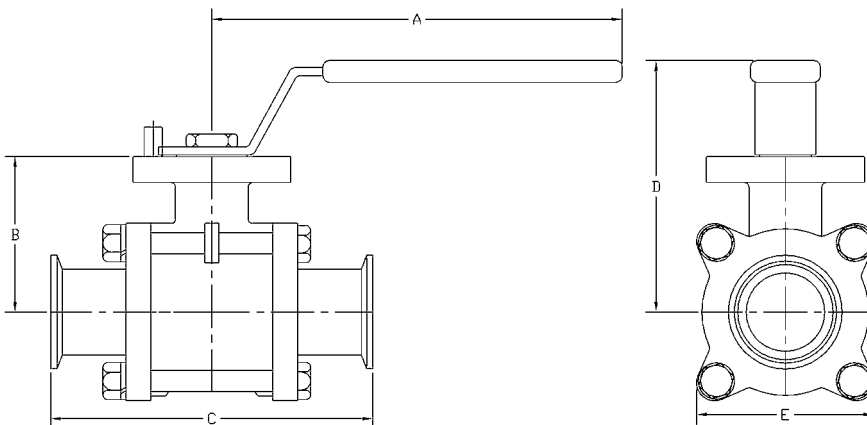

PART NO.	SIZE	DIMENSIONS (inches)					ASSEMBLY TORQUE (lbs)	BREAK TORQUE (lbs)	WEIGHT (lbs)
		A	B	C	D	E			
BV2C*-050CC-A	1/2"	4.7	1.5	4.3	3	1.9	160	50	1.5
BV2C*-075CC-A	3/4"	4.7	1.8	4.7	3.3	2.2	160	25	1.9
BV2C*-100CC-A	1"	5.2	2.1	4.9	3.6	2.4	160	90	2.7
BV2C*-150CC-A	1 1/2"	7.2	2.7	5.6	4.4	3.1	200	110	4.8
BV2C*-200CC-A	2"	7.2	3.1	6.4	4.8	3.7	212	300	8.9
BV2C*-250CC-A	2 1/2"	14.6	3.8	7.8	5.2	4.8	221	400	18.7
BV2C*-300CC-A	3"	15.7	4.2	9.0	5.7	5.4	239	550	29.7
BV2C*-400CC-A	4"	15.7	5.3	9.5	6.8	8.8	266	750	43.6

* See seat material options chart on page 190.

All dimensions are in inches. Dimensions are approximate. Engineering dimensions are available upon request.

Specifications are subject to change without notice.

Encapsulated 2-way 3 Piece Stainless Steel Ball Valve

Materials List for BV2C

ITEM	DESCRIPTION	MATERIAL	QUANTITY			
			1/2" - 2"	2 1/2"	3"	4"
1	body	ASTM A351-CF8M	1	1	1	1
2	end (4-bolt)	ASTM A351-CF8M	2	2	2	n/a
2A	end (6-bolt)	ASTM A351-CF8M	n/a	n/a	n/a	2
3	ball	ASTM A351-CF8M	1	1	1	1
4	seat (encapsulated)	see chart below	2	2	2	2
4A	seat (nonencap.)	see chart below	n/a	n/a	n/a	n/a
5	stem	see chart below	1	1	1	1
6	thrust washer	see chart below	1	1	1	1
7	O-ring	RTF	1	1	1	1
8	stem packing	see chart below	*	3	3	3
9	ring	AISI 316	1	1	1	1
10	bevel washer	AISI 301	3	3	3	3
11	hex nut	AISI 304	4	4	8	12
12	bolt washer	AISI 304	4	4	8	12
13	nut	AISI 304	2	2	2	2
14	bolt	AISI 304	4	4	n/a	n/a
14A	bolt (double thread)	AISI 304	n/a	n/a	4	6
15	handle	AISI 304/rubber	1	n/a	n/a	n/a
15A	handle (rod)	AISI 304/rubber	n/a	1	1	1
16	stop pin	AISI 316	1	1	1	1
17	gasket	see chart below	2	2	2	2
18	handle nut	AISI 304	n/a	1	1	1
19	handle head	AISI 304	n/a	1	1	1

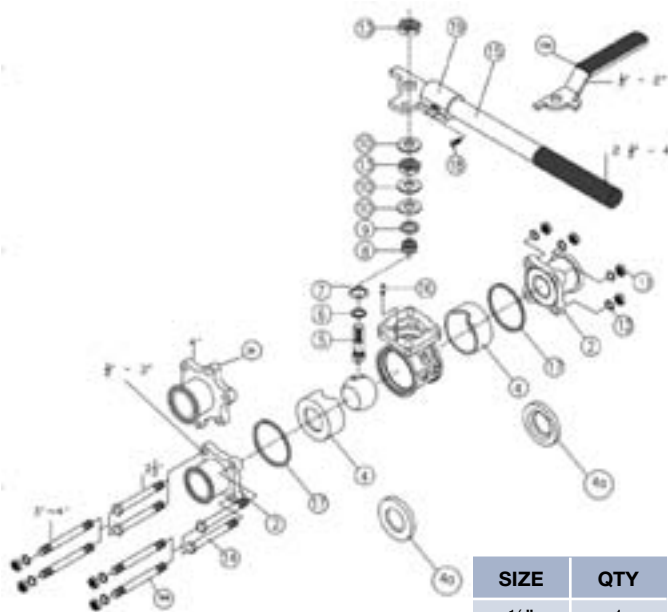

SIZE	QTY
1/2"	1
3/4"	2
1" - 2"	3

REPAIR KITS FOR BV2C

SIZE	VIRGIN PTFE	RTFE	25% CARBON TFE	50% STAINLESS PTFE	UMHW
1/2"	BV-2C-VK050	BV-2C-GK050	BV-2C-CK050	BV-2C-SK050	BV-2C-UK050
3/4"	BV-2C-VK075	BV-2C-GK075	BV-2C-CK075	BV-2C-SK075	BV-2C-UK075
1"	BV-2C-VK100	BV-2C-GK100	BV-2C-CK100	BV-2C-SK100	BV-2C-UK100
1 1/2"	BV-2C-VK150	BV-2C-GK150	BV-2C-CK150	BV-2C-SK150	BV-2C-UK150
2"	BV-2C-VK200	BV-2C-GK200	BV-2C-CK200	BV-2C-SK200	BV-2C-UK200
2 1/2"	BV-2C-VK250	BV-2C-GK250	BV-2C-CK250	BV-2C-SK250	BV-2C-UK250
3"	BV-2C-VK300	BV-2C-GK300	BV-2C-CK300	BV-2C-SK300	BV-2C-UK300
4"	BV-2C-VK400	BV-2C-GK400	BV-2C-CK400	BV-2C-SK400	BV-2C-UK400

Repair Kit contains:

- (2) body seals
- (2) O-rings
- (1) thrust washer
- (3) stem packings

Non-encapsulated version also available for actuation.

SEAT MATERIAL OPTIONS

CODE	DESCRIPTION
V	Virgin PTFE
G	RTFE
C	25% carbon PTFE
S	SS reinforced PTFE
U	UHMW

2-Way 3-piece Non-Encapsulated Ball Valve



This ball valve is designed as a three piece construction with swing out centre section for easy field repair and cleaning in place. Operating parts are stainless steel type CF8M (316) conforming to ASTM A351, solution annealed and passivated for corrosion resistance. Integral ISO 5211 mounting pad is part of the valve design making actuation easy without any custom brackets. The handle makes this suitable for lock-out / tag-out applications.

- ID is polished to 3A or better
- Blow-out-proof stem design
- Various Ends Available: Clamp, RJT, Buttweld, DIN, SMS & IDF
- Actuation available: double, air-to-spring, and electric
- Rated at 1,000 PSI WOG (water, oil and gas), most applications

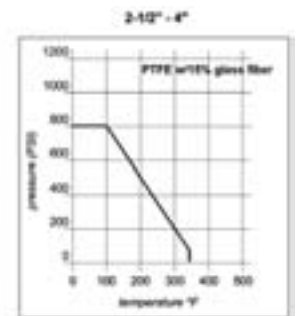
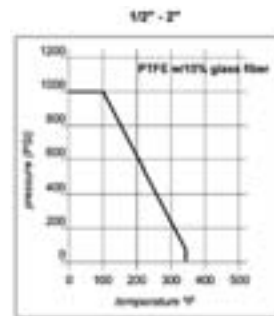
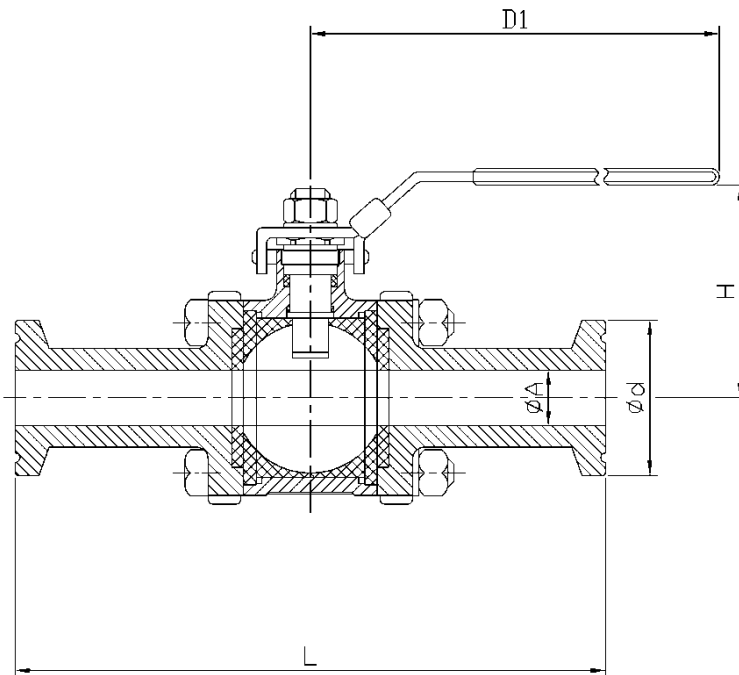

PART NO.	SIZE	DIMENSIONS (inches)					BREAK TORQUE (lbs)	WEIGHT (lbs)
		D1	H	L	ØA	ØD		
BV2GG-050CC-A	1/2"	4.1	2.3	4.6	0.37	1.0	55	1.4
BV2GG-075CC-A	3/4"	4.1	2.5	4.7	0.63	1.0	71	1.8
BV2GG-100CC-A	1"	5.0	2.8	4.9	0.87	2.0	101	2.6
BV2GG-150CC-A	1 1/2"	6.1	3.5	5.6	1.38	2.0	221	4.6
BV2GG-200CC-A	2"	7.6	3.9	6.4	1.87	2.5	345	8.5
BV2GG-250CC-A	2 1/2"	7.6	4.4	7.8	2.37	3.0	883	17.8
BV2GG-300CC-A	3"	10.9	4.9	9.0	2.87	3.6	830	28.2
BV2GG-400CC-A	4"	13.2	6.6	9.6	3.83	4.7	1323	41.4

Note: all dimensions are in inches. Dimensions are approximate. Engineering dimensions are available upon request.

Specifications are subject to change without notice.

3-Way Encapsulated Hygienic Ball Valve



The Dixon 3-way ball valve is designed with a balanced four seat construction. Live loaded stem packing provides a leak-proof design allowing time to schedule maintenance. Operating parts are stainless steel type CF8M (316) conforming to ASTM A351, solution annealed and passivated for corrosion resistance. It is fully encapsulated to eliminate cavities for bacteria to form. Multiple flow patterns allow for more versatility in your processing applications. Integral ISO 5211 mounting pad is part of the valve design making actuation easy. The handle makes this suitable for lock-out / tag-out applications.

- ID is polished to 3A or better (Ra 32 min 0.8 micron)
- Blow-out-proof stem design
- Various ends available: Clamp, Butt weld, RJT, DIN, SMS, and IDF
- Actuation available: double-acting, air-to-spring, electric
- Rated at 1,000 PSI WOG (water, oil and gas) most applications
- Live loaded stem packing
- T and L flow patterns (side entry only)

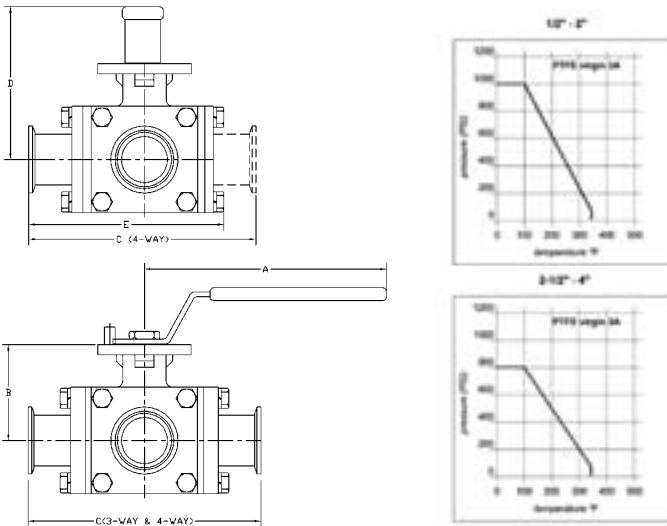

3-WAY 'L' PORT PART NUMBER	3-WAY 'T' PORT PART NUMBER	SIZE (inches)	DIMENSIONS (inches)					BREAK TORQUE (IN-LBS.)		WEIGHT (LBS.)
			A	B	C	D	E	'L' PORT	'T' PORT	
BV3S*LF050CC-A	BV3S*TF050CC-A	1/2"	4.7	1.8	4.6	3.2	3.9	62	50	3.6
BV3S*LF075CC-A	BV3S*TF075CC-A	3/4"	4.7	1.9	5.0	3.4	4.2	75	60	4.3
BV3S*LF100CC-A	BV3S*TF100CC-A	1"	5.2	2.3	6.0	3.8	5.0	100	80	6.8
BV3S*LF150CC-A	BV3S*TF150CC-A	1 1/2"	7.2	2.8	6.9	4.5	5.8	262	210	12.6
BV3S*LF200CC-A	BV3S*TF200CC-A	2"	7.2	3.2	7.5	5.0	6.7	535	425	21.6
BV3S*LF250CC-A	BV3S*TF250CC-A	2 1/2"	14.6	3.9	9.0	5.3	7.1	1250	1000	33.7
BV3S*LF300CC-A	BV3S*TF300CC-A	3"	15.7	4.9	10.2	6.4	8.5	1625	1300	56.4
BV3S*LR400CC-A	BV3S*TR400CC-A	4"	15.7	5.3	11.4	6.8	10.6	1875	1500	85.4

• (*) see seat material options chart on page 193.

• All dimensions are in inches. Dimensions are approximate. Engineering dimensions are available upon request. Specifications are subject to change without notice.

T PATTERN (TOP VIEW, 3 WAY, SIDE ENTRY)					
NUMBER	ROTATION	FLOW PLAN OPTIONS	NUMBER	ROTATION	FLOW PLAN OPTIONS
1	90°	1	5	180°	1
2	90°	2	6	180°	2
3	90°	3	7	180°	3
4	90°	4	8	180°	4

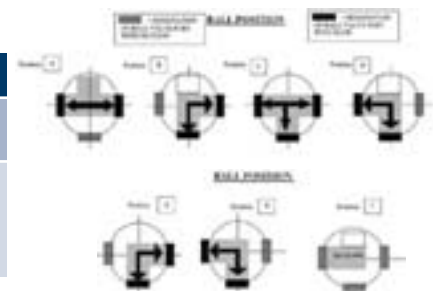

Multi-port 3-way Hygienic Stainless Steel Ball Valve

Materials List for BV3S/BV4S

ITEM	DESCRIPTION	MATERIAL	QUANTITY			
			3-WAY		4-WAY	
			1/2"-2"	2 1/2"-4"	1/2"-2"	2 1/2"-4"
1	body	ASTM A351-CF8M	1	1	1	1
2	end (large)	ASTM A351-CF8M	3	1	4	2
2A	end (small)	ASTM A351-CF8M	n/a	2	n/a	2
3	ball	ASTM A351-CF8M	1	1	1	1
4	seat 1	see chart below	2	2	2	2
5	gasket	see chart below	2	2	2	2
6	thrust washer	see chart below	1	1	1	1
7	O-ring	RTF	1	1	1	1
8	stem packing	see chart below	*	3	*	3
9	ring	AISI 316	1	1	1	1
10	spring washer	AISI 301	2	2	2	2
11	stop pin	AISI 316	1	1	1	1
12	nut	AISI 304	1	1	1	1
13	stem	AISI 316	1	1	1	1
14	handle	AISI 304	n/a	1	n/a	1
14A	handle w/cover	AISI 304/plastic	1	n/a	1	n/a
15	lock washer	AISI 304	16	16	16	16
16	bolt	AISI 304	16	16	16	16
17	stem packing nut	AISI 304	1	1	1	1
18	cover plate	ASTM A351-CF8M	1	1	n/a	n/a
19	seat 2	see chart below	2	2	2	2
20	plug	see chart below	1	1	n/a	n/a
21	handle cover	plastic	n/a	1	n/a	1
22	lock washer	AISI 304	n/a	1	n/a	1
23	handle bolt	AISI 304	n/a	1	n/a	1

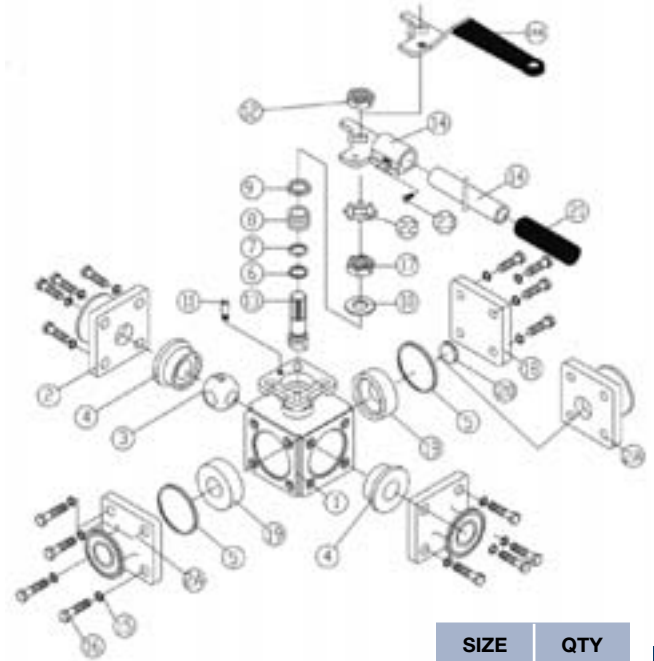

SIZE	QTY
1/2"	1
3/4"	2
1" - 2"	3



REPAIR KITS FOR BV3S					
SIZE	VIRGIN PTFE	RTFE	25% CARBON TFE	50% STAINLESS PTFE	UMHW
1/2"	BV-3SVFRK050	BV-3SGRK050	BV-3SCRK050	BV-3SSRK050	BV-3SURK050
3/4"	BV-3SVFRK075	BV-3SGRK075	BV-3SCRK075	BV-3SSRK075	BV-3SURK075
1"	BV-3SVFRK100	BV-3SGRK100	BV-3SCRK100	BV-3SSRK100	BV-3SURK100
1 1/2"	BV-3SVFRK150	BV-3SGRK150	BV-3SCRK150	BV-3SSRK150	BV-3SURK150
2"	BV-3SVFRK200	BV-3SGRK200	BV-3SCRK200	BV-3SSRK200	BV-3SURK200
2 1/2"	BV-3SVFRK250	BV-3SGRK250	BV-3SCRK250	BV-3SSRK250	BV-3SURK250
3"	BV-3SVFRK300	BV-3SGRK300	BV-3SCRK300	BV-3SSRK300	BV-3SURK300
4"	BV-3SVFRK400	BV-3SGRK400	BV-3SCRK400	BV-3SSRK400	BV-3SURK400

Repair Kit contains:

- (2) body seals
- (2) O-rings
- (1) thrust washer
- (3) stem packings

Non-encapsulated version also available for actuation.

SEAT MATERIAL OPTIONS	
CODE	DESCRIPTION
V	Virgin PTFE
G	RTFE
C	25% carbon PTFE
S	SS reinforced PTFE
U	UHMW

4 way available. Contact Dixon for more information.



Multi-port 4-way Hygienic Stainless Steel Ball Valve



SIZE	L' PORT PART NUMBER	'T' PORT PART NUMBER
1/2"	BV4S*LF050CC-A	BV4S*TF050CC-A
3/4"	BV4S*LF075CC-A	BV4S*TF075CC-A
1"	BV4S*LF100CC-A	BV4S*TF100CC-A
1 1/2"	BV4S*LF150CC-A	BV4S*TF150CC-A
2"	BV4S*LF200CC-A	BV4S*TF200CC-A
2 1/2"	BV4S*LF250CC-A	BV4S*TF250CC-A
3"	BV4S*LF300CC-A	BV4S*TF300CC-A
4"	BV4S*LR400CC-A	BV4S*TR400CC-A

REPAIR KITS FOR BV4S

SIZE	VIRGIN PTFE	RTFE	25% CARBON TFE	50% STAINLESS PTFE	UMHW
1/2"	BV-4SVRK050	BV-4SGRK050	BV-4SCRK050	BV-4SSRK050	BV-4SURK050
3/4"	BV-4SVRK075	BV-4SGRK075	BV-4SCRK075	BV-4SSRK075	BV-4SURK075
1"	BV-4SVRK100	BV-4SGRK100	BV-4SCRK100	BV-4SSRK100	BV-4SURK100
1 1/2"	BV-4SVRK150	BV-4SGRK150	BV-4SCRK150	BV-4SSRK150	BV-4SURK150
2"	BV-4SVRK200	BV-4SGRK200	BV-4SCRK200	BV-4SSRK200	BV-4SURK200
2 1/2"	BV-4SVRK250	BV-4SGRK250	BV-4SCRK250	BV-4SSRK250	BV-4SURK250
3"	BV-4SVRK300	BV-4SGRK300	BV-4SCRK300	BV-4SSRK300	BV-4SURK300
4"	BV-4SVRK400	BV-4SGRK400	BV-4SCRK400	BV-4SSRK400	BV-4SURK400

Repair Kit contains:

- (2) body seals
- (2) O-rings
- (1) thrust washer
- (3) stem packings

G

4-Way Ball Valve Flow Options

'T' PATTERN, SIDE ENTRY

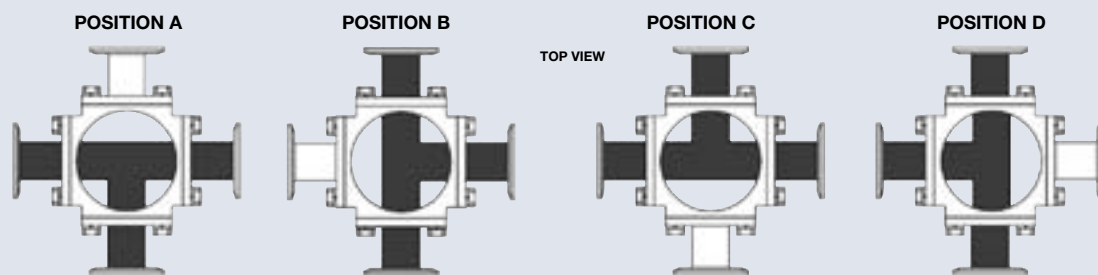

'L' PATTERN, SIDE ENTRY

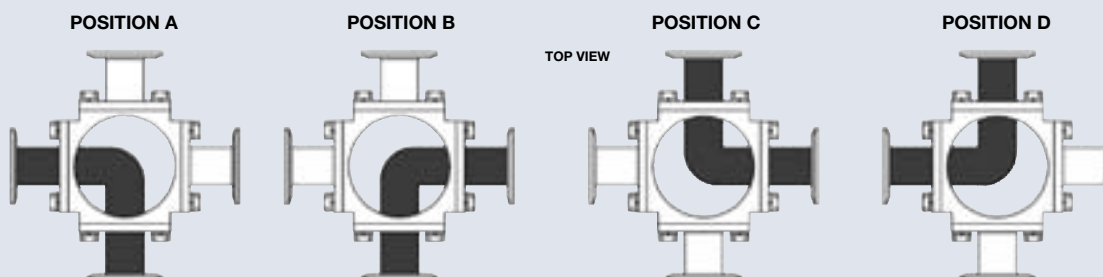

Ball Valve Automation

Manual Ball Valves with Limit Switch

Dixon Hygienic offers remote indication on manual valve.

This allows an operator to see valve position from a central panel in the plant, saving labour costs.

Features and Benefits

- Signal back equipment can be provided for information on open / close positions, intermediate and proportional feedback
- Position detection can be determined using mechanical switches, proximity switches, or 4-20 mA signal transmission in NEMA 4 or NEMA 7 enclosures.



Bradford™ manual ball valve pictured with remote indication. **BV2CV-150CC-LB** Remote indication is also available on butterfly valves.

G

Multi-port Hygienic Ball Valves with Actuator



Bradford™ automated 1½" 3-way 'L'-port encapsulated hygienic ball valve with double acting actuator and NEMA 4 limit switch with two SPDT mechanical switches and NEMA 4 115 VAC solenoid pictured. **BV3SVLF150CBXC**.



Bradford™ automated ½" 3-way 'L'-port encapsulated hygienic ball valve with double acting actuator and NEMA 4 limit switch with two SPDT mechanical switches and NEMA 4 115 VAC solenoid pictured. **BV3SVLF050CBXC**.

Ball Valve Automation (continued)

3 piece Stainless Steel Hygienic Ball Valves

Dixon Hygienic offers various configurations of automated hygienic 2-way ball valves. Call for price and delivery of different options.



Bradford™ automated 1/2" encapsulated 2-way ball valve butt-weld ends spring return actuator and NEMA 7 (explosion proof) SPDT limit switch with two proximity switches and NEMA 7 NAMUR mount 24VDC voltage solenoid valve pictured. **BV2CV-050BB-FPC.**



Bradford™ automated 3" encapsulated ball valve with direct mount double acting, (normally open), actuator and NEMA 7 (explosion proof with 2 mechanical switches) SPDT limit switch pictured. **BV2CV-300CC-QAC.**



Bradford™ automated 2 1/2" 2-way encapsulated ball valve with spring return fail close actuator and NEMA 4/4X limit switch with two SPDT mechanical switches pictured. **BV2CV-250CC-BFC.**

Butterfly Valves

- Size Range:** 1" - 8" O.D. (25 - 200mm)
- Materials:** (316) CF8M
- Type of ends available:** Clamp, Buttweld, RJT, DIN, SMS, IDF
- Type of seats available:** EPDM, Viton®, Silicone

Contact Dixon for price and availability.



Dixon Hygienic offers a wide selection of Bradford™ stainless steel butterfly valves for use in hygienic process systems. These valves are simple, rugged and above all, dependable. Bradford™ butterfly valves can be used either as a shutoff valve (on/off service) or as a throttling valve (for flow control).

Pneumatic or electric actuators are available for automated control.

All Bradford™ butterfly valves are assembled without silicone lubricant.



B5101 Series Butterfly Valve

Application

Get control with the Bradford™ B5101 series stainless steel butterfly valves. The slim design, superior craftsmanship, choice materials, top quality strength and surface finished make the B5101 the preference of many industries with hygienic requirements. Various elastomers, end types and accessories make this a highly versatile valve.

Typical uses would include isolation of equipment, fill/drain systems, bypass systems and other similar applications.

Working Principle

The B5101 is actuated manually with various handle options or remotely by a pneumatic or electric actuator.

A variety of handle options for manual flow regulation are available. The valve is fully open when the handle is parallel to the pipeline.



G

Pneumatic actuators are available in three styles:

- air to open - spring to close (ATO/STC)
- air to close - spring to open (ATC/STO)
- double acting (ATO/ATC)

Features and Benefits

- Low resistance to flow
- Bi-directional
- Gentle to media
- Suitable for low and medium viscosity fluids
- Field serviceable (no special tools required)
- Self-draining
- Various manual or automatic operators available
- Special handle available for accurate, manual flow balancing capabilities
- Polyacetal bushings for the valve disc reduce friction and increase cycle life
- Optional wing nut kit is available for effortless valve assembly and disassembly
- 100% tested/100% inspected
- All wetted surfaces are hygienic finished to < 32Ra
- Seat materials available include: silicone, EPDM, Viton®, (6" EPDM and silicone, 8" EPDM only)
- Sizes from 1" - 8"

B5101 Series Butterfly Valve



B51 SERIES BUTTERFLY VALVE WITH PULL HANDLE

SIZE	PART NUMBER WITH SILICONE SEATS	PART NUMBER WITH VITON® SEATS	PART NUMBER WITH EPDM SEATS
1"	B5101S100XX-A	B5101V100XX-A	B5101E100XX-A
1½"	B5101S150XX-A	B5101V150XX-A	B5101E150XX-A
2"	B5101S200XX-A	B5101V200XX-A	B5101E200XX-A
2½"	B5101S250XX-A	B5101V250XX-A	B5101E250XX-A
3"	B5101S300XX-A	B5101V300XX-A	B5101E300XX-A
4"	B5101S400XX-A	B5101V400XX-A	B5101E400XX-A
6"	B5101S600XX-A	--	B5101E600XX-A
8"	-----	--	B5101E800XX-A

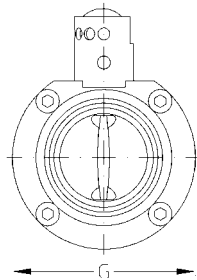
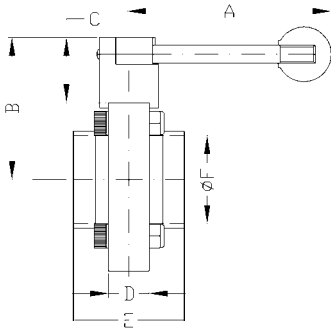

SIZE	DIMENSIONS (mm)						
	A	B	C	D	E	F	G
1"	111.76	71.12	35.56	22.86	48.26	22.86	78.74
1½"	111.76	71.12	35.56	22.86	48.26	35.56	78.74
2"	111.76	78.74	35.56	22.86	50.80	48.26	99.06
2½"	111.76	88.90	35.56	22.86	53.34	60.96	116.84
3"	157.48	96.52	33.02	30.48	63.50	73.66	132.08
4"	157.48	114.30	33.02	30.48	78.74	96.52	170.18
6"	292.10	139.70	33.02	30.48	139.70	147.32	215.90
8"	457.20	175.26	40.64	30.48	124.46	198.12	284.48

Note: All dimensions are for Butt Weld End option. Dimensions are approximate.

Engineering dimensions are available upon request.

Specifications are subject to change without notice.

G

RJT, DIN, SMS, IDF CLAMP ENDS AVAILABLE.

B51 SERIES BUTTERFLY VALVE WITH TRIGGER HANDLE



SIZE	PART NUMBER WITH SILICONE SEATS	PART NUMBER WITH VITON® SEATS	PART NUMBER WITH EPDM SEATS
1"	B5101S100XX-C	B5101V100XX-C	B5101E100XX-C
1½"	B5101S150XX-C	B5101V150XX-C	B5101E150XX-C
2"	B5101S200XX-C	B5101V200XX-C	B5101E200XX-C
2½"	B5101S250XX-C	B5101V250XX-C	B5101E250XX-C
3"	B5101S300XX-C	B5101V300XX-C	B5101E300XX-C
4"	B5101S400XX-C	B5101V400XX-C	B5101E400XX-C
6"	B5101S600XX-C	--	B5101E600XX-C
8"	-----	--	B5101E800XX-C

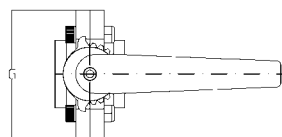
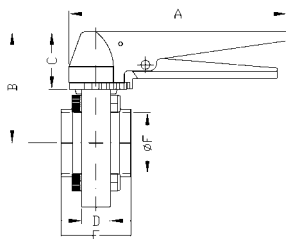

SIZE	DIMENSIONS (mm)						
	A	B	C	D	E	F	G
1"	167.64	76.20	43.18	22.86	48.26	22.86	78.74
1½"	167.64	76.20	43.18	22.86	48.26	35.56	78.74
2"	167.64	88.90	43.18	22.86	50.80	48.26	99.06
2½"	167.64	93.98	43.18	22.86	53.34	60.96	116.84
3"	167.64	99.06	43.18	30.48	63.50	73.66	132.08
4"	167.64	121.92	43.18	30.48	78.74	96.52	170.18

Note: All dimensions are for Butt Weld End option. Dimensions are approximate.

Engineering dimensions are available upon request.

Specifications are subject to change without notice.

RJT, DIN, SMS, IDF CLAMP ENDS AVAILABLE.

G

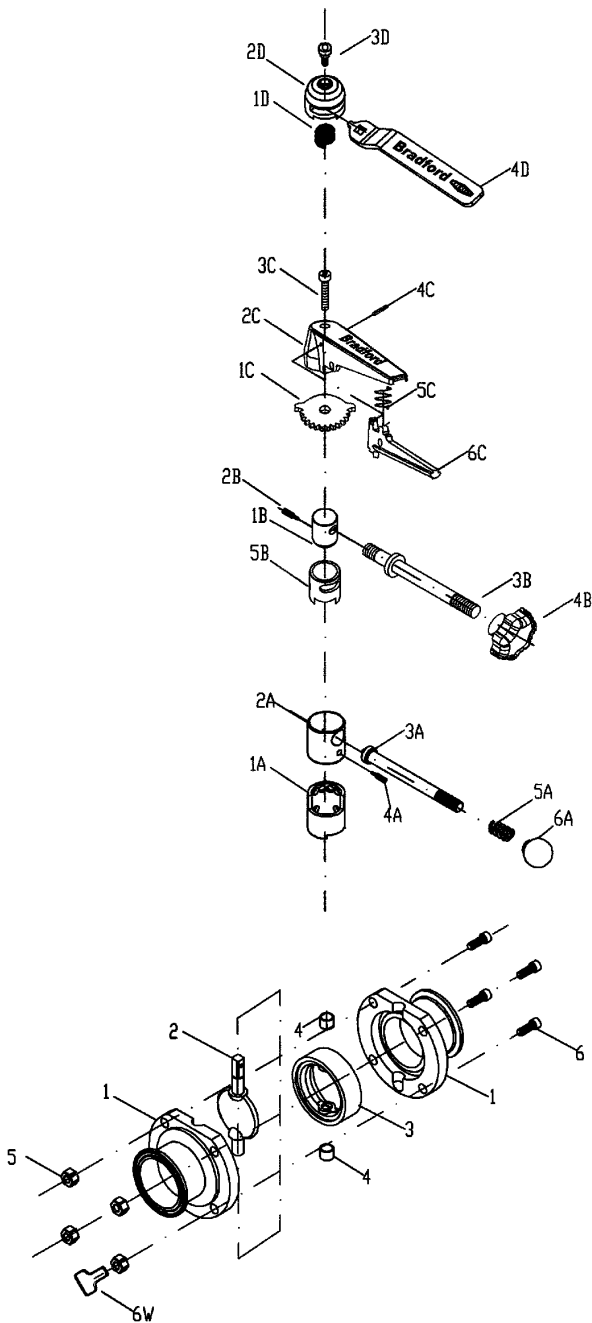

MATERIALS LIST			
ITEM #	DESCRIPTION	MATERIAL	QTY
PUSH HANDLE			
1D	spring	304	1
2D	hub	CF8	1
3D	handle	CF8	1
4D	hex socket bolt	304	1
TRIGGER HANDLE			
1C	sprocket	CF8	1
2C	handle	CF8	1
3C	hex socket bolt	304	1
4C	pin	304	1
5C	spring	304	1
6C	trigger	CF8	1
INFINITE HANDLE			
1B	hub	CF8	1
2B	hex socket screw	304	1
3B	handle shaft	304	1
4B	knob	polymer	1
5B	hub housing	CF8	1
PULL HANDLE			
1A	hub housing	CF8	1
2A	hub	CF8	1
3A	handle shaft	304	1
4A	hex socket screw	304	1
5A	spring	304	1
6A	knob	polymer	1
VALVE			
1	body half	CF8M	1
2	disc	CF8M	1
3	seat	silicone EPDM Viton®	1
4	bushing	polyacetal	2
5	hex nut	304	4 *
6	bolt	304	4 *
6W	wing nut kit (optional)	304	4 *

* 6" valve has a quantity of 8 each
4" and 8" valves have a quantity of 6 each

Repair Kit contains:

- (1) silicone, EPDM, or Viton® seal
- (2) bushings

B51 SERIES BUTTERFLY VALVE WITH TRIGGER HANDLE			
SIZE	(RED) SILICONE PART NO.	(BLACK) EPDM PART NO.	(BROWN) VITON® PART NO.
1"	B5101-RKS100	B5101-RKE100	B5101-RKV100
1½"	B5101-RKS150	B5101-RKE150	B5101-RKV150
2"	B5101-RKS200	B5101-RKE200	B5101-RKV200
2½"	B5101-RKS250	B5101-RKE250	B5101-RKV250
3"	B5101-RKS300	B5101-RKE300	B5101-RKV300
4"	B5101-RKS400	B5101-RKE400	B5101-RKS400
6"	B5101-RKS600	B5101-RKE600	---
8"	---	B5101-RKE800	---

Butterfly Valve Automation - 5101 Series

Technical Data, Specifications and Dimensions

SIZE	DIMENSION A (in)
1"	68.58
1½"	68.58
2"	78.74
2½"	88.9
3"	93.98
4"	114.3

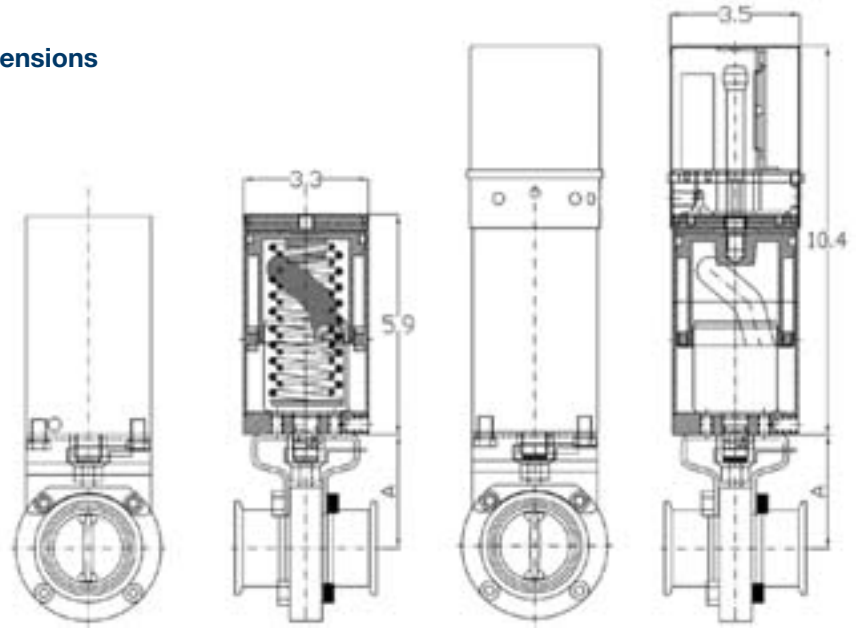

Note: all dimensions are in inches. Dimensions are approximate. Engineering dimensions are available upon request.

Specifications are subject to change without notice.

G

BUTTERFLY VALVE WITH EPDM SEATS AND A VERTICAL SPRING RETURN NORMALLY OPEN PNEUMATIC CANISTER STYLE ACTUATOR

PART NUMBER	SIZE
B5101E100CC-F	1"
B5101E150CC-F	1½"
B5101E200CC-F	2"
B5101E250CC-F	2½"
B5101E300CC-F	3"
B5101E400CC-F	4"



BUTTERFLY VALVE WITH EPDM SEATS AND A VERTICAL SPRING RETURN NORMALLY CLOSED PNEUMATIC CANISTER STYLE ACTUATOR

PART NUMBER	SIZE
B5101E100CC-G	1"
B5101E150CC-G	1½"
B5101E200CC-G	2"
B5101E250CC-G	2½"
B5101E300CC-G	3"
B5101E400CC-G	4"

BUTTERFLY VALVE WITH EPDM SEATS AND A VERTICAL DOUBLE ACTING PNEUMATIC CANISTER STYLE ACTUATOR

PART NUMBER	SIZE
B5101E100CC-H	1"
B5101E150CC-H	1½"
B5101E200CC-H	2"
B5101E250CC-H	2½"
B5101E300CC-H	3"
B5101E400CC-H	4"

SILICONE AND VITON® SEATS ARE ALSO AVAILABLE.

Manual Butterfly Valves with Limit Switch

Dixon Hygienic offers remote indication on manual valves. Make sure valves are open or closed from a remote location.

Features and Benefits

- Signal back equipment can be provided for information on open / close positions, intermediate and proportional feedback
- Position detection can be determined using mechanical switches, proximity switches, or 4-20 mA signal transmission in NEMA 4 or NEMA 7 enclosures



Bradford™ manual butterfly valve with remote indication.

B5101S200CC-LJ remote indication is also available on ball valves.



Bradford™ automated butterfly valve with vertical canister air-to-open spring-to-close actuator and proximity sensors. **B5101S200CC-MI**



Bradford™ automated butterfly valve with vertical canister air-to-open spring-to-close actuator and control top, with 24VDC solenoid. **B5101S200CC-ZB**

DIXON HYGIENIC OFFERS VARIOUS CONFIGURATIONS OF AUTOMATED BUTTERFLY VALVES. CALL FOR PRICE AND DELIVERY.

Valve Automation Introduction



Bradford™ stainless steel pneumatic vertical canister actuators are designed for use on butterfly valve sizes up to 4". They are available with the Bradford™ control top, in addition to other accessories.

Bradford™ stainless steel pneumatic horizontal actuators are designed for use on ball and butterfly valves. A special double acting design is for use on the B5102 series butterfly valve. Rack and pinion actuators can be used on either ball or butterfly valves.

Bradford™ aluminum pneumatic rack and pinion horizontal actuators are designed for use on all ball and butterfly valves.

Bradford™ electric actuators are designed for use on all ball and butterfly valves.

Accessories for valve automation are not limited. Dixon Hygienic can offer almost everything necessary to automate any Bradford™ valve, or any other manufacturers valve.

Dixon Hygienic products are rugged and dependable. Most actuated products can ship within 24 hours of the order being placed.

Inductive Proximity Sensors

PART NO. PS-AM1-AP-2A SPECIFICATIONS	
Sensing Range	0-4mm
Housing	Unshielded - nickel plated brass housing
Output State	Normally Open
Logic	PNP
Connection	2m axial cable
Wiring	see diagram 1
Dimensions	see diagram 2
Size	M12
Power	10-30 VDC
Rating	IP 67 w/ complete overload protection
Differential Travel	2 to 10%
Repeat Accuracy	< 2%
Ripple	< 10%
No Load Supply Current	< 20mA
Load Current	< 200mA
Leakage Current	< 10µA
Voltage Drop	1.2 Volts maximum
Switching Frequency	2KHz
(tv) Time Delay before availability	100ms
Input Voltage Transient Protection	up to 30 VDC
Output Power Short-Circuit Protection	yes (switch auto resets after overload is removed)
Temperature Range	-25° to 70° C
Temperature DRIFT	10% Sr
Protection Degree (DIN 40050)	IEC IP67
LED Indicators	yellow (N.O. output energized)
Sensing Face Material	PBT
Tightening Torque	88 in-lb
Weight	70g
Material Correction Factors	SS (x0.85) - steel type FE 360(x1.00)

Other voltages, housings, and options available.

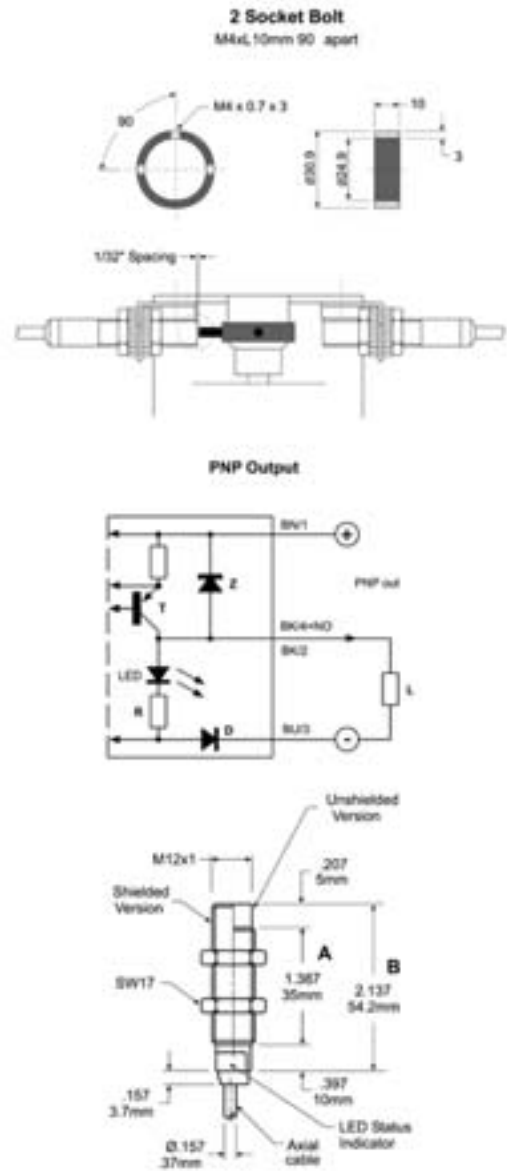

Bracket Mounted Micro-Switches

These bracket mounted mechanical micro switches are mounted directly to the bracket between the actuator and the valve. This is the most economical means of sending a signal for open and close indication.

- Input voltage: 24 to 48VDC; 110 to 250 VAC
- Maximum current: 5 amps
- Life cycles mechanical: 5,000,000
- Temperature range: (40°F to 175°F) 4.5°C to 79.5°C

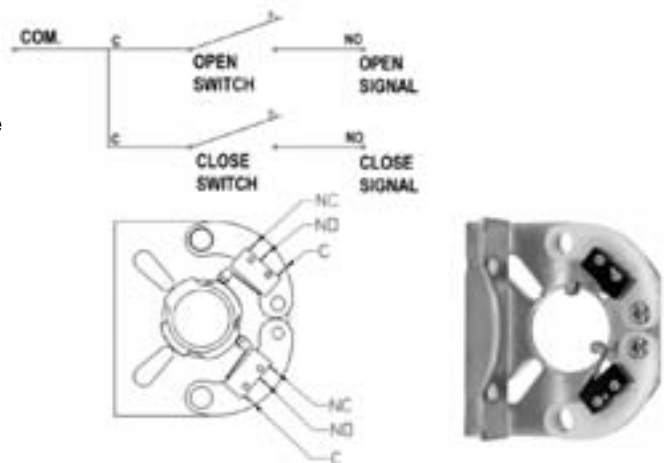

Limit Switches for Pneumatic Actuators

Features

- Compact, cost-efficient, low profile limit switches for both local and remote indication of valve and/or actuator position
- Wide variety of switch options are available
- Visual position indicator
- Quick-Set cam
- Multipoint terminal strip
- Dual wire potting
- Captive cover bolts
- UL and CENEFLEC approved
- NEMA 4, 4X, 7 and 9
- Standard NAMUR mounting

Technical Specifications

- Enclosure: weatherproof, 1P67
- Temperature range: -4°F (20°C) to 185°F (85°C)
- Cable entry: 2 x 1/2" NPT
- Terminal strip: 8 points
- Position indicator: 0 - 90: open - yellow, close - red
- Switch type: 2 SPDT mechanical switches
- Painting: black polyester powder coating
- Bracket: stainless steel

XLS-B4A0120P (NEMA 4/4X ENCLOSURE)

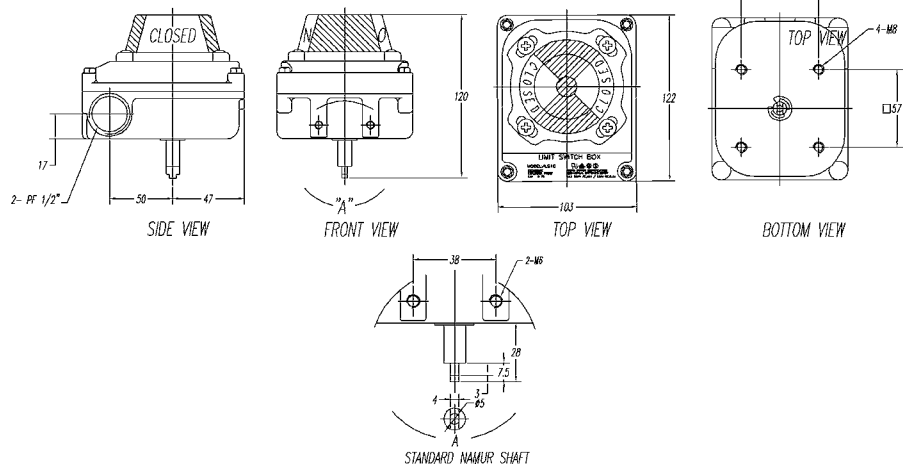

XLS-B7A0120P (NEMA 7 ENCLOSURE)

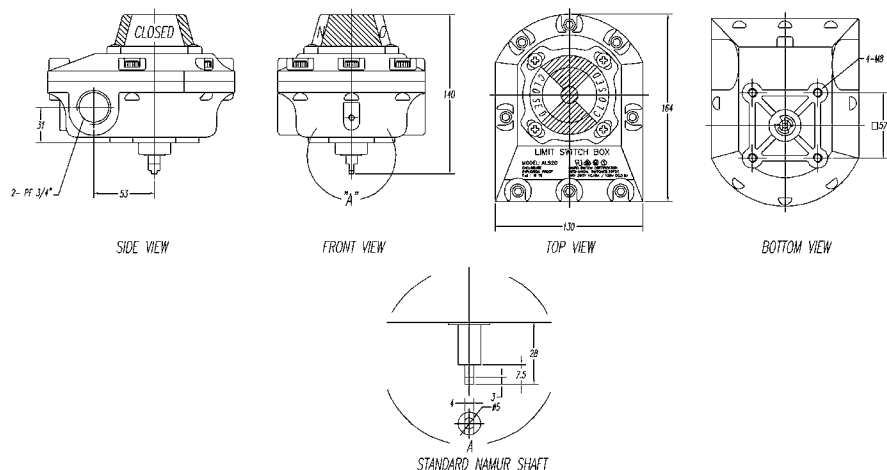

NAMUR Mount Solenoid Valves



Features

- Exclusive 'pop-up' indicator provides a quick check for valve pressurisation
- Easy to use override
- Single, dual coils or 3 position configurations are available
- NEMA 4 or 7 versions are available
- Lighted DIN connectors are available
- Intrinsically safe coils are available

Material Specifications

- Body: epoxy coated die cast aluminum optional body material: stainless steel
- Spool: electroless-nickel plated aluminum
- Piston: aluminum
- Spring: stainless steel
- Seal: Buna N (standard) optional seal material: EPDM
- Screws: stainless steel
- other components: technopolymer

Technical Specifications

- DC Coil Voltage: 12v, 24v
- AC Coil Voltage (60Hz): 24v, 120v, 220v
- Standard Protection Class: NEMA 4 (DIN connector, as shown)
- Electrical Connection: 9mm DIN connector (DIN 43650)
- Coil Insulation: Class F
- Supply Air and Environment Temperature Limits: -20° to 70°C
- BunaN seal temperature range: -20° to 70°C
- EPDM seal temperature range: -10° to 120°

Note: Temperature ranges indicate air temperatures for seal material.

XSO-4S4-0A NEMA 4, FOUR WAY SINGLE COIL, 115 VAC

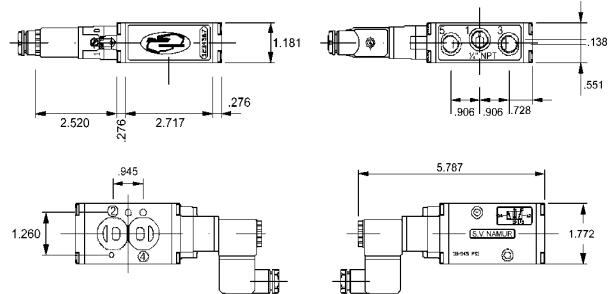

XSO-4S7-0A NEMA 7, FOUR WAY SINGLE COIL, 115 VAC

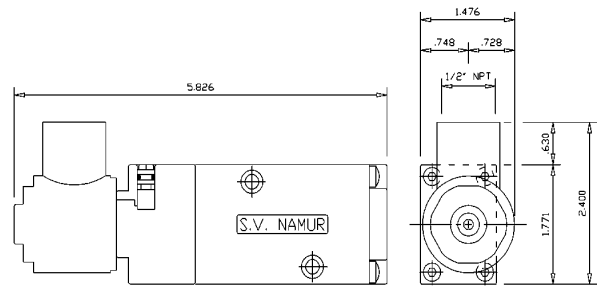

XSO-4D4D-0A NEMA 4, FOUR WAY DUAL COIL, 115 VAC

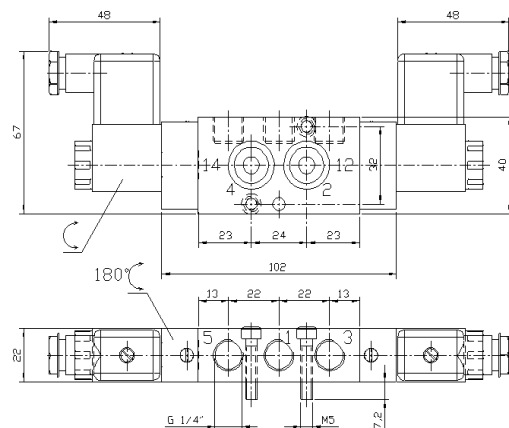

Positioners

XPO-P4F (Pneumatic Positioner)

Features

- Cam characterized and force balanced
- Cast aluminum NEMA 4X housing with electrostatically applied polyester coating
- Operates on a standard 3-15 Volt PSI signal (12 PSI span, optional 24 PSI)
- Pressure gauge blocks built into the unit
- Large indicator has scaling to operate in both direct and reverse directions
- Feedback units available - call factory for details

Technical Specifications

- Input range: 3-15 PSI
- Supply pressure: <145 PSI
- Linearity error: <0.7 f.s.
- Hysteresis: <0.4 f.s.
- Repeatability: <0.3 f.s.
- Pressure gain: 750:1 P
- Air delivery:

	SCFM
@ 29 PSI (200 kPa)	9.5
@ 87 PSI (600 KPa)	28.3
@ 145 PSI	47.1
- Air consumption:

	SCFM
@ 29 PSI (200 kPa)	0.18
@ 87 PSI (600 KPa)	0.53
@ 145 PSI	0.88
- Temperature range: -40°F (-40°C) to 185°F (85°C)
- Air connections: 1/4" NPT
- Gauge port: 1/8" NPT
- Ingress and corrosion protection: NEMA 4X and IP 66
- Coating: Powder polyester (nickel - optional)
- Weight: 3.5 lbs.



XPO-E4F (Electro-Pneumatic Positioner)

Features

- Cam characterized and force balanced
- Cast aluminum NEMA 4X housing with electrostatically applied polyester coating
- Operates on a 4-20 mA signal
- Pressure gauge blocks built into the unit
- Large indicator has scaling to operate in both direct and reverse directions
- Feedback units available - call factory for details

Technical Specifications

- Input range: 4-20 (R1<170 ohms)
- Supply pressure: 22-145 PSI
- Linearity error: <1.0 f.s.
- Hysteresis: <0.5 f.s.
- Repeatability: <0.3 f.s.
- Pressure gain: 750:1 P out / P in
- Air delivery: SCFM

@ 29 PSI (200 kPa)	9.5
@ 87 PSI (600 KPa)	28.3
@ 145 PSI	47.1
- Air consumption: SCFM

@ 29 PSI (200 kPa)	0.18
@ 87 PSI (600 KPa)	0.53
@ 145 PSI	0.88
- Temperature range: -40°F (-40°C) to 185°F (85°C)
- Air connections: 1/4" NPT
- Gauge port: 1/8" NPT
- Ingress and corrosion protection: NEMA 4X and IP 66
- Coating: Powder polyester (nickel - optional)
- Weight: 3.8 lbs.

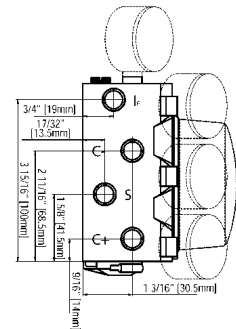
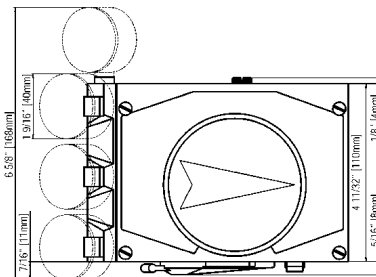
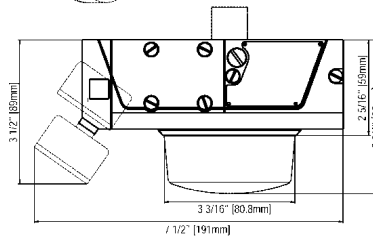
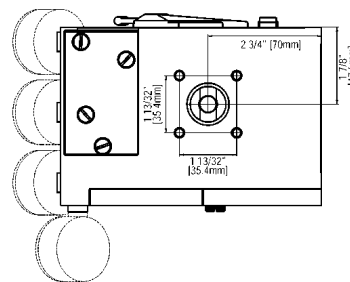

G

Vertical Stainless Steel Canister

without Control Top

- Excellent protection and corrosion resistance
- Tested to 1 million cycles
- 100% fully tested prior to shipment
- Backed by one year manufacturer's warranty
- Designed for butterfly valves sizes 1" - 4"
- Available in:
 - Air to open / air to close (ATO/ATC)
 - Air to open / spring to close (ATO/STC)
 - Spring to open / air to close (STO/ATC)

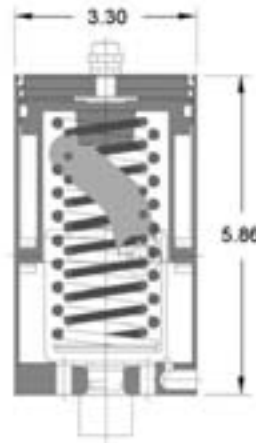

Note: All dimensions are in inches. Dimensions are approximate. Engineering dimensions are available upon request.

Specifications are subject to change without notice.

SIZES	DESCRIPTION	PART NUMBER	
		110vAC	24vDC
1" - 4"	Double Acting	VC-NR-100-DA	VC-NR-100-DA-ZI
1" - 4"	Spring Return	VC-NR-100-SR	VC-NR-100-SR-ZG

with Control Top

- Excellent protection and corrosion resistance
- Tested to 1 million cycles
- 100% fully tested
- Backed by one year manufacturer's warranty
- Designed for butterfly valves sizes 1" - 4"
- Includes control top with solenoid and micro switches for flawless control
- Available in:
 - Air to open / air to close (ATO/ATC)
 - Air to open / spring to close (ATO/STC)
 - Spring to open / air to close (STO/ATC)
 - 24 volt DC solenoid
 - 110 volt AC solenoid

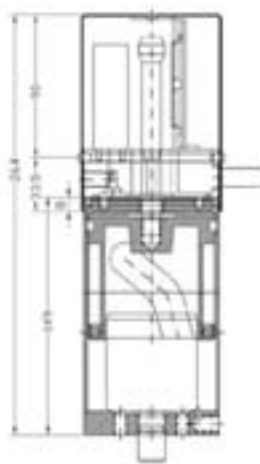

Note: All dimensions are in inches. Dimensions are approximate. Engineering dimensions are available upon request.

Specifications are subject to change without notice.

SIZES	DESCRIPTION	PART NUMBER	
		110vAC	24vDC
1" - 4"	Double Acting	VC-NR-100-DA-ZJ	VC-NR-100-DA-ZI
1" - 4"	Spring Return	VC-NR-100-SR-ZH	VC-NR-100-SR-ZG

Note: Each Bradford™ pneumatically actuated butterfly valve is shipped fully assembled, including pneumatic actuator and mounting bracket assembly. When ordering spring return actuators, please indicate if the valves need to be normally open or normally closed.

Vertical Stainless Steel Canister and control top

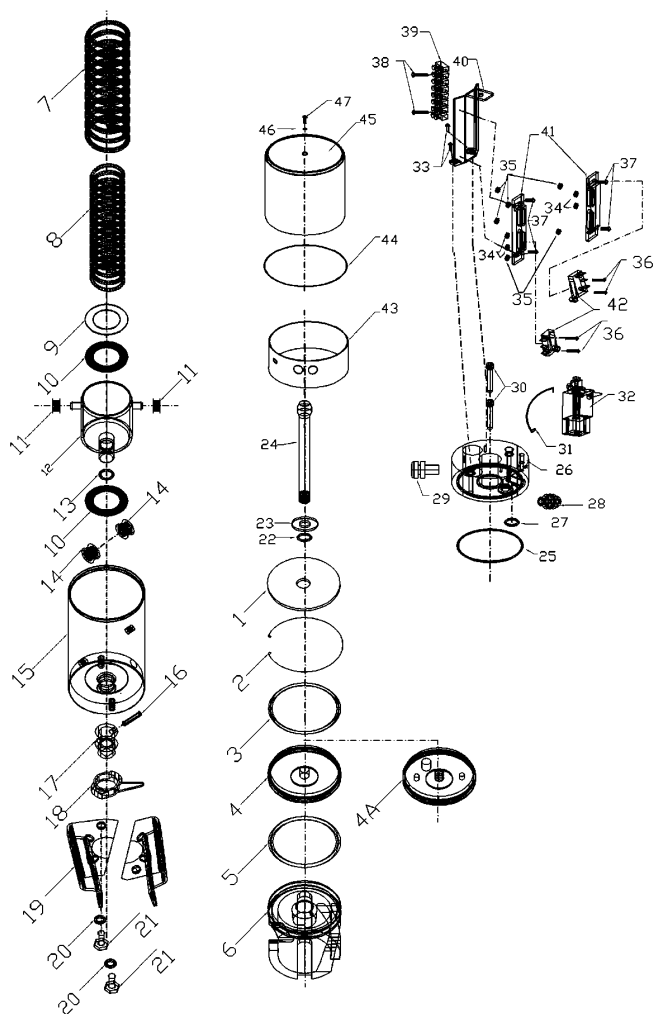

MATERIALS LIST

ITEM	DESCRIPTION	MATERIAL	QUANTITY			
			w/o Control Top	SR	DA	SR
1	top cap	304 stainless	1	1	n/a	n/a
2	retaining ring	304 stainless	1	1	1	1
3	O-ring	EPDM	1	1	1	1
4	end cap	304 stainless	1	1	n/a	n/a
4A	manifold cap	304 stainless	n/a	n/a	1	1
5	O-ring	EPDM	1	1	1	1
6	piston	aluminum	1	1	1	1
7	outer spring	302 stainless	1	n/a	1	n/a
8	inner spring	302 stainless	1	n/a	1	n/a
9	thrust drive	304 stainless	1	n/a	1	n/a
10	thrust bearing	304 stainless	2	1	2	1
11	needle bearing	304 stainless	2	2	2	2
12	drive assembly	304 stainless	1	1	1	1
13	O-ring	EPDM	1	1	1	1
14	needle bearing	304 stainless	2	2	2	2
15	body	304 stainless	1	1	1	1
16	split pin	304 stainless	1	1	1	1
17	coupler	304 stainless	1	1	1	1
18	indicator	plastic	1	1	1	1
19	bracket spring	304 stainless	2	2	2	2
20	washer	304 stainless	2	2	2	2
21	bracket bolt	304 stainless	2	2	2	2
22	O-ring	EPDM	n/a	n/a	1	1
23	washer	304 stainless	n/a	n/a	1	1
24	detection shaft	304 stainless	n/a	n/a	1	1
25	O-ring	EPDM	n/a	n/a	1	1
26	manifold	POM	n/a	n/a	1	1
27	O-ring	EPDM	n/a	n/a	1	1
28	air fitting	nickel plated brass	1	2	1	4
29	conduit entry	plastic	n/a	n/a	1	1
30	bolt	304 stainless	n/a	n/a	2	2
31	pneumatic tube	polyethylene	n/a	n/a	1	4
32	solenoid valve	anodized AL	n/a	n/a	1	2
33	bolt	304 stainless	n/a	n/a	2	2
34	nut	304 stainless	n/a	n/a	4	4
35	nut	304 stainless	n/a	n/a	6	6
36	bolt	304 stainless	n/a	n/a	4	4
37	bolt	304 stainless	n/a	n/a	4	4
38	bolt	304 stainless	n/a	n/a	2	2
39	terminal strip	plastic	n/a	n/a	1	1
40	switch rack	304 stainless	n/a	n/a	1	1
41	switch plate	POM	n/a	n/a	2	2
42	mech. micro switch	silver contact	n/a	n/a	2	2
43	manifold sleeve	304 stainless	n/a	n/a	1	1
44	cover seal	PTFE	n/a	n/a	1	1
45	cover	304 stainless	n/a	n/a	1	1
46	O-ring	Buna	n/a	n/a	1	1
47	bolt	304 stainless	n/a	n/a	1	1

Horizontal Double Acting Stainless Steel Actuator

- Excellent protection and corrosion resistance
- Tested to 1 million cycles
- 100% fully tested prior to shipment
- Backed by one year manufacturer's warranty
- Designed for the B5102 series butterfly valves sizes 1" - 4"
- Can be mounted on most Bradford™ BFV's up to 4"
- 6" and 8" valves must use a horizontal rack and pinion style actuator due to torque requirements
- Available in air to open / air to close (ATO/ATC)



Dimensions

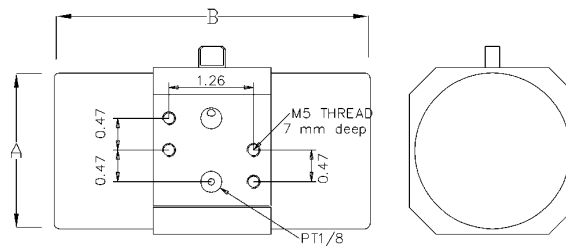

SIZES	DESCRIPTION		PART NUMBER
	A	B	
1" - 2"	2.4	3.2	RP-BS-050-DA
2½" - 4"	4.6	6.1	RP-BS-075-DA

Note: All dimensions are in inches. Dimensions are approximate. Engineering dimensions are available upon request.

Specifications are subject to change without notice.

MATERIALS LIST

ITEM	DESCRIPTION	MATERIAL	QTY
1	body	304 stainless	1
2	cylinder	304 stainless	2
3	pinion	304 stainless	1
4	piston	aluminum	2
5	lower bushing	17-4PH	1
6	upper bushing	17-4PH	1
7	piston ring	PTFE	2
8	pinion	high carbon steel	2
9	bolt	high carbon steel	2
10	bolt ring	high carbon steel	2
11	arm	high carbon steel	2
12	connector	304 stainless	2
13	body seal	NBR	2
14	cap seal	NBR	2
15	piston seal	NBR	2
16	bushing seal	NBR	1
17	pinion seal	NBR	1
18	ub seal	NBR	1
19	set screw	high carbon steel	2
20	flat head screw	304 stainless	1
21	socket head screw	304 stainless	1
22	indicator	aluminum	1

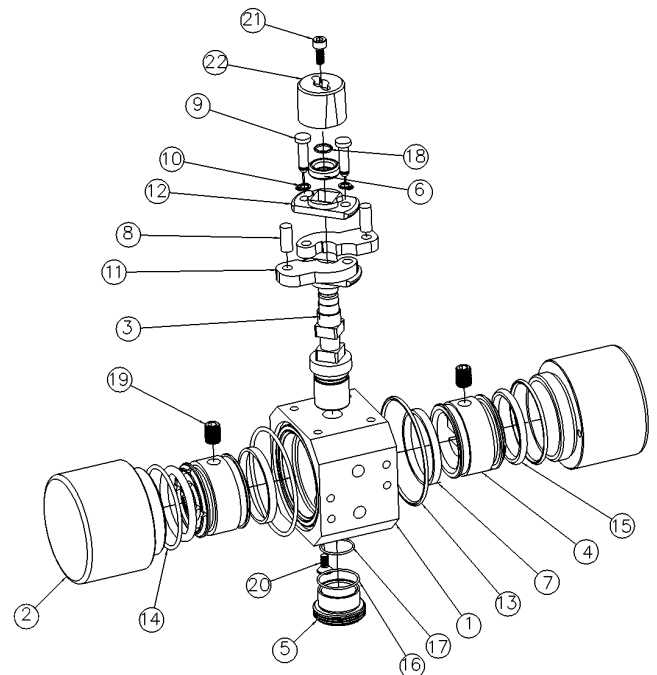

Horizontal Rack and Pinion Stainless Steel Actuator



- Replaceable top and bottom PTFE pinion bearings ensure low friction, stability above 400°F, and chemical resistance
- Travel stops provide 4° travel adjustment
- Precision cast stainless steel pistons are guided through full face engagement with the pinion and piston guide
- NAMUR slotted shaft is standard to provide a self-centering positive drive for positioners, a variety of switches
- Drive pinion is one piece stainless steel alloy shaft, precision machined gear and teeth for precise control
- ISO 5211 mounting
- Available in:
 - Air to open / air to close (ATO/ATC)
 - Air to open / spring to close (ATO/STC)
 - Spring to open / air to close (STO/ATC)

Dimensions (inches)

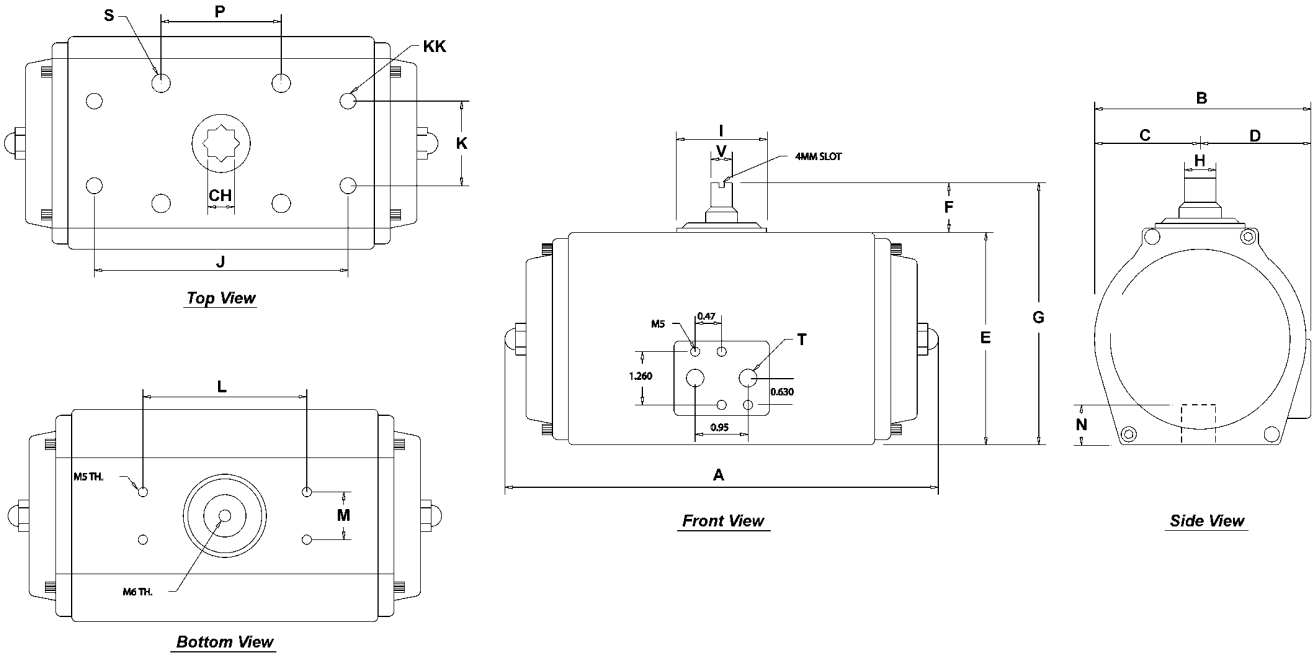

PART NO.	A	A (SR)	B	C	D	E	F	G	CH	J	L	N	M	P	S	T	V	KK
RP-BS-45 *	6.54	7.56	2.56	1.15	1.15	2.56	0.787	3.34	0.433	1.42	3.15	0.58	1.181	1.97	10-24	1/4" NPT	0.633	1/4 x 20
RP-BS-65 *	7.00	7.34	2.92	1.39	1.39	3.18	0.787	3.97	0.551	1.97	3.15	0.59	1.181	n/a	1/4 x 20	1/4" NPT	0.633	n/a
RP-BS-80 *	7.81	8.37	3.97	1.91	1.91	4.24	0.787	5.03	0.748	1.97	3.15	0.66	1.181	2.76	1/4 x 20	1/4" NPT	0.635	5/16 x 18
RP-BS-105 *	9.91	10.53	4.75	2.29	2.29	5.23	0.787	6.02	0.748	2.76	3.15	0.77	1.181	n/a	5/16 x 18	1/4" NPT	0.629	n/a
RP-BS-125 *	11.66	12.20	5.39	2.69	2.69	6.09	1.181	7.27	0.866	2.76	5.12	0.97	1.181	4.02	3/8 x 16	1/4" NPT	0.865	3/8 x 16
RP-BS-140*	14.17	19.29	6.26	3.11	3.11	6.89	1.181	8.07	1.063	4.02	5.12	1.18	1.181	4.92	3/8 x 16	1/4" NPT	0.865	1/2 x 13

* - DA = double acting; - SR = spring return

Note: all dimensions are in inches. Dimensions are approximate. Engineering dimensions are available upon request.

Specifications are subject to change without notice.

Horizontal Rack and Pinion Stainless Steel Actuator

Technical Data

TORQUE RATINGS FOR DOUBLE ACTING ACTUATOR					
PART NUMBER	40 PSI / 2.76 BAR	60 PSI / 4.14 BAR	80 PSI / 5.52 BAR	100 PSI / 6.89 BAR	120 PSI / 8.27 BAR
RP-BS-045-DA	71	107	143	178	214
RP-BS-065-DA	171	256	342	427	512
RP-BS-080-DA	370	555	740	925	1110
RP-BS-105-DA	624	936	1249	1561	1873
RP-BS-125-DA	1214	1822	2429	3036	3643
RP-BS-140-DA	2034	3051	4068	5085	6102

TORQUE RATINGS FOR SPRING RETURN ACTUATOR											
PART NUMBER	SPRING PER SIDE	SPRING TORQUE		40 PSI / 2.76 BAR		60 PSI / 4.14 BAR		80 PSI / 5.52 BAR		100 PSI / BAR	
	(5 STD)	END	BREAK	END	BREAK	END	BREAK	END	BREAK	END	BREAK
RP-BS-045-SR	3	35	57	14	36	50	72	86	108	121	143
	4	47	77	--	--	30	60	66	96	101	131
	5	60	96	--	--	--	--	47	83	82	118
	6	71	115	--	--	--	--	--	--	63	107
RP-BS-065-SR	3	67	136	35	104	120	189	206	275	291	360
	4	90	182	--	--	74	166	160	252	245	337
	5	112	227	--	--	--	--	115	230	200	315
	6	135	273	--	--	--	--	--	--	154	292
RP-BS-080-SR	3	167	273	97	203	282	388	467	573	652	758
	4	223	364	--	--	191	332	376	517	561	702
	5	279	456	--	--	--	--	284	461	469	646
	6	335	547	--	--	--	--	--	--	378	590
RP-BS-105-SR	3	346	574	50	278	362	590	675	903	987	1215
	4	461	766	--	--	170	475	483	788	795	1110
	5	576	956	--	--	--	--	293	673	605	985
	6	692	1141	--	--	--	--	--	--	420	869
RP-BS-125-SR	3	651	1141	73	563	681	1171	1288	1778	1895	2385
	4	869	1522	--	--	300	953	907	1560	1514	2167
	5	1080	1902	--	--	--	--	527	1349	1134	1956
	6	1301	2283	--	--	--	--	--	--	753	1735
RP-BS-140-SR	3	808	1859	175	1226	1192	2243	2209	3260	3226	4277
	4	1071	2487	--	--	564	1980	1581	2997	2598	4014
	5	1345	3107	--	--	--	--	961	2723	1978	3740
	6	1610	3726	--	--	--	--	--	--	1359	3475

Actuator Torque Output (In. Lbs.)

Horizontal Rack and Pinion Stainless Steel Actuator

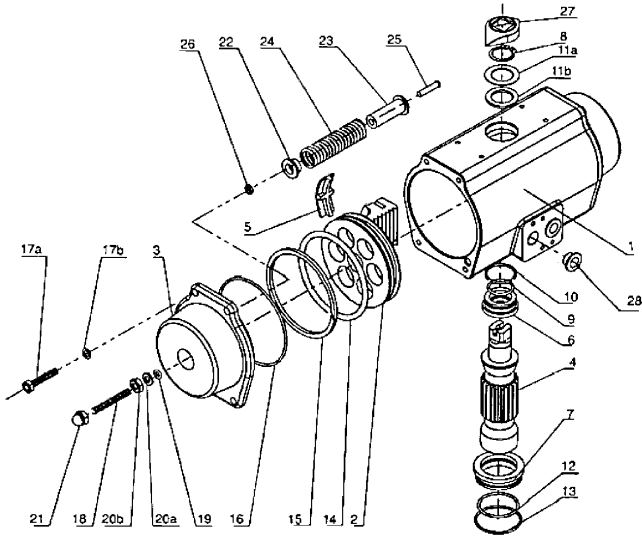

MATERIALS LIST

ITEM	DESCRIPTION	MATERIAL	QTY
1	body	stainless steel	1
2	piston	stainless steel	2
3	end caps	stainless steel	2
4	pinion	stainless steel	1
5	guide bearing	nylon 6	1
6	pinion bearing (top)	TFE	1
7	pinion bearing (bottom)	TFE	1
8	snap ring	stainless steel	1
9	O-ring (inner top)	Viton®	1
10	O-ring (outer top)	Viton®	1
11A	washer	stainless steel	1
11B	bearing	nylon 6	1
12	O-ring (inner bottom)	Viton®	1
13	O-ring (outer bottom)	Viton®	1
14	O-ring (piston)	Viton®	2
15	piston bearing	nylon 6	2
16	O-ring (end cap)	Viton®	2
17A	bolts (end cap)	stainless steel	8
17B	lock washer	stainless steel	8
18	travel stop	stainless steel	2
19	O-ring (travel stop)	Viton®	2
20A	washer	stainless steel	2
20B	nut (travel stop)	stainless steel	2
21	retaining nut	stainless steel	2
22	spring retainer	nylon 6	*
23	spring	plated carbon steel	*
24	spring	plated carbon steel	*
25	spring screw	stainless steel	*
26	spring nut	stainless steel	*
27	position indicator	nylon	1
28	port plug	nylon 6	2

G

Aluminum Rack and Pinion Actuator

- Body: Extruded hard anodized aluminum alloy for wear and corrosion resistance and reduced friction.
- Heavy Duty Springs: High tensile steel springs with retainer and guide for safe and easy assembly.
- Pistons: Die-cast aluminum alloy fitted with nylon bushing guides and Buna-N seals.
- End Caps: Epoxy-coated die-cast aluminum alloy for maximum resistance to corrosive environments.
- Pinion: Electroless nickel plated carbon steel for maximum corrosion and wear resistance.
- Rotation Adjustment: A full $\pm 5^\circ$ of travel adjustment in the open and closed positions. Standard on all sizes.
- Solenoid Interface: International NAMUR solenoid mounting interface is standard on all units.
- Indicator: A high visibility polyethylene for indication. Open/Close indication is standard on all models.
- Available in:
 - Air to open / air to close (ATO/ATC)
 - Air to open / spring to close (ATO/STC)
 - Spring to open / air to close (STO/ATC)



Double Acting



Spring Return



Dimensions for RP-BA-012-DA

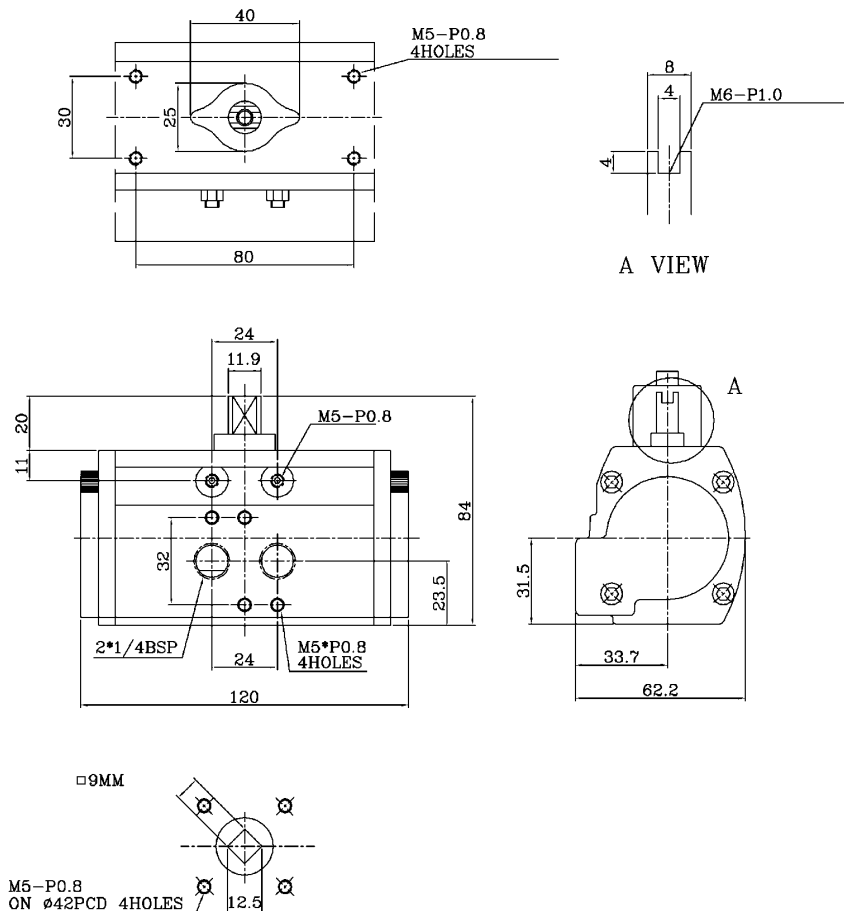

Aluminum Rack and Pinion Actuator

Dimensions for RP-BA-025-DA/SR to RP-BA-500-DA/SR

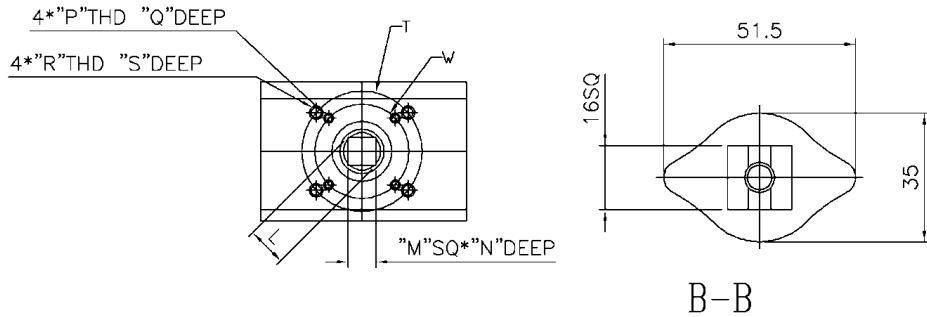
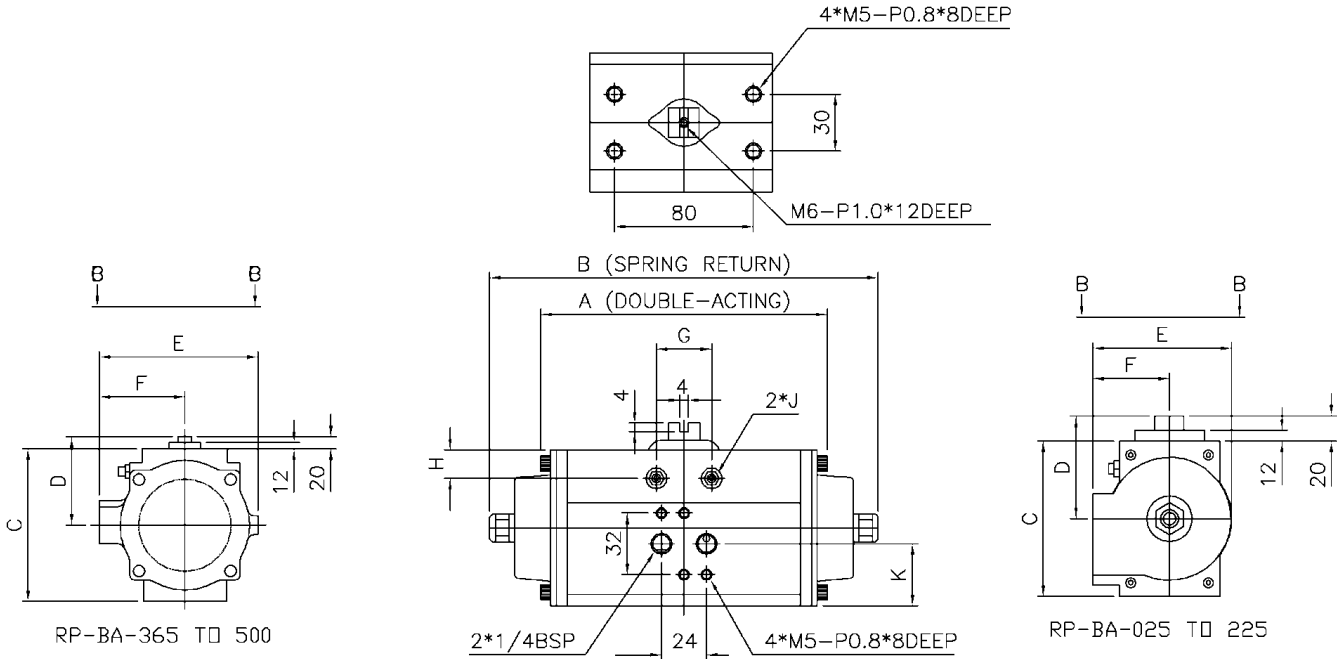

Part No.	ISO 5211	A	B	C	D	E	F	G	H	J	K	L	M	N	P	Q	R	S	T	W
RP-BA-025*	F04/F05	144.3	194.6	79	57.7	81.4	47.8	32.5	12.6	M5xP0.8	29.7	14.5	11	17	M5xP0.8	8	M6xP1.0	10	50	42
RP-BA-045*	F05/F07	149.2	205.6	98	67.4	95	51.5	32.5	13.8	M6xP1.0	30.2	18.8	14	21	M6xP1.0	10	M8xP1.25	12	70	50
RP-BA-101*	F05/F07	183	250	121	79.2	119	64.5	46.2	16.6	M8xP1.25	33.5	23	17	25.5	M6xP1.0	10	M8xP1.25	12	70	50
RP-BA-225*	F07/F10	259.6	355	141	89.5	140.5	75.5	54	18.6	M10xP1.5	39	29.5	22	31	M8xP1.25	12	M10xP1.5	15	102	70
RP-BA-365*	F10/F12	304.3	422	176	99.1	185.2	105.5	79.7	27.3	M12xP1.75	97.4	35.5	27	35	M10xP1.5	15	M12xP1.75	19	125	102
RP-BA-500*	F10/F12	364.4	487	196	116.5	204.8	107.8	79.4	28.3	M12xP1.75	99	35.5	27	35	M10xP1.5	15	M12xP1.75	19	125	102

* - DA = double acting; - SR = spring return

Aluminum Rack and Pinion Actuator

Technical Data

TORQUE RATINGS FOR DOUBLE ACTING ACTUATOR					
PART NUMBER	40 PSI / 2.76 BAR	60 PSI / 4.14 BAR	80 PSI / 5.52 BAR	100 PSI / 6.89 BAR	120 PSI / 8.27 BAR
RP-BA-012-DA	63	94	125	156	188
RP-BA-025-DA	125	187	250	312	375
RP-BA-045-DA	225	337	450	562	675
RP-BA-101-DA	500	750	1000	1250	1500
RP-BA-225-DA	1125	1687	2250	2812	3375
RP-BA-365-DA	1825	2738	3650	4563	5475
RP-BA-500-DA	2500	3750	5000	6250	7500

TORQUE RATINGS FOR SPRING RETURN ACTUATOR													
PART NO.	SPRING SET	SPRING TORQUE		40 PSI / 2.76 BAR		60 PSI / 4.14 BAR		80 PSI / 5.52 BAR		100 PSI / 6.89 BAR		120 PSI / 8.27 BAR	
		ST.	END	ST.	END	ST.	END	ST.	END	ST.	END	ST.	END
RP-BA-025-SR	2	69	45	76	47	138	109	201	172	263	234	326	312
	3	104	67	--	--	113	70	176	133	229	195	301	258
	4	140	90	--	--	88	31	151	93	213	156	276	218
	5	175	112	--	--	--	--	126	54	189	116	251	179
	6	209	135	--	--	--	--	--	--	164	77	227	139
RP-BA-045-SR	2	126	81	135	83	248	196	361	309	473	421	586	533
	3	190	121	--	--	203	125	316	238	428	350	541	463
	4	254	162	--	--	158	54	271	167	383	279	496	392
	5	317	202	--	--	--	--	226	96	339	209	451	321
	6	381	243	--	--	--	--	--	--	293	137	406	251
RP-BA-101-SR	2	279	179	300	184	549	433	798	682	1048	931	1297	1181
	3	418	270	--	--	449	278	698	526	947	775	1196	1025
	4	559	360	--	--	350	120	599	371	848	618	1097	867
	5	698	450	--	--	--	--	500	212	749	464	998	710
	6	839	540	--	--	--	--	--	--	650	304	899	557
RP-BA-225-SR	2	659	394	690	395	1253	958	1816	1521	2379	2084	2939	2647
	3	990	590	--	--	1034	591	1596	1154	2159	1717	2722	2280
	4	1320	787	--	--	816	226	1379	788	2029	1351	2505	1914
	5	1650	984	--	--	--	--	1161	424	1724	984	2287	1549
	6	1980	1181	--	--	--	--	--	--	1506	621	2069	1181
RP-BA-365-SR	2	1053	607	1152	659	2063	1570	2975	2482	3886	3393	4797	4305
	3	1573	912	--	--	1726	996	2637	1907	3549	2819	4460	3730
	4	2091	1217	--	--	1388	423	2300	1335	3211	2246	4123	3157
	5	2625	1519	--	--	--	--	1967	744	2878	1655	3789	2566
	6	3144	1824	--	--	--	--	--	--	2540	1082	3452	1994
RP-BA-500-SR	2	1560	785	1590	803	2780	1990	3970	3180	5160	4380	6350	5570
	3	2340	1180	--	--	2380	1200	3570	2400	4760	3590	5960	4780
	4	3130	1570	--	--	1980	414	3180	1600	4370	2800	5560	3990
	5	3910	1960	--	--	--	--	2780	815	3970	2010	5160	3200
	6	4690	2360	--	--	--	--	--	--	3570	1220	4760	2410

Actuator Torque Output (In. Lbs.)



Aluminum Rack and Pinion Actuator

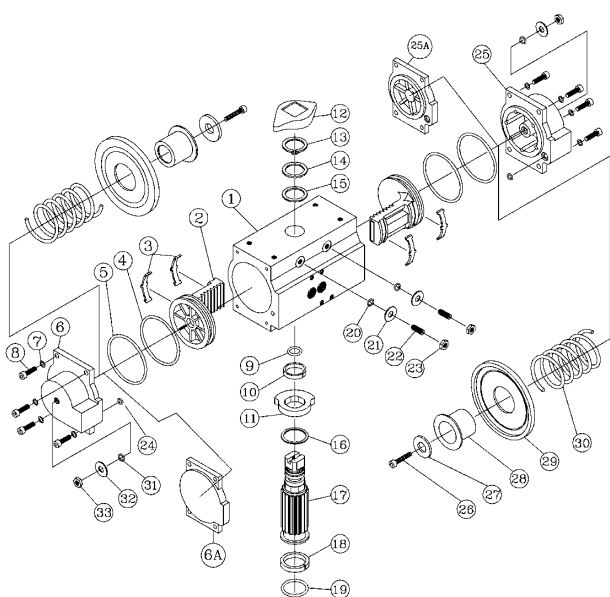

MATERIALS LIST

ITEM	DESCRIPTION	MATERIAL	QTY	
			DA	SR
1	body	anodized aluminum alloy	1	1
2	piston	die-cast aluminum alloy	2	2
3	piston bearing	nylon	4	4
4	O-ring	Buna-N	2	2
5	O-ring	Buna-N	2	2
6	end cap (left)	die-cast aluminum alloy	n/a	1
6A	end cap (left)	die-cast aluminum alloy	1	n/a
7	washer	stainless steel	8	8
8	cap screw	stainless steel	8	8
9	O-ring	Buna-N	1	1
10	bearing	nylon	1	1
11	stop cam	carbon steel	1	1
12	position indicator	polyethylene	1	1
13	retaining ring	stainless steel	1	1
14	washer	stainless steel	1	1
15	bearing	nylon	1	1
16	retaining ring	stainless steel	1	1
17	pinion	carbon steel	1	1
18	bearing	nylon	1	1
19	O-ring	Buna-N	1	1
20	O-ring	Buna-N	2	2
21	washer	stainless steel	2	2
22	stop screw	stainless steel	2	2
23	nut	stainless steel	2	2
24	O-ring	Buna-N	2	2
25	end cap (right)	die-cast aluminum alloy	n/a	1
25A	end cap (right)	die-cast aluminum alloy	1	n/a
26	screw	stainless steel	n/a	2
27	washer	stainless steel	n/a	2
28	spring guide	stainless steel	n/a	2
29	retainer	stainless steel	n/a	2
30	spring *	high tensile steel	n/a	4*
31	O-ring	Buna-N	n/a	2
32	washer	stainless steel	n/a	2
33	nut	stainless steel	n/a	2

* #4 spring set is standard

180° Aluminum Rack and Pinion Actuator

- NAMUR VDI/VDE 3845 and ISO 5211 dimensions on all sizes. No special blocks are required to mount solenoid valves, limit switches or positioners.
- The standard angle of rotation is 180°. Additional travel rotations of 120°, 135°, 150° are available. MA016 and larger sizes feature a travel stop with $\pm 10^\circ$ adjustment in both open and close directions (International Patent).
- The 'patent pending' bottom plate design, unique to Dixon Hygienic secures a captive pinion (anti-blowout system) and permits flexibility in mounting by retaining AISI 304 nuts (standard) or AISI 304 bolts (optional) In either dual ISO patterns, or to customer dimensions
- All pinions are supplied with anti-blowout retention in both directions
- The female pinion drive is standard with a double square output drive and optional with a double-D drive, keyed drive and designs to meet your specific requirements
- Shaft bearings isolate the pinion gear from the housing and support the shaft for high cycle applications
- The pinion teeth are engaged for the full length and stroke of the piston. The pinion height allows manual override without disturbing the position indication
- Extruded aluminum body is internally machined and lapped to exact specifications. All internal and external surfaces are anodized for corrosion resistance
- External open/closed indicator is standard, available for all rotations
- Pistons incorporate double wear pads to separate the rack from the actuator wall and serve as both guide and wear bearings
- Epoxy coated special steel springs are pre-loaded with non-metallic materials. The stainless steel end cap fasteners are extra long to allow for spring relaxation, all parts are corrosion resistant



Double Acting



Spring Return

- Air pressure operation from 40 to 150 PSI. Water, nitrogen and compatible hydraulic fluids may as be used to power the actuator
- All external fasteners are corrosion resistant stainless steel
- All units are permanently lubricated at the factory with non-silicone grease
- All units are externally stamped with a progressive traceable serial number
- 100% of all units are factory pressure and leak tested

SPECIFICATIONS

Operating pressure range	40 to 120 PSIG / 2.75 - 8.25 BAR
Maximum allowable working pressure	150 PSIG / 10.35 BAR
Operating media	Dry or lubricated non-corrosive gas
Operating temperature standard	-40°F to 176°F
Piston and pinion lubrication	Non-silicone grease
Range of rotation adjustment	Between 170° and 190° / 40°C - 80°C
Valve and accessory mounting	Standard ISO 5211 bolt patterns
Output shaft	Female – Double square
Design	Twin rack and pinion
Factory testing cycles	1 million

180° Aluminum Rack and Pinion Actuator

Dimensions for Double Acting

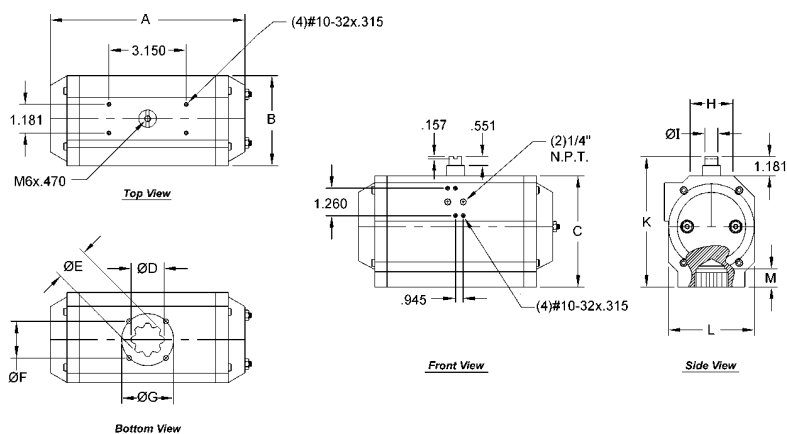

PART NO.	DIMENSIONS (inches)											
	A	B	C	D (mm)	E (mm)	F	G	H	I	K	L	M
RP-MA-012-DA	4.7	2.6	2.8	11	11	n/a	F04	1.9	0.5	4	2.1	0.5
RP-MA-016-DA	9.2	3.3	3.5	14	14	n/a	F05	1.7	0.5	4.8	2.8	0.7
RP-MA-017-DA	10.8	3.3	3.5	14	14	n/a	F05	1.7	0.5	4.8	2.8	0.8
RP-MA-021-DA	9.9	3.8	4.5	17	17	n/a	F07	1.8	0.6	5.6	3.4	0.9
RP-MA-026-DA	13	3.8	4.4	17	17	n/a	F07	1.8	0.8	5.6	3.4	0.9
RP-MA-031-DA	13	4.5	5.2	17	17	n/a	F07	2.3	0.8	6.4	4.1	0.9
RP-MA-036-DA	13.7	5.4	6.5	22	22	F07	F10	2.6	0.8	7.7	5.2	1.2
RP-MA-041-DA	15.8	5.4	6.5	22	22	F07	F10	2.6	1.1	7.7	5.2	1.2
RP-MA-046-DA	20	5.9	7	22	22	F07	F10	3	1.1	8.2	5.7	1.2
RP-MA-051-DA	19.6	7.3	8.5	27	27	n/a	F12	4	1.1	9.8	7.2	1.5
RP-MA-056-DA	23.9	7.3	8.5	27	27	n/a	F12	4	1.1	9.8	7.2	1.5

Dimensions for Spring Return

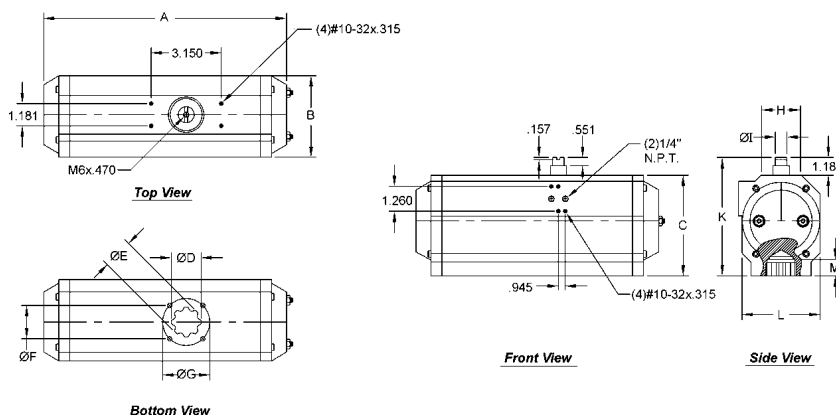

PART NO.	DIMENSIONS (inches)											
	A	B	C	D (mm)	E (mm)	F	G	H	I	K	L	M
RP-MA-015-SR	10.85	3.35	3.54	14	14	n/a	F05	1.70	0.50	4.76	2.76	0.70
RP-MA-017-SR	12.82	3.35	3.54	14	14	n/a	F05	1.70	0.50	4.76	2.76	0.80
RP-MA-020-SR	11.69	3.78	4.41	17	17	n/a	F07	1.80	0.60	5.63	3.39	0.90
RP-MA-025-SR	15.53	3.78	4.41	17	17	n/a	F07	1.80	0.80	5.63	3.39	0.90
RP-MA-030-SR	15.20	4.45	5.16	17	17	n/a	F07	2.30	0.80	6.38	4.09	0.90
RP-MA-035-SR	16.04	5.43	6.50	22	22	F07	F10	2.60	0.80	7.72	5.16	1.20
RP-MA-040-SR	18.80	5.43	6.50	22	22	F07	F10	2.60	1.10	7.72	5.16	1.20
RP-MA-045-SR	23.15	5.95	6.97	22	22	F07	F10	3.00	1.10	8.19	5.75	1.20
RP-MA-050-SR	23.41	7.28	6.97	27	27	n/a	F12	4.00	1.10	9.76	7.17	1.50
RP-MA-055-SR	27.70	7.28	8.54	27	27	n/a	F12	4.00	1.10	9.76	7.17	1.50

180° Aluminum Rack and Pinion Actuator

Technical Data

TORQUE RATINGS FOR SPRING RETURN ACTUATOR													
PART NO.	SPRING SET	OPENING TORQUE		CLOSING TORQUE									
				40 PSI / 2.76 BAR		60 PSI / 4.14 BAR		80 PSI / 5.52 BAR		100 PSI / 6.89 BAR		120 PSI / 8.27 BAR	
		START	END	START	END	START	END	START	END	START	END	START	END
RP-MA-015-SR	2+2	75	53	84	62	153	131	222	200	291	269	359	337
	3+3	112	81	56	25	125	94	194	163	263	232	331	300
	4+4	150	107	--	--	99	56	168	125	237	194	305	262
	5+5	187	134	--	--	72	19	141	88	210	157	278	225
	7+5	224	160	--	--	--	--	115	51	184	120	252	188
RP-MA-017-SR	2+2	93	64	116	87	206	177	296	267	386	357	476	447
	3+3	139	96	84	41	174	131	264	221	354	311	444	401
	4+4	185	128	--	--	142	85	232	175	322	265	412	355
	5+5	232	160	--	--	110	38	200	128	290	218	380	308
	7+5	278	192	--	--	--	--	168	82	258	172	348	262
RP-MA-020-SR	2+2	122	92	158	128	283	253	408	378	533	503	658	628
	3+3	184	138	112	66	237	191	362	316	487	441	612	566
	4+4	245	184	66	5	191	130	316	255	441	380	566	505
	5+5	307	230	--	--	145	68	270	193	395	318	520	443
	7+5	369	278	--	--	97	6	222	131	347	256	472	381
RP-MA-025-SR	2+2	196	124	251	179	438	366	626	554	813	741	1001	929
	3+3	294	185	190	81	377	268	565	456	752	643	940	831
	4+4	392	247	--	--	315	170	503	358	690	545	878	733
	5+5	490	309	--	--	253	72	441	260	628	447	816	635
	7+5	588	372	--	--	--	--	378	162	565	349	753	537
RP-MA-030-SR	2+2	251	187	313	249	563	499	813	749	1063	999	1313	1249
	3+3	376	280	220	123	470	374	720	624	970	874	1220	1124
	4+4	502	374	--	--	376	248	626	498	876	748	1126	998
	5+5	627	467	--	--	283	123	533	373	783	623	1033	873
	7+5	753	560	--	--	--	--	440	247	690	497	940	747
RP-MA-035-SR	2+2	412	306	494	388	894	788	1294	1188	1694	1588	2094	1988
	3+3	617	461	339	183	739	583	1139	983	1539	1383	1939	1783
	4+4	824	614	--	--	586	376	986	776	1386	1176	1786	1576
	5+5	1029	767	--	--	433	171	833	571	1233	971	1633	1371
	7+5	1236	921	--	--	--	--	679	364	1079	764	1479	1164
RP-MA-040-SR	2+2	505	371	629	495	1129	995	1629	1495	2129	1995	2629	2495
	3+3	757	556	444	243	944	743	1444	1243	1944	1743	2444	2243
	4+4	1011	741	--	--	759	489	1259	989	1759	1489	2259	1989
	5+5	1263	929	--	--	572	237	1072	737	1572	1237	2072	1737
	7+5	1516	1113	--	--	--	--	887	484	1387	984	1887	1484
RP-MA-045-SR	2+2	890	560	1002	672	1784	1454	2565	2235	3346	3016	4127	3797
	3+3	1334	840	722	228	1504	1010	2285	1791	3066	2572	3847	3353
	4+4	1779	1120	--	--	1224	565	2005	1346	2786	2127	3567	2908
	5+5	2224	1399	--	--	945	120	1726	901	2507	1682	3288	2463
	7+5	2669	1679	--	--	--	--	1446	456	2227	1237	3008	2018
RP-MA-050-SR	2+2	1101	869	1381	1149	2506	2274	3631	3399	4756	4524	5881	5649
	3+3	1652	1304	946	598	2071	1723	3196	2848	4321	3973	5446	5098
	4+4	2203	1738	512	47	1637	1172	2762	2297	3887	3422	5012	4547
	5+5	2754	2173	--	--	1202	621	2327	1746	3452	2871	4577	3996
	7+5	3303	2607	--	--	768	72	1893	1197	3018	2322	4143	3447
RP-MA-055-SR	2+2	1487	1055	1945	1513	3445	3013	4945	4513	6445	6013	7945	7513
	3+3	2231	1583	1417	769	2917	2269	4417	3769	5917	5269	7417	6769
	4+4	2974	2111	889	26	2389	1526	3889	3026	5389	4526	6889	6026
	5+5	3718	2638	--	--	1862	782	3362	2282	4862	3782	6362	5282
	7+5	4462	3166	--	--	1334	38	2834	1538	4334	3038	5834	4538

Actuator Torque Output (In. Lbs.)



Electric Actuation



Features

- Conforms to CSA-C for outdoor use
- Built by an ISO9001 certified manufacturer

Enclosure

- Lightweight powder coated aluminum alloy with plastic cover
- NEMA 4 and 4X waterproof and dust proof
- ROHS compliant

Motor

- Extended duty cycle induction motor
- H-insulation class OM-1 and OM-A Class F on OM-2 to OM-4
- Built in thermal protection prevents motor burn out
- Includes position indicators on top of unit

Manual Override

- Non-clutch design allows manual operation in a power outage
- Fail-safe does not allow manual operation when electric motor is operating
- Some units feature a hand wheel for manual operation
- Optional battery back-up available

High alloy steel gear train

- Provides self-locking function to avoid valve back drive
- Factory installed high temperature lubricant, reduces maintenance

Additional Features

- Tested to one million cycles
- One year manufacturer's warranty
- All units include heater to reduce condensation

Electric Actuation

Dimensions

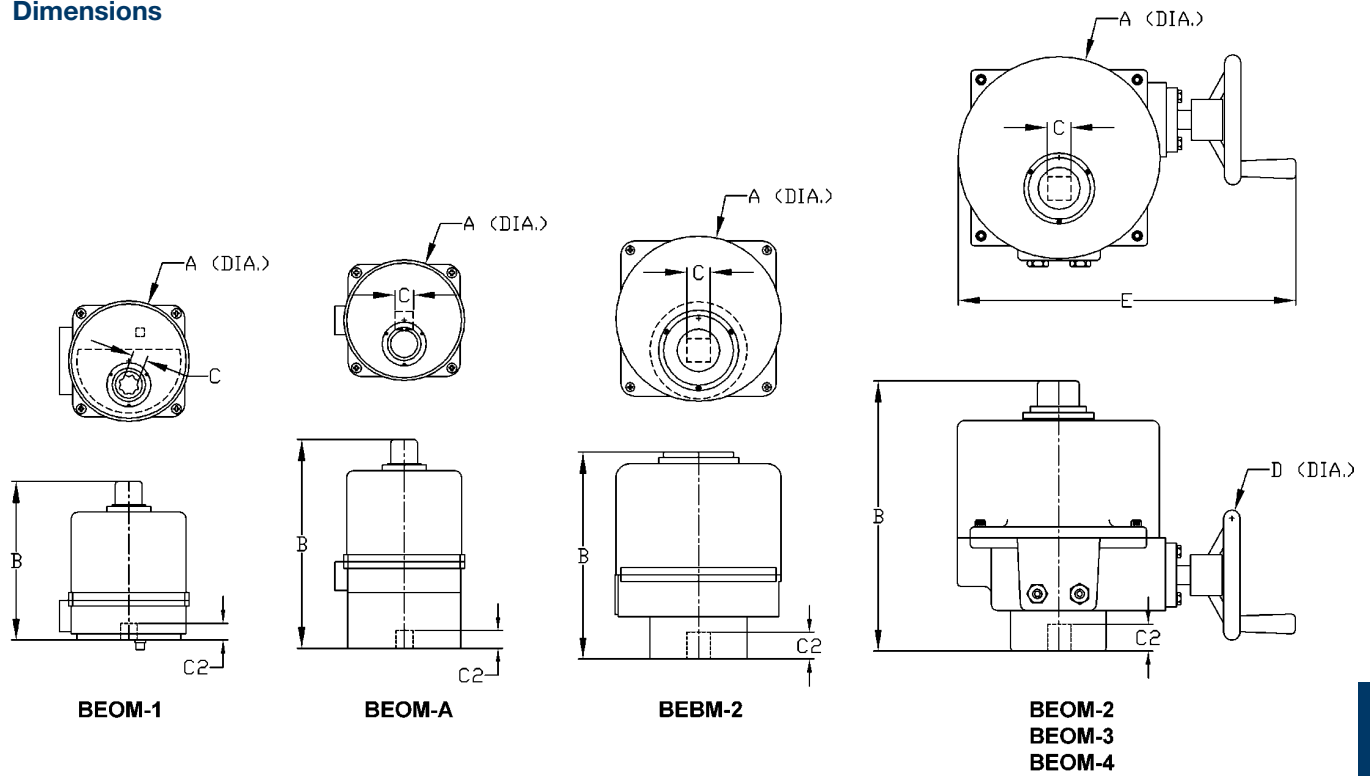

PART NO.	INCHES (MM)						FLANGE TYPE
	A Ø	B	C SQ MAXIMUM	C2 DEPTH	D Ø	E	
BEOM-1	4.5 (114)	6.1 (155)	0.6 (14)	0.6 (15)	---	---	F03 / F05
BEOM-A	4.5 (114)	8.0 (203)	0.7 (17)	0.6 (16)	---	---	F07
BEBM-2	6.1 (154)	7.6 (192)	0.9 (22)	1.2 (30)	---	---	F07
BEOM-2 BEOM-3	7.1 (180)	10.0 (255)	0.9 (22)	1.2 (30)	4.8 (123)	12.8 (326)	F07
BEOM-4	8.5 (217)	12.5 (317)	1.4 (35)	1.6 (40)	7.6 (194)	15.5 (394)	F10

Bradford™ Seat Valves

The Bradford SV-series single seat valves offer a true hygienic design to meet your most demanding process applications. The SV-series valves are offered in 316L stainless steel with a variety of body configurations and seat and stem seal materials to fit your specific needs.

This valve series is designed to shut off or divert the flow in your process either remotely by using air or locally using a manual operating device. The rugged design of the actuator and valve body allow the valve to stand up to the harsh environments often found in the sanitary industry.

Product Specifications

- Size range:** 1", 1½", 2", 2½", 3"
- Materials:**
- Body - 316 stainless steel
 - Actuator - 316 stainless steel
 - Manual Operating Device - 316 stainless steel
 - Stem Seal - EPDM, silicone, Viton®
 - Seat Seal - EPDM, silicone, Viton
- Options:**
- Manual
 - Actuated (spring return, double acting)
 - Control Tops
- Body Types:**
- L, T, Y, F, L/L, T/L, L/T, T/T, Tank Bottom
- Technical Data:**
- Temperature range -45°C (-50°F) to 100°C (212°F)
 - Surface Finish <32Ra standard
 - Max product pressure
 - 1" to 1½" 450 PSI
 - 2" 400 PSI
 - 2½" to 3" 350 PSI
 - Air pressure 80 to 145 PSI
 - Air connections 1/8" FNPT



Body Configurations

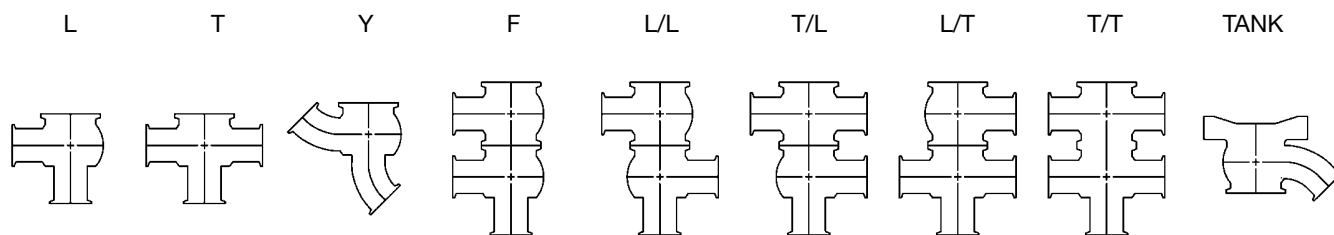

CT-Series Control Top

The Bradford CT series control top mounts directly to the SV series spring return actuator offering two position feedback and control

- Nema 4/4X water proof / dust proof class IP 67 enclosure
- 304SS enclosure
- 110VAC and 24VDC solenoid options
- Mechanical and proximity (PNP, NPN, NO & NC) switching options

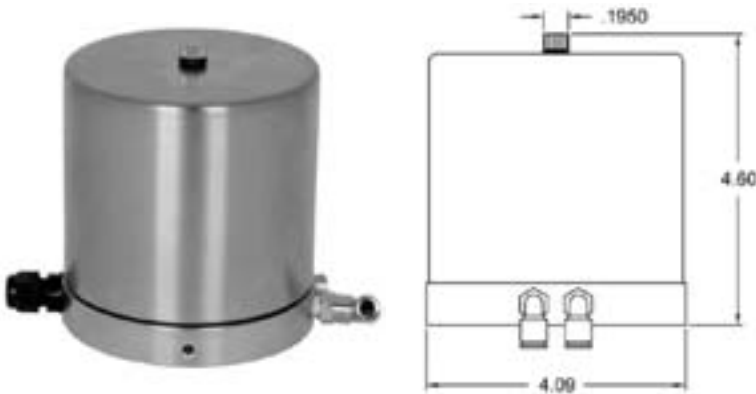

PART NO.	Description
SV-CT1	Micro Switch 24Vdc, Air To Lower
SV-CT2	Prox Npn Nc 24Vdc, Air To Lower
SV-CT3	Prox Npn No 24Vdc, Air To Lower
SV-CT4	Prox Pnp Nc 24Vdc, Air To Lower
SV-CT5	Prox Pnp No 24Vdc, Air To Lower
SV-CT6	Micro Switch 24Vdc, Air To Rise
SV-CT7	Prox Npn Nc 24Vdc, Air To Rise
SV-CT8	Prox Npn No 24Vdc, Air To Rise
SV-CT9	Prox Pnp Nc 24Vdc, Air To Rise
SV-CT10	Prox Pnp No 24Vdc, Air To Rise
SV-CT11	Micro Switch 110Vac, Air To Lower
SV-CT12	Prox Npn Nc 110Vac, Air To Lower
SV-CT13	Prox Npn No 110Vac, Air To Lower
SV-CT14	Prox Pnp Nc 110Vac, Air To Lower
SV-CT15	Prox Pnp No 110Vac, Air To Lower
SV-CT16	Micro Switch 110Vac, Air To Rise
SV-CT17	Prox Npn Nc 110Vac, Air To Rise
SV-CT18	Prox Npn No 110Vac, Air To Rise
SV-CT19	Prox Pnp Nc 110Vac, Air To Rise
SV-CT20	Prox Pnp No 110Vac, Air To Rise

CM-Series Control Top

The CM Series Control Top Communication Module, designed for corrosive process environments, attaches directly to the Bradford Sanitary Divert Valves. This platform offers a full array of communication and switching options as well as discrete integral pneumatic control for spring return actuator operation.

Features and Benefits:

- The CM Series may be washed down and temporarily submersed with no adverse affects. It is rated NEMA 4, 4x, and 6. It may be used in Div. 2/Zone 2 areas (Nonincendive) or Div.1/Zones 0 & 1 (Intrinsically Safe) hazardous applications
- Enclosure features high strength polycarbonate with excellent corrosion resistance and exceptional temperature stability
- Visual electronic and mechanical position indication confirm valve and switch status for added safety
- Solid state proximity sensors monitor Open/Closed discrete valve position with precision and reliability
- Integral pneumatic valve is isolated from environmental contamination, offers high tolerance to dirty air and enables rapid valve operation
- Solenoid options available for 120VAC and 24VDC. Select Piezo option for bus powered Foundation Fieldbus Applications
- Self Adjusting triggering system provides consistent Open and Closed indication. No resetting is required
- Manual override enables valve operation without electrically energising
- Dual module system seals all position sensing, communication and control electronics in a compact vibration proof package
- NPT port connections are stainless steel reinforced for long life sealing under high torque stress conditions
- Water proof quick connectors, compression fittings or conduit connections are available for convenient, reliable attachment to plant electrical systems

BC-Series Sanitary Centrifugal Pumps

- Pump and all spare parts are completely interchangeable with all Sanitary C-Series pumps
- Pump model and component part numbers are familiar and easy to use - BC114, BC216, etc.
- Most complete pumps ship in 1 week
- Stocked repair kits: #1, #3, DG and #4 (all-in-one)



Beverage



Dairy



Oils



Water



Cosmetics



CIP Solutions

Mechanical Specifications

Standard Construction

- Volute: 316L stainless steel
- Impeller: CF8M (316) stainless steel
- Backplate: 316L stainless steel
- Stub Shaft: 316L stainless steel
- Adapter: 304 stainless steel
- Optional Leg Kit: 304 stainless steel
- Seal Types: externally balanced 'D' & 'DG' with clamped in seat
- Rotary Seal Material: carbon
- DG Seal Seat Material: silicone carbide, ceramic and tungsten carbide
- Elastomers: EPDM, silicone and Viton®
- Finish: Hygienic polish 32RA

Model	Inlet	Outlet	Maximum Impeller
BC114	1½" or 2"	1½"	4"
BC216	2" or 2½"	1½"	6"
BC218	2" or 3"	1½"	8"
BC328	3" or 4"	2"	8"

Performance Characteristics

- Nominal Capacity: up to 780 GPM
- Temperature: 0°C - 100°C, consult factory for other temperatures
- Nominal speed: up to 3500 RPM - 60 Hz

Motors and Mounting

- Motor: standard C-face, 1750 & 3450 RPM, TEFC and washdown, foot mounted
- Additional motor types available upon request
- Mounting: pump head mounted to a C-Face motor

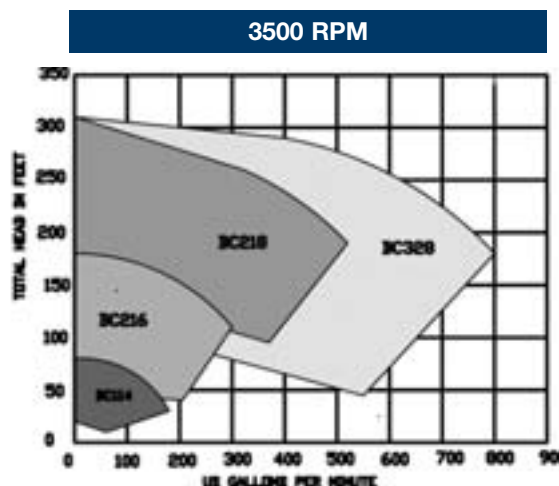
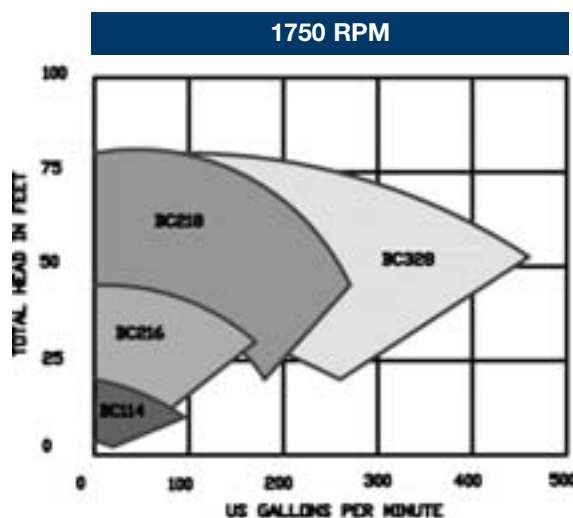

Hygienic Filter / Strainers Product Specifications

- Size range:** • 1" - 3" clamp
- Materials:** • Inline
- short
- long
- Side Entry
- long
- Materials:** • 316L stainless steel
- Finish:** • 3A sanitary, ID and OD



What Are Filter / Strainers Used For?

Filter Definition

A filter uses a disposable media to remove finer particulate from the stream. Dixon Sanitary holds Authorization Number 1446 for the 3-A Sanitary Standard for Filters using Single Service Filter Media, Number: 10-4.

Strainer Definition

A strainer is a device used to separate solids from fluids. Here it is used for larger particulate matter from liquid or gas. It uses cleanable media.



Full Flow Filters -

Can be equipped with a variety of filtering media, down to 40 microns, media includes polyester, cotton cheesecloth and nylon mesh.



Full Flow Coarse Strainers -

1/4" or 1/8" perforations.



Full Flow Fine/Medium Strainers -

Can be equipped with a variety of mesh screens for removing finer particles (20 to 1130 mesh).

Hygienic Filter / Strainers

- In-line units ship standard with the following: spring, distributor cap, clamp gasket, 1/4" perforated back-up tube, inlet and outlet bodies and squeeze clamp
- 1/8" perforated back-up tube available, must specify when ordering
- RJT, DIN, Clamp, IDF, SMS weld ends available, call Dixon Europe for information



SHORT PART NUMBER	LONG PART NUMBER	SIZE	A SHORT	A LONG	B
BSCCQ1-R100	---	1"	15.75	--	4.00
BSCCQ1-R150	BSCCQ2-R150	1½"	15.75	35.75	4.00
BSCCQ1-R200	BSCCQ2-R200	2"	15.75	35.75	4.00
BSCCS1-R250	---	2½"	15.75	--	4.50
BSCCS1-R300	BSCCS2-R300	3"	15.75	35.75	4.50

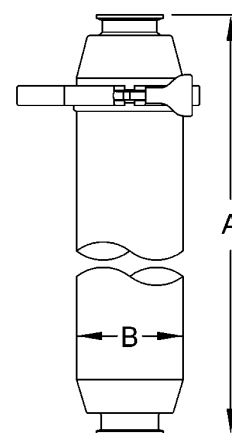

Dimensions are approximate. Engineering dimensions are available upon request. Specifications are subject to change without notice.

G

Bill of Materials

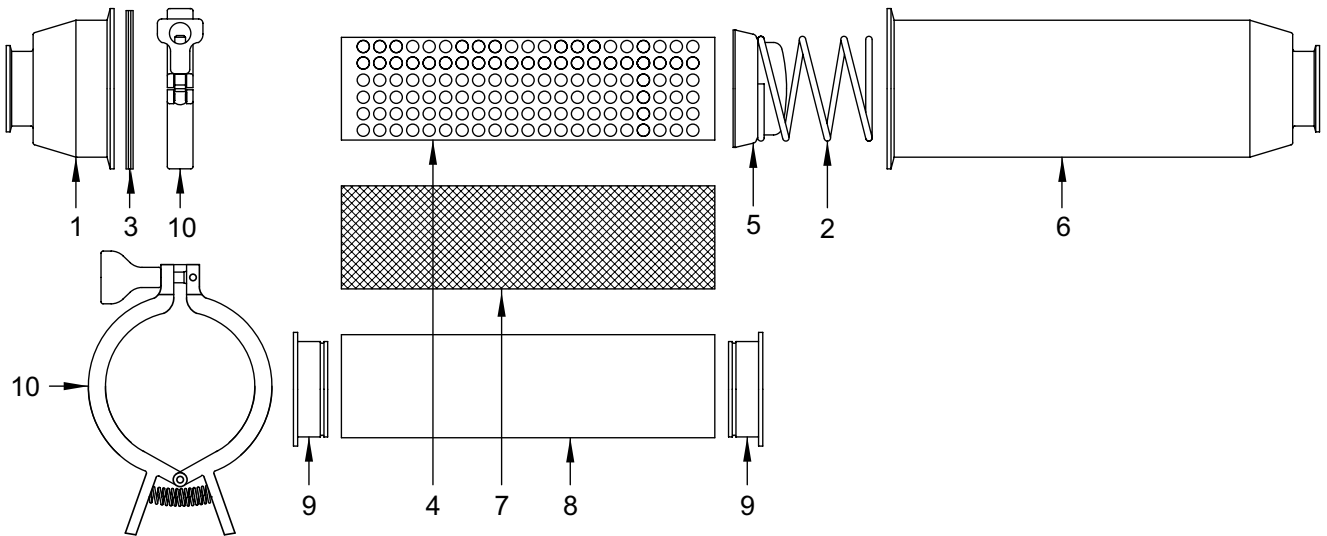

ITEM NO.	DESCRIPTION	SHORT PART NO.	LONG PART NO.	MATERIAL	QTY
1	1" strainer outlet	BS-01-R100	---	316L stainless steel	1
	1½" strainer outlet	BS-01-R150			
	2" strainer outlet	BS-01-R200			
	2½" strainer outlet	BS-01-R250	---		
	3" strainer outlet	BS-01-R300			
2	1"-2" strainer spring	BS-02-R100-200	BS-02-R100-200	316L stainless steel	1
	2½"-3" strainer spring	BS-02-R250-300	BS-02-R250-300		
3	4" clamp gasket	40MP-U400		Buna	1
	4" schedule 5 clamp gasket	40MPV-U400			
4	1"-2" back-up tube with 1/8" perforations	BS-1418-R100-200	BS-2418-R100-200	316L stainless steel	1
	2½"-3" back-up tube with 1/8" perforations	BS-1418-R250-300	BS-2418-R250-300		
	1"-2" back-up tube with 1/4" perforations	BS-1425-R100-200	BS-2425-R100-200		
	2½"-3" back-up tube with 1/4" perforations	BS-1425-R250-300	BS-2425-R250-300		
5	1"-2" strainer cap	BS-05-R100-200		316L stainless steel	1
	2½"-3" strainer cap	BS-05-R250-300			
6	1" strainer inlet	BS-16-R100	---	316L stainless steel	1
	1½" strainer inlet	BS-16-R150	BS-26-R150		
	2" strainer inlet	BS-16-R200	BS-26-R200		
	2½" strainer inlet	BS-16-R250	---		
	3" strainer inlet	BS-16-R300	BS-26-R300		
7	1"-3" various mesh over screens (short/long)	part number on page 95		316 stainless steel	1
8	1"-3" various filter bag (short/long)	part number on page 95		various	1
9	1"-2" retaining ring used with filter bags	BS-09-U100-200		Buna	2
	2½"-3" retaining ring used with filter bags	BS-09-U250300			
10	4" squeeze clamp for 1"-2" assembly	13MHHM-Q400		CF8	1
	4" schd. 5 squeeze clamp 2½"-3" assembly	13MHHV-Q400			

Hygienic Filter / Strainers

- Side entry units ship standard with the following: spring, end cap with handle, distributor cap, clamp gasket, 1/4" perforated back-up tube, body and squeeze clamp
- 1/8" perforated back-up tube available, must specify when ordering
- RJT, DIN, Clamp, IDF, SMS weld ends available, call Dixon Europe for information



PART NUMBER	SIZE	A	B	C	D
BSCCQ3-R150	1½"	41.9	4	35	3½
BSCCQ3-R200	2"	41.9	4	35	3½
BSCCQ3-R300	3"	41.9	4½	35	3¾

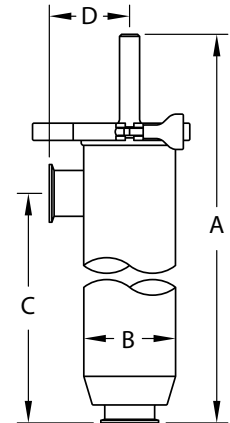

Dimensions are approximate. Engineering dimensions are available upon request. Specifications are subject to change without notice.

G

Bill of Materials

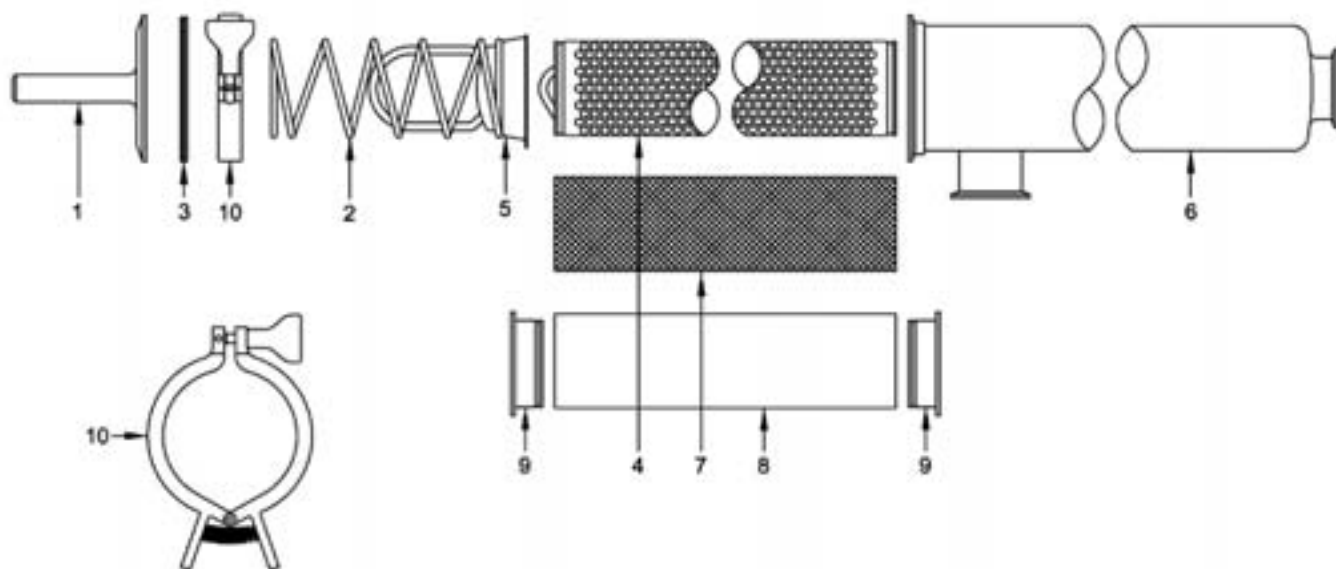

ITEM NO.	DESCRIPTION	1½" AND 2" PART #	3" PART #	MATERIAL	QTY
1	end cap with handle	BS-31-R100-200	BS-31-R250-300	316L stainless steel	1
2	strainer spring	BS-32-R100-200	BS-32-R250-300	316L stainless steel	1
3	clamp gasket	40MP-U400	40MPV-U400	Buna	1
4	back-up tube with 1/8" perforations	BS-1418-R100-200	BS-2418-R100-200	316L stainless steel	1
	back-up tube with 1/4" perforations	BS-1425-R100-200	BS-2425-R100-200		
5	distributor cap	BS-35-R100-200	BS-35-R250-300	316L stainless steel	1
6	1½" strainer body	BS-36-R150	---	316L stainless steel	1
	2" strainer body	BS-36-R200	---		
	3" strainer body	---	BS-36-R300		
7	various mesh over screens	part number on page 95		316 stainless steel	1
8	various filter bag	part number on page 95		various	1
9	retaining ring used with filter bags	BS-09-U100-200	BS-09-U250300	Buna	2
10	squeeze clamp for assembly	13MHM-Q400	13MHHV-Q400	CF8	1

Replacement Filters

- Filter medium are special order and minimum quantities apply. Not included with base unit.

SIZE	MICRON RATING	DESCRIPTION	SHORT PART NUMBER	LONG/SIDE ENTRY PART NUMBER
1" - 2"	38	nonwoven rayon (glued seam)	BF30A-100-200	BF302A-100-200
2½" - 3"	38	nonwoven rayon (glued seam)	BF30A-250-300	BF302A-250-300
1" - 2"	513	woven knapped cotton flannel	BF30B-100-200	BF302B-100-200
2½" - 3"	513	woven knapped cotton flannel	BF30B-250-300	BF302B-250-300
1" - 2"	300	cheese cloth, single thickness cotton	BF30C-100-200	BF302C-100-200
2½" - 3"	300	cheese cloth, single thickness cotton	BF30C-250-300	BF302C-250-300
1" - 2"	765	nylon, 26/29 mesh, rectangular opening, (.025 x .030)	BF30D-100-200	BF302D-100-200
2½" - 3"	765	nylon, 26/29 mesh, rectangular opening, (.025 x .030)	BF30D-250-300	BF302D-250-300
1" - 2"	40-42	nonwoven rayon	BF30E-100-200	BF302E-100-200
2½" - 3"	40-42	nonwoven rayon	BF30E-250-300	BF302E-250-300
1" - 2"	<40	nonwoven rayon	BF30F-100-200	BF302F-100-200
2½" - 3"	<40	nonwoven rayon	BF30F-250-300	BF302F-250-300
1" - 2"	420	woven nylon, 40 mesh	BF30G-100-200	BF302G-100-200
2½" - 3"	420	woven nylon, 40 mesh	BF30G-250-300	BF302G-250-300

G Wire Cloth Mesh Over Screens

- Not all sizes are stocked additional sizes may be available (5 piece minimum), call the factory. Not included with base unit.

SIZE	MICRON RATING	SQUARE MESH	SPACE BETWEEN WIRES	PERCENT OF OPEN AREA	SHORT PART NUMBER	LONG/SIDE ENTRY PART NUMBER
1" - 2"	864	20	0.034	46.2	BS20-100-200	BS202-100-200
2½" - 3"	864	20	0.034	46.2	BS20-250-300	BS202-250-300
1" - 2"	381	40	0.015	36.0	BS40-100-200	BS402-100-200
2½" - 3"	381	40	0.015	36.0	BS40-250-300	BS402-250-300
1" - 2"	229	60	0.009	30.3	BS60-100-200	BS602-100-200
2½" - 3"	229	60	0.009	30.3	BS60-250-300	BS602-250-300
1" - 2"	178	80	0.007	31.4	BS80-100-200	BS802-100-200
2½" - 3"	178	80	0.007	31.4	BS80-250-300	BS802-250-300
1" - 2"	140	100	0.006	30.3	BS100-100-200	BS1002-100-200
2½" - 3"	140	100	0.006	30.3	BS100-250-300	BS1002-250-300

Pressure Drop Curves for Filter and Strainer

Water at ambient temperature

- maximum flow for short units is 125 GPM

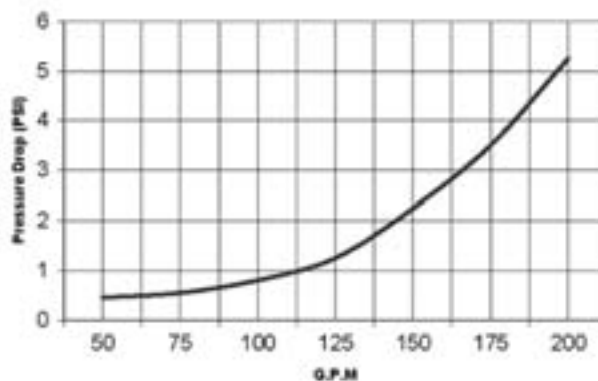

Sample Valves



Businesses from food and beverage to pharmaceutical and cosmetics can now rely on Dixon Hygienic for their sampling needs with Bradford™ sample valves.

The Dixon Hygienic sample valve is a hygienic valve for use in stainless steel process systems. These valves are simple, rugged and above all, dependable. Bradford™ sample valves are made from stainless steel and are available in various sizes, ½" to 4" offering clamp and NPT end configurations, others also available as special order.

Dixon Hygienic offers inline and angle valves with a smooth or barbed outlet depending on your need.

Economical Bradford™ sample valves are 100% factory tested for the extra security you require. Maintenance is easy using one of Dixon Hygienic's repair kits, quickly returning the valve to service.

316L Angle Sample Valve

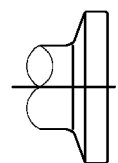
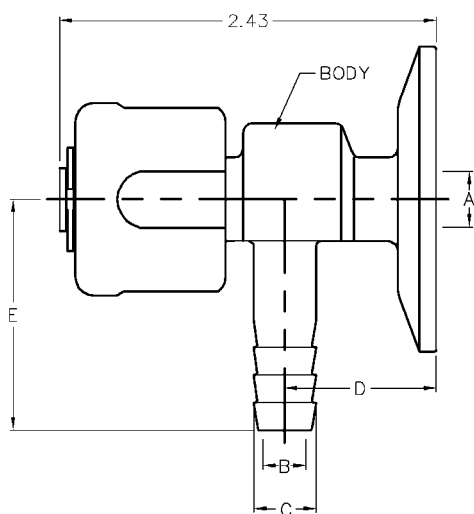

FRACTIONAL
TRI-CLAMP



- all 316L stainless wetted part construction
- standard finish to 20 Ra ID / 32 Ra OD
- Viton® stem seal FDA approved
- fully traceable (material test reports)
- domed virgin PTFE seat for positive closure
- tapered hygienic clamp connection prevents product back flow when installed in-line
- set screw stop prevents accidental removal of stem from valve body
- black nylon nut cover allows hand operation even with hot products
- minimal internal dead-leg area
- end connections available: clamp and butt weld
- sizes available: 1/2" - 1 1/2"
- temperature rating: (300°F) 149°C @ 200 PSI

SIZE		PART NUMBER	DIMENSIONS (inches)					WEIGHT (lbs)
CLAMP	BARB		A	B	C	D	E	
1/2"	1/4"	BSVACV-R050025	0.218	0.187	0.312	0.972	1.50	0.250
1/2"	3/8"	BSVACV-R050375	0.218	0.218	0.405	0.952	1.50	0.375
1/2"	1/2"	BSVACV-R050050	0.218	0.375	0.540	0.878	1.50	0.500
1"	3/8"	BSVACV-R100375	0.218	0.218	0.405	0.985	1.50	0.500
1 1/2"	1/4"	BSVACV-R150025	0.218	0.187	0.312	0.987	1.50	0.500
1 1/2"	3/8"	BSVACV-R150375	0.218	0.218	0.405	0.985	1.50	0.500
2"	1/4"	BSVACV-R200025	0.218	0.187	0.312	0.987	1.50	0.750

REPAIR KIT FOR ANGLE SAMPLE VALVE

PART NUMBER	DESCRIPTION	MATERIAL	QTY.
BSVA-RKS	seal	PTFE	1
	O-ring	Viton®	1

304 Sample Valves - BSVW*S

- 304 stainless steel
- silicone O-rings and gasket ensure a leak-proof shut-off
- surface finish polished to sanitary standards
- temperature rating: (300°F) 149°C at 200 PSI
- repair kit, BSVW-RKS, contains: (1) silicone gasket and (2) silicone O-rings



SIZE	STYLE	304 STAINLESS STEEL PART NUMBER	DIMENSIONS (inches)			OPEN	WEIGHT (lbs)
			A	B	C		
3/8"	NPT	BSVWNS-G375	0.360	0.235	0.378	3.58	0.72
1"	clamp	BSVWCS-G100	0.360	0.235	0.378	3.25	0.88
1"	butt-weld	BSVWBS-G100	0.360	0.235	0.235	3.58	0.72

G

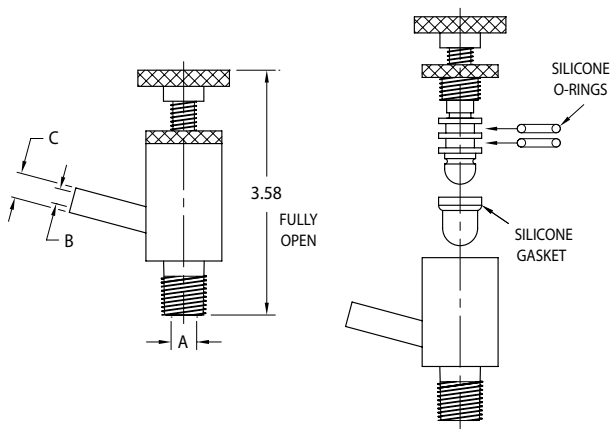

NPT style

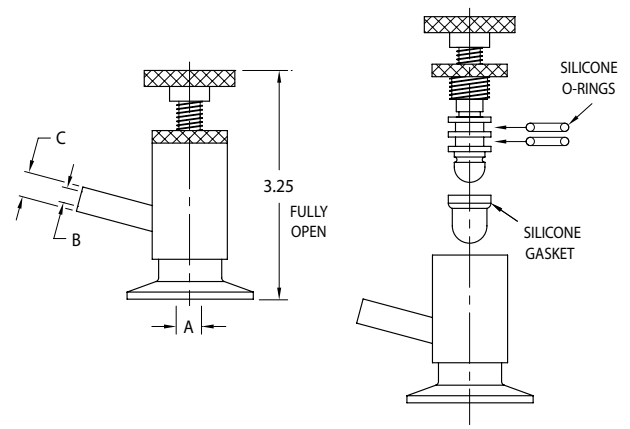

Clamp style

Fabrication and Tubing

Dixon Group Europe is now offering custom fabrications. We have full CAD capabilities and can provide a print for your approval.

Once the print is approved, Dixon will have the part created in-house or from a variety of manufacturers specialising in hygienic components.

Dixon can produce manufacturing from sketches supplied by the customer.

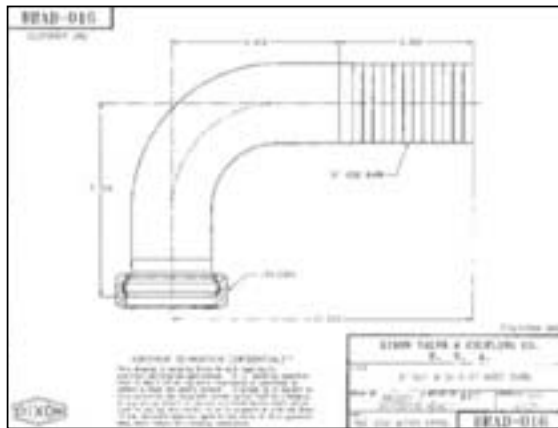
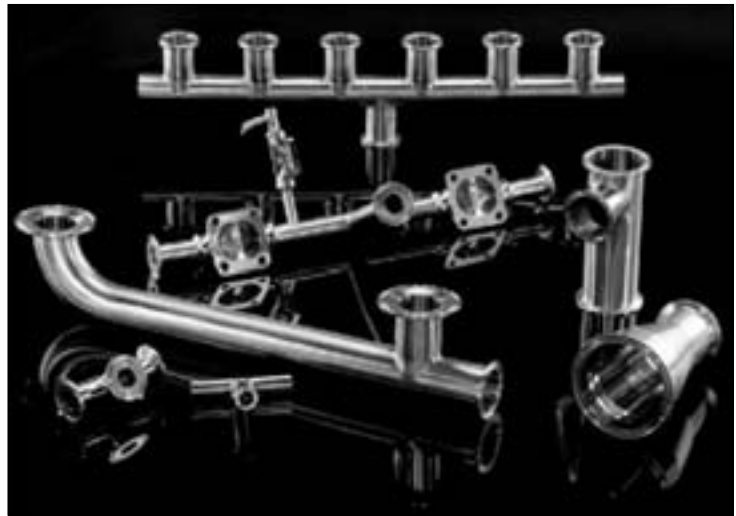

Product Specifications

- Size range:** 1/2" - 12" (12-305mm)
- Materials:**
 - 304 stainless steel
 - 316L stainless steel
 - Other alloys are available

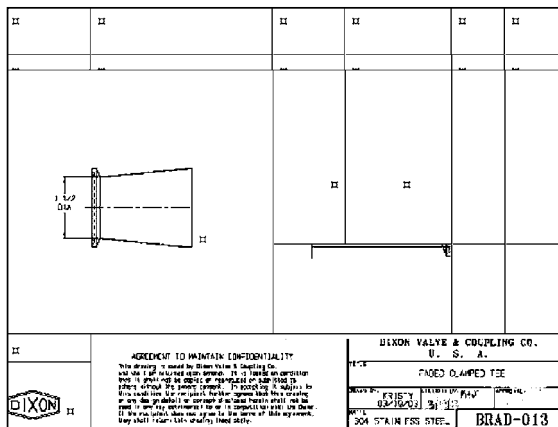

Ordering Instructions

- Specify:** Dixon Part No.
- Include a signed print
- Ship to address

ALL HYGIENIC ASSEMBLIES ARE WELDED BY AWS D18.1 "SPECIFICATIONS FOR WELDING OF AUSTENITIC STAINLESS STEEL TUBE AND PIPE SYSTEMS IN SANITARY (HYGIENIC) APPLICATIONS" CERTIFIED WELDERS

Examples of Parts Manufactured



Elbows of Various Configurations, Finishes and Materials. Welded, Polished and Machined Components



Tees of Various Configurations, Finishes and Materials



Reducers of Various Configurations, Finishes and Materials

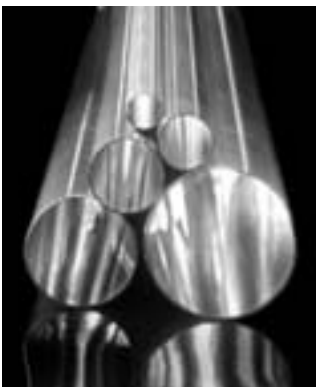

POLISHED ID/OD TUBING		
SIZE	NOMINAL WALL	316L PART NO.
1/2"	1.5mm	TOD-R50P
3/4"	1.5mm	TOD-R75P
1"	1.5mm	TOD-R100P
1 1/2"	1.5mm	TOD-R150P
2"	1.5mm	TOD-R200P
2 1/2"	1.5mm	TOD-R250P
3"	1.5mm	TOD-R300P
4"	2mm	TOD-R400P
6"	2mm	TOD-R600P
8"	2mm	TOD-R800P

Tubing usually sold in 6 metre / 20 foot lengths.



H

Permanently Attached Couplings - Holedall® System

The Holedall System & Accessories	240-244
Internal Expansion (IX) Couplings & Ferrules	245-246
Hygienic Stem & Ferrule.....	247-248
Permanent Petroleum Couplings.....	249-252
Pump Hose Couplings	253-254
External Swage (ES) Couplings & Ferrules	255-256
External Crimp (EC) Couplings & Ferrules	257-258
Hookie Hook Stem & Ferrules	259
Holedall® Swaging Machines	260
Holedall® Internal Expansion Machine Tooling.....	261
High Pressure & Custom Made Couplings	262
Holedall Swaged Rotary Drilling Hose Coupling System	263-264
Forged Steel Hammer Unions	265-266

H

**FOR A FULL RANGE OF HOSES
TO COMPLEMENT THESE FITTINGS SEE SECTION F**



Holedall® - Permanently Attached Coupling System



Based upon the already highly successful Holedall®/Mulconroy Coupling System, which has been manufactured and marketed by our parent company - Dixon Valve & Coupling since 1940 in the United States. This comprehensive range has been specifically designed and developed to service the needs of both industrial and the Offshore Oil & Gas markets.

Holedall couplings conform to all European specifications and quality requirements, including: EN1765 and EN14421.

IX Couplings are specified for use in Type Approved Hose Assemblies by Det Norsk Veritas, Lloyds Register of Shipping etc., and are in service with most of the World's major oil drilling companies on Offshore and hand rig applications.

The Holedall® Coupling System provides a safe and cost effective method of outstanding strength and durability of attaching couplings to hose. Ease of operation, flexibility and economy make the Holedall method an un-equalled hose assembly system.

With both Internal Expansion and External Swage Couplings, the Holedall system utilises a cold worked, draw type progressive swage method which gives a full 360° uninterrupted expansion or compression band around the hose, giving superb coupling retention and end load characteristics.

The Holedall range of External Crimp Couplings which includes an interlocking groove and collar offers an alternative safe and secure method of producing hose assemblies to 8" nominal bore.

Only quality assured, materials are used in the production of Holedall Couplings, with materials used for swaging having been selected to establish the proof/yield stress to ensure that brittle fracture does not occur. Certification in accordance with EN10204 3.1. is available with all couplings.

The Holedall system does not stop at couplings. We also manufacture and supply a range of machines for hose assembly including, Internal Expansion Machines, External Swaging Machines, Dual Swaging Machines, External Crimping Machines and Coupling Inserting Machines and Hydrostatic Test Pumps.

Definitions

- "Stem", Nipple, Tail is an externally serrated coupling which fits inside the bore of the hose.
- "Ferrule" is an internally serrated steel cylinder which fits over the outside of the hose or pipe and interlocks with the stem.

What's the difference?

Internal Expansion (IX)

Internal expansion or swaging, is the process by which the stem is internally expanded to compress the hose material against the serrated internal ferrule wall to provide retention. Internal expansion also provides full flow through the bore of the stem significantly reducing turbulence and the possibility of bacteria becoming trapped between the end of the stem and the hose. This is particularly important for food grade hose assemblies and CIP applications.

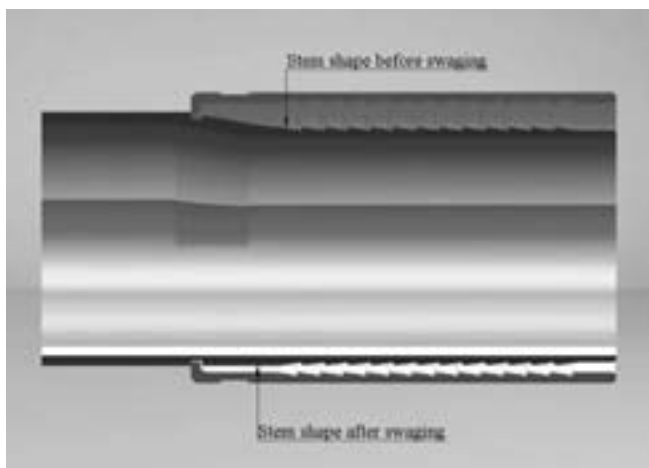

Internal expansion is achieved by pulling a hardened tool of the same size as the hose bore, called a dolly or plug down the inside of the stem in order to expand it. The compressive force exerted on the hose wall by the stem causes the hose material to flow into the serrated cavities of both stem and ferrule, providing a permanently attached secure mechanical bond.



H

External Swaging (ES)

External Swaging is the opposite process to internal expansion, in that it is the process of reducing the ferrule onto the hose outside diameter and subsequently compressing the hose material into the serrated cavities of both the stem and ferrule, providing a safe and secure method of attachment.

External swaging is achieved by pushing the hose and end coupling assembly through a hardened steel split-die.

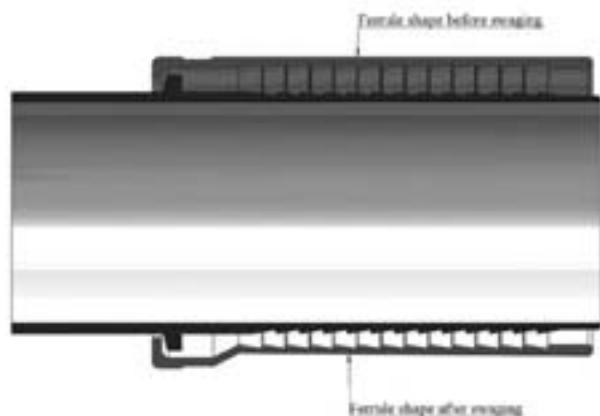

The internal diameter of the die is smaller than the external diameter of the ferrule. Similar in process to internal expansion, the external diameter of the ferrule is permanently reduced which results in compressive force exerted onto the hose wall causing it to flow into the serrated cavities of both stem and ferrule, providing a permanently attached secure mechanical bond.



Permanently Attached Couplings - Holedall® System

Dual Swaging (DS)

Dual swaging is mainly used to attach couplings to high pressure hose or hose with very thick wall section. This is accomplished by compressing both the stem and the ferrule onto the hose material in order to provide a secure method of attachment. Internal expansion and external swaging by themselves are perfectly adequate for low to medium pressure applications, however for higher pressure applications, it may be necessary to dual swage.

Dual swaging is effectively internal expansion and external swaging or crimping combined. The aim is to compress both stem and the ferrule onto the hose in order to provide the necessary grip. It is essential when dual swaging to compress both the inside and outside diameters of the hose by similar amounts in order to minimise any damage to the reinforcing layers. In some instances it may be necessary to skive the hose down to the wires/cables.

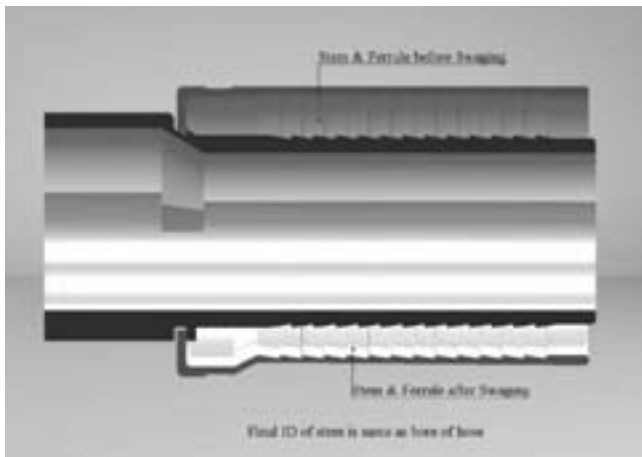

H

External Crimping (EC)

External crimping is a similar method of attaching couplings as external swage. All Holedall® External crimp couplings have an interlocking groove in which the ferrule is located/secured. External Crimp is the process of compressing the serrated ferrule onto the hose outside diameter and subsequently compressing the hose material into the serrated cavities of both the stem and ferrule, providing a safe and secure method of attachment.

Similar in principle to external swaging. The external diameter of the ferrule is permanently reduced radially by segmented Dies resulting in a compressive force being applied to the hose causing it to flow into the serrated cavities of both stem and ferrule thus providing a secure mechanical bond. At the same time, the retaining ring of the ferrule is secured in the groove of the stem.

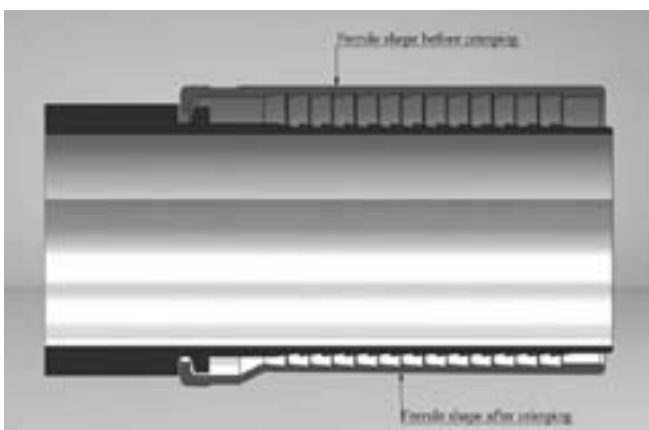

Coupling Inserter for Large Hose



PART NO.

2500HB0000

- highly portable
- inserts 4", 5", 6", 8", 10" and 12" couplings
- includes CI96AH pump (shown below)

Coupling Inserters



coupling inserter with hand pump

- for insertion of hose shanks into hose with a 2¾" to 7¼" OD

PART NO.	SIZE
CI96 CI96AH CI9311SML	Supplied with a 10,000 PSI hand pump and 5 ton ram Supplied with a 10,000 PSI air/hydraulic pump and 5 ton ram Small jaws for 1" to 3" OD hose



air/hydraulic foot pump

Hand Hydrotest Pump



- stainless steel piston, aluminum body
- designed for use in testing pipe lines, pressure tanks and pressure vessels
- uses efficient and long lasting check valves
- cylinder displacement: 1.37 cubic inches
- 0-1000 PSI pressure gauge, 10' pressure hose and quick disconnect coupler included
- piston: 7/8" with 2" stroke

PART NO.	INLET NPT	OUTLET NPT	WORKING PRESSURE PSI
HHTP	½"	½"	1000

Hydrostatic Test Pumps

A safe, cost effective pump to test hose before putting it into service.



- 1.3 GPM fill rate
- test pressure: 200 to 2000 PSI
- suction strainer keeps dirt out of pump
- high pressure test gauge
- 115v motor
- 2 ft. power cord
- easy to use, portable

ELECTRIC	
PART NO.	DESCRIPTION
ETP	Electric test pump

H



- 5.5 GPM fill rate
- test pressure: 0 to 1500 PSI
- stainless interior
- air gauge for quick, easy adjustment of maximum test pressure
- high pressure test gauge
- filter/regulator for clean, dry air to ensure long life of unit
- on - off valve for air input
- 15 ft. of hose included
- easy to use, portable
- Use of coalescing filter and water filter recommended for prolonged life.

PNEUMATIC	
PART NO.	DESCRIPTION
PTP	Pneumatic test pump

Holedall® IX Internal Expansion

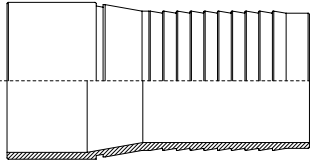

PLAIN END STEM FOR WELDING - NATURAL FINISH		
CARBON STEEL PART NO.	STAINLESS STEEL PART NO.	NOMINAL BORE*
HA0050	HA1050	2"
HA0037	HA1037	2 1/2"
HA0032	HA1032	3"
HA0029	HA1029	4"
HA0054	HA1054	5"
HA0058	HA1058	6"
HA0099	HA1099	8"
HA0369	-	10"
HA0370	-	12"

Plain End Stems are usually manufactured in Carbon Steel: ASTM A106 Grade A/B or API 5L Grade A/B, and Stainless Steel: BS970: 1983 Grade 316 S11. * Couplings are also available for metric sized hose bores.

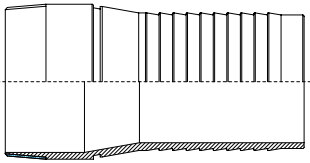

MALE THREAD STEM - YELLOW ZINC PLATED						
CARBON STEEL PART NO.S			STAINLESS STEEL PART NO.S			NOMINAL BORE*
BSP	BSPT	API/NPT	BSP	BSPT	API/NPT	
HA0051ZP	HA0051TZP	HA0052ZP	HA1051	HA1051T	HA1052	2"
HA0038ZP	HA0038TZP	HA0039ZP	HA1038	HA1038T	HA1039	2 1/2"
HA0033ZP	HA0033TZP	HA0034ZP	HA1033	HA1033T	HA1034	3"
HA0031ZP	HA0031TZP	HA0026ZP	HA1031	HA1031T	HA1026	4"
HA0055ZP	HA0055TZP	HA0056ZP	HA1055	HA1055T	HA1056	5"
HA0059ZP	HA0059TZP	HA0060ZP	HA1059	HA1059T	HA1060	6"
HA0144ZP	HA0144TZP	HA0145ZP	HA1144	HA1144T	HA1145	8"
-	HA0371TZP	-	-	-	-	10"
-	HA0372TZP	-	-	-	-	12"

Threaded End Stems are usually manufactured in Carbon Steel: ASTM A106 Grade A/B or API 5L Grade A/B, and Stainless Steel: BS970: 1983 Grade 316 S11. * Couplings are also available for metric sized hose bores.

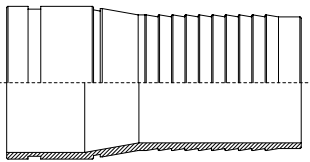

VICTAULIC GROOVE STEM - YELLOW ZINC PLATED		
CARBON STEEL PART NO.	STAINLESS STEEL PART NO.	NOMINAL BORE*
HA0053ZP	HA1053	2"
HA0040ZP	HA1040	2 1/2"
HA0035ZP	HA1035	3"
HA0030ZP	HA1030	4"
HA0057ZP	HA1057	5"
HA0061ZP	HA1061	6"
HA0148ZP	HA1148	8"

Victaulic Groove Stems are usually manufactured in Carbon Steel: ASTM A106 Grade A/B or API 5L Grade A/B, and Stainless Steel: BS970: 1983 Grade 316 S11. * Couplings are also available for metric sized hose bores.

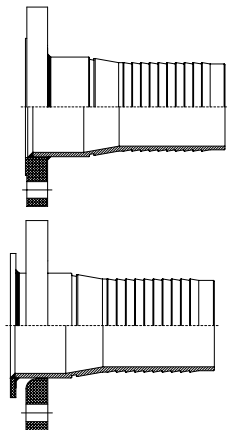

FLANGED STEM - FIXED & SWIVEL - YELLOW ZINC PLATED				
CARBON STEEL PART NO.S		STAINLESS STEEL PART NO.S		NOMINAL BORE*
FIXED	SWIVEL	FIXED	SWIVEL	
HA0134ZP	HA0150ZP	HA1134	HA1150	2"
HA0135ZP	HA0151ZP	HA1135	HA1151	2 1/2"
HA0136ZP	HA0152ZP	HA1136	HA1152	3"
HA0137ZP	HA0153ZP	HA1137	HA1153	4"
HA0138ZP	HA0154ZP	HA1138	HA1154	5"
HA0139ZP	HA0155ZP	HA1139	HA1155	6"
HA0140ZP	HA0156ZP	HA1140	HA1156	8"
HA0924ZP	HA0397ZP	-	-	10"
HA0925ZP	HA0926ZP	-	-	12"

Flanged Stems are usually manufactured in Carbon Steel: ASTM A106 Grade A/B or API 5L Grade A/B, and Stainless Steel: BS970:1983 Grade 316 S11. *Couplings are also available for metric sized hose bores

Permanently Attached Couplings - Holedall® System

Ferrules - Yellow Zinc

Ferrule Selection Chart (Standard 20 Bar Hose)

INTERNAL EXPANSION FERRULE SELECTION GUIDE												
PART NO. PREFIX WALL THK. (MM)	HOSE BORE SIZE (STANDARD INCH SIZING)											
	1IN	1.25IN	1.5IN	2IN	2.5IN	3IN	4IN	5IN	6IN	8IN	10IN	12IN
4.0	40.5-2.5	47-2.5										
4.5	41.5-2.5	48-2.5										
5.0	42.5-2.5	49-2.5	56-3									
5.5	43.5-2.5	50-2.5	57-3									
6.0	44.5-2.5	51-2.5	58-3	71-3	84-3	97-3						
6.5	45.5-2.5	52-2.5	59-3	72-3	85-3	98-3						
7.0	46.5-2.5	53-2.5	60-3	73-3	86-3	99-3	125-3	152-4				
7.5		54-2.5	61-3	74-3	87-3	100-3	126-3	153-4				
8.0		55-2.5	62-3	75-3	88-3	101-3	127-3	154-4				
8.5		56-2.5	63-3	76-3	89-3	102-3	128-3	155-4				
9.0		57-2.5	64-3	77-3	90-3	103-3	129-3	156-4	182-4.5			
9.5		58-2.5	65-3	78-3	91-3	104-3	130-3	157-4	183-4.5			
10.0		59-2.5	66-3	79-3	92-3	105-3	131-3	158-4	184-4.5	236-5		
10.5				80-3	93-3	106-3	132-3	159-4	185-4.5	237-5		
11.0				81-3	94-3	107-3	133-3	160-4	186-4.5	238-5		
11.5				82-3	94-3	108-3	134-3	161-4	187-4.5	239-5		
12.0				83-3	95-3	109-3	135-3	162-4	188-4.5	240-5		
12.5				84-3	96-3	110-3	136-3	163-4	189-4.5	241-5		
13.0							137-3	164-4	190-4.5	242-5	295-6	
13.5							138-3	165-4	191-4.5	243-5	296-6	
14.0							139-3	166-4	192-4.5	244-5	297-6	
14.5							140-3	167-4	193-4.5	245-5	298-6	349-6
15.0							141-3	168-4	194-4.5	246-5	299-6	350-6
15.5								169-4	195-4.5	247-5	300-6	351-6
16.0								170-4	196-4.5	248-5	301-6	352-6
16.5								171-4	197-4.5	249-5	302-6	353-6
17.0									198-4.5	250-5	303-6	354-6
17.5										251-5	304-6	355-6
18.0										252-5	305-6	356-6
18.5										253-5	306-6	357-6
19.0										254-5	307-6	358-6
19.5										255-5	308-6	359-6
20.0										256-5	309-6	360-6

H

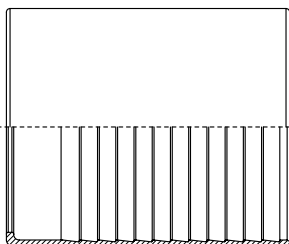

Carbon Steel Ferrules are supplied Yellow Zinc Plated and Passivated in accordance with BS1706:1990 or alternatively Powder Painted in accordance with the Oil & Gas UK Colour Coding Scheme which can be found on Page XX of this catalogue Please specify Ferrule Finish on your purchase

Order Stainless Steel Ferrules are supplied in Grade 304/304L and are natural finish.

Ferrule Coding example: 4" Hose x 10mm wall thickness, for conveying Base Oil. The prefix is HA0065 from table 2. The Ferrule Coding for a 10mm wall thickness hose is 131-3 from table 1. The colour coding is from the Oil & Gas UK Colour Coding Scheme which can be found on Page 259 of this catalogue = RED. The complete part number is HA0065-131-3RED

CARBON STEEL	
PART NO. PREFIX	SIZE
HA0350	1.0in
HA0789	1.25in
HA0332	1.5in
HA0062	2.0in
HA0063	2.5in
HA0064	3.0in
HA0065	4.0in
HA0066	5.0in
HA0167	6.0in
HA0187	8.0in
HA0367	10.0in
HA0368	12.0in

STAINLESS STEEL	
PART NO. PREFIX	SIZE
HA1350	1.0in
HA1789	1.25in
HA1332	1.5in
HA1062	2.0in
HA1063	2.5in
HA1064	3.0in
HA1065	4.0in
HA1066	5.0in
HA1067	6.0in
HA1187	8.0in
HA1367	10.0in
HA1368	12.0in

Holedall® Hygienic Stem & Ferrule

For the food, brewing, chemical and pharmaceutical industry.
Stems are manufactured from AISI 316L Stainless Steel.

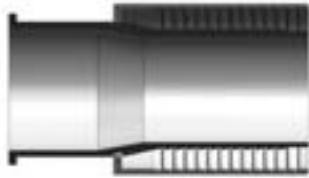

BS 4825: PART 5: TYPE RJT		
INTERNAL EXPANSION STEM PART NO.		NOMINAL BORE / DN*
MALE	FEMALE	
-	HA0229	1" / 25
-	HA0231	2" / 50
-	HA0232	2 1/2" / 65

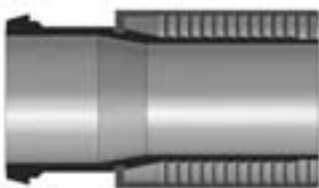

DIN 11887 / DIN 11851		
INTERNAL EXPANSION STEM PART NO.		NOMINAL BORE / DN*
MALE	FEMALE	
HA0274	HA0244	1" / 25
HA0275	HA0245	1 1/2" / 40
HA0276	HA0246	2" / 50
HA0277	HA0247	2 1/2" / 65
HA0278	HA0248	3" / 80
HA0299	HA0300	4" / 100

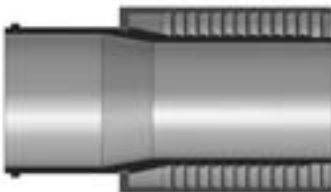

BS 4825: PART 4: TYPE IDF		
INTERNAL EXPANSION STEM PART NO.		NOMINAL BORE / DN*
MALE	FEMALE	
-	HA0650	2 1/2" / 65
-	HA0652	4" / 100

H

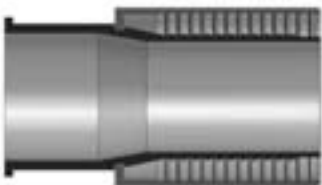

SMS		
INTERNAL EXPANSION STEM PART NO.		NOMINAL BORE / DN*
MALE	FEMALE	
-	HA0608	1 1/2" / 40
-	HA0609	2" / 50
-	HA0610	2 1/2" / 65
-	HA0611	3" / 80
-	HA0612	4" / 80



BS 4825: PART 3: CLAMP TYPE		
INTERNAL EXPANSION STEM PART NO.	NOMINAL BORE / DN*	
HA0665	1" / 25	
HA0666	1 1/2" / 40	
HA0667	2" / 50	
HA0668	2 1/2" / 65	
HA0669	3" / 80	
HA0670	4" / 80	

* Couplings are also available for metric sized hose bores.

Permanently Attached Couplings - Holedall® System



INTERNAL EXPANSION STAINLESS STEEL HYGIENIC FERRULES

PART NO. INTERNAL	NOMINAL BORE / DN	HOSE RANGE	
		FROM	TO
HA0259-44-3	1" / 25	35.7	36.5
HA0259-45-3	1" / 25	36.9	37.7
HA0259-46-3	1" / 25	38.1	38.9
HA0259-48-3	1" / 25	39.3	40.1
HA0259-49-3	1" / 25	40.5	41.3
HA0260-57-3	1 1/2" / 40	48.4	49.6
HA0260-58-3	1 1/2" / 40	50	51.2
HA0260-60-3	1 1/2" / 40	51.6	52.8
HA0260-62-3	1 1/2" / 40	53.2	54.4
HA0261-71-3	2" / 50	62.7	63.9
HA0261-73-3	2" / 50	64.3	65.5
HA0261-74-3	2" / 50	65.9	67.1
HA0261-76-3	2" / 50	67.4	68.7
HA0262-85-3	2 1/2" / 65	76.1	78.1
HA0263-100-3	3" / 80	91.7	92.9
HA0263-101-3	3" / 80	92.1	93.3
HA0263-102-3	3" / 80	93.6	94.9
HA0263-104-3	3" / 80	95.2	96.5
HA0263-105-3	3" / 80	96.8	98.0
HA0263-107-3	3" / 80	98.4	99.6
HA0303-127-3	4" / 100	117.5	118.7
HA0303-129-3	4" / 100	119.0	120.3
HA0303-130-3	4" / 100	120.6	121.9
HA0303-132-3	4" / 100	122.2	123.5
HA0303-134-3	4" / 100	123.8	125.0

Ferrules are manufactured from grade 304 S15 (1.4301) When ordering Ferrules, please state hose dimensions.

H

INTERNAL EXPANSION HYGIENIC ENGINEERING POLYMER FERRULES



Please note: These fittings are available to suit RJT, IDF, SMS, DIN. Please advise your requirement.

PART NO.	SIZE	HOSE OD RANGE (MM)	
		TO	FROM
HA0259-46-4BLU	1"	35.7	36.5
HA0259-47-4BLU	1"	36.9	37.7
HA0259-48-4BLU	1"	38.1	38.9
HA0259-50-4BLU	1"	39.3	40.1
HA0259-51-4BLU	1"	40.5	41.3
HA0260-59-4BLU	1 1/2"	48.4	49.6
HA0260-60-4BLU	1 1/2"	50	51.2
HA0260-62-4BLU	1 1/2"	51.6	52.8
HA0260-64-4BLU	1 1/2"	53.2	54.4
HA0261-73-4BLU	2"	62.7	63.9
HA0261-75-4BLU	2"	64.3	65.5
HA0261-76-4BLU	2"	65.9	67.1
HA0261-78-4BLU	2"	67.4	68.7
HA0262-89-5BLU	2 1/2"	76.1	78.1
HA0263-104-5BLU	3"	91.7	92.9
HA0263-105-5BLU	3"	92.1	93.3
HA0263-106-5BLU	3"	93.6	94.9
HA0263-108-5BLU	3"	95.2	96.5
HA0263-109-5BLU	3"	96.8	98
HA0263-111-5BLU	3"	98.4	99.6

Holedall Engineering Polymer Ferrules are also available in sizes 1" thru 3" for Industrial Hose applications, with a maximum working pressure of 20 Bar/300 psi.

Internally Expanded Permanent Couplings - Scovill Style

Brass internally expanded permanent couplings are recommended for discharge and suction service. Commonly used in the transfer of fuel to homes, airplanes, ships, etc. The working pressure of the 520-H fitting varies with the size of the fitting, the size and construction of the hose and the media being conveyed. Dixon Holedall stems and ferrules are specifically designed to be used together as a coupling system.

Both the male and female have octagonal facets for tightening with a wrench. The female in 1½" and larger sizes has lugs for tightening. The stem is expanded to nominal ID of hose for a rigid, uniform, full-flow area.



- Male and female stems are machined from bar stock or solid brass forgings; ferrules are available in brass and stainless steel.
- Couplings are compact, light and streamlined to eliminate catching on curbs and shrubs.
- The H520 fittings are designed for internal expansion only
- Couplings are pre-lubricated for assembly.
- Hand and electrically operated installation equipment is available. Consult factory for pricing and availability.

INTERNALLY EXPANDED PERMANENT COUPLINGS - SCOVILL STYLE - BRASS

MALE NPT PART NO.	MALE NST PART NO.	FEMALE NPSH PART NO.	FEMALE NST PART NO.	VICTAULIC GROOVE PART NO.	HOSE ID
H5192	-	H5191-BU	-	-	¾"
H5212-A	H5212NST	H5211-A-BU	H5211NST	G5212	1"
H5222-A	-	H5221-A-BU	-	-	1-1¼"
H5272 ¹	-	H5271-BU ¹	-	-	1-1⅜"
H5232-A	H5232NST	H5231-A-BU	H5231NST ²	G5232	1-1½"
H5242	-	H5241-BU	-	G5242	2"
H5252	-	H5251 ³	-	-	2-2½"
H5262	-	H5261 ³	-	-	3"

1. 1⅜" stem has 1½" thread

2. 1½" NST requires special adapter, part # H5231NSTADT

3. 2½" and 3" parts have female NPSM thread

Note: The fittings on this page are intended for fuel delivery service.

Permanently Attached Couplings - Holedall® System

520-H Ferrules

A wide range of 520-H ferrules permits a perfect assembly of a coupling to a corresponding size of hose within commercial tolerances regardless of wall thickness. Eliminates need for large stock of coupling bodies. Consult Dixon for other hose OD's



520-H FERRULES - BRASS

PART NO.	HOSE ID	HOSE OD		PART NO.	HOSE ID	HOSE OD		PART NO.	HOSE ID	HOSE OD	
		FROM	TO			FROM	TO			FROM	TO
R75AAS	3/4"	28.58	28.58	R1375BS	1 3/8"	44.05	45.24	R2AAS	2"	61.52	62.71
R75AS	3/4"	30.16	30.16	R1375CS	1 3/8"	45.64	46.83	R2AS	2"	63.10	64.29
R75BS	3/4"	31.35	31.35	R1375DS	1 3/8"	47.23	48.42	R2BS	2"	64.69	65.88
R75CS	3/4"	32.54	32.54	R1375ES	1 3/8"	48.82	50.01	R2CS	2"	66.28	67.47
R1AAAS-A	1"	34.93	35.72	R15AAAS-A	1 1/2"	46.83	48.02	R2DS	2"	67.87	69.06
R1AAS-A	1"	36.12	36.91	R15AAS-A	1 1/2"	48.42	50.01	R2ES	2"	69.45	70.64
R1AS-A	1"	37.31	38.10	R15AS-A	1 1/2"	50.40	51.59	R2FS	2"	71.04	72.23
R1BS-A	1"	38.50	39.29	R15BS-A	1 1/2"	51.99	53.18	R25AS	2 1/2"	75.41	76.60
R1CS-A	1"	39.69	40.48	R15CS-A	1 1/2"	53.58	55.17	R25BS	2 1/2"	76.99	78.58
R1DS-A	1"	40.88	41.67	R15DS-A	1 1/2"	55.56	56.36	R25CS	2 1/2"	78.98	80.57
R1ES-A	1"	42.07	42.86	R15ES-A	1 1/2"	56.75	58.34	R25DS	2 1/2"	80.96	82.55
R125AAS-A	1 1/4"	40.88	42.07	R15FS	1 1/2"	58.74	60.33	R25ES	2 1/2"	82.95	84.53
R125AS-A	1 1/4"	42.47	43.66	R15GS	1 1/2"	60.72	61.91	R25FS	2 1/2"	84.93	86.52
R125BS-A	1 1/4"	44.05	45.24					R3AAAS	3"	88.11	89.69
R125CS-A	1 1/4"	45.64	46.83					R3AAS	3"	90.09	91.68
R125DS-A	1 1/4"	47.23	48.42					R3AS	3"	92.08	94.06
ZTTR125ES	1 1/4"	48.82	50.01					R3BS	3"	94.46	96.04
								R3CS	3"	96.44	97.63

H

API Certified Permanently Attached Petroleum Couplings

The following fittings have been tested and are compliant with API 1529 6th edition.
Coupling procedures, ferrule recommendations and API test data are available upon request.



520-H SERIES MALE THREAD			
BRASS PART NO.	ALUMINIUM PART NO.	HOSE SIZE	THREAD TYPE
H5212-A	-	1"	NPT
H5222-A	-	1¼"	NPT
H5232-A	-	1½"	NPT
H5242L-A	A5242L-A ¹	2"	NPT
H5252L-A	A5252L-A ¹	2½"	NPT
H5262L-A	A5262L-A ¹	3"	NPT
H5282L-A	-	4"	NPT

¹ requires a special thrust plate

2" 25000HTL24 2½" 25000HTL25 3" 25000HTL26



520-H SERIES FEMALE THREAD		
BRASS PART NO.	HOSE SIZE	THREAD TYPE
H5211-A-BU	1"	NPSH
H5221-A-BU	1¼"	NPSH
H5231-A-BU	1½"	NPSH
H5241L-A-BU	2"	NPSH
H5251L-A-BU	2½"	NPSM
H5261L-A-BU	3"	NPSM
H5281L-A-BU	4"	NPSM

H

API 520-H Series Ferrules



API 520-H SERIES FERRULES

BRASS PART NO.	HOSE ID	HOSE OD		304 STAINLESS STEEL PART NO.	ALUMINIUM PART NO.	HOSE ID	HOSE OD	
		FROM	TO				FROM	TO
R1AAAS-A	1"	34.93	35.72	R2ASS-A	R2AAL-A	2"	63.10	64.29
R1AAS-A	1"	36.12	36.91	R2BSS-A	R2BAL-A	2"	64.69	65.88
R1AS-A	1"	37.31	38.10	R2CSS-A	R2CAL-A	2"	66.28	67.47
R1BS-A	1"	38.50	39.29	R2DSS-A	R2DAL-A	2"	67.87	69.06
R1CS-A	1"	39.69	40.48	R2ESS-A	R2EAL-A	2"	69.45	70.64
R1DS-A	1"	40.88	41.67	R25ASS-A	R25AAL-A	2 1/2"	75.41	76.60
R1ES-A	1"	42.07	42.86	R25BSS-A	R25BAL-A	2 1/2"	76.99	78.58
R125AAS-A	1 1/4"	40.88	42.07	R25CSS-A	R25CAL-A	2 1/2"	78.98	80.57
R125AS-A	1 1/4"	42.47	43.66	R25DSS-A	R25DAL-A	2 1/2"	76.99	82.55
R125BS-A	1 1/4"	44.05	45.24	R25ESS-A	R25EAL-A	2 1/2"	82.95	84.53
R125CS-A	1 1/4"	45.64	46.83	R3AASS-A	R3AAAL-A	3"	90.09	91.68
R125DS-A	1 1/4"	47.23	48.42	R3ASS-A	R3AAL-A	3"	92.08	94.06
R125ES-A	1 1/4"	48.82	50.01	R3BSS-A	R3BAL-A	3"	94.46	96.04
R15AAAS-A	1 1/2"	46.83	48.02	R3CSS-A	R3CAL-A	3"	96.44	97.63
R15AAS-A	1 1/2"	48.42	50.01	R3DSS-A	R3DAL-A	3"	98.03	99.62
R15AS-A	1 1/2"	50.40	51.59	R4ESS-A	-	4"	119.86	120.65
R15BS-A	1 1/2"	51.99	53.18	R4FSS-A	-	4"	121.05	121.84
R15CS-A	1 1/2"	53.58	55.17	R4GSS-A	-	4"	122.24	123.03
R15DS-A	1 1/2"	55.56	56.36	R4HSS-A	-	4"	123.43	124.22
R15ES-A	1 1/2"	56.75	58.34	R4KSS-A	-	4"	124.62	125.02
				R4LSS-A	-	4"	125.41	126.21
				R4MSS-A	-	4"	126.60	127.00

H

Replacement Washers



REPLACEMENT WASHERS

PART NO.	SIZE
H5071-BU	3/4"
H5072-BU	1"
H5073-BU	1 1/4"
H5074-BU	1 1/2"
H5075-BU	2"
H5076-BU	2 1/2"
H5077-BU	3"
H5078-BU	4"

Permanent Couplings for Pump Hose

The most economical and trouble-free couplings for gas pump hose. Serrations on the stem become imbedded in the hose eliminating wicking and leakage. The shell extends beyond the stem to prevent cutting of interior walls. Tapered ends of stem and shell protect hose when flexed.

- Couplings provide tamper-proof static connection which cannot be broken without completely damaging coupling and hose
- internal expansion of stem to nominal ID of hose provides full flow
- Broad, firm grip of coupling extends hose life by making it possible for hose to withstand more flexings
- Hand and electrically operated installation equipment are available
- Caution: Reattach static wire if required

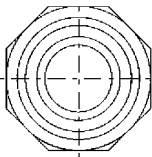
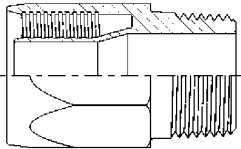
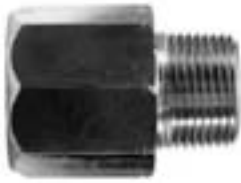

PERMANENT COUPLINGS FOR PUMP HOSE - CHROME BRASS PLATED			
PART NO.	HOSE ID	MALE NPT	HOSE OD
H5741	5/8"	3/4"	25.40
H5742	5/8"	3/4"	26.19
H5751	3/4"	3/4"	28.97
H5752	3/4"	3/4"	29.77
H5753	3/4"	3/4"	30.56
H5754	3/4"	3/4"	30.96
H5755 ¹	3/4"	3/4"	32.15
H5771	1"	1"	35.32
H5772	1"	1"	36.91
H5773	1"	1"	38.10
H5774	1"	1"	39.69

1. thrust plate required 25000HTL15

HB Coupling Expander Machine



PART NO.
2500HB0000

- hand operated, pull-through type expander
- for use in a fixed location for small production runs or as a portable repair type expander
- attaches sizes 3/4" through 2" of the 520-H Series couplings, and all sizes of 570-H and 580-H Series couplings
- expander tooling sold separately

Dubl-Grip® Re-attachable Couplings for Curb Pump Hose

Two-piece re-attachable coupling made of chrome-plated brass for pump hose. Streamlined design prevents damage to hose and fits smartly on new pump equipment. Wide, flat surfaces of body threads protect inside of hose from breaking. Tapered surfaces of sleeve and body cradle hose, prevent one-point strain from flexing. Hose is gripped on its full circumference in two places, insuring a rigid leakproof connection.

- couplings have standard male NPT threads
- worn portion of hose can be removed and Dubl-Grip® can be reapplied
- easy assembly:
Hose is held in position by sleeve as body is threaded home
Only a wrench is required to assemble the Dubl-Grip®
- Caution: Reattach static wire if required

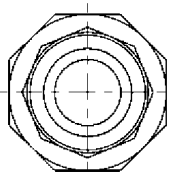
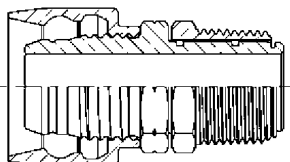

H

H-600 SERIES DUBL-GRIP® SWIVEL REATTACHABLES - CHROME PLATED BRASS

PART NO.	HOSE ID	MALE NPT	HOSE OD
H600 ¹	5/8"	3/4"	26.99
H601 ¹	5/8"	3/4"	25.40
H602 ¹	5/8"	3/4"	26.19
H603	3/4"	3/4"	28.58
H604	3/4"	3/4"	30.56
H605	3/4"	3/4"	31.75
H609 ²	1"	1"	34.93
H610 ²	1"	1"	36.51
H611 ²	1"	1"	38.10

1. items will be discontinued when stock is depleted

2. octagonal shape

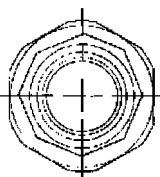
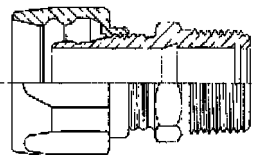

DUBL-GRIP® REATTACHABLES - CHROME PLATED BRASS

PART NO.	HOSE ID	MALE NPT	HOSE OD
850212	5/8"	3/4"	25.40
850213	5/8"	3/4"	26.19
850214	5/8"	3/4"	26.99
850451	3/4"	3/4"	28.58
850455	3/4"	3/4"	30.56
850453	3/4"	3/4"	31.75
850841 ¹	1"	1"	34.93
850801 ¹	1"	1"	36.51
850811 ¹	1"	1"	38.10

1. octagonal shape

Holedall® ES External Swage Couplings

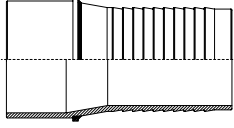

PLAIN END STEM FOR WELDING - NATURAL FINISH		
CARBON STEEL PART NO.	STAINLESS STEEL PART NO.	NOMINAL BORE*
HA0074	HA1074	2"
HA0075	HA1075	2 1/2"
HA0076	HA1076	3"
HA0077	HA1077	4"
HA0078	HA1078	5"
HA0079	HA1079	6"
HA0100	HA1100	8"

Plain End Stems are usually manufactured in Carbon Steel: ASTM A106 Grade A/B or API 5L Grade A/B, and Stainless Steel: BS970: 1983 Grade 316 S11.

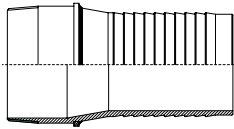

MALE THREAD STEM - YELLOW ZINC PLATED						
CARBON STEEL PART NO.S			STAINLESS STEEL PART NO.S			NOMINAL BORE*
BSP	BSPT	API/NPT	BSP	BSPT	API/NPT	
HA0081ZP	HA0081TZP	HA0082ZP	HA1081	HA1081T	HA1082	2"
HA0084ZP	HA0084TZP	HA0085ZP	HA1084	HA1084T	HA1085	2 1/2"
HA0087ZP	HA0087TZP	HA0088ZP	HA1087	HA1087T	HA1088	3"
HA0090ZP	HA0090TZP	HA0091ZP	HA1090	HA1090T	HA1091	4"
HA0093ZP	HA0093TZP	HA0094ZP	HA1093	HA1093T	HA1094	5"
HA0096ZP	HA0096TZP	HA0097ZP	HA1096	HA1096T	HA1097	6"
HA0146ZP	HA0146TZP	HA0147ZP	HA1146	HA1146T	HA1147	8"

Threaded End Stems are usually manufactured in Carbon Steel: ASTM A106 Grade A/B or API 5L Grade A/B, and Stainless Steel: BS970: 1983 Grade 316 S11.

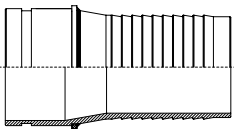

VICTAULIC GROOVE STEM - YELLOW ZINC PLATED		
CARBON STEEL PART NO.	STAINLESS STEEL PART NO.	NOMINAL BORE*
HA0083ZP	HA1083	2"
HA0086ZP	HA1086	2 1/2"
HA0089ZP	HA1089	3"
HA0092ZP	HA1092	4"
HA0095ZP	HA1095	5"
HA0098ZP	HA1098	6"
HA0149ZP	HA1149	8"

Victaulic Groove Stems are usually manufactured in Carbon Steel: ASTM A106 Grade A/B or API 5L Grade A/B, and Stainless Steel: BS970: 1983 Grade 316 S11.

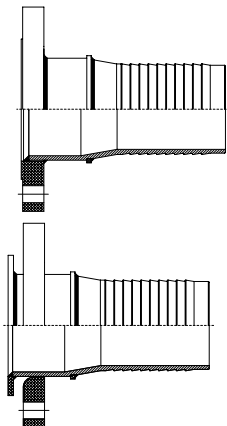

FLANGED STEM - FIXED & SWIVEL - YELLOW ZINC PLATED				
CARBON STEEL PART NO.S		STAINLESS STEEL PART NO.S		NOMINAL BORE*
FIXED	SWIVEL	FIXED	SWIVEL	
HA0172ZP	HA0157ZP	HA1172	HA1157	2"
HA0173ZP	HA0158ZP	HA1173	HA1158	2 1/2"
HA0174ZP	HA0159ZP	HA1174	HA1159	3"
HA0175ZP	HA0160ZP	HA1175	HA1160	4"
HA0176ZP	HA0161ZP	HA1176	HA1161	5"
HA0177ZP	HA0162ZP	HA1177	HA1162	6"
HA0178ZP	HA0163ZP	HA1178	HA1163	8"

* Couplings are also available for metric sized hose bores

Permanently Attached Couplings - Holedall® System

Ferrules - Yellow Zinc Plated.

Ferrule Selection Chart (Standard 20 Bar Hose)

EXTERNAL SWAGE FERRULE SELECTION GUIDE										
PART NO. PREFIX WALL THK. (MM)	HOSE BORE SIZE (STANDARD INCH SIZING)									
	1IN	1.25IN	1.5IN	2IN	2.5IN	3IN	4IN	5IN	6IN	8IN
4.0										
4.5										
5.0										
5.5										
6.0	44.5-2.5	51-2.5	58-3	71-3	84-3	97-3				
6.5	45.5-2.5	52-2.5	59-3	72-3	85-3	98-3				
7.0	46.5-2.5	53-2.5	60-3	73-3	86-3	99-3	125-3	152-4		
7.5		54-2.5	61-3	74-3	87-3	100-3	126-3	153-4		
8.0		55-2.5	62-3	75-3	88-3	101-3	127-3	154-4		
8.5		56-2.5	63-3	76-3	89-3	102-3	128-3	155-4		
9.0		57-2.5	64-3	77-3	90-3	103-3	129-3	156-4	182-4.5	
9.5		58-2.5	65-3	78-3	91-3	104-3	130-3	157-4	183-4.5	
10.0		59-2.5	66-3	79-3	92-3	105-3	131-3	158-4	184-4.5	236-5
10.5				80-3	93-3	106-3	132-3	159-4	185-4.5	237-5
11.0				81-3	94-3	107-3	133-3	160-4	186-4.5	238-5
11.5				82-3	94-3	108-3	134-3	161-4	187-4.5	239-5
12.0				83-3	95-3	109-3	135-3	162-4	188-4.5	240-5
12.5				84-3	96-3	110-3	136-3	163-4	189-4.5	241-5
13.0							137-3	164-4	190-4.5	242-5
13.5							138-3	165-4	191-4.5	243-5
14.0							139-3	166-4	192-4.5	244-5
14.5							140-3	167-4	193-4.5	245-5
15.0							141-3	168-4	194-4.5	246-5
15.5								169-4	195-4.5	247-5
16.0								170-4	196-4.5	248-5
16.5								171-4	197-4.5	249-5
17.0									198-4.5	250-5
17.5										251-5
18.0										252-5
18.5										253-5
19.0										254-5
19.5										255-5
20.0										256-5

H

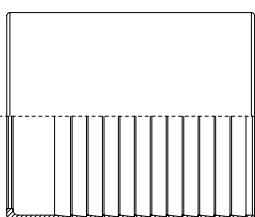

Carbon Steel Ferrules are supplied Yellow Zinc Plated and Passivated in accordance with BS1706:1990 or alternatively All Ferrule Part Numbers end in ZP Stainless Steel Ferrules are supplied in Grade 304/304L and are natural finish.

Ferrule Coding example:

4" Hose x 10mm wall thickness. The prefix is HA0071 from the CARBON STEEL' table. The Ferrule Coding for a 10mm wall thickness hose is 131-3 from the table above. The complete part number is HA0072-131-3ZP.

CARBON STEEL	
PART NO. PREFIX	SIZE
HA0068	2.0in
HA0069	2.5in
HA0070	3.0in
HA0071	4.0in
HA0072	5.0in
HA0073	6.0in
HA0188	8.0in

STAINLESS STEEL	
PART NO. PREFIX	SIZE
HA1068	2.0in
HA1069	2.5in
HA1070	3.0in
HA1071	4.0in
HA1072	5.0in
HA1073	6.0in
HA1188	8.0in



Holedall® EC External Crimp Couplings

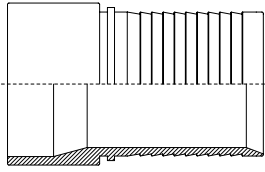

PLAIN END STEM FOR WELDING - NATURAL FINISH		
CARBON STEEL PART NO.	STAINLESS STEEL PART NO.	NOMINAL BORE*
HA0101	HA1101	3/4"
HA0102	HA1102	1"
HA0103	HA1103	1 1/4"
HA0104	HA1104	1 1/2"
HA0105	HA1105	2"
HA0106	HA1106	2 1/2"
HA0107	HA1107	3"
HA0108	HA1108	4"

Plain End Stems are usually manufactured in Carbon Steel: ASTM A106 Grade A/B or API 5L Grade A/B, and Stainless Steel: BS970: 1983 Grade 316 S11.

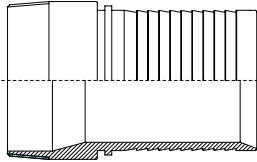

MALE THREAD STEM - YELLOW ZINC PLATED						
CARBON STEEL PART NO.S			STAINLESS STEEL PART NO.S			NOMINAL BORE*
BSP	BSPT	API/NPT	BSP	BSPT	API/NPT	
HA0109ZP	HA0109TZP	HA0117ZP	HA1109	HA1109T	HA1117	3/4"
HA0110ZP	HA0110TZP	HA0118ZP	HA1110	HA1110T	HA1118	1"
HA0111ZP	HA0111TZP	HA0119ZP	HA1111	HA1111T	HA1119	1 1/4"
HA0112ZP	HA0112TZP	HA0120ZP	HA1112	HA1112T	HA1120	1 1/2"
HA0113ZP	HA0113TZP	HA0121ZP	HA1113	HA1113T	HA1121	2"
HA0114ZP	HA0114TZP	HA0122ZP	HA1114	HA1114T	HA1122	2 1/2"
HA0116ZP	HA0115TZP	HA0123ZP	HA1115	HA1115T	HA1123	3"
HA0116ZP	HA0116TZP	HA0124ZP	HA1116	HA1116T	HA1124	4"

Threaded End Stems are usually manufactured in Carbon Steel: ASTM A106 Grade A/B or API 5L Grade A/B, and Stainless Steel: BS970: 1983 Grade 316 S11.

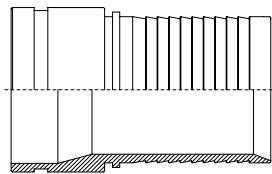

VICTAULIC GROOVE STEM - YELLOW ZINC PLATED		
CARBON STEEL PART NO.	STAINLESS STEEL PART NO.	NOMINAL BORE*
HA0125ZP	HA1125	3/4"
HA0126ZP	HA1126	1"
HA0127ZP	HA1127	1 1/4"
HA0128ZP	HA1128	1 1/2"
HA0129ZP	HA1129	2"
HA0130ZP	HA1130	2 1/2"
HA0131ZP	HA1131	3"
HA0132ZP	HA1132	4"

Victaulic Groove Stems are usually manufactured in Carbon Steel: ASTM A106 Grade A/B or API 5L Grade A/B, and Stainless Steel: BS970: 1983 Grade 316 S11.

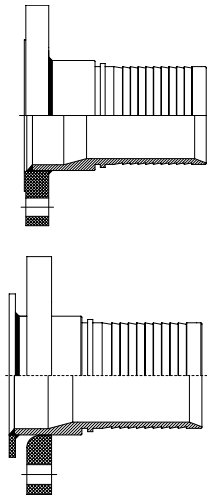

FLANGED STEM - FIXED & SWIVEL - YELLOW ZINC PLATED				
CARBON STEEL PART NO.S		STAINLESS STEEL PART NO.S		NOMINAL BORE*
FIXED	SWIVEL	FIXED	SWIVEL	
HA0179ZP	HA0164ZP	HA1179	HA1164	3/4"
HA0180ZP	HA0165ZP	HA1180	HA1165	1"
HA0181ZP	HA0166ZP	HA1181	HA1166	1 1/4"
HA0182ZP	HA0167ZP	HA1182	HA1167	1 1/2"
HA0183ZP	HA0168ZP	HA1183	HA1168	2"
HA0184ZP	HA0169ZP	HA1184	HA1169	2 1/2"
HA0185ZP	HA0170ZP	HA1185	HA1170	3"
HA0186ZP	HA0171ZP	HA1186	HA1171	4"

Flanged Stems are usually manufactured in Carbon Steel: ASTM A106 Grade A/B or API 5L Grade A/B, and Stainless Steel: BS970:1983 Grade 316 S11. Flange materials:- Carbon Steel - ASTM A105N; Stainless Steel - ASTM A182 Grade 316L. Both fixed (Slip-on-Weld) and Loose (Swivel) Flanged Stems are available with Flanges in accordance with ASME/ANSI B16.5 class 150/300 lb, BS4504 PN10/16, BS10 Tables D-H. Please specify Flange type and Flange Facing with Order.

For information regarding Ferrules, please refer to page 258.

*Couplings are also available for metric sized hose bores

Ferrules - Yellow Zinc Plated.

Ferrule Selection Chart (Standard 20 Bar Hose)

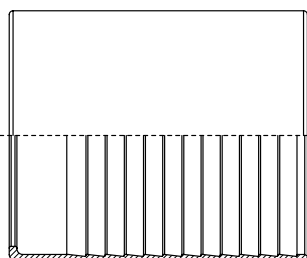

EXTERNAL CRIMP FERRULE SELECTION GUIDE

PART NO. PREFIX WALL THK. (MM)	HOSE BORE SIZE (STANDARD INCH SIZING)								
	1IN	1.25IN	1.50IN	2IN	2.50IN	3IN	4IN	5IN	6IN
4.0	40.5-2.5	47-2.5							
4.5	41.5-2.5	48-2.5							
5.0	42.5-2.5	49-2.5	56-3						
5.5	43.5-2.5	50-2.5	57-3						
6.0	44.5-2.5	51-2.5	58-3	71-3	84-3	97-3			
6.5	45.5-2.5	52-2.5	59-3	72-3	85-3	98-3			
7.0	46.5-2.5	53-2.5	60-3	73-3	86-3	99-3	125-3	152-4	
7.5		54-2.5	61-3	74-3	87-3	100-3	126-3	153-4	
8.0		55-2.5	62-3	75-3	88-3	101-3	127-3	154-4	
8.5		56-2.5	63-3	76-3	89-3	102-3	128-3	155-4	
9.0		57-2.5	64-3	77-3	90-3	103-3	129-3	156-4	182-4.5
9.5		58-2.5	65-3	78-3	91-3	104-3	130-3	157-4	183-4.5
10.0		59-2.5	66-3	79-3	92-3	105-3	131-3	158-4	184-4.5
10.5				80-3	93-3	106-3	132-3	159-4	185-4.5
11.0				81-3	94-3	107-3	133-3	160-4	186-4.5
11.5				82-3	94-3	108-3	134-3	161-4	187-4.5
12.0				83-3	95-3	109-3	135-3	162-4	188-4.5
12.5				84-3	96-3	110-3	136-3	163-4	189-4.5
13.0							137-3	164-4	190-4.5
13.5							138-3	165-4	191-4.5
14.0							139-3	166-4	192-4.5
14.5							140-3	167-4	193-4.5
15.0							141-3	168-4	194-4.5
15.5								169-4	195-4.5
16.0								170-4	196-4.5
16.5								171-4	197-4.5
17.0									198-4.5

Carbon Steel Ferrules are supplied Yellow Zinc Plated and Passivated in accordance with BS1706:1990 with the part number ending in ZP Stainless Steel Ferrules are supplied in Grade 304/304L and are natural finish.

Ferrule Coding example:

4" Hose x 10mm wall thickness. The prefix is HA0196 from 'CARBON STEEL' table. The Ferrule Coding for a 10mm wall thickness hose is 131-3 from the table above. The colour coding is from Oil & Gas UK Colour Coding Scheme which can be found on Page 259 of this catalogue = Red. The complete part number is HA0196-131-3ZP

CARBON STEEL

PART NO. PREFIX	SIZE
HA0190	1.0in
HA0191	1.25in
HA0192	1.5in
HA0193	2.0in
HA0194	2.5in
HA0195	3.0in
HA0196	4.0in
HA0417	5.0in
HA0418	6.0in

STAINLESS STEEL

PART NO. PREFIX	SIZE
HA1190	1.0in
HA1191	1.25in
HA1192	1.5in
HA1193	2.0in
HA1194	2.5in
HA1195	3.0in
HA1196	4.0in
HA1417	5.0in
HA1418	6.0in

Holedall® Hookie – Hook Stem & Ferrules

Hookie – Hook Stems & Ferrules are predominantly used for Bulk Loading/Rig Supply Hose operations on Offshore applications.

Stems are supplied Yellow Zinc Plated in accordance with BS1706: 1990 as standard, with threads to API Standard 5B: 1988. (NPT)

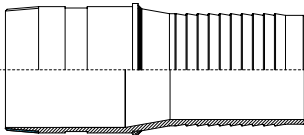
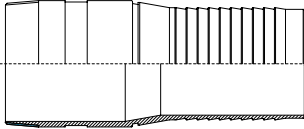

HOOKIE HOOK STEM		
INTERNAL EXPANSION STEM CARBON STEEL - PART NO.	EXTERNAL SWAGE STEM CARBON STEEL - PART NO.	NOMINAL BORE / DN
HA0141ZP	HA0197ZP	3" / 80
HA0142ZP	HA0198ZP	4" / 100
HA0143ZP	HA0199ZP	5" / 125

Internal Swage Ferrules can be supplied in either, natural, Yellow Zinc Plated or Powder Coat Painted finishes in accordance with Oil & Gas UK colour coding scheme or to suit specific requirements.

Ferrule Colour Coding

FERRULE COLOUR CODING	
FERRULE COLOUR CODE	HOSE APPLICATION
Yellow	Dry Cement
Orange	Dry Baryte
Blue	Potable Water
Brown	Diesel Oil / Fuel
Red	Base Oil / Brine
Green	Drill Water
Black	Oil Based Mud
Purple	Glycol
Pink (Black/ Brown Strip)	Base Oil / Fuel Oil
No Colour	Scale Inhibitor



External Swage or Crimp Ferrules are usually supplied in Yellow Zinc Plated finish.

Hookie - Hook Hose Lifter



Dixon are able to supply hose lifters specifically designed for use with Bulk Loading Hose/ Hookie Hook Stems.

Manufactured in forged carbon steel. All Hoselifters are supplied with proof load test and material (3.1) certificates and are available in bore sizes 3", 4" and 5". Safe working load is 4 Tons, with a proof load test of 8 Tons. Hose Lifters are supplied complete with retaining clamp.

HOOKIE - HOOK HOSE LIFTER	
PART NO.	SIZE
HA0900-3	3"
HA0900-4	4"
HA0900-5	5"

Holedall® Swaging Machines





This latest range of Holedall Internal Expansion & External Swage Machines have been specifically designed and developed to provide a fast, effective, economic and safe method of attaching couplings to hose.

H

HOLEDALL SWAGING MACHINES

Benefits of Internal Expansion:

- Easy safe & consistent assembly.
- Virtual full - flow bore
- Full 360° uninterrupted internal expansion.
- Secure - out performs clamps & bands.
- Excellent sealing & retention between coupling & hose
- Reduced turbulence through the hose
- Fully complies with BSEN 1765/ BS:EN 1435/ EN: 14421
- Reduced risk of bacteria traps in hygienic hose assemblies

MACHINE RANGES	SWAGING CAPACITY	HYDRAULIC RAM	HYDRAULIC UNIT	OIL RESERVOIR	PRESSURE INDICATION	ELECTRICAL POWER	OPERATION	SIZE MM	SAFETY FEATURES
 T-20 IX	1"- 3" Nominal Bore, Threaded, Victaulic, Flanged, Hygienic Couplings etc.. Internal Swage	160mm Stroke x20 ton pull @10,000 psi (700bar)	Power Team 2 Stage 300ccu./min	4.5 litre capacity with sight glass	100mm diameter guage 0-700 bar	100mm diameter guage 0-700 bar	Power Supply : 230 v, 1ph, 50Hz	345 x 200 x 205	CE Marked in accordance with European Legislation
 T-50 IX	1"- 6" Nominal Bore, Threaded, Victaulic, Flanged, Hygienic Couplings etc.. Internal Swage	400mm Stroke x52 ton pull @5,000 (350bar)	Submerged 3/16L/min Gear/Piston Pump Assembly	70 litre capacity with sight glass	100mm diameter guage 0-350 bar	100mm diameter guage 0-350 bar	Main Motor 3Kw, Power Supply : 380/415 v, 3ph, 50Hz	1000 x 550 x 785	CE Marked in accordance with European Legislation
 T-100 IX	1"- 12" Nominal Bore, Threaded, Victaulic, Flanged, Hygienic Couplings etc.. Internal Swage	550mm Stroke x75 ton pull, @10,000psi (700bar)	Submerged 18L/min Gear/Piston Pump Assembly	70 litre capacity with sight glass	100mm diameter guage 0-700 bar	100mm diameter guage 0-700 bar	Main Motor 4Kw, Power Supply : 380/415 v, 3ph, 50Hz	1000 x 650 x 700	CE Marked in accordance with European Legislation
 T-350	2"- 14" Nominal Bore, Specially, developed for, Swaging Rotary Drilling Hose Dual Swage	915mm Stroke x188 ton pull and 2 Galls/min 354 ton push	4 Galls/min @3,500 psi sight glass @10,000 psi	100 litre capacity with sight glass	100mm diameter guage 0-1000 bar Digital Chart Recorder Available	100mm diameter guage 0-1000 bar Digital Chart Recorder Available	Main Motor 11Kw, Power Supply : 380/415 v, 3ph, 50/60Hz	3600 x 2554 x 1016	CE Marked in accordance with European Legislation

Holedall® Internal Expansion Machine Tooling

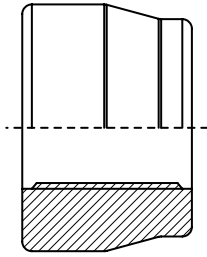

MODEL T-20 OPTIONAL TOOLING LIST	
PART NO.	DESCRIPTION
HA0812	Master Adapter Swaging Plate
HA0844	Draw-Bar for 2", 2.5", 3" IX Dolly
HA0829	Draw-Bar for 1", 1.25", 1.5" IX Dolly
HA0307	1" Internal Expansion Dolly
HA0308	1.5" Internal Expansion Dolly
HA0012	2" Internal Expansion Dolly
HA0013	2.5" Internal Expansion Dolly
HA0014	3" Internal Expansion Dolly

Swaging Plates are available to suit various end terminations.

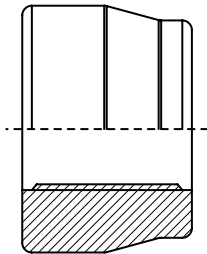

MODEL T - 50 OPTIONAL TOOLING LIST	
PART NO.	DESCRIPTION
HA0019	Adapter Kit for 2", 2 1/2", 3" Unflanged Couplings Consisting of: Spool Piece (HA0019A): 2", 2 1/2", 3" Swaging Plates (HA0019B/C/D): Adapter for 2", 2 1/2", 3" Dolly's (HA0019E)
HA0012	2" Internal Expansion Dolly
HA0013	2 1/2" Internal Expansion Dolly
HA0014	3" Internal Expansion Dolly
HA0020	4" Internal Expansion Dolly

H

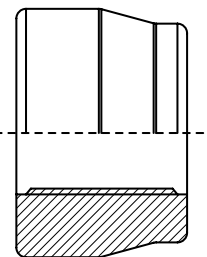

MODEL T - 100 OPTIONAL TOOLING LIST	
PART NO.	DESCRIPTION
HA0011	Adapter Kit for 2", 2 1/2", 3" Unflanged Couplings Consisting of: Spool Piece (HA0011A): 2", 2 1/2", 3" Swaging Plates (HA0011B/C/D): Adapter for 2", 2 1/2", 3" Dolly's (HA0011E): Ram Sleeve and Extension (HA0011F).
HA0012	2" Internal Expansion Dolly
HA0013	2 1/2" Internal Expansion Dolly
HA0014	3" Internal Expansion Dolly
HA0015	4" Internal Expansion Dolly
HA0016	5" Internal Expansion Dolly
HA0017	6" Internal Expansion Dolly
HA0018	8" Internal Expansion Dolly
HA0005	10" Internal Expansion Dolly
HA0365	12" Internal Expansion Dolly (T100 Only)

Additional Adapter Kits and Dolly's are available for all machines to internally Expand couplings below 2" nominal bore.

Dixon Group Europe Ltd are able to supply external swaging dies, Internal Expansion Dolly's and tooling to suit Mulcorams, Shand UK and other manufacturers Swaging machines. Contact Dixon for details.

NOTE: Internal Expansion Dollys are also available for metric bore hose

Holedall® High Pressure & Custom Made Couplings

Dixon Group Europe Ltd, whilst being the manufacturer and distributor of the standard range of HOLEDALL High Performance Hose Couplings are also able to supply a variety of custom designed couplings with a wide range of end configurations and service applications. Design variables of coupling length, materials, wall thickness and serration detail provide for installations ranging from lightweight industrial hose to high pressure hoses used in hazardous environments offshore.

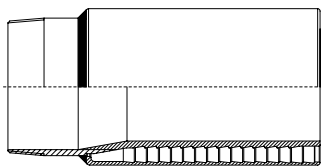

Holedall® High Pressure Coupling Assembly

The Holedall High Pressure Coupling Assembly can be supplied for either Internal Expansion or External Swage for working pressures of up to 2,500 psi (170 bar) in size 2" through 10". The assembly is supplied as a one-piece unit with the ferrule being welded to the stem. The assembly can be supplied in various materials including: Stainless Steel and Carbon Steels with Charpy Impact Testing conforming to NACE STD MR-01-75 for both Sour and Non-Sour services.

End terminations include: Welding Neck Flange, API/NPT Thread and Hammer Lug Union.

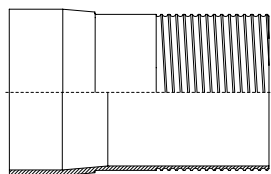

Holedall® Composite Hose Scroll Tails

Composite Hose Tails are produced for leading Composite Hose Manufacturers in both Carbon and Stainless Steels with fixed and swivel flanged, Victaulic groove and threaded end terminations for External Crimping and Swaging in nominal bore sizes up to 10".



Holedall® Hammer Lug Union End Termination

Holedall IX stem with integral 4" fig 206 hammer lug union end termination. Holedall EC stem with integral 4" fig 206 hammer lug union end termination for UHMWPE, XLPE and chemical hose.

- Male sub and Dixon branded nut
- Female sub



Whatever your application, the Holedall brand of high integrity hose couplings are engineered for the exacting service that is demanded by industry today.

Leak-free sealing, coupling retention and maximum end-load capability is achieved with this permanently attached interlocking coupling system.

The Holedall design is simple...the performance impressive.

Holedall® Swaged Rotary Drilling Hose Coupling System

In conjunction with the World's leading Rotary/Vibrator Drilling Hose manufacturers, Dixon have developed the Holedall Swaged Rotary Hose Coupling Assembly System. This technology enables both Hose manufacturers and distributors alike to produce safe and secure High Pressure Mud/Rotary Hose Assemblies, in a fraction of the time it traditionally takes using built-in couplings.

These couplings are used for both land-based and offshore drilling operations involving down linking, directional drilling, negative pressure pulses etc. which occur in today's advanced drilling technologies

Typical Drilling Rig Components.

- | | | |
|---------------------------|--|---|
| 1 Mud tank | 11 Traveling block | 21 Drill floor |
| 2 Shale shakers | 12 Drill line | 22 Bell nipple |
| 3 Suction line (mud pump) | 13 Crown block | 23 Blowout preventer (BOP) Annular |
| 4 Mud pump | 14 Derrick | 24 Blowout preventers (BOPs) pipe ram & shear ram |
| 5 Motor or power source | 15 Monkey board | 25 Drill string |
| 6 Vibrating hose | 16 Stand (of drill pipe) | 26 Drill bit |
| 7 Draw-works (winch) | 17 Pipe rack (floor) | 27 Casing head |
| 8 Standpipe | 18 Swivel (On modern rigs this may be replaced by a top drive) | 28 Flow lin |
| 9 Rotary/Kelly hose | 19 Kelly drive | |
| 10 Goose-neck | 20 Rotary table | |

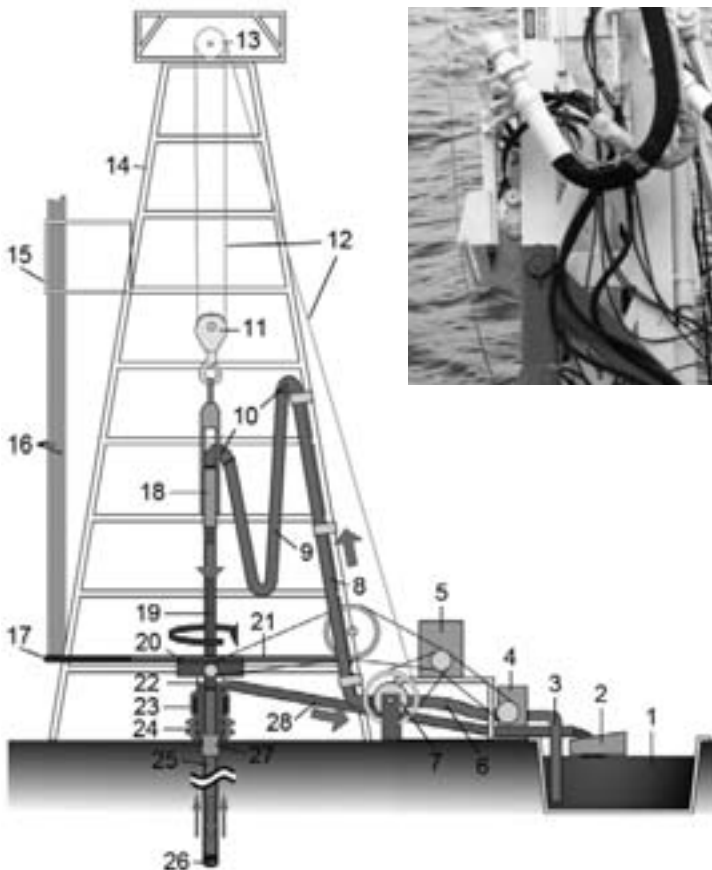

Testing

Dixon Holedall Rotary Couplings have been fully tested and certified by DNV in Hose Assemblies which comply with API 7K fifth edition (June 2010). Couplings are suitable for FSL1 and FSL2 service. Qualification testing and additional testing includes:

- Deformation Test under Pressure
- Ambient Temperature Bending Test
- Low Temperature Bending Test
- Low frequency pulsation test
- Hydrostatic Test
- Burst test



Rotary Couplings

Dixon Holedall Rotary Hose Couplings are available in API Line Pipe Thread and Butt Weld end terminations in nominal bore sizes 2½", 3", 3½" & 4" grades C, D & E, and are available to suit most Rotary Hose manufacture's hose.

Other end terminations are available; e.g. Hammer Lug Unions, Flanges, Hubs etc. A selection Two different classes of coupling are available: 'API 7K' and 'Standard' All 'API 7K' couplings, have a identified by a unique serial number, low stress stamped on the coupling and are supplied with a full certification dossier which includes Material, NDE and Welding Certification in accordance with ASME IX. 'Standard' Couplings are supplied with material certification only. Couplings are also available to suit Russian Gost 25676 Standard.

H

Dixon-Holedall T-350 Swaging Machine

To complement the Dixon-Holedall Rotary Coupling we have designed and developed a Swaging machine specifically for assembling Rotary Hose. 350 tons of swaging force and 190 tons of pulling force permit swaging in one pass, eliminating the need to use multiple dies. The machines are available with a number of options, Digital Chart Recorder, Overhead Gantry, Electric Hoists etc.

The machine is also suitable for both External and Internal Swaging of general industrial hose up to 14" nominal bore with a ASA 150lb Flange, and is available to suit all International electrical power requirements. Machines supplied into the EC carry the CE Mark .



Dixon Hammer Unions - Standard Service



100 Series

Note: Buttweld and socket weld configurations and other materials are available.

- Used on low pressure manifolds and lines and in applications running air, water, oil or gas up to 1,000 psi NSCWP (non-shock cold working pressure)

100 SERIES			
PART NO.	SIZE	DESCRIPTION	NSCWP
HU100200	2"	2" Hammer Union - 100 series, yellow, black nut	1000
HU100250	2 1/2"	2 1/2" Hammer Union - 100 series, yellow, black nut	1000
HU100300	3"	3" Hammer Union - 100 series, yellow, black nut	1000
HU100400	4"	4" Hammer Union - 100 series, yellow, black nut	1000
HU100600	6"	6" Hammer Union - 100 series, yellow, black nut	1000
HU100800	8"	6" Hammer Union - 100 series, yellow, black nut	1000



Example of Buttweld and Socket Weld configuration.

- Used in general service applications running air, water, oil or gas up to 2,000 psi NSCWP (non-shock cold working pressure)



200 SERIES			
PART NO.	SIZE	DESCRIPTION	NSCWP
HU200100	1"	1" Hammer Union - 200 series, grey sub, blue nut	2000
HU200150	1 1/2"	1 1/2" Hammer Union - 200 series, grey sub, blue nut	2000
HU200200	2"	2" Hammer Union - 200 series, grey sub, blue nut	2000
HU200250	2 1/2"	2 1/2" Hammer Union - 200 series, grey sub, blue nut	2000
HU200300	3"	3" Hammer Union - 200 series, grey sub, blue nut	2000
HU200400	4"	4" Hammer Union - 200 series, grey sub, blue nut	2000
HU200600	6"	6" Hammer Union - 200 series, grey sub, blue nut	2000

H

- O-ring mounted sub provides excellent sealing properties
- Runs air, water, oil or gas up to 2,000 psi NSCWP (non-shock cold working pressure)



206 SERIES			
PART NO.	SIZE	DESCRIPTION	NSCWP
HU206100	1"	1" Hammer Union - 206 series, grey sub, blue nut	2000
HU206150	1 1/2"	1 1/2" Hammer Union - 206 series, grey sub, blue nut	2000
HU206200	2"	2" Hammer Union - 206 series, grey sub, blue nut	2000
HU206250	2 1/2"	2 1/2" Hammer Union - 206 series, grey sub, blue nut	2000
HU206300	3"	3" Hammer Union - 206 series, grey sub, blue nut	2000
HU206400	4"	4" Hammer Union - 206 series, grey sub, blue nut	2000
HU206600	6"	6" Hammer Union - 206 series, grey sub, blue nut	2000

Permanently Attached Couplings - Holedall® System

- Lip type seal ring minimises fluid flow turbulence while creating a pressure seal
- For use in mud, manifold service and truck mounting applications running air, water, oil, gas or mud up to 6,000 psi NSCWP (non-shock cold working pressure)



602 SERIES

PART NO.	SIZE	DESCRIPTION	NSCWP
HU602100	1"	1" Hammer Union - 602 series, orange sub, black nut	6000
HU602200	2"	2" Hammer Union - 602 series, orange sub, black nut	6000

- Lip type seal ring minimises fluid flow turbulence while creating a pressure seal
- For use in high pressure systems and truck mounting applications running air, water, oil, gas or mud up to 10,000 psi NSCWP (non-shock cold working pressure)



1002 SERIES

PART NO.	SIZE	DESCRIPTION	NSCWP
HU1002100	1"	1" Hammer Union - 1002 series, blue sub, red nut	1000
HU1002200	2"	2" Hammer Union - 1002 series, blue sub, red nut	1000
HU1002400	4"	4" Hammer Union - 1002 series, blue sub, red nut	1000

- Lip type seal ring minimises fluid flow turbulence while creating a pressure seal
- For use in extreme high pressure applications running air, water, oil, gas or mud up to 15,000 psi NSCWP (non-shock cold working pressure)



1502 SERIES

PART NO.	SIZE	DESCRIPTION	NSCWP
HU1502200	2"	2" hammer union - 1502 series, red sub, blue nut	15000

H



H

Quick Release Couplings

Quick Release Profiles	270-272
H Series: ISO 7241 Series B Interchange	273-277
H-Series ISO-B Food Grade Couplings.....	278
HS-Series ISO-B Steam Interchange	279
K-Series ISO7241 Series 'A' Interchange	280-281
AG-Series Agricultural Interchange.....	282-283
TR-Series TEMA European Interchange	284
VEP-Series Threaded Flushface	285
W Series Wing Style Interchange	286-287
HT-Series ISO16028 Flushface Interchange	288-290
ST-Series Snap-Tite '71' Interchange	291-293
WS-Series High Pressure Wingstyle.....	294-295
WS-Series Blowout Prevention Safety Coupling	296
PD-Series ISO15171-1 Diagnostic Interchange.....	297
V Series: Snap-Tite H/IH Interchange.....	298-303
T-Series High Pressure Screw-Together	304

CVV-Series European Screw-Together Interchange.....	305
E-Series Straight-Through Interchange	306-308
EA-Series Water-Blast Interchange	309
CM-Series Mould Coolant Interchange	310-312
DF-Series Industrial Interchange	313-318
BR-Series Rectus '21' Interchange	319-320
J-Series Truflate Automotive Interchange.....	321-323
CJ-Series European High-Flow Interchange.....	324-326
N Series Bowes/MacDonald Interchange.....	327-332
P-Series Thor Interchange.....	333-335

**FOR A FULL RANGE OF HOSES
TO COMPLEMENT THESE FITTINGS SEE SECTION F**

**QUICK DISCONNECT COUPLING FLUID COMPATIBILITY GUIDE
AVAILABLE ON PAGES 500-501 OF THE TECHNICAL SECTION**



Quick Release Couplings

Quick Release Profiles

Dixon T-Series

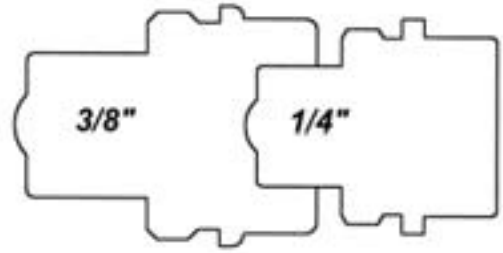

Dixon CM-Series

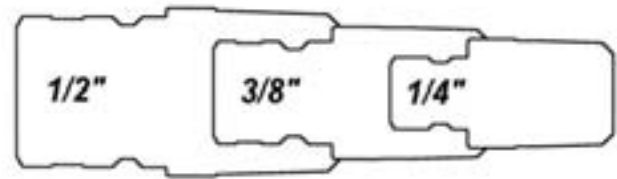

Dixon W-Series

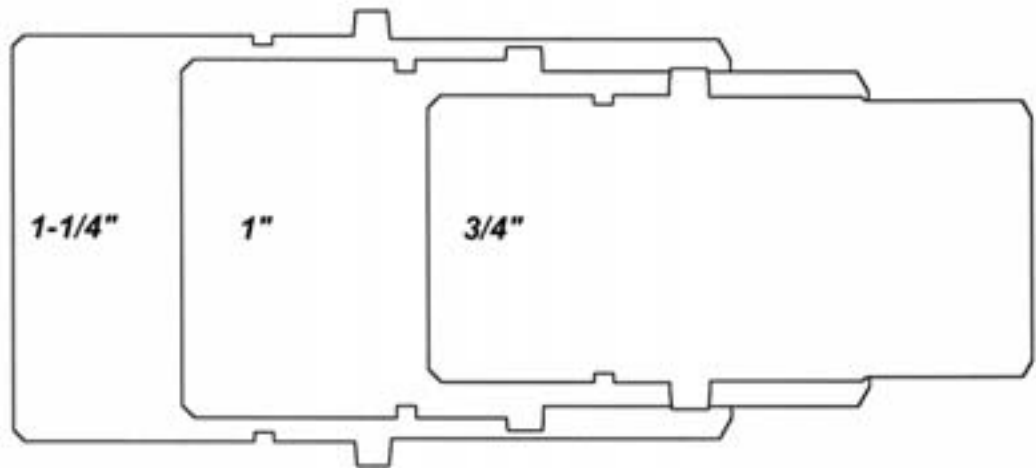

Dixon ST-Series

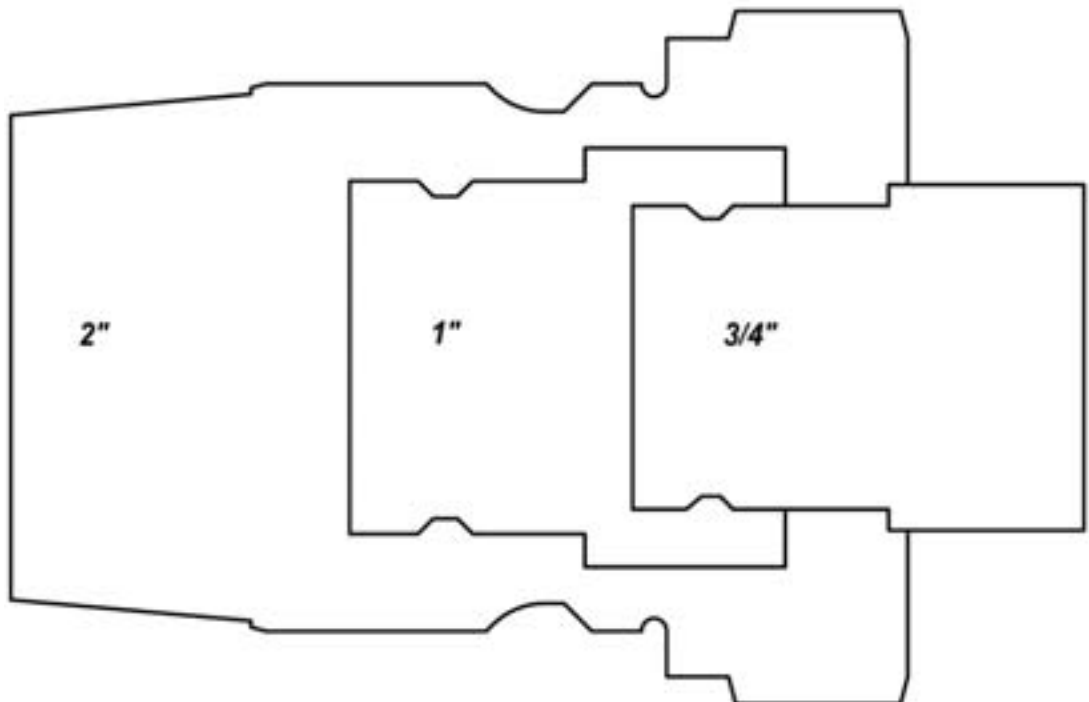

Dixon H-Series

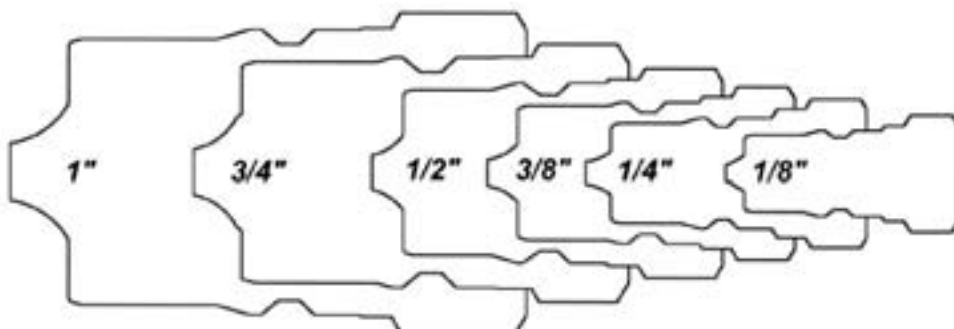

Dixon V-Series

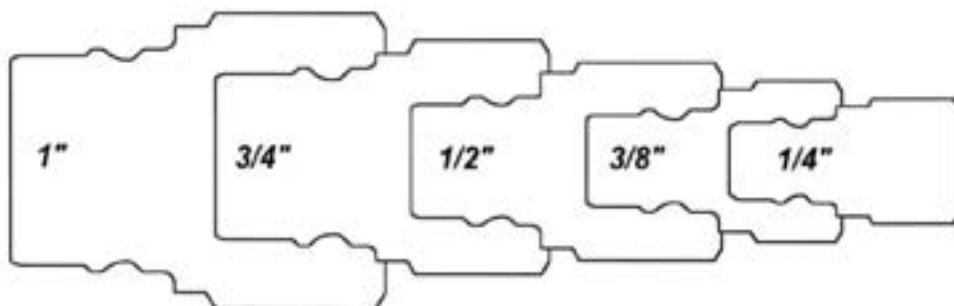

Dixon E-Series

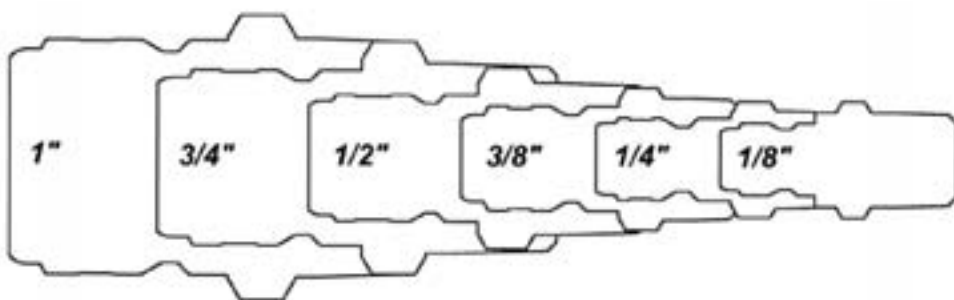

Dixon K-Series

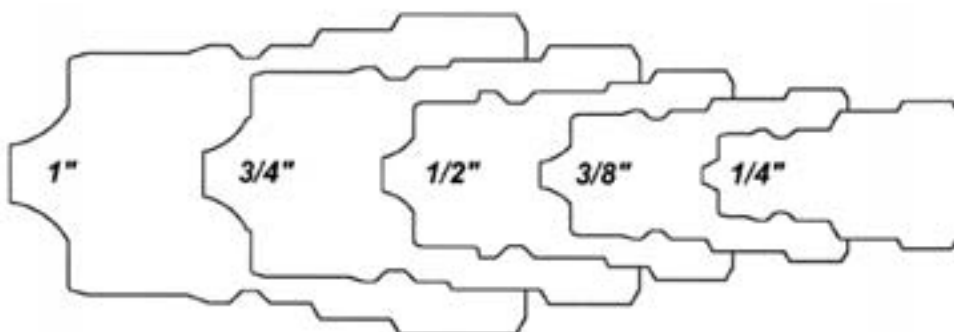

Dixon HT-Series

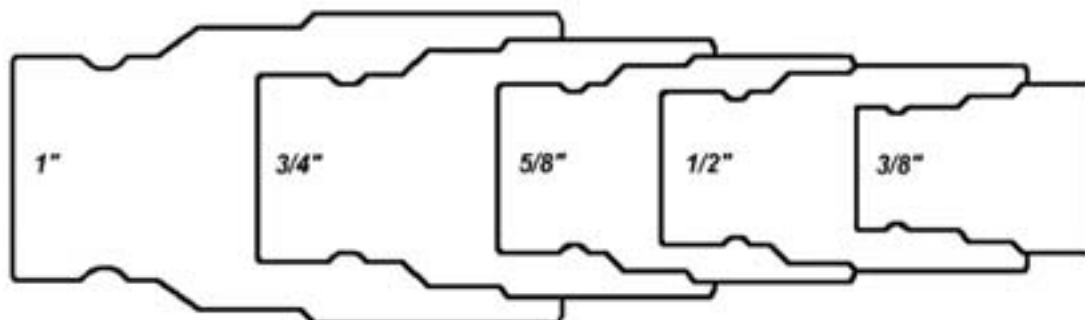

Quick Release Couplings

Dixon BR-Series

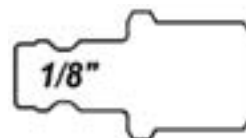

Dixon CL-Series



Dixon L-Series



Dixon NK-Series Dixon CJ-Series



Dixon A-Series

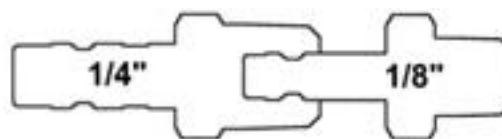

Dixon M-Series



Dixon J-Series

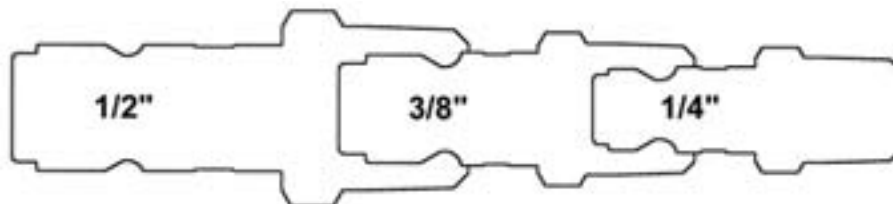

Dixon DF-Series

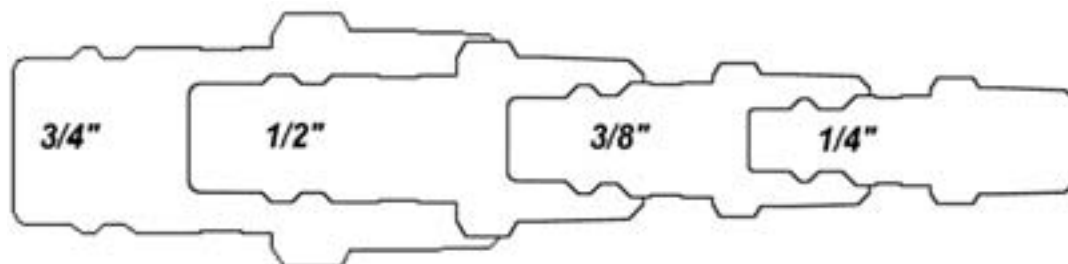

H Series: ISO 7241 Series B Interchange

- H-Series couplers and nipples are fully compliant with the parameters outlined in ISO7241 Series 'B'
- A wide variety of body and seal materials are available to maximise compatibility in a variety of applications
- Large diameter heavy duty knurled sleeves are designed to resist brinelling and maximise performance under impulse conditions
- Wide selection of thread configurations to ensure compatibility in a variety of installations



PERFORMANCE SPECIFICATIONS	OPERATING bar (psi)	BURST bar (psi)	FLOW RATE $\Delta P=2$ bar	LOCKING MECHANISM
1/8" Steel	379 (5,500)	1,448 (21,000)	12 LPM (3.2 GPM)	8 Balls
1/4" Steel	345 (5,000)	1,344 (19,500)	26 LPM (7 GPM)	8 Balls
3/8" Steel	345 (5,000)	1,241 (18,000)	45 LPM (12 GPM)	9 Balls
1/2" Steel	354 (5,000)	1,103 (16,000)	76 LPM (20 GPM)	9 Balls
3/4" Steel	310 (4,500)	1,103 (16,000)	151 LPM (40 GPM)	12 Balls
1" Steel	310 (4,500)	1,103 (16,000)	246 LPM (65 GPM)	12 Balls
1 1/4" Steel	103 (1,500)	413 (6,000)	404 LPM (107 GPM)	12 Balls
1 1/2" Steel	124 (1,800)	489 (7,100)	473 LPM (125 GPM)	12 Balls

Please Note: For 316SS and 303SS operating pressure, multiply the operating pressures above by 0.60.

PERFORMANCE SPECIFICATIONS	OPERATING bar (psi)	BURST bar (psi)	FLOW RATE $\Delta P=2$ bar	LOCKING MECHANISM
1/8" Brass	207 (3,000)	827 (12,000)	12 LPM (3.2 GPM)	8 Balls
1/4" Brass	259 (3,750)	1,034 (15,000)	26 LPM (7 GPM)	12 Balls
3/8" Brass	241 (3,500)	965 (14,000)	45 LPM (12 GPM)	12 Balls
1/2" Brass	207 (3,000)	827 (12,000)	76 LPM (20 GPM)	12 Balls
3/4" Brass	155 (2,250)	621 (9,000)	151 LPM (40 GPM)	12 Balls
1" Brass	103 (1,500)	414 (6,000)	246 LPM (65 GPM)	12 Balls
1 1/4" Brass	69 (1,000)	220 (3,200)	404 LPM (107 GPM)	18 Balls
1 1/2" Brass	69 (1,000)	248 (3,600)	473 LPM (125 GPM)	20 Balls

PERFORMANCE SPECIFICATIONS	OPERATING bar (psi)	BURST bar (psi)	FLOW RATE $\Delta P=2$ bar	LOCKING MECHANISM
1/8" 303 SS	207 (3,000)	1,241 (18,000)	12 LPM (3.2 GPM)	8 Balls
1/4" 303 SS	259 (3,750)	2,000 (29,000)	26 LPM (7 GPM)	8 Balls
3/8" 303 SS	241 (3,500)	1,241 (18,000)	45 LPM (12 GPM)	9 Balls
1/2" 303 SS	207 (3,000)	1,241 (18,000)	76 LPM (20 GPM)	9 Balls
3/4" 303 SS	155 (2,250)	1,379 (20,000)	151 LPM (40 GPM)	12 Balls
1" 303 SS	103 (1,500)	1,103 (16,000)	246 LPM (65 GPM)	12 Balls
1 1/4" 303 SS	69 (1,000)	352 (5,100)	404 LPM (107 GPM)	12 Balls
1 1/2" 303 SS	69 (1,000)	379 (5,500)	473 LPM (125 GPM)	12 Balls
1/8" 316 SS	207 (3,000)	1,241 (18,000)	12LPM (3.2 GPM)	8 Balls

PERFORMANCE SPECIFICATIONS	OPERATING bar (psi)	BURST bar (psi)	FLOW RATE $\Delta P=2$ bar	LOCKING MECHANISM
1/4" 316 SS	259 (3,750)	2,000 (29,000)	26LPM (7 GPM)	8 Balls
3/8" 316 SS	241 (3,500)	1,586 (23,000)	45LPM (12 GPM)	9 Balls
1/2" 316 SS	207 (3,000)	1,275 (18,500)	76LPM (20 GPM)	9 Balls
3/4" 316 SS	155 (2,250)	1,172 (17,000)	151LPM (40 GPM)	12 Balls
1" 316 SS	103 (1,500)	1,034 (15,000)	246LPM (65 GPM)	12 Balls
1 1/4" 316 SS	69 (1,000)	359 (5,200)	404LPM (107 GPM)	12 Balls
1 1/2" 316 SS	69 (1,000)	366 (5,300)	473LPM (125 GPM)	12 Balls

Quick Release Couplings

INTERCHANGE STANDARDS	US MILITARY	INDUSTRY STANDARDS	INTERNATIONAL STANDARDS	ANSI/NFPA
1/8"	-	-	*	*
1/4"	-	-	ISO7241-B	B93.113M-B
3/8"	-	-	ISO7241-B	B93.113M-B
1/2"	-	-	ISO7241-B	B93.113M-B
3/4"	-	-	ISO7241-B	B93.113M-B
1"	-	-	ISO7241-B	B93.113M-B
1 1/4"	-	-	*	*
1 1/2"	-	-	*	*

* These particular sizes are not outlined within the documented standard category.

"H" SERIES INTERCHANGE	PARKER	SNAP TITLE	FASTER	HANSEN	STUCCHI	AEROQUIP/EATON
1/8"	60-Series	72-Series	Series 'HNV'	HK-Series	IRB/RBO/IRBXD series	FD45 series
1/4"	60-Series	72-Series	Series 'HNV'	HK-Series	IRB/RBO/IRBXD series	FD45 series
3/8"	60-Series	72-Series	Series 'HNV'	HK-Series	IRB/RBO/IRBXD series	FD45 series
1/2"	60-Series	72-Series	Series 'HNV'	HK-Series	IRB/RBO/IRBXD series	FD45 series
3/4"	60-Series	72-Series	Series 'HNV'	HK-Series	IRB/RBO/IRBXD series	FD45 series
1"	60-Series	72-Series	Series 'HNV'	HK-Series	IRB/RBO/IRBXD series	FD45 series
1 1/4"	-	-	-	HK-Series	IRB/RBO/IRBXD series	FD45 series
1 1/2"	60-Series	-	Series 'HNV'	HK-Series	IRB/RBO/IRBXD series	FD45 series



H-SERIES ISO-B INTERCHANGE (COUPLER)

PART NO.	BODY SIZE	CAP LANYARD	BODY MATERIAL
H1M2	1/8"	1/4" - 18 NPTF	Steel
H10M3	1/8"	9/16" - 18 ORB	Steel
H2M3	1/4"	3/8" - 18 NPTF	Steel



H-SERIES ISO-B INTERCHANGE (COUPLER DUST PLUG)

PART NO.	BODY SIZE	CAP LANYARD	BODY MATERIAL
1HDP	1/8"	Elastomer	Elastomer
2HDP	1/4"	Elastomer	Elastomer
3HDP	3/8"	Elastomer	Elastomer
4HDP	1/2"	Elastomer	Elastomer
6HDP	3/4"	Elastomer	Elastomer
8HDP	1"	Elastomer	Elastomer



H-SERIES ISO-B INTERCHANGE (NIPPLE DUST CAP)

PART NO.	BODY SIZE	CAP LANYARD	BODY MATERIAL
H1DC	1/8"	Elastomer	Elastomer
H2DC	1/4"	Elastomer	Elastomer
H3DC	3/8"	Elastomer	Elastomer
H4DC	1/2"	Elastomer	Elastomer
H6DC	3/4"	Elastomer	Elastomer
H8DC	1"	Elastomer	Elastomer



H-SERIES ISO-B INTERCHANGE (COUPLER RIGID DUST PLUG)

PART NO.	BODY SIZE	CAP LANYARD	BODY MATERIAL
2HDP-A	1/4"	Steel Ring	Aluminum
3HDP-A	3/8"	Steel Ring	Aluminum
4HDP-A	1/2"	Steel Ring	Aluminum
6HDP-A	3/4"	Steel Ring	Aluminum
8HDP-A	1"	Steel Ring	Aluminum
12HDP-A	1 1/2"	Steel Ring	Aluminum



H-SERIES ISO-B INTERCHANGE (NIPPLE RIGID DUST CAP)

PART NO.	BODY SIZE	CAP LANYARD	BODY MATERIAL
H2DC-A	1/4"	Steel Ring	Aluminum
H3DC-A	3/8"	Steel Ring	Aluminum
H4DC-A	1/2"	Steel Ring	Aluminum
H6DC-A	3/4"	Steel Ring	Aluminum
H8DC-A	1"	Steel Ring	Aluminum
H12DC-A	1 1/2"	Steel Ring	Aluminum



H-SERIES ISO-B INTERCHANGE (NIPPLE PROTECTIVE PRESSURE CAP)

PART NO.	BODY SIZE	CAP LANYARD	BODY MATERIAL
H2PC	1/4"	none	Steel
H3PC	3/8"	none	Steel
H4PC	1/2"	none	Steel
H6PC	3/4"	none	Steel
H8PC	1"	none	Steel



(Female Thread)

H-SERIES ISO-B STEEL MILL 'SLIDE-GATE' INTERCHANGE (COUPLER)

PART NO.	BODY SIZE	THREAD SIZE	BODY MATERIAL
4HF4-HV	1/2"	1/2" - 14 NPTF	Steel



(Female Thread)

SERIES ISO-B STEEL MILL 'SLIDE-GATE' INTERCHANGE (NIPPLE)

PART NO.	BODY SIZE	THREAD SIZE	BODY MATERIAL
H4F4-HV	1/2"	1/2" - 14 NPTF	Steel

Quick Release Couplings

H-SERIES ISO-B INTERCHANGE (COUPLER)



(Female Thread)

PART NO.	BODY SIZE	THREAD SIZE	BODY MATERIAL
1HF1	1/8"	1/8"-27 NPTF	Steel
1HF1-B	1/8"	1/8"-27 NPTF	Brass
1HF1-S	1/8"	1/8"-27 NPTF	303 SS
1HF1-SS	1/8"	1/8"-27 NPTF	316 SS
1HOF2	1/8"	7/16"-20 ORB	Steel
2HF2	1/4"	1/4"-18 NPTF	Steel
2HF2-B	1/4"	1/4"-18 NPTF	Brass
2HF2-S	1/4"	1/4"-18 NPTF	303 SS
2HF2-SS	1/4"	1/4"-18 NPTF	316 SS
2HOF3	1/4"	9/16"-18 ORB	Steel
2HOF3-S	1/4"	9/16"-18 ORB	303 SS
2HOF3-SS	1/4"	9/16"-18 ORB	316 SS
2HBF2	1/4"	G1/4" BSPP	Steel
2HBF2-B	1/4"	G1/4" BSPP	Brass
2HBF2-S	1/4"	G1/4" BSPP	303 SS
2HBF2-SS	1/4"	G1/4" BSPP	316 SS
3HF3	3/8"	3/8"-18 NPTF	Steel
3HF3-B	3/8"	3/8"-18 NPTF	Brass
3HF3-S	3/8"	3/8"-18 NPTF	303 SS
3HF3-SS	3/8"	3/8"-18 NPTF	316 SS
3HOF4	3/8"	3/4"-16 ORB	Steel
3HOF4-S	3/8"	3/4"-16 ORB	303 SS
3HOF4-SS	3/8"	3/4"-16 ORB	316 SS
3HBF3	3/8"	G3/8" BSPP	Steel
3HBF3-B	3/8"	G3/8" BSPP	Brass
3HBF3-S	3/8"	G3/8" BSPP	303 SS
3HBF3-SS	3/8"	G3/8" BSPP	316 SS
4HF4	1/2"	1/2"-14 NPTF	Steel
4HF4-B	1/2"	1/2"-14 NPTF	Brass
4HF4-S	1/2"	1/2"-14 NPTF	303 SS
4HF4-SS	1/2"	1/2"-14 NPTF	316 SS
4HOF5	1/2"	7/8"-14 ORB	Steel
4HOF5-S	1/2"	7/8"-14 ORB	303 SS
4HOF5-SS	1/2"	7/8"-14 ORB	316 SS
4HBF4	1/2"	G1/2" BSPP	Steel
4HBF4-B	1/2"	G1/2" BSPP	Brass
4HBF4-S	1/2"	G1/2" BSPP	303 SS
4HBF4-SS	1/2"	G1/2" BSPP	316 SS
6HF6	3/4"	3/4"-14 NPTF	Steel
6HF6-B	3/4"	3/4"-14 NPTF	Brass
6HF6-S	3/4"	3/4"-14 NPTF	303 SS
6HF6-SS	3/4"	3/4"-14 NPTF	316 SS
6HOF6	3/4"	1 1/16"-12 ORB	Steel
6HOF6-S	3/4"	1 1/16"-12 ORB	303 SS
6HOF6-SS	3/4"	1 1/16"-12 ORB	316 SS
6HBF6	3/4"	G3/4" BSPP	Steel
6HBF6-B	3/4"	G3/4" BSPP	Brass
6HBF6-S	3/4"	G3/4" BSPP	303 SS
6HBF6-SS	3/4"	G3/4" BSPP	316 SS
8HF8	1"	1"-11 1/2 NPTF	Steel
8HF8-B	1"	1"-11 1/2 NPTF	Brass
8HF8-S	1"	1"-11 1/2 NPTF	303 SS
8HF8-SS	1"	1"-11 1/2 NPTF	316 SS
8HOF8	1"	1 5/16"-12 ORB	Steel
8HOF8-S	1"	1 5/16"-12 ORB	303 SS
8HOF8-SS	1"	1 5/16"-12 ORB	316 SS
8HBF8	1"	G1" BSPP	Steel
8HBF8-B	1"	G1" BSPP	Brass
8HBF8-S	1"	G1" BSPP	303 SS
8HBF8-SS	1"	G1" BSPP	316 SS
10HF10	1 1/4"	1 1/4"-11 1/2 NPTF	Steel
10HF10-B	1 1/4"	1 1/4"-11 1/2 NPTF	Brass
10HF10-S	1 1/4"	1 1/4"-11 1/2 NPTF	303 SS
10HF10-SS	1 1/4"	1 1/4"-11 1/2 NPTF	316 SS
10HBF10	1 1/4"	G1 1/4" BSPP	Steel
10HBF10-B	1 1/4"	G1 1/4" BSPP	Brass
10HBF10-S	1 1/4"	G1 1/4" BSPP	303 SS
10HBF10-SS	1 1/4"	G1 1/4" BSPP	316 SS
12HF10	1 1/2"	1 1/4"-11 1/2 NPTF	Steel
12HF10-B	1 1/2"	1 1/4"-11 1/2 NPTF	Brass
12HF10-S	1 1/2"	1 1/4"-11 1/2 NPTF	306 SS
12HOF10	1 1/2"	1 5/8"-12 ORB	Steel
12HF12	1 1/2"	1 1/2"-11 1/2 NPTF	Steel
12HF12-B	1 1/2"	1 1/2"-11 1/2 NPTF	Brass
12HF12-S	1 1/2"	1 1/2"-11 1/2 NPTF	303 SS
12HF12-SS	1 1/2"	1 1/2"-11 1/2 NPTF	316 SS
12HOF12	1 1/2"	1 7/8"-12 ORB	Steel
12HBF12	1 1/2"	G1 1/2" BSPP	Steel
12HBF12-B	1 1/2"	G1 1/2" BSPP	Brass
12HBF12-S	1 1/2"	G1 1/2" BSPP	303 SS
12HBF12-SS	1 1/2"	G1 1/2" BSPP	316 SS

H-SERIES ISO-B INTERCHANGE (NIPPLE)

PART NO.	BODY SIZE	THREAD SIZE	BODY MATERIAL
H1F1	1/8"	1/8"-27 NPTF	Steel
H1F1-B	1/8"	1/8"-27 NPTF	Brass
H1F1-S	1/8"	1/8"-27 NPTF	303 SS
H1F1-SS	1/8"	1/8"-27 NPTF	316 SS
H1OF2	1/8"	7/16"-20 ORB	Steel
H2F2	1/4"	1/4"-18 NPTF	Steel
H2F2-B	1/4"	1/4"-18 NPTF	Brass
H2F2-S	1/4"	1/4"-18 NPTF	303 SS
H2F2-SS	1/4"	1/4"-18 NPTF	316 SS
H2OF3	1/4"	9/16"-18 ORB	Steel
H2OF3-S	1/4"	9/16"-18 ORB	303 SS
H2OF3-SS	1/4"	9/16"-18 ORB	316 SS
H2BF2	1/4"	G1/4" BSPP	Steel
H2BF2-B	1/4"	G1/4" BSPP	Brass
H2BF2-S	1/4"	G1/4" BSPP	303 SS
H2BF2-SS	1/4"	G1/4" BSPP	316 SS
H3F3	3/8"	3/8"-18 NPTF	Steel
H3F3-B	3/8"	3/8"-18 NPTF	Brass
H3F3-S	3/8"	3/8"-18 NPTF	303 SS
H3F3-SS	3/8"	3/8"-18 NPTF	316 SS
H3OF4	3/8"	3/4"-16 ORB	Steel
H3OF4-S	3/8"	3/4"-16 ORB	303 SS
H3OF4-SS	3/8"	3/4"-16 ORB	316 SS
H3BF3	3/8"	G3/8" BSPP	Steel
H3BF3-B	3/8"	G3/8" BSPP	Brass
H3BF3-S	3/8"	G3/8" BSPP	303 SS
H3BF3-SS	3/8"	G3/8" BSPP	316 SS
H4F4	1/2"	1/2"-14 NPTF	Steel
H4F4-B	1/2"	1/2"-14 NPTF	Brass
H4F4-S	1/2"	1/2"-14 NPTF	303 SS
H4F4-SS	1/2"	1/2"-14 NPTF	316 SS
H4OF5	1/2"	7/8"-14 ORB	Steel
H4OF5-S	1/2"	7/8"-14 ORB	303 SS
H4OF5-SS	1/2"	7/8"-14 ORB	316 SS
H4BF4	1/2"	G1/2" BSPP	Steel
H4BF4-B	1/2"	G1/2" BSPP	Brass
H4BF4-S	1/2"	G1/2" BSPP	303 SS
H4BF4-SS	1/2"	G1/2" BSPP	316 SS
H6F6	3/4"	3/4"-14 NPTF	Steel
H6F6-B	3/4"	3/4"-14 NPTF	Brass
H6F6-S	3/4"	3/4"-14 NPTF	303 SS
H6F6-SS	3/4"	3/4"-14 NPTF	316 SS
H6OF6	3/4"	1 1/16"-12 ORB	Steel
H6OF6-S	3/4"	1 1/16"-12 ORB	303 SS
H6OF6-SS	3/4"	1 1/16"-12 ORB	316 SS
H6BF6	3/4"	G3/4" BSPP	Steel
H6BF6-B	3/4"	G3/4" BSPP	Brass
H6BF6-S	3/4"	G3/4" BSPP	303 SS
H6BF6-SS	3/4"	G3/4" BSPP	316 SS
H8F8	1"	1"-11 1/2 NPTF	Steel
H8F8-B	1"	1"-11 1/2 NPTF	Brass
H8F8-S	1"	1"-11 1/2 NPTF	303 SS
H8F8-SS	1"	1"-11 1/2 NPTF	316 SS
H8OF8	1"	1 5/16"-12 ORB	Steel
H8OF8-S	1"	1 5/16"-12 ORB	303 SS
H8OF8-SS	1"	1 5/16"-12 ORB	316 SS
H8BF8	1"	G1" BSPP	Steel
H8BF8-B	1"	G1" BSPP	Brass
H8BF8-S	1"	G1" BSPP	303 SS
H8BF8-SS	1"	G1" BSPP	316 SS
H10F10	1 1/4"	1 1/4"-11 1/2 NPTF	Steel
H10F10-B	1 1/4"	1 1/4"-11 1/2 NPTF	Brass
H10F10-S	1 1/4"	1 1/4"-11 1/2 NPTF	303 SS
H10F10-SS	1 1/4"	1 1/4"-11 1/2 NPTF	316 SS
H10BF10	1 1/4"	G1 1/4" BSPP	Steel
H10BF10-B	1 1/4"	G1 1/4" BSPP	Brass
H10BF10-S	1 1/4"	G1 1/4" BSPP	303 SS
H10BF10-SS	1 1/4"	G1 1/4" BSPP	316 SS
H12F10	1 1/2"	1 1/4"-11 1/2 NPTF	Steel
H12F10-B	1 1/2"	1 1/4"-11 1/2 NPTF	Brass
H12F10-S	1 1/2"	1 1/4"-11 1/2 NPTF	303 SS
H12OF10	1 1/2"	1 5/8"-12 ORB	Steel
H12F12	1 1/2"	1 1/2"-11 1/2 NPTF	Steel
H12F12-B	1 1/2"	1 1/2"-11 1/2 NPTF	Brass
H12F12-S	1 1/2"	1 1/2"-11 1/2 NPTF	303 SS
H12F12-SS	1 1/2"	1 1/2"-11 1/2 NPTF	316 SS
H12OF12	1 1/2"	1 7/8"-12 ORB	Steel
H12BF12	1 1/2"	G1 1/2" BSPP	Steel
H12BF12-B	1 1/2"	G1 1/2" BSPP	Brass
H12BF12-S	1 1/2"	G1 1/2" BSPP	303 SS
H12BF12-SS	1 1/2"	G1 1/2" BSPP	316 SS



(Female Thread)

H-Series ISO-B Food Grade Couplings

- H-Series couplers and nipples are fully compliant with the parameters outlined in ISO7241 Series 'B'
- Viton™ seals are FDA approved for Food Service applications, such as fryers and fryer-oil filtering equipment
- Large diameter flanged coupler sleeves will prevent damage when dropped and are easier to operate with gloves on
- Couplings of steel with nickel plating, 303SS and 316SS will fulfil the requirements of various food service applications



PERFORMANCE 'VALVED'	OPERATING bar (psi)	BURST bar (psi)	FLOW RATE ΔP=2 bar	LOCKING MECHANISM
1/2" Steel	293 (4,250)	1,172 (17,000)	76 LPM (20 GPM)	9 Balls
1/2" 303 SS	230 (3,333)	1,379 (20,000)	76 LPM (20 GPM)	9 Balls
1/2" 316 SS	213 (3,083)	1,276 (18,500)	76 LPM (20 GPM)	9 Balls

INTERCHANGE STANDARDS	US MILITARY	INDUSTRY STANDARDS	INTERNATIONAL STANDARDS	ANSI/NFPA
1/2"	-	-	ISO7241-B	B93.113M-B

HFG' SERIES INTERCHANGE	PARKER	AEROQUIP	-	-
1/2"	60-Series	FD45	-	-



(Female Thread)

H-SERIES ISO-B FOOD GRADE INTERCHANGE (SILICONE FLANGED COUPLER)

PART NO.	BODY SIZE	THREAD SIZE	BODY MATERIAL
D-4HF4-S-FSB	1/2"	1/2"-14 NPTF	303 SS
D-4HF4-SS-FSB	1/2"	1/2"-14 NPTF	316 SS



(Female Thread)

H-SERIES ISO-B FOOD GRADE INTERCHANGE (NYLON FLANGED COUPLER)

PART NO.	BODY SIZE	THREAD SIZE	BODY MATERIAL
D-4HF4-S-FNS	1/2"	1/2"-14 NPTF	303 SS
D-4HF4-SS-FNS	1/2"	1/2"-14 NPTF	316 SS



(Female Thread)

H-SERIES ISO-B FOOD GRADE INTERCHANGE (NIPPLE)

PART NO.	BODY SIZE	THREAD SIZE	BODY MATERIAL
D-H4F4-SV-8	1/2"	1/2"-14 NPTF	Steel
D-H4F4-S	1/2"	1/2"-14 NPTF	303 SS
D-H4F4-SS	1/2"	1/2"-14 NPTF	316 SS

HS-Series ISO-B Steam Interchange

- H-Series couplers and nipples are fully compliant with the parameters outlined in ISO7241 Series 'B'
- Flanged sleeves are designed for ease of sleeve operation while wearing gloves during connection and disconnection
- EPDM steam body and valve seals are formulated to withstand continuous steam service
- Brass couplers have a redundant o-ring to maximise service life and provide additional sealing integrity



PERFORMANCE SPECIFICATIONS	OPERATING bar (psi)	OPERATING C (F)	FLOW ΔP=0.4 bar (6.9 bar inlet)	LOCKING MECHANISM
1/4"	7 (100)	177° (350°)	49kg/hr (108lb/hr)	8 Balls
3/8"	7 (100)	177° (350°)	112kg/hr (246lb/hr)	9 Balls
1/2"	7 (100)	177° (350°)	166kg/hr (366lb/hr)	9 Balls
3/4"	7 (100)	177° (350°)	313kg/hr (689lb/hr)	12 Balls
1"	7 (100)	177° (350°)	540kg/hr (1190lb/hr)	12 Balls

Please Note (operating specifications): Operating pressure has been calculated using saturated steam at 170°C (338°F) for general purpose applications. Operating temperature is related to continuous steam service, with an intermittent maximum temperature of 204°C (400°F). For advanced operating pressure or super-heated steam specifications, contact the factory for further information.

INTERCHANGE STANDARDS	US MILITARY	INDUSTRY STANDARDS	INTERNATIONAL STANDARDS	ANSI/NFPA
All Sizes	-	-	ISO7241-B	B93.113M-B
HS' SERIES INTERCHANGE	PARKER	HANSEN	-	-
All Sizes	60-Series	HK-Series	-	-



(Female Thread)

H-SERIES ISO-B STEAM INTERCHANGE (COUPLER)

PART NO.	BODY SIZE	THREAD SIZE	BODY MATERIAL
2HSF2-B	1/4"	1/4"-18 NPTF	Brass
2HSF2-S	1/4"	1/4"-18 NPTF	303 SS
3HSF3-B	3/8"	3/8"-18 NPTF	Brass
3HSF3-S	3/8"	3/8"-18 NPTF	303 SS
4HSF4-B	1/2"	1/2"-14 NPTF	Brass
4HSF4-S	1/2"	1/2"-14 NPTF	303 SS
6HSF6-B	3/4"	3/4"-14 NPTF	Brass
6HSF6-S	3/4"	3/4"-14 NPTF	303 SS
8HSF8-B	1"	1-11"-1/2 NPTF	Brass
8HSF8-S	1"	1-11"-1/2 NPTF	303 SS



(Female Thread)

H-SERIES ISO-B STEAM INTERCHANGE (NIPPLE)

PART NO.	BODY SIZE	THREAD SIZE	BODY MATERIAL
HS2F2	1/4"	1/4"-18 NPTF	Steel
HS2F2-B	1/4"	1/4"-18 NPTF	Brass
HS2F2-S	1/4"	1/4"-18 NPTF	303 SS
HS3F3	3/8"	3/8"-18 NPTF	Steel
HS3F3-B	3/8"	3/8"-18 NPTF	Brass
HS3F3-S	3/8"	3/8"-18 NPTF	303 SS
HS4F4	1/2"	1/2"-14 NPTF	Steel
HS4F4-B	1/2"	1/2"-14 NPTF	Brass
HS4F4-S	1/2"	1/2"-14 NPTF	303 SS
HS6F6	3/4"	3/4"-14 NPTF	Steel
HS6F6-B	3/4"	3/4"-14 NPTF	Brass
HS6F6-S	3/4"	3/4"-14 NPTF	303 SS
HS8F8	1"	1"-11 1/2 NPTF	Steel
HS8F8-B	1"	1"-11 1/2 NPTF	Brass
HS8F8-S	1"	1"-11 1/2 NPTF	303 SS

K-Series ISO7241 Series "A" Interchange



- Interchange Data:**
- Interchangeable to ISO7241 Series 'A'
 - Parker 6600-Series, Aeroquip/Eaton FD56 (5600)
 - Faster ANV, Hansen HA15000, Safeway S56-Series, DNP-PAV 1 Series, Stucchi-BIR series

- Materials:**
- Machined components are manufactured using solid steel bar stock.
 - Stainless steel balls, retaining rings, and springs maximize corrosion resistance and extend service life.
 - Steel componentry is plated using ROHS Compliant Trivalent Chrome.
 - Steel coupler sleeves are hardened to resist deformation and maximise service life.
 - Steel nipples are hardened to provide heavy duty performance.

- Seal Components:**
- Nitrile (Buna-N) seals are standard, providing a temperature range of -40°C (-40°F) to +121°C (250°F).
 - Couplers have a PTFE Anti-Extrusion ring.
 - Valve seals are crimped in place to maintain integrity during excessive flow conditions and pressurised connection.

PERFORMANCE SPECIFICATIONS	OPERATING bar (psi)	COUPLED BURST bar (psi)	FLOW RATE ΔP=2 bar	LOCKING MECHANISM
1/4" Steel	350 (5,075)	1,260 (18,270)	12 LPM (3.2 GPM)	6 Balls
3/8" Steel	300 (4,350)	1,260 (18,270)	26 LPM (7 GPM)	10 Balls
1/2" Steel	300 (4,350)	1,000 (14,500)	45 LPM (12 GPM)	12 Balls
3/4" Steel	250 (3,625)	1,000 (14,500)	76 LPM (20 GPM)	12 Balls
1" Steel	207 (3,000)	800 (11,600)	151 LPM (40 GPM)	16 Balls
1 1/4" Steel	207 (3,000)	800 (11,600)	246 LPM (65 GPM)	16 Balls
1 1/2" Steel	160 (2,320)	640 (9,280)	404 LPM (107 GPM)	16 Balls
2" Steel	100 (1,450)	400 (5,800)	473 LPM (125 GPM)	15 Balls

INTERCHANGE STANDARDS	US MILITARY	INDUSTRY STANDARDS	INTERNATIONAL STANDARDS	ANSI/NFPA
1/4"	---	---	ISO7241-A	B93.113M-A
3/8"	---	---	ISO7241-A	B93.113M-A
1/2"	---	---	ISO7241-A	B93.113M-A
3/4"	---	---	ISO7241-A	B93.113M-A
1"	---	---	ISO7241-A	B93.113M-A
1 1/4"	---	---	ISO7241-A	B93.113M-A
1 1/2"	---	---	ISO7241-A	B93.113M-A
2"	---	---	ISO7241-A	B93.113M-A

'K' SERIES INTERCHANGE	PARKER	AEROQUIP	FASTER	HOLMBURY
1/4"	Series 6600	FD56 (5600)	ANV	ISO.A
3/8"	Series 6600	FD56 (5600)	ANV	ISO.A
1/2"	Series 6600	FD56 (5600)	ANV	ISO.A
3/4"	Series 6600	FD56 (5600)	ANV	ISO.A
1"	Series 6600	FD56 (5600)	ANV	ISO.A
1 1/4"	---	---	ANV	ISO.A
1 1/2"	---	---	ANV	ISO.A
2"	---	---	ANV	ISO.A



K-SERIES ISO-A INTERCHANGE (COUPLER DUST PLUG)			
PART NO.	BODY SIZE	CAP LANYARD	BODY MATERIAL
2KDP	1/4"	Elastomer	Elastomer
3KDP	3/8"	Elastomer	Elastomer
4KDP	1/2"	Elastomer	Elastomer
6KDP	3/4"	Elastomer	Elastomer
8KDP	1"	Elastomer	Elastomer



K-SERIES ISO-A INTERCHANGE (NIPPLE DUST CAP)

PART NO.	BODY SIZE	CAP LANYARD	BODY MATERIAL
K2DC	1/4"	Elastomer	Elastomer
K3DC	3/8"	Elastomer	Elastomer
K4DC	1/2"	Elastomer	Elastomer
K6DC	3/4"	Elastomer	Elastomer
K8DC	1"	Elastomer	Elastomer



(Female Thread)

K-SERIES ISO-A INTERCHANGE (COUPLER)

PART NO.	BODY SIZE	THREAD SIZE	BODY MATERIAL
2KF1	1/4"	1/8"-27 NPTF	Steel
2KF2	1/4"	1/4"-18 NPTF	Steel
2KBF2	1/4"	G1/4" BSPP	Steel
2KOF2	1/4"	7/16"-20 ORB	Steel
3KF3	3/8"	3/8"-18 NPTF	Steel
3KOF3	3/8"	9/16"-18 ORB	Steel
3KBF3	3/8"	G3/8" BSPP	Steel
4KF4	1/2"	1/2"-14 NPTF	Steel
4KOF4	1/2"	3/4"-16 ORB	Steel
4KBF4	1/2"	G1/2" BSPP	Steel
4KOF5	1/2"	7/8"-14 ORB	Steel
4KF6	1/2"	3/4"-14 NPTF	Steel
4KBF6	1/2"	1/2"-14 BSPP	Steel
6KF6	3/4"	3/4"-14 NPTF	Steel
6KOF6	3/4"	1-1/6"-12 ORB	Steel
6KBF6	3/4"	G3/4" BSPP	Steel
8KF8	1"	1"-11 1/2 NPTF	Steel
8KOF8	1"	1 5/16"-12 ORB	Steel
8KBF8	1"	G1" BSPP	Steel
10KF10	1 1/4"	1 1/4"-11 1/2 NPTF	Steel
10KBF10	1 1/4"	G1 1/4" BSPP	Steel
12KF12	1 1/2"	1 1/2"-11 1/2 NPTF	Steel
12KBF12	1 1/2"	G1 1/2" BSPP	Steel
16KF16	2"	2"-11 1/2 NPTF	Steel
16KBF16	2"	G2" BSPP	Steel

K-SERIES ISO-A INTERCHANGE (NIPPLE)

PART NO.	BODY SIZE	THREAD SIZE	BODY MATERIAL
K2F1	1/4"	1/8-27 NPTF	Steel
K2F2	1/4"	1/4"-18 NPTF	Steel
K2BF2	1/4"	G1/4" BSPP	Steel
K2OF2	1/4"	7/16"-20 ORB	Steel
K3F3	3/8"	3/8"-18 NPTF	Steel
K3OF3	3/8"	9/16"-18 ORB	Steel
K3BF3	3/8"	G3/8" BSPP	Steel
K4F4	1/2"	1/2"-14 NPTF	Steel
K4OF4	1/2"	3/4"-16 ORB	Steel
K4BF4	1/2"	G1/2" BSPP	Steel
K4OF5	1/2"	7/8"-14 ORB	Steel
K4F6	1/2"	3/4"-14 NPTF	Steel
K4BF6	1/2"	1/2"-14 BSPP	Steel
K6F6	3/4"	3/4"-14 NPTF	Steel
K6OF6	3/4"	1 1/6"-12 ORB	Steel
K6BF6	3/4"	G3/4" BSPP	Steel
K8F8	1"	1"-11 1/2 NPTF	Steel
K8OF8	1"	1 5/16"-12 ORB	Steel
K8BF8	1"	G1" BSPP	Steel
K10F10	1 1/4"	1 1/4"-11 1/2 NPTF	Steel
K10BF10	1 1/4"	G1 1/4" BSPP	Steel
K12F12	1 1/2"	1 1/2"-11 1/2 NPTF	Steel
K12BF12	1 1/2"	G1 1/2" BSPP	Steel
K16F16	2"	2"-11 1/2 NPTF	Steel
K16BF16	2"	G2" BSPP	Steel



(Female Thread)

AG-Series Agricultural Interchange

- AG-Series couplers and nipples are compliant with the parameters outlined in ISO5675 (ISO7241-1 Series 'A' for the 1/2" size)
- Couplers have a high concentration of locking balls to reduce incidents of brinneling during operation
- Heavy duty knurled sleeves are designed to resist brinneling and maximise performance under impulse conditions
- AG-Series couplers and nipples are available with a 'Ball' style valve or a 'Poppet' style valve



PERFORMANCE SPECIFICATIONS	OPERATING bar (psi)	MIN. BURST bar (psi)	FLOW RATE $\Delta P=2$ bar	LOCKING MECHANISM
1/4"	350 (5,075)	1300 (18,850)	12 LPM (3.2 GPM)	10 Balls
3/8"	300 (4,350)	1200 (17,400)	26 LPM (7 GPM)	10 Balls
1/2"	300 (4,350)	1160 (16,820)	45 LPM (12 GPM)	12 Balls
3/4"	250 (3,625)	1040 (15,080)	76 LPM (20 GPM)	12 Balls
1"	220 (3,190)	1000 (14,500)	151 LPM (40 GPM)	12 Balls

INTERCHANGE STANDARDS	US MILITARY	INDUSTRY STANDARDS	INTERNATIONAL STANDARDS	ANSI/NFPA
1/4"	---	---	ISO5675	---
3/8"	---	---	ISO5675	---
1/2"	---	---	ISO7241-A	---
3/4"	---	---	ISO5675	---
1"	---	---	ISO5675	---

'AG' SERIES INTERCHANGE	PARKER	FASTER	TOMCO	SAFEWAY
1/4"	4000 Series	NV series (1/2" only)	Series 'PC'	Series 'S20'
3/8"	4000 Series	NV series (1/2" only)	Series 'PC'	Series 'S20'
1/2"	4000 Series	NV series (1/2" only)	Series 'PC'	Series 'S20'
3/4"	4000 Series	NV series (1/2" only)	Series 'PC'	Series 'S20'
1"	4000 Series	NV series (1/2" only)	Series 'PC'	Series 'S20'



AG-SERIES AGRICULTURAL INTERCHANGE (COUPLER DUST PLUG)			
PART NO.	BODY SIZE	CAP LANYARD	BODY MATERIAL
2AGDP	1/4"	Elastomer	Elastomer
3AGDP	3/8"	Elastomer	Elastomer
4AGDP	1/2"	Elastomer	Elastomer
6AGDP	3/4"	Elastomer	Elastomer
8AGDP	1"	Elastomer	Elastomer



AG-SERIES AGRICULTURAL INTERCHANGE (NIPPLE DUST CAP)			
PART NO.	BODY SIZE	CAP LANYARD	BODY MATERIAL
AG2DC	1/4"	Elastomer	Elastomer
AG3DC	3/8"	Elastomer	Elastomer
AG4DC	1/2"	Elastomer	Elastomer
AG6DC	3/4"	Elastomer	Elastomer
AG8DC	1"	Elastomer	Elastomer

AG-SERIES AGRICULTURAL INTERCHANGE (COUPLER)



(Female Thread)

PART NO.	BODY SIZE	THREAD SIZE	BODY MATERIAL
2AGF2	1/4"	1/4"-18 NPTF	Steel
2AGF2-PV	1/4"	1/4"-18 NPTF	Steel
2AGOF3	1/4"	9/16"-18 ORB	Steel
2AGOF3-PV	1/4"	9/16"-18 ORB	Steel
3AGF3	3/8"	3/8"-18 NPTF	Steel
3AGF3-PV	3/8"	3/8"-18 NPTF	Steel
4AGF4	1/2"	1/2"-14 NPTF	Steel
4AGF4-PV	1/2"	1/2"-14 NPTF	Steel
4AGBF4	1/2"	1/2"-14 BSPP	Steel
4AGBF4-PV	1/2"	1/2"-14 BSPP	Steel
4AGOF4	1/2"	3/4"-16 ORB	Steel
4AGOF4-PV	1/2"	3/4"-16 ORB	Steel
4AGOF5	1/2"	7/8"-14 ORB	Steel
4AGOF5-PV	1/2"	7/8"-14 ORB	Steel
4AGF6	1/2"	3/4"-14 NPTF	Steel
4AGF6-PV	1/2"	3/4"-14 NPTF	Steel
4AGBF6	1/2"	3/4"-14 BSPP	Steel
4AGBF6-PV	1/2"	3/4"-14 BSPP	Steel
6AGF6	3/4"	3/4"-14 NPTF	Steel
6AGF6-PV	3/4"	3/4"-14 NPTF	Steel
8AGF8	1"	1"-11 1/2 NPTF	Steel
8AGF8-PV	1"	1"-11 1/2 NPTF	Steel



(Female Thread)

AG-SERIES AGRICULTURAL INTERCHANGE (PUSH-PULL COUPLER)

PART NO.	BODY SIZE	THREAD SIZE	BODY MATERIAL
4AGF4-PS	1/2"	1/2"-14 NPTF	Steel
4AGF4-PV-PS	1/2"	1/2"-14 NPTF	Steel



(Female Thread)

AG-SERIES AGRICULTURAL INTERCHANGE (NIPPLE)

PART NO.	BODY SIZE	THREAD SIZE	BODY MATERIAL
AG2F2	1/4"	1/4"-18 NPTF	Steel
AG2F2-PV	1/4"	1/4"-18 NPTF	Steel
AG2OF3	1/4"	9/16"-18 ORB	Steel
AG2OF3-PV	1/4"	9/16"-18 ORB	Steel
AG3F3	3/8"	3/8"-18 NPTF	Steel
AG3F3-PV	3/8"	3/8"-18 NPTF	Steel
AG4F4	1/2"	1/2"-14 NPTF	Steel
AG4F4-PV	1/2"	1/2"-14 NPTF	Steel
AG4BF4	1/2"	1/2"-14 BSPP	Steel
AG4BF4-PV	1/2"	1/2"-14 BSPP	Steel
AG4OF4	1/2"	3/4"-16 ORB	Steel
AG4OF4-PV	1/2"	3/4"-16 ORB	Steel
AG4OF5	1/2"	7/8"-14 ORB	Steel
AG4OF5-PV	1/2"	7/8"-14 ORB	Steel
AG4F6	1/2"	3/4"-14 NPTF	Steel
AG4F6-PV	1/2"	3/4"-14 NPTF	Steel
AG4BF6	1/2"	3/4"-14 BSPP	Steel
AG4BF6-PV	1/2"	3/4"-14 BSPP	Steel
AG6F6	3/4"	3/4"-14 NPTF	Steel
AG6F6-PV	3/4"	3/4"-14 NPTF	Steel
AG8F8	1"	1"-11 1/2 NPTF	Steel
AG8F8-PV	1"	1"-11 1/2 NPTF	Steel



Poppet Valve Style (-PV)



Standard Ball Valve Style

Dixon carries two valve styles for the Agricultural coupling series, 'Ball' valve and 'Poppet' valve. The 'Ball' valve coupling has historically provided greater longevity while the 'Poppet' valve will improve flow while in operation.

TR-Series TEMA European Interchange

- High performance design is fully interchangeable with TEMA/Rectus T-Series Problem Solvers
- Plated Steel couplers have an integrated safety lock-ring as a standard feature
- Dual O-ring sealing system ensures optimum seal integrity for high pressure, low pressure, and vacuum applications
- Nipple design provides added seal integrity by capturing the O-ring during connection and optimising compression



PERFORMANCE SPECIFICATIONS	OPERATING bar (psi)	MIN. BURST bar (psi)	FLOW RATE $\Delta P=2$ bar	LOCKING MECHANISM
3/8"	350 (5,075)	1,310 (19,000)	50 LPM (13 GPM)	9 Balls
1/2"	350 (5,075)	1,103 (16,000)	80 LPM (21 GPM)	9 Balls
3/4"	280 (4,060)	1,103 (16,000)	155 LPM (41 GPM)	9 Balls
1"	250 (3,625)	1,000 (14,500)	270 LPM (71 GPM)	9 Balls

INTERCHANGE STANDARDS	US MILITARY	INDUSTRY STANDARDS	INTERNATIONAL STANDARDS	ANSI/NFPA
3/8"	---	---	---	---
1/2"	---	---	---	---
3/4"	---	---	---	---
1"	---	---	---	---

'TR' SERIES INTERCHANGE	TEMA	CEJN	-	-
3/8"	3800	Series 525	---	---
1/2"	5000	Series 525	---	---
3/4"	7500	Series 525	---	---
1"	10000	Series 525	---	---

TR-SERIES TEMA EUROPEAN INTERCHANGE (COUPLER)



(Female Thread)

PART NO.	BODY SIZE	THREAD SIZE	BODY MATERIAL
3TRF3	3/8"	3/8"-18 NPTF	Steel
3TRBF3	3/8"	G3/8" BSPP	Steel
4TRF4	1/2"	1/2"-14 NPTF	Steel
4TRBF4	1/2"	G1/2" BSPP	Steel
6TRF6	3/4"	3/4"-14 NPTF	Steel
6TRBF6	3/4"	G3/4" BSPP	Steel
8TRF8	1"	1"-11 1/2 NPTF	Steel
8TRBF8	1"	G1" BSPP	Steel

TR-SERIES TEMA EUROPEAN INTERCHANGE (NIPPLE)



(Female Thread)

PART NO.	BODY SIZE	THREAD SIZE	BODY MATERIAL
TR3F3	3/8"	3/8"-18 NPTF	Steel
TR3BF3	3/8"	G3/8" BSPP	Steel
TR4F4	1/2"	1/2"-14 NPTF	Steel
TR4BF4	1/2"	G1/2" BSPP	Steel
TR6F6	3/4"	3/4"-14 NPTF	Steel
TR6BF6	3/4"	G3/4" BSPP	Steel
TR8F8	1"	1"-11 1/2 NPTF	Steel
TR8BF8	1"	G1" BSPP	Steel

VEP-Series Threaded Flushface

- Threaded flushface design will overcome typical coupling issues such as brinelling, side-load and premature seal failure due to impulse and surge conditions.
- Ideally suited for applications with high pressure impulses and system spikes, such as hydraulic hammer attachments
- Threaded sleeve allows connection against residual pressure
- Flushface design will prevent the loss of fluid during disconnection and air inclusion during connection
- Interchanges with Stucchi VEP Series



PERFORMANCE SPECIFICATIONS	OPERATING bar (psi)	COUPLED BURST bar (psi)	FLOW RATE $\Delta P=1$ bar	LOCKING MECHANISM
1/4"	600 (8700)	1,510 (22,000)	21 LPM (5.5 GPM)	Threaded
3/8"	552 (8000)	1,510 (22,000)	53 LPM (14 GPM)	Threaded
1/2"	552 (8000)	1,510 (22,000)	91 LPM (24 GPM)	Threaded
3/4"	552 (8000)	1,510 (22,000)	132 LPM (35 GPM)	Threaded
1"	503 (7300)	1,510 (22,000)	170 LPM (45 GPM)	Threaded
1 1/4"	483 (7000)	1,380(20,000)	265 LPM (70 GPM)	Threaded
1 1/2"	400 (5800)	1,100(16,000)	568 LPM (150 GPM)	Threaded
2"	351 (5100)	1,100(16,000)	908 LPM (240 GPM)	Threaded

Please note: Performance Data is for guidance only and is based upon lab tests and simulations. Subject to change.

VEP-SERIES THREADED FLUSHFACE INTERCHANGE (COUPLER)



(Female Thread)

PART NO.	PART NO.	BODY SIZE	BODY MATERIAL
2VEPF2	2VEPBF2	1/4"	Steel
3VEPF3	3VEPBF3	3/8"	Steel
4VEPF4	4VEPBF4	1/2"	Steel
6VEPF6	6VEPBF6	3/4"	Steel
8VEPF8	8VEPBF8	1"	Steel
10VEPF10	10VEPBF10	1 1/4"	Steel
12VEPF12	12VEPBF12	1 1/2"	Steel
16VEPF16	16VEPBF16	2"	Steel

VEP-SERIES THREADED FLUSHFACE INTERCHANGE (NIPPLE)



(Female Thread)

PART NO.	PART NO.	BODY SIZE	BODY MATERIAL
VEP2F2	VEP2BF2	1/4"	Steel
VEP3F3	VEP3BF3	3/8"	Steel
VEP4F4	VEP4BF4	1/2"	Steel
VEP6F6	VEP6BF6	3/4"	Steel
VEP8F8	VEP8BF8	1"	Steel
VEP10F10	VEP10BF10	1 1/4"	Steel
VEP12F12	VEP12BF12	1 1/2"	Steel
VEP16F16	VEP16BF16	2"	Steel

W Series Wing Style Interchange

- Threaded wing or hex sleeves enable easy connection and disconnection while under pressure
- O-ring “connected” marker is highly visible during connection and helps to keep contaminants out of the threads while connected
- Coupler has a high flow tubular valve that is designed to reduce pressure drop and turbulence, while improving flow performance
- Bulkhead mounting kits are available to secure the nipples for simplified connection and disconnection
- Flanged bonded seal prolongs coupling life while being integral in the reduction of spillage and air inclusion



PERFORMANCE SPECIFICATIONS	OPERATING bar (psi)	MIN. BURST bar (psi)	FLOW RATE $\Delta P=2$ bar	LOCKING MECHANISM
3/4"	207 (3,000)	621 (9,000)	132 LPM (35 GPM)	Threaded
1"	207 (3,000)	621 (9,000)	208 LPM (55 GPM)	Threaded
1 1/4"	190 (2,750)	569 (8,250)	303 LPM (80 GPM)	Threaded
1 1/2"	172 (2,500)	517 (7,500)	416 LPM (110 GPM)	Threaded

'W' SERIES INTERCHANGE	PARKER	AEROQUIP	SNAP-TITE	FASTER
3/4"	6100 Series	621 (9,000)	132 LPM (35 GPM)	Threaded
1"	6100 Series	621 (9,000)	208 LPM (55 GPM)	Threaded
1 1/4"	6100 Series	569 (8,250)	303 LPM (80 GPM)	Threaded
1 1/2"	6100 Series	517 (7,500)	416 LPM (110 GPM)	Threaded



W-SERIES THREAD-TOGETHER INTERCHANGE (COUPLER RIGID DUST PLUG)

PART NO.	BODY SIZE	CAP LANYARD	BODY MATERIAL
6WDP-B	3/4"	Steel Chain	Brass
8WDP-B	1"	Steel Chain	Brass
10WDP-B	1 1/4"	Steel Chain	Brass
12WDP-B	1 1/2"	Steel Chain	Brass



W-SERIES THREAD-TOGETHER INTERCHANGE (NIPPLE RIGID DUST CAP)

PART NO.	BODY SIZE	CAP LANYARD	BODY MATERIAL
W6DC-B	3/4"	Steel Chain	Brass
W8DC-B	1"	Steel Chain	Brass
W10DC-B	1 1/4"	Steel Chain	Brass
W12DC-B	1 1/2"	Steel Chain	Brass



W-SERIES THREAD-TOGETHER INTERCHANGE (MOUNTING FLANGE)

PART NO.	BODY SIZE	BOLT HOLE-SIZE	BODY MATERIAL
W6-BMF	3/4"	1/4"	Steel
W8-BMF	1"	1/4"	Steel
W10-BMF	1 1/4"	1/4"	Steel
W12-BMF	1 1/2"	3/8"	Steel



(Female Thread)

W-SERIES THREAD-TOGETHER INTERCHANGE (WING-NUT COUPLER)

PART NO.	BODY SIZE	THREAD SIZE	BODY MATERIAL
6WBF4-B	3/4"	1/2" BSPP	Brass
6WBF6-B	3/4"	3/4" BSPP	Brass
8WBF8-B	1"	1" BSPP	Brass
10WBF10-B	1 1/4"	1 1/4" BSPP	Brass
12WBF12-B	1 1/2"	1 1/2" BSPP	Brass
6WF4-B	3/4"	1/2" NPTF	Brass
6WF6-B	3/4"	3/4" NPTF	Brass
8WF8-B	1"	1" NPTF	Brass
8WF8	1"	1-11 1/2 NPTF	Steel
10WF10-B	1 1/4"	1 1/4" NPTF	Brass
12WF12-B	1 1/2"	1 1/2" NPTF	Brass

W-SERIES THREAD-TOGETHER INTERCHANGE (HEX-NUT COUPLER)



(Female Thread)

PART NO.	BODY SIZE	THREAD SIZE	BODY MATERIAL
6WBF4-B-HN	3/4"	1/2" BSPP	Brass
6WBF6-B-HN	3/4"	3/4" BSPP	Brass
8WBF8-B-HN	1"	1" BSPP	Brass
10WBF10-B-HN	1 1/4"	1 1/4" BSPP	Brass
12WBF12-B-HN	1 1/2"	1 1/2" BSPP	Brass
6WF4-B-HN	3/4"	1/2" NPTF	Brass
6WF6-B-HN	3/4"	3/4" NPTF	Brass
8WF8-B-HN	1"	1" NPTF	Brass
10WF10-B-HN	1 1/4"	1 1/4" NPTF	Brass
12WF12-B-HN	1 1/2"	1 1/2" NPTF	Brass

W-SERIES THREAD-TOGETHER INTERCHANGE (NIPPLE)



(Male Thread)

PART NO.	BODY SIZE	THREAD SIZE	BODY MATERIAL
W6BF4-B	3/4"	1/2" BSPP	Brass
W6BF6-B	3/4"	3/4" BSPP	Brass
W8BF8-B	1"	1" BSPP	Brass
W10BF10-B	1 1/4"	1 1/4" BSPP	Brass
W12BF12-B	1 1/2"	1 1/2" BSPP	Brass
W6F4-B	3/4"	1/2" NPTF	Brass
W6F6-B	3/4"	3/4" NPTF	Brass
W8F8-B	1"	1" NPTF	Brass
W8F8	1"	1-11 1/2 NPTF	Steel
W10F10-B	1 1/4"	1 1/4" NPTF	Brass
W12F12-B	1 1/2"	1 1/2" NPTF	Brass

W-SERIES THREAD-TOGETHER INTERCHANGE (NIPPLE WITH FLANGE)



PART NO.	BODY SIZE	THREAD SIZE	BODY MATERIAL
W6F4-B-BMF	3/4"	1/2"-14 NPTF	Brass
W6BF4-B-BMF	3/4"	G1/2" BSPP	Brass
W6F6-B-BMF	3/4"	3/4"-14 NPTF	Brass
W6BF6-B-BMF	3/4"	G3/4" BSPP	Brass
W8F8-B-BMF	1"	1"-11 1/2 NPTF	Brass
W8BF8-B-BMF	1"	G1" BSPP	Brass
W10F10-B-BMF	1 1/4"	1 1/4"-11 1/2 NPTF	Brass
W10BF10-B-BMF	1 1/4"	G1 1/4" BSPP	Brass
W12F12-B-BMF	1 1/2"	1 1/2"-11 1/2 NPTF	Brass
W12BF12-B-BMF	1 1/2"	G1 1/2" BSPP	Brass

HT-Series ISO16028 Flushface Interchange

Interchange Data:

- Interchangeable to ISO 16028
- Parker FEM-Series, Snap-Tite 74-Series, Aeroquip/Eaton FD89, Safeway FF49-Series
- Hansen FF, Stucchi FIRG/Series 'A', Faster FFF/2FFI/2FFN/2FFH, Cjen X65 Series, Holmbury Flat Face ISO 16028, Rectus/Tema - IF Series

Materials:

- Machined components are manufactured using solid steel or 316 stainless steel bar stock
- Stainless steel balls, retaining rings, and springs maximize corrosion resistance and extend service life
- Steel components are plated using ROHS compliant trivalent chrome
- Steel coupler sleeves are hardened to resist deformation and maximize service life
- Steel nipples are hardened to provide resistance to brinelling during impulse service

Seal Components:

- 1/4" to 3/4" nipples have moulded Polyurethane valve seals, with a temperature range of -54°C to +100°C (-65°F to +212°F)
- 1" nipples have nitrile-energised PTFE valve seals, with a temperature range of -40°C to +121°C (-40°F to +250°F)
- Couplers have a polyurethane valve stem O-Ring, with a temperature range of -54°C to +100°C (-65°F to +212°F)
- Ancillary coupler and nipple seals are Nitrile (Buna-N), temperature range of -40°C to +121°C (-40°F to +250°F)
- PTFE anti-extrusion ring protects main coupling valve seal from dynamic impulse pressure damage



Body Size	PERFORMANCE SPECIFICATION: HT-SERIES ISO 16028 FLUSHFACE															
	Steel Coupler / Plug Coupled				316SS Coupler / Plug Coupled				Steel Coupler Uncoupled				Steel Plug Uncoupled			
	Max. Working		Burst		Max. Working		Burst		Max. Working		Burst		Max. Working		Burst	
	PSI	Bar	PSI	Bar	PSI	Bar	PSI	Bar	PSI	Bar	PSI	Bar	PSI	Bar	PSI	Bar
1/4"	4,575	316	18,300	1,262	-	-	-	-	4,575	316	18,300	1,262	4,575	316	18,300	1,262
3/8"	4,375	302	17,500	1,207	3,500	241	17,500	1,207	4,375	302	17,500	1,207	4,375	302	17,500	1,207
1/2"	4,250	293	17,000	1,172	3,400	234	17,000	1,172	4,250	293	17,000	1,172	4,250	293	17,000	1,172
5/8"	3,650	252	14,600	1,007	2,920	201	14,600	1,007	3,650	252	14,600	1,007	3,650	252	14,600	1,007
3/4"	3,650	252	14,600	1,007	2,920	201	14,600	1,007	3,650	252	14,600	1,007	3,650	252	14,600	1,007
1"	3,650	252	14,600	1,007	2,920	201	14,600	1,007	3,650	252	14,600	1,007	3,650	252	14,600	1,007

'HT' SERIES INTERCHANGE	PARKER	SNAP-TITE	FASTER	HOLMBURY
3/8"	FF-Series	74 Series	FFN/2FFN/2FFI	Series 'A'
1/4"	FE-Series	74 Series	FFI/2FFI/3FFI	Series 'A'
1/2"	FE-Series	74 Series	FFI/2FFI/3FFI	Series 'A'
5/8"	FE-Series	74 Series	FFI/2FFI/3FFI	Series 'A'
3/4"	FE-Series	74 Series	FFI/2FFI/3FFI	Series 'A'
1"	-	74 Series	FFI/2FFI/3FFI	Series 'A'



Note: Fits Dixon/Perfecting couplers only

HT-SERIES ISO16028 FLUSHFACE INTERCHANGE (COUPLER DUST CAP)			
PART NO.	BODY SIZE	CAP LANYARD	BODY MATERIAL
3HTDP	3/8"	Elastomer	Elastomer
4HTDP	1/2"	Elastomer	Elastomer
5HTDP	5/8"	Elastomer	Elastomer
6HTDP	3/4"	Elastomer	Elastomer
8HTDP	1"	Elastomer	Elastomer



Note: Fits all ISO 16018 nipples

HT-SERIES ISO16028 FLUSHFACE INTERCHANGE (NIPPLE DUST CAP)			
PART NO.	BODY SIZE	CAP LANYARD	BODY MATERIAL
HT3DC	3/8"	Elastomer	Elastomer
HT4DC	1/2"	Elastomer	Elastomer
HT5DC	5/8"	Elastomer	Elastomer
HT6DC	3/4"	Elastomer	Elastomer
HT8DC	1"	Elastomer	Elastomer

HT-SERIES ISO16028 FLUSHFACE INTERCHANGE (COUPLER)

PART NO.	BODY SIZE	THREAD SIZE	BODY MATERIAL
2HTF2	1/4"	1/4"-18NPTF	Steel
2HTBF2	1/4"	1/4"-19BSPP	Steel
3HTF3	3/8"	3/8"-18 NPTF	Steel
3HTF3-SS	3/8"	3/8"-18 NPTF	316 Stainless Steel
3HTOF3	3/8"	9/16-18 ORB	Steel
3HTBF3	3/8"	G3/8"BSPP	Steel
3HTBF3-SS	3/8"	G3/8"BSPP	316 Stainless Steel
3HTF4	3/8"	1/2-14 NPTF	Steel
3HTF4-SS	3/8"	1/2-14 NPTF	316 Stainless Steel
3HTOF4	3/8"	3/4"-16 ORB	Steel
3HTBF4	3/8"	G1/2" BSPP	Steel
3HTBF4-SS	3/8"	G1/2" BSPP	316 Stainless Steel
4HTF4	1/2"	1/2"-14 NPTF	Steel
4HTF4-SS	1/2"	1/2"-14 NPTF	316 Stainless Steel
4HTOF4	1/2"	3/4"-16 ORB	Steel
4HTBF4	1/2"	G1/2" BSPP	Steel
4HTBF4-SS	1/2"	G1/2" BSPP	316 Stainless Steel
4HTOF5	1/2"	7/8"-14 ORB	Steel
4HTF6	1/2"	3/4"-14 NPTF	Steel
4HTF6-SS	1/2"	3/4"-14 NPTF	316 Stainless Steel
4HTOF6	1/2"	1 1/16"-12 ORB	Steel
4HTBF6	1/2"	G3/4" BSPP	Steel
4HTBF6-SS	1/2"	G3/4" BSPP	316 Stainless Steel
5HTOF5	5/8"	7/8"-14 ORB	Steel
5HTF6	5/8"	3/4"-14 NPTF	Steel
5HTF6-SS	5/8"	3/4"-14 NPTF	316 Stainless Steel
5HTOF6	5/8"	1 1/16"-12 ORB	Steel
5HTBF6	5/8"	G3/4" BSPP	Steel
5HTBF6-SS	5/8"	G3/4" BSPP	316 Stainless Steel
6HTOF5	3/4"	7/8"-14 ORB	Steel
6HTF6	3/4"	3/4"-14 NPTF	Steel
6HTF6-SS	3/4"	3/4"-14 NPTF	316 Stainless Steel
6HTOF6	3/4"	1 1/16"-12 ORB	Steel
6HTBF6	3/4"	G3/4" BSPP	Steel
6HTBF6-SS	3/4"	G3/4" BSPP	316 Stainless Steel
6HTF8	3/4"	1"-1 1/2 NPTF	Steel
6HTF8-SS	3/4"	1"-1 1/2 NPTF	316 Stainless Steel
6HTOF8	3/4"	1 5/16"-12 ORB	Steel
6HTBF8	3/4"	G1" BSPP	Steel
6HTBF8-SS	3/4"	G1" BSPP	316 Stainless Steel
8HTF8	1"	1"-1 1/2 NPTF	Steel
8HTF8-SS	1"	1"-1 1/2 NPTF	316 Stainless Steel
8HTOF8	1"	1 5/16"-12 ORB	Steel
8HTBF8	1"	G1" BSPP	Steel
8HTBF8-SS	1"	G1" BSPP	316 Stainless Steel
8HTF10	1"	1 1/4"-1 1/2 NPTF	Steel
8HTF10-SS	1"	1 1/4"-1 1/2 NPTF	316 Stainless Steel
8HTOF10	1"	1 5/8"-12 ORB	Steel
8HTBF10	1"	G1 1/4" BSPP	Steel
8HTBF10-SS	1"	G1 1/4" BSPP	316 Stainless Steel



(Female Thread)

HT SERIES ISO16028 FLUSHFACE INTERCHANGE (COUPLER)

PART NO.	BODY SIZE	THREAD SIZE	BODY MATERIAL
3HTM3	3/8"	3/8"-18 NPTF	Steel
3HTM4	3/8"	1/2"-14 NPTF	Steel
3HTOM4	3/8"	3/4"-16 ORB	Steel
4HTJB5	1/2"	7/8"-14 JIC BH	Steel
4HTRB5	1/2"	1"-14 ORFS BH	Steel
4HTJB6	1/2"	1 1/6"-12 JIC BH	Steel



(Male Thread)

IMPORTANT

Although a special lubricant is used to protect the flushface seals during pre-service storage, the seals are still vulnerable until they are exposed to the system fluid. It is recommended to lubricate the seals before the first connection by placing a drop of oil into the main valve grooves on the face of the nipple.

Quick Release Couplings

HT-SERIES ISO16028 FLUSHFACE INTERCHANGE (NIPPLE)

PART NO.	BODY SIZE	THREAD SIZE	BODY MATERIAL
HT2F2	1/4"	1/4"-18 NPTF	Steel
HT2BF2	1/4"	1/4"-19 BSPP	Steel
HT3F3	3/8"	3/8"-18 NPTF	Steel
HT3F3-SS	3/8"	3/8"-18 NPTF	316 Stainless Steel
HT3OF3	3/8"	9/16"-18 ORB	Steel
HT3BF3	3/8"	G3/8" BSPP	Steel
HT3BF3-SS	3/8"	G3/8" BSPP	316 Stainless Steel
HT3F4	3/8"	1/2"-14 NPTF	Steel
HT3F4-SS	3/8"	1/2"-14 NPTF	316 Stainless Steel
HT3OF4	3/8"	3/4"-16 ORB	Steel
HT3BF4	3/8"	G1/2" BSPP	Steel
HT3BF4-SS	3/8"	G1/2" BSPP	316 Stainless Steel
HT4F4	1/2"	1/2"-14 NPTF	Steel
HT4F4-SS	1/2"	1/2"-14 NPTF	316 Stainless Steel
HT4OF4	1/2"	3/4"-16 ORB	Steel
HT4BF4	1/2"	G1/2" BSPP	Steel
HT4BF4-SS	1/2"	G1/2" BSPP	316 Stainless Steel
HT4OF5	1/2"	7/8"-14 ORB	Steel
HT4F6	1/2"	3/4"-14 NPTF	Steel
HT4F6-SS	1/2"	3/4"-14 NPTF	316 Stainless Steel
HT4OF6	1/2"	1 1/16"-12 ORB	Steel
HT4BF6	1/2"	G3/4" BSPP	Steel
HT4BF6-SS	1/2"	G3/4" BSPP	316 Stainless Steel
HT5OF5	5/8"	7/8"-14 ORB	Steel
HT5F6	5/8"	3/4"-14 NPTF	Steel
HT5F6-SS	5/8"	3/4"-14 NPTF	316 Stainless Steel
HT5OF6	5/8"	1 1/16"-12 ORB	Steel
HT5BF6	5/8"	G3/4" BSPP	Steel
HT5BF6-SS	5/8"	G3/4" BSPP	316 Stainless Steel
HT6OF5	3/4"	7/8"-14 ORB	Steel
HT6F6	3/4"	3/4"-14 NPTF	Steel
HT6F6-SS	3/4"	3/4"-14 NPTF	316 Stainless Steel
HT6OF6	3/4"	1 1/16"-12 ORB	Steel
HT6BF6	3/4"	G3/4" BSPP	Steel
HT6BF6-SS	3/4"	G3/4" BSPP	316 Stainless Steel
HT6F8	3/4"	1" -11 1/2 NPTF	Steel
HT6F8-SS	3/4"	1" -11 1/2 NPTF	316 Stainless Steel
HT6F8	3/4"	15/16"-12 ORB	Steel
HT6BF8	3/4"	G1" BSPP	Steel
HT6BF8-SS	3/4"	G1" BSPP	316 Stainless Steel
HT8F8	1"	1"-11 1/2 NPTF	Steel
HT8F8-SS	1"	1"-11 1/2 NPTF	316 Stainless Steel
HT8OF8	1"	15/16"-12 ORB	Steel
HT8BF8	1"	G1" BSPP	Steel
HT8BF8-SS	1"	G1" BSPP	316 Stainless Steel
HT8F10	1"	1 1/4"-11 1/2 NPTF	Steel
HT8F10-SS	1"	1 1/4"-11 1/2 NPTF	316 Stainless Steel
HT8OF10	1"	15/8"-12 ORB	Steel
HT8BF10	1"	G1 1/4" BSPP	Steel
HT8BF10-SS	1"	G1 1/4" BSPP	316 Stainless Steel



(Female Thread)



(Male Thread)

HT-SERIES ISO16028 FLUSHFACE INTERCHANGE (NIPPLE)

PART NO.	BODY SIZE	THREAD SIZE	BODY MATERIAL
HT3M3	3/8"	3/8"-18 NPTF	Steel
HT3M4	3/8"	1/2"-14 NPTF	Steel
HT3OM4	3/8"	3/4"-16 ORB	Steel
HT4JB5	1/2"	7/8"-14 JIC BH	Steel
HT4RB5	1/2"	1"-14 ORFS BH	Steel
HT4JB6	1/2"	1 1/6"-12 JIC BH	Steel

IMPORTANT

Although a special lubricant is used to protect the flushface seals during pre-service storage, the seals are still vulnerable until they are exposed to the system fluid. It is recommended to lubricate the seals before the first connection by placing a drop of oil into the main valve grooves on the face of the nipple.

ST-Series Snap-Tite '71' Interchange

- Flush face design minimises air inclusion during connection and fluid loss during disconnection
- Heavy duty grooved sleeves provide bulkhead mounting options and reduce instances of brinelling
- Designed to exceed 1,000,000 cycles during impulse pressure conditions
- ST-Series couplings comply with applicable Det Norske Veritas North Sea standards for coupling applications
- Available in a wide variety of materials, including high pressure stainless steel configurations upon request



PERFORMANCE SPECIFICATIONS	OPERATING bar (psi)	BURST bar (psi)	FLOW RATE $\Delta P=1$ bar	LOCKING MECHANISM
3/4"	586 (8,500)	1,172 (17,000)	138 LPM (36 GPM)	12 Balls
1"	552 (8,000)	1,103 (16,000)	189 LPM (50 GPM)	12 Balls
2"	448 (6,500)	897 (13,000)	757 LPM (200 GPM)	12 Balls
3/4" 316 SS	345 (5,000)	865 (12,500)	138 LPM (36 GPM)	12 Balls
1" 316 SS	280 (4,000)	690 (10,000)	189 LPM (50 GPM)	12 Balls
2" 316 SS	210 (3,000)	415 (6,000)	757 LPM (200 GPM)	12 Balls

Please note: Minimum burst pressure ratings were established under laboratory conditions using a Static Burst Unit (SBU). For high impulse applications and to meet Det Norske Veritas (DNV) compliance, the burst pressure must be divided by four (4) to ensure a 4:1 safety factor during system operation. For 316 Stainless Steel operating pressure multiply the operating pressures above by 0.60.

INTERCHANGE GUIDE	SNAP-TITE 71-3	PCL 71FF	-	-
3/4"	Series 71-3	71FF	-	-
1"	Series 71-3	71FF	-	-
2"	Series 71-3	71FF	-	-



ST-SERIES SNAP-TITE '71' INTERCHANGE (COUPLER RIGID DUST CAP)

PART NO.	BODY SIZE	CAP LANYARD	BODY MATERIAL
6STDP-A	3/4"	Steel Chain	Aluminium
8STDP-A	1"	Steel Chain	Aluminium
16STDP-A	2"	Steel Chain	Aluminium



ST-SERIES SNAP-TITE '71' INTERCHANGE (NIPPLE RIGID DUST CAP)

PART NO.	BODY SIZE	CAP LANYARD	BODY MATERIAL
ST6DC-A	3/4"	Steel Chain	Aluminium
ST8DC-A	1"	Steel Chain	Aluminium
ST16DC-A	2"	Steel Chain	Aluminium

ST-SERIES SNAP-TITE '71' INTERCHANGE (AUTOMATIC COUPLER)



(Female Thread)

PART NO.	BODY SIZE	THREAD SIZE	BODY MATERIAL
2STF2	1/4"	1/4"- 18 NPTF	Steel
2STF2-SS	1/4"	1/4"- 18 NPTF	316 Stainless Steel
2STBF2	1/4"	1/4"- 19 BSPP	Steel
2STBF2-SS	1/4"	1/4"- 19 BSPP	316 Stainless Steel
3STF2	3/8"	1/4"- 18 NPTF	Steel
3STF3	3/8"	3/8"- 18 NPTF	Steel
3STF3-SS	3/8"	3/8"- 18 NPTF	316 Stainless Steel
3STBF3	3/8"	3/8"- 19 BSPP	Steel
3STBF3-SS	3/8"	3/8"- 19 BSPP	316 Stainless Steel
3STF4	3/8"	1/2"- 14 NPTF	Steel
3STF4-SS	3/8"	1/2"- 14 NPTF	316 Stainless Steel
3STBF4	3/8"	1/2"- 14 BSPP	Steel
3STBF4-SS	3/8"	1/2"- 14 BSPP	316 Stainless Steel
4STF4	1/2"	1/2"- 14 NPTF	Steel
4STF4-SS	1/2"	1/2"- 14 NPTF	316 Stainless Steel
4STBF4	1/2"	1/2"- 14 BSPP	Steel
4STBF4-SS	1/2"	1/2"- 14 BSPP	316 Stainless Steel
4STOF4	1/2"	3/4"-16 ORB	Steel
6STF6	3/4"	3/4"-14 NPTF	Steel
6STF6-SS	3/4"	3/4"-14 NPTF	316 Stainless Steel
6STOF6	3/4"	1 1/16"-12 ORB	Steel
6STOF6-SS	3/4"	1 1/16"-12 ORB	316 Stainless Steel
6STBF6	3/4"	G 3/4" BSPP	Steel
6STBF6-SS	3/4"	G 3/4" BSPP	316 Stainless Steel
8STF8	1"	1"-11 1/2 NPTF	Steel
8STF8-SS	1"	1"-11 1/2 NPTF	316 Stainless Steel
8STOF8	1"	1 5/16"-12 ORB	Steel
8STOF8-SS	1"	1 5/16"-12 ORB	316 Stainless Steel
8STBF8	1"	G1" BSPP	Steel
8STBF8-SS	1"	G1" BSPP	316 Stainless Steel
8STF10	1"	1 1/4"-11 1/2 NPTF	Steel
8STF10-SS	1"	1 1/4"-11 1/2 NPTF	316 Stainless Steel
8STOF10	1"	1 5/8"-12 ORB	Steel
8STOF10-SS	1"	1 5/8"-12 ORB	316 Stainless Steel
8STBF10	1"	G1 1/4" BSPP	Steel
8STBF10-SS	1"	G1 1/4" BSPP	316 Stainless Steel

ST-SERIES SNAP-TITE '71' INTERCHANGE (NIPPLE)

PART NO.	BODY SIZE	THREAD SIZE	BODY MATERIAL
ST2F2	1/4"	1/4"- 18 NPTF	Steel
ST2F2-SS	1/4"	1/4"- 18 NPTF	316 Stainless Steel
ST2BF2	1/4"	1/4"- 19 BSPP	Steel
ST2BF2-SS	1/4"	1/4"- 19 BSPP	316 Stainless Steel
ST3F2	3/8"	1/4"- 18 NPTF	Steel
ST3F3	3/8"	3/8"- 18 NPTF	Steel
ST3F3-SS	3/8"	3/8"- 18 NPTF	316 Stainless Steel
ST3BF3	3/8"	3/8"- 19 BSPP	Steel
ST3BF3-SS	3/8"	3/8"- 19 BSPP	316 Stainless Steel
ST3F4	3/8"	1/2"- 14 NPTF	Steel
ST3F4-SS	3/8"	1/2"- 14 NPTF	316 Stainless Steel
ST3BF4	3/8"	1/2"- 14 BSPP	Steel
ST3BF4-SS	3/8"	1/2"- 14 BSPP	316 Stainless Steel
ST4F4	1/2"	1/2"- 14 NPTF	Steel
ST4F4-SS	1/2"	1/2"- 14 NPTF	316 Stainless Steel
ST4BF4	1/2"	1/2"- 14 BSPP	Steel
ST4BF4-SS	1/2"	1/2"- 14 BSPP	316 Stainless Steel
ST4OF4	1/2"	3/4"-16 ORB	Steel
ST6F6	3/4"	3/4"-14 NPTF	Steel
ST6F6-SS	3/4"	3/4"-14 NPTF	316 Stainless Steel
ST60F6	3/4"	1 1/16"-12 ORB	Steel
ST60F6-SS	3/4"	1 1/16"-12 ORB	316 Stainless Steel
ST6BF6	3/4"	G3/4"BSPP	Steel
ST6BF6-SS	3/4"	G3/4"BSPP	316 Stainless Steel
ST8F8	1"	1"-11 1/2 NPTF	Steel
ST8F8-SS	1"	1"-11 1/2 NPTF	316 Stainless Steel
ST8OF8	1"	1 5/16"-12 ORB	Steel
ST8OF8-SS	1"	1 5/16"-12 ORB	316 Stainless Steel
ST8BF8	1"	G1" BSPP	Steel
ST8BF8-SS	1"	G1" BSPP	316 Stainless Steel
ST8F10	1"	1 1/4"-11 1/2 NPTF	Steel
ST8F10-SS	1"	1 1/4"-11 1/2 NPTF	316 Stainless Steel
ST8OF10	1"	1 5/8"-12 ORB	Steel
ST8OF10-SS	1"	1 5/8"-12 ORB	316 Stainless Steel
ST8BF10	1"	G1 1/4" BSPP	Steel
ST8BF10-SS	1"	G1 1/4" BSPP	316 Stainless Steel



(Female Thread)

ST-SERIES SNAP-TITE '71 OLD-STYLE' INTERCHANGE (AUTOMATIC COUPLER)

PART NO.	BODY SIZE	THREAD SIZE	BODY MATERIAL
8STF8-V2	1"	1"-11 1/2" NPTF	Steel
8STBF8-V	1"	G1" BSPP	Steel
16STF12	2"	1 1/2"-11 1/2" NPTF	Steel
16STOF12	2"	1 7/8"-12" ORB	Steel
16STBF12	2"	G1 1/4" BSPP	Steel
16STF16	2"	2"-11 1/2" NPTF	Steel
16STF16-SS	2"	2"-11 1/2" NPTF	316 Stainless Steel
16STOF16	2"	2 1/2"-12" ORB	Steel
16STBF16	2"	G2" BSPP	Steel



(Female Thread)

ST-SERIES SNAP-TITE '71 OLD-STYLE' INTERCHANGE (NIPPLE)

PART NO.	BODY SIZE	THREAD SIZE	BODY MATERIAL
ST8F8-V2	1"	1"-11 1/2 NPTF	Steel
ST8BF8-V	1"	G1" BSPP	Steel
ST16F12	2"	1 1/2"-11 1/2" NPTF	Steel
ST16OF12	2"	1 7/8"-12" ORB	Steel
ST16BF12	2"	G1 1/4" BSPP	Steel
ST16F16	2"	2"-11 1/2" NPTF	Steel
ST16F16-SS	2"	2"-11 1/2" NPTF	316 Stainless Steel
ST16OF16	2"	2 1/2"-12" ORB	Steel
ST16BF16	2"	G2" BSPP	Steel



(Female Thread)

WS-Series High Pressure Wing Style

- Sleeve is cast using a unique process that provides better surface finishes, tighter tolerance control and excellent repeatability
- Heavy duty hammer lugs are designed to provide optimum durability during connection and disconnection
- Seals are easily field replaceable, including the valve seal, which can be replaced without having to replace the entire valve
- WS-Series couplings comply with applicable Det Norske Veritas North Sea standards for coupling applications
- Unique 'Initial-Thread' profile will ensure nipple longevity in the toughest environments



PERFORMANCE SPECIFICATIONS	OPERATING bar (psi)	COUPLED BURST bar (psi)	FLOW RATE ΔP=2 bar	LOCKING MECHANISM
3/4" Steel	345 (5,000)	1,380 (20,000)	151 LPM (40 GPM)	Threaded
1" Steel	345 (5,000)	1,380 (20,000)	227 LPM (60 GPM)	Threaded
1 1/4" Steel	345 (5,000)	1,035 (15,000)	310 LPM (82 GPM)	Threaded
1 1/2" Steel	345 (5,000)	1,035 (15,000)	416 LPM (110 GPM)	Threaded
2" Steel	345 (5,000)	1,035 (15,000)	908 LPM (240 GPM)	Threaded

Please Note: To calculate the working pressure of 316SS parts, multiply the above Operating Pressures by 0.35

'WS' SERIES INTERCHANGE	SNAP-TITE	HYDRAULICS INC.	-	-
3/4"	75-Series	Series 5TV	-	-
1"	75-Series	Series 5TV	-	-
1 1/4"	75-Series	Series 5TV	-	-
1 1/2"	75-Series	Series 5TV	-	-
2"	75-Series	Series 5TV	-	-



WS-SERIES HIGH PRESSURE WING STYLE (COUPLER RIGID DUST PLUG)

PART NO.	BODY SIZE	CAP LANYARD	BODY MATERIAL
6WSDP-A	3/4"	Steel chain	Aluminium
8WSDP-A	1"	Steel chain	Aluminium
10WSDP-A	1 1/4"	Steel chain	Aluminium
12WSDP-A	1 1/2"	Steel chain	Aluminium
16WSDP-A	2"	Steel chain	Aluminium



WS-SERIES HIGH PRESSURE WING STYLE (NIPPLE RIGID DUST CAP)

PART NO.	BODY SIZE	CAP LANYARD	BODY MATERIAL
WS6DC-A	3/4"	Steel chain	Aluminium
WS8DC-A	1"	Steel chain	Aluminium
WS10DC-A	1 1/4"	Steel chain	Aluminium
WS12DC-A	1 1/2"	Steel chain	Aluminium
WS16DC-A	2"	Steel chain	Aluminium

Note: Wrench flats are not machined onto couplings. If you require wrench flats on couplings designate with a '-WF' suffix, please contact Dixon.

WS-SERIES HIGH PRESSURE WING STYLE (COUPLER)



(Female Thread)

Wrench flats are pictured,
non-flat fittings are standard

PART NO.	BODY SIZE	THREAD SIZE	BODY MATERIAL
6WSF6	3/4"	3/4"-14 NPTF	Steel
6WSF6-SS *	3/4"	3/4"-14 NPTF	316 SS
6WSBF6	3/4"	G3/4" BSPP	Steel
8WSF8	1"	1"-11 1/2 NPTF	Steel
8WSF8-SS *	1"	1"-11 1/2 NPTF	316 SS
8WSBF8	1"	G1" BSPP	Steel
10WSF10	1 1/4"	1 1/4"-11 1/2 NPTF	Steel
10WSF10-SS *	1 1/4"	1 1/4"-11 1/2 NPTF	316 SS
10WSBF10	1 1/4"	G1 1/4" BSPP	Steel
12WSF12	1 1/2"	1 1/2"-11 1/2 NPTF	Steel
12WSF12-SS *	1 1/2"	1 1/2"-11 1/2 NPTF	316 SS
12WSBF12	1 1/2"	G1 1/2" BSPP	Steel
16WSF16	2"	2"-11 1/2 NPTF	Steel
16WSF16-SS *	2"	2"-11 1/2 NPTF	316 SS
16WSBF16	2"	G2" BSPP	Steel

WS-SERIES HIGH PRESSURE WING STYLE (NIPPLE)



(Female Thread)

Wrench flats are pictured,
non-flat fittings are standard

PART NO.	BODY SIZE	THREAD SIZE	BODY MATERIAL
WS6F6	3/4"	3/4"-14 NPTF	Steel
WS6F6-SS *	3/4"	3/4"-14 NPTF	316 SS
WS6BF6	3/4"	G3/4" BSPP	Steel
WS8F8	1"	1"-11 1/2 NPTF	Steel
WS8F8-SS *	1"	1"-11 1/2 NPTF	316 SS
WS8BF8	1"	G1" BSPP	Steel
WS10F10	1 1/4"	1 1/4"-11 1/2 NPTF	Steel
WS10F10-SS *	1 1/4"	1 1/4"-11 1/2 NPTF	316 SS
WS10BF10	1 1/4"	G1 1/4" BSPP	Steel
WS12F12	1 1/2"	1 1/2"-11 1/2 NPTF	Steel
WS12F12-SS *	1 1/2"	1 1/2"-11 1/2 NPTF	316 SS
WS12BF12	1 1/2"	G1 1/2" BSPP	Steel
WS16F16	2"	2"-11 1/2 NPTF	Steel
WS16F16-SS *	2"	2"-11 1/2 NPTF	316 SS
WS16BF16	2"	G2" BSPP	Steel

WS-SERIES HIGH PRESSURE WING STYLE (VIEW-PORT COUPLER)



(Female Thread)

PART NO.	BODY SIZE	THREAD SIZE	BODY MATERIAL
6WSF6-VP	3/4"	3/4"-14 NPTF	Steel
6WSF6-SS-VP *	3/4"	3/4"-14 NPTF	316 SS
6WSBF6-VP	3/4"	G3/4" BSPP	Steel
8WSF8-VP	1"	1"-11 1/2 NPTF	Steel
8WSF8-SS-VP *	1"	1"-11 1/2 NPTF	316 SS
8WSBF8-VP	1"	G1" BSPP	Steel
10WSF10-VP	1 1/4"	1 1/4"-11 1/2 NPTF	Steel
10WSF10-SS-VP *	1 1/4"	1 1/4"-11 1/2 NPTF	316 SS
10WSBF10-VP	1 1/4"	G1 1/4" BSPP	Steel
12WSF12-VP	1 1/2"	1 1/2"-11 1/2 NPTF	Steel
12WSF12-SS-VP *	1 1/2"	1 1/2"-11 1/2 NPTF	316 SS
12WSBF12-VP	1 1/2"	G1 1/2" BSPP	Steel
16WSF16-VP	2"	2"-11 1/2 NPTF	Steel
16WSF16-SS-VP *	2"	2"-11 1/2 NPTF	316 SS
16WSBF16-VP	2"	G2" BSPP	Steel

Please note: The Connection View-Port Coupler has two View-Ports drilled 180° apart to provide a visual confirmation of complete connection.

* Standard deliveries, contact factory for details.

WS-Series Blowout Prevention Safety Coupling

- Fire tested and Lloyd's certified to 700°C (1300°F) in accordance with API 16D (Certificate #NAO 0601041/1)

This certificate applies to the 1" size only. During the certification for the 1" size, Dixon was advised by Lloyds during the process that the 1" would set the precedence for the rest of the series and sizes. Dixon confirm that all other sizes of WS-Series BOP Couplings (3/4", 1-1/4", 1-1/2", 2") are manufactured to the same quality and standard as the 1". Copies of this certification are available.

- Designed for hazardous area service where couplings are required to operate under fire conditions in an emergency
- Sleeve is cast using a unique process that provides better surface finishes, tighter tolerance control, and excellent repeatability
- Blowout Prevention Couplings are individually marked with the BOP series designation and manufacturing date code



PERFORMANCE SPECIFICATIONS	OPERATING bar (psi)	COUPLED BURST bar (psi)	FLOW RATE ΔP=2 bar	LOCKING MECHANISM
3/4" Steel	345 (5,000)	1,380 (20,000)	157 LPM (40 GPM)	Threaded
1" Steel	345 (5,000)	1,380 (20,000)	227 LPM (60 GPM)	Threaded
1 1/4" Steel	345 (5,000)	1,035 (15,000)	310 LPM (82 GPM)	Threaded
1 1/2" Steel	345 (5,000)	1,035 (15,000)	416 LPM (110 GPM)	Threaded
2" Steel	345 (5,000)	1,035 (15,000)	908 LPM (240 GPM)	Threaded

Please Note: To calculate the working pressure of 316SS parts, multiply the above Operating Pressures by 0.35



(Female Thread)

Wrench flats are pictured, non-flat fittings are standard

* Stainless Steel models have an extended lead time as they are built-on-demand. Contact factory for details.

WS-SERIES BLOWOUT PREVENTION SAFETY COUPLING (COUPLER)

PART NO.	BODY SIZE	THREAD SIZE	BODY MATERIAL
6WSF4-BOP	3/4"	1/2"-14 NPTF	Steel
6WSF6-BOP	3/4"	3/4"-14 NPTF	Steel
6WSF6-SS-BOP *	3/4"	3/4"-14 NPTF	316 SS
6WSBF6-BOP	3/4"	G3/4" BSPP	Steel
8WSF8-BOP	1"	1"-11 1/2 NPTF	Steel
8WSF8-SS-BOP *	1"	1"-11 1/2 NPTF	316 SS
8WSBF8-BOP	1"	G1" BSPP	Steel
10WSF10-BOP	1 1/4"	1 1/4"-11 1/2 NPTF	Steel
10WSF10-SS-BOP *	1 1/4"	1 1/4"-11 1/2 NPTF	316 SS
10WSBF10-BOP	1 1/4"	G1 1/4" BSPP	Steel
12WSF12-BOP	1 1/2"	1 1/2"-11 1/2 NPTF	Steel
12WSF12-SS-BOP *	1 1/2"	1 1/2"-11 1/2 NPTF	316 SS
12WSBF12-BOP	1 1/2"	G1-1/2" BSPP	Steel
16WSF16-BOP	2"	2"-11 1/2 NPTF	Steel
16WSF16-SS-BOP *	2"	2"-11 1/2 NPTF	316 SS
16WSBF16-BOP	2"	G2" BSPP	Steel



(Male Thread)

Wrench flats are pictured, non-flat fittings are standard

* Stainless Steel models have an extended lead time as they are built-on-demand. Contact factory for details.

WS-SERIES BLOWOUT PREVENTION SAFETY COUPLING (NIPPLE)

PART NO.	BODY SIZE	THREAD SIZE	BODY MATERIAL
WS6F4-BOP	3/4"	1/2"-14 NPTF	Steel
WS6F6-BOP	3/4"	3/4"-14 NPTF	Steel
WS6F6-SS-BOP *	3/4"	3/4"-14 NPTF	316 SS
WS6BF6-BOP	3/4"	G3/4" BSPP	Steel
WS8F8-BOP	1"	1"-11 1/2 NPTF	Steel
WS8F8-SS-BOP *	1"	1"-11 1/2 NPTF	316 SS
WS8BF8-BOP	1"	G1" BSPP	Steel
WS10F10-BOP	1 1/4"	1 1/4"-11 1/2 NPTF	Steel
WS10F10-SS-BOP *	1 1/4"	1 1/4"-11 1/2 NPTF	316 SS
WS10BF10-BOP	1 1/4"	G1 1/4" BSPP	Steel
WS12F12-BOP	1 1/2"	1 1/2"-11 1/2 NPTF	Steel
WS12F12-SS-BOP *	1 1/2"	1 1/2"-11 1/2 NPTF	316 SS
WS12BF12-BOP	1 1/2"	G1-1/2" BSPP	Steel
WS16F16-BOP	2"	2"-11 1/2 NPTF	Steel
WS16F16-SS-BOP *	2"	2"-11 1/2 NPTF	316 SS
WS16BF16-BOP	2"	G2" BSPP	Steel

PD-Series ISO15171-1 Diagnostic Interchange

- Couplings provide no-spill connection/disconnection for pressure diagnostic applications
- PD-Series couplers and nipples are fully compliant with the parameters outlined in ISO15171-1
- Couplers have an automatic push-to-connect sleeve for easy connection and disconnection
- Plated steel construction provides optimum corrosion resistance



PERFORMANCE SPECIFICATIONS	OPERATING bar (psi)	COUPLED BURST bar (psi)	FLOW RATE ΔP=5 bar	LOCKING MECHANISM
1/8" Steel	414 (6,000)	1,655 (24,000)	3 LPM (0.80 GPM)	10 Balls
'PD' SERIES INTERCHANGE	PARKER	AEROQUIP	TOMCO	FASTER
1/8" Steel	PD-Series	FD90	Series DK	Series DF



(Female Thread)

PD-SERIES ISO15171-1 DIAGNOSTIC INTERCHANGE (COUPLER)			
PART NO.	BODY SIZE	THREAD SIZE	BODY MATERIAL
1PDF1	1/8"	1/8"- 27 NPTF	Steel
1PDF2	1/8"	1/4"-18 NPTF	Steel



(Female Thread)

PD-SERIES ISO15171-1 DIAGNOSTIC INTERCHANGE (NIPPLE)			
PART NO.	BODY SIZE	THREAD SIZE	BODY MATERIAL
PD1F1	1/8"	1/8"- 27 NPTF	Steel
PD1F2	1/8"	1/4"-18 NPTF	Steel



(Male Thread)

PD-SERIES ISO15171-1 DIAGNOSTIC INTERCHANGE (COUPLER)			
PART NO.	BODY SIZE	THREAD SIZE	BODY MATERIAL
1PDM2	1/8"	1/8"- 27 NPTF	Steel



(Male Thread)

PD-SERIES ISO15171-1 DIAGNOSTIC INTERCHANGE (NIPPLE)			
PART NO.	BODY SIZE	THREAD SIZE	BODY MATERIAL
PD1M1	1/8"	1/8"-27 NPTF	Steel
PD1M2	1/8"	1/4"-18 NPTF	Steel
PD1OM2	1/8"	7/16"-20 ORB	Steel
PD1OM3	1/8"	9/16"-18 ORB	Steel

Quick Release Couplings

V Series: Snap-Tite H/IH Interchange

- V-Series couplers and nipples are fully interchangeable to the parameters outlined in MIL-C-5123
- Couplers have a high concentration of locking balls to reduce incidents of brinelling during operation
- Large diameter heavy duty knurled sleeves are designed to resist brinelling and maximise performance under impulse conditions
- Available in single shut-off, double shut-off, or straight through configurations with a wide selection of end connections



PERFORMANCE 'UNVALVED'	OPERATING bar (psi)	BURST bar (psi)	FLOW RATE $\Delta P=2$ bar	LOCKING MECHANISM
1/4" Steel	448 (6,500)	759 (11,000)	17 LPM (4.5 GPM)	6 Balls
3/8" Steel	310 (4,500)	759 (11,000)	24.6 LPM (6.5 GPM)	6 Balls
1/2" Steel	276 (4,000)	759 (11,000)	64 LPM (17 GPM)	9 Balls
3/4" Steel	241 (3,500)	621 (9,000)	132 LPM (35 GPM)	9 Balls
1" Steel	138 (2,000)	414 (6,000)	163 LPM (43 GPM)	12 Balls
1 1/4" Steel	121 (1,750)	345 (5,000)	265 LPM (70 GPM)	12 Balls
1 1/2" Steel	103 (1,500)	345 (5,000)	405 LPM (107 GPM)	12 Balls
2" Steel	103 (1,500)	276 (4,000)	738 LPM (195 GPM)	12 Balls
1/4" Brass	155 (2,250)	280 (4,000)	17 LPM (4.5 GPM)	6 Balls
3/8" Brass	155 (2,250)	280 (4,000)	24.6 LPM (6.5 GPM)	6 Balls
1/2" Brass	140 (2,000)	280 (4,000)	64 LPM (17 GPM)	9 Balls
3/4" Brass	140 (2,000)	245 (3,500)	132 LPM (35 GPM)	9 Balls
1" Brass	125 (2,000)	210 (3,000)	163 LPM (43 GPM)	12 Balls
1 1/4" Brass	25 (350)	70 (1,000)	265 LPM (70 GPM)	12 Balls
1 1/2" Brass	25 (350)	70 (1,000)	405 LPM (107 GPM)	12 Balls
2" Brass	25 (400)	55 (750)	738 LPM (195 GPM)	12 Balls
1/4 316 SS	345 (5,000)	690 (10,000)	17 LPM (4.5 GPM)	6 Balls
3/8" 316 SS	280 (4,000)	555 (8,000)	24.6 LPM (6.5 GPM)	6 Balls
1/2" 316 SS	260 (3,750)	555 (8,000)	64 LPM (17 GPM)	9 Balls
3/4" 316 SS	140 (2,000)	485 (7,000)	132 LPM (35 GPM)	9 Balls
1" 316 SS	140 (2,000)	280 (4,000)	163 LPM (43 GPM)	12 Balls
1 1/4" 316 SS	105 (1,500)	210 (3,000)	265 LPM (70 GPM)	12 Balls
1 1/2" 316 SS	105 (1,500)	210 (3,000)	405 LPM (107 GPM)	12 Balls
2" 316 SS	35 (500)	70 (1,000)	738 LPM (195 GPM)	12 Balls

Please note: Minimum burst pressure ratings were established under laboratory conditions using a Static Burst Unit (SBU). For high impulse applications and to meet Det Norske Veritas (DNV) compliance, the operating pressure must be divided by two (2) to ensure a 4:1 safety factor during system operation.

INTERCHANGE STANDARDS	US MILITARY	INDUSTRY STANDARDS	INTERNATIONAL STANDARDS	ANSI/NFPA
1/4"	MIL-C-51234	-	-	-
3/8"	MIL-C-51234	-	-	-
1/2"	MIL-C-51234	-	-	-
3/4"	MIL-C-51234	-	-	-
1"	MIL-C-51234	-	-	-
1 1/4"	MIL-C-51234	-	-	-
1 1/2"	MIL-C-51234	-	-	-
2"	MIL-C-51234	-	-	-

'V' SERIES INTERCHANGE	SNAP-TITE	FASTER	PCI
1/4"	Series 'H/IH'	TNV/TNL	TNV/TNL
3/8"	Series 'H/IH'	TNV/TNL	TNV/TNL
1/2"	Series 'H/IH'	TNV/TNL	TNV/TNL
3/4"	Series 'H/IH'	TNV/TNL	TNV/TNL
1"	Series 'H/IH'	TNV/TNL	TNV/TNL
1 1/4"	Series 'H/IH'	TNV/TNL	TNV/TNL
1 1/2"	Series 'H/IH'	TNV/TNL	TNV/TNL
2"	Series 'H/IH'	TNV/TNL	TNV/TNL

V-SERIES SNAP-TITE 'H' INTERCHANGE (VALVED COUPLER)



(Male Thread)

PART NO.	BODY SIZE	THREAD SIZE	BODY MATERIAL
2VM1	1/4"	1/8"-27 NPTF	Steel
2VM2	1/4"	1/4"-18 NPTF	Steel
2VM2-B	1/4"	1/4"-18 NPTF	Brass
2VM2-SS	1/4"	1/4"-18 NPTF	316 SS
2VJM2	1/4"	7/16"-20 JIC	Steel
3VM3	3/8"	3/8"-18 NPTF	Steel
3VM3-B	3/8"	3/8"-18 NPTF	Brass
3VM3-SS	3/8"	3/8"-18 NPTF	316 SS
3VJM3	3/8"	9/16"-18 JIC	Steel
4VM4	1/2"	1/2"-14 NPTF	Steel
4VM4-B	1/2"	1/2"-14 NPTF	Brass
4VM4-SS	1/2"	1/2"-14 NPTF	316 SS
4VJM4	1/2"	3/4"-16 JIC	Steel
6VM6	3/4"	3/4"-14 NPTF	Steel
6VM6-B	3/4"	3/4"-14 NPTF	Brass
6VM6-SS	3/4"	3/4"-14 NPTF	316 SS
6VJM6	3/4"	1 1/16"-12 JIC	Steel
8VM8	1"	1"-11 1/2 NPTF	Steel
8VM8-B	1"	1"-11 1/2 NPTF	Brass
8VM8-SS	1"	1"-11 1/2 NPTF	316 SS
8VJM8	1"	1 5/16"-12 JIC	Steel
10VM10	1 1/4"	1 1/4"-11 1/2 NPTF	Steel
10VM10-B	1 1/4"	1 1/4"-11 1/2 NPTF	Brass
10VM10-SS	1 1/4"	1 1/4"-11 1/2 NPTF	316 SS
10VJM10	1 1/4"	1 5/8"-12 JIC	Steel
12VM12	1 1/2"	1 1/2"-11 1/2 NPTF	Steel
12VM12-B	1 1/2"	1 1/2"-11 1/2 NPTF	Brass
12VM12-SS	1 1/2"	1 1/2"-11 1/2 NPTF	316 SS
12VJM12	1 1/2"	1- 7/8"-12 JIC	Steel
16VM16	2"	2"-11 1/2 NPTF	Steel
16VM16-B	2"	2"-11 1/2 NPTF	Brass
16VM16-SS	2"	2"-11 1/2 NPTF	316 SS

V-SERIES SNAP-TITE 'H' INTERCHANGE (VALVED NIPPLE)



(Male Thread)

PART NO.	BODY SIZE	THREAD SIZE	BODY MATERIAL
V2M1	1/4"	1/8"-27 NPTF	Steel
V2M2	1/4"	1/4"-18 NPTF	Steel
V2M2-B	1/4"	1/4"-18 NPTF	Brass
V2M2-SS	1/4"	1/4"-18 NPTF	316 SS
V2JM2	1/4"	7/16"-20 JIC	Steel
V3M3	3/8"	3/8"-18 NPTF	Steel
V3M3-B	3/8"	3/8"-18 NPTF	Brass
V3M3-SS	3/8"	3/8"-18 NPTF	316 SS
V3JM3	3/8"	9/16"-18 JIC	Steel
V4M4	1/2"	1/2"-14 NPTF	Steel
V4M4-B	1/2"	1/2"-14 NPTF	Brass
V4M4-SS	1/2"	1/2"-14 NPTF	316 SS
V4JM4	1/2"	3/4"-16 JIC	Steel
V6M6	3/4"	3/4"-14 NPTF	Steel
V6M6-B	3/4"	3/4"-14 NPTF	Brass
V6M6-SS	3/4"	3/4"-14 NPTF	316 SS
V6JM6	3/4"	1 1/16"-12 JIC	Steel
V8M8	1"	1"-11 1/2 NPTF	Steel
V8M8-B	1"	1"-11 1/2 NPTF	Brass
V8M8-SS	1"	1"-11 1/2 NPTF	316 SS
V8JM8	1"	1-5/16"-12 JIC	Steel
V10M10	1 1/4"	1 1/4"-11 1/2 NPTF	Steel
V10M10-B	1 1/4"	1 1/4"-11 1/2 NPTF	Brass
V10M10-SS	1 1/4"	1 1/4"-11 1/2 NPTF	316 SS
V10JM10	1 1/4"	1 5/8"-12 JIC	Steel
V12M12	1 1/2"	1 1/2"-11 1/2 NPTF	Steel
V12M12-B	1 1/2"	1 1/2"-11 1/2 NPTF	Brass
V12M12-SS	1 1/2"	1 1/2"-11 1/2 NPTF	316 SS
V12JM12	1 1/2"	1 7/8"-12 JIC	Steel
V16M16	2"	2"-11 1/2 NPTF	Steel
V16M16-B	2"	2"-11 1/2 NPTF	Brass
V16M16-SS	2"	2"-11 1/2 NPTF	316 SS

Quick Release Couplings

V-SERIES SNAP-TITE 'H' INTERCHANGE (VALVED COUPLER)



(Female Thread)

PART NO.	BODY SIZE	THREAD SIZE	BODY MATERIAL
2VF1	1/4"	1/8"-27 NPTF	Steel
2VF2	1/4"	1/4"-18 NPTF	Steel
2VF2-B	1/4"	1/4"-18 NPTF	Brass
2VF2-SS	1/4"	1/4"-18 NPTF	316 SS
2VOF2	1/4"	7/16"-20 ORB	Steel
2VBF2	1/4"	G1/4" BSPP	Steel
2VBF2-B	1/4"	G1/4" BSPP	Brass
2VBF2-SS	1/4"	G1/4" BSPP	316 SS
3VF3	3/8"	3/8"-18 NPTF	Steel
3VF3-B	3/8"	3/8"-18 NPTF	Brass
3VF3-SS	3/8"	3/8"-18 NPTF	316 SS
3VOF3	3/8"	9/16"-18 ORB	Steel
3VBF3	3/8"	G3/8" BSPP	Steel
3VBF3-B	3/8"	G3/8" BSPP	Brass
3VBF3-SS	3/8"	G3/8" BSPP	316 SS
3VF4	3/8"	1/2"-14 NPTF	Steel
4VF4	1/2"	1/2"-14 NPTF	Steel
4VF4-B	1/2"	1/2"-14 NPTF	Brass
4VF4-SS	1/2"	1/2"-14 NPTF	316 SS
4VOF4	1/2"	3/4"-16 ORB	Steel
4VBF4	1/2"	G1/2" BSPP	Steel
4VBF4-B	1/2"	G1/2" BSPP	Brass
4VBF4-SS	1/2"	G1/2" BSPP	316 SS
4VF6	1/2"	3/4"-14 NPTF	Steel
6VF6	3/4"	3/4"-14 NPTF	Steel
6VF6-B	3/4"	3/4"-14 NPTF	Brass
6VF6-SS	3/4"	3/4"-14 NPTF	316 SS
6VOF6	3/4"	1 1/16"-12 ORB	Steel
6VBF6	3/4"	G3/4" BSPP	Steel
6VBF6-B	3/4"	G3/4" BSPP	Brass
6VBF6-SS	3/4"	G3/4" BSPP	316 SS
8VF8	1"	1"-11 1/2 NPTF	Steel
8VF8-B	1"	1"-11 1/2 NPTF	Brass
8VF8-SS	1"	1"-11 1/2 NPTF	316 SS
8VOF8	1"	1 5/16"-12 ORB	Steel
8VBF8	1"	G1" BSPP	Steel
8VBF8-B	1"	G1" BSPP	Brass
8VBF8-SS	1"	G1" BSPP	316 SS
10VF10	1 1/4"	1 1/4"-11 1/2 NPTF	Steel
10VF10-B	1 1/4"	1 1/4"-11 1/2 NPTF	Brass
10VF10-SS	1 1/4"	1 1/4"-11 1/2 NPTF	316 SS
10VOF10	1 1/4"	1 5/8"-12 ORB	Steel
10VBF10	1 1/4"	G1-1/4" BSPP	Steel
10VBF10-B	1 1/4"	G1-1/4" BSPP	Brass
10VBF10-SS	1 1/4"	G1-1/4" BSPP	316SS
12VF12	1 1/2"	1 1/2"-11 1/2 NPTF	Steel
12VF12-B	1 1/2"	1 1/2"-11 1/2 NPTF	Brass
12VF12-SS	1 1/2"	1 1/2"-11 1/2 NPTF	316 SS
12VOF12	1 1/2"	1 7/8"-12 ORB	Steel
12VBF12	1 1/2"	G1 1/2" BSPP	Steel
12VBF12-B	1 1/2"	G1 1/2" BSPP	Brass
12VBF12-SS	1 1/2"	G1 1/2" BSPP	316 SS
16VF16	2"	2"-11 1/2 NPTF	Steel
16VF16-B	2"	2"-11 1/2 NPTF	Brass
16VF16-SS	2"	2"-11 1/2 NPTF	316 SS
16VBF16	2"	G2" BSPP	Steel
16VBF16-B	2"	G2" BSPP	Brass
16VBF16-SS	2"	G2" BSPP	316 SS

V-SERIES SNAP-TITE 'H' INTERCHANGE (COUPLER RIGID DUST PLUG)



PART NO.	BODY SIZE	THREAD SIZE	BODY MATERIAL
2VDP-A	1/4"	Steel chain	Aluminium
3VDP-A	3/8"	Steel chain	Aluminium
4VDP-A	1/2"	Steel chain	Aluminium
6VDP-A	3/4"	Steel chain	Aluminium
8VDP-A	1"	Steel chain	Aluminium
10VDP-A	1 1/4"	Steel chain	Aluminium
12VDP-A	1 1/2"	Steel chain	Aluminium
16VDP-A	2"	Steel chain	Aluminium

V-SERIES SNAP-TITE 'H' INTERCHANGE (VALVED NIPPLE)



(Female Thread)

PART NO.	BODY SIZE	THREAD SIZE	BODY MATERIAL
V2F1	1/4"	1/8"-27 NPTF	Steel
V2F2	1/4"	1/4"-18 NPTF	Steel
V2F2-B	1/4"	1/4"-18 NPTF	Brass
V2F2-SS	1/4"	1/4"-18 NPTF	316 SS
V2OF2	1/4"	7/16"-20 ORB	Steel
V2BF2	1/4"	G1/4" BSPP	Steel
V2BF2-B	1/4"	G1/4" BSPP	Brass
V2BF2-SS	1/4"	G1/4" BSPP	316 SS
V3F3	3/8"	3/8"-18 NPTF	Steel
V3F3-B	3/8"	3/8"-18 NPTF	Brass
V3F3-SS	3/8"	3/8"-18 NPTF	316 SS
V3OF3	3/8"	9/16"-18 ORB	Steel
V3BF3	3/8"	G3/8" BSPP	Steel
V3BF3-B	3/8"	G3/8" BSPP	Brass
V3BF3-SS	3/8"	G3/8" BSPP	316 SS
V3F4	3/8"	1/2"-14 NPTF	Steel
V4F4	1/2"	1/2"-14 NPTF	Steel
V4F4-B	1/2"	1/2"-14 NPTF	Brass
V4F4-SS	1/2"	1/2"-14 NPTF	316 SS
V4OF4	1/2"	3/4"-16 ORB	Steel
V4BF4	1/2"	G1/2" BSPP	Steel
V4BF4-B	1/2"	G1/2" BSPP	Brass
V4BF4-SS	1/2"	G1/2" BSPP	316 SS
V4F6	1/2"	3/4"-14 NPTF	Steel
V6F6	3/4"	3/4"-14 NPTF	Steel
V6F6-B	3/4"	3/4"-14 NPTF	Brass
V6F6-SS	3/4"	3/4"-14 NPTF	316 SS
V6OF6	3/4"	1 1/16"-12 ORB	Steel
V6BF6	3/4"	G3/4" BSPP	Steel
V6BF6-B	3/4"	G3/4" BSPP	Brass
V6BF6-SS	3/4"	G3/4" BSPP	316 SS
V8F8	1"	1"-11 1/2 NPTF	Steel
V8F8-B	1"	1"-11 1/2 NPTF	Brass
V8F8-SS	1"	1"-11 1/2 NPTF	316 SS
V8OF8	1"	1 5/16"-12 ORB	Steel
V8BF8	1"	G1" BSPP	Steel
V8BF8-B	1"	G1" BSPP	Brass
V8BF8-SS	1"	G1" BSPP	316 SS
V10F10	1 1/4"	1 1/4"-11 1/2 NPTF	Steel
V10F10-B	1 1/4"	1 1/4"-11 1/2 NPTF	Brass
V10F10-SS	1 1/4"	1 1/4"-11 1/2 NPTF	316 SS
V10OF10	1 1/4"	1 5/8"-12 ORB	Steel
V10BF10	1 1/4"	G1-1/4" BSPP	Steel
V10BF10-B	1 1/4"	G1-1/4" BSPP	Brass
V10BF10-SS	1 1/4"	G1-1/4" BSPP	316SS
V12F12	1 1/2"	1 1/2"-11 1/2 NPTF	Steel
V12F12-B	1 1/2"	1 1/2"-11 1/2 NPTF	Brass
V12F12-SS	1 1/2"	1 1/2"-11 1/2 NPTF	316 SS
V12OF12	1 1/2"	1 7/8"-12 ORB	Steel
V12BF12	1 1/2"	G1 1/2" BSPP	Steel
V12BF12-B	1 1/2"	G1 1/2" BSPP	Brass
V12BF12-SS	1 1/2"	G1 1/2" BSPP	316 SS
V16F16	2"	2"-11 1/2 NPTF	Steel
V16F16-B	2"	2"-11 1/2 NPTF	Brass
V16F16-SS	2"	2"-11 1/2 NPTF	316 SS
V16BF16	2"	G2" BSPP	Steel
V16BF16-B	2"	G2" BSPP	Brass
V16BF16-SS	2"	G2" BSPP	316 SS

V-SERIES SNAP-TITE 'H' INTERCHANGE (NIPPLE RIGID DUST CAP)



PART NO.	BODY SIZE	THREAD SIZE	BODY MATERIAL
V2DC-A	1/4"	Steel chain	Aluminium
V3DC-A	3/8"	Steel chain	Aluminium
V4DC-A	1/2"	Steel chain	Aluminium
V6DC-A	3/4"	Steel chain	Aluminium
V8DC-A	1"	Steel chain	Aluminium
V10DC-A	1 1/4"	Steel chain	Aluminium
V12DC-A	1 1/2"	Steel chain	Aluminium
V16DC-A	2"	Steel chain	Aluminium

Quick Release Couplings

V-SERIES SNAP-TITE 'H' INTERCHANGE (UNVALVED COUPLER)

PART NO.	BODY SIZE	THREAD SIZE	BODY MATERIAL
2VF2-E	1/4"	1/4"-18 NPTF	Steel
2VF2-B-E	1/4"	1/4"-18 NPTF	Brass
2VF2-SS-E	1/4"	1/4"-18 NPTF	316 SS
2VBF2-E	1/4"	G1/4" BSPP	Steel
2VBF2-B-E	1/4"	G1/4" BSPP	Brass
2VBF2-SS-E	1/4"	G1/4" BSPP	316 SS
3VF3-E	3/8"	3/8"-18 NPTF	Steel
3VF3-B-E	3/8"	3/8"-18 NPTF	Brass
3VF3-SS-E	3/8"	3/8"-18 NPTF	316 SS
3VBF3-E	3/8"	G3/8" BSPP	Steel
3VBF3-B-E	3/8"	G3/8" BSPP	Brass
3VBF3-SS-E	3/8"	G3/8" BSPP	316 SS
4VF4-E	1/2"	1/2"-14 NPTF	Steel
4VF4-B-E	1/2"	1/2"-14 NPTF	Brass
4VF4-SS-E	1/2"	1/2"-14 NPTF	316 SS
4VBF4-E	1/2"	G1/2" BSPP	Steel
4VBF4-B-E	1/2"	G1/2" BSPP	Brass
4VBF4-SS-E	1/2"	G1/2" BSPP	316 SS
6VF6-E	3/4"	3/4"-14 NPTF	Steel
6VF6-B-E	3/4"	3/4"-14 NPTF	Brass
6VF6-SS-E	3/4"	3/4"-14 NPTF	316 SS
6VBF6-E	3/4"	G3/4" BSPP	Steel
6VBF6-B-E	3/4"	G3/4" BSPP	Brass
6VBF6-SS-E	3/4"	G3/4" BSPP	316 SS
8VF8-E	1"	1"-11 1/2 NPTF	Steel
8VF8-B-E	1"	1"-11 1/2 NPTF	Brass
8VF8-SS-E	1"	1"-11 1/2 NPTF	316 SS
8VBF8-E	1"	G1" BSPP	Steel
8VBF8-B-E	1"	G1" BSPP	Brass
8VBF8-SS-E	1"	G1" BSPP	316SS
10VF10-E	1 1/4"	1 1/4"-11 1/2 NPTF	Steel
10VF10-B-E	1 1/4"	1 1/4"-11 1/2 NPTF	Brass
10VF10-SS-E	1 1/4"	1 1/4"-11 1/2 NPTF	316 SS
10VBF10-E	1 1/4"	G1 1/4" BSPP	Steel
10VBF10-B-E	1 1/4"	G1 1/4" BSPP	Brass
10VBF10-SS-E	1 1/4"	G1 1/4" BSPP	316 SS
12VF12-E	1 1/2"	1 1/2"-11 1/2 NPTF	Steel
12VF12-B-E	1 1/2"	1 1/2"-11 1/2 NPTF	Brass
12VF12-SS-E	1 1/2"	1 1/2"-11 1/2 NPTF	316 SS
12VBF12-E	1 1/2"	G1 1/2" BSPP	Steel
12VBF12-B-E	1 1/2"	G1 1/2" BSPP	Brass
12VBF12-SS-E	1 1/2"	G1 1/2" BSPP	316 SS
16VF16-E	2"	2"-11 1/2 NPTF	Steel
16VF16-B-E	2"	2"-11 1/2 NPTF	Brass
16VF16-SS-E	2"	2"-11 1/2 NPTF	316 SS
16VBF16-E	2"	G2" BSPP	Steel
16VBF16-B-E	2"	G2" BSPP	Brass
16VBF16-SS-E	2"	G2" BSPP	316 SS



(Female Thread)

V-SERIES SNAP-TITE 'H' INTERCHANGE (UNVALVED COUPLER)

PART NO.	BODY SIZE	THREAD SIZE	BODY MATERIAL
2VM2-E	1/4"	1/4"-18 NPTF	Steel
2VM2-B-E	1/4"	1/4"-18 NPTF	Brass
2VM2-SS-E	1/4"	1/4"-18 NPTF	316 SS
3VM3-E	3/8"	3/8"-18 NPTF	Steel
3VM3-B-E	3/8"	3/8"-18 NPTF	Brass
3VM3-SS-E	3/8"	3/8"-18 NPTF	316 SS
4VM4-E	1/2"	1/2"-14 NPTF	Steel
4VM4-B-E	1/2"	1/2"-14 NPTF	Brass
4VM4-SS-E	1/2"	1/2"-14 NPTF	316 SS
6VM6-E	3/4"	3/4"-14 NPTF	Steel
6VM6-B-E	3/4"	3/4"-14 NPTF	Brass
6VM6-SS-E	3/4"	3/4"-14 NPTF	316 SS
8VM8-E	1"	1"-11 1/2 NPTF	Steel
8VM8-B-E	1"	1"-11 1/2 NPTF	Brass
8VM8-SS-E	1"	1"-11 1/2 NPTF	316 SS
10VM10-E	1 1/4"	1 1/4"-11 1/2 NPTF	Steel
10VM10-SS-E	1 1/4"	1 1/4"-11 1/2 NPTF	316 SS
12VM12-E	1 1/2"	1 1/2"-11 1/2 NPTF	Steel
12VM12-SS-E	1 1/2"	1 1/2"-11 1/2 NPTF	316 SS
16VM16-E	2"	2"-11 1/2 NPTF	Steel
16VM16-SS-E	2"	2"-11 1/2 NPTF	316 SS



(Male Thread)

V-SERIES SNAP-TITE 'H' INTERCHANGE (NIPPLE RIGID DUST CAP)

PART NO.	BODY SIZE	THREAD SIZE	BODY MATERIAL
V2F2-E	1/4"	1/4"-18 NPTF	Steel
V2F2-B-E	1/4"	1/4"-18 NPTF	Brass
V2F2-SS-E	1/4"	1/4"-18 NPTF	316 SS
V2BF2-E	1/4"	G1/4" BSPP	Steel
V2BF2-B-E	1/4"	G1/4" BSPP	Brass
V2BF2-SS-E	1/4"	G1/4" BSPP	316 SS
V3F3-E	3/8"	3/8"-18 NPTF	Steel
V3F3-B-E	3/8"	3/8"-18 NPTF	Brass
V3F3-SS-E	3/8"	3/8"-18 NPTF	316 SS
V3BF3-E	3/8"	G3/8" BSPP	Steel
V3BF3-B-E	3/8"	G3/8" BSPP	Brass
V3BF3-SS-E	3/8"	G3/8" BSPP	316 SS
V4F4-E	1/2"	1/2"-14 NPTF	Steel
V4F4-B-E	1/2"	1/2"-14 NPTF	Brass
V4F4-SS-E	1/2"	1/2"-14 NPTF	316 SS
V4BF4-E	1/2"	G1/2" BSPP	Steel
V4BF4-B-E	1/2"	G1/2" BSPP	Brass
V4BF4-SS-E	1/2"	G1/2" BSPP	316 SS
V6F6-E	3/4"	3/4"-14 NPTF	Steel
V6F6-B-E	3/4"	3/4"-14 NPTF	Brass
V6F6-SS-E	3/4"	3/4"-14 NPTF	316 SS
V6BF6-E	3/4"	1G3/4" BSPP	Steel
V6BF6-B-E	3/4"	G3/4" BSPP	Brass
V6BF6-SS-E	3/4"	G3/4" BSPP	316 SS
V8F8-E	1"	1"-11 1/2 NPTF	Steel
V8F8-B-E	1"	1"-11 1/2 NPTF	Brass
V8F8-SS-E	1"	1"-11 1/2 NPTF	316 SS
V8BF8-E	1"	G1" BSPP	Steel
V8BF8-B-E	1"	G1" BSPP	Brass
V8BF8-SS-E	1"	G1" BSPP	316 SS
V10F10-E	1 1/4"	1 1/4"-11 1/2 NPTF	Steel
V10F10-B-E	1 1/4"	1 1/4"-11 1/2 NPTF	Brass
V10F10-SS-E	1 1/4"	1 1/4"-11 1/2 NPTF	316 SS
V10BF10-E	1 1/4"	G1 1/4" BSPP	Steel
V10BF10-B-E	1 1/4"	G1 1/4" BSPP	Brass
V10BF10-SS-E	1 1/4"	G1 1/4" BSPP	316 SS
V12F12-E	1 1/2"	1 1/2"-11 1/2 NPTF	Steel
V12F12-B-E	1 1/2"	1 1/2"-11 1/2 NPTF	Brass
V12F12-SS-E	1 1/2"	1 1/2"-11 1/2 NPTF	316 SS
V12BF12-E	1 1/2"	G1 1/2" BSPP	Steel
V12BF12-B-E	1 1/2"	G1 1/2" BSPP	Brass
V12BF12-SS-E	1 1/2"	G1 1/2" BSPP	316 SS
V16F16-E	2"	2"-11 1/2 NPTF	Steel
V16F16-B-E	2"	2"-11 1/2 NPTF	Brass
V16F16-SS-E	2"	2"-11 1/2 NPTF	316 SS
V16BF16-E	2"	G2" BSPP	Steel
V16BF16-B-E	2"	G2" BSPP	Brass
V16BF16-SS-E	2"	G2" BSPP	316 SS



(Female Thread)

V-SERIES SNAP-TITE 'H' INTERCHANGE (UNVALVED NIPPLE)

PART NO.	BODY SIZE	THREAD SIZE	BODY MATERIAL
V2M2-E	1/4"	1/4"-18 NPTF	Steel
V2M2-B-E	1/4"	1/4"-18 NPTF	Brass
V2M2-SS-E	1/4"	1/4"-18 NPTF	316 SS
V3M3-E	3/8"	3/8"-18 NPTF	Steel
V3M3-B-E	3/8"	3/8"-18 NPTF	Brass
V3M3-SS-E	3/8"	3/8"-18 NPTF	316 SS
V4M4-E	1/2"	1/2"-14 NPTF	Steel
V4M4-B-E	1/2"	1/2"-14 NPTF	Brass
V4M4-SS-E	1/2"	1/2"-14 NPTF	316 SS
V6M6-E	3/4"	3/4"-14 NPTF	Steel
V6M6-B-E	3/4"	3/4"-14 NPTF	Brass
V6M6-SS-E	3/4"	3/4"-14 NPTF	316 SS
V8M8-E	1"	1"-11 1/2 NPTF	Steel
V8M8-B-E	1"	1"-11 1/2 NPTF	Brass
V8M8-SS-E	1"	1"-11 1/2 NPTF	316 SS
V10M10-E	1 1/4"	1 1/4"-11 1/2 NPTF	Steel
V10M10-SS-E	1 1/4"	1 1/4"-11 1/2 NPTF	316 SS
V12M12-E	1 1/2"	1 1/2"-11 1/2 NPTF	Steel
V12M12-SS-E	1 1/2"	1 1/2"-11 1/2 NPTF	316 SS
V16M16-E	2"	2"-11 1/2 NPTF	Steel
V16M16-SS-E	2"	2"-11 1/2 NPTF	316 SS



(Male Thread)

Quick Release Couplings

T-Series High Pressure Screw-Together

- Threaded sleeve allows connection and disconnection while coupler and/or nipple are under pressure
- Urethane seal resists extrusion under high pressure during connection and disconnection



PERFORMANCE SPECIFICATIONS	OPERATING bar (psi)	MIN. BURST bar (psi)	FLOW RATE $\Delta P=3$ bar	LOCKING MECHANISM
1/4"	690 (10,000)	2,069 (30,000)	11 LPM (3 GPM)	Threaded
3/8"	690 (10,000)	2,069 (30,000)	23 LPM (6 GPM)	Threaded

Please Note: Divide Minimum Burst Pressure by four (4) for dynamic applications.

'T' SERIES INTERCHANGE	PARKER	STUCCHI	ENERPAC	HOLMBURY	FASTER
1/4"	Series 3000	IVHP	-	HPA Series	PVVM Series
3/8"	Series 3000	IVHP	C-604	HPA Series	PVVM Series



(Male Thread)

T-SERIES ENERPAC INTERCHANGE (COUPLER)

PART NO.	BODY SIZE	THREAD SIZE	BODY MATERIAL
2TM2	1/4"	1/4"-18 NPTF	Steel
2TBM2	1/4"	R1/4" BSPT	Steel
3TM3	3/8"	3/8"-18 NPTF	Steel
3TM3-SS	3/8"	3/8"-18 NPTF	316 SS
3TBM3	3/8"	R3/8" BSPT	Steel



(Female Thread)

T-SERIES ENERPAC INTERCHANGE (COUPLER)

PART NO.	BODY SIZE	THREAD SIZE	BODY MATERIAL
3TF3	3/8"	3/8"-18 NPTF	Steel



(Female Thread)

T-SERIES ENERPAC INTERCHANGE (NIPPLE)

PART NO.	BODY SIZE	THREAD SIZE	BODY MATERIAL
T2F2	1/4"	1/4"-18 NPTF	Steel
T2BF2	1/4"	G1/4" BSPP	Steel
T3F3	3/8"	3/8"-18 NPTF	Steel
T3F3-SS	3/8"	3/8"-18 NPTF	316 SS
T3BF3	3/8"	G3/8" BSPP	Steel



T-SERIES ENERPAC INTERCHANGE (COUPLER DUST PLUG)

PART NO.	BODY SIZE	CAP LANYARD	BODY MATERIAL
2TDP	1/4"	Elastomer	Steel
3TDP	3/8"	Elastomer	Steel



T-SERIES ENERPAC INTERCHANGE (NIPPLE DUST CAP)

PART NO.	BODY SIZE	CAP LANYARD	BODY MATERIAL
T2DC	1/4"	Chain	Steel
T3DC	3/8"	Chain	Steel

CVV-Series European Screw-Together Interchange

- Threaded sleeves enable easy connection and disconnection while system is under pressure
- O-ring “Connected” marker is highly visible during connection and helps to keep contaminants out of the threads while connected
- Unique thread profile ensures smooth connection and industry-wide interchangeability
- Highly versatile design is ideally suited for hydraulic systems experiencing pressure spikes or impulses
- Corrosion resistant high strength components maximise service life in a variety of applications



PERFORMANCE SPECIFICATIONS	OPERATING bar (psi)	COUPLED BURST bar (psi)	FLOW RATE $\Delta P=1$ bar	LOCKING MECHANISM
1/2" Steel	400 (5,800)	1,260 (18,270)	189 LPM (13 GPM)	Threaded
3/4" Steel	400 (5,800)	1,200 (17,400)	102 LPM (27 GPM)	Threaded
1" Steel	330 (4,785)	1,000 (14,500)	159 LPM (42 GPM)	Threaded
1 1/4" Steel	300 (4,350)	1,000 (14,500)	305 LPM (81 GPM)	Threaded
1 1/2" Steel	365 (5,295)	1,100 (15,950)	450 LPM (119 GPM)	Threaded

'CVV' SERIES INTERCHANGE	FASTER	DNP	ARGUS	VOSWINKEL
1/2"	CVV-Series	PVV3	Kupplengen	Type HS
3/4"	CVV-Series	PVV3	Kupplengen	Type HS
1"	CVV-Series	PVV3	Kupplengen	Type HS
1 1/4"	CVV-Series	PVV3	Kupplengen	Type HS
1 1/2"	CVV-Series	PVV3	Kupplengen	Type HS

CVV-SERIES EUROPEAN SCREW-TOGETHER INTERCHANGE (COUPLER)



(Female Thread)

PART NO.	BODY SIZE	THREAD SIZE	BODY MATERIAL
4CVVF4	1/2"	1/2"-14 NPTF	Steel
4CVVBF4	1/2"	G1/2"	Steel
6CVVF6	3/4"	3/4"-14 NPTF	Steel
6CVVBF6	3/4"	G3/4"	Steel
8CVVF8	1"	1"-11 1/2 NPTF	Steel
8CVVBF8	1"	G1"	Steel
10CVVF10	1 1/4"	1 1/4"-11 1/2 NPTF	Steel
10CVVBF10	1 1/4"	G1 1/4"	Steel

CVV-SERIES EUROPEAN SCREW-TOGETHER INTERCHANGE (NIPPLE)



(Female Thread)

PART NO.	BODY SIZE	THREAD SIZE	BODY MATERIAL
CVV4F4	1/2"	1/2"-14 NPTF	Steel
CVV4BF4	1/2"	G1/2"	Steel
CVV6F6	3/4"	3/4"-14 NPTF	Steel
CVV6BF6	3/4"	G3/4"	Steel
CVV8F8	1"	1"-11 1/2 NPTF	Steel
CVV8BF8	1"	G1"	Steel
CVV10F10	1 1/4"	1 1/4"-11 1/2 NPTF	Steel
CVV10BF10	1 1/4"	G1 1/4"	Steel

E-Series Straight-Through Interchange

- Smooth bore full-flow design ensures maximum flow with minimal pressure drop
- Straight-through interchange nipples are available in Brass, Steel, and 303 stainless Steel
- 1 1/4" to 2" sleeves are plated Steel to minimise incidents of brinelling during impulse service
- Ideally suited for pressure wash equipment, steam cleaning machines, and mould coolant lines
- Corrosion resistant components maximise service life in a variety of applications



PERFORMANCE SPECIFICATIONS	OPERATING bar (psi)	COUPLED BURST bar (psi)	FLOW RATE ΔP=1 bar	LOCKING MECHANISM
1/8" Steel	234 (3,400)	938 (13,600)	15 LPM (4 GPM)	8 Balls
1/4" Steel	379 (5,500)	1,344 (19,500)	30 LPM (8 GPM)	8 Balls
3/8" Steel	290 (4,200)	1,296 (18,800)	83 LPM (22 GPM)	8 Balls
1/2" Steel	241 (3,500)	1,097 (15,900)	125 LPM (33 GPM)	8 Balls
3/4" Steel	186 (2,700)	952 (13,800)	265 LPM (70 GPM)	8 Balls
1" Steel	138 (2,000)	724 (10,500)	303 LPM (80 GPM)	8 Balls
1 1/4" Steel	186 (2,700)	979 (14,200)	473 LPM (125 GPM)	8 Balls
1 1/2" Steel	152 (2,200)	1,000 (14,500)	568 LPM (150 GPM)	8 Balls
2" Steel	152 (2,200)	883 (12,800)	696 LPM (184 GPM)	8 Balls
1/8" Brass	193 (2,800)	793 (11,500)	15 LPM (4 GPM)	8 Balls
1/4" Brass	359 (5,200)	1,137 (16,500)	30 LPM (8 GPM)	8 Balls
3/8" Brass	193 (2,800)	1,097 (15,900)	83 LPM (22 GPM)	8 Balls
1/2" Brass	152 (2,200)	986 (14,300)	125 LPM (33 GPM)	8 Balls
3/4" Brass	117 (1,700)	855 (12,400)	265 LPM (70 GPM)	8 Balls
1" Brass	117 (1,700)	655 (9,500)	303 LPM (80 GPM)	8 Balls
1 1/4" Brass	117 (1,700)	724 (10,500)	473 LPM (125 GPM)	8 Balls
1 1/2" Brass	97 (1,400)	593 (8,600)	568 LPM (150 GPM)	8 Balls
2" Brass	97 (1,400)	593 (8,600)	696 LPM (184 GPM)	8 Balls
1/8" 303 SS	234 (3,400)	938 (13,600)	15 LPM (4 GPM)	8 Balls
1/4" 303 SS	379 (5,500)	1,344 (19,500)	30 LPM (8 GPM)	8 Balls
3/8" 303 SS	290 (4,200)	1,296 (18,800)	83 LPM (22 GPM)	8 Balls
1/2" 303 SS	241 (3,500)	1,097 (15,900)	125 LPM (33 GPM)	8 Balls
3/4" 303 SS	186 (2,700)	952 (13,800)	265 LPM (70 GPM)	8 Balls
1" 303 SS	138 (2,000)	724 (10,500)	303 LPM (80 GPM)	8 Balls
1 1/4" 303 SS	186 (2,700)	979 (14,200)	473 LPM (125 GPM)	8 Balls
1 1/2" 303 SS	152 (2,200)	1,000 (14,500)	568 LPM (150 GPM)	8 Balls
2" 303 SS	152 (2,200)	883 (12,800)	696 LPM (184 GPM)	8 Balls

* Steel performance specifications are as a result of using a steel plug with a Brass coupler.

** Brass performance specifications are as a result of using a Brass plug with a Brass coupler.

*** 303SS working pressure is as a result of using a 303SS plug with a 303SS coupler.

Please Note: Operating pressures for the E-Series couplings utilising hose barb end connections may be dramatically reduced to that of the hose rating and/or hose and end connection combination. Consult hose manufacturer's catalogue for hose end connection ratings. If in doubt, test under controlled conditions for suitability to application. Dixon Quick Coupling cannot assume liability for misapplication of products resulting in equipment down-time, lost production, property damage and/or personal injury including death.

'E' SERIES INTERCHANGE	PARKER	FOSTER	TOMCO	HANSEN
1/8"	ST-Series	FST-Series	Series ST	Series ST
1/4"	ST-Series	FST-Series	Series ST	Series ST
3/8"	ST-Series	FST-Series	Series ST	Series ST
1/2"	ST-Series	FST-Series	Series ST	Series ST
3/4"	ST-Series	FST-Series	Series ST	Series ST
1"	ST-Series	FST-Series	Series ST	Series ST
1 1/4"	ST-Series	FST-Series	Series ST	Series ST
1 1/2"	ST-Series	FST-Series	Series ST	Series ST
2"	---	---	---	Series ST

E-SERIES STRAIGHT-THROUGH INTERCHANGE (COUPLER)



(Female Thread)

PART NO.	BODY SIZE	THREAD SIZE	BODY MATERIAL
1EF1-B	1/8"	1/8"-27 NPTF	Brass
1EF1-S	1/8"	1/8"-27 NPTF	303 SS
2EF2-B	1/4"	1/4"-18 NPTF	Brass
2EBF2-B	1/4"	G1/4"	Brass
2EF2-S	1/4"	1/4"-18 NPTF	303 SS
3EF3-B	3/8"	3/8"-18 NPTF	Brass
3EBF3-B	3/8"	G3/8"	Brass
3EF3-S	3/8"	3/8"-18 NPTF	303 SS
4EF4-B	1/2"	1/2"-14 NPTF	Brass
4EBF4-B	1/2"	G1/2"	Brass
4EF4-S	1/2"	1/2"-14 NPTF	303 SS
6EF6-B	3/4"	3/4"-14 NPTF	Brass
6EBF6-B	3/4"	G3/4"	Brass
6EF6-S	3/4"	3/4"-14 NPTF	303 SS
8EF8-B	1"	1"-11 1/2 NPTF	Brass
8EBF8-B	1"	G1"	Brass
8EF8-S	1"	1"-11 1/2 NPTF	303 SS
10EF10-B	1 1/4"	1 1/4"-11 1/2 NPTF	Brass
10EF10-S	1 1/4"	1 1/4"-11 1/2 NPTF	303 SS
12EF12-B	1 1/2"	1 1/2"-11 1/2 NPTF	Brass
12EF12-S	1 1/2"	1 1/2"-11 1/2 NPTF	303 SS
16EF16-B	2"	2"-11 1/2 NPTF	Brass
16EF16-S	2"	2"-11 1/2 NPTF	303 SS

E-SERIES STRAIGHT-THROUGH INTERCHANGE (NIPPLE)



(Female Thread)

PART NO.	BODY SIZE	THREAD SIZE	BODY MATERIAL
E1F1	1/8"	1/8"-27 NPTF	Steel
E1F1-B	1/8"	1/8"-27 NPTF	Brass
E1F1-S	1/8"	1/8"-27 NPTF	303 SS
E2F2	1/4"	1/4"-18 NPTF	Steel
E2F2-B	1/4"	1/4"-18 NPTF	Brass
E2BF2-B	1/4"	G1/4"	Brass
E2F2-S	1/4"	1/4"-18 NPTF	303 SS
E3F3	3/8"	3/8"-18 NPTF	Steel
E3F3-B	3/8"	3/8"-18 NPTF	Brass
E3BF3-B	3/8"	G3/8"	Brass
E3F3-S	3/8"	3/8"-18 NPTF	303 SS
E4F4	1/2"	1/2"-14 NPTF	Steel
E4F4-B	1/2"	1/2"-14 NPTF	Brass
E4BF4-B	1/2"	G1/2"	Brass
E4F4-S	1/2"	1/2"-14 NPTF	303 SS
E6F6	3/4"	3/4"-14 NPTF	Steel
E6F6-B	3/4"	3/4"-14 NPTF	Brass
E6BF6-B	3/4"	G3/4"	Brass
E6F6-S	3/4"	3/4"-14 NPTF	303 SS
E8F8	1"	1"-11 1/2 NPTF	Steel
E8F8-B	1"	1"-11 1/2 NPTF	Brass
E8BF8-B	1"	G1"	Brass
E8F8-S	1"	1"-11 1/2 NPTF	303 SS
E10F10	1 1/4"	1 1/4"-11 1/2 NPTF	Steel
E10F10-B	1 1/4"	1 1/4"-11 1/2 NPTF	Brass
E10F10-S	1 1/2"	1 1/4"-11 1/2 NPTF	303 SS
E12F12	1 1/2"	1 1/2"-11 1/2 NPTF	Steel
E12F12-B	1 1/2"	1 1/2"-11 1/2 NPTF	Brass
E12F12-S	1 1/2"	1 1/2"-11 1/2 NPTF	303 SS
E16F16	2"	2"-11 1/2 NPTF	Steel
E16F16-B	2"	2"-11 1/2 NPTF	Brass
E16F16-S	2"	2"-11 1/2 NPTF	303 SS

Quick Release Couplings



(Male Thread)

E-SERIES STRAIGHT-THROUGH INTERCHANGE (COUPLER)

PART NO.	BODY SIZE	THREAD SIZE	BODY MATERIAL
1EM1-B	1/8"	1/8"-27 NPTF	Brass
1EM1-S	1/8"	1/8"-27 NPTF	303 SS
2EM2-B	1/4"	1/4"-18 NPTF	Brass
2EM2-S	1/4"	1/4"-18 NPTF	303 SS
3EM3-B	3/8"	3/8"-18 NPTF	Brass
3EM3-S	3/8"	3/8"-18 NPTF	303 SS
4EM4-B	1/2"	1/2"-14 NPTF	Brass
4EM4-S	1/2"	1/2"-14 NPTF	303 SS
6EM6-B	3/4"	3/4"-14 NPTF	Brass
6EM6-S	3/4"	3/4"-14 NPTF	303 SS
8EM8-B	1"	1"-11 1/2 NPTF	Brass
8EM8-S	1"	1"-11 1/2 NPTF	303 SS



(Male Thread)

E-SERIES STRAIGHT-THROUGH INTERCHANGE (NIPPLE)

PART NO.	BODY SIZE	THREAD SIZE	BODY MATERIAL
E1M1	1/8"	1/8"-27 NPTF	Steel
E1M1-B	1/8"	1/8"-27 NPTF	Brass
E1M1-S	1/8"	1/8"-27 NPTF	303 SS
E2M2	1/4"	1/4"-18 NPTF	Steel
E2M2-B	1/4"	1/4"-18 NPTF	Brass
E2M2-S	1/4"	1/4"-18 NPTF	303 SS
E3M3	3/8"	3/8"-18 NPTF	Steel
E3M3-B	3/8"	3/8"-18 NPTF	Brass
E3M3-S	3/8"	3/8"-18 NPTF	303 SS
E4M4	1/2"	1/2"-14 NPTF	Steel
E4M4-B	1/2"	1/2"-14 NPTF	Brass
E4M4-S	1/2"	1/2"-14 NPTF	303 SS
E6M6	3/4"	3/4"-14 NPTF	Steel
E6M6-B	3/4"	3/4"-14 NPTF	Brass
E6M6-S	3/4"	3/4"-14 NPTF	303 SS
E8M8	1"	1"-11 1/2 NPTF	Steel
E8M8-B	1"	1"-11 1/2 NPTF	Brass
E8M8-S	1"	1"-11 1/2 NPTF	303 SS
E10M10	1 1/4"	1 1/4"-11 1/2 NPTF	Steel
E10M10-B	1 1/4"	1 1/4"-11 1/2 NPTF	Brass
E12M12	1 1/2"	1 1/2"-11 1/2 NPTF	Steel
E12M12-B	1 1/2"	1 1/2"-11 1/2 NPTF	Brass
E16M16	2"	2"-11 1/2 NPTF	Steel
E16M16-B	2"	2"-11 1/2 NPTF	Brass



(Standard Hose Barb)

E-SERIES STRAIGHT-THROUGH INTERCHANGE (COUPLER)

PART NO.	BODY SIZE	BARB CONFIGURATION	BODY MATERIAL
2ES2-B	1/4"	1/4" Hose Barb	Brass
3ES3-B	3/8"	3/8" Hose Barb	Brass
4ES4-B	1/2"	1/2" Hose Barb	Brass
6ES6-B	3/4"	3/4" Hose Barb	Brass
8ES8-B	1"	1" Hose Barb	Brass



(Standard Hose Barb)

E-SERIES STRAIGHT-THROUGH INTERCHANGE (COUPLER)

PART NO.	BODY SIZE	BARB CONFIGURATION	BODY MATERIAL
E2S2	1/4"	1/4" Hose Barb	Steel
E2S2-B	1/4"	1/4" Hose Barb	Brass
E3S3	3/8"	3/8" Hose Barb	Steel
E3S3-B	3/8"	3/8" Hose Barb	Brass
E4S4	1/2"	1/2" Hose Barb	Steel
E4S4-B	1/2"	1/2" Hose Barb	Brass
E6S6	3/4"	3/4" Hose Barb	Steel
E6S6-B	3/4"	3/4" Hose Barb	Brass
E8S8	1"	1" Hose Barb	Steel
E8S8-B	1"	1" Hose Barb	Brass

EA-Series Water-Blast Interchange

- 'Maxi-Latch' retention system maximises nipple retention while reducing incidents of brinneling
- Nipple mounted sleeve guard protects against accidental disconnection
- Smooth bore full-flow design ensures maximum flow with minimal pressure drop
- Heavy duty knurled sleeves with locking pin provide maximum protection against brinneling and accidental disconnection
- Steel body components maximise service life by resisting the effects of brinneling and internal erosion



PERFORMANCE SPECIFICATIONS	OPERATING bar (psi)	MIN. BURST bar (psi)	FLOW RATE $\Delta P=1$ bar	LOCKING MECHANISM
1/2"	700 (10,000)	2,069 (30,000)	227 LPM (60 GPM)	Maxi-Latch
'EA' SERIES INTERCHANGE	PARKER	AEROQUIP	SNAP-TITE	-
1/2"	Series 'WB'	FD69	56-Series	-



(Female Thread)

EA-SERIES WATER-BLAST INTERCHANGE (COUPLER)

PART NO.	BODY SIZE	THREAD SIZE	BODY MATERIAL
4EAF3	1/2"	3/8"-18 NPTF	Steel
4EAF4	1/2"	1/2"-14 NPTF	Steel



(Female Thread)

EA-SERIES WATER-BLAST INTERCHANGE (NIPPLE)

PART NO.	BODY SIZE	THREAD SIZE	BODY MATERIAL
EA4F3	1/2"	3/8"-18 NPTF	Steel
EA4F4	1/2"	1/2"-14 NPTF	Steel

CM-Series Mould Coolant Interchange

- Non-Valved straight-through couplers are available to maximise flow performance
- Valved couplers provide automatic shut-off upon disconnection to avoid fluid loss while hoses are not coupled
- Silicone sealing gaskets are standard and will optimise performance in coolant applications. Range: -68°C to +205°C (-90°F to +400°F)
- Wide variety of sizes and end configurations ensures versatility in a wide variety of applications
- Highly durable and corrosion resistant materials will optimise longevity and improve performance



PERFORMANCE SPECIFICATIONS	OPERATING bar (psi)	BURST bar (psi)	UNVALVED FLOW RATE	VALVED FLOW RATE
1/4"	14 (200)	69 (1,000)	23 LPM (6 GPM)	13 LPM (3.5 GPM)
3/8"	14 (200)	69 (1,000)	50 LPM (13 GPM)	26 LPM (7 GPM)
1/2"	14 (200)	69 (1,000)	132 LPM (35 GPM)	76 LPM (20 GPM)

'CM' SERIES INTERCHANGE	FOSTER	HANSEN	TOMCO	PARKER
1/4"	Series 'FJT'	Flo-Temp	MC200	Moldmate
3/8"	Series 'FJT'	Flo-Temp	MC300	Moldmate
1/2"	Series 'FJT'	Flo-Temp	MC500	Moldmate

CM-SERIES INDUSTRIAL MOULD INTERCHANGE (NIPPLE)



(Female Thread)

PART NO.	BODY SIZE	THREAD SIZE	BODY MATERIAL
CM2F1	1/4"	1/8"-27 NPT	Steel
CM2F1-B	1/4"	1/8"-27 NPT	Brass
CM2F2	1/4"	1/4"-18 NPT	Steel
CM2F2-B	1/4"	1/4"-18 NPT	Brass
CM2F3	1/4"	3/8"-18 NPT	Steel
CM2F3-B	1/4"	3/8"-18 NPT	Brass
CM3F2	3/8"	1/4"-18 NPT	Steel
CM3F2-B	3/8"	1/4"-18 NPT	Brass
CM3F3	3/8"	3/8"-18 NPT	Steel
CM3F3-B	3/8"	3/8"-18 NPT	Brass
CM4F4-B	1/2"	1/2"-14 NPT	Brass
CM4F6-B	1/2"	3/4"-14 NPT	Brass



(Male Thread)

PART NO.	BODY SIZE	THREAD SIZE	BODY MATERIAL
CM2M1-B	1/4"	1/8"-27 NPT	Brass
CM2M2-B	1/4"	1/4"-18 NPT	Brass
CM2M3-B	1/4"	3/8"-18 NPT	Brass
CM3M2-B	3/8"	1/4"-18 NPT	Brass
CM3M3-B	3/8"	3/8"-18 NPT	Brass
CM3M4-B	3/8"	1/2"-14 NPT	Brass
CM4M4-B	1/2"	1/2"-14 NPT	Brass
CM4M6-B	1/2"	3/4"-14 NPT	Brass

Quick Release Couplings

Counterbored mould ports will protect the male threaded nipple, allowing the nipple to be mounted below the surface, simplifying storing and handling of moulds. Perfecting male threaded plugs are constructed of corrosion resistant Brass to maximise longevity in moist environments.

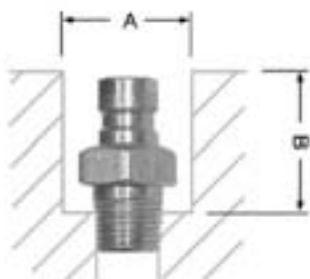

PART NO.	BODY SIZE	THREAD SIZE	DIMENSION 'A'	DIMENSION 'B'
CM2M1-B	1/4"	1/8"-27 NPT	17.5mm (0.69")	17.5mm (0.69")
CM2M2-B	1/4"	1/4"-18 NPT	21.3mm (0.84")	23.9mm (0.94")
CM2M3-B	1/4"	3/8"-18 NPT	25.4mm (1.00")	24.6mm (0.97")
CM3M2-B	3/8"	1/4"-18 NPT	17.5mm (0.69")	23.9mm (0.94")
CM3M3-B	3/8"	3/8"-18 NPT	21.3mm (0.84")	28.7mm (1.13")
CM3M4-B	3/8"	1/2"-14 NPT	25.4mm (1.00")	31.8mm (1.25")
CM4M4-B	1/2"	1/2"-14 NPT	31.8mm (1.25")	38.1mm (1.50")
CM4M6-B	1/2"	3/4"-14 NPT	38.1mm (1.50")	39.6mm (1.56")



(Female Thread)

CM-SERIES INDUSTRIAL MOULD INTERCHANGE (UNVALVED COUPLER)

PART NO.	BODY SIZE	THREAD SIZE	BODY MATERIAL
2CMF1-B-E	1/4"	1/8"-27 NPT	Brass
3CMF2-B-E	3/8"	1/4"-18 NPT	Brass
4CMF4-B-E	1/2"	1/2"-14 NPT	Brass



(Standard & Push-Loc Hose Barb)

CM-SERIES INDUSTRIAL MOULD INTERCHANGE (UNVALVED COUPLER)

PART NO.	BODY SIZE	BARB CONFIGURATION	BODY MATERIAL
2CMS2-B-E	1/4"	1/4" Hose Barb	Brass
2CMB2-B-E	1/4"	1/4" Push-Loc	Brass
2CMS2.5-B-E	1/4"	5/16" Hose Barb	Brass
2CMS3-B-E	1/4"	3/8" Hose Barb	Brass
2CMB3-B-E	1/4"	3/8" Push-Loc	Brass
3CMS3-B-E	3/8"	3/8" Hose Barb	Brass
3CMB3-B-E	3/8"	3/8" Push-Loc	Brass
3CMS4-B-E	3/8"	1/2" Hose Barb	Brass
3CMB4-B-E	3/8"	1/2" Push-Loc	Brass
4CMS4-B-E	1/2"	1/2" Hose Barb	Brass
4CMB4-B-E	1/2"	1/2" Push-Loc	Brass
4CMS6-B-E	1/2"	3/4" Hose Barb	Brass



(Standard & Push-Loc Hose Barb)

CM-SERIES INDUSTRIAL MOULD INTERCHANGE (UNVALVED 45° COUPLER)

PART NO.	BODY SIZE	BARB CONFIGURATION	BODY MATERIAL
2CM4S2-B-E	1/4"	1/4" Hose Barb	Brass
2CM4B2-B-E	1/4"	1/4" Push-Loc	Brass
2CM4S2.5-B-E	1/4"	5/16" Hose Barb	Brass
2CM4S3-B-E	1/4"	3/8" Hose Barb	Brass
2CM4B3-B-E	1/4"	3/8" Push-Loc	Brass
3CM4S3-B-E	3/8"	3/8" Hose Barb	Brass
3CM4B3-B-E	3/8"	3/8" Push-Loc	Brass
3CM4S4-B-E	3/8"	1/2" Hose Barb	Brass
3CM4B4-B-E	3/8"	1/2" Push-Loc	Brass
4CM4S4-B-E	1/2"	1/2" Hose Barb	Brass
4CM4B4-B-E	1/2"	1/2" Push-Loc	Brass
4CM4S6-B-E	1/2"	3/4" Hose Barb	Brass

Quick Release Couplings



(Standard & Push-Loc Hose Barb)

CM-SERIES INDUSTRIAL MOULD INTERCHANGE (UNVALVED 90° COUPLER)

PART NO.	BODY SIZE	BARB CONFIGURATION	BODY MATERIAL
2CM9S2-B-E	1/4"	1/4" Hose Barb	Brass
2CM9B2-B-E	1/4"	1/4" Push-Loc	Brass
2CM9S2.5-B-E	1/4"	5/16" Hose Barb	Brass
2CM9S3-B-E	1/4"	3/8" Hose Barb	Brass
2CM9B3-B-E	1/4"	3/8" Push-Loc	Brass
3CM9S3-B-E	3/8"	3/8" Hose Barb	Brass
3CM9B3-B-E	3/8"	3/8" Push-Loc	Brass
3CM9S4-B-E	3/8"	1/2" Hose Barb	Brass
3CM9B4-B-E	3/8"	1/2" Push-Loc	Brass
4CM9S4-B-E	1/2"	1/2" Hose Barb	Brass
4CM9B4-B-E	1/2"	1/2" Push-Loc	Brass
4CM9S6-B-E	1/2"	3/4" Hose Barb	Brass



CM-SERIES INDUSTRIAL MOULD INTERCHANGE (VALVED COUPLER)

PART NO.	BODY SIZE	THREAD SIZE	BODY MATERIAL
2CMF1-B	1/4"	1/8"-27 NPT	Brass
3CMF2-B	1/4"	1/4"-18 NPT	Brass



(Standard & Push-Loc Hose Barb)

CM-SERIES INDUSTRIAL MOULD INTERCHANGE (VALVED COUPLER)

PART NO.	BODY SIZE	BARB CONFIGURATION	BODY MATERIAL
2CMS2-B	1/4"	1/4" Hose Barb	Brass
2CMB2-B	1/4"	1/4" Push-Loc	Brass
2CMS2.5-B	1/4"	5/16" Hose Barb	Brass
2CMS3-B	1/4"	3/8" Hose Barb	Brass
2CMB3-B	1/4"	3/8" Push-Loc	Brass
3CMS3-B	3/8"	3/8" Hose Barb	Brass
3CMB3-B	3/8"	3/8" Push-Loc	Brass
3CMS4-B	3/8"	1/2" Hose Barb	Brass
3CMB4-B	3/8"	1/2" Push-Loc	Brass



(Standard & Push-Loc Hose Barb)

CM-SERIES INDUSTRIAL MOULD INTERCHANGE (VALVED 45° COUPLER)

PART NO.	BODY SIZE	BARB CONFIGURATION	BODY MATERIAL
2CM4S2-B	1/4"	1/4" Hose Barb	Brass
2CM4B2-B	1/4"	1/4" Push-Loc	Brass
2CM4S2.5-B	1/4"	5/16" Hose Barb	Brass
2CM4S3-B	1/4"	3/8" Hose Barb	Brass
2CM4B3-B	1/4"	3/8" Push-Loc	Brass
3CM4S3-B	3/8"	3/8" Hose Barb	Brass
3CM4B3-B	3/8"	3/8" Push-Loc	Brass
3CM4S4-B	3/8"	1/2" Hose Barb	Brass
3CM4B4-B	3/8"	1/2" Push-Loc	Brass



(Standard & Push-Loc Hose Barb)

CM-SERIES INDUSTRIAL MOULD INTERCHANGE (VALVED 45° COUPLER)

PART NO.	BODY SIZE	BARB CONFIGURATION	BODY MATERIAL
2CM9S2-B	1/4"	1/4" Hose Barb	Brass
2CM9B2-B	1/4"	1/4" Push-Loc	Brass
2CM9S2.5-B	1/4"	5/16" Hose Barb	Brass
2CM9S3-B	1/4"	3/8" Hose Barb	Brass
2CM9B3-B	1/4"	3/8" Push-Loc	Brass
3CM9S3-B	3/8"	3/8" Hose Barb	Brass
3CM9B3-B	3/8"	3/8" Push-Loc	Brass
3CM9S4-B	3/8"	1/2" Hose Barb	Brass
3CM9B4-B	3/8"	1/2" Push-Loc	Brass

DF-Series Industrial Interchange

- D-Series couplers provide convenient automatic one-handed connection and safe disconnection
- All couplers have a high concentration of locking balls to reduce incidents of brinelling during operation
- D-Series couplers have a reverse-acting sleeve to prevent accidental disconnection and prevent whip during disconnection.
- F-Series couplers have a sleeve-guard 'Lip' to reduce the risk of accidental disconnection while in service
- F-Series couplers, D-Series couplers and DF-Series nipples are available in a variety of material configurations



PERFORMANCE SPECIFICATIONS	OPERATING BAR (psi)	MIN. BURST BAR (psi)	FLOW RATE ΔP=1 BAR	LOCKING MECHANISM
1/4"	69 (1,000)	310 (4,500)	37 CFM	6 Balls
3/8"	69 (1,000)	276 (4,000)	70 CFM	6 Balls
1/2"	69 (1,000)	414 (6,000)	150 CFM	6 Balls
3/4"	21 (300)	138 (2,000)	200 CFM	6 Balls

INTERCHANGE SPECIFICATIONS	US MILITARY	US GOVERNMENT	INTERNATIONAL STANDARDS	ANSI/NFPA
1/4"	MIL-C-4109F	A-A-59439	ISO 6150B	T3.20.14-1990
3/8"	X	X	ISO 6150B	T3.20.14-1990
1/2"	MIL-C-4109F	A-A-59439	ISO 6150B	T3.20.14-1990
3/4"	X	X	X	T3.20.14-1990

x These particular sizes are not outlined within the documented standard category.

'D' COUPLER	PARKER	HANSEN	RECTUS	ANSI/NFPA
1/4"	Parker 30	Hansen 3000	Rectus 23KA/24KA	Cejn 310
3/8"	Parker 30	Hansen 4000	Rectus 30KA	Cejn 430
1/2"	Parker 30	Hansen 5000	Rectus 37KA	Cejn 550
3/4"	Parker 30	Hansen 6000	-	-

'F' COUPLER	PARKER	HANSEN	TOMCO	RECTUS
1/4"	Parker 20	Hansen 1000	Tomco A180	Rectus 24KM
3/8"	Parker 20	Hansen 400	Tomco PT400	Rectus 30KM
1/2"	Parker 20	Hansen 500	Tomco T500	Rectus 37K

Quick Release Couplings



(Reusable Barb)

D-SERIES INDUSTRIAL INTERCHANGE (AUTOMATIC SAFETY COUPLER)

PART NO.	BODY SIZE	BARB CONFIGURATION	BODY MATERIAL
2DE2-B	1/4"	1/4" ID X 1/2" OD	Brass
2DH2-B	1/4"	1/4" ID X 5/8" OD	Brass
2DH2-S	1/4"	1/4" ID X 5/8" OD	303 Stainless Steel
2DK3-B	1/4"	3/8" ID X 11/16" OD	Brass
2DL3-B	1/4"	3/8" ID X 3/4" OD	Brass



(Reusable Barb)

F-SERIES INDUSTRIAL INTERCHANGE (MANUAL COUPLER)

PART NO.	BODY SIZE	BARB CONFIGURATION	BODY MATERIAL
2FE2-B	1/4"	1/4" ID X 1/2" OD	Brass
2FH2-B	1/4"	1/4" ID X 5/8" OD	Brass
2FH2-S	1/4"	1/4" ID X 5/8" OD	303 Stainless Steel
2FK3-B	1/4"	3/8" ID X 11/16" OD	Brass
2FL3-B	1/4"	3/8" ID X 3/4" OD	Brass



(Reusable Barb)

DF-SERIES INDUSTRIAL INTERCHANGE (NIPPLE)

PART NO.	BODY SIZE	BARB CONFIGURATION	BODY MATERIAL
D2E2	1/4"	1/4" ID X 1/2" OD	Brass
D2H2	1/4"	1/4" ID X 5/8" OD	Brass
D2H2-S	1/4"	1/4" ID X 5/8" OD	303 Stainless Steel
D2K3	1/4"	3/8" ID X 11/16" OD	Brass
D2L3	1/4"	3/8" ID X 3/4" OD	Brass



(Female Thread)

D-SERIES INDUSTRIAL INTERCHANGE (AUTOMATIC SAFETY COUPLER)

PART NO.	BODY SIZE	THREAD SIZE	BODY MATERIAL
2DF1-B	1/4"	1/8"-27 NPTF	Brass
2DF2-B	1/4"	1/4"-18 NPTF	Brass
2DF2-S	1/4"	1/4"-18 NPTF	303 Stainless Steel
2DBF2-B	1/4"	G1/4" BSPP	Brass
2DF3-B	1/4"	3/8"-18 NPTF	Brass
2DBF3-B	1/4"	G3/8" BSPP	Brass
3DF2-B	3/8"	1/4"-18 NPTF	Brass
3DF3-B	3/8"	3/8"-18 NPTF	Brass
3DF3-S	3/8"	3/8"-18 NPTF	303 Stainless Steel
3DBF3-B	3/8"	G3/8" BSPP	Brass
3DF4-B	3/8"	1/2"-14 NPTF	Brass
4DF3-B	1/2"	3/8"-18 NPTF	Brass
4DF4-B	1/2"	1/2"-14 NPTF	Brass
4DF4-S	1/2"	1/2"-14 NPTF	303 Stainless Steel
4DBF4-B	1/2"	G1/2" BSPP	Brass
4DF6-B	1/2"	3/4"-14 NPTF	Brass
6DF4-B	3/4"	1/2"-14 NPTF	Brass
6DF6-B	3/4"	3/4"-14 NPTF	Brass
6DF8-B	3/4"	1"-11 1/2 NPTF	Brass

F-SERIES INDUSTRIAL INTERCHANGE (MANUAL COUPLER)



(Female Thread)

PART NO.	BODY SIZE	THREAD SIZE	BODY MATERIAL
2FF1-B	1/4"	1/8"-27 NPTF	Brass
2FBF1-B	1/4"	G1/8" BSPP	Brass
2FF2-B	1/4"	1/4"-18 NPTF	Brass
2FF2	1/4"	1/4"-18 NPTF	Steel
2FF2-S	1/4"	1/4"-18 NPTF	303 Stainless Steel
2FBF2-B	1/4"	G1/4" BSPP	Brass
2FF3-B	1/4"	3/8"-18 NPTF	Brass
2FBF3-B	1/4"	G3/8" BSPP	Brass
3FF2	3/8"	1/4"-18 NPTF	Steel
3FF3	3/8"	3/8"-18 NPTF	Steel
3FF3-S	3/8"	3/8"-18 NPTF	303 Stainless Steel
3FBF3	3/8"	G3/8" BSPP	Steel
3FF4	3/8"	1/2"-14 NPTF	Steel
4FF3	1/2"	3/8"-18 NPTF	Steel
4FF4	1/2"	1/2"-14 NPTF	Steel
4FF4-S	1/2"	1/2"-14 NPTF	303 Stainless Steel
4FBF4	1/2"	G1/2" BSPP	Steel
4FF6	1/2"	3/4"-14 NPTF	Steel

DF-SERIES INDUSTRIAL INTERCHANGE (NIPPLE)



(Female Thread)

PART NO.	BODY SIZE	THREAD SIZE	BODY MATERIAL
D2F1	1/4"	1/8"-27 NPTF	Steel
D2F2	1/4"	1/4"-18 NPTF	Steel
D2F2-B	1/4"	1/4"-18 NPTF	Brass
D2F2-S	1/4"	1/4"-18 NPTF	303 Stainless Steel
D2BF2	1/4"	G1/4" BSPP	Steel
D2F3	1/4"	3/8"-18 NPTF	Steel
D2F3-B	1/4"	3/8"-18 NPTF	Brass
D2BF3	1/4"	G3/8" BSPPT	Steel
D3F2	3/8"	1/4"-18 NPTF	Steel
D3F3	3/8"	3/8"-18 NPTF	Steel
D3F3-B	3/8"	3/8"-18 NPTF	Brass
D3F3-S	3/8"	3/8"-18 NPTF	303 Stainless Steel
D3BF3	3/8"	G3/8" BSPP	Steel
D3F4	3/8"	1/2"-14 NPTF	Steel
D4F3	1/2"	3/8"-18 NPTF	Steel
D4F4	1/2"	1/2"-14 NPTF	Steel
D4F4-B	1/2"	1/2"-14 NPTF	Brass
D4F4-S	1/2"	1/2"-14 NPTF	303 Stainless Steel
D4BF4	1/2"	G1/2" BSPP	Steel
D4F6	1/2"	3/4"-14 NPTF	Steel
D6F4	3/4"	1/2"-14 NPTF	Steel
D6F6	3/4"	3/4"-14 NPTF	Steel
D6F8	3/4"	1"-11 1/2 NPTF	Steel

Quick Release Couplings



(Male Thread)

D-SERIES INDUSTRIAL INTERCHANGE (AUTOMATIC SAFETY COUPLER)

PART NO.	BODY SIZE	THREAD SIZE	BODY MATERIAL
2DM1-B	1/4"	1/8"-27 NPTF	Brass
2DM2-B	1/4"	1/4"-18 NPTF	Brass
2DM2-S	1/4"	1/4"-18 NPTF	303 Stainless Steel
2DBM2-B	1/4"	R1/4" BSPT	Brass
2DM3-B	1/4"	3/8"-18 NPTF	Brass
2DBM3-B	1/4"	R3/8" BSPT	Brass
3DM2-B	3/8"	1/4"-18 NPTF	Brass
3DM3-B	3/8"	3/8"-18 NPTF	Brass
3DM3-S	3/8"	3/8"-18 NPTF	303 Stainless Steel
3DBM3-B	3/8"	R3/8" BSPT	Brass
3DM4-B	3/8"	1/2"-14 NPTF	Brass
4DM3-B	1/2"	3/8"-18 NPTF	Brass
4DM4-B	1/2"	1/2"-14 NPTF	Brass
4DM4-S	1/2"	1/2"-14 NPTF	303 Stainless Steel
4DBM4-B	1/2"	R1/2" BSPT	Brass
4DM6-B	1/2"	3/4"-14 NPTF	Brass
6DM4-B	3/4"	1/2"-14 NPTF	Brass
6DM6-B	3/4"	3/4"-14 NPTF	Brass
6DM8-B	3/4"	1"-11 1/2 NPTF	Brass

F-SERIES INDUSTRIAL INTERCHANGE (MANUAL COUPLER)

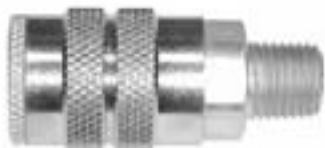

(Male Thread)

PART NO.	BODY SIZE	THREAD SIZE	BODY MATERIAL
2FM1-B	1/4"	1/8"-27 NPTF	Brass
2FM1-S	1/4"	1/8"-27 NPTF	303 Stainless Steel
2FM2-B	1/4"	1/4"-18 NPTF	Brass
2FM2	1/4"	1/4"-18 NPTF	Brass
2FM2-S	1/4"	1/4"-18 NPTF	303 Stainless Steel
2FBM2-B	1/4"	R1/4" BSPT	Brass
2FM3-B	1/4"	3/8"-18 NPTF	Brass
2FBM3-B	1/4"	R3/8" BSPT	Brass
3FM2	3/8"	1/4"-18 NPTF	Steel
3FM3	3/8"	3/8"-18 NPTF	Steel
3FM3-S	3/8"	3/8"-18 NPTF	303 Stainless Steel
3FBM3	3/8"	R3/8" BSPT	Steel
3FM4	3/8"	1/2"-14 NPTF	Steel
4FM3	1/2"	3/8"-18 NPTF	Steel
4FM4	1/2"	1/2"-14 NPTF	Steel
4FM4-S	1/2"	1/2"-14 NPTF	303 Stainless Steel
4FBM4	1/2"	R1/2" BSPT	Steel
4FM6	1/2"	3/4"-14 NPTF	Steel

DF-SERIES INDUSTRIAL INTERCHANGE (NIPPLE)



(Male Thread)

PART NO.	BODY SIZE	THREAD SIZE	BODY MATERIAL
D2M1	1/4"	1/8"-27 NPTF	Steel
D2M1-B	1/4"	1/8"-27 NPTF	Steel
D2M1-S	1/4"	1/8"-27 NPTF	303 Stainless Steel
D2M2	1/4"	1/4"-18 NPTF	Steel
D2M2-B	1/4"	1/4"-18 NPTF	Brass
D2M2-S	1/4"	1/4"-18 NPTF	303 Stainless Steel
D2BM2	1/4"	R1/4" BSPT	Steel
D2M3	1/4"	3/8"-18 NPTF	Steel
D2M3-B	1/4"	3/8"-18 NPTF	Brass
D2BM3	1/4"	R3/8" BSPT	Steel
D3M2	3/8"	1/4"-18 NPTF	Steel
D3M3	3/8"	3/8"-18 NPTF	Steel
D3M3-B	3/8"	3/8"-18 NPTF	Brass
D3M3-S	3/8"	3/8"-18 NPTF	303 Stainless Steel
D3BM3	3/8"	R3/8" BSPT	Steel
D3M4	3/8"	1/2"-14 NPTF	Steel
D4M2	1/2"	1/4"-18 NPTF	Steel
D4M3	1/2"	3/8"-18 NPTF	Steel
D4M4	1/2"	1/2"-14 NPTF	Steel
D4M4-B	1/2"	1/2"-14 NPTF	Brass
D4M4-S	1/2"	1/2"-14 NPTF	303 Stainless Steel
D4BM4	1/2"	R1/2" BSPT	Steel
D4M6	1/2"	3/4"-14 NPTF	Steel
D6M4	3/4"	1/2"-14 NPTF	Steel
D6M6	3/4"	3/4"-14 NPTF	Steel
D6M8	3/4"	1"-11 1/2 NPTF	Steel

D-SERIES INDUSTRIAL INTERCHANGE (AUTOMATIC SAFETY COUPLER)



(Standard and Push-Loc Hose Barb)

PART NO.	BODY SIZE	BARB CONFIGURATION	BODY MATERIAL
2DS2-B	1/4"	1/4" Hose Barb	Brass
2DS2-S	1/4"	1/4" Hose Barb	303 Stainless Steel
2DB2-B	1/4"	1/4" Push-Loc	Brass
2DS2.5-B	1/4"	5/16" Hose Barb	Brass
2DS3-B	1/4"	3/8" Hose Barb	Brass
2DB3-B	1/4"	3/8" Push-Loc	Brass
3DS2-B	3/8"	1/4" Hose Barb	Brass
3DS3-B	3/8"	3/8" Hose Barb	Brass
3DS3-S	3/8"	3/8" Hose Barb	303 Stainless Steel
3DB3-B	3/8"	3/8" Push-Loc	Brass
3DS4-B	3/8"	1/2" Hose Barb	Brass
4DS3-B	1/2"	3/8" Hose Barb	Brass
4DS4-B	1/2"	1/2" Hose Barb	Brass
4DS4-S	1/2"	1/2" Hose Barb	303 Stainless Steel
4DB4-B	1/2"	1/2" Hose Barb	Brass
4DS6-B	1/2"	3/4" Hose Barb	Brass
6DS4-B	3/4"	1/2" Hose Barb	Brass
6DS6-B	3/4"	3/4" Hose Barb	Brass
6DS8-B	3/4"	1" Hose Barb	Brass

Quick Release Couplings



(Standard and Push-Loc Hose Barb)

F-SERIES INDUSTRIAL INTERCHANGE (MANUAL COUPLER)

PART NO.	BODY SIZE	BARB CONFIGURATION	BODY MATERIAL
2FS2-B	1/4"	1/4" Hose Barb	Brass
2FS2-S	1/4"	1/4" Hose Barb	303 Stainless Steel
2FB2-B	1/4"	1/4" Push-Loc	Brass
2FS2.5-B	1/4"	5/16" Hose Barb	Brass
2FS3-B	1/4"	3/8" Hose Barb	Brass
2FB3-B	1/4"	3/8" Push-Loc	Brass
3FS2	3/8"	1/4" Hose Barb	Steel
3FS3	3/8"	3/8" Hose Barb	Steel
3FS3-S	3/8"	3/8" Hose Barb	303 Stainless Steel
3FB3	3/8"	3/8" Push-Loc	Steel
3FS4	3/8"	1/2" Hose Barb	Steel
4FS3	1/2"	3/8" Hose Barb	Steel
4FS4	1/2"	1/2" Hose Barb	Steel
4FS4-S	1/2"	1/2" Hose Barb	303 Stainless Steel
4FB4	1/2"	1/2" Push-Loc	Steel
4FS6	1/2"	3/4" Hose Barb	Steel

DF-SERIES INDUSTRIAL INTERCHANGE (NIPPLE)



(Standard and Push-Loc Hose Barb)

PART NO.	BODY SIZE	BARB CONFIGURATION	BODY MATERIAL
D2S2	1/4"	1/4" Hose Barb	Steel
D2S2-B	1/4"	1/4" Hose Barb	Brass
D2S2-S	1/4"	1/4" Hose Barb	303 Stainless Steel
D2B2	1/4"	1/4" Push-Loc	Steel
D2S2.5	1/4"	5/16" Hose Barb	Steel
D2S3	1/4"	3/8" Hose Barb	Steel
D2S3-B	1/4"	3/8" Hose Barb	Brass
D2B3	1/4"	3/8" Push-Loc	Steel
D3S2	3/8"	1/4" Hose Barb	Steel
D3S3	3/8"	3/8" Hose Barb	Steel
D3S3-B	3/8"	3/8" Hose Barb	Brass
D3S3-S	3/8"	3/8" Hose Barb	303 Stainless Steel
D3B3	3/8"	3/8" Push-Loc	Steel
D3S4	3/8"	1/2" Hose Barb	Steel
D4S3	1/2"	3/8" Hose Barb	Steel
D4S4	1/2"	1/2" Hose Barb	Steel
D4S4-B	1/2"	1/2" Hose Barb	Brass
D4S4-S	1/2"	1/2" Hose Barb	303 Stainless Steel
D4B4	1/2"	1/2" Push-Loc	Steel
D4S6	1/2"	3/4" Hose Barb	Steel
D6S4	3/4"	1/2" Hose Barb	Steel
D6S6	3/4"	3/4" Hose Barb	Steel
D6S8	3/4"	1" Hose Barb	Steel

BR-Series Rectus '21' Interchange

- High concentration of balls reduces incidents of brinelling during operation
- Couplers and nipples are constructed of plated brass to maximise corrosion resistance
- Coupler valve has been designed to work with valved and/or unvalved nipple configurations



PERFORMANCE SPECIFICATIONS	OPERATING BAR (psi)	BURST BAR (psi)	FLOW ΔP=0.4 BAR (6.9 BAR INLET)	LOCKING MECHANISM
1/8"	21 (300)	138 (2,000)	17 CFM	6 Balls

'BR' SERIES INTERCHANGE	TOMCO	CAMOZZI	CEJN	RECTUS
1/8"	Series SC	Series 5000	Series 223	21KA



(Female Thread)

BR-SERIES RECTUS '21' INTERCHANGE (AUTOMATIC COUPLER)

PART NO.	BODY SIZE	THREAD SIZE	BODY MATERIAL
1BRF1-B-7	1/8"	1/8"-27 NPTF	Brass
1BRBF1-B-7	1/8"	G1/8" BSPP	Brass
1BRF2-B-7	1/8"	1/4"-18 NPTF	Brass
1BRBF2-B-7	1/8"	G1/4" BSPP	Brass



(Female Thread)

BR-SERIES RECTUS '21' INTERCHANGE (UNVALVED NIPPLE)

PART NO.	BODY SIZE	THREAD SIZE	BODY MATERIAL
BR1F1-B-E-7	1/8"	1/8"-27 NPTF	Brass
BR1BF1-B-E-7	1/8"	G1/8" BSPP	Brass
BR1F2-B-E-7	1/8"	1/4"-18 NPTF	Brass
BR1BF2-B-E-7	1/8"	G1/4" BSPP	Brass

Quick Release Couplings



(Male Thread)

BR-SERIES RECTUS '21' INTERCHANGE (AUTOMATIC COUPLER)

PART NO.	BODY SIZE	THREAD SIZE	BODY MATERIAL
1BRM1-B-7	1/8"	1/8"-27 NPTF	Brass
1BRGM1-B-7	1/8"	G1/8" BSPP	Brass
1BRM2-B-7	1/8"	1/4"-18 NPTF	Brass
1BRGM2-B-7	1/8"	G1/4" BSPP	Brass



(Male Thread)

BR-SERIES RECTUS '21' INTERCHANGE (UNVALVED NIPPLE)

PART NO.	BODY SIZE	THREAD SIZE	BODY MATERIAL
BR1M1-B-E-7	1/8"	1/8"-27 NPTF	Brass
BR1GM1-B-E-7	1/8"	G1/8" BSPP	Brass
BR1M2-B-E-7	1/8"	1/4"-18 NPTF	Brass
BR1GM2-B-E-7	1/8"	G1/4" BSPP	Brass



(Standard Hose Barb)

BR-SERIES RECTUS '21' INTERCHANGE (AUTOMATIC COUPLER)

PART NO.	BODY SIZE	BARB CONFIGURATION	BODY MATERIAL
1BRS1.25-B-7	1/8"	4mm Hose Barb	Brass
1BRS1.88-B-7	1/8"	6mm Hose Barb	Brass
1BRS2.83-B-7	1/8"	9mm Hose Barb	Brass



(Standard Hose Barb)

BR-SERIES RECTUS '21' INTERCHANGE (UNVALVED NIPPLE)

PART NO.	BODY SIZE	BARB CONFIGURATION	BODY MATERIAL
BR1S1.25-B-E-7	1/8"	4mm Hose Barb	Brass
BR1S1.88-B-E-7	1/8"	6mm Hose Barb	Brass
BR1S2.83-B-E-7	1/8"	9mm Hose Barb	Brass

J-Series Truflate Automotive Interchange

- The J-Series is fully interchangeable with the Parker Truflate series, sizes 1/4" to 1/2"
- 1/4" J-Series couplers are made of brass with a steel sleeve and are available in all brass or brass flanged sleeve configurations
- 3/8" and 1/2" couplers are constructed of plated steel to maximise performance and durability
- Couplers have a sleeve-guard 'Lip' to reduce the risk of accidental disconnection while in service



PERFORMANCE SPECIFICATIONS	OPERATING BAR (psi)	BURST BAR (psi)	FLOW ΔP=0.4 BAR (6.9 BAR INLET)	LOCKING MECHANISM
1/4"	34 (500)	233 (3,380)	37 CFM	6 Balls
3/8"	34 (500)	276 (4,000)	70 CFM	6 Balls
1/2"	34 (500)	414 (6,000)	150 CFM	6 Balls

'J' SERIES INTERCHANGE	PARKER	TOMCO	COILHOSE	RECTUS
1/4"	10-Series	A2100	Type '16'	55KM
3/8"	10-Series	PT400	Type '59'	-
1/2"	10-Series	-	-	-

J-SERIES TRUFLATE AUTOMOTIVE INTERCHANGE (MANUAL COUPLER)

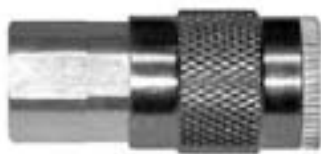

(Female Thread)

PART NO.	BODY SIZE	THREAD SIZE	BODY MATERIAL
2JF1-B	1/4"	1/8"-27 NPTF	Brass
2JF2-B	1/4"	1/4"-18 NPTF	Brass
2JBF2-B	1/4"	G1/4" BSPP	Brass
2JF3-B	1/4"	3/8"-18 NPTF	Brass
3JF2	3/8"	1/4"-18 NPTF	Steel
3JF3	3/8"	3/8"-18 NPTF	Steel
3JBF3	3/8"	G3/8" BSPP	Steel
3JF4	3/8"	1/2"-14 NPTF	Steel
4FF3	1/2"	3/8"-18 NPTF	Steel
4FF4	1/2"	1/2"-14 NPTF	Steel
4FBF4	1/2"	G1/2" BSPP	Steel
4FF6	1/2"	3/4"-14 NPTF	Steel

Quick Release Couplings



(Female Thread)

J-SERIES TRUFLATE AUTOMOTIVE INTERCHANGE (NIPPLE)

PART NO.	BODY SIZE	THREAD SIZE	BODY MATERIAL
J2F1	1/4"	1/8"-27 NPTF	Steel
J2F2	1/4"	1/4"-18 NPTF	Steel
J2F2-B	1/4"	1/4"-18 NPTF	Brass
J2BF2	1/4"	G1/4" BSPP	Steel
J2F3	1/4"	3/8"-18 NPTF	Steel
J3F2	3/8"	1/4"-18 NPTF	Steel
J3F3	3/8"	3/8"-18 NPTF	Steel
J3BF3	3/8"	G3/8" BSPP	Steel
J3F4	3/8"	1/2"-14 NPTF	Steel
J4F3	1/2"	3/8"-18 NPTF	Steel
J4F4	1/2"	1/2"-14 NPTF	Steel
J4BF4	1/2"	G1/2" BSPP	Steel
J4F6	1/2"	3/4"-14 NPTF	Steel



(Male Thread)

J-SERIES TRUFLATE AUTOMOTIVE INTERCHANGE (MANUAL COUPLER)

PART NO.	BODY SIZE	THREAD SIZE	BODY MATERIAL
2JM1-B	1/4"	1/8"-27 NPTF	Brass
2JM2-B	1/4"	1/4"-18 NPTF	Brass
2JM3-B	1/4"	3/8"-18 NPTF	Brass
3JM2	3/8"	1/4"-18 NPTF	Steel
3JM3	3/8"	3/8"-18 NPTF	Steel
3JM4	3/8"	1/2"-14 NPTF	Steel
4FM3	1/2"	3/8"-18 NPTF	Steel
4FM4	1/2"	1/2"-14 NPTF	Steel
4FM6	1/2"	3/4"-14 NPTF	Steel



(Male Thread)

J-SERIES TRUFLATE AUTOMOTIVE INTERCHANGE (NIPPLE)

PART NO.	BODY SIZE	THREAD SIZE	BODY MATERIAL
J2M1	1/4"	1/8"-27 NPTF	Steel
J2M2	1/4"	1/4"-18 NPTF	Steel
J2M2-B	1/4"	1/4"-18 NPTF	Brass
J2M3	1/4"	3/8"-18 NPTF	Steel
J3M2	3/8"	1/4"-18 NPTF	Steel
J3M3	3/8"	3/8"-18 NPTF	Steel
J3M4	3/8"	1/2"-14 NPTF	Steel
J4M3	1/2"	3/8"-18 NPTF	Steel
J4M4	1/2"	1/2"-14 NPTF	Steel
J4M6	1/2"	3/4"-14 NPTF	Steel



(Standard & Push-Loc Hose Barb)

J-SERIES TRUFLATE AUTOMOTIVE INTERCHANGE (MANUAL COUPLER)

PART NO.	BODY SIZE	BARB CONFIGURATION	BODY MATERIAL
2JS2-B	1/4"	1/4" Hose Barb	Brass
2JB2-B	1/4"	1/4" Push-Loc	Brass
2JS2.5-B	1/4"	5/16" Hose Barb	Brass
2JS3-B	1/4"	3/8" Hose Barb	Brass
2JB3-B	1/4"	3/8" Push-Loc	Brass
3JS2	3/8"	1/4" Hose Barb	Steel
3JS3	3/8"	3/8" Hose Barb	Steel
3JB3	3/8"	3/8" Push-Loc	Steel
3JS4	3/8"	1/2" Hose Barb	Steel
4FS3	1/2"	3/8" Hose Barb	Steel
4FS4	1/2"	1/2" Hose Barb	Steel
4FB4	1/2"	1/2" Push-Loc	Steel
4FS6	1/2"	3/4" Hose Barb	Steel

J-SERIES TRUFLATE AUTOMOTIVE INTERCHANGE (NIPPLE)



(Standard & Push-Loc Hose Barb)

PART NO.	BODY SIZE	BARB CONFIGURATION	BODY MATERIAL
J2S2	1/4"	1/4" Hose Barb	Steel
J2B2	1/4"	1/4" Push-Loc	Steel
J2S2.5	1/4"	5/16" Hose Barb	Steel
J2S3	1/4"	3/8" Hose Barb	Steel
J2B3	1/4"	3/8" Push-Loc	Steel
J3S2	3/8"	1/4" Hose Barb	Steel
J3S3	3/8"	3/8" Hose Barb	Steel
J3B3	3/8"	3/8" Push-Loc	Steel
J3S4	3/8"	1/2" Hose Barb	Steel
J4S3	1/2"	3/8" Hose Barb	Steel
J4S4	1/2"	1/2" Hose Barb	Steel
J4B4	1/2"	1/2" Push-Loc	Steel
J4S6	1/2"	3/4" Hose Barb	Steel

J-SERIES TRUFLATE AUTOMOTIVE INTERCHANGE (MANUAL COUPLER)



(Reusable Barb)

PART NO.	BODY SIZE	BARB CONFIGURATION	BODY MATERIAL
2JE2-B	1/4"	1/4" ID X 3/8" OD	Brass
2JH2-B	1/4"	1/4" ID X 5/8" OD	Brass
2JK3-B	1/4"	3/8" ID X 1 1/16" OD	Brass
2JL3-B	1/4"	3/8" ID X 3/4" OD	Brass

J-SERIES TRUFLATE AUTOMOTIVE INTERCHANGE (NIPPLE)



(Reusable Barb)

PART NO.	BODY SIZE	BARB CONFIGURATION	BODY MATERIAL
J2E2	1/4"	1/4" ID X 3/8" OD	Steel
J2H2	1/4"	1/4" ID X 5/8" OD	Steel
J2K3	1/4"	3/8" ID X 1 1/16" OD	Steel
J2L3	1/4"	3/8" ID X 3/4" OD	Steel

CJ-Series European High-Flow Interchange

- CJ-Series European Interchange couplings will provide up to 50% more air flow than standard pneumatic couplings
- All couplers have a high concentration of locking balls to reduce incidents of brinneling during operation
- CJ-Series 1/4" nipples are available in standard or 'LG' locking-groove variations to maximise international interchangeability
- Couplers have a sleeve-guard 'Lip' to reduce the risk of accidental disconnection while in service
- Pneumatically energised seal moulds itself to the nipples to maximise sealing performance at all pressures



PERFORMANCE SPECIFICATIONS	OPERATING BAR (psi)	MIN. BURST BAR (psi)	FLOW ΔP=0.4 BAR (6.9 BAR INLET)	LOCKING MECHANISM
1/4"	17 (250)	145 (2,100)	70 CFM	6 Balls
3/8"	17 (250)	141 (2,050)	136 CFM	6 Balls

INTERCHANGE GUIDE	COILHOSE MEGAFLOW	AMFLO	RECTUS	CEJN
1/4"	Megaflow™	Hi-Flo™	25KA/26KA/27KA	Cejn 320
3/8"	-	-	25K	Cejn 410

INTERCHANGE GUIDE	COILHOSE MEGAFLOW	AMFLO	RECTUS	CEJN
1/4"	Megaflow™	Hi-Flo™	25KA/26KA	Cejn 320
1/4" (LG)	-	Hi-Flo™	25KA/26KA/25KS	Cejn 320
3/8"	-	-	27KA	Cejn 410

CJ-SERIES CEJN 320/410 INTERCHANGE (AUTOMATIC COUPLER)



(Female Thread)

PART NO.	BODY SIZE	THREAD SIZE	BODY MATERIAL
2CJF2-B	1/4"	1/4"-18 NPTF	Brass
F-2CJF2-S	1/4"	1/4"-18 NPTF	303 Stainless Steel
2CJBF2-B	1/4"	G1/4" BSPP	Brass
F-2CJBF2-S	1/4"	G1/4" BSPP	303 Stainless Steel
2CJF3-B	1/4"	3/8"-18 NPTF	Brass
2CJBF3-B	1/4"	G3/8" BSPP	Brass
3CJF3-B	3/8"	3/8"-18 NPTF	Brass
3CJBF3-B	3/8"	G3/8" BSPP	Brass
3CJF4-B	3/8"	1/2"-14 NPTF	Brass
3CJBF4-B	3/8"	G1/2" BSPP	Brass



(Female Thread)

CJ-SERIES CEJN 320/410 INTERCHANGE (NIPPLE)

PART NO.	BODY SIZE	THREAD SIZE	BODY MATERIAL
CJ2F2-LG	1/4"	1/4"-18 NPTF	Steel
CJ2F2-B	1/4"	1/4"-18 NPTF	Brass
CJ2F2-S	1/4"	1/4"-18 NPTF	303 Stainless Steel
CJ2BF2-LG	1/4"	G1/4" BSPP	Steel
CJ2BF2-B	1/4"	G1/4" BSPP	Brass
CJ2BF2-S	1/4"	G1/4" BSPP	303 Stainless Steel
CJ2F3-LG	1/4"	3/8"-18 NPTF	Steel
CJ2F3-B	1/4"	3/8"-18 NPTF	Brass
CJ2BF3-LG	1/4"	G3/8" BSPP	Steel
CJ2BF3-B	1/4"	G3/8" BSPP	Brass
CJ2BF3-S	1/4"	G3/8" BSPP	303 Stainless Steel
CJ3F3	3/8"	3/8"-18 NPTF	Steel
CJ3BF3	3/8"	G3/8" BSPP	Steel
CJ3F4	3/8"	1/2"-14 NPTF	Steel
CJ3BF4	3/8"	G1/2" BSPP	Steel

CJ-SERIES CEJN 320/410 INTERCHANGE (AUTOMATIC COUPLER)



(Male Thread)

PART NO.	BODY SIZE	THREAD SIZE	BODY MATERIAL
2CJM2-B	1/4"	1/4"-18 NPTF	Brass
F-2CJM2-S	1/4"	1/4"-18 NPTF	303 Stainless Steel
2CJBM2-B	1/4"	R1/4" BSPT	Brass
F-2CJGM2-S	1/4"	G3/8" BSPT	303 Stainless Steel
2CJM3-B	1/4"	3/8"-18 NPTF	Brass
2CJBM3-B	1/4"	R3/8" BSPT	Brass
3CJM3-B	3/8"	3/8"-18 NPTF	Brass
3CJBM3-B	3/8"	R3/8" BSPT	Brass
3CJM4-B	3/8"	1/2"-14 NPTF	Brass
3CJBM4-B	3/8"	R1/2" BSPT	Brass

CJ-SERIES CEJN 320/410 INTERCHANGE (NIPPLE)



(Male Thread)

PART NO.	BODY SIZE	THREAD SIZE	BODY MATERIAL
CJ2M2-LG	1/4"	1/4"-18 NPT	Steel
CJ2M2-B	1/4"	1/4"-18 NPT	Brass
CJ2BM2-LG	1/4"	R1/4" BSP	Steel
CJ2BM2-B	1/4"	R1/4" BSP	Brass
CJ2BM2-S	1/4"	R1/4" BSP	303 Stainless Steel
CJ2M3-LG	1/4"	3/8"-18 NPT	Steel
CJ2M3-B	1/4"	3/8"-18 NPT	Brass
CJ2BM3-LG	1/4"	R3/8" BSP	Steel
CJ2BM3-B	1/4"	R3/8" BSP	Brass
CJ2BM3-S	1/4"	R3/8" BSP	303 Stainless Steel
CJ3M3	3/8"	3/8"-18 NPT	Steel
CJ3BM3	3/8"	R3/8" BSP	Steel
CJ3M4	3/8"	1/2"-14 NPT	Steel
CJ3BM4	3/8"	R1/2" BSP	Steel

Quick Release Couplings



(Standard Hose Barb)

CJ-SERIES CEJN 320/410 INTERCHANGE (AUTOMATIC COUPLER)

PART NO.	BODY SIZE	BARB CONFIGURATION	BODY MATERIAL
2CJS2-B	1/4"	1/4" Hose Barb	Brass
F-2CJS2-S	1/4"	1/4" Hose Barb	303 Stainless Steel
2CJS2.5-B	1/4"	5/16" Hose Barb	Brass
2CJS3-B	1/4"	5/16" Hose Barb	Brass
3CJS3-B	3/8"	3/8" Hose Barb	Brass
3CJS4-B	3/8"	1/2" Hose Barb	Brass

CJ-SERIES CEJN 320/410 INTERCHANGE (NIPPLE)



(Standard and Push-Loc Hose Barb)

PART NO.	BODY SIZE	BARB CONFIGURATION	BODY MATERIAL
CJ2S2	1/4"	1/4" Hose Barb	Steel
CJ2S2-B	1/4"	1/4" Hose Barb	Brass
CJ2S2-S	1/4"	1/4" Hose Barb	303 Stainless Steel
CJ2S2.5	1/4"	5/16" Hose Barb	Steel
CJ2S2.5-B	1/4"	5/16" Hose Barb	Brass
CJ2B2-LG	1/4"	1/4" Push-Loc	Steel
CJ2S3	1/4"	3/8" Hose Barb	Steel
CJ2S3-B	1/4"	3/8" Hose Barb	Brass
CJ2S3-S	1/4"	3/8" Hose Barb	303 Stainless Steel
CJ2B3-LG	1/4"	3/8" Push-Loc	Steel
CJ3S3	3/8"	3/8" Hose Barb	Steel
CJ3S4	3/8"	1/2" Hose Barb	Steel

IMPORTANT

Dixon carries two styles of European interchange nipples, Standard (No Suffix) and Locking-Groove (-LG Suffix). Both styles will fit in standard European interchange couplers but the Locking-Groove nipples will also fit into the Rectus '25KS' couplers.



Locking-Groove Style (-LG)



Standard Style

N Series Bowes/MacDonald Interchange

- Dual-guide sleeve tabs will ensure smooth collar action during connection and disconnection
- Convenient 'Push-Twist and Click' connection provides a positive locking condition while connected
- Pneumatically energised seal provides an airtight seal at all working pressures
- Optional safety-lock ring protects against accidental disconnection while coupling is in operation
- Highly versatile selection of end connections and body materials, as well as an available valved coupler option



PERFORMANCE SPECIFICATIONS	OPERATING BAR (psi)	BURST BAR (psi)	FLOW ΔP=0.4 BAR (6.9 BAR INLET)	LOCKING MECHANISM
3/8"	21 (300)	207 (3,000)	84 CFM	Latch Tabs
1/2"	21 (300)	207 (3,000)	250 CFM	Latch Tabs
1 1/4"	21 (300)	103 (1,500)	700 CFM	Latch Tabs

INTERCHANGE STANDARDS	US MILITARY	US GOVERNMENT	INTERNATIONAL STANDARDS	ANSI/NFPA
1/2"	MIL-C-3486	A-A-50431A	-	-

'N' SERIES INTERCHANGE	BOWES	NATIONAL	MACDONALD	DIXON
3/8"	-	-	-	-
1/2"	51000 Series	Series 'B'	Quick-Action	Dixlock
1 1/4"	51000 Series	-	-	-



(Male Thread)

N-SERIES (MINI-BOWES) INTERCHANGE (COUPLER)			
PART NO.	BODY SIZE	THREAD SIZE	BODY MATERIAL
3NM4	3/8"	1/2"-14 NPTF	steel
3NBM4	3/8"	R1/2" BSPT	steel



(Male Thread)

N-SERIES (MINI-BOWES) INTERCHANGE (NIPPLE)			
PART NO.	BODY SIZE	THREAD SIZE	BODY MATERIAL
N3M4	3/8"	1/2"-14 NPTF	steel
N3BM4	3/8"	R1/2" BSPT	steel



(Collar Barb)

N-SERIES (MINI-BOWES) INTERCHANGE (COUPLER)			
PART NO.	BODY SIZE	BARB CONFIGURATION	BODY MATERIAL
3NCS4	3/8"	1/2" Collar Barb	steel

Quick Release Couplings



(Collar Barb)

N-SERIES (MINI-BOWES) INTERCHANGE (NIPPLE)			
PART NO.	BODY SIZE	BARB CONFIGURATION	BODY MATERIAL
N3CS4	3/8"	1/2" Collar Barb	steel



(Female Thread)

N-SERIES MACDONALD INTERCHANGE (UNVALVED COUPLER)			
PART NO.	BODY SIZE	THREAD SIZE	BODY MATERIAL
4NF3	1/2"	3/8"-18 NPTF	steel
4NF3-B	1/2"	3/8"-18 NPTF	brass
4NBF3	1/2"	G3/8" BSPP	steel
4NF4	1/2"	1/2"-14 NPTF	steel
4NF4-B	1/2"	1/2"-14 NPTF	brass
4NBF4	1/2"	G1/2" BSPP	steel
4NBF4-B	1/2"	G1/2" BSPP	brass
4NF6	1/2"	3/4"-14 NPTF	steel
4NF6-B	1/2"	3/4"-14 NPTF	brass
4NF6-S	1/2"	3/4"-14 NPTF	303 SS
4NBF6	1/2"	G3/4" BSPP	steel
4NBF6-B	1/2"	G3/4" BSPP	brass
4NF8	1/2"	1"-11 1/2 NPTF	steel
4NF8-B	1/2"	1"-11 1/2 NPTF	brass
4NBF8	1/2"	G1" BSPP	steel
4NBF8-B	1/2"	G1" BSPP	brass



(Female Thread)

N-SERIES MACDONALD INTERCHANGE (VALVED COUPLER)			
PART NO.	BODY SIZE	THREAD SIZE	BODY MATERIAL
4NF6-V	1/2"	3/4"-14 NPTF	steel
4NBF6-V	1/2"	G3/4" BSPP	steel



(Female Thread)

N-SERIES MACDONALD INTERCHANGE (NIPPLE)			
PART NO.	BODY SIZE	THREAD SIZE	BODY MATERIAL
N4F3	1/2"	3/8"-18 NPTF	steel
N4F3-B	1/2"	3/8"-18 NPTF	brass
N4BF3	1/2"	G3/8" BSPP	steel
N4F4	1/2"	1/2"-14 NPTF	steel
N4F4-B	1/2"	1/2"-14 NPTF	brass
N4BF4	1/2"	G1/2" BSPP	steel
N4BF4-B	1/2"	G1/2" BSPP	brass
N4F6	1/2"	3/4"-14 NPTF	steel
N4F6-B	1/2"	3/4"-14 NPTF	brass
N4F6-S	1/2"	3/4"-14 NPTF	303 SS
N4BF6	1/2"	G3/4" BSPP	steel
N4BF6-B	1/2"	G3/4" BSPP	brass
N4F8	1/2"	1"-11 1/2 NPTF	steel
N4F8-B	1/2"	1"-11 1/2 NPTF	brass
N4BF8	1/2"	G1" BSPP	steel
N4BF8-B	1/2"	G1" BSPP	brass



(Female Thread)

N-SERIES MACDONALD INTERCHANGE (SAFETY-LOCK NIPPLE)			
PART NO.	BODY SIZE	THREAD SIZE	BODY MATERIAL
N4F4-B-LS	1/2"	1/2"-14 NPTF	brass
N4F6-B-LS	1/2"	3/4"-14 NPTF	brass

N-SERIES MACDONALD INTERCHANGE (UNVALVED COUPLER)



(Male Thread)

PART NO.	BODY SIZE	THREAD SIZE	BODY MATERIAL
4NM3	1/2"	3/8"-18 NPTF	steel
4NM3-B	1/2"	3/8"-18 NPTF	brass
4NBM3	1/2"	R ^{3/8} " BSPT	steel
4NM4	1/2"	1/2"-14 NPTF	steel
4NM4-B	1/2"	1/2"-14 NPTF	brass
4NBM4	1/2"	R ^{1/2} " BSPT	steel
4NBM4-B	1/2"	R ^{1/2} " BSPT	brass
4NM6	1/2"	3/4"-14 NPTF	steel
4NM6-B	1/2"	3/4"-14 NPTF	brass
4NM6-S	1/2"	3/4"-14 NPTF	303 SS
4NBM6	1/2"	R ^{3/4} " BSPT	steel
4NBM6-B	1/2"	R ^{3/4} " BSPT	brass
4NM8	1/2"	1"-11 ^{1/2} NPTF	steel
4NM8-B	1/2"	1"-11 ^{1/2} NPTF	brass
4NBM8	1/2"	R1" BSPT	steel
4NBM8-B	1/2"	R1" BSPT	brass

N-SERIES MACDONALD INTERCHANGE (VALVED COUPLER)



(Male Thread)

PART NO.	BODY SIZE	THREAD SIZE	BODY MATERIAL
4NM6-V	1/2"	3/4"-14 NPTF	steel

N-SERIES MACDONALD INTERCHANGE (NIPPLE)



(Male Thread)

PART NO.	BODY SIZE	THREAD SIZE	BODY MATERIAL
N4M3	1/2"	3/8"-18 NPTF	steel
N4M3-B	1/2"	3/8"-18 NPTF	brass
N4BM3	1/2"	R ^{3/8} " BSPT	steel
N4M4	1/2"	1/2"-14 NPTF	steel
N4M4-B	1/2"	1/2"-14 NPTF	brass
N4BM4	1/2"	R ^{1/2} " BSPT	steel
N4BM4-B	1/2"	R ^{1/2} " BSPT	brass
N4M6	1/2"	3/4"-14 NPTF	steel
N4M6-B	1/2"	3/4"-14 NPTF	brass
N4M6-S	1/2"	3/4"-14 NPTF	303 SS
N4BM6	1/2"	R ^{3/4} " BSPT	steel
N4BM6-B	1/2"	R ^{3/4} " BSPT	brass
N4M8	1/2"	1"-11 ^{1/2} NPTF	steel
N4M8-B	1/2"	1"-11 ^{1/2} NPTF	brass
N4BM8	1/2"	R1" BSPT	steel
N4BM8-B	1/2"	R1" BSPT	brass

N-SERIES MACDONALD INTERCHANGE (SAFETY-LOCK NIPPLE)



(Male Thread)

PART NO.	BODY SIZE	THREAD SIZE	BODY MATERIAL
N4M4-LS	1/2"	1/2"-14 NPTF	steel
N4M4-B-LS	1/2"	1/2"-14 NPTF	brass
N4BM4-LS	1/2"	R ^{1/2} " BSPT	steel
N4M6-LS	1/2"	3/4"-14 NPTF	steel
N4M6-B-LS	1/2"	3/4"-14 NPTF	brass
N4M6-S-LS	1/2"	3/4"-14 NPTF	303 SS
N4BM6-LS	1/2"	R ^{3/4} " BSPT	steel

Quick Release Couplings



(Hose Barb - now accepts light duty ferrules)

N-SERIES MACDONALD INTERCHANGE (COUPLER)			
PART NO.	BODY SIZE	BARB CONFIGURATION	BODY MATERIAL
4NS3	1/2"	3/8" Hose Barb	steel
4NS3-B	1/2"	3/8" Hose Barb	brass
4NS4	1/2"	1/2" Hose Barb	steel
4NS4-B	1/2"	1/2" Hose Barb	brass
4NS6	1/2"	3/4" Hose Barb	steel
4NS6-B	1/2"	3/4" Hose Barb	brass
4NS6-S	1/2"	3/4" Hose Barb	303 SS
4NS8	1/2"	1" Hose Barb	steel
4NS8-B	1/2"	1" Hose Barb	brass



(Hose Barb with Staked Ferrule)

N-SERIES MACDONALD INTERCHANGE (COUPLER)			
PART NO.	BODY SIZE	HOSE (ID) OD RANGE	BODY MATERIAL
4NCS4-WF43	1/2"	(1/2") 27/32" to 1 1/32"	steel
4NCS4-B-WF43	1/2"	(1/2") 27/32" to 1 1/32"	brass
4NCS6-WF63	1/2"	(3/4") 15/32" to 1 1/32"	steel
4NCS6-B-WF63	1/2"	(3/4") 15/32" to 1 1/32"	brass
4NCS6-S-WFS63	1/2"	(3/4") 15/32" to 1 1/32"	303 SS



(Hose Barb - now accepts light duty ferrules)

N-SERIES MACDONALD INTERCHANGE (NIPPLE)			
PART NO.	BODY SIZE	BARB CONFIGURATION	BODY MATERIAL
N4S3	1/2"	3/8" Hose Barb	steel
N4S3-B	1/2"	3/8" Hose Barb	brass
N4S4	1/2"	1/2" Hose Barb	steel
N4S4-B	1/2"	1/2" Hose Barb	brass
N4S6	1/2"	3/4" Hose Barb	steel
N4S6-B	1/2"	3/4" Hose Barb	brass
N4S6-S	1/2"	3/4" Hose Barb	303 SS
N4S8	1/2"	1" Hose Barb	steel
N4S8-B	1/2"	1" Hose Barb	brass



(Hose Barb with Staked Ferrule)

N-SERIES MACDONALD INTERCHANGE (NIPPLE)			
PART NO.	BODY SIZE	HOSE (ID) OD RANGE	BODY MATERIAL
N4CS4-WF43	1/2"	(1/2") 27/32" to 1 1/32"	steel
N4CS4-B-WF43	1/2"	(1/2") 27/32" to 1 1/32"	brass
N4CS6-WF63	1/2"	(3/4") 15/32" to 1 1/32"	steel
N4CS6-B-WF63	1/2"	(3/4") 15/32" to 1 1/32"	brass
N4CS6-S-WFS63	1/2"	(3/4") 15/32" to 1 1/32"	303 SS



(Hose Barb - now accepts light duty ferrules)

N-SERIES MACDONALD INTERCHANGE (SAFETY-LOCK NIPPLE)			
PART NO.	BODY SIZE	BARB CONFIGURATION	BODY MATERIAL
N4S4-LS	1/2"	1/2" Hose Barb	steel
N4S4-B-LS	1/2"	1/2" Hose Barb	brass
N4S6-LS	1/2"	3/4" Hose Barb	steel
N4S6-B-LS	1/2"	3/4" Hose Barb	brass
N4S6-S-LS	1/2"	3/4" Hose Barb	303 SS



(Hose Barb with Staked Ferrule)

N-SERIES MACDONALD INTERCHANGE (SAFETY-LOCK NIPPLE)			
PART NO.	BODY SIZE	HOSE (ID) OD RANGE	BODY MATERIAL
N4CS4-LS-WF43	1/2"	(1/2") 27/32" to 11/32"	steel
N4CS4-B-LS-WF43	1/2"	(1/2") 27/32" to 11/32"	brass
N4CS6-LS-WF63	1/2"	(3/4") 15/32" to 11/32"	steel
N4CS6-B-LS-WF63	1/2"	(3/4") 15/32" to 11/32"	brass
N4CS6-S-LS-WFS63	1/2"	(3/4") 15/32" to 11/32"	303 SS



(Female Thread)

N-SERIES (MEGA-BOWES) INTERCHANGE (COUPLER)			
PART NO.	BODY SIZE	THREAD SIZE	BODY MATERIAL
10NF8-B	1 1/4"	1"-1 1/2" NPTF	brass
10NF10-B	1 1/4"	1 1/4"-1 1/2" NPTF	brass



(Female Thread)

N-SERIES (MEGA-BOWES) INTERCHANGE (NIPPLE)			
PART NO.	BODY SIZE	THREAD SIZE	BODY MATERIAL
N10F8-B	1 1/4"	1"-1 1/2" NPTF	brass
N10F10-B	1 1/4"	1 1/4"-1 1/2" NPTF	brass



(Male Thread)

N-SERIES (MEGA-BOWES) INTERCHANGE (COUPLER)			
PART NO.	BODY SIZE	THREAD SIZE	BODY MATERIAL
10NM8-B	1 1/4"	1"-1 1/2" NPTF	brass
10NM10-B	1 1/4"	1 1/4"-1 1/2" NPTF	brass



(Male Thread)

N-SERIES (MEGA-BOWES) INTERCHANGE (NIPPLE)			
PART NO.	BODY SIZE	THREAD SIZE	BODY MATERIAL
N10M8-B	1 1/4"	1"-1 1/2" NPTF	brass
N10M10-B	1 1/4"	1 1/4"-1 1/2" NPTF	brass

A Safety Check Valve, also known as an Excessive Flow Sensor should be installed at the source of supply to protect the operator in case of coupling failure or hose rupture.



Quick Release Couplings



N-SERIES MACDONALD INTERCHANGE (GENDER-CHANGE UNION)

PART NO.	BODY SIZE	PART DESCRIPTION	BODY MATERIAL
4N4N	1/2"	Coupler to Coupler	steel



N-SERIES MACDONALD INTERCHANGE (Y-COUPLERS)

PART NO.	BODY SIZE	INLET/OUTLET CONFIGURATION	BODY MATERIAL
N4Y4N-4N	1/2"	Nipple to Couplers	steel



N-SERIES MACDONALD INTERCHANGE (Y-NIPPLES)

PART NO.	BODY SIZE	INLET/OUTLET CONFIGURATION	BODY MATERIAL
4NYN4-N4	1/2"	Nipple to Couplers	steel



N-SERIES MACDONALD INTERCHANGE (PROTECTIVE NIPPLE CAP)

PART NO.	BODY SIZE	PART DESCRIPTION	BODY MATERIAL
N4DC	1/2"	Nipple Dust Cap	steel
N4DC-B	1/2"	Nipple Dust Cap	brass



N-SERIES MACDONALD INTERCHANGE (REPLACEMENT PARTS)

PART NO.	BODY SIZE	PART DESCRIPTION	PART MATERIAL
3N-SKIT	3/8"	Sealing Gasket	Nitrile
4N-SKIT	1/2"	Sealing Gasket	Nitrile
10N-SKIT	1 1/4"	Sealing Gasket	Nitrile

P-Series Thor Interchange

- Interlocking finger connection method with single or dual locking sleeves for maximum security
- Convenient 'Push-Twist and Click' connection provides a positive locking condition while connected
- Corrosion resistant steel construction and a variety of other materials available to provide additional corrosion resistance
- Optional safety-lock clip protects against accidental disconnection while coupling is in operation
- Highly versatile selection of end connections includes Female NPTF, Male NPTF and Hose barb



PERFORMANCE SPECIFICATIONS	OPERATING BAR (psi)	BURST BAR (psi)	FLOW ΔP=0.4 BAR (6.9 BAR INLET)	LOCKING MECHANISM
1/2"	21 (300)	331 (4,800)	250 CFM	Latch Fingers

'P' SERIES INTERCHANGE	THOR	NATIONAL	DIXON	-
1/2"	PHC	Series 'A'	Dual-Lock	-



(Female Thread)

P-SERIES THOR INTERCHANGE (COUPLER)

PART NO.	BODY SIZE	THREAD SIZE	BODY MATERIAL
4PF4	1/2"	1/2"-14 NPTF	steel
4PF6	1/2"	3/4"-14 NPTF	steel
4PF6-B	1/2"	3/4"-14 NPTF	brass
4PF6-S	1/2"	3/4"-14 NPTF	303 SS



(Female Thread)

P-SERIES THOR INTERCHANGE (FLANGED-SLEEVE COUPLER)

PART NO.	BODY SIZE	THREAD SIZE	BODY MATERIAL
4PF4-FS	1/2"	1/2"-14 NPTF	steel
4PF6-FS	1/2"	3/4"-14 NPTF	steel



(Female Thread)

P-SERIES THOR INTERCHANGE (NIPPLE)

PART NO.	BODY SIZE	THREAD SIZE	BODY MATERIAL
P4F3	1/2"	3/8"-18 NPTF	steel
P4F4	1/2"	1/2"-14 NPTF	steel
P4F4-B	1/2"	1/2"-14 NPTF	brass
P4F6	1/2"	3/4"-14 NPTF	steel
P4F6-B	1/2"	3/4"-14 NPTF	brass
P4F6-S	1/2"	3/4"-14 NPTF	303 SS
P4F8	1/2"	1"-11 1/2 NPTF	steel
P4F8-B	1/2"	1"-11 1/2 NPTF	brass

Quick Release Couplings



(Male Thread)

P-SERIES THOR INTERCHANGE (COUPLER)

PART NO.	BODY SIZE	THREAD SIZE	BODY MATERIAL
4PM3	1/2"	3/8"-18 NPTF	steel
4PM4	1/2"	1/2"-14 NPTF	steel
4PM6	1/2"	3/4"-14 NPTF	steel
4PM6-S	1/2"	3/4"-14 NPTF	303 SS



(Male Thread)

P-SERIES THOR INTERCHANGE (FLANGED-SLEEVE COUPLER)

PART NO.	BODY SIZE	THREAD SIZE	PART MATERIAL
4PM3-FS	1/2"	3/8"-18 NPTF	steel
4PM4-FS	1/2"	1/2"-14 NPTF	steel
4PM6-FS	1/2"	3/4"-14 NPTF	steel



(Male Thread)

P-SERIES THOR INTERCHANGE (NIPPLE)

PART NO.	BODY SIZE	THREAD SIZE	BODY MATERIAL
P4M3	1/2"	3/8"-18 NPTF	steel
P4M4	1/2"	1/2"-14 NPTF	steel
P4M4-B	1/2"	1/2"-14 NPTF	brass
P4M6	1/2"	3/4"-14 NPTF	steel
P4M6-B	1/2"	3/4"-14 NPTF	brass
P4M6-S	1/2"	3/4"-14 NPTF	303 SS
P4M8	1/2"	1"-11 1/2 NPTF	steel
P4M8-B	1/2"	1"-11 1/2 NPTF	brass



(Hose Barb - now accepts light duty ferrules)

P-SERIES THOR INTERCHANGE (COUPLER)

PART NO.	BODY SIZE	BARB CONFIGURATION	BODY MATERIAL
4PS3	1/2"	3/8" Hose Barb	steel
4PS4	1/2"	1/2" Hose Barb	steel
4PS4-B	1/2"	1/2" Hose Barb	brass
4PS6	1/2"	3/4" Hose Barb	steel
4PS6-B	1/2"	3/4" Hose Barb	brass
4PS6-S	1/2"	3/4" Hose Barb	303 SS
4PS8	1/2"	1" Hose Barb	steel
4PS8-B	1/2"	1" Hose Barb	brass



(Hose Barb - now accepts light duty ferrules)

P-SERIES THOR INTERCHANGE (FLANGED-SLEEVE COUPLER)

PART NO.	BODY SIZE	BARB CONFIGURATION	BODY MATERIAL
4PS3-FS	1/2"	3/8" Hose Barb	steel
4PS4-FS	1/2"	1/2" Hose Barb	steel
4PS6-FS	1/2"	3/4" Hose Barb	steel
4PS8-FS	1/2"	1" Hose Barb	steel



(Hose Barb with Staked Ferrule)

P-SERIES THOR INTERCHANGE (COUPLER)

PART NO.	BODY SIZE	HOSE (ID) OD RANGE	BODY MATERIAL
4PCS4-WF43	1/2"	(1/2") 27/32" to 11/32"	steel
4PCS4-B-WF43	1/2"	(1/2") 27/32" to 11/32"	brass
4PCS6-WF63	1/2"	(3/4") 15/32" to 11/32"	steel
4PCS6-B-WF63	1/2"	(3/4") 15/32" to 11/32"	brass



(Hose Barb with Staked Ferrule)

P-SERIES THOR INTERCHANGE (FLANGED-SLEEVE COUPLER)

PART NO.	BODY SIZE	HOSE (ID) OD RANGE	BODY MATERIAL
4PCS4-FS-WF43	1/2"	(1/2") 27/32" to 11/32"	steel
4PCS6-FS-WF63	1/2"	(3/4") 15/32" to 11/32"	steel

P-SERIES THOR INTERCHANGE (REPLACEMENT PARTS)



PART NO.	BODY SIZE	PART DESCRIPTION	BODY MATERIAL
4P-SKIT	1/2"	Seal Gasket	Nitrile
4P-CLIP	1/2"	Sleeve-Lock Clip	steel
4P-CLIPS	1/2"	Spring Clip	steel



J

Steam Couplings - Boss™

Boss Coupling System.....	338
Boss Ground Joint Seal Couplings.....	339
Boss Stems.....	340
Boss Wing Nuts	340
Boss Spud Adapters	341
Boss Hose Menders	342
Boss Adapters & Stems	342-343
Boss Clamps.....	344-345
Steam Hose Fittings BS EN 14423:2004.....	346

**FOR A FULL RANGE OF STEAM HOSES
TO COMPLEMENT THESE FITTINGS SEE SECTION F**

J



Boss™ Coupling System

Features: The spud part of the coupling serves as one half of the connection and is usually fixed to the equipment. The stem part that is clamped to the hose is the other half. The two halves are connected or disconnected by rotating the wing nut onto the spud. When connected they achieve a mechanical, as well as, a pressure seal.

Services: Boss couplings are all-purpose hose couplings, universally recommended for steam hose connections. They are also widely used for air, water, fluid petroleum, chemicals and liquid petroleum gas up to 1" ID. Boss couplings can be applied to many types of rubber, synthetic, plastic, metallic or semi-metallic hose. Consult the factory for specific media capabilities.

Purpose: Boss couplings supply a convenient threaded fitting to connect two lengths of hose, or a single length to a male or female threaded (NPT) outlet.

Material:

- Stem: ¼" - 1" plated steel, 1¼" - 4" plated iron, 6" tubular steel
- Spud: ¼" - 1" plated steel, 1¼" - 6" plated iron
- Wing nut: ¼" - 1" plated steel, 1¼" - 6" plated iron

Seal Types:

- Ground joint: copper or polymer seats
- Washer: Klingersil® C-4401

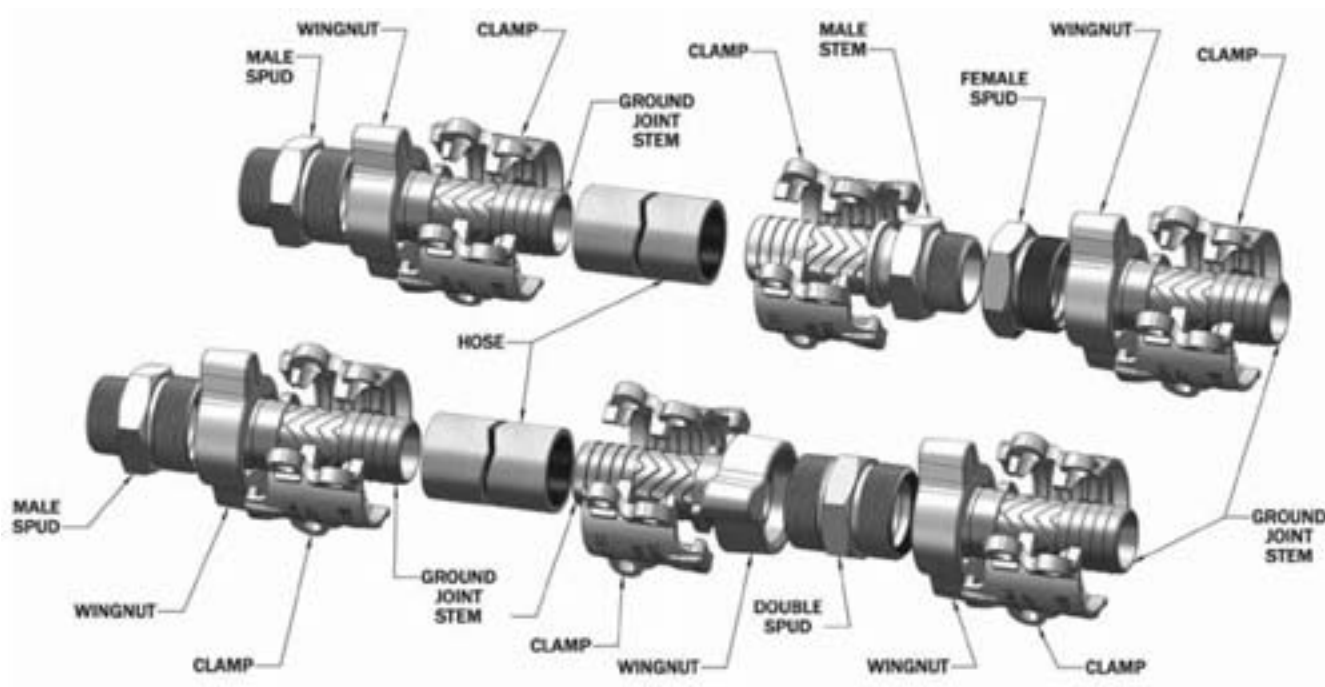

SAFETY ALERT

Worn-out hose couplings can be dangerous. They should be checked regularly and replaced when necessary. Each coupling user should review applications and add safety devices where indicated.

Boss™ Ground Joint Seal Couplings

Sizes: 1/4" to 6".

Materials: Plated Steel and/or Malleable Iron, Stainless Steel and Brass.

Pressure: Maximum working pressure 600 psi (using Boss™ clamps at correct torque setting).

Details: Boss™ Non-Metallic Polymer Seat (U.S. Patent No. 5, 577, 777) is not subject to corrosion and offers resistance to chemicals and steam found in manufacturing facilities. A precision machined recess holds the seat firmly in place, allowing it to absorb harsh punishment. Recommended for steam service up to 232°C (450°F); easy to seal; works with existing Boss™ Ground Joint Stems.

Use only with genuine Boss™ Clamps made in U.S.A.



BOSS™ COMPLETE COUPLING			
PART NO.	SIZE	THREAD	MATERIAL
GF1*	1/4"	BSP PI./NPT	Plated Steel/Malleable Iron
GF3*	3/8"	BSP PI./NPT	Plated Steel/Malleable Iron
GF6	1/2"	BSP PI./NPT	Plated Steel/Malleable Iron
GF26	3/4"	BSP PI./NPT	Plated Steel/Malleable Iron
GF36	1"	BSP PI./NPT	Plated Steel/Malleable Iron
GF51	1 1/4"	BSP PI./NPT	Plated Steel/Malleable Iron
GF61	1 1/2"	BSP PI./NPT	Plated Steel/Malleable Iron
GF81**	2"	BSP PI./NPT	Plated Steel/Malleable Iron
GF96	2 1/2"	BSP PI./NPT	Plated Steel/Malleable Iron
GF111	3"	BSP PI./NPT	Plated Steel/Malleable Iron
GF141	4"	BSP PI./NPT	Plated Steel/Malleable Iron
GF201*	6"	BSP PI./NPT	Plated Steel/Malleable Iron
RGF26	3/4"	BSP PI./NPT	316 Stainless Steel
RGF36	1"	BSP PI./NPT	316 Stainless Steel
RGF51	1 1/4"	BSP PI./NPT	316 Stainless Steel
RGF61	1 1/2"	BSP PI./NPT	316 Stainless Steel
RGF81	2"	BSP PI./NPT	316 Stainless Steel
BGF26	3/4"	BSP PI./NPT	Brass
BGF36	1"	BSP PI./NPT	Brass
BGF51	1 1/4"	BSP PI./NPT	Brass
BGF61	1 1/2"	BSP PI./NPT	Brass
BGF81	2"	BSP PI./NPT	Brass

* GF1, GF3, GF201, are supplied with Copper Seat Spuds.

** GF81 are not to be used with #250 or #306 Boss™ Clamps.

Boss™ Stems and Wing Nuts



BOSS™ STEM		
PART NO.	SIZE	MATERIAL
GBA	1/4"	Plated Steel
GCA	3/8"	Plated Steel
GB1	1/2"	Plated Steel
GB6	3/4"	Plated Steel
GB11	1"	Plated Steel
GB16	1 1/4"	Plated Steel/Malleable Iron
GB21	1 1/2"	Plated Steel/Malleable Iron
GB26**	2"	Plated Steel/Malleable Iron
GB31	2 1/2"	Plated Steel/Malleable Iron
GB36	3"	Plated Steel/Malleable Iron
GB46	4"	Plated Steel/Malleable Iron
GB66	6"	Plated Steel/Malleable Iron
RGB6	3/4"	316 Stainless Steel
RGB11	1"	316 Stainless Steel
RGB16	1 1/4"	316 Stainless Steel
RGB21	1 1/2"	316 Stainless Steel
RGB26	2"	316 Stainless Steel
BGB6	3/4"	Brass
BGB11	1"	Brass
BGB16	1 1/4"	Brass
BGB21	1 1/2"	Brass
BGB26	2"	Brass

** GB26 are not to be used with #250 or #306 Boss™ Clamps.

J



BOSS™ WING NUT THREAD		
PART NO.	SIZE	MATERIAL
BA2	1/4"	Malleable Iron
CB	3/8"	Malleable Iron
B2	1/2"	Malleable Iron
B12	3/4"	Malleable Iron
B12	1"	Malleable Iron
B17	1 1/4"	Malleable Iron
B17	1 1/2"	Malleable Iron
B27	2"	Malleable Iron
B32	2 1/2"	Malleable Iron
B37	3"	Malleable Iron
B47	4"	Malleable Iron
B67	6"	Malleable Iron
RB12	3/4"	316 Stainless Steel
RB12	1"	316 Stainless Steel
RB17	1 1/4"	316 Stainless Steel
RB17	1 1/2"	316 Stainless Steel
RB27	2"	316 Stainless Steel
BB12	3/4"	Brass
BB12	1"	Brass
BB17	1 1/4"	Brass
BB17	1 1/2"	Brass
BB27	2"	Brass

Boss™ Spud Adapters



BOSS™ FEMALE SPUD			
PART NO.	SIZE	THREAD	MATERIAL
GBC	1/4"	BSP PI./NPT	Plated Steel
GCC	3/8"	BSP PI./NPT	Plated Steel
GB3	1/2"	BSP PI./NPTI	Plated Steel
GB8	3/4"	BSP PI./NPT	Plated Steel
GB13	1"	BSP PI./NPT	Plated Steel
GB18	1 1/4"	BSP PI./NPT	Plated Steel/Malleable Iron
GB23	1 1/2"	BSP PI./NPT	Plated Steel/Malleable Iron
GB28	2"	BSP PI./NPT	Plated Steel/Malleable Iron
GB33	2 1/2"	BSP PI./NPT	Plated Steel/Malleable Iron
GB38	3"	BSP PI./NPT	Plated Steel/Malleable Iron
GB48	4"	BSP PI./NPT	Plated Steel/Malleable Iron
GB68	6"	BSP PI./NPT	Plated Steel/Malleable Iron
RGB8	3/4"	BSP PI./NPT	316 Stainless
RGB13	1"	BSP PI./NPT	316 Stainless
RGB18	1 1/4"	BSP PI./NPT	316 Stainless
RGB23	1 1/2"	BSP PI./NPT	316 Stainless
RGB28	2"	BSP PI./NPT	316 Stainless
BGB8	3/4"	BSP PI./NPT	Brass
BGB13	1"	BSP PI./NPT	Brass
BGB18	1 1/4"	BSP PI./NPT	Brass
BGB23	1 1/2"	BSP PI./NPT	Brass
BGB28	2"	BSP PI./NPT	Brass



BOSS™ MALE SPUD X WING NUT THREAD			
PART NO.	SIZE	THREAD	MATERIAL
GMC	3/8"	BSPT/NPT	Plated Steel/Malleable Iron
GM3	1/2"	BSPT/NPT	Plated Steel/Malleable Iron
GM8	3/4"	BSPT/NPT	Plated Steel/Malleable Iron
GM13	1"	BSPT/NPT	Plated Steel/Malleable Iron
GM18	1 1/4"	BSPT/NPT	Plated Steel/Malleable Iron
GM23	1 1/2"	BSPT/NPT	Plated Steel/Malleable Iron
GM28	2"	BSPT/NPT	Plated Steel/Malleable Iron
GM33	2 1/2"	BSPT/NPT	Plated Steel/Malleable Iron
GM38	3"	BSPT/NPT	Plated Steel/Malleable Iron



BOSS™ DOUBLE SPUD X WING NUT THREAD		
PART NO.	SIZE	MATERIAL
GDB3	1/2"	Plated Steel/Malleable Iron
GDB13	3/4"	Plated Steel/Malleable Iron
GDB13	1"	Plated Steel/Malleable Iron
GDB23	1 1/4"	Plated Steel/Malleable Iron
GDB23	1 1/2"	Plated Steel/Malleable Iron
GDB28	2"	Plated Steel/Malleable Iron
GDB33	2 1/2"	Plated Steel/Malleable Iron
GDB38	3"	Plated Steel/Malleable Iron

J

Boss™ Adapters & Hose Menders

BOSS™ MALE STEM

PART NO.	SIZE	THREAD	MATERIAL
MS4X2	1/4" x 1/8"	NPT	Steel
MSA	1/4" x 1/4"	BSPT/NPT	Steel
MSB	1/4" x 3/8"	BSPT/NPT	Steel
MS6X4	3/8" x 1/4"	NPT	Steel
MSC	3/8" x 3/8"	BSPT/NPT	Steel
MS6X8	3/8" x 1/2"	NPT	Steel
MS8X4	1/2" x 1/4"	NPT	Steel
MS8X6	1/2" x 3/8"	NPT	Steel
MS1	1/2" x 1/2"	BSPT/NPT	Steel
MS8X12	1/2" x 3/4"	NPT	Steel
MS12X8	3/4" x 1/2"	NPT	Steel
MS6	3/4" x 3/4"	BSPT/NPT	Steel
MS12X16	3/4" x 1"	NPT	Steel
MS16X12	1" x 3/4"	NPT	Steel
MS11	1"	BSPT/NPT	Steel
MS16	1 1/4"	BSPT/NPT	Malleable Iron
MS21	1 1/2"	BSPT/NPT	Malleable Iron
MS26	2"	BSPT/NPT	Malleable Iron
MS31	2 1/2"	BSPT/NPT	Malleable Iron
MS36	3"	BSPT/NPT	Malleable Iron
MS46	4"	BSPT/NPT	Malleable Iron
RMS1	1/2"	BSPT/NPT	316 Stainless Steel
RMS6	3/4"	BSPT/NPT	316 Stainless Steel
RMS11	1"	BSPT/NPT	316 Stainless Steel
RMS16	1 1/4"	BSPT/NPT	316 Stainless Steel
RMS21	1 1/2"	BSPT/NPT	316 Stainless Steel
RMS26	2"	BSPT/NPT	316 Stainless Steel
RMS31	2 1/2"	BSPT/NPT	316 Stainless Steel
RMS36	3"	BSPT/NPT	316 Stainless Steel
BMS6	3/4"	BSPT/NPT	Brass
BMS11	1"	BSPT/NPT	Brass
BMS16	1 1/4"	BSPT/NPT	Brass
BMS21	1 1/2"	BSPT/NPT	Brass
BMS26	2"	BSPT/NPT	Brass
BMS36	3"	BSPT/NPT	Brass



J

BOSS™ HOSE MENDER

PART NO.	SIZE	MATERIAL
M1	1/2"	Steel
M6	3/4"	Malleable Iron
M11	1"	Malleable Iron
M16	1 1/4"	Malleable Iron
M21	1 1/2"	Malleable Iron
M26	2"	Malleable Iron
M31	2 1/2"	Malleable Iron
M36	3"	Malleable Iron
M46	4"	Malleable Iron
M66	6"	Steel





BOSS™ MALE NPT ADAPTER

PART NO.	SIZE	THREAD
GMAS6	3/4"	NPT
GMAS11	1"	NPT
GMAS21	1 1/2"	NPT
GMAS26*	2"	NPT
B27-3		Wing nut for GMAS26.

* GMAS26 requires a Special Wing Nut, part number B27-3

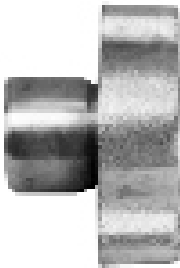

BOSS™ FEMALE NPT ADAPTER

PART NO.	SIZE	THREAD
GFAS6	3/4"	NPT
GFAS11	1"	NPT

Note: Wing nut is permanently attached on 1" size



BOSS™ WING NUT CAPS

PART NO.	SIZE
B12SC	3/4" and 1"
B17SC	1 1/4" and 1 1/2"
B27SC	2"
B37SC	3"

Note: Supplied with 12" chain and washer.

Boss Wing Nut Caps are not intended for pressure applications

J



male NPT end



male NPT end

LP-BOSS MALE STEMS

PLATED STEEL PART NO.	316 STAINLESS STEEL PART NO.	SCHD.80 PLATED STEEL PART NO.	UNPLATED STEEL PART NO.	SIZE
LP16	-	LP16 - 80	-	1 1/4"
LP21	-	LP21 - 80	-	1 1/2"
LP26	-	LP26 - 80	LPB26	2"
LP31	-	-	-	2 1/2"
LP36	RLP36	-	LPB36	3"
LP46	RLP46	-	-	4"
LP66	-	-	-	6"

Boss™ Clamps

Sizes: 1/4" to 3".

Materials: Plated Malleable Iron, Investment Cast Carbon Steel, Stainless Steel and Brass.

Pressure: Refer to Dixon pressure recommendations chart.

Details: The stated torque values apply to Plated Malleable Iron and Stainless Steel Clamps only and is expressed in ft.lbs. Torque values for Clamps are based on "Dry Bolts". The use of lubricants on bolts will adversely effect clamp performance.

The bolt used in BOSS™ interlocking clamps are Non-Standard. They vary from standard bolts in their length, diameter, overall thread length, material and material hardness. These bolts can be re-torqued, but it is not recommended that they be re-used, as they are designed for a single bend only. Dixon recommends using only factory supplied replacement bolts. The use of non Dixon bolts may result in serious injury or damage.



J

BOSS™ CLAMP - 2 BOLT TYPE					
PART NO.	HOSE I.D. SIZE	HOSE O.D. (MM)		MATERIAL	TORQUE
		FROM:	TO:		
BD*	1/4"	14.0	17.0	Plated Malleable Iron	6
CD*	3/8"	17.5	22.0	Plated Malleable Iron	6
DD*	1/2"	20.5	24.0	Plated Malleable Iron	6
B4*	1/2"	24.0	27.0	Plated Malleable Iron	12
B5*	1/2"	27.0	30.0	Plated Malleable Iron	12
BU9S	3/4"	29.5	32.5	Plated Malleable Iron	21
BU9	3/4"	30.0	33.0	Plated Malleable Iron	21
B9*	3/4"	33.0	38.0	Plated Malleable Iron	21
B10*	3/4"	38.0	43.0	Plated Malleable Iron	21
BB4	1/2"	24.0	27.0	Brass	12
BBU9	3/4"	30.0	33.0	Brass	21
BB9	3/4"	33.0	38.0	Brass	21
RB4	1/2"	24.0	27.0	Stainless Steel	12
RBU9	3/4"	30.0	33.0	Stainless Steel	21
RB9	3/4"	33.0	38.0	Stainless Steel	21

* Global Investment Cast Carbon Steel

BOSS™ CLAMP - 4 BOLT TYPE



PART NO.	HOSE I.D. SIZE	HOSE O.D. (MM)		MATERIAL	TORQUE IN/LBS
		FROM:	TO:		
968†	1/2"	23.0	26.0	Plated Malleable Iron	6
156**	1"	35.5	40.0	Plated Malleable Iron	21
BU14	1"	39.0	43.5	Plated Malleable Iron	21
B14	1"	43.0	49.0	Plated Malleable Iron	21
B15	1"	49.0	54.0	Plated Malleable Iron	21
BU18	1 1/4"	38.0	45.5	Plated Malleable Iron	40
187**	1 1/4"	43.0	47.5	Plated Malleable Iron	21
BU19	1 1/4"	45.5	53.0	Plated Malleable Iron	40
206**	1 1/4"	47.5	52.5	Plated Malleable Iron	21
B19	1 1/4"	54.0	60.0	Plated Malleable Iron	40
BU22	1 1/2"	46.0	51.0	Plated Malleable Iron	40
B22	1 1/2"	51.0	56.0	Plated Malleable Iron	40
212**	1 1/2"	51.0	54.0	Plated Malleable Iron	21
225**	1 1/2"	52.5	57.0	Plated Malleable Iron	40
BU24	1 1/2"	55.5	60.0	Plated Malleable Iron	40
B24	1 1/2"	60.0	65.0	Plated Malleable Iron	40
B25	1 1/2"	65.0	70.0	Plated Malleable Iron	40
250**	2"	57.0	63.5	Plated Malleable Iron	40
BU28	2"	59.5	64.5	Plated Malleable Iron	60
275**	2"	63.5	70.0	Plated Malleable Iron	40
BU29	2"	63.5	71.0	Plated Malleable Iron	60
B29	2"	70.0	78.0	Plated Malleable Iron	60
306**	2"	70.0	78.0	Plated Malleable Iron	60
B30	2"	78.5	87.5	Plated Malleable Iron	60
350**	2 1/2"	78.0	89.0	Plated Malleable Iron	60
BU34	2 1/2"	78.5	87.5	Plated Malleable Iron	60
B34	2 1/2"	89.0	100.0	Plated Malleable Iron	150
375**	3"	89.0	95.0	Plated Malleable Iron	60
BU35	3"	89.0	100.0	Plated Malleable Iron	150
401**	3"	95.5	101.5	Plated Malleable Iron	150
B35	3"	96.5	103.0	Plated Malleable Iron	150
418**	3"	101.5	106.5	Plated Malleable Iron	200
B39	3"	103.5	113.0	Plated Malleable Iron	200
450**	3"	106.5	114.0	Plated Malleable Iron	200
BBU14	1"	39.0	43.5	Brass	21
BB14	1"	43.0	49.0	Brass	21
BB19	1 1/4"	54.0	60.0	Brass	40
BBU24	1 1/2"	55.5	60.0	Brass	40
BB24	1 1/2"	60.0	65.0	Brass	40
RBU14	1"	39.0	43.5	Stainless Steel	21
RB14	1"	43.0	49.0	Stainless Steel	21
RB19	1 1/4"	54.0	60.0	Stainless Steel	40
RBU24	1 1/2"	55.5	60.0	Stainless Steel	40
RB24	1 1/2"	60.0	65.0	Stainless Steel	40
RBU29	2"	63.5	71.0	Stainless Steel	60
RB29	2"	70.0	78.0	Stainless Steel	60

* 4 Gripping Fingers.

† These clamps are not to be used with GF81, GB26, WF81, B26, RGF81, RGB26, BGF81, BGB26, RWF81, RB26 Boss™ Stems.

BOSS™ CLAMP - 6 BOLT TYPE



PART NO.	HOSE I.D. SIZE	HOSE O.D. (MM)		MATERIAL	TORQUE
		FROM:	TO:		
BS39	3"	108.0	122.0	Plated Malleable Iron	150
B45	4"	117.5	127.0	Plated Malleable Iron	150
BS49	4"	123.5	133.5	Plated Malleable Iron	200
BU49	4"	33.5	142.0	Plated Malleable Iron	200
B49	4"	140.5	151.0	Plated Malleable Iron	200
750	6"	174.5	187.0	Plated Malleable Iron	200
850	6"	190.0	203.0	Plated Malleable Iron	200

Recommended torque rating in ft.lbs (for Malleable Iron and Stainless Steel Clamps only).

Steam Hose Fittings and Couplings - BS EN 14423:2004

- Sizes:** DN13 to DN25.
- Pressure (All sizes):** Maximum working pressure 18 bar.
- Temperature:** Maximum working temperature:
 Steam +210°C (410°F)
 Hot Water +120°C (248°F)
- Details:** Suitable for fixing to steam hoses to BS EN 14423:2004 with safety clamps.
 All steam fittings are supplied with corresponding brass safety clamps.



BS EN 14423:2004 STEAM HOSE FEMALE COUPLING			
PART NO.	HOSE SIZE	THREAD	MATERIAL
SCF13x6 BR	13 x 6	1/2" BSP PI.	Brass
SCF19x7 BR	19 x 7	3/4" BSP PI.	Brass
SCF25x7.5 BR	25 x 7.5	1" BSP PI.	Brass



BS EN 14423:2004 STEAM HOSE MALE COUPLING			
PART NO.	HOSE SIZE	THREAD	MATERIAL
SCM13x6 BR	13 x 6	1/2" BSPT	Brass
SCM19x7 BR	19 x 7	3/4" BSPT	Brass
SCM25x7.5 BR	25 x 7.5	1" BSPT	Brass

Note: All BS EN 14423:2004 Couplings are available to special order only, Minimum quantities may apply.
 All couplings supplied with clamp.

FOR DIN TYPE CLAMPS SEE PAGE 74



J

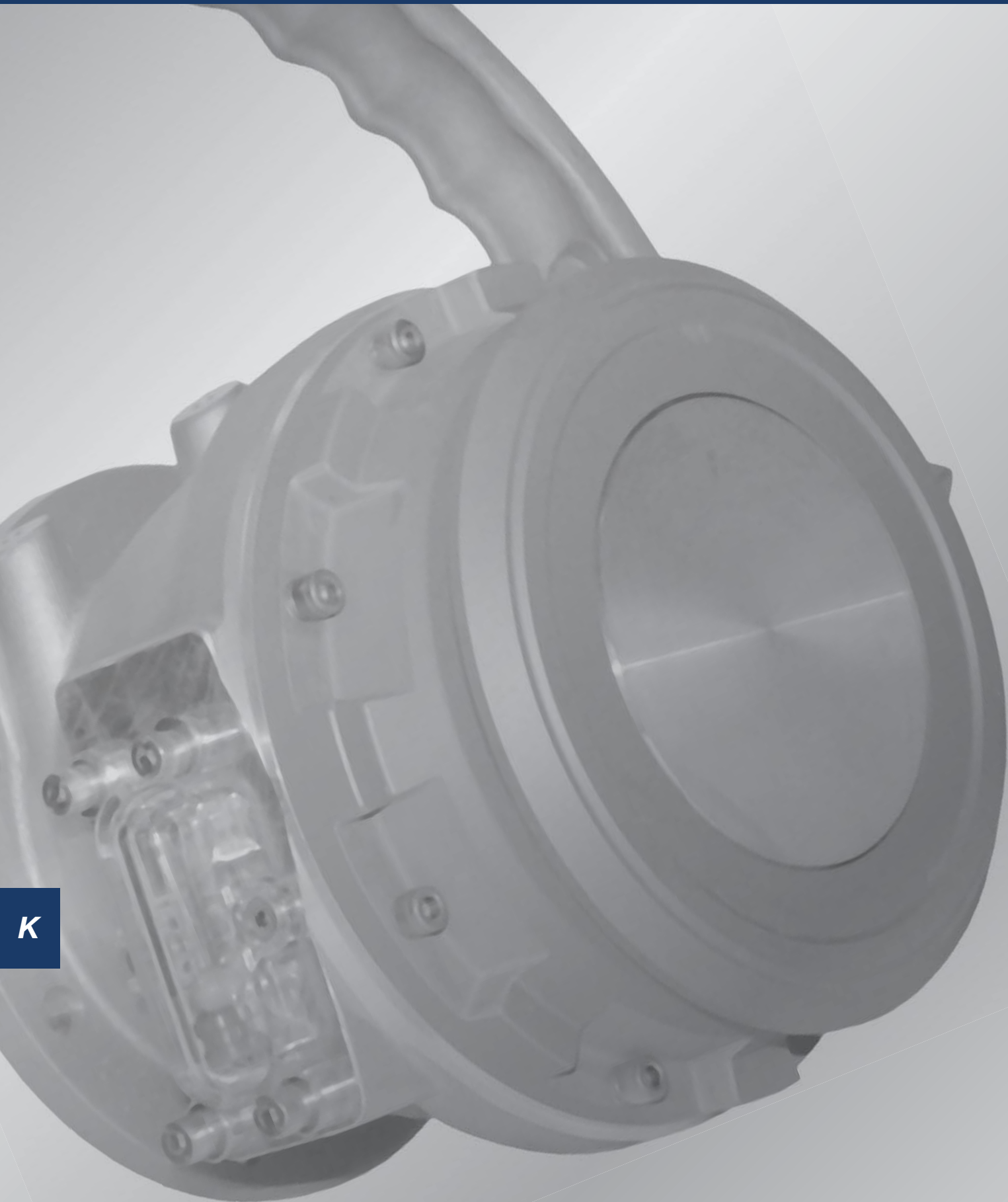

K

Tanker, Overfill Prevention & Storage Tank Products

Dry Bulk Products	351-359
Bayco Petroleum Products.....	360-368
FloTech™ Overfill Prevention Products	369-381
Swivel Joints	382-387
Dry Disconnect Couplings.....	388-389
Dry Disconnect Adapters	390
Dry Break Cam & Groove Couplings	391-392
Dry Break Cam & Groove Adapters	393
Aluminium Storz Couplings	394-397
Tank Wagon Couplings EN 14420-6:2004	398
Tank Wagon Spares & Seals EN 14420-6:2004	399
Low Pressure Tank Equipment.....	400

K

**FOR A FULL RANGE OF COMPOSITE & RUBBER HOSES
TO COMPLEMENT THESE FITTINGS SEE SECTION F**



Tanker & Storage Tank Products

Dixon offers a comprehensive range of equipment for use on dry bulk & petroleum tankers including overfill protection equipment. The range is supplemented by an excellent range of storage tank equipment including, pressure & vacuum relief valves, emergency relief valves and gauge hatches.



K

Dry Bulk Tanker Products

- Air Relief Valves.
- Vacuum Relief Valves.
- Caps, Adapters and Reducers.
- Filtration Systems.
- Swing Check Valves.
- Butterfly Valves.

Petroleum Tanker Products

- API Valves / Drop Adapters.
- Vapour Valves, Couplers & Caps.
- Vapour Elbows & Air Interlocks.
- Shut off and pressure Nozzles.
- Flanged Sight Flow Indicators.
- Pipe Caps & Reducers.
- FloTech Overfill Prevention.

Low Pressure Tank Equipment

- Vacuum Relief Valves.
- Pressure Relief Valves.
- Combined Pressure and Vacuum.
- Emergency Relief Valves.
- Gauge Hatches.

Dry Bulk

Dixon Dry Bulk products are designed for use with bulk trailers and truck blowers for the pneumatic transfer of dry bulk commodities such as powders, grains and plastic pellets. Other industrial applications are possible when pneumatic control of air or dry products is required.

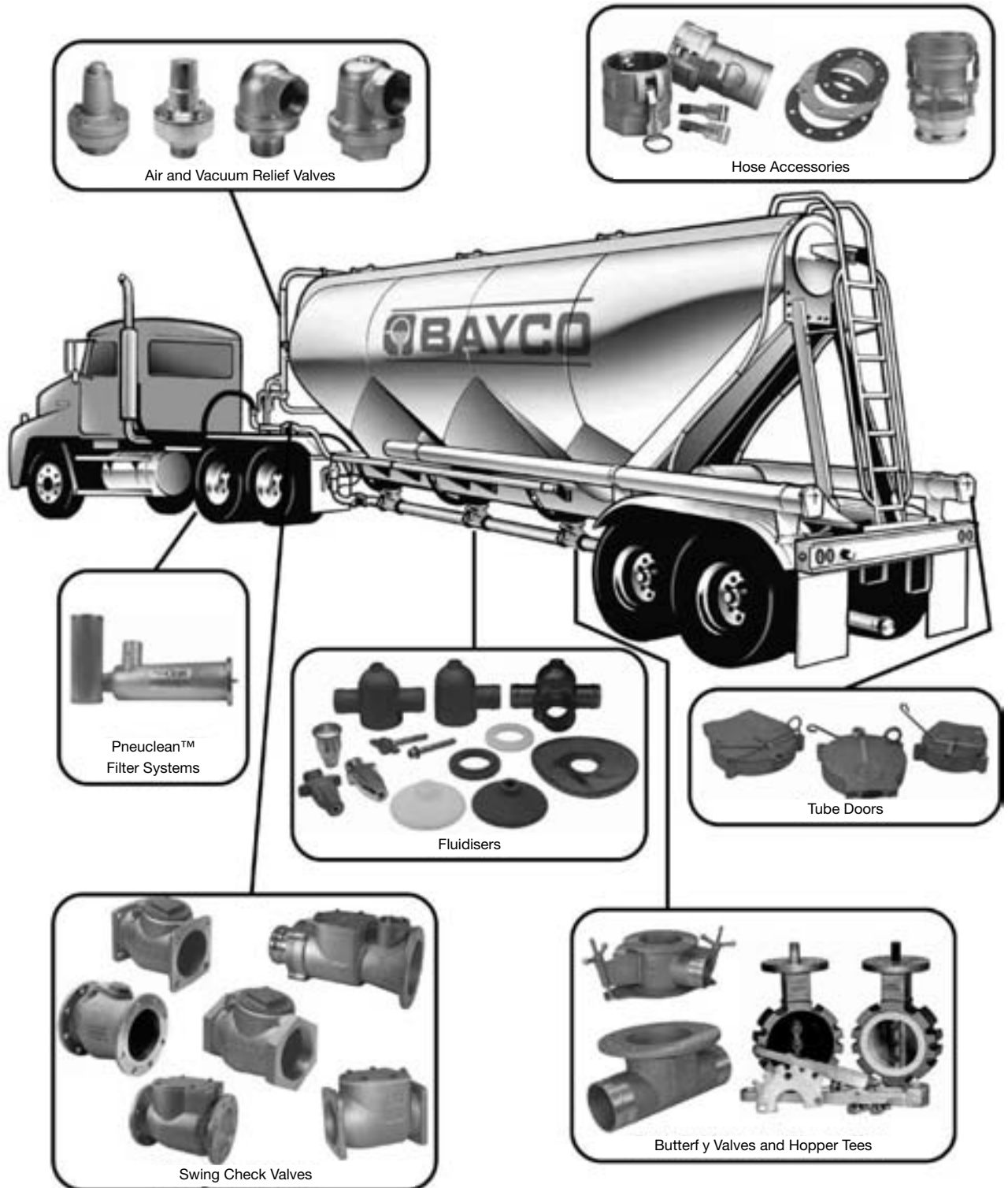

K

Air Relief Valves

- Designed to relieve air pressure at a specific pressure setting (customer to advise when ordering - typical setting 15-25 psi)
- Air Relief Flow Rates:
 - A2180 up to 500 SCFM
 - A2182 up to 1400 SCFM
 - A3180 up to 1300 SCFM
- A choice of setting tolerances are provided. In addition to conventional field duty tolerances of +3/-0 psi, offers OEM tolerances of +1/-0 psi. The tighter tolerance air reliefs are designated with the prefix A, (A2180, A3180, A2182). Both conventional field duty and OEM tolerance products are of identical construction, however OEM models are identified with an A imprinted before the setting stamp

NOTE: Adjustable models, (A2180ADJ, A3108ADJ) are only available with OEM settings

Relief Valve Flow Rates vary depending on the preset relief pressure, for specific relief rates contact Dixon.

Features:

- High Grade Diaphragms – White, food grade, and high temperature elastomers for all models
- Suitable for high temperature (to 200°C) and food grade service
- Tamper proof stainless steel cup seals
- Available in a female thread version
- Model 2182 has Silicon rubber poppet which reduces tendency to cake – cement, lime etc

Safety Note: Air/vacuum relief valves must be regularly inspected, cleaned and maintained. Product particles can prevent the valve from fully reseating which can lead to early opening/leakage from the valve or can prevent it from opening at all. For ease of removal and installation, to allow for inspections, cleaning and maintenance all 2180 and 2182 series air relief valves are available with either male cam and groove or victaulic grooved connections.

Designed for trailer service



PART NO.	DESCRIPTION
2180/xx	2" Female NPT
A2180/xx	2" Female NPT
3180/xx	3" Female NPT
A3180/xx	3" Female NPT



PART NO.	DESCRIPTION
2180V/15	2" Grooved End

Set at 15 psi



Shown with optional Safety Lanyard (CAL25) attached.



PART NO.	DESCRIPTION
2180B/15	2" Adapter

Set at 15 psi



Shown with optional Safety Lanyard (CAL25) attached.

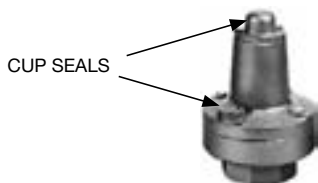

PART NO.	DESCRIPTION
A2180/xxADJ	2" Female NPT
A3180/xxADJ	2" Female NPT

Adjustable models allow an adjustment of + or - 3 psi from specified setting. Designed for trailer service. /xx refers to the choice of pressure settings provided. Please request the required settings when ordering.

Designed for high capacity blower or trailer service



PART NO.	DESCRIPTION
2182/xx	2" Male NPT
A2182/xx	2" Male NPT
2182B/xx	2" Adapter
2182V/xx	2" Grooved End



PART NO.	DESCRIPTION
2182F/xx	2" Female NPT

/xx refers to the choice of pressure settings provided. Please request the required settings when ordering.

Pneuclean™ Pneumatic Filtration System

The Pneuclean™ unit is designed to remove microscopic particles generated by blowers during pneumatic conveying of contaminant-sensitive dry bulk products. Contaminants such as Iron and Hydrocarbons are produced by blowers and can adversely affect dry products such as plastic pellets and food materials.

These filter units are typically used on dry bulk tanker trucks and placed after the blower and before the bulk storage tanker. This in-line pneumatic system is also suitable for industrial applications or wherever microscopic filtration (up to 4 microns) of impurities is required.

Standard units employ 4" inlets and outlets. However, 3" plumbing can be used with available weld-on 4" x 3" female NPT adapters.

Special cartridge-style filter elements have a typical life expectancy of approximately 12 months or 2000 hrs. of service.

4" AW and 4" DW Aluminium fittings may be butt-welded to filter inlet to allow quick coupler connection of hose.

4" inlet (can be converted to 3" by use of 4" x 3" adapter)

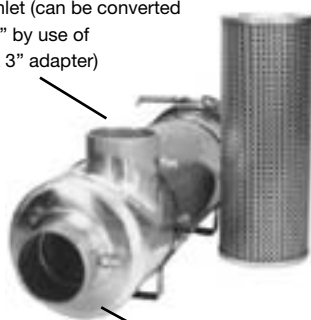

Stainless Steel cartridge with microporous, semi-permeable PTFE membrane filter element.

4" outlet (can be converted to 3" by use of 4" x 3" adapter)

PART NO.	DESCRIPTION
PC5000	4" Pneuclean complete housing with filter
PART NO.	REPLACEMENT PARTS DESCRIPTION
PC5001	Filter
PC5003	Mounting Bracket
PC5004	V-clamp
PC5005	Lid O-ring
PC5006	Bottom Gasket
PC5007	Lid w/Adjusting nut

In-Line High Pressure Air Filtration for 4" Air Lines

- FDA Medium with 99.99% maximum efficiency at 4 microns.
- Maximum air flow 1000 CFM's
- Back pressure only .05 psi
- Temperature range -45° to 230°C
- Average 12 month filter cartridge lifespan
- Quick release V-clamp for easy inspection
- Overall weight 26 lbs (11.8kg)

Swing Check Valves

- High flow body design
- Drop in flapper assembly
- High temperature white food grade seal
- Easy maintenance inspection lid
- Captive springs and shaft to prevent contamination
- Stainless Steel hardware



3030SQ



3090MA

SWING CHECK VALVES	
PART NO.	DESCRIPTION
3030SQ	3" Square Flange Swing Check Valve
3090M	3" Swing Check Manifold
3090MA	3" Swing Check Manifold with 3" Adapter
3090MB	3" Swing Check Manifold with 4" Adapter
3030SK	Security Kit For 3" Swing Check Manifold
3090MS	3" Swing Check Manifold with Security Kit installed
3090MAS	3" Swing Check Manifold with 3" Adapter and Security Kit installed
3090MBS	3" Swing Check Manifold with 4" Adapter and Security Kit installed

3" and 4" Swing Check Valves

- Cast Aluminium bodies with Bronze inspection caps
- Safety flapper assembly - all flapper assemblies are drilled and pinned and will not come apart
- Choice of seals: metal-to-metal, Buna or Silicon Rubber seals
- Choice of models with or without spring loaded flapper
- Full flow design - flappers swing out of flow path for maximum flow and low resistance
- Designs with large caps allow flapper repair/rebuild on unit

Check valves allow one way directional flow only. They are used as a protective safety device to prevent flow reversal should back pressure result. These valves are designed specifically for service with pneumatic equipment which transfers dry bulk commodities.



3" ROUND FLANGED (TTMA)	
PART NO.	DESCRIPTION
3000N	Metal-to-metal seal
3000SP	Metal-to-metal seal & spring loaded flapper
3000B	Buna Rubber seal
3000S	Silicon Rubber seal
3000BSP	Buna seal & spring loaded flapper
3000SSP	Silicon Rubber seal & spring loaded flapper

K



3" SQUARE FLANGED (TTMA)	
PART NO.	DESCRIPTION
3001SQN	Metal-to-metal seal
3001SQSP	Metal-to-metal seal & spring loaded flapper
3001SQB	Buna Rubber seal
3001SQS	Silicon Rubber seal
3001SQBSP	Buna seal & spring loaded flapper
3001SQSSP	Silicon Rubber seal & spring loaded flapper



3" THREADED ENDS (NPT)	
PART NO.	DESCRIPTION
3000TE	Metal-to-metal seal
3000TESP	Metal-to-metal seal & spring loaded flapper
3000TEB	Buna Rubber seal
3000TES	Silicon Rubber seal
3000TEBSP	Buna seal & spring loaded flapper
3000TESSP	Silicon Rubber seal & spring loaded flapper

Gaskets should be purchased separately.



4" ROUND FLANGED (TTMA)	
PART NO.	DESCRIPTION
4040RD	Metal-to-metal seal & spring loaded flapper

4" THREADED ENDS (NPT)	
PART NO.	DESCRIPTION
4040TE	Silicone seal, spring loaded flapper



2" Swing Check Valves

- Aluminium cast, square flanged and threaded end models
- Self-aligning, moulded "white food grade EPDM" rubber flapper assembly (176°C / 350°F) with externally mounted springs, to prevent ingestion of parts
- Easy open (no tools required) inspection cap
- Full flow performance

2" SWING CHECKS	
PART NO.	DESCRIPTION
3020SQ	2" Square Flange
3020TE	2" Female NPT

Horizontal Swing Check Valves

- Swing Check Valves are designed to prevent backflow in plumbing and liquid piping systems, while offering full flow performance with a minimum of turbulence or pressure loss
- A positive seating disc allows flow only in one direction and a screw-in cap provides easy access for periodic cleaning
- For horizontal or vertical use
- Rated to 200 psi WOG
- Brass body & disc
- Temperature range (-4°C to 66°C / -20°F to 150°F)



FEMALE NPT x FEMALE NPT	
PART NO.	DESCRIPTION
SWCV50	1/2"
SWCV75	3/4"
SWCV100	1"
SWCV125	1 1/4"
SWCV150	1 1/2"
SWCV200	2"
SWCV300	3"

In-line Sight Glass

- Designed for dry bulk transfer applications
- Available in combination of 3" and 4" coupler or adapter ends
- Includes:
 - Aluminium bodies
 - Buna seals
 - Acrylic sight glasses
 - Stainless steel hardware
 - Bronze cam arms (where applicable)



PART NO.	DESCRIPTION
3544CA	4" Coupler x 4" Adapter
3533CA	3" Coupler x 3" Adapter
3543CA	4" Coupler x 3" Adapter
3534CA	3" Coupler x 4" Adapter
3533AA	3" Adapter x 3" Adapter
3544AA	4" Adapter x 4" Adapter
3534AA	3" Adapter x 4" Adapter
3544CC	4" Coupler x 4" Coupler
3533CC	3" Coupler x 3" Coupler
3543CC	4" Coupler x 3" Coupler

K

Butterfly Valves - 400 Series

Housing:	Aluminium
Discs:	Type 316 Stainless or Nodular Iron
Stem Packing:	Buna-N
Stem Bushings:	Thermal plastic polymer, top and bottom
Resilient Seat:	Nitrile
Handle:	High strength 713 Alloy Aluminium with retrogressive re-aging process - stronger than industry standard Cast Iron handles. Stainless Steel spring and locking lever pin
Throttling Plate:	Five position, high strength Aluminium Alloys

Features:

- Aluminium Body
- Nodular Iron Disc
- 17-4 SS Stem
- Nitrile, FDA approved Black Seat



NODULAR IRON					
COMPLETE VALVE WITH NODULAR IRON DISC		NODULAR IRON REPLACEMENT DISCS		BLACK REPLACEMENT NITRILE SEATS	
PART NO.	SIZE	PART NO.	SIZE	PART NO.	SIZE
2-400-1500	2"	2-400-422237F	2"	2-400-422500	2"
3-400-1500	3"	3-400-422237F	3"	3-400-422500	3"
4-400-1500	4"	4-400-422237U	4"	4-400-422500	4"
4A-400-1500	4" TTMA	5-400-422237U	5"	4A-400-422500	4" TTMA
5-400-1500	5"	6-400-422237U	6"	5-400-422500	5"
6-400-1500	6"			6-400-422500	6"

Handles should be ordered separately.

Features:

- Aluminium Body
- 316 SS Disc
- 17-4 SS Stem
- Nitrile, FDA approved White Seat



STAINLESS STEEL					
COMPLETE VALVE WITH 316 STAINLESS STEEL DISC		316 STAINLESS STEEL REPLACEMENT DISCS		WHITE REPLACEMENT NITRILE SEATS	
PART NO.	SIZE	PART NO.	SIZE	PART NO.	SIZE
3-400-3501	3"	2-400-422209F	2"	2-400-422501	2"
4-400-3501	4"	3-400-422209F	3"	3-400-422501	3"
5-400-3501	5"	4-400-422209U	4"	4-400-422501	4"
6-400-3501	6"	5-400-422209U	5"	4A-400-422501	4" TTMA
		6-400-422209U	6"	5-400-422501	5"
				6-400-422501	6"

Handles should be ordered separately.

Butterfly Valves - 390 Series

Housing:	Aluminium
Discs:	Type 316 Stainles
Body Screws:	Cadmium Plated Steel
Stem Packing:	Buna
Stem Bushings:	Thermal plastic polymer, top and bottom
Resilient Seat:	Nitrile
Handle:	High strength 713 Alloy Aluminium with retrogressive re-aging process - stronger than industry standard Cast Iron handles. Stainless Steel spring and locking lever pin
Throttling Plate:	Five position, high strength Aluminium Alloy

Features:

- 2 Piece Aluminium Body
- One piece 316 SS Disc and Stem
- Nitrile, FDA approved White Seat



STAINLESS STEEL					
COMPLETE VALVE WITH 316 SS DISC		316 STAINLESS STEEL REPLACEMENT DISCS		WHITE REPLACEMENT NITRILE SEATS	
PART NO.	SIZE	PART NO.	SIZE	PART NO.	SIZE
3-390-828501	3"	3-390-209F	3"	3-400-422501	3"
4-390-828U501	4"	4-390-209U	4"	4-400-422501	4"
5-390-828U501	5"	5-390-209U	5"	5-400-422501	5"
6-390-828U501	6"	6-390-209U	6"	6-390-363501	6"

Handles should be ordered separately.

For 6" 390 series valve, use special handle 400-206-65.

K

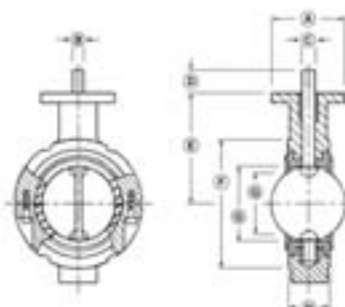

DIMENSIONS & WEIGHTS										
SIZE	DIMENSIONS									WEIGHT IN LBS.
	A	B	C	D	E	F	G	H	Q	
2"	4.000	.375	.563	1.250	3.938	4.125	2.125	1.625	1.688	3
3"	4.000	.375	.563	1.250	4.875	5.375	3.125	1.750	2.875	4
4"	4.000	.438	.625	1.250	6.000	6.875	4.125	2.000	3.875	7
5"	4.000	.438	.625	1.250	6.000	7.625	5.188	2.125	5.000	9
6"	4.000	.438	.625	1.250	6.500	8.750	6.125	2.125	6.000	9

NOTE: Q dimension is the minimum allowable inside diameter of the pipe or mating flange.

Butterfly Valve Accessories



ALUMINIUM HANDLE KIT

PART NO.	SIZE
206-23-5	2" and 3"
206-46-5	4" thru 6"
400-206-65*	6" - 390

BUSHING & PACKING KITS

PART NO.	SIZE
2-3-400-99-BPKIT	2" and 3"
4-6-400-99-BPKIT	4" thru 6"
6-99-400BPKIT*	6"

316 STAINLESS SCREW SETS

PART NO.	SIZE
2-3-213	2" and 3"
4-5-6-213	4" thru 6"

17-4 STAINLESS STEMS

PART NO.	SIZE
2-400-422240	2"
3-400-422240	3"
4-400-422240	4"
5-400-422240	5"
6-400-422240	6"

Includes handle plate kit and handle/lever assembly.

*Use on 6" 390 series valves

Petroleum Tanker Products

Dixon products are engineered for dependable, long service life and designed for easy, low cost maintenance. Where possible, modular systems are incorporated with common parts to minimise inventory of repair items.

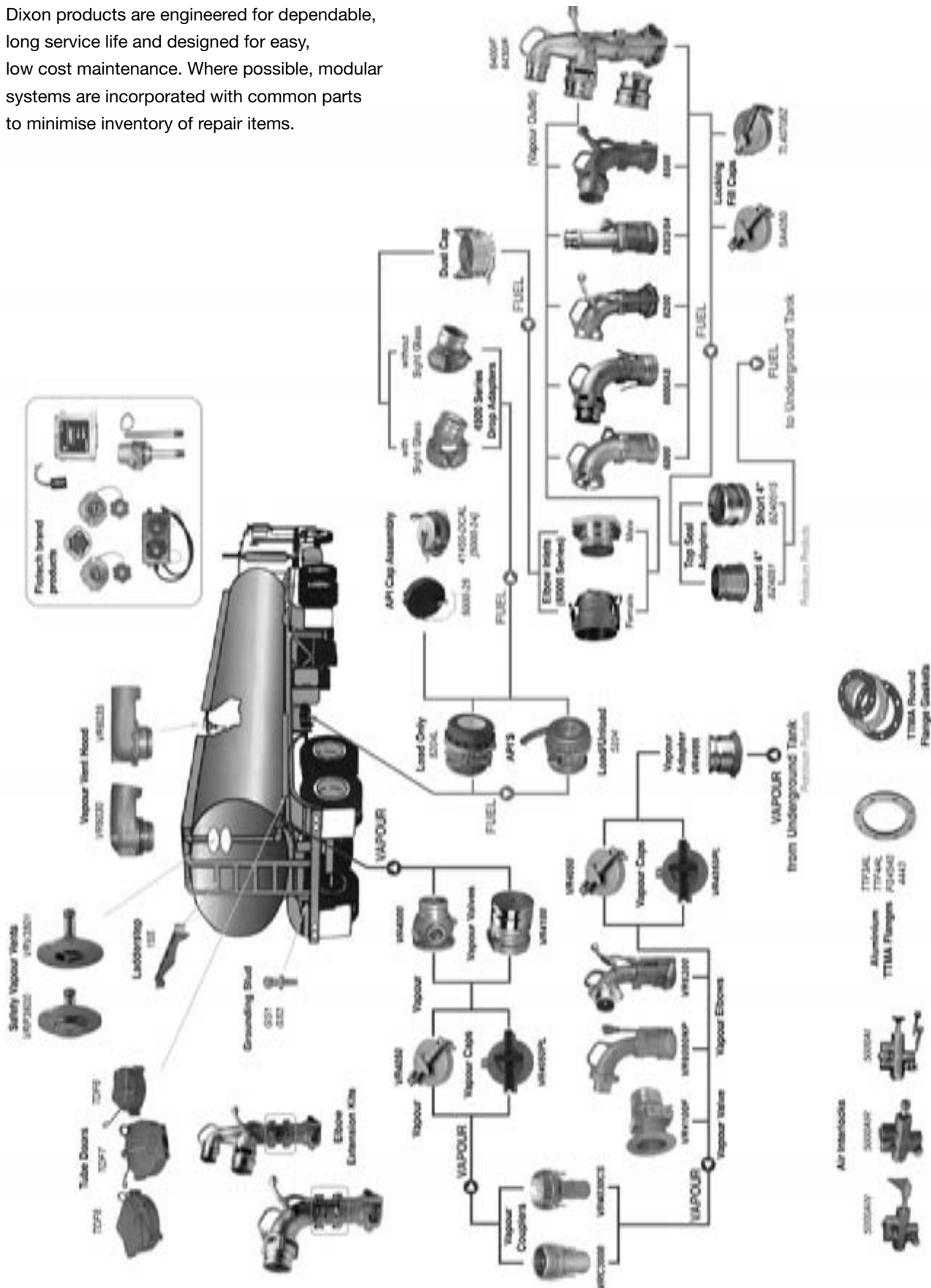

K

4" API Valves

API Valves are used for bottom loading and unloading of petroleum tankers. Valve nose shape and opening comply with American Petroleum Institute standard (API RP-1004) enabling Dixon API valves to interchange with competitor items made to the same specification. Two styles are available; a load only model without handle and a load/unload model with a handle to allow manual opening.

- Unique flow and fluid level sight indicators are available
- Load/unload versions feature an ergonomically curved handle that opens with a short 62° stroke.
Can be ordered with a fixed or removable handle
- Chemical resistant crank seals and poppet seal (PTFE seals optional)
- Any required maintenance is simplified, can be completely rebuilt without removing the valve from the tank
- The ALH (anodised aluminium hard coat) nose ring can be rotated to provide a fresh cam service to compensate for wear



API LOAD /UNLOAD VALVE	
PART NO.	DESCRIPTION
5204NG	Fixed handle, without sight glass, ALH nose ring, Baylast seal
5204	Fixed handle, sight glass, ALH nose ring, Baylast seal
5204C	Removable handle*, sight glass, ALH nose ring, Baylast seal
5204NGC	Removable handle*, without sight glass, ALH nose ring, Baylast seal
5204SNG	Fixed handle, without sight glass, ALH nose ring, stainless spring for crude oil, Baylast seal
5204TNG	Fixed handle, without sight glass, ALH nose ring, PTFE seals
5204NGV	Fixed handle, without sight glass, Viton® seals

* Removable handle for Canadian market



API LOAD ONLY VALVE	
PART NO.	DESCRIPTION
5204L	Load only API valve with sight glass, ALH nose ring
5204LNG	Load only API valve without sight glass, ALH nose rings

K

API Bottom Rack Loading Fitting

Dixon API coupler uses a snap on connection where the coupling action is automatic upon contact with the API adapter. The coupler is completely modular so it can be built with various face seal combinations to be compatible with different alternative fuel, performance levels and applications. Two models are available: bonded nose seal and replaceable nose seal.

Material Specifications:

- Body: hard coated anodized AL 356 T6
- Shroud: hard coated anodized AL 356 T6, SS insert
- Link, shaft, pin and crank: hardened 17-4PH stainless steel
- Cam: CF8M stainless steel
- Poppet and bearing: ZA-12
- Seal options: Baylast, Viton-B®, Viton® GFLT

Chemical Compatibility (Baylast seals):

- Gasoline
- Diesel
- Avgas
- 100% ethanol
- 100% methanol
- B2 to B20 biodiesel blends

Technical Specifications:

- Weight: 9.1 kgs.
- Maximum working pressure: 150 PSI
- Peak surge pressure: 350 PSI
- Operating temperature:
Viton® seals: -29°C (-20°F) to 204°C (+400°F)
Baylast seals: -29°C (-20°F) to 121°C (+250°F)
- Maximum flow rate: 600 GPM
- Pressure drop: 3 to 4 PSI

Chemical Compatibility (Viton-B® seals):

- Gasoline
- Diesel
- Jet fuel
- Avgas
- 100% ethanol
- 100% methanol
- 100% biodiesel
- Any blend of the above fluids

- 4" TTMA inlet mounting flange
- 5 cam design for easy alignment and tight connection
- Ball-end handle for easy, comfortable operation
- No special tools needed for maintenance
- Shaft seals can be changed without removing coupler from loading arm
- Fully compliant with API RP1004:2003 specifications
- Fully interlocked collar can not be opened when connected and can not be disconnected when opened
- One piece bonded nose seal ensures long life and cannot be washed out
- Optional replaceable nose seal for quick replacement without removal from loading arm



bonded nose seal
model - 5300

API BOTTOM RACK LOADING FITTING

BONDED NOSE SEAL NO.	REPLACEMENT NOSE SEAL NO.	SEAL MATERIAL
5300 5300B 5300G	5400 5400B 5400G	Baylast Viton-B® Viton GFLT

API Dust Caps



API DUST CAPS

PART NO.	DESCRIPTION
41450-DCAL	Aluminium API cap with flat gasket
5000-24	Aluminium API cap with O-ring gasket
5000-25	Nylon API cap with flat gasket, pad lockable arm

Gravity Drop Adapters

Gravity drop adapters attach and seal directly against openable API's and allow drop hose with standard cam and groove couplers to clamp on and transfer petroleum from the API. Dixon manufactures two styles of gravity drop adapters: 1) standard one piece and, 2) a 2 piece bolt together design with sight glass. Both are Dixon quality cast construction with bronze cam arms and Buna O-Ring seals (Viton O-Rings available upon request).

- Quality cast aluminium body with inside lip to hang on API while clamping
- Inexpensive replacement of Buna O-Ring seal (Viton seal available)
- Bronze cam arms with stainless steel pins, finger rings



STANDARD ONE PIECE BODY	
PART NO.	DESCRIPTION
4530	3" outlet
4540	4" outlet
41450-DCAL	4" API Dust Cap (not shown)
31440-225AL	3" x 4" API Offloading 10° Angle Spout, Flat gasket (not shown)
41440-225AL	4" x 4" API Offloading 10° Angle Spout, Flat gasket (not shown)

- Consists of a 4500 ring assembly and an outlet which contains mounting bolts, sight glass and seals
- Customer assembly required (see sketch)
- Order 4500 ring and outlets separately



TWO PIECE DESIGN WITH SIGHT GLASS	
PART NO.	DESCRIPTION
4500	Ring only
4501	3" Male x 4" TTMA Flange x 22 1/2°
4502	4" Male x 4" TTMA Flange x 22 1/2°
4503	4" Male x 4" TTMA Flange Straight
4503SPECIAL	4" Male x 4" TTMA Flange Straight, no sight glass
4504	4" Female x 4" TTMA Flange x 22 1/2° Coupler
4501ASSM	3" Male Adapt. 22 1/2° x API Cplr. (4501 & 4500)
4502ASSM	4" Male Adapt. 22 1/2° x API Cplr. (4502 & 4500)
4503ASSM	4" Male Adapt. Straight x API Cplr. (4503 & 4500)
4504ASSM	4" Female Cplr. 22 1/2° x API Cplr. (4504 & 4500)

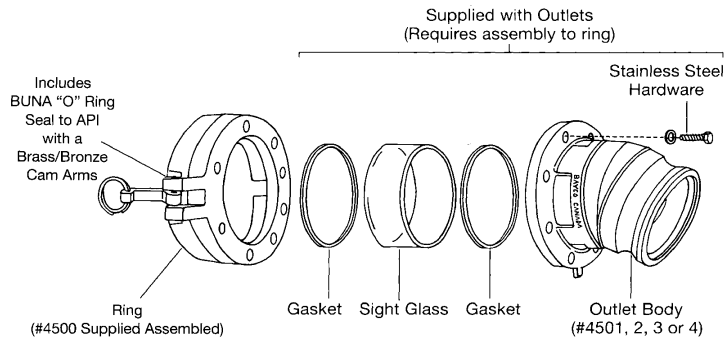

Sketch illustrates assembly of 2 piece drop adapter

Vapour Valves

- Bulb design for maximum vapour flow (low resistance) for fast loading of tankers
- With angled acrylic sight glasses (2) and drain plug, allows viewing and drainage of fluids if in system
- Quality cast aluminium construction
- 4" TTMA flange
- With air interlock mount (use air interlock 5000AIV if required)



PART NO.	SIZE
VR4000	4"

- Features easy seal replacement while on tanker
- Heavy duty cast aluminium body
- 4" female NPT
- With air interlock mount (use air interlock 5000AI if required)
- Available as special order without poppet (VR4100NP)



PART NO.	SIZE
VR4100	4"

Vapour Caps

- Lockable push/pull cap for vapour valves (VR4000 & VR4100) or vapour adapter (VR4086)
- Aluminium cap and arms with bronze locking cam and Buna gasket
- Painted orange

K



PART NO.	DESCRIPTION
VR4050AL VR4050ALC 400-G-BU	Aluminium cap Aluminium cap with chain Replacement gasket



PART NO.	DESCRIPTION
VR4050PL VR4050PLC 40018BN	Ultra lightweight nylon cap Ultra lightweight nylon cap with chain Replacement gasket

Vapour Hose Couplers

- For use with vapour hose
- Cast aluminium body
- Buna gasket
- VR4030CS-AL has Viton poppet seal



PART NO.	DESCRIPTION
VRC3000AL	3" coupler with probe x 3" hose shank
400-CVR-AL	4" coupler with probe x 4" hose shank
4030-CVR-AL	4" coupler with probe x 3" hose shank
VR4030CS-AL	4" coupler with poppet & probe x 3" hose shank
4030-DAVR-AL	4" coupler with poppet & probe x 3" adapter
4030-DVR-AL	4" coupler with probe x 3" female NPT
400-DVR-AL	4" coupler with probe x 4" female NPT

Sequential Vapour Vents

Sequential vapour vents are used for venting tank vapours during the bottom loading and unloading of petroleum tankers. These pneumatically activated vapour vents can either be installed to open sequentially or to open independently. Vapour vents available to suit either 16" or 20" tank manholes.

- Highest flow vapour recovery vents on the market
- Baylast seals resist chemical attack from fuel additives and alcohol
- Floating piston design ensures long life and resists poppet sticking
- Can be used for both sequential and non-sequential operation
- Quick and easy to rebuild with simple hand tools
- Tested vapour tight to 36 psi, certification 49 CFR 178.345-5
- Sealed system eliminates common leak points and improves reliability



PART NO.	DESCRIPTION
VR6030SQ	For 16" manhole, mounting ring attachment
VR6035SQ	For 20" manhole, 3" TTMA flange attachment

Air Interlocks

- Mounts to API's, vapor valves and safety bars
- Rugged solid bayloy body for dependable service and superior corrosion resistance
- Choice of standard piston end or paddle end (for bulb style vapor valve)
- Adjustable stroke to accommodate length variations
- Includes 1/4" x 1 3/4" stainless steel mounting bolts



PART NO.	DESCRIPTION
5000AI	Standard 1" button plunger pneumatic interlock
5000AIV	
5000AIR	
5000AIS	
5000AIST	1 1/2" button plunger pneumatic interlock
5000S	
5000ST	Replacement 1 1/2" large button

Repair kits and replacement parts available.

Ball Nozzles for Bulk Delivery

The Bayco brand ball nozzle uses a full port ball valve for high flow rate at a given inlet pressure. The internal flow path is computer designed to provide low pressure drop across the nozzle. Lower pressure drop permits higher flow rates at lower pressure, reducing foaming or backups.

Our unique swivel design permits low temperature operation without leakage around the O-ring seals. The swivel freely rotate seven at temperatures as low as -40°C (-40°F) and pressures as high as 100 PSI. Through-hardened chrome steel roller balls and hardened carbon steel ball race provide long service life.

- Standard nozzle uses a 3 PSI check valve. An optional 5 PSI check valve is available as a field replaceable kit
- Available with a field replaceable Scully compatible connector or tube spout



BALL NOZZLES FOR BULK DELIVERY	
PART NO.	DESCRIPTION
BL062	1¼" NPT swivel inlet x quick fit outlet
BL064	1½" NPT swivel inlet x quick fit outlet
BL066	1¼" NPT swivel inlet x 1¼" NPT with spout
BL066NS	1¼" NPT swivel inlet x 1¼" NPT without spout
BL068	1½" NPT swivel inlet x 1¼" NPT with spout
BL068NS	1½" NPT swivel inlet x 1¼" NPT without spout
BL072	1½" NPT swivel inlet x 1½" NPT with spout
BL072NS	1½" NPT inlet x 1½" NPT without spout
1143A	1¼" aluminum replacement spout
1125A	1½" aluminum replacement spout

Swivel Nut Pipe Adapters for Ball Nozzles

Nozzle connectors are manufactured from rugged cast bronze. Short body reduces overall length of nozzle. Interchangeable with other manufacturers. For home fuel oil delivery.



SWIVEL NUT PIPE ADAPTERS FOR BALL NOZZLES	
PART NO.	DESCRIPTION
BL002	1¼" male NPT
BL001	1½" male NPT
BL005	fine thread

Note: Some fuel additives are not compatible with certain seal materials. Please contact the Factory for fuel additive compatibility.

K

Trigger Nozzles - MK2

- Sizes:** Standard 1" BSP Pl. inlet
- Materials:** Aluminium body
Nitrile Seals
- Pressure:** Maximum working pressure 60 psi / 4 bar
- Details:** • Ideal for Diesel fuel • For gravity or pumped use



TRIGGER NOZZLE MK 2	
PART NO.	DESCRIPTION
DATN	Basic
DATN/MS	Male Swivel Tail
DATNC/MS	With Trigger Catch
DATN/FS	With Female Swivel Tail
DATNC/FS	With Trigger Catch

Automatic

- Sizes:** Available in 3/4" BSP Pl. Female
- Materials:** Aluminium
- Pressure:** 30 psi / 2 bar minimum working pressure
- Details:** For Diesel dispensing
• Low flow shut down • Robust, quality construction • Simple lever catch
• Automatic flow shut-off



AUTOMATIC NOZZLE	
PART NO.	DESCRIPTION
M3700	Fuel dispensing nozzle

K

Tank Transport Equipment



PIPE CAPS WITH 12" CHAIN AND 'S' HOOK - BSPP THREAD	
ALUMINIUM PART NO.	SIZE
300PCALAP	3"

Tank Transport Equipment - Intermodel



STAINLESS STEEL REDUCERS* FEMALE BSP X MALE BSP	
STAINLESS STEEL* PART NO.	SIZE
3020RDSSAP	3" x 2"

* PTFE gaskets standard

Gaskets & Washers

BUNA-N PART NO.	PTFE PART NO.	NEOPRENE PART NO.	VITON PART NO.	SIZE
-	150GPCTF	-	-	1 1/2"
200GPCBU	200GPCTF	KNW25	KVW25	2"
300GPCBU	300GPCTF	KNW35	KVW35	3"
-	400GPCTF	KNW40	-	4"

Grounding Stud

- Solid brass, stainless steel or aluminium
- With 3/8"-16 UN-3A thread
- For static electric grounding and overfill protection systems

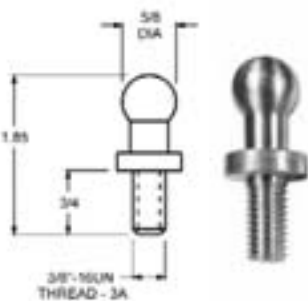

PART NO.	MATERIAL
GS1	Brass
GS2	Stainless Steel

K

FloTech™ Overfill Prevention Products



K

Overfill detection for road tankers is a secondary emergency shut-off system used to prevent overfilling of tanker compartments during the terminal loading process. When an overfill situation is detected, the system will override and shut down the terminal pump/metering equipment filling the tanker compartment(s).

The system consists of overfill sensing devices, which are electronically connected to controls at the terminal through a plug and socket connection. Often on board tanker monitors are employed to inform on the loading process and provide diagnostic data should a problem occur. Monitors also translate electronic signal formats for different operating systems which may exist between the trailer and terminal. The two signal formats used are known as optic and thermistor and are defined by API as Standard #1004. FloTech products specifications for bottom loading and are approved by FM and CSA. Products are manufactured in accordance with EN13922.

Dixon manufactures a full line of sensors, monitors and sockets compatible with Scully and Civacon systems as well as complete overfill kits.

Principals of Operation

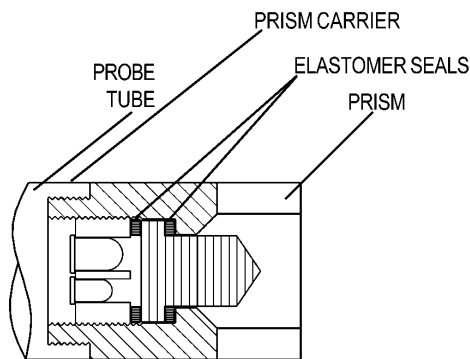

Knowledge and Experienced Design

Dixon employees have vast experience in electronics, manufacturing and most important, with the in-the-field trouble shooting of overfill terminal and tanker installation. That is why we have focused on easy, drop-in replacement features with improved probe life, and why Dixon have included heavy duty hardware made from premium, corrosion resistant materials.

Trouble Free Probes and Sensors:

FloTech brand probes/sensors do not use epoxy bonded prisms as a means to seal the prism. Therefore, they are not subject to malfunction due to epoxy/prism interface separation. FloTech brand probes/sensors

incorporate a double elastomer design which seals and secures the sensitive optic prism tip. The elastomer seals are flexible allowing thermal expansion and resistance to steam cleaning and petroleum chemical attack.

“Best in Class” Technical Support

Dixon provide the most reliable overfill components and systems available on the market today. Over the years the FloTech brand has earned a reputation for reliable overfill components compatible with other common systems. FloTech brand items are shipped with easy to follow installation instructions and manuals.

Easy Installation

FloTech brand components are manufactured to be installed easily, even on other systems. They have been designed to be drop-in compatible with API systems being used around the world.

Products In Stock, Delivered On Time

Dixon realise that downtime costs you money so we do everything we can to ensure you receive your parts when you need them.

A Great Product With An Unparalleled Warranty

FloTech brand products are covered by a three year limited warranty. The warranty is part of the total system that makes FloTech overfill detection the best choice for your operation.

Checkmate Retain Overfill System 2-Wire Black and White

Dixon is proud to introduce Checkmate with advanced automatic self-checking technology and performance enhancing features not found in any other system. The FloTech Checkmate has a long list of features that greatly improve reliability and provide years of trouble free service. Checkmate is compatible with the Scully brand black and white two-wire, overfill and retain system. The components are drop-in replacements and compatible with the signal format required by Scully brand on-board monitors.



FT208 Checkmate Retain / Overfill Monitors

- Easy to follow programming guide for a maximum of eight compartments “top only” or “top and bottom” service with the same monitor
- Monitor can be programmed up to 100,000 times without sending it back to the factory
- Monitor resists oxidation of wire connections
- Stainless steel terminal blocks resist rusting of contacts
- Stainless steel hardware used on all products
- Powder coated colour matched components for exceptional appearance
- Auxiliary input for Hobbs type switches
- Power control relay output
- Drop-in compatibility, see compatibility chart on at the end of this section
- Factory Mutual and Canadian Standards Association approved, ATEX approval pending
- Wide input power 12-24 VDC

K

Tanker, Overfill Prevention & Storage Tank Products

FloTech brand overfill system kits provide everything needed to install a new overfill system on your tank. One through eight compartment kits are available off the shelf. FloTech brand kits provide everything needed to make a professional installation. Systems include; 1 FT208 monitor, 1 FT151 sensor per compartment, 1 FT404 cable and 1 FT402 (20pcs.) strain reliefs. Sockets sold separately.

Special length probes are available. Please refer to comparison chart for cross references to other manufacturer model numbers.

CHECKMATE OVERFILL SYSTEMS (TOP ONLY)



PART NO.	DESCRIPTION
FT2801	Checkmate, 1 compartment system (top only)
FT2802	Checkmate, 2 compartment system (top only)
FT2803	Checkmate, 3 compartment system (top only)
FT2804	Checkmate, 4 compartment system (top only)
FT2805	Checkmate, 5 compartment system (top only)
FT2806	Checkmate, 6 compartment system (top only)
FT2807	Checkmate, 7 compartment system (top only)
FT2808	Checkmate, 8 compartment system (top only)
FT2801-12	Checkmate, 1 compartment system (top only) - 12" probes
FT2802-12	Checkmate, 2 compartment system (top only) - 12" probes
FT2803-12	Checkmate, 3 compartment system (top only) - 12" probes
FT2804-12	Checkmate, 4 compartment system (top only) - 12" probes
FT2805-12	Checkmate, 5 compartment system (top only) - 12" probes
FT2806-12	Checkmate, 6 compartment system (top only) - 12" probes
FT2807-12	Checkmate, 7 compartment system (top only) - 12" probes
FT2808-12	Checkmate, 8 compartment system (top only) - 12" probes

Systems include: 1 FT208 monitor, 1 FT151 overfill and FT152 retain sensor per compartment, 1 FT404-150 cable and 1 FT403 (30 pcs.) strain reliefs. Sockets sold separately.

Special length probes are available. Please refer to comparison chart for cross references to other manufacturer model numbers.

CHECKMATE RETAIN / OVERFILL SYSTEMS (RETAIN AND OVERFILL)



PART NO.	DESCRIPTION
FT2811	Checkmate, 1 compartment system (retain and overfill)
FT2812	Checkmate, 2 compartment system (retain and overfill)
FT2813	Checkmate, 3 compartment system (retain and overfill)
FT2814	Checkmate, 4 compartment system (retain and overfill)
FT2815	Checkmate, 5 compartment system (retain and overfill)
FT2816	Checkmate, 6 compartment system (retain and overfill)
FT2817	Checkmate, 7 compartment system (retain and overfill)
FT2818	Checkmate, 8 compartment system (retain and overfill)
FT2811-12	Checkmate, 1 compartment system (retain and overfill) - 12" probes
FT2812-12	Checkmate, 2 compartment system (retain and overfill) - 12" probes
FT2813-12	Checkmate, 3 compartment system (retain and overfill) - 12" probes
FT2814-12	Checkmate, 4 compartment system (retain and overfill) - 12" probes
FT2815-12	Checkmate, 5 compartment system (retain and overfill) - 12" probes
FT2816-12	Checkmate, 6 compartment system (retain and overfill) - 12" probes
FT2817-12	Checkmate, 7 compartment system (retain and overfill) - 12" probes
FT2818-12	Checkmate, 8 compartment system (retain and overfill) - 12" probes

K

Checkmate Retain Overfill System 2-Wire Black and White

The FT150 thermo-optic 2 wire probe is electronically and mechanically compatible for drop-in replacement of commonly used 2-wire probes with black and white wires. The FT150 provides the fast response and reliability of optic technology in a thermistor application. All FloTech brand probes come with a unique dual elastomer seal for prisms and a smooth tapered tip design for easy installation without gasket damage. Custom lengths available upon request. Compatible with the Scully Intellicheck system (probe housing is part # FT90001)



FT150 REPLACEMENT BLACK AND WHITE 2-WIRE PROBES

PART NO.	DESCRIPTION
FT150	Replacement probe, thermo-optic, 2 wire (black and white), 7"
FT150-12	Replacement probe, thermo-optic, 2 wire (black and white), 12"
FT150-18	Replacement probe, thermo-optic, 2 wire (black and white), 18"
FT155	Dummy



The FT151 thermo-optic sensor contains the FT150 probe and a 2" NPT housing. Our probe holder is cast aluminium with a 2" NPT mounting thread, heavy duty stainless steel hardware, and Viton® probe seal. Install in a 2" NPT female thread or 2³/₈" hole using the gasket and locking nut provided. All screws and rings are heavy duty stainless steel for easy assembly and long life. Compatible with Scully Intellicheck monitors (probe housing is part # FT9000)

FT151 THERMO-OPTIC SENSORS

PART NO.	DESCRIPTION
FT151 - ATEX	Sensor, thermo-optic, 2 wire (black and white), 2" NPT housing with 7" probe
FT151-12 - ATEX	Sensor, thermo-optic, 2 wire (black and white), 2" NPT housing with 12" probe
FT151-18 - ATEX	Sensor, thermo-optic, 2 wire (black and white), 2" NPT housing with 18" probe



The FT152 retain sensor is a bottom retain detection sensor. The sensor has a 1/2" NPT mounting. Sensor is shipped with a 1/2" NPT weld-on aluminium half coupling for mounting. The main sensor portion is stainless steel to prevent galling in the trailer. The wiring box is plastic to prevent corrosion and is removable to facilitate installation. The side ports come out of the same side (like the overfill sensors) to make wiring easier. The FT152 is mechanically and electrically compatible with Scully model 08819 and the Scully Intellicheck System.

FT152 RETAIN SENSOR

PART NO.	DESCRIPTION
FT152 - ATEX	Replacement Scully retain sensor, 2 wire (black and white)

K

The FT208 Checkmate is compatible with the Scully brand black and white two-wire thermo-optic (thermistor) overfill and retain system. Components are drop-in replacement and compatible with the signal format required by the Scully Intellicheck brand on-board monitors. Easy to follow programming guide for a maximum of eight compartments, programmable for number of compartments, top only, top and bottom service with the same monitor.



FT208 CHECKMATE RETAIN / OVERFILL MONITOR

PART NO.	DESCRIPTION
FT208	Checkmate monitor, programmable for top only, or top and bottom sensors, with housing
FT207	Checkmate replacement monitor module

R/OM Type Retain/Overfill System Red & Black 2 Wire

These systems incorporate the preferred optic technology (red and black 2 wire) using top overfill as well as bottom retain sensors. Retain sensors inform the terminal if the compartments are empty or if product has been retained. Monitors include advanced diagnostic capabilities as well as translation abilities for all socket types (optic, thermistor or float). The system offers true load at any rack compatibility.

FloTech brand overfill system kits provide everything needed to install a new API compatible overfill system on your tank. One through six compartment kits are available off the shelf. Systems include: 1 FT204P monitor, 1 FT202 sensor per compartment, 1 FT401 100' cable and 1 FT402 (20 pcs.) strain reliefs. Sockets sold separately. Special length probes are available. Please refer to comparison chart for cross references to other manufacturer model numbers.



ROM OVERFILL SYSTEM (TOP ONLY)

PART NO.	DESCRIPTION
FT2101	R/OM type, 1 compartment system (top only)
FT2102	R/OM type, 2 compartment system (top only)
FT2103	R/OM type, 3 compartment system (top only)
FT2104	R/OM type, 4 compartment system (top only)
FT2105	R/OM type, 5 compartment system (top only)
FT2106	R/OM type, 6 compartment system (top only)
FT2101-12	R/OM type, 1 compartment system (top only) - 12" probes
FT2102-12	R/OM type, 2 compartment system (top only) - 12" probes
FT2103-12	R/OM type, 3 compartment system (top only) - 12" probes
FT2104-12	R/OM type, 4 compartment system (top only) - 12" probes
FT2105-12	R/OM type, 5 compartment system (top only) - 12" probes
FT2106-12	R/OM type, 6 compartment system (top only) - 12" probes

FloTech brand overfill system kits provide everything needed to install a new API compatible retain/ overfill monitor top and bottom system. One through six compartment kits are available off the shelf. Systems include: 1 FT204P monitor, 1 FT202 sensor for each compartment, 1 FT206 retain sensor per compartment, 1 FT401 100' cable and 1 FT402 (20 pcs.) strain reliefs. Sockets sold separately. Special length probes are available. Please refer to comparison chart for cross references to other manufacturer model numbers.

K



ROM RETAIN / OVERFILL SYSTEMS (RETAIN AND OVERFILL)

PART NO.	DESCRIPTION
FT2001	R/OM type, 1 compartment system (retain and overfill)
FT2002	R/OM type, 2 compartment system (retain and overfill)
FT2003	R/OM type, 3 compartment system (retain and overfill)
FT2004	R/OM type, 4 compartment system (retain and overfill)
FT2005	R/OM type, 5 compartment system (retain and overfill)
FT2006	R/OM type, 6 compartment system (retain and overfill)
FT2001-12	R/OM type, 1 compartment system (retain and overfill) - 12" probes
FT2002-12	R/OM type, 2 compartment system (retain and overfill) - 12" probes
FT2003-12	R/OM type, 3 compartment system (retain and overfill) - 12" probes
FT2004-12	R/OM type, 4 compartment system (retain and overfill) - 12" probes
FT2005-12	R/OM type, 5 compartment system (retain and overfill) - 12" probes
FT2006-12	R/OM type, 6 compartment system (retain and overfill) - 12" probes

Tanker, Overfill Prevention & Storage Tank Products



The FT201 is a replacement probe for the FloTech brand FT202 sensor and is compatible with Civacon's 3150 two wire optic probe. The FloTech brand FT200 series probe uses our unique dual elastomer seal prism design to prevent fouling. Other sensor designs use epoxy which crack allowing fuel to leak into the optic path ultimately causing signal malfunction. Custom lengths available upon request (probe housing is part # FT9000).

FT201 REPLACEMENT PROBES

PART NO.	DESCRIPTION
FT201	Replacement R/OM type, 2 wire (red and black) top probe, 7"
FT201-12	Replacement R/OM type, 2 wire (red and black) top probe, 12"
FT201-18	Replacement R/OM type, 2 wire (red and black) top probe, 18"



The FT202 sensor is a top overfill sensor and part of the FloTech brand retain/overfill monitoring system. The probe holder is cast aluminium with a 2" NPT mounting thread, heavy duty stainless steel hardware, and Viton® seals. The FT202 is mechanically and electrically compatible with the Civacon model 1050 two wire top sensor. The sensor is installed by threading it into a 2" NPT female thread or mounting it in a 2³/₈" hole secured by a gasket and metal locking nut. (probe housing is part # FT9000).

FT202 THERMO-OPTIC SENSORS

PART NO.	DESCRIPTION
FT202 - ATEX	Sensor R/OM type (red and black), top with 2" NPT housing, with 7" probe
FT202-12 - ATEX	Sensor R/OM type (red and black), top with 2" NPT housing, with 12" probe
FT202-18 - ATEX	Sensor R/OM type (red and black), top with 2" NPT housing, with 18" probe



The FT206 retain sensor is a bottom retain detection sensor and part of the FloTech brand retain/ overfill monitoring system. The sensor has a 1/2" NPT mounting. Sensor comes with a 1/2" NPT weld-on aluminium half coupling for mounting. The main sensor portion is stainless steel to prevent galling in the trailer. The wiring box is plastic to prevent corrosion and is removable to facilitate installation. The side ports come out of the same side (like the overfill sensors) to make wiring easier. The FT206 is mechanically and electrically compatible with the Civacon model 1000 two wire retain sensor.

FT206 RETAIN SENSOR

PART NO.	DESCRIPTION
FT206 - ATEX	Retain sensor R/OM type (red and black), 1/2" NPT sensor

K



The FT204P retain/overfill monitor is designed to diagnose and monitor up to six compartments. The FT204P monitor will provide API compatible optic, thermistor, and float socket outputs for a true load at any rack compatibility. FloTech's FT203P is a replacement chassis and is compatible with Civacon 3250 and 3252 onboard monitors.

FT204P RETAIN / OVERFILL MONITOR

PART NO.	DESCRIPTION
FT204P	R/OM type onboard monitor, with housing
FT203P	Replacement chassis, R/OM type on-board

API Optic System 5-Wire

FloTech series FT100 and FT101 sensors are compatible with Scully brand 5 wire optic sensors. FloTech API compatible overfill systems feature long service life and resistance to harsh environments typical on petroleum cargo tanks. Long service life and compatibility make FloTech™ the ideal choice for demanding cargo applications.

FloTech brand overfill system kits provide everything needed to install a new API compatible overfill system on your tank. One through six compartment kits are available off the shelf. Systems include: 1 FT103 monitor, 1 FT101 sensor per compartment, 1 FT400 100' cable and 1 FT402 (20 pcs.) strain reliefs. Sockets sold separately.



OPTIC OVERFILL KITS

PART NO.	DESCRIPTION
FT1001	API compatible 1 compartment system (optic)
FT1002	API compatible 2 compartment system (optic)
FT1003	API compatible 3 compartment system (optic)
FT1004	API compatible 4 compartment system (optic)
FT1005	API compatible 5 compartment system (optic)
FT1006	API compatible 6 compartment system (optic)
FT1001-12	API compatible 1 compartment system (optic) - 12" probe
FT1002-12	API compatible 2 compartment system (optic) - 12" probe
FT1003-12	API compatible 3 compartment system (optic) - 12" probe
FT1004-12	API compatible 4 compartment system (optic) - 12" probe
FT1005-12	API compatible 5 compartment system (optic) - 12" probe
FT1006-12	API compatible 6 compartment system (optic) - 12" probe



The FT100 replacement probe is electronically and mechanically compatible with the API optic or 5 wire signal format. The FT100 sensor features a dual prism seal design which is more reliable than other designs which glue in the prism using epoxies. Custom lengths are available upon request. The FT100 is compatible with Scully #09208 and Civacon #1300. (probe housing is part # FT9000).

FT100 REPLACEMENT PROBE

PART NO.	DESCRIPTION
FT100	5 wire API optic probe, 7"
FT100-12	5 wire API optic probe, 12"
FT100-18	5 wire API optic probe, 18"



The FT101 sensor is compatible with the API optic or 5 wire signal format. Our probe holder is cast aluminium with a 2" NPT mounting thread, heavy duty stainless steel hardware, and Viton® seals. Install in a 2" NPT female thread or 23/8" hole using the provided gasket and locking nut. (probe housing is part # FT9000).

FT101 SENSORS

PART NO.	DESCRIPTION
FT101 - ATEX	Sensor, optic, 5 wire, 2" NPT housing with 7" probe
FT101-12 - ATEX	Sensor, optic, 5 wire, 2" NPT housing with 12" probe
FT101-18 - ATEX	Sensor, optic, 5 wire, 2" NPT housing with 18" probe

The FT103 API compatible monitor works with the FloTech API compatible sensor models FT101/ 100. This six channel monitor will provide API compatible optic, thermistor, and float socket outputs for a true load at any rack compatibility. Entity approved by CSA and FM to ensure safety. The FT102 replacement chassis is compatible with Civacon 3150 or Scully 08563 on-board monitors.



FT103 API COMPATIBLE MONITOR

PART NO.	DESCRIPTION
FT103	API compatible on-board monitor, with housing
FT102	Replacement chassis, API compatible

Tanker, Overfill Prevention & Storage Tank Products

Dummies send a permissive signal for any missing compartments. For example, in the United States all overfill systems are formatted assuming a six compartment thermistor trailer. Therefore, the terminal controller must receive six permissive sensor signals to allow loading. One dummy can send up to five signals. Consequently a one to five compartment trailer will contain one FT155 dummy (wired to socket). In Canada, where eight channel systems are mandated, two FT155 dummies are needed with one to three compartment trailers and one FT155 for four to seven compartments. The FloTech FT155 thermistor dummy provides instant permissive signal in the coldest weather and is mechanically and electrically compatible with Scully and Civacon models.



FT155 DUMMY

PART NO.	DESCRIPTION
FT155	Thermistor dummy, 5 compartment

When using the FloTech trailer mounted ground ball the trailer cannot be loaded unless the terminal ground is directly connected to the ground ball.



GROUNDING BALL

PART NO.	DESCRIPTION
FT451	Stainless steel grounding ball

Cables are colour matched to commonly used overfill systems and have a tough, thick outer jacket resistant to oil, UV and abrasion. For watertight cable/sensor connections apply FloTech brand strain/relief sealing glands. Two packages are available: FT402 - 20 pieces for typical top only sensor connection systems or; FT403 - 30 pieces for typical top and bottom sensor connection systems.



CABLES AND GLANDS

PART NO.	DESCRIPTION
FT400	5 conductor cable 100'
FT400-1000	5 conductor cable 1000 FT reel
FT401	7 conductor cable 100'
FT401-150	7 conductor cable 150'
FT401-1000	7 conductor cable 1000 FT reel
FT404	11 conductor cable 100'
FT404-150	11 conductor cable 150'
FT404-1000	11 conductor cable 1000' reel
FT402	Strain relief fittings, 1/2 NPT, 1 box = 20 pcs.
FT403	Strain relief fittings, 1/2 NPT, 1 box = 30 pcs.
FT405-500	Strain relief fittings, 1/2 NPT, 500 piece box

The FT520 optic test kit includes a Go, No/Go tester and test lead sets to test five wire optic probes, two wire optic probes, and on-board monitor socket outputs. It uses the same permissive signal verification as an optic rack monitor. Optional FT521, FT522, FT523 optic test plugs are available for an entire trailer Go, No/Go test.



OPTIC SYSTEM TESTER

PART NO.	DESCRIPTION
FT520	Optic system tester
FT520CASE	Case only for FT520
FT520WOGA	Optic system tester with FT521 test plug no test leads
FT520WOGACASE	Optional case for FT520 WOGA
FT521	API optic test plug with six pins and three J-slots
FT522	Optic test plug with six pins and two or four J-slots
FT523	Optic test plug J-560 type
FT524	Thermistor socket test plug (US)
FT524-8	Thermistor socket test plug (Canada)

Sockets

Sockets allow the transfer of the electronic signal from the terminal control monitor to the tanker and return. Sockets will vary depending upon terminal equipment and regional regulations. Dixon offer a full line of sockets for all requirements. FloTech brand sockets are mechanically and electronically compatible with the API RP1004 Rel. 2003 Bottom Loading Specification. Optic and thermistor socket face plates are hard coated aluminium alloy to prevent J-slot wear. All hardware and contact buttons are stainless steel to prevent corrosion. FloTech brand sockets are standard colour coded to permit easy identification (optic sockets are blue, thermistors are green, and float are red). Coloured caps are included for optic and thermistor models. All sockets now incorporate the patented removable nose ring.



FT300 Optic Socket



FT301 Thermistor Socket



FT302 Float Socket

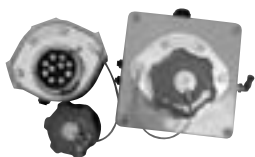

Overfill Prevention Sockets

ALUMINIUM HARDCOAT J-SLOT WEAR RING

PART NO.	DESCRIPTION
FT300	Optic socket API / WOGA, 6 pin and 3 J-slots
FT301	Thermistor socket, API, 8 pin and 4 J-slots
FT302	Float, API, J560 pin type socket
FT303	Optic socket, 6 pin and 4 J-slots (U.S.)
FT304	Thermistor socket, 10 pin and 4 J-slots (Canada, Europe)
FT305	Thermistor socket, J560 pin type
FT306	Optic socket, J560 pin type
FT307	Optic socket, 6 pin and 4 J-slots (Canada)
FT3010	API optic face plate assembly, 6 pin, 3-J slots
FT3011	API thermistor face plate assembly, 8 pin, 4-J slots
FT3013	Optic pattern contact assembly with thermistor, 6 pin, 4-J slots
FT3014	Thermistor face plate assembly (Canada/Europe), 10 pin 4-J slots
FT3015	Thermistor replacement face plate, J560 type
FT3016	Optic replacement face plate, J560 type
FT3017	Optic pattern face plate assembly (Canada), 6 pin, 4-J slots
FT3020	Blue optic dust cap
FT3021	Green thermistor dust cap
FT304BI	Socket with brake interlock
FT304VI	Socket with vapour recovery interlock
FT304BVI	Socket with both brake interlock and vapour recovery interlock

Dixon offer a complete range of replacement parts for your overfill systems.

GFL series stainless steel nose rings are now available on any configuration socket that you require. The Dixon stainless steel J-slots outlast competitor versions because they are tougher and more corrosion resistant than any other on the market. *GFL socket J-slots are so tough that they are "Guaranteed for Life" against wear. U.S. patent 6,824,423.

K

GFL (GUARANTEED FOR LIFE*) SERIES STAINLESS STEEL J-SLOT WEAR RING

PART NO.	DESCRIPTION
FT300SS	Optic socket API / WOGA, 6 pin and 3 J-slots GFL stainless wear ring
FT301SS	Thermistor socket, API, 8 pin and 4 J-slots GFL stainless wear ring
FT303SS	Optic socket, 6 pin and 4 J-slots (U.S.) GFL stainless wear ring
FT304SS	Thermistor socket, 10 pin and 4 J-slots (Canada, Europe) GFL stain.wear ring
FT307SS	Optic socket, 6 pin and 4 J-slots (Canada) GFL stainless wear ring
FT310SS	API optic face plate assembly, 6 pin, 3 J-slots GFL stainless wear ring
FT311SS	API thermistor face plate assembly, 8 pin, 4 J-slots GFL stainless wear ring
FT313SS	Optic pattern face plate assembly with thermistor, 6 pin, 4-J slots GFL stainless wear ring
FT314SS	Thermistor face plate assembly (Canada/Europe), 10 pin, 4-J slots GFL stainless wear ring
FT317SS	Optic pattern face plate assembly (Canada), 6 pin, 4 J-slots GFL stainless wear ring



API Compatible Rack Cords

- FT600 and FT620 are compatible with API thermistor and optic configurations
- Cord available in coiled or straight lengths
- Cord features a heavy highly visible safety orange jacket to meet trip hazard requirements
- Cord is bonded mechanically and has superior abrasion and oil resistance
- Cord sets are interchangeable with Scully and Civacon, please refer to pages 380-381 for the cross reference chart
- Plug body is machined from 6061 aluminum and is color coded optic blue or thermistor green
- Button contacts are made from 316 stainless steel to prevent corrosion or galling
- All other hardware is stainless steel
- All wiring is compatible with standard Scully color codes and wiring number configurations
- The 9 pin conductor is shielded to be compatible with Scully VIP system



MODEL FT620 API OPTIC ASSEMBLIES

PART NO.	SCULLY PART NO.	CIVACON PART NO.	DESCRIPTION
FT620	21831	7120SR	plug with 30' coiled cable
FT620S	-	-	plug with 20' straight cable
FT621	21766	7110	replacement plug body
FT622	27211	-	replacement 30' coiled cable
FT623	08235	-	plug hanger

MODEL FT600 API THERMISTOR ASSEMBLIES

PART NO.	SCULLY PART NO.	CIVACON PART NO.	DESCRIPTION
FT600	21818	7320	plug with 30' coiled cable
FT600C	-	-	API thermistor plug and 30' coiled cord set (Canada)
FT600S	-	-	plug with 20' straight cable
FT600SC	-	-	plug with 20' straight cord set (Canada)
FT601	20769	7310	replacement plug body
FT601-10	08959	-	replacement plug, 10 pin (Canada)
FT602	27211	-	replacement 30' coiled cable
FT603	-	-	plug hanger
FT604	-	-	replacement 20' straight cord

K

Tanker, Overfill Prevention & Storage Tank Products

Comparison Reference Chart

Listed is a cross reference between FloTech brand "Drop In" replacement parts and competitor products.

REPLACEMENT PARTS & COMPETITOR PRODUCTS				
LIQUID LEVEL SENSORS	FLOTECH PART NO.	CIVACON PART NO.	SCULLY PART NO.	DESCRIPTION
	FT100	1300	09209	Replacement probe, optic, 5-wire, 7" long
	FT100-12	13008	09214	Replacement probe, optic, 5-wire, 12" long
	FT101	1110	09208	Sensor, optic, 5-wire, 2" NPT housing, 7" probe
	FT101-12	11108	09213	Sensor, optic, 5-wire, 2" NPT housing with 12" probe
	FT150	1650	09409	Replacement probe, thermo-optic, 7" long, 2-wire (black & white)
	FT150-12	16508	09414	Replacement probe, thermo-optic, 12" long, 2-wire (black & white)
	FT151	1550	09408	Sensor, thermo-optic, 2" NPT housing, 7" probe, 2-wire (black & white)
	F151-12	15508	09413	Sensor, thermo-optic, 2" NPT housing, 12" probe, 2-wire (black & white)
	FT152	-	08810	Retain sensor
	FT155	1900	08542	Thermistor dummy, 5 compartment
	FT201	1350	-	Replacement R/OM type, 7" top probe, 2-wire (red & black)
	FT201-12	13508	-	Replacement R/OM type, 12" top probe, 2-wire (red & black)
	FT202	1050	-	Top sensor R/OM type, 2" NPT housing, 7" probe, 2-wire (red & black)
	FT202-12	-	-	Top sensor R/OM type, 2" NPT housing, 12" probe, 2-wire (red & black)
	FT205	1910	-	Terminator
FT206	1000	-	Retain sensor R/OM type, 2" NPT sensor (red & black)	
ON BOARD MONITORS	FLOTECH PART NO.	CIVACON PART NO.	SCULLY PART NO.	DESCRIPTION
	FT102	3150	08563	Replacement chassis, API compatible
	FT103	3100	88687	API compatible on-board monitor, with housing
	FT203P	3252	-	Replacement chassis, R/OM type on-board monitor
	FT204P	3202	-	R/OM type on-board monitor, with housing
	FT207	-	09100/09111	Replacement module, Checkmate on-board monitor
	FT208	-	09109.09107	Checkmate programmable monitor for top, or top and bottom sensors
SOCKETS	FLOTECH PART NO.	CIVACON PART NO.	SCULLY PART NO.	DESCRIPTION
	FT300	4100	07974	API compatible optic socket with cap (6 pin, 3 J-slots)
	FT301	4400	07720	API compatible thermistor socket with cap (8 pin, 2/4 J-slots)
	FT302	4600	08116	API compatible float socket
	FT303	4200	07976	Optic pattern with thermistor J-slots, and cap (6 pin, 2/4 J-slots)
	FT304	4401	07716	Canadian / European thermistor socket with cap (10 pin, 4 J-slots)
	FT305	4500	07681	Thermistor socket, J560 type
	FT306	4300	08199	Optic socket, J560 type
	FT310	4110	21790	API optic face plate assembly with cap
	FT311	4410	20770	API thermistor face plate assembly with cap
	FT314	-	20768	Canadian / European thermistor replacement face plate with cap
	FT320	4150	08575	Blue optic dust cap
	FT321	4450	08574	Green thermistor dust cap
	FT390	-	09060	EZ-Cept dual socket assembly
	FT304BI	-	08646I	Socket with brake interlock
	FT304VI	4401B	08646P	Socket with vapour recovery interlock
	FT304BVI	4401E-SQS	08646IP	Socket with both brake interlock and vapour recovery interlock
HARDWARE SYSTEM TESTERS	FLOTECH PART NO.	CIVACON PART NO.	SCULLY PART NO.	DESCRIPTION
	FT400	2100	22056	5 conductor cable 100'
	FT401	2310	27382	7 conductor cable 100'
	FT402	2510	-	20 strain relief fittings, 1/2 NPT
	FT403	-	-	30 strain relief fittings, 1/2 NPT
	FT520	-	-	Optic system tester
	FT530	-	-	T.I.M. reader

Civacon and R/OM are registered trademarks of Civacon/Dover Corp. Intellicheck is a registered trademark of Scully Signal Co.

K

Comparison Reference Chart (continued)

Listed is a cross reference between FloTech brand "Drop In" replacement parts and competitor products.

REPLACEMENT PARTS & COMPETITOR PRODUCTS				
ON BOARD SYSTEMS	FLOTECH PART NO.	CIVACON PART NO.	SCULLY PART NO.	DESCRIPTION
	FT1004	2004	08305	API compatible 4 compartment system
	FT1005	2005	08306	API compatible 5 compartment system
	FT2004	3024	-	R/OM type, 4 compartment system
	FT2005	3025	-	R/OM type, 5 compartment system
	FT2104	3034	-	R/OM type, 4 compartment system (top only)
	FT2105	3035	-	R/OM type, 5 compartment system (top only)
	FT2801	-	08251	Checkmate system, one compartment, top only
	FT2802	-	08352	Checkmate system, two compartment, top only
	FT2803	-	08353	Checkmate system, three compartment, top only
	FT2804	-	08354	Checkmate system, four compartment, top only
	FT2805	-	08355	Checkmate system, five compartment, top only
	FT2806	-	08356	Checkmate system, six compartment, top only
	FT2807	-	08380	Checkmate system, seven compartment, top only
	FT2808	-	08381	Checkmate system, eight compartment, top only
	FT2811	-	08361	Checkmate system, one compartment, top and bottom sensors
	FT2812	-	08362	Checkmate system, two compartment, top and bottom sensors
	FT2813	-	08363	Checkmate system, three compartment, top and bottom sensors
	FT2814	-	08364	Checkmate system, four compartment, top and bottom sensors
	FT2815	-	08365	Checkmate system, five compartment, top and bottom sensors
	FT2816	-	08366	Checkmate system, six compartment, top and bottom sensors
	FT2817	-	08382	Checkmate system, seven compartment, top and bottom sensors
	FT2818	-	08383	Checkmate system, eight compartment, top and bottom sensors

Civacon and R/OM are registered trademarks of Civacon/Dover Corp. Intellicheck is a registered trademark of Scully Signal Co.

Dixon Valve and Coupling Company warrants the FloTech products described herein, and manufactured by Dixon to be free from defects in material and workmanship for a period of three (3) years from date of shipment by Dixon under normal use and service.

For further warranty information see page 509.

V-Ring Swivel Joints

- | | |
|---------------------------|------------------------|
| 1. Body | 6. Spring retainer |
| 2. Sleeve | 7. Spring |
| 3. Ball bearings | 8. Ball retainer screw |
| 4. Seal retainer | 9. Grease fitting |
| 5. V-Ring (pressure) seal | 10. O-Ring (dust) seal |

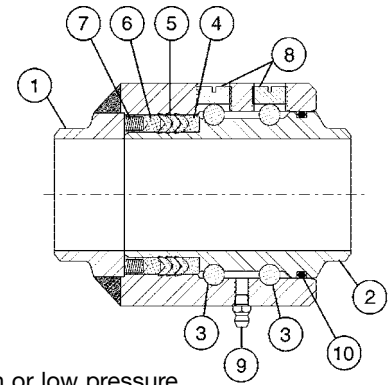

V-Ring Features

- The spring-loaded triple V-ring sealing system ensures a leak proof seal at either high or low pressure and an extended seal life compared to the conventional single O-ring design
- The 3" - 8" carbon steel swivels are manufactured from a special grade of carbon steel with flame hardened dual raceways for greater load bearing capacity and longer life
- The stainless steel swivels are manufactured in 316 grade stainless steel for superior corrosion resistance.
- Available with pressure ratings to 1,000 psi
- Available in carbon steel, stainless steel and aluminum

Single Plane V-Ring Style 20

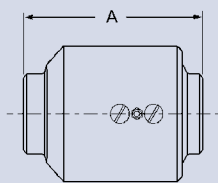

weld end x weld end
sizes 2" - 8"

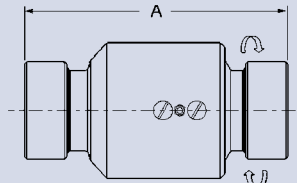

female NPT x female NPT
sizes 2" - 8"

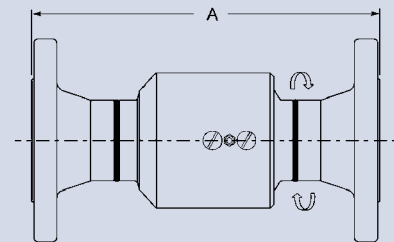

150# ASA f angle x 150# ASA f angle
sizes 2" - 8"

Single Plane V-Ring Style 30

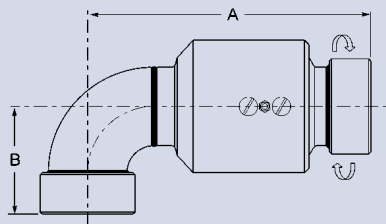

female NPT x female NPT
sizes 2" - 8"

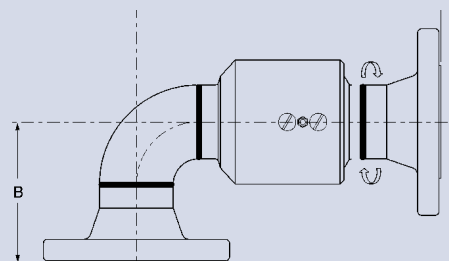

150# ASA f angle x 150# ASA f angle
sizes 2" - 8"

Single Plane V-Ring Style 40

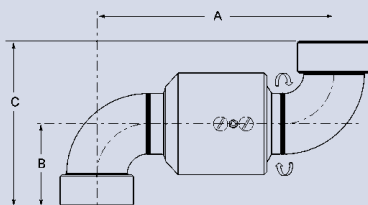

female NPT x female NPT
sizes 2" - 8"

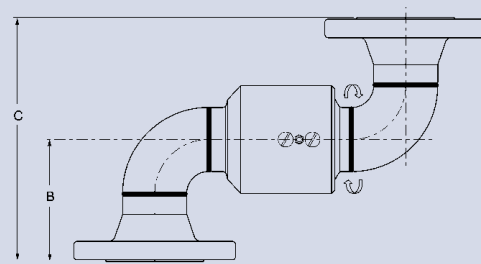

150# ASA f angle x 150# ASA f angle
sizes 2" - 8"

K

Tanker, Overfill Prevention & Storage Tank Products

Double Plane V-Ring Style 50

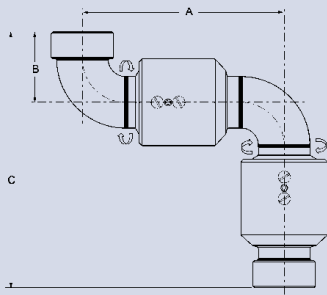

female NPT x female NPT
sizes 2" - 8"

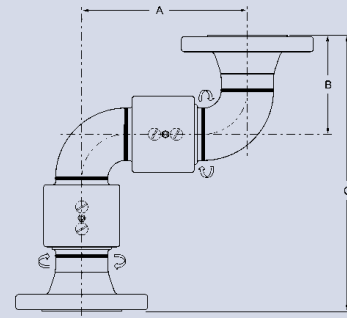

150# ASA f ange x 150# ASA f ange
sizes 2" - 8"

Double Plane V-Ring Style 60

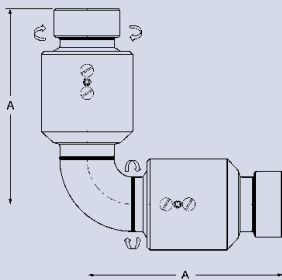

female NPT x female NPT
sizes 2" - 8"

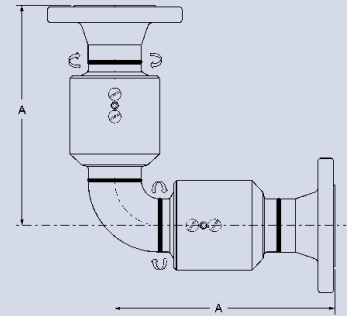

150# ASA f ange x 150# ASA f ange
sizes 2" - 8"

Double Plane V-Ring Style 70

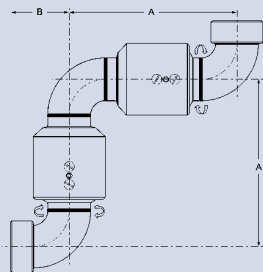

female NPT x female NPT
sizes 2" - 8"

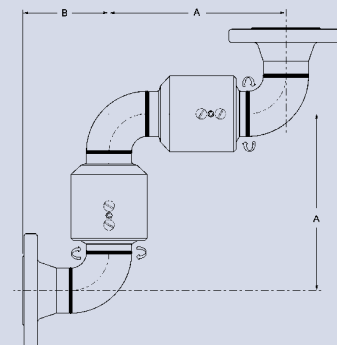

150# ASA f ange x 150# ASA f ange
sizes 2" - 8"

Triple Plane V-Ring Style 80

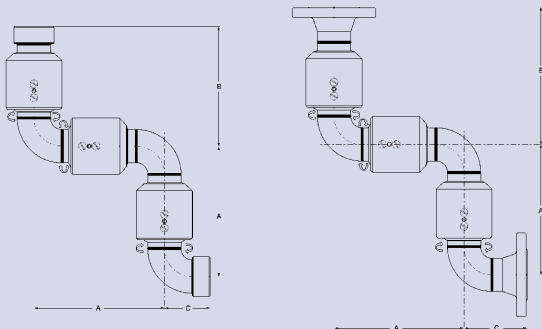

female NPT x female NPT
sizes 2" - 8"

150# ASA f ange x 150# ASA f ange
sizes 2" - 8"

Triple Plane V-Ring Style 10

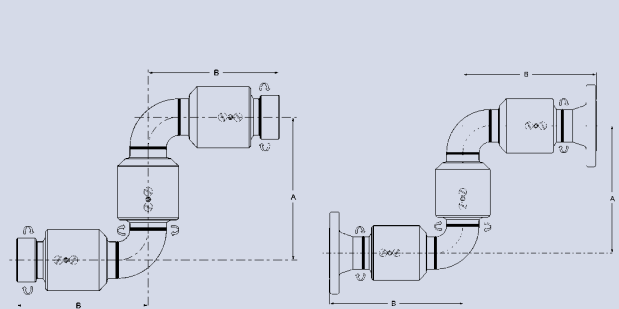

female NPT x female NPT
sizes 2" - 8"

150# ASA f ange x 150# ASA f ange
sizes 2" - 8"

Typical Applications for V-Ring Swivels

Loading Arms

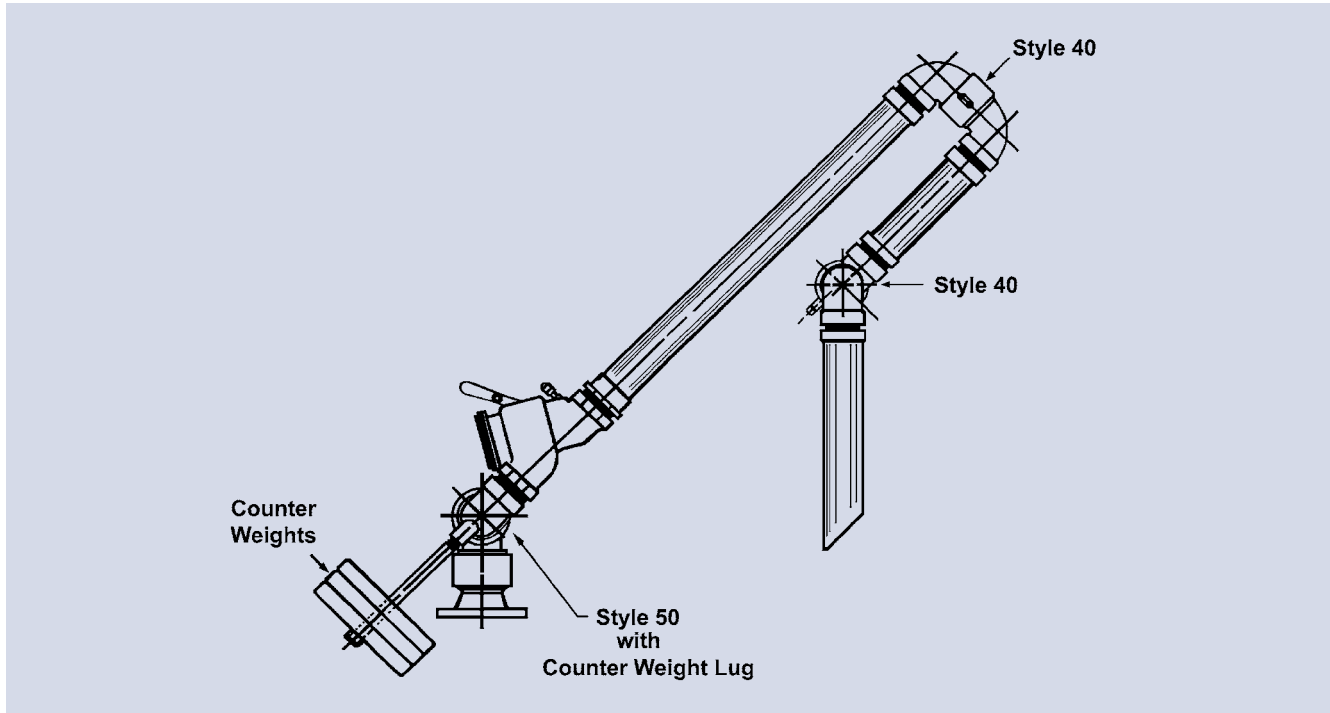

Floating Roof Drains

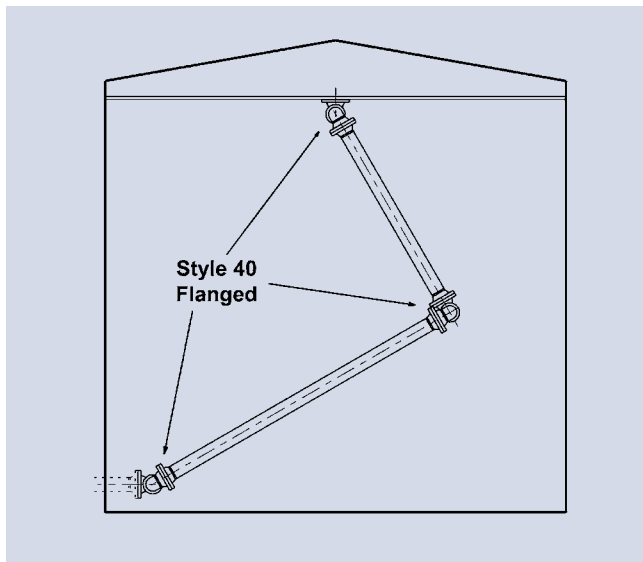

Floating Suction

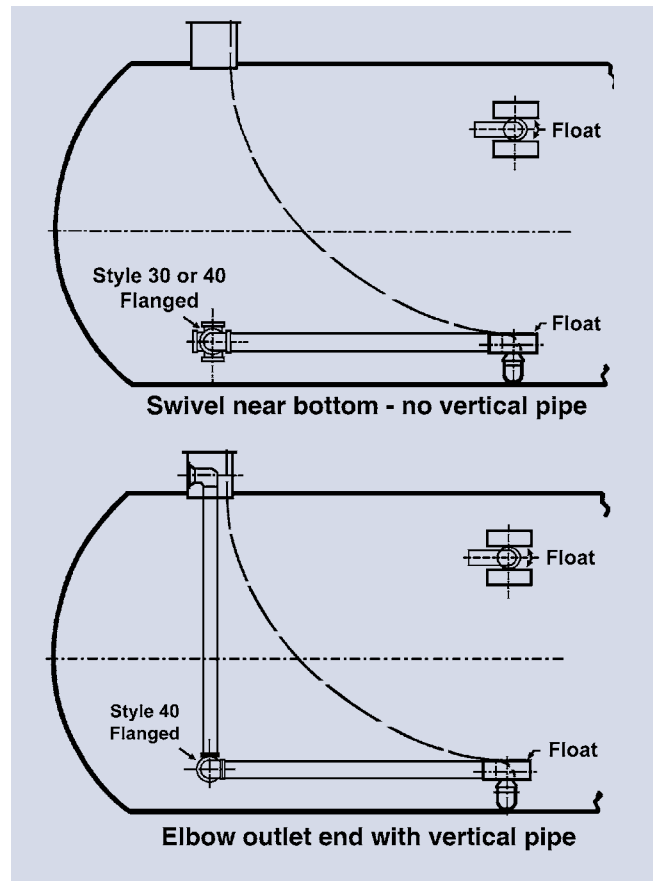

K

O-Ring Swivel Joints

1. O-Ring (dust) seal
2. Ball retainer screw
3. O-Ring (pressure) seal
4. Grease fitting
5. Ball bearings

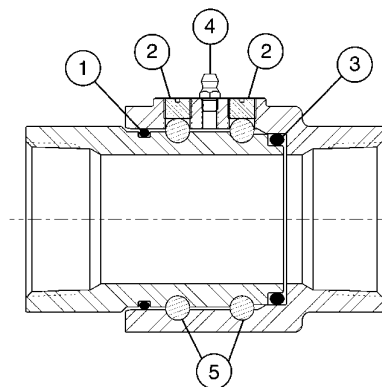

O-Ring Features

- The O-ring pressure seal ensures a leak-proof seal at either high or low pressure and smoother rotation at lower torque than multiple seal designs
- Spring-loaded PTFE pressure seals are available up through 3"
- Carbon steel and stainless steel O-ring type swivels provide greater strength and corrosion resistance when needed for lower torque applications
- Available in carbon steel, stainless steel, aluminum, brass and iron

Single Plane O-Ring Style 20

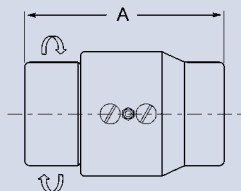

female NPT x female NPT
sizes 1" - 4"

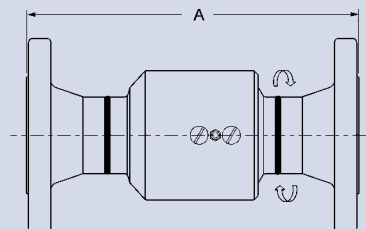

150# ASA f ange x 150# ASA f ange
sizes 1" - 4"

Single Plane O-Ring Style 30

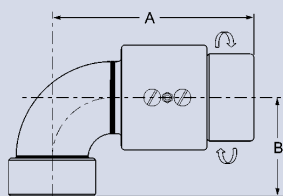

female NPT x female NPT
sizes 1" - 4"

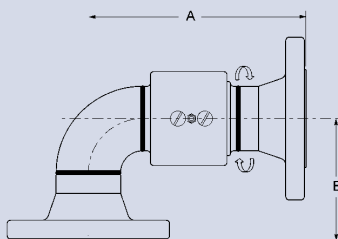

150# ASA f ange x 150# ASA f ange
sizes 1" - 4"

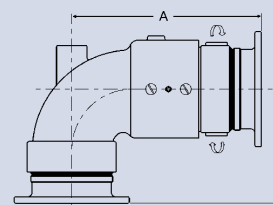

tank truck f ange x tank truck f ange
sizes 2" - 4"

Single Plane O-Ring Style 40

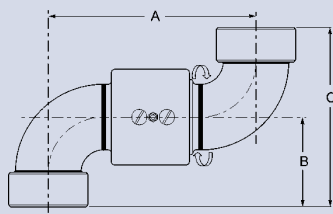

female NPT x female NPT
sizes 1" - 4"

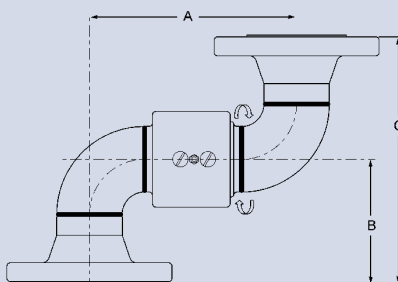

150# ASA f ange x 150# ASA f ange
sizes 1" - 4"

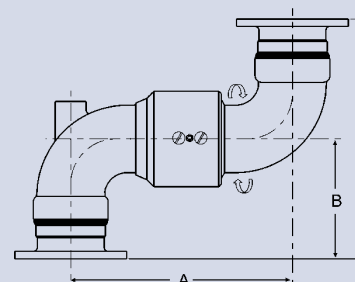

tank truck f ange x tank truck f ange
sizes 2" - 4"

Tanker, Overfill Prevention & Storage Tank Products

Double Plane O-Ring Style 50

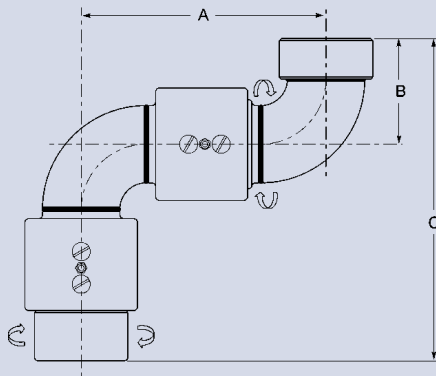

female NPT x female NPT
sizes 1" - 4"

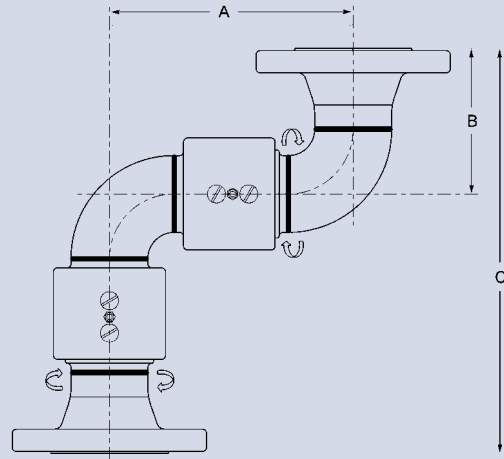

150# ASA f ange x 150# ASA f ange
sizes 1" - 4"

Double Plane O-Ring Style 60

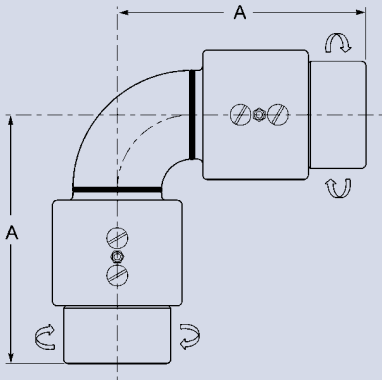

female NPT x female NPT
sizes 1" - 4"

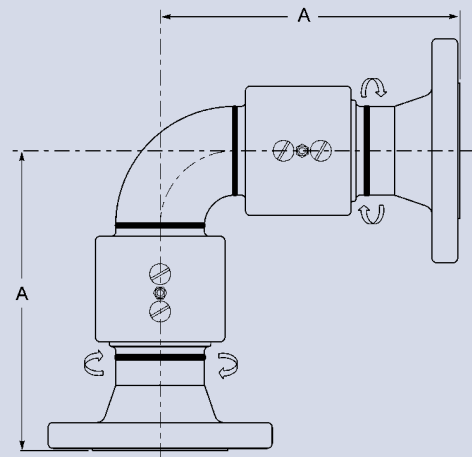

150# ASA f ange x 150# ASA f ange
sizes 1" - 4"

Triple Plane O-Ring Style 70

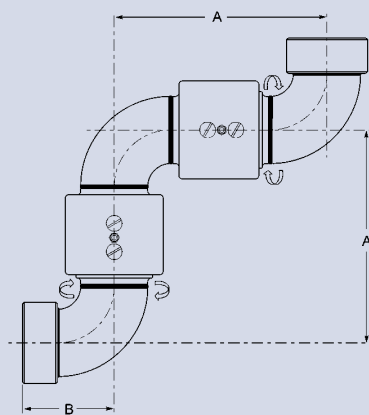

female NPT x female NPT
sizes 1" - 4"

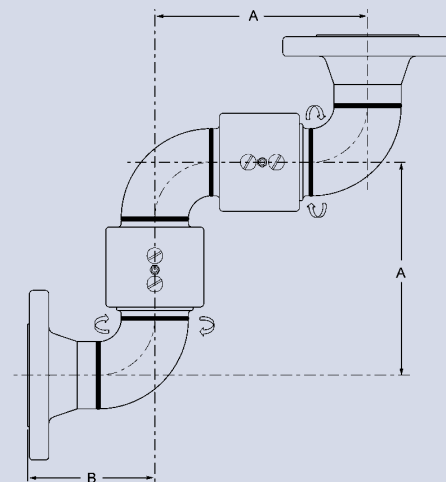

150# ASA f ange x 150# ASA f ange
sizes 1" - 4"

K

Typical Applications for O-Ring Swivels

Loading Arms

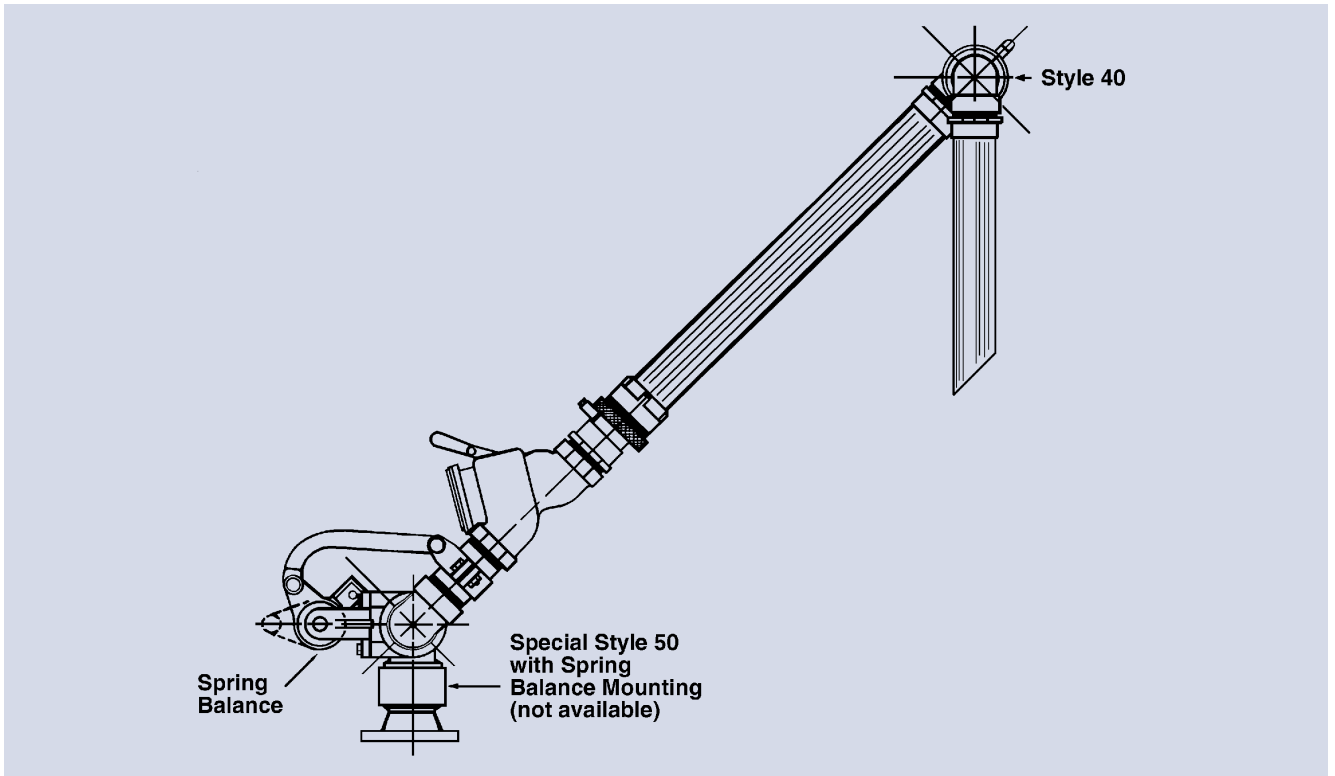

Hose Loaders

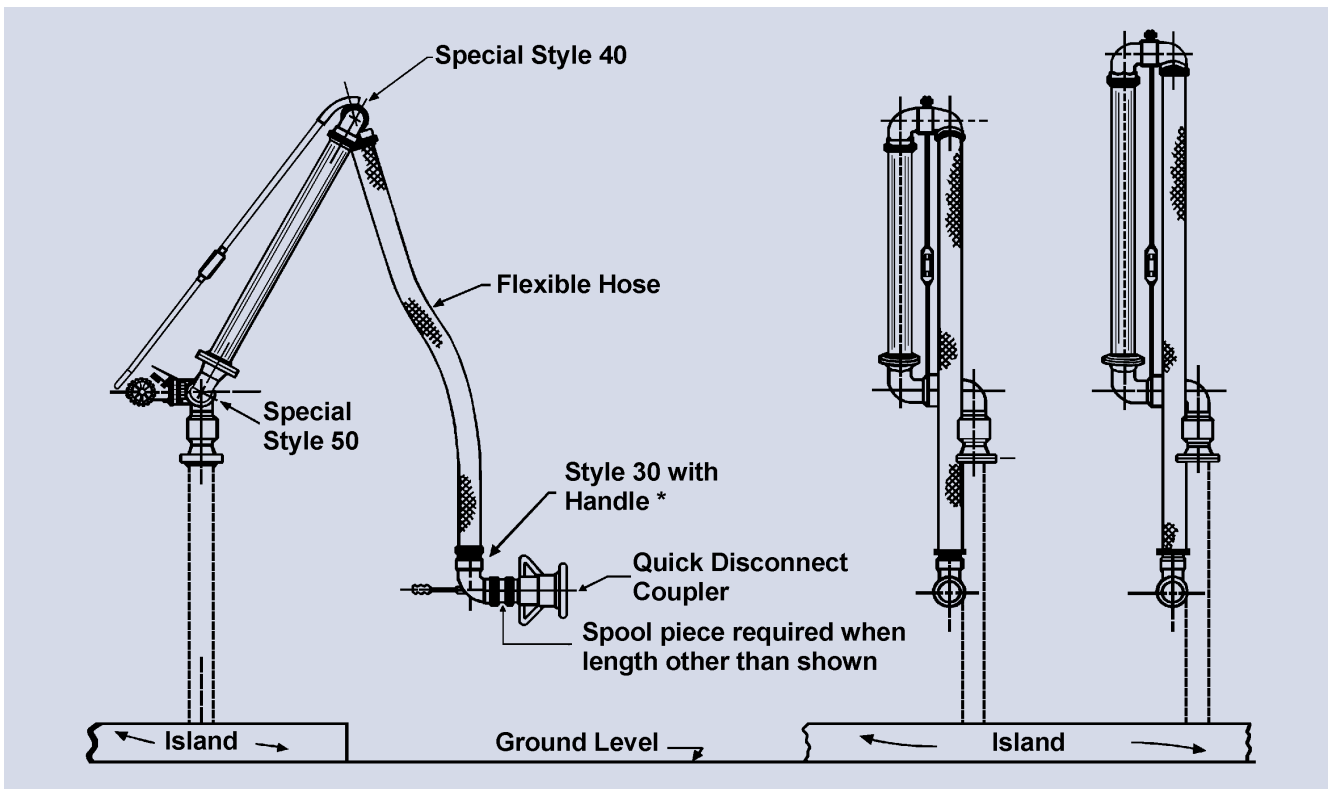

* style 60 may also be found in this application

Dry Disconnect Couplings

When your product is:

- Expensive
- Expensive to clean up
- Expensive to reprocess or dispose
- Hazardous to workers or the environment
- Prone to accidental spillage and product loss



Dry Disconnect Couplings are designed for quick and spill free connection and disconnection of hoses and pipelines. They are used by producers of ink, adhesives, fatty acids, pharmaceuticals, liquid soaps, petroleum, chemicals, agricultural and a wide variety of common caustic and specialty acids.

- **Easy to handle -**
Push and turn - free flow, turn and pull - closed
- **Time saving-**
No need to drain hoses or pipe systems
- **Economical-**
No loss or spillage of liquids at connection or disconnection
- **Safety-**
The valve cannot be opened until the unit is coupled
- **Environment friendly-**
Accidental spillage eliminated
- **Safe and reliable-**
Due to rugged construction
- **Selectivity-**
Optional selectivity for preventing contamination due to incorrect and cross-coupling
- **Product life-**
Uncomplicated design and high quality materials ensures longer product life
- **Working Pressure -**
Aluminum: 260 psi / 18 bar
Brass/ Gunmetal: 360 psi / 25 bar
Stainless Steel: 360 psi / 25 bar
- **Optional Seals-**
EPDM BR - nitrile
Kalrez® Chemraz®
Perlast®

Interchanges with Avery Hardoll and Todo-matic®

K

How it works

The principle of operation is identical for all sizes of couplings.

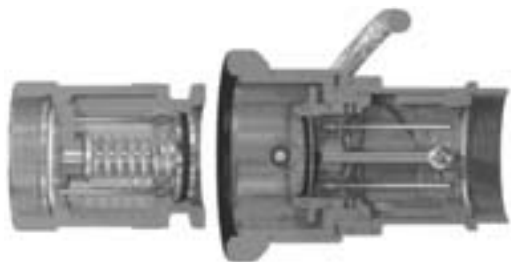

CLOSED:

- Turn and pull
It's released - no spillage



OPEN:

- Push and turn
It's coupled - full flow

Dry Quick Disconnect Couplers

Hose Unit

- Coupler has built-in swivel
- Stainless Steel ball bearings
- Shaft journal in stainless steel embedded in PTFE to eliminate seizure
- Riveted piston pin to minimise the risk for failure under extreme pressure conditions
- Protecting ring is weather resistant rubber
- Electrically conductive
- All wetted parts are stainless steel
- Rollers for the stainless steel units are Hastelloy™ C276 on the stainless steel shaft
- Rollers for the Aluminium and Brass units are Aluminium-bronze on the stainless steel shaft



DRY QUICK DISCONNECT COUPLERS x FEMALE THREAD WITH VITON® SEALS

PART NO.	FEMALE NTP/BSP	BODY SIZE	BODY MATERIAL
DDC150SS	1 1/2"	70mm	316 Stainless Steel
DDC200SS	2"	70mm	316 Stainless Steel
DDC300SS105	3"	105mm	316 Stainless Steel
DDC300SS	3"	119mm	316 Stainless Steel
DDC400SS	4"	164mm	316 Stainless Steel
DDC150AL	1 1/2"	70mm	Anodised Aluminium
DDC200AL	2"	70mm	Anodised Aluminium
DDC300AL105	3"	105mm	Anodised Aluminium
DDC300AL	3"	119mm	Anodised Aluminium
DDC400AL	4"	164mm	Anodised Aluminium
DDC150BR	1 1/2"	70mm	Brass
DDC200BR	2"	70mm	Brass
DDC300GM105	3"	105mm	Gunmetal
DDC300GM	3"	119mm	Gunmetal
DDC400GM	4"	164mm	Gunmetal



COMPOSITE DUST PLUGS FOR COUPLERS

PART NO.	SIZE	BODY SIZE
DDDP150	1 1/2" and 2"	70mm
DDDP300105	3"	105mm
DDDP300	3"	119mm
DDDP400	4"	164mm

K

Dry Quick Disconnect Adapters

Tank Unit

- The adapter is usually installed on the tank or manifold
- Available in female NPT/BSP or 150# ASA flange
- Conical valve seat to eliminate the risk for "piston blow out"
- PTFE bearing between the piston shaft and the piston guide to eliminate the risk for seizure

Construction:

- Aluminium adapter - Aluminium poppet, stainless steel internal parts
- Stainless Steel adapter - Stainless steel poppet, stainless steel internal parts
- Brass / Gunmetal adapter - Brass poppet, Brass and stainless steel internal parts



DRY QUICK DISCONNECT ADAPTERS x FEMALE THREAD WITH VITON® SEALS

PART NO.	FEMALE NPT/BSP	BODY SIZE	BODY MATERIAL
DDA150SS	1 1/2"	70mm	316 Stainless Steel
DDA200SS	2"	70mm	316 Stainless Steel
DDA300SS105	3"	105mm	316 Stainless Steel
DDA300SS	3"	119mm	316 Stainless Steel
DDA400SS	4"	164mm	316 Stainless Steel
DDA150AL	1 1/2"	70mm	Anodised Aluminium
DDA200AL	2"	70mm	Anodised Aluminium
DDA300AL105	3"	105mm	Anodised Aluminium
DDA300AL	3"	119mm	Anodised Aluminium
DDA400AL	4"	164mm	Anodised Aluminium
DDA150BR	1 1/2"	70mm	Brass
DDA200BR	2"	70mm	Brass
DDA300GM105	3"	105mm	Gunmetal
DDA300GM	3"	119mm	Gunmetal
DDA400GM	4"	164mm	Gunmetal

DRY QUICK DISCONNECT ADAPTERS x 150# ASA FLANGE WITH VITON® SEALS

PART NO.	FEMALE NPT/BSP	BODY SIZE	BODY MATERIAL
DDA150SSFL	1 1/2"	70mm	316 Stainless Steel
DDA200SSFL	2"	70mm	316 Stainless Steel
DDA300SS105FL	3"	105mm	316 Stainless Steel
DDA300SSFL	3"	119mm	316 Stainless Steel
DDA400SSFL	4"	164mm	316 Stainless Steel
DDA150ALFL	1 1/2"	70mm	Anodised Aluminium
DDA200ALFL	2"	70mm	Anodised Aluminium
DDA300AL105FL	3"	105mm	Anodised Aluminium
DDA300ALFL	3"	119mm	Anodised Aluminium
DDA400ALFL	4"	164mm	Anodised Aluminium
DDA150BRFL	1 1/2"	70mm	Brass
DDA200BRFL	2"	70mm	Brass
DDA300GM105FL	3"	105mm	Gunmetal
DDA300GMFL	3"	119mm	Gunmetal
DDA400GMFL	4"	164mm	Gunmetal

COMPOSITE DUST CAPS FOR ADAPTERS

PART NO.	SIZE	BODY SIZE
DDDC150	1 1/2" and 2"	70mm
DDDC300105	3"	105mm
DDDC300	3"	119mm
DDDC400	4"	164mm



Dry Break Cam and Groove Dry Disconnect Couplings

Compatible with most cam and groove style dry disconnects. The Bayco dry disconnect helps prevent spillage from normal or accidental disconnects. A spring loaded sealing device is designed to snap closed should the valve become disconnected with the poppet open, significantly limiting liquid loss.

Our dry disconnect couplings are available in a wide range of sizes, metals, and seal materials. Please refer to our product description cross-reference chart for details. Special configurations can be designed for your application.

Couplers

- Dry disconnect coupler has automatic closing poppet assembly
- Heavy duty stainless steel crank and link provide long service life
- Stainless steel handle allows product exposure to corrosive chemicals or washdown service
- Strong handle attachment prevents bending of crank assembly
- Fully interchangeable with Kamvalok (OPW trademark) style fittings
- Aluminum fittings have stainless steel internals*
- For pressure ratings at other temperatures, contact the factory
- Dixon EZ Boss-Lock cam arms provide high security from accidental opening due to vibration or snagging on 1½" and 2" fittings
- Large paddle type cam arms allow for an easy grip on 3" fittings

SAFETY ALERT

Must be used with a DBA style adapter for coupler to operate. Adapter sold separately.



1½" and 2" coupler x female NPT



1½" and 2" coupler x female NPT

COUPLER x FEMALE NPT					
ALUMINIUM PART NO.	STAINLESS STEEL* PART NO.	FEMALE NPT	COUPLER SIZE	SEAL MATERIAL	MAX. PSI AT 70°C
DBC61-150	DBC71-150	1½"	2"	Buna	210
DBC61-200	DBC71-200	2"	2½"		150
DBC61-300	DBC71-300	3"	4"		120
DBC62-150	DBC72-150	1½"	2"	Viton®	210
DBC62-200	DBC72-200	2"	2½"		150
DBC62-300	DBC72-300	3"	4"		120
DBC63-150	DBC73-150	1½"	2"	PTFE Encapsulated Silicone & Kalrez®	210
DBC63-200	DBC73-200	2"	2½"		150
DBC63-300	DBC73-300	3"	4"		120
DBC64-150	DBC74-150	1½"	2"	EPT	210
DBC64-200	DBC74-200	2"	2½"		150
DBC64-300	DBC74-300	3"	4"		120
---	DBC76-150	1½"	2"	Kalrez® and PTFE**	210
DBC66-200	DBC76-200	2"	2½"		150
---	DBC76-300	3"	4"		120
---	DBC77-150	1½"	2"	PTFE Encapsulated Viton® & Kalrez® Viton® B	210
---	DBC77-200	2"	2½"		150
---	DBC77-300	3"	4"		120
DBC69-300	DBC79-300	3"	4"		120

GREASELESS COUPLER x FEMALE NPT				
STAINLESS STEEL* PART NO.	FEMALE NPT	COUPLER SIZE	SEAL MATERIAL	MAX. PSI AT 70°C
DBC77-150-GL	1½"	2"	PTFE Encapsulated Viton® & Kalrez®	210
DBC77-200-GL	2"	2½"		150

* Stainless steel corrosion resistance is comparable to 304 stainless steel

**Kalrez® gasket, main seal O-ring and handle O-ring. PTFE seals on cylinder assembly, stuffing box, and seal under poppet screw.



COUPLER x 90° SWIVEL FEMALE NPT				
ALUMINIUM PART NO.	FEMALE NPT	COUPLER SIZE	SEAL MATERIAL	MAX. PSI AT 70°C
DBS61-200	2"	2½"	Buna	150
DBS62-200	2"	2½"	Viton®	150
DBS63-200	2"	2½"	PTFE Encapsulated Silicone & Kalrez®	150

Dust Plug for Couplers



DUST PLUG FOR COUPLERS		
ALUMINIUM PART NO.	STAINLESS STEEL* PART NO.	SIZE
200-DP-AL	200-DP-SS	2"
250-DP-AL	250-DP-SS	2½"
400-DP-AL	400-DP-SS	4"

* Stainless steel corrosion resistance is comparable to 304 stainless steel

Locking Kit for Couplers



LOCKING KIT FOR COUPLERS	
ALUMINIUM PART NO.	DESCRIPTION
DBCL-200 DBCL-300	for use with 1½" and 2" dry disconnect couplers for use with 3" dry disconnect couplers

Adapters

- Two-piece adapter design for easy rebuilding of adapters
- Fully interchangeable with Kamvalok (OPW trademark) style fittings
- Aluminum fittings have aluminum nose piece and brass piston
- For pressure ratings at other temperatures, contact the factory



1 1/2" and 2" adapter



3" adapter

ADAPTER X FEMALE NPT					
ALUMINIUM PART NO.	STAINLESS STEEL* PART NO.	FEMALE NPT	ADAPTER SIZE	SEAL MATERIAL	MAX. PSI AT 70°C
DBA11-150	DBA71-150	2"	2"	Buna	210
DBA11-200	DBA71-200	2 1/2"	2 1/2"		150
DBA11-300	DBA71-300	4"	4"		120
DBA12-150	DBA72-150	2"	2"	Viton®	210
DBA12-200	DBA72-200	2 1/2"	2 1/2"		150
DBA12-300	DBA72-300	4"	4"		120
DBA63-150	DBA73-150	2"	2"	PTFE Encapsulated Silicone	210
DBA63-200	DBA73-200	2 1/2"	2 1/2"		150
DBA63-300	DBA73-300	4"	4"		120
DBA64-150	DBA74-150	2"	2"	EPT	210
DBA64-200	DBA74-200	2 1/2"	2 1/2"		150
DBA64-300	DBA74-300	4"	4"		120
DBA66-150	DBA76-150	2"	"	Kalrez®	210
DBA66-200	DBA76-200	2 1/2"	4"		150
DBA66-300	DBA76-300	4"			PTFE Encapsulated
---	DBA77-150	2"		Viton®	210
---	DBA77-200	2 1/2"		Viton® B	150
---	DBA77-300	4"			120
DBA69-300	---	4"			120

JUMP SIZE ADAPTER X FEMALE NPT				
ALUMINIUM PART NO.	FEMALE NPT	ADAPTER SIZE	SEAL MATERIAL	MAX. PSI AT 70°C
DBA11-1520	2"	2"	Buna	150
DBA12-1520	2"	2"	Viton®	150

* Stainless steel corrosion resistance is comparable to 304 stainless steel

ADAPTER X 150# ASA FLANGE				
STAINLESS STEEL* PART NO.	FLANGE SIZE	ADAPTER SIZE	SEAL MATERIAL	MAX. PSI AT 70°C
DBAF72-1520	2"	2"	Viton®	150
DBAF73-1520	2"	2"	PTFE Encapsulated Silicone	150
DBAF74-1520	2"	2"	EPT	150
DBAF76-1520	2"	2"	Kalrez®	150
DBAF72-200	2"	2"	Viton®	150
DBAF73-200	2"	2"	PTFE Encapsulated Silicone	150
DBAF74-200	2"	2 1/2"	EPT	150
DBAF76-200	2"	2 1/2"	Kalrez®	150
DBAF72-300	2"	2 1/2"	Viton®	150
DBAF73-300	3"	4"	PTFE Encapsulated Silicone	120
DBAF74-300	3"	4"	EPT	120
DBAF76-300	3"	4"	Kalrez®	120

* Stainless steel corrosion resistance is comparable to 304 stainless steel



VAPOR ADAPTER X FEMALE THREAD				
STAINLESS STEEL* PART NO.	FEMALE NPSM	ADAPTER SIZE	SEAL MATERIAL	MAX. PSI AT 70°C
DBAV73-2030	2"	3"	PTFE	150

* Stainless steel corrosion resistance is comparable to 304 stainless steel

Aluminium Storz Couplings

Sizes: 1/2" to 8"

Materials: Aluminium Alloy
Optional Materials of Stainless Steel and Brass available

Pressure: Maximum working pressure 16 bar/232 psi

Options: Both halves of the coupling are of an identical design with no separate male or female halves. Either half can, therefore, be connected to any similar size of coupling. The hose coupling can be connected to another style, e.g.: hose tail, female or male threaded and blanking caps. It is essential that the distance between locking ears (KA) is the same on all fittings

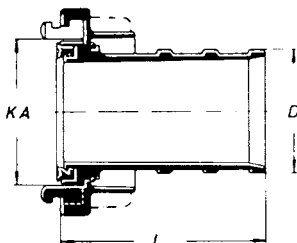

K

SUCTION COUPLINGS				
PART NO.	NOMINAL SIZE	D (mm)	KA (mm)	L (mm)
2/D-25 AL	Storz 25 (D) = DIN 14301	25	31	50
2/32-19 AL	Storz 32	19	44	65
2/32-25 AL	Storz 32	25	44	65
2/32-32 AL	Storz 32	32	44	75
2/38-38 AL	Storz 38	38	52	75
2/C-32 AL	Storz 52 (C)	25	66	90
2/C-38 AL	Storz 52 (C)	32	66	90
2/C-45 AL	Storz 52 (C)	45	66	90
2/C-52 AL	Storz 52 (C) = DIN14321	52	66	90
2/C-60 AL	Storz 52 (C)	60	66	125
2/65-65 AL	Storz 65	65	81	90
2/B-65 AL	Storz 75 (B)	65	89	125
2/B-70 AL	Storz 75 (B)	70	89	95
2/B-75 AL	Storz 75 (B) = DIN 14322	75	89	125
2/B-80 AL	Storz 75 (B)	80	89	135
2/90 AL	Storz 90	90	105	150
2/100 AL	Storz 100	100	115	120
2/A-100 AL	Storz 110 (A)	100	133	170
2/A-110 AL	Storz 110 (A) = DIN 14323	110	133	170
2/125 AL	Storz 125	125	148	196
2/135-135 AL	Storz 135	135	159	196
2/150-150 AL	Storz 150 = F (3 Claws) Forged	150	160	180
2/165-150 AL	Storz 165	150	188	275
2/205 AL	Storz 205	205	220	375
96	Storz Spanner	-	-	-

Rubber Seals (suitable for Petrol and Oil Fluids)

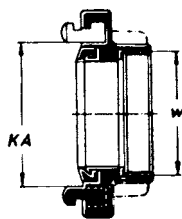

BSSP FEMALE THREADED ADAPTERS

PART NO.	NOMINAL SIZE DIN ISO 228	PIPE THREAD	KA (mm)	MATERIAL
3/D-050 AL	Storz 25 (D) - DS*	1/2"	31	Aluminium Alloy
3/D-075 AL	Storz 25 (D) - DS*	3/4"	31	Aluminium Alloy
3/D-100 AL	Storz 25 (D) - DS* = DIN14306	1"	31	Aluminium Alloy
3/32-100 AL	Storz 32 - DS*	1"	44	Aluminium Alloy
3/32-125 AL	Storz 32 - DS*	1 1/4"	44	Aluminium Alloy
3/38-150 AL	Storz 38 - DS*	1 1/2"	52	Aluminium Alloy
3/38-200 AL	Storz 38 - DS*	2"	52	Aluminium Alloy
3/C-100 AL	Storz 52 (C)	1"	66	Aluminium Alloy
3/C-125 AL	Storz 52 (C)	1 1/4"	66	Aluminium Alloy
3/C-150 AL	Storz 52 (C)	1 1/2"	66	Aluminium Alloy
3/C-200 AL	Storz 52 C = DIN14307	2"	66	Aluminium Alloy
3/C-250 AL	Storz 52 (C)	2 1/2"	66	Aluminium Alloy
3/65-200 AL	Storz 65	2"	81	Aluminium Alloy
3/65-250 AL	Storz 65	2 1/2"	81	Aluminium Alloy
3/B-200 AL	Storz 75 (B)	2"	89	Aluminium Alloy
3/B-250 AL	Storz 75 B = DIN 14308	2 1/2"	89	Aluminium Alloy
3/B-300 AL	Storz 75 (B)	3"	89	Aluminium Alloy
3/90-300 AL	Storz 90	3"	105	Aluminium Alloy
3/100-400 AL	Storz 100 - DS*	4"	115	Aluminium Alloy
3/A-400 AL	Storz 110 (A)	4"	133	Aluminium Alloy
3/A-450 AL	Storz 110 A = DIN 14309	4 1/2"	133	Aluminium Alloy
3/125-500 AL	Storz 125	5"	148	Aluminium Alloy
3/150-600 AL	Storz 150 = F (3 Claws) Forged	6"	160	Aluminium Alloy
3/165-600 AL	Storz 165	6"	188	Aluminium Alloy
3/165-700 AL	Storz 165	7"	188	Aluminium Alloy
3/205-800 AL	Storz 205	8"	220	Aluminium Alloy
96	Storz Spanner	-	-	-

*DS - Suitable for both pressure and suction couplings

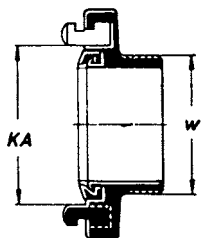

BSSP MALE THREADED ADAPTERS

PART NO.	NOMINAL SIZE DIN ISO 228	PIPE THREAD	KA (mm)	MATERIAL
4/D-100 AL	Storz 25 (D) - DS*	1"	31	Aluminium Alloy
4/D-32-100 AL	Storz 32 DS*	1"	44	Aluminium Alloy
4/32-125 AL	Storz 32 DS*	1 1/4"	44	Aluminium Alloy
4/38-150 AL	Storz 38 - DS*	1 1/2"	52	Aluminium Alloy
4/C-125 AL	Storz 52 (C)	1 1/4"	66	Aluminium Alloy
4/C-200 AL	Storz 52 (C)	2"	66	Aluminium Alloy
4/B-250 AL	Storz 75(B)	2 1/2"	89	Aluminium Alloy
4/B-300 AL	Storz 75(B)	3"	89	Aluminium Alloy
4/A-400 AL	Storz 110(A)	4"	133	Aluminium Alloy

*DS - Suitable for both pressure and suction couplings

Tanker, Overfill Prevention & Storage Tank Products

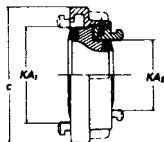

REDUCERS STORZ - STORZ (SWIVEL)

PART NO.	NOMINAL SIZE	KA x KA (mm)	MATERIAL
7/C-D AL	C - D = DIN 14341	66/31	Aluminium Alloy
7/B-C AL	B - C = DIN 14342	89/66	Aluminium Alloy
7/A-B AL	A - A = DIN 14343	133/89	Aluminium Alloy

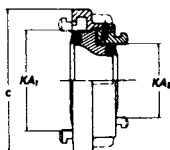

REDUCERS STORZ - STORZ (RIGID)

PART NO.	NOMINAL SIZE	KA x KA (mm)	MATERIAL
7/C-38 AL	Storz C-38	66/52	Aluminium Alloy
7/C-32 AL	Storz C-32	66/44	Aluminium Alloy
7/65-C AL	Storz 65-C	81/66	Aluminium Alloy
7/B-65 AL	Storz B-65	89/81	Aluminium Alloy
7/90-B AL	Storz 90-B	105/89	Aluminium Alloy
7/100-B AL	Storz 100-B	115/89	Aluminium Alloy
7/A-100 AL	Storz A-100	133/115	Aluminium Alloy
7/125-A AL	Storz 125-A	148/133	Aluminium Alloy
7/150-A	Storz 150-A	160/133	Aluminium Alloy

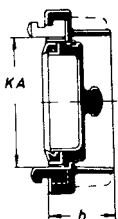

BLANK CAPS WITH CHAIN

PART NO.	NOMINAL SIZE	KA (mm)	MATERIAL I.D. of coupling
8/D AL	Storz 25 D - DS* = DIN 14310	31	Aluminium Alloy
8/32 AL	Storz 32 DS*	44	Aluminium Alloy
8/38 AL	Storz 38 DS*	52	Aluminium Alloy
8/C AL	Storz 52 C = DIN 14311	66	Aluminium Alloy
8/65 AL	Storz 65	81	Aluminium Alloy
8/B AL	Storz 75 B = DIN 14312	89	Aluminium Alloy
8/90 AL	Storz 90	105	Aluminium Alloy
8/100 AL	Storz 100 - DS*	115	Aluminium Alloy
8/A AL	Storz 110 A = DIN 14313	133	Aluminium Alloy
8/125 AL	Storz 125	148	Aluminium Alloy
8/150 AL	Storz 150 = F (3 Claws) forged	160	Aluminium Alloy
8/165 AL	Storz 165	188	Aluminium Alloy
8/205 AL	Storz 205	220	Aluminium Alloy
96	Storz Spanner	-	-

*DS - Suitable for both pressure and suction couplings

K



DELIVERY-SUCTION SEALS	
PART NO.	NOMINAL SIZE
69/D PB	Storz 25 D* = DIN 14301
69/32 PB	Storz 32 - DS*
69/38 PB	Storz 38 - DS*
69/CPB	Storz 52 C = DIN 14311
69/65 PB	Storz 65
69/BPB	Storz 75 B = DIN 14312
69/90 PB	Storz 90
69/100 PB	Storz 100 - DS*
69/A PB	Storz 110 A = DIN 14313
69/125 PB	Storz 125

*DS - Suitable for both pressure & suction couplings.
Food quality material available on request.

Tank Wagon Couplings BS EN 14420-6:2004

STAINLESS STEEL TANKWAGON COUPLINGS		
PART NO.	SIZE	MATERIAL
MK50SS MK80SS MK100SS	DN50 DN80 DN100	Stainless Steel Stainless Steel Stainless Steel
VK50SS VK80SS VK100SS	DN50 DN80 DN100	Stainless Steel Stainless Steel Stainless Steel
VB50SS VB80SS	DN50 DN80	Stainless Steel Stainless Steel
MB50SS MB80SS	DN50 DN80	Stainless Steel Stainless Steel



FORGED BRASS TANKWAGON COUPLINGS		
PART NO.	SIZE	MATERIAL
MK50BR MK80BR MK100BR	DN50 DN80 DN100	Forged Brass Forged Brass Forged Brass
VK50BR VK80BR VK100BR	DN50 DN80 DN100	Forged Brass Forged Brass Forged Brass



Tank Wagon Spares & Seals BS EN 14420-6:2004



STAINLESS STEEL TANKWAGON SPARE PARTS		
PART NO.	SIZE	DESCRIPTION
MKLR 50SS MKLR 80SS MKLR 100SS	DN50 DN80 DN100	Locking Ring Locking Ring Locking Ring
MKSR 50SS MKSR 80SS MKSR 100SS	DN50 DN80 DN100	Sealing Ring Section Sealing Ring Section Sealing Ring Section



FORGED BRASS TANKWAGON SPARE PARTS		
PART NO.	SIZE	DESCRIPTION
MKLR50BR MKLR80BR MKLR100BR	DN50 DN80 DN100	Locking Ring Locking Ring Locking Ring
MKSR50BR MKSR80BR MKSR100BR	DN50 DN80 DN100	Sealing Ring Section Sealing Ring Section Sealing Ring Section

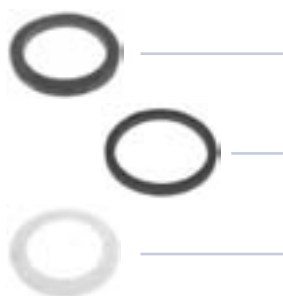

SEALS AND GASKETS FOR TANKWAGON COUPLINGS		
PART NO.	SIZE	DESCRIPTION
MBG50 MBG80 MBG100	DN50 DN80 DN100	Female Blanking Gasket Female Blanking Gasket Female Blanking Gasket
TWHS50 TWHS80 TWHS100	DN50 DN80 DN100	Hypalon Seal Hypalon Seal Hypalon Seal
TS 50T TS 80T TS 100T	DN50 DN80 DN100	PTFE Thread Seal PTFE Thread Seal PTFE Thread Seal

K

Low Pressure Tank Equipment

Our range of low pressure tank equipment is designed to meet the stringent requirements specified for the safe storage of volatile liquids and gasses.

All our products are designed to offer both practical and cost effective solutions in such diverse industries as Petrochemical, Tank storage, Pharmaceutical, Chemical and Oil & Gas. All industries where safety is paramount.

Products

B100 - COMBINED PRESSURE AND VACUUM RELIEF VALVES



The B100 Series ensures that tanks and vessels are kept safe during periods of excessive pressure and vacuum caused by filling and emptying of product and changes in temperature due to climatic or external fire sources. Available as vent to atmosphere and piped away version.

B200 - VACUUM RELIEF VALVES

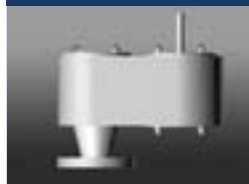

The B200 Series ensures that tanks and vessels are kept safe during periods of excessive vacuum caused by emptying of product and changes in temperature due to climatic changes. Conventional and side mounting options available.

B300 - PRESSURE RELIEF VALVES



The B300 Series ensures that tanks and vessels are kept safe during periods of excessive pressure caused by filling of product and changes in temperature due to climatic or external fire sources. Available as vent to atmosphere and piped away units with the piped away unit also capable of operating as a vacuum relief valve.

B400 - EMERGENCY RELIEF VALVES



The B400 Series ensures that tanks and vessels are kept safe during periods of excessive pressure due to external fire sources and also allows access to the tank for inspection / cleaning purposes.

B500 - GAUGE HATCHES



The B500 Series are designed to provide access to tanks or vessels for sampling, measurement and inspection. Options include self closing, clamp down and lockable.

FOR INFORMATION ON ANY OF THESE PRODUCTS PLEASE DO NOT HESITATE TO CONTACT OUR SALES DEPARTMENT



K



L

Valves - Industrial & General Purpose

Ball / Gate Valves	404-405
Safety Vented Ball	406
Bronze Deadman Spring Return.....	406
Steam Ball.....	407
Carbon Steel Ball	407
Locking Handle Ball	408
Polypropylene Valves	409
Foot Valves, Skimmers & Strainers	410-413
Safety Check Valves.....	414

OTHER VALVE TYPES ARE AVAILABLE IN THE HYGIENIC AND TANKER SECTION

L



Ball / Gate Valves

Sizes: 1/4" to 4"

Materials:

- Brass
- Stainless Steel
- Polypropylene

Pressure: See ratings

Options: Ball Valves can be pneumatically or electrically operated



FULL BORE - MAX. WORKING PRESSURE 580 psi / 40 bar

PART NO.	SIZE	THREAD	MATERIAL
025/335	1/4"	BSP PI.	Brass
038/335	3/8"	BSP PI.	Brass
050/335	1/2"	BSP PI.	Brass
075/335	3/4"	BSP PI.	Brass
100/335	1"	BSP PI.	Brass
125/335	1 1/4"	BSP PI.	Brass
150/335	1 1/2"	BSP PI.	Brass
200/335	2"	BSP PI.	Brass
250/335	2 1/2"	BSP PI.	Brass
300/335	3"	BSP PI.	Brass
400/335	4"	BSP PI.	Brass

GATE VALVE - MAX. WORKING PRESSURE 290 psi / 20 bar

PART NO.	SIZE	THREAD	MATERIAL
GV038BH	3/8"	BSP PI.	Brass
GV050BH	1/2"	BSP PI.	Brass
GV075BH	3/4"	BSP PI.	Brass
GV100BH	1"	BSP PI.	Brass
GV125BH	1 1/4"	BSP PI.	Brass
GV150BH	1 1/2"	BSP PI.	Brass
GV200BH	2"	BSP PI.	Brass
GV250BH	2 1/2"	BSP PI.	Brass
GV300BH	3"	BSP PI.	Brass
GV400BH	4"	BSP PI.	Brass



L



3 PIECE FULL BORE - MAX. WORKING PRESSURE 1000 psi / 67 bar

PART NO.	SIZE	THREAD	MATERIAL
G3/025SS	1/4"	BSP PI./NPT	Stainless Steel
G3/038SS	3/8"	BSP PI./NPT	Stainless Steel
G3/050SS	1/2"	BSP PI./NPT	Stainless Steel
G3/075SS	3/4"	BSP PI./NPT	Stainless Steel
G3/100SS	1"	BSP PI./NPT	Stainless Steel
G3/125SS	1 1/4"	BSP PI./NPT	Stainless Steel
G3/150SS	1 1/2"	BSP PI./NPT	Stainless Steel
G3/200SS	2"	BSP PI./NPT	Stainless Steel



2 PIECE FULL BORE - MAX. WORKING PRESSURE 1000 psi / 67 bar

PART NO.	SIZE	THREAD	MATERIAL
G2/025SS	1/4"	BSP PI./NPT	Stainless Steel
G2/038SS	3/8"	BSP PI./NPT	Stainless Steel
G2/050SS	1/2"	BSP PI./NPT	Stainless Steel
G2/075SS	3/4"	BSP PI./NPT	Stainless Steel
G2/100SS	1"	BSP PI./NPT	Stainless Steel
G2/125SS	1 1/4"	BSP PI./NPT	Stainless Steel
G2/150SS	1 1/2"	BSP PI./NPT	Stainless Steel
G2/200SS	2"	BSP PI./NPT	Stainless Steel



MINI VALVE - PRESSURE RATING 150 psi / 10 bar

PART NO.	SIZE	THREAD	MATERIAL
MBV25	1/4"	NPT	Brass
MBV38	3/8"	NPT	Brass
MBV50	1/2"	NPT	Brass

Blow-out proof stem with chrome ball.

L

Safety Vented Ball Valves

- Sizes:**
- 1/4" to 1/2" Full Port
 - 3/4" to 2" Standard Port
- Material:** Brass
- Pressure:**
- Maximum working pressure 400 psi / 28 bar
 - 150 psi / 10 bar Saturated Steam
- Details:** Female x Female NPT ends. Air only. Lockable ball valves vent downstream air in accordance with new OSHA regulations for pneumatic system.



SAFETY VENTED BALL VALVES		
PART NO.	SIZE	THREAD
BBV25LV	1/4"	NPT
BBV38LV	3/8"	NPT
BBV50LV	1/2"	NPT
BBV75LV	3/4"	NPT
BBV100LV	1"	NPT
BBV125LV	1 1/4"	NPT
BBV150LV	1 1/2"	NPT
BBV200LV	2"	NPT

Bronze "Deadman" Spring Return Handle Valves

- Sizes:**
- 1/2" Full Port
 - 3/4" to 1" Standard Port
- Materials:**
- Bronze Valve Body
 - Stainless Steel Lever
 - Chromium Plated Ball
- Pressure:** 600 psi / 41 bar WOG, 150 psi / 10 bar Steam
- Details:** Female NPT x Female NPT. Standard Port. Operating torque approx. 3 times standard valve torque. Spring return to open and close valve. Reinforced PTFE Seats and Stuffing Box Ring. Blow-out proof Stem design. Adjustable Packing Gland.



BRONZE "DEADMAN" SPRING RETURN HANDLE VALVE		
PART NO.	SIZE	THREAD
BBV50SR	1/2"	NPT
BBV75SR	3/4"	NPT
BBV100SR	1"	NPT

Other sizes available on request.

Steam Ball Valves

- Sizes:** 1/2" to 2" NPT/BSP
- Materials:**
- Threaded Bronze Valve
 - Stainless Steel Ball and Stem
 - Chromium Plated Ball
- Pressure:** 600 psi / 41 bar WOG, 150 psi / 17 bar Steam
- Details:**
- Multi-Fill PTFE Seats
 - Multi-Fill Stuffing Box Ring Blow-out proof Stem design
 - Adjustable Packing Gland



STEAM BALL VALVE		
PART NO.	SIZE	THREAD
BBV50ST	1/2"	NPT / BSP PI.
BBV75ST	3/4"	NPT / BSP PI.
BBV100ST	1"	NPT / BSP PI.
BBV200ST	2"	NPT / BSP PI.

Carbon Steel Ball Valves

- Sizes:** 1/4" to 2" NPT/BSP
- Materials:** Carbon Steel / Lock Handle
- Pressure:**
- Suitable for 150 psi / 10 bar Steam service
 - 1/4" - 1" rated to 2000 psi / 138 bar
 - 1 1/4" - 2" rated to 1500 psi / 103 bar
- Details:** For control of air, water, oil and gas in hose or pipe lines



CARBON STEEL BALL VALVES		
PART NO.	SIZE	THREAD
IBV25	1/4"	NPT / BSP PI.
IBV38	3/8"	NPT / BSP PI.
IBV50	1/2"	NPT / BSP PI.
IBV75	3/4"	NPT / BSP PI.
IBV100	1"	NPT / BSP PI.
IBV125	1 1/4"	NPT / BSP PI.
IBV150	1 1/2"	NPT / BSP PI.
IBV200	2"	NPT / BSP PI.

L

Locking Handle Ball Valves

Sizes: 1/4" to 2" NPT/BSP

Materials: Brass

Pressure:

- Full Port - Rated to 600 psi / 41 bar WOG and 150 psi / 10 bar Steam
- Standard Port - Rated to 400 psi / 28 bar WOG and 125 psi / 9 bar Steam

Details: Female x Female



FULL PORT WITH LOCKING HANDLES

PART NO.	SIZE	THREAD
BBLV25	1/4"	NPT / BSP PI.
BBLV38	3/8"	NPT / BSP PI.
BBLV50	1/2"	NPT / BSP PI.
BBLV75	3/4"	NPT / BSP PI.
BBLV100	1"	NPT / BSP PI.



STANDARD PORT WITH LOCKING HANDLES

PART NO.	SIZE	THREAD
BBLV125	1 1/4"	NPT / BSP PI.
BBLV150	1 1/2"	NPT / BSP PI.
BBLV200	2"	NPT / BSP PI.

Polypropylene Valves



SINGLE UNION			
PART NO.	SIZE	THREAD	MATERIAL
SUBV50	1/2"	NPT	Polypropylene
SUBV75	3/4"	NPT	Polypropylene
SUBV100	1"	NPT	Polypropylene
SUBV125	1 1/4"	NPT	Polypropylene
SUBV150	1 1/2"	NPT	Polypropylene
SUBV200	2"	NPT	Polypropylene
SUBV300	3"	NPT	Polypropylene

- Corrosion resistant Polypropylene
- PTFE ball seats, EPDM 'O' Rings
- Rated to 75 psi



STANDARD PORT VALVES NPT ONLY		
PART NO.	SIZE	DESCRIPTION
PV100	1"	Standard 4 bolt
PV200	2"	Standard 4 bolt

- Precision-moulded from strong, chemical resistant
- Reinforced polypropylene. PTFE seats and EPDM
- 'O' Ring seals. Easy to service and easy
- Non-stick operation. Rated to 125 psi



FULL PORT VALVES NPT ONLY		
PART NO.	SIZE	DESCRIPTION
PVFP50	1/2"	4 bolt
PVFP75	3/4"	4 bolt
PVFP100	1"	4 bolt
PVFP150	1 1/2"	4 bolt
PVFP200	2"	6 bolt
PVFP300	3"	6 bolt

- Precision-moulded from strong, chemical resistant
- Reinforced polypropylene. PTFE seats and EPDM
- 'O' Ring seals. Easy to service and easy
- Non-stick operation. Rated to 125 psi

L

Foot Valves, Skimmers & Strainers



FOOT VALVE (SPRING LOADED)

PART NO.	SIZE	THREAD
FVS038EU	3/8"	BSP PI.
FVS050EU	1/2"	BSP PI.
FVS075EU	3/4"	BSP PI.
FVS100EU	1"	BSP PI.
FVS125EU	1 1/4"	BSP PI.
FVS150EU	1 1/2"	BSP PI.
FVS200EU	2"	BSP PI.
FVS250EU	2 1/2"	BSP PI.
FVS300EU	3"	BSP PI.
FVS400EU	4"	BSP PI.



CAST IRON FOOT VALVE

PART NO.	SIZE	THREAD
FVS200CI/DFVS25	2"	BSP PI./NPT
FVS300CI/DFVS35	3"	BSP PI./NPT
FVS400CI/DFVS40	4"	BSP PI./NPT



STANDARD - THREADED NPT - ROUND HOLE

PART NO.	SIZE	THREAD
RHS20	1 1/2"	NPT
RHS25	2"	NPT
RHS30	2 1/2"	NPT
RHS35	3"	NPT
RHS40	4"	NPT
RHS50	5"	NPT
RHS60	6"	NPT
RHS80	8"	NPT
RHS100	10"	NPT
RHS120	12"	NPT



304 STAINLESS - STEEL THREADED NPT - ROUND HOLE

PART NO.	SIZE	THREAD
RRHS20	1 1/2"	NPT
RRHS25	2"	NPT
RRHS35	3"	NPT
RRHS40	4"	NPT
RRHS60	6"	NPT

L



HOSE SHANKS - ROUND HOLE

PART NO.	SIZE
TCS100	1"
TCS150	1 1/2"
TCS200	2"
TCS300	3"
TCS400	4"
TCS600	6"



STANDARD - THREADED - ROUND HOLE TYPE

PART NO.	SIZE	THREAD
SHS20	1 1/2"	NPT
SHS25	2"	NPT
SHS35	3"	NPT
SHS40	4"	NPT
SHS60	6"	NPT



LONG THIN - ROUND HOLE TYPE

PART NO.	SIZE	THREAD
RSS20	1 1/2"	NPT
RSS25	2"	NPT
RSS30	2 1/2"	NPT
RSS35	3"	NPT
RSS40	4"	NPT



BLACK POLYETHYLENE STRAINER

PART NO.	SIZE	THREAD
TSS20	1 1/2"	NPT
TSS25	2"	NPT
TSS35	3"	NPT

L



SKIMMER - TOP ROUND HOLE TYPE

PART NO.	SIZE	THREAD
DST20	1 1/2"	NPT
DST25	2"	NPT
DST35	3"	NPT

Cast Iron “Y” Strainers

- Sizes:** 1/4” to 2”
- Materials:**
- Cast Iron Body
 - 304 Stainless Steel Screen
- Pressure:**
- 400 psi / 28 bar air and water
 - 250 psi / 17 bar working steam pressure
- Details:** Female x Female NPT ends



CAST IRON “Y” STRAINERS			
PART No.	SIZE	THREAD	DESCRIPTION
Y001	1/4”	NPT	20 x 20 Mesh
Y002	3/8”	NPT	20 x 20 Mesh
Y003	1/2”	NPT	20 x 20 Mesh
Y004	3/4”	NPT	20 x 20 Mesh
Y005	1”	NPT	20 x 20 Mesh
Y006	1 1/4”	NPT	20 x 20 Mesh
Y007	1 1/2”	NPT	20 x 20 Mesh
Y008	2”	NPT	20 x 20 Mesh

Bronze “Y” Strainers

- Sizes:** 1/4” to 2”
- Materials:**
- Cast Bronze Body
 - 304 Stainless Steel Screen
- Pressure:**
- 400 psi / 28 bar air and water
 - 300 psi / 20 bar working steam pressure
- Details:** Female x Female NPT ends



BRONZE “Y” STRAINERS			
PART No.	SIZE	THREAD	DESCRIPTION
59-001	1/4”	NPT	50 x 50 Mesh
59-002	3/8”	NPT	50 x 50 Mesh
59-003	1/2”	NPT	50 x 50 Mesh
59-004	3/4”	NPT	50 x 50 Mesh
59-005	1”	NPT	50 x 50 Mesh
59-006	1 1/4”	NPT	50 x 50 Mesh
59-007	1 1/2”	NPT	50 x 50 Mesh
59-008	2”	NPT	50 x 50 Mesh

L

Polypropylene Line "Y" Strainer

- Sizes:** 3/4" to 2"
- Materials:**
- Glass filled Polypropylene
 - All mesh Stainless Steel Screen
- Pressure:** Maximum working pressure 90 psi / 6 bar at 21°C (70°F)
- Details:**
- Female x Female NPT ends
 - Protects and prevents clogging of pipelines, pumps and spray tips
 - Easy access for cleaning



POLYPROPYLENE LINE "Y" STRAINERS			
PART No.	SIZE	THREAD	DESCRIPTION
PYLS7540	3/4"	NPT	40 Mesh
PYLS10040	1"	NPT	40 Mesh
PYLS15040	1 1/2"	NPT	40/20 Mesh
PYLS20040	2"	NPT	40/20 Mesh

Polypropylene Line "T" Strainer

- Sizes:** 3/4" to 1"
- Materials:**
- Polypropylene
 - All mesh Stainless Steel Screen
- Pressure:** Maximum working pressure 100 psi / 7 bar at 21°C (70°F)
- Details:**
- Female x Female NPT ends
 - Translucent polypropylene allows easy inspection



POLYPROPYLENE LINE "T" STRAINERS			
PART No.	SIZE	THREAD	DESCRIPTION
PTLS7540	3/4"	NPT	40 Mesh
PTLS10040	1"	NPT	40 Mesh

ADDITIONAL FILTERS AND STRAINERS AVAILABLE IN HYGIENIC SECTION

Safety Check Valves & Excess Flow

Details: For portable air compressors. Complies with OSHA requirements. Full flow and functions efficiently at high discharge temperatures. Automatically and instantly protects against hose whip. Resets automatically after airline re-pressurises..

Sizes: 1/4" to 3"

Materials: Brass body and valve construction
Stainless Steel spring and roll pin

Pressure: Maximum working pressure 250 psi / 17 bar

Temperature: Maximum 121°C (250°F)

Purpose: Automatically senses change in air flow and shuts off the flow in the event of a surge in excess of valve rating. Fully conforms to OSHA regulation 1926.302 requiring safety device at source of air supply and at branch air lines. Controls air flow in only one direction, however, permits flow in either direction.

Use: The cut off flow of the selected valve must be less than the actual flow that would occur should a hose or coupling fail. The valve selection must be based on additional guidelines other than compressor rating or hose size. Air flow (scfm) varies with distance of flow and restrictions within each system. Select the pipe size which is the same as the hose with which it will be used. To avoid nuisance cut-offs, the valve should have a nominal cut-off rating of 110% of the maximum consumption of the air tool to be used. Install a cut off valve in each line and branch line subject to rupturing or accidental disconnection. Test each valve for proper function at installation and periodically thereafter. The only time one of these valves will not perform properly is when the tool usage and maximum line flow are close to equal. When start-up is underway, open the Air Control Valve at the Compressor or Manifold VERY SLOWLY to allow air to bleed through the Check Valve so that pressure is equalised on each side of the valve. If the valve fails to operate despite meeting all conditions, check the hose line for obstructions or a Hose Mender restricting normal air flow.

For Rotary Screw & Rotary Vane and Reciprocating Compressors



SAFETY CHECK VALVES & EXCESS FLOW

PART NO.	BSP & HOSE I.D. SIZE	CUT-OFF FLOW RATE (CFM at 90 psi)
SCVL2-BSP	1/4"	23-29
SCVM3-BSP	3/8"	39-47
SCVS3-BSP	3/8"	52-65
SCVM4-BSP	1/2"	70-78
SCVS4-BSP	1/2"	80-96
SCVL6-BSP	3/4"	72-88
SCVM6-BSP	3/4"	92-108
SCVR6-BSP	3/4"	112-128
SCVJ6-BSP	3/4"	132-148
SCVS6-BSP	3/4"	160-180
SCVH6-BSP	3/4"	180-200
SCVL8-BSP	1"	165-195
SCVM8-BSP	1"	220-260
SCVS8-BSP	1"	280-320
SCVH8-BSP	1"	310-340
SCVL10-BSP	1 1/4"	260-290
SCVM10-BSP	1 1/4"	300-340
SCVS10-BSP	1 1/4"	440-500
SCVH10-BSP	1 1/4"	570-630
SCVL12-BSP	1 1/2"	300-360
SCVM12-BSP	1 1/2"	470-530
SCVS12-BSP	1 1/2"	640-720
SCVH12-BSP	1 1/2"	750-830
SCVL16-BSP	2"	510-590
SCVM16-BSP	2"	725-825
SCVS16-BSP	2"	900-1050
SCVH16-BSP	2"	1100-1200
SCVL24-BSP	3"	1200-1400
SCVS24-BSP	3"	2400-2700
SCVH24-BSP	3"	2850-3050

**NOT TO BE USED
IN SAND BLASTING
APPLICATIONS OR
WHERE 100% OF
THE AVAILABLE
AIR IS REQUIRED**

L

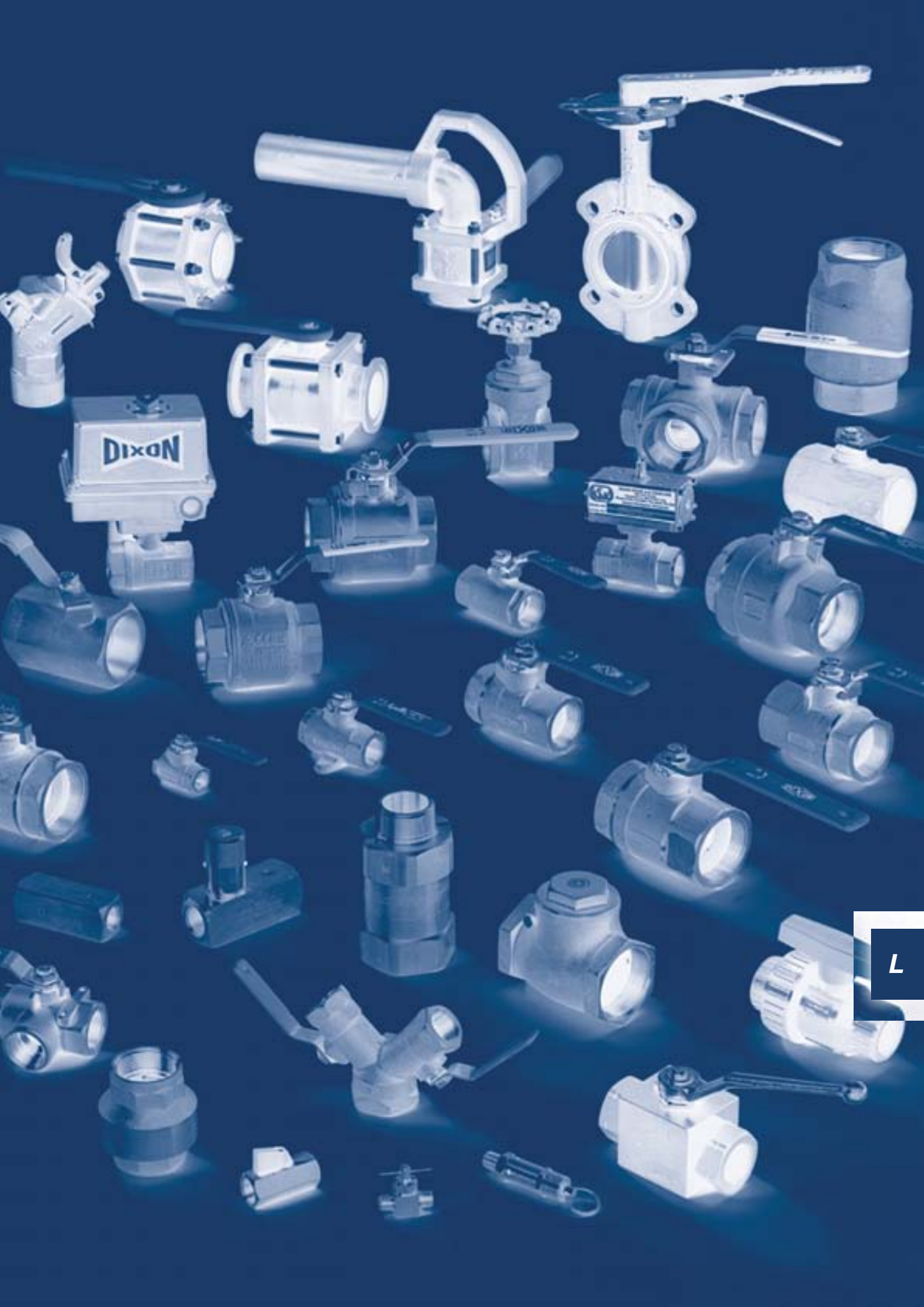

L



M

Water Couplings

Agri-Lock Couplings.....	418-421
Standard Couplings	422
Rigidlok Couplings	423
Lightweight Couplings.....	424
Hingelok Coupling.....	425
Victaulic Groove End Fittings	426
Gaskets.....	427
Geka Type Brass Quick Couplings.....	428
King Shank Lugged Water Couplings.....	429-431
King Combination Nipples.....	432-436
King Crimp System	437-439
Washdown Guns.....	440-441

**FOR A FULL RANGE OF WATER HOSES
TO COMPLEMENT THESE FITTINGS SEE SECTION F**

M



Agri-Lock Couplings

Sizes: 2" to 8"

Materials: Carbon Steel with a galvanised or zinc plated protective finish
Ungalvanised Carbon Steel suitable for welding

Pressure (All sizes): Maximum Working Pressure 150 psi / 10 bar

Details: Agri-lock couplings are a robust and cost effective water coupling fully interchangeable with other manufacturers



AGRI-LOCK COMPLETE SETS

PART NO.	SIZE
ALCS2	2"
ALCS3	3" tail x 3"
ALCS3.5	3" tail x 3 1/2"
ALCS4	4"
ALCS5	5"
ALCS6	6"
ALCS8	8"



AGRI-LOCK MALE X HOSE TAIL (LEVER RING NOT INCLUDED)

PART NO.	SIZE
ALM2	2"
ALM3	3" tail x 3"
ALM3.5	3" tail x 3 1/2"
ALM4	4"
ALM5	5"
ALM6	6"
ALM8	8"



AGRI-LOCK LEVER RING TO SUIT ABOVE

PART NO.	SIZE
ALL2	2"
ALL3	3" tail x 3"
ALL3.5	3" tail x 3 1/2"
ALL4	4"
ALL5	5"
ALL6	6"
ALL8	8"



AGRI-LOCK FEMALE X HOSE TAIL (PRICE INCLUDES 'O' RING)

PART NO.	SIZE
ALF2	2"
ALF3	3" tail x 3"
ALF3.5	3" tail x 3 1/2"
ALF4	4"
ALF5	5"
ALF6	6"
ALF8	8"



AGRI-LOCK RUBBER 'O' RING

PART NO.	SIZE
ALO2	2"
ALO3	3" tail x 3"
ALO3.5	3" tail x 3 1/2"
ALO4	4"
ALO5	5"
ALO6	6"
ALO8	8"



AGRI-LOCK FEMALE WELD END

PART NO.	SIZE
ALFW2	2" x 50mm
ALFW3	3" x 76mm
ALFW3.5	3" x 89mm
ALFW4	4" x 108mm
ALFW6	6" x 159mm
ALFW8	8" x 194mm



AGRI-LOCK MALE WELD END

PART NO.	SIZE
ALMW2	2" x 50mm
ALMW3	3" x 76mm
ALMW3.5	3" x 89mm
ALMW4	4" x 108mm
ALMW6	6" x 159mm



AGRI-LOCK MALE X FIXED FLANGE (CLAMP INCLUDED)

PART No.	SIZE	FLANGE DESCRIPTION
ALMF2D	50mm	BS10 Table D
ALMF3D	76mm	BS10 Table D
ALMF3.5D	89mm	BS10 Table D
ALMF4D	108mm	BS10 Table D
ALMF5D	133mm	BS10 Table D
ALMF6D	159mm	BS10 Table D
ALMF8D	194mm	BS10 Table D
ALMF2NP16	50mm	BS4504PN16
ALMF3NP16	76mm	BS4504PN16
ALMF3.5NP16	89mm	BS4504PN16
ALMF4NP16	108mm	BS4504PN16
ALMF5NP16	133mm	BS4504PN16
ALMF6NP16	159mm	BS4504PN16
ALMF8NP16	194mm	BS4504PN16
ALMF2E	50mm	BS10 Table E
ALMF3E	76mm	BS10 Table E
ALMF3.5E	89mm	BS10 Table E
ALMF4E	108mm	BS10 Table E
ALMF5E	133mm	BS10 Table E
ALMF6E	159mm	BS10 Table E
ALMF8E	194mm	BS10 Table E



AGRI-LOCK BLANK FOR FEMALE ENDS

PART No.	SIZE
ALFB2	50mm
ALFB3	76mm
ALFB3.5	89mm
ALFB4	108mm
ALFB5	133mm
ALFB6	159mm
ALFB8	194mm



AGRI-LOCK FEMALE X FIXED FLANGE ('O' RING NOT INCLUDED)

PART No.	SIZE	FLANGE DESCRIPTION
ALFF2D	50mm	BS10 Table D
ALFF3D	76mm	BS10 Table D
ALFF3.5D	89mm	BS10 Table D
ALFF4D	108mm	BS10 Table D
ALFF5D	133mm	BS10 Table D
ALFF6D	159mm	BS10 Table D
ALFF8D	194mm	BS10 Table D
ALFF2NP16	50mm	BS4504PN16
ALFF3NP16	76mm	BS4504PN16
ALFF3.5NP16	89mm	BS4504PN16
ALFF4NP16	108mm	BS4504PN16
ALFF5NP16	133mm	BS4504PN16
ALFF6NP16	159mm	BS4504PN16
ALFF8NP16	194mm	BS4504PN16
ALFF2E	50mm	BS10 Table E
ALFF3E	76mm	BS10 Table E
ALFF3.5E	89mm	BS10 Table E
ALFF4E	108mm	BS10 Table E
ALFF5E	133mm	BS10 Table E
ALFF6E	159mm	BS10 Table E
ALFF8E	194mm	BS10 Table E



AGRI-LOCK BLANK FOR MALE ENDS

PART No.	SIZE
ALMB2	50mm
ALMB3	76mm
ALMB3.5	89mm
ALMB4	108mm
ALMB5	133mm
ALMB6	159mm
ALMB8	194mm



AGRI-LOCK FEMALE X MALE REDUCER (CLAMP INCLUDED BUT NOT 'O' RING)

PART No.	SIZE
ALMFR3X2	76mm female x 50mm male
ALMFR3.5X2	89mm female x 50mm male
ALMFR3.5X3	89mm female x 76mm male
ALMFR4X3	108mm female x 76mm male
ALMFR4X3.5	108mm female x 89mm male
ALMFR5X4	133mm female x 108mm male
ALMFR6X4	159mm female x 108mm male
ALMFR8X6	194mm female x 159mm male



AGRI-LOCK MALE X FEMALE ADAPTER (CLAMP INCLUDED BUT NOT 'O' RING)

PART No.	SIZE
ALMFA2X3	50mm female x 76mm male
ALMFA2X3.5	50mm female x 89mm male
ALMFA3X3.5	76mm female x 89mm male
ALMFA3X4	76mm female x 108mm male
ALMFA3.5X4	89mm female x 108mm male
ALMFA4X5	108mm female x 133mm male
ALMFA4X6	108mm female x 159mm male
ALMFA5X6	133mm female x 159mm male
ALMFA5X8	133mm female x 203mm male



AGRI-LOCK MALE X BSPT (LEVER RING INCLUDED)

PART No.	SIZE
ALMM2X1.5	50mm x 1 1/2"bspt
ALMM2X2	50mm x 2"bspt
ALMM3X2.5	76mm x 2 1/2"bspt
ALMM3X3	76mm x 3"bspt
ALMM3.5X3	89mm x 3"bspt
ALMM4X4	108mm x 4"bspt
ALMM5X5	133mm x 5"bspt
ALMM6X6	159mm x 6"bspt
ALMM8X8	194mm x 8"bspt



AGRI-LOCK FEMALE x BSPT ('O' RING NOT INCLUDED)

PART No.	SIZE
ALFM2X1.5	50mm x 1 1/2"bspt
ALFM2X2	50mm x 2"bspt
ALFM3X2.5	76mm x 2 1/2"bspt
ALFM3X3	76mm x 3"bspt
ALFM3.5X3	89mm x 3"bspt
ALFM4X4	108mm x 4"bspt
ALFM5X5	133mm x 5"bspt
ALFM6X6	159mm x 6"bspt
ALFM8X8	194mm x 8"bspt



AGRI-LOCK 'T' UNION, MALE x FEMALE ON THE HORIZONTAL WITH MALE OUTLET

PART No.	SIZE
ALT2M	50mm
ALT3M	76mm
ALT3.5M	89mm
ALT4M	108mm
ALT5M	133mm
ALT6M	159mm
ALT8M	194mm



AGRI-LOCK 'T' UNION, MALE x FEMALE ON THE HORIZONTAL WITH FEMALE OUTLET

PART No.	SIZE
ALT2F	50mm
ALT3F	76mm
ALT3.5F	89mm
ALT4F	108mm
ALT5F	133mm
ALT6F	159mm
ALT8F	194mm

M

Standard Couplings

- Sizes:** 1 1/2" to 8"
- Materials:** Malleable Iron
- Pressure:** Allows for working pressure ratings up to 1000 psi
- Details:** The standard Coupling is designed for a wide range of applications with a housing design that allows for optimum strength without excessive casting weight
- Applications:**
- Commercial/Industrial Construction
 - Mining
 - Process piping
- Interchange Guide:**
- Victaulic's #7
 - Grinnell's #7001



STANDARD COUPLING

PART NO. w/EPDM SEAL	w/BUNA-N SEAL	NOMINAL SIZE (inches)	PIPE O.D. (inches)	MAX WORKING PRESSURE	MAX END LOAD (lbs)	APPROX WEIGHT EACH (lbs)
C115	C115BU	1 1/2"	1.900	1000 psi / 70 bar	2835	2.2
C12	C12BU	2"	2.375	1000 psi / 70 bar	4430	2.9
C125	C125BU	2 1/2"	2.875	1000 psi / 70 bar	6492	3.1
C13	C13BU	3"	3.500	1000 psi / 70 bar	9621	3.7
C14	C14BU	4"	4.500	1000 psi / 70 bar	15904	6.3
C16	C16BU	6"	6.625	1000 psi / 70 bar	34472	13.3
C18	C18BU	8"	8.625	800 psi / 55 bar	46741	20.4

Rigidlok™ Couplings

Sizes: 1 1/2" to 6"

Materials: Malleable Iron

Pressure: Allows for working pressure ratings up to 1000 psi

Details: The patented Rigidlok™ Coupling utilises a unique approach to providing pipe joint rigidity. A specially designed coupling housing conforms to and grips the pipe over an increasing area as the bolts are tightened. An innovative bolt-hole-offset design also spreads the coupling assembly to fill the grooves. The combined effect produces a secure rigid joint over a wide range of service conditions.

Interchange Guide:

- Victaulic's #07
- Grinnell's #7401(old style) /7007



RIGIDLOK™ COUPLING								
PART NO. w/EPDM SEAL	w/BUNA-N SEAL	NOMINAL SIZE	OUTSIDE DIAM. (inches)	WALL THICK	SCHEDULE NUMBER	MAX WORKING	MAX END LOAD PRESSURE	FIXED PIPE END (lbs)
R715	R715BU	1 1/2"	1.900	0.145	40	500 psi / 35 bar	2835	0.13
R72	R72BU	2"	2.375	0.154	40	500 psi / 35 bar	4430	0.13
R725	R725BU	2 1/2"	2.875	0.203	40	500 psi / 35 bar	6492	0.13
R73	R73BU	3"	3.500	0.216	40	500 psi / 35 bar	9621	0.13
R74	R74BU	4"	4.500	0.237	40	500 psi / 35 bar	12720	0.25
R75	R75BU	5"	5.523	0.258	40	500 psi / 35 bar	19440	0.25
R76	R76BU	6"	6.625	0.280	40	500 psi / 35 bar	27570	0.25

Lightweight Couplings

- Sizes:** 1 1/2" to 8"
- Materials:** Malleable Iron
- Pressure:** Allows for working pressure ratings up to 500psi/ 35bar
- Details:** The Patented Lightweight Coupling is designed for applications requiring moderate internal pressure or where weight is a factor
- Interchange Guide:**
- Victaulic's #75
 - Grinnell's #7001



LIGHTWEIGHT COUPLING						
PART NO. w/EPDM SEAL	w/BUNA-N SEAL	NOMINAL SIZE (inches)	PIPE O.D. (inches)	MAX WORKING PRESSURE	MAX END LOAD (lbs)	APPROX WEIGHT EACH (lbs)
L215	L215BU	1 1/2"	1.900	500 psi / 35 bar	1418	1.5
L02	L02BU	2"	2.375	500 psi / 35 bar	2215	1.9
L025	L025BU	2 1/2"	2.875	500 psi / 35 bar	3246	2.0
L03	L03BU	3"	3.500	500 psi / 35 bar	4811	2.7
L04	L04BU	4"	4.500	500 psi / 35 bar	6362	4.3
L05	L06BU	5"	5.563	500 psi / 35 bar	9722	5.9
L06	L06BU	6"	6.625	500 psi / 35 bar	13789	7.1

M

Hingelok™ Couplings

Sizes: 1 1/2" to 6"

Materials: Malleable Iron

Pressure: Allows for working pressure ratings up to 300 psi

Details: The Patented Hingelok™ Coupling is specially designed for applications requiring a quick connection and/or disconnection of a pipe joint. The two coupling halves are hinged for ease of handling and are secured by a cam-action handle. Sizes 1 1/2" to 4" use toggle link plates and sizes 5" and 6" use a toggle bolt to attach the cam-action handle to the housings. A locking pin through the handle prevents accidental opening of the coupling.

Interchange Guide:

- Victaulic's #78
- Grinnell's #7003



HINGELOK™ COUPLING						
PART NO. w/EPDM SEAL	w/BUNA-N SEAL	NOMINAL SIZE (inches)	PIPE O.D. (inches)	MAX WORKING PRESSURE	MAX END LOAD (lbs)	APPROX WEIGHT EACH (lbs)
H315	H315BU	1 1/2"	1.900	300 psi / 20 bar	850	1.5
H32	H32BU	2"	2.375	300 psi / 20 bar	1329	2.0
H325	H325BU	2 1/2"	2.875	300 psi / 20 bar	2120	3.0
H33	H33BU	3"	3.500	300 psi / 20 bar	2886	3.8
H34	H34BU	4"	4.500	300 psi / 20 bar	4771	6.8
H36	H36BU	6"	6.625	300 psi / 20 bar	10341	12.7



Victaulic Groove End Fittings

- Sizes:** 2" to 6"
- Materials:** Ductile Iron
- Pressure:** Maximum working pressure up to 1000 psi / 70 bar
- Details:** These Grooved End Fittings are designed to provide minimum pressure drop and uniform strength. Interchangeable with Victaulic and Grinnell styles listed below.
- Interchange Guide:** See Below



90° ELBOW			
PART No.	NOMINAL SIZE	CENTRE TO END	APPROX. WEIGHT
L502	2"	3 1/4"	1.9lbs
L5025	2 1/2"	3 3/4"	3.1lbs
L503	3"	4 1/4"	4.7lbs
L5035	3 1/2"	4 1/2"	5.9lbs
L504	4"	5"	7.8lbs
L505	5"	5 1/2"	11.8lbs
L506	6"	6 1/2"	18.1lbs

Interchange Guide: • Victaulic's #10 • Grinnell's #7050



TEE			
PART No.	NOMINAL SIZE	CENTRE TO END	APPROX. WEIGHT
T602	2"	3 1/4"	2.9lb
T6025	2 1/2"	3 3/4"	4.9lbs
T603	3"	4 1/4"	7.2lbs
T6035	3 1/2"	4 1/2"	9.8lb
T604	4"	5"	12.3lbs
T605	5"	5 1/2"	21.8lbs
T606	6"	6 1/2"	26.8lbs

Interchange Guide: • Victaulic's #20 • Grinnell's #7060



ADAPTER NIPPLES - MALE NPT x GROOVED END			
PART No.	NOMINAL SIZE	CENTRE TO END	APPROX. WEIGHT
A712	2"	4"	1.2lbs
A7125	2 1/2"	4"	1.9lbs
A713	3"	4"	2.5lbs
A714	4"	6"	5.5lbs
A715	5"	6"	7.4lbs
A716	6"	6"	9.5lb

Interchange Guide: • Victaulic's #40 • Grinnell's #7081

GASKETS

Sizes: 1 1/2" to 8"

Compounds:

- EPDM
- Buna-N

Details:

- Use lubricant on gasket
- Check gasket colour code to ensure that it is recommended for the service intended
- Unless otherwise noted, all gaskets listings are based upon 38°C (100°F) max. temp. service conditions



GASKETS						
PART No.	SIZE RANGE	TEMP. CODE	COLOUR	COMPOUND	GENERAL SERVICE APPLICATIONS	
G150E	1 1/2"	-40C to +110C	Green	EPDM	Water, dilute acids, alkalines, salts and many chemical services not involving hydrocarbons, oils or gases. Air, (no oil vapours) temp. -40°C to 110°C (40°F to 230°F). Excellent oxidation resistance. NOT FOR USE WITH HYDROCARBONS	
G200E	2"	-40C to +110C	Green	EPDM		
G250E	2 1/2"	-40C to +110C	Green	EPDM		
G300E	3"	-40C to +110C	Green	EPDM		
G400E	4"	-40C to +110C	Green	EPDM		
G500E	5"	-40C to +110C	Green	EPDM		
G600E	6"	-40C to +110C	Green	EPDM		
G800E	8"	-40C to +110C	Green	EPDM		
G150T	1 1/2"	-20C to +82C	Orange	Buna-N		Petroleum products, vegetable oils, mineral oils and air contaminated with petroleum oils. Air, oil vapour, temp. -29°C to 66°C (-20°F to 150°F). NOT FOR USE IN HOT WATER SERVICES
G200T	2"	-20C to +82C	Orange	Buna-N		
G250T	2 1/2"	-20C to +82C	Orange	Buna-N		
G300T	3"	-20C to +82C	Orange	Buna-N		
G400T	4"	-20C to +82C	Orange	Buna-N		
G500T	5"	-20C to +82C	Orange	Buna-N		
G600T	6"	-20C to +82C	Orange	Buna-N		
G800T	8"	-20C to +82C	Orange	Buna-N		

Bolts: Heat treated, oval neck track head

Nuts: Heavy hex nuts of electroplate carbon steel

NUTS AND BOLTS	
PART No.	GROOVE LOCK BOLT DESCRIPTION
GLBLT38	3/8" x 2 1/4"
GLBLT50	1/2" x 3"
GLBLT62	5/8" x 3 1/4"
GLBLT75	3/4" x 4 1/2"
GLBLT87	7/8" x 5"

M

GEKA type Brass Quick Couplings

- Sizes:** 3/8" to 1 1/2"
- Compounds:** Brass
- Pressure:** Maximum working pressure 45 psi / 3 bar
- Details:** A cost effective way of transferring low pressure water



HOSE END	
PART NO.	SIZE
REHE038B	3/8"
REHE050B	1/2"
REHE075B	3/4"
REHE100B	1"
REHE125B	1 1/4"
REHE150B	1 1/2"



FEMALE HOSE END	
PART NO.	SIZE
REF038B	3/8"
REF050B	1/2"
REF075B	3/4"
REF100B	1"
REF125B	1 1/4"
REF150B	1 1/2"



BLANK CAP
PART NO.
RE BCB



GASKET
PART NO.
RESG

Lugged Water Couplings - King Shank Serrated Tail

Sizes: 1/2" to 4"

Materials: • Brass • Ductile Iron • Malleable Iron • 316 Stainless Steel • Polypropylene

Details: Suction and delivery hose couplings - BSP PI. parallel thread only



BRASS MALE		
PART NO.	SIZE	MATERIAL
KSM050B	1/2"	Brass
KSM075B	3/4"	Brass
KSM100B	1"	Brass
KSM125B	1 1/4"	Brass
KSM150B	1 1/2"	Brass
KSM200B	2"	Brass
KSM250B	2 1/2"	Brass
KSM300B	3"	Brass
KSM400B	4"	Brass



BRASS FEMALE		
PART NO.	SIZE	MATERIAL
KSF050B	1/2"	Brass
KSF075B	3/4"	Brass
KSF100B	1"	Brass
KSF125B	1 1/4"	Brass
KSF150B	1 1/2"	Brass
KSF200B	2"	Brass
KSF250B	2 1/2"	Brass
KSF300B	3"	Brass
KSF400B	4"	Brass



DUCTILE IRON MALE		
PART NO.	SIZE	MATERIAL
KSM125M	1 1/4"	Ductile Iron
KSM150M	1 1/2"	Ductile Iron
KSM200M	2"	Ductile Iron
KSM250M	2 1/2"	Ductile Iron
KSM300M	3"	Ductile Iron
KSM400M	4"	Ductile Iron



DUCTILE IRON FEMALE		
PART NO.	SIZE	MATERIAL
KSF125M	1 1/4"	Ductile Iron
KSF150M	1 1/2"	Ductile Iron
KSF200M	2"	Ductile Iron
KSF250M	2 1/2"	Ductile Iron
KSF300M	3"	Ductile Iron
KSF400M	4"	Ductile Iron

M

Water Couplings



STAINLESS STEEL HEXAGON MALE

PART NO.	SIZE	MATERIAL
KSM100SS	1"	Stainless Steel
KSM125SS	1 1/4"	Stainless Steel
KSM150SS	1 1/2"	Stainless Steel
KSM200SS	2"	Stainless Steel
KSM250SS	2 1/2"	Stainless Steel
KSM300SS	3"	Stainless Steel
KSM400SS	4"	Stainless Steel



STAINLESS STEEL LUG NUT FEMALE

PART NO.	SIZE	MATERIAL
KSF100SS	1"	Stainless Steel
KSF125SS	1 1/4"	Stainless Steel
KSF150SS	1 1/2"	Stainless Steel
KSF200SS	2"	Stainless Steel
KSF250SS	2 1/2"	Stainless Steel
KSF300SS	3"	Stainless Steel
KSF400SS	4"	Stainless Steel



RUBBER WASHER

PART NO.	SIZE
KRW5	3/8"
KRW10	1"
KRW15	1 1/4"
KRW20	1 1/2"
KRW25	2"
KRW30	2 1/2"
KRW35	3"
KRW40	4"
KRW50	5"
KRW60	6"
KRW80	8"



NEOPRENE WASHER

PART NO.	SIZE
KNW5	3/8"
KNW10	1"
KNW15	1 1/4"
KNW20	1 1/2"
KNW25	2"
KNW30	2 1/2"
KNW35	3"
KNW40	4"
KNW50	5"
KNW60	6"
KNW80	8"

M



LEATHER WASHER	
PART NO.	SIZE
KLW5	3/8"
KLW10	1"
KLW15	1 1/4"
KLW20	1 1/2"
KLW25	2"
KLW30	2 1/2"
KLW35	3"
KLW40	4"



POLYPROPYLENE URT FEMALE			
PART No.	SIZE	THREAD	MATERIAL
GEF300P	3"	URT	Polypropylene
GEF400P	4"	URT	Polypropylene

ALUMINIUM URT FEMALE			
PART No.	SIZE	THREAD	MATERIAL
GEF300A	3"	URT	Aluminium
GEF400A	4"	URT	Aluminium



POLYPROPYLENE URT MALE			
PART No.	SIZE	THREAD	MATERIAL
GEM300P	3"	URT	Polypropylene
GEM400P	4"	URT	Polypropylene

ALUMINIUM URT MALE			
PART No.	SIZE	THREAD	MATERIAL
GEM300A	3"	URT	Aluminium
GEM400A	4"	URT	Aluminium



URT CAPS			
PART No.	SIZE	THREAD	MATERIAL
GEBC300P	3"	URT	Polypropylene
GEBC400P	4"	URT	Polypropylene
GEBC300A	3"	URT	Aluminium
GEBC400A	4"	URT	Aluminium
GEBC300G	3"	URT	Gunmetal

“King” Combination Nipples

Hose nipples, made from tubular stock, to fit straight end hose. Threaded end, in all styles, has male NPT or BSPT thread. Combination nipples are recommended for low pressure discharge and suction service for compatible liquids. **Not for compressible products such as air or nitrogen on sizes 1 1/4” and above.** The working pressure of combination nipples will vary with the size and construction of the hose, the type and number of clamps used, clamp placement, proper installation of clamps, temperature and product being conveyed. In accordance with the RMA bulletin for oil suction and discharge hose, a coupled length of hose, in any size should be tested to 1.5 x the working pressure and held for 15 minutes without leaking or coupling movements. Consult Dixon for recommendations specific to the application, or refer to the pressure recommendations table in the technical section at the back of this catalogue. **“King” Combination Nipples are not recommended for steam service.**



PLATED STEEL BSPT THREAD

PART NO.	SIZE
STC10A	1”
STC15A	1 1/4”
STC20A	1 1/2”
STC25A	2”
STC30A	2 1/2”
STC35A	3”
STC40A	4”
STC50A	5”
STC60A	6”



PLATED STEEL NPT THREAD

PART NO.	SIZE
STC1	1/2”
STC5	3/4”
STC10	1”
STC15	1 1/4”
STC20	1 1/2”
STC25	2”
STC30	2 1/2”
STC35	3”
STC40	4”
STC50	5”
STC60	6”
STC80	8”
STC100	10”
STC120	12”



UNPLATED STEEL - GROOVED ENDS

PART NO.	SIZE
STV10	1”
STV15	1 1/4”
STV20	1 1/2”
STV25	2”
STV30	2 1/2”
STV35	3”
STV40	4”
STV50	5”
STV60	6”
STV80	8”
STV100	10”
STV120	12”

M



UNPLATED STEEL - BEVELLED ENDS	
PART NO.	SIZE
STB1	1/2"
STB5	3/4"
STB10	1"
STB15	1 1/4"
STB20	1 1/2"
STB25	2"
STB30	2 1/2"
STB35	3"
STB40	4"
STB50	5"
STB60	6"
STB80	8"
STB100	10"
STB120	12"

316 STAINLESS STEEL - BEVELLED ENDS	
PART NO.	SIZE
RSTB10	1"
RSTB15	1 1/4"
RSTB20	1 1/2"
RSTB25	2"
RSTB30	2 1/2"
RSTB35	3"
RSTB40	4"



PLATED STEEL FOR PLASTIC PIPES - NPT THREAD	
PART NO.	SIZE
SAP1	1/2"
SAP6	3/4"
SAP11	1"
SAP16	1 1/4"
SAP21	1 1/2"
SAP26	2"
SAP31	2 1/2"
SAP36	3"
SAP46	4"
SAP66	6"



316 STAINLESS STEEL - BSPT THREAD	
PART NO.	SIZE
RST10A	1"
RST15A	1 1/4"
RST20A	1 1/2"
RST25A	2"
RST35A	3"
RST40A	4"



316 STAINLESS STEEL - NPT THREAD	
PART NO.	SIZE
RST1	1/2"
RST5	3/4"
RST10	1"
RST15	1 1/4"
RST20	1 1/2"
RST25	2"
RST30	2 1/2"
RST35	3"
RST40	4"
RST50	5"
RST60	6"
RST80	8"

Water Couplings



BRASS - NPT THREAD	
PART NO.	SIZE
BST1	1/2"
BST5	3/4"
BST10	1"
BST15	1 1/4"
BST20	1 1/2"
BST25	2"
BST30	2 1/2"
BST35	3"
BST40	4"
BST50	5"



ALUMINIUM - NPT THREAD	
PART NO.	SIZE
AST1	1/2"
AST5	3/4"
AST10	1"
AST15	1 1/4"
AST20	1 1/2"
AST25	2"
AST30	2 1/2"
AST35	3"
AST40	4"
AST50	5"
AST60	6"



"TUFF-LITE" NYLON - NPT THREAD	
PART NO.	SIZE
THN15	1 1/4"
THN20	1 1/2"
THN25	2"
THN35	3"



"TUFF-LITE" POLYPROPYLENE - NPT THREAD	
PART NO.	SIZE
PPN44	1/2"
PPN66	3/4"
PPN88	1"
HB150	1 1/2"
HB200	2"
HB300	3"

M

"KING" STEEL HOSE MENDERS



PART NO.	SIZE	TYPE
KM21	1/4"	For 1 clamp each end
KM251	5/16"	For 1 clamp each end
KM41	1/2"	For 1 clamp each end
KM51	5/8"	For 1 clamp each end
KM61	3/4"	For 1 clamp each end
KM81	1"	For 1 clamp each end
KM101	1 1/4"	For 1 clamp each end
KM121	1 1/2"	For 1 clamp each end
KM42	1/2"	For 2 clamps each end
KM52	5/8"	For 2 clamps each end
KM62	3/4"	For 2 clamps each end
KM82	1"	For 2 clamps each end
KM102	1 1/4"	For 2 clamps each end
KM122	1 1/2"	For 2 clamps each end
KM162	2"	For 2 clamps each end

STEEL HOSE MENDERS



PART NO.	SIZE	MATERIAL
DMA	1/4"	Steel
DMB	3/8"	Steel
DM1	1/2"	Steel
DM5	5/8"	Steel
DM6	3/4"	Steel
DM11	1"	Steel
DM16	1 1/4"	Steel
DM18	1 3/8"	Steel
DM21	1 1/2"	Steel
DMXL21*	1 1/2"	Steel
DM26	2"	Steel
DMXL26*	2"	Steel
DM31	2 1/2"	Steel
DM36	3"	Steel
DM46	4"	Steel
DM51	5"	Steel
DM66	6"	Steel
DM86	8"	Steel
DM100	10"	Steel
DM120	12"	Steel
RDMA	1/4"	316 Stainless Steel
RDMB	3/8"	316 Stainless Steel
RDM1	1/2"	316 Stainless Steel
RDM6	3/4"	316 Stainless Steel
RDM11	1"	316 Stainless Steel
RDM16	1 1/4"	316 Stainless Steel
RDM21	1 1/2"	316 Stainless Steel
RDM26	2"	316 Stainless Steel
RDM36	3"	316 Stainless Steel
RDM46	4"	316 Stainless Steel

* XL series is extra long

"KING" BRASS HOSE MENDERS



PART NO.	SIZE	MATERIAL
BM15	3/16"	Brass
BM2	1/4"	Brass
BM25	5/16"	Brass
BM3	3/8"	Brass
BM4	1/2"	Brass
BM6	3/4"	Brass
BM8	1"	Brass

M

Water Couplings

Other sizes of 316 Stainless Steel Flanged Hose Spigots available on request.

Can also be produced with a collar to suit the "Boss" range of clamps.



Also Available in Swivel

SERIES FHS - WELDED FLANGED HOSE SPIGOTS

PART NO.	SIZE	DESCRIPTION	MATERIAL
50DFHT	1/2"	BS10TableD	Steel
75DFHT	3/4"	BS10TableD	Steel
100DFHT	1"	BS10TableD	Steel
125DFHT	1 1/4"	BS10TableD	Steel
150DFHT	1 1/2"	BS10TableD	Steel
200DFHT	2"	BS10TableD	Steel
250DFHT	2 1/2"	BS10TableD	Steel
300DFHT	3"	BS10TableD	Steel
400DFHT	4"	BS10TableD	Steel
500DFHT	5"	BS10TableD	Steel
600DFHT	6"	BS10TableD	Steel
800DFHT	8"	BS10TableD	Steel
1000DFHT	10"	BS10TableD	Steel
1200DFHT	12"	BS10TableD	Steel
400EFHT	4"	BS10TableE	Steel
500EFHT	5"	BS10TableE	Steel
600EFHT	6"	BS10TableE	Steel
800EFHT	8"	BS10TableE	Steel
1000EFHT	10"	BS10TableE	Steel
1200EFHT	12"	BS10TableE	Steel
50ASAFHT	1/2"	ASA150	Steel
75ASAFHT	3/4"	ASA150	Steel
100ASAFHT	1"	ASA150	Steel
125ASAFHT	1 1/4"	ASA150	Steel
150ASAFHT	1 1/2"	ASA150	Steel
200ASAFHT	2"	ASA150	Steel
250ASAFHT	2 1/2"	ASA150	Steel
300ASAFHT	3"	ASA150	Steel
400ASAFHT	4"	ASA150	Steel
500ASAFHT	5"	ASA150	Steel
600ASAFHT	6"	ASA150	Steel
800ASAFHT	8"	ASA150	Steel
1000ASAFHT	10"	ASA150	Steel
1200ASAFHT	12"	ASA150	Steel
50NP16FHT	1/2"	BS4504PN16	Steel
75NP16FHT	3/4"	BS4504PN16	Steel
100NP16FHT	1"	BS4504PN16	Steel
125NP16FHT	1 1/2"	BS4504PN16	Steel
150NP16FHT	1 1/2"	BS4504PN16	Steel
200NP16FHT	2"	BS4504PN16	Steel
250NP16FHT	2 1/2"	BS4504PN16	Steel
300NP16FHT	3"	BS4504PN16	Steel
400NP16FHT	4"	BS4504PN16	Steel
500NP16FHT	5"	BS4504PN16	Steel
600NP16FHT	6"	BS4504PN16	Steel
800NP16FHT	8"	BS4504PN16	Steel
1000NP16FHT	10"	BS4504PN16	Steel
1200NP16FHT	12"	BS4504PN16	Steel

SERIES FHS - SS FLANGED HOSE SPIGOTS

PART NO.	SIZE	DESCRIPTION	MATERIAL
100DFHTSS	1"	BS10TableD	316 Stainless Steel
150DFHTSS	1 1/2"	BS10TableD	316 Stainless Steel
200DFHTSS	2"	BS10TableD	316 Stainless Steel
250DFHTSS	2 1/2"	BS10TableD	316 Stainless Steel
300DFHTSS	3"	BS10TableD	316 Stainless Steel
400DFHTSS	4"	BS10TableE	316 Stainless Steel
100ASAFHTSS	1"	ASA150	316 Stainless Steel
150ASAFHTSS	1 1/2"	ASA150	316 Stainless Steel
200ASAFHTSS	2"	ASA150	316 Stainless Steel
250ASAFHTSS	2 1/2"	ASA150	316 Stainless Steel
300ASAFHTSS	3"	ASA150	316 Stainless Steel
400ASAFHTSS	4"	ASA150	316 Stainless Steel
100NP16SS	1"	BS4504PN16	316 Stainless Steel
150NP16SS	1 1/2"	BS4504PN16	316 Stainless Steel
200NP16SS	2"	BS4504PN16	316 Stainless Steel
250NP16SS	2 1/2"	BS4504PN16	316 Stainless Steel
300NP16SS	3"	BS4504PN16	316 Stainless Steel
400NP16SS	4"	BS4504PN16	316 Stainless Steel



M

Crimp Style King Combination Nipples

SAFETY ALERT

Only use the crimp style shanks with the crimp style sleeves and ferrules.
Due to differences in dimensions and tolerances for safety reasons, do not interchange other manufacturer's products with Dixon products.



NPT MALE THREADED END		
PLATED CARBON STEEL PART NO.	316 STAINLESS STEEL PART NO.	HOSE ID
ST10CS	RST10CS	1"
ST20CS	RST20CS	1½"
ST25CS	RST25CS	2"
ST35CS	RST35CS	3"
ST40CS	RST40CS	4"
ST60CS	RST60CS	6"



VICTAULIC GROOVED END		
PLATED CARBON STEEL PART NO.	316 STAINLESS STEEL PART NO.	HOSE ID
STV10CS	RSTV10CS	1"
STV20CS	RSTV20CS	1½"
STV25CS	RSTV25CS	2"
STV35CS	RSTV35CS	3"
STV40CS	RSTV40CS	4"
STV60CS	RSTV60CS	6"



BEVELED END		
PLATED CARBON STEEL PART NO.	316 STAINLESS STEEL PART NO.	HOSE ID
STB10CS	RSTB10CS	1"
STB20CS	RSTB20CS	1½"
STB25CS	RSTB25CS	2"
STB35CS	RSTB35CS	3"
STB40CS	RSTB40CS	4"
STB60CS	RSTB60CS	6"



CRIMP STYLE SLEEVES

CARBON STEEL PART NO.	304 STAINLESS STEEL PART NO.	ALUMINIUM PART NO.	HOSE ID	HOSE OD	
				FROM	TO
CS100-1CS	CS100-1SS	CS100-1AL	1"	30.56	31.75
CS100-2CS	CS100-2SS	CS100-2AL		32.15	33.34
CS100-3CS	CS100-3SS	CS100-3AL		33.73	34.93
CS100-4CS	CS100-4SS	CS100-4AL		35.32	36.51
CS100-5CS	CS100-5SS	CS100-5AL		36.91	38.10
CS100-6CS	CS100-6SS	CS100-6AL		38.50	39.69
CS100-7CS	CS100-7SS	CS100-7AL		40.08	41.28
CS100-8CS	CS100-8SS	CS100-8AL		41.67	42.86
CS100-9CS	CS100-9SS	CS100-9AL		43.26	44.45
CS100-10CS	CS100-10SS	CS100-10AL		44.85	46.04
CS150-1CS	CS150-1SS	CS150-1AL	1½"	41.67	42.86
CS150-2CS	CS150-2SS	CS150-2AL		43.26	44.45
CS150-3CS	CS150-3SS	CS150-3AL		44.85	46.04
CS150-4CS	CS150-4SS	CS150-4AL		46.43	47.63
CS150-5CS	CS150-5SS	CS150-5AL		48.02	49.21
CS150-6CS	CS150-6SS	CS150-6AL		49.61	50.80
CS150-7CS	CS150-7SS	CS150-7AL		51.20	52.39
CS150-8CS	CS150-8SS	CS150-8AL		52.78	53.98
CS150-9CS	CS150-9SS	CS150-9AL		54.37	55.56
CS150-10CS	CS150-10SS	CS150-10AL		55.96	57.15
CS150-11CS	CS150-11SS	CS150-11AL		57.55	58.74
CS150-12CS	CS150-12SS	CS150-12AL		59.13	60.33
CS200-1CS	CS200-1SS	CS200-1AL	2"	55.96	57.15
CS200-2CS	CS200-2SS	CS200-2AL		57.55	58.74
CS200-3CS	CS200-3SS	CS200-3AL		59.13	60.33
CS200-4CS	CS200-4SS	CS200-4AL		60.72	61.91
CS200-5CS	CS200-5SS	CS200-5AL		62.31	63.50
CS200-6CS	CS200-6SS	CS200-6AL		63.90	65.09
CS200-7CS	CS200-7SS	CS200-7AL		65.48	66.68
CS200-8CS	CS200-8SS	CS200-8AL		67.07	68.26
CS200-9CS	CS200-9SS	CS200-9AL		68.66	69.85
CS200-10CS	CS200-10SS	CS200-10AL		70.25	71.44
CS200-11CS	CS200-11SS	CS200-11AL		71.83	73.03
CS200-12CS	CS200-12SS	CS200-12AL		73.42	74.61
CS300-1CS	CS300-1SS	CS300-1AL	3"	81.36	82.55
CS300-2CS	CS300-2SS	CS300-2AL		82.95	84.14
CS300-3CS	CS300-3SS	CS300-3AL		84.53	85.73
CS300-4CS	CS300-4SS	CS300-4AL		86.12	87.31
CS300-5CS	CS300-5SS	CS300-5AL		87.71	88.90
CS300-6CS	CS300-6SS	CS300-6AL		89.30	90.49
CS300-7CS	CS300-7SS	CS300-7AL		90.88	92.08
CS300-8CS	CS300-8SS	CS300-8AL		92.47	93.66
CS300-9CS	CS300-9SS	CS300-9AL		94.06	95.25
CS300-10CS	CS300-10SS	CS300-10AL		95.65	96.84
CS300-11CS	CS300-11SS	CS300-11AL		97.23	98.43
CS300-12CS	CS300-12SS	CS300-12AL		98.82	100.01
CS300-13CS	CS300-13SS	CS300-13AL		100.41	101.60
CS300-14CS	CS300-14SS	CS300-14AL		102.00	103.19
CS300-15CS	CS300-15SS	CS300-15AL		103.58	104.78
CS300-16CS	CS300-16SS	CS300-16AL	105.17	106.36	
CS400-1CS	CS400-1SS	CS400-1AL	4"	106.76	107.95
CS400-2CS	CS400-2SS	CS400-2AL		108.35	109.54
CS400-3CS	CS400-3SS	CS400-3AL		109.93	111.13
CS400-4CS	CS400-4SS	CS400-4AL		111.52	112.71
CS400-5CS	CS400-5SS	CS400-5AL		113.11	114.30
CS400-6CS	CS400-6SS	CS400-6AL		114.70	115.89
CS400-7CS	CS400-7SS	CS400-7AL		116.28	117.48
CS400-8CS	CS400-8SS	CS400-8AL		117.87	119.06
CS400-9CS	CS400-9SS	CS400-9AL		119.46	120.65
CS400-10CS	CS400-10SS	CS400-10AL		121.05	122.24
CS400-11CS	CS400-11SS	CS400-11AL		122.63	123.83
CS400-12CS	CS400-12SS	CS400-12AL		124.22	125.41
CS400-13CS	CS400-13SS	CS400-13AL	125.81	127.00	
CS400-14CS	CS400-14SS	CS400-14AL	127.40	128.59	
CS400-15CS	CS400-15SS	CS400-15AL	128.98	130.18	
CS400-16CS	CS400-16SS	CS400-16AL	130.57	131.76	
CS600-1CS	CS600-1SS	CS600-1AL	6"	160.73	163.51
CS600-2CS	CS600-2SS	CS600-2AL		163.91	166.69
CS600-3CS	CS600-3SS	CS600-3AL		167.08	169.86
CS600-4CS	CS600-4SS	CS600-4AL		170.26	173.04
CS600-5CS	CS600-5SS	CS600-5AL		173.43	176.39
CS600-6CS	CS600-6SS	CS600-6AL		176.61	179.39
CS600-7CS	CS600-7SS	CS600-7AL		179.78	182.56
CS600-8CS	CS600-8SS	CS600-8AL		182.96	185.74
CS600-9CS	CS600-9SS	CS600-9AL		186.13	188.91

SAFETY ALERT

Only use the crimp style shanks with the crimp style sleeves and ferrules.

Due to differences in dimensions and tolerances for safety reasons, do not interchange other manufacturer's products with Dixon products.

M



CRIMP STYLE FERRULES

CARBON STEEL PART NO.	304 STAINLESS STEEL PART NO.	HOSE ID	HOSE OD	
			FROM	TO
CF100-1CS	CF100-1SS	1"	30.56	31.75
CF100-2CS	CF100-2SS		32.15	33.34
CF100-CS	CF100-3SS		33.73	34.93
CF100-4CS	CF100-4SS		35.32	36.51
CF100-5CS	CF100-5SS		36.91	38.10
CF100-6CS	CF100-6SS		38.50	39.69
CF100-7CS	CF100-7SS		40.08	41.28
CF100-8CS	CF100-8SS		41.67	42.86
CF100-9CS	CF100-9SS		43.26	44.45
CF100-10CS	CF100-10SS		44.85	46.04
CF150-1CS	CF150-1SS	1½"	41.67	42.86
CF150-2CS	CF150-2SS		43.26	44.45
CF150-3CS	CF150-3SS		44.85	46.04
CF150-4CS	CF150-4SS		46.43	47.63
CF150-5CS	CF150-5SS		48.02	49.21
CF150-6CS	CF150-6SS		49.61	50.80
CF150-7CS	CF150-7SS		51.20	52.39
CF150-8CS	CF150-8SS		52.78	53.98
CF150-9CS	CF150-9SS		54.37	55.56
CF150-10CS	CF150-10SS		55.96	57.15
CF150-11CS	CF150-11SS		57.55	58.74
CF150-12CS	CF150-12SS		59.13	60.33
CF200-1CS	CF200-1SS	2"	55.96	57.15
CF200-2CS	CF200-2SS		57.55	58.74
CF200-3CS	CF200-3SS		59.13	60.33
CF200-4CS	CF200-4SS		60.72	61.91
CF200-5CS	CF200-5SS		62.31	63.50
CF200-6CS	CF200-6SS		63.90	65.09
CF200-7CS	CF200-7SS		65.48	66.68
CF200-8CS	CF200-8SS		67.07	68.26
CF200-9CS	CF200-9SS		68.66	69.85
CF200-10CS	CF200-10SS		70.25	71.44
CF200-11CS	CF200-11SS		71.83	73.03
CF200-12CS	CF200-12SS		73.42	74.61
CF300-1CS	CF300-1SS	3"	81.36	82.55
CF300-2CS	CF300-2SS		82.95	84.14
CF300-3CS	CF300-3SS		84.53	85.73
CF300-4CS	CF300-4SS		86.12	87.31
CF300-5CS	CF300-5SS		87.71	88.90
CF300-6CS	CF300-6SS		89.30	90.49
CF300-7CS	CF300-7SS		90.88	92.08
CF300-8CS	CF300-8SS		92.47	93.66
CF300-9CS	CF300-9SS		94.06	95.25
CF300-10CS	CF300-10SS		95.65	96.84
CF300-11CS	CF300-11SS		97.23	98.43
CF300-12CS	CF300-12SS		98.82	100.01
CF300-13CS	CF300-13SS		100.41	101.60
CF300-14CS	CF300-14SS		102.00	103.19
CF300-15CS	CF300-15SS		103.58	104.78
CF300-16CS	CF300-16SS		105.17	106.36
CF400-1CS	CF400-1SS	4"	106.76	107.95
CF400-2CS	CF400-2SS		108.35	109.54
CF400-3CS	CF400-3SS		109.93	111.13
CF400-4CS	CF400-4SS		111.52	112.71
CF400-5CS	CF400-5SS		113.11	114.30
CF400-6CS	CF400-6SS		114.70	115.89
CF400-7CS	CF400-7SS		116.28	117.48
CF400-8CS	CF400-8SS		117.87	119.06
CF400-9CS	CF400-9SS		119.46	120.65
CF400-10CS	CF400-10SS		121.05	122.24
CF400-11CS	CF400-11SS		122.63	123.83
CF400-12CS	CF400-12SS		124.22	125.41
CF400-13CS	CF400-13SS		125.81	127.00
CF400-14CS	CF400-14SS		127.40	128.59
CF400-15CS	CF400-15SS		128.98	130.18
CF400-16CS	CF400-16SS		130.57	131.76
CF600-1CS	CF600-1SS	6"	160.73	163.51
CF600-2CS	CF600-2SS		163.91	166.69
CF600-3CS	CF600-3SS		167.08	169.86
CF600-4CS	CF600-4SS		170.26	173.04
CF600-5CS	CF600-5SS		173.43	176.39
CF600-6CS	CF600-6SS		176.61	179.39
CF600-7CS	CF600-7SS		179.78	182.56
CF600-8CS	CF600-8SS		182.96	185.74
CF600-9CS	CF600-9SS		186.13	188.91

SAFETY ALERT

Only use the crimp style shanks with the crimp style sleeves and ferrules.

Due to differences in dimensions and tolerances for safety reasons, do not interchange other manufacturer's products with Dixon products.

Washdown Guns

- Manufactured from high quality brass & stainless steel components
- Works with effortless one hand operation
- Automatic shut off valve provides economical water consumption
- Trigger latching mechanism keeps nozzle open reducing hand fatigue
- Thick rubber coat protects against cold, heat and impact
- 1/2" BSP threaded inlet
- Flow Capacity: 25/L min @ 500 kpa
- 6.6 GPM @72psi
- Max. Operating Pressure: 2400 kpa (300psi)
- Blue Rubber Cover



FLOWBOSS WASHDOWN GUN

PART NO.

FLOBOSS-050



BRASS TAILS NPT THREAD

PART NO.

SIZE

BN44
BN64

1/2" Thread x 1/2" Hosetail
1/2" Thread x 3/4" Hosetail



INSULATED WATER NOZZLES	
PART NO.	
SN75	

- Heavy duty brass valve and adjusting nut
- Hold open clip locks any spray pattern
- Chrome plated all zinc body
- Industrial strength nylon handle
- Rubber head guard
- Hot water up to 82°C (180°F)
- Threaded Female GHT supplied with Female NPT adapter



PISTOL-GRIP WATER NOZZLES	
PART NO.	
CSN75	

- Heavy duty all zinc metalised body
- Clip locks any spray pattern
- Easy squeeze on/off lever
- All brass valve stem and adjusting nut
- Stainless Steel spring with lifetime pack
- Threaded Female GHT supplied with female NPT adapter



SOLID BRASS FULL SIZE NOZZLE	
PART NO.	
BTN75	

- Thread 3/4" BSP female



MALE GHT x FEMALE NPT - TO SUIT ABOVE NOZZLES	
PART NO.	SIZE
BA794	GHT x 1/2"
BA796	GHT x 3/4"
FM1076	GHT x 1"

M

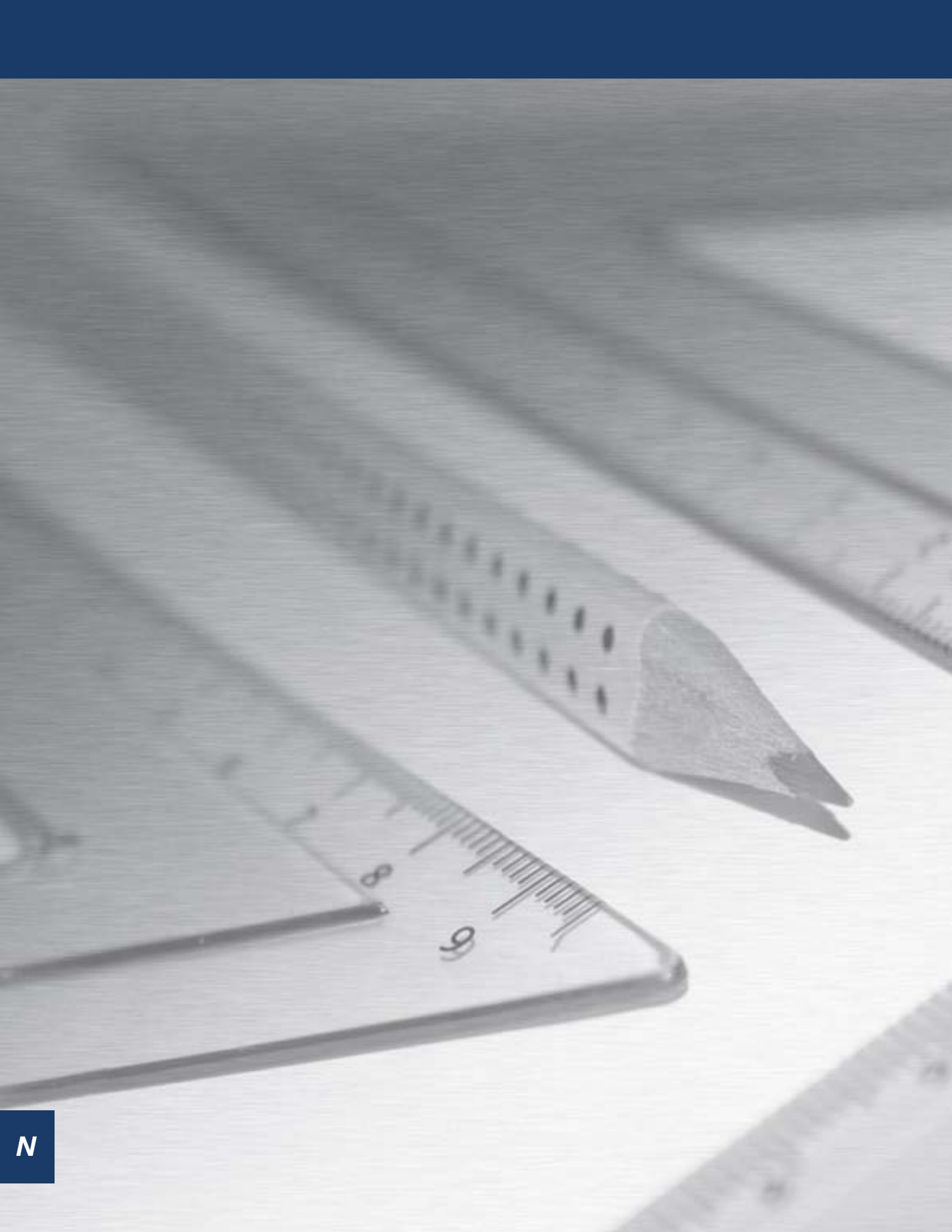

N

Technical & Safety Information

Hose & Hose Coupling Safety Information	444-445
S.T.A.M.P.E.D	446
B.E.S.A.F.E	447
Hose Assembling, Installation & Safety	448-453
Hose & Coupling Pressure Recommendations.....	454-458
Corrosion Resistance Guide.....	459-464
Measurement & Conversion Information	465-468
Coupling Flange & Thread Information	469-479
Crimp Recommendations	480-487
Valve Information.....	488-494
BPE Technical Information	495-498
Regulations: OSHA & MSHA.....	499-500
Fluid Compatibility Guide.....	500-501
Glossary of Terms	502-508
Dixon Terms & Conditions	509

Hose and Hose Coupling Safety

“The very properties that make compressed gases useful in almost every area of modern life can also make them dangerous when mishandled. Years of experience with compressed gases have led to practices and equipment which, if employed, result in complete safety.”**

Dixon hose couplings have been carefully engineered to meet specific requirements. If hose or couplings are not used in correct applications or are incorrectly applied, accidents and downtime can result. It is up to the end user to inform the distributor of the application and pressures involved when ordering hose assemblies and it is up to the distributor to supply the right hose and coupling for that application. When in doubt, Dixon is here to help you with a proper coupling recommendation.

1. Air hose couplings

This form of energy can be one of the most dangerous because it is used in so many applications and, when mishandled, can have more serious results than fluids. Air, as a gas, is compressible (fluids press only against hose or vessel walls and lose little volume under pressure). When pressurised air releases suddenly, it does so with explosive force and can cause rapid hose whip, which can do serious physical harm to personnel or damage to nearby objects. This is why the selection of proper hose and couplings for air lines is so important, along with their proper installation and maintenance. Never take for granted that a coupling is installed properly or a clamp fully tightened on an air hose - check it regularly and use safety devices (see paragraph 4).

2. Steam and gas

The same rules apply for steam and gas, but, because these are inherently more hazardous materials, personnel tend to treat hose and couplings on these lines with more respect and care. Checking clamp tightness is very important with steam hose, where it is not unusual for clamps to loosen in service, in which case they must be retightened! Safety devices should also be used (see paragraph 4).

3. Fluid hose couplings

Again, nothing should be taken for granted - in particular, check clamps for tightness each time the lines are used - especially when petroleum products or other hazardous liquids are involved. Large diameter hose, when suspended, can also be quite dangerous if it drops unexpectedly due to a coupling “pull-out” or sudden disconnection. A heavy fitting or clamp, plus the weight of the hose itself falling from any significant height, can cause injuries or damage. Be sure to use safety devices (see paragraph 4).

4. All hose assemblies

All hose assemblies should be treated with respect as potential hazards. Worn-out fittings should be replaced. Retaining devices such as clips, cables or chains should be used. Clamps should be checked regularly. Under no circumstances should any coupling be disconnected while under pressure, unless the coupling is specifically designed to do so. Disconnecting couplings under pressure could result in serious injury or death, and destruction of property and equipment.

**“Handbook of Compressed Gases”

General Safety Information

Pressure Ratings

Pressure ratings for couplings, as stated in this catalogue, are based upon ambient temperature (21°C or 70°F) applications with true hose I.D., new Dixon supplied couplings, new Dixon supplied clamps, new quality hose, and proper installation by a qualified assembler using Dixon procedures and equipment. In addition, temperature can affect coupling retention. For temperatures other than ambient (21°C or 70°F) contact the hose manufacturer or call Dixon.

Product Selection

Many of the products in this catalogue are used in hose assemblies in a variety of applications. The safety of any hose assembly rests on the proper selection, installation, testing and use of each product. The safe use of any product in this catalogue is dependent upon the correct selection of the hose, fittings and method of attachment. To ensure such a proper selection, the user must inform the distributor of the application and pressure involved when ordering hose assemblies. The use of S.T.A.M.P.E.D. (Size, Temperature, Application, Media, Pressure, Ends, Dixon) will help in the proper selection of hose assembly components (see next page). The selection of couplings and clamping devices is the responsibility of the purchaser or user, based upon the hose manufacturer's recommendations. If the purchaser or user is uncertain about the use or application of a product, Dixon stands ready to provide information, including test results (if available), coupling and clamping recommendations and other data to help resolve those matters.

Installation

To achieve a safe and reliable assembly, proper installation procedures must be followed. Each component of the assembly has a part in determining these procedures. The purchaser or user must follow proper procedures.

If the purchaser or user has any questions regarding installation, please contact Dixon.

Testing

Dixon recommends that all hose assemblies be tested in accordance with the hose manufacturer's recommendations.

Re-testing and inspection

Dixon recommends inspection and re-testing of hose assemblies on a regular and consistent basis in accordance with the hose manufacturer's recommendations. The application determines the regularity of the inspection and retesting schedule. Any worn-out fittings, damaged hoses or missing safety devices should be replaced immediately. Bolt-style clamps must be checked and retightened on a regular and consistent basis.

Proper selection, care, use and maintenance of hose couplings and accessory items

All hose assemblies should be viewed as potential hazards. This document is designed to inform and educate anyone who manufactures, specifies, supplies, purchases, assembles, uses, maintains or tests any hose assembly or its component parts. The proper selection and maintenance of hose, couplings, attachment devices and accessories are imperative. It is the end users responsibility to identify to the distributor the application and any special conditions that the hose assembly must meet. It is the distributors responsibility to supply the proper assembly for the intended application. Accidents and down time may occur if hose assemblies are not properly selected for the specific application. The performance and safety of the assembly is affected by the quality of the individual components. The use of the acronym S.T.A.M.P.E.D. (Size, Temperature, Application, Media, Pressure, Ends, Dixon) will help in the proper selection of the hose assembly components (see following page).

WARNING!

Failure to use these procedures can result in serious injury or death, and destruction of property and equipment.

If anyone is uncertain about the use or application of a product, Dixon can provide test results, coupling and clamping recommendations and other data to help resolve those matters. Please call Dixon.



S.T.A.M.P.E.D.

When fabricating and specifying hose assemblies ask the following questions:

- Size:** What is the I.D. (Inside Diameter) of the hose? What is the O.D. (Outside Diameter) of both ends of the hose? What is the overall length of the assembly required?
- Temperature:** What is the temperature range of the media (product) that is flowing through the hose assembly? What is the temperature range of the environment that surrounds the outside of the hose assembly?
- Application:** How is the hose assembly actually being used? Is it a pressure application? Is it a vacuum (suction) application? Is it a gravity flow application? Are there any special requirements that the hose assembly is expected to perform? Is the hose being used in a horizontal or vertical position? Are there any pulsations or vibrations acting on the hose assembly?
- Media:** What is the media/material that is flowing through the hose assembly? Being specific is critical. Check for: Abrasive materials, chemical compatibility, etc..
- Pressure:** What is the maximum pressure including surges (or, maximum vacuum) that this hose assembly will be subjected to? Always rate the maximum working pressure of your hose assembly by the lowest rated component in the system.
- Ends:** What couplings have been requested by the user? Are they the proper fittings for the application and hose selected?
- Dixon:** Dixon recommends that, based on the hose, fittings and attachment method used, all assemblies be permanently marked with the designed working pressure and intended media. Do not use other manufacture's fittings or ferrules with Dixon products due to the differences in dimensions and tolerances. We also recommend that all hose assemblies be tested frequently.

Be Safe: Any questions on application, use or assembly please call Dixon.

B.E.S.A.F.E.

We encourage you to share this information with anyone who may be effected by the selection, installation, maintenance or use of any hose assembly. Always use quality products to B.E.S.A.F.E.

Hose assemblies must be inspected prior to each use. Worn out fittings, attachment devices, hose and accessory items must be replaced. Retaining devices (safety devices) such as clips, cables or chains must be used. Clamps must be checked regularly to the specified torque found in the Dixon literature. Under no circumstance should any coupling be disconnected while under pressure unless the coupling is specifically designed to do so. Disconnecting couplings under pressure could result in serious injury or death, and destruction to property and equipment.

For all hose assemblies in use:

Beware

hose assemblies when used improperly or in the wrong application can be dangerous. The maximum working pressure shown on the hose is not an indication of the working pressure of the assembly. Based on the hose, fittings and attachment method used all assemblies should be permanently marked with the designed working pressure and the intended media. The assembly working pressure should be permanently displayed. Hose assemblies must be used for the intended service only. Never alter manufactured product or substitute component parts.

Eliminate

hazardous conditions by inspecting, maintaining and testing hose assemblies. Dixon recommends that all hose assemblies are tested in accordance with the hose manufacturer's specifications. The application determines the regularity of the re-testing schedule.

Secure

and inspect hose, fittings, clamping devices and safety accessories before each use. Never take for granted that the coupling or attachment devices are properly installed.

Always

inspect and re-tighten the bolts of any bolt style clamping device to the manufacturer's torque specifications.

Fittings

hose and clamping devices that are worn out or damaged must be removed from service.

Educate

your employees about the proper use, care and potential hazards of hose assemblies. Take advantage of Dixon's free Hose Assembly Safety Programme and the follow up Training Seminar to aid you in setting up your own inspection programme. Any questions on applications, use or assembly call our technical support team.

Dixon Hose Assembling

To provide a complete service to its customers Dixon has made considerable investment in its extensive in-house hose assembling capabilities, under pinned by a traceable Quality System in accordance with BSEN ISO 9001:2008 and compliance with PED 97/23/EC. The capability is supported by a huge inventory of couplings to produce hose assemblies utilising the following methods:

Rubber, PTFE* and Composite**

- Internal Expansion (IX) 25mm to 305mm nominal bore
- External Crimp (EC) 6mm to 102mm nominal bore
- External Swage (ES) 25mm to 102mm nominal bore

* EC only, **EC & ES only

Rubber and PVC

- Heavy Duty Double Bolt Clamps
- Band & Pre-formed Band Clamps
- Heavy Duty T-Bolt Clamps
- Hi-Torque Clamps
- Compression Rings
- BSEN 14420-3:2004 Safety Clamps (formerly DIN 2817 etc)

Metal

- Welding procedures are in accordance with ASME IX, and BSEN 288
- Welders Qualifications to ASME IX and BSEN 287

Test procedures and additional services

Our pressure testing facilities include:

- Pneumatic Leak Test (Air under Water)
- Hydrostatic Proof and Burst tests up to 380 bar (5510 psig)
- Hydrostatic Proof and Burst test certification can be supplied with a Chart Recorder read-out if requested at time of order placement
- Assemblies can also be Hydrostatically tested using de-mineralised water (Maximum Chloride content of 30mg/l) when requested
- Liquid Penetrant Inspection to ASME V Article 6 & ASME B31.3 Table 341.3.2
- Liquid Penetrant Technicians qualified to PCN Level 2
- Sub-Contract X-Ray in accordance with ASME V Article 6 with acceptance level to ASME B31.3 Table 341.3.2
- Endoscope

Registered supplier to the Uk Ministry of Defence.

Installation & Safety

When installed correctly within the design parameters of the hose to be used, Stainless Steel hose assemblies can give many years of satisfactory life. To help maximise the working life the following rules should be observed.

Torque - Stainless Steel hose assemblies should never be subject to torque.

Hose is subjected to torque by:

1. Twisting during installation. This can be minimised by the use of a swivel joint at one end, where the fixed fitting is tightened up first. Two spanners should be used on union fittings.
2. Twisting when flexed. The hose should be installed so that flexing takes place in one plane only and the direction of motion must be perpendicular to the centre line of the hose. Pipework must be anchored and guided at each change of direction where a hose is used to absorb pipework movement.

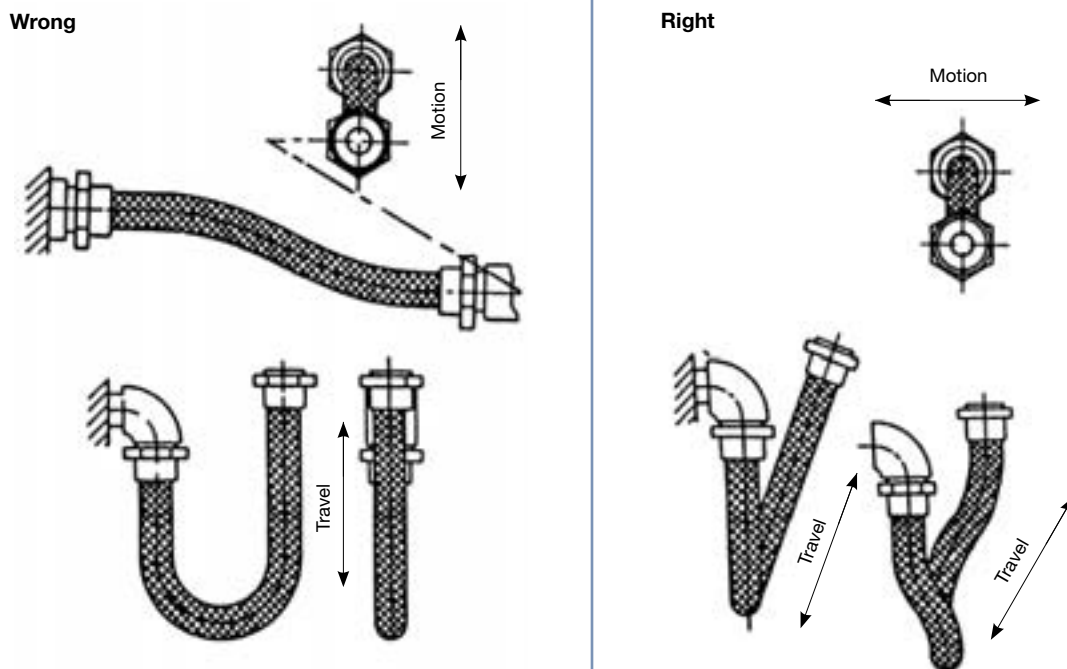

Rubbing - Any signs of external damage should cause the hose to be replaced. Damage to the braid will cause the pressure capacity of the hose to be compromised, possibly endangering personnel.

Pressure - Always refer to the maximum working pressure of the hose before installation. Always take into account the other working conditions such as temperature and pulsation.

Pulsation or Shock Pressures - These can be caused by the fast opening or closing of valves etc. and can cause premature failure through metal fatigue. Where this cannot be avoided the maximum working pressure of the hose should be reduced by 50%. Installation should be in a straight line with no slack on the braid.

Installation & Safety

Small Radii - Small radii should be avoided and the minimum centre line bend radius of the hose should always be observed. Be aware of the different bend radii for dynamic (i.e. constantly moving) and static (i.e. anti vibration) applications. The use of Parrap hose or solid elbows should be considered. If the application causes the hose to flex below the minimum bend radius near the ferrule, the use of a hose 'bend limiter' can be considered.

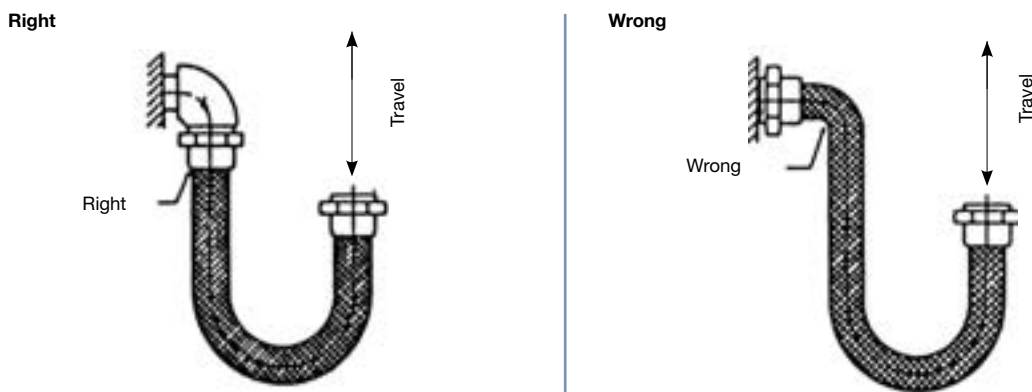

Flow Velocity - The convolutions can effect high flow velocities in one of two ways:

1. Turbulence. Velocities above 150 Ft/Sec for Gas or 75 Ft/Sec for Liquid can cause turbulence within the hose convolutions leading to metal fatigue. To overcome this, the use of the next size of hose, with or without a liner, can be effective. For hoses bent through 90° the above flows should be reduced by 50%, for 45° reduce by 25%.
2. Pressure Loss. As a rough guide it can be assumed that the pressure loss in a Convoluted Stainless Steel hose is twice that for new, welded steel pipe. This means that an increase in the bore size of 15% will reduce the pressure loss to that of the steel pipe.

Temperature:

When operating at elevated temperatures, a 'correction' factor should be applied to reflect the changed state of the hose material.

STAINLESS STEEL CORE GRADE 321 (1.4541)										
TEMPERATURE °C	-200	-150	-100	-50	0	50	100	150	200	250
FACTOR	1	1	1	1	1	0.93	0.83	0.78	0.74	0.70
TEMPERATURE °C	300	350	400	450	500	550	600	650		
FACTOR	0.66	0.64	0.62	0.60	0.59	0.58	Enquire	Enquire		

STAINLESS STEEL CORE GRADE 316 (1.4404)										
TEMPERATURE °C	-200	-150	-100	-50	0	50	100	150	200	250
FACTOR	1	1	1	1	1	0.90	0.73	0.67	0.61	0.58
TEMPERATURE °C	300	350	400	450	500	550	600	650		
FACTOR	0.53	0.51	0.50	0.49	0.47	0.47	Enquire	Enquire		

The above information is intended as a guide only, and as such the above specifications cannot be held to be mandatory. Dixon reserves the right to change and modify designs and specification without notice.

Pressure Equipment Directive 97/23/EC

The Pressure Equipment Directive 97/23/EC was embraced by the European Parliament and the Council of Ministers on 29 May 1997, enforced a further 2 years later on 29 November 1999 but with a 3 year grace, whereby compliance to its requirements were elective until 29 May 2002.

Failure to comply could result in prosecution by way of a fine, prison sentence or both.

On the whole the PED is legislation across the European Environment Agency (EEA), which requires that all pressure equipment must be fully compliant with regards to particular aspects such as material selection, design, manufacturing techniques, personnel qualification, testing requirements, product marking and user liability.

The Directive covers pressure equipment and assemblies with a maximum allowable pressure PS greater than 0.5 bar and includes such equipment as reaction vessels, industrial pipe-work, pressurised storage containers, heat exchangers, pressure accessories and safety devices. The PED's interpretation of an assembly being several pieces of pressure equipment assembled to form an integrated system.

PED accreditation, where applicable, allows for the active placing of the CE mark on pressure equipment and is a given passport to free trade within the EEA, without the need for statutory inspection by current Member States.

As a result, Dixon Group Europe have revised their manufacturing methodology and integrated an already efficient ISO 9001 quality management system with the Essential Safety Requirements of the PED, accredited by Lloyds Register, Notified Body Number 0038.

For further information on how this can benefit your business, please contact us on 01772 323529

Hose & Coupling Site Safety Survey

At Dixon we recognise the need for onsite safety and how understanding the importance this holds and helps generate a stronger relationship with your customer.

As a result Dixon now offers hose and coupling safety surveys.

Today, plant safety is an ongoing endeavour where it is impossible to be an expert in every field. The use of damaged or misapplied hose couplings and related items occurs. To the untrained eye these hazards may continue to exist until an accident happens threatening not only plant machinery but also the well being of personnel.

Dixon can assist in your efforts to make the facilities you service as safe, efficient and productive as possible.



OUR PROGRAM INCLUDES:

- A visual inspection of hose assemblies and related accessories
- A professionally written report detailing our observations and recommendations for corrective action.
- The safety survey report is completely confidential and will only be shown to authorised parties.

Don't Forget:

Hoses from Dixon are Certified to PED 97/23/EC Module D1 by Lloyds Register Quality Assurance.

When it's got to be right, it's got to be Dixon

For more information contact Dixon today on 01772 323529 or enquiries@dixoneurope.co.uk



Hose Assembly Safety Program

Dixon is pleased to offer a hose and coupling safety survey of your plant, at no cost to you, to assist in your efforts to make your facility as safe, efficient and productive as possible.

Today, plant safety is an enormous, ongoing endeavour in which it is impossible to be an expert in every field.

The use of damaged or misapplied hose couplings and related items occurs. To the untrained eye, these hazards may continue to exist until an accident happens, threatening not only plant machinery but also the well-being of plant personnel.

Our programme includes a visual inspection of hose assemblies and related accessories in your plant by trained technicians. A professionally written report containing our observations and recommendations for corrective action is subsequently provided to augment your own ongoing safety programme. If desired, photographs of the areas of concern can be supplied with the report. As a follow-up, the programme offers an educational hands-on seminar directly relating to the safety concerns in your facility.

Plant safety is coming under increasing scrutiny by various regulatory agencies. Let Dixon's trained personnel assist you in establishing and maintaining safety compliance in your plant.

The safety survey report is completely confidential and will only be shown to authorised plant personnel. Again, there is no cost to you for this service. For more information, please contact our technical support team.

Safety Products In This Catalogue

Safety is everyone's concern!

Dixon provides many safety products designed to protect personnel and property. Recommendations and safety warnings are also included for your review.

- Hose and coupling safety
- S.T.A.M.P.E.D.
- EZ Boss-Lock cam and groove
- Cam and groove safety clips
- Air King - not to be used for steam
- The importance of whip hose
- King cable safety cables
- Safety shut-off valves, OSHA REG. 1926.302
- 30 psi safety blow guns
- Safety vented ball valves
- Safety tags and safety tape
- Pressure recommendations

Hose & Coupling Pressure Recommendations

Mark hose assembly with pressure from this chart or hose working pressure, whichever is lower all pressure recommendations are in pounds per square inch (psi)

1. This chart is intended as a guide only. It only applies to metal couplings as shown, for ambient temperature (21°C or 70°F) applications with true I.D. hose. It assumes new Dixon supplied couplings, new Dixon supplied clamps, new quality hose and proper installation by a qualified assembler using Dixon procedures and equipment. Temperature can affect the coupling retention. For questions relating to temperatures other than ambient (21°C or 70°F) contact the hose manufacturer or Dixon.
2. This chart does not apply to non-Dixon products, with used hose, in non-approved or unsupported applications or in non-standard assemblies.
3. Do not use this chart if it conflicts with the hose manufacturer's recommendations.
4. All hose assemblies should be pressure tested to hose manufacturers or Rubber Manufacturers Association (R.M.A.) specifications prior to being put into service.
5. Our test experience indicates that coupling retention can vary with changes in hose design. For pressure ratings other than those listed and shown, or if questions arise, please call our technical support team for assistance.
6. All hose assembly components must be compatible with the materials and environments with which they are to come in contact.
7. Dixon recommends that all hose assemblies be marked with the assembly working pressure and media of the intended application. Under no circumstances should the assembly working pressure exceed the working pressure of the lowest rated component (coupling, clamp, ferrule or hose).
8. For further safety information, refer to 'The Proper Selection, Care, Use & Maintenance of Hose Couplings & Accessory Items' pamphlet.
Contact Dixon to request a copy of this literature.
9. To convert the following pressure recommendations that are stated in psi Divide the psi figure by 14.5 to convert to (bar).

** Procedures can be found at www.dixoneurope.co.uk*

Trademarks

Delrin®, Kevlar®, PTFE and Zytel® are registered trademarks of E.I. duPont Nemours and Company. Kalrez® and Viton® are registered trademarks of DuPont Dow Elastomers.

All other trademarks appearing in Dixon's Illustrated Price List are the property of their respective owners.

Pressure Recommendations

Mark hose assembly with pressure from this chart or hose working pressure, whichever is lower all pressure recommendations are in pounds per square inch (psi).

- This chart is intended as a guide only. It only applies to metal couplings as shown, for ambient temperature (20°C) applications with true I.D. hose. It assumes new Dixon supplied couplings, new Dixon supplied clamps, new quality hose and proper installation by a qualified assembler using Dixon procedures and equipment. Temperature can affect the coupling retention. For questions relating to temperatures other than ambient (20°C) contact Dixon.
- This chart does not apply to non-Dixon products, with used hose, in non-approved or unsupported applications or in non-standard assemblies.

HOSE (RUBBER LINED)	COUPLINGS	DPL SECT	CLAMPS AND FERRULES	ASSEMBLY PROCEDURE	1/4"	3/8"	1/2"	5/8"	3/4"
Air textile reinforced rubber lined	Air king Universal		Preformed Band Clamp	2102			150	150	150
	Machined - Short Shank		Crimp	2304	200	150	150	100	100
	Machined - Short Shank		Preformed Band Clamp	2100-2101			150	100	100
	Reusable - Brass		N/A	2305	250	250	250		
	king Machined - Medium Shank		Preformed Band Clamp	2100-2101			250	200	200
	king Machined - Long Shank		Preformed Band Clamp	2100-2101		150	300	300	300
Air textile or wire reinforced rubber lined	Air king Universal		Air king or Boss Interlocking Clamp	2000	600	600	150		150
	Air king Universal		Swage/Crimp	See DPL	600	600	150		150
	Boss Couplings		Boss Interlocking Clamp	200-2004			600		600
	Holedall Swage/Crimp		Swage/Crimp	See Ram Manual			600		600
Asphalt and Hot Tar	Boss Couplings		Boss Interlocking Clamp	2001-2002					
Chemical plastic lined for liquid service	king Machined - Medium Shank		Preformed Band Clamp	2100-2101			125		125
	king Machined - Medium Shank		Band & Buckle	2104					
	king Machined - Long Shank		Preformed Band Clamp	2100-2101			150		150
	king Machined - Long Shank		Band & Buckle	2104					
	Boss-Lock Cam & Groove		Preformed Band Clamp	2100-2101			150		150
	Boss-Lock Cam & Groove		Band & Buckle	2104					
	Boss-Lock Cam & Groove		Swage/Crimp	2000-2004					250
	Holedall Swage/Crimp		Swage/Crimp	See Ram Manual			600		600
Chemical rubber lined for liquid service	king Machined - Medium Shank		TPreformed Band Clamp	2100-2101			125		125
	king Machined - Medium Shank		Band & Buckle	2104					
	king Machined - Long Shank		Preformed Band Clamp	2100-2101			150		150
	king Machined - Long Shank		Band & Buckle	2104					
	Boss-Lock Cam & Groove		Preformed Band Clamp	2100-2101			150		150
	Boss-Lock Cam & Groove		Band & Buckle	See Ram Manual					
	Boss-Lock Cam & Groove		Swage/Crimp	2000-2004					250
	Boss Couplings		Boss Interlocking Clamp	2000-2004			600		600
	Holedall Internal Expansion		Internal Expansion	See Ram Manual					
	Holedall Swage/Crimp		Swage/Crimp	See Ram Manual			600		600
Food Grade conforming to 3A	Flow Chief Sanitary		Internal Expansion	See Ram Manual					
Food Grade rubber lined	king Machined - Medium Shank		Preformed Band Clamp	2100-2101			125		125
	king Machined - Medium Shank		Band & Buckle	2104					
	Boss-Lock Cam & Groove		Preformed Band Clamp	2100-2101			150		250
	Boss-Lock Cam & Groove		Band & Buckle	2104					
	Boss-Lock Cam & Groove		Swage/Crimp	See Ram Manual					250
	Holedall Internal Expansion		Internal Expansion	See Ram Manual					
	Holedall Swage/Crimp		Swage/Crimp	See Ram Manual			600		600
Swage	Flat Seal		Flat Seal Clamps	2202					

For assembly procedure see www.dixonvalve.com

Technical & Safety Information

- Do not use this chart if it conflicts with the hose manufacturer's recommendations.
- All hose assemblies should be pressure tested to hose manufacturers or Rubber Manufacturers Association (R.M.A.) specifications prior to being put into service.
- Our test experience indicates that coupling retention can vary with changes in hose design. For pressure ratings other than those listed and shown, or if questions arise, please call Dixon Group Europe Limited on +44 (0)1772 323529 for assistance.
- All hose assembly components must be compatible with the materials and environments with which they are to come in contact.
- Dixon recommends that all hose assemblies be marked with the assembly working pressure and media of the intended application. Under no circumstances should the assembly working pressure exceed the working pressure of the lowest rated component (coupling, clamp, ferrule or hose).

*Procedures can be found at www.dixoneurope.co.uk or by calling 01772 323529.

HOSE (RUBBER COVERED)	1"	1 1/4"	1 1/2"	2"	2 1/2"	3"	4"	5"	6"	SPECIAL NOTES
Air textile reinforced rubber lined	150 100 100 150 300									(2) bands on 5/8" or larger Must use mating Dixon Air king fittings with safety clip installed. (2) bands on 1/2" to 1".
Air textile or wire reinforced rubber lined	150 150 600 600	600 600	600 600	600 600	450 600	450 600	250 500	450	250 400	Must use mating Dixon Air King fittings with safety clip installed. Coupling and Ferrule are sold assembled. Must use mating Dixon Air King fittings with safety clip installed.
Asphalt and Hot Tar	200	200	200	200	200	200	200			Consult factory.
Chemical plastic lined for liquid service	125 150 250 250 250 600	125 125 150 150	125 125 150 150	75 75 125 125	75 75 100 100	50 50 75 75	50 50 75 75			(3) bands on 3" & 4"; (2) bands on 1 1/2" to 2 1/2"; (1) band on the rest. (3) bands on 3" & 4"; (2) bands on 1 1/2" to 2 1/2"; (1) band on the rest. (5) bands on 3" & 4"; (4) bands on 2" & 2 1/2"; (3) bands on 1 1/4" & 1 1/2" (2) bands on the rest. (5) bands on 3" & 4"; (4) bands on 2" & 2 1/2"; (3) bands on the rest. Require property matched Stem and Ferrule.
Chemical rubber lined for liquid service	125 125 150 150 250 250 600 800 600	125 125 150 150 250 250 600 800 600	125 125 150 150 250 250 600 800 600	75 75 125 125	75 75 100 100	50 50 75 75	50 50 75 75			(3) bands on 3" & 4"; (2) bands on 1 1/2" to 2 1/2"; (1) band on the rest. (3) bands on 3" & 4"; (2) bands on 1 1/2" to 2 1/2"; (1) band on the rest. (5) bands on 3" & 4"; (4) bands on 2" & 2 1/2"; (3) bands on 1 1/4" & 1 1/2" (2) bands on the rest. (5) bands on 3" & 4"; (4) bands on 2" & 2 1/2"; (3) bands on the rest. Require properly matched Stem and Ferrule. Consult factory for ratings on IXF48-3 to IXF4848-5 & IXF64-2 to IXF64-5 ferrules. Internal Expansion is NOT recommended for XLPE, UHMWPE & Gum rubber lined hose.
Food Grade conforming to 3A			250	250		250				Use Stainless Steel Food Grade Ferrule ONLY.
Grade rubber lined	125 125 250 250 250 600	125 125 250 250 250 600	125 125 250 250 250 600	75 75 250 250	75 75 150 150	50 50 125 125	50 50 100 100	25 25 75 75	25 25 75 75	(4) bands on 6"; (3) bands on 3" to 5"; (2) bands on 1 1/2" to 2 1/2"; (1) band on the rest. (4) bands on 6"; (3) bands on 3" to 5"; (2) bands on 1 1/2" to 2 1/2"; (1) band on the rest. (3) bands on 6"; (2) bands on rest. (3) bands on 6"; (2) bands on rest. Require properly matched Stem and Ferrule.
Layflat			300	300	300	300	225		150	To be used as a set ONLY. 6" Cam & Groove couplings are rated to 75psi.

Pressure Recommendations

HOSE (RUBBERCOVERED)	COUPLINGS	DPL SECT	CLAMPS AND FERRULES	*ASSEMBLY PROCEDURE*	1/4"	3/8"	1/2"	5/8"	3/4"
Material Handling rubber lined	Cast Short Shank		Preformed Band Clamp	2100-2101					
	Cast Short Shank		Band & Buckle	2104					
	King Machined - Medium Shank		Preformed Band Clamp	2100-2101					
	King Machined - Medium Shank		Band & Buckle	2104					
	King Machined - Long Shank		Preformed Band Clamp	2100-2101					
	King Machined - Long Shank		Band & Buckle	2104					
	Boss-Lock Cam & Groove		Preformed Band Clamp	2100-2101					
	Boss-Lock Cam & Groove		Band & Buckle	2104					
	Boss-Lock Cam & Groove		Swage/Crimp	see Ram Manual					
	Holedall Swage/Crimp		Swage/Crimp	see Ram Manual					
Material Handling rubber helical wire rubber lined	Holedall Internal Expansion		Internal Expansion	see Ram Manual					
	Cast Short Shank		Double Bolt Clamp	2201					
	King Machined - Medium Shank		Double Bolt Clamp	2201					
Material Handling cement rubber lined	King Machined - Long Shank		Double Bolt Clamp	2201					
	Boss Couplings		Boss Interlocking Clamp	2000-2004					
	Holedall Swage/Crimp		Swage/Crimp	see Ram Manual					
Petroleum Transfer	Holedall Internal Expansion		Internal Expansion	see Ram Manual					
	King Machined - Medium Shank		Preformed Band Clamp	2100-2101			125		125
	King Machined - Medium Shank		Band & Buckle	2104					
	King Machined - Long Shank		Preformed Band Clamp	2100-2101			150		150
	King Machined - Long Shank		Band & Buckle	2104					
	Boss-Lock Cam & Groove		Preformed Band Clamp	2100-2101			150		250
	Boss-Lock Cam & Groove		Band & Buckle	2104					
	Boss-Lock Cam & Groove		Swage/Crimp	see Ram Manual					250
Air Craft Refuelling conforming to API 1529	Holedall Internal Expansion		Internal Expansion	see Ram Manual			600		600
	Expansion Petroleum		Internal Expansion - Petroleum	see Ram Manual					
	Push On		N/A	2001-2002	175	175	175	175	175
Steam	Boss Couplings		Boss Interlocking Clamp	2000-2004			250		250
Water	Air King Universal		Preformed Band Clamp	2100-2101			150	150	150
	Air King Universal		Air King or Boss Interlocking Clamp	2000-2001			150	150	
	Machined - Short Shank		Preformed Band Clamp	2100-2101			150	100	100
	Machined - Short Shank		Crimp	2304	200	150	150	100	100
	Cast Short Shank		Preformed Band Clamp	2100-2101			150	100	100
	Cast Short Shank		Band & Buckle	2104					
	King Machined - Medium Shank		Preformed Band Clamp	2100-2101			250	200	200
	King Machined - Long Shank		Preformed Band Clamp	2100-2101			300	300	300
	Boss-Lock Cam & Groove		Preformed Band Clamp	2100-2101			150		250
	Boss-Lock Cam & Groove		Band & Buckle	2104					
	Boss-Lock Cam & Groove		Swage/Crimp	see Ram Manual					250
	Boss Couplings		Boss Interlocking Clamp	2000-2002	600	600	600		600
	Holedall Swage/Crimp		Swage/Crimp	see Ram Manual	600	600	600		600
Water no helical wire	Cast Short Shank		Double Bolt Clamp	2201					
	King Machined - Medium Shank		Double Bolt Clamp	2201					
	King Machined - Long Shank		Double Bolt Clamp	2201					

For assembly procedure see www.dixonvalve.com

Pressure Recommendations

HOSE (RUBBER COVERED)	1"	1 1/4"	1 1/2"	2"	2 1/2"	3"	4"	5"	6"	SPECIAL NOTES
Material Handling rubber lined			75	75	50	50	50	25	25	(4) bands on 6"; (3) bands on 3" to 5"; (2) bands on 1 1/2" to 2 1/2".
			75	75	50	50	50	25	25	(4) bands on 6"; (3) bands on 3" to 5"; (2) bands on 1 1/2" to 2 1/2".
			125	75	75	50	50	25	25	(4) bands on 6"; (3) bands on 3" to 5"; (2) bands on 1 1/2" to 2 1/2".
			125	75	75	50	50	25	25	(4) bands on 6"; (3) bands on 3" to 5"; (2) bands on 1 1/2" to 2 1/2".
			150	125	100	75	75			(5) bands on 3" & 4"; (4) bands on 2" & 2 1/2"; (3) bands on the rest.
			150	125	100	75	75			(5) bands on 3" & 4"; (4) bands on 2" & 2 1/2"; (3) bands on the rest.
			250	250	150	100	100	75	75	(3) bands on 6"; (2) bands on rest
			250	250	150	100	100	75	75	(3) bands on 6"; (2) bands on rest
			250	250		125	100			Require properly matched Stem and Ferrule
			600	600	600	500	500	450	400	
Material Handling no helical wire			75	75	50	50	50	25	25	(3) double bolt clamps on 5" & 6"; (2) double bolt clamps on 3" to 4"; (1) double bolt clamp on the rest
			125	75	50	50	50	25	25	(3) double bolt clamps on 5" & 6"; (2) double bolt clamps on 3" to 4"; (1) double bolt clamp on the rest.
			150	125	100	75	75			(3) double bolt clamps on all sizes.
Material Handling cement rubber lined	600	600	600	600	450	450	250		250	Cement will erode I.D.
	600	600	600	600	600	500	500	450	400	Cement will erode I.D.
	800	800	800	800	600	500	500		400	Cement will erode I.D. Consult factory for ratings on IXF48-3 to IXF48-5 & IXF64-2 to IXF64-5 ferrules.
Petroleum Transfer	125	125	125	75	50	50	50	25	25	(4) bands on 6"; (3) bands on 3" to 5"; (2) bands on 1 1/2" to 2 1/2"; (1) band on the rest.
		125	125	75	75	50	50	25	25	(4) bands on 6"; (3) bands on 3" to 5"; (2) bands on 1 1/2" to 2 1/2"
										(1) band on the rest.
	150	150	150	125	100	75	75			(5) bands on 3" & 4"; (4) bands on 2" & 2 1/2"; (3) bands on 1 1/4" & 1 1/2"; (2) bands on the rest.
		150	150	125	100	75	75			(5) bands on 3" & 4"; (4) bands on 2" & 2 1/2"; (3) bands on the rest.
	250	250	250	250	150	125	100	75	75	(3) bands on 6"; (2) bands on rest
		250	250	250	150	125	100	75	75	(3) bands on 6"; (2) bands on rest
250		250	250		125	100			Requires properly matched stem & ferrules	
800	800	800	800	600	600	500		400	Consult factory for ratings on IXF48-3 to IXF48-5 to IXF54-2 to IXF64-5 ferrules	
600	600	600	600	600	600	500	450	400		
Air Craft Refuelling conforming to API 1529	300	300	300	300	300	300				
Push On										Push-On fittings should ONLY be used on Push-On hose
Steam	250	250	250	250	250	250			250	
Water	150									(2) bands on 5/8" or larger; Must use mating Dixon Air King fittings with safety clip installed Band & Buckle not recommended.
	150									Must use mating Dixon Air King fittings with safety clip installed Band & Buckle not recommended.
	100									Band & Buckle not recommended.
	100	75	75	75	50	50	50	25	25	(4) bands on 6"; (3) bands on 3" to 5"; (2) bands on 1 1/2" to 2 1/2"; (1) band on the rest.
	100	75	75	75	50	50	50	25	25	(4) bands on 6"; (3) bands on 3" to 5"; (2) bands on 1 1/2" to 2 1/2"; (1) band on the rest.
	150	150	125	75	75	50	50	25	25	(4) bands on 6"; (3) bands on 3" to 5"; (2) bands on 1 1/2" to 2 1/2"
										(1) band on the rest.
	300	300	150	125	100	75	75			(5) bands on 3" & 4"; (4) bands on 2" & 2 1/2"; (3) bands on 1 1/4" & 1 1/2"; (2) bands on the rest.
	250	250	250	250	150	125	100	75	75	(3) bands on 6"; (2) bands on rest.
	250	250	250	250	150	125	100	75	75	(3) bands on 6"; (2) bands on rest
250		250	250		125	100			Require properly matched Stem and Ferrule	
600	600	600	600	450	450	250		250		
600	600	600	600	600	600	500	450	400		
Water no helical wire			75	75	50	50	50	25	25	(3) double bolt clamps on 5" & 6"; (2) double bolt clamps on 3" to 4"; (1) double bolt clamp on the rest.
			125	75	75	50	50	25	25	(3) double bolt clamps on 5" & 6"; (2) double bolt clamps on 3" to 4"; (1) band on the rest.
			150	125	100	75	75			(3) double bolt clamps on all sizes.

For assembly procedure see www.dixonvalve.com

Corrosion Resistance Guide

CAUTION

The following data has been compiled from generally available sources and should not be relied upon without consulting and following the specific recommendations of the manufacturer regarding particular coupling materials.

METAL	NON-METAL	GASKET/SEAL MATERIAL
1 - Excellent 2 - Good 3 - Fair X - Not Recommended -- Contact Factory	A - Acceptable X - Not Recommended -- Contact Factory	T - PTFE V - Viton® E - EPDM, EPR N - Neoprene B - Buna N

Ratings

Note:

- (1) Ratings given are based at 20°C or 70°F. Chemical compatibility varies greatly with temperature. For applications at temperatures other than 20°C or 70°F, contact the Factory for recommendations.
- (2) Gasket / seal materials are not necessarily listed in order of preference.
- (3) Chemical resistance of a material does not necessarily indicate the suitability of a fitting in a given application due to variables such as improper clamp and coupling application, special hose construction, gasket material, etc.

Special caution should be taken when handling hazardous materials.

Technical & Safety Information

AGENT	Aluminium	Brass	Bronze	Hastelloy, C-276	Malleable Iron Carbon Steel	Monel	Stainless Steel,304	Stainless Steel,316	Nylon	Polypropylene	Seal Material
Acetate Solvents (Crude)	1	X	X	1	2	2	1	1	A	X	T
Acetate Solvents (Pure)	1	1	1	1	X	1	1	1	A	X	T
Acetic Acid (80%)	3	X	X	1	X	1	1	1	X	X	TEVNB
Acetic Acid (50%)	2	X	X	1	X	2	2	1	X	X	TEVNB
Acetic Acid (20%)	2	X	X	1	X	2	2	1	X	X	TEVNB
Acetic Acid (10%)	2	X	2	1	X	2	1	1	X	X	TEVNB
Acetic Anhydride	2	X	2	1	2	2	2	2	X	X	TNB
Acetone	1	2	2	1	2	1	1	1	A	X	TE
Acetylene	1	X	X	2	2	2	1	1	X	X	TEVNB
Alcohols											
Amyl Alcohol	2	2	2	2	2	1	2	2	A	A	TEVNB
Benzyl Alcohol	2	2	2	2	2	1	1	1	X	A	TVB
Butyl Alcohol	1	2	1	2	2	1	1	1	A	A	TEVN
Diacetone Alcohol	1	1	2	1	2	1	2	2	X	A	TE
Ethyl Alcohol	1	2	2	1	2	2	2	2	X	A	TEVNB
Hexyl Alcohol	-	-	-	1	-	-	-	-	A	-	-
Isobutyl Alcohol	-	-	-	-	-	-	-	-	A	-	-
Isopropyl Alcohol	2	2	2	2	2	2	2	2	A	A	TEVNB
Methyl Alcohol (Methanol)	2	2	2	1	2	2	2	2	A	A	TENB
Octyl Alcohol	-	-	-	-	-	-	-	-	A	-	-
Propyl Alcohol	2	2	2	1	2	2	1	1	X	A	TEVNB
Aluminum											
Aluminum Chloride (Aqu.)	X	X	X	1	X	X	X	X	A	A	TEVNB
Aluminum Fluoride (Sat.)	2	-	-	-	X	2	X	2	X	A	TEVNB
Aluminum Nitrate (Sat.)	3	X	-	-	X	-	2	2	A	A	TEVNB
Aluminum Potassium Sulphate (Alum)	2	2	2	2	X	2	X	2	X	A	TEVNB
Aluminum Sulphate (Sat.)	X	X	2	2	X	2	-	2	A	A	TEVNB
Ammonia											
Ammonia Anhydrous	1	X	X	2	1	1	2	1	A	X	TENB
Ammonia Gas	X	X	X	1	1	X	1	1	A	X	TENB
Ammonia Nitrate	-	-	-	-	-	-	-	-	X	-	-
Ammonium											
Ammonium Bifluoride	-	X	-	2	X	2	-	-	X	A	TEVB
Ammonium Carbonate (Sat.)	2	X	X	2	2	2	2	2	A	A	TEVNB
Ammonium Casenate	-	-	-	-	-	-	-	-	A	-	-
Ammonium Chloride (Sat.)	X	X	2	2	X	2	X	X	A	A	TEVNB
Ammonium Hydroxide (Sat.)	2	X	X	2	1	X	2	2	A	A	TEVNB
Ammonium Nitrate	2	X	X	-	X	X	-	-	A	A	TENB
Ammonium Phosphate (10-40%)	X	X	X	-	X	2	1	2	A	A	TEVNB
Ammonium Sulphate (10-40%)	X	X	3	2	X	2	X	2	A	A	TEVNB
Aniline	-	X	2	2	X	2	1	1	X	X	TV
Arsenic Acid	X	X	2	2	X	X	2	2	X	A	TEVNB
Asphalt	-	-	-	-	2	-	-	2	X	X	TV
Barium											
Barium Carbonate (Sat.)	X	2	2	2	2	2	2	2	A	A	TEVNB
Barium Chloride (Sat.)	-	2	2	1	-	2	X	-	A	A	TEVNB
Barium Hydroxide (Sat.)	X	2	X	2	2	1	2	2	A	A	TEVNB
Barium Sulphate	2	2	2	-	X	2	2	2	A	A	TEVNB
Barium Sulphide	X	X	X	-	2	X	2	2	A	A	TEVNB
Beer	1	2	2	1	2	1	1	1	A	A	TEVNB
Benzaldehyde	2	2	2	2	X	2	2	2	X	X	TE
Benzene, Benzol	1	2	2	2	2	2	2	2	A	X	TV
Benzine	-	-	-	-	-	-	-	-	A	X	-
Benzoic Acid	2	2	2	-	X	2	2	2	X	X	TVN
Black Liquor	X	X	X	X	-	2	2	2	X	A	TEVNB
Bleach (12.5% Active Chlorine)	X	-	-	1	X	-	-	X	X	A	TEVN
Borax	X	2	2	1	2	1	1	1	X	A	TEVNB
Boric Acid	1	X	2	1	X	2	-	-	X	A	TEVNB
Brine Acid	-	2	2	1	-	-	-	-	X	A	TEVNB
Bromic acid	X	X	X	-	-	X	-	-	X	A	TEVN
Bromine Liquid	2	-	-	-	-	-	X	X	X	X	TV
Butadiene, Butylene	2	2	2	2	2	1	2	2	X	X	TVNB
Butane	2	2	2	2	1	1	2	2	X	X	TV
Butyl Acetate	1	2	2	2	2	2	2	2	A	X	T
Butyric Acid	2	2	X	1	X	2	2	2	A	A	TV

AGENT	Aluminium	Brass	Bronze	Hastelloy, C-276	Malleable Iron Carbon Steel	Monel	Stainless Steel,304	Stainless Steel,316	Nylon	Polypropylene	Seal Material
Calcium											
Calcium Bisulphate	X	-	X	-	X	X	X	2	X	A	T
Calcium Bisulphide	-	-	-	-	-	2	-	2	A	A	TVB
Calcium Bisulphite	X	X	2	2	X	X	-	2	X	A	TVNB
Calcium Bromide	X	G	G	-	X	G	E	X	X	X	T
Calcium Carbonate	X	2	2	2	2	2	1	2	A	A	TEVB
Calcium Chloride (Sat.)	-	2	-	1	2	2	-	-	A	A	TEVNB
Calcium Hydroxide (Sat.)	X	2	X	-	2	2	2	2	A	A	TEVNB
Calcium Hypochlorite (Sat.)	X	X	X	-	X	X	X	2	X	A	TEV
Carbon											
Carbon Bisulphide	1	X	2	2	2	X	2	2	A	X	TV
Carbon Dioxide (Dry)	1	1	2	1	2	1	2	2	A	A	TENB
Carbon Dioxide (Wet)	1	X	-	2	3	-	2	2	X	A	TENB
Carbon Disulphide	1	X	2	2	2	X	2	2	A	X	TV
Carbon Monoxide	1	1	1	1	2	1	1	1	A	A	TEVNB
Carbon Tetrachloride	X	-	1	1	2	1	1	-	A	X	TV
Carbonic Acid	1	2	2	1	2	3	2	2	X	A	TEVNB
Castor Oil	2	2	2	1	2	1	2	2	X	A	TEVNB
Caustic Potash	X	-	-	1	X	-	-	2	A	A	TEVNB
Caustic Soda (see Sodium Hydroxide)											
Cellosolves	2	2	2	2	2	2	2	2	X	A	TE
Chlorine (Liquid)	-	-	-	1	2	2	-	3	X	X	TV
Chloroform	-	-	-	2	X	1	-	-	X	X	TV
Chlorosulphonic Acid	-	X	X	1	2	2	X	X	X	X	T
Clorox (Bleach, 5.5% CL)	X	-	-	-	X	-	-	2	X	-	TEVB
Chromic Acid (50%)	2	X	X	2	X	X	3	-	X	X	TVNB
Citric Acid	3	X	X	1	X	2	-	-	X	A	TEVNB
Coke Oven Gas	2	3	3	-	2	2	2	2	X	X	TEVN
Copper											
Copper Chloride	X	X	X	2	X	X	X	X	A	A	TEVNB
Copper Cyanide	X	X	X	1	-	X	2	2	X	-	TEVNB
Copper Sulphate	X	X	X	1	X	X	-	2	A	A	TEVNB
Crysylic Acid (Conc.)	2	2	X	-	2	3	2	2	X	X	TEV
Cyclohexane	2	2	2	2	2	1	2	2	A	X	TVB
Detergents	2	2	2	1	2	-	1	2	A	A	TEVNB
Dextrose	2	-	-	2	-	2	-	-	A	A	TEVNB
Diesel Fuels	1	1	1	2	2	-	1	1	A	X	TVB
Diethylamine	2	-	X	-	X	1	2	2	X	A	TN
Disodium Phosphate	-	-	-	-	1	-	-	1	A	A	TEV
Ethers	2	2	2	2	2	2	1	1	A	X	TB
Ethyl											
Ethyl Acetate	-	-	2	2	2	2	2	2	A	X	T
Ethyl Chloride	-	-	2	2	2	2	-	1	A	X	TEVB
Ethylene											
Ethylene Chloride	-	-	-	-	2	2	-	-	A	X	TV
Ethylene Dichloride	-	2	X	2	2	1	2	2	A	X	TV
Ethylene Glycol	1	2	2	1	2	2	2	2	A	X	TEVNB
Ethylene Oxide	1	X	X	1	2	2	2	2	X	X	T
Fatty Acids	1	3	3	1	X	2	-	1	A	A	TVNB
Ferric											
Ferric Chloride	X	X	2	2	X	X	X	X	X	A	TEVNB
Ferric Hydroxide	-	-	-	1	-	2	1	1	A	-	TEVNB
Ferric Nitrate (10-50%)	X	X	X	-	X	X	2	2	X	A	TEVNB
Ferric Sulphate	X	X	X	-	X	2	-	-	X	A	TEVNB
Ferrous											
Ferrous Chloride (Sat.)	X	X	2	2	-	X	X	X	X	A	TEVNB
Ferrous Sulphate	2	2	2	2	X	2	2	-	X	A	TEVNB
Fluoroboric Acid	X	-	-	1	1	2	-	-	X	A	TEVNB
Formaldehyde (50%)	-	2	2	2	X	2	1	1	X	A	TEN
Formic Acid (Anhyd.)	1	X	2	1	X	2	-	-	X	A	TEVN
Freon											
Freon 11	2	2	2	-	X	1	2	2	X	X	TVNB
Freon 12	2	2	2	1	X	2	2	2	X	X	TVNB
Freon 22	2	2	2	2	X	2	2	2	X	X	TN
Fruit Juices	2	2	3	1	X	1	2	2	A	A	TVNB
Fuel Oil	2	2	2	2	2	2	2	2	A	X	TVNB
Furfural	2	2	2	2	2	2	2	2	A	X	TEN

Technical & Safety Information

AGENT	Aluminium	Brass	Bronze	Hastelloy, C-276	Malleable Iron Carbon Steel	Monel	Stainless Steel,304	Stainless Steel,316	Nylon	Polypropylene	Seal Material
Gasoline											
Refined Gasoline	2	2	2	2	2	2	2	2	A	X	TVNB
Sour Gasoline	X	2	2	2	2	X	2	2	A	X	TVNB
Gelatin	2	2	2	-	X	2	2	2	A	A	TEVNB
Glucose	2	2	2	-	2	2	2	2	A	A	TEVNB
Glue	2	2	2	1	2	2	-	2	-	A	TEVNB
Glycerine	1	1	2	1	2	1	1	1	A	A	TEVNB
Glycols	2	2	2	-	2	2	2	2	A	A	TEVNB
Green Liquor	-	-	-	-	2	-	-	-	-	A	TEVNB
Heptane	2	2	2	1	2	2	2	2	A	X	TVNB
Hexane	2	2	2	1	2	2	1	1	A	X	TVNB
Hydrobromic Acid (50%)	X	X	X	2	X	X	X	X	X	A	TEV
Hydrobromic Acid (20%)	X	X	X	1	X	X	X	X	X	A	TEV
Hydrochloric Acid (20%)	X	X	X	1	X	3	X	X	X	A	TEVNB
Hydrochloric Acid (38%)	X	X	X	1	X	X	X	X	X	A	TEVN
Hydrocyanic Acid	2	X	X	2	2	2	2	2	X	A	TEVN
Hydrofluorosilicic Acid (10-50%)	X	2	X	2	X	2	X	2	X	-	TEVNB
Hydrogen											
Hydrogen Peroxide (50%)	-	X	X	2	X	2	-	-	X	A	TEV
Hydrogen Sulphide (Aqu.)	-	-	-	2	-	2	X	2	X	A	TE
Hydrogen Chloride (Dry Gas)	X	2	-	1	2	1	-	-	X	A	TEVN
Hydrogen Gas	1	1	1	1	-	1	1	1	X	A	
Hypochlorous Acid	X	X	X	2	X	X	X	X	X	X	TEV
Iodine	1	X	X	-	X	1	X	X	X	A	TEV
Isopropyl Ether	-	2	2	-	-	2	1	2	A	X	T
Jet Fuel (JP4, JP5)	2	1	2	1	2	2	2	2	X	X	TV
Kerosene	2	2	2	2	2	2	2	2	X	X	TVNB
Ketones	2	2	2	1	2	2	2	2	A	X	T
Lactic Acid (25%)	3	2	2	1	X	X	-	-	A	A	TEVN
Lactic Acid (80%)	2	2	X	2	X	-	-	-	A	A	TEVN
Lard Oil	2	-	2	1	3	2	2	2	A	A	TVB
Lead											
Lead Acetate	X	X	X	2	X	2	2	2	X	A	TENB
Lead Chloride	X	-	-	2	-	-	2	2	X	-	TVNB
Lead Sulphate	X	-	-	2	X	2	2	2	X	-	TEVNB
Lime Sulphur	X	X	X	-	X	2	2	2	X	A	TEVN
Linoleic Acid	2	X	3	2	X	2	2	2	X	A	TVB
Linseed Oil	2	2	2	2	2	2	2	2	A	A	TVNB
Lubricants (Oil)	2	1	-	-	2	2	2	2	A	X	TVNB
Magnesium											
Magnesium Carbonate	2	-	-	-	-	2	2	2	X	A	TEVNB
Magnesium Chloride	X	X	2	1	-	-	-	-	X	A	TEVNB
Magnesium Hydroxide	2	2	2	1	2	2	1	1	X	A	TEVNB
Magnesium Nitrate	2	2	2	1	2	2	2	2	X	A	TEVNB
Magnesium Oxide	-	-	-	-	-	-	-	-	X	-	-
Magnesium Sulphate	2	-	2	-	-	1	2	2	X	A	TEVNB
Maleic Acid	-	2	3	2	X	-	-	2	X	A	TEV
Mercuric											
Mercuric Chloride	X	X	X	-	X	X	X	-	X	A	TEVB
Mercuric Cyanide	X	X	X	2	X	2	2	2	X	A	TEVB
Mercury	X	X	X	1	2	-	1	1	A	A	TEVNB
Methane	1	1	2	1	2	1	1	1	A	X	TEVNB
Methanol	2	2	2	1	2	2	2	2	A	A	TENB
Methyl											
Methyl Bromide	X	-	-	-	2	-	2	2	X	X	TV
Methyl Ethyl Ketone	2	2	2	2	2	2	2	2	A	X	TE
Methyl Isobutyl Ketone	2	2	2	2	2	2	2	2	A	X	T
Methyl Methacrylate	2	-	-	-	X	-	2	2	X	A	T
Methylene Chloride	-	2	2	X	2	-	-	-	A	X	T
Milk	1	X	X	1	2	X	1	1	A	A	TEVNB
Mineral Oil	2	1	-	-	2	1	1	2	A	A	TVNB
Muriatic Acid	X	-	-	1	-	X	X	X	X	A	TV
Napthalene	2	2	2	2	2	2	1	1	A	A	TV
Naptha	2	2	2	2	2	2	2	2	A	X	TVB

AGENT	Aluminium	Brass	Bronze	Hastelloy, C-276	Malleable Iron Carbon Steel	Monel	Stainless Steel,304	Stainless Steel,316	Nylon	Polypropylene	Seal Material
Nickel											
Nickel Chloride	X	X	X	-	X	2	-	-	X	A	TEVNB
Nickel Sulphate	X	X	-	2	-	-	2	2	X	A	TEVNB
Nitric											
Nitric Acid (100%)	1	X	X	2	X	X	2	-	X	X	TV
Nitric Acid (50%)	X	X	X	1	X	X	2	-	X	X	TV
Nitric Acid (30%)	X	X	X	1	X	X	1	-	X	X	TV
Nitrobenzene	1	2	2	-	2	2	2	2	A	A	T
Oils											
Castor Oil	2	2	2	1	2	1	2	2	A	A	TEVNB
Coconut Oil	2	-	2	-	3	2	2	2	A	A	TVB
Corn Oil	2	2	2	-	2	2	-	2	A	A	TVNB
Cotton Seed Oil	2	2	2	-	2	1	2	2	A	A	TVNB
Fuel Oil	2	2	2	2	2	2	2	2	A	X	TVNB
Linseed Oil	2	2	2	2	2	2	2	2	A	A	TVNB
Mineral Oil	2	1	-	-	2	1	1	2	A	A	TVNB
Silicon Oil	2	1	2	-	2	-	2	2	A	A	TEVB
Vegetable Oil	2	2	2	1	2	1	1	1	A	X	TVNB
Oleic Acid	2	3	2	2	2	1	-	1	A	X	TB
Oleum	2	X	X	-	2	X	2	2	X	X	TV
Oxalic Acid (Sat.)	2	-	2	2	X	2	X	X	X	A	TEV
Oxygen	2	2	2	-	2	2	2	2	X	X	TEVNB
Palmitic Acid (Sat.)	2	3	2	-	3	2	2	2	X	A	TVB
Paraffin	2	2	2	2	2	2	2	2	A	A	TVNB
Perchloroethylene	2	2	2	2	2	1	-	-	X	X	TV
Petrolatum	2	-	2	-	3	2	2	2	A	-	TVNB
Phenol (Carbolic Acid)	1	1	X	1	2	1	-	1	X	X	TV
Phosphoric Acid											
Phosphoric Acid (25-50%)	X	X	2	1	X	X	-	-	X	A	TEVN
Phosphoric Acid (50-85%)	X	X	X	1	X	3	-	-	X	A	TEV
Photographic Solutions	-	-	-	-	X	1	1	1	X	X	TVNB
Phthalic Anhydride	-	2	2	1	2	1	1	1	X	X	TEV
Picric Acid	1	X	X	2	X	X	2	2	X	-	TEVNB
Plating Solutions											
Brass Plating Solution	-	-	-	1	-	-	-	2	X	A	TEVNB
Cadmium Plating Solution	-	-	-	1	-	-	-	2	X	A	TEVNB
Chrome 40% Plating Solution	X	2	2	1	X	X	2	2	X	A	TEVN
Copper (Cyanide) Plating Solution	-	-	-	1	-	-	-	-	X	A	TEVNB
Gold Plating Solution	-	-	-	1	-	-	-	1	X	A	TEVNB
Iron Plating Solution	-	-	-	-	-	-	-	-	X	A	TEVB
Lead Plating Solution	-	-	-	-	-	-	1	1	X	A	TEVNB
Nickel Plating Solution	-	-	-	1	-	-	1	1	X	A	TEVNB
Silver Plating Solution	-	-	-	1	-	-	1	1	X	A	TEVNB
Tin Plating Solution	-	-	-	1	-	-	-	3	X	A	TEVNB
Zinc Plating Solution	-	-	-	1	-	-	-	-	X	A	TEVNB
Potassium											
Potassium Acetate	X	X	X	-	2	-	-	-	A	A	TEVB
Potassium Bicarbonate (30%)	X	2	-	2	2	2	1	1	A	A	TEVNB
Potassium Carbonate (50%)	X	2	X	2	2	2	1	1	A	A	TEVNB
Potassium Chlorate (30%)	2	X	X	-	2	2	2	1	X	A	TEVNB
Potassium Chloride (30%)	X	X	2	-	2	1	-	-	A	A	TEVNB
Potassium Chromate (30%)	2	2	2	2	-	2	2	2	X	A	TEVB
Potassium Cyanide Solution (30%)	X	X	X	2	2	2	2	2	X	A	TEVNB
Potassium Dichromate (30%)	1	2	2	2	2	2	1	1	X	A	TEVB
Potassium Hydroxide (90%)	X	X	X	2	-	2	X	-	X	A	TENB
Potassium Nitrate (80%)	1	2	2	2	2	2	2	2	X	A	TEVNB
Potassium Permanganate (20%)	2	2	2	1	2	2	2	2	X	A	TEVN
Potassium Sulphate (10%)	1	2	2	1	2	1	1	1	A	A	TEVNB
Propane	1	1	1	2	2	1	2	2	X	X	TVB
Propylene Glycol	2	2	2	2	2	2	2	2	A	A	TVNB
Propylene Oxide (90%)	-	-	-	-	-	-	1	1	X	X	TE
Pyridine	2	2	2	-	2	2	2	2	A	X	T
Pyrogalllic Acid	2	2	2	2	2	2	2	2	X	X	TVNB
Silver Nitrate	X	X	X	-	X	X	2	1	X	A	TEVNB
Soap Solutions	2	2	2	1	2	2	2	2	A	A	TEVNB

Technical & Safety Information

AGENT	Aluminium	Brass	Bronze	Hastelloy, C-276	Malleable Iron Carbon Steel	Monel	Stainless Steel,304	Stainless Steel,316	Nylon	Polypropylene	Seal Material
Sodium											
Sodium Acetate	1	2	2	-	X	2	2	2	A	A	TEN
Sodium Bicarbonate (20%)	2	2	2	1	3	1	1	1	A	A	TEVNB
Sodium Bisulphate	X	-	2	2	2	-	-	-	A	A	TEVNB
Sodium Bisulphite	X	2	X	2	X	-	-	-	A	A	TEVNB
Sodium Borate	2	2	2	2	3	2	2	2	A	A	TEVNB
Sodium Perborate (10%)	2	X	2	2	2	2	2	2	X	A	TEVNB
Sodium Carbonate	X	2	-	2	2	1	-	2	A	A	TEVNB
Sodium Chlorate (50%)	2	2	2	1	X	1	2	2	X	A	TEVNB
Sodium Cyanide	X	X	X	2	2	X	-	-	A	A	TEVNB
Sodium Dichromate	2	X	X	1	2	-	2	2	X	A	TE
Sodium Hydroxide (70%)	X	X	X	1	3	1	2	2	X	A	TENB
Sodium Hydroxide (50%)	X	X	3	1	3	1	1	-	X	A	TENB
Sodium Hydroxide (30%)	X	2	3	2	2	1	1	1	X	A	TENB
Sodium Chloride (30%)	X	2	2	2	2	1	-	-	X	A	TEVNB
Sodium Hypochlorite	X	X	X	-	X	X	-	-	X	A	TEV
Sodium Metaphosphate	X	X	2	-	X	2	2	2	X	X	TEVNB
Sodium Nitrate (40%)	1	2	-	-	2	2	1	1	A	A	TENB
Sodium Perborate (10%)	2	X	2	2	2	2	2	2	X	A	TEVNB
Sodium Peroxide (10%)	2	X	X	2	2	2	2	2	X	A	TEVNB
Sodium Silicate	1	2	2	2	2	2	2	2	A	A	TEVNB
Sodium Sulphate	-	2	2	2	2	-	-	1	A	A	TEVNB
Sodium Sulphide (50%)	X	X	X	2	2	2	-	2	X	A	TEVNB
Sodium Thiosulphate	2	X	X	2	X	2	2	2	A	A	TEVNB
Stannic Chloride	X	X	X	-	X	X	X	X	X	A	TEVNB
Stannous Chloride	X	X	X	2	X	-	X	-	X	X	TEVNB
Steam	-	-	-	-	-	-	-	-	X	-	-
Stearic Acid	2	3	2	1	3	3	2	1	A	A	TVNB
Stoddard's Solvent	2	2	2	1	2	2	2	2	X	A	TVB
Sugar Liquors (Cane)	1	2	1	-	2	2	2	2	A	A	TEVNB
Sugar Liquors (Beet)	1	2	1	-	2	1	1	1	A	A	TEVNB
Sulphate Liquors	2	X	X	2	3	2	-	2	X	A	TVNB
Sulphite Liquors	X	X	-	1	X	X	2	2	X	X	TVNB
Sulphur Chloride	X	-	X	2	X	X	-	-	X	X	TV
Sulphur Dioxide (Dry)	2	2	2	2	1	2	-	2	X	A	TE
Sulphur Trioxide	2	2	X	2	2	2	-	2	X	X	TEV
Sulphuric Acid (TO 10%)	X	2	X	1	X	X	X	X	X	A	TEVNB
Sulphuric Acid (100%)	X	X	X	1	2	X	-	-	X	X	TV
Sulphurous Acid	2	2	X	-	X	X	X	-	X	A	TV
Tannic Acid	X	-	X	-	X	2	2	2	X	A	TEVNB
Tanning Liquors	1	-	2	1	-	-	1	1	X	A	TVNB
Tartaric Acid	-	-	2	2	-	-	1	1	A	A	TVNB
Titanium Tetrachloride	X	X	X	2	2	2	-	2	X	X	TV
Toluene	1	1	1	1	1	1	1	1	A	X	TVB
Tetrahydrofuran	X	-	2	1	1	-	1	2	A	X	T
Tomato Juice	2	-	3	2	3	2	2	2	X	A	TEVNB
Trichloroethylene	1	-	2	1	2	-	-	-	A	X	TV
Triethanolamine	2	X	2	2	2	2	2	2	A	X	TEVN
Triethylamine	-	-	-	-	-	2	2	2	A	X	TVB
Trisodium Phosphate (10%)	X	2	-	1	2	2	1	1	A	A	TVNB
Turpentine	2	X	2	2	2	1	1	1	X	X	TVB
Urea (50%)	2	-	2	-	2	2	2	2	A	A	TEVNB
Urine	-	-	-	-	2	-	1	1	X	A	TEVNB
Vinegar	2	X	2	2	2	2	2	2	X	A	TEVN
Water Acid (Mine)	X	X	X	1	X	-	-	-	X	A	TEVNB
Water (Distilled)	X	2	2	1	X	X	2	2	A	A	TEVNB
Water (Sea)	2	2	2	1	X	2	2	2	A	A	TEVNB
Whiskey	X	2	2	1	2	2	1	1	X	A	TEVNB
White Liquor (Pulp)	2	-	X	2	X	X	2	2	X	A	TEVNB
Wine	X	2	2	1	X	2	1	1	X	A	TEVNB
Xylene	2	2	2	1	2	2	2	2	A	X	TV
Zinc											
Zinc Chloride	X	X	X	2	X	-	X	2	A	A	TEVNB
Zinc Nitrate	-	-	-	-	-	-	2	2	X	A	TEVNB
Zinc Sulphate (50%)	X	2	2	2	X	2	1	1	X	A	TEVNB

Measurement & Conversion Information

Measures of Pressure

1 Pound Per Square Inch = 144 Pounds Per Square Foot = 0.068 Atmosphere = 2.042 Inches of Mercury at 62°F
= 27.7 Inches of Water at 62°F = 2.31 Feet of Water at 62°F.

1 Atmosphere = 30 Inches of Mercury at 62°F = 14.7 Pounds Per Square Inch = 2116.3 Pounds Per Square Foot
= 33.95 Feet of Water at 62°F.

1 Foot of Water at 62°F = 62.355 Pounds Per Square Foot = 0.433 Pounds Per Square Inch.

1 Inch of Mercury at 62°F = 1.132 Feet of Water = 13.58 Inches of Water = 0.491 Pounds Per Square Inch.

Column of Water 12 Inches High, 1 Inch in Diameter = 0.341 Pounds.

Length Conversion Constants

Millimetres x .039370 = Inches

Meters x 39.370 = Inches

Meters x 3.2808 = Feet

Meters x 1.09361 = Yards

Kilometres x 3,280.8 = Feet

Kilometres x .62137 = Statute Mile

Kilometres x .53959 = Nautical Miles

Inches x 25.4001 = Millimetres

Inches x .0254 = Meters

Feet x .30480 = Meters

Yards x .91440 = Meters

Feet x .0003048 = Kilometres

Statute Miles x 1.60935 = Kilometres

Nautical Miles x 1.85325 = Kilometres

Weight Conversion Constants

Grams x .03527 = Ounces (Avd.)

Grams x .033818 = Fluid Ounces (Water)

Kilograms x 35.27 = Ounces (Avd.)

Kilograms x 2.20462 = Pounds (Avd.)

Ounces (Avd.) x 28.35 = Grams

Fluid Ounces (Water) x 29.57 = Grams

Ounces (Avd.) x .02835 = Kilograms

Pounds (Avd.) x .45359 = Kilograms

Pressure Conversions

100 psi = 6.9 bars

600 psi = 41.4 bars

10 bars = 145 psi

250 psi = 17.25 bars

5 bars = 72.5 psi

25 bars = 362.5 psi



Fraction - Decimal Conversion Chart

	Inches	Millimetres
$\frac{1}{32}$.015625	.3969
$\frac{1}{16}$.03125	.7938
$\frac{3}{32}$.046875	1.1906
$\frac{1}{8}$.0625	1.5875
$\frac{5}{32}$.078125	1.9844
$\frac{3}{16}$.09375	2.3813
$\frac{7}{32}$.109375	2.7781
$\frac{1}{4}$.125	3.1750
$\frac{9}{32}$.140625	3.5719
$\frac{5}{16}$.15625	3.9688
$\frac{11}{32}$.171875	4.3656
$\frac{3}{8}$.1875	4.7625
$\frac{13}{32}$.203125	5.1594
$\frac{7}{16}$.21875	5.5563
$\frac{15}{32}$.234375	5.9531
$\frac{1}{2}$.250	6.3500
$\frac{9}{16}$.265625	6.7469
$\frac{17}{32}$.28125	7.1438
$\frac{19}{32}$.296875	7.5406
$\frac{5}{8}$.3125	7.9375
$\frac{21}{32}$.328125	8.3344
$\frac{11}{16}$.34375	8.7313
$\frac{23}{32}$.359375	9.1282
$\frac{3}{4}$.375	9.5250
$\frac{25}{32}$.390625	9.9219
$\frac{13}{16}$.40625	10.3188
$\frac{27}{32}$.421875	10.7157
$\frac{7}{8}$.4375	11.1125
$\frac{29}{32}$.453125	11.5094
$\frac{15}{8}$.46875	11.9063
$\frac{31}{32}$.484375	12.3032
1	.500	12.7001

	Inches	Millimetres
$\frac{17}{32}$.515625	13.0969
$\frac{9}{16}$.53125	13.4938
$\frac{35}{64}$.546875	13.8907
$\frac{37}{64}$.5625	14.2876
$\frac{19}{32}$.578125	14.6844
$\frac{39}{64}$.59375	15.0813
$\frac{5}{8}$.609375	15.4782
$\frac{41}{64}$.625	15.8751
$\frac{21}{32}$.640625	16.2719
$\frac{43}{64}$.65625	16.6688
$\frac{11}{16}$.671875	17.0657
$\frac{45}{64}$.6875	17.4626
$\frac{23}{32}$.703125	17.8594
$\frac{47}{64}$.71875	18.2563
$\frac{3}{4}$.734375	18.6532
$\frac{49}{64}$.750	19.0501
$\frac{25}{32}$.765625	19.4470
$\frac{51}{64}$.78125	19.8438
$\frac{13}{16}$.796875	20.2407
$\frac{53}{64}$.8125	20.6376
$\frac{27}{32}$.828125	21.0345
$\frac{55}{64}$.84375	21.4313
$\frac{7}{8}$.859375	21.8282
$\frac{57}{64}$.875	22.2251
$\frac{29}{32}$.890625	22.6220
$\frac{59}{64}$.90625	23.0188
$\frac{15}{16}$.921875	23.4157
$\frac{61}{64}$.9375	23.8126
$\frac{31}{32}$.953125	24.2095
$\frac{63}{64}$.96875	24.6063
1	.984375	25.0032
	1.000	25.4001

Temperature Conversions

Look up reading in middle column (shaded). If in degrees Centigrade, read Fahrenheit equivalent in right-hand column; if in degrees Fahrenheit, read Centigrade equivalent in left-hand column.

°C	°F	°C	°F	°C	°F	°C	°F	°C	°F	
-73	-100	-148		5.0	41	105.8		33.3	92	197.6
-68	-90	-130		5.6	42	107.6		33.9	93	199.4
-62	-80	-112		6.1	43	109.4		34.4	94	201.2
-57	-70	-94		6.7	44	111.2		35.0	95	203.0
-51	-60	-76		7.2	45	113.0		35.6	96	204.8
-46	-50	-58		7.8	46	114.8		36.1	97	206.6
-40	-40	-40		8.3	47	116.6		36.7	98	208.4
-34	-30	-22		8.9	48	118.4		37.2	99	210.2
-29	-20	-4		9.4	49	120.2		37.8	100	212.0
-23	-10	14		10.0	50	122.0				
-17.8	0	32		10.6	51	123.8		43	110	230
-17.2	1	33.8		11.1	52	125.6		49	120	248
-16.7	2	35.6		11.7	53	127.4		54	130	266
-16.1	3	37.4		12.2	54	129.2		60	140	284
-15.6	4	39.2		12.8	55	131.0		66	150	302
-15.0	5	41.0		13.3	56	132.8		71	160	320
-14.4	6	42.8		13.9	57	134.6		77	170	338
-13.9	7	44.6		14.4	58	136.4		82	180	356
-13.3	8	46.4		15.0	59	138.2		88	190	374
-12.8	9	48.2		15.6	60	140.0		93	200	392
-12.2	10	50.0		16.1	61	141.8		99	210	410
-11.7	11	51.8		16.7	62	143.6		100	212	413.6
-11.1	12	53.6		17.2	63	145.4		104	220	428
-10.6	13	55.4		17.8	64	147.2		110	230	446
-10.0	14	57.2		18.3	65	149.0		116	240	464
-9.4	15	59.0		18.9	66	150.8		121	250	482
-8.9	16	60.8		19.4	67	152.6		127	260	500
-8.3	17	62.6		20.0	68	154.4		132	270	518
-7.8	18	64.4		20.6	69	156.2		138	280	536
-7.2	19	66.2		21.1	70	158.0		143	290	554
-6.7	20	68.0		21.7	71	159.8		149	300	572
-6.1	21	69.8		22.2	72	161.6		154	310	590
-5.6	22	71.6		22.8	73	163.4		160	320	608
-5.0	23	73.4		23.3	74	165.2		166	320	626
-4.4	24	75.2		23.9	75	167.0		170	338	640
-3.9	25	77.0		24.4	76	168.8		171	340	644
-3.3	26	78.8		25.0	77	170.6		177	350	662
-2.8	27	80.6		25.6	78	172.4		182	360	680
-2.2	28	82.4		26.1	79	174.2		186	366	691
-1.7	29	84.2		26.7	80	176.0		188	370	698
-1.1	30	86.0		27.2	81	177.8		193	380	716
-0.6	31	87.8		27.8	82	179.6		198	388	730
0	32	89.6		28.3	83	181.4		199	390	734
.6	33	91.4		28.9	84	183.2		204	400	752
1.1	34	93.2		29.4	85	185.0		208	406	763
1.7	35	95.0		30.0	86	186.8		210	410	770
2.2	36	96.8		30.6	87	188.6		216	420	788
2.8	37	98.6		31.1	88	190.4		221	430	806
3.3	38	100.4		31.7	89	192.2		227	440	824
3.9	39	102.2		32.2	90	194.0		232	450	842
4.4	40	104.0		32.8	91	195.8				

Fittings Size Chart

Male NPT Thread Sizes

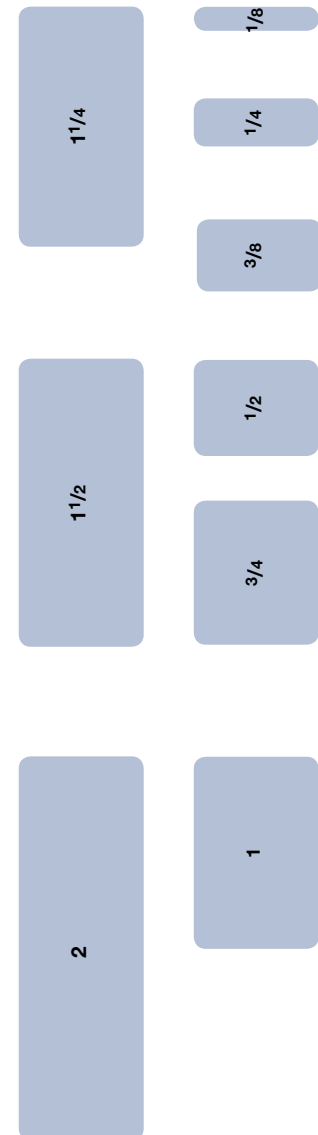

Male NST Thread Sizes



Steam Temperature - Pressure Conversion Guide

TEMPERATURE		LBS. PER SQ. INCH	TEMPERATURE		LBS. PER SQ. INCH	TEMPERATURE		LBS. PER SQ. INCH
°F	°C		°F	°C		°F	°C	
212	100.0	0.0	286	141.1	39.4	336	168.9	97.1
214	101.1	0.6	287	141.7	40.3	337	169.4	98.7
216	102.2	1.2	288	142.2	41.1	338	170.0	100.2
218	103.3	1.8	289	142.8	42.0	339	170.6	101.8
220	104.4	2.5	290	143.3	42.9	340	171.1	103.3
222	105.6	3.2	291	143.9	43.8	341	171.7	105.0
224	106.7	3.9	292	144.4	44.7	342	172.2	106.5
226	107.8	4.6	293	145.0	45.6	343	172.8	108.2
228	108.9	5.3	294	145.6	46.5	344	173.3	109.8
230	110.0	6.1	295	146.1	47.5	345	173.9	111.5
232	111.1	6.9	296	146.7	48.4	346	174.4	113.1
234	112.2	7.7	297	147.2	49.4	347	175.0	114.8
236	113.3	8.5	298	147.8	50.3	348	175.6	116.5
238	114.4	9.4	299	148.3	51.3	349	176.1	118.2
240	115.6	10.3	300	148.9	52.3	350	176.7	119.9
242	116.7	11.2	301	149.4	53.4	352	177.8	123.5
244	117.8	12.1	302	150.0	54.4	354	178.9	127.1
246	118.9	13.1	303	150.6	55.4	356	180.0	130.8
248	120.0	14.1	304	151.1	56.4	358	181.1	134.5
250	121.1	15.1	305	151.7	57.5	360	182.2	138.3
252	122.2	16.2	306	152.2	58.6	362	183.3	142.3
254	123.3	17.3	307	152.8	59.7	364	184.4	146.2
256	124.4	18.4	308	153.3	60.7	366	185.6	150.3
258	125.6	19.6	309	153.9	61.9	368	186.7	154.4
260	126.7	20.7	310	154.4	63.0	370	187.8	158.7
261	127.2	21.4	311	155.0	64.2	372	188.9	163.0
262	127.8	22.0	312	155.6	65.3	374	190.0	167.4
263	128.3	22.6	313	156.1	66.5	376	191.1	171.9
264	128.9	23.2	314	156.7	67.6	378	192.2	176.4
265	129.4	23.9	315	157.2	68.8	380	193.3	181.1
266	130.0	24.5	316	157.8	70.0	382	194.4	185.8
267	130.6	25.2	317	158.3	71.3	384	195.6	190.6
268	131.1	25.8	318	158.9	72.5	386	196.7	195.6
269	131.7	26.5	319	159.4	73.7	388	197.8	200.6
270	132.2	27.2	320	160.0	75.0	390	198.9	205.7
271	132.8	27.9	321	160.6	76.3	392	200.0	210.9
272	133.3	28.6	322	161.1	77.5	394	201.1	216.2
273	133.9	29.3	323	161.7	78.8	396	202.2	221.5
274	134.4	30.0	324	162.2	80.1	398	203.3	227.0
275	135.0	30.8	325	162.8	81.5	400	204.4	232.6
276	135.6	31.5	326	163.3	82.8	402	205.5	238
277	136.1	32.3	327	163.9	84.2	404	206.7	244
278	136.7	33.0	328	164.4	85.6	406	207.8	250
279	137.2	33.8	329	165.0	87.0	408	208.9	256
280	137.8	34.5	330	165.6	88.4	410	210	262
281	138.3	35.3	331	166.1	89.8	412	211.1	268
282	138.9	36.1	332	166.7	91.2	414	212.2	275
283	139.4	36.9	333	167.2	92.7	416	213.3	281
284	140.0	37.7	334	167.8	94.1	418	214.4	288
285	140.6	38.6	335	168.3	95.6	420	215.6	294

Coupling, Flange & Thread Information

It is important to identify the threads required before ordering couplings.

Identifying threads can sometimes be the most difficult and frustrating part of coupling selection. However, without the right combination of threads, you may not provide a functional or safe connection.

The diameters, threads per inch (TPI) and thread pitch, etc. are necessary to completely identify a thread. Ring, Plug and GO/NOGO gauges are required to accurately gauge or identify threads. In the field, in the absence of these gauges, thread leaf gauges can be used to identify the Threads Per Inch (TPI) and the thread pitch. On threads you have determined to be straight threads, a caliper can be used to measure the Outside Diameter of the Male (ODM) or the Inside Diameter of the Female (IDF). A caliper can also be used to take measurements of tapered thread diameters. However, these are more difficult to define because of the taper. Fortunately, there are few tapered threads to deal with and these can usually be identified from the nominal ODM and the TPI.

However, identifying the thread may not fully identify what is needed in a mating fitting. The application is the primary limiting factor on the thread type used. Dixon offers products with a wide variety of threads used with hose, pipe and hydraulics.

When attempting to choose a fitting, it is always advisable to first identify the thread to which it must connect. This may entail checking with a fitting or equipment manufacturer.

The fire hose thread specifications for some local municipal fire equipment and hydrants may vary according to local specifications. These can generally be most easily identified by contacting the local fire department responsible for the hydrant. The most common thread used on fire equipment is National Standard Thread (NST), also known as National Hose thread (NH).

When it is not possible to identify the thread:

- 1) Determine the number of threads per inch by measuring the distance from peak of thread to peak of thread across the largest number of whole threads. Then divide the number of threads by the measurement (This will provide the TPI).
- 2) Check to see if the thread is straight or tapered.
 - a) **Straight Threads** Measure the Outside Diameter of the Male (ODM) or the Inside Diameter of the Female (IDF), from peak of thread to peak of thread.
 - b) **Tapered Threads** Measure the Outside Diameter of the Male (ODM) at the large end and the small end, or the Inside Diameter of the Female (IDF) at the large end and the small end, from peak of thread to peak of thread. Then measure the Outside Diameter (OD) of the unthreaded pipe.

Once the application and these two pieces of information have been determined, the thread can generally be determined. When in doubt, contact the factory.

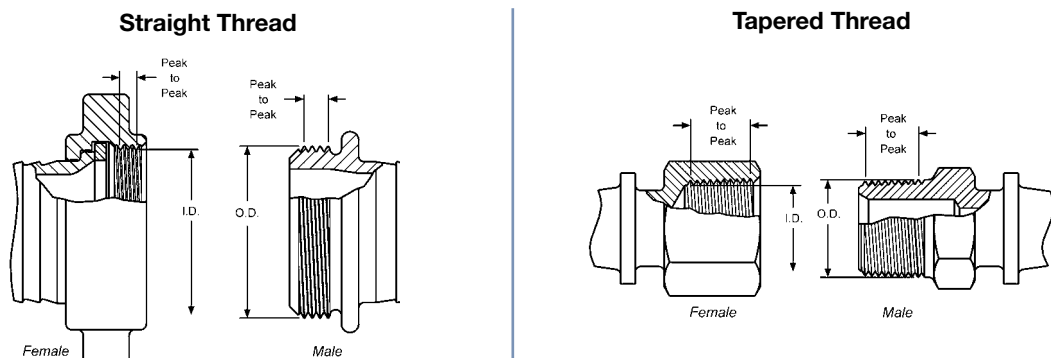

Threading Information

ABBREVIATION	SYSTEM NAME	COMPATABILITY	SEAL METHOD
BSPP	British Standard Pipe Parallel	Male BSPP with Female BSPP Female BSPP with Male BSPP Female BSPP with Male BSPT _r	Washer Washer Washer
BSPT_r	British Standard Pipe Taper	Male BSPT _r with Female BSPT _r Male BSPT _r with Female BSPP Female BSPT _r with Male BSPT _r <i>Female BSPT_r not compatible with Male BSPP</i>	Thread Washer Thread
CHT	American Standard Fire Hose Thread (1" National Hose Thread is Chemical Hose Thread, also known as Booster)	1" Male NH (NST) with 1" Female NH (NST) 1" Female NH (NST) with 1" Male NH (NST) 1" Thread is used on both 3/4" hose and 1" hose. <i>Not compatible with other systems</i>	Washer Washer
GHT	Garden Hose Thread	Male GHT with Female GHT Female GHT with Male GHT Thread is same for all size hose <i>Not compatible with other systems</i>	Washer Washer
IPS	Iron Pipe Straight Thread	Generic Name for Straight Pipe Thread See NPSH for compatibility	Washer
IPT	Iron Pipe Thread	Generic Name for All Pipe Thread <i>More information require</i>	
JIC	Joint Industrial Committee	Used with other mating JIC threads	Mechanical
NH or NST	American Standard Fire Hose Coupling Thread (National Hose thread also known as National Standard Thread)		Washer Washer
NPT	American Standard Taper Pipe Thread (National Pipe Tapered)	Male NPT with Female NPT Male NPT with Female NPTF Male NPT with Female NPSM Male NPT with Female NPSH Female NPT with Male NPT Female NPT with Male NPTF Female NPT not compatible with Male NPSM or Male NPSH	Thread Thread Washer Washer Thread Thread
NPFT	American Standard Taper Pipe Fuel Dryseal Thread (National Pipe Tapered) (Dryseal)	Male NPTF with Female NPTF Male NPTF with Female NPT Male NPTF with Female NPSM Male NPTF with Female NPSH Female NPTF with Male NPTF Female NPTF with Male NPT <i>Female NPTF with Male NPSM or NPSH</i> <i>Note: NPTF with NPTF threads do not require sealant for the initial use. After that, sealant is required.</i>	Thread Thread Washer Washer Thread Thread <i>Not Compatible</i>
NPSH	American Standard Straight Pipe for Hose Couplings (National Pipe Straight Hose)	Male NPSH with Female NPSH Female NPSH with Male NPSH Female NPSH with Male NPT Female NPSH with Male NPTF Female NPSH with Male NPSM	Washer Washer Washer Washer Washer
NPSM	American Standard Straight Mechanical Joints (National Pipe Straight Mechanical)	Male NPSM with Female NPSM Male NPSM with Female NPSH Female NPSM with Male NPSM Female NPSM with Male NPT Female NPSM with Male NPTF	Seal can be either mechanical or washer. Mating fittings must be of same type.
SIPT	Straight Iron Pipe Thread	Generic name for Straight Pipe Thread	Washer
TIPT	Tapered Iron Pipe Thread	Generic name for Tapered Pipe Thread	Thread
NYC	NYc Fire Department	Straight Thread used in New York City	Washer
Chicago	Chicago Fire Department	Straight Thread used in Chicago	Washer

Identifying Threads

Thread Seal Type

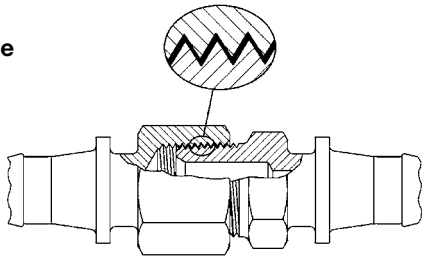

- A seal is obtained by applying a sealant to the male thread before engaging
- The sealant is used to prevent spiral leakage
- Thread tape or paste is the preferred sealant in this type of application
- Please refer to catalogue for thread tape options

Washer Seal Type

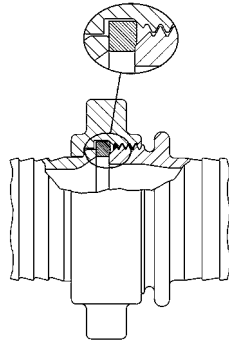

- A seal is obtained when the male thread is tightened down onto the washer of the female assembly
- The washer should be inspected regularly and replaced as needed to prevent leakage
- Please refer to catalogue for replacement washers

Mechanical Seal Type

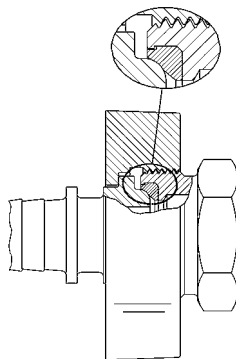

- A seal is obtained through metal to metal contact or metal to seal contact, i.e. JIC couplings have a metal to metal seal. EZ-Boss Ground Joint couplings have a metal to seal contact, (shown above)
- The couplings should be retightened as needed to prevent leakage

Thread Sealing Tips

Sealing N.P.T. threads can be an exasperating experience if certain techniques are not followed. The following tips will help alleviate many common problems in thread sealing:

1. Always use some type of sealant (tape or paste) and apply sealant to male thread only. If using a hydraulic sealant, allow sufficient curing time before system is pressurised.
 2. When using tape sealant, wrap the threads in a clock-wise motion starting at the first thread and, as layers are applied, work towards the imperfect (vanishing) thread. If the system that the connection being made to cannot tolerate foreign matter (i.e. air systems), leave the first thread exposed and apply the tape sealant as outlined above.
 3. When using paste sealant, apply to threads with a brush, using the brush to work the sealant into the threads. Apply enough sealant to fill in all the threads all the way around.
 4. When connecting one stainless steel part to another stainless steel part that will require future disassembly, use a thread sealant that is designed for stainless steel. This stainless steel thread sealant is also useful when connecting aluminium to aluminium that needs to be disconnected in the future. These two materials gall easily, and if the correct sealant is not used, it can be next to impossible to disassemble.
 5. When connecting parts made of dissimilar metals (i.e. steel and aluminium), standard tape or paste sealant performs satisfactory.
 6. For sizes 2" and below, tape or paste performs satisfactory. When using thread tape, four wraps (covering all necessary threads) is usually sufficient.
 7. For sizes 2" and above, thread paste is recommended. If thread tape is used, eight wraps (covering all necessary threads) is usually sufficient. Apply more wraps if necessary.
 8. For stubborn to seal threads, apply a normal coating of thread paste followed by a normal layer of thread tape.
 9. For extremely stubborn to seal threads, apply a normal coating of thread paste followed by a single layer of gauze bandage followed by a normal layer of thread tape.
- Caution!**
When this procedure is done, the connection becomes permanent. Extreme measures will be necessary to disconnect these components. All other measures to seal the threads should be explored prior to use of this technique.
10. Over-tightening threads can be just as detrimental as insufficient tightening. For sizes 2" and below, hand tighten the components and, with a wrench, tighten 3 full turns. For sizes 2" and above, hand tighten the components and, with a wrench, tighten 2 full turns.

Thread Dimensions

Nominal Dimensions of Standard Threads

ODM -- Outside Diameter of the Male

IDF -- Inside Diameter of the Female

TPI -- Threads Per Inch

		TAPERED THREADS		STRAIGHT THREADS											
		NPT	BSPT _r	NPSH				NPSM			NPT (NH)			BSPP	
SIZE	PIPE O.D.	TPI	TPI	TPI	ODM (MAX)	IDF (MIN)	TPI	ODM (MAX)	IDF (MIN)	TPI	ODM (MAX)	IDF (MIN)	TPI	ODM (MAX)	IDF (MIN)
1/8"	.405	27	28				27	0.397	0.358					0.383	0.337
1/4"	.504	18	19				18	0.526	0.468					0.516	0.450
3/8"	.675	18	19				18	0.662	0.603					0.656	0.588
1/2"	.840	14	14	14	0.8248	0.7395	14	0.823	0.747					0.825	0.733
3/4"	1.050	14	14	14	1.0353	0.9500	14	1.034	0.958	8	1.375	1.2246		1.041	0.950
1"	1.315	11.5	11	11.5	1.2951	1.1921	11.5	1.293	1.201	8	1.375	1.2246	11	1.309	1.193
1 1/4"	1.660	11.5	11	11.5	1.6399	1.5369	11.5	1.638	1.546				11	1.650	1.534
1 1/2"	1.900	11.5	11	11.5	1.8788	1.7758	11.5	1.877	1.785	9	1.990	1.8577		1.882	1.766
2"	2.375	11.5	11	11.5	2.3528	2.2498	11.5	2.351	2.259				11	2.347	2.231
2 1/2"	2.875	8	11	8	2.8434	2.6930	8	2.841	2.708	7.5	3.068	2.9104	11	2.960	2.844
3"	3.500	8	11				8	3.467	3.334	6	3.623	3.5306	11	3.460	3.344
4"	4.500	8	11				8	4.466	4.333	4	5.010	4.7111		4.450	4.334
4 1/2"										4	5.760	5.4611	11		
5"	5.563	8	11				8	5.528	5.395	4	6.260	5.9602	11	5.450	5.359
6"	6.625	8	11				8	6.585	6.452	4	7.025	6.7252		6.450	6.359
8"	8.625	8													
10"	10.750	8													
12"	12.750	8													

GHT (3/4") -- 1.0625 ODM, 11 1/2 TPI

Note: Female NPT (Tapered Pipe) thread is not available on hose swivel nuts.

Normal Engagement Length of NPT Thread in Inches ("A") *

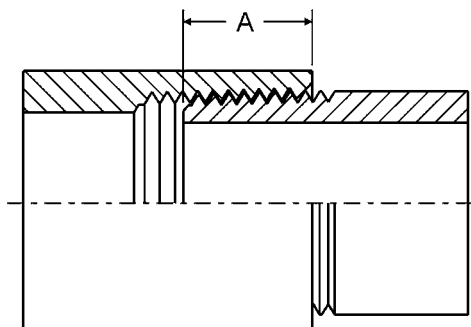

* Dimensions given do not allow for variations in tapping or threading.

THREAD SIZE	"A"
1/8"	1/4"
1/4"	3/8"
3/8"	3/8"
1/2"	1/2"
3/4"	9/16"
1"	11/16"
1 1/4"	11/16"
1 1/2"	11/16"
2"	3/4"

THREAD SIZE	"A"
2 1/2"	15/16"
3"	1"
4"	1 1/8"
5"	1 1/4"
6"	1 5/16"
8"	1 7/16"
10"	1 5/8"
12"	1 3/4"

Pipe and Flange Dimensions

Dimensions of Seamless and Welded Steel Pipe ASA-B36.10 and B36.19

NOMINAL PIPE SIZE	OUTSIDE DIAM	PIPE SCHEDULE WALL THICKNESS												
		10	20	30	STAND	40	60	EXTRA STRONG	80	100	120	140	160	XXXX STRONG
1/8"	0.405"	-	-	-	0.068	0.068	-	0.095	0.095	-	-	-	-	-
1/4"	0.540"	-	-	-	0.088	0.088	-	0.119	0.119	-	-	-	-	-
3/8"	0.675"	-	-	-	0.091	0.091	-	0.126	0.126	-	-	-	-	-
1/2"	0.840"	-	-	-	0.109	0.109	-	0.147	0.147	-	-	-	0.188	0.294
3/4"	1.050"	-	-	-	0.113	0.113	-	0.154	0.154	-	-	-	0.219	0.308
1"	1.315"	-	-	-	0.133	0.133	-	0.179	0.179	-	-	-	0.250	0.358
1 1/4"	1.660"	-	-	-	0.140	0.140	-	0.191	0.191	-	-	-	0.250	0.382
1 1/2"	1.900"	-	-	-	0.145	0.145	-	0.200	0.200	-	-	-	0.281	0.400
2"	2.375"	-	-	-	0.154	0.154	-	0.218	0.218	-	-	-	0.344	0.436
2 1/2"	2.875"	-	-	-	0.203	0.203	-	0.276	0.276	-	-	-	0.375	0.552
3"	3.500"	-	-	-	0.216	0.216	-	0.300	0.300	-	-	-	0.438	0.600
3 1/2"	4.000"	-	-	-	0.226	0.226	-	0.318	0.318	-	-	-	-	-----
4"	4.500"	-	-	-	0.237	0.237	-	0.337	0.337	-	0.438	-	0.531	0.674
5"	5.563"	-	-	-	0.258	0.258	-	0.375	0.375	-	0.500	-	0.625	0.750
6"	6.625"	-	-	-	0.280	0.280	-	0.432	0.432	-	0.562	-	0.719	0.864
8"	8.625"	-	0.250	0.277	0.322	0.322	0.406	0.500	0.500	0.594	0.719	0.812	0.906	0.873
10"	10.750"	-	0.250	0.307	0.365	0.365	0.500	0.500	0.594	0.719	0.844	1.000	1.125	1.000
12"	12.750"	-	0.250	0.330	0.375	0.406	0.562	0.500	0.688	0.844	1.000	1.125	1.312	1.000

Dimensions of 150 LB. ASA Steel Flanges

NOMINAL PIPE SIZE	FLANGE O.D.	THICKNESS*	O.D. OF RAISED FACE	DIAMETER OF BOLT CIRCLE	NUMBER OF BOLTS	DIAMETER OF BOLT HOLES	DIAMETER OF BOLTS
1"	4 1/2"	9/16"	2"	3 1/8"	4	5/8"	1/2"
1 1/2"	5"	11/16"	2 7/8"	3 7/8"	4	5/8"	1/2"
2"	6"	3/4"	3 5/8"	4 3/4"	4	3/4"	5/8"
2 1/2"	7"	7/8"	4 1/8"	5 1/2"	4	3/4"	5/8"
3"	7 1/2"	15/16"	5"	6"	4	3/4"	5/8"
4"	9"	15/16"	6 3/16"	7 1/2"	8	3/4"	5/8"
5"	10"	15/16"	7 5/16"	8 1/2"	8	7/8"	3/4"
6"	11"	1"	8 1/2"	9 1/2"	8	7/8"	3/4"
8"	13 1/2"	1 1/8"	10 5/8"	11 3/4"	8	7/8"	3/4"
10"	16"	1 3/16"	12 3/4"	14 1/4"	12	1"	7/8"
12"	19"	1 1/4"	15"	17"	12	1"	7/8"

* 1/16" raised face is included in the thickness.

Dimensions of Tank Truck Flanges (TTMA Drilling)

NOMINAL PIPE SIZE	FLANGE O.D.	THICKNESS*	DIAMETER OF BOLT CIRCLE	NUMBER OF BOLTS	DIAMETER OF BOLT HOLES	DIAMETER OF BOLTS
3"	5 5/8"	3/8"	4 7/8"	8	7/16"	3/8"
4"	6 5/8"	3/8"	5 7/8"	8	7/16"	3/8"
6"	8 7/8"	3/8"	8 1/8"	12	7/16"	3/8"

* Listed thickness is for aluminum flanges



Flange Information

Flange Bolt Tightening Sequence (Use appropriate gaskets and bolts)

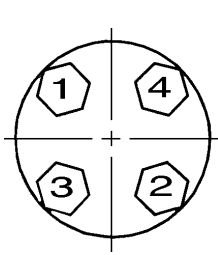

4 Bolt

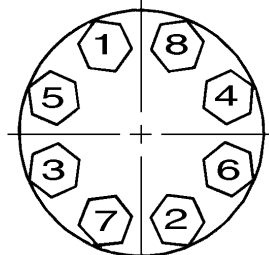

8 Bolt

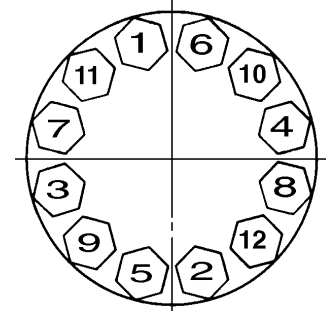

12 Bolt

Flange Diagrams

Threaded Applications

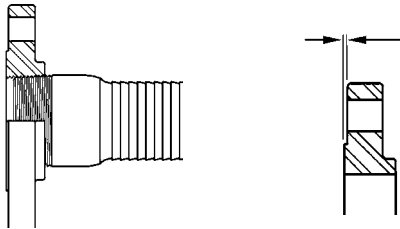

Threaded Flange with raised face

Welded Applications

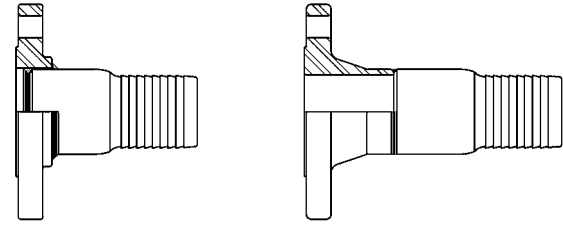

Slip-On Flange with raised face

Weld Neck Flange with raised face

Floating Applications (flange free to swivel)

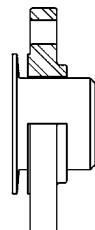

Slip-On Flange with raised face

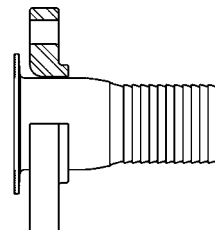

Lap-Joint Flange

Pressure - Temperature Ratings

Note: Ratings apply to all products covered by USA B16.5 valves conforming to the requirements of this standard must, in other respects, merit these ratings.

All ratings are maximum allowable non-shock pressures (psig) at the tabulated temperatures (degree Fahrenheit) and may be interpolated between temperatures shown. The primary service pressure ratings are shown in bold face type. Temperatures are those on the inside of the pressure retaining structure.

The use of these ratings requires gaskets conforming to the requirements of USA B16.5. The user is responsible for selecting gaskets of dimensions and materials to withstand the required bolt loading without injurious crushing, and suitable for the service conditions in all other respects.

PRESSURE CLASS	150	300
TEST PRESSURE	425	1100
SERVICE TEMP	PRESSURE	
-20 to 100	275	720
150	255	710
200	240	700
250	225	690
300	210	680
350	195	675
400	180	665
450	165	650
500	150	625
550	140	590
600	130	555
650	120	515
700	110	470
750	100	425

Maximum Recommended Air Flow (SCFM) Through ANSI Standard Weight Schedule 40 Pipe

The flow values in the table below are based on a pressure drop of 10% of the applied pressure per 100 feet of pipe for 1/8", 1/4", 3/8", and 1/2" pipe sizes; and a pressure drop of 5% of the applied pressure per 100 feet of pipe for 3/4", 1", 1 1/4", 2", 2 1/2", 3" pipe sizes. The table gives recommended flows for pipe sizes at listed pressures and should be used to determine appropriate piping for air systems.

APPLIED PRESSURE PSI	NOMINAL STANDARD PIPE SIZE										
	1/8"	1/4"	3/8"	1/2"	3/4"	1"	1 1/4"	1 1/2"	2"	2 1/2"	3"
5	0.5	1.2	2.7	4.9	6.6	13	27	40	80	135	240
10	0.8	1.7	3.9	7.7	11.0	21	44	64	125	200	370
20	1.3	3.0	6.6	13.0	18.5	35	75	110	215	350	600
40	2.5	5.5	12.0	23.0	34.0	62	135	200	385	640	1100
60	3.5	8.0	18.0	34.0	50.0	93	195	290	560	900	1600
80	4.7	10.5	23.0	44.0	65.0	120	255	380	720	1200	2100
100	5.8	13.0	29.0	54.0	80.0	150	315	470	900	1450	2600
150	8.6	20.0	41.0	80.0	115.0	220	460	680	1350	2200	3900
200	11.5	26.0	58.0	108.0	155.0	290	620	910	1750	2800	5000
250	14.5	33.0	73.0	135.0	200.0	370	770	1150	2200	3500	6100

Water Discharge Table

This table is intended for general reference and general applicability only, and should not be relied upon as the sole or precise source of information available with respect to the subject covered. The user should also refer to and follow manufacturer's specific instructions and recommendations with regard to such information, where they exist.

Flow of water through 100 foot lengths of hose, Straight-Smooth Bore - U.S. Gallons per minute

PSI AT HOSE INLET	NOMINAL HOSE I.D. DIAMETERS - INCHES							
	1"	1 1/4"	1 1/2"	2"	2 1/2"	3"	4"	6"
20	26	47	76	161	290	468	997	2895
30	32	58	94	200	360	582	1240	3603
40	38	68	110	234	421	680	1449	4209
50	43	77	124	264	475	767	1635	4748
60	47	85	137	291	524	846	1804	5239
75	53	95	154	329	591	955	2035	5910
100	62	112	180	384	690	1115	2377	6904
125	70	126	203	433	779	1258	2681	7788
150	77	139	224	478	859	1388	2958	8593
200	90	162	262	558	1004	1621	3455	10038

Figures are to be used as a guide since the hose inside diameter tolerance, the type of fittings used, and orifice restriction all influence the actual discharge. Thus, variations plus or minus from the table may be obtained in actual service.

Conversion Table - Feet of Water to Inches of Mercury

FEET OF WATER	1	2	4	6	8	10	12	14	16	20	22	24	26	28	30	32	34
INCHES OF MERCURY	0.9	1.8	3.5	5.3	7.1	8.8	10.6	12.4	14.1	17.7	19.4	21.2	23.0	24.8	26.5	28.3	30.0

Force Chart

Force (In Pounds)

HOSE I.D.	25 (PSI)	50 (PSI)	75 (PSI)	100 (PSI)	150 (PSI)	200 (PSI)	250 (PSI)	300 (PSI)	500 (PSI)	1000 (PSI)
1/4"	1	2	4	5	7	10	12	15	25	49
3/8"	3	6	8	11	17	22	28	33	55	110
1/2"	5	10	15	20	29	39	49	59	98	196
3/4"	11	22	33	44	66	88	110	133	221	442
1"	20	39	59	79	118	157	196	236	393	785
1 1/4"	31	61	92	123	184	245	307	368	614	1227
1 1/2"	44	88	133	177	265	353	442	530	884	1767
2"	79	157	236	314	471	628	785	942	1571	3142
2 1/2"	123	245	368	491	736	982	1227	1473	2454	4909
3"	177	353	530	707	1060	1414	1767	2121	3534	7069
4"	314	628	942	1257	1885	2513	3142	3770	6283	12566
5"	491	982	1473	1964	2945	3927	4909	5891	9818	19635
6"	707	1414	2121	2827	4241	5655	7069	8482	14137	28274
8"	1257	2513	3770	5027	7540	10053	12566	15080	25133	50266
10"	1964	3927	5891	7854	11781	15708	19635	23562	39270	78540
12"	2827	5655	8482	11310	16965	22620	28274	33929	56549	113098

Note: For hose I.D.'s from 1 1/4" to 12" the force in pounds is greater than the psi.

Force is the dynamic power which is exported longitudinally through a hose, towards the ends.

To arrive at the number of pounds of force exerted, you merely multiply the area of the I.D. times the working pressure being used.

- Area of a circle: $\pi \times r^2$ (PI [3.1416] times radius squared)
- Force = Area x Pressure

Cam and Groove Nominal Take-Up Lengths

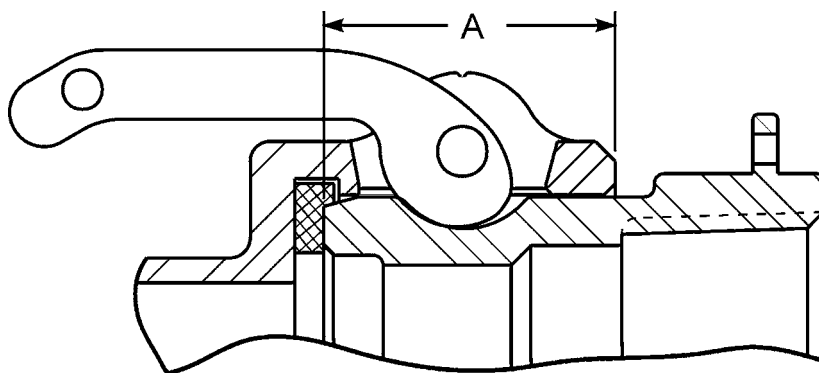

THREAD SIZE	"A"
1/2"	0.97"
3/4"	0.97"
1"	1.20"
1 1/4"	1.44"
1 1/2"	1.50"
2"	1.81"
2 1/2"	1.82"

THREAD SIZE	"A"
3"	1.78"
4"	1.84"
5"	2.00"
6"	2.13"
8"	2.06"
8"	3.22"

Boss-Lock Andrews

Bolt Tightening Sequence for Dixon Boss Clamps

NOTE:

1. The correct size Boss clamp must be used.
2. Bolts in Boss clamps are designed to bend as they are tightened.
This allows the clamp to conform to the hose outside diameter.
3. Always tighten bolts to their specified torque value.
4. Periodic re-tightening of bolts is required due to “cold flow” phenomenon present in all rubber hoses.
5. Boss Clamps are for single use only! Once removed they are to be discarded.

2 Bolt Dixon Boss Clamp Bolt Tightening Sequence

Using a torque wrench, begin tightening the bolts as follows:

- a) First bolt (nut facing assembler) 1 full turn
- b) Second bolt (opposite first bolt) 1 full turn
- c) Repeat procedure “a” and “b” until both bolts have reached the recommended torque
- d) Remove assembly from vice

4 Bolt Dixon Boss Clamp Bolt Tightening Sequence

Using a torque wrench, begin tightening the bolts as follows:

- a) Back bolt (bolt with nut facing assembler that is furthest away from gripping finger) 1 full turn
- b) Front bolt (bolt with nut facing assembler that is closest to gripping finger) 1 full turn
- c) Snug by hand (if bolts are loose) nuts on opposite side of bolts just torqued
- d) Opposite side back bolt (bolt with nut facing assembler furthest away from gripping finger) 1 full turn
- e) Opposite side front bolt (bolt with nut facing assembler closest to gripping finger) 1 full turn
- f) Snug by hand (if bolts are loose) nuts on opposite side of bolts just torqued
- g) Repeat above procedure “a” through “f” until all of the bolts have reached the recommended torque
- h) Remove assembly from vice

6 Bolt Dixon Boss Clamp Bolt Tightening Sequence

Using a torque wrench, begin tightening the bolts as follows:

- a) Back bolt (bolt with nut facing assembler that is furthest away from gripping finger) having “X” near it one full turn
- b) Front bolt (bolt with nut facing assembler that is closest to gripping finger) of same segment one full turn
- c) Moving to clamp segment to the left of the one just tightened, snug bolts by hand (if bolts are loose)
- d) Back bolt to one full turn
- e) Front bolt one full turn
- f) Moving to clamp segment to the left of the one just tightened, snug bolts by hand (if bolts are loose)
- g) Back bolt one full turn
- h) Front bolt one full turn
- i) Repeat above procedure “a” through “h” until all of the bolts have reached the recommended torque
- j) Remove assembly from vice.

CFM vs PSI for Nozzles

GAUGE (PSI)	CFM FREE AIR FLOW @ NOZZLE DIAMETER (INCH)							
	1/64	1/32	3/64	1/16	3/32	1/8	3/16	1/4
1	.03	.11	.2	.4	1.0	1.7	3.9	6.8
5	.06	.24	.5	1.0	2.2	3.9	8.7	15.4
10	.08	.34	.8	1.4	3.1	5.4	12.3	21.8
15	.10	.42	.9	1.6	3.7	6.6	15.0	26.7
20	.12	.48	1.1	1.9	4.2	7.7	17.1	30.8
25	.13	.54	1.2	2.2	4.7	8.6	19.4	34.5
30	.16	.63	1.4	2.5	5.6	10.0	22.5	40.0
40	.19	.77	1.7	3.1	6.8	12.3	27.5	49.1
50	.22	.91	2.0	3.6	8.2	14.5	32.8	58.2
60	.26	1.05	2.3	4.2	9.4	16.8	37.5	67.0
70	.29	1.19	2.7	4.8	10.7	19.0	43.0	76.0
80	.33	1.33	3.0	5.3	11.9	21.2	47.5	85.0
90	.36	1.47	3.3	5.9	13.1	23.5	52.5	94.0
100	.40	1.61	3.7	6.4	14.5	25.8	58.3	103.0
110	.43	1.76	3.9	7.0	15.7	28.0	63.0	112.0
120	.47	1.90	4.30	7.6	17.0	30.2	68.0	121.0
130	.50	2.04	4.6	8.1	18.2	32.4	73.0	130.0
140	.54	2.17	4.9	8.7	19.5	34.5	78.0	138.0
150	.57	2.33	5.2	9.2	20.7	36.7	83.0	147.0
175	.66	2.65	5.9	10.6	23.8	42.1	95.0	169.0
200	.76	3.07	6.9	12.2	27.5	48.7	110.0	195.0

PSI = pounds/square inch; CFM = cubic feet/minute

Water Data and Formulas

1 gallon water = 231 cubic inches = 8.333 pounds

1 pound of water = 27.7 cubic inches

1 cubic foot water = 7.5 gallons = 62.5 pounds
(salt water weighs approximately 64.3 pounds per cubic foot)

Pounds per square inch at bottom of a column of water = height of column in feet x .434

1 miner's inch = 9 to 12 gallons per minute

Horsepower to Raise Water

If pumping liquid other than water, multiply the gallons per minute below by the liquids specific gravity

$$\text{Horsepower} = \frac{\text{gallons per minute} \times \text{total head in feet}}{3960}$$

DISTANCE (INCHES)	GALLONS PER MINUTE DISCHARGE FOR A GIVEN NOMINAL PIPE DIAMETER (INCHES)				
	5	6	8	10	12
5	163	-	-	-	-
6	195	285	-	-	-
7	228	334	580	-	-
8	260	380	665	1060	-
9	293	430	750	1190	1660
10	326	476	830	1330	1850
11	360	525	915	1460	2020
12	390	570	1000	1600	2220
13	425	620	1080	1730	2400
14	456	670	1160	1860	2590
15	490	710	1250	2000	2780
16	520	760	1330	2120	2960
17	550	810	1410	2260	3140
18	590	860	1500	2390	3330
19	620	910	1580	2520	3500
20	650	950	1660	2660	3700
21	685	1000	1750	2800	3890
22	720	1050	1830	2920	4060
23	750	1100	1910	3060	4250
24	-	1140	2000	3200	4440

Gallons Per Minute through a Pipe

GPM = .0408 x pipe diameter inches² x feet/minute water velocity

Weight of Water in a Pipe

Pounds water = pipe length feet x pipe diameter inches² x .34

Formulas

Air Velocity in a Pipe

Using the equation and typical values of V, D and L explained to the right approximate values of P are computed as follows:

VELOCITY FT/SEC	PIPE DIAMETER IN INCHES, 10' LONG				
	1	2	4	6	10
1	.0004	.0002	.0001	.00007	.00004
2	.0016	.0008	.0004	.00030	.00016
5	.0100	.0050	.0025	.00170	.0010
10	.0400	.0200	.0100	.00670	.0040
15	.0900	.0450	.0225	.01500	.0090
20	.1600	.0800	.0400	.02700	.0160
25	.2500	.1250	.0625	.04170	.0250
30	.3600	.1800	.0900	.06000	.0360

$$V = \sqrt{\frac{25,000 DP}{L}}$$

V = air velocity in feet per second

D = pipe inside diameter in inches

L = length of pipe in feet

P = pressure loss due to air friction in
ounces/square inch

formula from B.F.Sturtevant Company

Theoretical Horsepower to Compress Air

HP = compressed horsepower

CFM = air volume in cubic feet per minute

PSI = air pressure in pounds per square inch

(assumes atmospheric pressure = 14.7 psi, temperature = 60°F)

$$HP = CFM \times PSI \times .0007575$$

Air Volume Discharged from Pipe

CFM = air volume in cubic feet per minute

V = air velocity in feet per second as determined in the
equation at the top of this page

A = cross section area of pipe in square feet

$$CFM = 60VA$$

Boyle's Law

If temperature is kept constant, the volume of a given mass of gas is inversely proportional to the pressure which is exerted upon it.

$$\frac{\text{Initial Pressure}}{\text{Final Pressure}} = \frac{\text{Final Volume}}{\text{Initial Volume}}$$

Circumference of a Circle

If temperature is kept constant, the volume of a given mass of gas is inversely proportional to the pressure which is exerted upon it.

$$\text{Circumference} = 2\pi r = \pi d = 3.14159d$$

$$\text{Area} = \pi r^2 = \frac{d^2}{4} = .78539d^2$$

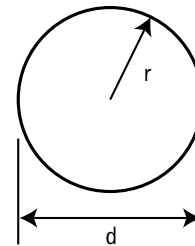

Right Cylinder

r = radius

h = length

$$\text{Volume} = \pi r^2 h$$

$$\text{Surface Area} = 2\pi r(r+h)$$

If end planes are parallel but not at 90° to h, the same formulas apply, but a slice at 90° through the cylinder must be used to determine r.

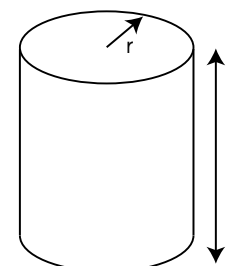

Crimped Air King Recommendation Guide

The chart at the right is only a guide. It will not apply to every coupling situation. In some instances alternative dies and crimping dimensions must be employed to ensure safety. Experience has shown that variances in the construction of similar hoses and couplings may cause some assemblies to react differently when crimped. It is not uncommon to find hose with an outer diameter that fluctuates from one end to the other or from production lot to production lot. These inconsistencies coupled with the inherent differences between textile or wire braid, hard or soft wall, the presence or absence of an internal spiral wire and the differences in hose coverings make it difficult to establish hard and fast rules. Therefore, its imperative that hose dimensions are accurately measured, assemblies are tested, and documentation is maintained.

HOSE SIZE	PART NO	FRACTIONAL HOSE O.D.	SWAGE DIE SIZES	DIE PART NO	CRIMP DIAMETER	% REDUCTION	
Size (I.D.): Crimped Length: 1/2"	AM1WF	54/64	13/16 x 29/32	1 & 3/16 D4	0.906	18.3%	
		55/64	13/16 x 15/16	1 & 3/16 D5	0.937	13.2%	
		56/64					16.9%
		57/64	13/16 x 31/16	1 & 3/16 D3	0.968	12.1%	
		58/64					15.5%
		59/64	13/16 x 1	1 & 3/16 D	1.000	11.1%	
		60/64					14.4%
		61/64					17.2%
		62/64	13/16 x 1/32	1 & 3/16 D2	1.031	13.4%	
		63/64					16.1%
Size (I.D.): 3/4"	AM6WF and RAM6WF	1	13/16 x 1/16	1 & 3/16 D1	1.062	12.7%	
		11/64					15.3%
		12/64	13/16 x 3/32	1 & 3/16 D6	1.093	12.0%	
		14/64	1 1/2 x 5/32	1 & 1/2 D6	1.156	13.4%	
		15/64					17.3%
		16/64	1 1/2 x 3/16	1 & 1/2 D7	1.187	11.9%	
		17/64					15.8%
		18/64	1 1/2 x 7/32	1 & 1/2 D5	1.218	11.2%	
		19/64					14.6%
		110/64					17.5%
Size (I.D.): 3/4"	AM6WF and RAM6WF	111/64	1 1/2 x 1/4	1 & 1/2 D4	1.250	13.0%	
		112/64					16.2%
		113/64	1 1/2 x 9/32	1 & 1/2 D3	1.281	12.3%	
		114/64					15.1%
		115/64	1 1/2 x 5/16	1 & 1/2 D2	1.312	11.5%	
		116/64					14.4%
		117/64					16.9%
		118/64	1 1/2 x 11/32	1 & 1/2 D	1.343	13.5%	
		119/64					15.9%
		120/64	1 1/2 x 13/8	1 & 1/2 D1	1.375	12.6%	
Size (I.D.): 1"	AM11WF-1	121/64				15.0%	
		122/64	1 1/2 x 113/32	1 & 1/2 D8	1.406	12.1%	
		118/64	1 11/16 x 13/8	1 & 11/16 D4	1.375	16.7%	
		119/64					20.5%
		120/64	1 11/16 x 113/32	1 & 11/16 D5	1.406	15.0%	
		121/64					18.6%
		122/64	1 11/16 x 17/16	1 & 11/16 D8	1.437	13.7%	
		123/64					17.5%
		124/64	1 11/16 x 17/16	1 & 11/16 D6	1.468	12.8%	
		125/64					16.1%
Size (I.D.): 1"	AM11WF and AM11WF-1	126/64	1 11/16 x 1 1/2	1 & 11/16 D	1.500	11.5%	
		127/64					14.7%
		128/64					17.6%
		129/64	1 11/16 x 117/32	1 & 11/16 D2	1.531	13.9%	
		130/64	1 7/8 x 117/32	1 & 7/8 D8	1.531	16.8%	
		131/64	1 7/8 x 19/16	1 & 7/8 D5	1.562	12.8%	
		132/64					15.4%
		133/64	1 7/8 x 119/32	1 & 7/8 D6	1.593	12.0%	
		134/64					14.7%
		Crimped Length: 1"	AM11WF	135/64	1 7/8 x 15/8	1 & 7/8 D7	1.625
136/64							13.7%
137/64							15.9%
138/64	1 7/8 x 121/32			1 & 7/8 D1	1.656	12.9%	
139/64							15.1%
140/64	1 7/8 x 111/16			1 & 7/8 D	1.687	12.4%	
141/64							14.5%
142/64	1 7/8 x 123/32			1 & 7/8 D2	1.718	11.8%	
143/64							14.0%
144/64	1 7/8 x 13/4			1 & 7/8 D4	1.750	11.3%	
145/64					13.3%		
146/64					15.1%		

The charts below are only guides. They will not apply to every coupling situation. In some instances alternative dies and crimping dimensions must be employed to ensure safety. Experience has shown that variances in the construction of similar hoses and couplings may cause some assemblies to react differently when crimped. It is not uncommon to find hose with an outer diameter that fluctuates from one end to the other or from production lot to production lot. These inconsistencies coupled with the inherent differences between textile or wire braid, hard or soft wall, the presence or absence of an internal spiral wire and the differences in hose coverings make it difficult to establish hard and fast rules. Therefore, it is imperative that hose dimensions are accurately measured, assemblies are tested, and documentation is maintained.

Crimped Dix-Lock and Dual-Lock Recommendation Guide

PART NO QM3WF, QB3WF, QM22WF, QB22WF, QM33WF, QB33WF					PART NO QM4WF, QB4WF, QM23WF, QB23WF, QM44WF, QB44WF				
HOSE I.D.	MEASURED HOSE O.D.		CRIMP LENGTH	DIX-LOCK CRIMP O.D. + .005	HOSE I.D.	MEASURED HOSE O.D.		CRIMP LENGTH	DIX-LOCK CRIMP O.D. + .005
	FRACTIONAL	DECIMAL				FRACTIONAL	DECIMAL		
1/2"	54/64"	0.844	1 1/8"	0.968	3/4"	110/64"	1.156	1 1/4"	1.218
1/2"	55/64"	0.859	1 1/8"	0.968	3/4"	111/64"	1.172	1 1/4"	1.218
1/2"	56/64"	0.875	1 1/8"	0.968	3/4"	112/64"	1.188	1 1/4"	1.218
1/2"	57/64"	0.891	1 1/8"	1.000	3/4"	113/64"	1.203	1 1/4"	1.250
1/2"	58/64"	0.906	1 1/8"	1.000	3/4"	114/64"	1.219	1 1/4"	1.250
1/2"	59/64"	0.922	1 1/8"	1.031	3/4"	115/64"	1.234	1 1/4"	1.281
1/2"	60/64"	0.938	1 1/8"	1.031	3/4"	116/64"	1.250	1 1/4"	1.281
1/2"	61/64"	0.953	1 1/8"	1.062	3/4"	117/64"	1.266	1 1/4"	1.281
1/2"	62/64"	0.969	1 1/8"	1.062	3/4"	118/64"	1.281	1 1/4"	1.312
1/2"	63/64"	0.984	1 1/8"	1.062	3/4"	119/64"	1.297	1 1/4"	1.312
1/2"	1"	1.000	1 1/8"	1.093	3/4"	120/64"	1.313	1 1/4"	1.343
1/2"	1 1/64"	1.016	1 1/8"	1.093	3/4"	121/64"	1.328	1 1/4"	1.343
1/2"	1 2/64"	1.031	1 1/8"	1.093	3/4"	122/64"	1.344	1 1/4"	1.375

Crimped 3500 Nipple Recommendation Guide

SMOD = 1/2"				SMOD = 3/4"				SMOD = 1"			
HOSE O.D.	DIE	CRIMP DIA.	% RED	HOSE O.D.	DIE	CRIMP DIA.	% RED	HOSE O.D.	DIE	CRIMP DIA.	% RED
54/64"	1 1/16 x 29/32	.906	21.1	110/64"	1 3/8 x 13/16	1.188	24.1	130/64"	1 11/16 x 1 1/2	1.500	23
54/64"	1 1/16 x 29/32	.906	24.5	111/64"	1 3/8 x 17/32	1.219	19.5	131/64"	1 11/16 x 1 17/32	1.531	19
54/64"	1 1/16 x 15/16	.938	19.3	112/64"	1 3/8 x 17/32	1.219	22.4	132/64"	1 11/16 x 1 17/32	1.531	21.6
54/64"	1 1/16 x 15/16	.938	22.6	113/64"	1 7/16 x 1 1/4	1.250	18.1	133/64"	1 11/16 x 1 9/16	1.563	17.9
54/64"	1 1/8 x 31/32	.969	17.8	114/64"	1 7/16 x 1 1/4	1.250	20.9	134/64"	1 11/16 x 1 9/16	1.563	20.3

Dixon's couplings and retention devices are designed to work safely for their intended use. The selection of the proper hose, coupling, and retention devices; and the proper application of the coupling to the hose are of utmost importance. Users must consider the size, temperature, application, media, pressure, and hose and coupling manufacturer's recommendations when selecting the proper hose assembly components. Dixon recommends that all hose assemblies be tested in accordance with the Rubber Manufacturers Association's recommendations and be inspected regularly (before each use), to ensure that they are not damaged or have become loose.

Where safety devices are integral to the coupling, they must be working and utilised. The use of supplementary safety devices, such as safety clips and King Cable safety cables, are recommended. If any problem is detected, couplings must be removed from service immediately.

Dixon is always available for consultation concerning the couplings and accessories we sell. We will suggest the appropriate fittings, test those applications when necessary, and train distributors in assembly procedures. We strongly recommend that distributors and end users make use of these services.

CRIMPED RECOMMENDATION GUIDE

CAM & GROOVE COUPLER PART NO	CAM & GROOVE ADAPTER PART NO	KING COMBINATION NIPPLE PART NO	SLEEVE & FERRULE PART NO	HOSE ID	HOSE RANGE		HOSE OD	CRIMP DIAMETER (± 0.005)
					FROM	TO		
100-C-AL 100-C-BR 100-C-SS RC100EZCR G100-C-ALCR G100-C-BRCR G100-C-SSCR	100-E-AL 100-E-BR 100-E-SS G100-E-ALCR G100-E-BRCR G100-E-SSCR	ST10CS RST10CS STV10CS RSTV10CS STB10CS RSTB10CS	CS100-1xx CF100-1xx	1"	1 13/64	1 16/64	1 13/64	1.266
							1 14/64	1.278
							1 15/64	1.290
							1 16/64	1.303
			CS100-2xx CF100-2xx	1"	1 17/64	1 20/64	1 17/64	1.317
							1 18/64	1.329
							1 19/64	1.342
							1 20/64	1.354
			CS100-3xx CF100-3xx	1"	1 21/64	1 24/64	1 21/64	1.366
							1 22/64	1.378
							1 23/64	1.390
							1 24/64	1.403
CS100-4xx CF100-4xx	1"	1 25/64	1 28/64	1 25/64	1.419			
				1 26/64	1.431			
				1 27/64	1.443			
				1 28/64	1.456			
CS100-5xx CF100-5xx	1"	1 29/64	1 32/64	1 29/64	1.468			
				1 30/64	1.480			
				1 31/64	1.493			
				1 32/64	1.505			
CS100-6xx CF100-6xx	1"	1 33/64	1 36/64	1 33/64	1.517			
				1 34/64	1.530			
				1 35/64	1.542			
				1 36/64	1.554			
CS100-7xx CF100-7xx	1"	1 37/64	1 40/64	1 37/64	1.567			
				1 38/64	1.579			
				1 39/64	1.591			
				1 40/64	1.604			
CS100-8xx CF100-8xx	1"	1 41/64	1 44/64	1 41/64	1.616			
				1 42/64	1.628			
				1 43/64	1.641			
				1 44/64	1.653			
CS100-9xx CF100-9xx	1"	1 45/64	1 48/64	1 45/64	1.665			
				1 46/64	1.678			
				1 47/64	1.690			
				1 48/64	1.703			
CS100-10xx CF100-10xx	1"	1 49/64	1 52/64	1 49/64	1.715			
				1 50/64	1.727			
				1 51/64	1.740			
				1 52/64	1.752			

CRIMPED RECOMMENDATION GUIDE

CAM & GROOVE COUPLER PART NO	CAM & GROOVE ADAPTER PART NO	KING COMBINATION NIPPLE PART NO	SLEEVE & FERRULE PART NO	HOSE ID	HOSE RANGE		HOSE OD	CRIMP DIAMETER (± 0.005)
					FROM	TO		
150-C-AL 150-C-BR 150-C-SS RC150EZCR G150-C-ALCR G150-C-BRCR G150-C-SSCR	150-E-AL 150-E-BR 150-E-SS G150-E-ALCR G150-E-BRCR G150-E-SSCR	ST20CS RST20CS STV20CS RSTV20CS STB20CS RSTB20CS	CS150-1xx CF150-1xx	1 1/2"	1 13/64	1 44/64	1 41/64	1.726
							1 42/64	1.738
			CS150-2xx CF150-2xx	1 1/2"	1 45/64	1 48/64	1 43/64	1.749
							1 44/64	1.761
							1 45/64	1.778
			CS150-3xx CF150-3xx	1 1/2"	1 49/64	1 52/64	1 46/64	1.790
							1 47/64	1.802
							1 48/64	1.815
			CS150-4xx CF150-4xx	1 1/2"	1 53/64	1 56/64	1 49/64	1.829
							1 50/64	1.841
							1 51/64	1.854
			CS150-5xx CF150-5xx	1 1/2"	1 57/64	1 60/64	1 52/64	1.866
							1 53/64	1.878
							1 54/64	1.890
			CS150-6xx CF150-6xx	1 1/2"	1 61/64	2	1 55/64	1.902
							1 56/64	1.915
							1 57/64	1.931
			CS150-7xx CF150-7xx	1 1/2"	2 1/64	4/64	1 58/64	1.943
							1 59/64	1.955
							1 60/64	1.968
CS150-8xx CF150-8xx	1 1/2"	2 5/64	28/64	1 61/64	1.980			
				1 62/64	1.922			
				1 63/64	2.005			
CS150-9xx CF150-9xx	1 1/2"	2 9/64	2 12/64	2	2.017			
				2 1/64	2.029			
				2 2/64	2.042			
CS150-10xx CF150-10xx	1 1/2"	2 13/64	2 16/64	2 3/64	2.054			
				2 4/64	2.066			
				2 5/64	2.079			
CS150-11xx CF150-11xx	1 1/2"	2 17/64	2 20/64	2 6/64	2.091			
				2 7/64	2.103			
				2 8/64	2.116			
CS150-12xx CF150-12xx	1 1/2"	2 21/64	2 24/64	2 9/64	2.128			
				2 10/64	2.140			
				2 11/64	2.153			
CS150-13xx CF150-13xx	1 1/2"	2 25/64	2 28/64	2 12/64	2.165			
				2 13/64	2.177			
				2 14/64	2.190			
CS150-14xx CF150-14xx	1 1/2"	2 29/64	2 32/64	2 15/64	2.202			
				2 16/64	2.215			
				2 17/64	2.227			
CS150-15xx CF150-15xx	1 1/2"	2 33/64	2 36/64	2 18/64	2.239			
				2 19/64	2.252			
				2 20/64	2.264			
CS150-16xx CF150-16xx	1 1/2"	2 37/64	2 40/64	2 21/64	2.276			
				2 22/64	2.289			
				2 23/64	2.301			
CS150-17xx CF150-17xx	1 1/2"	2 41/64	2 44/64	2 24/64	2.313			
				2 25/64	2.326			
				2 26/64	2.339			

CRIMPED RECOMMENDATION GUIDE

CAM & GROOVE COUPLER PART NO	CAM & GROOVE ADAPTER PART NO	KING COMBINATION NIPPLE PART NO	SLEEVE & FERRULE PART NO	HOSE ID	HOSE RANGE		HOSE OD	CRIMP DIAMETER (± 0.005)
					FROM	TO		
200-C-AL 200-C-BR 200-C-SS RC200EZCR G200-C-ALCR G200-C-BRCR G200-C-SSCR	200-E-AL 200-E-BR 200-E-SS G200-E-ALCR G200-E-BRCR G200-E-SSCR	ST25CS RST25CS STV25CS RSTV25CS STB25CS RSTB25CS	CS200-1xx CF200-1xx	2"	2 ¹³ / ₆₄	2 ¹⁶ / ₆₄	2 ¹³ / ₆₄	2.278
							2 ¹⁴ / ₆₄	2.290
							2 ¹⁵ / ₆₄	2.302
							2 ¹⁶ / ₆₄	2.315
			CS200-2xx CF200-2xx	2"	2 ¹⁷ / ₆₄	2 ²⁰ / ₆₄	2 ¹⁷ / ₆₄	2.329
							2 ¹⁸ / ₆₄	2.341
							2 ¹⁹ / ₆₄	2.354
							2 ²⁰ / ₆₄	2.366
			CS200-3xx CF200-3xx	2"	2 ²¹ / ₆₄	2 ²⁴ / ₆₄	2 ²¹ / ₆₄	2.378
							2 ²² / ₆₄	2.390
							2 ²³ / ₆₄	2.402
							2 ²⁴ / ₆₄	2.415
			CS200-4xx CF200-4xx	2"	2 ²⁵ / ₆₄	2 ²⁸ / ₆₄	2 ²⁵ / ₆₄	2.431
							2 ²⁶ / ₆₄	2.443
							2 ²⁷ / ₆₄	2.455
							2 ²⁸ / ₆₄	2.468
			CS200-5xx CF200-5xx	2"	2 ²⁹ / ₆₄	2 ³² / ₆₄	2 ²⁹ / ₆₄	2.480
							2 ³⁰ / ₆₄	2.492
							2 ³¹ / ₆₄	2.505
							2 ³² / ₆₄	2.517
CS200-6xx CF200-6xx	2"	2 ³³ / ₆₄	2 ³⁶ / ₆₄	2 ³³ / ₆₄	2.529			
				2 ³⁴ / ₆₄	2.542			
				2 ³⁵ / ₆₄	2.554			
				2 ³⁶ / ₆₄	2.566			
CS200-7xx CF200-7xx	2"	2 ³⁷ / ₆₄	2 ⁴⁰ / ₆₄	2 ³⁷ / ₆₄	2.579			
				2 ³⁸ / ₆₄	2.591			
				2 ³⁹ / ₆₄	2.603			
				2 ⁴⁰ / ₆₄	2.616			
CS200-8xx CF200-8xx	2"	2 ⁴¹ / ₆₄	2 ⁴⁴ / ₆₄	2 ⁴¹ / ₆₄	2.628			
				2 ⁴² / ₆₄	2.640			
				2 ⁴³ / ₆₄	2.653			
				2 ⁴⁴ / ₆₄	2.665			
CS200-9xx CF200-9xx	2"	2 ⁴⁵ / ₆₄	2 ⁴⁸ / ₆₄	2 ⁴⁵ / ₆₄	2.677			
				2 ⁴⁶ / ₆₄	2.690			
				2 ⁴⁷ / ₆₄	2.702			
				2 ⁴⁸ / ₆₄	2.792			
CS200-10xx CF200-10xx	2"	2 ⁴⁹ / ₆₄	2 ⁵² / ₆₄	2 ⁴⁹ / ₆₄	2.727			
				2 ⁵⁰ / ₆₄	2.739			
				2 ⁵¹ / ₆₄	2.752			
				2 ⁵² / ₆₄	2.764			
CS200-11xx CF200-11xx	2"	2 ⁵³ / ₆₄	2 ⁵⁶ / ₆₄	2 ⁵³ / ₆₄	2.776			
				2 ⁵⁴ / ₆₄	2.789			
				2 ⁵⁵ / ₆₄	2.801			
				2 ⁵⁶ / ₆₄	2.813			
CS200-12xx CF200-12xx	2"	2 ⁵⁷ / ₆₄	2 ⁶⁰ / ₆₄	2 ⁵⁷ / ₆₄	2.826			
				2 ⁵⁸ / ₆₄	2.838			
				2 ⁵⁹ / ₆₄	2.850			
				2 ⁶⁰ / ₆₄	2.863			

CRIMPED RECOMMENDATION GUIDE

CAM & GROOVE COUPLER PART NO	CAM & GROOVE ADAPTER PART NO	KING COMBINATION NIPPLE PART NO	SLEEVE & FERRULE PART NO	HOSE ID	HOSE RANGE		HOSE OD	CRIMP DIAMETER (± 0.005)		
					FROM	TO				
300-C-AL 300-C-BR 300-C-SS RC300EZCR G300-C-ALCR G300-C-BRCR G300-C-SSCR	300-E-AL 300-E-BR 300-E-SS G300-E-ALCR G300-E-BRCR G300-E-SSCR	ST35CS RST35CS STV35CS RSTV35CS STB35CS RSTB35CS	CS300-1xx CF300-1xx	3"	3 ¹³ / ₆₄	3 ¹⁶ / ₆₄	3 ¹³ / ₆₄	3.333		
							3 ¹⁴ / ₆₄	3.345		
									3 ¹⁵ / ₆₄	3.357
									3 ¹⁶ / ₆₄	3.370
			CS300-2xx CF300-2xx	3"	3 ¹⁷ / ₆₄	3 ²⁰ / ₆₄	3 ¹⁷ / ₆₄	3.384		
							3 ¹⁸ / ₆₄	3.396		
							3 ¹⁹ / ₆₄	3.409		
							3 ²⁰ / ₆₄	3.421		
			CS300-3xx CF300-3xx	3"	3 ²¹ / ₆₄	3 ²⁴ / ₆₄	3 ²¹ / ₆₄	3.433		
							3 ²² / ₆₄	3.445		
							3 ²³ / ₆₄	3.457		
							3 ²⁴ / ₆₄	3.470		
			CS300-4xx CF300-4xx	3"	3 ²⁵ / ₆₄	3 ²⁸ / ₆₄	3 ²⁵ / ₆₄	3.486		
							3 ²⁶ / ₆₄	3.498		
							3 ²⁷ / ₆₄	3.510		
							3 ²⁸ / ₆₄	3.523		
CS300-5xx CF300-5xx	3"	3 ²⁹ / ₆₄	3 ³² / ₆₄	3 ²⁹ / ₆₄	3.535					
				3 ³⁰ / ₆₄	3.547					
				3 ³¹ / ₆₄	3.560					
				3 ³² / ₆₄	3.572					
CS300-6xx CF300-6xx	3"	3 ³³ / ₆₄	3 ³⁶ / ₆₄	3 ³³ / ₆₄	3.584					
				3 ³⁴ / ₆₄	3.597					
				3 ³⁵ / ₆₄	3.609					
				3 ³⁶ / ₆₄	3.621					
CS300-7xx CF300-7xx	3"	3 ³⁷ / ₆₄	3 ⁴⁰ / ₆₄	3 ³⁷ / ₆₄	3.634					
				3 ³⁸ / ₆₄	3.646					
				3 ³⁹ / ₆₄	3.658					
				3 ⁴⁰ / ₆₄	3.671					
CS300-8xx CF300-8xx	3"	3 ⁴¹ / ₆₄	3 ⁴⁴ / ₆₄	3 ⁴¹ / ₆₄	3.683					
				3 ⁴² / ₆₄	3.695					
				3 ⁴³ / ₆₄	3.708					
				3 ⁴⁴ / ₆₄	3.720					
CS300-9xx CF300-9xx	3"	3 ⁴⁵ / ₆₄	3 ⁴⁸ / ₆₄	3 ⁴⁵ / ₆₄	3.732					
				3 ⁴⁶ / ₆₄	3.745					
				3 ⁴⁷ / ₆₄	3.757					
				3 ⁴⁸ / ₆₄	3.770					
CS300-10xx CF300-10xx	3"	3 ⁴⁹ / ₆₄	3 ⁵² / ₆₄	3 ⁴⁹ / ₆₄	3.782					
				3 ⁵⁰ / ₆₄	3.794					
				3 ⁵¹ / ₆₄	3.807					
				3 ⁵² / ₆₄	3.819					
CS300-11xx CF300-11xx	3"	3 ⁵³ / ₆₄	3 ⁵⁶ / ₆₄	3 ⁵³ / ₆₄	3.831					
				3 ⁵⁴ / ₆₄	3.844					
				3 ⁵⁵ / ₆₄	3.856					
				3 ⁵⁶ / ₆₄	3.868					
CS300-12xx CF300-12xx	3"	3 ⁵⁷ / ₆₄	3 ⁶⁰ / ₆₄	3 ⁵⁷ / ₆₄	3.881					
				3 ⁵⁸ / ₆₄	3.893					
				3 ⁵⁹ / ₆₄	3.905					
				3 ⁶⁰ / ₆₄	3.918					
CS300-13xx CF300-13xx	3"	3 ⁶¹ / ₆₄	4	3 ⁶¹ / ₆₄	3.930					
				3 ⁶² / ₆₄	3.942					
				3 ⁶³ / ₆₄	3.955					
				4	3.967					
CS300-14xx CF300-14xx	3"	4 ¹ / ₆₄	4 ⁴ / ₆₄	4 ¹ / ₆₄	3.979					
				4 ² / ₆₄	3.992					
				4 ³ / ₆₄	4.004					
				4 ⁴ / ₆₄	4.016					
CS300-15xx CF300-15xx	3"	4 ⁵ / ₆₄	4 ⁸ / ₆₄	4 ⁵ / ₆₄	4.029					
				4 ⁶ / ₆₄	4.041					
				4 ⁷ / ₆₄	4.053					
				4 ⁸ / ₆₄	4.066					
CS300-16xx CF300-16xx	3"	4 ⁹ / ₆₄	4 ¹² / ₆₄	4 ⁹ / ₆₄	4.078					
				4 ¹⁰ / ₆₄	4.090					
				4 ¹¹ / ₆₄	4.103					
				4 ¹² / ₆₄	4.115					

Technical & Safety Information

CRIMPED RECOMMENDATION GUIDE

CAM & GROOVE COUPLER PART NO	CAM & GROOVE ADAPTER PART NO	KING COMBINATION NIPPLE PART NO	SLEEVE & FERRULE PART NO	HOSE ID	HOSE RANGE		HOSE OD	CRIMP DIAMETER (± 0.005)
					FROM	TO		
400-C-AL 400-C-BR 400-C-SS RC400EZCR G400-C-ALCR G400-C-BRCR G400-C-SSCR	400-E-AL 400-E-BR 400-E-SS G400-E-ALCR G400-E-BRCR G4400-E-SSCR	ST40CS RST40CS STV40CS RSTV40CS STB40CS RSTB40CS	CS400-1xx CF400-1xx	4"	4 ¹³ / ₆₄	4 ¹⁶ / ₆₄	4 ¹³ / ₆₄ 4 ¹⁴ / ₆₄ 4 ¹⁵ / ₆₄ 4 ¹⁶ / ₆₄	4.333 4.345 4.357 4.370
			CS400-2xx CF400-2xx	4"	4 ¹⁷ / ₆₄	4 ²⁰ / ₆₄	4 ¹⁷ / ₆₄ 4 ¹⁸ / ₆₄ 4 ¹⁹ / ₆₄ 4 ²⁰ / ₆₄	4.384 4.396 4.409 4.421
			CS400-3xx CF400-3xx	4"	4 ²¹ / ₆₄	4 ²⁴ / ₆₄	4 ²¹ / ₆₄ 4 ²² / ₆₄ 4 ²³ / ₆₄ 4 ²⁴ / ₆₄	4.433 4.445 4.457 4.470
			CS400-4xx CF400-4xx	4"	4 ²⁵ / ₆₄	4 ²⁸ / ₆₄	4 ²⁵ / ₆₄ 4 ²⁶ / ₆₄ 4 ²⁷ / ₆₄ 4 ²⁸ / ₆₄	4.486 4.498 4.510 4.523
			CS400-5xx CF400-5xx	4"	4 ²⁹ / ₆₄	4 ³² / ₆₄	4 ²⁹ / ₆₄ 4 ³⁰ / ₆₄ 4 ³¹ / ₆₄ 4 ³² / ₆₄	4.535 4.547 4.560 4.572
			CS400-6xx CF400-6xx	4"	4 ³³ / ₆₄	4 ³⁶ / ₆₄	4 ³³ / ₆₄ 4 ³⁴ / ₆₄ 4 ³⁵ / ₆₄ 4 ³⁶ / ₆₄	4.584 4.597 4.609 4.621
			CS400-7xx CF400-7xx	4"	4 ³⁷ / ₆₄	4 ⁴⁰ / ₆₄	4 ³⁷ / ₆₄ 4 ³⁸ / ₆₄ 4 ³⁹ / ₆₄ 4 ⁴⁰ / ₆₄	4.634 4.646 4.658 4.671
			CS400-8xx CF400-8xx	4"	4 ⁴¹ / ₆₄	4 ⁴⁴ / ₆₄	4 ⁴¹ / ₆₄ 4 ⁴² / ₆₄ 4 ⁴³ / ₆₄ 4 ⁴⁴ / ₆₄	4.683 4.695 4.708 4.720
			CS400-9xx CF400-9xx	4"	4 ⁴⁵ / ₆₄	4 ⁴⁸ / ₆₄	4 ⁴⁵ / ₆₄ 4 ⁴⁶ / ₆₄ 4 ⁴⁷ / ₆₄ 4 ⁴⁸ / ₆₄	4.732 4.745 4.757 4.770
			CS400-10xx CF400-10xx	4"	4 ⁴⁹ / ₆₄	4 ⁵² / ₆₄	4 ⁴⁹ / ₆₄ 4 ⁵⁰ / ₆₄ 4 ⁵¹ / ₆₄ 4 ⁵² / ₆₄	4.782 4.794 4.807 4.819
			CS400-11xx CF400-11xx	4"	4 ⁵³ / ₆₄	4 ⁵⁶ / ₆₄	4 ⁵³ / ₆₄ 4 ⁵⁴ / ₆₄ 4 ⁵⁵ / ₆₄ 4 ⁵⁶ / ₆₄	4.831 4.844 4.856 4.868
			CS400-12xx CF400-12xx	4"	4 ⁵⁷ / ₆₄	4 ⁶⁰ / ₆₄	4 ⁵⁷ / ₆₄ 4 ⁵⁸ / ₆₄ 4 ⁵⁹ / ₆₄ 4 ⁶⁰ / ₆₄	4.881 4.893 4.905 4.918
			CS400-13xx CF400-13xx	4"	4 ⁶¹ / ₆₄	5	4 ⁶¹ / ₆₄ 4 ⁶² / ₆₄ 4 ⁶³ / ₆₄ 5	4.930 4.942 4.955 4.967
			CS400-14xx CF400-14xx	4"	5 ¹ / ₆₄	5 ⁴ / ₆₄	5 ¹ / ₆₄ 5 ² / ₆₄ 5 ³ / ₆₄ 5 ⁴ / ₆₄	4.979 4.992 5.004 5.016
			CS400-15xx CF400-15xx	4"	5 ⁵ / ₆₄	5 ⁸ / ₆₄	5 ⁵ / ₆₄ 5 ⁶ / ₆₄ 5 ⁷ / ₆₄ 5 ⁸ / ₆₄	5.029 5.041 5.053 5.066
			CS400-16xx CF400-16xx	4"	5 ⁹ / ₆₄	5 ¹² / ₆₄	5 ⁹ / ₆₄ 5 ¹⁰ / ₆₄ 5 ¹¹ / ₆₄ 5 ¹² / ₆₄	5.078 5.090 5.103 5.115

N

CRIMPED RECOMMENDATION GUIDE

CAM & GROOVE COUPLER PART NO	CAM & GROOVE ADAPTER PART NO	KING COMBINATION NIPPLE PART NO	SLEEVE & FERRULE PART NO	HOSE ID	HOSE RANGE		HOSE OD	CRIMP DIAMETER (± 0.005)
					FROM	TO		
600-C-AL 600-C-BR 600-C-SS RC600EZCR G600-C-ALCR G600-C-BRCR G600-C-SSCR	600-E-AL 600-E-BR 600-E-SS G600-E-ALCR G600-E-BRCR G600-E-SSCR	ST60CS RST60CS STV60CS RSTV60CS STB60CS RSTB60CS	CS600-1xx CF600-1xx	6"	6 ²¹ /64	6 ²⁸ /64	6 ²¹ /64 6 ²² /64 6 ²³ /64 6 ²⁴ /64 6 ²⁵ /64 6 ²⁶ /64 6 ²⁷ /64 6 ²⁸ /64	6.504 6.516 6.528 6.541 6.553 6.565 6.577 6.589
			CS600-2xx CF600-2xx	6"	6 ²⁹ /64	6 ³⁶ /64	6 ²⁹ /64 6 ³⁰ /64 6 ³¹ /64 6 ³² /64 6 ³³ /64 6 ³⁴ /64 6 ³⁵ /64 6 ³⁶ /64	6.606 6.618 6.631 6.643 6.655 6.668 6.680 6.692
			CS600-3xx CF600-3xx	6"	6 ³⁷ /64	6 ⁴⁴ /64	6 ³⁷ /64 6 ³⁸ /64 6 ³⁹ /64 6 ⁴⁰ /64 6 ⁴¹ /64 6 ⁴² /64 6 ⁴³ /64 6 ⁴⁴ /64	6.705 6.717 6.729 6.742 6.754 6.766 6.779 6.791
			CS600-4xx CF600-4xx	6"	6 ⁴⁵ /64	6 ⁵² /64	6 ⁴⁵ /64 6 ⁴⁶ /64 6 ⁴⁷ /64 6 ⁴⁸ /64 6 ⁴⁹ /64 6 ⁵⁰ /64 6 ⁵¹ /64 6 ⁵² /64	6.803 6.816 6.828 6.841 6.853 6.853 6.878 6.890
			CS600-5xx CF600-5xx	6"	6 ⁵³ /64	6 ⁶⁰ /64	6 ⁵³ /64 6 ⁵⁴ /64 6 ⁵⁵ /64 6 ⁵⁶ /64 6 ⁵⁷ /64 6 ⁵⁸ /64 6 ⁵⁹ /64 6 ⁶⁰ /64	6.902 6.915 6.927 6.939 6.952 6.964 6.976 6.989
			CS600-6xx CF600-6xx	6"	6 ⁶¹ /64	7 ⁴ /64	6 ⁶¹ /64 6 ⁶² /64 6 ⁶³ /64 7 7 ¹ /64 7 ² /64 7 ³ /64 7 ⁴ /64	7.001 7.013 7.026 7.038 7.050 7.063 7.075 7.087
			CS600-7xx CF600-7xx	6"	7 ⁵ /64	7 ¹² /64	7 ⁵ /64 7 ⁶ /64 7 ⁷ /64 7 ⁸ /64 7 ⁹ /64 7 ¹⁰ /64 7 ¹¹ /64 7 ¹² /64	7.100 7.112 7.124 7.137 7.149 7.161 7.174 7.186
			CS600-8xx CF600-8xx	6"	7 ¹³ /64	7 ²⁰ /64	7 ¹³ /64 7 ¹⁴ /64 7 ¹⁵ /64 7 ¹⁶ /64 7 ¹⁷ /64 7 ¹⁸ /64 7 ¹⁹ /64 7 ²⁰ /64	7.198 7.211 7.223 7.236 7.248 7.260 7.273 7.285
			CS600-9xx CF600-9xx	6"	7 ²¹ /64	7 ²⁸ /64	7 ²¹ /64 7 ²² /64 7 ²³ /64 7 ²⁴ /64 7 ²⁵ /64 7 ²⁶ /64 7 ²⁷ /64 7 ²⁸ /64	7.297 7.310 7.322 7.334 7.347 7.359 7.371 7.384

Ball Valve



- Can be used for on and off service or throttling
- When positive shut-off is necessary
- Where a low valve profile is necessary
- Only 90° rotation from open to fully closed (quick opening)
- Handle position is a quick indication of whether valve is open or closed.
- Full port ball valves do not resist flow

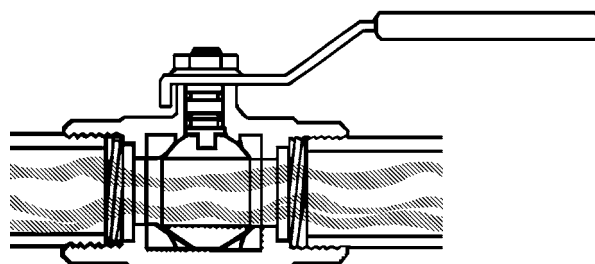

Butterfly Valve

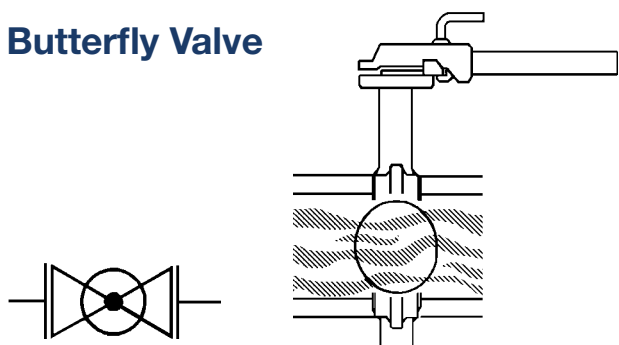

- Where positive shut-off is necessary
- Primarily for fully open or fully closed applications
- May be used for throttling
- Only 90° rotation from open to fully closed
- Lightweight
- Easy to install
- Less costly than an iron body gate valve

Gate Valve

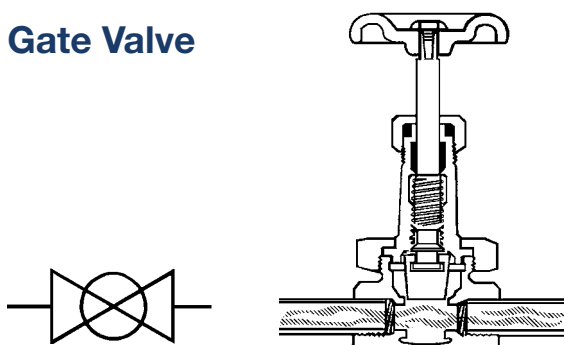

- For fully open or fully closed service - not for throttling
- For minimum line pressure drop
- For minimum fluid entrapment in the line
- For relatively infrequent operation

Check Valve

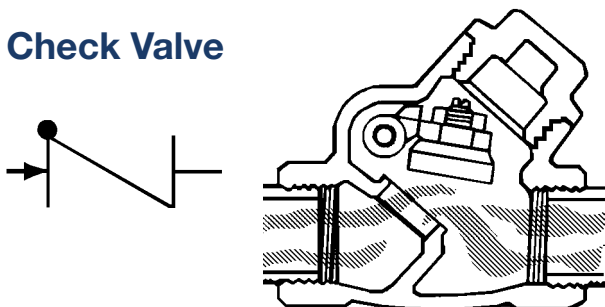

- To control the direction of flow and for quick, automatic reactions to flow change. Swing check valves are used when a minimum resistance to flow is required.
- Swing check valves are recommended for use in conjunction with gate valves. They should not be used in a rapid recycling system such as reciprocating pumps or air compressor service where they could cause chatter and damaging vibration.

Globe Valve

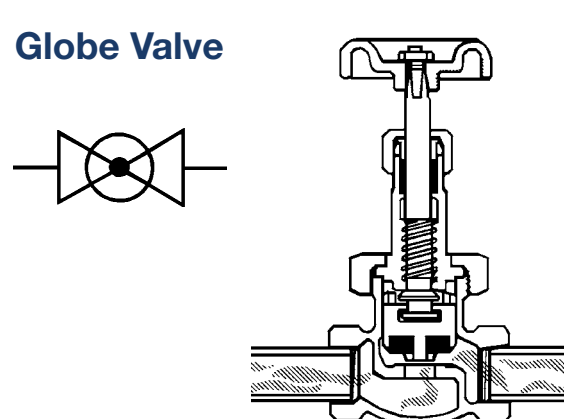

- For regulation (throttling) of flow
- For frequent operation; short stem travel reduces operator's time
- Where some line resistance is acceptable

A Guideline for Compound Selection for Use with Various Fluids and Chemicals

Note: The information contained in these tables was derived from several sources and is to be used as a general guide only. Compounds suitable for any specification application rests solely by the end user. Dixon Sanitary assumes no responsibility. All effect ratings assume static conditions at ambient temperatures.

A) satisfactory **B)** fair **C)** severe effect; except for some static applications **D)** unsatisfactory **E)** insufficient information

FLUID	Buna	EPDM	Viton®	PTFE	Silicone	FLUID	Buna	EPDM	Viton®	PTFE	Silicone
Acetaldehyde	D	A	D	A	B	Butyl Alcohol	A	B	A	A	B
Acetamide	A	A	B	A	B	Butyl Amine	C	B	D	E	D
Acetic Acid, 30%	B	A	B	A	A	Butyl Benzoate	D	B	A	E	E
Acetone	D	A	D	A	C	Butyl Carbitol	D	A	A	A	D
Acetophenone	D	A	D	A	D	Butyl Cellosolve	D	A	D	A	E
Acetyl Chloride	D	D	A	A	C	Butyl Oleate	D	B	A	E	E
Acetylene	A	A	A	A	B	Butyl Stearate	B	C	A	E	E
Acrylonitrile	D	D	C	A	D	Butylene	B	D	A	E	D
Adipic Acid	A	A	E	E	E	Butyraldehyde	D	B	D	E	D
Ammonia Gas (cold)	A	A	D	A	A	Carbolic Acid (Phenol)	D	B	A	A	D
Ammonium Chloride (aq)	A	A	A	A	E	Carbon Bisulfide	C	D	A	E	D
Ammonium Hydroxide (conc.)	D	A	B	A	A	Carbon Dioxide	A	B	A	E	B
Ammonium Nitrate (aq)	A	A	E	A	E	Carbonic Acid	B	A	A	E	A
Ammonium Nitrite (aq)	A	A	E	E	B	Carbon Monoxide	A	A	A	A	A
Ammonium Phosphate (aq)	A	A	E	A	A	Carbon Tetrachloride	C	D	A	A	D
Ammonium Sulfate (aq)	A	A	D	A	E	Castor Oil	A	B	A	A	A
Amyl Acetate (Banana Oil)	D	A	D	A	D	Cellosolve Acetate	D	B	D	A	D
Amyl Alcohol	B	A	B	A	D	China Wood Oil (Tung Oil)	A	C	A	A	D
Amyl Borate	A	D	A	A	E	Chlorine (wet)	D	C	A	A	D
Arsenic Acid	A	A	A	E	A	Chlorine Dioxide	D	C	A	A	E
Arsenic Trichloride (aq)	A	C	E	E	E	Chloroacetic Acid	D	A	D	A	E
Barium Chloride (aq)	A	A	A	A	A	Chloroacetone	D	A	D	E	D
Barium Hydroxide (aq)	A	A	A	A	A	Chlorobenzene	D	D	A	E	D
Barium Sulfate (aq)	A	A	A	A	A	Chlorobromomethane	D	B	A	E	D
Barium Sulfide (aq)	A	A	A	A	A	Chloroform	D	D	A	A	D
Benzaldehyde	D	A	D	A	B	Chlorotoluene	D	D	A	E	D
Benzene	D	D	A	A	D	Chrome Plating Solutions	D	C	A	A	C
Benzoic Acid	C	C	A	A	C	Chromic Acid	D	B	A	A	B
Benzoyl Chloride	D	D	A	A	E	Cod Liver Oil	A	A	A	A	B
Benzyl Alcohol	D	A	A	A	B	Copper Acetate (aq)	B	A	D	E	D
Benzyl Chloride	D	D	A	A	D	Copper Chloride (aq)	A	A	A	A	A
Boric Acid	A	A	A	A	A	Copper Cyanide (aq)	A	A	A	A	A
Brine	A	A	A	A	A	Copper Sulfate (aq)	A	A	A	A	A
Bromine, Anhydrous	D	D	A	E	D	Creosote (coal tar)	A	D	A	A	D
Bromine Water	D	B	A	E	D	Cresylic Acid	D	D	A	E	D
Butadiene	D	C	A	A	D	Cyclohexane	A	D	A	A	D
Butane	A	D	A	A	D	Cyclohexanol	C	C	A	E	D
Butyl Acetate	D	C	D	E	D	Cyclohexanone	D	B	D	E	D
Butyl Acetyl Ricinoleate	C	A	A	E	E	Denatured Alcohol	A	A	A	A	A

Technical & Safety Information

FLUID	Buna	EPDM	Viton®	PTFE	Silicone	FLUID	Buna	EPDM	Viton®	PTFE	Silicone
Detergent Solutions	A	A	A	A	A	Ethyl Ether	C	C	D	A	D
Diacetone Alcohol	D	A	D	A	B	Ethyl Pentachlorobenzene	D	D	A	A	D
Dibenzyl Ether	D	B	D	A	E	Ethylene	A	B	A	A	E
Dibenzyl Sebecate	D	B	B	E	C	Ethylene Chloride	D	C	B	E	D
Dibromoethyl Benzene (Alkazene)	D	D	B	E	D	Ethylene Diamine	A	A	D	E	A
Dibutyl Amine	D	C	D	E	C	Ethylene Dichloride	D	C	A	A	D
Dibutyl Ether	D	C	C	E	D	Ethylene Glycol	A	A	A	A	A
Dibutyl Phthalate	D	B	C	A	B	Fluoroboric Acid	A	A	E	E	E
Dibutyl Sebecate	D	B	B	E	B	Freon 11	B	D	A	A	D
O-Dichlorobenzene	D	D	A	E	D	Freon 12	A	B	B	A	D
Dichloro-Isopropyl Ether	D	C	C	E	D	Freon 22	D	A	D	A	D
Diethylamine	B	B	D	A	B	Fumaric Acid	A	B	A	E	B
Diethyl Benzene	D	D	A	E	D	Galic Acid	B	B	A	A	E
Diethyl Ether	D	D	D	E	D	Gasoline	B	D	A	A	D
Diethylene Glycol	A	A	A	E	B	Glucose	A	A	A	A	A
Diethyl Sebecate	B	B	B	E	B	Glycerin	A	A	A	A	A
Diisobutylene	B	D	A	E	D	Hexane	A	D	A	A	D
Diisopropyl Benzene	D	D	A	E	E	Hexyl Alcohol	A	C	A	A	B
Diisopropyl Ketone	D	A	D	E	D	Hydrazine	B	A	D	A	C
Diisopropylidene Acetone	D	C	D	E	D	Hydrobromic Acid	D	A	A	E	D
Dimethyl Aniline (Xylidine)	C	B	D	E	D	Hydrocyanic Acid	B	A	A	A	C
Dimethyl Ether (Methyl Ether)	A	D	A	E	A	Hydrofluoric Acid (conc.) cold	D	C	A	A	D
Dimethyl Formamide	B	B	D	E	B	Hydrofluosilicic Acid	B	B	A	E	D
Dimethyl Phthalate	D	B	B	E	E	Hydrogen Gas	A	A	A	A	C
Dinitrotoluene	D	D	D	E	D	Hydrogen Peroxide (90%)	D	B	B	E	B
Diocetyl Phthalate	C	B	B	E	C	Hydrogen Sulfide (wet) cold	D	A	D	E	C
Diocetyl Sebecate	D	B	B	E	C	Hydroquinone	C	B	B	A	E
Dioxane	D	B	D	E	D	Iodoform	E	D	E	E	E
Dioxolane	D	B	D	E	D	Isobutyl Alcohol	B	A	A	A	A
Dipentene	A	D	A	E	D	Isooctane	A	D	A	E	D
Diphenyl (Phenylbenzene)	D	D	A	E	D	Isopropyl Acetate	D	B	D	A	D
Diphenyl Oxides	D	D	A	E	C	Isopropyl Alcohol	B	A	A	A	A
Dowtherm Oil	D	D	A	A	C	Isopropyl Chloride	D	D	A	A	D
Ethane	A	D	A	A	D	Isopropyl Ether	B	D	D	A	D
Ethanolamine	B	B	D	E	B	Kerosene	A	D	A	A	D
Ethyl Acetate	D	B	D	E	B	Lacquers	D	D	D	A	D
Ethyl Acetoacetate	D	B	D	E	B	Lactic Acid (cold)	A	A	A	A	A
Ethyl Acrylate	D	B	D	E	B	Lead Acetate (aq)	B	A	D	E	D
Ethyl Alcohol	A	A	C	A	A	Lead Nitrite (aq)	A	A	E	E	B
Ethyl Benzene	D	D	A	A	D	Lime Bleach	A	A	A	E	B
Ethyl Benzoate	D	A	A	A	D	Linoleic Acid	B	D	B	A	B
Ethyl Cellosolve	D	B	D	E	D	Maleic Acid	D	B	A	A	E
Ethyl Cellulose	B	B	D	A	C	Malic Acid	A	B	A	E	B
Ethyl Chloride	A	C	A	A	D	Methane	A	D	B	A	D
Ethyl Chlorocarbonate	D	B	A	A	D	Methyl Acetate	D	A	D	A	D
Ethyl Chloroformate	D	B	D	E	D	Methyl Acrylate	D	B	D	A	D

INFORMATION COMPILED FROM NEWMAN GASKETS WEBSITE, WWW.NEWMANGASKET.COM

Technical & Safety Information

FLUID	Buna	EPDM	Viton®	PTFE	Silicone	FLUID	Buna	EPDM	Viton®	PTFE	Silicone
Methylacrylic Acid	D	B	D	E	D	i-Propyl Acetate	D	B	D	E	D
Methyl Alcohol	A	A	D	A	A	Propyl Nitrate	D	B	D	E	D
Methyl Bromide	B	D	A	A	E	Propylene	D	D	A	A	D
Methyl Butyl Ketone	D	A	D	A	C	Pyridine	D	B	D	E	D
Methyl Cellosolve	C	B	D	A	D	Salicylic Acid	B	A	A	E	E
Methyl Chloride	D	C	B	A	D	Silicone Oils	A	A	A	A	C
Methyl Cyclopentane	D	D	B	E	D	Soap Solutions	A	A	A	A	A
Methylene Chloride	D	C	B	E	D	Sodium Acetate (aq)	B	A	D	E	D
Methyl Ether	A	D	A	A	A	Sodium Bicarbonate (aq) (baking soda)	A	A	A	A	A
Methyl Ethyl Ketone	D	A	D	A	D	Sodium Borate (aq)	A	A	A	A	A
Methyl Isobutyl Ketone	D	B	D	A	D	Sodium Chloride (aq)	A	A	A	A	A
Methyl Methacrylate	D	C	D	A	D	Sodium Hydroxide (aq)	B	A	B	A	B
Milk	A	A	A	A	A	Sodium Nitrate (aq)	B	A	E	E	D
Mineral Oil	A	C	A	C	B	Sodium Peroxide (aq)	B	A	A	E	D
Monoethanol Amine	D	A	D	E	B	Soybean Oil	A	C	A	A	A
Monomethyl Ether	A	D	A	E	A	Steam, under 300°F	D	A	D	A	C
Monovinyl Acetylene	A	A	A	A	B	Stearic Acid	B	B	E	A	B
Mustard Gas	E	A	E	E	A	Stoddard Solvent	A	D	A	A	D
Naphthalenic Acid	B	D	A	A	D	Sulfur Chloride (aq)	C	D	A	B	C
Natural Gas	A	D	A	A	A	Sulfuric Acid (dilute)	C	B	A	E	D
Nickel Acetate (aq)	B	A	D	E	D	Sulfurous Acid	B	B	A	A	D
Nickel Chloride (aq)	A	A	A	A	A	Tannic Acid	A	A	A	A	B
Nickel Sulfate (aq)	A	A	A	A	A	Tartaric Acid	A	B	A	A	A
Nitric Acid (dilute)	D	B	A	A	B	Tetrachloroethylene	D	D	A	A	D
Nitrobenzene (Ligroin)	A	D	A	A	D	Toluene	D	D	A	A	D
Nitroethane	D	B	D	A	D	Triethanol Amine	B	A	D	A	E
Nitrogen Tetroxide	D	C	D	A	D	Trioctyl Phosphate	D	A	B	E	C
Octachlorotoluene	D	D	A	E	D	Tung Oil (China Wood Oil)	A	C	A	A	D
Octadecane	A	D	A	E	D	Turpentine	A	D	A	A	D
N-Octane	B	D	A	A	D	Vegetable Oils	A	C	A	A	B
Octyl Alcohol	B	C	A	A	B	Vinegar	B	A	A	A	A
Oleic Acid	C	D	B	A	D	Whiskey, Wines	A	A	A	A	A
Oxalic Acid	B	A	A	E	B	White Pine Oil	B	D	A	E	D
Oxygen - Cold	B	A	A	A	A	Zinc Chloride (aq)	A	A	A	A	A
Ozone	D	A	A	E	A						
Palmitic Acid	A	B	A	E	D						
Perchloric Acid	D	B	A	E	D						
Phenyl Ethyl Ether	D	D	D	E	D						
Phosphoric Acid - 20%	B	A	A	E	B						
Phosphorus Trichloride	D	A	A	A	E						
Piperidine	D	A	D	E	D						
Polyvinyl Acetate Emulsion	E	A	E	E	E						
Potassium Acetate (aq)	B	A	D	E	D						
Potassium Chloride (aq)	A	A	A	A	A						
Potassium Cyanide (aq)	A	A	A	A	A						
Potassium Nitrate (aq)	A	A	A	A	A						

INFORMATION COMPILED FROM NEWMAN GASKETS WEBSITE, WWW.NEWMANGASKET.COM



Trademarks

Pyrex® is a registered trademark of Corning Glass.

PTFE is a registered trademark of E.I. duPont Nemours and Company.

Tri-Clamp® is a registered trademark of Tri-Clover, Inc.

Viton® is a registered trademark of DuPont Dow Elastomers.

Water Data and Formulas (no losses included)

Water Level (inches)	Gallons per Minute Discharge for a Given Nominal Pipe Diameter (inches)				
	5	6	8	10	12
5	163	---	---	---	---
6	195	285	---	---	---
7	228	334	580	---	---
8	260	380	665	---	---
9	293	430	750	---	1660
10	326	476	830	---	1850
11	360	525	915	---	2020
12	390	570	---	---	2220
13	425	620	---	---	2400
14	456	670	---	---	2590
15	490	710	---	---	2780
16	520	760	---	---	2960
17	550	810	---	---	3140
18	590	860	---	---	3330
19	620	910	---	---	3500
20	650	950	---	---	3700
21	685	---	---	---	3890
22	720	---	---	---	4060
23	750	---	---	---	4250
24	---	---	---	---	4440

1 gallon water = 231 cubic inches = 8.333 pounds

1 pound of water = 27.7 cubic inches

1 cubic foot water = 7.5 gallons = 62.5 pounds (salt water weighs approximately 64.3 pounds per cubic foot)

Pounds per square inch at bottom of a column of water = height of column in feet x .434

1 miner's inch = 9 to 12 gallons per minute

Horsepower to Raise Water

If pumping liquid other than water, multiply the gallons per minute below by the liquids specific gravity

$$\text{Horsepower} = \frac{\text{gallons per minute} \times \text{total head in feet}}{3960}$$

Gallons Per Minute through a Pipe

GPM = .0408 x pipe diameter (inches²) x water velocity (feet/minute)

Weight of Water in a Pipe

Pounds water = pipe length (feet) x pipe diameter (inches²) x .34

Metal Chemistry

Element	C	Mn	P	S	Si	Cr	Ni	Mo
304 ¹	0.08	2.00	0.045	0.030	1.00	18.0-20.0	8.0-10.0	
316L ¹	0.03	2.00	0.045	0.030	1.00	16.0-18.0	10.0-14.0	2.0-3.0
316L BPE ²	0.03	2.00	0.045	0.05 - 0.17	1.00	16.0-18.0	10.0-14.0	2.0-3.0
CF-8 ³	0.08	1.50	0.04	0.04	2.00	18.0-21.0	8.0-11.0	
CF-8M ³	0.08	1.50	0.04	0.04	2.00	18.0-21.0	9.0-12.0	2.0-3.0

¹ AISI specifications for wrought material

² ASME BPE 2002

³ ASTM A743

- Percentages are maximums unless a range is specified

Finish Information

Finish Specifications

Process	RA micro inch	RA micron	ISO designation
150 grit	30 - 35	0.75 - 0.875	N6
150 grit + Electropolish	12 - 20	0.3 - 0.5	
180 grit	20 - 25	0.5 - 0.625	
180 grit + Electropolish	10 - 16	0.25 - 0.4	
240 grit	15 - 20	0.375 - 0.5	N5
240 grit + Electropolish	8 - 12	0.2 - 0.3	
320 grit	8 - 12	0.2 - 0.3	N4
320 grit + Electropolish	6 - 12	0.15 - 0.3	

- Additional improvements to the surface finish require buffing and further electropolishing. The effect of electro polishing is to improve the existing surface by approximately 50%.
- Microinch = 2.54×10^{-8} m
Micron = 1.0×10^{-6} m

Finish Designations for Tubing and Fittings

Finish Number	Finish Conditions
1	Mill Finish (bright annealed, pickled, sand blast or tumbled)
3	Polished 180 grit inside diameter (ID) only
5	Polished 150 grit outside diameter (OD) only
7	Polished 180 grit outside/inside diameter (OD/ID)
3A	Polished 150 grit outside (OD), 180 grit inside diameter (ID)

- 180 grit = 25Ra microinch = 0.5Ra micron (minimum)

3-A marking

Note: Bradford™ tubing meets 3A Sanitary Standards for Polished Metal Tubing for Milk and Milk products 33-01.

Valve Seat Materials

Butterfly Valve Elastomer Information

Property	EPDM	Silicone	Viton® (FKM)
tensile strength	good-excellent	good	good-excellent
electrical properties	excellent	excellent	good
weather resistance	excellent	excellent	excellent
heat resistance *	excellent (275° F)	excellent (450°F)	excellent (400° F)
cold resistance *	Good-excellent (-55°F)	excellent (-80°F)	good (-20° F)
steam resistance	good	good	excellent
tear resistance	good	good	good
abrasion resistance	good-excellent	good-excellent	good
acid resistance	good-excellent	good	good
petroleum oil	poor	good	excellent
flame resistance	poor	poor	good
vegetable oil	good (most)	good (intermittent)	excellent

* Temperature information is for elastomer only, not in valve application. EPDM or Viton® are recommended for ozone treated water.

Seat Materials for Ball Valves

Code	Designation	Material	Applications
V	virgin PTFE	virgin polytetrafluoroethylene	100% PTFE. Our standard seat material. Ideal for most sanitary services. Specified for applications requiring a low co-efficient of friction. 3A and FDA approved.
G	RTFE	15% glass reinforced tetrafluoroethylene	15% glass filled = 85% PTFE. Slightly higher temperature and pressure rating than PTFE. Specified for applications requiring higher cycle life than PTFE. 3A and FDA approved.
C	25% carbon PTFE	25% carbon reinforced tetrafluoroethylene	25% carbon + 75% PTFE. Specified for higher temperature pressure applications. Ideal for steam and thermal fluid applications. Higher cycle life than RTFE.
S	SS reinforced PTFE	50% stainless steel filled tetrafluoroethylene	50% SS = 50% PTFE. Specified for higher temperature pressure applications in a sanitary process. 3A and FDA approved.
U	UHMW	ultra high molecular weight polyethylene	Specified for its low modulus of abrasion and minimal property degradation when exposed to moderate levels of radiation. Ideal for applications where fluorocarbons are not acceptable. 3A and FDA approved.

All fittings Comply with ASME BPE-2009 - Table DT-5-1 Final Tolerances for Mechanically Polished Fittings and Process Components (inches)

Nominal Size	O.D.	Wall Thickness	Squareness Face to Tangent	Off Angle	Tolerance on End-to-End & Center-to-End	Off Plane
1/2"	±0.005	+0.005/-0.008	0.005	0.014	0.050	0.030
3/4"	±0.005	+0.005/-0.008	0.005	0.018	0.050	0.030
1"	±0.005	+0.005/-0.008	0.008	0.025	0.050	0.030
1 1/2"	±0.008	+0.005/-0.008	0.008	0.034	0.050	0.050
2"	±0.008	+0.005/-0.008	0.008	0.043	0.050	0.050
2 1/2"	±0.010	+0.005/-0.008	0.010	0.054	0.050	0.050
3"	±0.010	+0.005/-0.008	0.016	0.068	0.050	0.050
4"	±0.015	+0.008/-0.010	0.016	0.086	0.050	0.060

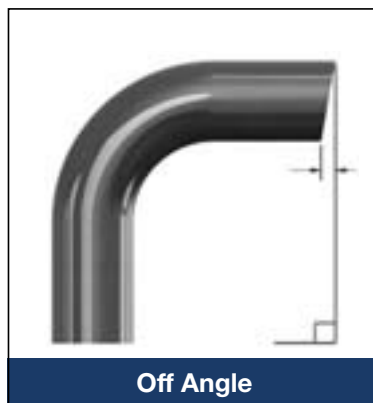
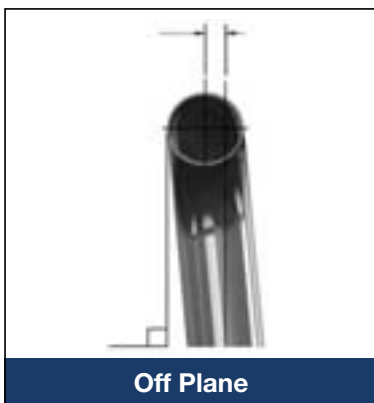

Technical & Safety Information

Weld End chemical analysis (%) per ASME BPE 2009 Table DT-3

Element	C	Mn	P	S	Si	Cr	Ni	Mo
minimum	---	---	---	0.005	---	16.00	10.00	2.00
maximum	0.030	2.00	0.045	0.017	1.00	18.00	15.00	3.00

BPE Surface Finish Requirements

Surface designation	Mechanically Polished ID and OD		Bradford™ High Purity code
	R _a Maximum		
	ID μ-in.	OD μ-in.	
SF0	no finish requirement	no finish requirement	
SF1	20	32	PL
SF2	25	32	
SF3	30	32	
Surface designation	Mechanically Polished OD and Electropolished ID		Bradford™ High Purity code
	R _a Maximum		
	ID μ-in.	OD μ-in.	
SF4	15	32	PM
SF5	20	32	
SF6	25	32	

Acceptance Criteria for Stainless Steel and Higher Alloy Mechanically Polished Product Contact Surface Finishes

Anomaly or Indication	Acceptance Criteria
Pits	If diameter <0.020 in. and bottom is shiny [Notes (2) and (4)]. Pits <0.003 in. Diameter are irrelevant and acceptable.
Cluster of pits	No more than 4 pits per each 1/2 in. x 1/2 in. inspection window. The cumulative total of all relevant pits shall not exceed 0.040 in.
Dents	None accepted [Note (1)].
Finishing marks	If R _a max. is met.
Welds	As welded shall meet requirements of MJ-6. If welds are finished, then shall be smooth and blended.
Nicks	None accepted.
Scratches	For tubing, if cumulative length is <12.0 in. per 20 ft tube length or prorated and if depth is <0.003 in. For fittings, valves and other process components, if length is <0.25 in. cumulatively, depth <0.003 in. and R _a max. is met. For vessels, if length <0.50 in. at 0.003 depth and if <3 per inspection window [Note (3)].
Surface cracks	None accepted.
Surface inclusions	If R _a max. is met.
Surface residuals	None accepted, visual inspection
Surface roughness (R _a)	See Table SF-3 (request from Dixon Sanitary)
Weld slag	For tubing, up to 3 per 20 ft length or prorated, if <75% of the width of the weld bead. For fittings, valves, vessels and other process components, none accepted (as welded shall meet the requirements of MJ-6 and Table MJ-3).
Porosity	None open to the surface.

*Notes:

- (1) For Vessels, dents in the area covered by and resulting from welding dimple heat transfer jackets are acceptable.
- (2) Black bottom pit of any depth is not acceptable.
- (3) An inspection window is defined as an area 4 in. x 4 in.
- (4) Pits in super-austenitic and nickel alloys may exceed this value. Acceptance criteria for pit size shall be established by agreement between owner/user and manufacturer. All other pit criteria remain the same.

Packaging

Product markings per ASME BPE 2009 DT-14.1

- Bradford™
- Job number
- 316L
- Bradford™ part number
- Heat number(s)
- Surface finish code
- ASME BPE

Per the specification, the size of the fitting may limit the space available for markings. When that occurs, the markings starting at the bottom of the list are not applied. The Bradford™ part number will describe the part configuration and size.

MTR certifications are included inside the resealable bag with each fitting.

The MTRs are traceable through the Job Number found on each fitting. All fittings are capped to prevent damage and contamination.

For easy identification each finish will have a different color cap.

*Finish	Color Caps
PL/SF1	blue
PM/SF4	white

* See page 5 for Ra standards

Bradford™ High Purity

BioPharm Fittings

316L Stainless Steel Material Test Report

Job Number **AA158**

Bradford™ Part Number	Description	Size	Surface finish
T16W-200PL	BPE auto weld cap Table DT-30	2"	SF1

Chemical analysis (%) per ASME BPE 2009 Table DT-3

Item	Heat number	C	Mn	P	S	Si	Cr	Ni	Mo	
		0.030	2.00	0.045	0.017	1.00	18.00	10.00	2.00	min.
							18.00	15.00	3.00	max.
M	823310	0.014	1.40	0.034	0.012	0.44	18.30	10.10	2.07	
B	823707	0.014	1.49	0.033	0.010	0.38	18.20	10.10	2.08	

Mechanical Test Results

Item	Yield Strength (0.2%), MPa	Tensile Strength, MPa	Elongation, %	Hardness, HRB	Specification
	170 minimum	485 minimum	35 minimum	90 maximum	
M	378	624	46.1	88	ASTM A269
B	358	566	43.9	83	ASTM A269

Product of Thailand

We certify that the above is a true copy of the test results issued by the material supplier. This MTR conforms to EN12204 3.1. All fittings supplied by Dixon Sanitary conform to the requirements of the European Union Directive 2002/95/EC on the restriction of the use of certain hazardous substances in electrical and electronic equipment (RoHS).

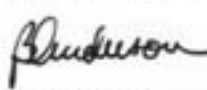

Bruce Anderson
Technical Director



The Right Connection™

Dixon Sanitary
N25 W23040 Paul Rd.
Pewaukee, WI 53072
USA
800-789-1718
bradfordfittings.com

Valve Actuation Questionnaire Checklist

Contact Name: _____ Company Name: _____
 Date _____ Phone # _____ Fax # _____ Email _____
 Project Name: _____

Butterfly Valves

System Media & Pressure _____
 System Temperature _____
 Quantity _____ Size _____

Seat Material:

Silicone EPDM Viton®

End Connections:

RJT DIN IDF SMS
 Clamp Buttweld 150 # flg NPT
 BSPT BSPP

Male/Female configuration if applicable: _____ x _____

Pneumatic Actuation

Operation:

double acting spring return (fail close)
 spring return (fail open)

Rotation:

90° 180°

System Pressure (PSI):

80 60 other

Type:

rack & pinion vertical canister
 horizontal canister

Material: aluminum nickel plated stainless steel

Positioner:

pneumatic (3-15 PSI) electro-pneumatic (4-20mA)

Gauges:

0-30 0-160 0-160 0-160
 full set

Feedback:

mechanical prox
 4-20 mA 4-20 mA & mech (2)

Limit Switches:

SPDT SPST DPDT mechanical
 proximity 2 position 3 position (no feedback)
 3 position (feedback) 4-20mA transmitter
 4-20mA transmitter & mech (2)

Visual Indicator:

flat pointer dome open/close dome 3-way L
 dome 3-way T dome 4-way L dome 4-way T

NEMA rating: 4/4x 7/9

Solenoid: 3 way 4 way single coil
 dual coil

Voltage: 12VDC 24VDC 24VAC
 110VAC 220VAC

NEMA rating: 4/4x 7/9

Ball Valves

System Media & Pressure _____
 System Temperature _____
 Quantity _____ Size _____

Type:

2 way 3 way T 3 way L 4 way
 double L

4 way T 4 way L flow conf.

Construction:

sanitary industrial

Body Material:

stainless steel brass

Seat Design:

PTFE UHMW 15% glass 25% carbon
 50% stainless

End Connections:

RJT DIN IDF SMS
 Clamp Buttweld 150 # flg NPT
 BSPT BSPP

Male/Female configuration if applicable: _____ x _____

Electric Actuation

Operation:

2 position spring return (fail close)
 spring return (fail open) modulating controller board

Board Signal:

1-5V 2-10V 4-20mA

Power Supply:

12VDC 24VDC 24VAC 110VAC
 220VAC 3 phase 440VAC 3 phase

NEMA rating: 4/4x 7/9

Manual Override:

Yes No

Accessories:

2 extra switches heater (standard)
 potentiometer current position transmitter
 torque switches local control unit
 battery backup

Please attach any additional specifications or information,
 _____ # of pages.

Regulations: OSHA & MSHA

OSHA

Standards - 29 CFR, 1910.242 (partial):

- (b) Compressed air used for cleaning - Compressed air shall not be used for cleaning purposes except where reduced to less than 30 psi and then only with effective chip guarding and personal protective equipment.

Standards - 29 CFR, 1915.131 (partial):

- (e) Before use, pneumatic tools shall be secured to the extension hose or whip by some positive means to prevent the tool from becoming accidentally disconnected from the whip.

Standards - 29 CFR, 1926.302 (partial):

- (b)(1) Pneumatic power tools shall be secured to the hose or whip by some positive means to prevent the tool from becoming accidentally disconnected.
- (b)(2) Safety clips or retainers shall be securely installed and maintained on pneumatic impact (percussion) tools to prevent attachments from being accidentally expelled.
- (b)(3) All pneumatically driven nailers, staplers and other similar equipment provided with automatic fastener feed, which operate at more than 100 psi pressure at the tool shall have a safety device on the muzzle to prevent the tool from ejecting fasteners, unless the muzzle is in contact with the work surface.
- (b)(4) Compressed air shall not be used for cleaning purposes except where reduced to 30 psi and then only with effective chip guarding and personal protective equipment which meets the requirements of Subpart E of this part. The 30 psi requirement does not apply for concrete form, mill scale and similar cleaning purposes.
- (b)(5) The manufacturer's safe operating pressure for hoses, pipes, valves, filters and other fittings shall not be exceeded.
- (b)(6) The use of hoses for hoisting or lowering tools shall not be permitted.
- (b)(7) All hoses exceeding 1/2" inside diameter shall have a safety device at the source of supply or branch line to reduce pressure in case of hose failure.

Standards - 29 CFR, 1926.306

- (a) "General requirements"
- (a)(1) "Application." This section applies to compressed air receivers, and other equipment used in providing and utilizing compressed air for performing operations such as cleaning, drilling, hoisting, and chipping. On the otherhand, however, this section does not deal with the special problems created by using compressed air to convey materials nor the problems created when men work in compressed air as in tunnels and caissons. This section is not intended to apply to compressed air machinery and equipment used on transportation vehicles such as steam railroad cars, electric railway cars, and automotive equipment.
- (a)(2) "New and existing equipment."
- (a)(2)(i) All new air receivers installed after the effective date of these regulations shall be constructed in accordance with the 1968 edition of the A.S.M.E. Boiler and Pressure Vessel Code Section VIII.
- (a)(2)(ii) All safety valves used shall be constructed, installed and maintained in accordance with the A.S.M.E. Boiler and Pressure Vessel Code, Section VIII Edition 1968.
- (b) 1926.306(b) "Installation and equipment requirements"
- (b)(1) "Installation." Air receivers shall be so installed that all drains, handholes, and manholes therein are easily accessible. Under no circumstances shall an air receiver be buried underground or located in an inaccessible place.
- (b)(2) "Drains and traps." A drain pipe and valve shall be installed at the lowest point of every air receiver to provide for the removal of accumulated oil and water. Adequate automatic traps may be installed in addition to drain valves. The drain valve on the air receiver shall be opened and the receiver completely drained frequently and at such intervals as to prevent the accumulation of excessive amounts of liquid in the receiver.
- (b)(3) "Gauges and valves."
- (b)(3)(i) Every air receiver shall be equipped with an indicating pressure gauge (so located as to be readily visible) and with one or more spring-loaded safety valves. The total relieving capacity of such safety valves shall be such as to prevent pressure in the receiver from exceeding the maximum allowable working pressure of the receiver by more than 10 percent.
- (b)(3)(ii) No valve of any type shall be placed between the air receiver and its safety valve or valves.

Standards - 29 CFR, 1926.603 (partial):

- (a)(9) Steam hose leading to a steam hammer or jet pipe shall be securely attached to the hammer with an adequate length of at least 1/4-inch diameter chain or cable to prevent whipping in the event the joint at the hammer is broken. Air hammer hoses shall be provided with the same protection as required for steam lines.
- (a)(10) Safety chains, or equivalent means, shall be provided for each hose connection to prevent the line from thrashing around in case the coupling becomes disconnected.

Regulations: OSHA & MSHA (cont'd)

MSHA (Mine Safety and Health Administration)

Standards - 30 CFR Sections 56.13021 and 57.13021

Except where automatic shut-off valves are used, safety chains or other suitable locking devices shall be used at connections to machines of high-pressure hose line of $\frac{3}{4}$ " inside diameter or larger, and between high-pressure hose lines of $\frac{3}{4}$ " inside diameter or larger, where a connection failure would create a hazard.

Standards - 30 CFR Section 75.1730

(e) Safety chains, suitable locking devices, or automatic cut-off valves shall be used at connections to machines of high-pressure hose lines of $\frac{3}{4}$ " inside diameter or larger, and between high-pressure hose lines of $\frac{3}{4}$ " inside diameter or larger, where a connection failure would create a hazard. For purposes of this paragraph, high-pressure means pressure of 100 psi or more.

Standards - 30 CFR Section 77.412

(d) Safety chains or suitable locking devices shall be used at connections to machines of high-pressure hose line of 1-inch inside diameter or larger, and between high-pressure hose line of 1-inch inside diameter or larger, where a connection failure would create a hazard.

Fluid Compatibility Guide - Dixon Quick Couplings

WARNING!

The following chart is intended only as a guide in selecting various elastomers and metals for use with fluids to be conveyed through Dixon Quick Disconnect Couplings. This list does not guarantee suitability for a particular application. Final selection is dependent upon operating pressure, fluid and ambient temperature, concentration of media, duration of exposure, environmental conditions, and frequency of connect and disconnect.

Material	Prefix Code	Trade Name	Availability*	Range °C	Range °F
Buna-N	Standard	Nitrile	Stock	-40°C to +121°C	-40°F to +250°F
Buna-N (MIL-H-5606 Fluids)	M-	Nitrile	3-5 Days	-54°C to +135°C	-65°F to +275°F
Buna-N (Hydrocarbon Fuels)	JF-	Nitrile	3-5 Days	-54°C to +71°C	-65°F to +160°F
Fluorocarbon Rubber (FKM)	F-	Viton	3-5 Days	-29°C to +204°C	-20°F to +400°F
Ethyl Propylene Diene Monomer	P-	EPDM	5-7 Days	-54°C to +149°C	-65°F to +300°F
Neoprene	E-	Neoprene	7-10 Days	-43°C to +149°C	-45°F to +300°F
Silicone	S-	Silicone	7-10 Days	-73°C to +177°C	-100°F to +350°F
Fluorosilicone (FVMQ)	FS-	Silastic	7-10 Days	-60°C to +180°C	-76°F to +376°F
Urethane	U-	Urethane	7-10 Days	-40°C to +82°C	-40°F to +180°F
Polyurethane	UP-	Polyurethane	7-10 Days	-54°C to +100°C	-65°F to 212°F
PTFE Encapsulated Silicone	TS-	TES	7-10 Days	-73°C to +204°C	-100°F to +400°F
Perfluoroelastomer (Compound 1)	K4-	Kalrez 4079	5-7 Days	-20°C to +316°C	-4°F to +600°F
Perfluoroelastomer (Compound 2)	K6-	Kalrez 6375	7-10 Days	-20°C to +275°C	-4°F to +525°F
Perfluoroelastomer (Compound 3)	K7-	Kalrez 7075	7-10 Days	-20°C to +327°C	-4°F to +620°F
Fluoroelastomer	H-	Aflas	7-10 Days	-5°C to +204°C	+23°F to +400°F

* For guidance purposes - consult sales office for more information/details.

Media Name	Suggested Seal	Media Name	Suggested Seal	Media Name	Suggested Seal
Acetic Anhydride	P-	Freon, General	E-	Mineral Spirits	Standard
Acetone	P-	Ferric Hydroxide	Standard	Nickel Acetate	P-
Acetylene	Standard	Formaldehyde (50%)	P-	Nickel Suphate	P-
Air (To 200°F)	Standard	Fuel Oils, General	Standard	Nitrogen, Gas	Standard
Air (Above 200°F)	F-	Gasoline	Standard	Nitrous Oxide	Standard
Alcohol, Ethyl	P-	Glycerine (Glycerol)	Standard	Octane	F-
Alcohol, Methyl	Standard	Glycols	P-	Oleum Spirits	Standard
Alkalies, General	Standard	Helium	Standard	OS45 and OS45-1	F-
Ammonia, Aqueous	P-	Heptane	Standard	Oxygen, Non-Breathing	F-
Ammonia, Gas	P-	Hexane	Standard	Paint Thinner	F-
Ammonia, Anhydrous	P-	Hydraulic Oil, Aircraft	Standard	Paraffin	Standard
Ammonia, Hydroxide	P-	Hydraulic Oil, Petroleum	Standard	Peanut Oil	Standard
Aroclor	F-	Hydraulic Oil, Phosphate	P-	Pentane	Standard
Benzene (Benzol)	F-	Hydrogen Gas	Standard	Perchloroethylene	F-
Bleach Solutions	P-	Hydrolube	Standard	Phosphoric Acid (100%)	P-
Brake Fluid, Non-Petro	P-	Isobutyl Alcohol	P-	Photographic Solutions	P-
Bromine Gas	F-	Isopropyl Alcohol	F-	Potassium Acetate	P-
Butane	Standard	Jet Fuel (to 160°F)	JF-	Propane	Standard
Butyl Alcohol	Standard	Jet Fuel (above 160°F)	F-	Propylene	F-
Carbon Dioxide, Dry	Standard	Kerosene	Standard	Propylene Glycol	Standard
Carbon Dioxide, Wet	Standard	Lindol	P-	Silicone Oil	Nitrile
Carbon Monoxide	Standard	LP Gas	Standard	Steam, General Service	H-
Carbon Tetrachloride	F-	Magnesium Hydroxide	F-	Stoddard Solvent	Standard
Cellulube	P-	Methane	Standard	Sulphuric Acid (100%)	F-
Creosote	F-	Methanol	Standard	Toluene	F-
Crude Oil	F-	Methyl Bromide	F-	Transmission Fluid (A)	Standard
Cutting Oil	Standard	Methyl Ethyl Ketone (MEK)	P-	Trichloroethylene	F-
Diester Lubricants	F-	MIL-H-5606	M1-	Vegetable Oil	Standard
Ethane	Standard	MIL-H-5806	Standard	Water	Standard
Ethanol	Standard	MIL-H-6083	Standard	Water, Distilled	Standard
Ethyl Chloride	Standard	MIL-H-7083	Standard	Water, Dionized	Standard
Ethylene Glycol	P-	Mineral Oils	Standard	Water, Sea	P-

Glossary of Terms

3A Symbol for 3A Sanitary Standards Symbol Administrative Council. The 3A Sanitary Standard were created by the dairy industry as a voluntary benchmark for product performance and sanitary safety. The standard, collaboratively developed by a group of processors, suppliers, regulatory officials and sanitation specialists, is accepted by federal, state and local regulatory authorities. Our products have earned the 3A symbol, through third party verification. This assessment makes certain each product conforms in all respects to the published standards. Dixon Sanitary is proud to be a participant in the 3A program.

3A Finish Product surface finish equivalent to 150 grit or better OD, and 180 grit or better ID. A maximum of Ra 32 microinch (0.8 micron) is indicated.

ABS (Acrylonitrile-butadiene-styrene) a thermoplastic resin with an excellent resistance to acids, bases, salts and some solvents. It is heat resistant to 230° F.

ANSI American National Standards Institute, Inc.

ASME American Society of Mechanical Engineers.

ASTM American Society for Testing and Materials.

Acme Thread A flat grooved helical ridge on a nut or bolt. This typically has a 29° included angle. Used on bevel seat, John Perry fittings and IDF.

Anneal Stress relief of stainless steel, a heat treatment to remove the stresses generated in forming and welding operations. This heat treatment is best done under controlled atmosphere or vacuum to maintain the mill finish. The fittings are not quenched, as in solution annealing; this would reintroduce residual stresses. Done correctly, parts are processed to provide minimum residual stresses and full corrosion resistance.

Anodize A process for aluminum, similar to zinc or chrome plating steel, in which an aluminum part is electrically charged then, dipped in various chemicals to produce various colours and/or surface hardness.

API American Petroleum Institute

Available NPSH (Net positive suction head) A characteristic of the system and is defined as the energy which is in a liquid at the suction connection of the pump (regardless of the type of pump) over and above that energy in the liquid due to its vapor pressure.

Bright Anneal Annealing in a protective medium to prevent discoloration of the surface.

Bright Annealed Finish A silvery satin surface, approximately the mill finish of stainless steel.

Buna Synthetic rubber, a copolymer of acrylonitrile and butadiene.

Burst Pressure The pressure at which rupture occurs.

Cavitation When the NPSH required by the pump is greater than the NPSH available by the system, cavitation occurs. Vapor is formed and moves along with the stream. These vapor bubbles or “cavities” collapse when they reach regions of higher pressure on their way through the pump cavities are forming in the liquid being pumped. When these cavities form at the suction of the pump several things happen all at once.

- Loss in capacity
- Loss of head (pressure)
- The efficiency drops
- The cavities or bubbles will collapse when they pass into the higher regions of pressure causing noise, vibration, and damage to many of the components

Glossary of Terms

CW Clockwise.

CCW Counter clockwise

Chamfer To cut an angle on the hose tube aid in stem insertion and to prevent the hose end from flaring when a stem is inserted.

Clamp A device used to join mechanical parts, fittings, ensuring a quick leak-proof connection and enabling easy take down.

Cold Flow Continued deformation or movement of rubber or PTFE under stress.

Compression Set The deformation that remains in rubber or PTFE after it has been subjected to and released from stress such as a clamp. The longer the stress is maintained the more definitive the deformation.

Coupling A device at the end or ends of a length of hose that allows a connection to be made.

Crimping The act of forming the metal sleeve or ferrule of a hose fitting with a surrounding series of die segments to compress the hose within the fitting. The crimping process changes the shape of the entire circumference and length simultaneously. Often interchanged with the term "swaged". **DIN** Deutsches Institut für Normung - German National-standards Organisation.

Double-Acting (DA) Pneumatic Actuator Any pneumatic actuator which uses air to drive the actuator output shaft in both the open and close direction. The air supply is piped to one side of a piston-drive or a diaphragm while the air contained on the opposing side is exhausted.

DN Diameter nominal.

DPDT Double pole-double throw, a switch.

Durometer An instrument for measuring the hardness of rubber by resistance to penetration.

Durometer Hardness A numerical value which indicates the resistance to indentation of the blunt indenter of the durometer.

EPDM Ethylene propylene diene monome, a synthetic rubber.

Elastomer Any of various elastic substances resembling rubber.

Electric Actuator An electro-mechanical device used to open and close or modulate a valve. The actuator (which is mounted and coupled to the valve in similar fashion as the pneumatic actuator), operates the valve using an electric motor driving a gear train. While the basic function of the electric actuator is similar to the pneumatic, there are distinct differences in the application and flexibility of the two types, and these differences should be considered to select the proper type.

Electric Failsafe Actuator Electrically driven actuator that contains an internal spring to close the valve on loss of electricity.

Encapsulation The enclosing of material by an encapsulant for protective purposes. In a ball valve the ball is encased in PTFE, preventing the material flowing through the valve from getting behind the ball causing contamination problems.

Expansion Ring Typically refers to a type of fire hose couplings that are attached by expanding a sleeve (usually brass) outward to compress the hose against the wall of the bowl of the coupling.



Glossary of Terms

External Swage (Swaging) A ferrule is passed through a reducing die, usually split, to bring the ferrule O.D. down to a predetermined size (for proper coupling retention) forcing the hose tube down into the stem serrations.

Fail-Closed Spring return pneumatic actuator is applied to the valve such that the spring will drive the valve to the closed position upon loss of air (may be termed air-to open).

Fail-Open Spring return pneumatic actuator is applied to the valve such that the spring will drive the valve to the open position upon loss of air (may be termed air-to close).

Flow Coefficient (Cv) Cv is defined as the flow rate in U.S. gallons of water (at 60°F) that will pass through the valve in one minute with a differential pressure across the valve of 1 PSI.

Ferrule A collar placed over a hose end to attach the fitting to the hose. The ferrule may be crimped or swaged, forcing the hose against the shank of the coupling, or the shank may be expanded, forcing the hose out against the ferrule, or both.

Fitting A small part of an apparatus (may be detachable).

Fluorocarbon Elastomer known as Viton® a registered trademark of DuPont.

Friction loss The part of the total loss that occurs as the fluid flows through straight pipe.

Gripping Finger The part of the clamp that goes over and behind the stem collar to aid in clamp retention.

Hard Coat An anodising process in which the surface hardness of aluminum becomes similar to or greater than that of case hardened steel.

ISO5211 International standard for actuator and valve interface.

IDF International Dairy Federation.

JIC Joint Industrial Committee

JIC Thread Typically refers to the threads on hydraulic fittings having 37° conical sealing surfaces.

Internal Expansion (IX) A plug (or bullet) is pulled through a stem or a set of blades (fingers) increase the stem I.D. to the plug O.D. or a predetermined setting when using expansion blades (fingers). This forces the stem serrations into the hose tube and the hose cover into the serrations of the ferrule.

Laminar Flow The resistance of flow as a liquid is moved through a pipe due to viscous shear stresses within the liquid and turbulence that occur.

Manual Override Any mechanical device by which an automated valve may be manually operated. On smaller actuators, this may simply be wrench flats on the output shaft of the actuator. Larger actuators may require a more sophisticated system, such as de-clutchable hand wheels, manual gears, jack screws or hydraulic hand pump over-ride.

Maximum-Shut-Off Pressure (Delta-P) The pressure of the media flowing into the valve against which the valve will have to close.

Media The material flowing through the valve.

MSHA Mine Safety and Health Administration.

Modulating Service Proportional positioning of a valve between the open and closed position. Used for flow control processes.

Glossary of Terms

NAMUR International Standard of Interface for actuator accessories connections.

NEMA Rating National electrical code ratings for electrical component enclosures.

NEMA 4 Weather-proof enclosure suitable for indoor/outdoor applications to protect from windblown dust, rain or hose-directed water.

NEMA 4x Offers the same protection as NEMA 4 with the addition of corrosion resistance.

NEMA 6 Enclosure that may be submerged up to six feet for 30 minutes.

NEMA 7 Enclosure for hazardous locations must be capable of withstanding an internal explosion of gases so as not to ignite an external gas-air mixture.

Net Positive Suction Head Amount of energy in the liquid at the pump datum. It must be defined to have a meaning, as either available or required NPSH.

Neoprene Synthetic rubber, chemically and structurally similar to natural rubber.

Nipple The section of the fitting that is inserted into the hose. Also known as the shank of a coupling.

Nominal Size A dimensional value assigned for the purpose of convenient designation.

On-Off Service When the valve is being used to start or stop flow by being cycled to the full open or full closed position.

Operating Pressure The pressure at which system functions. Also known as working pressure.

Permanent Fitting The type of fitting which, after it is applied, cannot be removed for reuse.

Polymer A macromolecular material formed by the chemical combination of monomers having the same or different chemical composition.

Pneumatic Actuator An air operated mechanical device used to open and close or modulate a valve. The actuator, which is mounted to the valve by a bracket and coupled to the stem, is designed to convert air pressure into mechanical force sufficient to operate the valve.

Polish To make smooth and shiny by rubbing. Fittings may be machine polished to 180 grit finish. Polish is ID, OD, or both per customer request.

Polypropylene A lightweight synthetic plastic.

Pressure The force per unit area applied on a surface in a direction perpendicular to that surface.

Pressure Head Must be considered when a pumping system either begins or terminates in a tank which is under some pressure other than atmospheric. The pressure in such a tank must first be converted to feet of liquid. A vacuum in the suction tank or a positive pressure in the discharge tank must be added to the system head, whereas a positive pressure in the suction tank or vacuum in the discharge tank would be subtracted. The following is a handy formula for converting inches of mercury vacuum into feet of liquid.

$$\text{Vacuum, ft of liquid} = \frac{\text{Vacuum, in. of Hg} \times 1.13}{\text{Sp. Gr.}}$$

Proof Pressure A specified pressure which exceeds the hose assemblies rated working pressure to indicate its reliability at normal working pressure. Follow R.M.A.'s testing guidelines for specific pressures and duration's for various types of hose.

The above forms of head, namely static, friction, velocity, and pressure, are combined to make up the total system head at any particular flow rate.

Glossary of Terms

PSI Pounds per square inch.

PSIG Pounds per square inch gauge.

PTFE Tetrafluoroethylene, DuPont's PTFE, is a high performance thermo plastic polymer that has excellent dielectric strength, chemical and temperature resistance.

Required NPSH A characteristic of the pump design. It is determined by test or computation and is the energy needed to fill a pump on the suction side and overcome the friction and low losses from the suction connection to that point in the pump at which more energy is added. Required NPSH varies with pump design, pump size and operating conditions and is supplied by the pump manufacturer.

Santoprene A thermoplastic elastomer, a rubber-like material that complies to FDA requirements.

Service Temperature The maximum and minimum temperature of the media.

RJT Ring Joint Type.

RMA Rubber Manufacturers Association.

Reusable Fitting The type of fitting that is designed to be removed from a hose and recoupled on another hose.

SAE Society of Automotive Engineers.

SAE Threads Similar to J.I.C. except 45° conical sealing surfaces.

Silicone Dimethyl silicone, a synthetic rubber.

Sintering Heat process in which powdered metal particles are heated to near melting point, fusing the metal granules together.

Safety Factor A ratio used to establish the working pressure of a hose based upon the burst pressure.

Typical Safety Factors are as follows:

1. Water hose up to 150 psi WP: 3 to 1.
2. Hose for all other liquids, solid materials suspended in liquids or air and water hose over 150 psi WP: 4 to 1.
3. Hose for compressed air and other gases: 4 to 1.
4. Hose for liquid media that immediately changes into gas under standard atmospheric conditions: 5 to 1.
5. Steam hose: 10 to 1.

SCFM Standard Cubic Feet per Minute. Typically refers to the amount of compressed air a compressor.

Serration The part of the shank (stem) that grips the hose tube.

Shank The section of the fitting or coupling that is inserted into the hose.

Sintered Process in which powdered metal is formed in a mould under extreme pressure to form a finished part.

SMS Swedish Metric System.

SPDT Single pole double throw switch.

SPST Single pole single throw switch.

Glossary of Terms

Spring-Return (SR) Pneumatic Actuator Any pneumatic actuator which contains a single coil spring or group of coil springs to oppose the movement of a piston or diaphragm. As air moves the piston or diaphragm the spring is compressed. When the air supply is discontinued and exhausted, the spring extends and drives the piston or diaphragm in the opposite direction. This type of actuator is normally used for applications where it is necessary for the valve to move to the open or close position upon loss of air supply, whether by design or by system failure.

Static Discharge Head The vertical distance in feet between the pump centerline and the point of free discharge or the surface of the liquid in the discharge tank.

Static Head The pressure at any point in a liquid can be thought of as being caused by a vertical column of the liquid which, due to its weight, exerts a pressure equal to the pressure at the point in question. The height of this column is called the "static head" and is expressed in terms of feet of liquid. **Stem Torque** The force required at the valve stem to open or close the valve against system pressure and service conditions.

Suction Head Exists when the source of supply is above the centerline of the pump. Thus the static suction head is the vertical distance in feet from the centerline of the pump to the free level of the liquid to be pumped.

Suction Lift Exists when the source of supply is below the center line of the pump. Thus the static suction lift is the vertical distance in feet from the center line of the pump to the free level of the liquid to be pumped.

Supply Pressure The plant air supply pressure available to operate a pneumatic actuator (plant air).

Surge A rapid rise or decrease of internal pressure.

Torque A twisting or turning force. Usually measured in inch pounds (in-lbs) or foot pounds (ft-lbs)/(force through a distance).

Total Dynamic Discharge Head (hd) The static discharge head plus the velocity head at the pump discharge flange plus the total friction head in the discharge line. The total dynamic discharge head, as determined on pump test, is the reading of a gauge at the discharge flange, converted to feet of liquid and corrected to the pump centerline, plus the velocity head at the point of gauge attachment.

Total Dynamic Suction Head (hs) The static suction head plus the velocity head at the pump suction flange minus the total friction head in the suction line. The total dynamic suction head, as determined on pump test, is the reading of the gauge on the suction flange, converted to feet of liquid and corrected to the pump centerline, plus the velocity head at the point of gauge attachment.

Total Dynamic Suction Lift (hs) The static suction lift minus the velocity head at the pump suction flange plus the total friction head in the suction line. The total dynamic suction lift, as determined on pump tests, is the reading of a gauge on the suction flange, converted to feet of liquid and corrected to the pump centerline, minus the velocity head at the point of gauge attachment.

Total Head (H) or Total Dynamic Head The total dynamic discharge head minus the total dynamic suction head or plus the total dynamic suction lift.

$$\text{TDH} = \text{hd} + \text{hs} \text{ (with suction lift)}$$

$$\text{TDH} = \text{hd} - \text{hs} \text{ (with a suction head)}$$

Total Static Head The vertical distance in feet between the free level of the source of supply and the point of free discharge or the free surface of the discharge liquid.

Tube The innermost part of the hose that's purpose is to contain the media being transported. Usually, rubber compounds or plastics are blended to give the tube specific properties so that it is compatible with certain media.



Glossary of Terms

Tube Fitting A length of tubing formed into a usable shape either welded to an apparatus or welded to ferrules for use in an apparatus.

Tubing A piece or length of tube.

Tumble Polish Surface A uniform finish applied by vibratory equipment to stainless steel, varying from matt grey to bright, depending on media used. This process may cause work hardening on the surfaces.

Turbulent Flow Irregular flow that is characterized by tiny whirlpool regions. The velocity of this fluid is definitely not constant at every point.

UHMW Ultra High Molecular Weight. Next generation of chemical hoses after cross-linked polyethylene having a thin tube liner made from extremely dense material giving it excellent chemical resistance properties.

Velocity Head (hv) The energy of a liquid as a result of its motion at some velocity V. It is the equivalent head in feet through which the water would have to fall to acquire the same velocity, or in other words, the head necessary to accelerate the water. Velocity head can be calculated from the following formula:

$$H = \frac{V^2}{2g}$$

Where $g = 32.3$ ft/second

$V =$ liquid velocity in feet per second

The velocity head is usually insignificant and can be ignored in most high head systems. However, it can be a large factor and must be considered in low head systems.

Victaulic Groove A style of couplings that has a groove cut near the end of the stem where threads would typically be. The couplings are attached using a "C" shaped clamp that fits into the grooves on the stem.

WOG Water, Oil, Gas. Pressure rating for valves handling these products. This does not include steam.

Welding Join two (or more) pieces of material by applying heat to produce a localized union through fusion across the interface.

For sanitary fittings, a ferrule is attached to the ends of a tube fitting by TIG welding without the addition of filler metal. Tube fittings can then be joined with clamps and gaskets to form parts of a system.

Work (Strain) Hardening An increase in hardness and strength caused by plastic deformation at temperatures below the annealing ranges.

WP Working Pressure

Working Pressure The maximum pressure to which a hose assembly will be subjected to including pressure surges.

XLPE Cross-Linked Polyethylene. Tube material that has good chemical resistance properties.

Dixon Terms & Conditions

Limited Warranty

Dixon Group Europe Ltd (herein called "Dixon") warrants the products described herein, and manufactured by Dixon to be free from defects in material and workmanship for a period of one (1) year from date of shipment by Dixon under normal use and service. Its sole obligation under this warranty being limited to repairing or replacing, as hereinafter provided, at its option any product found to Dixon's satisfaction to be defective upon examination by it, provided that such product shall be returned for inspection to Dixon's factory within three (3) months after discovery of the defect. The repair or replacement of defective products will be made without charge for parts or labour. This warranty shall not apply to: (a) parts or products not manufactured by Dixon, the warranty of such items being limited to the actual warranty extended to Dixon by its supplier; (b) any product that has been subject to abuse, negligence, accident, or misapplication; (c) any product altered or repaired by others than Dixon; and (d) to normal maintenance services and the replacement of service items (such as washers, gaskets and lubricants) made in connection with such services. To the extent permitted by United Kingdom law, this limited warranty shall extend only to the buyer and any other person reasonably expected to use or consume the goods who is injured in person by any breach of the warranty. No action may be brought against Dixon for an alleged breach of warranty unless such action is instituted within one (1) year from the date the cause of action accrues. This limited warranty shall be construed and enforced to the fullest extent allowable by applicable United Kingdom law.

OTHER THAN THE OBLIGATION OF DIXON SET FORTH HEREIN, DIXON DISCLAIMS ALL WARRANTIES, EXPRESS OR IMPLIED, INCLUDING BUT NOT LIMITED TO ANY IMPLIED WARRANTIES OF MERCHANTABILITY OR FITNESS FOR A PARTICULAR PURPOSE, AND ANY OTHER OBLIGATION OR LIABILITY. THE FOREGOING CONSTITUTES DIXON'S SOLE OBLIGATION WITH RESPECT TO DAMAGES, WHETHER DIRECT, INCIDENTAL OR CONSEQUENTIAL, RESULTING FROM THE USE OR PERFORMANCE OF THE PRODUCT.

Some products and sizes may be discontinued when stock is depleted, or may require a minimum quantity for ordering.

Dixon Group Europe Ltd is committed to a policy of continuous development, and as such, the above detailed specification and may be subject to change without notice. Dixon Group Europe Ltd reserves the right to change and modify designs and specification without notice.

Pricing

Dixon will always try to maintain pricing, however, with the fluctuation of material cost we may be forced to change prices. Please be aware pricing is subject to change without notice.

Freight/Postage & Carriage Charges

Postage & carriage charges are at the customer's expense and will be charged at current appropriate rates.

Returns

Dixon will allow its customers to return any product for any reason within 30 days of shipment, provided it is received in a saleable condition. The customer must call to receive a CCR number prior to returning goods to Dixon and shipping will be at the customer's expense, unless it is determined Dixon created the reason for the return.

A re-stocking charge of 25% applies to all returns.

Limits of Liability

This catalogue is intended as a product offering. It is not intended to be a user or technical manual. Information in this catalogue is subject to change without notice. All users and distributors of products sold through this catalogue should contact Dixon with questions of use, compatibility's, coupling procedures and life of product. Dixon's full time engineering and test staff is always available to recommend uses and to assist distributors and users with questions.

Copyright

Copyright© 2012 by Dixon Group Europe Ltd.

All rights reserved. This book is copyrighted material. Use, reproduction or copying of it by anyone other than Dixon is strictly forbidden without its express written consent.



Index

Page #	Page No.
3A Standard	141
520-H Ferrules	250

A

A101AS Air/Water Hose	102
A101HP Air/Water Hose	103
A102HP Air/Water Hose	103
A104 Multipurpose Hose	109
A190 Air/Water Hose	104
A210 Water S & D Hose	105
A230 Steam Hose	116
A235 Steam Hose	115
A400EU Heavy Duty Oil Hose	108
A410 UHMWPE Chemical Hose	114
A430 Oil S & D Hose	108
A901 Oil Composite Hose	111
A901AG Vapour Recovery Hose	111
A906 Chemical Composite Hose	112
A911 PTFE Composite Hose	113
A-A-59326B Specification	26-45
Actuated Valves	203-223
Adapters	
- Boss	341, 343
- European Compressor	19
- High Pressure	50-52
- Dry Disconnect/ Dry Break	388-393
Adflex Metal Hose	129
Aero Seal	67
AG Series	282-283
Agricultural Interchange	282-283
Agri-lock Couplings	418-421
Air Fittings	6-21
Air/Water Hose	102-107
Air Hose Couplings	6-19
Air Interlock	365
Air King	15-19
- Clamps	17, 19
- Couplings	15-18
- Crimp Ferrules	18
- Hose End	18-19
- Safety Clips	16
- Washers	18
- Universal	15
Air Relief Valves	187, 352-353
Amoured Hose	133-135
APC Clamp Gasket	166
API	
- Bottom Rack Loading	362
- Certified Couplings	251-252
- Compatible Rack Cord	379
- Dust Cap	62
- Optic System	376-377
- Valves	361
Aseptic Diaphragm Valve	178
ASME: BPE	175-178
ATEX	373-377

B

B.E.S.A.FE	447
Baku PVC Hose	110
Ball Nozzles	66
Ball Valves	188-196, 404-405
- 2 Way 3 Piece	189
- 3 Way Encapsulated Hygienic	192
- Automation	195-196
- Encapsulated 2 Way 3 Piece	190
- Multi Port 3 Way	193
- Multi Port 4 Way	194
- Non-Encapsulated 2 Way 3 Piece	191
Band It Clamps	72
Barrell Nipple	82
Bayco	348-401
Beverage Hose	117-122
Biopharm Fittings	175-178
Blank Plug/Cap	83-85
Blow Gun	21
Blow Out Prevention Safety Coupling	296
Boss	336-346
- Adapters	341
- Clamps	344-345
- Couplings	338-346
- Coupling System	338
- Hose Menders	342
- Stems	340
- Wing Nuts	340
Boss Lock	28, 30, 32, 34, 38, 42
- Clips	43
- Y Piece	42
Bowes Interchange	6-11, 327-332
BPE Technical Information	495-498
BR Series	319-320
Braided PTFE Hose	128
Brass Crimp Fittings	94
Brass Hose Fittings	93
Brewery Hose	117-122
BS EN14423:2004	
- Steam Hose Coupling	346
Buckles	70-73
Bulkstream Hoses	123-127
Butterfly Valves	197-202, 357-359

C

Cam & Groove	24-56
- 90 Degree Elbow	40-41
- A-A-59326B	26-45
- Andrews	27, 29, 31, 34-35, 38-40, 42-44
- Boss Lock	28, 30, 32, 34, 38, 42
- Crimp Style	46-48
- DIN BS EN	14420 49
- Dust Plugs/Caps	36-39
- EZ Boss Lock	28, 30, 32, 42, 45, 49
- Handle Assemblies	42-43
- High Pressure	50-52
- Line Drawings	24
- Seals	54-56
- Type A	26

- Type B	27
- Type C	29
- Type D	31
- Type E	33
- Type F	35
Carbon Steel Ball Valve	407
Cejn Interchange	324-326
Centre Punch Clamps	72
Centrifugal Pump	226
Check Valves	183-187
- Air Blow	186
- Ball	188
- Spring	184
Checkmate Retain Overfill System	371-373
Chemical Hose	108-114
CJ Series	324-326
Clamp Type BS: 4825 Part 3	
- Couplings & Gaskets	59-168
- Butt Weld Ferrule	160
- Double Pin Heavy Duty	159
- External Crimp Ferrule	161
- Gaskets	162-164
- Hose Tail	161
- Hygienic Bolted	159
- Seal	162-164
- Short Weld Ferrule	160
- Single Pin Heavy Duty	159
- Single Pin Squeeze	159
- Solid Ferrule Blank Disc	160
Clamping Tools	70
Clamps	59-74
- Aero Seal	67
- Band It	72
- Centre Punch	72
- Double Bolt	61
- Double Ear	71
- Heavy Duty	60
- Hi Torque	65
- Hygienic	159-168
- Junior	72
- K Series	69
- Safety	74
- Single Bolt Superclamps	66
- Single Ear	7
- Spiral	61
- T Bolt	60
- Ultra Lok	72
- Worm Gear	62-64
CM Series	310-312
Composite Hose	111-113
Corrosion Resistance Guide	459-464
Coupling Inserters	243
Crimp Couplings	46, 240-257, 437
Crimp Dies	95-96
Crimp Recommendations	480-487
Crimp Style	
- Cam & Groove	46
- Ferrules	48, 439
- King Combination Nipples	437
- Sleeves	47, 438
Crimping Tool	95-96
Custom Built Hoses	123-127
CVV Series	305

D

D Series	313-318
Dairy Standard - Polished OD	173-174
- Elbows	173
- Reducers	174
- Tees	173
- Y	174
Deadman Spring Return Valve	406
Delikatesse PVC Hose	122
Delivery Nozzle	366-367
Delvac PVC Hose	106
DF Series	313-318
Diameter Tape	137
Dies	95-96
DIN 11851/11887 Couplings & Gaskets	147-150
- Blank Cap	147
- Blank Nut	147
- External Crimp Ferrule	149
- External Crimp Stem	149
- Gasket	150
- Round Nut	147
- Spanner	147
- Weld Liner	148
- Storz	394-397
Double Bolt Clamps	61
Double Ear Clamps	71
Dry Break Cam & Groove Adapters	388-393
Dry Break Cam & Groove Couplings	388-393
Dry Bulk Tanker Products	351-359
Dry Disconnect Adapters	388-393
Dry Disconnect Couplings	388-393
Dry Mates	53

E

E Series	306-308
EA Series	309
Elbow 45°	83-84
Elbow 90°	83-84
Electric Actuation	222
EN 14420-6:2004 Tank Wagon Couplings	398-399
Enerpac Interchange	304
Envelope Gasket	166
European Compressor Couplings	19
European High Flow Interchange	324-326
European Screw Together Series	305
Excess Flow Sensor Check Valve	414
External Crimp	257-258
External Swage	255-256
EZ Boss Lock	28, 30, 32, 42, 45, 49

F

F Series	313-318
----------	---------

Fabrication & Tubing	236
Ferrule Colour Coding	259
Ferrule Crimping Tool	95
Filters	227-232
Filtration Systems	353
Finish Designations	141
Fire Connections	78-89
Fire Guard	137
Fire Hose Couplings	78-89
Fire Jackets	78-89
Fire Products	78-89
Fire Protection Valves	78-89
Flanged Gasket	164
Flanges - Stainless Steel	87
Flanged Hose Spigots	85
FloTech Comparison Chart	380-381
FloTech Overfill Prevention	369-381
FlowBoss Washdown Gun	440
Fluid Compatibility Guide - Dixon Quick Couplings	500
Flushface Interchange	288-290
Food Grade Interchange	278
Food Hose	117-122
Foot Valve	410
Forged Steel Hammer Union	265

G

Gasket Sizing Guide 1	67-168
Gaskets 146, 150, 154, 158, 162-166, 368, 427	
Gate Valve	404-405
Gauges	96
Geka Type Couplings	428
Gravity Drop Adapter	363
Grinnell Couplings	422-425
Ground Joint Seal Couplings	339
Grounding Ball	377
Grounding Studs	368
GSM Hose	133-135

H

H Series	273-277
H Series ISO-B	278
Hammer Unions	265
Heavy Duty Clamps	60
Hexagon Nipple	82
Hi Torque Clamps	65
High Pressure Cam & Groove	50-52
High Pressure Coupling	294-295
High Purity Fittings	175-178
- Aseptic Diaphragm Valve	178
- Auto Weld Ferrules	176
- Elbows	175
- Gaskets 1	77

- Heavy Duty Clamp	177
- Reducers	175-176
- Tees	175
Hingelok Coupling	425
Holedall Swaged Couplings	240-267
- External Crimp	257-258
- External Swage	255-256
- Flanged Stem & Ferrules	247
- Hygienic	247-248
- Internal Expansion	245-248
- Petroleum	249-252
- Rotary	263-264
- Swaging Machines	260
Hookie Hook Hose Lifter	259
Horizontal Swing Check Valve	356
Hose	100-137
- A101AS	102
- A101HP	103
- A102HP	103
- A104	109
- A160HW	123
- A170SW	124
- A190	104
- A210	105
- A230	116
- A235	115
- A410	114
- A430	108
- A499EU	108
- A600HW	125
- A600SW	126
- A901	111
- A901AG	111
- A906	112
- A911	113
- Adflex Metal	129
- Air Hose	102-107
- Amoured	133-135
- Baku PVC	110
- Beverage	117-122
- Braided PTFE	128
- Brewery	117-122
- Bulkstream	123-127
- Chemical	108-114
- Composite	111-113
- Custom Built	123-127
- Delikatesse PVC	122
- Delvac PVC	106
- Diameter Tape	137
- Fire Guard	137
- Food	117-122
- GSM	133-135
- Hygienic	117-122
- Hyparflex Metal	131
- Irribulk PVC	106
- Lifter	259
- Menders	435
- Metallic	127-122
- Multi-Purpose	108-114
- Oil	108-114
- PREMflex	107
- PREM-vin PVC	121
- PTFE	128
- PVC	106-107, 110, 121-122
- Restraint	20
- San-Hygienic Crusha	117
- San-Hygienic Food Grade	117
- San-Hygienic Premium	118
- San-sil Silicone	120

N

- Spigots	436
- Spiral Guard	137
- Steam	115-116
- Suparflex Metal	126
- UHMWPE	114
- Water	102-107
Hose Assembly Safety	448-453
Hose Coupling Safety	444-445
HT Series	288-290
Hydrant Adapters	78-89
Hydrant Nozzles	78-89
Hydrosttic Test Pump	244
Hygienic	138-237
- Actuation	203-223
- Bends, Tees & Reducers	138-176
- Clamp Type Couplings & Gaskets	159-168
- Clamps	159, 177
- Couplings	138-176
- DIN Couplings & Gaskets	147-150
- Fabrication	236
- Fittings	138-176
- Hose Assemblies	117-122
- IDF Couplings & Gaskets	151-154
- Pressure Gauges	182
- RJT Couplings & Gaskets	143-146
- SMS Couplings & Gaskets	155-158
- Spanner	143, 147, 151, 155
- Valves	183-235
Hyparflex Metal Hose	131

I

IDF BS: 4825 Part 4 Couplings & Gaskets	151-154
- Blank Cap	151
- Expanding Liner	152
- Expanding Male	152
- External Crimp Ferrule	153
- External Crimp Stem	153
- Hex Nut	151
- Seal	154
- Spanner	143, 147, 151, 155
- Weld Liner	152
- Welding Male	152
In Line Sight Glass	356
Industrial Interchange	313-318
Instantaneous Couplings	78-89
Instrumentation Fittings	90-93
Internal Expansion	245-248
Irribulk PVC Hose	106
ISO 15171-1 Diagnostic Interchange	297
ISO 16028 Interchange	288-290
ISO A Interchange	280-281
ISO B Interchange	288-290
ISO7241 Series Interchange	273-277

J

J Series	321-323
Junior Smooth Clamps	72

K

K Series	280-281
K Series Clamps	69
King Combination Nipples 4	32-436
King Crimp Cam & Groove	46-48
King Safety Cable Hose Restraint	20

L

Lanyards	17
Lightweight Couplings	24
Low Pressure Tank Equipment	400
Lugged Water	429-431
Loading Arm	384, 387

M

MacDonald Interchange	6-11, 327-332
Measurement & Conversion Information	465-468
Metallic Hose	128-132
Mould Coolant Interchange	310-312
MSHA Regulations	500
Multi-Purpose Hose	108-114

N

N Series	6-11, 327-332
Nozzles	366-367
Non Conductive Hose	109
Nut	
- Hex/Round	143, 147, 151, 155
- Blank	143, 147, 151, 155
- Wing	341

O

Oetiker Clamps	71
Oil Hose	108-114
Optic Sensor Tester	377
OSHA Regulations	499
Overfill Prevention Socket	378
Overfill System	369-377

P

P Series	12-14, 333-335
PD Series	297
Petroleum Couplings	251
Petroleum Tanker Products	360-668
Pipe Fittings	82-85
Pipe Hangers	180
Plastic Fittings	97

Pneuclean	353
Polished Fittings	169-172
- Elbows	169
- Reducers	171
- Tees	170
Polypropylene Valve	409
Preformed Band Clamps 6	8
PREMflex PVC Hose	107
PREM-vin PVC Hose	121
Pressure Equipment Directive	451
Pressure Gauges	96, 181
Pressure Recommendations	454-458
PTFE Hose	128
Pump Hose Fittings	253-254
PVC Hose	106-107, 110, 121-122

Q

Quick Release Couplings	268-335
- Fluid Compatibility Guide	500

R

R/OM Type Retain Overfill System	374-375
Rack & Pinion Actuators	212-221
Rack Cord	379
Rectus 21 Interchange	319-320
Replacement Probes	369-377
Returned Goods	508
Rigidlok Couplings	423
RJT BS: 4825 Couplings & Gaskets	143-146
- Blank Cap	143
- Expanding Liner	144
- External Crimp Ferrule	145
- External Crimp Stem	145
- O-Ring	146
- Pressed Liner	144
- Spanner	143
- Welding Liner	144
- Welding Male	144
Rotary Couplings	262-264

S

S.T.A.M.P.E.D	446
Safety Check Valve	414
Safety Clamps	74
Safety Clips	16
Safety Vented Ball Valve	406
Sample Valves	233-235
San-Hygienic Crusha Hose	117
San-Hygienic Food Grade Delivery Hose	119
San-Hygienic Food Grade Hose	117
San-Hygienic Premium Hose	118
San-sil Silicone Hose	120
Scovill Couplings	249

Screw Together Couplings	304-305
Seals	
- Cam & Groove	54-56
- DIN	150
- IDF	154
- RJT	146
- SMS	158
- Storz	397
- Tankwagon	398-399
Seat Valves	224-225
CM Series	225
CT Series	225
Sequential Vapour Vents	365
Sight Glass	
- End Caps	79
- In Line	179
- Replacement Parts	179
Single Bolt Superclamps	66
Single Ear Clamps	71
Skimmers & Strainers	410-413
Smooth Tails	88-89
- Couplings	89
- Fixed	89
- Swivel	89
SMS Unions, Tools & Gaskets	155-158
- Blank Cap	155
- Expanding Liner	156
- Expanding Male	156
- External Crimp Ferrule	157
- External Crimp Stem	157
- Seal	158
- Spanner	155
- Weld Liner	156
- Welding Male	156
Snap-Tite 71 Interchange	291-293
Snap-Tite H/IH Interchange	298-303
Snow Cannon Fittings	50-52
Sockets	378
Spanner	143, 147, 151, 155
Spanner - Double Ended	143
Spiral Clamps	61
Spiral Guard Hose Protection	137
Spray Balls	182
Spud Adapters	341
ST Series	291-293
Steam	
- Ball Valve	407
- Clamps	344-345
- Couplings	336-346
- Hose	115-116
- Interchange	279
Storz	394-397
Straight-Through Interchange	306-308
Strainers	227-232
Strapping	70-73
Suparflex Metal Hose	130
Swage Couplings	240-259
Swaging Machines	260
Swing Check Valves	354-356
Swivel Joints	382-387

T

T Bolt Clamps	60
T Series	304
Tank Wagen Couplings	
- Brass	398-399
- Gaskets	398-399
- Seals	398-399
- Spare Parts	398-399
- Stainless Steel	398-399
Tanker Products	348-401
Tema European Interchange	84
Terms & Conditions	509
Thermo Optic Sensor	373, 375
Thor Interchange	12-14, 333-335
TR Series	284
Trigger Nozzles	367
Truflate Automotive Interchange	321-323
Tube Hangers	180
Tuff Lite	97, 434
TW Couplings	398-399

U

UHMWPE Hose	114
Ultra Lok Clamps	72

V

V Series	298-303
Vacuum Relief Valves	352-353
Valve Automation	203-223
- Bracket Mounted Microswitches	204
- Limit Switches	205
- Postitioners	207
- Proximity Sensors	204
- Rack & Pinion	212-221
- Solenoid Valves	206
- Stainless Steel Actuator	211
- Stainless Steel Canister	209
Valve Information	488-494
Valves	
- Actuated	203-223
- Ball	404-405
- Carbon Steel	407
- Deadman	406
- Foot	410
- Gate	404-405
- Locking Handle	408
- Mini	405
- Polypropylene	409
- Safety Vented	406
- Spring Return	406
- Steam Ball	407
- Vapour	364
- Hygienic	183-235
Vapour Caps	364
Vapour Hose Coupler	365
Vapour Valve	364

VEP Series	285
Victaulic Coupling	426

W

W Series	286-287
Warranty	508
Washdown Guns	440-441
Water Blast Interchange	309
Water Couplings	416-441
Water/Air Hose	102-107
Weld End Pipe Fittings	86
Welding Nipple	82
Whipcheck	20
Wing Style Coupling	294-295
Wing Style Interchange	286-287
Worm Gear Clamps	62-64
WS Series	294-295
WS Series Blowout	296

Alphabetical Part Number Index

In the following index, a • is used to represent a variable. Therefore, to find CVV8F8 or CVV12F12 look for CVV•F•

Part No.	Page No.	ALMFA•X•	420	B5101S•••XX-A	199	BR•GM•-B-E-7	320
A••	17	ALMFR•X•	420	B5101S•••XX-C	199	BR•M•-B-E-7	320
A•••	426	ALMM•X•	421	B5101V•••XX-A	199	BR•S•-B-E-7	320
A••••L-A	251	ALMW•	419	B5101V•••XX-C	199	BS••	344-345
A101AS-T2-•••	102	ALO•	419	B5416MP-A•••	179	BSCCQ•-R•••	228
A101HP•••	103	ALT•F	421	B54BMP-R•••	179	BST••	434
A102HP•••	103	ALT•M	421	B54BMP-SK•••	179	BSVACV-R•••••	228
A104•••	109	AM•	15	B54G-P•••	179	BSVWNS-G•••	230
A16•	123	AM••	15, 18	B7RWWW-R••••••	173	BTN••	441
A17•	124	AM••WF	17	B7RWWW-R••••••P	171	BU•	344-345
A190•••	104	AM•SWIV	16	B7W-R•••P	170	BU••	344-345
A190•••Y	104	AMB•	15	B7WWW-R••••	173	BV2C•-•••CC-A	189
A210•••	105	AMC•	15	B7WWW-R•••P	170	BV2GG•-•••CC-A	191
A2180/XX	352	AMH	18	B9WWW-R•••P	172	BV3S•-LF•••CC-A	192
A2182/XX	353	ARM•••	121	BA•	340	BV3S•-TF•••CC-A	192
A230•••	116	AST••	434	BA•••	441	BV4S•-LF•••CC-A	194
A235•••BK	115	AUS•••BHD	110	BARV-G	187	BV4S•-TF•••CC-A	194
A235•••BU	115	AUS•••FBW	122	BB•	344-345	C•	70
A3180/XX	352	AUS•••GB	107	BB••	340	C•••	422
A400EU•••	108	AUS•••GN	106	BB•••	28	C•••BU	422
A410•••	114	AUS•••GTD	106	BBLV•••	408	CB	340
A430•••	108	AWR••	18	BBU•	344-345	CCF••••	18
A60•	125	AWS•	19	BBU••	344-345	CD	17
A61•	126	B•	340	BBV•••LV	406	CD	344-345
AB••	15, 18	B••	340	BBV•••SR	406	CF•••-•CS	47, 439
AB•••	28	B•••	400	BBV•••ST	407	CF•••-•SS	47, 439
ABC•	15	B••SC	343	BC•••	30, 226	CG•••	70
ABH	18	B2•W-R••••	174	BD	344-345	CH-B•	43
AC•	16, 43	B2•W-R•••P	172	BD•••	32	CH-C•	43
AC•••	30	B24DB-G•••	180	BF•••	94	CH-SS•	43
ACL•	17	B24PPHAP-G	180	BFL•••	94	CJ••	243
ACL•••	43	B24PPSTW-G	180	BFM•••	94	CJ••••SML	243
AD•••	32	B27-3	343	BFMW••••	94	CJ••AH	243
ADA••••	45	B2KS-R•••P	169	BFW•••	94	CJ•BF•-B	325
AG•DC	282	B2S-R•••P	169	BGB•	340	CJ•BF•-S	325
AG•F•	283	B2WCL-R••••	173	BGB••	340	CJ•BM•	325
AG•F•-PV	283	B2WCL-R•••P	170	BGE••	21	CJ•BM•-B	325
AG•OF•-PV	283	B2WK-R••••	173	BGF••	339	CJ•BM•-LG	325
AH•••	38	B2WK-R•••P	169	BH•••	38	CJ•BM•-S	325
ALCS•	418	B31W-R••••••	174	BHSC•••	42	CJ•F•-B	325
ALF•	418	B31W-R••••••P	171	BL00•	366	CJ•F•-LG	325
ALFB•	419	B32W-R••••••	174	BL06•	366	CJ•F•-S	325
ALFF•D	420	B32W-R••••••P	172	BL07•	366	CJ•M•	325
ALFF•E	420	B45AB-R•••	186	BLCA152CS	43	CJ•M•-B	325
ALFF•NP16	420	B45BY-R•••	185	BM••	435	CJ•M•-LG	325
ALFM•X•	421	B45MP-R•••	184	BMS•	342	CJ•S•	326
ALFW•	419	B5101E••••CC-F	201	BMS••	342	CJ•S•-B	326
ALL•	418	B5101E••••CC-G	201	BN••	440	CJ•S•-S	326
ALM•	418	B5101E••••CC-H	201	BN•••	93	CM•F•	310
ALMB•	420	B5101E••••XX-A	199	BR•BF•-B-E-7	319	CM•F•-B	310
ALMF•	419	B5101E••••XX-C	199	BR•F•-B-E-7	319	CM•M•-B	311

CP•	128	DATN/FS	367	ETP	244	FT40•-150	377
CS•••	70	DATN/MS	367	F••	68	FT40•-500	377
CS••••AL	48, 438	DATNC/FS	367	F•••	70	FT451	377
CS••••CS	48, 438	DATNC/MS	367	F••CJBF•-S	324	FT52•	377
CS••••SS	48, 438	DBA•••••	393	F••CJF•-S	324	FT52•-8	377
CSN••	441	DBAF•••••	393	F••CJM•-S	325	FT520	377
CSSR•••	161	DBAV73-2030	393	F16G•••••	142, 149, 153, 157, 162	FT600	379
CVV•BF•	305	DBC•••••	391	F24G•••••	142, 149, 153, 157, 162	FT601	379
CVV•F•	305	DBC77••••GL	391	F32G•••••	142, 149, 153, 157, 162	FT62•	379
D•••	21	DBCL••••	392	F4•G•••••	142, 149, 153, 157, 162	FVS•••CI	410
D•B•	318	DBS6•-200	392	F40G•••••	142, 149, 153, 157, 162	FVS•••EU	410
D•BF•	315	DCSET••	92	F64G•••••	142, 149, 153, 157, 162	G••••	249
D•BM•	317	DD	344-345	FF••/CS	89	G•••E	427
D•E•	314	DDA••••AL	390	FF••/SS	89	G•••T	427
D•F•	315	DDA••••ALFL	390	FLOBOSS-050	440	G2/•••SS	405
D•F•-B	315	DDA••••BR	390	FM••••	441	G3/•••SS	405
D•F•-S	315	DDA••••BRFL	390	FO•••	68	GB•	340
D•H•	314	DDA••••GM	390	FOS•••	68	GB••	340
D•H•-S	314	DDA••••GMFL	390	FRSGX••	136	GBA	340
D•HF•-S-FNS	278	DDA••••SS	390	FS••	68	GBC	341
D•HF•-S-FSB	278	DDA••••SSFL	390	FS••/CS	89	GCA	340
D•HF•-SS-FNS	278	DDC••••AL	389	FS••/SS	89	GCC	341
D•HF•-SS-FSB	278	DDC••••BR	389	FT101 - ATEX	373, 376	GDB•	341
D•K•	314	DDC••••GM	389	FT101-12 - ATEX	373, 376	GDB••	341
D•L•	314	DDC••••SS	389	FT101-18 - ATEX	373, 376	GEBC•••	431
D•M•	317	DDDC•••	390	FT10•	376	GEF•••A	431
D•M•-B	317	DDDP•••	389	FT100	376	GEF•••P	431
D•M•-S	317	DDT1	137	FT100•	376	GEM•••A	431
D•S•	318	DFC••	91	FT100•-12	376	GEM•••P	431
D•S•-B	318	DFVS••	410	FT100-12	376	GF•	339
D•S•-S	318	D-H•F•-	S 278	FT100-18	376	GF••	339
DAL•• AN	26	D-H•F•-SS	278	FT150	373	GF•••	339
DAL•• BB	27	D-H•F•-SV-8	278	FT150•	373	GFAS•	343
DAL•• BN	27	DIN-SMS••/••SP	147, 155	FT155	373, 377	GFAS••	343
DAL•• DB	31	DL•••	61	FT20•	373	GLBLT••	427
DAL•• DN	31	DM•••	435	FT20•P	375	GM•	341
DAL•• DP	36	DM••••ABSS	53	FT200•	374	GM••	341
DAL•• E	33	DM••••DBSS	53	FT200•-12	374	GMAS•	343
DAL•• FB	35	DN••	92	FT201	375	GMAS••	343
DAL•• FN	35	DRC••	92	FT201-12	375	GMC	341
DAL••• AB	26	DSH•••	43	FT201-18	375	GS•	368
DAL••• AN	26	DST••	411	FT210•	374	GV••••BH	404
DAL••• BB	27	E•BF•-B	307	FT210•-12	374	H•••	425
DAL••• BN	27	E•BF•-S	307	FT280•	372	H••••	249
DAL••• DB	31	E•F•	307	FT280•-12	372	H•••••-A	251
DAL••• DN	31	E•F•-B	307	FT281•	372	H•••••-A-BU	251
DAL••• DP	36	E•F•-S	307	FT281•-12	372	H•••••-BU	249
DAL••• E	33	E•M•	308	FT3••SS	378	H•••••L	251
DAL••• FB	35	E•M•-B	308	FT30••	378	H•••••L-A	251
DAL••• FN	35	E•M•-S	308	FT304 BI	378	H•••••L-A-BU	251
DAL••••C	29	E•S•	308	FT304 BVI	378	H•••••NST	249
DAL••••DC	37	E•S•-B	308	FT304 VI	378	H••••BU	425
DAL•••C	29	EA•F•	309	FT40•	377	H•BF•	277
DAL•••DC	37	EAWR•	19	FT40•-1000	377	H•BF•-B	277

H•BF•-S	277	HT•DC	288	LPB••	343	R•	250
H•BF•-SS	277	HT•F•	290	LR•	17	R••	250
H•BNM	82	HT•F•-SS	290	LR•	43	R•••	423
H•DC•	274	HT•M•	290	LS•••	63	R•••BU	423
H•DC•-A	275	HT•OF•	290	LSS•••	63	R•5AS	250
H•F•	277	HT•OM•	290	M	342	R•5BS	250
H•F•-B	277	HTM•••	65	M••	342	R•5CS	250
H•F•-HV	275	HU100•••	265-266	M3700	367	R•5FS	250
H•F•-S	277	HU1002•••	265-266	MAH••	63	R•AAL-A	250
H•F•-SS	277	HU1502•••	265-266	MB•••SS	398	R•AAS	250
H•M•	274	HU200•••	265-266	MBV••	405	R•AAS-A	250
H•OF•	277	HU206•••	265-266	MH••	62	R•AS	250
H•PC	275	HU602•••	265-266	MK•••SS	398	R•BAL-A	250
H•RJTL	144	IB•••	28	MKLR•••BR	399	R•BS	250
H•S••	86	IBV•••	407	MKLR•••SS	399	R•BSS-A	250
H•S45FF	83	IC•••	30	MKSR••	399	R•CAL-A	250
H•S9OFF	83	ID•••	32	MKSR•••SS	399	R•CS	250
H•SCTN	83	IDF•-SP	151	MS••	342	R•CSS-A	250
H•SFS	84	IH•••	38	MS••X••	342	R•DAL-A	250
H•SHN	82	J••	61	MS•X•	342	R•DSS-A	250
H•SHPH	84	J•••	43	MSA	342	R•ESS-A	250
H•SHPS	85	J•B•	323	MSB	342	R125AAS-A	250
H•SHS	84	J•BF•	322	MSC	342	R125AS-A	250
H•SLN	85	J•F•	322	N•BF•	7, 328	R125BS-A	250
H•SRC	83	J•F•-B	322	N•BM•	6, 327	R125CS-A	250
H•SSE	86	J•M•	322	N•CS•	7, 9, 328, 330	R125DS-A	250
H•SUFF	84	J•M•-B	322	N•DC	10, 331	R125ES	250
H•SWNM	82	J•S•	323	N•F•	7, 328	R125ES-A	250
H50••-BU	252	J2E2	323	N•F•-B	9, 330	R12P	250
H57••	253	J2H2	323	N•F•-B-LS	7, 328	R12P1••0	250
H6••	254	J2K3	323	N•M•	6, 327	R1375BS	250
HA••••	245-247, 255-258	J2L3	323	N•M•-B	9, 330	R1375CS	250
HA•••••-•••-3BLU	248	JX••	61	N•M•-B-LS	8, 329	R1375DS	250
HA•••••-•••-4BLU	248	K•BF•	281	N•S•	9, 330	R1375ES	250
HA•••••-•••-5BLU	248	K•DC	281	N•Y•N	10, 331	R15AAAS-A	250
HA••••T	245-247, 255-258	K•F•	281	NFSGX••	136	R15AAS-A	250
HA••••TZP	245-247, 255-258	K•OF•	281	P•F•	12, 333	R15AS-A	250
HA••••ZP	245-247, 255-258, 259	KLW••	431	P•M•	13, 334	R15BS-A	250
HA02••	142, 149, 153, 157	KM•••	435	PB•••BL	28	R15CS-A	250
HA08••	170	KNW••	368, 430	PC500•	353	R15DS-A	250
HA0900-•	259	KRW••	430	PD•F•	297	R15ES-A	250
HB•••	434	KS•••••	69	PD•M•	297	R15GS	250
HHTTP	243	KSF•••B	429	PD•OM	297	R1AAAS-A	252
HP•	65	KSF•••M	429	PG•••	21	R1AAS-A	252
HPA••	50	KSF•••SS	430	PG•••••	98	R1AS-A	252
HPCG••	50	KSM•••B	429	PPN••	434	R1BS-A	252
HPH••	52	KSM•••M	429	PTLS•••••	413	R1CS-A	252
HPSC••	51	KSM•••SS	430	PTP	244	R1DS-A	252
HS•F•	279	KVW••	368	PV•••	409	R1ES-A	252
HS•F•-B	279	L•••	424, 426	PVFP•••	409	R25AAL-A	252
HS•F•-S	279	L•••BU	424	PYLS•••••	413	R25ASS-A	252
HSS•••	62	L14AM7-R	160	QDF••M	19	R25BSS-A	252
HT•BF•	290	LP••	343	QDHE••M	19	R25CSS-A	252
HT•BF•-SS	290	LP••-80	343	QDM••M	19	R25DAL-A	252

R25DS	252	RST••A	433	T•••	426	VEP•OF•	285
R25DSS-A	252	RST••CS	437	T•BF•	304	VK•••SS	398
R25EAL-A	252	RSTB••	433	T•DC	304	VK•••SS	398
R25ES	252	RSTB••CS	437	T•F•	304	VR4•••	364
R25ESS-A	252	RSTV••CS	437	T•F•-SS	304	VR4•••PL	364
R2ES	252	SANB•••	117	T•S-•••PL	175	VR60••SQ	365
R2FS	252	SANB•••-DEL	119	T•S-•••PM	175	VRC3000AL	365
R3AAAL-A	252	SANB•••-PREM	118	T-100IX	260	W•BF•-B	287
R3AAAS	252	SANC•••	117	T-20IX	260	W•BF•-B-BMF	287
R3AASS-A	252	SANF•••	117	T2KS-•••PL	175	W•-BMF	286
R4FSS-A	252	SANF•••-PREM	118	T2KS-•••PM	175	W•DC-B	286
R4GSS-A	252	SANS•••	120	T31W-•••••PL	176	W•F•	287
R4HSS-A	252	SAP•••	433	T31W-•••••PM	176	W•F•-B	287
R4KSS-A	252	SBP•	128	T32W-•••••PL	176	W•F•-B-BMF	287
R4LSS-A	252	SC•••	61, 66	T32W-•••••PM	176	WA•	20
R4MSS-A	252	SC••X•AL	74	T-350	260	WA•B	20
RAM•	15, 18	SC••X•SS	74	T-50IX	260	WB•	20
RB•	344-345	SCCW•••	61	T7RWWW-•••••PL	175	WS•BF•	294
RB••	340	SCF••X•BR	346	T7RWWW-•••••PM	175	WS•BF•-BOP	296
RB•••EZ	28	SCM••X•BR	346	T7WWW-•••PL	175	WS•DC-A	294
RB•••EZA	28	SCV•••-BSP	414	T7WWW-•••PM	175	WS•F•	294
RBU•	344-345	SF••/BR	88	TBC•••	60	WS•F•-BOP	296
RC•••BL	30	SF••/SS	88	TCS•••	410	WS•F•-SS	294
RC•••EZ	30	SG•••	70	THN••	434	WS•F•-SS-BOP	296
RC•••EZCR	46	SHS••	411	TL14AM7-•••PL	176	WSR•	20
RC••EZ-••	30	SK••••	71	TL14AM7-•••PM	176	Y•••	412
RD•••	32	SM••/BR	88	TR•BF•	284		
RD•••DIN EZ	49	SM••/SS	88	TR•F•	284		
RD•••EZ	32	SN••	441	TSC••••	19		
RDA••••BL	45	SRH360CMP-G	182	TSK••	19		
RDA•••EZ	39	SRH360CMP-R	182	TSS••	411		
RDM•••	435	SRH360NPT-G	182	UL••••	72-73		
RDWBPST•••EZ	45	SRH360NPT-R	182	V•BF•	301		
RDWSP•••EZ	45	SS•••	70	V•BF•-B	301		
RE•••••••	34	ST••CS	437	V•BF•-B-E	303		
REBCB	428	ST•BF•	293	V•BF•-E	303		
REF•••B	428	ST•BF•-SS	293	V•BF•-SS	301		
RERE•••B	428	ST•DC-A	291	V•BF•-SS-E	303		
RESG	428	ST•F•	293	V•DC-A	301		
RGB•	340	ST•F•-SS	293	V•F•	301		
RGB••	340	ST•OF•	293	V•F•-B	301		
RGF••	339	ST•OF•-SS	293	V•F•-B-E	303		
RH•••BL	38	STB•••	433	V•F•-E	303		
RH•••EZ	39	STB••CS	437	V•F•-SS	301		
RHS•••	410	STBC•••	60	V•F•-SS-E	303		
RHSC•••	42	STC•••	432	V•M•	299		
RJT-•••••SP	143	STC••A	432	V•M•-B	299		
RJT-•••SP	143	STC-180-R•••	180	V•M•-B-E	303		
RLP••	343	STC-360-R•••	182	V•M•-E	303		
RMS•	342	STV•••	432	V•M•-SS	299		
RMS••	342	STV••CS	437	V•M•-SS-E	303		
RRHS••	410	SUBV•••	409	V•OF•	301		
RSS••	411	SV-CT•	225	VB•••SS	398		
RST••	433	SWCV•••	356	VEP•F•	285		

Numerical Part Number Index

In the following index, a • is used to represent a variable. Therefore, to find 6WBF4-B or 12WBF12-B look for •WBF•

Part No.	Page No.	•••AWBPSTAL	44	•••-DVR-AL	365	••DALB	31
156	345	•••AWBPSTSS	44	•••DWPSTAL	44	••DALN	31
187	345	•••AWSPAL	44	•••DWPSTSS	44	••DBRN	31
206	345	•••AWSPSS	44	•••DWSPAL	44	••DBRN	31
212	345	•••B-90-AL	40	•••DWSPSS	44	••DCAL	37
225	345	•••BALB	27	•••E-90-AL	41	••DCBR	37
250	345	•••BALN	27	•••EAL	33	••DCPP	37
306	345	•••BBRB	27	•••EBR	33	••DCSS	37
350	345	•••BBRN	27	•••-E-EC-AL	46	••DPAL	36
375	345	•••BPPB	27	•••EPP	33	••DPBR	36
401	345	•••BPPN	27	•••EPPDIN	49	••DPPB	31
418	345	•••BSSB	27	•••ESS	33	••DPPN	31
450	345	•••BSSN	27	•••ESSDIN	49	••DPPP	36
750	345	•••C-90-AL	40	•••F-90-AL	41	••DPSS	36
850	345	•••C-90-SS	40	•••FALB	35	••DSSB	31
860	96	•••CAL	29	•••FALN	35	••DSSDIN	49
96	394	•••-C-AL	29	•••FBRB	35	••DSSN	31
968	345	•••CBR	29	•••FBRN	35	••EAL	33
4530	363	•••-C-EC-AL	46	•••FPPB	35	••EBR	33
4540	363	•••CPP	29	•••FPPN	35	••EPP	33
••••-AA-AL	40	•••CPPDIN	49	•••FSSB	35	••ESS	33
••••-AA-BR	40	•••CSS	29	•••FSSN	35	••FALB	35
••••-AA-SS	40	•••CSSDIN	49	•••-G	54	••FALN	35
••••ASAFHT	436	•••-CVR-AL	365	•••GPCBU	368	••FBRB	35
••••-B-AL	27	•••D-90-AL	41	•••GPCTF	368	••FBRN	35
••••-DA-AL	39	•••D-90-SS	41	•••-HRP-BR	43	••FPPB	35
••••-DA-ALH	39	•••DA-90-AL	41	•••-HRP-SI	43	••FPPN	35
••••-DA-BR	39	•••DALB	31	•••-HRP-SP	43	••FSSB	35
••••-D-AL	31	•••DALN	31	•••-LH-BR	38	••FSSN	35
••••-DA-MI	39	•••DBRB	31	•••NP16SS	436	••-G	54
••••-DA-SS	39	•••DBRN	31	•••PRSCSS	43	••-G-BU	55
••••-D-BR	31	•••DCAL	37	•••10	137	••-G-EPR	55
••••DFHT	436	•••DCBR	37	••-•-400-99-BPKIT	359	••-G-HYP	55
••••-D-SS	31	•••-DC-L-AL	38	••AALB	26	••-G-NE	55
••••-E-AL	34	•••-DC-L-BR	38	••AALN	26	••-G-SIL	55
••••EFHT	436	•••-DC-L-SS	38	••APPB	26	••-G-TEV	56
••••-F-SS	35	•••DCSS	37	••APPN	26	••-G-TF	56
••••NP16FHT	436	•••DD-90-AL	41	••ASSB	26	••-G-TFACC	56
•••/•••	404	•••DFHTSS	436	••ASSN	26	••-G-TFEP	56
•••A-90-AL	40	•••-DL-AL	42	••BALB	27	••-G-TFVI	56
•••A-90-SS	40	•••-DL-SS	42	••BALN	27	••-G-TFWB	56
•••AALB	26	•••DPAL	36	••BBRB	27	••-G-THK	55
•••AALN	26	•••-DP-AL	392	••BBRN	27	••-G-VI	55
•••-AL-AL	42	•••DPBR	36	••BPPB	27	••-G-WB	55
•••-AL-SS	42	•••DPPB	31	••BPPN	27	••-G-WNE	55
•••APPB	26	•••DPPN	31	••BSSB	27	••/••• AL	396
•••APPN	26	•••DPPP	36	••BSSN	27	••-390-••••••	358-359
•••ASAFHTSS	436	•••DPSS	36	••CAL	29	••-390-209U	358
•••ASSB	26	•••-DP-SS	392	••CBR	29	••-390-828U501	358
•••ASSDIN	49	•••DSSB	31	••CPP	29	••-400-••••	357
•••ASSN	26	•••DSSN	31	••CSS	29	••-400-••••••	358-359

•AGDP	282	•-DU	91	•JM•-B	322	•VF•-SS-E	302
•AGF•	283	•EAF•	309	•JS•-B	322	•VM•	299
•AGF•-PS	283	•EBF•-B	307	•KBF•	281	•VM•-B	299
•AGF•-PV	283	•EBF•-S	307	•KDP	280	•VM•-B-E	302
•AGF•-PV-PS	283	•EF•-B	307	•KF•	281	•VM•-SS-E	302
•AGOF•-PV	283	•EF•-S	307	•KOF•	281	•VN•-SS	299
•BRBF•-B-7	319	•EM•-B	308	•N•N	10, 331	•VNM•-E	302
•BRF•-B-7	319	•EM•-S	308	•NBF•	7, 328	•WBF•-B	287
•BRGM•-B-7	320	•ES•-B	308	•NBM•	6, 327	•WBF•-B-HN	287
•BRM•-B-7	320	•FB•	322	•NCS•	6, 9, 327, 330	•WDP•-B	286
•BRS•-B-7	320	•FB•-B	318	•NF•	7, 328	•WSBF•	295
•CJBF•-B	324	•FBF•	321	•NF•-B	9, 330	•WSBF•-BOP	296
•CJBM•-B	325	•FBF•-B	315	•NM•	6, 327	•WSBF•-VP	295
•CJF•-B	324	•FBM•	316	•NM•-V	8, 329	•WSDP•-A	294
•CJGM•-S	325	•FBM•-B	316	•NS•	9, 330	•WSF•	295
•CJM•-B	325	•FE•-B	314	•N-SKIT	10, 331	•WSF•-BOP	296
•CJS•-B	326	•FF•	321	•NYN•	10, 331	•WSF•-SS	295
•CM•B•-B-E	310-311	•FF•-B	315	•PCS•	14, 335	•WSF•-SS-VP	295
•CM•B•-B	310-311	•FF•-S	315	•PDF•	297	•WSF•-VP	295
•CM•S•-B-E	310-311	•FH•-B	314	•PDM•	297	0•••	71
•CM•S•-B	310-311	•FK•-B	314	•PF•	12, 333	1•••	61
•CMB•-B	310-311	•FL•-B	314	•PM•	13, 334	10••••	67
•CMB•-B-E	310-311	•FM•	322	•PS•	13, 14, 334-335	101-H•••	166
•CMF•-B	310-311	•FM•-B	316	•P-SKIT	14, 335	101-HX•••	166
•CMF•-B-E	310-311	•FM•-S	316	•SASA	87	1125A	366
•CMS•-B	310-311	•FS•	318, 322	•SNP16	87	1143A	366
•CMS•-B-E	310-311	•FS•-B	318	•STBF•	292	13HBN-G•••IDF	151
•CVVBF•	305	•FS•-S	318	•STBF•-SS	292	13HBN-G•••RJT	143
•CVVF•	305	•HBF•	276	•STDP•-A	291	13H-G•••IDF	151
•DB•-B	317	•HBF•-B	276	•STF•	292	13H-G•••RJT	143
•DBF•-B	314	•HBF•-S	276	•STF•-SS	292	13MHMM•••	159, 177
•-DBHU•	91	•HBF•-SS	276	•STOF•	292	13MHMM-DP•••	159
•DBM•-B	316	•HDP	274	•STOF•-SS	292	13MHMM-Q•••	159
•-DCAP	93	•HDP•-A	275	•TBM•	304	13MHMM-R•••	177
•DE•-B	314	•HF•	276	•TDP	304	13MHP•••	159
•-DELU•	92	•HF•-B	276	•TF•	304	13RBN-G•••DIN	147
•DF•-B	314	•HF•-HV	275	•TM•	304	13RBN-G•••RJT	143
•DF•-S	314	•HF•-S	276	•TM•-SS	304	13RBN-G•••SMS	155
•-DFC•	91	•HF•-SS	276	•TRBF•	284	13R-G•••DIN	147
•-DFE•	92	•HOF•	276	•TRF•	284	13R-G•••SMS	155
•-DFPLUG	93	•HSF•-B	279	•VBF•	300	14A-R•••DIN	148
•DH•-B	314	•HSF•-S	279	•VBF•-B	300	14A-R•••DINM	148
•DH•-S	314	•HTBF•	289	•VBF•-B-E	302	14A-R•••IDF	152
•DK•-B	314	•HTDP	288	•VBF•-E	302	14A-R•••RJT	144
•DL•-B	314	•HTF•	289	•VBF•-SS	300	14A-R•••SMS	156
•DM•-B	316	•HTF•-SS	289	•VBF•-SS-E	302	14MPHR-R••••••	161
•DM•-S	316	•HTJB•	289	•VDP•-A	300	14R-R•••IDF	152
•-DMC•	90	•HTM•	289	•VEPF•	285	14R-R•••RJT	144
•-DME•	91	•HTOF•	289	•VEPOF•	285	14R-R•••SMS	156
•-DRATT•	92	•JB•-B	322	•VF•	300	14WMP-R•••	160
•DS•-B	317	•JBF•	321	•VF•-B	300	15A-R•••DIN	148
•-DTMT•	93	•JF•	321	•VF•-B-E	302	15A-R•••DINM	148
•-DTTM•	92	•JF•-B	321	•VF•-E	302	15A-R•••IDF	152
•-DTTT•	91	•JM•	322	•VF•-SS	300	15A-R•••RJT	144

15A-R•••SMS	156	300H-PADBR	38	40MP-SFY•••RJT	146	5000 ST	365
15R-R•••IDF	152	300PCALAP	367	40MP-SFY•••SMS	158	5000-••	362
15R-R•••RJT	144	3020••	355	40MPS-U•••	163	51•••	70
15R-R•••SMS	156	3030••	354	40MP-U•••IDF	154	5111A	95
16AMP-R•••	160	3090••	354	40MP-U•••RJT	146	5204•••	361
16AMP-R•••DIN	147	31440-225AL	363	40MP-U•••SMS	158	5300•	362
16AMP-R•••IDF	151	35••AA	356	40MP-U••MDIN	150	59-00•	412
16AMP-R•••SMS	155	35••CA	356	40MP-V••MDIN	150	69/•• PB	397
2•••	71	35••CC	356	40MP-X•••IDF	154	6-99-400BPKIT	359
2/•••-••• AL	394	4••	61	40MP-XW•••RJT	146	7/•-• AL	396
20••••	67	4••••	64	40MP-XW•••SMS	158	7/•••-••• AL	396
200YDAA-AL	42	4/•••-••• AL	395	41440-225AL	363	8502••	254
206-•-5	359	40018BN	364	41450-DCAL	362	8504••	254
2180B/15	352	400-206-65	359	42MP-E•••	163	8508••	254
2180V/15	352	400-G-BU	364	42MP-G•••	163, 177	855•	95
2182B/XX	352	4040••	355	42MP-GR•••	166	856-•	95
2182F/XX	353	40MP-E•••IDF	154	42MP-GRE•••	166	861-••	96
2182V/XX	353	40MP-E•••RJT	146	42MP-SFY•••	162	9•••	71
2500HB0000	243	40MP-E•••SMS	158	42MP-U•••	162	90PPA•••	40
2JE2-B	323	40MP-E••MDIN	150	42MP-UW•••	163	90PPC•••	40
2JH2-B	323	40MPF-E•••	164	450•	363	90PPD•••	41
2JK3-B	323	40MPF-SFY•••	165	450•ASSM	363	90PPF•••	41
2JL3-B	323	40MPF-U•••	164	5••	61		
3•••	71	40MPF-UW•••	164	5000 AI	365		
3/•••-••• AL	395	40MPF-XC•••	165	5000 AIR	365		
3000••	354	40MPF-XW•••	165	5000 AIS	365		
3000TE••	355	40MP-S••MDIN	150	5000 AIV	365		
3001•••	355	40MP-SFY•••IDF	154	5000 S	365		





A	Air Fittings	<i>page</i> 4
B	Cam & Groove	<i>page</i> 22
C	Clamps & Accessories	<i>page</i> 58
D	Fire Products - Dixon Powhatan	<i>page</i> 76
E	Fittings, Gauges & Adapters	<i>page</i> 80
F	Hose & Hose Assemblies	<i>page</i> 100
G	Hygienic Products	<i>page</i> 138
H	Permanently Attached Couplings - Holedall®	<i>page</i> 238
I	Quick Release Couplings	<i>page</i> 268
J	Steam Couplings - Boss™	<i>page</i> 336
K	Tanker, Overfill & Storage Tank Products	<i>page</i> 348
L	Valves - General & Industrial	<i>page</i> 402
M	Water Couplings	<i>page</i> 416
N	Technical & Safety Information	<i>page</i> 442

Dixon Europe

Dixon Deutschland GmbH
Godesberger Strasse 20b
D – 53842 Troisdorf – Spich
Germany
Tel: +49 (0)2241 844 060
Email: info@dixon-deutschland.de

Dixon Russia
22/2 A Sadovaya Street
Office 27-H
Saint Petersburg
Russia
Tel: +7 (812) 448-83-67
Email: info@dixonrussia.ru

Dixon Middle East
Executive Suite,
PO Box 121599,
Saif Zone-Sharjah,
United Arab Emirates
Email: enquiries@dixonme.com

Dixon France
105 Route Pommiers
UBIDOCA Center, 5837
F-74370 Saint Martin Bellevue
France
Email: enquiries@dixoneurope.eu

Dixon Worldwide

Dixon Valve & Coupling Co
800 High Street
Chestertown
MD 21620
USA
Tel: +1 410 778 2000
Email: sales@dixonvalve.com

Dixon Shanghai
Room 801-803
No.3553 North Zhongshan Rd
Putuo District
Shanghai, China
Tel: +86 21 6173 7998
Email: enquiries@dixonvalve.com.cn

Dixon Asia Pacific
PO Box 2491
Regency Park
SA 5942
Australia
Tel: +61 8 8202 6000
Email: enquiries@dixonvalve.com.au

Dixon India
90, Virwani Industrial Estate,
Western Express Highway,
Goregaon East,
Mumbai – 400 063, India
Tel - +91-22-61949494 / 29271152
Email: salesindia@dixonvalve.com.au



The Right Connection™

Dixon Group Europe Limited



Dixon House, 350 Leach Place,
Walton Summit Centre, Preston PR5 8AS, UK.

Telephone: +44 (0)1772 323 529

Fax: +44 (0)1772 314 664

Email: enquiries@dixoneurope.co.uk

www.dixoneurope.co.uk / www.dixoneurope.eu

Stay connected with Dixon on  or 
www.youtube.com/user/DixonValve



Customer Service:
+44 (0)1772 323 529