

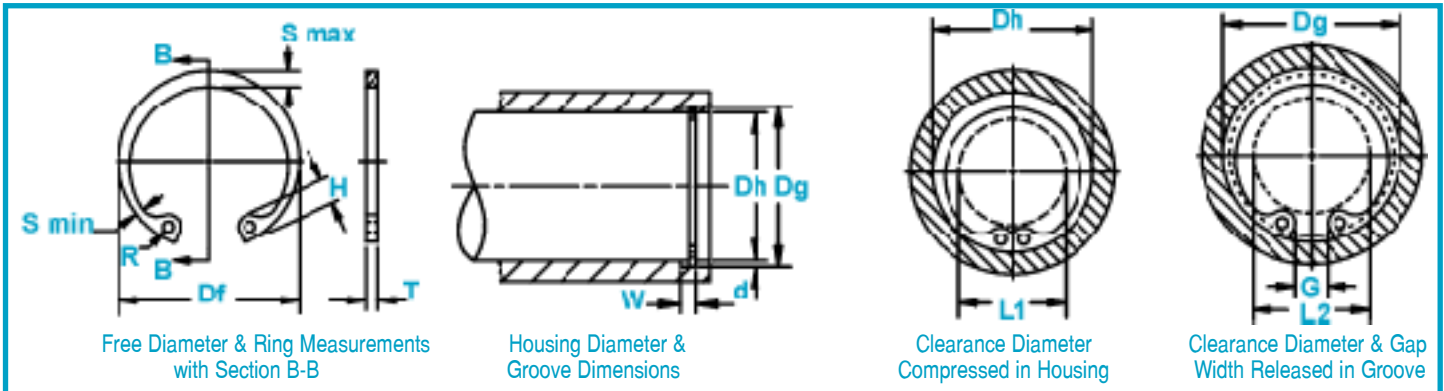

# HO Housing Rings

## Axially Assembled, Internal

Once installed in the groove of a housing/bore, the shoulder holds an assembly in place.



RING NO.	HOUSING			GROOVE SIZE			RING SIZE & WEIGHT					CLEARANCE DIA.		THRUST LD. (lbs.) Sqr. corner abutment			
	DIAMETER			DIAMETER	WIDTH	DEPTH	Free Diameter	Thickness***		Wght. Per 1000 Pcs.	Compressed in housing	Released in groove	Ring Safety Factor of 4	Groove Safety Factor of 2			
	Dh DEC	Dh FRAC	Dh mm					Dg	Tol.						W	Tol.	d
HO-175	1.750	1-3/4	44.4	1.858	±.005	.068	+.004	.054	1.942	+.035	.062		10.3	1.26	1.36	15580	8050
HO-181	1.812	1-13/16	46.0	1.922	.005*	.068	-.000	.055	2.012	-.025	.062		11.5	1.34	1.38	16139	8450
HO-185	1.850	-	47.0	1.962		.068		.056	2.054		.062		12.8	1.35	1.46	16443	8750
HO-187	1.875	1-7/8	47.6	1.989		.068		.057	2.072		.062		12.8	1.37	1.48	16697	9050
HO-193	1.938	1-15/16	49.2	2.056		.068		.059	2.141		.062		13.3	1.46	1.58	17255	9700
HO-200	2.000	2	50.8	2.122		.068		.061	2.210		.062		14.0	1.52	1.64	17763	10300
HO-206	2.047	-	52.0	2.171		.086		.062	2.280		.078		18.0	1.52	1.64	23091	10850
HO-206	2.062	2-1/16	52.4	2.186		.086		.062	2.280		.078		18.0	1.54	1.66	23091	10850
HO-212	2.125	2-1/8	54.0	2.251		.086		.063	2.350		.078		19.4	1.58	1.70	23751	11350
HO-218	2.165	-	55.0	2.295		.086		.065	2.415		.078		19.6	1.63	1.75	24461	12050
HO-218	2.188	2-3/16	55.6	2.318		.086		.065	2.415		.078		19.6	1.66	1.79	24461	12050
HO-225	2.250	2-1/4	57.1	2.382		.086		.066	2.490		.078		21.8	1.67	1.80	25223	12600
HO-231	2.312	2-5/16	58.7	2.450		.086		.069	2.560		.078		22.6	1.73	1.93	25832	13550
HO-237	2.375	2-3/8	60.3	2.517		.086		.071	2.630		.078		23.2	1.79	1.86	26542	14300
HO-244	2.440	2-7/16	62.0	2.584		.086		.072	2.702	+.040	.078	±.003	25.4	1.86	2.00	27304	14900
HO-250	2.500	2-1/2	63.5	2.648		.086		.074	2.775	-.030	.078		25.5	1.91	2.05	28014	15650
HO-250	2.531	2-17/32	64.3	2.681		.086		.075	2.775		.078		25.5	1.94	2.09	28014	15650
HO-256	2.562	2-9/16	65.1	2.714		.103		.076	2.844		.093		34.0	1.93	2.08	34206	16500
HO-262	2.625	2-5/8	66.7	2.781	±.006	.103	+.005	.078	2.910		.093		34.5	2.02	2.17	35068	17350
HO-268	2.677	-	68.0	2.837	.006*	.103	-.000	.080	2.980		.093		35.0	2.05	2.21	35931	18250
HO-268	2.688	2-11/16	68.3	2.848		.103		.080	2.980		.093		35.0	2.06	2.22	35931	18250
HO-275	2.750	2-3/4	69.8	2.914		.103		.082	3.050		.093		35.5	2.12	2.28	36642	19200
HO-281	2.812	2-13/16	71.4	2.980		.103		.084	3.121		.093		36.0	2.18	2.34	37504	20050
HO-281	2.835	-	72.0	3.006		.103		.085	3.121		.093		36.0	2.21	2.38	37504	20050
HO-287	2.875	2-7/8	73.0	3.051		.103		.088	3.191		.093		41.0	2.24	2.41	38367	21500
HO-300	2.953	-	75.0	3.135		.103		.091	3.325		.093		42.5	2.32	2.50	40093	23150
HO-300	3.000	3	76.2	3.182		.103		.091	3.325		.093		42.5	2.37	2.55	40093	23150
HO-306	3.062	3-1/16	77.8	3.248		.120		.093	3.418		.109		53.0	2.41	2.59	47807	24100
HO-312	3.125	3-1/8	79.4	3.315		.120		.095	3.488		.109		56.0	2.47	2.66	48822	25200
HO-315	3.149	-	80.0	3.341		.120		.096	3.523		.109		57.0	2.49	2.68	49329	25700
HO-315	3.156	3-5/32	80.2	3.348		.120		.096	3.523	±.055	.109		57.0	2.50	2.69	49329	25700
HO-325	3.250	3-1/4	82.5	3.446		.120		.098	3.623		.109		60.0	2.54	2.73	50750	27000
HO-334	3.346	3-11/32	85.0	3.546		.120		.100	3.734		.109		65.0	2.63	2.83	52374	28300
HO-347	3.469	3-15/32	88.1	3.675		.120		.103	3.857		.109		69.0	2.76	2.96	54201	30200
HO-350	3.500	3-1/2	88.9	3.710		.120		.105	3.890		.109		71.0	2.79	3.00	54709	31200

\* F.I.M. (FULL INDICATOR MOVEMENT)- MAXIMUM ALLOWABLE DEVIATION OF CONCENTRICITY BETWEEN GROOVE & HOUSING.

† BASED ON HOUSINGS/SHAFTS MADE OF COLD ROLLED STEEL. FOR AN EXPLANATION OF FORMULAS USED TO DERIVE THRUST LOAD AND OTHER PERFORMANCE DATA CONTACT THE ROTOR CLIP ENGINEERING DEPARTMENT.

\*\*\*FOR PLATED RINGS ADD .002" TO THE LISTED MAXIMUM THICKNESS. MAXIMUM THICKNESS WILL BE A MINIMUM OF .0002" LESS THAN THE LISTED GROOVE WIDTH (W) MINIMUM.

For technical assistance call **1-800-55-ROTOR**

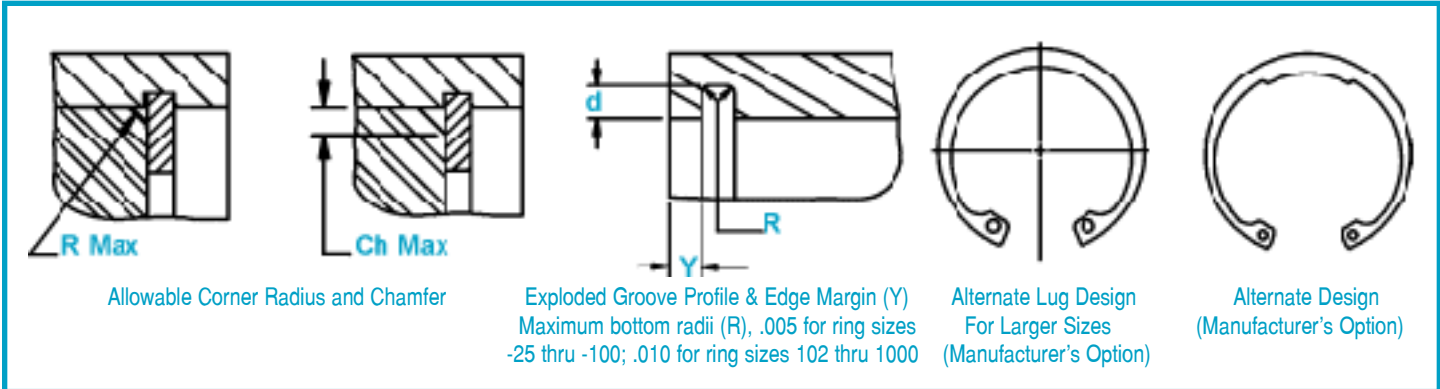

RING NO.	LUG HEIGHT		MAXIMUM SECTION		MINIMUM SECTION		HOLE DIAMETER		GAP IDTH Ring in Groove	ALLOWABLE CORNER RADII & CHAMFERS			MAX. LOAD w/ R max or Ch max (lbs.)	EDGE MARGIN
	H	Tol.	S max	Tol.	S min	Tol.	R	Tol.		G Min	R max	Ch max		
HO-175	.230		.170		.083		.078		.372	.064	.050	3900	.162	
HO-181	.230		.170		.084		.093		.382	.064	.050	3900	.165	
HO-185	.234		.170		.085		.093		.360	.064	.050	3900	.168	
HO-187	.234		.170		.085		.093		.430	.064	.050	3900	.171	
HO-193	.230		.170		.085		.093		.438	.064	.050	3900	.177	
HO-200	.230		.170		.085		.093		.453	.064	.050	3900	.183	
HO-206	.250		.186		.091		.093		.428	.078	.061	6200	.186	
HO-206	.250	±.005	.186	±.007	.091	±.007	.093	+ .015	.468	.078	.062	6200	.186	
HO-212	.250		.195		.096		.093	-.002	.460	.078	.062	6200	.189	
HO-218	.250		.199		.098		.093		.439	.078	.062	6200	.195	
HO-218	.250		.199		.098		.093		.489	.078	.062	6200	.195	
HO-225	.280		.203		.099		.093		.478	.078	.062	6200	.198	
HO-231	.280		.206		.100		.093		.486	.078	.062	6200	.207	
HO-237	.280		.207		.102		.093		.504	.078	.062	6200	.213	
HO-244	.280		.209		.103		.110		.518	.078	.062	6200	.216	
HO-250	.280		.210		.103		.110		.532	.078	.062	6200	.222	
HO-250	.280		.210		.103		.110		.597	.078	.062	6200	.225	
HO-256	.300		.222		.109		.110		.540	.088	.070	9000	.228	
HO-262	.290		.226		.111		.110		.558	.088	.070	9000	.234	
HO-268	.300		.230		.113		.110		.539	.090	.072	9000	.240	
HO-268	.300		.230		.113		.110		.568	.090	.072	9000	.240	
HO-275	.300		.234		.115		.110		.590	.092	.074	9000	.246	
HO-281	.300		.230		.115		.110		.615	.088	.070	9000	.252	
HO-281	.300		.230		.115		.110		.676	.088	.070	9000	.255	
HO-287	.300		.240		.120		.110		.626	.092	.074	9000	.264	
HO-300	.300		.250		.122		.110		.619	.092	.074	9000	.273	
HO-300	.300		.250		.122		.110		.738	.092	.074	9000	.273	
HO-306	.310		.254		.126		.125		.651	.097	.078	12000	.279	
HO-312	.310		.259		.129		.125		.655	.099	.079	12000	.285	
HO-315	.310		.262		.129		.125		.650	.100	.080	12000	.288	
HO-315	.310		.262		.129		.125		.669	.100	.080	12000	.288	
HO-325	.342		.269		.135		.125		.698	.104	.083	12000	.294	
HO-334	.342	±.008	.276	±.008	.140	±.008	.125		.705	.108	.086	12000	.300	
HO-347	.342		.286		.144		.125		.763	.108	.086	12000	.309	
HO-350	.342		.289		.142		.125		.774	.110	.088	12000	.315	

FOR HARDNESS SPECIFICATIONS, SEE END OF THIS SECTION