

ACAT

SPEED WITHIN REACH

UNIPUNCH

CATALOG AND PARTS BOOK



MAKE YOUR PARTS **FASTER** FOR LESS

TABLE OF CONTENTS

Introduction and Mounting Systems		B Series		Technical Data	
How to Order or Request a Quote	1	B Series Lineup	53-54	Common Shapes and Angular Orientation	91
How to Use this Catalog	2-3	BX-3/4"	55	Custom Shapes and Applications	92
Overview of UniPunch Modular Tooling	4-5	B-1 1/4"	57	Forming Tools	93
Mounting Method Overview	6-7	B-1 3/4"	58	Tonnage Information	94
Straight Line Punching Method	8	BX-2 1/4"	59	Drill Sizes and Bend Allowance Formulas	95
Fast Changeover Method	9	B-3"	60	Decimal Equivalent Chart	96
Creating Prototypes Method	10	B-5"	61	Die Clearance Guidelines	97
Mounting: The Basic Steps	11	Corner Notch Units	62	Material Specifications	98
Bed Rails and Template Mounting Plate	12	7180 Corner Notch Unit	63	Metal Gauge Data	99
Unispacers, Keyed Mounting Templates, and Ram Plates	13			Holder Slot Sizes and Locations	100-101
T-Slotted Plates and Universal Base Plates	14				
Mounting Accessories	15-18	5300 Flat Stock Cutoff Units	66		
		4000 Radius Unit	67		
A Series		G Series		Replacement Tooling	
A Series Lineup	19-21	G Series Lineup	68	Unitool Replacement Tooling	102-113
A-1"	22	G Series Mounting Method	69		
A-1 1/4"	23	G-3/4" Triple Spring	70		
A-1 1/2"	24			General Information	
A-2"	25			Glossary	114
A-2 1/2"	26			Terms and Conditions	115-116
A-3 1/2"	27			Index	Inside Back Cover
A-5 1/2"	28				
A-8"	29	AE Series			
AJ-1"	30	AE Channel Punching	72		
AJ-1 1/4"	31				
AJ-1 1/2"	32	TP Series			
AJ-2"	33	TP Series Lineup	73		
AJ-2 1/2"	34	TP-1 1/4"	74		
FCU Feed Clearance Units	35	TP-2 3/8"	75		
AH-2 1/2"	36	TP-2"	76		
AH-3"	37	Mandrel Tube Punching	77		
AH-3 1/2"	38	TP-2M	78		
AH-6"	39	TP-AE	79		
OA-6"	40	TP-CN	80		
AD-4"	41				
AJD-2" Stainless Steel Punching	42				
AHD-2 1/2" Stainless Steel Punching	43	HZ Series			
AHD-3" Stainless Steel Punching	44	HZ Series Lineup and HZ-3/4"	81		
AHD-3 1/2" Stainless Steel Punching	45	HZ-1 1/4", HZ-1 1/2" & HZ-2"	82		
Corner Notch Units	48	Additional Products			
		Fitted Strippers and Guides	83		
		Tonnage Reduction	84		
		Upper Arm Kits	85		
		A-Series Stock Size Punches	86		
		Custom UniPunch Units	88		
		Punch & Die Sharpener	89		
		Tool Maintenance	90		

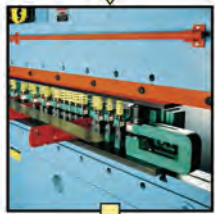

How to Order or Request a Quote



SOCIO COMERCIAL EN MÉXICO

Oficina Matriz

Av. Regio Parque #200, Regio Parque Industrial,
Apodaca N.L. C.P. 66633



www.acatmexicana.com



acat@acatmexicana.com



TEL. 81 8354 8910

MINIMUM REQUIRED INFORMATION

- Part number or model number
- Quantity
- Type and thickness of material being punched
- For round tooling, specify punch size
- For standard shaped tooling, specify hole shape, dimensions and orientation
- For custom applications, send us a drawing or sketch.



For UniPunch Products, Inc. Terms and Conditions of Sale, see pages 115 & 116

OPTIONAL FEATURES

Angular Orientation of shaped punches and dies: Page 91

Heeled Punches: Page 92

Typically used for edge notching.

Chisel Shear on Punches: Page 94

To reduce tonnage requirements.

Back Taper on Punches: Page 99

To help reduce stripping problems.

Stub Tip on Punches: Page 99

Designed to reduce punch tip breakage.

Radius Corners: Page 99

Potentially improves tooling life.

Alternative Tool Steels: Contact UniPunch

For tough materials that are difficult to punch.

Punch Coating, for example TiN Coating (Titanium Nitride): Contact UniPunch

To increase punch life.

Negative Die Taper:

Potentially reduces slug pulling.

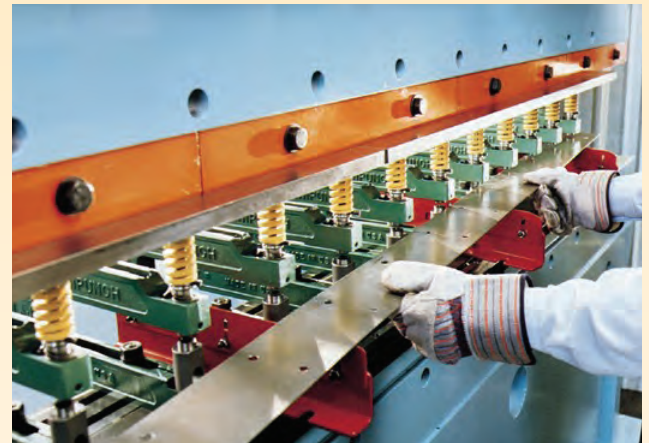

Copyright © 1998, 2000, 2003, 2006, 2014 UniPunch Products, Inc.

WARNING When UniPunch tooling is used in presses or press brakes, the point of operation (die space) must be guarded. O.S.H.A. requires that the employer must provide point-of-operation protection for the press operator. The use of loose blocks, loose shims or other unsecured material on top of punch heads or striker plates on UniPunch tooling is strictly prohibited. This practice is dangerous and serious operator injury can result.

How To Use This Catalog — A Typical Page

This catalog is designed for quick reference and easy accessibility to UniPunch product systems. Most pages are standardized to follow the general format shown below.

UniPunch product specialists can help you solve almost any application need. For standard and custom tooling application assistance, call 1-800-828-7061 (in the US) or 715-263-3900

Specifications & operating instructions

SPECIFICATIONS & OPERATING INSTRUCTIONS

OPERATING SHUT HEIGHT:	8-3/8" (212.7mm)	MIN. DIE CLEARANCE:	.006" (.15mm)
MIN. SHUT HEIGHT:	8-3/16" (208.0mm)	MAX. PUNCH DIAMETER:	.4375" (11.11mm)
UNIT OPEN HEIGHT:	9-1/8" (231.8mm)	MIN. PUNCH DIAMETER:	.0937" (2.38mm)
DIE HEIGHT:	3-1/2" (88.9mm)	MAX. SQUARE:	.309" (7.85mm)
MATERIAL FEED CLEARANCE:	7/16" (11.1mm)	MIN. SHAPE DIMENSION:	.0937" (2.38mm)
MAX. MATERIAL THICKNESS (MILD STEEL):	1/4" (6.4mm)	MAX. MATERIAL THICKNESS (STAINLESS STEEL):	1/8" (3.18mm)

AJ-1 1/4"
31.8mm width

Series & size

Model/Part No.

	ROUND UNITS		SHAPED UNITS		COMMON DIMS.		
	Model No.	Part No.	Model No.	Part No.	Throat Depth	Length A	Shipping Weight
BASE UNITS LESS PUNCH, DIE AND DIE ADAPTER	4AJ-1 1/4-LPD	14100-LPD	4SAJ-1 1/4-LPD	14105-LPD	4"	7"	9 lbs.
	8AJ-1 1/4-LPD	14101-LPD	8SAJ-1 1/4-LPD	14106-LPD	8"	11"	10.5 lbs.
	12AJ-1 1/4-LPD	14102-LPD	12SAJ-1 1/4-LPD	14107-LPD	12"	15"	15 lbs.
BASE UNITS WITH DIE ADAPTER (Includes Die Adapter)	4AJ-1 1/4-A-LPD	14100A-LPD	4SAJ-1 1/4-A-LPD	14105A-LPD	4"	7"	9.5 lbs.
	8AJ-1 1/4-A-LPD	14101A-LPD	8SAJ-1 1/4-A-LPD	14106A-LPD	8"	11"	11.0 lbs.
	12AJ-1 1/4-A-LPD	14102A-LPD	12SAJ-1 1/4-A-LPD	14107A-LPD	12"	15"	16.5 lbs.
COMPLETE UNITS WITH DIE ADAPTER (Includes Punch & Die)	4AJ-1 1/4-A	14100A	4SAJ-1 1/4-A	14105A	4"	7"	10 lbs.
	8AJ-1 1/4-A	14101A	8SAJ-1 1/4-A	14106A	8"	11"	11.5 lbs.
	12AJ-1 1/4-A	14102A	12SAJ-1 1/4-A	14107A	12"	15"	16 lbs.
COMPLETE UNITS WITH PEDESTAL DIE (Includes Punch)	4AJ-1 1/4-P	14100P	4SAJ-1 1/4-P	14105P	4"	7"	10 lbs.
	8AJ-1 1/4-P	14101P	8SAJ-1 1/4-P	14106P	8"	11"	11.5 lbs.
	12AJ-1 1/4-P	14102P	12SAJ-1 1/4-P	14107P	12"	15"	16 lbs.

KITS AND SHIMS

Shaped hole conversion kit:	7122
Key kit:	9322
Hardware kit:	9377
Punch shim:	N.A.
Pedestal/Adapter Die shim:	1117-12 1117-4B 1/16" thk./3 max.
Upper arm kit:	9733 Round 9734 Shaped

Kits, shims & notes.
See detail at right.

Component expanded view of unit internal parts, and part numbers

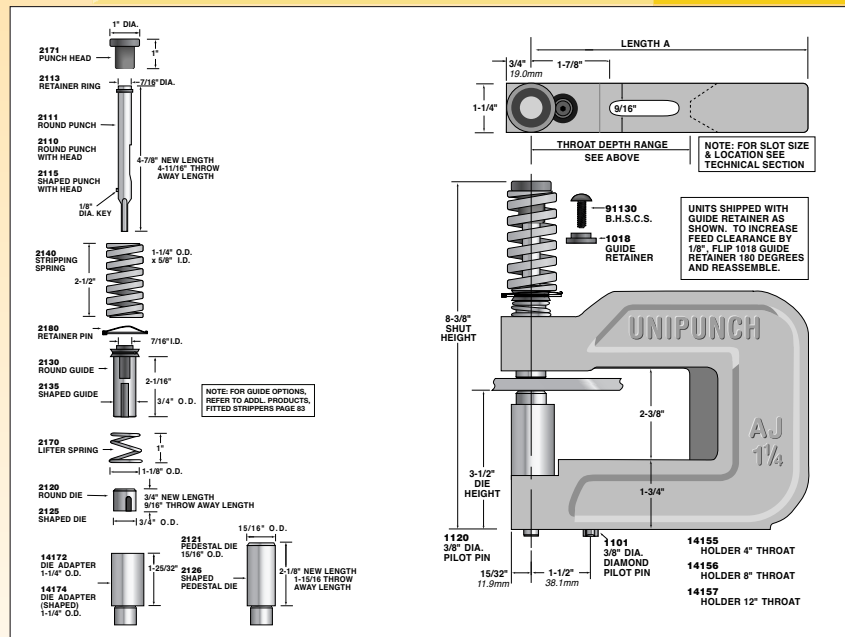

Ph: (800) 828-7061 • (715) 263-3900 • Email: info@unipunch.com • Web: www.unipunch.com

SPEED WITHIN REACH
UNIPUNCH

How To Use This Catalog — A Typical Page (Continued)

	ROUND UNITS		*SHAPED UNITS		COMMON DIMS.		
	Model No.	Part No.	Model No.	Part No.	Throat Depth	Length A	Shipping Weight
BASE UNITS LESS PUNCH, DIE AND DIE ADAPTER	4AJ-1¼P-LPD	14100P-LPD	4SAJ-1¼P-LPD	14105P-LPD	4"	7"	9 lbs.
	8AJ-1¼P-LPD	14101P-LPD	8SAJ-1¼P-LPD	14106P-LPD	8"	11"	10.5 lbs.
	12AJ-1¼P-LPD	14102P-LPD	12SAJ-1¼P-LPD	14107P-LPD	12"	15"	15 lbs.
BASE UNITS LESS PUNCH & DIE (Includes Die Adapter)	4AJ-1¼A-LPD	14100A-LPD	4SAJ-1¼A-LPD	14105A-LPD	4"	7"	9.5 lbs.
	8AJ-1¼A-LPD	14101A-LPD	8SAJ-1¼A-LPD	14106A-LPD	8"	11"	11.0 lbs.
	12AJ-1¼A-LPD	14102A-LPD	12SAJ-1¼A-LPD	14107A-LPD	12"	15"	16.5 lbs.
COMPLETE UNITS WITH DIE ADAPTER (Includes Punch & Die)	4AJ-1¼A	14100A	4SAJ-1¼A	14105A	4"	7"	10 lbs.
	8AJ-1¼A	14101A	8SAJ-1¼A	14106A	8"	11"	11.5 lbs.
	12AJ-1¼A	14102A	12SAJ-1¼A	14107A	12"	15"	16 lbs.
COMPLETE UNITS WITH PEDESTAL DIE (Includes Punch)	4AJ-1¼P	14100P	4SAJ-1¼P	14105P	4"	7"	10 lbs.
	8AJ-1¼P	14101P	8SAJ-1¼P	14106P	8"	11"	11.5 lbs.
	12AJ-1¼P	14102P	12SAJ-1¼P	14107P	12"	15"	16 lbs.

*To order shaped unit w/ round punch & die, add suffix *-RPD*.

UNIT ORDERING OPTIONS

The type highlighted in this example represents different options for ordering a punching unit, abbreviated as shown below. (Different units offer different ordering options—the example shown here just happens to have five.)

LPD Base Unit with Die Adapter (Less Punch and Die)

A Complete Unit with Die Adapter (Includes Punch and Die)

P Complete Unit with Pedestal Die (Includes Punch)

RPD Complete Shaped Unit with Round Punch & Die

Note: Contact UniPunch Sales for other options

SHAPED HOLE CONVERSION KITS

To convert a round hole unit into a unit for punching shaped holes, you would select Shaped Hole Conversion Kit 7122. This consists of:

2135 SHAPED GUIDE

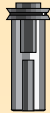

9322 KEY KIT

- 1088-3 GUIDE KEY
- 91312 SOCKET SET SCREW
- 1101 DIAMOND PILOT PIN
- 1088-8 ADAPTER DIE KEY
- 91310 SOCKET SET SCREW
- 1019 HOLDER TO ADAPTER KEY ..
- 91332 SOCKET SET SCREW

KIT PARTS CONFIGURATION

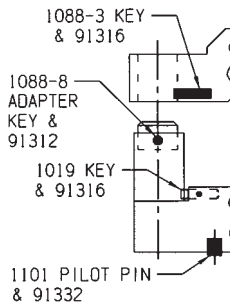

Shaped Die Options

For certain AJ units you have the option to purchase either a shaped die adapter and shaped die or the optional pedestal die. For example, order the 2125 shaped die and 14174 shaped die adapter or the optional 2126 shaped pedestal die in the AJ-1¼ Unit.

2125 SHAPED DIE



+

14174 SHAPED DIE ADAPTER



OR

2126 SHAPED PEDESTAL DIE



HARDWARE KITS

Hardware kits consist of fasteners, retainers, etc. for specific units. For example for the AJ-1¼ you would order:

9377 HARDWARE KIT

- 91130 B.H.S.C.S. 1/4 - 20 x 3/4
- 1018 GUIDE RETAINER
- 91312 SOCKET SET SCREW #10 - x 1/4
- 91601 1/4" LOCKWASHER

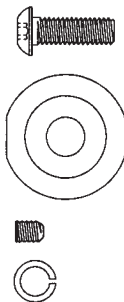

KIT PARTS CONFIGURATION

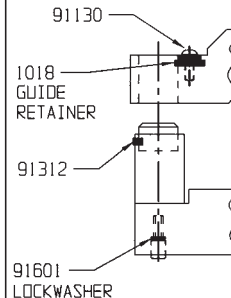

Turn your press brake or punch press into a hole punching profit center.

UniPunch Modular Tooling

- ✓ Works with existing presses
- ✓ Multiple holes and notches with one stroke
- ✓ Short lead time for ordering
- ✓ Fast changeover at the press
- ✓ Perfect for recurring jobs
- ✓ Low investment
- ✓ Precision held tolerances
- ✓ Reusable for different parts



Start with our tooling.

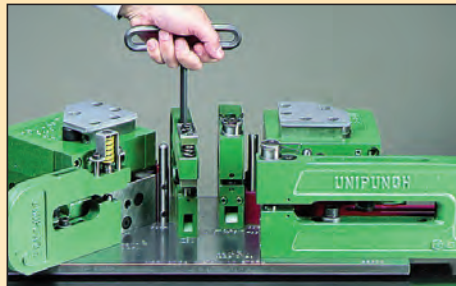

Mount it.



Install it in your press or stand alone system.

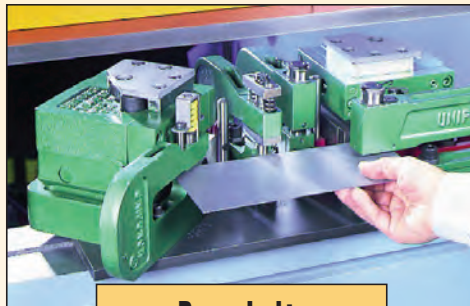

Punch it.

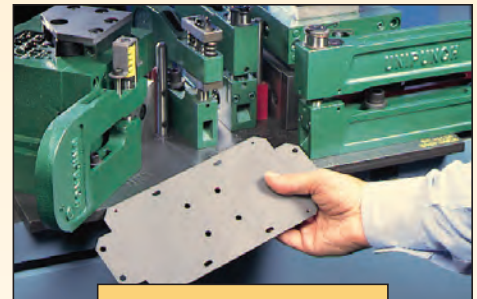

Profit.

Use UniPunch Modular Tooling for multiple holes with each stroke of the press.

The UniPunch System

- Dependable tooling for today's short run, quick changeover environment
- Combinations of tooling and gauging accessories are easily set up
- Punch or notch material up to 3/4" thick

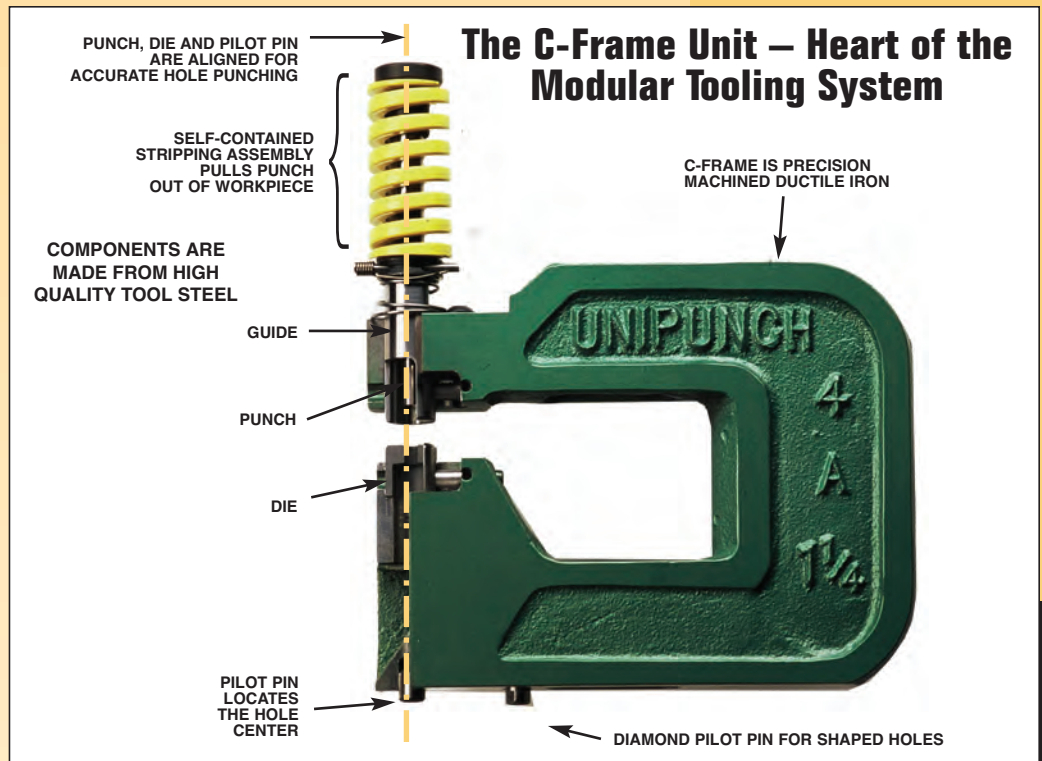

MOUNTING

UniPunch Modular Tooling: the solution for a variety of applications

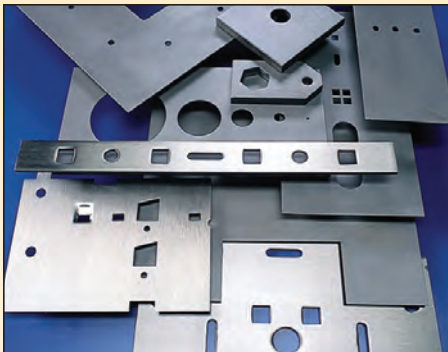

Hole Punching & Notching Flat Parts



Aluminum Extrusions



Brake Formed / Roll Formed Parts



Angles, Channels & Structural Parts



Tube Punching – Round or Square Tubing



Other Parts

Mounting Methods

Match the method to your press and shop requirements

UniPunch provides several methods for mounting modular tooling in your press, press brake or single station system. The method you select will depend on your shop environment.

Using dedicated setups, the UniPunch system is perfectly aligned with lean manufacturing with fast changeover at the press for producing small (and/or large) lots quickly each time you need that part.

Straight Line Punching

Press Brakes
Only

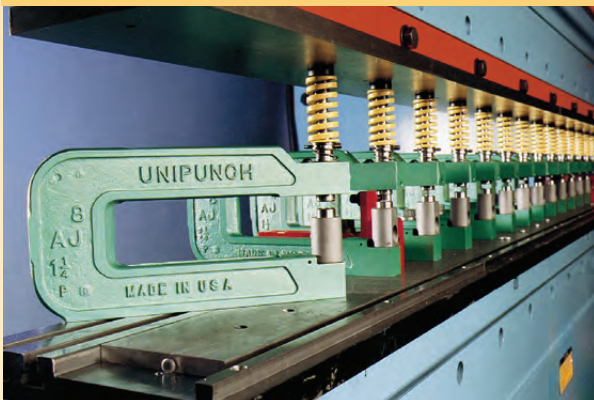

BED RAIL / STRIP TEMPLATE UNDER UNIT METHOD

- For straight line punching
- For the edge of sheets, angle iron and extrusions

Page 8

Fast Changeover from part to part

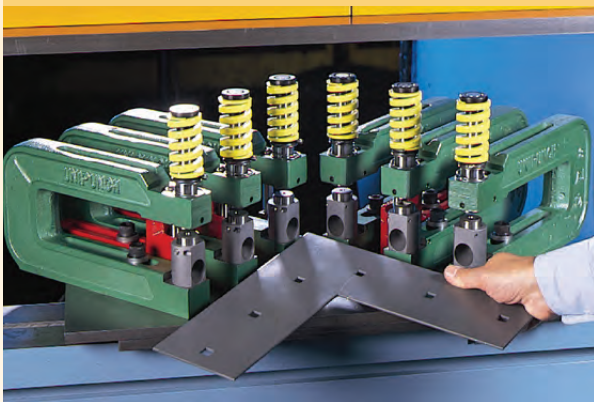

For Presses & Press Brakes

MOUNTING TEMPLATE METHOD

- Most popular method for all material thicknesses
- Makes identical parts consistently
- Allows units to be mounted outside the press for faster set up and tooling changeover
- Keyed, non-keyed and dovetail style templates are available

Page 9

Creating Prototypes

Press Brakes
Only

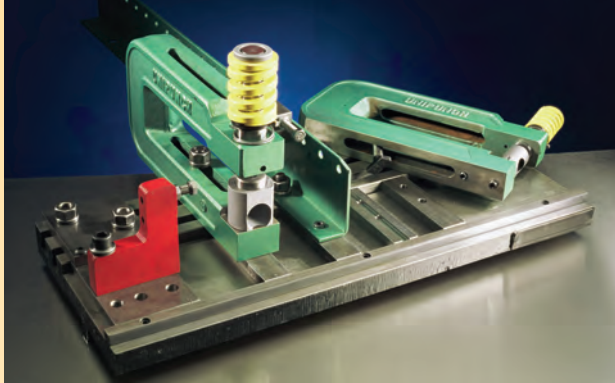

BED RAIL / UNISPACER METHOD

- For prototypes or short runs
- Straight line punching applications
- Unispacers are easily adjusted to accommodate varying hole patterns and part lengths

Page 10

All - Purpose

For Presses &
Press Brakes

UniPunch can also provide the following equipment to accommodate your press type and mounting method.

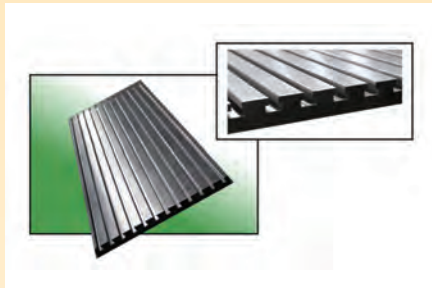

T-SLOTTED PLATES

in standard widths from 12" to 30"

Page 14

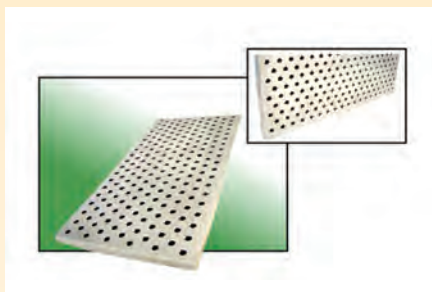

UNIVERSAL BASE PLATES with a uniform pattern of 1/2"-13 tapped holes

Page 14

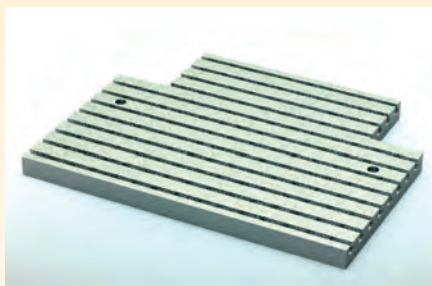

CUSTOM BED RAILS AND T-SLOTTED PLATES manufactured to your specifications

Contact the UniPunch Sales Department

Straight Line Punching In Press Brakes

The Strip Template in a Bed Rail is a solution for locating units for punching many holes in a row in flat metal, extrusions and structural shapes. A Strip Template measures $\frac{1}{2}$ " x $4\frac{1}{2}$ " and is long enough for your part. This fits into the recess in the Bed Rail. Hole-to-hole accuracy is maintained by the precision machined Strip Template. The pilot pin in the base of each unit assures accurate positioning of the holes in the part to be punched.

Note: To achieve straight line punching and fast changeover at your press brake, use a dedicated setup on a keyed template. **See page 9**
To achieve straight line punching and prototyping, consider using Unispacers. **See page 10**

BED RAIL / STRIP TEMPLATE UNDER UNIT METHOD

- For straight line punching the edge of sheets, angle iron and extrusions.
- Strip Template, $\frac{1}{2}$ " (12.7mm) x $4\frac{1}{2}$ " (114.3mm) x specific length, fits into bed rail recess.
- The pilot pin in the base of each unit assures accurate positioning of holes in the part to be punched.
- Part print tolerance accuracy expected is **.005" (.13mm)**.

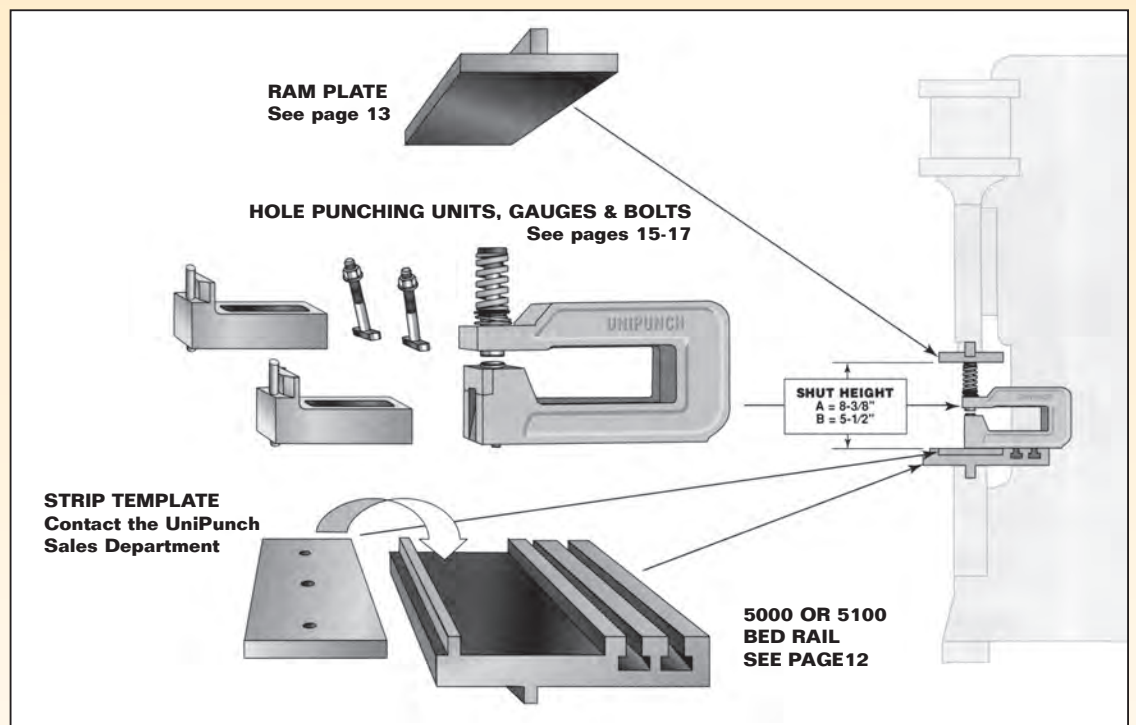

Faster Changeover from part to part Presses & Press Brakes

Dedicated setups are ready when you are. A dedicated setup is a combination of UniPunch press tooling assigned to a specific part, pre-assembled onto a template and ready for quick installation into a press. The UniPunch tooling is assigned to the part for the life of the part. If the part is no longer required, the tooling can be disassembled and rededicated in a new setup for a different part.

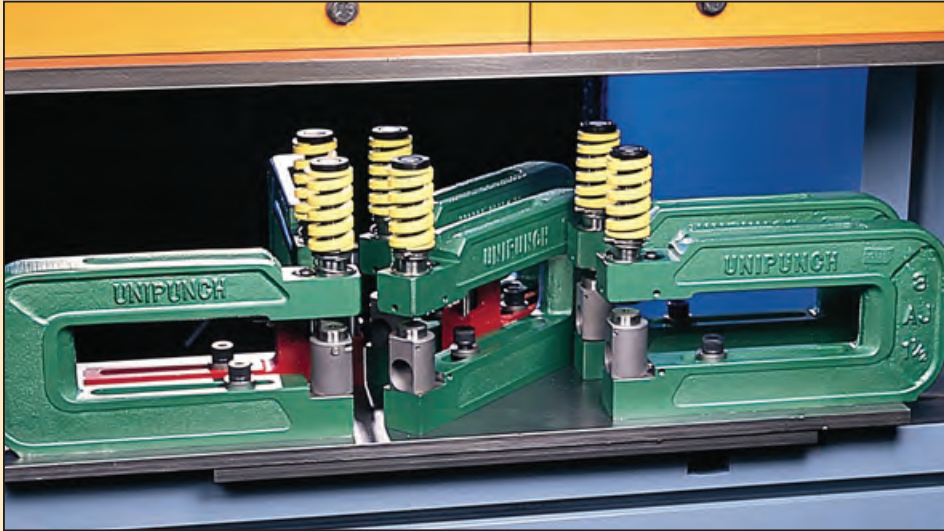

DEDICATED TEMPLATE METHOD

- The most popular method for all material thicknesses.
- Make identical parts consistently.
- Allows units to be mounted outside the press for fast changeover at the press.

MOUNTING

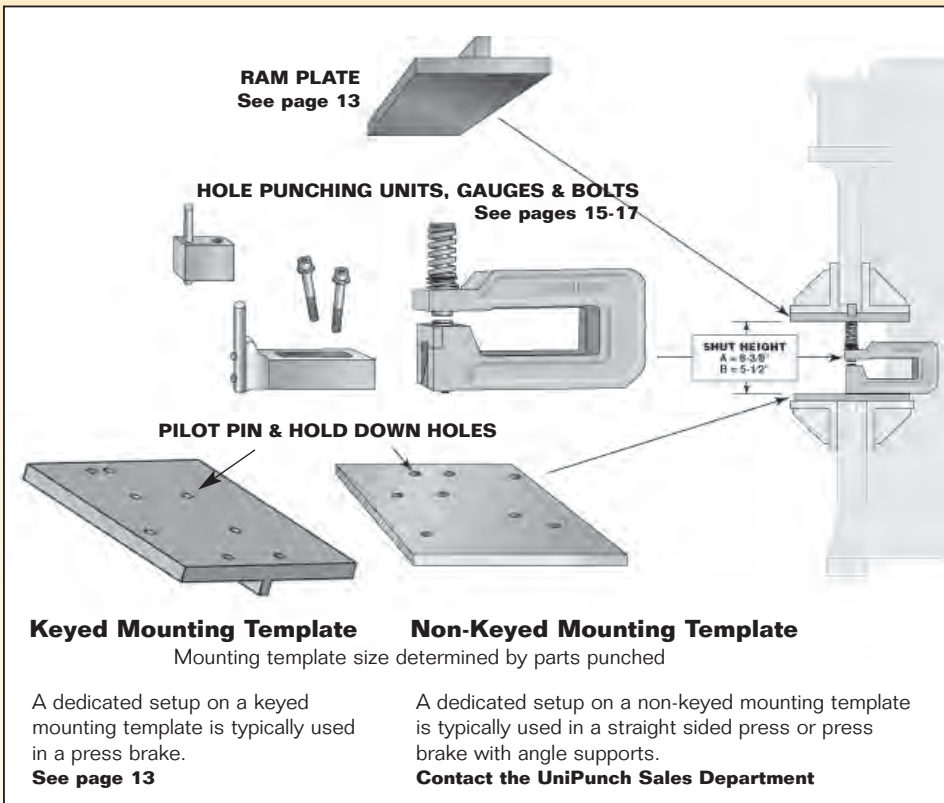

SPEED WITHIN REACH

UNIPUNCH

Creating Prototypes In Press Brakes

Unispacers fit into the recess in the Bed Rail and permit straight line punching of prototypes in flat metal, extrusions and structural shapes. If the preliminary hole locations change, Unispacers offer a quick and easy method to relocate the holes... simply reposition the Unispacers on the Bed Rail. For a staggered line of holes, use the slotted side of the Unispacer.

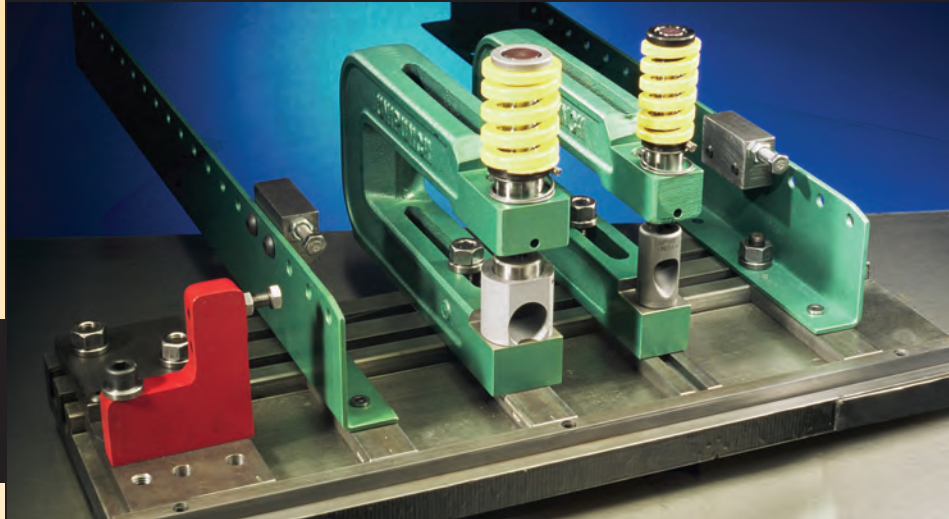

BED RAIL / UNISPACER METHOD

- For prototype or short run straight line punching applications with varying part lengths.
- Quick and easy set up and relocation of holes makes this a preferred mounting method.
- Unispacer fits into Bed Rail recess.
- Unispacer has two .376" diameter holes on one side to accept unit pilot pins and .376" slot on opposite side for unit front to back adjustment.

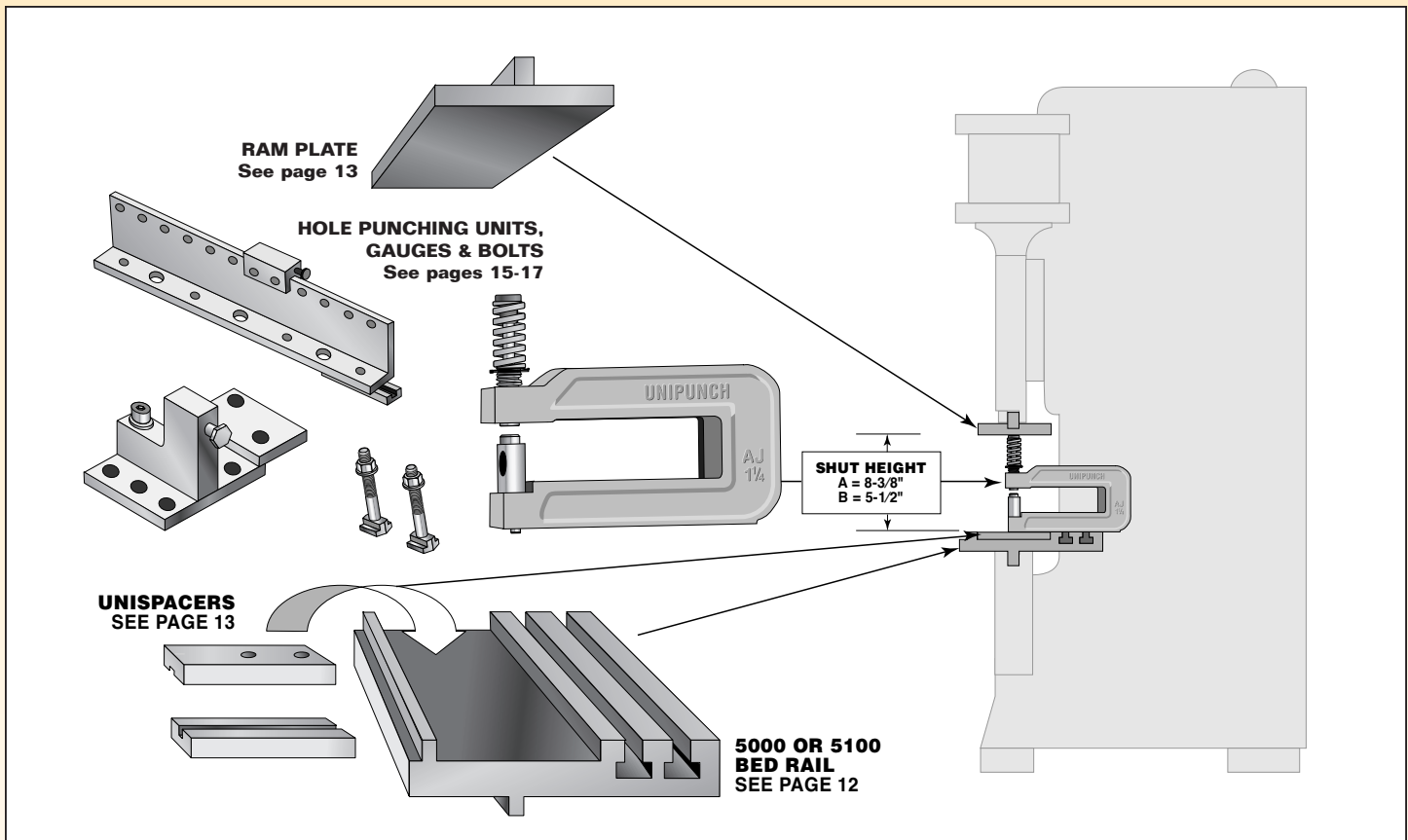

Mounting: The Basic Steps

It's easy to start using UniPunch tooling. This overview demonstrates using the UniPunch modular system in a dedicated setup. Here's how...

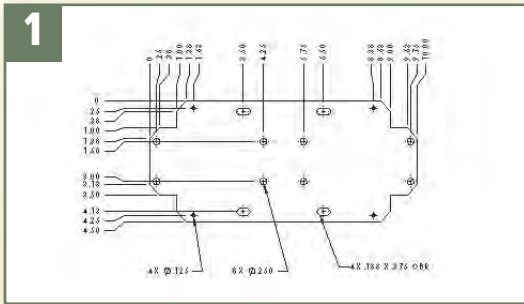

1 Start by sending us a drawing or sample part.



2 Based on your requirements, UniPunch will recommend appropriate tooling and gauging.

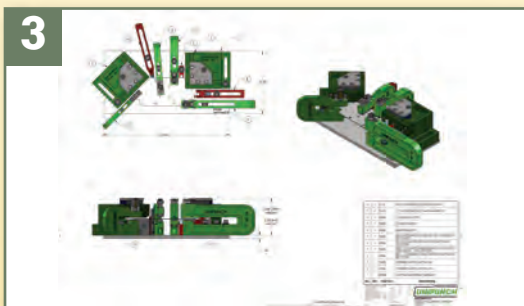

3 Once an order is placed, UniPunch will provide a layout drawing for your approval.

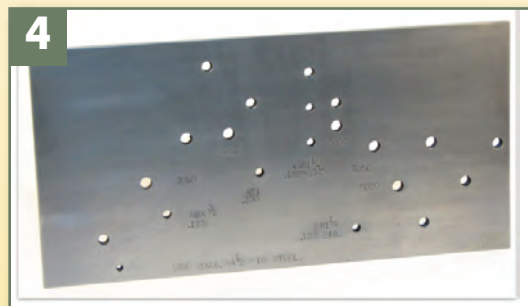

4 With your approval, UniPunch will manufacture the mounting template to precisely locate the holes according to your specifications.



5 UniPunch will ship the appropriate tooling along with the template.

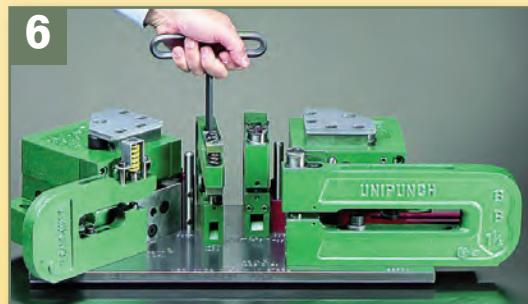

6 When you receive the tooling you will assemble the units on the template using the provided layout drawing.

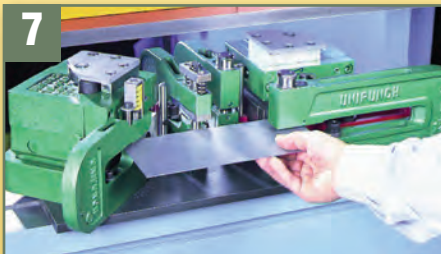

7 Depending on the application, material can be hand fed (as shown) or fed off a coil.

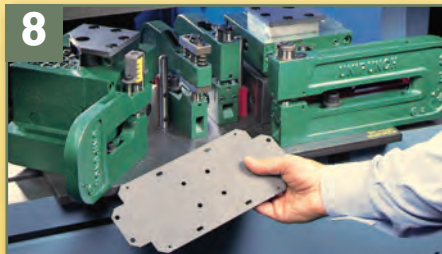

8 You can punch and notch multiple holes with each stroke of the press.



9 The tooling in the dedicated setup is assigned to the part for the life of the part. Here it is shown stored on a shelf, ready for the next time that part is required.

If the part is no longer required, the modular tooling can be disassembled and remounted on a new template for a different part.

Bed Rails and Template Mounting Plate

Bed Rails — Versatile means of mounting UniPunch modular A & B Series tooling and gauges on press brakes

- Mainly used for straight line punching within a 4⁷/₈" (123.8mm) area front to back.
- Two styles available — 5000 & 5100 in lengths up to 12'.
- A Strip Template or Unispacer fits into recess area to support tooling. Units are positioned with pilot pins located in reamed holes and then bolted to T-slots at rear of Bed Rail.
- Style 5100 is available with a 1/2" (12.7mm) key slot in template recess area to accept a press brake bending die, allowing parts to be punched and brake-formed in same setup.

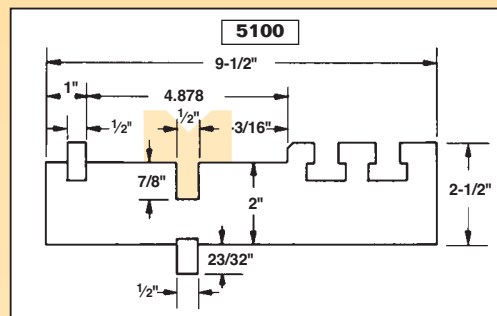
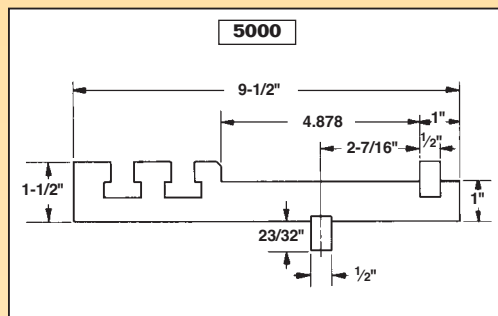

BED RAIL No. 5000		
Part No.	Length	Weight
5000-24	24"	70 lbs.
5000-48	48"	140 lbs.
5000-72	72"	210 lbs.
5000-96	96"	280 lbs.
5000-120	120"	350 lbs.
5000-144	144"	420 lbs.

BED RAIL No. 5100		
Part No.	Length	Weight
5100-24	24"	124 lbs.
5100-48	48"	248 lbs.
5100-72	72"	372 lbs.
5100-96	96"	496 lbs.
5100-120	120"	620 lbs.
5100-144	144"	744 lbs.

Bed Rails, G-Series — for mounting UniPunch modular single & triple spring G-Series tooling and end gauge on press.

The UniPunch 5110 Bed Rail is designed with one T-slot and a top mounted key that accurately positions the G-Series fixed base units for straight line punching or the G-Series adjustable base units for staggered hole patterns.

BED RAIL No. 5110		
Part No.	Length	Weight
5110-48	48"	92 lbs.
5110-72	72"	138 lbs.
5110-96	96"	184 lbs.
5110-120	120"	230 lbs.
5110-144	144"	276 lbs.

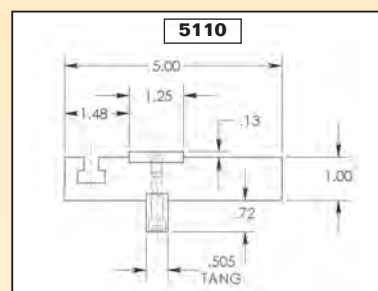

Unispacers, Keyed Mounting Templates and Ram Plates

Unispacers

- Unispacers fit into the recess in the 5000 & 5100 Bed Rails for punching holes in prototype parts. The Unispacer aligns units for shaped hole punching.
- For staggered hole patterns, Unispacers are turned over and unit pilot pins are inserted in the slot.

UNISPACERS	
Part No.	For Use With Units
5060	Up to 1" wide
5061	1 ¼" to 2" wide
5062	2 ¼" to 3" wide
5067	3 ½" wide
5069	4" wide
5068	5" wide
5064	5 x 5 Notching Units



Keyed Mounting Templates – Used to support and position UniPunch modular tooling and gauges within a press brake.

- Typically made from ¾" (19mm) HRS. CRS or Aluminum are made upon request. Other template thicknesses are available upon request.
- Drilled and reamed holes are in precise locations of the part to be punched.
- For pricing of all templates, contact the UniPunch Sales Department.

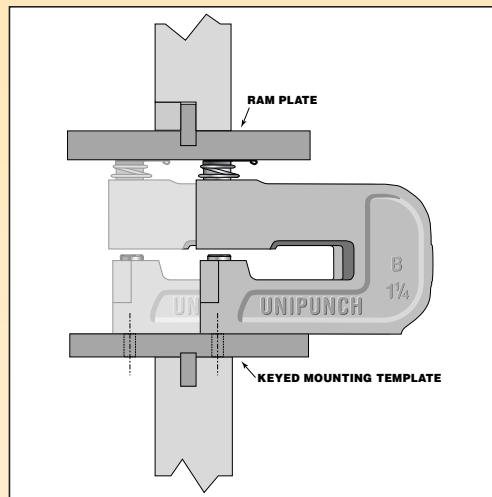

Keyed Mounting Templates are supplied with press brake key in bottom.

MOUNTING

Ram Plates – Provide additional ram area for staggered hole patterns.

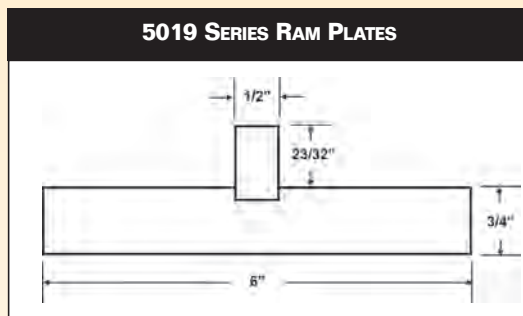

5019 SERIES RAM PLATES		
Part No.	Length	Weight
5019-24	24"	33 lbs.
5019-48	48"	66 lbs.
5019-72	72"	96 lbs.
5019-96	96"	128 lbs.
5019-120	120"	160 lbs.
5019-144	144"	192 lbs.

For custom designed Ram Plates, contact the UniPunch Sales Department.

T-Slotted Plates and Universal Base Plates

T-Slotted Plates – Used to mount modular tooling and gauges in punch presses or stamping presses.

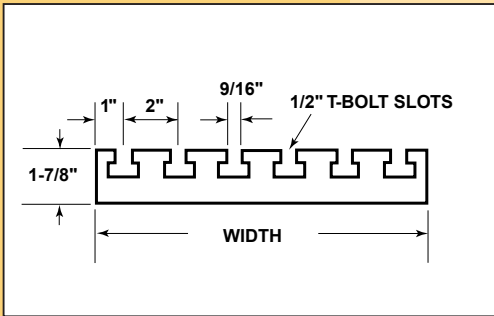

First two digits of part number indicate the width and the last two (or three) digits indicate the length.

T-Slotted Plates, other than sizes shown, are available upon request. Contact the UniPunch Sales Department.

PP SERIES T-SLOTTED PLATES	
Part No.	Weight
PP-1248	220
PP-1272	330
PP-12108	495
PP-12120	550
PP-12144	660
PP-1848	320
PP-1872	480
PP-18108	719
PP-18120	799
PP-18144	959
PP-2436	321
PP-2448	428
PP-2472	642
PP-24108	962
PP-24120	1069
PP-24144	1284
PP-3036	405
PP-3048	540
PP-3072	810
PP-30108	1215
PP-30120	1350
PP-30144	1620

- Can be used in press brakes with angle support brackets. A 1/2" (12.7mm) mounting key is available upon request.
- Standard widths from 12" (304.8mm) to 30" (762mm).

Universal Base Plates – Made of 3/4" (19.05mm) thick steel plate and completely covered with uniform pattern of 1/2"-13 tapped holes for bolting units in position.

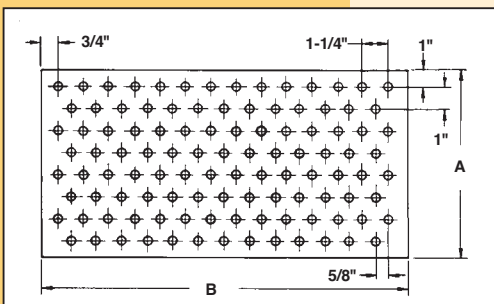

First two digits of part number indicate the width "A" and the last two or three digits indicate the length "B". Special sizes made to order.

Special order Universal Base Plates can be made from aluminum tooling plate.

Universal Base Plates, other than sizes shown, are available upon request. For pricing, contact the UniPunch Sales Department.

UB SERIES UNIVERSAL BASE PLATES	
Part No.	Part No.
UB-1224	UB-1872
UB-1236	UB-2424
UB-1248	UB-2436
UB-1260	UB-2448
UB-1272	UB-2460
UB-1824	UB-2472
UB-1836	UB-3036
UB-1848	UB-3048
UB-1860	UB-3060

- Light weight for easier handling and storage.
- Ideal for short runs of small and medium sized parts.
- Standard widths from 12" (304.8mm) to 30" (762mm).

Mounting Accessories

UniPunch offers a variety of mounting accessories, gauges (stops), part supports (feed rails), wrenches and hold down bolts to provide fast and easy assembly of modular tooling. The mounting accessories you will require depends on the mounting method you select and the type of part being punched.

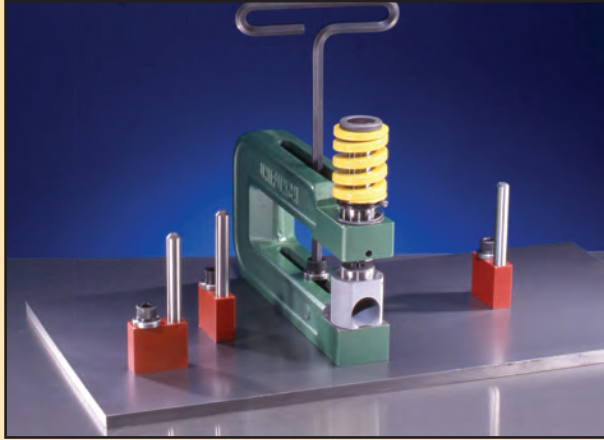

Typical 3-pin gauging Template Mounting

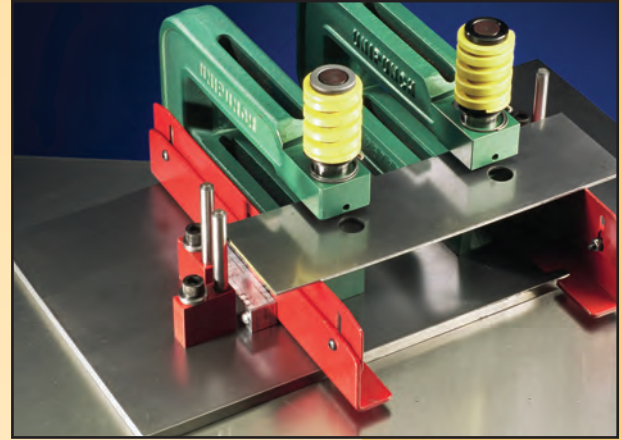

Complete Setup with Accessories

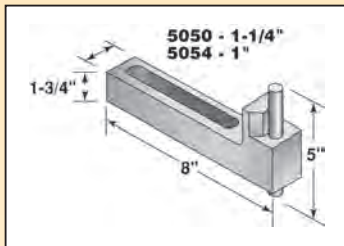

UNIVERSAL STOPS

Description	Part No.
Universal Stop (1 1/4" Wide)	5050
Universal Stop (1" Wide)	5054



For use with template or T-Slotted Plate mounting setups with either 'A' or 'B' Series Units. A built in screw adjustment for variations in stock dimensions may be used by removing gauge pin and gauging against screw.

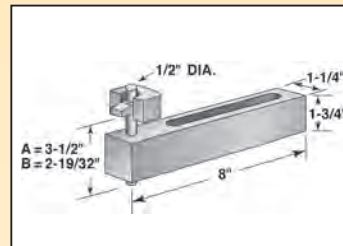

MAGNETIC STOPS

Description	Part No.
Magnetic Stop	5088
Magnet Only	5083



For template, T-slotted plate and Bed Rail mounting setups, these Magnetic Stops insure accurate gauging of all work pieces. The part is magnetically held, eliminating the necessity for the operator to hold the part against the stop.

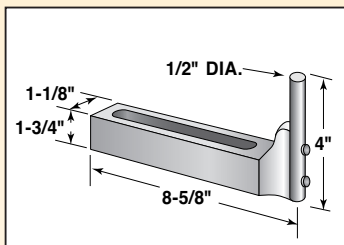

CLOSE EDGE STOPS

Part. No.
5084

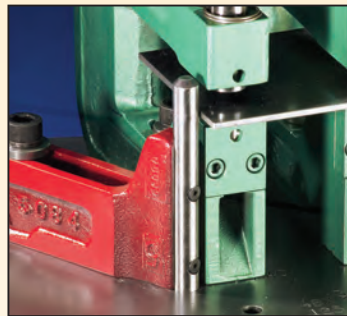

Close Edge Stops allow units to be set closer together and still have room for gauges.

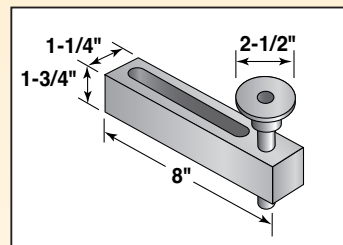

CLOSE EDGE STOPS (DISC)

Description	Part. No.
Complete Ass'y	5099
Disc Only	5103



Disc Gauge allows work piece to be gauged inside a holder close to die. Disc can be adjusted to 'A' or 'B' Series die heights.

Mounting Accessories

DOWEL PIN STOPS

Description	Part No.
A & B Series	5055

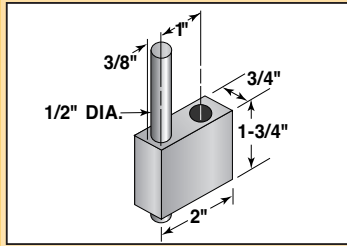

This economical stop is designed for use with 'A' or 'B' Series units on template mounting.

ADJUSTABLE STOPS

Description	Part No.
A Series	5092
B Series	5052

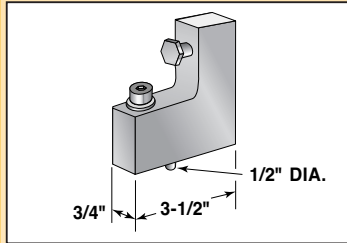

Adjustable Stop has an adjustment screw for quick compensation of various work piece sizes.

ADJUSTABLE END STOPS AND SPACER ASSEMBLY

Description	Part No.
A Series	5135
B Series	5125

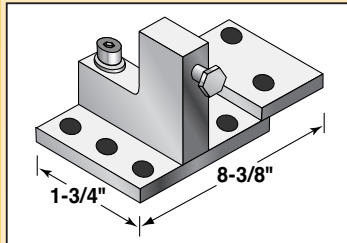

These End Stops are adjustable front-to-back in three positions on Unispacer.

DISAPPEARING PIN STOPS

Description	Part No.
A Series	5048
B Series	5044

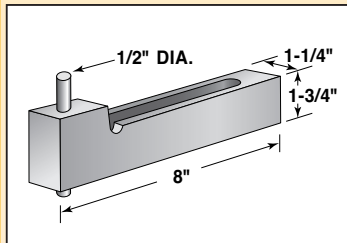

Disappearing Pin Stops are spring loaded and are used for edge and end gauging in progressive operations.

PICKUP GAUGES — FIXED (1 1/4" WIDTH)

Description	A SERIES		B SERIES	
	Part No.	Part No.	Part No.	Part No.
Gauge for 1/2" Dia. & Under	5056-1	5058-1	5058-1	5058-1
Replacement Tip for Above	5057-1	5059-1	5059-1	5059-1
Gauge for Over 1/2" Dia.	5056-2	5058-2	5058-2	5058-2
Replacement Tip for Above	5057-2	5059-2	5059-2	5059-2

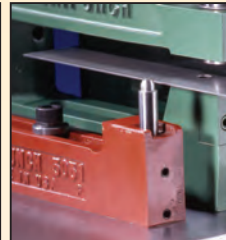
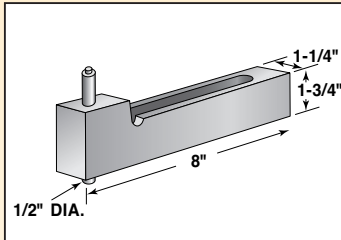

Specify hole size when ordering gauges. UniPunch stationary Pickup gauges are used to engage previously punched holes. Designed specially for pass-along multiple hit operations.

PICKUP GAUGES — SPRG. LD. (1 1/4" WIDTH)

Description	A SERIES		B SERIES	
	Part No.	Part No.	Part No.	Part No.
Gauge for 1/2" Dia. & Under	5046-1	5042-1	5042-1	5042-1
Replacement Tip for Above	5047-1	5043-1	5043-1	5043-1
Gauge for Over 1/2" Dia.	5046-2	5042-2	5042-2	5042-2
Replacement Tip for Above	5047-2	5043-2	5043-2	5043-2

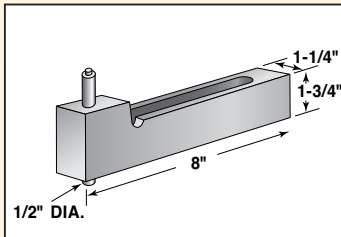

Specify hole size when ordering gauges. This UniPunch gauge is used in operations requiring retractable pickup pins, such as multiple hit setups.

Mounting Accessories

FEED RAILS

Description	Part No.
Non-Magnetic	5038
Magnetic	5039

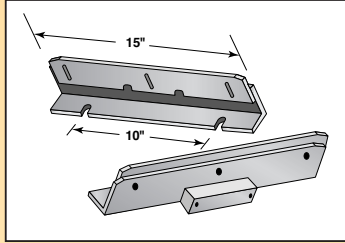

Feed Rails are adjustable in height for use with both 'A' and 'B' Series units for unobstructed sliding of part into position. The Magnetic Feed Rails are simply placed on mounting plates eliminating hold down bolts.

* ADJUSTABLE BACK STOPS

Description	Part No.
A Series Adj.	5120
B Series Adj.	5130

* Back Stop & Unispacer Assemblies.

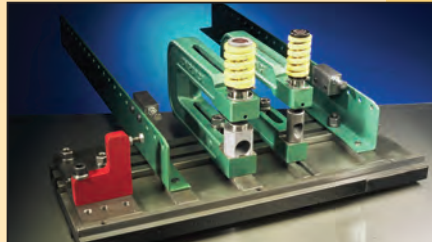
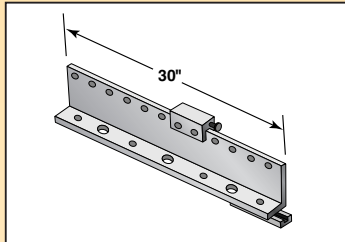

For use on 5000 and 5100 series bed rails to back gauge and support part.

ADJUSTABLE BACK GAUGES

Part No.
1220

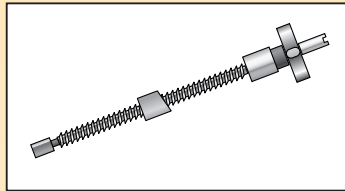

The Adjustable Back Gauge is used to accurately position parts. Most holders can be drilled for back gauge by customer or at factory for an additional charge. This $\frac{1}{16}$ " hole is located $3\frac{1}{16}$ " from base on 'A' Units and $2\frac{9}{16}$ " on 'B' Units.

LOCATOR PINS

For Use With Units	Part No.
A-1, A-1 $\frac{1}{4}$, AJ-1, AJ-1 $\frac{1}{4}$	1055
A-1 $\frac{1}{2}$, AJ-1 $\frac{1}{2}$	1056
A-2, AJ-2	1057
B-1, B-1 $\frac{1}{4}$	1050
B-1 $\frac{3}{4}$	1051
BX-2 $\frac{1}{4}$	1052
G- $\frac{3}{4}$, BX- $\frac{3}{4}$	1064

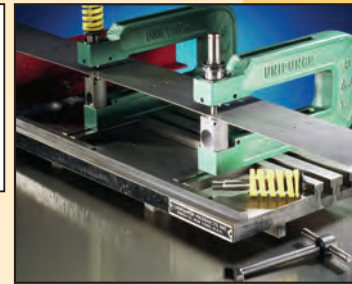
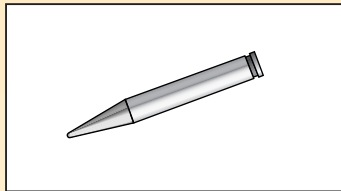

For locating units in position with actual part on T-Slotted Plate or Bed Rail.

NUT, BOLT AND WASHER SETS

Part No.	Dia.	Length	Used With
5010	$\frac{1}{2}$ "	$3\frac{1}{4}$ "	Quick-Lock B-BX-A-AJ
5035	$\frac{1}{2}$ "	$3\frac{1}{4}$ "	Sq. Head Bolt B-BX-A-AJ
5113	$\frac{1}{2}$ "	4"	Sq. Head Bolt — AH
5151	$\frac{5}{16}$ "	$3\frac{1}{8}$ "	BX- $\frac{3}{4}$
5143	$\frac{5}{16}$ "	1"	G

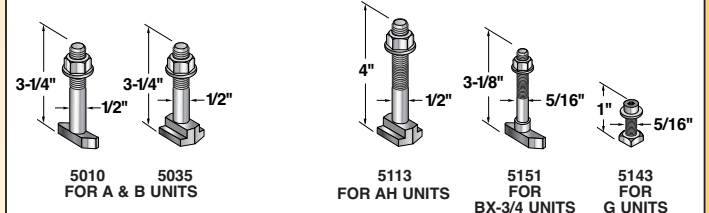

TEMPLATE MOUNTING SCREWS AND WASHER

Part No.	Dia.	Length	Used With
5141-12	$\frac{1}{2}$ "	$2\frac{1}{4}$ "	B-BX-A-AJ
5012-12	—	—	Washer Only
5104-12	$\frac{1}{2}$ "	3"	AH
5150-12	$\frac{5}{16}$ "	$2\frac{1}{4}$ "	BX- $\frac{3}{4}$ "
5003-12	—	—	Washer Only

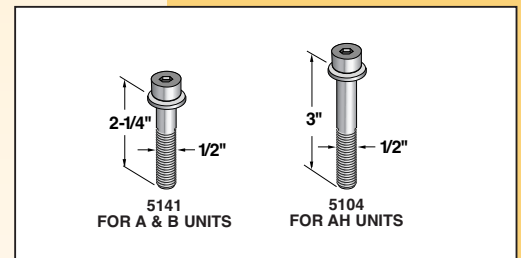

All bolts are specially designed for mounting UniPunch units and accessories to Templates, T-Slotted Plates and Bed Rails.

Mounting Accessories

*1/2-13 Hex T Wrench

Part No.

1193



* For 1/2-13 S.H.C.S.
Designed for efficiency,
the special loop handle
on the wrench makes the
hex key easier to use.

UNIKEY WRENCHES

Part No.

1070

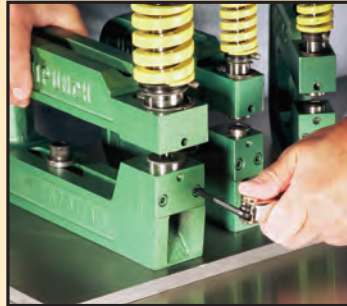

This Hex wrench
includes most of
the standard hex
sizes required for
UniPunch unit
screws and bolts.

TEMPLATE LAYOUT DESIGN INFORMATION

UniPunch can provide CAD files of units for use in creating templates. The formats that are available are DXF (2D footprint), DWG (2D footprint) and STEP (3D model). Contact the UniPunch Sales Department at info@unipunch.com

A Series Lineup

A, AJ, AJD, AH, AHD, OA, AD, FCU, A-Notching and A-Shearing

- 8-3/8" shut height & 3-1/2" die height
- Material Thickness: Up to 3/4"
- Part Feed Clearance from 7/16" to 1-1/4"

A Units (Pages 22 - 29)

The "A" punching units are the workhorses of the UniPunch product line. Available "A" holder widths are: 1", 1 1/4", 1 1/2", 2", 2 1/2", 3", 3 1/2", 5 1/2" and 8". Holder width is important because it defines the minimum hole to hole distance. The "A" Series are widely used in industry to punch mild steel up to 1/4" thickness. Depending on your material thickness, punch diameters are available up to 5.000" (127mm).

AJ Units (Pages 30 - 34)

"AJ" punching units are ideal for punching angles and channels, aluminum extrusions and other formed parts. Available "AJ" holder widths are: 1", 1 1/4", 1 1/2", 2" and 2 1/2". Holder width is important because it defines the minimum hole to hole distance. The "AJ" units are widely used in industry to punch mild steel up to 1/4" thickness. Depending on your material thickness, punch diameters are available up to 1.500" (38.10mm).

The "AJ" Unit assembled with Pedestal Die uses a one piece pedestal die for punching close to a leg of angles, channels and extrusions. Pedestal dies are routinely modified to accommodate formed parts.

The "AJ" Unit assembled with Die Adapter is a two piece design; the die adapter accepts a button die. One benefit of using the "AJ" Unit with a die adapter is the ability to change button die sizes for multiple materials, at a lower cost.

A SERIES



Pedestal Dies are an alternative to die adapters. They can be modified to allow punching holes in oddly shaped angles, channels, and extrusions as illustrated above.

Two common types of altered pedestal dies are shown below; others are available. Submit a drawing of your part to the UniPunch Sales Department for a tooling recommendation.

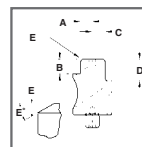

1288 Altered Ped Die - Flats

Required parameters

A = Front Flat Location
 B = Front Flat Height
 C = Rear Flat Location
 D = Rear Flat Height
 E = Chamfer
 Specify Dia. or Shape
 TDC - Total Die Clearance

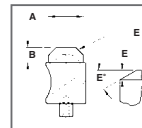

1289 Altered Ped Die - Boss

Required parameters

A = Top Diameter
 B = Front/Top Height
 E = Chamfer - 45° unless otherwise requested
 Specify Dia. or Shape
 TDC - Total Die Clearance

Feed Clearance Units "FCU" (Page 35)

"FCU" punching units feature extra wide feed openings that allow you to "front feed" parts such as channels, angles and extrusions. Available holder widths are: 1 1/4", 1 1/2" and 2 1/4". These units are used to punch mild steel up to 1/8" thickness. Depending on your material thickness, punch diameters are available up to .8750" (22.22mm). (For thicker material punching applications, see the "AJ" Series.)

SPEED WITHIN REACH

UNIPUNCH

A Series Lineup

A, AJ, AJD, AH, AHD, OA, AD, FCU, A-Notching and A-Shearing

- 8-3/8" shut height & 3-1/2" die height
- Material Thickness: Up to 3/4"
- Part Feed Clearance from 7/16" to 1-1/4"

AH Units (Pages 36 - 39)

"AH" punching units are in the UniPunch product line to offer tooling that can punch 1 1/2" round holes in mild steel up to 1/2" thick. For thinner material, punch diameters are available up to 3.000" (76.20mm). Available "AH" holder widths are: 2 1/2", 3", 3 1/2" and 6".

OA Unit (Page 40)

The "OA" unit is an oversized AH-6 unit providing additional hole diameter capacity. It offers the capability of punching up to a 4.000" diameter hole in 3/16" mild steel.

AD Unit (Page 41)

The "AD" unit is in the UniPunch product line to offer the capability of punching holes in up to 3/4" thick mild steel. It features two sets of 24 disc springs in order to strip the punch from such thick material. The "AD" unit is a 4" wide holder. Depending on your material thickness, punch diameters are available up to 1.125" (28.57mm).

AJD (Formerly part of the D Series) (Page 42)

Standard "AJ" units are limited to punching up to 1/8" thick stainless steel. "AJD" units are UniPunch standard 2" wide "AJ" units assembled with premium D2 tool steel punches for reduced wear when punching up to 1/2" diameter holes in stainless steel up to 1/4" thick.

AHD Units (Formerly part of the D Series) (Pages 43 - 45)

"AH" units are limited to punching up to 5/32" thick stainless steel. "AHD" units are UniPunch standard "AH" units assembled with premium D2 tool steel punches for reduced wear when punching up to 1 1/2" diameter holes in stainless steel up to 1/4" thick. Available "AHD" holder widths are: 2 1/2", 3" and 3 1/2".

A Series Lineup

A, AJ, AJD, AH, AHD, OA, AD, FCU, A-Notching and A-Shearing

- 8-3/8" shut height & 3-1/2" die height
- Material Thickness: Up to 3/4"
- Part Feed Clearance from 7/16" to 1-1/4"

A Series Notching Units (Pages 48 & 51)

These units are designed to operate as stand-alone tools or can be used in conjunction with the UniPunch "A" Series Lineup to punch and notch parts up to 1/4" (6.4mm) thick mild steel in the same press setup.



Corner Notching Units (Page 48)

UniPunch "A" Series **Corner Notch Units** are self-contained dies available in 90 degree left hand or right hand units. Two models are offered for corner notch sizes of up to 3" x 3" or 5" x 5". Die clearance is pre-set at the factory for notching up to 1/4" (6.4mm) mild steel. Replacement punch and die blades, springs and other components are available from stock. Units for custom corner configurations are available.



A Series Flat Stock Cutoff Unit (Page 51)

UniPunch "A" Series **6300 Flat Stock Cutoff Units** are self-contained two post die shearing units available in widths up to 8" (203.2mm). These units can be mounted in a press or press brake in conjunction with other "A" Series tooling, or can be used for stand-alone cut-to-length applications in mild steel up to 1/4" (6.4 mm) thickness. Other widths can be manufactured to your requirements.

A-1[®]

25.4mm width

SPECIFICATIONS & OPERATING INSTRUCTIONS

OPERATING SHUT HEIGHT:	8-3/8" (212.7mm)
MIN. SHUT HEIGHT:	8-3/16" (208.0mm)
UNIT OPEN HEIGHT:	9-1/8" (231.8mm)
DIE HEIGHT:	3-1/2" (88.9mm)
MATERIAL FEED CLEARANCE:	7/16" (11.1mm)
MIN. DIE CLEARANCE:	.006" (.15mm)
MAX. MAT. THK. (M.S.):	1/4" (6.4mm)

MAX. PUNCH DIAMETER:	.3125" (7.93mm) in 1/4" (6.4mm) M.S. .4375" (11.11mm) in 1/8" (3.18mm) M.S.
MIN. PUNCH DIAMETER:	.0937" (2.38mm)
MAX. SQUARE:	.309" (7.85mm)
MIN. SHAPE DIMENSION:	.0937" (2.38mm)
MAX. MAT. THK. (S.S.):	3/32" (2.4mm)

KITS AND SHIMS

Shaped hole conversion kit:	7111
Key kit:	9300
Hardware kit:	9393
Punch shim:	N.A.
Die shim:	1091-12 pk. 1091-48 pk. 1/16" thk./2 max.
Upper arm kit:	9731 Round 9732 Shaped

	ROUND UNITS		*SHAPED UNITS		COMMON DIMS.		
	Model No.	Part No.	Model No.	Part No.	Throat Depth	Length A	Shipping Weight
BASE UNITS LESS PUNCH & DIE	4A-1-LPD	2003-LPD	4SA-1-LPD	2005-LPD	4"	7"	8 lbs.
	8A-1-LPD	2000-LPD	8SA-1-LPD	2006-LPD	8"	11"	10 lbs.
	12A-1-LPD	2001-LPD	12SA-1-LPD	2007-LPD	12"	15"	13.5 lbs.
COMPLETE UNITS (Includes Punch & Die)	4A-1	2003	4SA-1	2005	4"	7"	8.5 lbs.
	8A-1	2000	8SA-1	2006	8"	11"	10.5 lbs.
	12A-1	2001	12SA-1	2007	12"	15"	14 lbs.

*To order a shaped unit with round punch & die, add the suffix "- RPD"

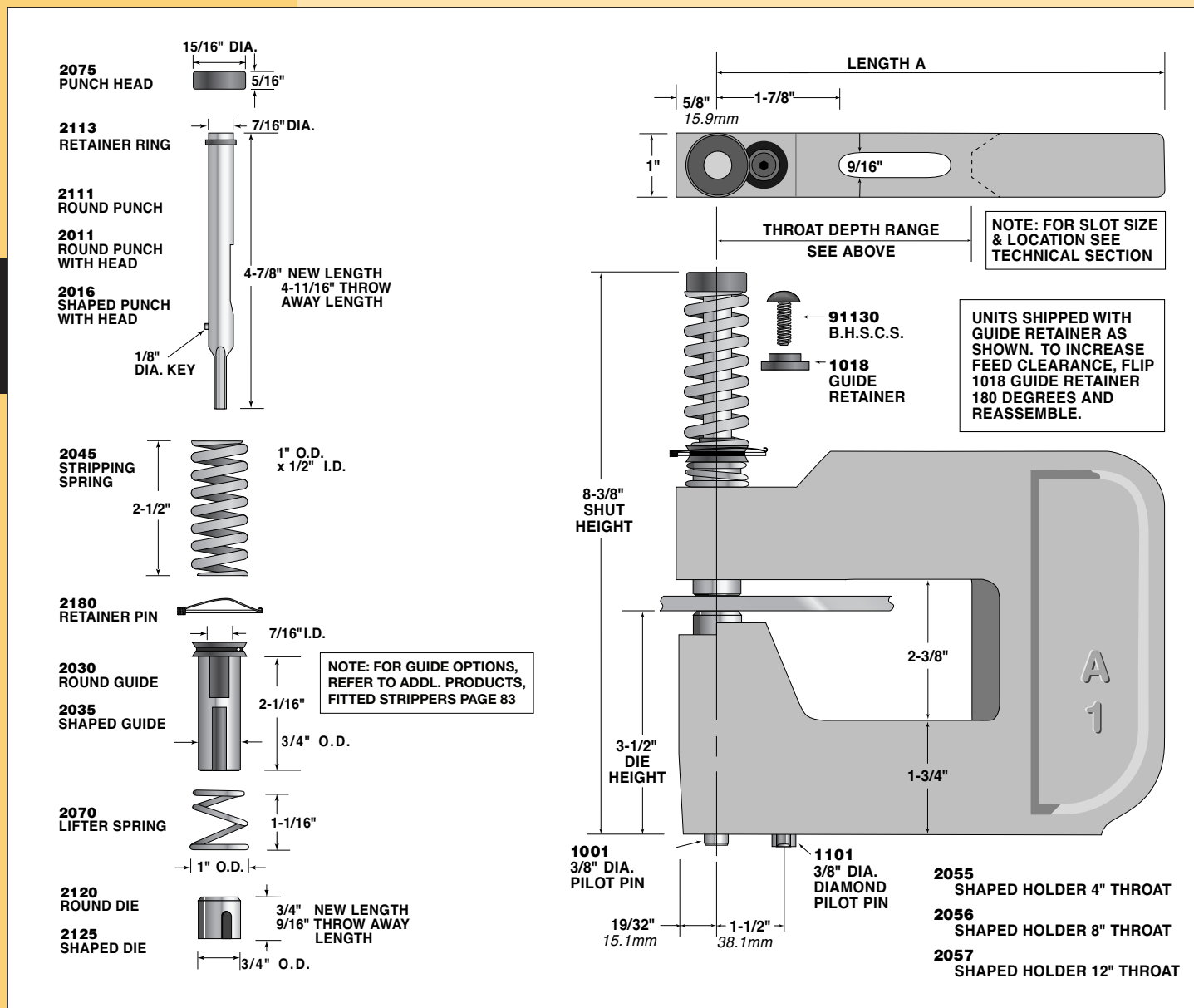

SPEED WITHIN REACH

UNIPUNCH

SPECIFICATIONS & OPERATING INSTRUCTIONS

OPERATING SHUT HEIGHT:	8-3/8" (212.7mm)	MIN. DIE CLEARANCE:	.006" (.15mm)
MIN. SHUT HEIGHT:	8-3/16" (208.0mm)	MAX. PUNCH DIAMETER:	.4375" (11.11mm)
UNIT OPEN HEIGHT:	9-1/8" (231.8mm)	MIN. PUNCH DIAMETER:	.0937" (2.38mm)
DIE HEIGHT:	3-1/2" (88.9mm)	MAX. SQUARE:	.309" (7.85mm)
MATERIAL FEED CLEARANCE:	7/16" (11.1mm)	MIN. SHAPE DIMENSION:	.0937" (2.38mm)
MAX. MATERIAL THICKNESS (MILD STEEL):	1/4" (6.4mm)	MAX. MATERIAL THICKNESS (STAINLESS STEEL):	3/32" (2.4mm)

A-1 1/4" 31.8mm width

	ROUND UNITS		*SHAPED UNITS		COMMON DIMS.		
	Model No.	Part No.	Model No.	Part No.	Throat Depth	Length A	Shipping Weight
BASE UNITS LESS PUNCH & DIE	4A-1 1/4-LPD	2103-LPD	4SA-1 1/4-LPD	2105-LPD	4"	7"	11.5 lbs.
	8A-1 1/4-LPD	2100-LPD	8SA-1 1/4-LPD	2106-LPD	8"	11"	13 lbs.
	12A-1 1/4-LPD	2101-LPD	12SA-1 1/4-LPD	2107-LPD	12"	15"	15.5 lbs.
COMPLETE UNITS (Includes Punch & Die)	4A-1 1/4	2103	4SA-1 1/4	2105	4"	7"	12 lbs.
	8A-1 1/4	2100	8SA-1 1/4	2106	8"	11"	13.5 lbs.
	12A-1 1/4	2101	12SA-1 1/4	2107	12"	15"	16 lbs.

*To order a shaped unit with round punch & die, add the suffix "- RPD"

KITS AND SHIMS

Shaped hole conversion kit:	7112
Key kit:	9300
Hardware kit:	9394
Punch shim:	N.A.
Die shim:	1091-12 pk. 1091-48 pk. 1/16" thk./3 max.
Upper arm kit:	9733 Round 9734 Shaped

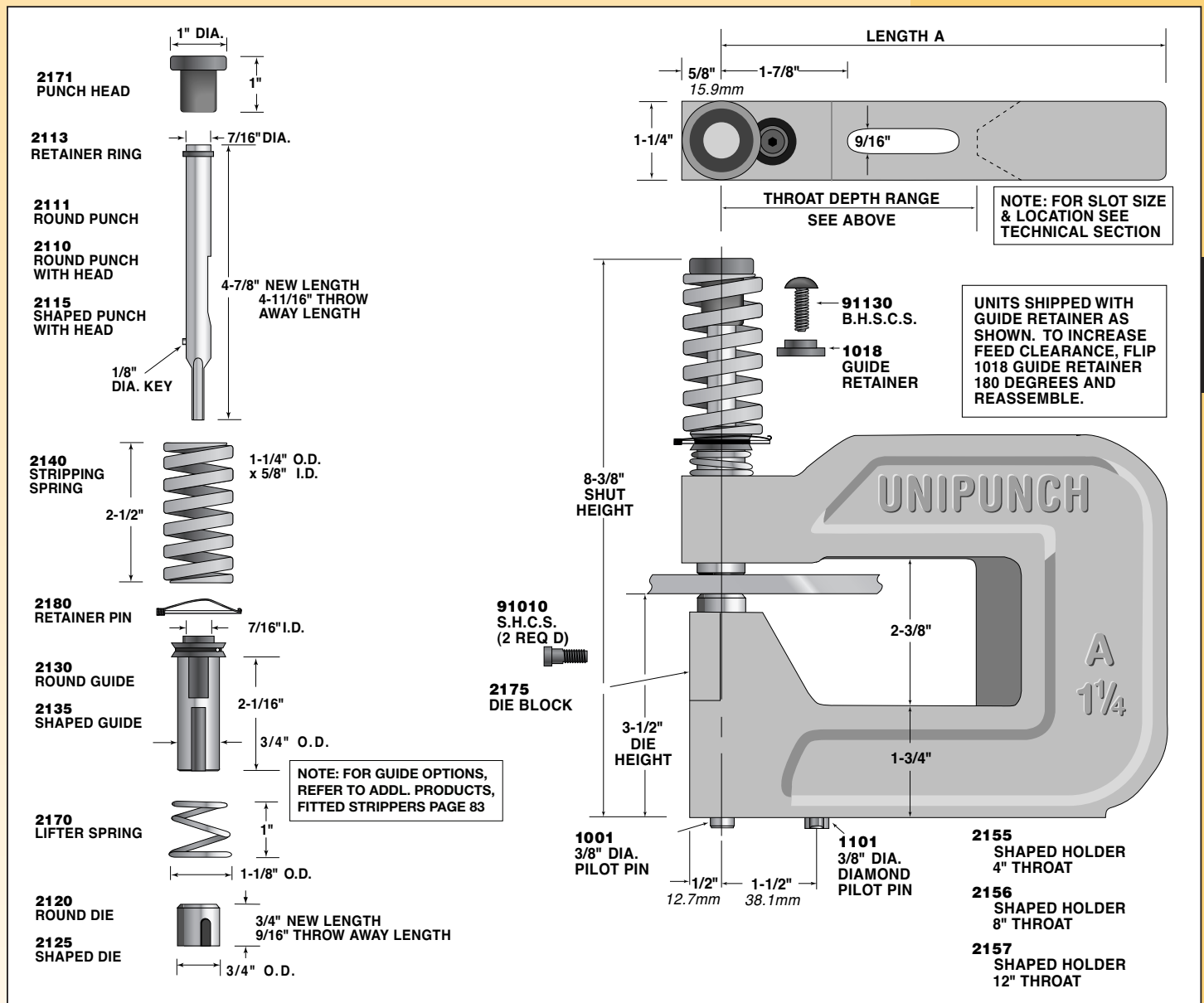

A SERIES

A-1 1/2"

38.1 mm width

SPECIFICATIONS & OPERATING INSTRUCTIONS

OPERATING SHUT HEIGHT:	8-3/8" (212.7mm)	MIN. DIE CLEARANCE:	.006" (.15mm)
MIN. SHUT HEIGHT:	8-3/16" (208.0mm)	MAX. PUNCH DIAMETER:	.6250" (15.87mm)
UNIT OPEN HEIGHT:	9-1/8" (231.8mm)	MIN. PUNCH DIAMETER:	.1250" (3.18mm)
DIE HEIGHT:	3-1/2" (88.9mm)	MAX. SQUARE:	.441" (11.20mm)
MATERIAL FEED CLEARANCE:	7/16" (11.1mm)	MIN. SHAPE DIMENSION:	.0937" (2.38mm)
MAX. MATERIAL THICKNESS (MILD STEEL):	1/4" (6.4mm)	MAX. MATERIAL THICKNESS (STAINLESS STEEL):	3/32" (2.4mm)

KITS AND SHIMS

Shaped hole conversion kit:	7113
Key kit:	9300
Hardware kit:	9394
Punch shim:	N.A.
Die shim:	1092-12 pk. 1092-48 pk. 1/16" thk./3 max.
Upper arm kit:	9735 Round 9736 Shaped

	ROUND UNITS		*SHAPED UNITS		COMMON DIMS.		
	Model No.	Part No.	Model No.	Part No.	Throat Depth	Length A	Shipping Weight
BASE UNITS LESS PUNCH & DIE	4A-1 1/2-LPD	2203-LPD	4SA-1 1/2-LPD	2205-LPD	4"	7"	13.5 lbs.
	8A-1 1/2-LPD	2200-LPD	8SA-1 1/2-LPD	2206-LPD	8"	11"	16.5 lbs.
	12A-1 1/2-LPD	2201-LPD	12SA-1 1/2-LPD	2207-LPD	12"	15"	19.5 lbs.
COMPLETE UNITS (Includes Punch & Die)	4A-1 1/2	2203	4SA-1 1/2	2205	4"	7"	14 lbs.
	8A-1 1/2	2200	8SA-1 1/2	2206	8"	11"	17 lbs.
	12A-1 1/2	2201	12SA-1 1/2	2207	12"	15"	20 lbs.

*To order a shaped unit with round punch & die, add the suffix "- RPD"

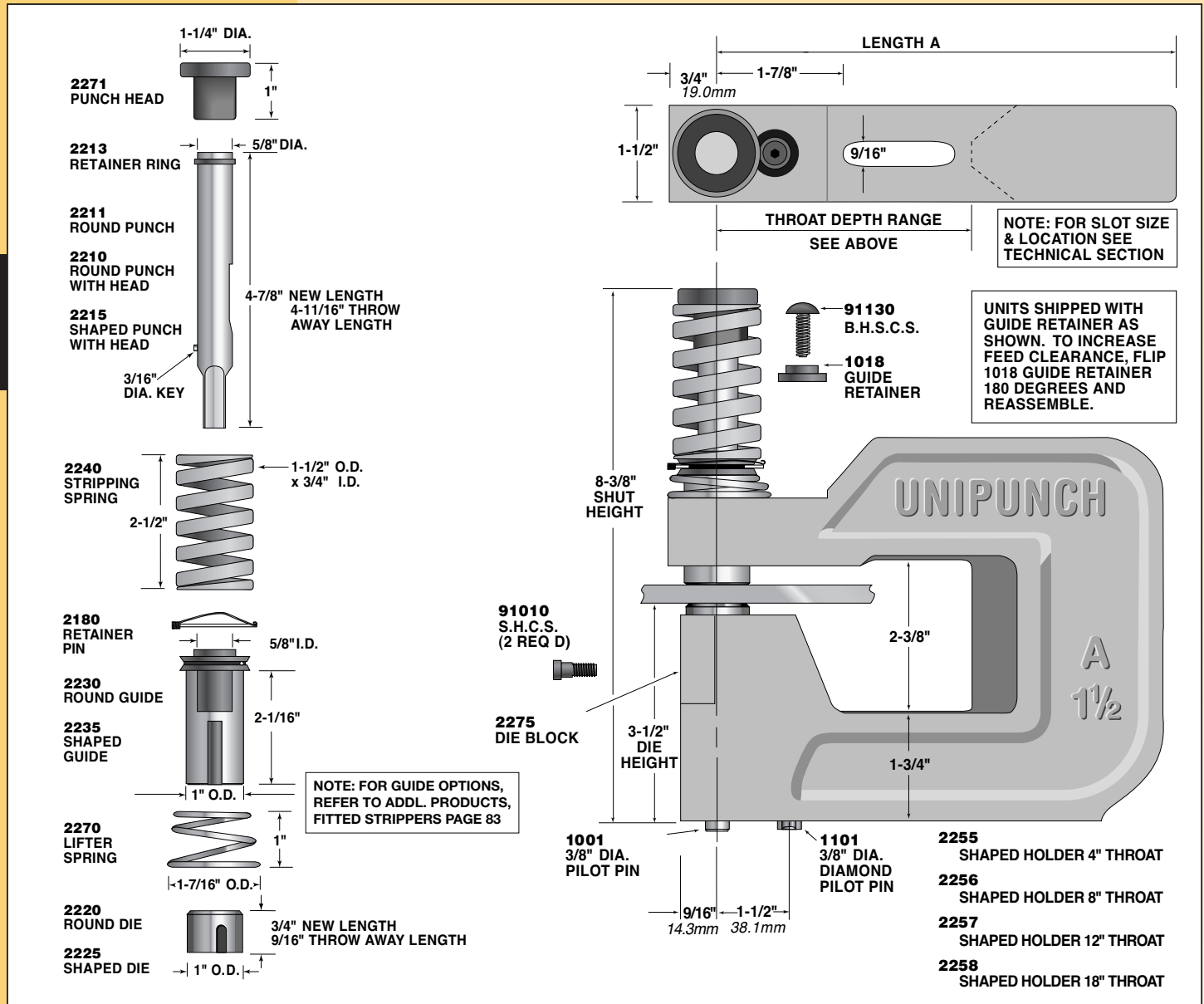

A SERIES

SPECIFICATIONS & OPERATING INSTRUCTIONS

OPERATING SHUT HEIGHT:	8-3/8" (212.7mm)
MIN. SHUT HEIGHT:	8-3/16" (208.0mm)
UNIT OPEN HEIGHT:	9-1/8" (231.8mm)
DIE HEIGHT:	3-1/2" (88.9mm)
MATERIAL FEED CLEARANCE:	7/16" (11.1mm)
MAX. MATERIAL THICKNESS (MILD STEEL):	1/4" (6.4mm)

MIN. DIE CLEARANCE:	.006" (.15mm)
MAX. PUNCH DIAMETER:	.8750" (22.22mm)
MIN. PUNCH DIAMETER:	.1875" (4.76mm)
MAX. SQUARE:	.618" (15.69mm)
MIN. SHAPE DIMENSION:	.1250" (3.18mm)
MAX. MATERIAL THICKNESS (STAINLESS STEEL):	3/32" (2.4mm)

A-2[™]

50.8mm width

	ROUND UNITS		*SHAPED UNITS		COMMON DIMS.		
	Model No.	Part No.	Model No.	Part No.	Throat Depth	Length A	Shipping Weight
BASE UNITS LESS PUNCH & DIE	4A-2-LPD	2303-LPD	4SA-2-LPD	2305-LPD	4"	7"	18.5 lbs.
	8A-2-LPD	2300-LPD	8SA-2-LPD	2306-LPD	8"	11"	22.5 lbs.
	12A-2-LPD	2301-LPD	12SA-2-LPD	2307-LPD	12"	15"	27.5 lbs.
COMPLETE UNITS (Includes Punch & Die)	4A-2	2303	4SA-2	2305	4"	7"	19 lbs.
	8A-2	2300	8SA-2	2306	8"	11"	23 lbs.
	12A-2	2301	12SA-2	2307	12"	15"	28 lbs.

*To order a shaped unit with round punch & die, add the suffix "- RPD"

KITS AND SHIMS

Shaped hole conversion kit:	7114
Key kit:	9300
Hardware kit:	9395
Punch shim:	N.A.
Die shim:	1093-12 pk. 1093-48 pk. 1/16" thk./3 max.
Upper arm kit:	9737 Round 9738 Shaped

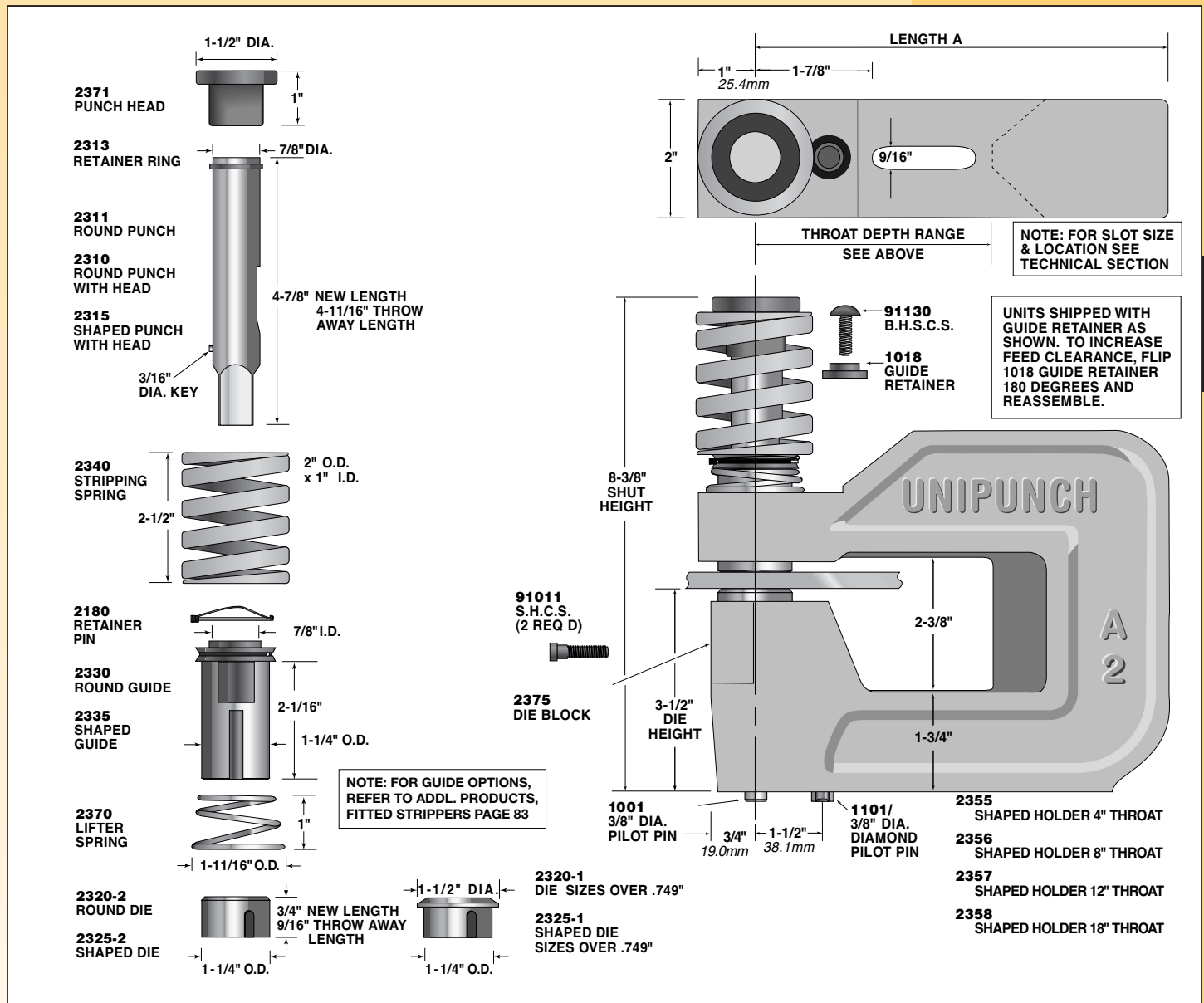

A SERIES

SPEED WITHIN REACH

UNIPUNCH

A-2 1/2"

63.5mm width

SPECIFICATIONS & OPERATING INSTRUCTIONS

OPERATING SHUT HEIGHT:	8-3/8" (212.7mm)	MIN. DIE CLEARANCE:	.006" (.15mm)
MIN. SHUT HEIGHT:	8-3/16" (208.0mm)	MAX. PUNCH DIAMETER:	1.5000" (38.10mm)
UNIT OPEN HEIGHT:	9-1/8" (231.8mm)	MIN. PUNCH DIAMETER:	.2812" (7.15mm)
DIE HEIGHT:	3-1/2" (88.9mm)	MAX. SQUARE:	1.060" (26.92mm)
MATERIAL FEED CLEARANCE:	7/16" (11.1mm)	MIN. SHAPE DIMENSION:	.1250" (3.18mm)
MAX. MATERIAL THICKNESS (MILD STEEL):	1/4" (6.4mm)	MAX. MATERIAL THICKNESS (STAINLESS STEEL):	3/32" (2.4mm)

KITS AND SHIMS

Shaped hole conversion kit:	7115
Key kit:	9300
Hardware kit:	9396
Punch shim:	1109-12 pk. 1109-48 pk. 1/16" thk./3 max
Die shim:	1094-12 pk. 1094-48 pk. 1/16" thk./3 max.
Upper arm kit:	9739 Round 9740 Shaped

	ROUND UNITS		*SHAPED UNITS		COMMON DIMS.		
	Model No.	Part No.	Model No.	Part No.	Throat Depth	Length A	Shipping Weight
BASE UNITS LESS PUNCH & DIE	4A-2 1/2-LPD	2400-LPD	4SA-2 1/2-LPD	2405-LPD	4"	7"	27.5 lbs.
	8A-2 1/2-LPD	2401-LPD	8SA-2 1/2-LPD	2406-LPD	8"	11"	33.5 lbs.
	12A-2 1/2-LPD	2402-LPD	12SA-2 1/2-LPD	2407-LPD	12"	15"	43.5 lbs.
COMPLETE UNITS (Includes Punch & Die)	4A-2 1/2	2400	4SA-2 1/2	2405	4"	7"	28 lbs.
	8A-2 1/2	2401	8SA-2 1/2	2406	8"	11"	34.5 lbs.
	12A-2 1/2	2402	12SA-2 1/2	2407	12"	15"	44.5 lbs.

*To order a shaped unit with round punch & die, add the suffix "- RPD"

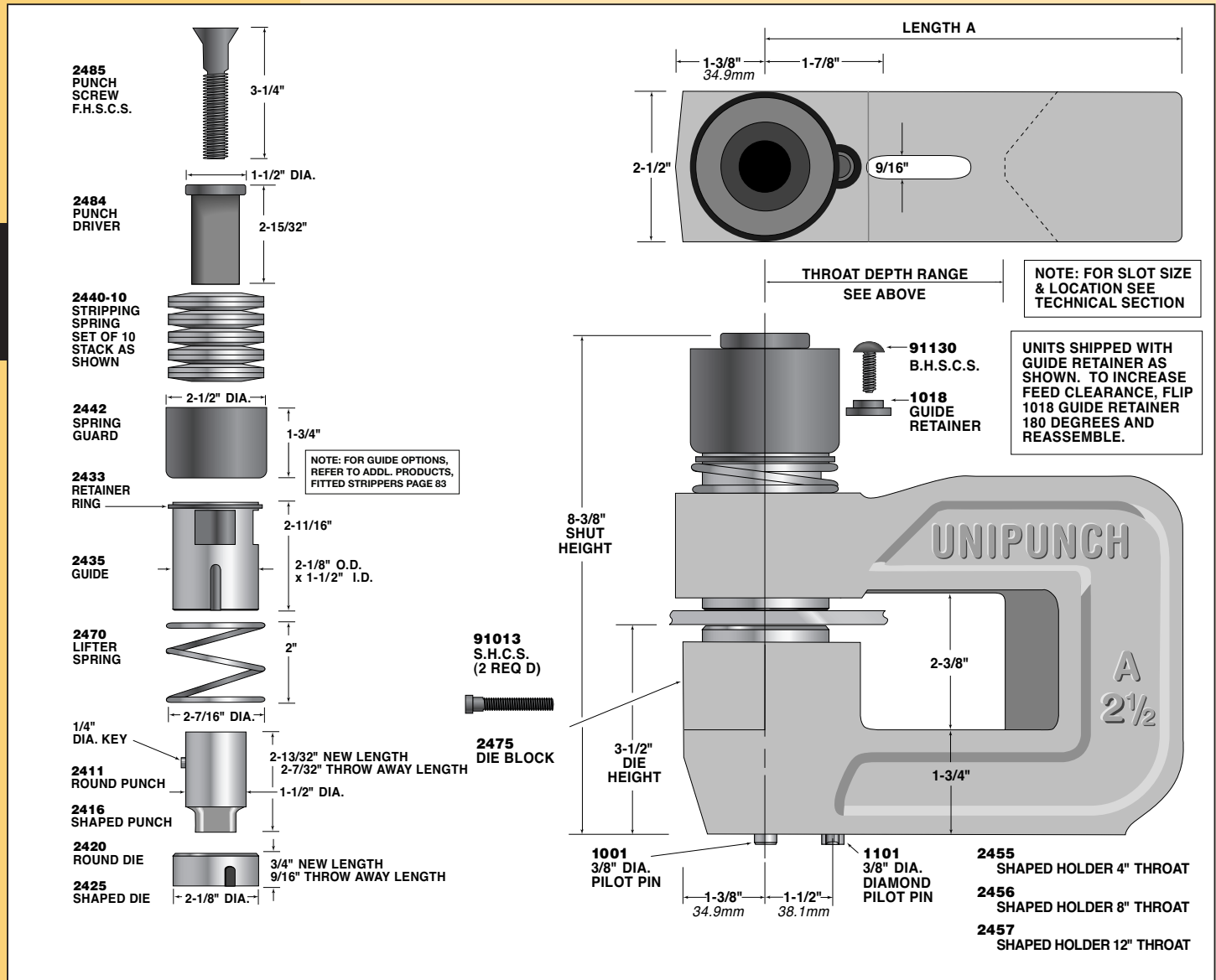

SPEED WITHIN REACH

UNIPUNCH

SPECIFICATIONS & OPERATING INSTRUCTIONS

OPERATING SHUT HEIGHT:	8-3/8" (212.7mm)	MIN. DIE CLEARANCE:	.012" (.30mm)
MIN. SHUT HEIGHT:	8-3/16" (208.0mm)	MAX. PUNCH DIAMETER:	2.0000" (50.80mm)
UNIT OPEN HEIGHT:	9-1/4" (235mm)	MIN. PUNCH DIAMETER:	.5000" (12.70mm)
DIE HEIGHT:	3-1/2" (88.9mm)	MAX. SQUARE:	1.414" (35.92mm)
MATERIAL FEED CLEARANCE:	1/2" (12.7mm)	MIN. SHAPE DIMENSION:	.1250" (3.18mm)
MAX. MATERIAL THICKNESS (MILD STEEL):	1/4" (6.4mm)	MAX. MATERIAL THICKNESS (STAINLESS STEEL):	3/32" (2.4mm)

A-3 1/2"

88.9mm width

	ROUND UNITS		*SHAPED UNITS		COMMON DIMS.		
	Model No.	Part No.	Model No.	Part No.	Throat Depth	Length A	Shipping Weight
BASE UNITS LESS PUNCH & DIE	8A-3 1/2-LPD	2900-LPD	8SA-3 1/2-LPD	2905-LPD	8"	11 3/4"	44 lbs.
	12A-3 1/2-LPD	2901-LPD	12SA-3 1/2-LPD	2906-LPD	12"	15 3/4"	54 lbs.
COMPLETE UNITS (Includes Punch & Die)	8A-3 1/2	2900	8SA-3 1/2	2905	8"	11 3/4"	45.5 lbs.
	12A-3 1/2	2901	12SA-3 1/2	2906	12"	15 3/4"	55.5 lbs.

*To order a shaped unit with round punch & die, add the suffix "- RPD"

KITS AND SHIMS

All A-3 1/2 units furnished with Shaped Driver and Guide

Key kit:	9301
Hardware kit:	9354
Punch shim:	1109-12 pk. 1109-48 pk. 1/16" thk./3 max.
Die shim:	1095 1/16" thk./1 max.

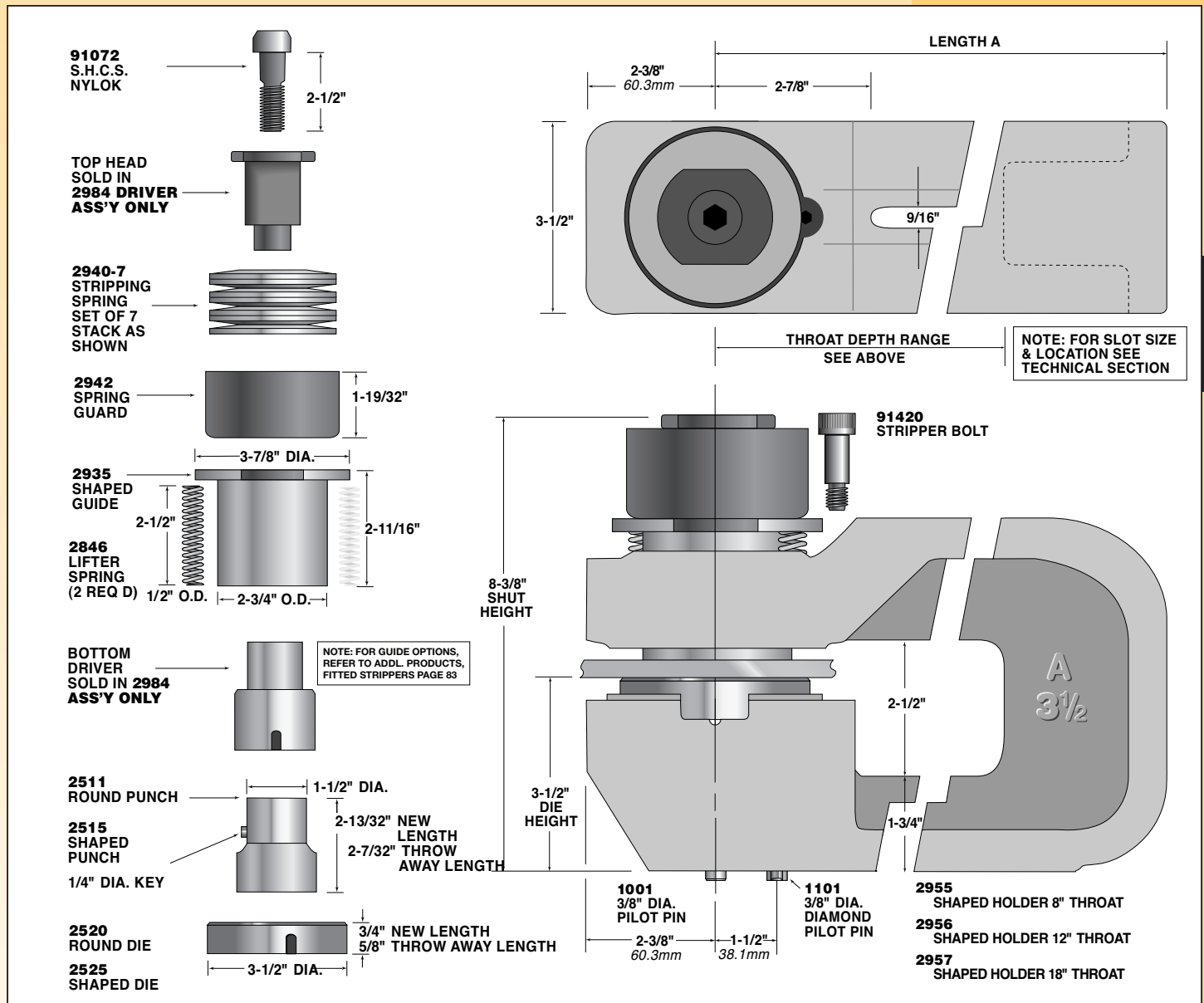

A SERIES

SPEED WITHIN REACH

UNIPUNCH

A-5 1/2"

139.7mm width

SPECIFICATIONS & OPERATING INSTRUCTIONS

OPERATING SHUT HEIGHT:	8-3/8" (212.7mm)
MIN. SHUT HEIGHT:	8-3/16" (208.0mm)
UNIT OPEN HEIGHT:	9-1/4" (235 mm)
DIE HEIGHT:	3-1/2" (88.9mm)
MATERIAL FEED CLEARANCE:	7/16" (11.1mm)
MAX. MATERIAL THICKNESS (MILD STEEL):	1/4" (6.4mm)

MIN. DIE CLEARANCE:	.012" (.30 mm)
MAX. PUNCH DIAMETER:	3.0000" (76.20mm)
MIN. PUNCH DIAMETER:	1.0000" (25.40mm)
MAX. SQUARE:	2.121" (53.87mm)
MIN. SHAPE DIMENSION:	.1875" (4.76mm)
MAX. MATERIAL THICKNESS (STAINLESS STEEL):	3/32" (2.4mm)

KITS AND SHIMS

All A-5 1/2 units furnished with Shaped Driver and Guide

Key kit:	9302
Hardware kit:	9354
Punch shim:	1109-12 pk. 1109-48 pk. 1/16" thk./3 max.
Die shim:	1128 1/16" thk./2 max.

	ROUND UNITS		*SHAPED UNITS		COMMON DIMS.		
	Model No.	Part No.	Model No.	Part No.	Throat Depth	Length A	Shipping Weight
BASE UNITS	8A-5 1/2-LPD	2830-LPD	8SA-5 1/2-LPD	2835-LPD	8 1/4"	12 1/4"	82 lbs.
LESS PUNCH & DIE	12A-5 1/2-LPD	2831-LPD	12SA-5 1/2-LPD	2836-LPD	12 1/4"	16 1/4"	94 lbs.
COMPLETE UNITS	8A-5 1/2	2830	8SA-5 1/2	2835	8 1/4"	12 1/4"	84 lbs.
(Includes Punch & Die)	12A-5 1/2	2831	12SA-5 1/2	2836	12 1/4"	16 1/4"	96 lbs.

*To order a shaped unit with round punch & die, add the suffix "- RPD"

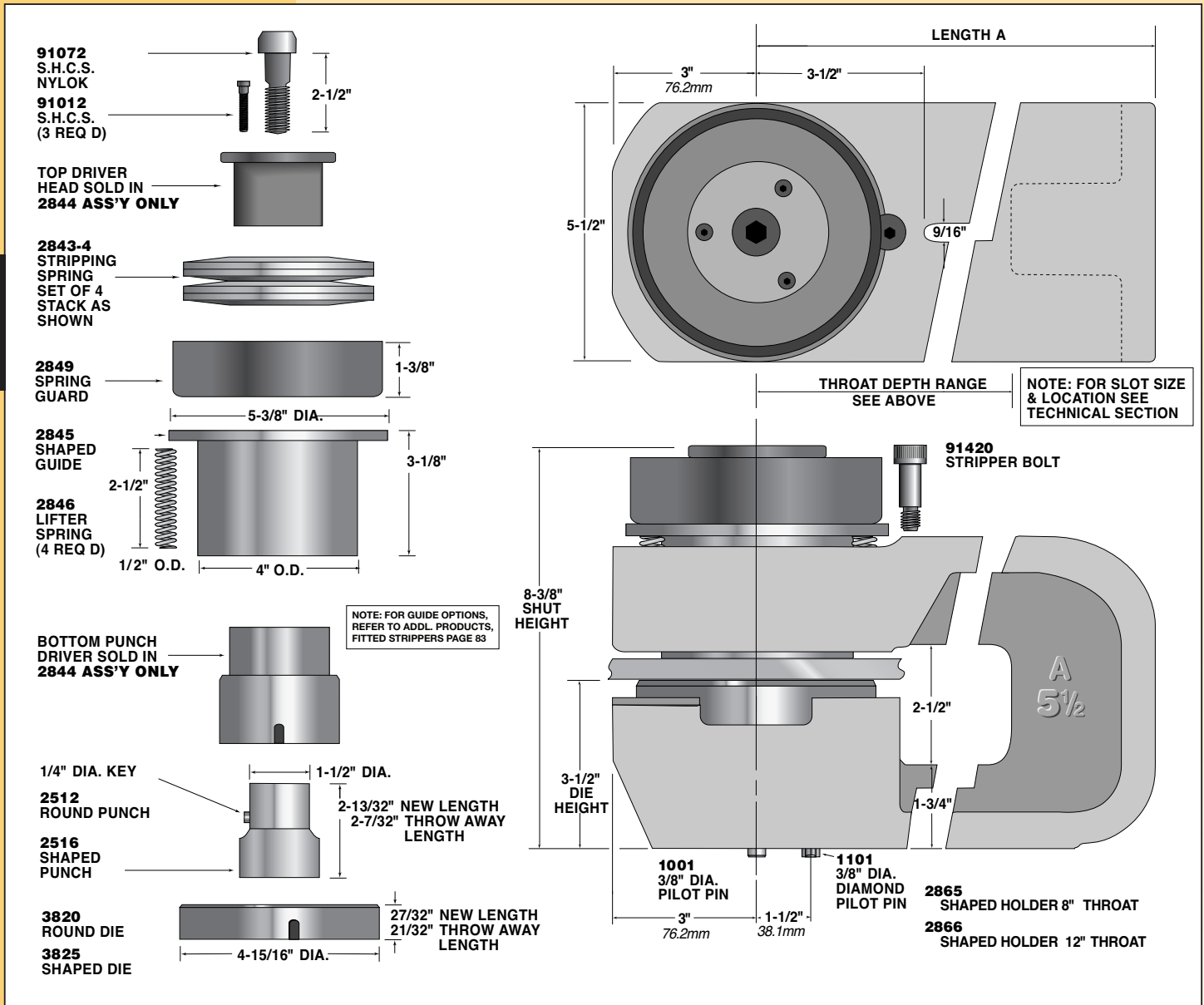

SPEED WITHIN REACH

UNIPUNCH

SPECIFICATIONS & OPERATING INSTRUCTIONS

OPERATING SHUT HEIGHT:	8-3/8" (212.7mm)
MIN. SHUT HEIGHT:	8-3/16" (208.0mm)
UNIT OPEN HEIGHT:	9" (228.6mm)
DIE HEIGHT:	3-1/2" (88.9mm)
MATERIAL FEED CLEARANCE:	7/16" (11.1mm)
MIN. DIE CLEARANCE:	.012" (50.8mm)
MAX. MAT. THK. (M.S.):	1/4" (6.4mm)

MAX. PUNCH DIAMETER:	5.000" (127.00mm) in 10 GA./ .134" (3.40mm) M.S. 4.500" (114.30mm) in 3/16" (4.76mm) M.S. 3.500" (88.90mm) in 1/4" (6.4mm) M.S.
MIN. PUNCH DIAMETER:	2.000" (50.80mm)
MAX. SQUARE:	3.535" (89.79mm)
MIN. SHAPE DIMENSION:	.250" (6.35mm)
MAX. MAT. THK. (S.S.):	3/32" (2.4mm)

A-8"

203.2mm width

	ROUND UNITS		*SHAPED UNITS		COMMON DIMS.		
	Model No.	Part No.	Model No.	Part No.	Throat Depth	Length A	Shipping Weight
BASE UNITS LESS PUNCH & DIE	12A-8-LPD	1401-LPD	12SA-8-LPD	1406-LPD	12 1/2"	17 1/2"	212 lbs.
COMPLETE UNITS (Includes Punch & Die)	12A-8	1401	12SA-8	1406	12 1/2"	17 1/2"	216 lbs.

*To order a shaped unit with round punch & die, add the suffix "- RPD"

KITS AND SHIMS

All A-8 units furnished with Shaped Driver and Guide

Key kit:	9338
Hardware kit:	9399
Punch shim:	N.A.
Die shim:	N.A.

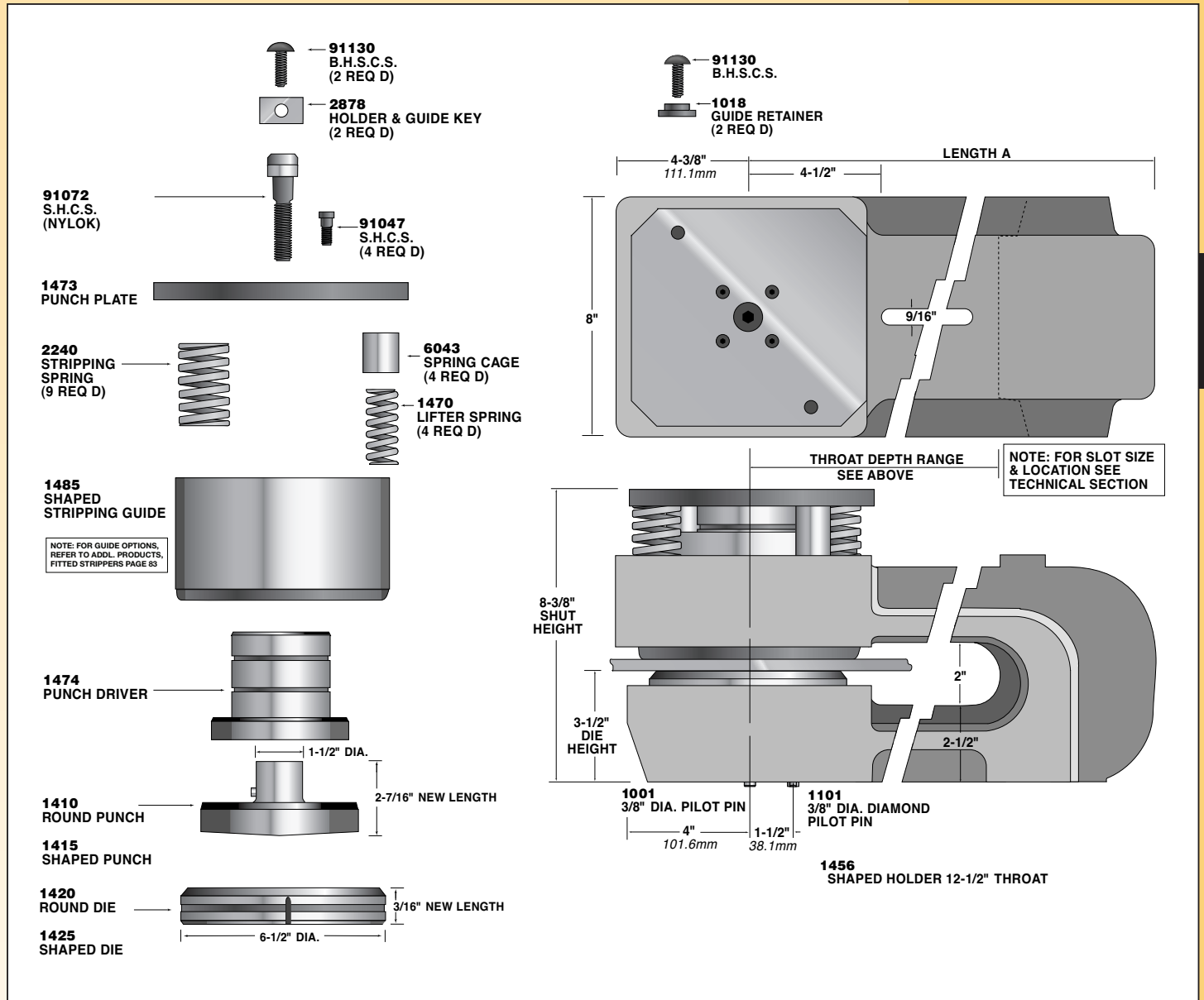

A SERIES

SPEED WITHIN REACH

UNIPUNCH

AJ-1[®]

25.4mm width

SPECIFICATIONS & OPERATING INSTRUCTIONS

OPERATING SHUT HEIGHT:	8-3/8" (212.7mm)
MIN. SHUT HEIGHT:	8-3/16" (208.0mm)
UNIT OPEN HEIGHT:	9-1/8" (231.8mm)
DIE HEIGHT:	3-1/2" (88.9mm)
MATERIAL FEED CLEARANCE:	7/16" (11.1mm)
MIN. DIE CLEARANCE:	.006" (.15mm)
MAX. MAT. THK. (M.S.):	1/4" (6.4mm)

MAX. PUNCH DIAMETER:	.3125" (7.94mm) in 1/4" (6.4mm) M.S. .4375" (11.11mm) in 1/8" (3.18mm) S.S.
MIN. PUNCH DIAMETER:	.0937" (2.38mm)
MAX. SQUARE:	.309" (7.85mm)
MIN. SHAPE DIMENSION:	.0937" (2.38mm)
MAX. MAT. THK. (S.S.):	1/8" (3.18mm)

KITS AND SHIMS

Shaped hole conversion kit:	7121
Key kit:	9322
Hardware kit:	9377
Punch shim:	N.A.
Pedestal/Adapter Die shim:	1117-12 pk. 1117-48 pk. 1/16" thk./3 max.
Upper arm kit:	9731 Round 9732 Shaped

*To order shaped unit w/ round punch & die, add suffix "-RPD".

	ROUND UNITS		*SHAPED UNITS		COMMON DIMS.		
	Model No.	Part No.	Model No.	Part No.	Throat Depth	Length A	Shipping Weight
BASE UNITS LESS PUNCH, DIE AND DIE ADAPTER	4AJ-1P-LPD	1400P-LPD	4SAJ-1P-LPD	14005P-LPD	4"	7"	7.5 lbs.
	8AJ-1P-LPD	14001P-LPD	8SAJ-1P-LPD	14006P-LPD	8"	11"	9.5 lbs.
	12AJ-1P-LPD	14002P-LPD	12SAJ-1P-LPD	14007P-LPD	12"	15"	13 lbs.
BASE UNITS LESS PUNCH & DIE (Includes Die Adapter)	4AJ-1A-LPD	14000A-LPD	4SAJ-1A-LPD	14005A-LPD	4"	7"	8.0 lbs.
	8AJ-1A-LPD	14001A-LPD	8SAJ-1A-LPD	14006A-LPD	8"	11"	10.0 lbs.
	12AJ-1A-LPD	14002A-LPD	12SAJ-1A-LPD	14007A-LPD	12"	15"	13.5 lbs.
COMPLETE UNITS WITH DIE ADAPTER (Includes Punch & Die)	4AJ-1 A	14000A	4SAJ-1 A	14005A	4"	7"	8.5 lbs.
	8AJ-1 A	14001A	8SAJ-1 A	14006A	8"	11"	10.5 lbs.
	12AJ-1 A	14002A	12SAJ-1 A	14007A	12"	15"	14 lbs.
COMPLETE UNITS WITH PEDESTAL DIE (Includes Punch)	4AJ-1 P	14000P	4SAJ-1 P	14005P	4"	7"	8.5 lbs.
	8AJ-1 P	14001P	8SAJ-1 P	14006P	8"	11"	10.5 lbs.
	12AJ-1 P	14002P	12SAJ-1 P	14007P	12"	15"	14 lbs.

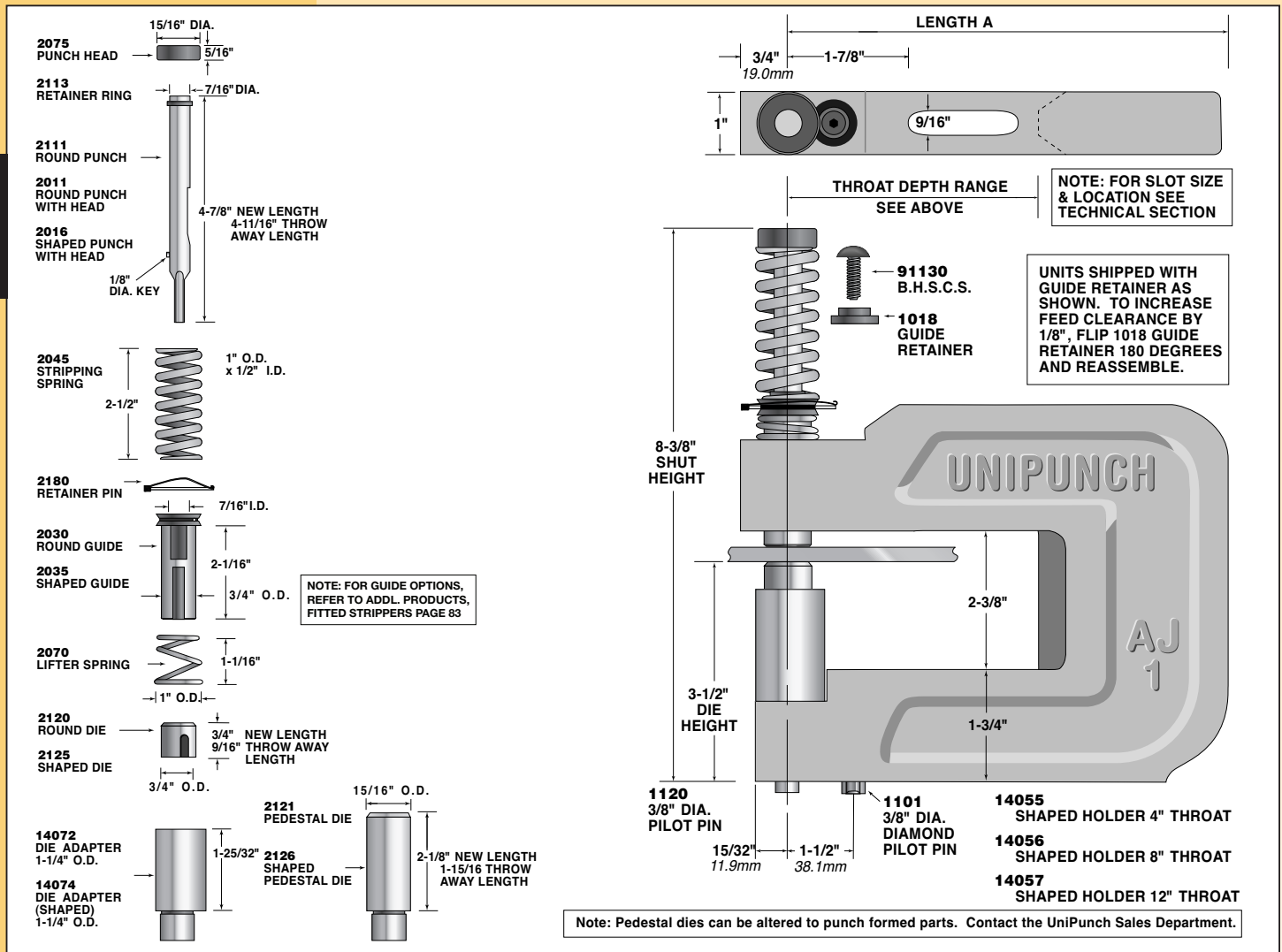

SPEED WITHIN REACH

UNIPUNCH

SPECIFICATIONS & OPERATING INSTRUCTIONS

OPERATING SHUT HEIGHT:	8-3/8" (212.7mm)
MIN. SHUT HEIGHT:	8-3/16" (208.0mm)
UNIT OPEN HEIGHT:	9-1/8" (231.8mm)
DIE HEIGHT:	3-1/2" (88.9mm)
MATERIAL FEED CLEARANCE:	7/16" (11.1mm)
MAX. MATERIAL THICKNESS (MILD STEEL):	1/4" (6.4mm)

MIN. DIE CLEARANCE:	.006" (.15mm)
MAX. PUNCH DIAMETER:	.4375" (11.11mm)
MIN. PUNCH DIAMETER:	.0937" (2.38mm)
MAX. SQUARE:	.309" (7.85mm)
MIN. SHAPE DIMENSION:	.0937" (2.38mm)
MAX. MATERIAL THICKNESS (STAINLESS STEEL):	1/8" (3.18mm)

AJ-1 1/4"

31.8mm width

	ROUND UNITS		*SHAPED UNITS		COMMON DIMS.		
	Model No.	Part No.	Model No.	Part No.	Throat Depth	Length A	Shipping Weight
BASE UNITS LESS PUNCH, DIE AND DIE ADAPTER	4A J-1 1/4P-LPD	14100P-LPD	4SAJ-1 1/4P-LPD	14105P-LPD	4"	7"	9 lbs.
	8A J-1 1/4P-LPD	14101P-LPD	8SAJ-1 1/4P-LPD	14106P-LPD	8"	11"	10.5 lbs.
	12A J-1 1/4P-LPD	14102P-LPD	12SAJ-1 1/4P-LPD	14107P-LPD	12"	15"	15 lbs.
BASE UNITS LESS PUNCH & DIE (Includes Die Adapter)	4A J-1 1/4A-LPD	14100A-LPD	4SAJ-1 1/4A-LPD	14105A-LPD	4"	7"	9.5 lbs.
	8A J-1 1/4A-LPD	14101A-LPD	8SAJ-1 1/4A-LPD	14106A-LPD	8"	11"	11.0 lbs.
	12A J-1 1/4A-LPD	14102A-LPD	12SAJ-1 1/4A-LPD	14107A-LPD	12"	15"	16.5 lbs.
COMPLETE UNITS WITH DIE ADAPTER (Includes Punch & Die)	4A J-1 1/4 A	14100A	4SAJ-1 1/4 A	14105A	4"	7"	10 lbs.
	8A J-1 1/4 A	14101A	8SAJ-1 1/4 A	14106A	8"	11"	11.5 lbs.
	12A J-1 1/4 A	14102A	12SAJ-1 1/4 A	14107A	12"	15"	16 lbs.
COMPLETE UNITS WITH PEDESTAL DIE (Includes Punch)	4A J-1 1/4 P	14100P	4SAJ-1 1/4 P	14105P	4"	7"	10 lbs.
	8A J-1 1/4 P	14101P	8SAJ-1 1/4 P	14106P	8"	11"	11.5 lbs.
	12A J-1 1/4 P	14102P	12SAJ-1 1/4 P	14107P	12"	15"	16 lbs.

KITS AND SHIMS

Shaped hole conversion kit:	7122
Key kit:	9322
Hardware kit:	9377
Punch shim:	N.A.
Pedestal/Adapter Die shim:	1117-12 1117-48 1/16" thk./3 max.
Upper arm kit:	9733 Round 9734 Shaped

*To order shaped unit w/ round punch & die, add suffix "-RPD".

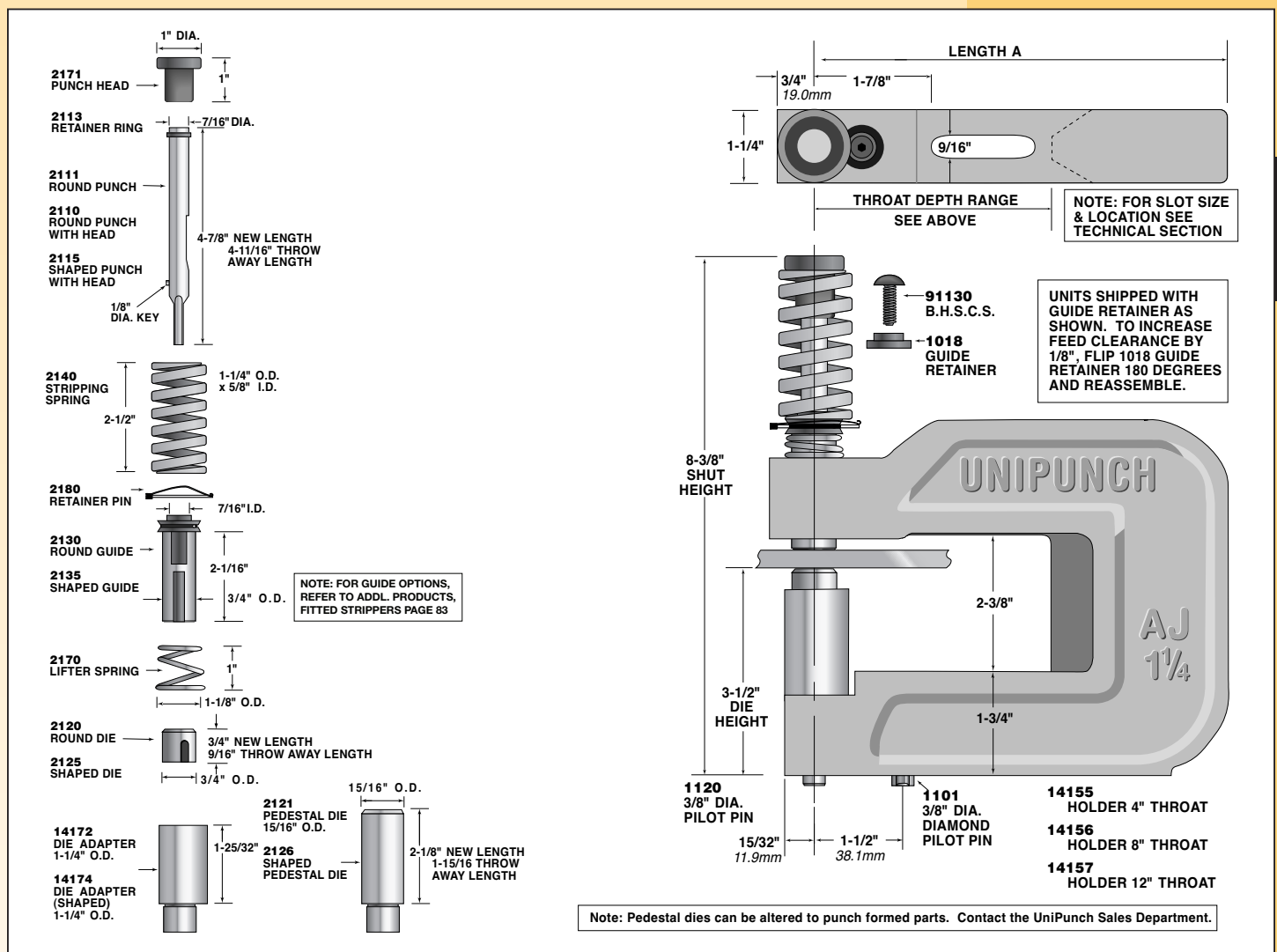

A SERIES

AJ-1 1/2"

38.1mm width

KITS AND SHIMS

Shaped hole conversion kit:	7123
Key kit:	9322
Hardware kit:	9377
Punch shim:	N.A.
Pedestal/Adapter Die shim:	1118-12 pk. 1118-48 pk. 1/16" thk./3 max.
Upper arm kit:	9735 Round 9736 Shaped

*To order shaped unit w/ round punch & die, add suffix "-RPD".

SPECIFICATIONS & OPERATING INSTRUCTIONS

OPERATING SHUT HEIGHT:	8-3/8" (212.7mm)	MIN. DIE CLEARANCE:	.006" (.15 mm)
MIN. SHUT HEIGHT:	8-3/16" (208.0mm)	MAX. PUNCH DIAMETER:	.6250" (15.87mm)
UNIT OPEN HEIGHT:	9-1/8" (231.8mm)	MIN. PUNCH DIAMETER:	.1250" (3.18mm)
DIE HEIGHT:	3-1/2" (88.9mm)	MAX. SQUARE:	.441" (11.20mm)
MATERIAL FEED CLEARANCE:	7/16" (11.1mm)	MIN. SHAPE DIMENSION:	.0937" (2.38mm)
MAX. MATERIAL THICKNESS (MILD STEEL):	1/4" (6.4mm)	MAX. MATERIAL THICKNESS (STAINLESS STEEL):	1/8" (3.18mm)

	ROUND UNITS		*SHAPED UNITS		COMMON DIMS.		
	Model No.	Part No.	Model No.	Part No.	Throat Depth	Length A	Shipping Weight
BASE UNITS LESS PUNCH, DIE AND DIE ADAPTER	4AJ-1 1/2P-LPD	14200P-LPD	4SAJ-1 1/2P-LPD	14205P-LPD	4"	7"	13 lbs.
	8AJ-1 1/2P-LPD	14201P-LPD	8SAJ-1 1/2P-LPD	14206P-LPD	8"	11"	16 lbs.
	12AJ-1 1/2P-LPD	14202P-LPD	12SAJ-1 1/2P-LPD	14207P-LPD	12"	15"	19 lbs.
BASE UNITS LESS PUNCH & DIE (Includes Die Adapter)	4AJ-1 1/2A-LPD	14200A-LPD	4SAJ-1 1/2A-LPD	14205A-LPD	4"	7"	13.5 lbs.
	8AJ-1 1/2A-LPD	14201A-LPD	8SAJ-1 1/2A-LPD	14206A-LPD	8"	11"	16.5 lbs.
	12AJ-1 1/2A-LPD	14202A-LPD	12SAJ-1 1/2A-LPD	14207A-LPD	12"	15"	19.5 lbs.
COMPLETE UNITS WITH DIE ADAPTER (Includes Punch & Die)	4AJ-1 1/2 A	14200A	4SAJ-1 1/2 A	14205A	4"	7"	14 lbs.
	8AJ-1 1/2 A	14201A	8SAJ-1 1/2 A	14206A	8"	11"	17 lbs.
	12AJ-1 1/2 A	14202A	12SAJ-1 1/2 A	14207A	12"	15"	20 lbs.
COMPLETE UNITS WITH PEDESTAL DIE (Includes Punch)	4AJ-1 1/2 P	14200P	4SAJ-1 1/2 P	14205P	4"	7"	14 lbs.
	8AJ-1 1/2 P	14201P	8SAJ-1 1/2 P	14206P	8"	11"	17 lbs.
	12AJ-1 1/2 P	14202P	12SAJ-1 1/2 P	14207P	12"	15"	20 lbs.

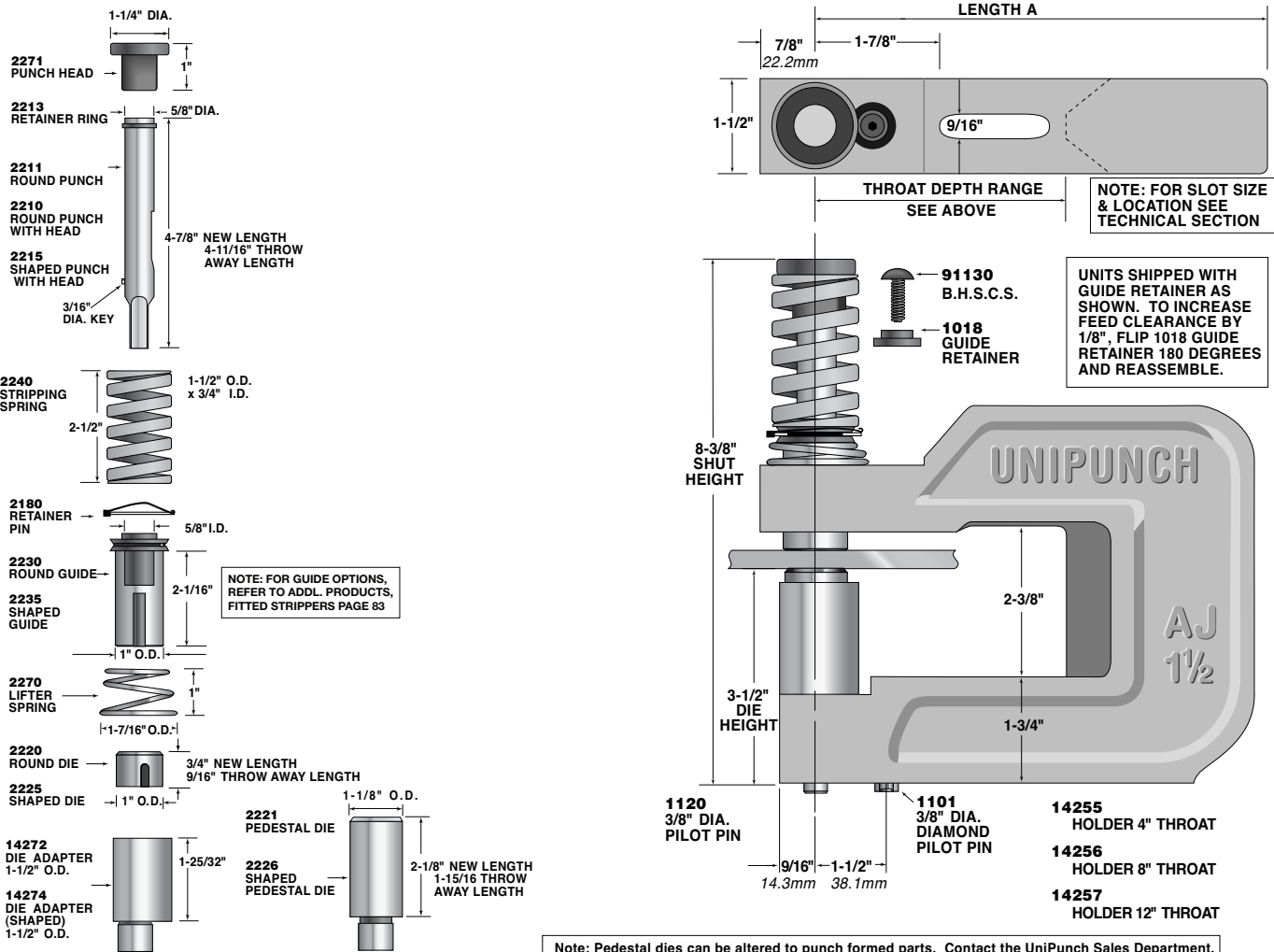

A SERIES

SPEED WITHIN REACH

UNIPUNCH

SPECIFICATIONS & OPERATING INSTRUCTIONS

OPERATING SHUT HEIGHT:	8-3/8" (212.7mm)
MIN. SHUT HEIGHT:	8-3/16" (208.0mm)
UNIT OPEN HEIGHT:	9-1/8" (231.8mm)
DIE HEIGHT:	3-1/2" (88.9mm)
MATERIAL FEED CLEARANCE:	7/16" (11.1mm)
MAX. MATERIAL THICKNESS (MILD STEEL):	1/4" (6.4mm)

MIN. DIE CLEARANCE:	.006" (.15mm)
MAX. PUNCH DIAMETER:	.8750" (22.22mm)
MIN. PUNCH DIAMETER:	.1875" (4.76mm)
MAX. SQUARE:	.618" (15.69mm)
MIN. SHAPE DIMENSION:	.1250" (3.18mm)
MAX. MATERIAL THICKNESS (STAINLESS STEEL):	1/8" (3.18mm)

AJ-2[™]

50.8mm width

	ROUND UNITS		*SHAPED UNITS		COMMON DIMS.		
	Model No.	Part No.	Model No.	Part No.	Throat Depth	Length A	Shipping Weight
BASE UNITS LESS PUNCH, DIE AND DIE ADAPTER	4AJ-2P-LPD	14300P-LPD	4SAJ-2P-LPD	14305P-LPD	4"	7"	18 lbs.
	8AJ-2P-LPD	14301P-LPD	8SAJ-2P-LPD	14306P-LPD	8"	11"	22 lbs.
	12AJ-2P-LPD	14302P-LPD	12SAJ-2P-LPD	14307P-LPD	12"	15"	27 lbs.
BASE UNITS LESS PUNCH & DIE (Includes Die Adapter)	4AJ-2A-LPD	14300A-LPD	4SAJ-2A-LPD	14305A-LPD	4"	7"	18.5 lbs.
	8AJ-2A-LPD	14301A-LPD	8SAJ-2A-LPD	14306A-LPD	8"	11"	22.5 lbs.
	12AJ-2A-LPD	14302A-LPD	12SAJ-2A-LPD	14307A-LPD	12"	15"	27.5 lbs.
COMPLETE UNITS WITH DIE ADAPTER (Includes Punch & Die)	4AJ-2 A	14300A	4SAJ-2 A	14305A	4"	7"	19 lbs.
	8AJ-2 A	14301A	8SAJ-2 A	14306A	8"	11"	23 lbs.
	12AJ-2 A	14302A	12SAJ-2 A	14307A	12"	15"	28 lbs.
COMPLETE UNITS WITH PEDESTAL DIE (Includes Punch)	4AJ-2 P	14300P	4SAJ-2 P	14305P	4"	7"	19 lbs.
	8AJ-2 P	14301P	8SAJ-2 P	14306P	8"	11"	23 lbs.
	12AJ-2 P	14302P	12SAJ-2 P	14307P	12"	15"	28 lbs.

KITS AND SHIMS

Shaped hole conversion kit:	7124
Key kit:	9322
Hardware kit:	9377
Punch shim:	N.A.
Pedestal/Adapter Die shim:	1119-12 pk. 1119-48 pk. 1/16" thk./3 max.
Upper arm kit:	9737 Round 9738 Shaped

*To order shaped unit w/ round punch & die, add suffix "-RPD".

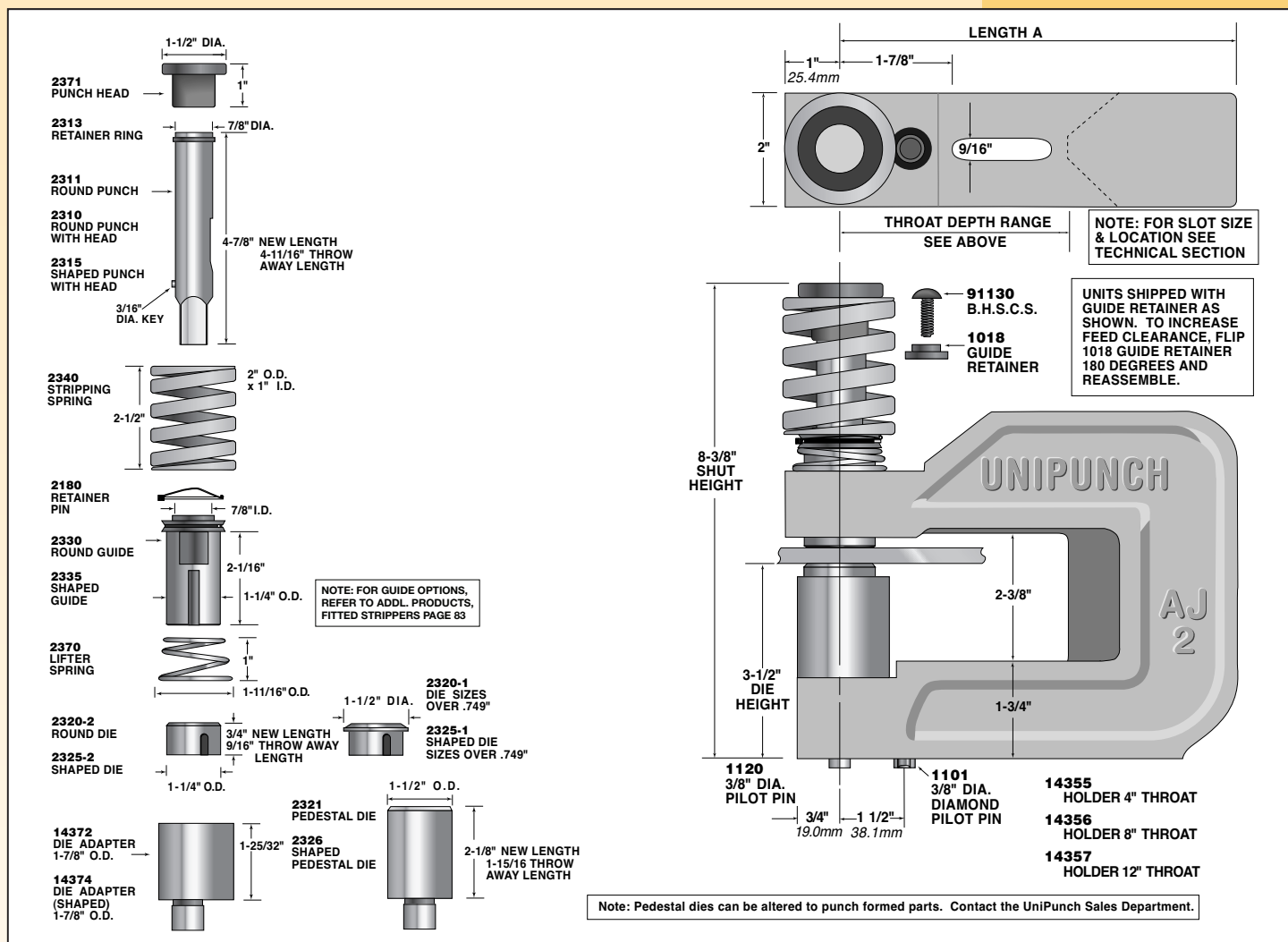

A SERIES

SPEED WITHIN REACH

UNIPUNCH

AJ-2 1/2"

63.5mm width

SPECIFICATIONS & OPERATING INSTRUCTIONS

OPERATING SHUT HEIGHT:	8-3/8" (212.7mm)	MIN. DIE CLEARANCE:	.006" (.15mm)
MIN. SHUT HEIGHT:	8-3/16" (208.0mm)	MAX. PUNCH DIAMETER:	1.250" (31.75mm)
UNIT OPEN HEIGHT:	9-1/8" (231.8mm)	MIN. PUNCH DIAMETER:	.2812" (7.14mm)
DIE HEIGHT:	3-1/2" (88.9mm)	MAX. SQUARE:	.883" (22.43mm)
MATERIAL FEED CLEARANCE:	7/16" (11.1mm)	MIN. SHAPE DIMENSION:	.1250" (3.18mm)
MAX. MATERIAL THICKNESS (MILD STEEL):	1/4" (6.4mm)	MAX. MATERIAL THICKNESS (STAINLESS STEEL):	1/8" (3.18mm)

KITS AND SHIMS

Shaped hole conversion kit:	7125
Key kit:	9323
Hardware kit:	9357
Punch shim:	1109-12 pk. 1109-48 pk. 1/16" thk./3 max.
Upper arm kit:	9739 Round 9740 Shaped

	ROUND UNITS		*SHAPED UNITS		COMMON DIMS.		
	Model No.	Part No.	Model No.	Part No.	Throat Depth	Length A	Shipping Weight
BASE UNITS LESS PUNCH & DIE	8AJ-2 1/2 P-LPD	14401P-LPD	8SAJ-2 1/2 P-LPD	14406P-LPD	8"	11"	31.5 lbs.
	12AJ-2 1/2 P-LPD	14402P-LPD	12SAJ-2 1/2 P-LPD	14407P-LPD	12"	15"	41.5 lbs.
COMPLETE UNITS WITH PEDESTAL DIE (Includes Punch)	8AJ-2 1/2 P	14401P	8SAJ-2 1/2 P	14406P	8"	11"	34.5 lbs.
	12AJ-2 1/2 P	14402P	12SAJ-2 1/2 P	14407P	12"	15"	44.5 lbs.

*To order shaped unit w/ round punch & die, add suffix "-RPD".

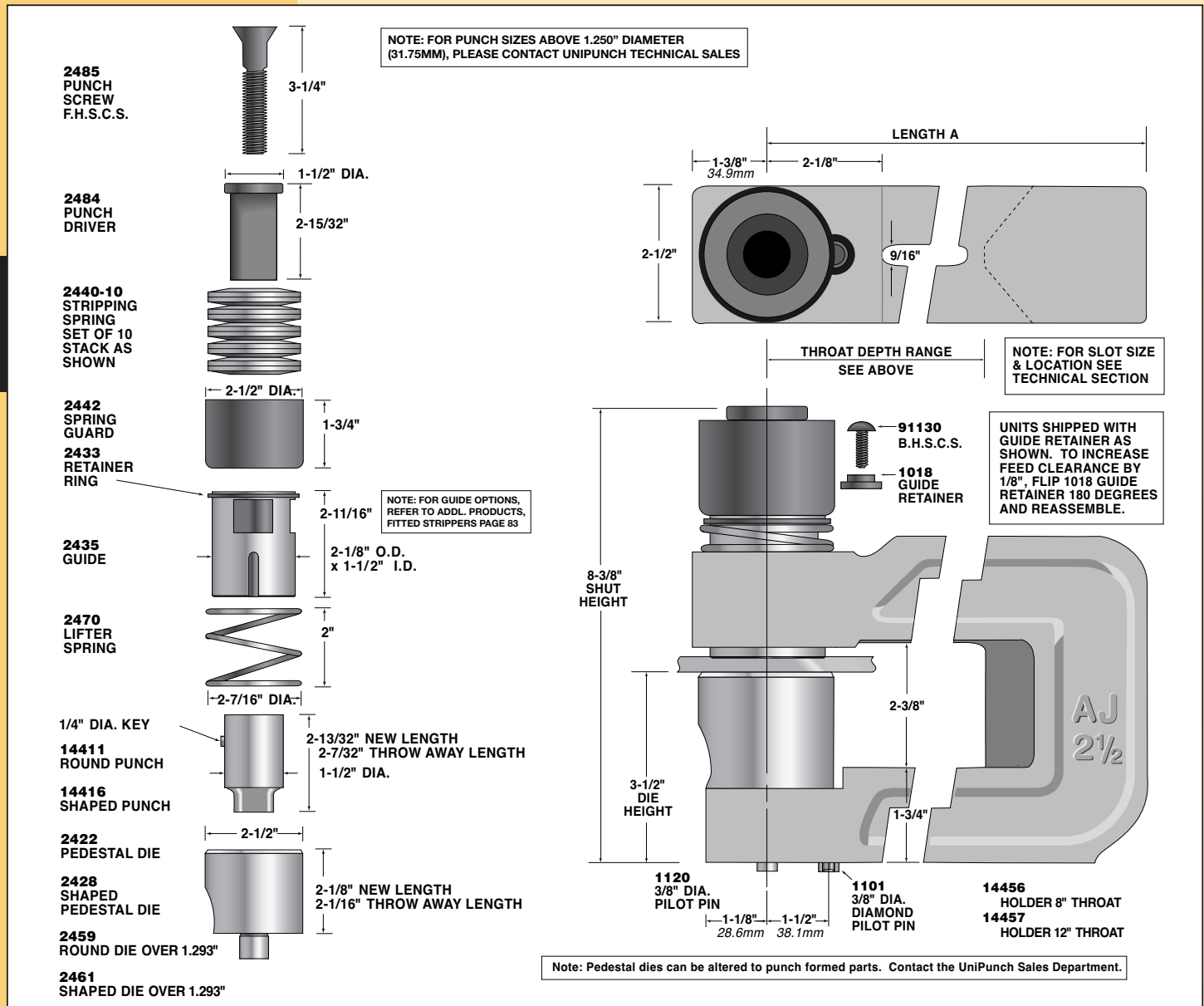

A SERIES

SPECIFICATIONS & OPERATING INSTRUCTIONS

OPERATING SHUT HEIGHT:	8-3/8" (212.7mm)
MIN. SHUT HEIGHT:	8-1/4" (209.5mm)
UNIT OPEN HEIGHT:	9-15/16" (252.4mm)
MAX. MATERIAL THICKNESS (MILD STEEL):	1/8" (3.18mm)

Available for both round and shaped holes, these units feature extra wide feed openings to allow "front feed" of channels, angles, extrusions and

DIE HEIGHT:	3-1/2" (88.9mm)
MATERIAL FEED CLEARANCE:	1-1/4" (31.8mm)
MIN. DIE CLEARANCE:	.012" (.30mm)
MAX. MATERIAL THICKNESS (STAINLESS STEEL):	1/16" (1.6mm)

other formed parts. If your particular application calls for sizes other than those shown, send your specifications for a price quotation.

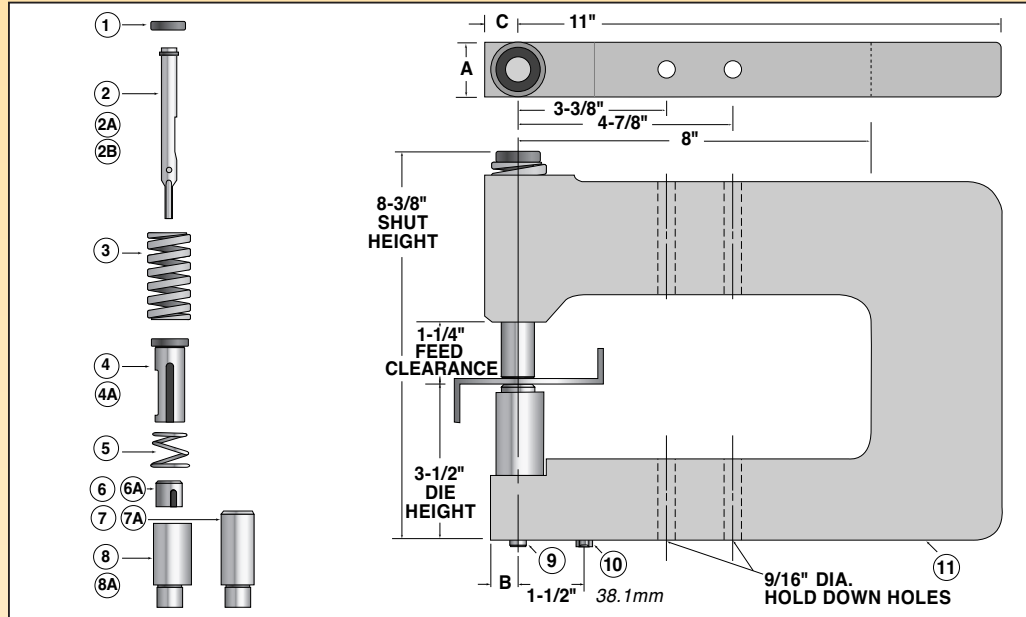

Item No.	Description	1 1/4" WIDE	1 1/2" WIDE	2 1/4" WIDE
		Part No.	Part No.	Part No.
1	Punch Head	2075	22271	22371
2	Round Punch	21111	22211	22311
2A	Round Punch with Head	21110	22210	22310
2B	Shaped Punch with Head	21115	22215	22315
3	Stripping Spring	22140	22240	22340
4	Round Guide	22130	22230	22330
4A	Shaped Guide	22135	22235	22335
5	Lifter Spring	22170	22270	22370
6	Round Die Round Die w/ Collar (over .749")	2120 —	2220 —	2320-2 2320-1
6A	Shaped Die Shaped Die w/ Collar (over .749")	2125 —	2225 —	2325-2 2325-1
7	Round Pedestal Die	2121	2221	2321
7A	Shaped Pedestal Die	2126	2226	2326
8	Die Adapter (Round)	14172	14272	14372
8A	Die Adapter (Shaped)	14174	14274	14374
9	Pilot Pin (Round)	1120	1120	1120
10	Pilot Pin (Diamond)	1101	1101	1101
11	Shaped Holder	22156	22256	22356
KITS & SHIMS	Shaped Hole Conversion Kit	7140	7141	7142
	Key Kit:	9411	9411	9413
	Hardware Kit:	9366	9366	9355
	Punch Shim:	N.A.	N.A.	N.A.
	Die Shim:	1117-12 1117-48	1118-12 1118-48	1109-12 1109-48

FCU

Feed Clearance Units

COMPLETE ROUND UNITS

STANDARD UNITS (Complete with Round Punch, Die & Adapter)			
Holder Width	Part No.	Max. Punch Dia.	Min. Punch Dia.
1 1/4"	22101A	.4375 11.1mm	.0937 2.38mm
1 1/2"	22201A	.6250 15.86mm	.1250 3.18mm
2 1/4"	22301A	.8750 22.22mm	.1875 4.76mm
OPTIONAL UNITS (Complete with Round Punch & Pedestal Die)			
Holder Width	Part No.	Max. Punch Dia.	Min. Punch Dia.
1 1/4"	22101P	.4375 11.1mm	.0937 2.38mm
1 1/2"	22201P	.6250 15.86mm	.1250 3.18mm
2 1/4"	22301P	.8750 22.22mm	.1875 4.76mm

To order a unit less punch and die, add the suffix "- LPD."

COMPLETE SHAPED UNITS

STANDARD UNITS (Complete with Shaped Punch, Die & Adapter)			
Model No.	Part No.	Max. Square	Min. Shaped Dim.
1 1/4"	22106A	.309 7.85mm	.0937 2.38mm
1 1/2"	22206A	.441 11.2mm	.0937 2.38mm
2 1/4"	22306A	.618 15.69mm	.1250 3.18mm
OPTIONAL UNITS (Complete with Shaped Punch & Pedestal Die)			
Holder Width	Part No.	Max. Square	Min. Punch Dia.
1 1/4"	22106P	.309 7.85mm	.0937 2.38mm
1 1/2"	22206P	.441 11.2mm	.0937 2.38mm
2 1/4"	22306P	.618 15.69mm	.1250 3.18mm

To order a shaped unit with round punch & die, add the suffix "- RPD."

COMMON DIMENSIONS

Holder Width	Throat Depth	A	B	C	Shipping Weight
1 1/4"	8"	1 1/4"	1 5/32"	1"	22 lbs.
1 1/2"	8"	1 1/2"	9/16"	1"	26 lbs.
2 1/4"	8"	2 1/4"	3/4"	1 3/8"	40 lbs.



SPEED WITHIN REACH
UNIPUNCH

AH-2 1/2"

63.5mm width

SPECIFICATIONS & OPERATING INSTRUCTIONS

OPERATING SHUT HEIGHT:	8-3/8" (212.7mm)	MIN. DIE CLEARANCE:	.018" (.46mm)
MIN. SHUT HEIGHT:	8-3/16" (208.0mm)	MAX. PUNCH DIAMETER:	1.000" (25.40mm)
UNIT OPEN HEIGHT:	9-3/8" (238.1mm)	MIN. PUNCH DIAMETER:	.2500" (6.35mm)
DIE HEIGHT:	3-1/2" (88.9mm)	MAX. SQUARE:	.707" (17.96mm)
MATERIAL FEED CLEARANCE:	5/8" (15.9mm)	MIN. SHAPE DIMENSION:	.1250" (3.18mm)
MAX. MATERIAL THICKNESS (MILD STEEL):	1/2" (12.7mm)	MAX. MATERIAL THICKNESS (STAINLESS STEEL):	5/32" (4.0mm)

KITS AND SHIMS

Shaped hole conversion kit:	7130
Key kit :	9306
Hardware kit:	9358
Punch shim:	1114-12 pk. 1114-48 pk. 1/16" thk./3 max.
Die shim:	1094-12 pk. 1094-48 pk. 1/16" thk./2 max.
Guide bushing installation kit:	2065

	ROUND UNITS		*SHAPED UNITS		COMMON DIMS.		
	Model No.	Part No.	Model No.	Part No.	Throat Depth	Length A	Shipping Weight
BASE ASSEMBLIES LESS PUNCH, DIE AND DIE HOLDER	8AH-2 1/2 H-LPDH	2600-LPDH	8SAH-2 1/2 LPDH	2605H-LPDH	8"	12"	40 lbs.
	12AH-2 1/2 H-LPDH	2601-LPDH	12SAH-2 1/2 LPDH	2606H-LPDH	12"	16"	47 lbs.
BASE ASSEMBLIES LESS PUNCH & DIE (Includes Die Holder)	8AH-2 1/2 H-LPD	2600-LPD	8SAH-2 1/2 H-LPD	2605H-LPD	8"	12"	42 lbs.
	12AH-2 1/2 H-LPD	2601-LPD	12SAH-2 1/2 H-LPD	2606H-LPD	12"	16"	49 lbs.
COMPLETE UNITS WITH DIE HOLDERS (Includes Punch & Die)	8AH-2 1/2 H	2600H	8SAH-2 1/2 H	2605H	8"	12"	46 lbs.
	12AH-2 1/2 H	2601H	12SAH-2 1/2 H	2606H	12"	16"	55 lbs.
COMPLETE UNITS WITH BLOCK DIES (Includes Punch)	8AH-2 1/2 BD	2600BD	8SAH-2 1/2 BD	2605BD	8"	12"	46 lbs.
	12AH-2 1/2 BD	2601BD	12SAH-2 1/2 BD	2606BD	12"	16"	56 lbs.

*To order a shaped unit with round punch & die, add the suffix "- RPD"

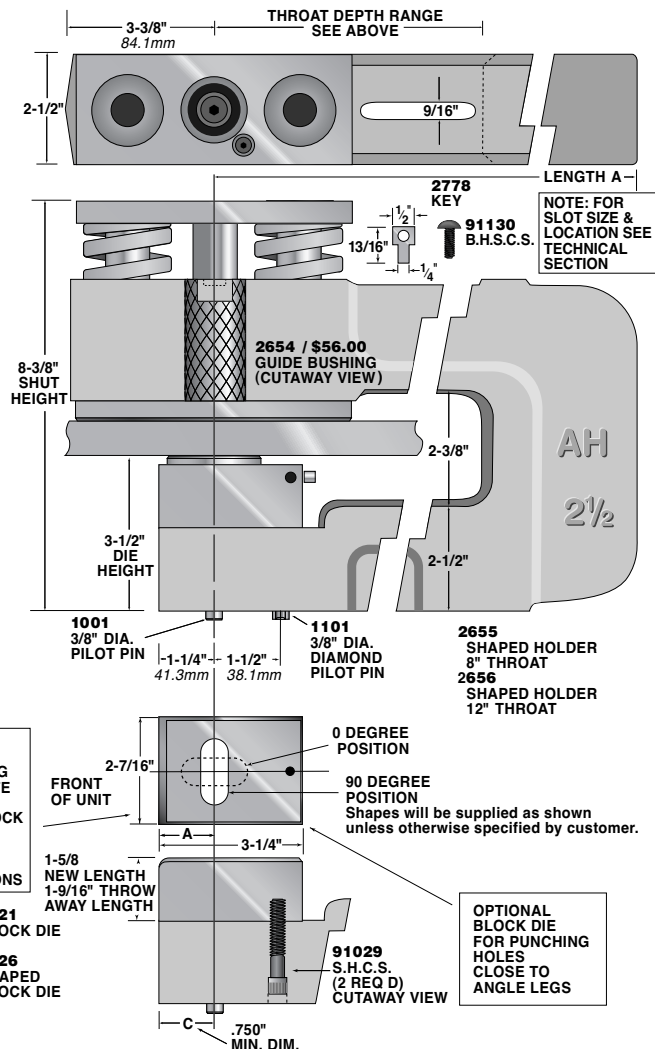
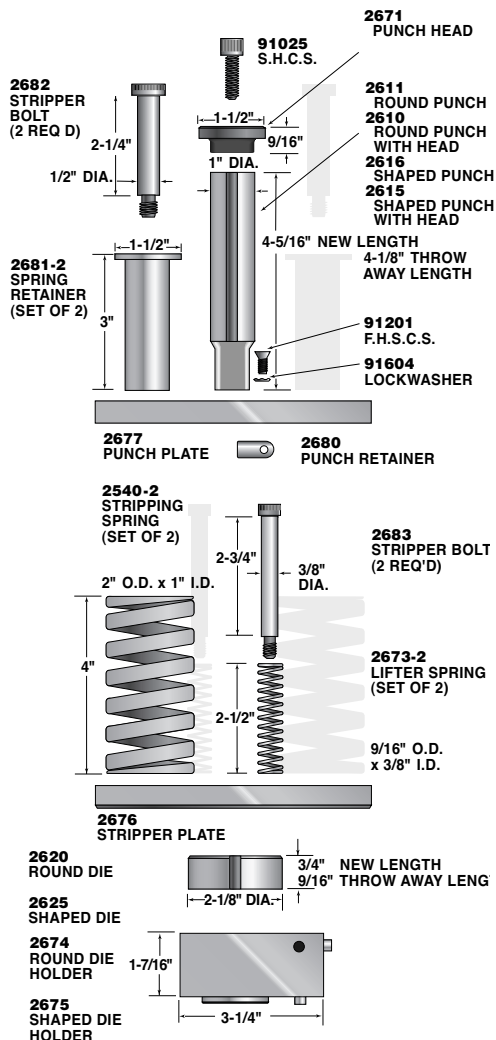

A SERIES

SPEED WITHIN REACH

UNIPUNCH

SPECIFICATIONS & OPERATING INSTRUCTIONS

OPERATING SHUT HEIGHT:	8-3/8" (212.7mm)
MIN. SHUT HEIGHT:	8-3/16" (208.0mm)
UNIT OPEN HEIGHT:	9-5/8" (244.5mm)
DIE HEIGHT:	3-1/2" (88.9mm)
MATERIAL FEED CLEARANCE:	5/8" (15.9mm)
MIN. DIE CLEARANCE:	.018" (.46mm)
MAX. MAT. THK. (M.S.):	1/2" (12.7mm)

MAX. PUNCH DIAMETER:	1.1250" (28.57mm) in 1/2" (12.7mm) M.S. 1.3750" (34.92mm) in 1/4" (6.4mm) M.S.
MIN. PUNCH DIAMETER:	.3750" (9.53mm)
MAX. SQUARE:	.972" (24.68mm)
MIN. SHAPE DIMENSION:	.1250" (3.18mm)
MAX. MAT. THK. (S.S.):	5/32" (4.00mm)

AH-3[™]

76.2mm width

	ROUND UNITS		*SHAPED UNITS		COMMON DIMS.		
	Model No.	Part No.	Model No.	Part No.	Throat Depth	Length A	Shipping Weight
BASE ASSEMBLIES LESS PUNCH & DIE	8AH-3-LPD	3700-LPD	8SAH-3-LPD	3705-LPD	8"	11 5/8"	73 lbs.
	12AH-3-LPD	3701-LPD	12SAH-3-LPD	3706-LPD	12"	15 5/8"	83 lbs.
COMPLETE UNITS (Includes Punch & Die)	8AH-3	3700	8SAH-3	3705	8"	11 5/8"	75 lbs.
	12AH-3	3701	12SAH-3	3706	12"	15 5/8"	85 lbs.

*To order a shaped unit with round punch & die, add the suffix "- RPD"

KITS AND SHIMS

All AH-3 units furnished with Shaped Driver

Key kit:	9307
Hardware kit:	9359
Punch shim:	3709 1/16" thk./2 max.
Die shim:	N.A.
Guide bushing installation kit:	2065

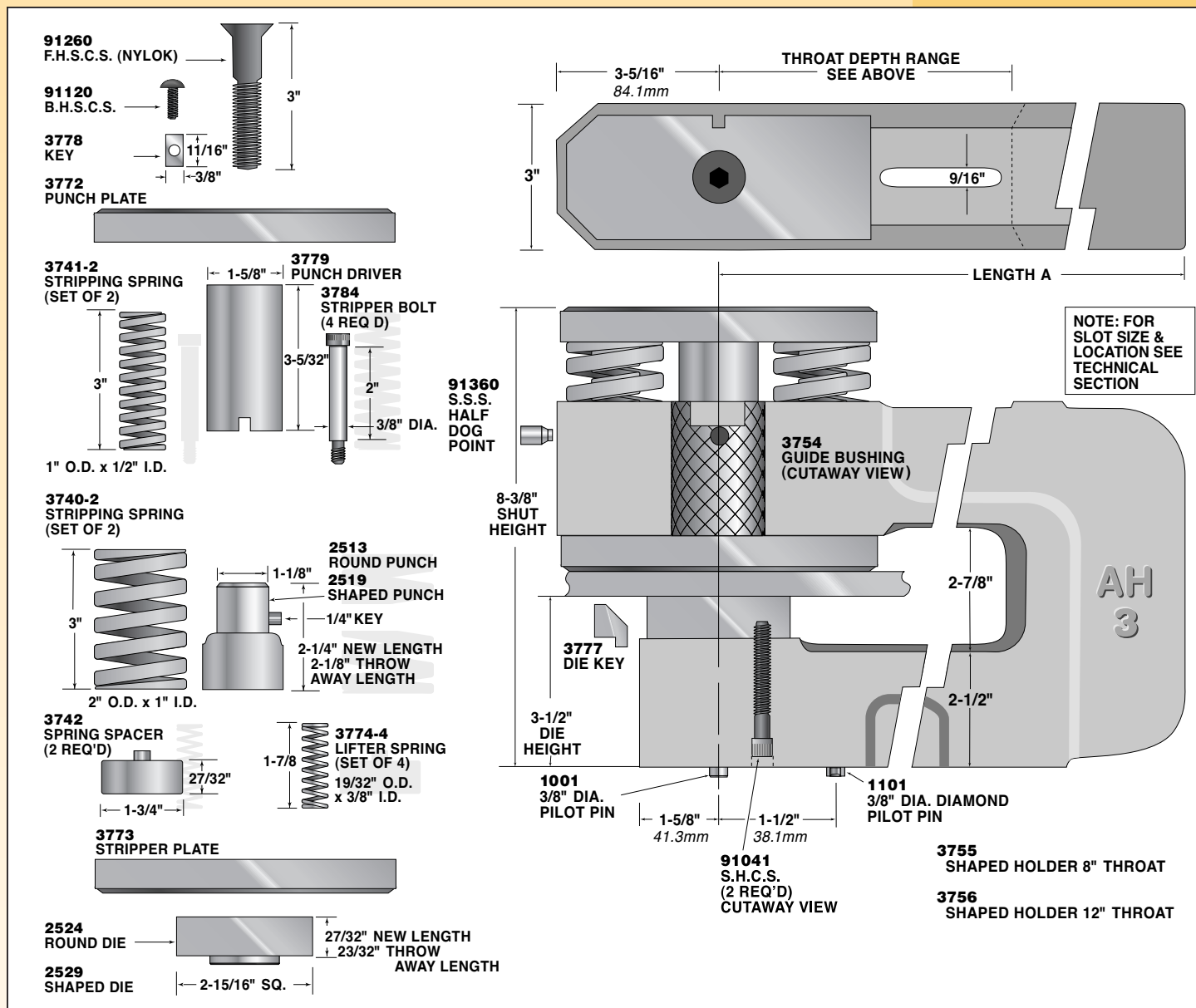

A SERIES

SPEED WITHIN REACH

UNIPUNCH

AH-3 1/2"

88.9mm width

SPECIFICATIONS & OPERATING INSTRUCTIONS

OPERATING SHUT HEIGHT:	8-3/8" (212.7mm)
MIN. SHUT HEIGHT:	8-3/16" (208.0mm)
UNIT OPEN HEIGHT:	9-3/8" (238.1mm)
DIE HEIGHT:	3-1/2" (88.9mm)
MATERIAL FEED CLEARANCE:	5/8" (15.9mm)
MIN. DIE CLEARANCE:	.018" (.46mm)
MAX. MAT. THK. (M.S.):	1/2" (12.7mm)

MAX. PUNCH DIAMETER:	1.250" (31.75mm) in 1/2" (12.7mm) M.S. 2.000" (50.8mm) in 1/4" (6.4mm) M.S.
MIN. PUNCH DIAMETER:	.5000" (12.7mm)
MAX. SQUARE:	1.414" (35.9mm)
MIN. SHAPE DIMENSION:	.1250" (3.18mm)
MAX. MAT. THK. (S.S.):	5/32" (4.0mm)

KITS AND SHIMS

Shaped hole conversion kit:	7131
Key kit:	9308
Hardware kit:	9360
Punch shim:	1109-12 pk. 1109-48 pk. 1/16" thk./3 max.
Die shim:	1095 1/16" thk./2 max.
Guide bushing installation kit:	2065

	ROUND UNITS		*SHAPED UNITS		COMMON DIMS.		
	Model No.	Part No.	Model No.	Part No.	Throat Depth	Length A	Shipping Weight
BASE ASSEMBLIES LESS PUNCH & DIE	8AH-3 1/2-LPD	2500-LPD	8SAH-3 1/2-LPD	2505-LPD	8"	12"	40 lbs.
	12AH-3 1/2-LPD	2501-LPD	12SAH-3 1/2-LPD	2506-LPD	12"	16"	47 lbs.
COMPLETE UNITS (Includes Punch & Die)	8AH-3 1/2	2500	8SAH-3 1/2	2505	8"	12"	43 lbs.
	12AH-3 1/2	2501	12SAH-3 1/2	2506	12"	16"	50 lbs.

*To order a shaped unit with round punch & die, add the suffix "- RPD"

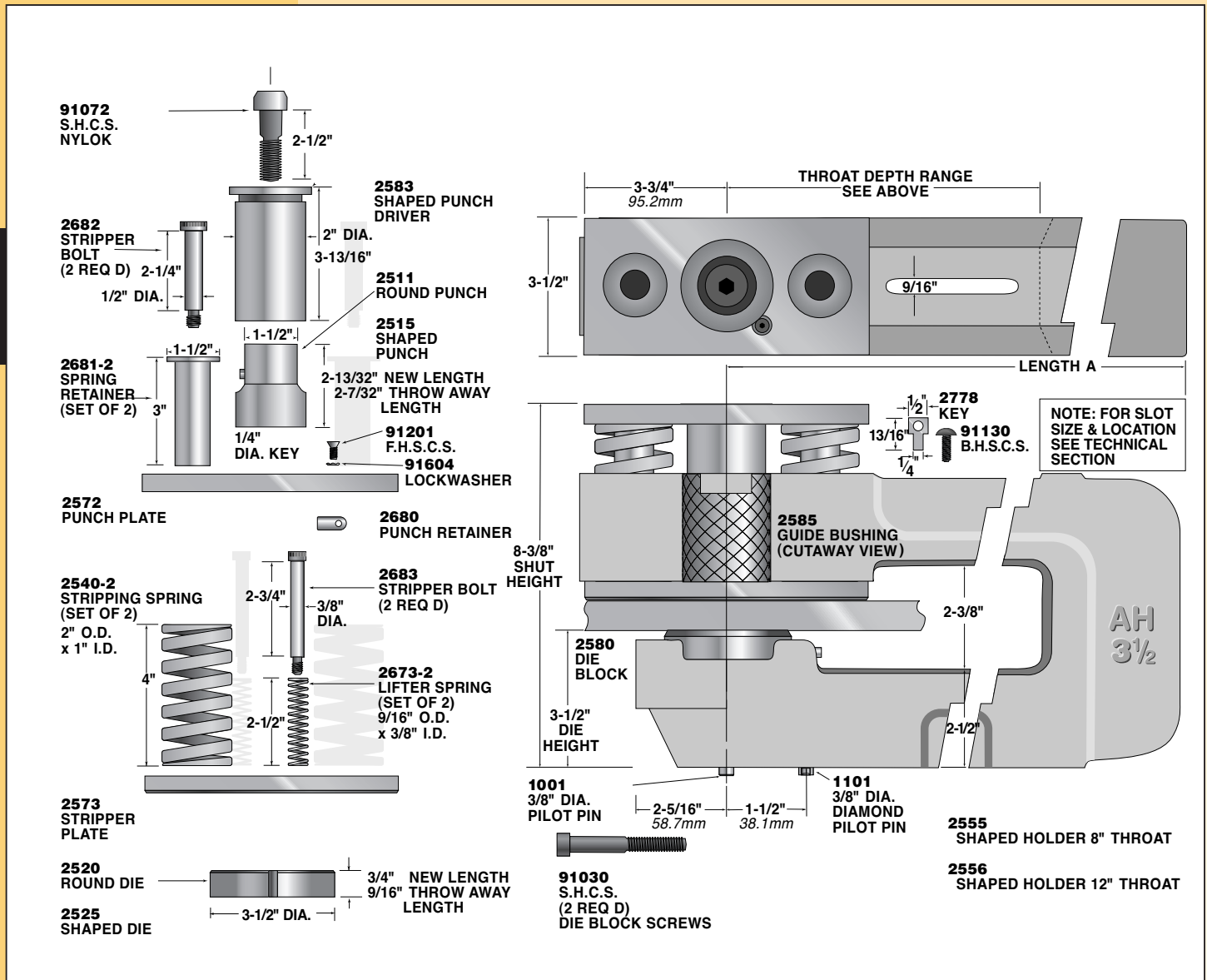

SPEED WITHIN REACH

UNIPUNCH

SPECIFICATIONS & OPERATING INSTRUCTIONS

OPERATING SHUT HEIGHT:	8-3/8" (212.7mm)
MIN. SHUT HEIGHT:	8-3/16" (208.0mm)
UNIT OPEN HEIGHT:	9-5/8" (244.5mm)
DIE HEIGHT:	3-1/2" (88.9mm)
MATERIAL FEED CLEARANCE:	5/8" (15.9mm)
MIN. DIE CLEARANCE:	.018" (.46mm)
MAX. MAT. THK. (M.S.):	1/2" (12.7mm)

MAX. PUNCH DIAMETER:	1.500" (38.10mm) in 1/2" (12.7mm) M.S. 2.000" (50.80mm) in 3/8" (9.5mm) M.S. 3.000" (76.20mm) in 1/4" (6.4mm) M.S.
MIN. PUNCH DIAMETER:	1.000" (25.40mm)
MAX. SQUARE:	2.121" (53.87mm)
MIN. SHAPE DIMENSION:	.1875" (4.76mm)
MAX. MAT. THK. (S.S.):	5/32" (4.0mm)

AH-6[™]

139.7mm width

	ROUND UNITS		*SHAPED UNITS		COMMON DIMS.		
	Model No.	Part No.	Model No.	Part No.	Throat Depth	Length A	Shipping Weight
BASE ASSEMBLIES LESS PUNCH & DIE	8AH-6-LPD	2700-LPD	8SAH-6-LPD	2706-LPD	8"	12 1/2"	119 lbs.
	12AH-6-LPD	2701-LPD	12SAH-6-LPD	2707-LPD	12"	16 1/2"	139 lbs.
COMPLETE UNITS (Includes Punch & Die)	8AH-6	2700	8SAH-6	2706	8"	12 1/2"	124 lbs.
	12AH-6	2701	12SAH-6	2707	12"	16 1/2"	144 lbs.

*To order a shaped unit with round punch & die, add the suffix "- RPD"

KITS AND SHIMS

All AH-6 units furnished with Shaped Driver

Key kit: 9309

Hardware kit: 9361

Punch shim:

For rounds 1109-12 pk.
2-1/4" dia. 1109-48 pk.
& less: 1/16" thk./3 max.

For rounds > 2-1/4" dia. 1197-12 pk.
& all shapes: 1/16" thk./3 max.

Die shim: 1128

1/16" thk./3 max.

Guide bushing installation kit: 2065

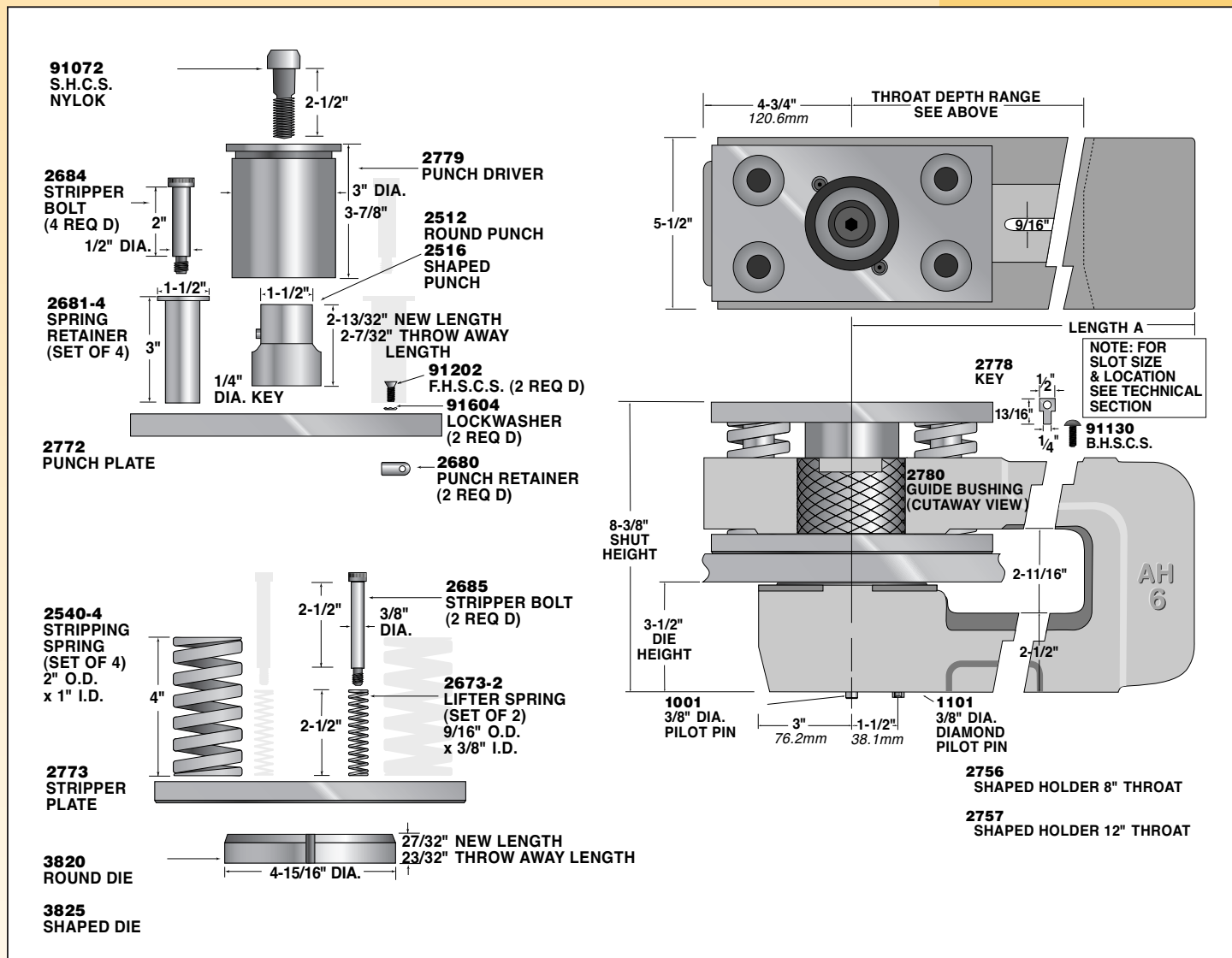

A SERIES

OA-6[®]

139.7mm width

SPECIFICATIONS & OPERATING INSTRUCTIONS

OPERATING SHUT HEIGHT:	8-3/8" (212.7mm)
MIN. SHUT HEIGHT:	8-3/16" (208.0mm)
UNIT OPEN HEIGHT:	9-5/8" (244.5mm)
DIE HEIGHT:	3-1/2" (88.9mm)
MATERIAL FEED CLEARANCE:	5/8" (15.9mm)
MAX. MAT. THK. (M.S.):	3/8" (9.5mm)
MIN. DIE CLEARANCE:	.018" (.46mm)

MAX. PUNCH DIAMETER:	2.000" (50.80mm) in 3/8" (9.5mm) M.S. 3.000" (76.20mm) in 1/4" (6.4mm) M.S. 4.000" (101.60mm) in 3/16" (4.8mm) M.S.
MIN. PUNCH DIAMETER:	1.500" (38.1mm)
MAX. SQUARE:	2.828" (71.83mm)
MIN. SHAPE DIMENSION:	.250" (6.35mm)
MAX. MAT. THK. (S.S.):	5/32" (4.0mm)

KITS AND SHIMS

All OA-6 units furnished with Shaped Driver

Key kit: 9314

Hardware kit: 9361

Punch shim:

For rounds 1109-12 pk.
2-1/4" dia. 1109-48 pk.
& less: 1/16" thk./3 max.

For rounds > 2-1/4" dia. 1197-12 pk
& all shapes: 1/16" thk./3 max.

Die shim: N.A.

	ROUND UNITS		*SHAPED UNITS		COMMON DIMS.		
	Model No.	Part No.	Model No.	Part No.	Throat Depth	Length A	Shipping Weight
BASE ASSEMBLIES LESS PUNCH & DIE	8OA-6-LPD	2800-LPD	8SOA-6-LPD	2805-LPD	8"	12 1/2"	119 lbs.
	12OA-6-LPD	2801-LPD	12SOA-6-LPD	2806-LPD	12"	16 1/2"	139 lbs.
COMPLETE UNITS (Includes Punch & Die)	8OA-6	2800	8SOA-6	2805	8"	12 1/2"	124 lbs.
	12OA-6	2801	12SOA-6	2806	12"	16 1/2"	144 lbs.

*To order a shaped unit with round punch & die, add the suffix "- RPD"

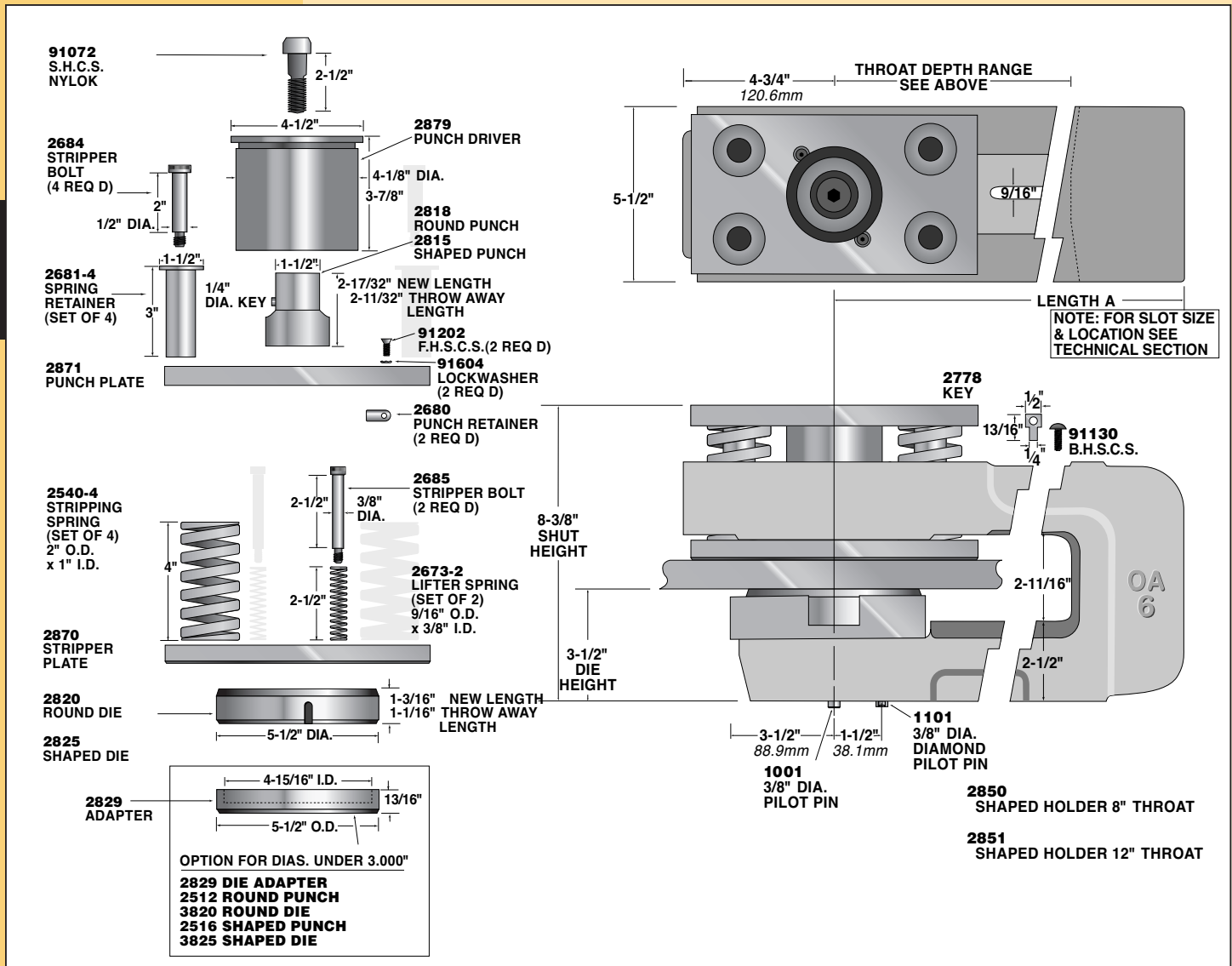

A SERIES

SPEED WITHIN REACH

UNIPUNCH

SPECIFICATIONS & OPERATING INSTRUCTIONS

OPERATING SHUT HEIGHT:	8-3/8" (212.7mm)	MIN. DIE CLEARANCE:	.018" (.46mm)
MIN. SHUT HEIGHT:	8-3/16" (208.0mm)	MAX. PUNCH DIAMETER:	1.1250" (28.57mm)
UNIT OPEN HEIGHT:	9-5/16" (236.5mm)	MIN. PUNCH DIAMETER:	.2500" (6.35mm)
DIE HEIGHT:	3-1/2" (88.9mm)	MAX. SQUARE:	.795" (20.19mm)
MATERIAL FEED CLEARANCE:	7/8" (22.2mm)	MIN. SHAPE DIMENSION:	.1875" (4.76mm)
MAX. MATERIAL THICKNESS (MILD STEEL):	3/4" (19.0mm)	MAX. MATERIAL THICKNESS (STAINLESS STEEL):	5/32" (4.0mm)

AD-4"

101.6mm width

	ROUND UNITS		*SHAPED UNITS		COMMON DIMS.		
	Model No.	Part No.	Model No.	Part No.	Throat Depth	Length A	Shipping Weight
BASE ASSEMBLIES LESS PUNCH & DIE	8AD-4-LPD	2630-LPD	8SAD-4-LPD	2635-LPD	8"	11 3/4"	72 lbs.
	12AD-4-LPD	2631-LPD	12SAD-4-LPD	2636-LPD	12"	15 3/4"	82 lbs.
COMPLETE UNITS (Includes Punch & Die)	8AD-4	2630	8SAD-4	2635	8"	11 3/4"	75 lbs.
	12AD-4	2631	12SAD-4	2636	12"	15 3/4"	85 lbs.

*To order a shaped unit with round punch & die, add the suffix "- RPD"

KITS AND SHIMS

Shaped hole conversion kit:	N.A.
Key kit:	9310
Hardware kit:	9362
Punch shim:	N.A.
Die shim:	N.A.
Guide bushing installation kit:	2065

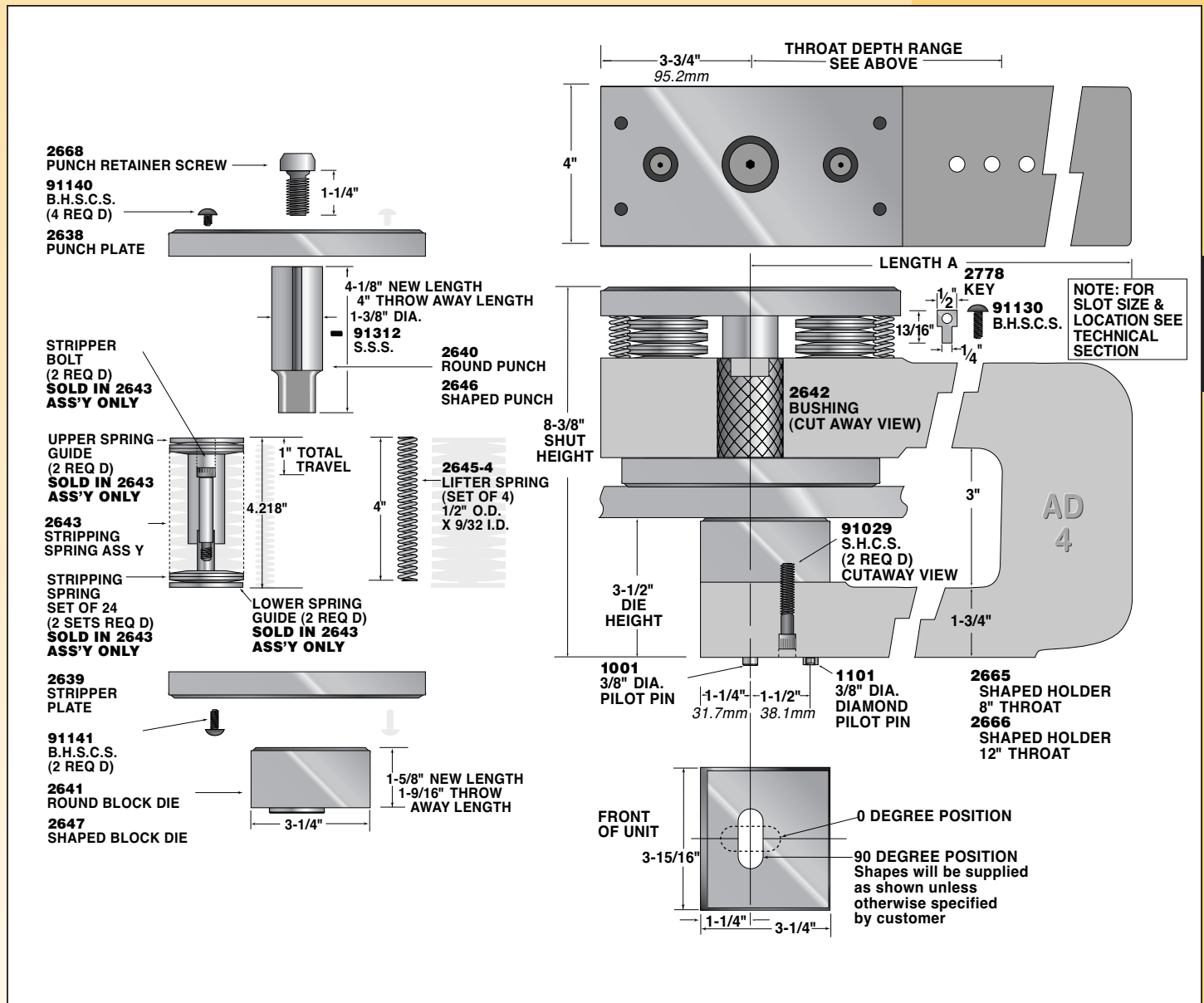

A SERIES

AJD-2"

For Stainless Steel Punching

ADJ-2" (50.8mm width)

SPECIFICATIONS & OPERATING INSTRUCTIONS

OPERATING SHUT HEIGHT:	8-3/8" (212.7mm)	MAX. PUNCH DIAMETER:	.5000" (12.70mm)
MIN. SHUT HEIGHT:	8-3/16" (208.0mm)	MIN. PUNCH DIAMETER:	.2812" (7.14mm)
UNIT OPEN HEIGHT:	9-1/8" (231.8mm)	MAX. SQUARE:	.353" (8.96mm)
DIE HEIGHT:	3-1/2" (88.9mm)	MIN. SHAPE DIMENSION:	.1250" (3.18mm)
MATERIAL FEED CLEARANCE:	7/16" (11.1mm)	MAX. MAT. THK. (S.S.):	1/4" (6.4mm)
MIN. DIE CLEARANCE:	.006" (.1 mm)		14 TONS MAX.

Note: 25% of material thickness is suggested die clearance

KITS AND SHIMS

Shaped hole conversion kit:	7124
Key kit:	9322
Hardware kit:	9377
Punch shim:	N.A.
Pedestal/Adapter Die shim:	1119-12 pk. 1119-48 pk. 1/16" thk./3 max.
Upper Arm Kits:	9737 Round 9738 Shaped

COMPLETE ROUND UNITS	
Model No.	Part No.
4AJD-2	17051
8AJD-2	17052
12AJD-2	17053

COMPLETE SHAPED UNITS	
Model No.	Part No.
4SAJD-2	17056
8SAJD-2	17057
12SAJD-2	17058

COMMON DIMENSIONS		
Throat Depth	Length A	Shipping Weight
4"	7"	19 lbs.
8"	11"	23 lbs.
12"	15"	28 lbs.

To order a unit less punch and die, add the suffix "- LPD".

To order a shaped unit with round punch & die, add the suffix "- RPD".

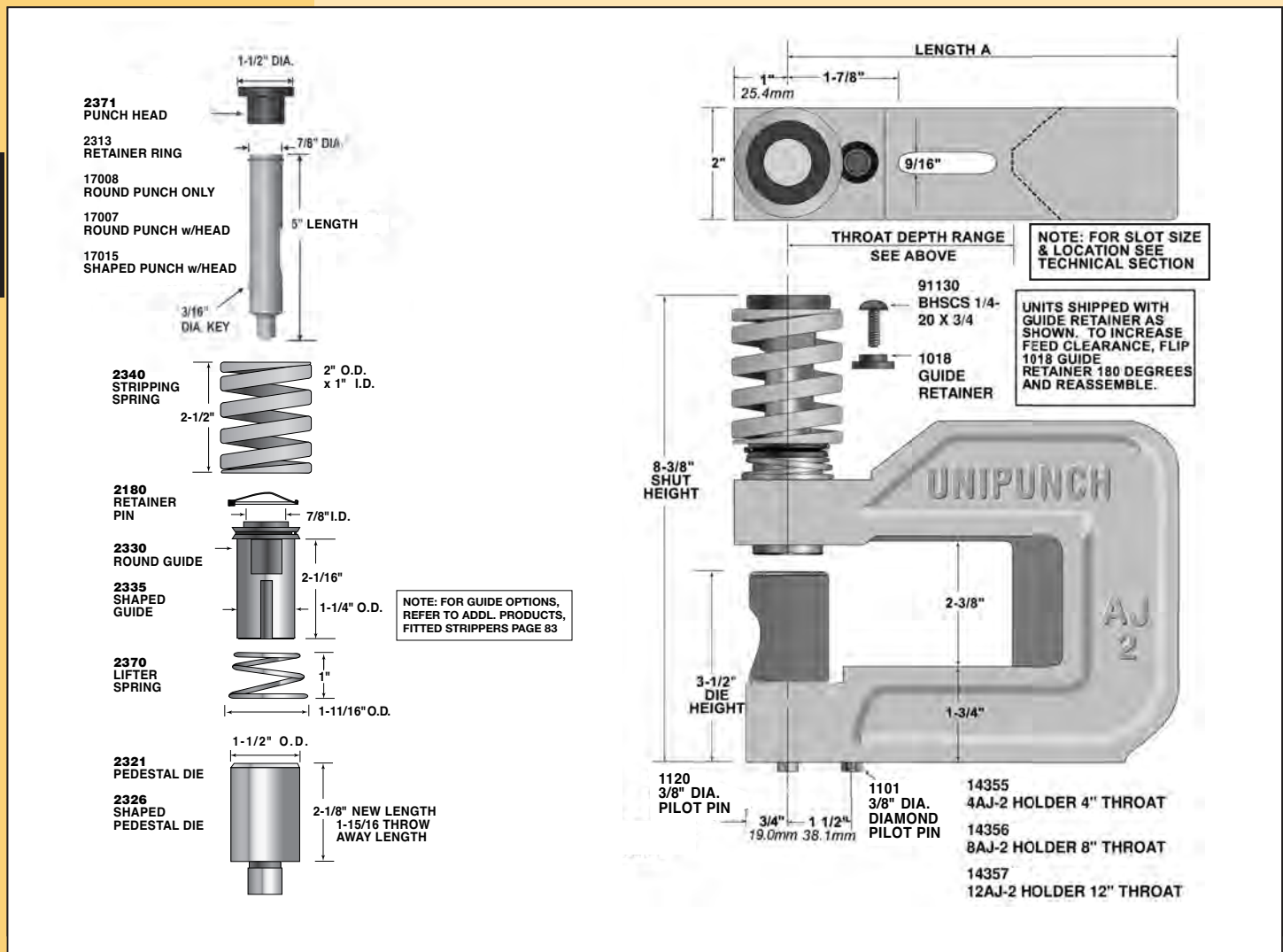

SPEED WITHIN REACH

UNIPUNCH

AHD-2½" (50.8mm width)

SPECIFICATIONS & OPERATING INSTRUCTIONS

OPERATING SHUT HEIGHT:	8-3/8" (212.7mm)	MIN. DIE CLEARANCE:	.018" (.46mm)
MIN. SHUT HEIGHT:	8-3/16" (208.0mm)	MAX. PUNCH DIAMETER:	.8750" (22.22mm)
UNIT OPEN HEIGHT:	9-3/8" (238.1mm)	MIN. PUNCH DIAMETER:	.2812" (7.14mm)
DIE HEIGHT:	3-1/2" (88.9mm)	MAX. SQUARE:	.618" (15.70mm)
MATERIAL FEED CLEARANCE:	5/8" (15.9mm)	MIN. SHAPE DIMENSION:	.1250" (3.18mm)
		MAX. MATERIAL THICKNESS (STAINLESS STEEL):	1/4" (6.4mm) 24 TONS MAX.

AHD-2½"

For Stainless Steel Punching

Note: 25% of material thickness is suggested die clearance

COMPLETE ROUND UNITS		COMPLETE SHAPED UNITS		COMMON DIMENSIONS		
Model No.	Part No.	Model No.	Part No.	Throat Depth	Length A	Shipping Weight
8AHD-2 1/2	17151	8SAHD-2 1/2	17155	8"	11 5/8"	43 lbs.
12AHD-2 1/2	17152	12SAHD-2 1/2	17156	12"	15 5/8"	50 lbs.

To order a unit less punch and die, add the suffix "- LPD".

To order a shaped unit with round punch & die, add the suffix "- RPD".

KITS AND SHIMS

Shaped hole conversion kit:	7130
Key kit :	9306
Hardware kit:	9358
Punch shim:	1114-12 pk. 1114-48 pk. 1/16" thk./3 max.
Die shim:	1094-12 pk. 1094-48 pk. 1/16" thk./2 max.
Guide bushing installation kit:	2065

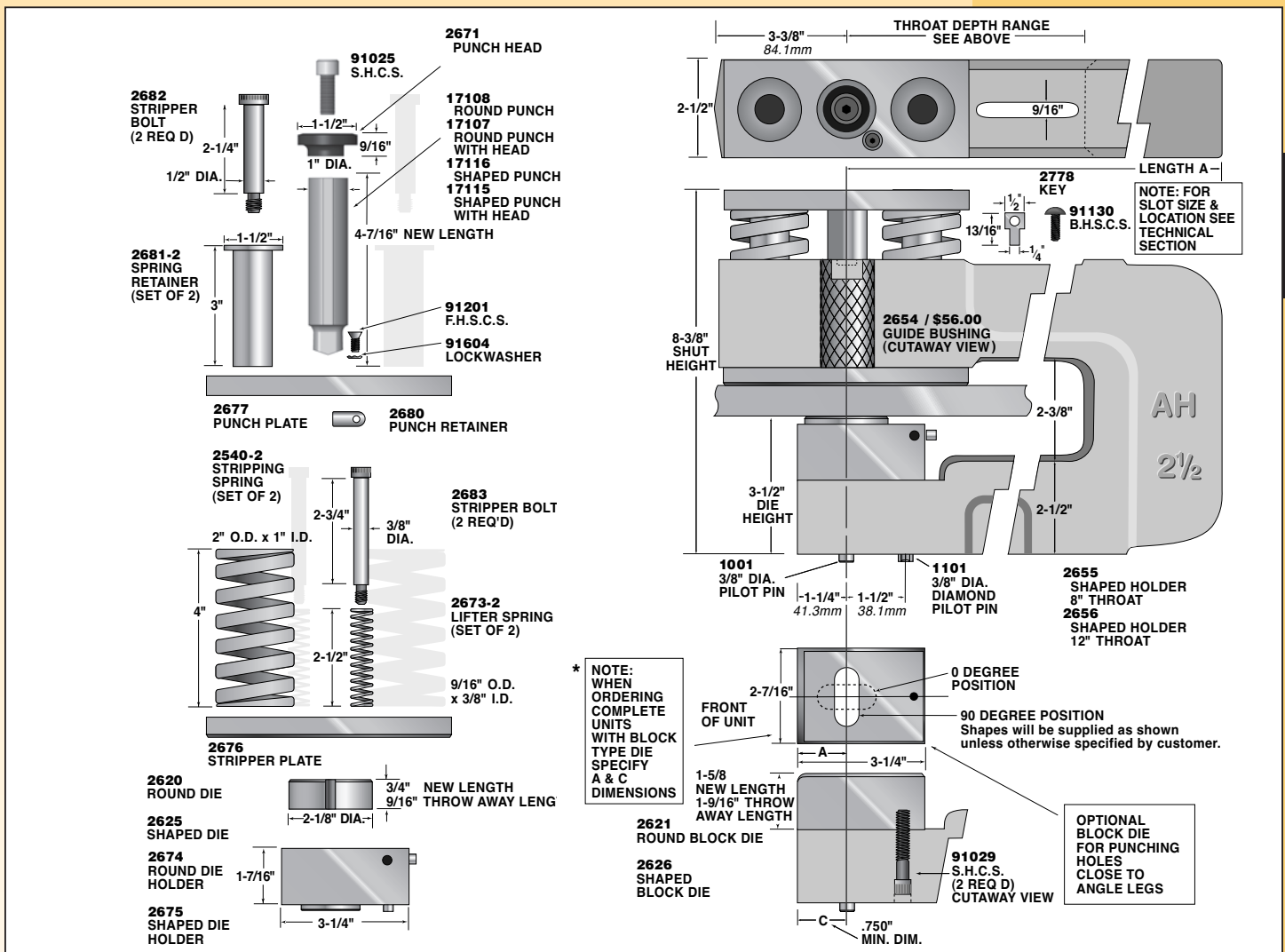

A SERIES

AHD-3"

For Stainless Steel Punching

AHD-3" (76.2mm width)

SPECIFICATIONS & OPERATING INSTRUCTIONS

OPERATING SHUT HEIGHT:	8-3/8" (212.7mm)	MAX. PUNCH DIAMETER:	1.1250" (28.57mm)
MIN. SHUT HEIGHT:	8-3/16" (208.0mm)	MIN. PUNCH DIAMETER:	.3750" (9.53mm)
UNIT OPEN HEIGHT:	9-5/8" (244.5mm)	MAX. SQUARE:	.795" (20.19mm)
DIE HEIGHT:	3-1/2" (88.9mm)	MIN. SHAPE DIMENSION:	.1250" (3.18mm)
MATERIAL FEED CLEARANCE:	5/8" (15.9mm)	MAX. MAT. THK. (S.S.):	1/4" (6.4mm)
MIN. DIE CLEARANCE:	.018" (.46mm)		31 TONS MAX.

KITS AND SHIMS

All AH-3 units furnished with Shaped Driver

Key kit:	9307
Hardware kit:	9359
Punch shim:	3709
	1/16" thk./2 max.
Die shim:	N.A.
Guide bushing installation kit:	2065

Note: 25% of material thickness is suggested die clearance

COMPLETE ROUND UNITS		COMPLETE SHAPED UNITS		COMMON DIMENSIONS		
Model No.	Part No.	Model No.	Part No.	Throat Depth	Length A	Shipping Weight
8AHD-3	17251	8SAHD-3	17255	8"	11-5/8"	43 lbs.
12AHD-3	17252	12SAHD-3	17256	12"	15-5/8"	50 lbs.

To order a unit less punch and die, add the suffix "- LPD".

To order a shaped unit with round punch & die, add the suffix "- RPD".

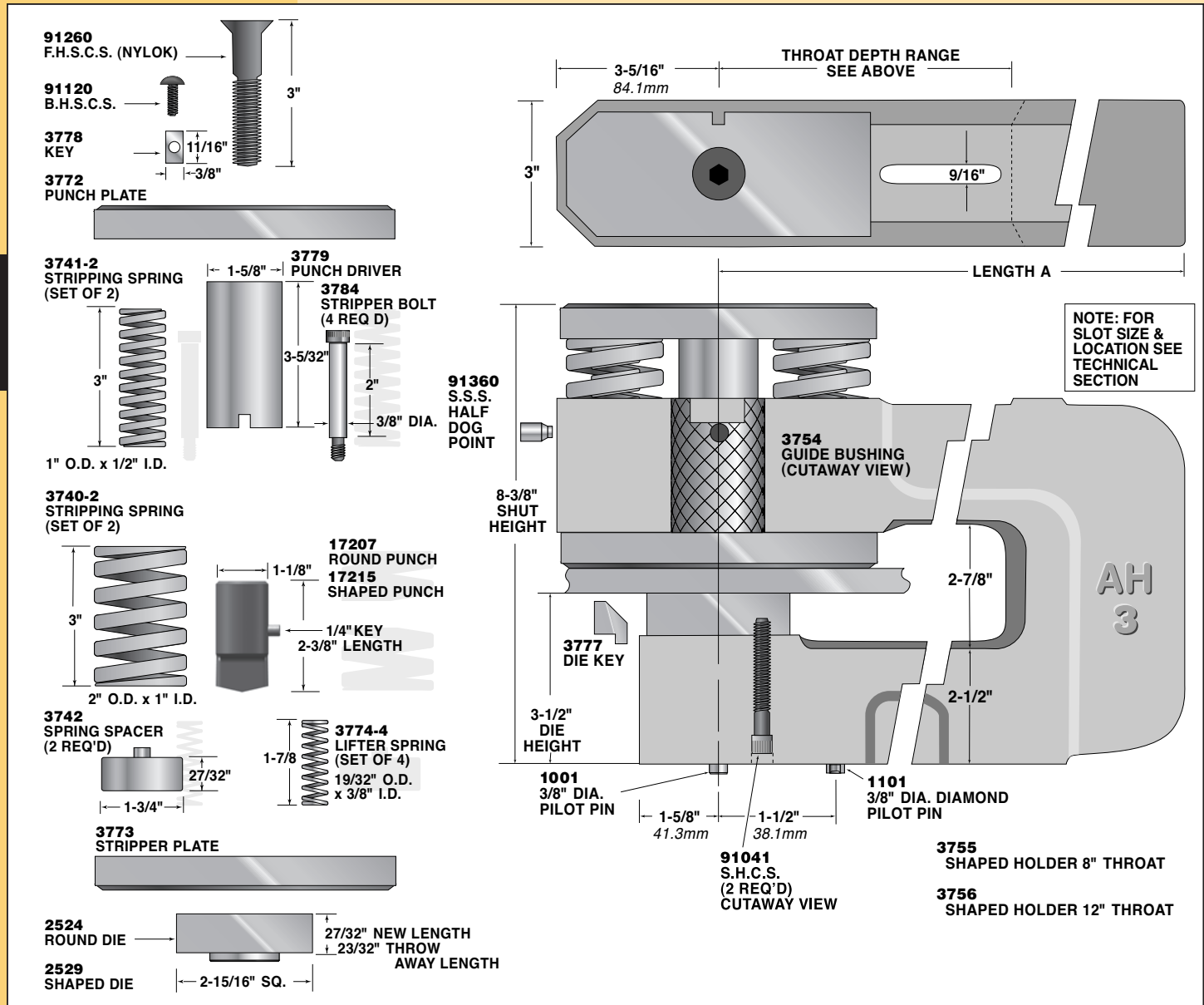

A SERIES

AHD-3 1/2" (88.9mm width)

SPECIFICATIONS & OPERATING INSTRUCTIONS

OPERATING SHUT HEIGHT:	8-3/8" (212.7mm)	MAX. PUNCH DIAMETER:	1.5000" (38.10mm)
MIN. SHUT HEIGHT:	8-3/16" (208.0mm)	MIN. PUNCH DIAMETER:	.5000" (12.70mm)
UNIT OPEN HEIGHT:	9-3/8" (238.1mm)	MAX. SQUARE:	1.060" (26.92mm)
DIE HEIGHT:	3-1/2" (88.9mm)	MIN. SHAPE DIMENSION:	.1250" (3.18mm)
MATERIAL FEED CLEARANCE:	5/8" (15.9mm)	MAX. MAT. THK. (S.S.):	1/4" (6.4mm)
MIN. DIE CLEARANCE:	.018" (.46mm)		42 TONS MAX.

AHD-3 1/2"

For Stainless Steel Punching

Note: 25% of material thickness is suggested die clearance

COMPLETE ROUND UNITS		COMPLETE SHAPED UNITS		COMMON DIMENSIONS		
Model No.	Part No.	Model No.	Part No.	Throat Depth	Length A	Shipping Weight
8AHD-3 1/2	17354	8SAHD-3 1/2	17358	8"	12"	75 lbs.
12AHD-3 1/2	17355	12SAHD-3 1/2	17359	12"	16"	85 lbs.

To order a unit less punch and die, add the suffix "- LPD".

To order a shaped unit with round punch & die, add the suffix "- RPD".

KITS AND SHIMS

Shaped hole conversion kit:	7131
Key kit:	9308
Hardware kit:	9360
Punch shim:	1109-12 pk. 1109-48 pk. 1/16" thk./3 max.
Die shim:	1095. 1/16" thk./2 max.
Guide bushing installation kit:	2065

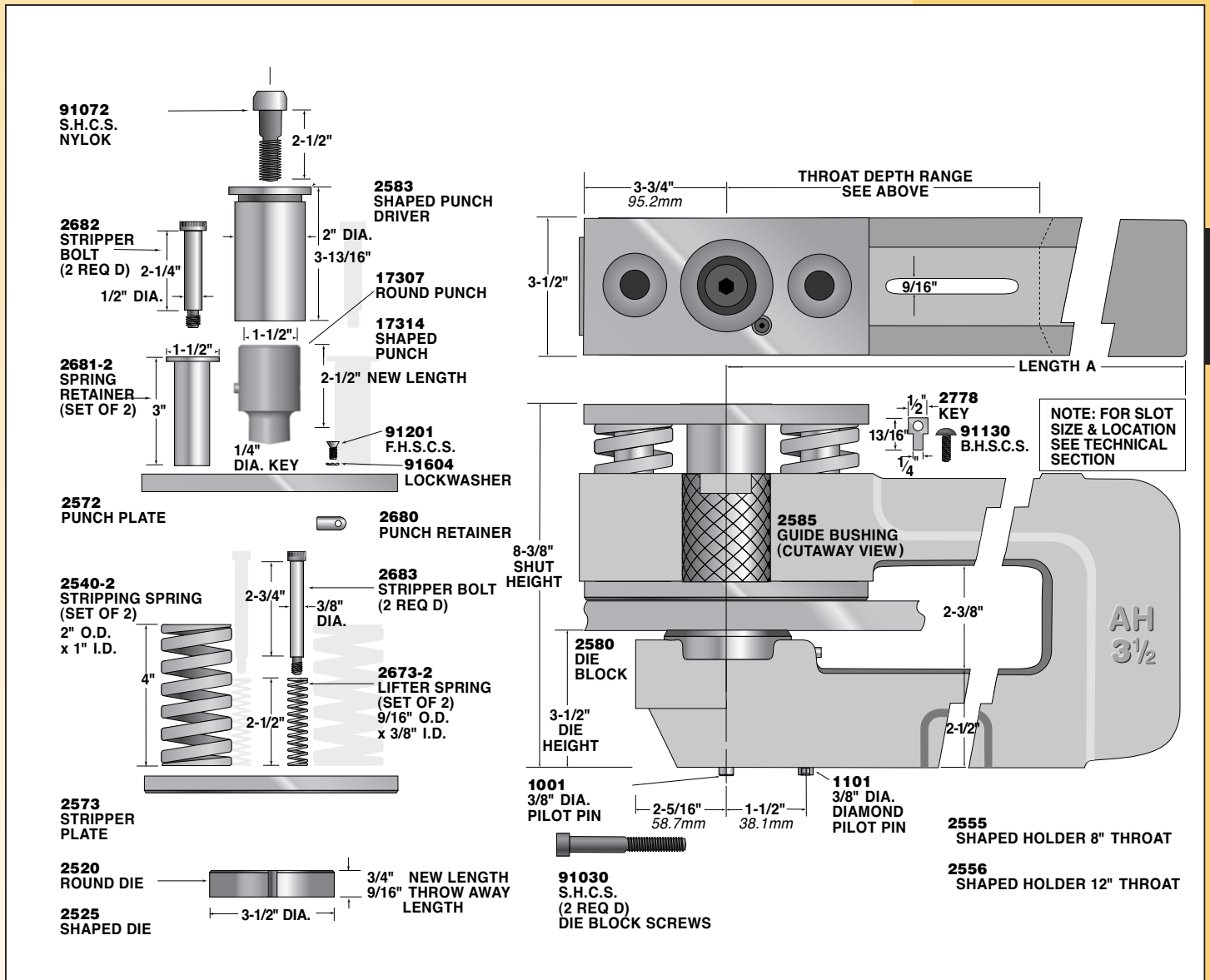

A SERIES

A SERIES Corner NOTCH

SPECIFICATIONS & OPERATING INSTRUCTIONS

OPERATING SHUT HEIGHT:	8-3/8" (212.7mm)
MIN. SHUT HEIGHT:	8-3/16" (208.0mm)
UNIT OPEN HEIGHT:	9" (228.6mm)
DIE HEIGHT:	3-1/2" (88.9mm)
MAX. MATERIAL THICKNESS (MILD STEEL):	1/4" (6.4mm)

MATERIAL FEED CLEARANCE:	11/32" (8.7mm)
MIN. DIE CLEARANCE:	Die Clearance is preset at factory for notching up to 1/4" (6.4mm) mild steel.
MAX. MATERIAL THICKNESS (STAINLESS STEEL):	3/32" (2.4mm)

Note: All Corner Notching Units have replaceable punch and die steels.

A Series – Corner Notch Units: 5" x 5" and 3" x 3"

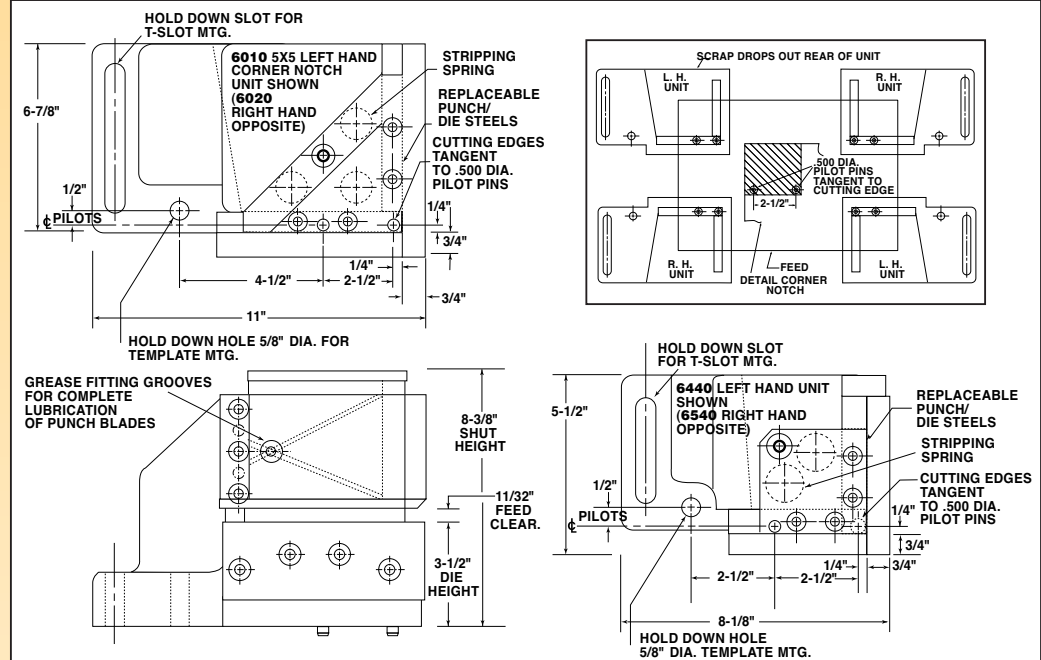

NOTCHING UNITS

Type	Part No.	Max. Notch Dia.	Ship. Wt.
L.H.	6010	5" x 5"	102 lbs.
	6440	3" x 3"	58 lbs.
R.H.	6020	5" x 5"	102 lbs.
	6450	3" x 3"	58 lbs.

Item No.	Parts Description	6010 Part No.	6020 Part No.	6440 Part No.	6450 Part No.
1	Punch Blade (long)	6091	6091	6404	6404
2	Punch Blade (short)	6090	6090	6403	6403
3	Punch Plate	6074	6074	6439	6439
4	Die Steel (long)	6080	6081	7046	7047
5	Die Steel (short)	6082	6083	7044	7045
6	Set of Die Screws	6002 (set of 8)	6002 (set of 8)	7052 (set of 6)	7052 (set of 6)
7	Spring (2 or 3 req'd)	6040	6040	6040	6040
8	Spring Cage	6043	6043	6043	6043
9	Retainer	2476	2476	2476	2476
10	Stripper Bolt	91401	91401	91401	91401
11	Round Pilot Pin	1006	1006	1006	1006
12	Diamond Pilot Pin	1116	1116	1116	1116
13	Punch Plate Screw	91080	91080	91080	91080

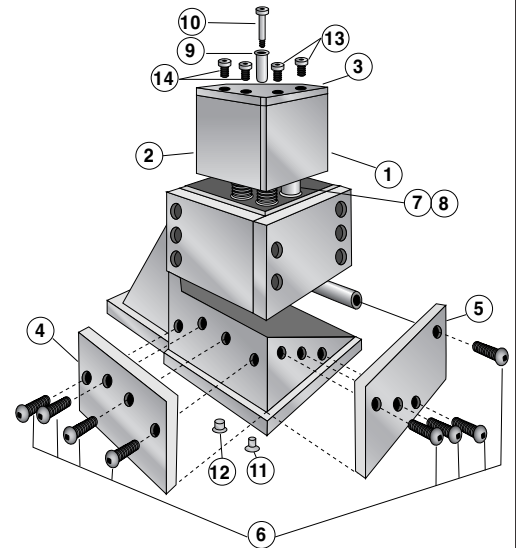

6060 and 6050 Gauging Methods



Gauging plate with built-in scales and adjustable stops
Part No. 6060



Adjustable side gauges for each cutting side
Set of 2
Part No. 6050

SPECIFICATIONS & OPERATING INSTRUCTIONS

OPERATING SHUT HEIGHT:	8-3/8" (212.7mm)
MIN. SHUT HEIGHT:	8-3/16" (208.0mm)
UNIT OPEN HEIGHT:	9" (228mm)
DIE HEIGHT:	3-1/2" (88.9mm)

MIN. DIE CLEARANCE:	Die Clearance is preset at factory
MAX. MATERIAL THICKNESS (MILD STEEL):	1/4" (6.4mm)
MAX. MATERIAL THICKNESS (STAINLESS STEEL):	3/32" (2.4mm)

6300

Flat Stock Cutoff Units

6300 - FLAT STOCK CUTOFF UNITS

Part No.	Max. Cutoff Width A	B	C	Max. Tonnage	Shipping Weight
6300-200	2"	10½"	9¼"	14	85 lbs.
6300-400	4"	12½"	11¼"	28	101 lbs.
6300-600	6"	14½"	13¼"	42	116 lbs.
6300-800	8"	16½"	15¼"	56	133.5 lbs.

Note: For sizes not shown, contact UniPunch Sales Department for application information and pricing.

Note: Punch & die steels in Flat Stock Cutoff Units are not interchangeable. Units must be returned to factory for replacement. Spare punch & die steels can be supplied with new units.

UniPunch "A" Series 6300 Flat Stock Cutoff Units are a self-contained two post die shearing unit available in widths up to 8" (203.2mm). These units can be mounted in a press or press brake in conjunction with other "A" Series tooling or can be used for stand-alone cut to length applications in mild steel up to 1/4" (6.4mm) thickness. Other widths can be manufactured to your requirements.

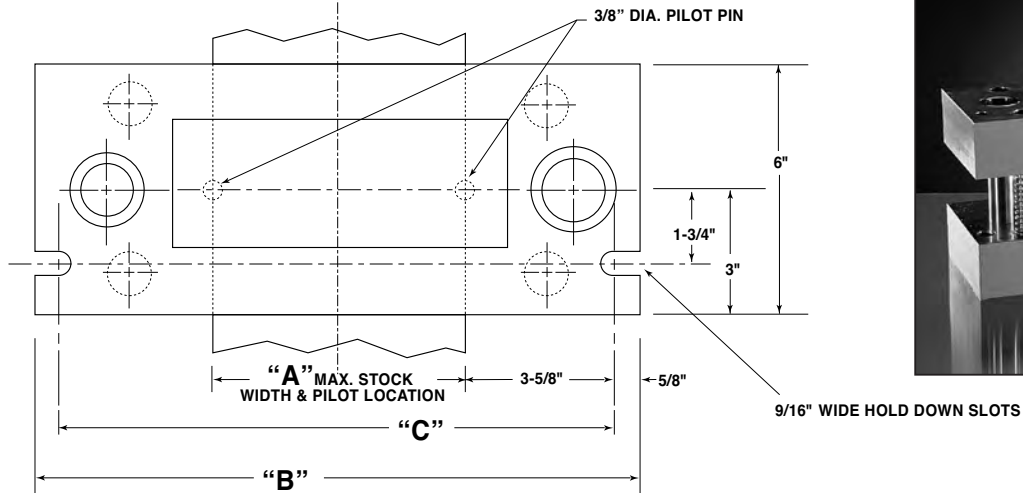

A SERIES

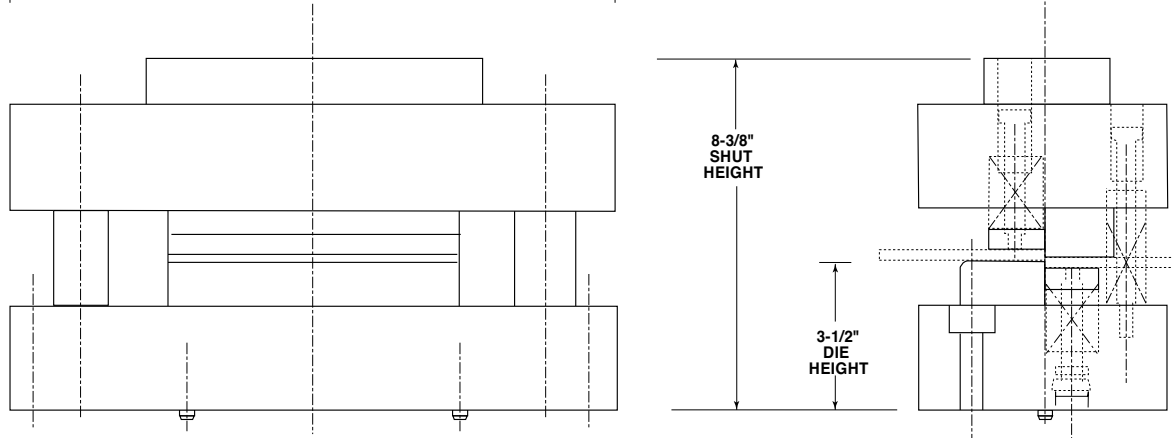

B Series Lineup

B, BX, B-Notching, B-Shearing and B-Corner Radius

- 5-1/2" shut height & 2-19/32" die height
- Material Thickness: Up to 10 gauge (.1345")
- Designed for press equipment with limited die space

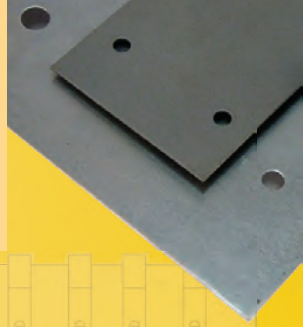
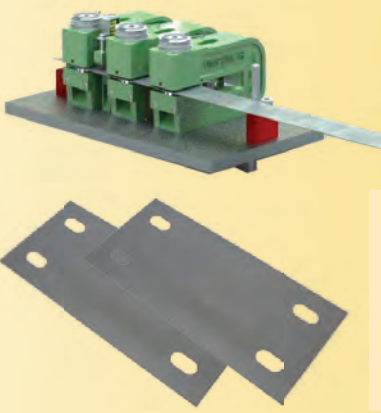

B Units (Pages 55 - 61)

"B" and "BX" units are ideal for lighter duty punching applications and for press environments with limited opening. Available "B" units holder widths are: 3/4", 1-1/4", 1-3/4", 2-1/4", 3" and 5". Holder width is important because it defines the minimum hole to hole distance. The "B" units are widely used in industry to punch mild steel in thickness up to 10 gauge. Depending on your material thickness, punch diameters are available up to 3.500" (88.90mm). (For thicker punching applications, see the UniPunch "A" Series.)



Shown above are UniPunch "B" units mounted in a press brake with a limited opening between the press ram and bed. Keyed mounting templates are available for positioning "B" units and gauges to produce accurate parts with each stroke of the press.

B Series Lineup

B, BX, B-Notching, B-Shearing and B-Corner Radius

- 5-1/2" shut height & 2-19/32" die height
- Material Thickness: Up to 10 gauge (.1345")
- Designed for press equipment with limited die space

B Series Notching Units (Pages 62 - 65)

These units are designed to operate as stand-alone tools or can be used in conjunction with the UniPunch "B" Series Lineup of hole punching units to punch and notch parts within the same press setup.



Corner Notching Units (Pages 62 - 63)

UniPunch "B" Series Corner Notch Units are self-contained dies available in 90 degree left hand and right hand units. Three models are offered for corner notch sizes of up to 3" x 3", 5" x 5" or 8" x 8". Die clearance is pre-set at the factory for notching up to 10 gauge mild steel.

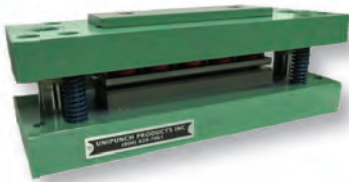

B-Series Flat Stock Cutoff Unit (Page 66)

UniPunch "B" Series 5300 Flat Stock Cutoff Units are self-contained two post die shearing units available in widths up to 8". These units can be mounted in a press or press brake adjacent to existing C-frame tooling or stand-alone cut-to-length applications in up to 10 gauge mild steel. Other widths can be manufactured to your requirements.



B Series Corner Radius Unit (Page 67)

The UniPunch "B" Series 4000 Radius Unit uses a modified B-3 holder. The unit is delivered complete with holder, built-in squaring guides and a punch and die pair that permits four radii options. Typically this unit is used as a stand-alone unit for putting corner radii on flat material up to 10 gauge mild steel.

SPECIFICATIONS & OPERATING INSTRUCTIONS

OPERATING SHUT HEIGHT:	5-1/2" (139.7mm)
MIN. SHUT HEIGHT:	5-3/8" (136.5mm)
UNIT OPEN HEIGHT:	5-7/8" (149.2mm)
DIE HEIGHT:	2-19/32" (65.9mm)
MATERIAL FEED CLEARANCE:	7/32" (5.5mm)
MAX. MATERIAL THICKNESS (MILD STEEL):	10 GA./ .134" (3.4mm)

MIN. DIE CLEARANCE:	.006" (.15mm)
MAX. PUNCH DIAMETER:	.3125" (7.93mm)
MIN. PUNCH DIAMETER:	.0937" (2.38mm)
MAX. SQUARE:	N.A.
MIN. SHAPE DIMENSION:	N.A.
MAX. MATERIAL THICKNESS (STAINLESS STEEL):	1/16" (1.6mm)

BX-3/4" 19mm width

	ROUND UNITS		COMMON DIMENSIONS		
	Model No.	Part No.	Throat Depth	Length A	Shipping Weight
BASE UNITS LESS PUNCH & DIE	4BX-3/4-LPD	3000-LPD	4"	7"	5.75 lbs.
	8BX-3/4-LPD	3001-LPD	8"	11"	7.75 lbs.
COMPLETE UNITS (Includes Punch & Die)	4BX-3/4	3000	4"	7"	6 lbs.
	8BX-3/4	3001	8"	11"	8 lbs.

BX KITS AND SHIMS

Key kit:	N.A.
Hardware kit:	9370
Punch shim:	1089-12 pk. 1089-48 pk. 1/16" thk./3 max.
Die shim:	N.A.
Upper arm kit:	9761

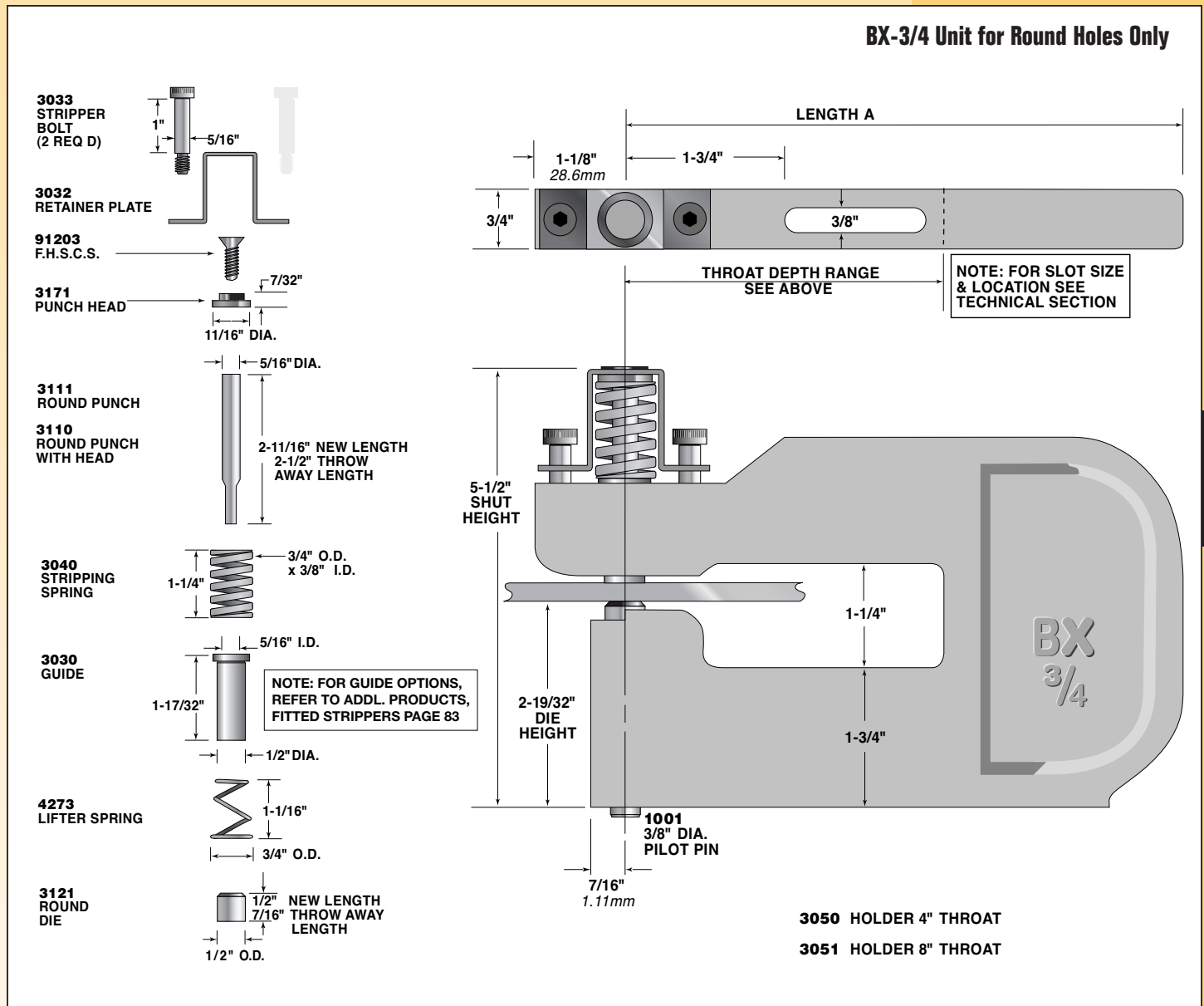

B SERIES

SPECIFICATIONS & OPERATING INSTRUCTIONS

OPERATING SHUT HEIGHT:	5-1/2" (139.7mm)
MIN. SHUT HEIGHT:	5-5/16" (134.9mm)
UNIT OPEN HEIGHT:	5-7/8" (149.2mm)
DIE HEIGHT:	2-19/32" (65.9mm)
MATERIAL FEED CLEARANCE:	7/32" (5.5mm)
MAX. MATERIAL THICKNESS (MILD STEEL):	10 GA. /.134" (3.4mm)

MIN. DIE CLEARANCE:	.006" (.15mm)
MAX. PUNCH DIAMETER:	.3750" (9.52mm)
MIN. PUNCH DIAMETER:	.0937" (2.38mm)
MAX. SQUARE:	.265" (6.73mm)
MIN. SHAPE DIMENSION:	.0937" (2.38mm)
MAX. MATERIAL THICKNESS (STAINLESS STEEL):	1/16" (1.6mm)

B-1 1/4"

31.8mm width

	ROUND UNITS		*SHAPED UNITS		COMMON DIMS.		
	Model No.	Part No.	Model No.	Part No.	Throat Depth	Length A	Shipping Weight
BASE UNITS LESS PUNCH & DIE	4B-1 1/4-LPD	3303-LPD	4SB-1 1/4-LPD	3305-LPD	4"	7"	8 lbs.
	8B-1 1/4-LPD	3300-LPD	8SB-1 1/4-LPD	3306-LPD	8"	11"	11 lbs.
	12B-1 1/4-LPD	3301-LPD	12SB-1 1/4-LPD	3307-LPD	12"	15"	15 lbs.
COMPLETE UNITS (Includes Punch & Die)	4B-1 1/4	3303	4SB-1 1/4	3305	4"	7"	8.5 lbs.
	8B-1 1/4	3300	8SB-1 1/4	3306	8"	11"	11.5 lbs.
	12B-1 1/4	3301	12SB-1 1/4	3307	12"	15"	15.5 lbs.

*To order a shaped unit with round punch & die, add the suffix "- RPD"

KITS AND SHIMS

Shaped hole conversion kit:	7135
Key kit:	9317
Hardware kit:	9372
Punch shim:	1080-12 pk. 1080-48 pk. 1/16" thk./3 max.
Die shim:	1091-12 pk. 1091-48 pk. 1/16" thk./3 max.
Upper arm kit:	9763 Round 9764 Shaped

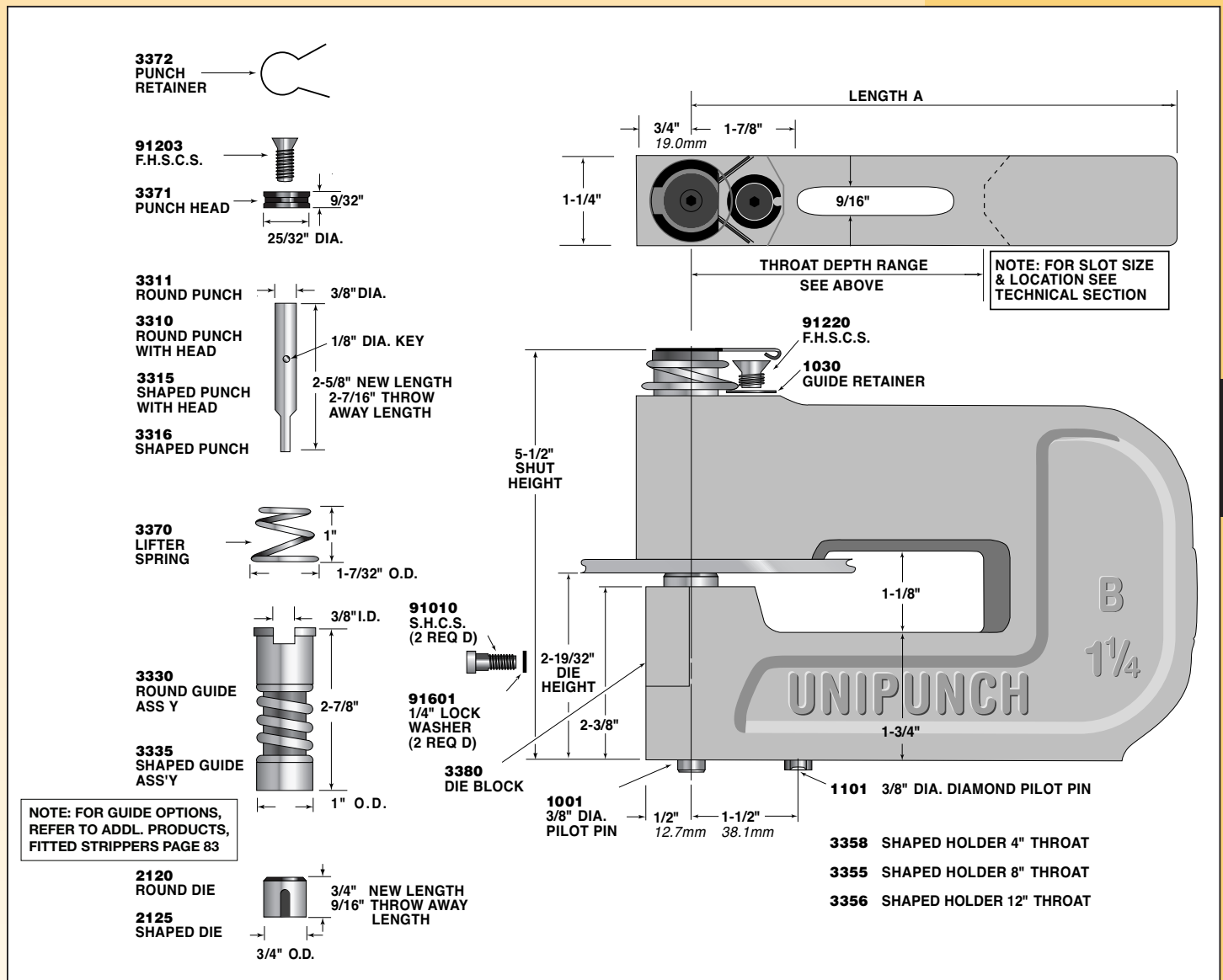

B SERIES

B-1³/₄"

44.5mm width

SPECIFICATIONS & OPERATING INSTRUCTIONS

OPERATING SHUT HEIGHT:	5-1/2" (139.7mm)
MIN. SHUT HEIGHT:	5-5/16" (134.9mm)
UNIT OPEN HEIGHT:	5-7/8" (149.2mm)
DIE HEIGHT:	2-19/32" (65.9mm)
MATERIAL FEED CLEARANCE:	7/32" (5.5mm)
MAX. MATERIAL THICKNESS (MILD STEEL):	10 GA. / .134" (3.4mm)

MIN. DIE CLEARANCE:	.006" (.15mm)
MAX. PUNCH DIAMETER:	.5000" (12.70mm)
MIN. PUNCH DIAMETER:	.1250" (3.18mm)
MAX. SQUARE:	.353" (8.96mm)
MIN. SHAPE DIMENSION:	.0937" (2.38mm)
MAX. MATERIAL THICKNESS (STAINLESS STEEL):	1/16" (1.6mm)

KITS AND SHIMS

Shaped hole conversion kit:	7136
Key kit:	9317
Hardware kit:	9372
Punch shim:	1081-12 pk. 1081-48 pk. 1/16" thk./3 max.
Die shim:	1091-12 pk. 1091-48 pk. 1/16" thk./3 max.
Upper arm kit:	9765 Round 9766 Shaped

	ROUND UNITS		*SHAPED UNITS		COMMON DIMS.		
	Model No.	Part No.	Model No.	Part No.	Throat Depth	Length A	Shipping Weight
BASE UNITS LESS PUNCH & DIE	4B-1 ³ / ₄ -LPD	3403-LPD	4SB-1 ³ / ₄ -LPD	3405-LPD	4"	7"	13.5 lbs.
	8B-1 ³ / ₄ -LPD	3400-LPD	8SB-1 ³ / ₄ -LPD	3406-LPD	8"	11"	17.5 lbs.
	12B-1 ³ / ₄ -LPD	3401-LPD	12SB-1 ³ / ₄ -LPD	3407-LPD	12"	15"	20 lbs.
COMPLETE UNITS (Includes Punch & Die)	4B-1 ³ / ₄	3403	4SB-1 ³ / ₄	3405	4"	7"	14 lbs.
	8B-1 ³ / ₄	3400	8SB-1 ³ / ₄	3406	8"	11"	18 lbs.
	12B-1 ³ / ₄	3401	12SB-1 ³ / ₄	3407	12"	15"	21.5 lbs.

*To order a shaped unit with round punch & die, add the suffix "- RPD"

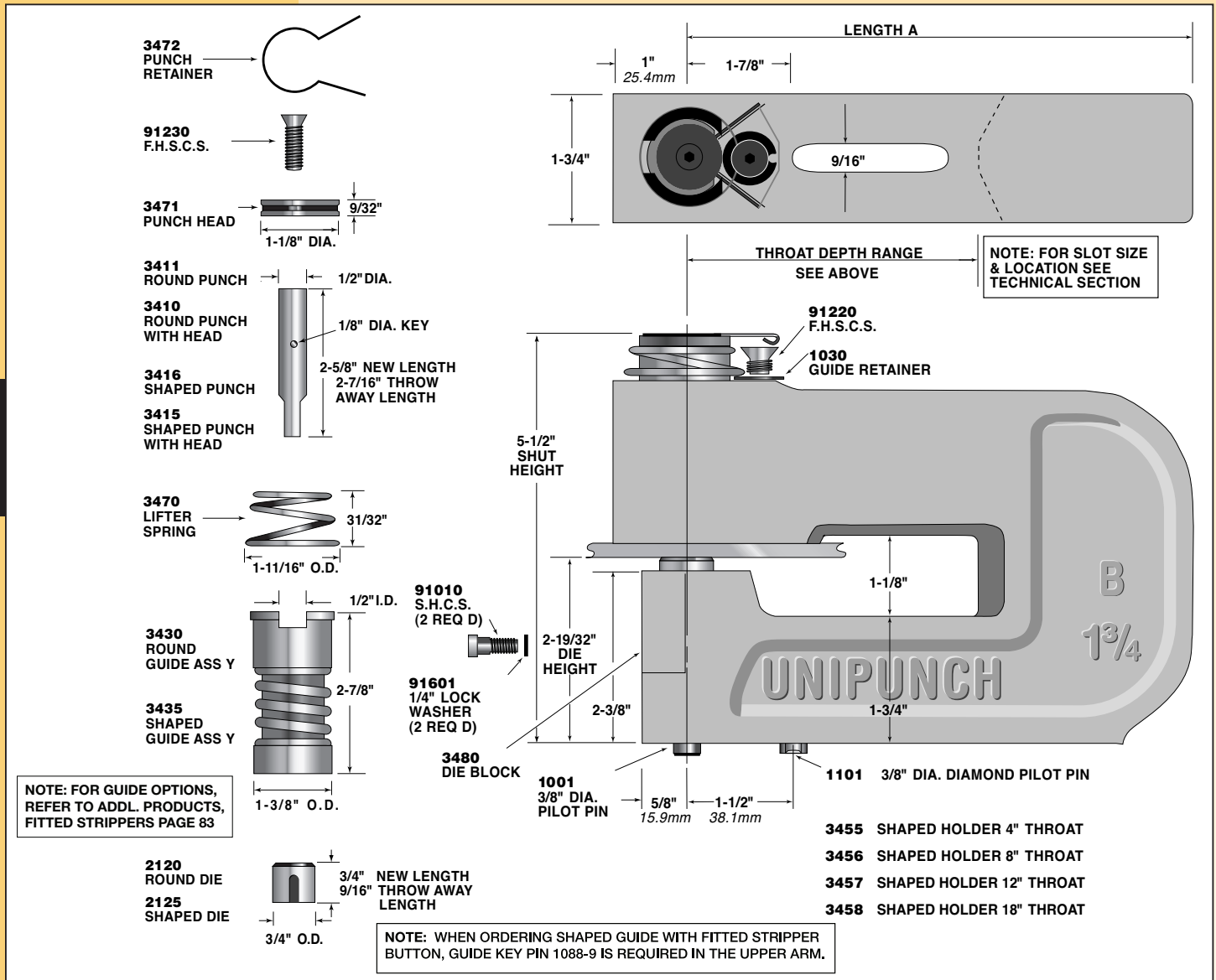

B SERIES

SPECIFICATIONS & OPERATING INSTRUCTIONS

OPERATING SHUT HEIGHT:	5-1/2" (139.7mm)
MIN. SHUT HEIGHT:	5-5/16" (134.9mm)
UNIT OPEN HEIGHT:	5-7/8" (149.2mm)
DIE HEIGHT:	2-19/32" (65.9mm)
MATERIAL FEED CLEARANCE:	7/32" (5.5mm)
MAX. MATERIAL THICKNESS (MILD STEEL):	10 GA. / .134" (3.4mm)

MIN. DIE CLEARANCE:	.006" (.15mm)
MAX. PUNCH DIAMETER:	1.000" (25.40mm)
MIN. PUNCH DIAMETER:	.250" (6.35mm)
MAX. SQUARE:	.707" (17.96mm)
MIN. SHAPE DIMENSION:	.0937" (2.38mm)
MAX. MATERIAL THICKNESS (STAINLESS STEEL):	1/16" (1.6mm)

BX-2 1/4

57mm width

	ROUND UNITS		*SHAPED UNITS		COMMON DIMS.		
	Model No.	Part No.	Model No.	Part No.	Throat Depth	Length A	Shipping Weight
BASE UNITS LESS PUNCH & DIE	4BX-2 1/4-LPD	3542-LPD	4SBX-2 1/4-LPD	3546-LPD	4"	7"	17 lbs.
	8BX-2 1/4-LPD	3543-LPD	8SBX-2 1/4-LPD	3547-LPD	8"	11"	24 lbs.
	12BX-2 1/4-LPD	3544-LPD	12SBX-2 1/4-LPD	3548-LPD	12"	15"	29.5 lbs.
COMPLETE UNITS (Includes Punch & Die)	4BX-2 1/4	3542	4SBX-2 1/4	3546	4"	7"	18 lbs.
	8BX-2 1/4	3543	8SBX-2 1/4	3547	8"	11"	24.5 lbs.
	12BX-2 1/4	3544	12SBX-2 1/4	3548	12"	15"	30 lbs.

*To order a shaped unit with round punch & die, add the suffix "- RPD"

KITS AND SHIMS

Shaped hole conversion kit:	7137
Key kit:	9317
Hardware kit:	9374
Punch shim:	1082-12 pk. 1082-48 pk. 1/16" thk./3 max.
Die shim:	1194-12 pk. 1194-48 pk. 1/16" thk./1 max.
Upper arm kit:	9767 Round 9768 Shaped

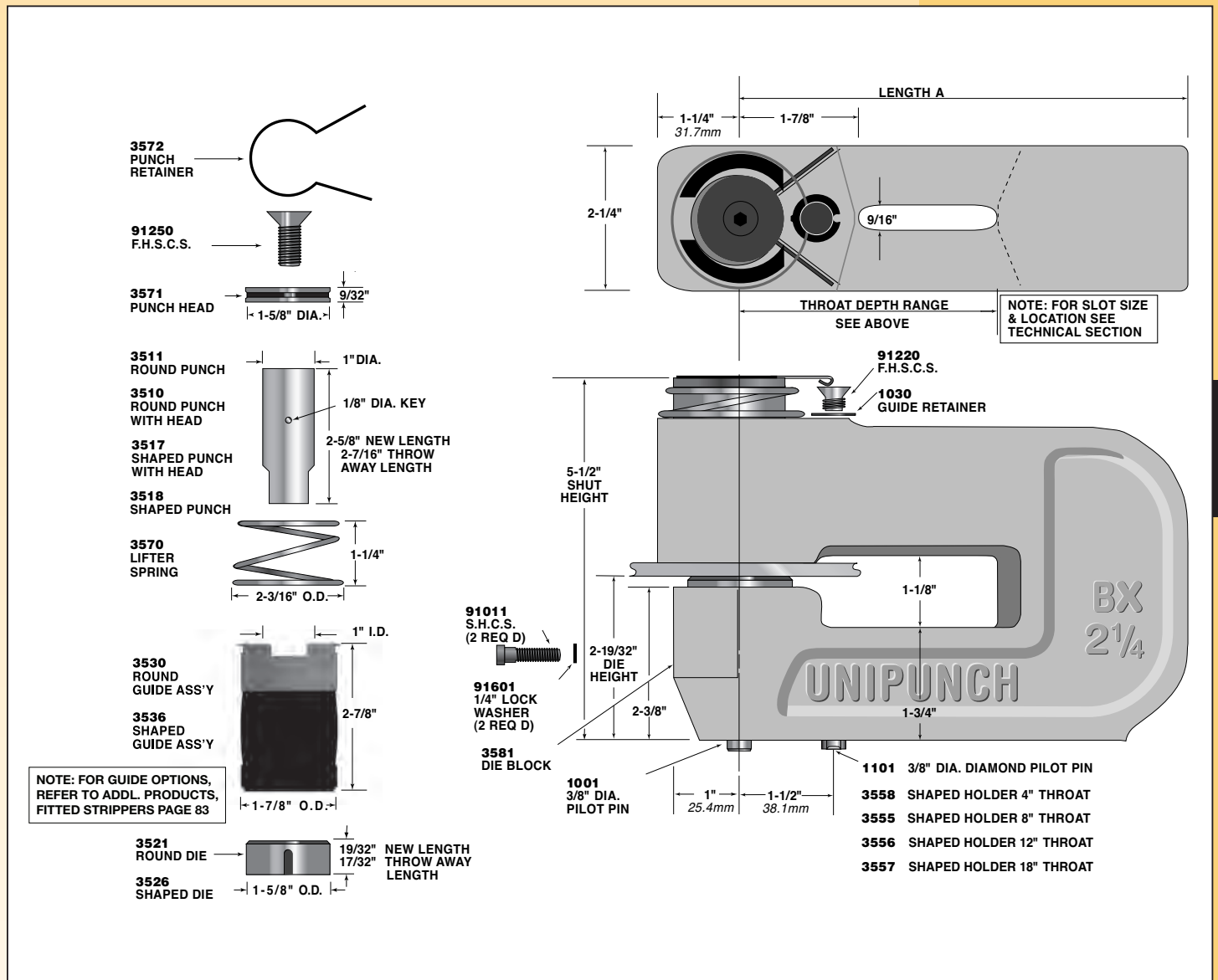

B SERIES

B-3[™]

76.2mm width

SPECIFICATIONS & OPERATING INSTRUCTIONS

OPERATING SHUT HEIGHT:	5-1/2" (139.7mm)	MIN. DIE CLEARANCE:	.006" (.15mm)
MIN. SHUT HEIGHT:	5-5/16" (134.9mm)	MAX. PUNCH DIAMETER:	2.000" (50.80mm)
UNIT OPEN HEIGHT:	5-7/8" (149.2mm)	MIN. PUNCH DIAMETER:	.5000" (12.7mm)
DIE HEIGHT:	2-19/32" (65.9mm)	MAX. SQUARE:	1.414" (35.9mm)
MATERIAL FEED CLEARANCE:	7/32" (5.5mm)	MIN. SHAPE DIMENSION:	.1250" (3.18mm)
MAX. MAT. THK. (M.S.):	10GA. / .134" (3.4mm)	MAX. MAT. THK. (S.S.):	1/16" (1.6mm)

KITS AND SHIMS

Shaped hole conversion kit:	7138
Key kit:	9300
Hardware kit:	9375
Punch shim:	1112-12pk. 1112-48pk. 1/16" thk./1 max.
Die shim:	1096 1/16" thk./3 max.

	ROUND UNITS		*SHAPED UNITS		COMMON DIMS.		
	Model No.	Part No.	Model No.	Part No.	Throat Depth	Length A	Shipping Weight
BASE UNITS LESS PUNCH & DIE	8B-3-LPD	3600-LPD	8SB-3-LPD	3606-LPD	8"	11"	27 lbs.
	12B-3-LPD	3601-LPD	12SB-3-LPD	3607-LPD	12"	15"	34 lbs.
COMPLETE UNITS (Includes Punch & Die)	8B-3	3600	8SB-3	3606	8"	11"	28.5 lbs.
	12B-3	3601	12SB-3	3607	12"	15"	35.5 lbs.

*To order a shaped unit with round punch & die, add the suffix "- RPD"

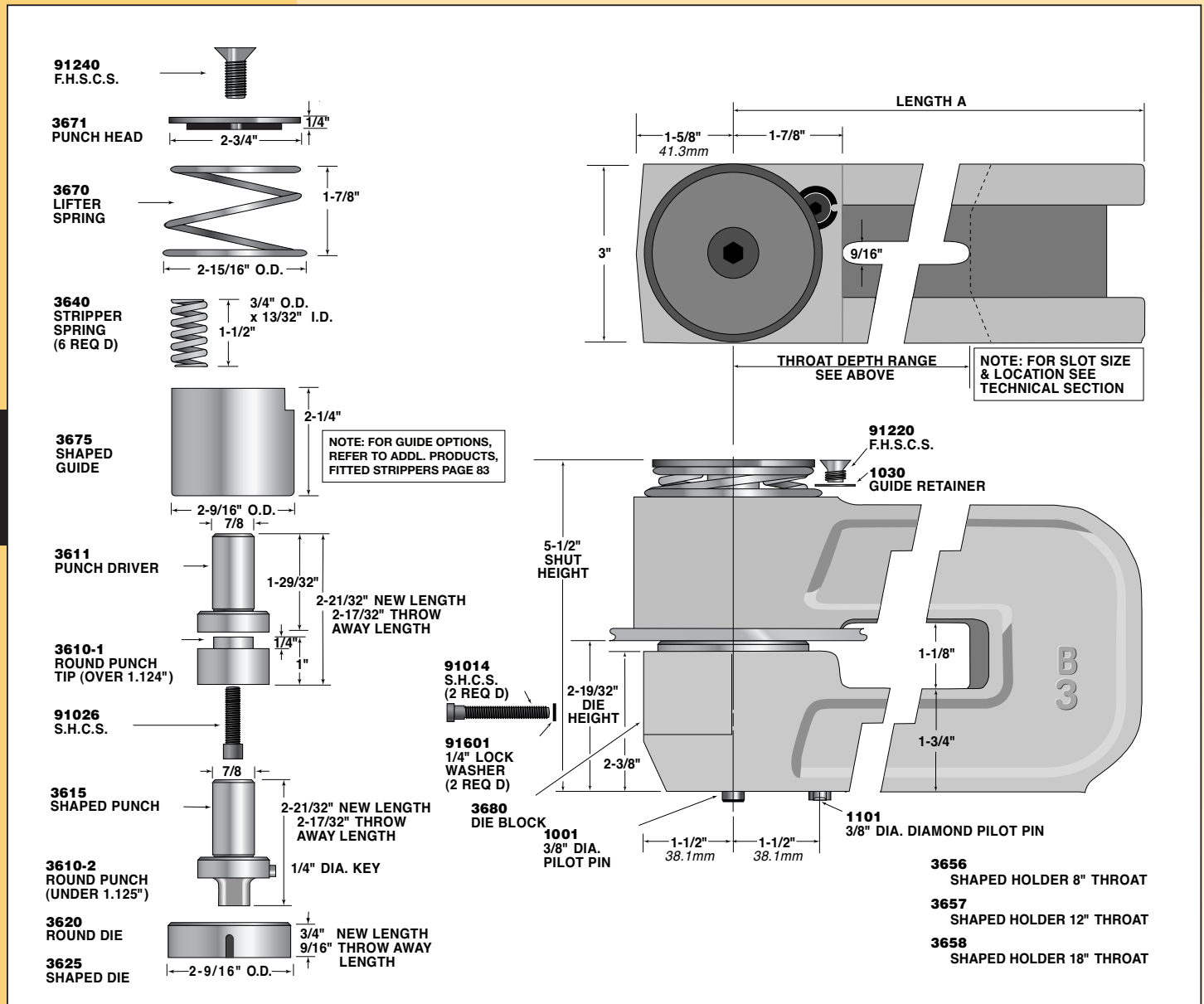

B SERIES

SPECIFICATIONS & OPERATING INSTRUCTIONS

OPERATING SHUT HEIGHT:	5-1/2" (139.7mm)	MIN. DIE CLEARANCE:	.008" (.2mm)
MIN. SHUT HEIGHT:	5-5/16" (134.9mm)	MAX. PUNCH DIAMETER:	3.500" (88.90mm)
UNIT OPEN HEIGHT:	5-7/8" (149.2mm)	MIN. PUNCH DIAMETER:	1.000" (25.40mm)
DIE HEIGHT:	2-19/32" (65.9mm)	MAX. SQUARE:	2.474" (62.84mm)
MATERIAL FEED CLEARANCE:	7/32" (5.5mm)	MIN. SHAPE DIMENSION:	.1250" (3.18mm)
MAX. MAT. THK. (M.S.):	10GA./134" (3.4mm)	MAX. MAT. THK. (S.S.):	1/16" (1.6mm)

B-5[™]

127mm width

	ROUND UNITS		*SHAPED UNITS		COMMON DIMS.		
	Model No.	Part No.	Model No.	Part No.	Throat Depth	Length A	Shipping Weight
BASE UNITS LESS PUNCH & DIE	8B-5-LPD	3800-LPD	8SB-5	3805-LPD	8¼"	11¾"	50 lbs.
	12B-5-LPD	3801-LPD	12SB-5	3806-LPD	12¼"	15¾"	65 lbs.
COMPLETE UNITS (Includes Punch & Die)	8B-5	3800	8SB-5	3805	8¼"	11¾"	55 lbs.
	12B-5	3801	12SB-5	3806	12¼"	15¾"	70 lbs.

To order a shaped unit with round punch & die, add the suffix "- RPD"

KITS AND SHIMS

Shaped hole conversion kit:	N.A.
Key kit:	9318
Hardware kit:	9376
Punch shim:	1113-12 pk. 1113-48 pk. 1/16" thk./3 max.
Die shim:	1128 1/16" thk./3 max.

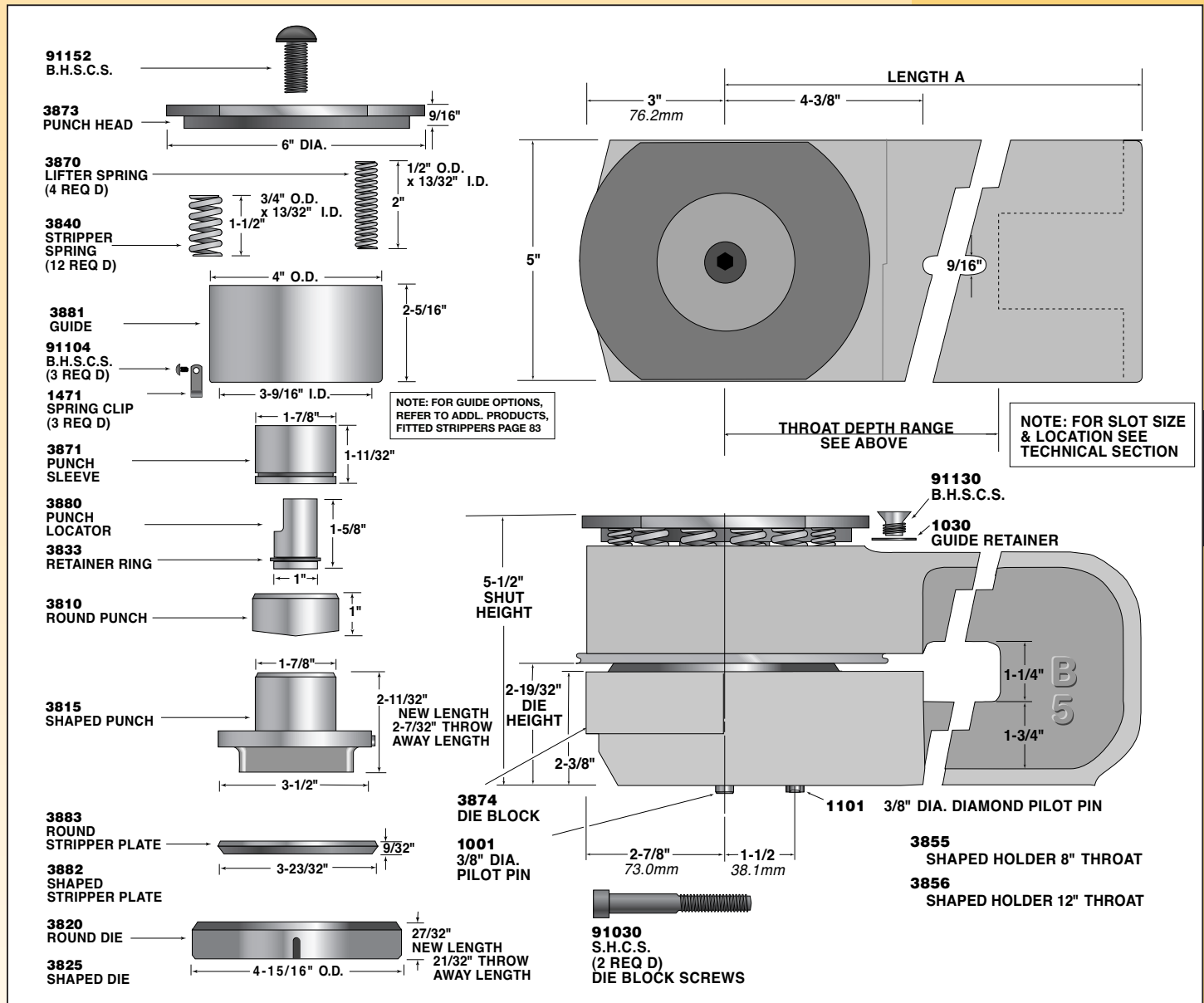

B SERIES

B SERIES Corner NOTCH

SPECIFICATIONS & OPERATING INSTRUCTIONS

OPERATING SHUT HEIGHT: 5-1/2" (139.7mm)
 MIN. SHUT HEIGHT: 5-5/16" (134.9mm)
 UNIT OPEN HEIGHT: 5-7/8" (149.2mm)
 DIE HEIGHT: 2-19/32" (65.9mm)
 MAX. MATERIAL THICKNESS
 (MILD STEEL): 10 GA./.134" (3.4mm)

MATERIAL FEED CLEARANCE: 3/16" (4.8mm)
 MIN. DIE CLEARANCE: Die Clearance is
 preset at factory
 for notching from
 22 GA./.030" (.76mm)
 MAX. MATERIAL THICKNESS
 (STAINLESS STEEL): 1/16" (1.6mm)

Note: All Corner Notching Units have replaceable punch and die steels.

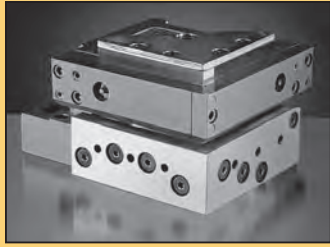

NOTCHING UNITS

Type	Part No.	Max. Notch Dia.	Ship. Wt.
L.H.	7010	5" x 5"	60 lbs.
	7040	3" x 3"	35 lbs.
R.H.	7020	5" x 5"	60 lbs.
	7050	3" x 3"	35 lbs.

B Series – Corner Notch Units: 5" x 5" and 3" x 3"

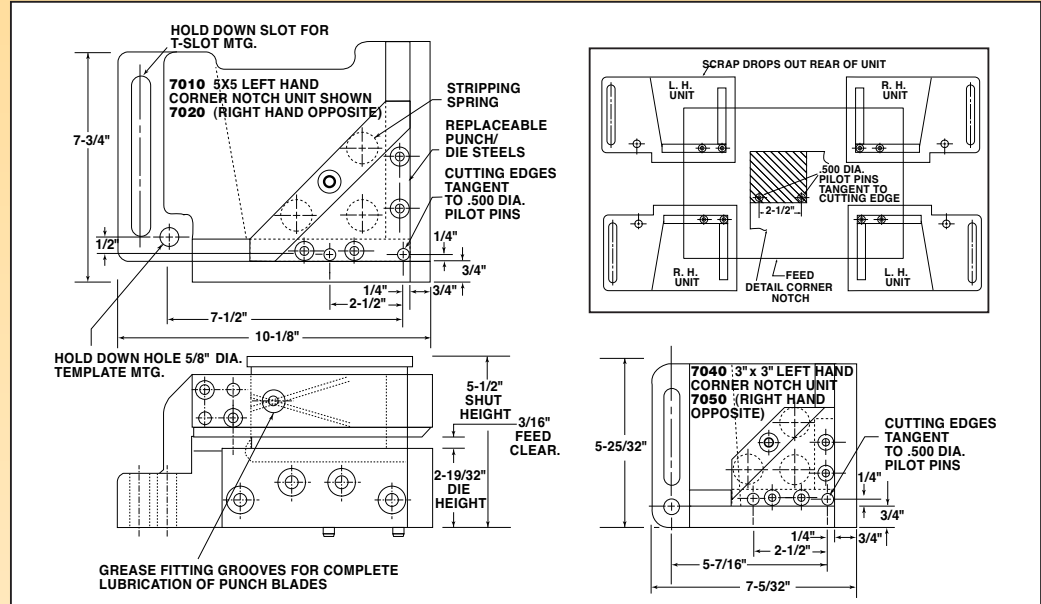

		7010	7020	7040	7050
Item No.	Parts Description	Part No.	Part No.	Part No.	Part No.
1	Punch Blade (long)	7091	7091	7004	7004
2	Punch Blade (short)	7090	7090	7003	7003
3	Punch Plate	6074	6074	7039	7039
4	Die Steel (side)	—	—	7044	7045
4A	Die Steel (long)	6080	6081	—	—
5	Die Steel (front)	—	—	7046	7047
5A	Die Steel (short)	6082	6083	—	—
6	Set of Die Screws	6002 (set of 8)	6002 (set of 8)	7052 (set of 6)	7052 (set of 6)
7	Spring (3 req'd)	7540	7540	7540	7540
8	Spring Cage	7043	7043	7043	7043
9	Retainer	2476	2476	2476	2476
10	Stripper Bolt	91400	91400	91400	91400
11	Round Pilot Pin	1006	1006	1006	1006
12	Diamond Pilot Pin	1116	1116	1116	1116
13	Punch Plate Screw	91080	91080	91077	91077

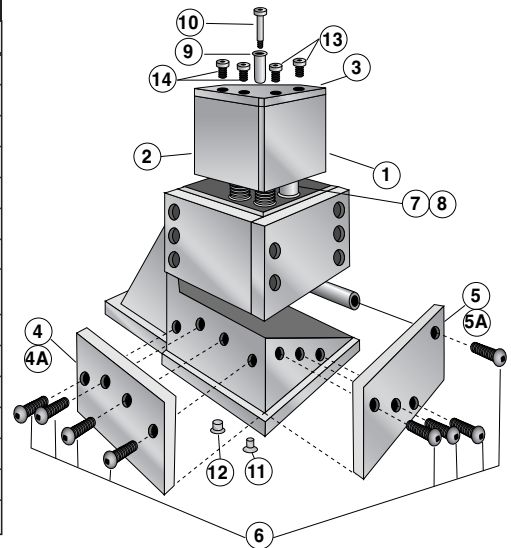

6060 and 6050 Gauging Methods



Gauging plate with built-in scales and adjustable stops.
Part No. 6060



Adjustable side gauges for each cutting side.
Set of 2
Part No. 6050

SPECIFICATIONS & OPERATING INSTRUCTIONS

OPERATING SHUT HEIGHT:	5-1/2" (139.7mm)
MIN. SHUT HEIGHT:	5-5/16" (134.9mm)
UNIT OPEN HEIGHT:	5-7/8" (149.2mm)
DIE HEIGHT:	2-19/32" (65.9mm)
MIN. MATERIAL THICKNESS:	22 GA. (.76mm)

MIN. DIE CLEARANCE:	Die Clearance is preset at factory
MAX. MATERIAL THICKNESS (MILD STEEL):	10 GA. / .134" (3.4mm)
MAX. MATERIAL THICKNESS (STAINLESS STEEL):	1/16" (1.6mm)

7180

Corner Notch Unit

7180 "B" Series 8" x 8" / 90° Corner Notch Unit

COMPLETE UNIT	COMMON DIMENSIONS		
Part No.	Max. Notch (Corner)	Max. 'V' Notch	Shipping Weight
7180	8" x 8" / 90°	5 1/2" Deep / 90°	168 lbs.

Note: Punch & die steels in 7180 Corner Notch Units are not interchangeable. Unit must be returned to factory for replacement. Spare punch & die steels can be supplied with new units.

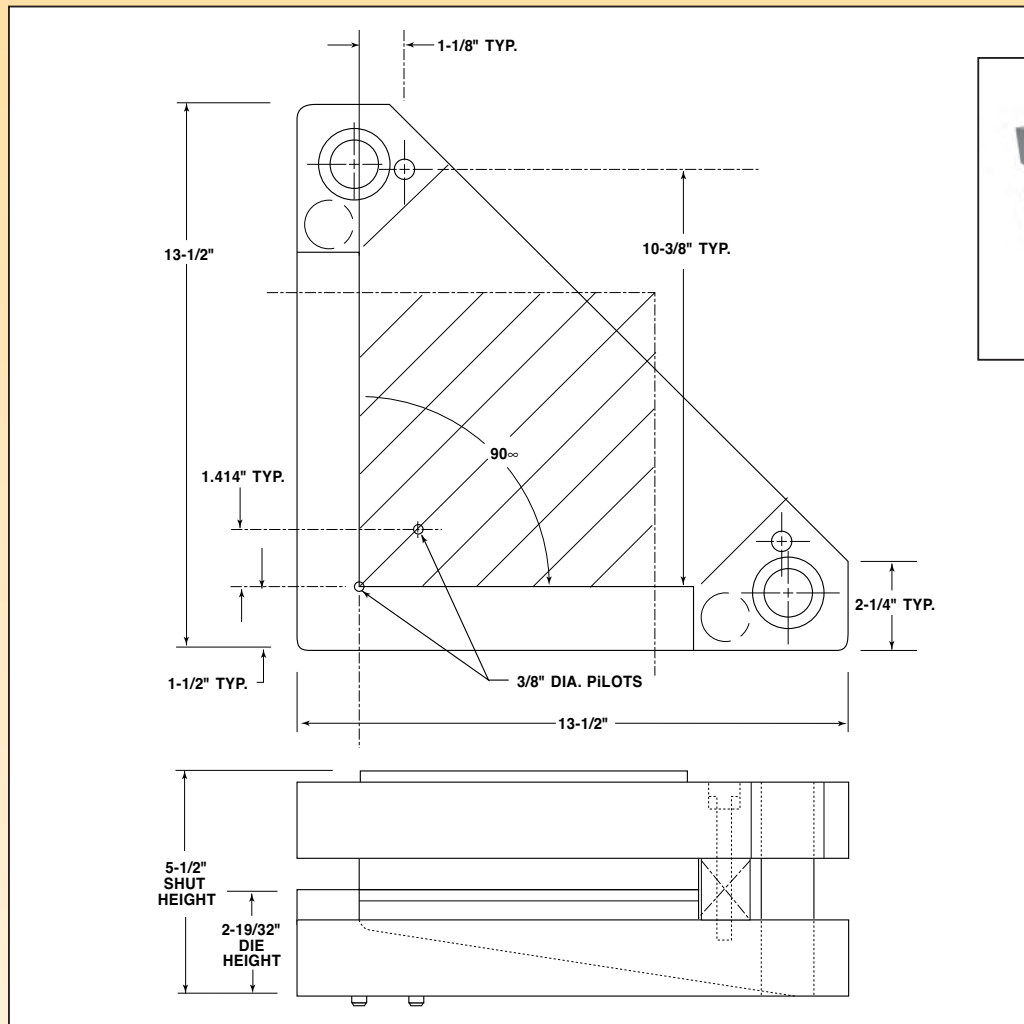

The "B" series 8" x 8" Notch Unit has been designed to produce notch sizes greater than our standard 5" x 5" Corner Notch Units. The unit is completely compatible with all of the products in our "B" Series. Gauges sold separately. See below.

Gauges for 7180 Notching Unit

GAUGE ASSEMBLY WITH BUILT IN SCALES AND ADJUSTABLE STOPS
Part No.
7160*

*Includes mounting screws for attachment to holder and gauge plates.



B SERIES

5300

Flat Stock Cutoff Units

UniPunch "B" Series 5300 Flat Stock Cutoff Units are self-contained two post die shearing units available in widths up to 8" (203.2mm). These units can be mounted in a press or press brake adjacent to existing C-frame tooling or used in stand-alone cut-to-length applications in mild steel up to 10 gauge / .134" (3.4mm) mild steel. Other widths can be manufactured to your requirements.

SPECIFICATIONS & OPERATING INSTRUCTIONS

OPERATING SHUT HEIGHT:	5-1/2" (139.7mm)
MIN. SHUT HEIGHT:	5-5/16" (134.9mm)
UNIT OPEN HEIGHT:	5-7/8" (149.2mm)
DIE HEIGHT:	2-19/32" (65.9mm)
MIN. MATERIAL THICKNESS:	22 GA. (.76mm)

MIN. DIE CLEARANCE:	Die Clearance is preset at factory
MAX. MATERIAL THICKNESS (MILD STEEL):	10 GA./ .134" (3.4mm)
MAX. MATERIAL THICKNESS (STAINLESS STEEL):	1/16" (1.6mm)

COMPLETE UNITS	
Part No.	
5300-200	
5300-400	
5300-600	
5300-800	

COMMON DIMENSIONS				
Max. Cutoff Width A	B	C	Max. Tonnage	Shipping Weight
2"	10 1/2"	9 1/4"	8	55.5 lbs.
4"	12 1/2"	11 1/4"	15	66 lbs.
6"	14 1/2"	13 1/4"	23	77 lbs.
8"	16 1/2"	15 1/4"	30	87.25 lbs.

Note: For sizes not shown, contact UniPunch Sales Department for application information and pricing.

Note: Punch & die steels in Flat Stock Cutoff Units are not interchangeable. Units must be returned to factory for replacement. Spare punch & die steels can be supplied with new units.

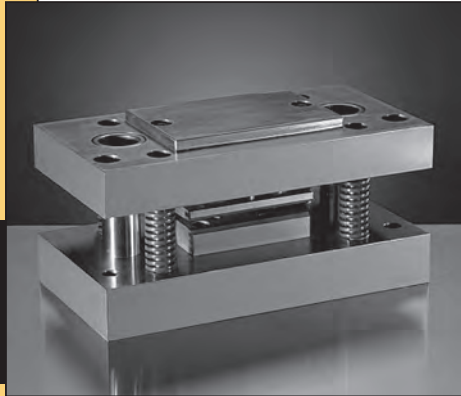

B SERIES

9/16" WIDE HOLD DOWN SLOTS

3/8" DIA. PILOT PINS

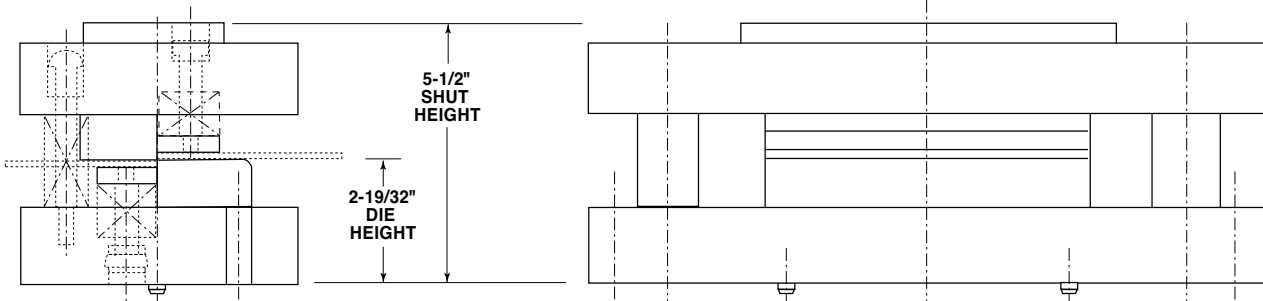
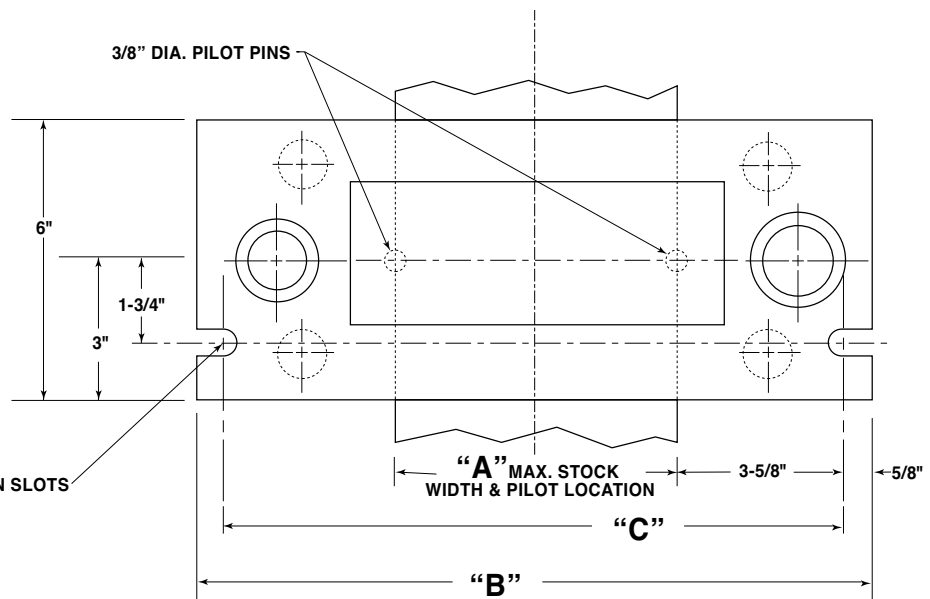

SPECIFICATIONS & OPERATING INSTRUCTIONS

OPERATING SHUT HEIGHT:	5-1/2" (139.7mm)
MIN. SHUT HEIGHT:	5-5/16" (134.9mm)
UNIT OPEN HEIGHT:	5-7/8" (149.2mm)
DIE HEIGHT:	2-19/32" (65.9mm)
MATERIAL FEED CLEARANCE:	7/32" (5.5mm)

UNIT CAP.:	1/16" (1.6mm) to 1/4" (6.4mm) radius 14 GA. mild steel (1.9mm) .032 stainless steel (.81mm)
UNIT CAP.:	5/16" (7.9mm) to 1/2" (12.7mm) radius 10 GA. mild steel (3.4mm) 16 GA. stainless steel (1.6mm)
RADIUS SIZES:	SET #1-1/16, 1/8, 3/16 & 1/4" rad. (1.6, 3.1, 4.8, 6.4mm) SET #2-5/16, 3/8, 7/16 & 1/2" rad. (7.9, 9.5, 11.1, 12.7mm)

4000

Radius Unit

For Radii from 1/16" (1.6mm)
to 1/2" (12.7mm)

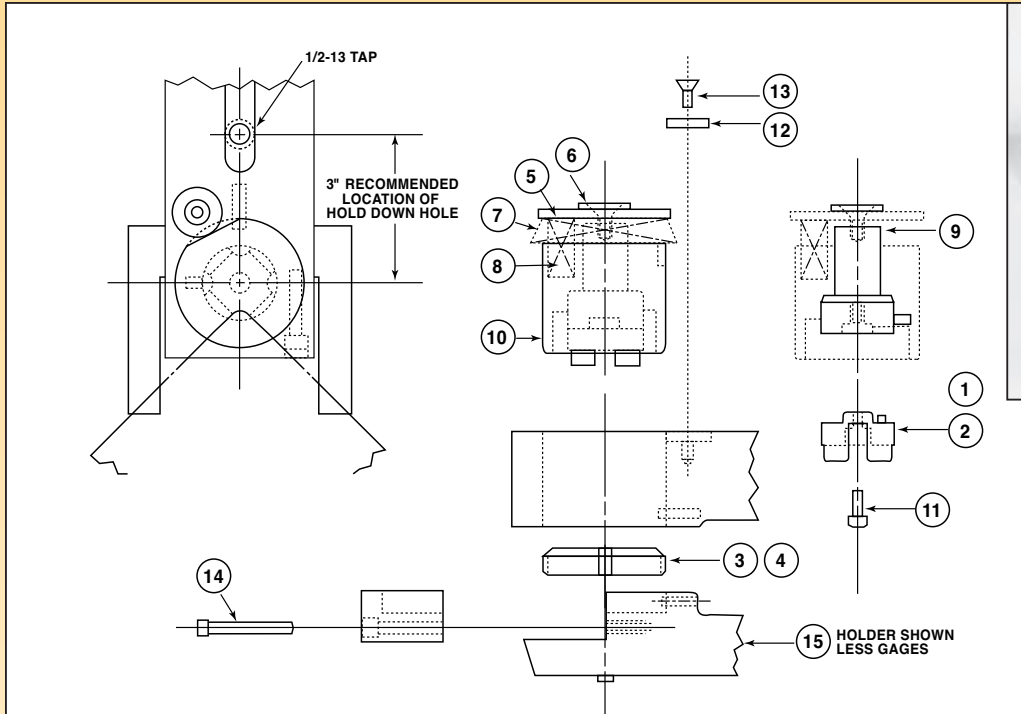

The UniPunch 4000 Unit is designed to radius trim the corners of parts (e.g. in manufacturing signs, road markers or cover plates).

This stand-alone radius unit is furnished complete with built-in squaring guides for gauging 90 degree part blanks. Two punch and die sets are available to produce eight common radii. See specifications for Set #1 or Set #2.

Radius sizes can be selected simply by rotating the punch and die assembly. The die clearance is preset for trimming mild steel up to 10 gauge thick.

ITEM	DESCRIPTION	PART No.
A	Unit Complete with Punch & Die Sets for four standard radii with Set #1 - 1/16", 1/8", 3/16" and 1/4" Radius	4000-1
B	Unit Complete with Punch & Die Sets for four standard radii with Set #2 - 5/16", 3/8", 7/16" and 1/2" Radius	4000-2
C	Unit Complete with Punch & Die Sets for eight standard radii with Sets #1 & 2	4000
1	Punch for radii from 1/16" thru 1/4"	4025-100
2	Punch for radii from 5/16" thru 1/2"	4050-100
3	Die for radii from 1/16" thru 1/4"	4025-200
4	Die for radii from 5/16" thru 1/2"	4050-200
5	Punch Head	3671
6	Punch Screw	91240
7	Lifter Spring	3670
8	Stripping Spring (set of 3)	3642
9	Punch Adapter	4015
10	Guide	4035
11	Screw (Punch Tip)	91010
12	Guide Retainer	1030
13	Screw (Guide Retainer)	91220
14	Screw (Die Block) (2 Req'd)	91014
15	Special Holder Only (Including Gauging Plates)	4056



4000 Radius Tool
Punch and Die

SPEED WITHIN REACH
UNIPUNCH

B SERIES

G Series

G - Triple Spring Unit

- 7-1/2" shut height
- Material Thickness up to 3/16"
- Adjustable punch head extends tool life

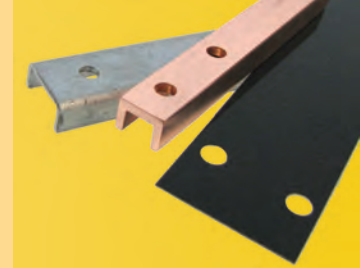

G Units (Page 70)

The UniPunch 'G' Series Triple Spring Unit has a 7½" shut height. They are designed for round hole punching. The advantage of the Triple Spring Unit comes from the additional stripping spring force that allows the unit to be used to punch .3125" round holes in 3/16" material. (For thicker punching applications, see the "A" or "B" series.)

G - Triple Spring

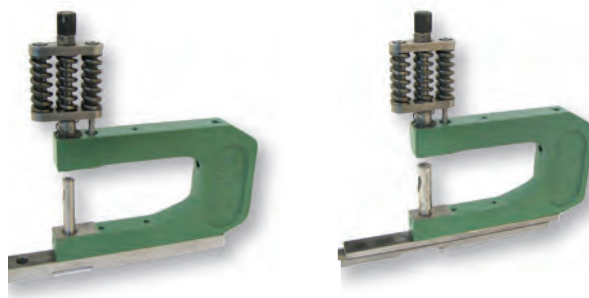

Fixed Base

Adjustable Base

The G series units are mounted to the UniPunch 5110 bed rail with either the fixed base or the adjustable base. The fixed base is designed for straight line punching. The adjustable base allows 3/4" adjustment front to back (a total of 1 ½").

G Series Usage

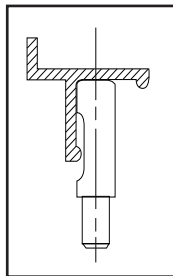

'G' Series units are designed for punching holes as close as ¾" center-to-center. These units feature a pedestal die which is an advantage for punching formed parts such as aluminum extrusions, roll formed parts and small channels and angles because the pedestal die can be modified to accommodate the profile of the part.

(For flat parts with close hole centers, UniPunch recommends the BX-3/4 because it can be used alongside other B series units. (See page 55). The G-3/4 units are commonly used by storm door and window manufacturers and in the recreational vehicle industry and by fabricators of other aluminum extrusions.

PRESS BRAKE MOUNTING ACCESSORIES FOR ALL G SERIES UNITS

RAM PLATE (6" WIDE X 3/4" THICK)			BED RAIL G SERIES		
Part No.	Length	Shipping Weight	Part No.	Length	Shipping Weight
5019-24	24"	33 lbs.	5110-48	48"	92 lbs.
5019-48	48"	56 lbs.	5110-72	72"	138 lbs.
5019-72	72"	84 lbs.	5110-96	96"	184 lbs.
5019-96	96"	112 lbs.	5110-120	120"	230 lbs.
5019-120	120"	140 lbs.	5110-144	144"	276 lbs.
5019-144	144"	168 lbs.			



Triple Spring Unit Press Brake mounting method shown

Single spring unit mounted in the same method and operates at 6 1/4" shut height.

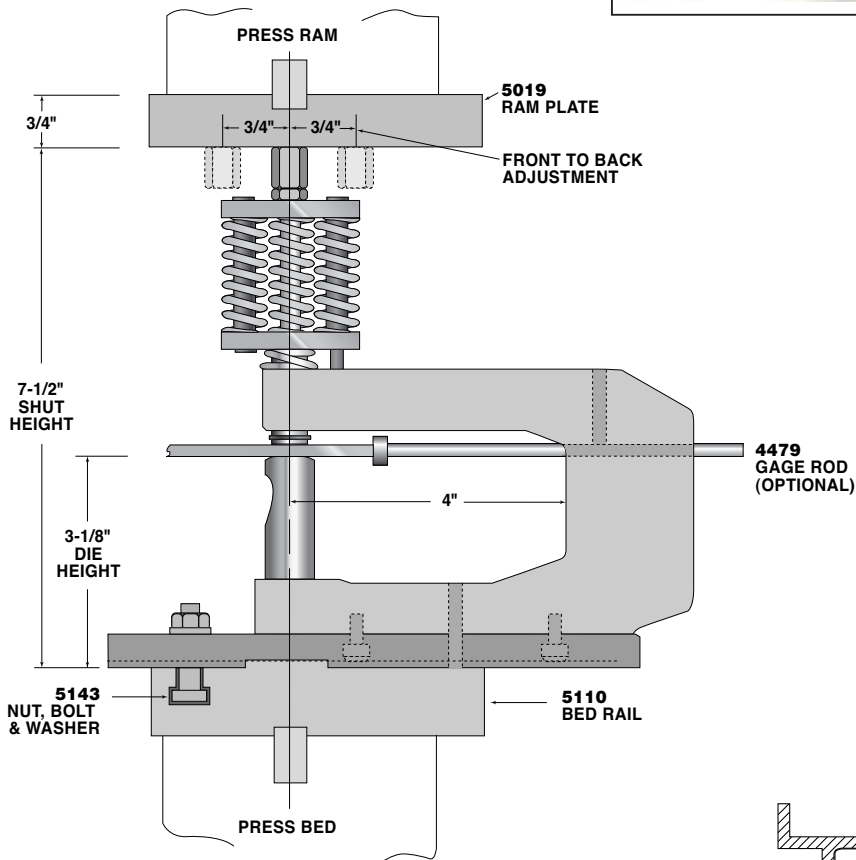

The G series units are mounted to the UniPunch 5110 bed rail with either the fixed base or the adjustable base. The fixed base is designed for straight line punching. The adjustable base allows 3/4" adjustment front to back (a total of 1 1/2").

TYPICAL SPECIAL DIE
Made to suit customer requirements

NUT, BOLT AND WASHER SET

Part No.
5143

END GAUGE ASSEMBLY

Part No.
5085



Adjustable End Stop has an adjustment screw for quick compensation for various work piece sizes.

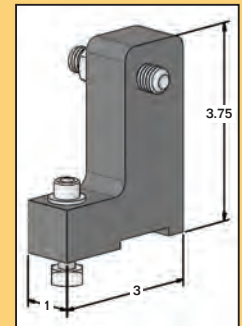

Triple Spring Unit
G-3/4"
 19.0 mm width

SPECIFICATIONS & OPERATING INSTRUCTIONS

OPERATING SHUT HEIGHT:	7-1/2" (190.50mm)
MIN. SHUT HEIGHT:	7-5/16" (185.72mm)
UNIT OPEN HEIGHT:	8" (203.2mm)
DIE HEIGHT:	3-1/8" (79.4mm)
MAX. MATERIAL THICKNESS (MILD STEEL):	3/16" (4.8mm)

MATERIAL FEED CLEARANCE:	3/16" (4.8mm)
MIN. DIE CLEARANCE:	.006" (.15mm)
MAX. PUNCH DIAMETER:	.3125" (7.94mm)
MIN. PUNCH DIAMETER:	.0937" (2.38mm)
MAX. MATERIAL THICKNESS (STAINLESS STEEL):	.062" (1.57mm)

KITS AND SHIMS

Hardware kit:	9385
Punch shim:	N.A.
Die shim:	N.A.

	COMPLETE ROUND UNITS		COMMON DIMENSIONS	
	Model No.	Max. Punch Diameter	Throat Depth	Shipping Weight
UNITS WITH FIXED BASE	G-4221	.156	4"	7 lbs.
	G-4222	.250	4"	7 lbs.
	G-4226	.3125	4"	7 lbs.
UNITS WITH ADJUSTABLE BASE	GA-4221	.156	4"	7 lbs.
	GA-4222	.250	4"	7 lbs.
	GA-4226	.3125	4"	7 lbs.

To order a unit less punch and die, add the suffix "- LPD".

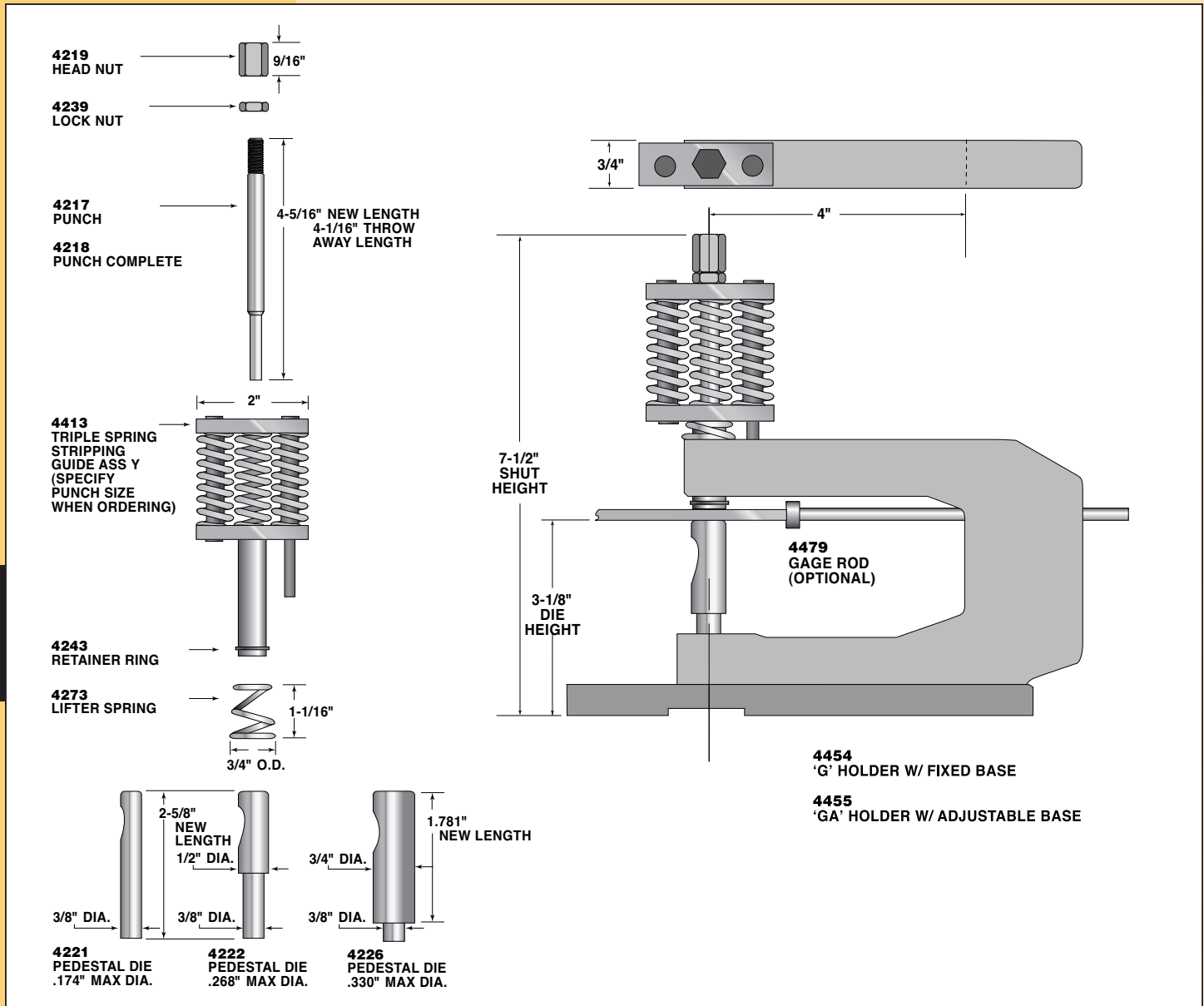

G SERIES

AE SERIES

For Channels
and Extrusions

SPECIFICATIONS & OPERATING INSTRUCTIONS

OPERATING SHUT HEIGHT:	10-3/8" (263.5mm)
MIN. SHUT HEIGHT:	10-1/4" (260.3mm)
UNIT OPEN HEIGHT:	11" (279.4mm)
DIE HEIGHT:	5-1/2" (139.7mm)
MIN. DIE CLEARANCE:	.006" (.15mm)

MAX. PUNCH DIAMETER:	.625" (15.87mm)
MIN. PUNCH DIAMETER:	.1875" (4.76mm)
MAX. SQUARE:	.441" (11.2mm)
MIN. SHAPE DIMENSION:	.0937" (2.38mm)
MAX. MAT. THK.:	4" (5.4#) CHANNEL (Based on 50,000 P.S.I. shear strength)

KITS AND SHIMS

Shaped hole conversion kit:	7134
Key kit:	9300
Hardware kit:	9343
Punch shim:	N.A.
Die shim:	1092- 12 pk. 1092- 48 pk. 1/16" thk./2 max.
Upper arm kit:	9737 Round 9738 Shaped

	COMPLETE ROUND UNITS	COMPLETE SHAPED UNITS	COMMON DIMENSIONS	
	Part No.	Part No.	Throat Depth	Shipping Weight
TAPERED DIE	2090	2095	1"	16 lbs.
FLAT DIE	2090F	2095F	1"	16 lbs.

To order a unit less punch and die, add the suffix "- LPD".

To order a shaped unit with round punch & die, add the suffix "- RPD".

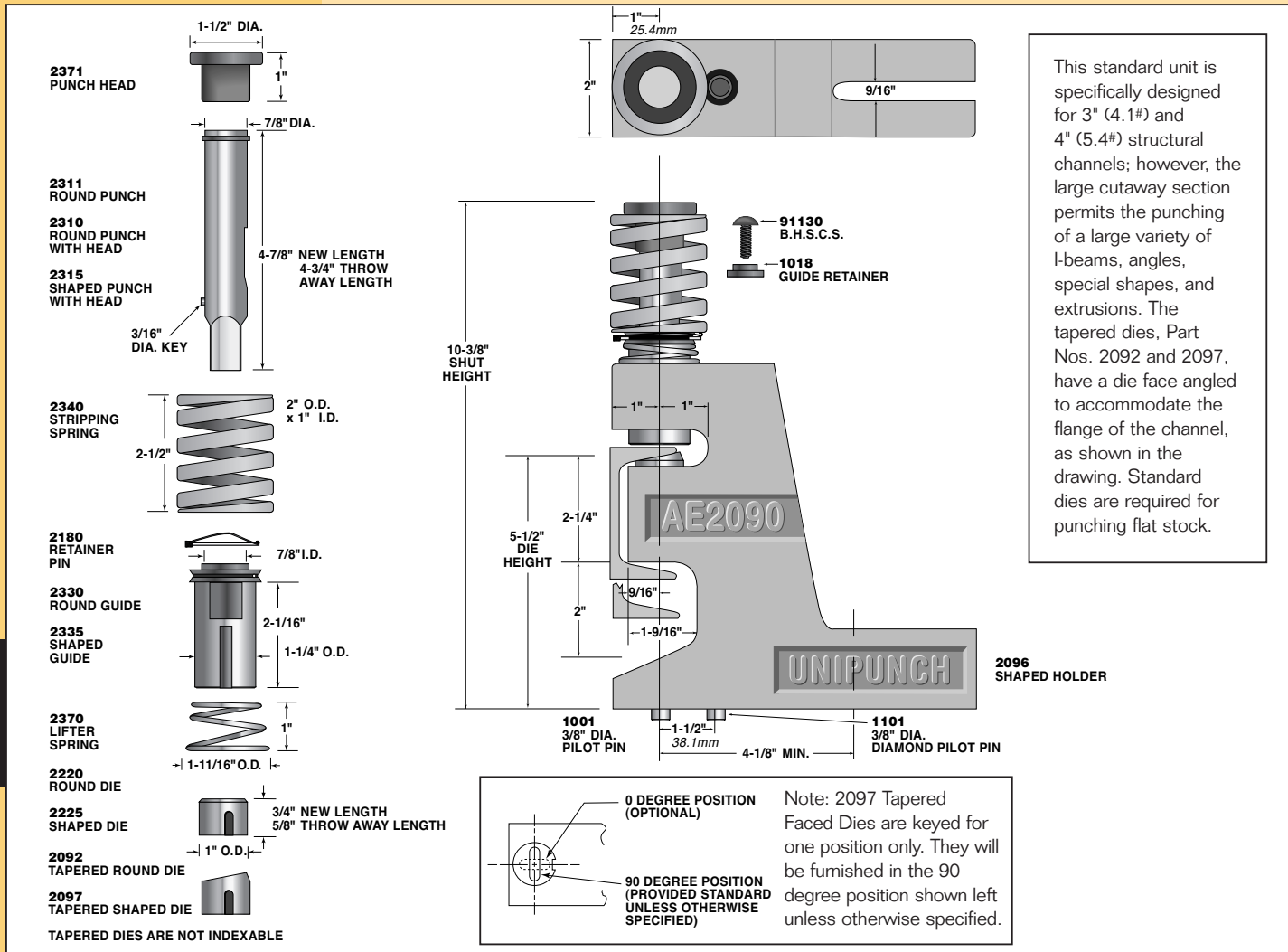

An infinite number of variations of holder shapes can be designed to accommodate irregular shapes and extrusions using standard "A" or "B" Series components in the special holders. Shown are examples of custom units.

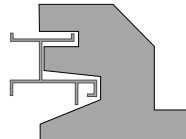

SEND
DRAWINGS
FOR PRICE
QUOTATION

TP (Tube & Pipe) Series Lineup

TP-1 1/4, TP-2-3/8, TP-2, TP-2M, TP-AE and TP-CN

- Punch round and shaped tubing
- Punch both sides of tube, or just one side
- Punch “dimpled” holes or deformation-free holes
- Cope or notch the end of tube or pipe

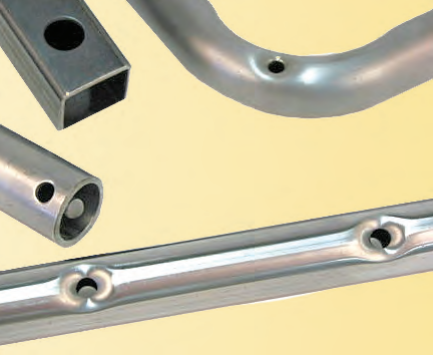

TP-1 1/4 Tube & Pipe Punching Unit (Page 74)

The TP-1 1/4 unit provides two sided punching in round or shaped tubes. The unit is designed for punching tube diameters from 9/16" O.D. to 1 1/4" O.D. Each assembly top and bottom contains a punch to pierce one hole in-line on each side of the tube. The tubing is supported on all sides during punching. If only one hole is desired, simply remove one of the punches. Depending on your material thickness, standard punch diameters are available from .0937" to .500". Non-standard tooling for larger hole sizes and/or shaped hole punching is also available.

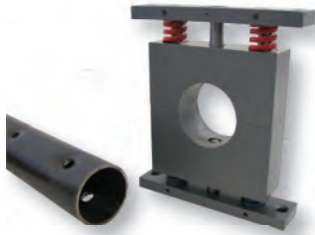

TP-2 3/8 Tube & Pipe Punching Unit (Page 75)

The TP-2 3/8 unit provides two sided punching in round or shaped tubes. The unit is designed for punching tube diameters from 1 5/16" O.D. to 2 3/8" O.D. Each assembly top and bottom contains a punch to pierce one hole in-line on each side of the tube. The tubing is supported on all sides during punching. If only one hole is desired, simply remove one of the punches. Depending on your material thickness, standard punch diameters are available from .0937" to .500" (12.7mm). Non-standard tooling for larger hole sizes and/or shaped hole punching is also available.



TP-2 Tube & Pipe Punching Unit (Page 76)

The TP-2 unit provides straight through holes with one punch in round or shaped tubing. The unit is designed for punching tube diameters from 9/16" O.D. to 1" O.D. The tubing is supported on all sides during punching. The top hole is dimpled; the bottom hole is punched into a die, providing a dimple free hole. (UniPunch offers custom mandrel style punching units for dimple free holes. See TP-2M.) Depending on your material thickness, punch diameters are available from .0937" to .4375". Non-standard tooling for shaped hole punching is also available.



TP-2M Unit Mandrel Tube Punching (Page 77 & 78)

The TP-2M mandrel style unit provides dimple-free holes in round, square or rectangular tube or pipe. The unit is designed for punching tube sizes up to 1", and each unit is designed for the particular hole size and tubing application. Depending on your material thickness, standard punch diameters are available up to .4375". Non-standard tooling for shaped hole punching is also available.



TP-AE Unit Mandrel Tube Punching (Page 77 & 79)

The TP-AE mandrel unit provides dimple-free holes near the end of round or shaped tube or pipe. Maximum hole size or shape depends on tube size and material wall thickness. The unit can also be used for notching or slitting the end of the tube.



TP-CN Units Tube & Pipe Coping & Notching (Page 80)

The TP-CN units provide tooling for tube and pipe coping and notching applications. Each unit is designed for the particular application. In addition, units are also available for tube and pipe slotting, vee notching, shearing, staking and trimming.

Note: For custom tube & pipe fabricating applications, contact the UniPunch Sales Department.

TP-1 1/4"

Dia./Square Max.

SPECIFICATIONS & OPERATING INSTRUCTIONS

MAX. SHUT HEIGHT:	6-1/4" (158.7mm)
MIN. SHUT HEIGHT:	6-1/8" (155.6mm)
MAX. TUBE SIZE:	1-1/4" O.D. (31.7mm) round or square
MIN. TUBE SIZE:	9/16" O.D. (14.3mm) round or square

MAX. WALL THICKNESS (MILD STEEL):	.125" (3.18mm)
MIN. WALL THICKNESS:	.031" (.79mm)
Note: For stainless steel tube punching applications contact UniPunch Sales Department	
MAX. HOLE DIAMETER:	.500" (12.7mm)

Note: For shaped holes, contact UniPunch Sales Department

TO ORDER, SPECIFY:

- Size of Tube
- Hole Diameter
- Wall Thickness
- Type of Material

Note: Because there is no die to support the tube at the site of the hole, tubes distort when punching. Distortion varies depending on punch size, tube O.D., wall thickness, and material type.

PUNCH SELECTION CHART		
Tube O.D.	Punch Length	Part No.
9/16" to 1 1/16"	3 1/32"	17210
3/4" to 7/8"	2 29/32"	17211
1 5/16" to 1 1/16"	2 13/16"	17212
1 1/8" to 1 1/4"	2 23/32"	17213

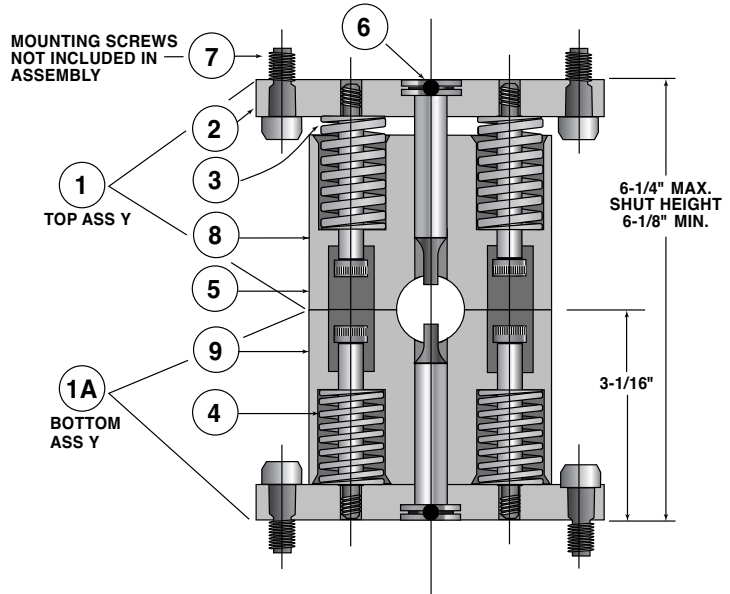
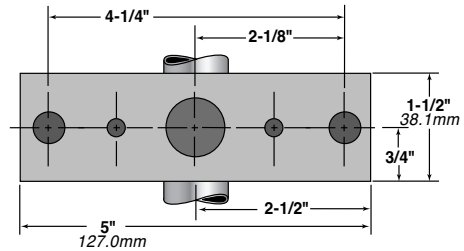

Item	Description	FOR ROUND TUBES UP TO 1.250" O. D.	FOR SQUARE TUBES UP TO 1.250" SQ.
		Part No.	Part No.
	Complete Unit (Includes Top & Bottom Punches)	17200	17300
1	Top Ass'y (Includes Punch)	17205	17305
1A	Bottom Ass'y (Includes Punch)	17206	17306
2	Punch Plate	17271	17271
3	Top Stripping Spring (Red) (2 Req'd)	17140	17140
4	Bottom Stripping Spring (Blue) (2 Req'd)	17160	17160
5	Stripper Bolt (2 Per Ass'y)	17138	17138
6	Roll Pin (1/8" Dia. x 3/16")	91679	91679
7	Mounting Screw (3/8"-16 x 1" S.H.C.S.)	91027	91027
8	Top Stripping Guide Only (Specify Tube O.D.)	17250	17350
9	Bottom Stripping Guide Only (Specify Tube O.D.)	17253	17353

SPEED WITHIN REACH

UNIPUNCH

SPECIFICATIONS & OPERATING INSTRUCTIONS

MAX. SHUT HEIGHT:	6-3/4" (171.4mm)
MIN. SHUT HEIGHT:	6-5/8" (168.3mm)
MAX. TUBE SIZE:	2-3/8" O.D. (60.3mm) round or square
MIN. TUBE SIZE:	1-5/16" O.D. (33.3mm) round or square

MAX. WALL THICKNESS (MILD STEEL):	.125" (3.18mm)
MIN. WALL THICKNESS:	.031" (.79mm)
Note: For stainless steel tube punching applications contact UniPunch Quotations Department	
MAX. HOLE DIAMETER:	.500" (12.7mm)

Note: For shaped holes, contact UniPunch Sales Department

TP-2³/₈"

Dia./Square Max.

PUNCH SELECTION CHART

Tube O.D.	Punch Length	Part No.
1 ⁵ / ₁₆ " to 1 ⁷ / ₁₆ "	3 ¹ / ₃₂ "	17210
1 ¹ / ₂ " to 1 ⁵ / ₈ "	2 ²⁹ / ₃₂ "	17211
1 ¹¹ / ₁₆ " to 2"	2 ¹³ / ₁₆ "	17212
2 ¹ / ₁₆ " to 2 ³ / ₁₆ "	2 ²³ / ₃₂ "	17213
2 ¹ / ₄ " to 2 ³ / ₈ "	2 ⁵ / ₈ "	17214

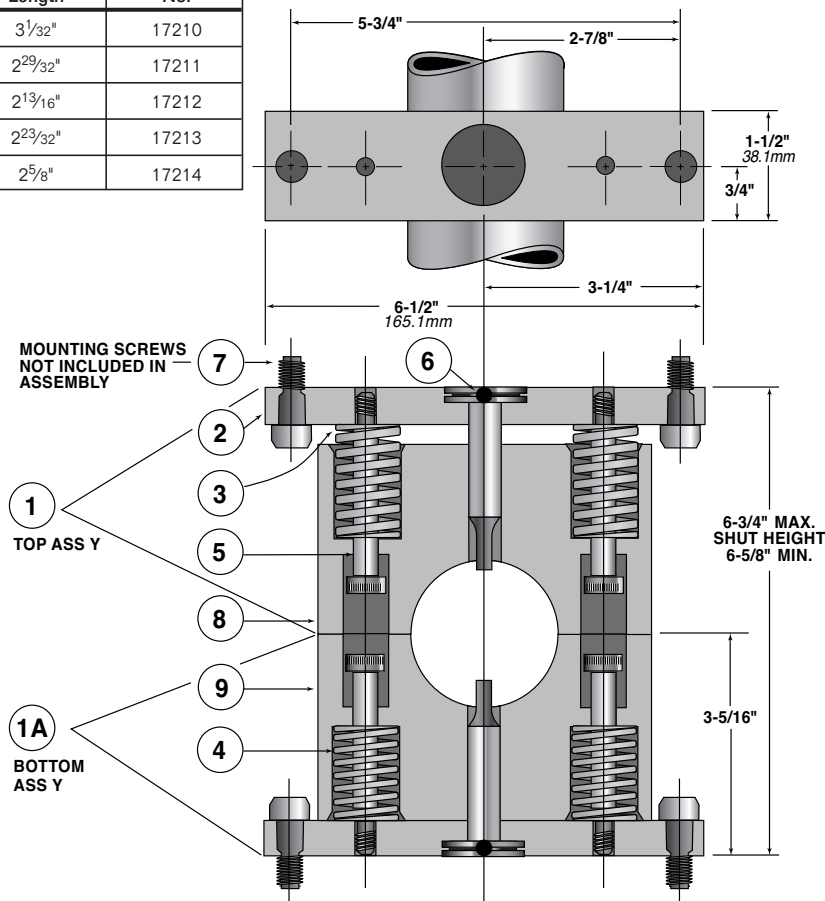

To ORDER, SPECIFY:

- Size of Tube
- Hole Diameter
- Wall Thickness
- Type of Material

Note: Because there is no die to support the tube at the site of the hole, tubes distort when punching. Distortion varies depending on punch size, tube O.D., wall thickness, and material type.

Item	Description	FOR ROUND TUBES UP TO 2.375" O. D.	FOR SQUARE TUBES UP TO 2.375" Sq.
		Part No.	Part No.
	Complete Unit (Includes Top & Bottom Punches)	17202	17302
1	Top Ass'y (Includes Punch)	17223	17323
1A	Bottom Ass'y (Includes Punch)	17224	17324
2	Punch Plate	17272	17272
3	Top Stripping Spring (Red) (2 Req'd)	17140	17140
4	Bottom Stripping Spring (Blue) (2 Req'd)	17160	17160
5	Stripper Bolt (2 Per Ass'y)	17139	17139
6	Roll Pin (1/8" Dia. x 3/16")	91679	91679
7	Mounting Screw (3/8"-16 x 1" S.H.C.S.)	91027	91027
8	Top Stripping Guide Only (Specify Tube O.D.)	17262	17362
9	Bottom Stripping Guide Only (Specify Tube O. D.)	17263	17363

TP SERIES

TP-2"

1" (25.4mm) round max.
7/8" (22.2mm) square max.

SPECIFICATIONS & OPERATING INSTRUCTIONS

OPERATING SHUT HEIGHT:	9-3/8" (238.1mm)
MIN. SHUT HEIGHT:	9-1/4" (235.0mm)
UNIT OPEN HEIGHT:	11-13/16" (300.0mm)
MAX. TUBE SIZE:	1.000" round (25.40mm) 7/8" square (22.2mm)
MIN. TUBE SIZE:	9/16" (14.3mm) round or square

MAX. WALL THICKNESS (MILD STEEL):	.125" (3.18mm)
MIN. WALL THICKNESS:	.031" (.79mm)
Note: For stainless steel tube punching applications contact UniPunch Quotations Department	
MIN. DIE CLEARANCE:	.012" (.30mm)
MAX. PUNCH DIAMETER:	.4375" (11.1mm)

TO ORDER, SPECIFY:

- Size of Tube
- Hole Diameter
- Wall Thickness
- Type of Material

Note: Because there is no die to support the tube at the site of the hole, tubes distort when punching. Distortion varies depending on punch size, tube O.D., wall thickness, and material type.

KITS AND SHIMS

Key kit: 9414

To produce shaped holes in the model TP-2 unit (eg. obround, square) contact the UniPunch Sales Department.

Note: Bottom hole in tube will not be distorted due to die support.

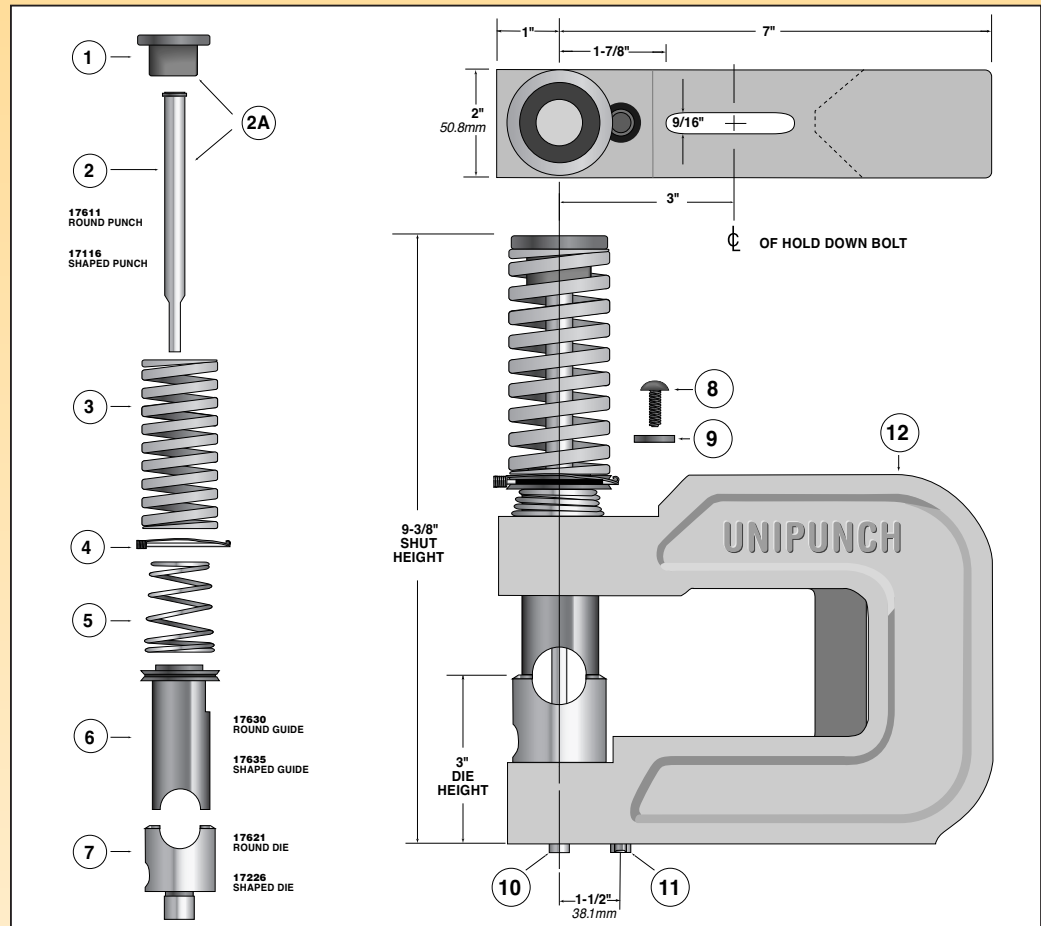

Item	Description	FOR ROUND TUBES UP TO 1.000" O. D.	FOR SQUARE TUBES UP TO .875" Sq.
		Part No.	Part No.
	Complete Unit (Includes Punch & Die)	17600	17700
1	Punch Head	17671	17671
2	Round Punch	17611	17611
2A	Round Punch with Head	17610	17610
3	Stripping Spring	17640	17640
4	Punch Retainer Pin	2180L	2180
5	Lifter Spring	17670	17670
6	Guide (Specify Tube O.D.)	17630	17730
7	Die (Specify Tube O.D.)	17621	17721
8	B.H.S.C.S.	91130	91130
9	Guide Retainer	1018	1018
10	Pilot Pin (Round)	1120	1120
11	Pilot Pin (Diamond)	1101	1101
12	Holder	17650	17650

SPEED WITHIN REACH

UNIPUNCH



Dimple-free Holes

Aluminum - Steel - Copper or Brass

Mandrel Tube Punching



TP-2M

This mandrel tube punching unit will pierce holes 180° apart with each press stroke.

UniPunch provides custom mandrel style hole punching units for dimple-free holes in tube or pipe. Mandrel punching units are offered for producing round or shaped holes in single or multiple hole configurations in round, square or rectangle tubing or pipe. Due to the style variations, shut heights and die heights are determined by individual mandrel unit designs.

The photos below are examples of additional UniPunch designs that use mandrels in the tube for dimple free hole. For a prompt quotation, please send us a detailed drawing or sketch including tube or pipe size, hole size and hole location.

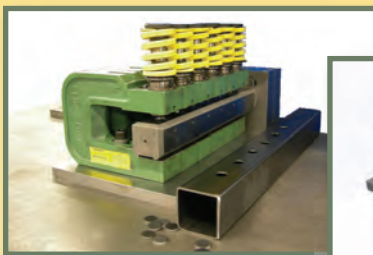

C-Frame Design

The tube mandrel is mounted into a steel block for single or multiple hole patterns. Standard UniPunch C-Frame units are used for producing round or shaped holes.



AE Design

These mandrel units are designed for producing holes near the ends of tube or pipe. Interchangeable mandrels are available for different tube or hole sizes.



TP-2 Long Mandrel

The 8" throat unit allows holes to be pierced at a greater distance from the tube end.



HZ Design

This mandrel system will produce dimple-free holes 180° apart with each press stroke. UniPunch horizontal units are used for producing round or shaped holes.

TP SERIES

SPEED WITHIN REACH

UNIPUNCH

TP-2M

SPECIFICATIONS & OPERATING INSTRUCTIONS

OPERATING SHUT HEIGHT:	9-3/8" (238.1mm)
MIN. SHUT HEIGHT:	9-1/4" (235.0mm)
UNIT OPEN HEIGHT:	11-13/16" (300.0mm)
MAX. TUBE SIZE:	1.000" round (25.40mm) 7/8" square (22.2mm)

MAX. WALL THICKNESS (MILD STEEL):	.125" (3.18mm)
MIN. DIE CLEARANCE:	.012" (.30mm)

TO ORDER, SPECIFY:

- Size of Tube
- Hole Diameter
- Wall Thickness
- Type of Material
- Hole Location

COMPLETE UNIT	COMMON DIMENSIONS	
Part No.	Throat Depth	Shipping Weight
17600M	8"	20 lbs.

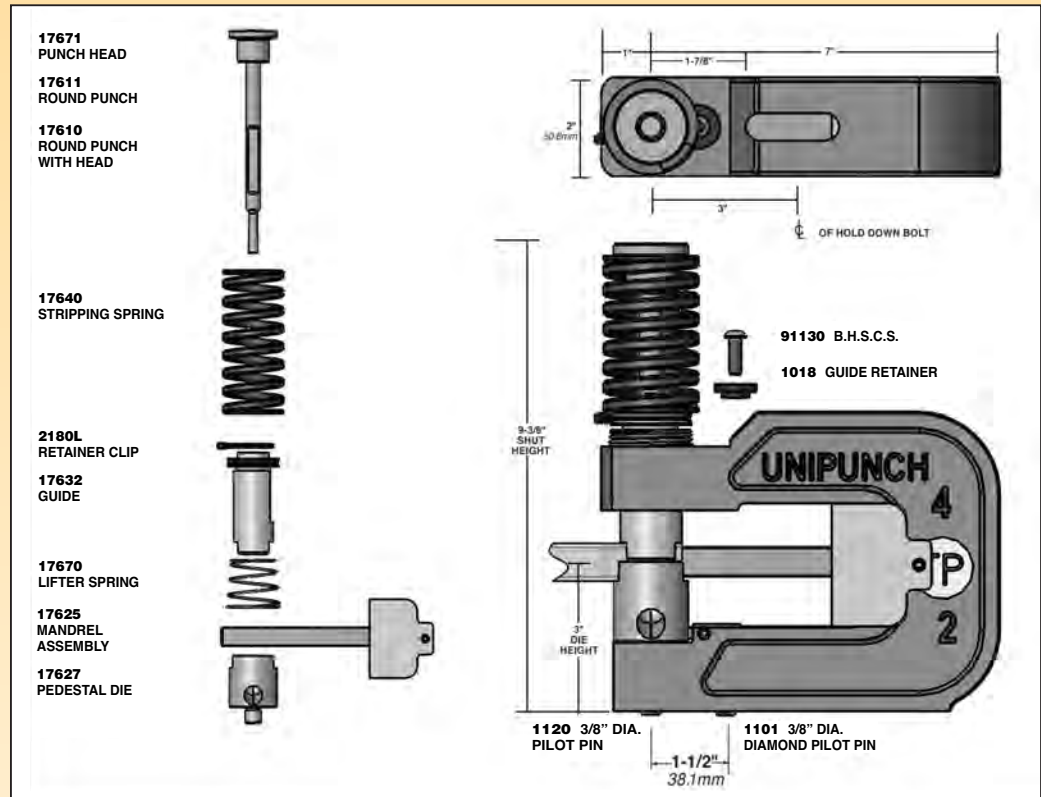

Note: Various throat depths are available. Contact the UniPunch Sales Department with tube specifications and hole location.

TP SERIES

SPECIFICATIONS & OPERATING INSTRUCTIONS

OPERATING SHUT HEIGHT:	10-3/8" (263.5mm)
MIN. SHUT HEIGHT:	10-1/4" 260.3mm)
UNIT OPEN HEIGHT:	11" (279.4mm)
DIE HEIGHT:	5-1/2" (139.7mm)
MIN. DIE CLEARANCE:	.006" (.15mm)

TP-AE

COMPLETE ROUND UNITS	COMPLETE SHAPED UNITS	COMMON DIMENSIONS	
Part No.	Part No.	Throat Depth	Shipping Weight
2090M	2095M	1"	14 lbs.

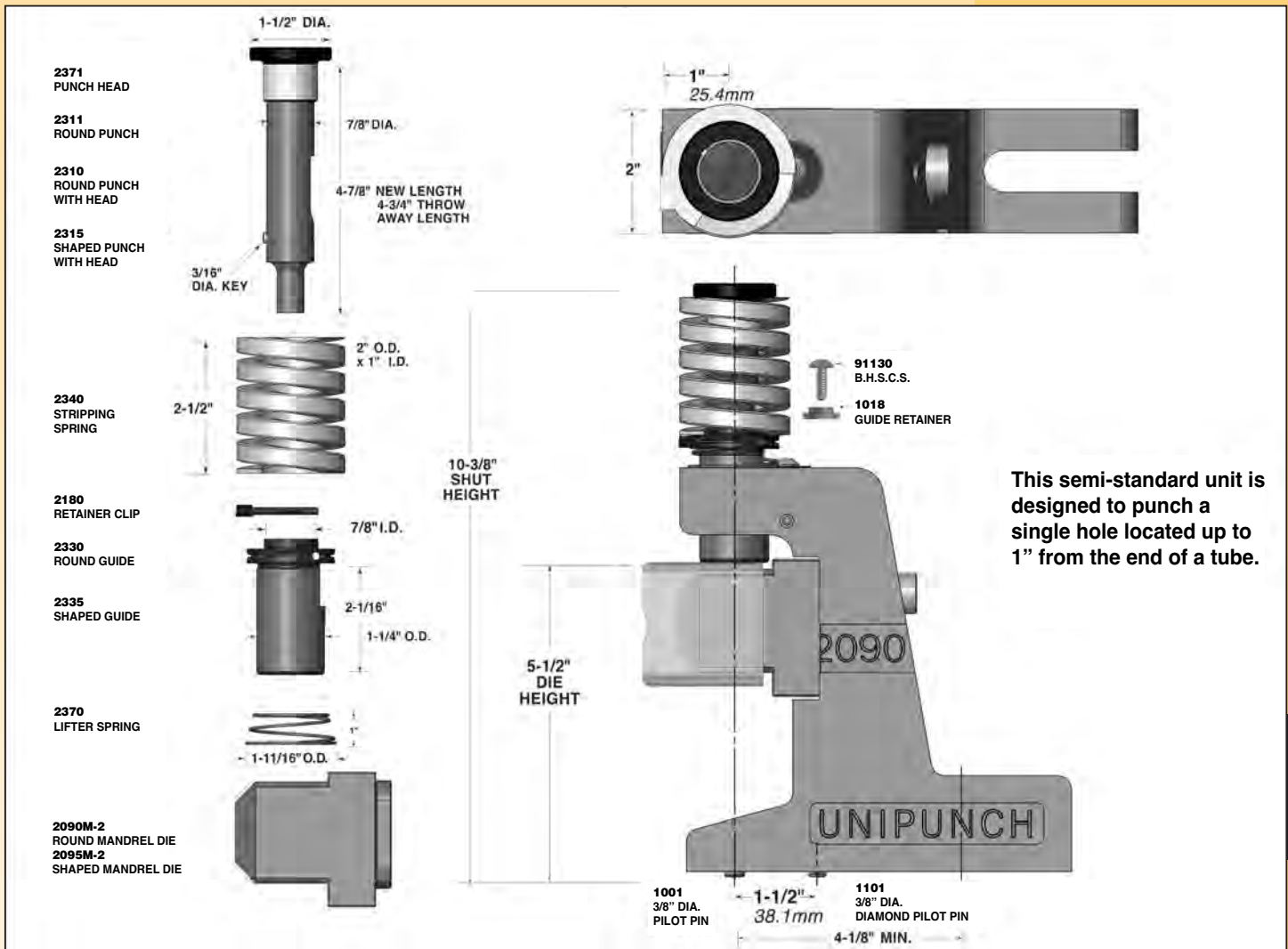

This semi-standard unit is designed to punch a single hole located up to 1" from the end of a tube.

Note: Mandrel dies are custom made to your tube specifications. Please provide drawing showing the hole size and location on the tube.

TP SERIES

TP-CN Series



Tube & Pipe Coping Tooling

Custom designed and built to your requirements

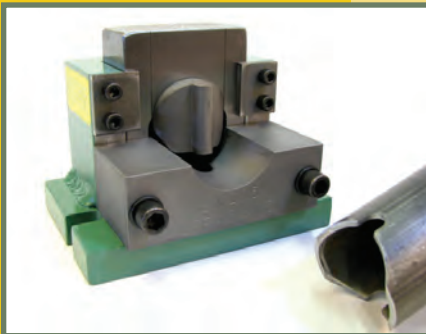
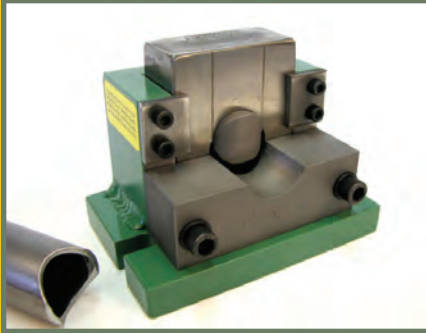

- UniPunch TP-CN Series end coping and notching units for 90 degree T-joints and custom angle configurations such as used in pre-welding applications for manufacturing of furniture, gates & fences, railings, food processing and marine products.
- Tube side-wall V-notching tools, tube flattening and end trimming tools are also available.
- Tube & pipe coping tooling operate as stand-alone units that can be mounted into numerous presses, iron workers and air over oil or hydraulic punching systems.

Begin by sending us a drawing of your notch configuration, tube or pipe size and wall thickness. UniPunch will provide engineering assistance and promptly quote tooling for your part. In addition to pipe notching, other common applications include:

- Slotting
- Edge Notching
- V-Notching
- Shearing
- Staking
- Trimming
- Flattening

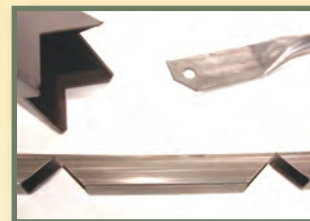
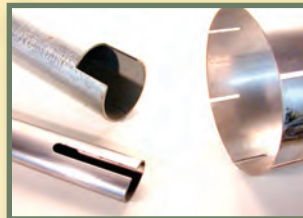

Note: Due to the style variations, shut heights and die heights are determined by individual coping and notching unit designs.

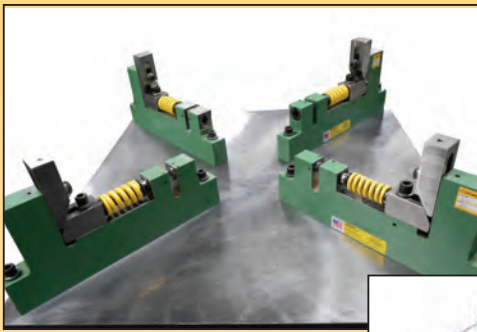

HZ Series Lineup

The "HZ" units are designed for horizontal punching of holes in the vertical sides of flanges, rims and formed parts. In operation, the press ram depresses the vertical plunger forcing the punch horizontally through the material. On the upstroke of the ram, the stripping spring removes the punch from the work piece.

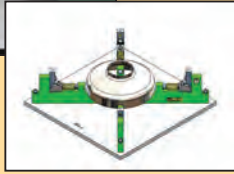

- Four available models: 3/4", 1 1/4", 1 1/2" and 2"
- HZ-3/4 holder provides closest center-to-center holes
- Material Thickness: Up to 1/4" mild steel
(HZ-3/4 maximum material capacity is 3/32" mild steel)

SPECIFICATIONS & OPERATING INSTRUCTIONS

OPERATING SHUT HT.:	4-3/8" (111.1mm)	MIN. DIE CLEARANCE:	.006" (.15mm)
MIN. SHUT HEIGHT:	4-1/4" (107.9mm)	MAX. PUNCH DIAMETER:*	.2500" (6.35mm)
UNIT OPEN HEIGHT:	4-7/8" (123.8mm)	MIN. PUNCH DIAMETER:	.0937" (2.38mm)
MATERIAL FEED CLEARANCE:	1/8" (3.2mm)	MAX. MATERIAL THICKNESS (STAINLESS STEEL):	1/16" (1.6mm)
MAX. MATERIAL THICKNESS (MILD STEEL):	3/32" (2.4mm)		

*For punch sizes greater than .2500" contact the UniPunch sales department.

COMPLETE ROUND UNITS

Model No.	Part No.	Shipping Weight
HZ-3/4	10500	3.5 lbs.

To order a unit less punch and die, add the suffix "- LPD".

HZ-3/4 Unit for Round Holes Only

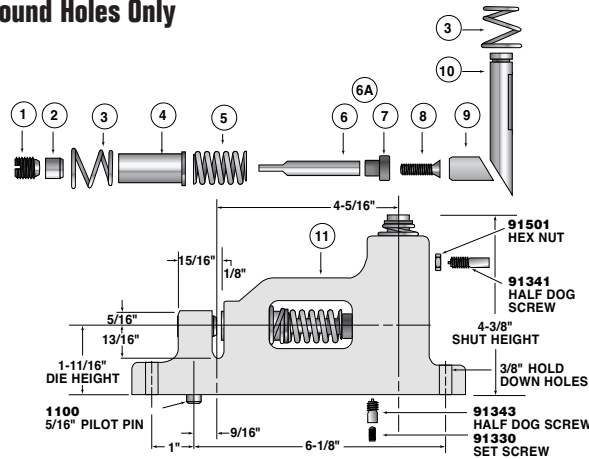

Item No.	Description	Part No.
1	Adjustment Screw	10522
2	Round Die	10520
3	Lifter Spring	4273
4	Guide (Round)	10530
5	Stripping Spring	3640
6	Punch Only	3211
6A	Punch w/ Head	10510
7	Punch Head	10571

Item No.	Description	Part No.
8	Punch Screw FHSCS	91205
9	Wedge	10573
10	Plunger	10572
11	Holder	10550
KITS & SHIMS	Hardware Kit:	9380
	Punch Shim:	N.A.
	Die Shim:	N.A.

HZ-3/4"

19mm width

Series HZ - Horizontal Hole Punching Units

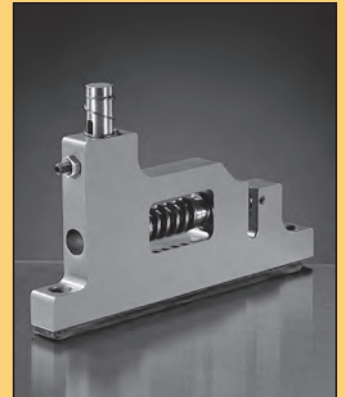

HZ SERIES

See next page for additional horizontal hole punching units and specifications.

SPEED WITHIN REACH
UNIPUNCH

HZ

1-1/4" (31.8mm)
1-1/2" (38mm)
2" (50.8mm)

SPECIFICATIONS & OPERATING INSTRUCTIONS

OPERATING SHUT HEIGHT:	7-1/2" (190.5mm)
MIN. SHUT HEIGHT:	7-1/16" (179.4mm)
UNIT OPEN HEIGHT:	8-1/2" (215.9mm)
MATERIAL FEED CLEARANCE:	3/8" (9.5mm)

MIN. DIE CLEARANCE:	.006" (.15mm)
MAX. MATERIAL THICKNESS (MILD STEEL):	1/4" (6.4mm)
MAX. MATERIAL THICKNESS (STAINLESS STEEL):	3/32" (2.4mm)

COMPLETE ROUND UNITS

Model No.	Part No.	Max. Punch Dia.	Min. Punch Dia.
HZ-1/4	10000	.4375 11.11 mm	.0937 2.38 mm
HZ-1/2	10100	.6250 15.87 mm	.1250 3.18 mm
HZ-2	10200	.8750 22.22 mm	.1875 4.76 mm

To order a unit less punch and die, add the suffix "- LPD".

COMPLETE SHAPED UNITS

Model No.	Part No.	Max. Square	Min. Shaped Dim.
SHZ-1/4	10005	.309 7.85 mm	.0937 2.38 mm
SHZ-1/2	10105	.441 11.20 mm	.0937 2.38 mm
SHZ-2	10205	.618 15.69 mm	.1250 3.17 mm

To order a shaped unit with round punch & die, add the suffix "- RPD".

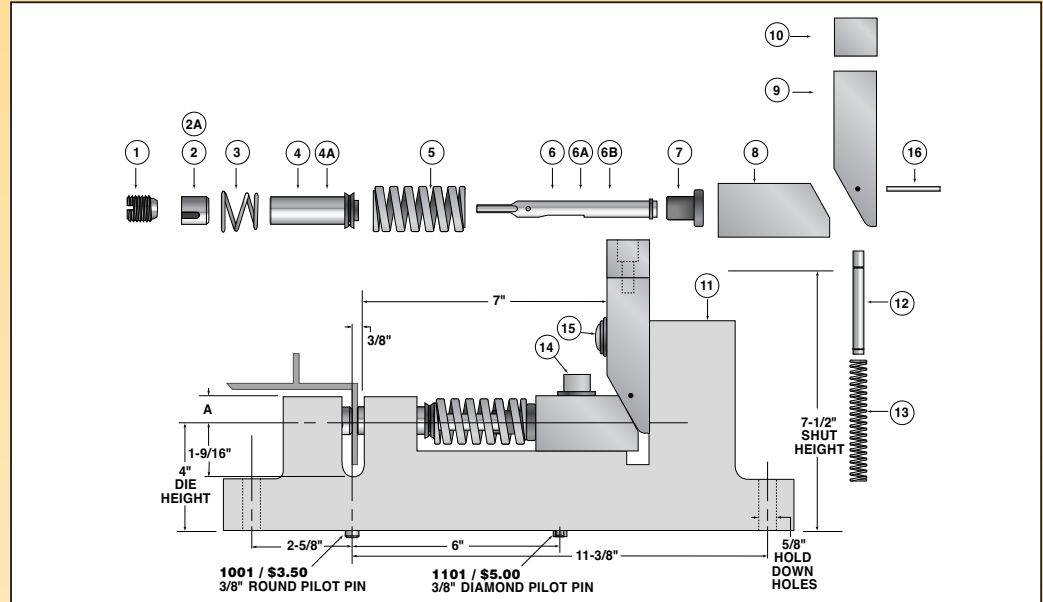

COMMON DIMENSIONS

Holder Width	A	Shipping Weight
1/4"	9/16"	22.5 lbs.
1/2"	1 1/16"	28 lbs.
2"	7/8"	40 lbs.

		HZ-1/4"	HZ-1/2"	HZ-2"
Item No.	Description	Part No.	Part No.	Part No.
1	Adjustment Screw	10022	10122	10222
2	Round Die	2120	2220	2320-2
2A	Shaped Die	2125	2225	2325-2
3	Lifter Spring	2170	2270	2370
4	Round Guide	2130	2230	2330
4A	Shaped Guide	2135	2235	2335
5	Stripping Spring	2140	2240	2340
6	Round Punch	2111	2211	2311
6A	Round Punch with Head	2110	2210	2310
6B	Shaped Punch with Head	2115	2215	2315
7	Punch Head	2171	2271	2371
8	Wedge	10073	10173	10273
9	Plunger	10072	10172	10172
10	Adapter (to adjust height to 8-3/8")	10074	10074	10074
11	Holder	10055	10155	10255
12	Guide Pin	10041	10041	10041
13	Plunger Spring	10070	10070	10070
14	S.H.C.S.	91057	91057	91059
15	B.H.S.C.S.	91153	91153	91153
16	Roll Pin	91676	91677	91677
KITS	Shaped Hole Conversion Kit	7145	7146	7147
	Key Kit:	9320	9320	9321
&	Hardware Kit:	9381	9382	9383
	Punch Shim:	N.A.	N.A.	N.A.
SHIMS	Die Shim:	N.A.	N.A.	N.A.

HZ SERIES

SPEED WITHIN REACH

UNIPUNCH

Fitted Strippers

Fitted End Stripping Guide Options

Use fitted strippers for applications requiring minimum sheet distortion in light gauge material and/or applications with multiple holes or irregular shapes.

A SERIES FITTED END STRIPPING GUIDES

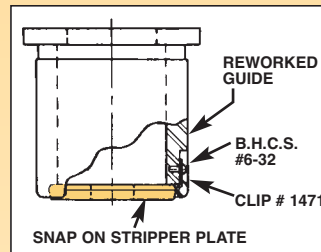
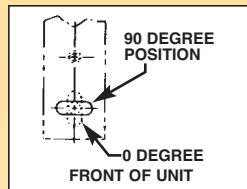
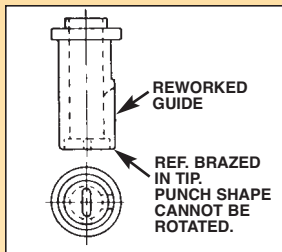

Unit		Guide Part No.
A-1, A-1¼	Round	2131
AJ-1, AJ-1¼	Shaped	2138
A-1½	Round	2231
AJ-1½	Shaped	2238
A-2	Round	2331
AJ-2	Shaped	2338



Unit		Guide Part No.	Stripper Plate Part No.
A-2½	Round	2465	2487
AJ-2½	Shaped		2488
A-3½	Round	2975	9548
	Shaped		9558
A-5½	Round	2885	2882
	Shaped		2883
A-8	Round	1485	1482
	Shaped		1483

Note: Shapes will be supplied as shown in 90 degree position unless ordered otherwise.

B SERIES FITTED END STRIPPING GUIDES

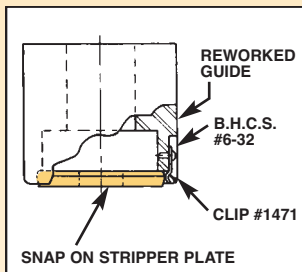

Unit		Guide Part No.	Stripper Button
BX-¾	Round only	3035	N/A
B-1	Round only	3234	N/A
B-1¼	Round	3323	3332
	Shaped	3324	3339F
B-1¾	Round	3423	3432
	Shaped	3427	3439F
BX-2¼	Round	3523	3532
	Shaped	3524	3539F

Unit		Guide Part No.	Stripper Plate
B3	Round	3665	3683
	Shaped		3682
B-5	Round	Use standard 3681 guide	3883
	Shaped		3882



Optional Inexpensive Nylon Strippers For B Series Units

These low-cost nylon strippers are furnished blank and press fit into bottom of stripping guide as shown. At first hit of the press, the punch pierces the blank stripper exactly to size. **They are great for punching prepainted material without marking.** Punch tips must be at least 1/16" (1.6mm) under the punch body size to use strippers.

For Unit	Part No.
B-1¼	3377
B-1¾	3477
BX-2¼	3577

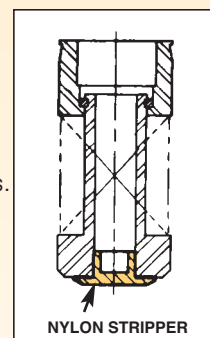

ADDL. PRODUCT

Shims & Tonnage Reduction

Shims Extend Life of Punches and Dies Up To 4 Times

Why throw away your punches and dies after a few sharpenings? 1/16" (1.6mm) thick shims are available to restore them to original length. "B" Series punches and dies are shimmed as shown in drawings.

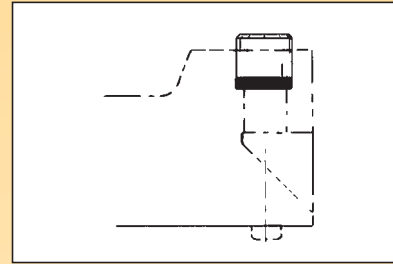
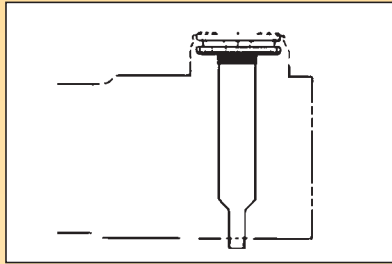

PUNCH SHIMS	
Part No.	Unit
1080	B-1, B-1 1/4
1081	B-1 3/4
1082	BX-2 1/4
1089	BX 3/4
1098	B-3x3 Notch Unit
1103	A & B-5x5 Notch Unit
1109	A-2 1/2, A-3 1/2, A-5 1/2, AH 3 1/2, AHD-3 1/2 AH-6, OA-6 (2 1/4" dia. & under)
1112	B-3
1113	B-5
1114	AH-2 1/2
3709	AH-3, AHD-3
1197	AH-6, OA-6, (over 2 1/4" dia. & all shapes)

DIE SHIMS	
Part No.	Unit
1091	A-1, A-1 1/4, B-1 1/4, B-1 3/4
1092	A-1 1/2
1093	A2
1094	A-2 1/2, AH-2 1/2, AHD-2 1/2,
1095	A-3 1/2, AH-3 1/2, AHD-3 1/2
1096	B-3
1117	AJ-1, AJ-1 1/4 (Pedestal /Adapter)
1118	AJ-1 1/2 (Pedestal /Adapter)
1119	AJ-2, AJD-2 (Pedestal /Adapter)
1128	A-5 1/2, AH-6, B-5
1194	BX-2 1/4

Compensator Caps for "A" and "AJ" Units (1, 1 1/4, 1 1/2, 2)

For gang punching with "A" or "AJ" Series Units, Compensator Caps are fastened to the punch heads to reduce the total punching force. These caps stagger the punch length so the punches contact the work piece at different intervals, thus reducing the total tonnage required.

A and AJ Unit Widths	A	B	Part Number
1 and-1 1/4	1 1/2	1 1/32	1040
1 1/2	1 3/4	1 9/32	1041
2	2	1 17/32	1042

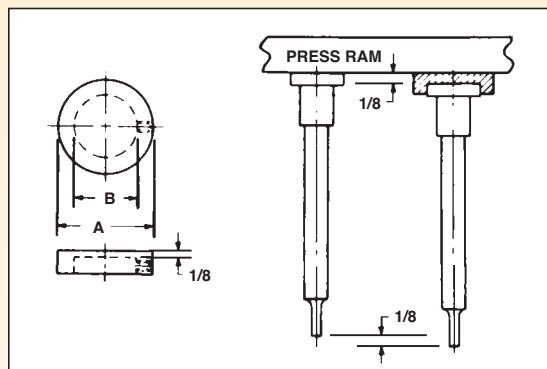

ADDL. PRODUCT

SPEED WITHIN REACH

UNIPUNCH

UniPunch now offers upper arm components as single kits for the many “A”, “AJ” and “B” Series holders. You can avoid costly down time by having these kits readily available for immediate installation when required.

Upper Arm Kits - “A”, “AJ” Series

A-1 / AJ-1 ROUND	A-1 / AJ-1 SHAPED
KIT NO. 9731	KIT NO. 9732
2045 Stripper Spring	2045 Stripper Spring
2180 Retainer Clip	2180 Retainer Clip
2030 Round Guide	2035 Shaped Guide
2070 Lifter Spring	2070 Lifter Spring

A-1 1/4 / AJ-1 1/4 ROUND	A-1 1/4 / AJ-1 1/4 SHAPED
KIT NO. 9733	KIT NO. 9734
2140 Stripper Spring	2140 Stripper Spring
2180 Retainer Clip	2180 Retainer Clip
2130 Round Guide	2135 Shaped Guide
2170 Lifter Spring	2170 Lifter Spring

A-1 1/2 / AJ-1 1/2 ROUND	A-1 1/2 / AJ-1 1/2 SHAPED
KIT NO. 9735	KIT NO. 9736
2240 Stripper Spring	2240 Stripper Spring
2180 Retainer Clip	2180 Retainer Clip
2230 Round Guide	2235 Shaped Guide
2270 Lifter Spring	2270 Lifter Spring

A-2 / AJ-2 ROUND	A-2 / AJ-2 SHAPED
KIT NO. 9737	KIT NO. 9738
2340 Stripper Spring	2340 Stripper Spring
2180 Retainer Clip	2180 Retainer Clip
2330 Round Guide	2335 Shaped Guide
2370 Lifter Spring	2370 Lifter Spring

A-2 1/2 / AJ-2 1/2 ROUND	A-2 1/2 / AJ-2 1/2 SHAPED
KIT NO. 9739	KIT NO. 9740
2485 Punch Screw	2485 Punch Screw
2440-10 Stripper Spring	2440-10 Stripper Spring
2433 Retainer Ring	2433 Retainer Ring
2435 Round Guide	2435 Shaped Guide
2470 Lifter Spring	2470 Lifter Spring

Upper Arm Kits - “B” Series

BX-3/4 ROUND
KIT NO. 9761
3033 Stripper Bolt (2)
3032 Retainer Plate
3040 Stripper Spring
3030 Round Guide
4273 Lifter Spring

B-1 1/4 ROUND	B-1 1/4 SHAPED
KIT NO. 9763	KIT NO. 9764
3372 Punch Retainer	3372 Punch Retainer
3370 Lifter Spring	3370 Lifter Spring
3330 Round Guide	3335 Round Guide

B-1 3/4 ROUND	B-1 3/4 SHAPED
KIT NO. 9765	KIT NO. 9766
3472 Punch Retainer	3472 Punch Retainer
2370 Lifter Spring	2370 Lifter Spring
3430 Round Guide	3435 Shaped Guide

BX-2 1/4 ROUND	BX-2 1/4 SHAPED
KIT NO. 9767	KIT NO. 9768
3572 Punch Retainer	3572 Punch Retainer
3570 Lifter Spring	3570 Lifter Spring
3530 Round Guide	3536 Shaped Guide

“A” & “AJ” SERIES



Kit No. 9736 shown

“B” SERIES



Kit No. 9768 shown

ADDITIONAL PRODUCT

Stock Punch Sizes

For "A", "AJ", "FTA", "HZ", and "AE" Units

- Available for immediate shipment
- Round punch sizes from 3/32" to 7/8"



2111 Round Punch 2010 Round Punch w/head 2011 Round Punch w/head

Fractional Inch	Decimal Inch	Metric (mm)
1/8	.1250	3.175
5/32	.1562	3.969
3/16	.1875	4.762
-	.1960	4.978
13/64	.2031	5.159
7/32	.2187	5.556
1/4	.2500	6.350
-	.2570	6.527
-	.2600	6.604
17/64	.2656	6.747
9/32	.2812	7.144
5/16	.3125	7.938
11/32	.3437	8.731
3/8	.3750	9.525
25/64	.3906	9.525
13/32	.4062	10.319
7/16	.4375	11.112

2211 Punch 2210 Punch w/head

Fractional Inch	Decimal Inch	Metric (mm)
11/64	.1718	4.366
3/16	.1875	4.762
13/64	.2031	5.159
7/32	.2187	5.556
1/4	.2500	6.350
-	.2570	6.527
17/64	.2656	6.747
-	.2700	6.858
9/32	.2812	7.144
5/16	.3125	7.938
11/32	.3437	8.731
3/8	.3750	9.525
25/64	.3906	9.525
13/32	.4062	10.319
7/16	.4375	11.112
1/2	.5000	12.700
17/32	.5312	13.494
9/16	.5625	14.288
5/8	.6250	15.875

2311 Punch 2310 Punch w/head

Fractional Inch	Decimal Inch	Metric (mm)
5/16	.3125	7.938
3/8	.3750	9.525
13/32	.4062	10.319
7/16	.4375	11.112
1/2	.5000	12.700
17/32	.5312	13.494
9/16	.5625	14.288
5/8	.6250	15.875
11/16	.6875	14.462
3/4	.7500	19.050
13/16	.8125	20.638

UniPunch provides immediate shipment on common punch diameters.



ADDL. PRODUCT

SPEED WITHIN REACH

UNIPUNCH

Custom Units

Designed and manufactured for applications in...

- Angles - Channels - Aluminum Extrusion
- Roll Formed or Brake Formed Parts
- Irregular Shaped or Molded Parts

In cases where standard UniPunch modular units cannot produce the necessary results for your specific application, our experience in die design and the manufacture of custom units can provide successful solutions for your punching or notching requirements. Examples would be holes close to the leg of an angle, channel or an aluminum extrusion or irregular notching and punching configurations.

Begin by sending us your detailed part drawing or sample part. For holes in specific locations in aluminum extrusions, a profile drawing is required. Our engineering team will review your part application and promptly quote tooling to meet your needs. The photos below are examples showing custom units that UniPunch can provide.



Tandem Units

Ordinarily the holder width defines the minimum hole centers. Shown here are custom tandem units designed for specific applications that use standard upper arm components to punch multiple rows of holes in a single stroke.

Block Die Units

For applications where holes are required near the legs of angles or extrusions, UniPunch can provide block style dies in "A" or "AH"- Series units. Upon request, the block die can also provide the required front to back part gauging.

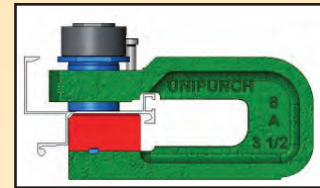

Standard "A"- Series UniPunch unit modified to accept block die for punching aluminum extrusions.

Custom Notching Units

For part notching applications in unique custom extrusions, UniPunch can design and build tooling for your application. Custom corner notch, edge notch or combination notch and punch units are available.



UniPunch Gib Style notching units

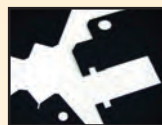

Custom corner notching

Custom Die Sets

For applications that include holes, notches or other features outside the capabilities of standard UniPunch units, UniPunch will build compatible custom die sets with the shut height and die height to work alongside the standard "A" or "B" Series units used in the application.

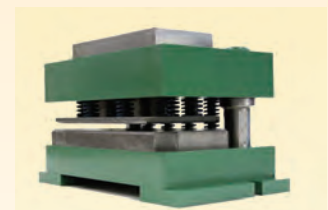
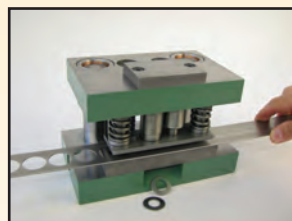

Description	Part No.
Sharpener Complete with Grinding Wheel	1125
Grinding Wheel	1145
Diamond Wheel Dresser	1135
Spray Mist Attachment	1129
Punch & Die Gauge – A series	2068
Punch & Die Gauge – B series	3068
Safety Shield	1179

Punch & Die Sharpener

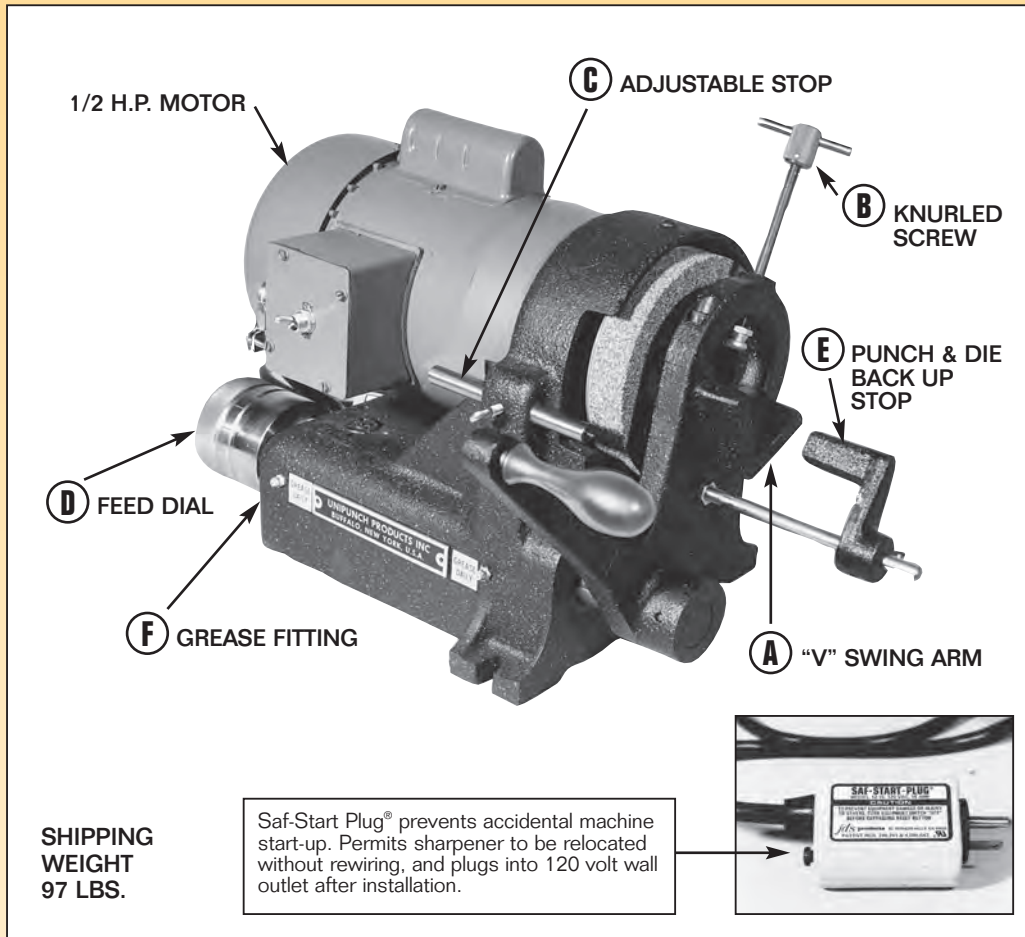

Grinding Wheel/Diamond Dresser



Spray Mist Attachment



Safety Shield

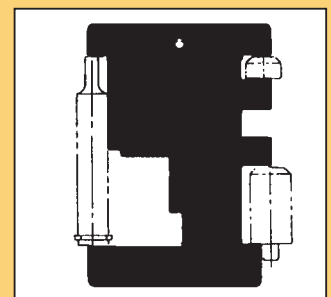

Punch & Die Gauges

The Punch and Die Sharpener is a bench type grinder. Simplicity of design and operation allows quick and easy sharpening of flat face punches and dies up to **2-5/8" (66.68 mm)** diameter maximum.

For best results, the sharpener should be bolted to a level work table with the Swing Arm Punch and Die Holder Handle extending beyond the edge of the table. The sharpener has a 1/2 H.P., 3450-RPM 115/208/230-volt 60 cycle motor. The punch or die is positioned in the Swing Arm (A) and fastened securely in position with the Knurled Head Screw (B). The Adjustable Stop (C) is used for positioning of the punches and dies in relation to the grinding surface of the wheel. The Spring-loaded Ball Stop prevents binding as the punch or die passes the gauge point. Laying the straight edge across the face of wheel sets the location of the adjustable stop in relation to the face of grinding wheel. The stop is adjusted out to the wheel.

Holding the Swing Arm Handle in your right hand, swing up past the wheel while turning the knurled feed dial (D) with your left hand for precision control of feed. Each mark on the dial indicates .005" (.13 mm) feed. Adjust the Back-up Stop (E) along the stop mounting bar to back up punches and dies. This Back-up Stop is also used to insure that punches and dies are ground to the same heights. The optional Spray Mist Attachment (Part No.1129) is available for mist cooling and lubricating punches and dies, and is equipped with a one-gallon tank, one nozzle, bracket, five-foot double tubing and operates from an air line pressure of 6 psi and up. The air inlet is 1/4" NPS(M). The grinding tolerance is 1" (25.4mm) diameter rod ground to 90 degrees within .003" (.08mm).

Grease Fittings (F) are provided for periodic lubrication of the Swing Arm. The totally enclosed self-lubricating motor will give years of trouble-free service. The sharpener should be regularly cleaned of grinding dust.

To dress the grinding wheel, the Diamond Wheel Dresser (Part No. 1135) is secured in the 'V' of the Swing Arm and adjusted to the face of the wheel by means of the Knurled Feed Dial (D). Swing the Diamond Wheel Dresser across the wheel at a steady, slow speed removing a few thousandths on each pass until properly dressed.

Refer to tool maintenance page 90 for additional sharpening information.

ADD'L. PRODUCT

PROPER SET UP PRACTICE (MOUNTING INFORMATION)

- Remove all dirt from unit bottoms and mounting surfaces to insure that units are flat on the mounting templates.
- Use proper length bolts and washers when securing units to mounting templates.
- Check unit die heights. All holders must have uniform die heights to prevent sheet distortion and unit misalignment.
- Before starting press, be sure set-up is guarded in compliance with regulations.
- After positioning the setup in the press, adjust shut height by gradually lowering the press ram until all punches enter their respective dies. Punches should only enter dies enough to push out slugs, usually no more than 1/32".
- Clear slugs regularly.

OILING INFORMATION

- Apply light machine oil (SAE 10 or equivalent) to punch and guide area.
- Moly Kote® type 'GN' paste lubricant is applied to units shipped from factory.
- Lubricate unit components as necessary to ensure proper functioning.

REPLACE FATIGUED SPRINGS

- Check spring length. Fatigued springs usually take a 'set' and are visibly shorter than new springs.
- After normal use, fatigued springs may not have sufficient power to strip punches from work piece. If punches and dies are sharp and the unit is not stripping properly, it is most likely a worn stripping spring.

PUNCH SHARPENING

Punch and die life can be extended considerably by sharpening tools when an approximately .010" radius is on cutting edge. The number of holes produced between sharpenings will vary according to the material thickness and type being punched. As an example, from perhaps 500 to 1,000 holes in heavy material to 10,000 to 15,000 holes in 16 gauge (.0598)(1.6mm) 50,000-PSI mild steel. Using 16 gauge as an example, refer to the diagram below for proper sharpening to increase punch life.

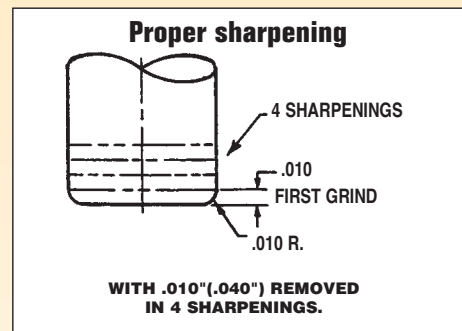
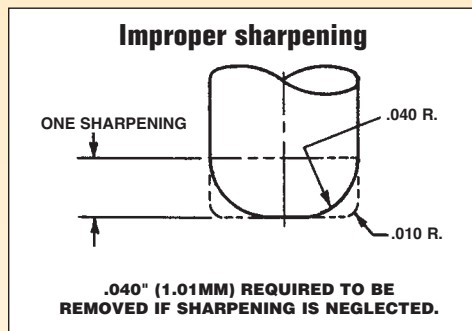

Note: Quantity of holes will vary considerably due to material hardness, proper die clearance or unit alignment.

GENERAL SHARPENING NOTES:

- Take light cuts when sharpening.
- Use soft coarse grinding wheel.
- Coolant should be used when sharpening cutting surfaces.

Required Dimensioning Specifications for common shapes

The shapes below are available for most hole punching units. When ordering, specify dimensions as shown. Refer to individual holder specifications for size limitations. Decimal and metric sizes are available at no additional cost.

<p>ROUND</p> <p>$S = A$ $P = 3.14A$</p>	<p>OBROUND</p> <p>$S = A$ $P = 2A + 1.14B$</p>	<p>RECTANGLE</p> <p>$S = \sqrt{A^2 + B^2}$ $P = 2A + 2B$</p>	<p>SINGLE "D"</p> <p>$S = A$ $P(\text{est}) = 1.57A + 2B$</p>	<p>DOUBLE "D"</p> <p>$S = A$ $P(\text{est}) = 2A + 2B$</p>	<p>SQUARE</p> <p>$S = 1.414B$ $P = 4B$</p>
<p>LONG "D"</p> <p>$S = [A^2/(4B)] + B$ $P = 2B + 1.57A$</p>	<p>HEXAGON</p> <p>$S = 1.155A$ $P = 3.46A$</p>	<p>OCTAGON</p> <p>$S = 1.082A$ $P = 8B + 3.313A$</p>	<p>$S = \text{Diameter}, P = \text{Perimeter}$</p> <p>As these shapes are illustrated, point 'X' is at 0 degrees of angular orientation.</p>		

How to Specify Angular Orientation for punches and dies

Most shaped punches and dies can be used in two positions at 90 degrees to each other. Angularity is measured from 0 to 360 degrees clockwise when viewed from the top. Zero degrees is at the front of the unit. See diagrams below.

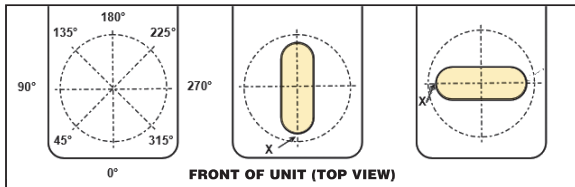

On the obround shape shown in the drawing, point 'X' is at 0 and 90 degrees.

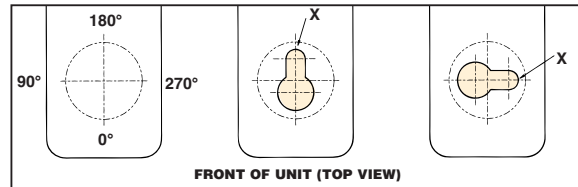

On the keyhole shape shown in this drawing, point 'X' is illustrated at 180 and 270 degrees.

Additional Examples of Orientation

When ordering any shape, specify at what angle you want point 'X'. On most holders standard keying is at 0 and 90 degrees; other angular settings are available upon request. Contact the UniPunch Sales Department for assistance.

<p>KEYHOLE 1200</p>	<p>BUTTERFLY 1201</p>	<p>1204</p>	<p>LONG "D" 1205</p>	<p>KEYHOLE 1206</p>	<p>SQUARE 45° 1209</p>
<p>EQUIL. TRIANGLE</p>	<p>DIAMOND</p>	<p>SQ. / DIA. CORNERS</p>	<p>Point 'X' refers to 0 degree position as operator faces front of holder.</p>		

Additional Shapes

Some of the special shapes we manufacture are shown below. A code number is provided for easy referencing when ordering. A fully dimensioned sketch should accompany all orders or inquiries. For shapes not shown below, contact the UniPunch Sales Department.

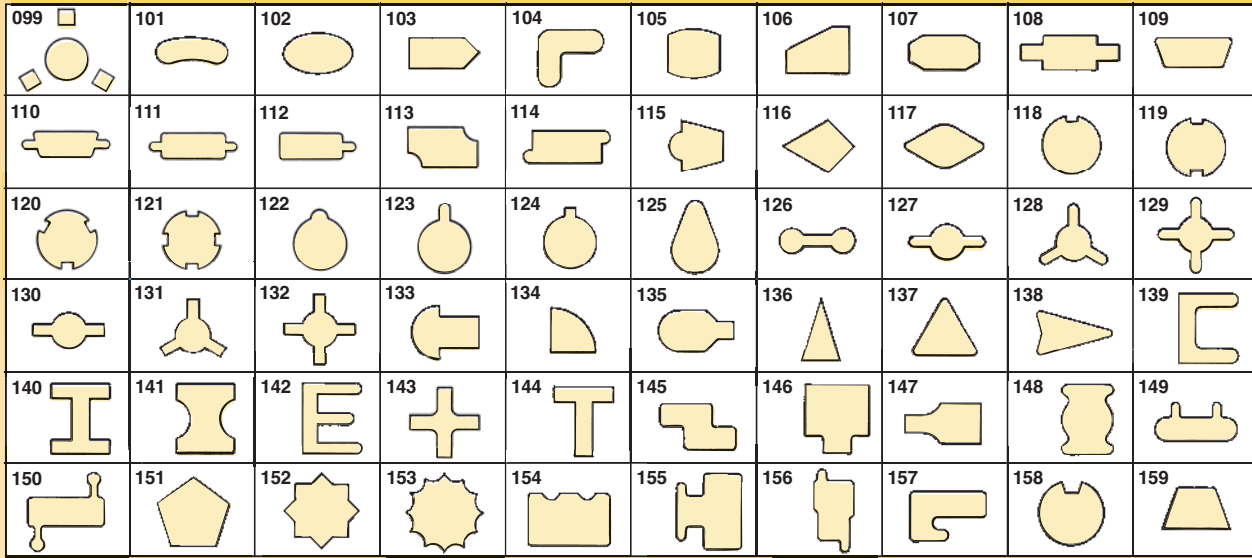

Other System Capabilities

In addition to hole punching, your product may require supplementary fabricating operations. Here are a few examples that can be accomplished with the UniPunch System. Contact the UniPunch Sales Department with your specific requirements.

<p>1251 Trim & Part (2 radii total) Specify part width and radius required.</p> <p>HEEL LENGTH 'A' SERIES = .38 'B' SERIES = .25</p> <p>Required Parameters A = Trim Radius C = Run Out Angle (5° to 10° Default) Material Type & Thickness (10 Ga. Max.)</p>	<p>1255 Corner Radius Specify radius required. (shown without heel gauging)</p> <p>Required Parameters A = Radius Material Type & Thickness (10 Ga. Max.)</p>
<p>Cluster Allows multiple hole patterns in one hit</p> <p>Required Parameters Hole sizes Hole centers Shaped Holes - Specify type of shape Material Thickness</p>	<p>Vee Notch</p> <p>Required Parameters Depth of Notch Angle of Notch Material Thickness</p>
<p>Lance and Form Form down</p> <p>Required Parameters Length Width Depth Material Thickness</p>	<p>Emboss Form down</p> <p>Required Parameters Diameter A = Angle Overall Height Material Thickness</p>

Heeled Punches

Recommended for notching the edge of the sheet metal. The heel of the punch engages into the die to stabilize the punch. When ordering, specify either obround or rectangle shape. Two variations of each are available as shown below.

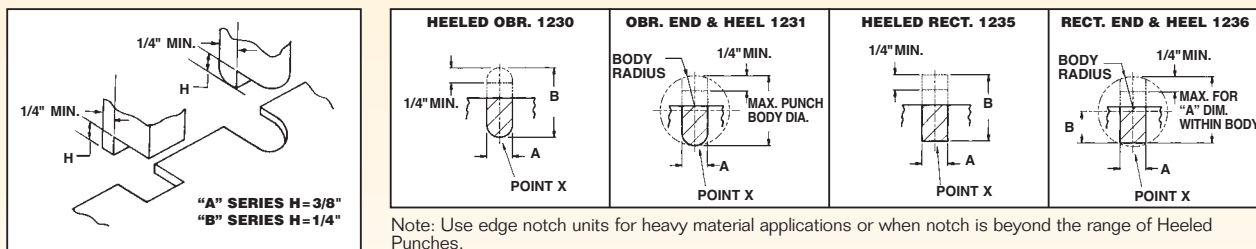

Note: Use edge notch units for heavy material applications or when notch is beyond the range of Heeled Punches.

For additional information on custom applications, visit the UniPunch website at www.unipunch.com/SystemCapabilities

Countersinking Holes for Flat Head Screws

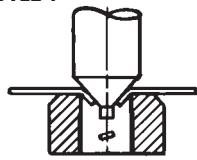
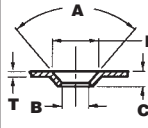
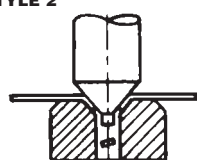
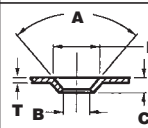
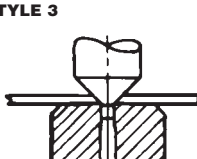
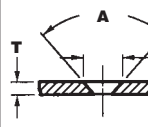

<p>STYLE 1</p> 	<p>Countersink punches with standard open die buttons as illustrated to the left are used in "A" or "B" Series units for countersinking up to 10 gauge mild steel to accept flat head screws. Die buttons have a .02" radius instead of cutting edge. "A" Series units with adjustable feed opening are recommended for easy removal of formed workpiece. The "B" unit feed clearance must be increased for removal of formed workpiece.*</p>	 <p>1261 Countersink (style 1)</p> <p>D - DIA. AT TOP SURFACE - TO INTERSECTING POINTS</p> <p>A = Angle B = Clearance Hole C = Overall Ht. (incl. material) D = Screw/Rivet Size (dia.) T = Thickness</p>
<p>STYLE 2</p> 	<p>The die shown at left allows the punch to bottom the countersink shape into the workpiece at the bottom of stroke. This die provides a more uniform countersink.*</p>	 <p>1262 Countersink (style 2)</p> <p>D - DIA. AT TOP SURFACE - TO INTERSECTING POINTS</p> <p>A = Angle B = Clearance Hole C = Overall Ht. (incl. material) D = Screw/Rivet Size (dia.) T = Thickness</p>
<p>STYLE 3</p> 	<p>The machined type of countersink is used in "A" or "B" Series standard units for countersinking up to 10 gauge material. The die shown at the left allows the punch and die to bottom the countersink shape into the workpiece at the bottom of the stroke.*</p> <p>Due to the nature of this style, material will deform and a burr will occur. The amount will vary according to material and specifications.</p>	 <p>1263 Countersink (style 3)</p> <p>A = Angle D = Screw/Rivet Size (dia.) T = Thickness</p>

***Note:** All of the above mentioned Countersinking Punches and Dies are **bottoming** operations and **extreme caution** must be taken in setting the proper shut height. Prices are available upon request from the UniPunch Sales Department. Specify size of screw, type of material and thickness when inquiring.

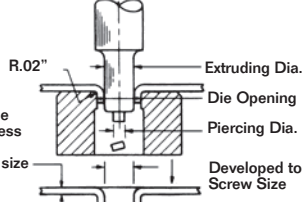
Extrusion Punches and Dies

 <p>When inquiring specify type and thickness of material and screw size</p>	<p>Special punches with oversize die buttons are used in standard "A" or "B" Series units to produce extruded holes to accept sheet metal screw or permit tapping in thicker material for machine screws. Die buttons have .02" radius instead of cutting edge. "A" Series units with adjustable feed opening are recommended for easy removal of formed workpiece. The "B" unit feed clearance must be increased for removal of formed workpiece. Prices are available upon request from the UniPunch Sales Department.</p>
---	--

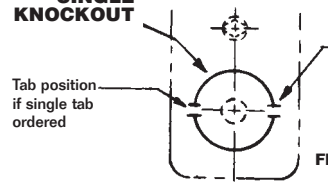
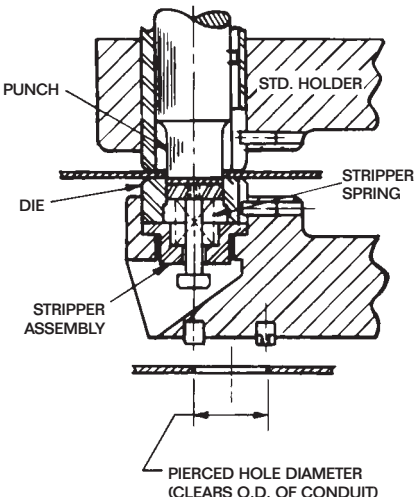
"A" & "B" Series Knockout Units

<p>SINGLE KNOCKOUT</p>  <p>Two tabs furnished unless otherwise specified. Punch and die are shaped for positive alignment of tabs and can be rotated 90°.</p> <p>Tab position if single tab ordered</p> <p>FRONT OF UNIT</p> <p>Standard units with modified punches and dies are used for forming single electrical knockouts. The dies have built-in strippers to force slug out of die for easy removal from unit. Maximum capacity 1/16" mild steel. When ordering, specify actual hole diameter, thickness of material and number of tabs (one or two).</p>	<p>TABLE OF PUNCH SIZES FOR STANDARD CONDUIT</p> <table border="1"> <thead> <tr> <th>Conduit Size (I.D.)</th> <th>Punch Size of Slip Hole</th> </tr> </thead> <tbody> <tr> <td>3/8</td> <td>1 1/16</td> </tr> <tr> <td>1/2</td> <td>7/8</td> </tr> <tr> <td>3/4</td> <td>1 1/8</td> </tr> <tr> <td>1</td> <td>1 3/8</td> </tr> <tr> <td>1 1/4</td> <td>1 3/4</td> </tr> <tr> <td>1 1/2</td> <td>2</td> </tr> <tr> <td>2</td> <td>2 1/2</td> </tr> <tr> <td>2 1/2</td> <td>3</td> </tr> <tr> <td>3</td> <td>3 5/8</td> </tr> </tbody> </table>	Conduit Size (I.D.)	Punch Size of Slip Hole	3/8	1 1/16	1/2	7/8	3/4	1 1/8	1	1 3/8	1 1/4	1 3/4	1 1/2	2	2	2 1/2	2 1/2	3	3	3 5/8	 <p>PUNCH STD. HOLDER DIE STRIPPER ASSEMBLY STRIPPER SPRING PIERCED HOLE DIAMETER (CLEARS O.D. OF CONDUIT)</p>
Conduit Size (I.D.)	Punch Size of Slip Hole																					
3/8	1 1/16																					
1/2	7/8																					
3/4	1 1/8																					
1	1 3/8																					
1 1/4	1 3/4																					
1 1/2	2																					
2	2 1/2																					
2 1/2	3																					
3	3 5/8																					
<p>DOUBLE KNOCKOUT</p>  <p>Double Knockout Units are made according to customer's specifications. When ordering, specify actual hole diameter, thickness of material, number and locations of tabs. Prices available upon request.</p>																						

Technical Data

Calculating Tonnage

How to Obtain Tonnage Required for Punching Round Holes:

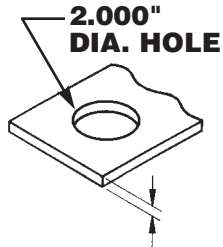

2.000" DIA. HOLE
1/4 (.250") THICK M.S.

FORMULA:

TONNAGE IN MILD STEEL =
3.1416 x DIA. OF HOLE x
MAT'L THICKNESS x 25

EXAMPLE:

3.1416 x 2.000 x .250 x 25

ANSWER:

39.26 TONS

How to Obtain Tonnage Required for Punching Shaped Holes:

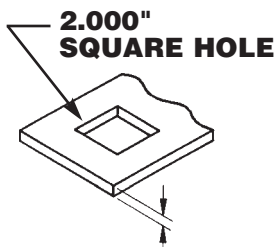

2.000" SQUARE HOLE
1/4 (.250") THICK M.S.

FORMULA:

TONNAGE IN MILD STEEL =
PERIPHERY x MATERIAL
THICKNESS x 25

EXAMPLE:

(2 + 2 + 2 + 2) x .250 x 25

ANSWER:

50 TONS

Approximate Tonnage Required for Punching Round Holes in Mild Steel (50,000 psi shear strength)

Hole Dia. in Inches	20 GA. .036	18 GA. .048	16 GA. .060	14 GA. .075	12 GA. .105	11 GA. .120	10 GA. .135	3/16 .187	1/4 .250	5/16 .312	3/8 .375	1/2 .500
1/8	.35	.47	.59	.74	1.0	1.2	—	—	—	—	—	—
3/16	.53	.71	.89	1.1	1.6	1.8	2.0	2.8	—	—	—	—
1/4	.71	.94	1.2	1.5	2.1	2.4	2.7	3.7	4.9	—	—	—
5/16	.88	1.2	1.5	1.9	2.6	3.0	3.3	4.6	6.2	7.8	—	—
3/8	1.1	1.4	1.8	2.2	3.1	3.5	4.0	5.5	7.4	9.2	11.1	—
7/16	1.2	1.7	2.1	2.6	3.6	4.1	4.6	6.5	8.6	10.8	13.0	17.2
1/2	1.4	1.9	2.4	2.9	4.1	4.7	5.3	7.4	9.8	12.3	14.8	19.7
9/16	1.6	2.1	2.7	3.3	4.7	5.3	6.0	8.3	11.0	13.8	16.6	22.1
5/8	1.8	2.4	2.9	3.7	5.2	5.9	6.6	9.2	12.3	15.4	18.5	24.6
11/16	1.9	2.6	3.2	4.1	5.7	6.5	7.3	10.2	13.5	16.9	20.3	27.1
3/4	2.1	2.8	3.5	4.4	6.2	7.1	8.0	11.1	14.8	18.4	22.1	29.5
13/16	2.3	3.1	3.8	4.8	6.7	7.7	8.6	12.0	16.0	20.0	24.0	32.0
7/8	2.5	3.3	4.1	5.2	7.2	8.3	9.3	12.9	17.2	21.5	25.8	34.4
15/16	2.7	3.5	4.4	5.5	7.7	8.8	10.0	13.8	18.5	23.0	27.7	36.9
1	2.8	3.8	4.7	5.9	8.3	9.4	10.6	14.8	19.7	24.6	29.5	39.4
1-1/2	4.2	5.6	7.0	8.8	12.3	14.1	15.8	22.1	29.5	36.8	44.2	58.9
2	5.6	7.5	9.4	11.7	16.4	18.8	21.1	29.5	39.3	49.1	58.9	78.5
2-1/2	7.1	9.4	11.7	14.7	20.5	23.6	26.4	36.8	49.1	61.4	73.6	98.2
3	8.5	11.3	14.1	17.6	24.6	28.2	31.7	44.2	58.9	73.6	88.4	118
3-1/2	9.9	13.1	16.4	20.5	28.8	32.7	37.0	51.5	68.7	85.9	103	137
4	11.3	15.0	18.8	23.5	32.8	37.6	42.2	58.9	78.5	98.2	118	157
4-1/2	12.7	16.9	21.2	26.4	37.0	42.4	47.5	66.3	88.4	110	133	177
5	14.1	18.7	23.5	29.3	41.1	47.1	52.8	73.6	98.2	123	147	196

To obtain tonnage required for punching round holes in mild steel multiply as follows:
3.1416 x Diameter of Hole x Material Thickness x 25 = Punching Tonnage Required for One Hole

Note: Additional tonnage is required to compress UniPunch units during the press down stroke. Contact the UniPunch Sales Department for stripping spring compression ratings for individual units.

Approximate Tonnage Required for Notching

Metal Thickness	Gauge	20	18	16	14	12	10	3/16"	1/4"	3/8"	1/2"
	Decimal	.036	.048	.060	.075	.105	.135	.187	.250	.375	.500
Tons Required to Notch 1" Length		.99	1.30	1.65	2.05	2.85	3.65	5.01	6.60	9.55	12.5

To obtain tonnage required for notching mild steel multiply as follows:
Total shear length x material thickness x 25 = tonnage required for total length of shear

Multiplier Chart for Various Materials

Above chart shows tonnage for punching holes in mild steel (50,000 psi). For punching materials of different shear strength, use multiplier in chart below.

Material Description	Tons Per Sq. In.	Yield or Shear Strength Per Sq. In.	Multiplier
Aluminum — Soft Sheet	7-1/2	15,000 psi	.30
Aluminum — Half Hard	9-1/2	19,000 psi	.38
Aluminum — Hard	12	25,000 psi	.50
Brass — Soft Sheet	15	30,000 psi	.60
Brass — Half Hard	17-1/2	35,000 psi	.70
Copper — Rolled	14	28,000 psi	.56
Steel — Mild	25	50,000 psi	1.00
Steel — ASTM - A36	30	60,000 psi	1.20
Steel — 50 Carbon	35	70,000 psi	1.40
Steel — Cold Drawn	30	60,000 psi	1.20
Steel — Stainless (18 - 8)	35	70,000 psi	1.40

Effect of Punch Shear on Tonnage

The chart at top shows tonnage for flat ground punches (without shear). Chisel shear on punches can considerably reduce required press tonnage. The chart below shows tonnage reduction factors for the shear depths listed.

Multiply shear factor times actual tonnage to obtain reduced tonnage per hole.

Shear Depth	Up to 16 GA.	14 GA.	12 GA.	10 GA.	8 GA.	3/16 GA.	1/4 GA.
1/16	.50	.60	.75	.80	.85	.87	.90
3/32	.50	.50	.60	.70	.75	.80	.85
3/16	.50	.50	.50	.50	.50	.50	.65

TECH. DATA

SPEED WITHIN REACH

UNIPUNCH

Twist Drills Letter and Number Sizes

Letter Sizes	Drill Diameter Inch	Number Sizes	Drill Diameter Inch	Number Sizes	Drill Diameter Inch	Number Sizes	Drill Diameter Inch
Z	0.413	1	0.2280	28	0.1405	55	0.0520
Y	0.404	2	0.2210	29	0.1360	56	0.0465
X	0.397	3	0.2130	30	0.1285	57	0.0430
W	0.386	4	0.2090	31	0.1200	58	0.0420
V	0.377	5	0.2055	32	0.1160	59	0.0410
U	0.368	6	0.2040	33	0.1130	60	0.0400
T	0.358	7	0.2010	34	0.1110	61	0.0390
S	0.348	8	0.1990	35	0.1100	62	0.0380
R	0.339	9	0.1960	36	0.1065	63	0.0370
Q	0.332	10	0.1935	37	0.1040	64	0.0360
P	0.323	11	0.1910	38	0.1015	65	0.0350
O	0.316	12	0.1890	39	0.0995	66	0.0330
N	0.302	13	0.1850	40	0.0980	67	0.0320
M	0.295	14	0.1820	41	0.0960	68	0.0310
L	0.290	15	0.1800	42	0.0935	69	0.0292
K	0.281	16	0.1770	43	0.0890	70	0.0280
J	0.277	17	0.1730	44	0.0860	71	0.0260
I	0.272	18	0.1695	45	0.0820	72	0.0250
H	0.266	19	0.1660	46	0.0810	73	0.0240
G	0.261	20	0.1610	47	0.0785	74	0.0225
F	0.257	21	0.1590	48	0.0760	75	0.0210
E	0.250	22	0.1570	49	0.0730	76	0.0200
D	0.246	23	0.1540	50	0.0700	77	0.0180
C	0.242	24	0.1520	51	0.0670	78	0.0160
B	0.238	25	0.1495	52	0.0635	79	0.0145
A	0.234	26	0.1470	53	0.0595	80	0.0135
		27	0.1440	54	0.0550		

Bend Allowance

Unless otherwise specified, the following bend allowances are used to calculate flat pattern developments for mounting template layouts:

GAUGE	DECIMAL	ALLOWANCE 1°	ALLOWANCE .90°	RADIUS**
24	.024	.00042	.038	.016
22	.030	.00045	.041	.016
20	.036	.00048	.044	.016
18	.048	.00055	.050	.016
16	.060	.00062	.056	.016
14	.075	.00097	.087	.031
12	.105	.00115	.103	.031
1/8	.125	.00180	.163	.062
10	.135	.00186	.168	.062
8	.164	.00203	.183	.062
3/16	.187	.00318	.286	.12
.229	.229	.00342	.308	.12
1/4	.250	.00354	.319	.12
5/16	.312	.00495	.446	.18
3/8	.375	.00532	.479	.18

**Use standard radius when no radius is specified on blueprint. When radius or thickness differs from chart, the following formulas will be used: B.A. for 1° = $(\pi T/3) + R$.01745 • B.A. for 90° = $(\pi T/3) + R$ 1.5708

T= Material Thickness, R=Bend Radius

When radius is greater than twice metal thickness, substitute T/2 in above formulas.

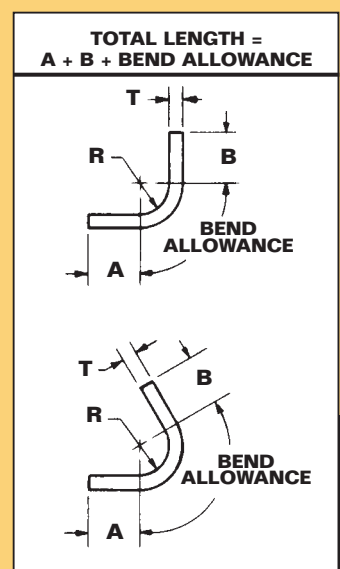

Technical Data

Decimal Equivalents

CONVERTING TO METRIC

TO CONVERT INCHES INTO MILLIMETERS, THE FOLLOWING FORMULA MAY BE USED:
 Decimal size (inches) x 25.4 = metric equivalent.

TO CONVERT MILLIMETERS INTO INCHES, THE FOLLOWING FORMULA MAY BE USED:
 Metric size (millimeters) ÷ 25.4 = decimal equivalent.

	Decimal	Millimeter
$\frac{1}{64}$	0.015625	0.397
$\frac{1}{32}$.03125	0.794
$\frac{3}{64}$.046875	1.191
$\frac{1}{16}$.0625	1.588
$\frac{5}{64}$.078125	1.984
$\frac{3}{32}$.09375	2.381
$\frac{7}{64}$.109375	2.778
$\frac{1}{8}$.1250	3.175
$\frac{9}{64}$.140625	3.572
$\frac{5}{32}$.15625	3.969
$\frac{11}{64}$.171875	4.366
$\frac{3}{16}$.1875	4.762
$\frac{13}{64}$.203125	5.159
$\frac{7}{32}$.21875	5.556
$\frac{15}{64}$.234375	5.953
$\frac{1}{4}$.2500	6.350
$\frac{17}{64}$.26565	6.747
$\frac{9}{32}$.28125	7.144
$\frac{19}{64}$.296875	7.541
$\frac{5}{16}$.3125	7.938
$\frac{21}{64}$.328125	8.334
$\frac{11}{32}$.34375	8.731
$\frac{23}{64}$.359375	9.128
$\frac{3}{8}$.3750	9.525
$\frac{25}{64}$.390625	9.922
$\frac{13}{32}$.40625	10.319
$\frac{27}{64}$.421875	10.716
$\frac{7}{16}$.4375	11.112
$\frac{29}{64}$.453125	11.509
$\frac{15}{32}$.46875	11.906
$\frac{31}{64}$.484375	12.303
$\frac{1}{2}$.5000	12.700

	Decimal	Millimeter
$\frac{33}{64}$.515625	13.097
$\frac{17}{32}$.53125	13.494
$\frac{35}{64}$.546875	13.891
$\frac{9}{16}$.5625	14.288
$\frac{37}{64}$.578125	14.684
$\frac{19}{32}$.59375	15.081
$\frac{39}{64}$.609375	15.478
$\frac{5}{8}$.6250	15.875
$\frac{41}{64}$.640625	16.272
$\frac{21}{32}$.65625	16.669
$\frac{43}{64}$.671875	17.066
$\frac{11}{16}$.6875	17.462
$\frac{45}{64}$.703125	17.859
$\frac{23}{32}$.71875	18.256
$\frac{47}{64}$.734375	18.653
$\frac{3}{4}$.7500	19.050
$\frac{49}{64}$.765625	19.447
$\frac{25}{32}$.78125	19.844
$\frac{51}{64}$.796875	20.241
$\frac{13}{16}$.8125	20.638
$\frac{53}{64}$.828125	21.034
$\frac{27}{32}$.84375	21.431
$\frac{55}{64}$.859375	21.828
$\frac{7}{8}$.8750	22.225
$\frac{57}{64}$.890625	22.622
$\frac{29}{32}$.90625	23.019
$\frac{59}{64}$.921875	23.416
$\frac{15}{16}$.9375	23.812
$\frac{61}{64}$.953125	24.209
$\frac{31}{32}$.96875	24.606
$\frac{63}{64}$.984375	25.003
1	1.000	25.400

Die Clearance for UniPunch Modular Tooling

By definition, Die Clearance is the space between the cutting edge of the punch and the cutting edge of the die. Optimal die clearance is determined by the thickness and type of the material being punched. Many studies have been made throughout the metalworking industry regarding the proper amount of die clearance and the results differ due to the many variables such as type and hardness of material being punched, type and speed of the press equipment and the design of the tooling itself. Through continued research and experience, we have arrived at the following recommendations for die clearance.

What Die Clearances should be used?

Longer tool life, reduced stripping force and good hole quality are directly related to the selection of proper die clearance. Material characteristics such as type, thickness and shear strength are factors that determine what die clearance should be used. The following are guidelines for punching various material types. For questions regarding your specific material punching application, contact the UniPunch Sales Department.

MILD STEEL

The total die clearance of 20% of material thickness is used when punching mild steel (50,000 psi) material. This die clearance provides maximum punch and die life, requires less stripping pressure and minimum press tonnage, which is an important feature when using multiple UniPunch units in setups.

ALUMINUM, COPPER AND BRASS

The total die clearance of 15% of material thickness is recommended for low shear strength materials and soft materials that tend to drag on punches and dies.

STAINLESS STEEL

When punching high shear strength materials such as stainless steel, we recommend 25% of the material thickness for die clearance. This helps to reduce punching tonnage and will aid in increasing tooling life.

Visit our website at www.unipunch.com and click the Tech Support tab for our online Die Clearance calculator.

PUNCH & DIE CLEARANCE

- 1) **WHAT IS DIE CLEARANCE?**
It is the dimensional difference between the punch & die.
- 2) **INDUSTRY STD. -**
always total clearance
- 3) **UNITIZED TOOLING STANDARD**
is usually 20% of material thickness for 50,000 p.s.i. mild steel

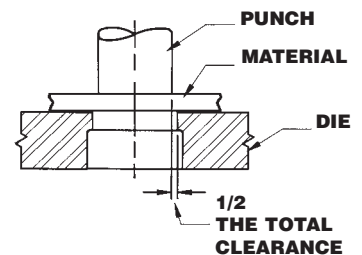

EXAMPLE:
.060 THICK MILD STEEL
1.000 DIA. PUNCH
DIE CLEARANCE = .060" X 20% = .012"
DIE SIZE = 1.012

How Often Should Punches and Dies be Sharpened?

Punch and Die life can be extended considerably by prudent sharpening at the ideal time. The number of holes produced between sharpening will vary according to the material thickness and hardness. Punches typically require more frequent sharpening than die buttons by almost two to one.

On a new or sharpened punch or die, the shearing edges are square and sharp. These edges are rather fragile considering that they must withstand the impact and tonnage required fracturing the material being punched. After considerable punching, observation of this edge will show a slight rounding (approximately .010"/.015" radius), and will have a frosted appearance. This

indicates that the metal in the immediate vicinity is fatigued. At this time the punch and die should be sharpened.

Tools not sharpened at the proper time will also allow tool edges to deteriorate rapidly and create extreme pressure on the cutting edges and will increase punching pressure requirements. This in turn will decrease quality and quantity of holes produced along with creating poor stripping conditions in the unit.

Therefore, frequent sharpening and minimum material removal is by far the least expensive and produces consistent high quality holes.

Material Technical Information

SPECIFICATION FOR COMMON MATERIALS AND RECOMMENDED DIE CLEARANCE

DESCRIPTION	HARDNESS	SHEAR STRENGTH		MATERIAL MULTIPLIER	RECOMMENDED DIE CLEARANCE IN % OF THICKNESS
		PSI	N / mm ²		
Steels					
Low Carbon HR Sheet	Rb 70	50,000	345	1.00	20%
Low Carbon C.R. Sheet	Rb	40,000	276	.80	20%
ASTM A-36	BHN 119-159	58-80,000		1.20	20-25%
45-50 Carbon HR Sheet	BHN 200	80,000	552	1.60	25%
Spring Steel 1074, 1095					
Hardened to Spring Temper	Rc 45-50	200,000	1.380	4.0	30%
COR-TEN Steel	BHN 120	55,000	379	1.1	20%
Aluminum Base Alloy(s) And Tempers(s)					
1100-0	BHN 23	9,000	62	.18	15%
1100-H14	BHN 32	11,000	76	.22	18%
2024-0	BHN 47	18,000	124	.36	18%
2024-T3	BHN 120	41,000	283	.82	20%
3003-0	BHN 28	11,000	76	.76	15%
3003-H14, H16	BHN 40-47	15,000	103	.30	18%
3105-H25	BHN 47	16,000	110	.32	18%
5005-H34	BHN 41	14,000	97	.28	18%
5052-0	BHN 47	18,000	124	.36	18%
5052-H32	BHN 60	20,000	138	.40	20%
6061-0	BHN 30	12,000	83	.24	15%
6061-T6	BHN 95	30,000	207	.60	20%
7075-0	BHN 60	22,000	152	.44	20%
7075-T6	BHN 150	48,000	331	.96	20%
Copper Base Alloys & Tempers					
110 Electrolytic Copper					
- .050 mm GS	Rb 40	22,000	152	.44	15%
- ½ Hard	Rb 40	26,000	179	.52	20%
- Hard	Rb 50	28,000	193	.56	25%
220 Comm Bronze 90%					
- ½ Hard	Rb 55	35,000	241	.70	15%
230 Red Brass 85%					
- ¼ Hard	Rb 55	35,000	241	.70	15%
260 Cartridge Brass					
- .035 mm Gs	Rb 68	34,000	234	.68	15%
- ½ Hard	Rb 70	40,000	276	.80	18%
- Spring	Rb 91	48,000	331	.96	20%
342 A High Lead - ½ Hard	Rb 70	40,000	276	.80	18%
675 Manganese Bronze	Rb 65	42,000	290	.84	18%
Stainless Steel					
202 Annealed	Rb 95	90,000	620	1.8	} .024-.048" (0.5-1.5mm) .060-.120" (1.5-3.0mm) over .120" (3.0mm)
302,303, 304 Annealed	Rb 85	75,000	517	1.5	
310 Annealed	Rb 90	90,000	620	1.8	
316,321,430 Annealed	Rb 90	75,000	517	1.5	
410 Annealed	Rb 85	75,000	517	1.5	
Other					
Titanium - Unalloyed	Rb 23-29	50,000	345	1.20	25%

METAL GAUGES IN DECIMALS OF AN INCH

Use the chart below to convert standard gauge numbers in decimals of an inch for sheet steel, aluminum and stainless steel.

Gauge #	Sheet Steel	Aluminum	Stainless Steel
1	—	.2893 (7.3)	.2812 (7.1)
2	—	.2576 (6.5)	.2656 (6.7)
3	.2391 (6.1)	.2294 (5.8)	.2500 (6.4)
4	.2242 (5.7)	.2043 (5.2)	.2344 (6.0)
5	.2092 (5.3)	.1819 (4.6)	.2187 (5.6)
6	.1943 (4.9)	.1620 (4.1)	.2031 (5.2)
7	.1793 (4.6)	.1443 (3.7)	.1875 (4.8)
8	.1644 (4.2)	.1285 (3.3)	.1719 (4.4)
9	.1495 (3.8)	.1144 (2.9)	.1562 (4.0)
10	.1345 (3.4)	.1019 (2.6)	.1406 (3.6)
11	.1196 (3.0)	.0907 (2.3)	.1250 (3.2)
12	.1046 (2.7)	.0808 (2.1)	.1094 (2.8)
13	.0897 (2.3)	.0720 (1.8)	.0937 (2.4)
14	.0747 (1.9)	.0641 (1.6)	.0781 (2.0)
15	.0673 (1.7)	.0571 (1.5)	.0703 (1.8)
16	.0598 (1.5)	.0508 (1.3)	.0625 (1.6)
17	.0538 (1.4)	.0453 (1.2)	.0562 (1.4)
18	.0478 (1.2)	.0403 (1.0)	.0500 (1.3)
19	.0418 (1.1)	.0359 (0.9)	.0437 (1.1)
20	.0359 (0.9)	.0320 (0.8)	.0375 (1.0)
21	.0329 (0.8)	.0285 (0.7)	.0344 (0.9)
22	.0299 (0.8)	.0253 (0.6)	.0312 (0.8)
23	.0269 (0.7)	.0226 (0.6)	.0281 (0.7)
24	.0239 (0.6)	.0201 (0.5)	.0250 (0.6)
25	.0209 (0.6)	.0179 (0.5)	.0219 (0.6)
26	.0179 (0.5)	.0159 (0.4)	.0187 (0.5)
27	.0164 (0.4)	.0142 (0.4)	.0172 (0.4)
28	.0149 (0.4)	.0126 (0.3)	.0156 (0.4)
29	.0135 (0.3)	.0113 (0.3)	.0141 (0.3)

Dimension in inches (millimeters)

Optional Punch Features

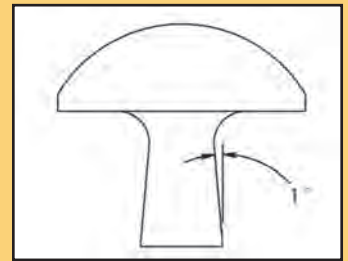

Back Taper on punch tips helps to reduce galling and stripping problems when punching stainless steel or thick material.

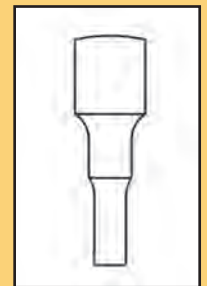

Stub Tip design is recommended on small punch sizes to help prevent breakage.

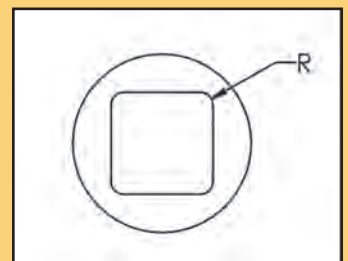

Radius Corners on square or rectangle punches prevents chipping or cracking on corners. Also beneficial by reducing stress to die corners.

Slot Sizes & Location

A, AJ, AH, OA-6 and AD Holders

A, AH Holder

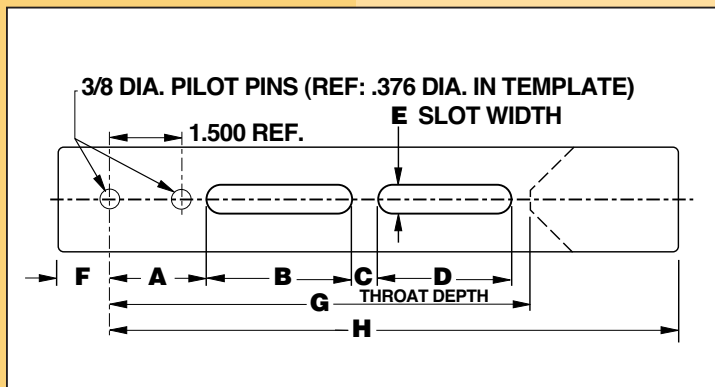

HOLDER	A	B	C	D	E	F	G	H
8AH-2 1/2	2	5	—	—	9/16	3 3/8	8 1/2	12
12AH-2 1/2	2	5	1	3 3/8	9/16	3 3/8	12 1/2	16
18AH-2 1/2	2	5	1	5 7/8	9/16	3 3/8	18 1/2	22
8AH-3	2 3/8	4 5/8	—	—	9/16	3 5/16	8 1/2	11 5/8
12AH-3	2 3/8	4 5/8	1	3 3/8	9/16	3 5/16	12 1/2	15 5/8
8AH-3 1/2	3	3 3/4	—	—	9/16	3 3/4	8 1/2	12
12AH-3 1/2	3	3 3/4	1	3 3/8	9/16	3 3/4	12 1/2	16
18AH-3 1/2	3	3 3/4	1	5 7/8	9/16	3 3/4	18 1/2	22
8AH-6	3 3/4	3 3/4	—	—	9/16	4 3/4	8 1/2	12 1/2
12AH-6	3 3/4	3 3/4	1	3 3/8	9/16	4 3/4	12 1/2	16 1/2
18AH-6	3 3/4	3 3/4	1	5 7/8	9/16	4 3/4	18 1/2	22 1/2
8 OA-6	3 11/16	3 3/4	—	—	9/16	4 13/16	8 1/2	12 1/2
12 OA-6	3 11/16	3 3/4	1	3 3/8	9/16	4 13/16	12 1/2	16 1/2
18 OA-6	3 11/16	3 3/4	1	5 7/8	9/16	4 13/16	18 1/2	22 1/2

HOLDER	A	B	C	D	E	F	G	H
4A-1	1 7/8	1 7/8	—	—	9/16	5/8	4 1/8	7
8A-1	1 7/8	2 5/8	5/8	2 5/8	9/16	5/8	8 1/8	11
12A-1	1 7/8	2 5/8	5/8	2 5/8	9/16	5/8	12 1/8	15
4A-1 1/4	1 7/8	1 7/8	—	—	9/16	5/8	4 1/8	7
8A-1 1/4	1 7/8	5 7/8	—	—	9/16	5/8	8 1/8	11
12A-1 1/4	1 7/8	5 7/8	1/2	3 1/2	9/16	5/8	12 1/8	15
4A-1 1/2	1 7/8	1 7/8	—	—	9/16	3/4	4 1/8	7
8A-1 1/2	1 7/8	5 7/8	—	—	9/16	3/4	8 1/8	11
12A-1 1/2	1 7/8	5 7/8	1/2	3 1/2	9/16	3/4	12 1/8	15
18A-1 1/2	1 7/8	5 7/8	1/2	5 7/8	9/16	3/4	18 1/8	21
4A-2	1 7/8	1 7/8	—	—	9/16	1	4 1/8	7
8A-2	1 7/8	5 7/8	—	—	9/16	1	8 1/8	11
12A-2	1 7/8	5 7/8	1/2	3 1/2	9/16	1	12 1/8	15
18A-2	1 7/8	5 7/8	1/2	5 7/8	9/16	1	18 1/8	21
4A-2 1/2	1 7/8	1 7/8	—	—	9/16	1 3/8	4 1/8	7
8A-2 1/2*	1 7/8	5 7/8	—	—	9/16	1 3/8	8 1/8	11
12A-2 1/2*	1 7/8	5 7/8	1/2	3 1/2	9/16	1 3/8	12 1/8	15
18A-2 1/2*	1 7/8	5 7/8	1/2	5 7/8	9/16	1 3/8	18 1/8	21
8A-3 1/2	2 7/8	4	—	—	9/16	2 3/8	8 1/4	11 3/4
12A-3 1/2	2 7/8	4	1	2 1/2	9/16	2 3/8	12 1/4	15 3/4
18A-3 1/2	2 7/8	6	1	4 1/2	9/16	2 3/8	18 1/4	21 3/4
8A-5 1/2	3 1/2	3 3/4	—	—	9/16	3	8 1/4	12 1/4
12A-5 1/2	3 1/2	3 3/4	1	3	9/16	3	12 1/4	16 1/4
18A-5 1/2	3 1/2	3 3/4	1	6	9/16	3	18 1/4	22 1/4

*on AJ-2 1/2 units "A" dimension is 2 1/8", "B" & "D" dimensions are 5 5/8".

AD Holder

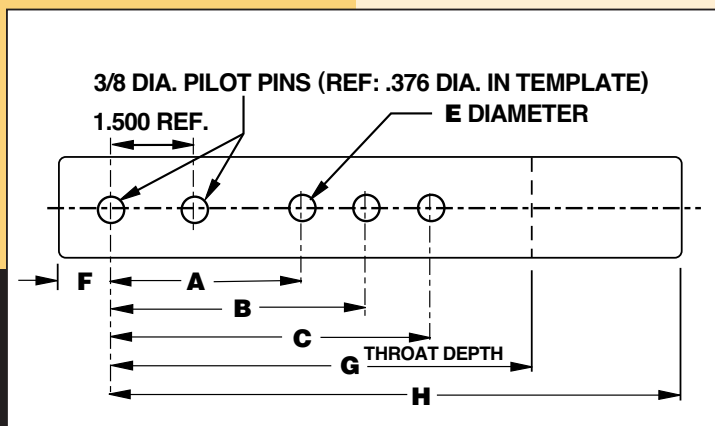

HOLDER	A	B	C	E	F	G	H
8 AD-4	3 3/8	4 7/8	6 3/8	5/8	3 3/4	8 1/4	11 3/4
12 AD-4	3 3/8	4 7/8	6 3/8	5/8	3 3/4	12 1/4	15 3/4
18 AD-4	3 3/8	4 7/8	6 3/8	5/8	3 3/4	18 1/4	21 3/4

TEMPLATE LAYOUT DESIGN INFORMATION

UniPunch can provide CAD files of units for use in creating templates. The formats that are available are DXF (2D footprint), DWG (2D footprint) and STEP (3D model). STEP files are available to download and are located in our Online Parts Book at www.unipunch.com or by contacting the UniPunch Sales Department.

B and BX Holders

Slot Sizes & Location

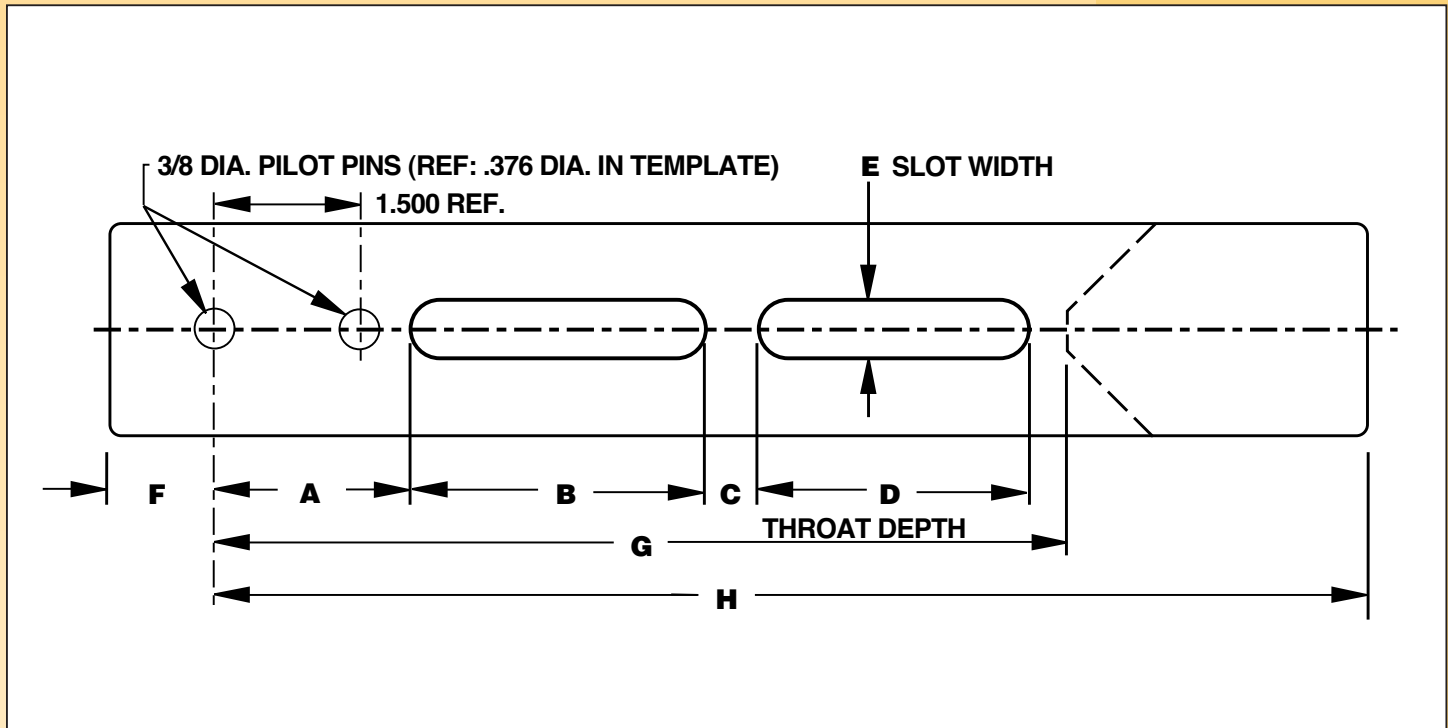

HOLDER	A	B	C	D	E	F	G	H
4BX-3/4	1 3/4	2	—	—	3/8	1 1/8	4 1/8	7
8BX-3/4	1 3/4	2 5/8	5/8	2 5/8	3/8	1 1/8	8 1/8	11
4B-1	1 7/8	2	—	—	9/16	1 1/4	4 1/8	7
8B-1	1 7/8	2 5/8	5/8	2 5/8	9/16	1 1/4	8 1/8	11
4B-1 1/4	1 7/8	1 7/8	—	—	9/16	3/4	4 1/8	7
8B-1 1/4	1 7/8	5 7/8	—	—	9/16	3/4	8 1/8	11
12B-1 1/4	1 7/8	5 7/8	1/2	3 1/2	9/16	3/4	12 1/8	15
4B-1 3/4	1 7/8	1 7/8	—	—	9/16	1	4 1/8	7
8B-1 3/4	1 7/8	5 7/8	—	—	9/16	1	8 1/8	11
12B-1 3/4	1 7/8	5 7/8	1/2	3 1/2	9/16	1	12 1/8	15
18B-1 3/4	1 7/8	5 7/8	1/2	5 7/8	9/16	1	18 1/8	21
4BX-2 1/4	1 7/8	1 7/8	—	—	9/16	1 1/4	4 1/8	7
8BX-2 1/4	1 7/8	5 7/8	—	—	9/16	1 1/4	8 1/8	11
12BX-2 1/4	1 7/8	5 7/8	1/2	3 1/2	9/16	1 1/4	12 1/8	15
18BX-2 1/4	1 7/8	5 7/8	1/2	5 7/8	9/16	1 1/4	18 1/8	21
8B-3	1 7/8	5 7/8	—	—	9/16	1 5/8	8 1/8	11
12B-3	1 7/8	5 7/8	1/2	3 1/2	9/16	1 5/8	12 1/8	15
18B-3	1 7/8	5 7/8	1/2	5 7/8	9/16	1 5/8	18 1/8	21
8B-5	4 3/8	3	—	—	9/16	3	8 1/4	11 3/4
12B-5	4 3/8	3	1 1/4	3	9/16	3	12 1/4	15 3/4
18B-5	4 3/8	4 1/2	2	4 1/2	9/16	3	18 1/4	21 3/4

Unittool

Tooling and Units to replace Unittool H, HA/HP, HH, and M Series

Compatible with existing Unittool heavy duty and medium duty holders, UniPunch units can utilize existing punches, dies and other components, and can be used right next to a Unittool holder without any modification in existing mounting setups. All shut heights and die heights are uniform.

Visit the UniPunch website and select the Online Parts Book tab for cross-reference information by unit model or part number.
www.unipunch.com/PartsBook



Assemblies and replacement parts

UniPunch provides high quality assemblies and replacement parts for Unittool H & M Series Units, mounting equipment, accessories and other products. For complete information, simply call the number below.

The UniPunch Advantage

- A-2 5% chrome, air-hardening tool steel is used to provide longer punch life in our "A" and "B" Series units. This means less tool maintenance and better resistance to chipping and cracking.

- Heavy-duty die springs supplied in all "A" and "AH" Series units for increased stripping pressure.
- Toll-free 800 number for assistance in ordering and technical questions.
- Fax and email service directly linked to our specials/quotations department for easy transmittal of drawings and quick answers on tooling requirements.
- Thoroughly experienced engineering department with many years of practical experience in punch and die design.

UNI-PUNCH SELECTION CHART

Unittool Series	UniPunch Equivalent	Maximum Diameter	Max. Mat'l Thickness
H	A	3.500"	1/4"
HA/HP	AJ	1.250"	1/4"
HH	AH	3.000"	1/2"
M	B	3.500"	10 GA.
H Corner Notch Units—Ref. UniPunch "A" Series		H2P Horizontal Units—Ref. UniPunch "HZ" Series	
M Corner Notch Units—Ref. UniPunch "B" Series		L Light Duty Units—Ref. UniPunch "G" Series	

REPL. TOOLING

A-1 Unit Interchangeable with H-1

SPECIFICATIONS:

MAX. PUNCH DIA.: .4375" (11.11mm)	MIN. PUNCH DIA.: .0937" (2.4mm)
MAX. SQUARE: .309" (7.85mm)	MIN. SHAPE DIM.: .0937" (2.4mm)

COMPLETE ROUND UNITS		
Model No.	Part No.	Unittool Ref.
4A-1	2003	4H-1
8A-1	2000	8H-1
12A-1	2001	12H-1

COMPLETE SHAPED UNITS		
Model No.	Part No.	Unittool Ref.
4SA-1	2005	4H-1K
8SA-1	2006	8H-1K
12SA-1	2007	12H-1K

Replacement Components	Unittool Ref. No.	UniPunch Part No.
Punch Head	HPH-107	2075
Round Punch	HP-122	2111
Round Punch with Head	HPA-102A	2011
Shaped Punch with Head	HPA-102K	2016
Stripping Spring	HSS-105	2045
Punch Retainer	PR-100	2180
Round Guide	HG-104	2030
Shaped Guide	HG-104K	2035
Lifter Spring	HLS-106	2070
Round Die	HD-123	2120
Shaped Die	HD-123K	2125
Guide Retainer	GR-300	1002
Guide Retainer Screw	—	91130
Pilot Pin (round)	PP-1000	1001
Pilot Pin (diamond)	PP-1000K	1101

For additional components and specifications - ref. A-1 catalog page 22

A-1¼ Unit Interchangeable with H-1¼

SPECIFICATIONS:

MAX. PUNCH DIA.: .4375" (11.11mm)	MIN. PUNCH DIA.: .0937" (2.4mm)
MAX. SQUARE: .309" (7.85mm)	MIN. SHAPE DIM.: .0937" (2.4mm)

COMPLETE ROUND UNITS		
Model No.	Part No.	Unittool Ref.
4A-1¼	2103	4H-1¼
8A-1¼	2100	8H-1¼
12A-1¼	2101	12H-1¼

COMPLETE SHAPED UNITS		
Model No.	Part No.	Unittool Ref.
4SA-1¼	2105	4H-1¼K
8SA-1¼	2106	8H-1¼K
12SA-1¼	2107	12H-1¼K

Replacement Components	Unittool Ref. No.	UniPunch Part No.
Punch Head	HPH-127	2171
Round Punch	HP-122	2111
Round Punch with Head	HPA-122A	2110
Shaped Punch with Head	HPA-122K	2115
Stripping Spring	HSS-125	2140
Punch Retainer	PR-100	2180
Round Guide	HG-124	2130
Shaped Guide	HG-124K	2135
Lifter Spring	HLS-126	2170
Round Die	HD-123	2120
Shaped Die	HD-123K	2125
Guide Retainer	GR-300	1002
Guide Retainer Screw	—	91130
Pilot Pin (round)	PP-1000	1001
Pilot Pin (diamond)	PP-1000K	1101

For additional components and specifications - ref. A-1¼ catalog page 23

Interchangeable with Unittool

A-1½ Unit Interchangeable with H-1½

SPECIFICATIONS:

MAX. PUNCH DIA.: .6250" (15.87mm)

MAX. SQUARE: .441" (11.20mm)

MIN. PUNCH DIA.: .1250" (3.18mm)

MIN. SHAPE DIM.: .0937" (2.38mm)

COMPLETE ROUND UNITS		
Model No.	Part No.	Unittool Ref.
4A-1½	2203	4H-1½
8A-1½	2200	8H-1½
12A-1½	2201	12H-1½

COMPLETE SHAPED UNITS		
Model No.	Part No.	Unittool Ref.
4SA-1½	2205	4H-1½K
8SA-1½	2206	8H-1½K
12SA-1½	2207	12H-1½K

Replacement Components	Unittool Ref. No.	UniPunch Part No.
Punch Head	HPH-157	2271
Round Punch	HP-152	2211
Round Punch with Head	HPA-152A	2210
Shaped Punch with Head	HPA-152K	2215
Stripping Spring	HSS-155	2240
Punch Retainer	PR-100	2180
Round Guide	HG-154	2230
Shaped Guide	HG-154K	2235
Lifter Spring	HLS-156	2270
Round Die	HD-153	2220
Shaped Die	HD-153K	2225
Guide Retainer	GR-300	1002
Guide Retainer Screw	—	91130
Pilot Pin (round)	PP-1000	1001
Pilot Pin (diamond)	PP-1000K	1101

For additional components and specifications - ref. A-1½ catalog page 24

A-2 Unit Interchangeable with H-2

SPECIFICATIONS:

MAX. PUNCH DIA.: .8750" (22.22mm)

MAX. SQUARE: .618" (15.69mm)

MIN. PUNCH DIA.: .1875" (4.76mm)

MIN. SHAPE DIM.: .1250" (3.18mm)

COMPLETE ROUND UNITS		
Model No.	Part No.	Unittool Ref.
4A-2	2303	4H-2
8A-2	2300	8H-2
12A-2	2301	12H-2

COMPLETE SHAPED UNITS		
Model No.	Part No.	Unittool Ref.
4SA-2	2305	4H-2K
8SA-2	2306	8H-2K
12SA-2	2307	12H-2K

Replacement Components	Unittool Ref. No.	UniPunch Part No.
Punch Head	HPH-207	2371
Round Punch	HP-202	2311
Round Punch with Head	HPA-202A	2310
Shaped Punch with Head	HPA-202K	2315
Stripping Spring	HSS-205	2340
Punch Retainer	PR-100	2180
Round Guide	HG-204	2330
Shaped Guide	HG-204K	2335
Lifter Spring	HLS-206	2370
Round Die	HD-203	2320-2
Round Die (with collar)	HD-203	2320-1
Shaped Die	HD-203K	2325-2
Shaped Die (with collar)	HD-203K	2325-1
Guide Retainer	GR-300	1002
Guide Retainer Screw	—	91130
Pilot Pin (round)	PP-1000	1001
Pilot Pin (diamond)	PP-1000K	1101

For additional components and specifications - ref. A-2 catalog page 25

A-2½ Unit Interchangeable with H-2½

SPECIFICATIONS:

MAX. PUNCH DIA.: 1.5000" (38.10mm) MIN. PUNCH DIA.: .2812" (7.15mm)

MAX. SQUARE: 1.060" (26.92mm) MIN. SHAPE DIM.: .1250" (3.18mm)

COMPLETE ROUND UNITS		
Model No.	Part No.	Unittool Ref.
4A-2½	2400	4H-2½
8A-2½	2401	8H-2½
12A-2½	2402	12H-2½
18A-2½	2403	18H-2½

COMPLETE SHAPED UNITS		
Model No.	Part No.	Unittool Ref.
4SA-2½	2405	4H-2½K
8SA-2½	2406	8H-2½K
12SA-2½	2407	12H-2½K
18SA-2½	2408	18H-2½K

Replacement Components	Unittool Ref. No.	UniPunch Cat. No.
Punch Screw	PS-259	2485
Punch Driver	HPH-257A	2484
Stripping Spring (set of 10)	HSS-255	2440-10
Spring Guard	SG-250	2442
Round Guide	HG-254	2435
Shaped Guide	HG-254K	2435
Lifter Spring	HLS-256	2470
Round Punch	HP-252	2411
Shaped Punch	HP-252K	2416
Round Die	HD-253	2420
Shaped Die	HD-253K	2425
Guide Retainer	GR-300	1002
Guide Retainer Screw	—	91130
Pilot Pin (round)	PP-1000	1001
Pilot Pin (diamond)	PP-1000K	1101

For additional components and specifications - ref. A-2½ catalog page 26

Tooling For H-3 Unit

Not Available

Tooling For H-3 1/2 Unit

SPECIFICATIONS:

MAX. PUNCH DIA.: 2.0000" (50.8mm) MIN. PUNCH DIA.: .5000" (12.70mm)

MAX. SQUARE: 1.414" (35.92mm) MIN. SHAPE DIM.: .1250" (3.18mm)

**Note: No Interchangeable Units are available
Replacement Punches & Dies listed below**

Replacement Components	Unittool Ref. No.	UniPunch Part No.
Round Punch	HP-352	2510
Shaped Punch	HP-352K	2517
Round Die	HD353	2520
Shaped Die	HD-353K	2525
Guide Retainer	GR-300	1002
Guide Retainer Screw	—	91130
Pilot Pin (round)	PP-1000	1001
Pilot Pin (diamond)	PP-1000K	1101

H-Series Corner Notch Units Interchangeable with A-Series

3" x 3"		
Replacement Components	Unittool Ref. No.	UniPunch Part No.
Left Hand Corner Notch	H-33-LCN	6440
Right Hand Corner Notch	H-33-RCN	6450

5" x 5"		
Replacement Components	Unittool Ref. No.	UniPunch Part No.
Left Hand Corner Notch	H-55-LCN	6010
Right Hand Corner Notch	H-55-RCN	6020

REPL. TOOLING

For additional components and specifications - ref. A-Series Corner Notch Page 48

Note: Unittool Series 200 Post Design Notch Units are not available

Interchangeable with Unittool

Tooling For H-5 3/4 Unit

SPECIFICATIONS:

MAX. PUNCH DIA.: 3.5000" (88.90mm)	MIN. PUNCH DIA.: 1.2500" (31.75mm)
MAX. SQUARE: 2.474" (62.84mm)	MIN. SHAPE DIM.: .1250" (3.18mm)

**Note: No Interchangeable Units are available
Replacement Punches & Dies listed to right**

Replacement Components	Unittool Ref. No.	UniPunch Part No.
Round Punch: From 1.2500" to 1.5625" From 1.5630" to 2.2500" From 2.2510" to 2.8750" From 2.8760" to 3.5000"	MP-502A MP-502B MP-502C MP-502D	8207 8208 8209 8210
Shaped Punch: Within 1.5000" Dia. Within 2.5000" Dia. Within 3.5000" Dia.	MP-502AK MP-502CK MP-502DK	8282 8283 8284
Round Stripper Plate (Specify Punch Size)	MSP-509	8271
Fitted Stripper Plate (Specify Punch Size & Shape)	MSP-509K	8270
Round Die	HD-603	3820
Shaped Die	HD-603K	3825
Punch Locator (For Rd. Punches 1.563 Dia. to 3.500 Dia.)	PR-500	3880
Pilot Pin (round)	PP-1000	1001
Pilot Pin (diamond)	PP-1000K	1101

Tooling for H-8 Unit

Not Available. See UniPunch A-8 for compatible unit page 29

H-Series Edge & Vee Notch Units Interchangeable with A-Series

see A Series Notch Unit pages 49 - 50

AJ-1 Unit Interchangeable with HA-1/HP-1

SPECIFICATIONS:

MAX. PUNCH DIA.: .4375" (11.11mm)	MIN. PUNCH DIA.: .0937" (2.38mm)
MAX. SQUARE: .309" (7.85mm)	MIN. SHAPE DIM.: .0937" (2.38mm)

STANDARD UNITS (Complete With Punch, Die Button & Adapter)					
COMPLETE ROUND UNITS			COMPLETE SHAPED UNITS		
Model No.	Part No.	Unittool Ref.	Model No.	Part No.	Unittool Ref.
4AJ-1A	14000A	4HA-1	4SAJ-1A	14005A	4HA-1K
8AJ-1A	14001A	8HA-1	8SAJ-1A	14006A	8HA-1K
12AJ-1A	14002A	12HA-1	12SAJ-1A	14007A	12HA-1K

OPTIONAL UNITS (Complete With Punch & Pedestal Die)					
COMPLETE ROUND UNITS			COMPLETE SHAPED UNITS		
Model No.	Part No.	Unittool Ref.	Model No.	Part No.	Unittool Ref.
4AJ-1P	14000P	4HP-1	4SAJ-1P	14005P	4HP-1K
8AJ-1P	14001P	8HP-1	8SAJ-1P	14006P	8HP-1K
12AJ-1P	14002P	12HP-1	12SAJ-1P	14007P	12HP-1K

Replacement Components	Unittool Ref. No.	UniPunch Part No.
Punch Head	HPH-107	2075
Round Punch	HP-122	2111
Round Punch with Head	HPA-102A	2011
Shaped Punch with Head	HPA-102K	2016
Stripping Spring	HSS-105	2045
Punch Retainer	PR-100	2180
Round Guide	HG-104	2030
Shaped Guide	HG-104K	2035
Lifter Spring	HLS-106	2070
Round Die	HD-123	2120
Shaped Die	HD-123K	2125
Die Adapter	HDA-108	14072
Shaped Die Adapter	HDA-108K	14074
Round Pedestal Die	HPD-123	2121
Shaped Pedestal Die	HPD-123K	2126
Guide Retainer	GR-300	1002
Guide Retainer Screw	—	91130
Pilot Pin (round)	PP-1200	1120
Pilot Pin (diamond)	PP-1000K	1101

For additional components and specifications - ref. AJ-1 catalog page 30

SPEED WITHIN REACH

UNIPUNCH

AJ-1¼ Unit Interchangeable with HA-1¼ / HP-1¼

SPECIFICATIONS:

MAX. PUNCH DIA.: .4375" (11.11mm) MIN. PUNCH DIA.: .0937" (2.38mm)

MAX. SQUARE: .309" (7.85mm) MIN. SHAPE DIM.: .0937" (2.38mm)

COMPLETE ROUND UNITS		
Model No.	Part No.	Unittool Ref.
4AJ-1¼A	14100A	4HA-1¼
8AJ-1¼A	14101A	8HA-1¼
12AJ-1¼A	14102A	12HA-1¼

COMPLETE SHAPED UNITS		
Model No.	Part No.	Unittool Ref.
4SAJ-1¼A	14105A	4HA-1¼K
8SAJ-1¼A	14106A	8HA-1¼K
12SAJ-1¼A	14107A	12HA-1¼K

OPTIONAL UNIT (Complete With Punch & Pedestal Die)					
COMPLETE ROUND UNITS			COMPLETE SHAPED UNITS		
Model No.	Part No.	Unittool Ref.	Model No.	Part No.	Unittool Ref.
4AJ-1¼P	14100P	4HP-1¼	4SAJ-1¼P	14105P	4HP-1¼K
8AJ-1¼P	14101P	8HP-1¼	8SAJ-1¼P	14106P	8HP-1¼K
12AJ-1¼P	14102P	12HP-1¼	12SAJ-1¼P	14107P	12HP-1¼K

Replacement Components	Unittool Ref. No.	UniPunch Part No.
Punch Head	HPH-127	2171
Round Punch	HP-122	2111
Round Punch with Head	HPA-122A	2110
Shaped Punch with Head	HPA-122K	2115
Stripping Spring	HSS-125	2140
Punch Retainer	PR-100	2180
Round Guide	HG-124	2130
Shaped Guide	HG-124K	2135
Lifter Spring	HLS-126	2170
Round Die	HD-123	2120
Shaped Die	HD-123K	2125
Die Adapter	HDA-128	14172
Shaped Die Adapter	HDA-128K	14174
Round Pedestal Die	HPD-123	2121
Shaped Pedestal Die	HPD-123K	2126
Guide Retainer	GR-300	1002
Guide Retainer Screw	—	91130
Pilot Pin (round)	PP-1200	1120
Pilot Pin (diamond)	PP-1000K	1101

For additional components and specifications - ref. AJ-1¼ catalog page 31

AJ-1½ Unit Interchangeable with HA-1½ / HP-1½

SPECIFICATIONS:

MAX. PUNCH DIA.: .6250" (15.86mm) MIN. PUNCH DIA.: .1250" (3.18mm)

MAX. SQUARE: .441" (11.20mm) MIN. SHAPE DIM.: .0937" (2.38mm)

COMPLETE ROUND UNITS		
Model No.	Part No.	Unittool Ref.
4AJ-1½A	14200A	4HA-1½
8AJ-1½A	14201A	8HA-1½
12AJ-1½A	14202A	12HA-1½

COMPLETE SHAPED UNITS		
Model No.	Part No.	Unittool Ref.
4SAJ-1½A	14205A	4HA-1½K
8SAJ-1½A	14206A	8HA-1½K
12SAJ-1½A	14207A	12HA-1½K

OPTIONAL UNIT (Complete With Punch & Pedestal Die)					
COMPLETE ROUND UNITS			COMPLETE SHAPED UNITS		
Model No.	Part No.	Unittool Ref.	Model No.	Part No.	Unittool Ref.
4AJ-1½P	14200P	4HP-1½	4SAJ-1½P	14205P	4HP-1½K
8AJ-1½P	14201P	8HP-1½	8SAJ-1½P	14206P	8HP-1½K
12AJ-1½P	14202P	12HP-1½	12SAJ-1½P	14207P	12HP-1½K

Replacement Components	Unittool Ref. No.	UniPunch Part No.
Punch Head	HPH-157	2271
Round Punch	HP-152	2211
Round Punch with Head	HPA-152A	2210
Shaped Punch with Head	HPA-152K	2215
Stripping Spring	HSS-155	2240
Punch Retainer	PR-100	2180
Round Guide	HG-154	2230
Shaped Guide	HG-154K	2235
Lifter Spring	HLS-156	2270
Round Die	HD-153	2220
Shaped Die	HD-153K	2225
Die Adapter	HDA-158	14272
Shaped Die Adapter	HDA-158K	14274
Round Pedestal Die	HPD-153	2221
Shaped Pedestal Die	HPD-153K	2226
Guide Retainer	GR-300	1002
Guide Retainer Screw	—	91130
Pilot Pin (round)	PP-1200	1120
Pilot Pin (diamond)	PP-1000K	1101

For additional components and specifications - ref. AJ-1½ catalog page 32

Interchangeable with Unittool

AJ-2 Unit Interchangeable with HA-2 / HP-2

SPECIFICATIONS:

MAX. PUNCH DIA.: .8750" (22.22mm)	MIN. PUNCH DIA.: .2812" (5.5mm)
MAX. SQUARE: .618" (15.69mm)	MIN. SHAPE DIM.: .1250" (3.17mm)

STANDARD UNITS (Complete With Punch, Die Button & Adapter)

COMPLETE ROUND UNITS			COMPLETE SHAPED UNITS		
Model No.	Part No.	Unittool Ref.	Model No.	Part No.	Unittool Ref.
4AJ-2A	14300A	4HA-2	4SAJ-2A	14305A	4HA-2K
8AJ-2A	14301A	8HA-2	8SAJ-2A	14306A	8HA-2K
12AJ-2A	14302A	12HA-2	12SAJ-2A	14307A	12HA-2K

OPTIONAL UNITS (Complete With Punch and Pedestal Die)

COMPLETE ROUND UNITS			COMPLETE SHAPED UNITS		
Model No.	Part No.	Unittool Ref.	Model No.	Part No.	Unittool Ref.
4SAJ-2P	14300P	4HP-2	4SAJ-2P	14305P	4HP-2K
8SAJ-2P	14301P	8HP-2	8SAJ-2P	14306P	8HP-2K
12SAJ-2P	14302P	12HP-2	12SAJ-2P	14307P	12HP-2K

Replacement Components	Unittool Ref. No.	UniPunch Part No.
Punch Head	HPH-207	2371
Round Punch	HP-202	2311
Round Punch with Head	HPA-202A	2310
Shaped Punch with Head	HPA-202K	2315
Stripping Spring	HSS-205	2340
Punch Retainer	PR-100	2180
Round Guide	HG-204	2330
Shaped Guide	HG-204K	2335
Lifter Spring	HLS-206	2370
Round Die	HD-203	2320-2
Round Die (with collar)	HD-203	2320-1
Shaped Die	HD-203K	2325-2
Shaped Die (with collar)	HD-203K	2325-1
Die Adapter	HDA-208	14372
Shaped Die Adapter	HDA-208K	14374
Round Pedestal Die	HPD-203	2321
Shaped Pedestal Die	HPD-203K	2326
Guide Retainer	GR-300	1002
Guide Retainer Screw	—	91130
Pilot Pin (round)	PP-1200	1120
Pilot Pin (diamond)	PP-1000K	1101

For additional components and specifications - ref. AJ-2 catalog page 33

AJ-2½ Unit Interchangeable with HP-2½

SPECIFICATIONS:

MAX. PUNCH DIA.: 1.250" (31.75mm)	MIN. PUNCH DIA.: .2812" (7.14mm)
MAX. SQUARE: 1.060" (26.92mm)	MIN. SHAPE DIM.: .1250" (3.18mm)

COMPLETE ROUND UNITS

Model No.	Part No.	Unittool Ref.
8AJ-2½P	14401P	8HP-2½
12AJ-2½P	14402P	12HP-2½

COMPLETE SHAPED UNITS

Model No.	Part No.	Unittool Ref.
8SAJ-2½P	14406P	8HP-2½K
12SAJ-2½P	14407P	12HP-2½K

Replacement Components	Unittool Ref. No.	UniPunch Part No.
Punch Screw	PS-259	2485
Punch Driver	HPH-257A	2484
Stripping Spring (set of 10)	HSS-255	2440-10
Spring Guard	SG-250	2442
Round Guide	HG-254	2435
Shaped Guide	HG-254K	2435
Lifter Spring	HLS-256	2470
Round Punch	HP-252	14411
Shaped Punch	HP-252K	14416
Pedestal Die	HPD-253	2422
Shaped Pedestal Die	HPD-253K	2428
Guide Retainer	GR-300	1002
Guide Retainer Screw	—	91130
Pilot Pin (round)	PP-1200	1120
Pilot Pin (diamond)	PP-1000K	1101

For additional components and specifications - ref. AJ-2½ catalog page 34

SPEED WITHIN REACH

UNIPUNCH

AH-2½ Unit Interchangeable with HH-2½

SPECIFICATIONS:

MAX. PUNCH DIA.: 1.0000" (25.40mm) MIN. PUNCH DIA.: .2500" (6.35mm)

MAX. SQUARE: .707" (17.96mm) MIN. SHAPE DIM.: .1250" (3.18mm)

COMPLETE ROUND UNITS		
Model No.	Part No.	Unittool Ref.
8AH-2½	2600	8HH-2½
12AH-2½	2601	12HH-2½

COMPLETE SHAPED UNITS		
Model No.	Part No.	Unittool Ref.
8SAH-2½	2605	8HH-2½K
12SAH-2½	2606	12HH-2½K

Replacement Components	Unittool Ref. No.	UniPunch Part No.
Punch Head	HHPH-257	2671
Punch Screw	N.A.	91025
Round Punch	HHP-252	2611
Round Punch with Head	HHPA-252A	2610
Shaped Punch	HHP-252K	2616
Shaped Punch with Head	HHPA-252K	2615
Punch Plate	HHPP-250	2677
Spring Retainer (set of 2)	HHSR-100	2681-2
Stripper Bolt (spring retainer) (2 req'd)	N.A.	2682
Stripping Spring (set of 2)	HHSS-255	2540-2
Lifter Spring (set of 2)	HHLS-256	2673-2
Stripper Bolt (lifter)	N.A.	2683
Stripper Plate	HHSP-259	2676
Key (punch)	HHPK-100	2778
Punch Retainer	HHPR-100	2680
Round Die	HHD-253	2620
Shaped Die	HHD-253K	2625
Round Die Holder	N.A.	2674
Shaped Die Holder	HHDH-258K	2675
Pilot Pin (round)	PP-1000	1001
Pilot Pin (diamond)	PP-1000K	1101

For additional components and specifications - ref. AH-2½ catalog page 36

AH-3 Unit Interchangeable with HH-3

SPECIFICATIONS:

MAX. PUNCH DIA.: 1.3750" (34.92mm) MIN. PUNCH DIA.: .3750" (9.53mm)

MAX. SQUARE: .972" (24.68mm) MIN. SHAPE DIM.: .1250" (3.18mm)

COMPLETE ROUND UNITS		
Model No.	Part No.	Unittool Ref.
8AH-3	3700	8HH-3
12AH-3	3701	12HH-3

COMPLETE SHAPED UNITS		
Model No.	Part No.	Unittool Ref.
8SAH-3	3705	8HH-3K
12SAH-3	3706	12HH-3K

Replacement Components	Unittool Ref. No.	UniPunch Part No.
Punch Screw	N.A.	91260
Punch Plate	HHPP-307	3772
Punch Driver	HHD-309	3779
Key (punch driver)	HPK-302	3778
Stripping Spring (1"OD x 3"lg) (set of 2)	N.A.	3741-2
Stripping Spring (2"OD x 3"lg) (set of 2)	HHSS-305	3740-2
Spring Spacer (2 req'd)	N.A.	3742
Stripper Bolt (4 req'd)	N.A.	3784
Lifter Spring (set of 4)	HHLS-306	3774-4
Stripper Plate	HHSP-308	3773
Round Punch	HHP-302	2513
Shaped Punch	HHP-302K	2519
Round Die	HHD-303	2524
Shaped Die	HHD-303K	2529
Die Key	HHDK-303-1	3777
Pilot Pin (round)	PP-1000	1001
Pilot Pin (diamond)	PP-1000K	1101

For additional components and specifications - ref. AH-3 catalog page 37

Interchangeable with
Unittool

AH-3½ Unit Interchangeable with HH-3½

SPECIFICATIONS:

MAX. PUNCH DIA.: 2.000" (50.80mm)

MAX. SQUARE: 1.414" (35.9mm)

MIN. PUNCH DIA.: .5000" (12.7mm)

MIN. SHAPE DIM.: .1250" (3.18mm)

COMPLETE ROUND UNITS		
Model No.	Part No.	Unittool Ref.
8AH-3½	2500	8HH-3½
12AH-3½	2501	12HH-3½

COMPLETE SHAPED UNITS		
Model No.	Part No.	Unittool Ref.
8SAH-3½	2505	8HH-3½K
12SAH-3½	2506	12HH-3½K

Replacement Components	Unittool Ref. No.	UniPunch Part No.
Punch Screw	N.A.	91072
Round Punch Driver	N.A.	2582
Shaped Punch Driver	HHPD-354K	2583
Round Punch	HHP-352	2511
Shaped Punch	HHP-352K	2515
Punch Plate	HHPP-350	2572
Spring Retainer (set of 2)	HHSR-100	2681-2
Stripper Bolt (spring retainer) (2 req'd)	N.A.	2682
Stripping Spring (set of 2)	HHSS-255	2540-2
Lifter Spring (set of 2)	HHLS-256	2673-2
Stripper Bolt (lifter) (2 req'd)	N.A.	2683
Stripper Plate	HHSP-359	2573
Key (driver)	HHPK-100	2778
Punch Retainer	HHPR-100	2680
Round Die	HHD-353	2520
Shaped Die	HHD-353K	2525
Pilot Pin (round)	PP-1000	1001
Pilot Pin (diamond)	PP-1000K	1101

For additional components and specifications - ref. AH-3½ catalog page 38

AH-6 Unit Interchangeable with HH-5½

SPECIFICATIONS:

MAX. PUNCH DIA.: 3.000" (76.2mm)

MAX. SQUARE: 2.121" (53.87mm)

MIN. PUNCH DIA.: 1.000" (25.4mm)

MIN. SHAPE DIM.: .1875" (4.76mm)

COMPLETE ROUND UNITS		
Model No.	Part No.	Unittool Ref.
8AH-6	2700	8HH-5½
12AH-6	2701	12HH-5½

COMPLETE SHAPED UNITS		
Model No.	Part No.	Unittool Ref.
8SAH-6	2706	8HH-5½K
12SAH-6	2707	12HH-5½K

Replacement Components	Unittool Ref. No.	UniPunch Part No.
Punch Screw	N.A.	91072
Punch Driver	HHPD-554K	2779
Round Punch	HHP-552	2512
Shaped Punch	HHP-552K	2516
Punch Plate	HHPP-550	2772
Spring Retainer (set of 4)	HHSR-100	2681-4
Stripper Bolt (spring retainer) (4 req'd)	N.A.	2684
Stripping Spring (set of 4)	HHSS-255	2540-4
Lifter Spring (set of 2)	HHLS-256	2673-2
Stripper Bolt (lifter) (2 req'd)	N.A.	2685
Stripper Plate	HHSP-559	2773
Key (driver)	HHPK-100	2778
Punch Retainer	HHPR-100	2680
Round Die	HHD-553	3820
Shaped Die	HHD-553K	3825
Pilot Pin (round)	PP-1000	1001
Pilot Pin (diamond)	PP-1000K	1101

For additional components and specifications - ref. AH-6 catalog page 39

REPL. TOOLING

BX-3/4 Unit Interchangeable with M-3/4

SPECIFICATIONS:

MAX. PUNCH DIA.: .3125" (7.93mm)	MIN. PUNCH DIA.: .0937" (2.38mm)
MAX. SQUARE: N.A.	MIN. SHAPE DIM.: N.A.

COMPLETE ROUND UNITS

Model No.	Part No.	Unittool Ref.
4BX-3/4	3000	4M-3/4
8BX-3/4	3001	8M-3/4

Replacement Components	Unittool Ref. No.	UniPunch Part No.
Stripper Bolt (2 req'd)	MSB-078	3033
Retainer Plate	MR-079	3032
Punch Screw	N.A.	91203
Punch Head	MPH-077	3171
Round Punch	MP-072	3111
Round Punch with Head	MPA-072A	3110
Stripping Spring	MSS-075	3040
Guide	MG-074	3030
Lifter Spring	MLS-076	4273
Die (.490" O.D.)	MD-073	3121
Pilot Pin (round)	PP-1000	1001

For additional components and specifications - ref. BX-3/4 catalog page 55.

Tooling For M-1 Unit

SPECIFICATIONS:

MAX. PUNCH DIA.: .3125" (9.52mm)	MIN. PUNCH DIA.: .0937" (2.38mm)
MAX. SQUARE: N.A.	MIN. SHAPE DIM.: N.A.

**Note: No Interchangeable Units are available
Replacement Punches & Dies are listed to right**

Replacement Components	Unittool Ref. No.	UniPunch Part No.
Punch Screw	N.A.	91203
Punch Head	MPH-107	3271
Round Punch	MP-122	3211
Round Punch with Head	MPA-102A	3210
Die (.688" O.D.)	MD-103	3221
Pilot Pin (round)	PP-1000	1001

Tooling For M-1 1/4 Unit

SPECIFICATIONS:

MAX. PUNCH DIA.: .3750" (9.52mm)	MIN. PUNCH DIA.: .0937" (2.38mm)
MAX. SQUARE: .265" (6.73mm)	MIN. SHAPE DIM.: .0937" (2.38mm)

**Note: No Interchangeable Units are available
See UniPunch B-1 1/4 catalog page for compatible
complete punching units. See page 57**

Replacement Components	Unittool Ref. No.	UniPunch Part No.
Punch Retainer	MPR-128	3372
Punch Screw	N.A.	91203
Punch Head	MPH-127	3371
Round Punch	MP-122	3211
Round Punch w/ Head	MPA-122A	3310
Shaped Punch	MP-122K	3316
Shaped Punch w/ Head	MPA-122K	3315
Round Stripping Guide w/ Open Stripper	MG-124	3323
Shaped Stripping Guide w/ Open Stripper	MG-124K	3324
Round Die (15/16" O.D.)	MD-123	3321
Shaped Die (15/16" O.D.)	MD-123K	3326
Guide Retainer	N.A.	1080
Guide Retainer Screw (2 req'd)	N.A.	91123
Pilot Pin (round)	PP-1000	1001
Pilot Pin (diamond)	PP-1000K	1101

Interchangeable with

Unittool

Tooling for M-1³/₄

SPECIFICATIONS:

MAX. PUNCH DIA.: .5000" (12.70mm)	MIN. PUNCH DIA.: .1250" (3.18mm)
MAX. SQUARE: .353" (8.96mm)	MIN. SHAPE DIM.: .0937" (2.38mm)

Note: No Interchangeable Units are available
See UniPunch B-1³/₄ catalog page for compatible complete punching units. See Page 58

Replacement Components	Unittool Ref. No.	UniPunch Part No.
Punch Retainer	MPR-178	3472
Punch Screw	N.A.	91230
Punch Head	MPH-177	3471
Round Punch	MP-172	3411
Round Punch w/ Head	MPA-172A	3410
Shaped Punch	MP-172K	3416
Shaped Punch w/ Head	MPA-172K	3415
Round Stripping Guide w/ Open Stripper	MG-174	3423
Shaped Stripping Guide w/ Open Stripper	MG-174K	3427
Round Die (1" O.D.)	MD-173	3421
Shaped Die (1" O.D.)	MD-173K	3426
Guide Retainer	N.A.	7664
Guide Retainer Screw (2 req'd)	N.A.	91123
Pilot Pin (round)	PP-1000	1001
Pilot Pin (diamond)	PP-1000K	1101

Tooling for M-2¹/₄

SPECIFICATIONS:

MAX. PUNCH DIA.: 1.000" (25.40mm)	MIN. PUNCH DIA.: .2500" (6.35mm)
MAX. SQUARE: .707" (17.96mm)	MIN. SHAPE DIM.: .0937" (2.38mm)

Note: No Interchangeable Units are available
See UniPunch BX-2¹/₄ catalog page for compatible complete punching units. See Page 59

Replacement Components	Unittool Ref. No.	UniPunch Part No.
Punch Retainer	MPR-228	3572
Punch Screw	N.A.	91250
Punch Head	MPH-227	3571
Round Punch	MP-222	3511
Round Punch w/ Head	MPA-222A	3510
Shaped Punch	MP-222K	3516
Shaped Punch w/ Head	MPA-222K	3515
Round Stripping Guide	MG-224	3530
Shaped Stripping Guide	MG-224K	3535
Round Die (1 5/8" O.D.)	MD-223	3521
Shaped Die (1 5/8" O.D.)	MD-223K	3526
Guide Retainer	MGR-300	1030
Guide Retainer Screw	N.A.	91220
Pilot Pin (round)	PP-1000	1001
Pilot Pin (diamond)	PP-1000K	1101

Tooling For M-2¹/₂ Unit

SPECIFICATIONS:

MAX. PUNCH DIA.: 1.5000" (38.10mm)	MIN. PUNCH DIA.: .5000" (12.70mm)
MAX. SQUARE: 1.060" (26.92mm)	MIN. SHAPE DIM.: .1250" (3.18mm)

Note: No Interchangeable Units are available
Replacement Punches & Dies are listed to right.

Replacement Components	Unittool Ref. No.	UniPunch Part No.
Round Punch	MP-252	3610-2
Shaped Punch	MP-252K	57859
Round Die	MD-253	2420
Shaped Die	MD-253K	2425
Pilot Pin (round)	PP-1000	1001
Pilot Pin (diamond)	PP-1000K	1101

REPL. TOOLING

B-3 Unit Interchangeable with M-3

SPECIFICATIONS:

MAX. PUNCH DIA.: 2.000" (50.80mm) MIN. PUNCH DIA.: .5000" (12.70mm)

MAX. SQUARE: 1.414" (35.91mm) MIN. SHAPE DIM.: .1250" (3.18mm)

COMPLETE ROUND UNITS		
Model No.	Part No.	Unittool Ref.
8B-3	3600	8M-3
12B-3	3601	12M-3

COMPLETE SHAPED UNITS		
Model No.	Part No.	Unittool Ref.
8SB-3	3606	8M-3K
12SB-3	3607	12M-3K

Replacement Components	Unittool Ref. No.	UniPunch Part No.
Punch Screw	N.A.	91240
Punch Head	MPH-307	3671
Lifter Spring	MLS-306	3670
Stripper Spring (6 req'd)	MSS-305	3640
Round Guide	N.A.	3675
Shaped Guide	MG-304K	3675
Punch Driver	MPD-308	3611
Round Punch Tip (over 1.124")	MP-302	3610-1
Round Punch Tip (under 1.125")	MP-302-1	3610-2
Shaped Punch	MP-302K	3615
Round Die	HD-303	3620
Shaped Die	HD-303K	3625
Guide Retainer	MGR-300	1030
Guide Retainer Screw	N.A.	91220
Pilot Pin (round)	PP-1000	1001
Pilot Pin (diamond)	PP-1000K	1101

For additional components and specifications - ref. B-3 catalog page 60

B-5 Unit Interchangeable with M-5

SPECIFICATIONS:

MAX. PUNCH DIA.: 3.5000" (88.90mm) MIN. PUNCH DIA.: 1.0000" (25.40mm)

MAX. SQUARE: 2.474" (62.84mm) MIN. SHAPE DIM.: .1250" (3.18mm)

COMPLETE ROUND UNITS		
Model No.	Part No.	Unittool Ref.
8B-5	3800	8M-5
12B-5	3801	12M-5

COMPLETE SHAPED UNITS		
Model No.	Part No.	Unittool Ref.
8SB-5	3805	8M-5K
12SB-5	3806	12M-5K

Replacement Components	Unittool Ref. No.	UniPunch Part No.
Punch Screw	N.A.	91152
Punch Head	MPP-507	3873
Lifter Spring (4 req'd)	MLS-506	3870
Stripper Spring (12 req'd)	MSS-305	3840
Shaped Guide	MG-504K	3881
Punch Sleeve	MPD-508	3871
Locator	PR-500	3880
Round Punch	MP-502	3810
Shaped Punch	UMP-502K	3815
Round Die	HD-603	3820
Shaped Die	HD-603K	3825
Guide Retainer	MGR-300	1030
Guide Retainer Screw	N.A.	91220
Pilot Pin (round)	PP-1000	1001
Pilot Pin (diamond)	PP-1000K	1101

For additional components and specifications - ref. B-5 catalog page 61

Tooling for M-8 Unit

Not Available

M-Series Corner Notch Units Interchangeable with B-Series

5" x 5"		
Replacement Components	Unittool Ref. No.	UniPunch Part No.
Left Hand Corner Notch	M-55-LCN	7010
Right Hand Corner Notch	M-55-RCN	7020

3" x 3"		
Replacement Components	Unittool Ref. No.	UniPunch Part No.
Left Hand Corner Notch	M-33-LCN	7040
Right Hand Corner Notch	M-33-RCN	7050

For additional components and specifications - ref. B-Series Corner Notch page 62

Note: Post Design Corner Notch Units are not available

Glossary

A-2 Tool Steel: All “A” and “B” Series punches use A-2 5% chrome air hardening tool steel. Compared to oil hardened tool steel, this premium tool steel provides longer tool life and better resistance to chipping and cracking.

Angle Settings: Most UniPunch shaped tools can be used in two positions. Standard keying is typically 0 & 90 degrees. Other angular settings are available upon request. See page 91.

Blanking: Blanking is the process of cutting a desired shape out of a flat piece of sheet metal. The punched slug is the finished product. For blanking the punch has no shear and the die size determines the actual blank size.

Burr: The rough edge that protrudes on the bottom side of a hole after punching.

Chisel Shear: An angle on the punch face for the purpose of reducing tonnage required.

Cluster: A grouping of holes.

Coping: The process of trimming or notching the end of tubing (or pipe) to fit against another piece of tubing, for example for welding joints.

Countersink: A conical hole in sheet metal to accept a flathead screw or other fastener.

Die: The tool that supports the sheet metal as the punch penetrates through it.

Die Block: The device that clamps the die into the UniPunch C-frame holder.

Die Clearance: This is the space between the cutting edge of the punch and the cutting edge of the die. Optimal die clearance is determined by the thickness and type of material being punched. See page 97.

Die Height: The distance from the bottom of the holder to the top die surface.

Emboss: A raised or sunken form in sheet metal made without cutting the material.

Extrusion: A forming operation forcing the material into a larger die hole; for example, to accept self-tapping screws.

Feed Clearance: The opening above the die surface through which the work piece is inserted when the UniPunch unit is in the open position.

Gauge: (1) A work stop or pin locating device for positioning the material within the UniPunch system. (2) A system of measurement that defines the thickness of sheet metal.

Galling: Metal deposits that build up on punch tips or on the inner diameters of guides.

Guide/Guide Assembly: The sleeve that supports the punch and its components within the holder. Guides also serve to hold the material in place while the punch is being stripped from the material.

Heeled Punch: A punch with a heel that engages the die before the cutting edges contact the work piece. Primarily used for edge notching.

Holder: In the UniPunch system, the component that houses the punch, die, guide and/or related components that make up a complete unit.

Inside Diameter (ID): The diameter on the inside of an object, *e.g.* a tube or pipe.

Key: The device used to locate and position tooling within the holder. An example would be the external pin found on most UniPunch shaped punches.

Keyhole: A shaped hole commonly used to facilitate part assembly. See page 91.

Knockout: The result of cutting and forming material so the slug is held to the material by tabs. Commonly used in electrical panels and boxes. See page 93.

Lance and Form: Slitting and forming a pocket opening in the part. See page 92.

Louver: A slit cut and formed in material; for example, air vent openings.

Modular Tooling: A system of tooling assembled from standard, reusable components. UniPunch modular tooling includes units for punching and/or notching, components for part gauging, and press mounting equipment for working with flat or formed material, structural shapes, extrusions, tubing and pipe.

Mounting Systems: Bases for holding UniPunch tooling and gauges within a punch press or press brake.

Multicyl: An air over oil cylinder used as an alternate power source to actuate UniPunch tooling in lieu of a press or press brake.

Notching: The process of cutting two or more sides; for example, from the edge of sheet metal or angle.

Outside Diameter (OD): The distance across the outside of an object; for example, tubing or pipe.

Pinot Pin: The locating device found at the base of UniPunch tooling for positioning the unit to a template or unispacer.

Punch: The tool that goes through the material to make a hole.

Radius Corner: (1) The sharp corner(s) on the punch or die that have been rounded. See page 99. (2) The corner of a work piece that has been trimmed to form the arc of a circle. See page 92.

Shim: A thin metal spacer assembled into a UniPunch unit to extend the punch length or die height after sharpening.

Shut Height: The total height from the bottom of the holder to the top of the punch with the UniPunch unit in the normal closed position. See unit pages for individual operating specifications.

Slug: The material removed to create the hole or notch. The slug is usually scrap. In blanking the slug is the desired part.

Stripper Plate: A metal plate designed to surround the punch to assist in parting the punch from the material.

Stripping: The process of removing the punch from the material.

Template: A locating plate for positioning UniPunch units according to the requirements of the part being punched.

Tonnage: The force required for punching and/or notching material.

Tube Mandrel: A support on the inside of a tube used in punching holes in tube or pipe that prevents dimpling and part deformation.

Unit: The term used for the completely assembled self-contained punching device.

UNIPUNCH PRODUCTS, INC. TERMS AND CONDITIONS OF SALE

1. Offer, Governing Provisions and Cancellation. Any agreement between UniPunch Products, Inc. ("UniPunch") and a buyer for the sale of goods and/or services described in a UniPunch Quotation or UniPunch Order Acknowledgement will be in accordance with these terms and conditions. A UniPunch Quotation is an offer, and a UniPunch Order Acknowledgement is an offer or counter-offer by UniPunch to sell the goods and/or services described thereon and such documents are not an acceptance of any offer made by a buyer and are expressly conditioned on buyer's assent to these Terms and Conditions of Sale. UniPunch objects to any additional or different terms contained in any purchase order or other communication previously or hereafter provided by buyer to UniPunch. No such additional or different terms or conditions will be of any force or effect. The terms contained in or incorporated into a UniPunch Quotation or UniPunch Order Acknowledgement will be the entire agreement between UniPunch and buyer on the subject of the transaction described thereon; and there are no conditions to that agreement that are not so contained or incorporated. **THE OFFER BY UNIPUNCH AND THE RESULTANT AGREEMENT SHALL BE GOVERNED BY AND CONSTRUED ACCORDING TO THE LAWS OF THE STATE OF WISCONSIN AND THE U.S. (WITHOUT REFERENCE TO PRINCIPLES OF CONFLICTS OF LAWS). THE RIGHTS AND OBLIGATIONS OF THE PARTIES SHALL NOT BE GOVERNED BY THE 1980 U.N. CONVENTION ON CONTRACTS FOR THE INTERNATIONAL SALE OF GOODS.**

No accepted offer may be cancelled or altered by buyer except upon terms and conditions accepted by UniPunch in writing; and no changes will be binding unless set forth in writing and manually signed by UniPunch. An offer by UniPunch may be revoked by UniPunch at any time before it is accepted by buyer, and shall automatically expire 45 calendar days after its date if buyer has not accepted it before then. Neither buyer's acceptance of an offer nor any conduct by UniPunch (including but not limited to shipment of goods) shall oblige UniPunch to sell to buyer any quantity of goods in excess of the quantity that buyer has committed to purchase from UniPunch at the time of such acceptance or conduct.

2. Credit Approval; Payment Terms. All payment terms set forth in this document are subject to UniPunch's approval of buyer's credit, in UniPunch's discretion; and if such approval is withheld, payment shall be due in advance of UniPunch's performance. Except as otherwise provided on the face of a UniPunch Quotation or UniPunch Order Acknowledgement or in the preceding sentence, payment is due upon buyer's receipt of UniPunch's invoice following shipment. Interest will be charged at the lesser of (i) 18% per year, or (ii) the highest rate permitted by applicable law, on accounts more than 30 calendar days past due. If production or shipment of completed goods, or other UniPunch performance, is delayed by buyer, UniPunch may immediately invoice, and buyer shall pay, the percentage of the purchase price corresponding to the percentage of completion; in addition, buyer shall compensate UniPunch for storage of completed goods or work in process during any such delay, whether stored at UniPunch's facility or an independent storage company's facilities.

3. Taxes and Other Charges. Any manufacturer's tax, occupation tax, use tax, sales tax, excise tax, value added tax, duty, custom, inspection or testing fee, or any other tax, fee, interest or charge of any nature whatsoever imposed by any governmental authority on or measured by the transaction between UniPunch and buyer shall be paid by buyer in addition to the prices quoted or invoiced. In the event UniPunch is required to pay any such taxes or other charges, buyer shall reimburse UniPunch therefor on demand.

4. Delivery, Claims and Force Majeure. Unless otherwise provided on the face of a UniPunch Quotation or UniPunch Order Acknowledgement, goods shall be delivered to buyer F.O.B. UniPunch's loading dock or, for ultimate destinations outside of the U.S., ex works UniPunch's loading dock (as the latter shipping term is defined in Incoterms 2010). Delivery of products to the carrier shall constitute delivery to buyer; and regardless of shipping terms or freight payment, buyer shall bear all risk of loss or damage in transit. UniPunch reserves the right to make delivery in installments; all such installments to be separately invoiced and paid for when due in accordance with their respective invoice, without regard to subsequent deliveries. Delay in delivery of any installment shall not relieve buyer of its obligations to accept remaining deliveries.

Claims for shortages or other errors in delivery must be made in writing to UniPunch within 10 calendar days after receipt of shipment; and failure to give such notice shall constitute unqualified acceptance and a waiver of all such claims by buyer. Claims for loss of or damage to goods in transit must be made to the carrier, and not to UniPunch.

All delivery dates are approximate. UniPunch shall not be liable for any losses or damages as a result of any delay or failure to deliver due to any cause beyond UniPunch's reasonable control, including but not limited to any act of God, act of buyer, embargo or other governmental act, regulation or request, fire, accident, strike, slowdown, war, act of terrorism, riot, delay in transportation, or inability to obtain necessary labor, materials or manufacturing facilities. In the event of any such delay, the date of delivery shall be extended for a period equal to the time lost because of the delay. Buyer's exclusive remedy for other delays and for UniPunch's inability to deliver for any reason shall be rescission of its agreement to purchase.

5. Changes. UniPunch may at any time make such changes in design and construction of products, components or parts as UniPunch deems appropriate, without notice to buyer. UniPunch may furnish suitable substitutes for materials unobtainable because of priorities or regulations established by governmental authority or nonavailability of materials from suppliers.

6. UniPunch's Limited Warranty. UniPunch's Limited Warranty is as follows:

- a. Basic Limited Warranty Coverage. UniPunch Products, Inc. ("UniPunch") warrants that it will repair or, at its option, replace any parts manufactured by UniPunch and found to be defective in factory material or workmanship within a period of 30 days after delivery to the original purchaser.
- b. UniPunch's Obligations. UniPunch will at its expense repair or, at its option, replace F.O.B. UniPunch's loading dock or, for customers outside the United States, ex works UniPunch's loading dock (as the latter shipping term is defined in Incoterms 2010) any parts manufactured by it and found to be defective in material or workmanship during the applicable warranty period, provided

that the owner of the warranted goods complies with the "Warranty Claims Procedure" set forth below. The owner of the warranted goods will be responsible for the expense of returning any parts to UniPunch for warranty evaluation. UniPunch will at its expense return any part repaired or replaced under this warranty to the owner of the warranted goods, by truck, United Parcel Service or U.S. Mail, at UniPunch's option. The owner of the warranted goods will be responsible for the cost of any other method of shipment including air freight.

c. **Items Not Covered.** UniPunch's limited warranty does not cover:

- i. a mechanic's travel time;
- ii. the cost of removal of defective parts and reinstallation of repaired or replacement parts;
- iii. used goods, unless specifically covered by a separate written warranty;
- iv. component parts manufactured by others, including, but not limited to springs and hydro-pneumatic actuators, (but, if new, such items are ordinarily warranted by the manufacturer thereof);
- v. depreciation or damage caused by normal wear and tear, accident, abuse, improper maintenance, abnormal use, use other than in accordance with UniPunch's instruction, or improper protection in storage,
- vi. goods which have been modified or altered other than with the prior written approval of UniPunch; or
- vii. the cost of normal maintenance or service, including but not limited to the cost of lubrication, and replacement of consumable components such as punches, dies, springs, and guides; the cost of repairing or replacing other property which is damaged when the goods do not work properly.

d. **Warranty Claims Procedure.** Within five (5) days of the expiration of the applicable warranty period, the owner of any warranted item claimed to be defective must:

- i. notify UniPunch immediately upon discovery of any defect covered by this warranty;
- ii. provide UniPunch documentary evidence of the date of delivery of the item to the original purchaser; and
- iii. if requested by UniPunch, ship the defective part(s) to UniPunch, freight (and duty if any) prepaid, for inspection.

e. **No Other Warranties.** UniPunch makes no warranty other than that set forth above, express or implied. None of UniPunch's representatives is authorized to make any representation or warranty on UniPunch's behalf or in its name. UniPunch's only obligation and its customer's only remedies, in connection with the sale of UniPunch products, are those set forth in this Warranty.

THIS WARRANTY IS EXCLUSIVE AND IN LIEU OF ALL OTHER REPRESENTATIONS AND WARRANTIES, EXPRESS OR IMPLIED; AND UNIPUNCH EXPRESSLY DISCLAIMS AND EXCLUDES ANY IMPLIED WARRANTY OF MERCHANTABILITY OR FITNESS FOR ANY PARTICULAR PURPOSE, AND ANY WARRANTIES ARISING FROM COURSE OF DEALING OR USAGE OF TRADE.

7. Patents, Trademarks and Copyrights. **UNIPUNCH GIVES NO WARRANTY THAT THE PRODUCTS SOLD WILL BE DELIVERED FREE OF THE RIGHTFUL CLAIM OF ANY THIRD PARTY FOR INFRINGEMENT OF ANY PATENT, COPYRIGHT OR TRADEMARK OR ANY OTHER PROPRIETARY RIGHTS.**

8. Consequential Damages and Other Liability; Indemnity. **IN NO EVENT SHALL UNIPUNCH BE RESPONSIBLE FOR ANY OTHER OBLIGATIONS OR LIABILITIES OR ANY CONSEQUENTIAL OR INCIDENTAL DAMAGES, INCLUDING BUT NOT LIMITED TO DAMAGES FOR LOSS OF PRODUCTION, LOSS OF PROFITS, OR RENTAL OF SUBSTITUTE EQUIPMENT, WHETHER ARISING OUT OF BREACH OF WARRANTY OR OTHER BREACH OF CONTRACT, NEGLIGENCE OR OTHER TORT, OR ON ANY STRICT LIABILITY THEORY OR UNDER OTHER THEORIES OF LAW OR EQUITY, WITH RESPECT TO GOODS OR SERVICES SOLD BY UNIPUNCH, OR ANY UNDERTAKINGS, ACTS OR OMISSIONS RELATING THERETO.** Without limiting the generality of the foregoing, UniPunch specifically disclaims any liability for property damages, penalties, special or punitive damages, damages for lost profits or revenues, down-time, lost goodwill, cost of capital, cost of substitute goods or services, or for any other types of economic loss, or for claims of buyer's customers or any third party for any such damages, costs or losses. **UNIPUNCH SHALL NOT BE LIABLE FOR AND DISCLAIMS ALL CONSEQUENTIAL, INCIDENTAL, INDIRECT AND CONTINGENT DAMAGES WHATSOEVER.** UniPunch's liability with respect to the goods or services sold hereunder shall be limited to the warranty provided in section 6 of these Terms and Conditions of Sale and, with respect to any other breaches of its contract with buyer, shall be limited to the contract price.

Buyer shall indemnify and hold harmless UniPunch from and against any and all losses, liabilities, damages and expenses (including but not limited to attorneys' fees and other costs of defense) that UniPunch may incur as a result of any claim by buyer or by buyer's customers or by any third party arising out of or in connection with the goods or services sold hereunder, including but not limited to any such claim based upon the negligence of UniPunch in designing, manufacturing, performing and/or selling such goods or services, unless such losses, liabilities, damages or expenses are ultimately determined to be attributable solely to the willful misconduct of UniPunch.

9. Technical Information. Buyer agrees any sketches, models or samples submitted by UniPunch and any designs developed in fulfillment of Buyer's order shall remain the property of UniPunch, and shall be treated as confidential information unless UniPunch has in writing indicated a contrary intent. Buyer agrees not to use or disclose such sketches, models or samples, or any design or production techniques revealed thereby, without the express, prior written consent of UniPunch.

10. Tools. Any dies, jigs or tools that UniPunch manufactures or acquires in connection with its performance under a UniPunch Quotation or UniPunch Order Acknowledgement shall remain the property of UniPunch, notwithstanding any charges to buyer therefor. Any such charges convey to buyer the right to have the tools, dies or jigs used by UniPunch for performance of UniPunch's agreement with buyer, but do not convey title or right of possession or any other right.