

OVER 1,000,000 PRODUCTS ONLINE!

 **GLOBAL**[®]
globalindustrial.com

INDEX
P. ii

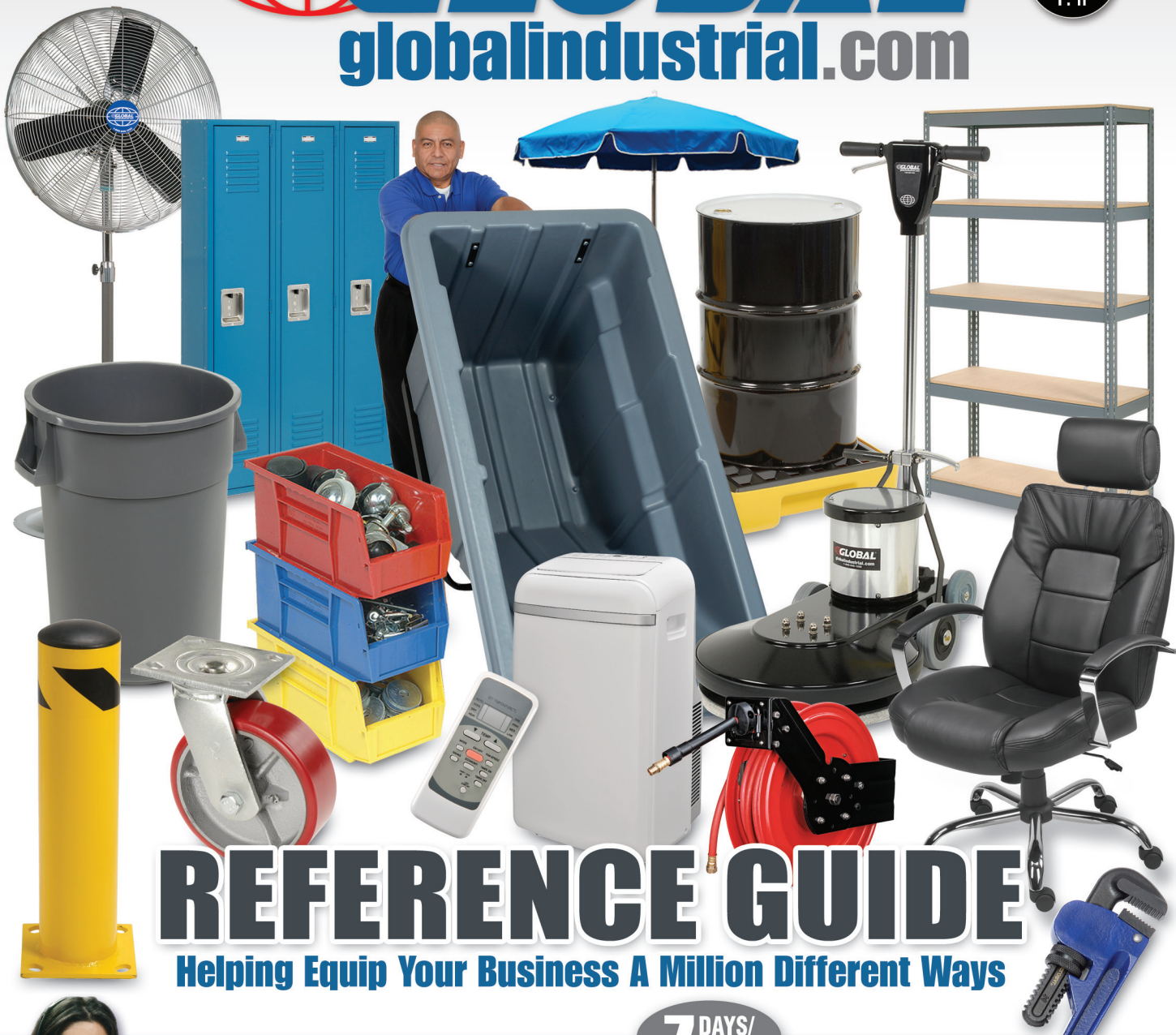

REFERENCE GUIDE

Helping Equip Your Business A Million Different Ways

7 DAYS/
WEEK

CALL TODAY

01-800-467-0529

NEW Deals Every Day!
Visit Our Website
chproductos.com



You Can Count On Global Industrial

For over 60 years, Global Industrial has been a leader in quality industrial products in North America and Europe. We strive to offer you fast, convenient shopping, prompt order fulfillment, friendly and thorough customer service and an extensive selection of industrial products.

Our big volume purchases, direct from the source give us total control over quality and price. And if we can't find it, we make it to meet our high standards and save you money.

Count on Global to continue to bring you Industrial Quality Products, Quality Assured by Field Experts and packed with Extra Features at the lowest possible price. Keep this digital catalog on your desktop as a source for everything you need.

Sincerely,



Richard Leeds
CEO



Countries Served

Mexico
Puerto Rico
El Salvador
Curacao
Chile
Dominican Republic

Colombia
Canada
Aruba
Bahamas
Bermuda
Haiti

Honduras
Panama
Virgin Island
UK
Costa Rica
Brazil

Quick Index

Bins & Containers.....	2-11	Security & Crowd Control.....	90-92
Shelving & Racks.....	12-42	HVAC/Fans	92-97
Lockers & Partitions	43-49	Drum Handling.....	98-99
Cabinets.....	50-54	Packaging & Shipping	100
Pallet & Lift Trucks.....	55-59	Office Furniture	101-145
Trucks, Carts & Casters.....	59-79	Tools.....	146-147
Janitorial & Maintenance.....	79-86	Workbench & Shop Desks	148-163
Conveyors & Dock Equipment.....	87-89		

QUICK
SHIP

BEST
PRICES

EXPERT
INFO

CUSTOMER
SERVICE



GLOBAL[®]
globalindustrial.com

INDUSTRIAL
GRADE

IN
STOCK

SPECIAL
QUOTES

Call Us Today

01-800-467-0529

email: Internationalsales@globalindustrial.com

www.chproductos.com



LIMITATION OF LIABILITY: In no event shall Global or any of its subsidiaries or affiliates be liable for any indirect, special, incidental or consequential damages including but not limited to loss of use, loss of data, loss of business or profits. Some states do not allow the exclusion or limitation of incidental or consequential damages, so the above limitation or exclusion may not apply to you. All product prices, specifications and availability are subject to change without notice. Global Industrial Equipment is not responsible for errors in typography and photography. Because of continuing improvements, actual product may differ slightly from photo. Photograph images may have been retouched. All leather seating is a combination of genuine leather inside seat and back with outside and sides in durable matching vinyl. Some items may not comply with California Proposition 65.

RETURN POLICY: If you are not satisfied with a product, contact us within 30 days of receipt. A refund will be arranged excluding freight charges upon inspection. Custom-cut, custom built or special items such as matting, slings, cranes, prefab offices, buildings, mezzanines, assembled lockers and regularly stocked items such as generators, pressure washers, water and trash pumps, snow throwers, radio headsets, stripping paint, line strippers, floor care machines, vacuums, custom fabric chairs, forklifts and more are excluded. Returned merchandise must be shipped in original packaging, freight prepaid, unused, and in resalable condition and are subject to 15% restocking fee. **BEFORE** returning product, call 1800 645-2866 for a Return Merchandise Authorization. **Global inspects all returns and reserves the right to refuse credits on damaged, misused or non-resalable items.** For detailed return policies visit our website or email us at service@globalindustrial.com. In addition, orders for custom-cut, custom built or special items are non-cancelable.

WARRANTY LIMITATIONS: A full text version of each limited warranty referenced herein may be obtained by mailing a self addressed, stamped envelope to Global Industrial 2505 Mill Center Parkway, Suite 100, Buford, GA 30518-3700 Attention: Customer Service-Warranty Information (include item number in the request). Except as specifically set forth herein Global makes no warranties, express or implied, and disclaims all other warranties, including without limitation implied warranties of merchantability, fitness for a particular purpose and conformity to models or samples. Some states do not allow limitations on implied warranties so these limitations may not apply to you. The limited warranties set forth herein give you specific legal rights and you may have other rights that vary from state to state.

REBATE TERMS & CONDITIONS: Offer good only on purchases from Global Equipment Co. See individual item for valid rebate dates. You must submit rebate form with the original invoice and UPC product label from carton. If the UPC is not available, please include the original packing list.

The name and address of the party applying for the rebate must be the same as the bill to name and address appearing on the invoice. Photocopies are not acceptable. All requests must be postmarked no later than 30 days from original invoice to qualify. All others will be denied. Global Equipment Co. is not responsible for lost or misdirected mail. Offer is valid only for end-user purchases and is not available to Global Equipment Co. employees, agencies, distributors or resellers. Your rebate rights cannot be assigned or transferred, and selling or trading proof of purchase is prohibited. Offer may not be combinable with any other offers and discounts available from Global Equipment Co. Offer good in US only. Rebate paid in US dollars. See individual item for rebate limits. Requests from P.O. Boxes not accepted. Requests with invalid or undeliverable e-mail address will be denied. This offer may not be published in any refunding magazine, website or elsewhere without permission. Late or incomplete submissions will be denied. Warning: Use of fictitious names, multiple addresses, and PO boxes to obtain additional rebates may constitute fraud, violate federal or state laws and may result in prosecution, terms of imprisonment, and/or fine under the U.S. Mail Fraud Statutes (Title 18, USC Sections 1341&1342). Offer void where restricted or prohibited by Federal or State Law. Global Equipment Co. reserves the right to rescind this offer at any time. If your rebate payment is \$10.00 or greater, you will receive a Visa Prepaid Card. Cards are issued by Citibank, N.A. pursuant to a license from Visa U.S.A. Inc. and managed by Cit Prepaid Services. Cards will not have cash access and can be used everywhere Visa debit cards are accepted. Cash advances are available at any Visa member bank branch for no fee. The Prepaid Visa Card will expire 12 months from the issuance date. In the event you prefer a check and upon receipt of your Prepaid Visa Card, simply call the toll free number on the back of the card and follow the telephone-prompts. Once you enter the card account information, opt out to speak to a live customer service representative and request a check. If your rebate is less than \$10.00, you will be paid by check. In the event your rebate check is not cashed within 90 days, the rebate offer expires and is void. Timely cashing of the rebate check is a necessary condition to obtain a rebate under this offer. Checks are void if not cashed within 90 days of issuance and cannot be reissued. Global Equipment Co. is not responsible for late, lost, misdirected or postage-due mail. You must have internet access, a valid email address and a printer in order to claim this rebate. You may check the status of your rebate by visiting the link provided in your email or visiting <http://globalindustrial.4myrebate.com>. Please allow 3 weeks after mailing to make an inquiry regarding your rebate. The name and address on your rebate application MUST match the name and address on the receipt/invoice. Only one rebate application per envelope. Allow up to 12 weeks for payment from date of postmark. For inquiries, call 1-800-286-9146 or visit <http://globalindustrial.4myrebate.com>

01-800-467-0529

chproductos.com

iii

WALL PANELS AND BINS



SC550201RD

Mounts easily on wall or shelving, carts, benches, inside cabinets, or service truck interiors. Premium Bins of all sizes may be moved or rearranged in unlimited configurations with no adjustment to panel. 16 gauge steel. For panel with bins add suffix Blue (BL), Red (RD) or Yellow (YL) for bin color. SC550148 and SC550150 are available in three colors. Add suffix Gray (GY), Blue (BL) or Tan (TN).

WALL PANEL 36"W x 19"H W/ BINS

Model	Bin Qty.	W" x D" x H"
SC550200	32	4 1/8 x 7 3/8 x 3
SC550201	18	5 1/2 x 10 7/8 x 5
SC550202	8	8 1/4 x 10 3/4 x 7
SC550203	8	8 1/4 x 14 3/4 x 7

WALL PANEL WITHOUT BINS

Model	W" x H"	Carton Qty.
SC550148	18 x 19	4
SC550150	36 x 19	4
SC239957	36 x 12	2
SC239956	27 x 21	2
SC239959	48 x 19	2
SC239955	18 x 61	2
SC239958	36 x 61	1
SC239960	48 x 61	1

Bin Size W" x D" x H"	BIN CAPACITY PER PANEL			
	18"W 19"H	36"W 19"H	27"W 21"H	36"W 61"H
4 1/8 x 4 1/2 x 3	16	32	30	120
4 1/8 x 5 3/8 x 3	16	32	30	120
4 1/8 x 7 3/8 x 3	16	32	30	120
4 1/8 x 10 7/8 x 4	12	32	18	80
5 1/2 x 10 7/8 x 5	9	18	12	60
5 1/2 x 13 1/2 x 5	9	18	12	60
5 1/2 x 14 3/4 x 5	9	18	12	60
8 1/4 x 10 3/4 x 7	4	8	---	28
8 1/4 x 14 3/4 x 7	4	8	---	28
8 1/8 x 18 x 9	4	8	---	24
11 x 10 7/8 x 5	3	9	6	30
11 x 16 x 8	1	6	---	21
11 x 18 x 10	1	3	---	15
16 1/2 x 10 7/8 x 5	3	6	4	20
16 1/2 x 14 3/4 x 7	2	4	---	14
16 1/2 x 18 x 11	1	2	---	10

PREMIUM STACKING BINS

These PREMIUM BINS can be compared feature for feature to the nationally branded bins. Reinforced walls add strength and rigidity and wide top ledge permits stable, higher stacking. Constructed of FDA approved water and corrosion proof polypropylene, to withstand freezers and autoclaves from -40°F to 250°F. Includes a full-width hanger lip, for use with louvers below. Anti-slide stop prevents shifting when stacked. Slotted label holders for easy identification. Specify color suffix when ordering bins: Blue (BL), Yellow (YL), Red (RD), Beige (BG), Green (GN) or Black (BK).

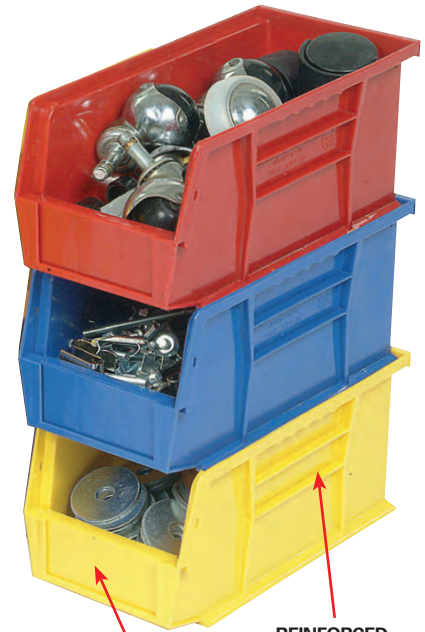

LARGE FRONT LABEL SLOT

REINFORCED RIBS

Overall W" x D" x H"	Carton Qty.	Model
4 1/8 x 4 1/2 x 3	24	SC269687
4 1/8 x 5 3/8 x 3	24	SC269680
4 1/8 x 7 3/8 x 3	24	SC269681
4 1/8 x 10 7/8 x 4	12	SC269688
5 1/2 x 10 7/8 x 5	12	SC269682
5 1/2 x 14 3/4 x 5	12	SC269689
8 1/4 x 10 3/4 x 7	6	SC269683
8 1/4 x 14 3/4 x 7	12	SC269684
11 x 10 7/8 x 5	6	SC269685
16 1/2 x 14 3/4 x 7	6	SC269686



HEAVY DUTY HOPPER BINS

These quality hopper bins feature a wide front opening for easy access, 1 rear and 2 side grip handles. Durable, easy-to-clean polypropylene resists rust, corrosion and most chemicals. Stabilizing ribs permit bins to stack 6 high. To identify contents, add Optional Labels. Add color suffix: Gray (GY), Blue (BL), Red (RD), Green (GN) and Beige (BG). Sold in carton quantities.

W" x D" x H"	Ctn. Qty.	Bin Model
19 7/8 x 15 1/4 x 12 7/16	3	SC752397

SC245097 Label fits SC752397 pkg. of 3

SUPER CAPACITY BIN RACKS

Qty.	Bin W" x D" x H"	Model
------	---------------------	-------

- A. BENCH RACK. 36"W x 20"H**
- 32 4¹/₈ x 7³/₈ x 3 **SC550152**
 - 18 5¹/₂ x 10⁷/₈ x 5 **SC550154**
 - 8 4¹/₈ x 5³/₈ x 3 **SC239349**
 - 8 4¹/₈ x 7³/₈ x 3
 - 6 5¹/₂ x 10⁷/₈ x 5
- B. SINGLE-SIDED FLOOR RACK. 36"W x 50"H**
- 96 4¹/₈ x 5³/₈ x 3 **SC550156**
 - 48 5¹/₂ x 10⁷/₈ x 5 **SC550160**
 - 24 11 x 10⁷/₈ x 5 **SC550162**
 - 24 8¹/₄ x 10³/₄ x 7 **SC550164**
 - 24 8¹/₄ x 14³/₄ x 7 **SC550166**
 - 12 16¹/₂ x 14³/₄ x 7 **SC550168**
 - 16 4¹/₈ x 7³/₈ x 3
 - 18 5¹/₂ x 10⁷/₈ x 5 **SC500163**
 - 8 8¹/₄ x 14³/₄ x 7
 - 16 4¹/₈ x 5³/₈ x 3 **SC239350**
 - 24 4¹/₈ x 7³/₈ x 3
 - 18 5¹/₂ x 10⁷/₈ x 5

- C. DOUBLE-SIDED MOBILE RACK. 36"W x 54"H**
- 192 4¹/₈ x 7³/₈ x 3 **SC550172**
 - 96 5¹/₂ x 10⁷/₈ x 5 **SC550174**
 - 48 11 x 10⁷/₈ x 5 **SC550176**
 - 48 8¹/₄ x 10³/₄ x 7 **SC550178**
 - 48 8¹/₄ x 14³/₄ x 7 **SC550180**
 - 24 16¹/₂ x 14³/₄ x 7 **SC550182**
 - 64 4¹/₈ x 4¹/₂ x 3
 - 16 8¹/₄ x 10³/₄ x 7 **SC500164**
 - 8 16¹/₂ x 14³/₄ x 7
 - 48 4¹/₈ x 7³/₈ x 3
 - 36 5¹/₂ x 10⁷/₈ x 5 **SC500165**
 - 16 8¹/₄ x 14³/₄ x 7

Organize, transport and store parts, components and hardware with maximum efficiency. Heavy duty 16 gauge steel louvered bin rack provides easy removal of premium polypropylene bins. Bins have hopper fronts with label area for instant access and inventory control. Free standing racks are ideal against walls, behind shelving or at the end of aisles. Double Sided Carts with handle and 3" rubber wheel casters allow you to move parts and hardware to different work sites. 500 lb. capacity. Gray enamel finish. Add suffix: Blue (BL), Red (RD) or Yellow (YL) for bin color. Fast and easy assembly.



B SC550166RD



C SC550176YL

CREATE YOUR OWN

Design your own storage unit and order bins from the preceding page. Louvers on rack are spaced every 2" to allow for bin height adjustment.

Type Rack	Overall W" x H"	Bin Width"				Model
		4 ¹ / ₈	5 ¹ / ₂	8 ¹ / ₄	11 16 ¹ / ₂	
Bench	36 x 20	8	6	4	3 2	SC184831
Floor	36 x 50	8	6	4	3 2	SC184832
Mobile	36 x 54	16	12	8	6 4	SC184833



A SC550154BL

STEEL SHELVING WITH PREMIUM BINS

Conveniently organizes parts and accessories for production or assembly. Includes premium polypropylene bins, featuring finger grips for easy handling, anti-slide stops and reinforced ribs to prevent spreading. Large label slots for quick identification. **Open style shelving** has anti-sway braces on back and sides for added stability. **Closed style shelving** has steel side and back panels that help minimize dirt and dust while keeping contents in place. Easy-to-assemble rugged steel shelving with long-lasting gray baked enamel finish. 12"D shelves have 400 lb. capacity per shelf. 18"D have a 375 lb. shelf capacity. Add suffix: Blue (BL), Red (RD) or Yellow (YL) for bin color. Only one bin color per shelving.



OPEN STYLE
SC603251BL



CLOSED STYLE
SC603261YL

Qty.	Bin W" x D" x H"	Shelves	OPEN STYLE Model	CLOSED STYLE Model
36"W x 12" D x 39"H UNIT				
15	11 x 10 ⁷ / ₈ x 5	6	SC603242	SC603257
9	11 x 10 ⁷ / ₈ x 5	6	SC603243	SC603258
12	5 ¹ / ₂ x 10 ⁷ / ₈ x 5	6		
9	11 x 10 ⁷ / ₈ x 5	6	SC603244	SC603259
8	8 ¹ / ₄ x 10 ³ / ₄ x 7	6		
30	5 ¹ / ₂ x 10 ⁷ / ₈ x 5	6	SC603245	SC603260
16	8 ¹ / ₄ x 10 ³ / ₄ x 7	5	SC603246	SC603261
Shelving Only		6	SC239600	SC239604
36"W x 18" D x 39"H UNIT				
16	8 ¹ / ₄ x 14 ³ / ₄ x 7	5	SC603247	SC603262
8	16 ¹ / ₂ x 14 ³ / ₄ x 7	5	SC603248	SC603263
8	8 ¹ / ₄ x 14 ³ / ₄ x 7	5	SC603249	SC603264
4	16 ¹ / ₂ x 14 ³ / ₄ x 7	5		
Shelving Only		6	SC239601	SC239605
36"W x 12" D x 73"H UNIT				
30	11 x 10 ⁷ / ₈ x 5	11	SC603250	SC603265
18	11 x 10 ⁷ / ₈ x 5	11	SC603251	SC603266
24	5 ¹ / ₂ x 10 ⁷ / ₈ x 5	11		
60	5 ¹ / ₂ x 10 ⁷ / ₈ x 5	11	SC603252	SC603267
36	8 ¹ / ₄ x 10 ³ / ₄ x 7	10	SC603253	SC603268
14	16 ¹ / ₂ x 14 ³ / ₄ x 7	8	SC506206	----
28	8 ¹ / ₄ x 10 ³ / ₄ x 7	8	SC506204	----
28	8 ¹ / ₄ x 14 ³ / ₄ x 7	8	SC506205	----
Shelving Only		11	SC239602	SC239606
36"W x 18" D x 73"H UNIT				
36	8 ¹ / ₄ x 14 ³ / ₄ x 7	10	SC603254	SC603269
18	16 ¹ / ₂ x 14 ³ / ₄ x 7	10	SC603255	SC603270
20	8 ¹ / ₄ x 14 ³ / ₄ x 7	10	SC603256	SC603271
8	16 ¹ / ₂ x 14 ³ / ₄ x 7	10		
15	11 x 18 x 10	8	SC506208	----
10	16 ¹ / ₂ x 18 x 11	8	SC506209	----
21	11 x 16 x 8	8	SC506207	----
Shelving Only		10	SC239603	SC239607

PICK RACK

Complete with Akro-Mils Shelf Bins

Inclined shelves permit excellent visibility and access to bin contents. Made of heavy-duty, 16-gauge steel, these racks have a gray enamel finish and are available in one sided table top or floor styles or mobile, two sided styles. Quality polypropylene Akro-Mils shelf bins won't rust, chip or crack and feature a generous label area, grips for easy handling, anti-slide stops and reinforced ribs. Mobile racks have 3" diameter casters (2 swivel and 2 rigid). Unit capacity 500 lbs. Easy assembly. Specify bin color suffix: Blue (BL), Red (RD), Yellow (YL), Green (GN) or White (WH)



C SC603427YL



B SC603426BL



A SC603424RD

A. BENCH RACK 33" x 12" x 21"H, 3 SHELVES

Description	Model
12 Bins-8"W	SC603423
24 Bins-4"W	SC603424

B. FLOOR RACK 33" x 12" x 61"H, 8 SHELVES

Description	Model
32 Bins-8"W	SC603425
64 Bins-4"W	SC603426

C. MOBILE RACK 36" x 26" x 65"H, 16 SHELVES

Description	Model
64 Bins-8"W	SC603427
128 Bins-4"W	SC603428

PREMIUM SHELF BINS & DIVIDERS

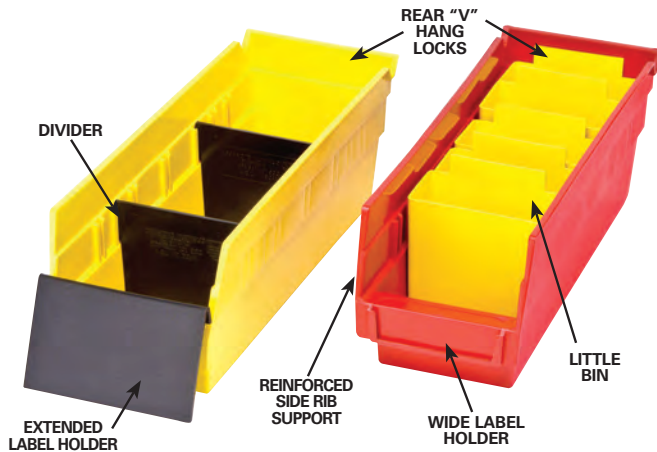

Plastic bins help efficiently organize 12", 18" and 24" deep shelving units, or racks. Bins are waterproof and chemical, grease and oil resistant. Reinforced ribbed construction for added strength. Features slotted label holder for easy content identification and a wide hopper front for easy access. Optional black divider fits across bin width. Nestable when empty to save space. Bins sold in carton quantity.

Overall W"	D"	H"	Model
3	x 12	x 4	SC184836
4	x 12	x 4	SC184837
7	x 12	x 4	SC184838
8	x 12	x 4	SC184843
11	x 12	x 4	SC184845
4	x 18	x 4	SC184839
7	x 18	x 4	SC184840
8	x 18	x 4	SC184844
11	x 18	x 4	SC184846
4	x 24	x 4	SC184841
7	x 24	x 4	SC184842
8	x 24	x 4	SC334190
11	x 24	x 4	SC184825

PREMIUM

Permanent, molded-in colored bins are virtually unbreakable. Use colors to differentiate items for quick content identification. *Specify color suffix when ordering: Blue (BL), Red (RD) or Yellow (YL), Green (GN) and Stone (BG) and Clear (CL).

SHELVING WITH HEAVY DUTY HOPPER BINS



SC238203GY

The ideal system for efficient storing small parts. Quality heavy-duty hopper storage bins feature a wide front opening for access with 2 side grip handles. The durable, easy-to-clean polypropylene construction resists rust, corrosion and most chemicals making them ideal for storage applications. Easy assembly. Boltless Shelving feature particleboard wood decking supported by double riveted beam for a shelf capacity of 1200 lbs. Specify Bin Color Suffix: Gray (GY), Blue (BL), Red (RD), Green (GN) and Beige (BG).

W" x D" x H"	Bin Qty	Color	Model
42"W x 15"D x 84"H BOLTLESS STEEL SHELVING, 5 SHELVES			
19 7/8 x 15 1/4 x 12 7/16	10	GY,BL,RD,GN,BG	SC238203

CORRUGATED BIN BOXES

Handy, reusable bins keep parts easily accessible. Heavy-test white faced corrugated fiberboard. Self-locking design is easy to set-up. No staples or tape needed. For easier organization, add Little Bins and Bin Dividers.



ADD OPTIONAL DIVIDER FOR BETTER PARTS SEPARATION

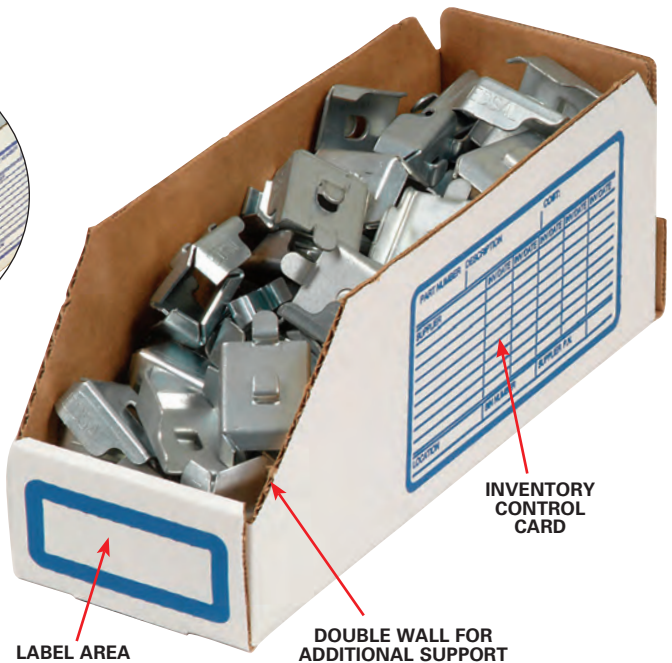

LABEL AREA

DOUBLE WALL FOR ADDITIONAL SUPPORT

INVENTORY CONTROL CARD

W" x H"	BINS FOR 12" SHELVING		BINS FOR 18" SHELVING	
	Model	Model	Model	Model
2 x 4 1/2	SC234802	SC234912	SC234912	SC234912
4 x 4 1/2	SC234804	SC234914	SC234914	SC234914
6 x 4 1/2	SC234806	SC234916	SC234916	SC234916
8 x 4 1/2	SC234808	SC234918	SC234918	SC234918
10 x 4 1/2	SC234810	SC234920	SC234920	SC234920
12 x 4 1/2	SC234812	SC234922	SC234922	SC234922

DIVIDERS		EXTRA LARGE BINS	
(Sold in pkgs. of 250)		(Sold in pkgs. of 25)	
W"	Model	W" x D" x H"	Model
2	SC250522	7 3/4 x 17 1/2 x 10	SC336406
4	SC250524	9 3/4 x 17 1/2 x 10	SC336408
6	SC250526	11 3/4 x 17 1/2 x 10	SC336410
8	SC250528	11 3/4 x 23 1/2 x 12	SC336412
10	SC250530	15 3/4 x 23 1/2 x 12	SC336414
12	SC250532		

STEEL SHELVING & PICK RACK WITH CORRUGATED BINS

Organize parts in these instant storage units. Our heavy-duty industrial steel shelving and pick rack combined with low-cost efficient white corrugated bins gives you the maximum in storage versatility. Bins are 12"D or 18"D x 4 1/2"H. Used by many leading companies. Shelving finished in baked gray enamel. Easily assembled.

Model Qty. Width" Shelves

A. STEEL SHELVING WITH BINS

36"W x 12" D x 39"H

SC235016 48 4 7

SC235034 Shelving Only 7

36"W x 12" D x 73"H

SC235009 48 8 13

SC235006 48 4 13

SC235002 96 4 13

48 2

SC235010 40 4 13

16 8

SC235005 96 2 13

48 4 13

SC235030 Shelving Only 13

36"W x 18" D x 39"H

SC235017 48 4 7

SC235036 Shelving Only 7

36"W x 18" D x 73"H

SC235011 48 8 13

SC235008 48 4 13

24 8 13

SC235004 96 4 13

48 2

SC235012 40 4 13

16 8

SC235032 Shelving Only 13

PICK RACK WITH BINS

Bin

Style Model Quantity W" x D" x H"

B SC235200 16 4 x 12 x 4 1/2

4 8 x 12 x 4 1/2

B SC235201 8 4 x 12 x 4 1/2

8 8 x 12 x 4 1/2

C SC235202 48 4 x 12 x 4 1/2

8 8 x 12 x 4 1/2

D SC235206 96 4 x 12 x 4 1/2

16 8 x 12 x 4 1/2



B

SC235201 BENCH RACK



C

SC235202 SINGLE SIDED FLOOR RACK



A

SC235002 STEEL SHELVING

D

SC235206 DOUBLE SIDED MOBILE RACK

PICK RACK WITHOUT BINS

Style Model W" x D" x H"

B SC235210 33 x 12 x 21

C SC235212 33 x 12 x 61

D SC235216 36 x 26 x 65

01-800-467-0529

chproductos.com



SC603446YL



SC603433BL

STEEL SHELVING

Complete with Akro-Mils Shelf Bins

These shelf and bin combinations store, sort and organize small parts and components conveniently. The quality, break-resistant polypropylene Akro-Mils shelf bins are designed with a generous label area, finger grips for easy handling, anti-slide stops for stacking and reinforced ribs for strength. Steel shelves have anti-sway bracing, simple assembly and are finished in durable gray enamel. Specify bin color suffix: Blue (BL), Red (RD), Yellow (YL), Green (GN) or White (WH).

Model	Bin		Shelves
	W" x D" x H"	Qty.	
36" W x 12" D x 39" H			
SC603429	7 x 12 x 4	30	7
SC603430	4 x 12 x 4	48	7
SC603431	8 x 12 x 4	24	7
SC603432	4 x 12 x 4	32	7
	7 x 12 x 4	10	
SC603433	4 x 12 x 4	24	7
	8 x 12 x 4	12	
36" W x 18" D x 39" H			
SC603434	8 x 18 x 4	24	7
SC603435	7 x 18 x 4	30	7
SC603436	4 x 18 x 4	24	7
	8 x 18 x 4	12	
SC603437	4 x 18 x 4	32	7
SC603438	7 x 18 x 4	10	
SC603438	4 x 18 x 4	48	7

Model	Bin		Shelves
	W" x D" x H"	Qty.	
36" W x 12" D x 73" H			
SC603439	8 x 12 x 4	48	13
SC603440	7 x 12 x 4	60	13
SC603441	4 x 12 x 4	48	13
	8 x 12 x 4	24	
SC603442	4 x 12 x 4	56	13
	7 x 12 x 4	25	
SC603443	4 x 12 x 4	96	13
36" W x 18" D x 73" H			
SC603444	8 x 18 x 4	48	13
SC603445	7 x 18 x 4	60	13
SC603446	4 x 18 x 4	48	13
	8 x 18 x 4	24	
SC603447	4 x 18 x 4	56	13
	7 x 18 x 4	25	
SC603448	4 x 18 x 4	96	13

STACKABLE WIRE BIN STORAGE



SC339024
WITH BIN DIVIDERS
AND DOLLY BASE

**100 lb. bin
capacity**



ONE WIRE BIN WITH TWO
OPTIONAL DIVIDERS

Easy Access Modular Storage

Interlocking modular bins organize, store and transport material in warehouse, production and assembly areas. Position bins side by side or back to back. Stacked up to 7 high. Open mesh permits quick inventory control. Industrial grade rust and corrosion-resistant welded .283 diameter wire frame, with .105 diameter cross wire construction for ultimate strength and rigidity. Maintenance free triple plated chrome finish. Optional dividers create a variety of compartment sizes. Assembles easily.

5 LEVEL PRECONFIGURED STORAGE UNIT

Bin Qty.	D" x H"	Ht."	36" WIDE	
			Model	Model
1	20 x 12	48	SC339011	SC339023
1	20 x 9			
3	14 x 9			
2	20 x 12	51	SC339012	SC339024
3	14 x 9			
2	20 x 12	51	SC339015	SC339027
3	20 x 9			
5	20 x 9			

DOLLY BASE

Turn your storage system into a mobile unit. Smooth rolling 5" x 1 1/4" polyurethane wheel swivel casters. For 20" deep bins.

Model	W" x D"
SC832132	36 x 20
SC832134	48 x 20

INDIVIDUAL BINS AND DIVIDERS

W" x D" x H"	BINS		DIVIDER Model
	Model	Model	
36 x 14 x 9	SC832108	SC832138	
48 x 14 x 9	SC832112	SC832138	
36 x 20 x 9	SC832108	SC832144	
48 x 20 x 9	SC832124	SC832144	
36 x 20 x 12	SC832114	SC832150	
48 x 20 x 12	SC832130	SC832150	

SECURITY BIN CABINET

Assembled or Easy to Assemble

800 Lb. Shelf Capacity

Available in a variety of bin and shelf combinations to meet your tool and small parts storage needs. Gray powder coat finish. **Floor Cabinets** are made using 16 gauge steel. Reinforced 4"D doors open 270° for full access to contents. Doors include pull handles and a cut-resistant padlockable hasp (lock sold separately) for security. Includes adjustable leveling feet. **Wall Mount Cabinets** are made using all welded 18 gauge steel. Flush, channel reinforced doors feature a 2-point locking handle. **Shelves** have an 800 lb. shelf capacity for superior strength. Bins are made with break and corrosion resistant polypropylene. Hopper front for easy access to contents. Rear hanging lip for easy attachment and removal from louvered panels. Withstands temperatures up to 250°F. **Specify Bin Color Suffix: Blue (BL), Red (RD) or Yellow (YL).**

CHOOSE FROM 4 CABINET STYLES:

- Style A** – All bins in interior and doors
- Style B** – Combination of bins and shelving in interior and doors
- Style C** – Shelving only in interior & Bins on doors
- Style D** – Shelving only in interior and doors (No Bins)
- Style E** – Yellow Bins only in interior (Flush Doors)



D SC662142



HEAVY-DUTY HINGES



CUT-RESISTANT
PADLOCK HASP FOR
ADDED SECURITY



A SC603401YL

BINS		SHELVES		Bin Size		EASY ASSEMBLY Model	ASSEMBLED Model
Interior	Door	Interior	Door	W" x D" x H"	Style		
38" W x 24" D x 72" H CABINET WITH BINS							
---	96	---	---	4 1/8 x 5 3/8 x 3	A	SC662143	SC662132
60	---	---	---	5 1/2 x 10 7/8 x 5	A	SC662143	SC662132
---	96	---	---	4 1/8 x 5 3/8 x 3	A	SC662144	SC662133
36	---	---	---	5 1/2 x 10 7/8 x 5	A	SC662144	SC662133
12	---	---	---	8 1/4 x 14 3/4 x 7	A	SC662144	SC662133
---	96	---	---	4 1/8 x 5 3/8 x 3	A	SC662145	SC662134
24	---	---	---	5 1/2 x 10 7/8 x 5	A	SC662145	SC662134
16	---	---	---	8 1/4 x 14 3/4 x 7	A	SC662145	SC662134
---	48	---	---	4 1/8 x 5 3/8 x 3	A	SC603400	SC603401
24	48	---	---	4 1/8 x 7 3/8 x 3	A	SC603400	SC603401
16	---	---	---	5 1/2 x 10 7/8 x 5	A	SC603400	SC603401
---	48	---	---	8 1/4 x 14 3/4 x 7	A	SC603400	SC603401
---	48	---	---	4 1/8 x 5 3/8 x 3	A	SC662136	SC662147
---	48	---	---	4 1/8 x 7 3/8 x 3	A	SC662136	SC662147
18	---	---	---	5 1/2 x 10 7/8 x 5	A	SC662136	SC662147
12	---	---	---	8 1/4 x 14 3/4 x 7	A	SC662136	SC662147
6	---	---	---	16 1/2 x 14 3/4 x 7	A	SC662136	SC662147
---	48	2	6	4 1/8 x 5 3/8 x 3	B	SC662148	SC662137
24	---	---	---	5 1/2 x 10 7/8 x 5	B	SC662148	SC662137
---	48	2	6	4 1/8 x 5 3/8 x 3	B	SC662149	SC662138
12	---	---	---	5 1/2 x 10 7/8 x 5	B	SC662149	SC662138
8	---	---	---	8 1/4 x 14 3/4 x 7	B	SC662149	SC662138
---	48	2	6	4 1/8 x 7 3/8 x 3	B	SC662150	SC662139
16	---	---	---	8 1/4 x 14 3/4 x 7	B	SC662150	SC662139
---	96	5	---	4 1/8 x 5 3/8 x 3	C	SC662152	SC662141
---	---	5	14	---	D	SC662153	SC662142



B SC662138BL



C SC662141RD



LOCKING BIN CABINET

- High-Volume Storage
- Organize Parts
- Prevent Theft

Store and organize while protecting against theft, loss, dust and dirt. Molded, high impact, break resistant yellow polypropylene plastic bins have large hopper front for easy access and quick identification of contents. Bins store conveniently on 230 lb. adjustable steel shelves. Reinforced doors open a full 180° for complete access and feature a three-point locking system for reliable protection. Durable powder coat finish resists chipping and scratching.

SC239388

Complete with Plastic Bins

W" x D" x H"	Bin Qty.	Shelves	UNASSEMBLED Model	ASSEMBLED Model
48"W x 24"D x 78"H CABINET WITH CLEAR DOOR.				
8 1/4 x 14 3/4 x 7	20	7	SC239385	SC239387
8 1/4 x 14 3/4 x 7	23	7	SC239386	SC239388
16 1/2 x 14 3/4 x 7	6			

GLOBAL[®] NESTING TOTE



Ideal for transporting items and materials. Can be used on conveyor systems for transport. Durable gray polyethylene tote is corrosion resistant. Provides excellent service for storing a wide range of items. Tote is nestable when not in use for convenient space saving storage. Measures 20 1/4"W x 15 1/4"D x 5"H.

Model	O.D. L" x W" x H"	Ctn. Qty.
SC443326	20 1/4 x 15 1/4 x 5	9

ALUMINUM TOTE BOX CART



All aluminum cart rolls smoothly on four 5" swivel polyolefin casters. Slide runners support tote boxes and allow quick, easy access. Order tote boxes separately.



BLUE NYLON COVER
SC652865 For 3 Tote Cart
SC652866 For 6 Tote Cart

SC892113 SHOWN WITH OPTIONAL NYLON COVER

SC892114
 SHOWN WITH SIX
 SC334180GY

Overall L" x W" x H"	Tote Qty.	Cap lbs.	EASY TO ASSEMBLE Model
23 x 16 x 19	1	100	SC892112
28 x 16 x 33	2	200	SC652725
26 x 19 x 41	3	300	SC892113
26 x 19 x 70	6	600	SC892114

CROSS-STACK & NEST LUG/TOTE BOX



SC334180GY

Easy 90° positive cross-stacking, allows access to contents. Nests to save space when empty. Rugged one piece polyethylene tote box won't crack or rust. Cleans easily. FDA approved material. Sold in carton quantities of 6. **Add suffix when ordering: Gray (GY), Blue (BL) or White (WH).**

O.D. L" x W" x H"	Capacity Cubic"	Capacity Gal.	Carton Qty.	TOTE Model	LID Model
25 1/8 x 16 x 8 1/2	2160	9.35	6	SC334180	SC603001

NEST & STACK SHIPPING TOTE

**180° Turn Allows
Stack & Nest**

Made with injection molded, high density polyethylene to withstand extreme temperatures from -10°F to 250°F. Complies with **USDA** and **FDA** regulations for use in food processing applications. Totes won't crack or corrode and are waterproof. 180 degree nest and stacking saves valuable storage space. Fits on standard 48" x 40" pallets. Features a textured bottom to ensure a non-slip grip during transport. **Optional Lid** protects contents and accepts security tie closure for added security. Sold in carton quantities. **Specify color suffix: Blue (BL), Gray (GY) or Red (RD).**

Top Outside L" x W" x H"	Lbs. Cap		Ctn. Qty.	TOTE Model	LID Model
	Box	Stacked			
18 x 11 x 6	45	225	6	SC274311	SC274321
18 x 11 x 9	90	450	6	SC274312	SC274321
19 1/2 x 13 1/2 x 8	65	325	6	SC274313	SC274322
19 1/2 x 15 1/2 x 10	55	275	6	SC274314	SC274323
19 1/2 x 15 1/2 x 13	65	325	6	SC274315	SC274323
23 1/2 x 15 1/2 x 12	90	450	3	SC274316	SC274324
23 1/2 x 19 1/2 x 10	45	225	6	SC274317	SC274325
23 1/2 x 19 1/2 x 13	75	375	3	SC274318	SC274325
29 1/2 x 19 1/2 x 15	100	500	3	SC274319	SC274326

Model	Description
SC239893	Security Cable Tie (Pkg of 375)



GLOBAL DISTRIBUTION CONTAINER

Safely and securely ship and distribute materials with these durable, affordable shipping containers. Interlocking lids are permanently attached using steel hinges. Raised lip edges allow secure stacking. **Molded from high density FDA approved polyethylene.** Containers allow nesting when not in use with lids open for compact storage and to help reduce return shipping costs. Molded grip handles have an integral hasp to accept cable ties for security. Sold in carton quantities. **Specify Color Suffix: Gray (GY), Blue (BL) or Red (RD).** SC443167 translucent container includes metal rails for hanging folders.



Model	Top Outside L" x W" x H"	Cap. Lbs. Alone Stacked	Stack Qty.	Ctn. Qty.	
					SC442218
SC257808	21 7/8 x 15 1/4 x 9 11/16	45	225	5	6
SC257809	21 7/8 x 15 1/4 x 12 7/8	50	250	5	6
SC257813	23 3/4 x 19 1/4 x 12 1/2	50	250	5	3
SC257814	27 3/16 x 16 5/8 x 12 1/2	50	250	5	3
SC238148	28 1/8 x 20 3/4 x 15 5/8	60	300	5	1

Security Nylon Cable Tie assortment includes 3 sizes in 5 colors - 4"L x 0.092"W, 6 1/2"L x 0.095"W and 7 1/2"L x 0.187"W. Colors include Yellow, Red, Blue, Black and Clear. 25 ties in each color and size. 375 ties in total. Model **SC239855**

CHROME WIRE CARTS

Easily slide bins in and out for access and storage. Slides are height adjustable at 1" increments. Dividable bins allow multiple configurations within each bin, and are made of high-density FDA approved polyethylene that resists most solvents and chemicals. 1,200 lb. capacity. Top and bottom chrome wire shelves feature truss perimeter for extra strength while allowing light, air and sprinkler penetration. Moves easily on four 5" polyurethane swivel casters (2 with brakes). Easy assembly. **Add suffix: Blue (BL), Gray (GY) or Red (RD) for bin color.**



SC269027

Model	Description	Overall Cart W" x D" x H"	Levels	Bin Size L" x W" x H"	
				Levels	Bin Size L" x W" x H"
SC269562	Cart Only	24 x 21 x 45	4	---	---
SC269027	Cart w/ 4 Containers	24 x 21 x 45	4	22 1/2 x 17 1/2	6
SC269030	Cart Only	24 x 21 x 69	7	---	---
SC269028	Cart w/ 7 Containers	24 x 21 x 69	7	22 1/2 x 17 1/2	6
SC269029	Cart w/ 11 Containers	24 x 21 x 69	7	22 1/2 x 17 1/2	3

EASY ACCESS CONTAINER TRUCK

Perfect for parts picking and assembly operations. Slant shelves allow easy access and provide content visibility. Durable steel construction with chrome plated finish. Includes 3 slant shelves, and flat shelves on top and bottom levels for additional storage. Shelves easily adjust at 1" increments on numbered posts for tool free adjustments. Includes four 5" polyurethane swivel casters for easy mobility. **Model 239429 truck only.** Holds up to eight 16 1/2"L x 10 7/8"W x 6"H containers. Overall dimensions: 70"H x 36"W x 18"D. Easy Assembly. **Add suffix Blue (BL), Red (RD) or Gray (GY) for container color.**



TRUCK Model
SC239429

Model	Container Qty.	Fit Container Size	
		W" x D" x H"	Size
SC239429	---	16 1/2 x 10 7/8	6 x 6
SC268999	12	16 1/2 x 10 1/2	3 1/2 x 6
SC269000	12	16 1/2 x 10 1/2	6 x 6
SC269001	12	16 1/2 x 10 1/2	8 x 8

**SHOWN WITH EIGHT
GRAY CONTAINERS**
SC334103GY (See p.10)
or SC772028 (See p.20)

DIVIDABLE GRID CONTAINERS

Dividable to 1 1/8" Square Available in Standard or Conductive.

Heavy-Duty Dividable Grid Containers can be used in industrial, commercial, electronic and health care industries for storage, assembly, fabrication and distribution applications. These containers offer the safest and most efficient method of compartmentalizing and protecting all kinds of small to medium size parts allowing you to customize the container interior for your exact needs. Molded-in stacking ridge assures containers will **stack securely with or without covers**. Containers are designed to maximize space in storage and transportation. Compatible with most racks, shelving and automated, material handling equipment, stacking rims and multi-ribbed external sides provide high impact strength. Large, smooth surface area on all four sides for content identification. Optional **clear, plastic label holder** attaches securely with Velcro® Brand fasteners to any size container (available in 3 sizes). Containers can be divided by length and/or width allowing subdivision down to a 1 1/8" square compartment size. **STANDARD GRID CONTAINERS** are available in 9 sizes and 3 colors: Blue, Gray and Red. **Injection molded from high density FDA approved polyethylene** which resists most solvents and chemicals. Snap on clear or same colored covers protect content from damage or dust in shipping and storage. **Add Color Suffix: Blue (BL), Gray (GY) or Red (RD)**. Containers sold in carton quantities.

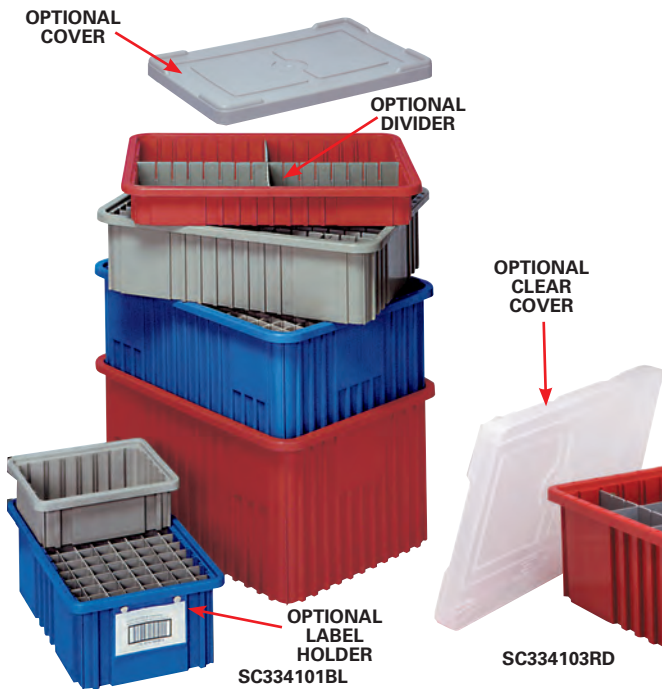

STANDARD BOX		Carton Qty.	Cap. Lbs.	Model
Outside L" x W" x H				
10 7/8 x 8 1/4 x 3 1/2	20	20	25	SC334100
10 7/8 x 8 1/4 x 5	20	25	25	SC334101
16 1/2 x 10 7/8 x 3 1/2	12	25	25	SC334102
16 1/2 x 10 7/8 x 6	8	35	35	SC334103
16 1/2 x 10 7/8 x 8	8	40	40	SC334104
22 1/2 x 17 1/2 x 3	6	25	25	SC334105
22 1/2 x 17 1/2 x 6	3	35	35	SC334106
22 1/2 x 17 1/2 x 8	3	40	40	SC334107
22 1/2 x 17 1/2 x 12	3	60	60	SC334108



NESTING UTILITY TOTE & LID

Lightweight, tough **Corrugated Plastic tote** is steel band reinforced at top for added strength and rigidity. Easy-to-clean, resistant to dirt, moisture and grease. Convenient hand-holes for carrying ease. Nests for space-saving storage. Snug-fitting lid protects contents against dust and dirt. 18 1/2" L x 13 1/4" W x 12" H. Meets U.S. Postal Service requirements. **Add Color Suffix when ordering Blue (BL), Red (RD) or Yellow (YL)**. Mail Tray features folded, double sidewall construction. Nest together to save space. white color only. 24 1/2" L x 12" W x 4 1/2" H. Sold in carton quantities of 10.

Strong and Economical

Description	WHITE	COLORS
	Model	Model
Tote	SC753500	SC257915
Lid	SC753501	SC257916
Tote & Lid	SC257816	SC257920
Mail Tray	SC238431	----

SUPER VALUE! EASY ASSEMBLY BULK CONTAINERS



Made from structurally reinforced high density blue polypropylene. Hold up to 600 lbs. Included feet allow containers to stack up to 4 high for 2000 lb. total capacity. Stacking feet allow 4-way fork entry. Easy-to-assemble with included hardware. Ships flat for reduced shipping costs. Measures 39 1/4" L x 31 1/2" W x 29" H overall. Available with mesh or solid sides. **Hinged Lid and Caster Kit** sold separately. Caster Kit with swivel casters (2 with brakes) withstands 2000 lb. loads.

Model	Description
SC603087	Mesh sides container
SC239452	Solid sides container
SC239453	Solid hinged lid
SC603088	Casters (4 swivel, 2 locking)

FOLDING WIRE CONTAINER

Sets Up in Seconds, Folds Flat to Save Space and Shipping Costs

These one piece containers are made from strong, arc welded wire mesh with heavily reinforced corners and a channel-formed steel base. The open mesh allows excellent visibility of contents and inventory control with minimal dust build up. Sets up and folds in seconds for valuable time and space savings. Notched legs interlock for positive stacking and permit forklift or pallet truck entry. Drop gate allows access when stacked. Container with Hinged Lid is padlockable for security. Mobilize your container with the optional Caster Kit.



FOLDS FOR COMPACT STORAGE

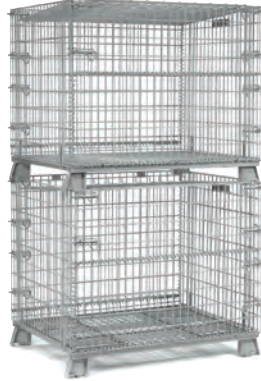

STACKS 4 HIGH

DROP GATE FOR EASY ACCESS WHEN STACKED



SHOWN WITH OPTIONAL HINGED LID AND CASTER KIT

CONTAINER Overall L" x W" x H"	Inside Ht."	Drop Gate Side"	Wt.	Model
1000 LB. CAP. - Sides & Bottom 1" x 1", Powder Coat Finish	32 x 20 x 21	16	32	SC198642
2000 LB. CAP. - Sides & Bottom 2" x 2", Powder Coat Finish	40 x 32 x 34 1/2	28	40	SC239341
	48 x 40 x 36 1/2	30	48	SC239342
	48 x 40 x 42 1/2	36	48	SC239343
4000 LB. CAP. - Sides & Bottom 2" x 2" Powder Coat Finish	40 x 32 x 34 1/2	28	40	SC239344
	48 x 40 x 36 1/2	30	48	SC239345
	48 x 40 x 42 1/2	36	48	SC239346

Hinged Lid:

Fit Container	Model
40"L x 32"W	SC275976
48"L x 40"W	SC275977

CasterKit: 4 swivel, 2 braking, 5" x 1 1/2" mold-on rubber casters. 1400 lb. capacity. **Model SC652395**

PADLOCK Model
SC336375B

NYLON COVER



NYLON COVER keeps contents hidden, secure, and dust free. Made of water resistant 400 denier nylon with reinforced corners and double stitching for added durability. Flip front door panel with hook and loop tape to attach cover to container.

NYLON COVER

Model	L" x W" x H"
SC198662BL	32 x 20 x 21
SC198664BL	40 x 32 x 34 1/2
SC198666BL	48 x 40 x 36 1/2
SC198668BL	48 x 40 x 42 1/2

MULTI-DRAWER CABINET



SC986102

Welded steel construction. Smooth gliding 3"W x 8"D x 2 1/2"H drawers with drawer stops prevent accidental pull-out. Sturdy drawer pull with label holder and labels. Fully assembled; ready for instant use. Gray enamel finish.

Model	Drawers	W" x D" x H"
SC986103	50	36 x 9 x 17 3/4
SC986102	100	36 x 9 x 34 1/2

PARAMOUNT MODULAR CABINET

All-welded steel modular cabinet has an attractive refined appearance with heavy-duty construction. **200 lb. capacity** drawers lock with central cylinder locks with 2 keys included. (keyed differently) Build-in drawer locking system prevents accidental tipping. Drawers open easily on side mounted tracks. Roller glides allow full-access drawer extension. Full width handles for better grip and a flush, catch-free front. Label with plastic cover on each drawer handle allows easy labeling of drawer contents. Drawers accept optional Divider and Partition Kits to create multiple compartments for organized storage. Cabinet includes four 5"H drawers and one 6"H drawer. Blue color finish. Measures 30"W x 27"D x 32"H.



SWIVEL GLIDES



TOP TRAY & MAT KIT



DIVIDER KIT & DRAWER MAT



FORKLIFTABLE BASE



SHOWN WITH OPTIONAL PUSH HANDLE AND WHEEL KIT (SC493324)

OPTIONAL ACCESSORIES

Model	Model
Divider Kit (3 long partition and 6 short dividers)	SC493321
Reinforced Bases	SC493322
Height Adjusting Swivel Glides (4 pieces)	SC493323
Push Handles and Wheel Kit (2 Swivel, 2 Rigid)	SC493324
Drawer Mat Kit (Back, 5 pieces)	SC493325
Top Tray with Vinyl Mat	SC493326

NEXELATE SILVER EPOXY WIRE SHELVING & TRUCKS

Your Best Buy For Dry Storage Applications
The Next Generation Shelf Finish!

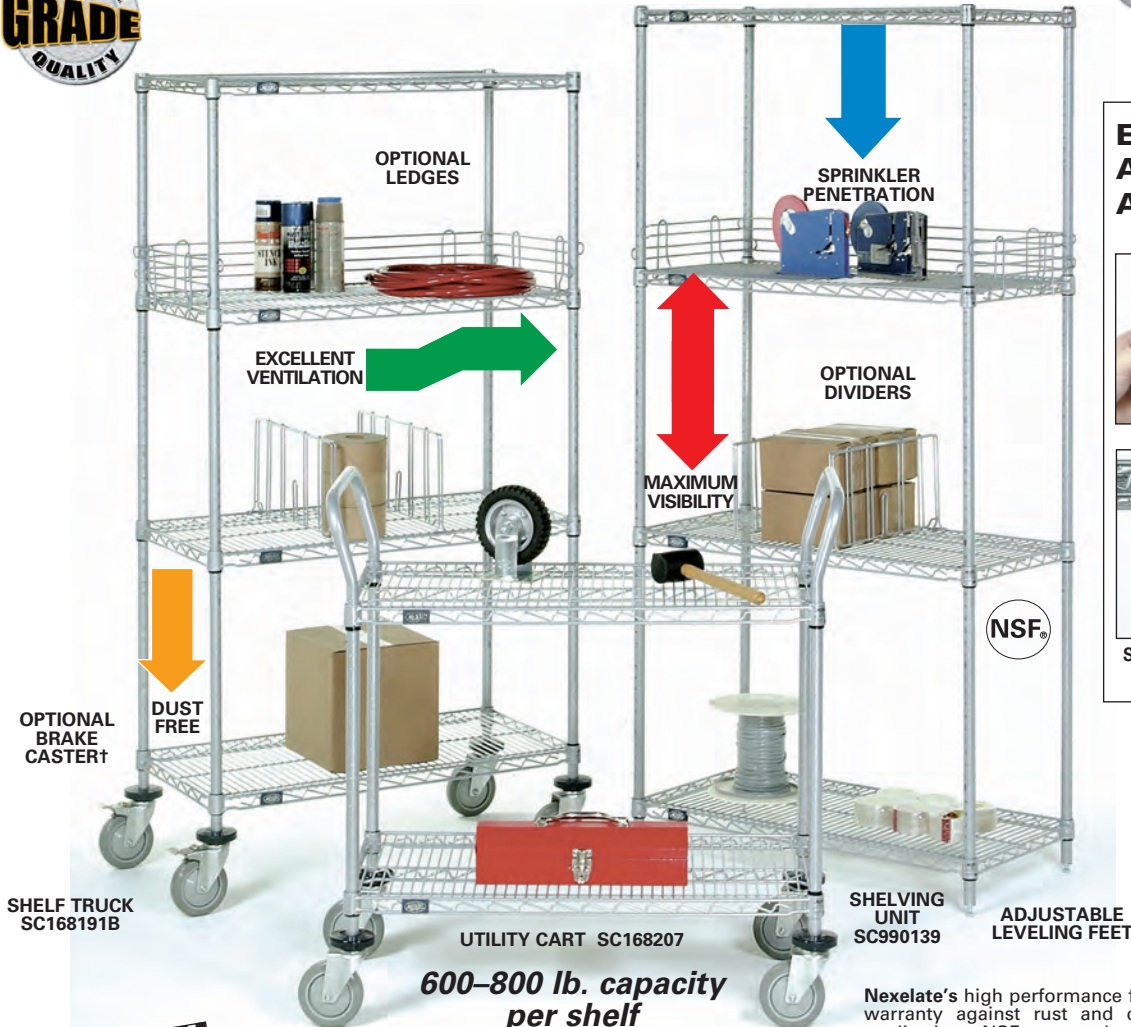
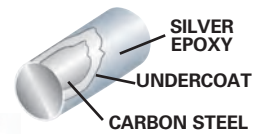

EASY ASSEMBLY & ADJUSTMENT

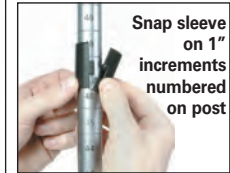

Snap sleeve on 1" increments numbered on post



Slide shelf over sleeve for secure, positive locking

Shelves Are Adjustable on 1" Increments

SHELF TRUCK SC168191B

UTILITY CART SC168207

SHELVING UNIT SC990139

ADJUSTABLE LEVELING FEET

600-800 lb. capacity per shelf

Nexelate's high performance finish has a 7 year limited warranty against rust and corrosion in wet or dry applications. NSF approved.



UTILITY CART† 800 lb. Capacity, 38"H.
Four swivel 5" Polyurethane Casters.

W"x D"	2 Shelf Model	3 Shelf Model
36 x 18	SC168207	SC168210
36 x 24	SC168208	SC168211
48 x 24	SC168209	SC168212

LEDGES

L"x H"	Model
18 x 4	SC990171
24 x 4	SC990172
36 x 4	SC990173
48 x 4	SC990174
60 x 4	SC990175
72 x 4	SC990176

SHELF DIVIDERS

D" x H"	Model
18 x 8	SC990177
24 x 8	SC990178

SHELF TRUCK† 1200 lb. Capacity, 4 shelf. Four swivel 5" Polyurethane Casters.

W"x D"x H"	Model
36 x 18 x 69	SC168191
48 x 18 x 69	SC168192
60 x 18 x 69	SC168193
72 x 18 x 69	SC168194
36 x 24 x 69	SC168195
48 x 24 x 69	SC168196
60 x 24 x 69	SC168197
72 x 24 x 69	SC168198
36 x 18 x 80	SC168199
48 x 18 x 80	SC168200
60 x 18 x 80	SC168201
72 x 18 x 80	SC168202
36 x 24 x 80	SC168203
48 x 24 x 80	SC168204
60 x 24 x 80	SC168205
72 x 24 x 80	SC168206

† Optional brake caster (2) add "B" to model number

W"x D"x H"	STARTER UNIT 4 posts, 4 shelves and snap sleeves. Model	ADD-ON UNIT 2 posts, 4 shelves, snap sleeves and 8 "S" shelf hooks. Model	ADDITIONAL SHELF Model
36 x 18 x 63	SC990131	SC990147	SC990163
48 x 18 x 63	SC990132	SC990148	SC990164
60 x 18 x 63	SC990133	SC990149	SC990165
72 x 18 x 63	SC990134	SC990150	SC990166
36 x 24 x 63	SC990135	SC990151	SC990167
48 x 24 x 63	SC990136	SC990152	SC990168
60 x 24 x 63	SC990137	SC990153	SC990169
72 x 24 x 63	SC990138	SC990154	SC990170
36 x 18 x 74	SC990139	SC990155	SC990163
48 x 18 x 74	SC990140	SC990156	SC990164
60 x 18 x 74	SC990141	SC990157	SC990165
72 x 18 x 74	SC990142	SC990158	SC990166
36 x 24 x 74	SC990143	SC990159	SC990167
48 x 24 x 74	SC990144	SC990160	SC990168
60 x 24 x 74	SC990145	SC990161	SC990169
72 x 24 x 74	SC990146	SC990162	SC990170

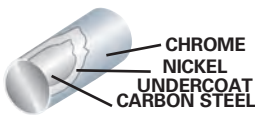

CHROME WIRE SHELF TRUCK

Your Best Choice For Dry Storage Applications

Durable and Reliable

1200 lb. capacity

Electro-plated nickel-chrome resulting in a brilliant high gloss finish that is both hard and durable. A high tech look at an economical price! This industry standard has proven to be a favorite and perfect for display and dry storage. 1 Year Limited Warranty when used in a dry storage application.

QUICK ASSEMBLY CLIP



Shelves adjust on 1" increments. Numbered posts for quick assembly.



Simply snap together and slide shelf over sleeve for positive locking.

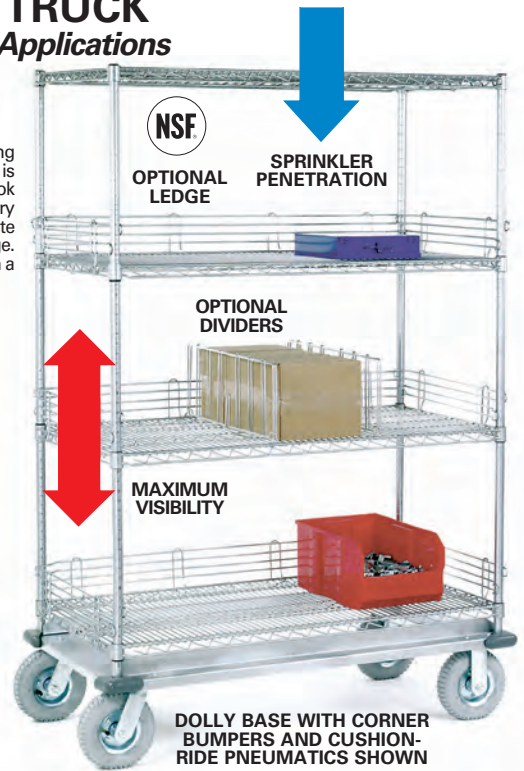
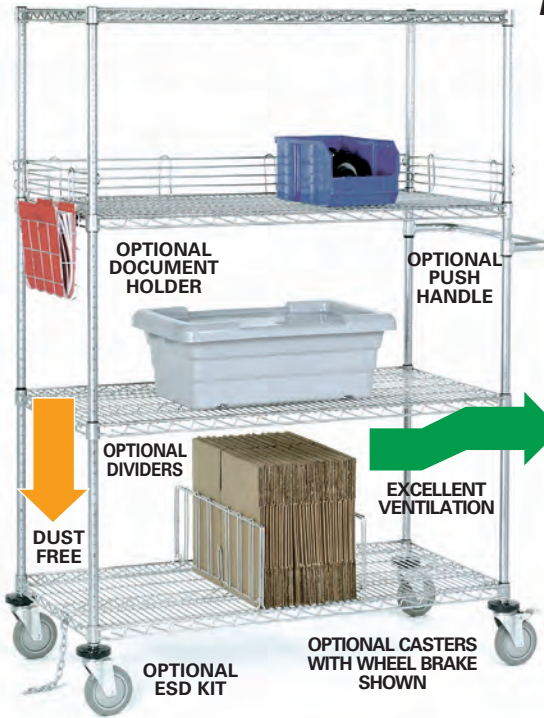

Don't Forget These Great Accessories!



NYLON COVER- Keep contents dust and dirt free. Made of water resistant 400 denier blue nylon with reinforced corners and double stitching for added durability. Two pockets allow 8 1/2" x 11" documents to travel with products. Simple hook and loop closure.

WIRE LEDGES- Chrome. Prevents items from falling off.

L" x H"	Model
18 x 4	SC188580J
24 x 4	SC188582J
36 x 4	SC188584J
48 x 4	SC188586J
60 x 4	SC188588J
72 x 4	SC188590J

DOCUMENT HOLDER- 12 3/8" L x 2" W x 8 5/8" H.
 Model SC579210C

ESD CONVERSION KIT- Includes conductive Aluminum Shelf Sleeves and dissipative ground chain
 Model SC241418

PUSH HANDLE- Chrome finish. Adjusts easily on 1" increments.

Size"	Model
18	SC703164J
24	SC703165J

WIRE SHELF DIVIDERS- Chrome. Attaches at any point along shelf.

L" x H"	Model
18 x 8	SC188595J
24 x 8	SC188596J

5" x 1 1/4" POLYURETHANE WHEEL SWIVEL CASTERS & DONUT BUMPERS
 1200 LB. CAPACITY

W" x D" x H"	Model
36 x 18 x 69	SC168214
48 x 18 x 69	SC168215
60 x 18 x 69	SC168216
72 x 18 x 69	SC168217
36 x 24 x 69	SC168218
48 x 24 x 69	SC168219
60 x 24 x 69	SC168220
72 x 24 x 69	SC168221
36 x 18 x 80	SC168222
48 x 18 x 80	SC168223
60 x 18 x 80	SC168224
72 x 18 x 80	SC168225
36 x 24 x 80	SC168226
48 x 24 x 80	SC168227
60 x 24 x 80	SC168228
72 x 24 x 80	SC168229

6" x 2" RUBBER TIRED WHEELS (2 SWIVEL, 2 RIGID) DOLLY BASE AND CORNER BUMPERS.
 1600 LB. CAPACITY

W" x D" x H"*	Model
36 x 18 x 63	SC168230
48 x 18 x 63	SC168231
60 x 18 x 63	SC168232
36 x 24 x 63	SC168233
48 x 24 x 63	SC168234
60 x 24 x 63	SC168235
36 x 18 x 74	SC168236
48 x 18 x 74	SC168237
60 x 18 x 74	SC168238
36 x 24 x 74	SC168239
48 x 24 x 74	SC168240
60 x 24 x 74	SC168241

8" x 2 1/2" FULL PNEUMATIC WHEELS (2 SWIVEL, 2 RIGID) FOR AIR CUSHIONED RIDE DOLLY BASE AND CORNER BUMPERS. 1200 LB. CAPACITY

W" x D" x H"*	Model
36 x 18 x 63	SC168242
48 x 18 x 63	SC168243
60 x 18 x 63	SC168244
36 x 24 x 63	SC168245
48 x 24 x 63	SC168246
60 x 24 x 63	SC168247
36 x 18 x 74	SC168248
48 x 18 x 74	SC168249
60 x 18 x 74	SC168250
36 x 24 x 74	SC168251
48 x 24 x 74	SC168252
60 x 24 x 74	SC168253

W" x D"	63" HIGH Model	74" HIGH Model
36 x 18	SC241750BL	SC241758BL
48 x 18	SC241751BL	SC241759BL
60 x 18	SC241752BL	SC241760BL
72 x 18	SC241753BL	SC241761BL
36 x 24	SC241754BL	SC241762BL
48 x 24	SC241755BL	SC241763BL
60 x 24	SC241756BL	SC241764BL
72 x 24	SC241757BL	SC241765BL

*Casters with wheel brake for all 5" dia. wheel models; add "B" to model.

*For overall height, add caster size plus 1"

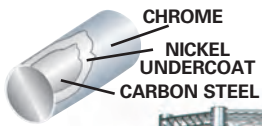

NEXEL CHROME WIRE SHELVING

So Strong . . . It's Patented!
Designed For Years of Heavy Duty Service

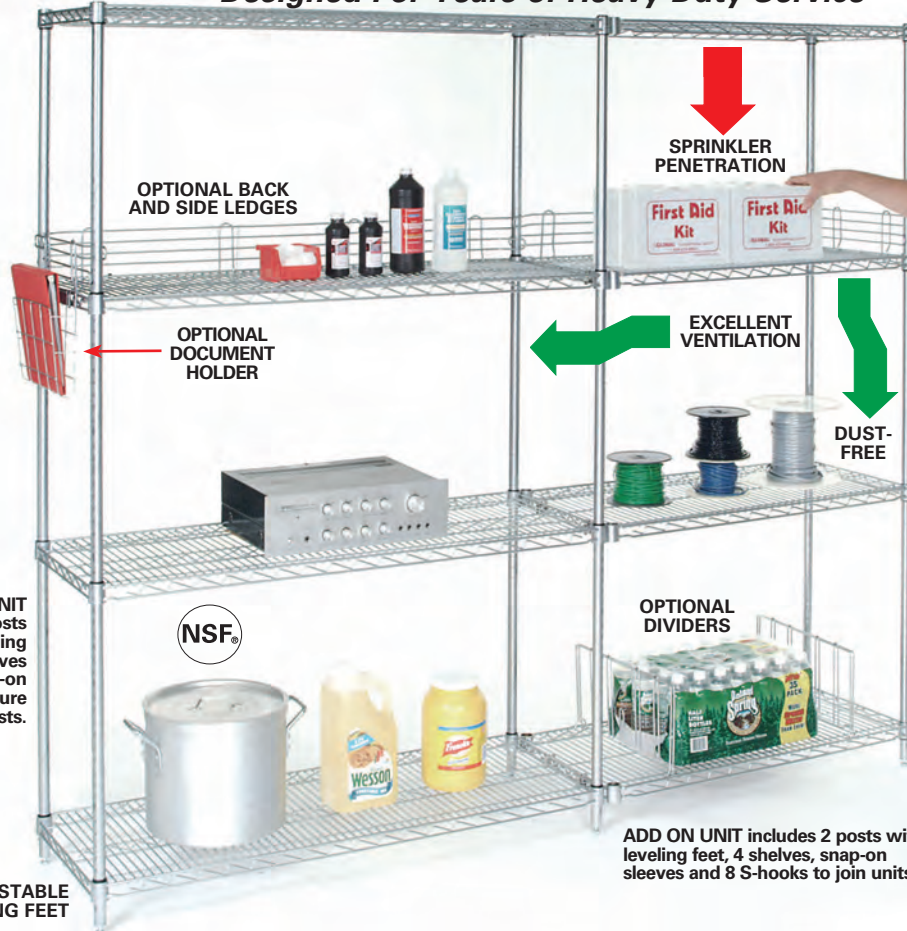

STARTER UNIT includes 4 posts with leveling feet, 4 shelves and snap-on sleeves to secure shelves to posts.

ADJUSTABLE LEVELING FEET

ADD ON UNIT includes 2 posts with leveling feet, 4 shelves, snap-on sleeves and 8 S-hooks to join units.

Nexel® Chrome Wire Shelving Units feature a lustrous high gloss finish with a 1 year limited warranty in dry applications. These units provide an attractive look that's ideal for retail display and is rugged for stock effective, long lasting storage. NSF approved.



Snap sleeve around numbered post.

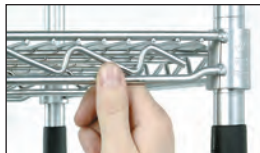

Slide shelf over sleeve for secure, positive locking.

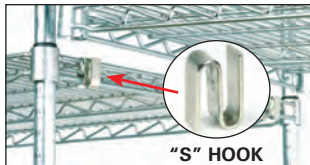

Two "S" hooks are used to connect add-on wire shelf to starter wire shelf.

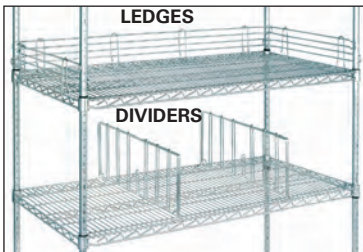

LEDGES

L" x H"	Model
14 x 4	SC188561
18 x 4	SC188580
24 x 4	SC188582
30 x 4	SC188583
36 x 4	SC188584
42 x 4	SC188585
48 x 4	SC188586
54 x 4	SC188589
60 x 4	SC188588
72 x 4	SC188590

SHELF DIVIDERS

D" x H"	Model
14 x 8	SC188563
18 x 8	SC188595
24 x 8	SC188596
30 x 12	SC188598
36 x 12	SC188599

DOCUMENT HOLDER

D" x H"	Model
12 ³ / ₈ " W x 2" D x 8 ⁵ / ₈ " H	SC489070

INDIVIDUAL SHELVES include snap-on sleeves and are available in 600 or 800 lb. capacities (depending on shelf width).

W" x D"	Model	W" x D"	Model
24 x 14	SC188565	24 x 24	SC188713
30 x 14	SC188566	30 x 24	SC188714
36 x 14	SC188567	36 x 24	SC188556
42 x 14	SC188568	42 x 24	SC188715
48 x 14	SC188569	48 x 24	SC188558
54 x 14	SC188336	54 x 24	SC188339
60 x 14	SC188570	60 x 24	SC188560
72 x 14	SC188571	72 x 24	SC188564
24 x 18	SC188572	36 x 30	SC188540
30 x 18	SC188573	48 x 30	SC188541
36 x 18	SC188550	60 x 30	SC188542
42 x 18	SC188574	72 x 30	SC188543
48 x 18	SC188552	36 x 36	SC188544
54 x 18	SC188337	48 x 36	SC188545
60 x 18	SC188554	60 x 36	SC188546
72 x 18	SC188562	72 x 36	SC188547

"S" HOOK - Package of 12, use two per shelf for each ADD-ON shelf unit. Model SC189372

MORE ACCESSORIES AVAILABLE ONLINE

- FLOOR GLIDES
- UTILITY CART HANDLE
- PLATE CASTERS
- FOOT PLATE
- ESD CONVERSION KIT
- THREE SIDED
- WALL MOUNT KIT
- "S" HOOK
- FRAME
- DOLLY BASE
- ...AND MORE

CHROME WIRE SHELVING

*New Higher Capacity Wire Shelving Holds
Up to 800 Lbs. Per Shelf*

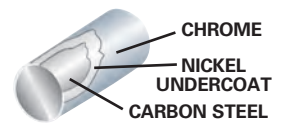

54" HIGH - 4 SHELF

W" x D"	STARTER Model	ADD-ON Model
24 x 14	SC188200	SC188201
30 x 14	SC188202	SC188203
36 x 14	SC188204	SC188205
42 x 14	SC188206	SC188207
48 x 14	SC188208	SC188209
54 x 14	SC188210	SC188211
60 x 14	SC188212	SC188213
72 x 14	SC188214	SC188215
24 x 18	SC188216	SC188217
30 x 18	SC188218	SC188219
36 x 18	SC188220	SC188221
42 x 18	SC188222	SC188223
48 x 18	SC188224	SC188225
54 x 18	SC188226	SC188227
60 x 18	SC188228	SC188229
72 x 18	SC188230	SC188231
24 x 24	SC188232	SC188233
30 x 24	SC188234	SC188235
36 x 24	SC188236	SC188237
42 x 24	SC188238	SC188239
48 x 24	SC188240	SC188241
54 x 24	SC188242	SC188243
60 x 24	SC188244	SC188245
72 x 24	SC188246	SC188247
36 x 30	SC188248	SC188249
48 x 30	SC188250	SC188251
60 x 30	SC188252	SC188253
72 x 30	SC188254	SC188255
36 x 36	SC188256	SC188257
48 x 36	SC188258	SC188259
60 x 36	SC188260	SC188261
72 x 36	SC188262	SC188263

63" HIGH - 4 SHELF

W" x D"	STARTER Model	ADD-ON Model
24 x 14	SC188264	SC188265
30 x 14	SC188266	SC188267
36 x 14	SC184725	SC184761
42 x 14	SC188268	SC188269
48 x 14	SC184726	SC184762
54 x 14	SC188270	SC188271
60 x 14	SC184727	SC184763
72 x 14	SC184728	SC184764
24 x 18	SC188272	SC188273
30 x 18	SC188274	SC188275
36 x 18	SC188400	SC188401
42 x 18	SC188276	SC188277
48 x 18	SC188402	SC188403
54 x 18	SC188278	SC188279
60 x 18	SC188404	SC188405
72 x 18	SC188406	SC188407
24 x 24	SC188280	SC188281
30 x 24	SC188282	SC188283
36 x 24	SC188408	SC188409
42 x 24	SC188284	SC188285
48 x 24	SC188410	SC188411
54 x 24	SC188286	SC188287
60 x 24	SC188412	SC188413
72 x 24	SC188414	SC188415
36 x 30	SC184729	SC184765
48 x 30	SC184730	SC184766
60 x 30	SC184731	SC184767
72 x 30	SC184732	SC184768
36 x 36	SC184733	SC184769
48 x 36	SC184734	SC184770
60 x 36	SC184735	SC184771
72 x 36	SC184736	SC184772



74" HIGH - 4 SHELF

W" x D"	STARTER Model	ADD-ON Model
24 x 14	SC188288	SC188289
30 x 14	SC188290	SC188291
36 x 14	SC184737	SC184773
42 x 14	SC188292	SC188293
48 x 14	SC184738	SC184774
54 x 14	SC188294	SC188295
60 x 14	SC184739	SC184775
72 x 14	SC184740	SC184776
24 x 18	SC188296	SC188297
30 x 18	SC188298	SC188299
36 x 18	SC188420	SC188421
42 x 18	SC188300	SC188301
48 x 18	SC188422	SC188423
54 x 18	SC188302	SC188303
60 x 18	SC188424	SC188425
72 x 18	SC188426	SC188427
24 x 24	SC188304	SC188305
30 x 24	SC188306	SC188307
36 x 24	SC188428	SC188429
42 x 24	SC188308	SC188309
48 x 24	SC188430	SC188431
54 x 24	SC188310	SC188311
60 x 24	SC188432	SC188433
72 x 24	SC188434	SC188435
36 x 30	SC184741	SC184777
48 x 30	SC184742	SC184778
60 x 30	SC184743	SC184779
72 x 30	SC184744	SC184780
36 x 36	SC184745	SC184781
48 x 36	SC184746	SC184782
60 x 36	SC184747	SC184783
72 x 36	SC184748	SC184784

86" HIGH - 4 SHELF

W" x D"	STARTER Model	ADD-ON Model
24 x 14	SC188312	SC188313
30 x 14	SC188314	SC188315
36 x 14	SC184749	SC184785
42 x 14	SC188316	SC188317
48 x 14	SC184750	SC184786
54 x 14	SC188318	SC188319
60 x 14	SC184751	SC184787
72 x 14	SC184752	SC184788
24 x 18	SC188320	SC188321
30 x 18	SC188322	SC188323
36 x 18	SC188440	SC188441
42 x 18	SC188324	SC188325
48 x 18	SC188442	SC188443
54 x 18	SC188326	SC188327
60 x 18	SC188444	SC188445
72 x 18	SC188446	SC188447
24 x 24	SC188328	SC188329
30 x 24	SC188330	SC188331
36 x 24	SC188448	SC188449
42 x 24	SC188332	SC188333
48 x 24	SC188450	SC188451
54 x 24	SC188334	SC188335
60 x 24	SC188452	SC188453
72 x 24	SC188454	SC188455
36 x 30	SC184753	SC184789
48 x 30	SC184754	SC184790
60 x 30	SC184755	SC184791
72 x 30	SC184756	SC184792
36 x 36	SC184757	SC184793
48 x 36	SC184758	SC184794
60 x 36	SC184759	SC184795
72 x 36	SC184760	SC184796



SEE PAGE 16 -- MORE ACCESSORIES AVAILABLE ONLINE

01-800-467-0529

chproductos.com

15

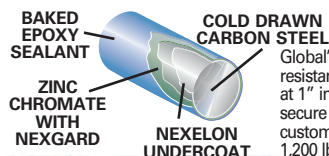

NEXELON WIRE SHELVING

NOW WITH NEXGARD – ANTI-MICROBIAL AGENT FIGHTS AGAINST BACTERIA GROWTH!

Global's premium quality, exclusive Nexelon finished shelves are ideal for any environment, wet or dry, hot or cold; and are wear, impact and chemical resistant. And now they include Nexgard, an anti microbial agent that fights bacteria and mildew growth as well. Units assemble easily and shelves adjust at 1" increments without tools on numbered posts for quick alignment. **Starter Unit** includes 4 posts with leveling feet, 4 shelves and snap-on sleeves to secure shelves to posts. **Add-On Unit** includes 2 posts with leveling feet, 4 shelves, snap-on sleeves and 8 S-hooks. Also available: Individual Shelves to customize your storage (includes snap-on sleeves) and **Shelf Truck** models roll easily on 4 polymer swivel casters, 2 with dual lock (swivel and wheel).

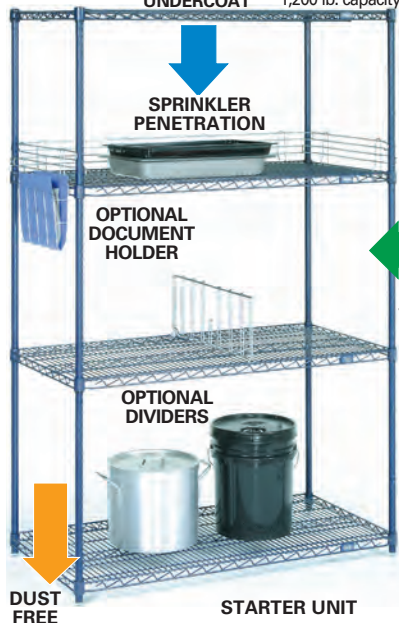

Limited Lifetime Warranty Against Corrosion Perfect for Food Services, Wet Storage and More

OPTIONAL LEDGES

STARTER UNIT
4 posts, 4 shelves and snap sleeves that secure shelf to post.

EXCELLENT VENTILATION

ADD-ON UNIT
2 posts, 4 shelves, snap sleeves and 8 "S" shelf hooks.



Online Video & Photos

MAXIMUM VISIBILITY



W"x D"x H"	STARTER UNIT Model	ADD-ON UNIT Model	TRUCK Model
36 x 18 x 63	SC188400E	SC188401E	SC188820
48 x 18 x 63	SC188402E	SC188403E	SC188822
60 x 18 x 63	SC188404E	SC188405E	SC188824
72 x 18 x 63	SC188406E	SC188407E	SC188826
36 x 24 x 63	SC188408E	SC188409E	SC188828
48 x 24 x 63	SC188410E	SC188411E	SC188830
60 x 24 x 63	SC188412E	SC188413E	SC188832
72 x 24 x 63	SC188414E	SC188415E	SC188834
36 x 18 x 74	SC188420E	SC188421E	SC188840
48 x 18 x 74	SC188422E	SC188423E	SC188842
60 x 18 x 74	SC188424E	SC188425E	SC188844
72 x 18 x 74	SC188426E	SC188427E	SC188846
36 x 24 x 74	SC188428E	SC188429E	SC188848
48 x 24 x 74	SC188430E	SC188431E	SC188850
60 x 24 x 74	SC188432E	SC188433E	SC188852
72 x 24 x 74	SC188434E	SC188435E	SC188854
36 x 18 x 86	SC188440E	SC188441E	SC188860
48 x 18 x 86	SC188442E	SC188443E	SC188862
60 x 18 x 86	SC188444E	SC188445E	SC188864
72 x 18 x 86	SC188446E	SC188447E	SC188866
36 x 24 x 86	SC188448E	SC188449E	SC188868
48 x 24 x 86	SC188450E	SC188451E	SC188870
60 x 24 x 86	SC188452E	SC188453E	SC188872
72 x 24 x 86	SC188454E	SC188455E	SC188874

BUILD YOUR OWN ACCESSORIES

POST includes leveling feet.		ADDITIONAL SHELF*		ADDITIONAL SHELF**	
H"	Model	W" x D"	SHELF*	W" x D"	SHELF**
54	SC188395	36 x 18	SC188550E	36 x 24	SC188556E
63	SC188396	48 x 18	SC188552E	48 x 24	SC188558E
74	SC188397	60 x 18	SC188554E	60 x 24	SC188560E
86	SC188398	72 x 18	SC188562E	72 x 24	SC188564E

*"S" Shelf Hooks Model SC189372B. 2 hooks per shelf required for Add-on units.

LEDGES Chrome. 4" high.

L"	Model	L"	Model	SHELF DIVIDERS Chrome. D" x H"	Model	DOCUMENT HOLDER. 12 3/8" L x 2" W x 8 5/8" H, chrome. Model SC189389
18	SC188580E	48	SC188586E	18 x 8	SC188595E	
24	SC188582E	60	SC188588E	24 x 8	SC188596E	
36	SC188584E	72	SC188590E			

MORE ACCESSORIES AVAILABLE ONLINE

- FLOOR GLIDES
- UTILITY CART HANDLE • PLATE
- FOOT PLATE
- ESD CONVERSION KIT CASTERS
- WALL MOUNT KIT • "S" HOOK
- DOLLY BASE
- THREE SIDED FRAME
- AND MORE



CHROME FINISH CHROME

NICKEL

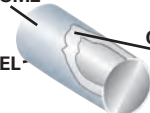

CARBON STEEL



Shelf Hooks Quickly readjust on 1" Numbered Posts



Snap sleeve on 1" increments numbered on post Slide shelf over sleeve for secure, positive locking

QUICK ADJUST WIRE SHELVING

Our unique patented quick adjust suspension hooks allow middle shelves to be adjusted, added or removed without disassembly or tools. Shelves simply lift off hooks and replace in seconds. Wire shelving benefits include minimal dust accumulation, excellent visibility and light, sprinkler and air penetration. Unit includes 4 posts, 2 fixed 600 or 800lb. capacity shelves for top and bottom levels, 2 quick adjust 400 lb. capacity shelves and 8 suspension hooks. All shelves adjust at 1" increments. Genuine chrome plated finish. **Adjust in an Instant!**



2400 lb. unit capacity

W" x D"	Model	Model
54"H SHELF UNIT		
36 x 14	SC580590	74"H SHELF UNIT
48 x 14	SC580591	SC580594
36 x 18	SC580550	SC580595
48 x 18	SC580551	SC580566
60 x 18	SC580552	SC580567
72 x 18	SC580553	SC580568
36 x 24	SC580554	SC580569
48 x 24	SC580555	SC580570
60 x 24	SC580556	SC580571
72 x 24	SC580557	SC580572
		SC580573
63"H SHELF UNIT		
36 x 14	SC580592	86"H SHELF UNIT
48 x 14	SC580593	SC580596
36 x 18	SC580558	SC580597
48 x 18	SC580559	SC580574
60 x 18	SC580560	SC580575
72 x 18	SC580561	SC580576
36 x 24	SC580562	SC580577
48 x 24	SC580563	SC580578
60 x 24	SC580564	SC580579
72 x 24	SC580565	SC580580
		SC580581

POLY-Z-BRITE WIRE SHELVING

NOW WITH NEXGARD – ANTI-MICROBIAL AGENT
FIGHTS AGAINST BACTERIA GROWTH!

The Look of Chrome with Excellent Temperature and Moisture Resistance

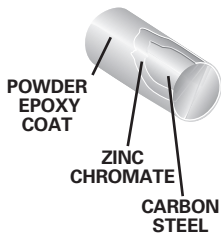

Perfect for
Coolers
and Freezers

Nexel Poly-Z-Brite Wire Shelving. Attractive finish that's guaranteed to last! The Poly-Z-Brite finish of these wire shelves is so tough that we offer a **15 Year Limited Warranty** against rust and corrosion. It combines the attractive look of chrome with a rugged electroplated zinc-chromate epoxy finish, making it perfect for any storage needs including retail display. Open wire design minimizes dust accumulation and maximizes ventilation and visibility. The easy-slide shelf surface makes loading and unloading a snap. Shelves adjust quickly and easily at 1" increments on snap-on sleeves. Easy, tool-free assembly.

Starter Unit includes 4 posts, 4 shelves and snap-on sleeves to secure shelves.

Add-On Unit includes 2 posts, 4 shelves, snap-on sleeves and hooks to join shelves and allows U, T and L shaped configurations.

Shelves up to 42"W have an 800 lb. capacity. Shelves 48"W or more have a 600 lb. capacity per shelf. Easy assembly and adjustment.

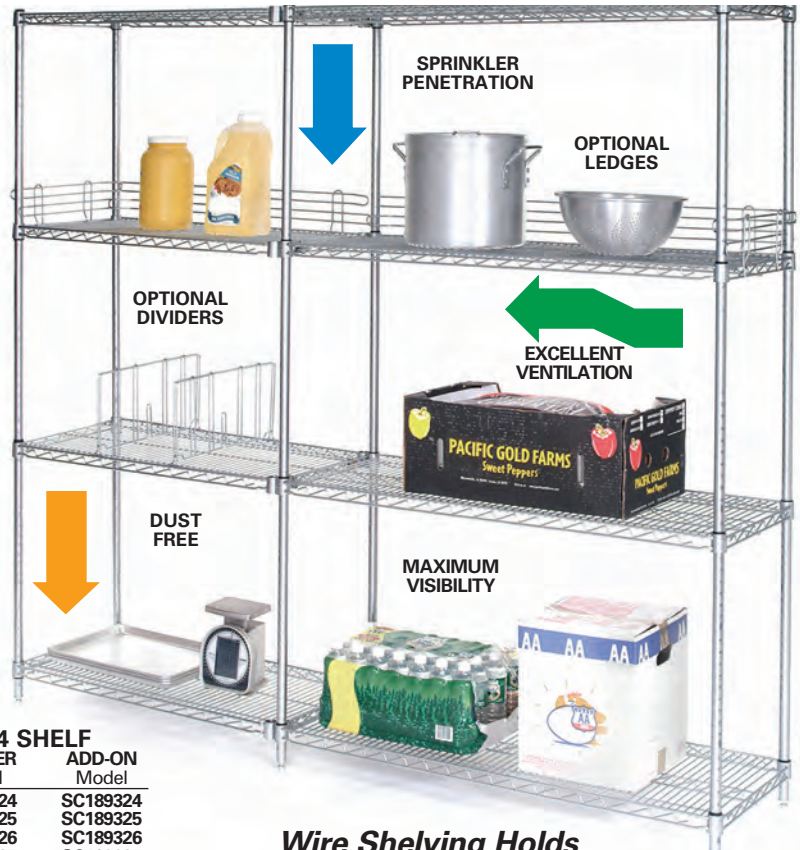

Wire Shelving Holds
Up to 800 Lbs. Per Shelf

EASY ASSEMBLY &
ADJUSTMENT



"S" HOOK

TWO "S" HOOKS CONNECT
ADD-ON SHELF TO
STARTER SHELF



SNAP SLEEVE
AROUND
NUMBERED POST

"S" HOOK - Package of
12, use two per shelf
for each ADD-ON unit.
Model SC189372A



SLIDE SHELF OVER
SLEEVE FOR SECURE,
POSITIVE LOCKING

MORE ACCESSORIES AVAILABLE

- FLOOR GLIDES
- FOOT PLATE
- WALL MOUNT KIT
- UTILITY CART HANDLE
- ESD CONVERSION KIT
- DOLLY BASE
- PLATE CASTERS
- THREE SIDED FRAME
- ...AND MORE

63" HIGH - 4 SHELF

W" x D"	STARTER Model	ADD-ON Model
24 x 18	SC189200	SC189300
30 x 18	SC189201	SC189301
36 x 18	SC189202	SC189302
42 x 18	SC189203	SC189303
48 x 18	SC189204	SC189304
54 x 18	SC189205	SC189305
60 x 18	SC189206	SC189306
72 x 18	SC189207	SC189307
24 x 24	SC189216	SC189316
30 x 24	SC189217	SC189317
36 x 24	SC189218	SC189318
42 x 24	SC189219	SC189319
48 x 24	SC189220	SC189320
54 x 24	SC189221	SC189321
60 x 24	SC189222	SC189322
72 x 24	SC189223	SC189323

74" HIGH - 4 SHELF

W" x D"	STARTER Model	ADD-ON Model
24 x 18	SC189224	SC189324
30 x 18	SC189225	SC189325
36 x 18	SC189226	SC189326
42 x 18	SC189227	SC189327
48 x 18	SC189228	SC189328
54 x 18	SC189229	SC189329
60 x 18	SC189230	SC189330
72 x 18	SC189231	SC189331
24 x 24	SC189240	SC189340
30 x 24	SC189241	SC189341
36 x 24	SC189242	SC189342
42 x 24	SC189243	SC189343
48 x 24	SC189244	SC189344
54 x 24	SC189245	SC189345
60 x 24	SC189246	SC189346
72 x 24	SC189247	SC189347

ACCESSORIES

ADDITIONAL
SHELVES
Model

SC189373
SC189374
SC189375
SC189376
SC189377
SC189378
SC189379
SC189380
SC189381
SC189382
SC189383
SC189384
SC189385
SC189386
SC189387
SC189388

SHELF LEDGE

L" x H"	Chrome Model
18 x 4	SC188580F
24 x 4	SC188582F
30 x 4	SC188583F
36 x 4	SC188584F
42 x 4	SC188585F
48 x 4	SC188586F
54 x 4	SC188589F
60 x 4	SC188588F
72 x 4	SC188590F

SHELF DIVIDERS
Chrome.

D" x H"	Model
18 x 8	SC188595F
24 x 8	SC188596F
30 x 12	SC188598F
36 x 12	SC188599F

NEXEL BLACK EPOXY WIRE SHELVING

NSF Approved & Guaranteed to Perform Against Corrosion for 7 Full Years. In dry storage applications. The unique baked-on process bonds a black epoxy powder coat directly to the steel's surface resulting in an attractive, rugged and affordable shelving unit. These epoxy wire shelves feature a patented truss reinforced design for extra strength and greater capacities. Open shelving permits sprinkler, air and light penetration and minimizes dust accumulation. Shelves easily adjust without tools and align accurately at 1" increments on numbered posts. Easy assembly. **Starter Unit** includes 4 posts with leveling feet, 4 wire shelves and plastic snap on sleeves to secure shelves. **Add-On Unit** includes 2 posts with leveling feet, 4 wire shelves, plastic snap on sleeves and S-hooks to join units.



W" x D" x H"	STARTER UNIT Model	ADD-ON Model	ADDITIONAL SHELF Model
24 x 18 x 63	SCB970147	SCB970143	SCB970193
30 x 18 x 63	SCB970152	SCB970196	SCB970194
36 x 18 x 63	SCB970206	SCB970207	SCB970202
42 x 18 x 63	SCB970157	SCB970149	SCB970210
48 x 18 x 63	SCB970199	SCB970160	SCB970212
54 x 18 x 63	SCB970218	SCB970167	SCB970220
60 x 18 x 63	SCB970162	SCB970177	SCB970144
72 x 18 x 63	SCB970169	SCB970183	SCB970197
24 x 24 x 63	SCB970189	SCB970215	SCB970201
30 x 24 x 63	SCB970213	SCB970209	SCB970203
36 x 24 x 63	SCB970198	SCB970159	SCB970211
42 x 24 x 63	SCB970217	SCB970166	SCB970219
48 x 24 x 63	SCB970156	SCB970173	SCB970221
54 x 24 x 63	SCB970168	SCB970182	SCB970142
60 x 24 x 63	SCB970175	SCB970186	SCB970204
72 x 24 x 63	SCB970180	SCB970188	SCB970205
24 x 18 x 74	SCB970151	SCB970195	SCB970193
30 x 18 x 74	SCB970190	SCB970145	SCB970194
36 x 18 x 74	SCB970214	SCB970208	SCB970202
42 x 18 x 74	SCB970158	SCB970150	SCB970210
48 x 18 x 74	SCB970216	SCB970165	SCB970212
54 x 18 x 74	SCB970155	SCB970172	SCB970220
60 x 18 x 74	SCB970164	SCB970179	SCB970144
72 x 18 x 74	SCB970174	SCB970185	SCB970197
24 x 24 x 74	SCB970191	SCB970146	SCB970201
30 x 24 x 74	SCB970153	SCB970148	SCB970203
36 x 24 x 74	SCB970200	SCB970161	SCB970211
42 x 24 x 74	SCB970154	SCB970171	SCB970219
48 x 24 x 74	SCB970163	SCB970178	SCB970221
54 x 24 x 74	SCB970170	SCB970184	SCB970142
60 x 24 x 74	SCB970176	SCB970187	SCB970204
72 x 24 x 74	SCB970181	SCB970192	SCB970205

NEXEL GREEN EPOXY WIRE SHELVING

Nexel® Green Epoxy Wire Shelving Provides An Attractive Finish That's Guaranteed To Last! The Green Epoxy finish is so tough that we offer a **15 Year Limited Warranty** against rust and corrosion. It features **Nexgard**, an **anti microbial agent** that protects the coating from growth of bacteria, mildew and molds. Shelving is perfect for retail display and can also handle extreme temperatures and moisture making it **ideal for dry storage, coolers and freezers**. Open wire design minimizes dust and maximizes ventilation and visibility. The easy-slide shelf surface makes loading and unloading a snap. Wire shelves adjust at 1" increments. Available in 63" and 74" heights. **Starter Unit** includes 4 posts with leveling feet, 4 wire shelves and plastic snap on sleeves to secure shelves. **Add-On Unit** includes 2 posts with leveling feet, 4 wire shelves, plastic snap on sleeves and S-hooks to join units.



W" x D" x H"	STARTER UNIT Model	ADD-ON Model	ADDITIONAL SHELF Model
24 x 18 x 63	SCB1137264	SCB1137231	SCB1137196
30 x 18 x 63	SCB1137265	SCB1137232	SCB1137197
36 x 18 x 63	SCB1137266	SCB1137233	SCB1137198
42 x 18 x 63	SCB1137271	SCB1137234	SCB1137199
48 x 18 x 63	SCB1137280	SCB1137240	SCB1137200
54 x 18 x 63	SCB1137281	SCB1137241	SCB1137205
60 x 18 x 63	SCB1137282	SCB1137242	SCB1137206
72 x 18 x 63	SCB1137287	SCB1137247	SCB1137207
24 x 24 x 63	SCB1137296	SCB1137248	SCB1137208
30 x 24 x 63	SCB1137297	SCB1137249	SCB1137209
36 x 24 x 63	SCB1137298	SCB1137250	SCB1137222
42 x 24 x 63	SCB1137191	SCB1137255	SCB1137223
48 x 24 x 63	SCB1137210	SCB1137256	SCB1137224
54 x 24 x 63	SCB1137211	SCB1137257	SCB1137225
60 x 24 x 63	SCB1137212	SCB1137258	SCB1137226
72 x 24 x 63	SCB1137213	SCB1137263	SCB1137239
24 x 18 x 74	SCB1137227	SCB1137272	SCB1137196
30 x 18 x 74	SCB1137228	SCB1137273	SCB1137197
36 x 18 x 74	SCB1137229	SCB1137274	SCB1137198
42 x 18 x 74	SCB1137230	SCB1137279	SCB1137199
48 x 18 x 74	SCB1137243	SCB1137288	SCB1137200
54 x 18 x 74	SCB1137244	SCB1137289	SCB1137205
60 x 18 x 74	SCB1137245	SCB1137290	SCB1137206
72 x 18 x 74	SCB1137246	SCB1137295	SCB1137207
24 x 24 x 74	SCB1137259	SCB1137259	SCB1137208
30 x 24 x 74	SCB1137260	SCB1137260	SCB1137209
36 x 24 x 74	SCB1137261	SCB1137261	SCB1137222
42 x 24 x 74	SCB1137262	SCB1137262	SCB1137223
48 x 24 x 74	SCB1137275	SCB1137275	SCB1137224
54 x 24 x 74	SCB1137276	SCB1137276	SCB1137225
60 x 24 x 74	SCB1137277	SCB1137277	SCB1137226
72 x 24 x 74	SCB1137278	SCB1137278	SCB1137239

GALVANIZED AND STAINLESS STEEL SOLID SHELVING

Double walled strong durable shelf perimeter. Raised shelf edge keeps items from rolling off. Leveling feet compensate for uneven floors. Corrosion resistant 18 gauge **GALVANIZED STEEL SHELVES** are coated with a clear epoxy which is temperature and moisture resistant for dry storage coolers and freezers. Type 304 18 gauge **STAINLESS STEEL SHELVES** and posts offer added rust and corrosion resistance. **STARTER UNIT** has 4 posts, 4 shelves and shelf clips. **ADD-ON UNIT** has 2 posts, 4 shelves, and 2 joining clamps per shelf. Easy assembly.

600 lb. shelf capacity

W" x D" x H"	GALVANIZED		ADDITIONAL SHELVES Model
	STARTER UNIT Model	ADD-ON UNIT Model	
36 x 18 x 63	SC189910	SC189920	SC189970
48 x 18 x 63	SC189911	SC189921	SC189971
60 x 18 x 63	SC189912	SC189922	SC189972
72 x 18 x 63	SC189913	SC189923	SC189973
36 x 24 x 63	SC189914	SC189924	SC189974
48 x 24 x 63	SC189915	SC189925	SC189975
60 x 24 x 63	SC189916	SC189926	SC189976
72 x 24 x 63	SC189917	SC189927	SC189977
36 x 18 x 74	SC189930	SC189940	
48 x 18 x 74	SC189931	SC189941	
60 x 18 x 74	SC189932	SC189942	
72 x 18 x 74	SC189933	SC189943	
36 x 24 x 74	SC189934	SC189944	
48 x 24 x 74	SC189935	SC189945	
60 x 24 x 74	SC189936	SC189946	
72 x 24 x 74	SC189937	SC189947	

W" x D" x H"	STAINLESS STEEL		ADDITIONAL SHELVES Model
	STARTER UNIT Model	ADD-ON UNIT Model	
36 x 18 x 63	SC235360	SC235369	SC235387
36 x 24 x 63	SC235361	SC235370	SC235388
48 x 24 x 63	SC235362	SC235371	SC235389
36 x 18 x 74	SC235363	SC235372	SC235387
36 x 24 x 74	SC235364	SC235373	SC235388
48 x 24 x 74	SC235365	SC235374	SC235389
36 x 18 x 86	SC235366	SC235375	SC235387
36 x 24 x 86	SC235367	SC235376	SC235388
48 x 24 x 86	SC235368	SC235377	SC235389



WIRE LEDGES 4" high chrome.	
L"	Model
18	SC189982D
24	SC189983D
30	SC189984D
36	SC189985D
48	SC189986D
60	SC189987D
72	SC189988D

DIVIDERS attach at any point along shelf. 8"H chrome.

L"	Model
18	SC189980
24	SC189981



STEM CASTERS with donut bumper. 200 lb. cap.

Model	Description
SC184835B	5" x 1 1/4" Polyurethane swivel
SC184912B	5" x 1 1/4"-2 with brake

PLASTIC SHELF CLIPS LOCK INTO PLACE ON POSTS FOR QUICK 1" ADJUSTMENT.

STAINLESS STEEL WIRE SHELVING

Limited Lifetime Warranty

These shelf units are constructed to stand the test of time. Stainless steel wire shelving allows for air circulation and functions well in environments with temperature fluctuations. Shelves adjust at 1" increments on numbered posts. Smooth, attractive, electro polished finish over stainless steel provides extra-long life. Stainless Steel handles all moisture and temperature extremes. It resists rust and corrosion and is ideal for any storage requirements. **SHELVING STARTER UNITS** contain four posts, four shelves and snap sleeves that attach shelf to post. **ADD-ON UNITS** consist of two posts, four shelves, snap sleeves and eight "S" attachment hooks. Shelves have up to 800 lb. capacity depending on shelf width. Easy assembly. Limited Lifetime Warranty against rust. For Shelf Truck add suffix "A" to starter model. For casters with wheel brake add "AB".

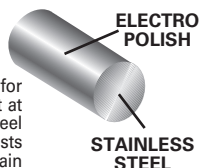

W" x D" x H"	STARTER UNIT Model	ADD-ON UNIT Model	W" x D" x H"	STARTER UNIT Model	ADD-ON UNIT Model
	36 x 18 x 63	SC189400		SC189401	36 x 18 x 74
48 x 18 x 63	SC189402	SC189403	48 x 18 x 74	SC189410	SC189411
54 x 18 x 63	SC189446	SC189447	54 x 18 x 74	SC189486	SC189487
60 x 18 x 63	SC189448	SC189449	60 x 18 x 74	SC189488	SC189489
72 x 18 x 63	SC189450	SC189451	72 x 18 x 74	SC189490	SC189491
36 x 24 x 63	SC189404	SC189405	36 x 24 x 74	SC189412	SC189413
48 x 24 x 63	SC189406	SC189407	48 x 24 x 74	SC189414	SC189415
60 x 24 x 63	SC189476	SC189477	60 x 24 x 74	SC189516	SC189517
72 x 24 x 63	SC189478	SC189479	72 x 24 x 74	SC189518	SC189519

ADDITIONAL SHELVES	
W" x D"	Model
36 x 18	SC189424
48 x 18	SC189425
54 x 18	SC189571
60 x 18	SC189572
72 x 18	SC189573
36 x 24	SC189426
48 x 24	SC189427
60 x 24	SC189593
72 x 24	SC189594

MORE ACCESSORIES AVAILABLE ONLINE

- FLOOR GLIDES
- FOOT PLATE
- WALL MOUNT KIT
- ESD CONVERSION KIT
- DOLLY BASE
- PLATE CASTERS
- THREE SIDED FRAME
- UTILITY CART HANDLE
- ...AND MORE



STARTER UNIT SHOWN WITH OPTIONAL ACCESSORIES
01-800-467-0529

chproductos.com

CUSTOMIZE WITH WIRE ACCESSORIES

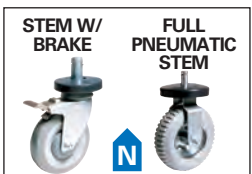
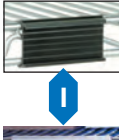
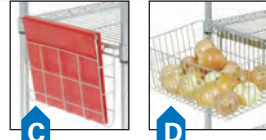
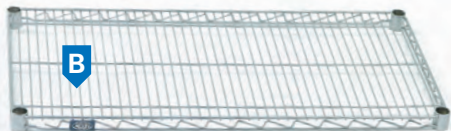

Interchangeable with the Following: METRO, HODGES, EAGLE, ISS

A. POST - Includes leveling feet. Ht. Model

CHROME	
6	SC188459
14	SC188456
34	SC188457
42	SC188499
54	SC188458
63	SC188551
66	SC188855
74	SC188553
86	SC188555
96	SC188557
STAINLESS STEEL	
63	SC235874
74	SC235875
86	SC235876

C. DOCUMENT HOLDER - 12³/₈"L x 2"W x 8⁵/₈"H. Chrome. Model SC489070

D. UTILITY BASKET - 17³/₈"L x 7¹/₂"W x 10"H. Chrome. Model SC184798

E. KEYBOARD DRAWER - Attaches under shelf. Holds keyboards up to 21"W x 11"D. Has 6" height adjustment. 25¹/₄"W x 15"D x 4¹/₄"H. Chrome. Model SC339042

F. SINGLE-BOX SLIDE - Creates a slide out drawer below shelf. Accepts boxes up to 24"D. Model SC339004

G. MULTI-BOX SLIDE - Fits between any two 18" or 24" deep wire shelves spaced 22" apart. Slides spaced on 1¹/₂" centers.

Depth"	Model
18	SC188591
24	SC188592

I. LABEL HOLDER - 1¹/₄"H. Snaps onto shelf. Slide in label. Clear holders include paper inserts. Sold in package quantities.

Model	W"	Color	Pkg. Qty.
SC481132	3	Black	25
SC481133	3	Clear	25
SC481134	12	Clear	12
SC481135	24	Clear	6

B. WIRE SHELVES - adjust on 1" increments, includes shelf sleeves. Shelves up to 42"W have 800 lb. capacity per shelf. 48"W and larger have 600 lb. capacity.

CHROME SHELVES	
W" x D"	Model
24 x 14	SC188565
30 x 14	SC188566
36 x 14	SC188567
42 x 14	SC188568
48 x 14	SC188569
54 x 14	SC188336
60 x 14	SC188570
72 x 14	SC188571

CHROME SHELVES	
W" x D"	Model
36 x 30	SC188540
48 x 30	SC188541
60 x 30	SC188542
72 x 30	SC188543
36 x 36	SC188544
48 x 36	SC188545
60 x 36	SC188546
72 x 36	SC188547

STAINLESS STEEL SHELVES	
W" x D"	Model
36 x 18	SC189424
48 x 18	SC189425
60 x 18	SC189572
72 x 18	SC189573
36 x 24	SC189426
48 x 24	SC189427
60 x 24	SC189593
72 x 24	SC189594

H. SOLID SHELVES W" x D" Model

GALVANIZED	
W" x D"	Model
36 x 18	SC189970
48 x 18	SC189971
60 x 18	SC189972
72 x 18	SC189973
36 x 24	SC189974
48 x 24	SC189975
60 x 24	SC189976
72 x 24	SC189977

I. REPLACEMENT SHELF SLEEVES - Snap on post and slide shelf over for positive locking. Priced at 18 pairs per package. Model SC336374

K. PLASTIC SHELF LINER .035"th. plastic prevents items from falling through wire shelves.

W" x D"	Model
36 x 18	SC188737CL
48 x 18	SC188738CL
60 x 18	SC188739CL
72 x 18	SC188740CL
36 x 24	SC188741CL
48 x 24	SC188742CL
60 x 24	SC188743CL
72 x 24	SC188744CL

K. HARDBOARD SHELF LINER Reversible, black and white. 1/8" thick. Easy to remove and clean.

W" x D"	Model
36 x 18	SC189040
36 x 24	SC189041

L. SHELF LEDGES - for front, back or sides. Prevents items from falling off. Chrome.

L" x H"	FOR WIRE SHELF	FOR SOLID SHELF
	Model	Model
14 x 4	SC188561	----
18 x 4	SC188580	SC189982
21 x 4	SC188581	----
24 x 4	SC188582	SC189983
30 x 4	SC188583	SC189984
36 x 4	SC188584	SC189985
42 x 4	SC188585	----
48 x 4	SC188586	SC189986
54 x 4	SC188589	----
60 x 4	SC188588	SC189987
72 x 4	SC188590	SC189988

M. SHELF DIVIDERS - Attaches at any point along shelf. Chrome.

L" x H"	FOR WIRE SHELF	FOR SOLID SHELF
	Model	Model
14 x 8	SC188563	----
18 x 8	SC188595	SC189980
21 x 8	SC188594	----
24 x 8	SC188596	SC189981
30 x 12	SC188598	----
36 x 12	SC188599	----

N. CASTERS - Mobilize your shelving. STEM SWIVEL CASTERS - Includes donut bumper.

D" x W"	Description	Cap. Lbs.	Model
5 x 1 ¹ / ₄	Polyurethane swivel	1200	SC184835
5 x 1 ¹ / ₄	Polyurethane swivel 2 w/brake	1200	SC184912
8 x 2.80	Full-pneumatic non-marring	1000	SC184938

O. NYLON COVERS - Keep items free of dust and dirt. Made of water resistant 400 denier blue nylon. Two clear pockets hold 8¹/₂" x 11" documents. Simple hook and loop closure.

W" x D"	3" High	74" High
	Model	Model
36 x 18	SC188371BL	SC188379BL
48 x 18	SC188372BL	SC188380BL
60 x 18	SC188373BL	SC188381BL
72 x 18	SC188374BL	SC188382BL
36 x 24	SC188375BL	SC188383BL
48 x 24	SC188376BL	SC188384BL
60 x 24	SC188377BL	SC188385BL
72 x 24	SC188378BL	SC188386BL

MORE ACCESSORIES AVAILABLE ONLINE

- FLOOR GLIDES
- FOOT PLATE
- WALL MOUNT KIT
- UTILITY CART HANDLE
- ESD CONVERSION KIT
- "S" HOOK
- DOLLY BASE
- PLATE CASTERS
- THREE SIDED FRAME
- ...AND MORE

WALL MOUNT WIRE SHELVING

Wall Mount Adjustable Wire Shelving Units are ideal for storing products where floor space is limited. Great for kitchens, restaurants, labs, garages, or any secure wall area. Choose from one, two three or four level units. Each unit includes Mounting Posts, Brackets, Shelves and Hardware in a durable bright chrome finish. Purchase a "Starter" unit and then attach as many "Add-On" units as needed.



W x D x H	Levels	STARTER Model	ADD-ON Model	ADDL. LEVEL Model
36 x 18 x 14	1	SCB1137016	SCB1137024	SCB1137032
48 x 18 x 14	1	SCB1137018	SCB1137026	SCB1136980
48 x 24 x 14	1	SCB1136988	SCB1136975	SCB1137175
60 x 24 x 14	1	SCB1136990	SCB1136977	SCB1137177
36 x 18 x 34	2	SCB1137119	SCB1137127	SCB1137032
48 x 18 x 34	2	SCB1137121	SCB1137129	SCB1136980
48 x 24 x 34	2	SCB1137149	SCB1137165	SCB1137175
60 x 24 x 34	2	SCB1137151	SCB1137135	SCB1137177
36 x 18 x 54	3	SCB1137071	SCB1137083	SCB1137032
48 x 18 x 54	3	SCB1137073	SCB1137085	SCB1136980
48 x 24 x 54	3	SCB1137093	SCB1137047	SCB1137175
60 x 24 x 54	3	SCB1137041	SCB1137052	SCB1137177
36 x 18 x 63	4	SCB1137097	SCB1136996	SCB1137032
48 x 18 x 63	4	SCB1137103	SCB1136998	SCB1136980
48 x 24 x 63	4	SCB1137147	SCB1137163	SCB1137175
60 x 24 x 63	4	SCB1137153	SCB1137170	SCB1137177

Open front, 3-sided frame that allows easy cleaning. Includes a removable wire top deck, frame reinforcement and post caps. 14" High. Nexelon anti-microbial powder epoxy finish fights growth of bacteria and molds with a Limited Lifetime Warranty against corrosion.

W" x D"	Cap. Lbs.	Model
36 x 18	1200	SC561954
48 x 18	1300	SC561955
60 x 18	1000	SC561956
36 x 24	1600	SC561959
48 x 24	1300	SC561960
60 x 24	1000	SC561961

HEAVY DUTY DUNNAGE RACKS



HEAVY DUTY WIRE DECK SHELVING



Up to 1600 lb. capacity



SC653256

Permits sprinkler, air and light penetration and minimizes dust accumulation. Includes 4 posts with leveling feet. Height adjustable shelves easily adjust without tools on numbered posts at 1" increments. Includes 4 shelves and snap-on sleeves. Nexelon anti microbial powder epoxy finish fights growth of bacteria and molds with a Limited Lifetime Warranty against corrosion. NSF approved.

W" x D"	Cap. Lbs	63" HIGH Model	74" HIGH Model	ADDL. SHELVES Model
36 x 18	1600	SC653250	SC653256	SC653262
48 x 18	1300	SC653251	SC653257	SC653263
60 x 18	1000	SC653252	SC653258	SC653264
36 x 24	1600	SC653253	SC653259	SC653265
48 x 24	1300	SC653254	SC653260	SC653266
60 x 24	1000	SC653255	SC653261	SC653267

SPACE-TRAC HIGH DENSITY MOBILE STORAGE

Double your storage capacity using minimal space. Provide instant access to inventory while freeing floor space. Ideal for dry storage, coolers and walk-in freezers. Utilizes 2 stationary shelving units (one for each end) connected with an overhead track to allow mobile shelving units in between to smoothly shift side-to-side. Includes two 12'L stainless steel tracks. Each shelving unit includes 4 height adjustable shelves at 1" increments. Open wire shelves allow air, light and sprinkler penetration while minimizing dust accumulation. Each Mobile Unit includes (4) 5" polyurethane casters. Chrome features an electro-plated nickel-chrome finish for a brilliant high gloss. Poly-Z-Brite™ offers a 10-year limited warranty against rust. Powder-epoxy over zinc-chromate electroplating resembles the look of chrome, but handles extreme temperatures and moisture. Assembly required.

W" x D" x H"	SHELF UNITS		CHROME Model	POLY-Z-BRITE Model
	Stationary	Mobile		
36 x 18 x 74	2	4	SC795976	SC795988
48 x 18 x 74	2	4	SC795977	SC795989
36 x 21 x 74	2	3	SC795978	SC795990
48 x 21 x 74	2	3	SC795979	SC795991
36 x 24 x 74	2	2	SC795980	SC795992
48 x 24 x 74	2	2	SC795981	SC795993
36 x 18 x 86	2	4	SC795982	SC795994
48 x 18 x 86	2	4	SC795983	SC795995
36 x 21 x 86	2	3	SC795984	SC795996
48 x 21 x 86	2	3	SC795985	SC795997
36 x 24 x 86	2	2	SC795986	SC795998
48 x 24 x 86	2	2	SC795987	SC795999



TOP VIEW SC795978

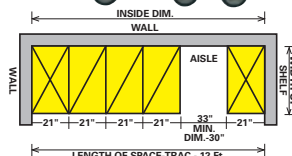

HEAVY DUTY 18 & 20 GAUGE INDUSTRIAL STEEL SHELVING

At Discount Prices

- X-Shaped Anti-Sway Braces Increase Rigidity And Provide More Support On Uneven Floors Than Regular Lateral Braces
- Braces Cover Perimeter Of Rack Instead Of Aligning At Just One Point

Customized to your special needs at no extra cost, heavy duty steel shelving units have been engineered to adapt to your storage requirements. Ideal for stockroom, factory or office where extra storage space is needed. Roll-formed steel ribbed shelves with integral box beam reinforced front and rear edges for greater load capacity. Shelves easily adjustable on 1" centers. Rib-reinforced 14 gauge 1" x 2" steel posts. Phosphatized to prevent corrosion, give maximum paint adhesion. Finished in long lasting gray baked-on enamel.

Shelf Size"	SHELF LOAD CAPACITIES					
	No Reinforcement		With Reinforcement		With 2 Reinforcements	
	Capacity	Lbs.	Capacity	Lbs.	Capacity	Lbs.
36 x 12	775	975	875	1175	1025	1400
36 x 18	750	1050	900	1250	1075	1500
36 x 24	775	1100	925	1300	1125	1575
36 x 30	785	1110	935	1310	1135	1585
48 x 12	525	600	625	700	750	825
48 x 18	540	650	650	775	775	925
48 x 24	550	700	675	850	800	1000
48 x 30	560	710	685	860	810	1010

Consists of 4 posts, specified number of shelves, 4 clips per shelf, 1 pair back braces, 2 pair of side braces and necessary nuts and bolts.

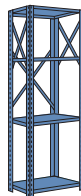

73" HIGH (6'1") 20 GAUGE 18 GAUGE 4 SHELVES

W" x D"	Model	Model
36 x 12	SC234000A	SC562150A
36 x 18	SC234004A	SC562151A
36 x 24	SC234008A	SC562152A
36 x 30	SC234012A	SC562153A
48 x 12	SC234032A	SC562154A
48 x 18	SC234036A	SC562155A
48 x 24	SC234040A	SC562156A
48 x 30	SC234044A	SC562157A

5 SHELVES

W" x D"	Model	Model
36 x 12	SC234064A	SC562158A
36 x 18	SC234068A	SC562159A
36 x 24	SC234072A	SC562160A
36 x 30	SC234076A	SC562161A
48 x 12	SC234096A	SC562162A
48 x 18	SC234100A	SC562163A
48 x 24	SC234104A	SC562164A
48 x 30	SC234108A	SC562165A

6 SHELVES

W" x D"	Model	Model
36 x 12	SC234128A	SC562166A
36 x 18	SC234132A	SC562167A
36 x 24	SC234136A	SC562168A
36 x 30	SC234140A	SC562169A
48 x 12	SC234160A	SC562170A
48 x 18	SC234164A	SC562171A
48 x 24	SC234168A	SC562172A
48 x 30	SC234172A	SC562173A

7 SHELVES

W" x D"	Model	Model
36 x 12	SC234129A	SC562174A
36 x 18	SC234131A	SC562175A
36 x 24	SC234133A	SC562176A
36 x 30	SC234135A	SC562177A
48 x 12	SC234137A	SC562178A
48 x 18	SC234139A	SC562179A
48 x 24	SC234141A	SC562180A
48 x 30	SC234143A	SC562181A

85" HIGH (7'1") 20 GAUGE 18 GAUGE 4 SHELVES

W" x D"	Model	Model
36 x 12	SC234192A	SC562182A
36 x 18	SC234196A	SC562183A
36 x 24	SC234200A	SC562184A
36 x 30	SC234204A	SC562185A
48 x 12	SC234224A	SC562186A
48 x 18	SC234228A	SC562187A
48 x 24	SC234232A	SC562188A
48 x 30	SC234236A	SC562189A

5 SHELVES

W" x D"	Model	Model
36 x 12	SC234191A	SC562190A
36 x 18	SC234193A	SC562191A
36 x 24	SC234195A	SC562192A
36 x 30	SC234197A	SC562193A
48 x 12	SC234199A	SC562194A
48 x 18	SC234201A	SC562195A
48 x 24	SC234203A	SC562196A
48 x 30	SC234205A	SC562197A

6 SHELVES

W" x D"	Model	Model
36 x 12	SC234256A	SC562198A
36 x 18	SC234260A	SC562199A
36 x 24	SC234264A	SC562200A
36 x 30	SC234268A	SC562201A
48 x 12	SC234278A	SC562202A
48 x 18	SC234282A	SC562203A
48 x 24	SC234286A	SC562204A
48 x 30	SC234290A	SC562205A

7 SHELVES

W" x D"	Model	Model
36 x 12	SC234310A	SC562206A
36 x 18	SC234314A	SC562207A
36 x 24	SC234318A	SC562208A
36 x 30	SC234342A	SC562210A
48 x 18	SC234342A	SC562210A
48 x 18	SC234346A	SC562211A
48 x 24	SC234350A	SC562212A
48 x 30	SC234354A	SC562213A

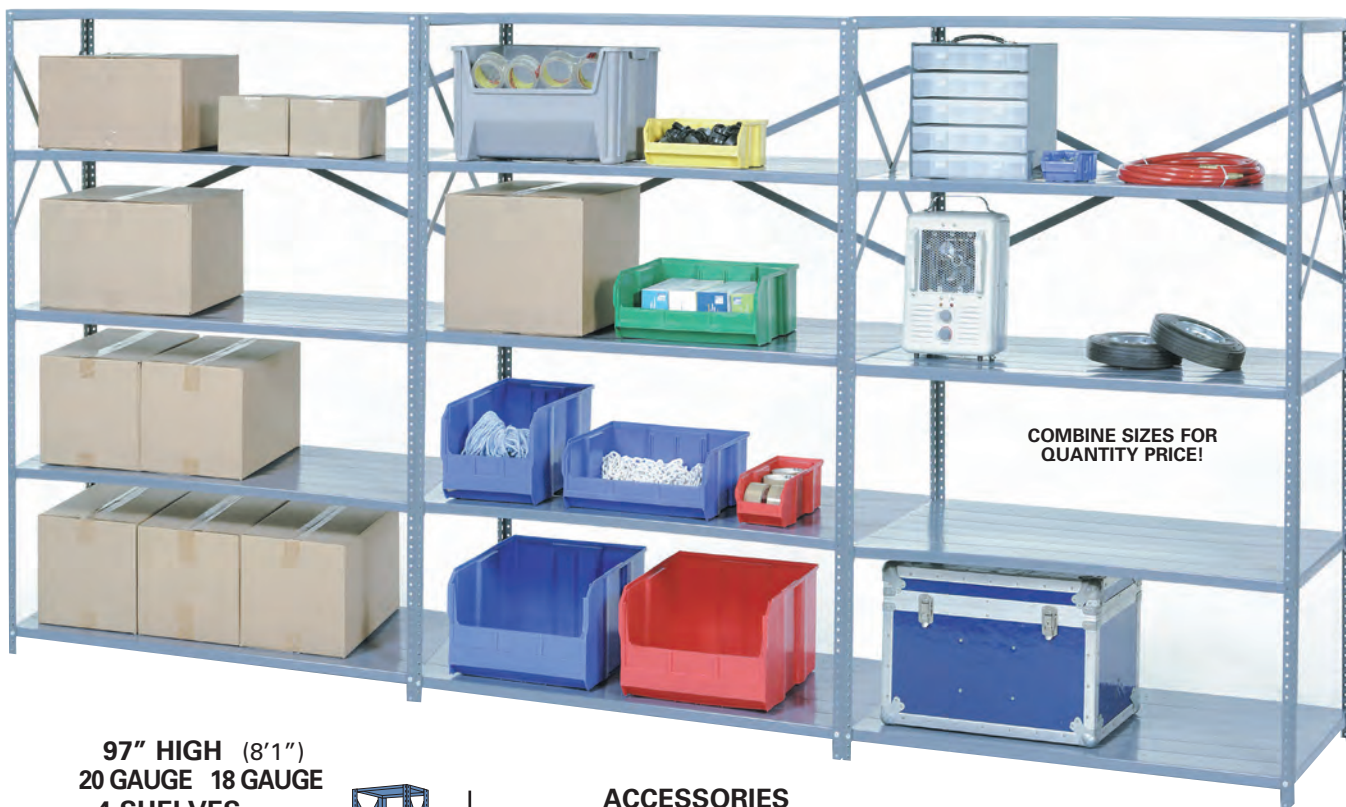

COMBINE SIZES FOR QUANTITY PRICE!

97" HIGH (8'1")
20 GAUGE 18 GAUGE
4 SHELVES

W" x D"	Model	Model
36 x 12	SC234363A	SC562214A
36 x 18	SC234367A	SC562215A
36 x 24	SC234371A	SC562216A
36 x 30	SC234375A	SC562217A
48 x 12	SC234381A	SC562218A
48 x 18	SC234385A	SC562219A
48 x 24	SC234389A	SC562220A
48 x 30	SC234393A	SC562221A

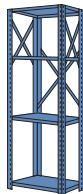

5 SHELVES

W" x D"	Model	Model
36 x 12	SC234374A	SC562222A
36 x 18	SC234378A	SC562223A
36 x 24	SC234382A	SC562224A
36 x 30	SC234386A	SC562225A
48 x 12	SC234406A	SC562226A
48 x 18	SC234410A	SC562227A
48 x 24	SC234414A	SC562228A
48 x 30	SC234418A	SC562229A

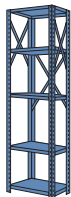

6 SHELVES

W" x D"	Model	Model
36 x 12	SC234438A	SC562230A
36 x 18	SC234442A	SC562231A
36 x 24	SC234446A	SC562232A
36 x 30	SC234450A	SC562233A
48 x 12	SC234470A	SC562234A
48 x 18	SC234474A	SC562235A
48 x 24	SC234478A	SC562236A
48 x 30	SC234482A	SC562237A

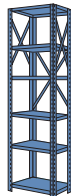

7 SHELVES

W" x D"	Model	Model
36 x 12	SC234502A	SC562238A
36 x 18	SC234506A	SC562239A
36 x 24	SC234510A	SC562240A
36 x 30	SC234514A	SC562241A
48 x 12	SC234534A	SC562242A
48 x 18	SC234538A	SC562243A
48 x 24	SC234542A	SC562244A
48 x 30	SC234546A	SC562245A



ACCESSORIES

SHELVES - Steel, box-formed on front and rear for added strength and safety. Shelves are punched on 2" centers for divider adjustment. Includes shelf clips.

W" x D"	20 GAUGE SHELF		18 GAUGE SHELF	
	Model	Model	Model	Model
36 x 12	SC234049	SC254242		
36 x 18	SC234051	SC254243		
36 x 24	SC234053	SC254244		
36 x 30	SC234055	SC254245		
48 x 12	SC234057	SC254246		
48 x 18	SC234059	SC254247		
48 x 24	SC234061	SC254248		
48 x 30	SC234063	SC254249		

UPRIGHT POST- Heavy duty 14 gauge 1" x 2" roll-formed post, punched on 1" centers for easy adjustment. Package of 4 includes anti-sway braces, nuts and bolts.

Height"	Model	Height"	Model
39	SC254302	---	---
63	SC254303	85	SC254305
73	SC254304	97	SC254306

UNIVERSAL BRACE KIT - Contains 1 pair back anti-sway and 2 pair side anti-sway braces. Model **SC254405**

EXTRA NUTS AND BOLTS - Secure shelves, braces and panels.
 25 Sets **SC234070**



OPTIONAL LABEL HOLDER



QUAD CLIP
HEAVY DUTY wedge action suspension clip for the ultimate load bearing capability.

EXTRA SHELF CLIP
 (pkg. of 4)
 Model **SC234071A**

HOLDEX LABEL HOLDER. Identify inventory and designated supply areas. Reusable clear plastic strips with paper inserts allow you to relabel quickly and easily. Self Adhesive style adheres to any clean surface, while magnetic strips are for use with steel surfaces. Packaged 12 label holders per box.

Model	W" x H"	Model
SC952000	6 x 3/4	SC952002
SC952003	6 x 1	SC952004
SC952072	6 x 2	SC952067

NEED HELP? WE CAN CUSTOMIZE YOUR SHELVING REQUIREMENTS!

Simply send us a rough sketch or blueprint and our experienced staff will plan your shelving at no extra cost.

MORE ACCESSORIES AVAILABLE ONLINE

- END & BACK PANELS • BASE STRIP • BIN FRONT
- FRAMED HINGED DOOR • SHELF DRAWER & DIVIDER ...AND MORE

HEAVY DUTY 18 & 20 GAUGE CLOSED INDUSTRIAL STEEL SHELVING



STARTER

ADD-ON



QUAD HEAVY DUTY WEDGE ACTION SUSPENSION CLIP

EXTRA SHELF CLIP
Model SC234071B



PLASTIC SHELF DIVIDERS

Divide shelves into separate compartments for multi-item storage. Adjustable on 2" centers. Divider height is the distance between the center of one shelf to the center of the next.

D"x H"	Model
12 x 6	SC235025
12 x 9	SC235027
12 x 12	SC235029
18 x 6	SC235031
18 x 9	SC235033
18 x 12	SC235035

Roll-formed, ribbed shelves have box beam reinforced edges for increased capacities. Quad clip safely secures shelves to uprights and adjusts on 1" centers. 14 ga. steel uprights. Closed side and back panels retain loads. Gray baked enamel with anticorrosion undercoat. **STARTER UNIT** includes 4 uprights, 5 shelves, 4 quad clips per shelf, 1 back and 2 side panels plus all required nuts and bolts. **ADD-ON UNIT** includes 4 uprights, 5 shelves, 4 quad clips per shelf, 1 back and 1 side panels plus all required nuts and bolts.

Shelf Size"	SHELF LOAD CAPACITIES					
	No Reinforcement Capacity Lbs.		With Reinforcement Capacity Lbs.		With 2 Reinforcements Capacity Lbs.	
	20 ga.	18 ga.	20 ga.	18 ga.	20 ga.	18 ga.
36 x 12	775	975	875	1175	1025	1400
36 x 18	750	1050	900	1250	1075	1500
36 x 24	775	1100	925	1300	1125	1575
36 x 30	785	1110	935	1310	1135	1585
48 x 12	525	600	625	700	750	825
48 x 18	540	650	650	775	775	925
48 x 24	550	700	675	850	800	1000
48 x 30	560	710	685	860	810	1010

MORE ACCESSORIES AVAILABLE ONLINE

- END & BACK PANELS • EXTRA NUTS & BOLTS
- UNIVERSAL BRACE KIT • BASE STRIP • BIN FRONT
- FRAMED HINGED DOOR • SHELF DRAWER & DIVIDER
- ...AND MORE

ALL UNITS INCLUDE 5 SHELVES

73" HIGH CLOSED TYPE (6'1"H)

W" x D"	20 GA. STARTER UNIT	20 GA. ADD-ON UNIT	18 GA. STARTER UNIT	18 GA. ADD-ON UNIT
	Model	Model	Model	Model
36 x 12	SC236064A	SC236066A	SC236700	SC236800
36 x 18	SC236068A	SC236070A	SC236702	SC236802
36 x 24	SC236072A	SC236074A	SC236704	SC236804
36 x 30	SC236076A	SC236078A	SC236706	SC236806
48 x 12	SC236096A	SC236098A	SC236708	SC236808
48 x 18	SC236100A	SC236102A	SC236710	SC236810
48 x 24	SC236104A	SC236106A	SC236712	SC236812
48 x 30	SC236108A	SC236110A	SC236714	SC236814

85" HIGH CLOSED TYPE (7'1"H)

W" x D"	20 GA. STARTER UNIT	20 GA. ADD-ON UNIT	18 GA. STARTER UNIT	18 GA. ADD-ON UNIT
	Model	Model	Model	Model
36 x 12	SC236191A	SC236193A	SC236716	SC236816
36 x 18	SC236195A	SC236197A	SC236718	SC236818
36 x 24	SC236201A	SC236205A	SC236720	SC236820
36 x 30	SC236203A	SC236207A	SC236722	SC236822
48 x 12	SC236223A	SC236225A	SC236724	SC236824
48 x 18	SC236227A	SC236229A	SC236726	SC236826
48 x 24	SC236233A	SC236231A	SC236728	SC236828
48 x 30	SC236237A	SC236235A	SC236730	SC236830

97" HIGH CLOSED TYPE (8'1"H)

W" x D"	20 GA. STARTER UNIT	20 GA. ADD-ON UNIT	18 GA. STARTER UNIT	18 GA. ADD-ON UNIT
	Model	Model	Model	Model
36 x 12	SC796376	SC796384	SC796392	SC796400
36 x 18	SC796377	SC796385	SC796393	SC796401
36 x 24	SC796378	SC796386	SC796394	SC796402
36 x 30	SC796379	SC796387	SC796395	SC796403
48 x 12	SC796380	SC796388	SC796396	SC796404
48 x 18	SC796381	SC796389	SC796397	SC796405
48 x 24	SC796382	SC796390	SC796398	SC796406
48 x 30	SC796383	SC796391	SC796399	SC796407

EXTRA HEAVY DUTY DIE RACK SHELVING

3000 lb. shelf capacity

Up to 15,000 Lb.
Capacity Shelving

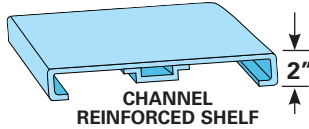

These 14 gauge steel shelves hold heavy items such as jigs, fixtures, dies, and more. Rigid 2" x 2", 14 gauge angle posts. Reinforced shelves with flanged channel construction are adjustable on 1" increments. 3,000 lb. shelf capacity. Gray enamel finish. Easy assembly.

For Additional Models Visit globalindustrial.com

W"x D"	3' HIGH 3 SHELF UNIT Model	5' HIGH 4 SHELF UNIT Model	6' HIGH 5 SHELF UNIT Model	8' HIGH 6 SHELF UNIT Model	ADDITIONAL SHELF Model
36 x 18	SC968600	SC968720	SC236602	SC236632	SC236662
48 x 18	SC968601	SC968721	SC236606	SC236636	SC236666
60 x 18	SC968602	SC968722	SC236608	SC236638	SC236668
36 x 24	SC968603	SC968723	SC236610	SC236640	SC236670
48 x 24	SC968604	SC968724	SC236614	SC236644	SC236674
60 x 24	SC968605	SC968725	SC236616	SC236646	SC236676
72 x 24	SC968606	SC968726	SC236618	SC236648	SC236678



BOLTLESS HEAVY DUTY SHELVING

4000 lb.
Capacity
per Shelf



Extra strength boltless shelving units withstand dies, fixtures, jigs and other heavy material. Made using heavy duty steel with a powder coat finish. 16 gauge steel shelves are reinforced with 14 gauge double rivet steel beams for maximum strength. Includes 5 height adjustable shelves that adjust at 1 1/2" increments. 14-gauge formed angle uprights provide strength and rigidity. Boltless shelving is easy to assemble without the use of nuts, bolts or tools.

W"x D"	Cap. Lbs.	7' HIGH Model	W" x D"	Cap. Lbs.	8' HIGH Model
36 x 18	4000	SC246301	36x18	4000	SC246309
48 x 18	4000	SC246302	48x18	4000	SC246310
48 x 24	4000	SC246303	48x24	4000	SC246311
60 x 24	3250	SC246304	60x24	3250	SC246312
72 x 24	2750	SC246305	72x24	2750	SC246313
96 x 24	2600	SC246307	96x24	2600	SC246315
72 x 36	2750	SC246306	72x36	2750	SC246314
96 x 36	2600	SC246308	96x36	2600	SC246316

"BUILD YOUR OWN" EXTRA HIGH STEEL SHELVING

Customize to your storage needs. Order a minimum of 2 side by side shelving units for stability. Start with 2 upright assemblies, rear sway braces for stability and desired amount of shelves for storage. Add 1 additional upright assembly; add sway braces and shelves for each shelving unit until overall desired width is met. Epoxy coat sand finish. **Upright Assembly** includes two 16 gauge steel posts with 18 gauge anti-sway side braces. Uprights greater than 8'H include 2 anti-sway braces. Allows shelf height adjustments at 2" increments. 18 gauge **Rear Sway Braces** are riveted together in center for added rigidity. 2 or more pairs of rear braces are required for units over 8'H. 22 gauge welded **Steel Shelves** offer 500 lb. capacity and are box formed for added strength. Choose **Plain shelves** with a solid surface or **Perforated shelves** to allow light, air and sprinkler penetration.

UPRIGHT ASSEMBLY

H'	Model
7	SC968611
8	SC968612
10	SC968613
12	SC968614
14	SC968615
16	SC968616

Up To
16' High



SHELF: Specify Solid (S) or Perforated (P) Suffix

W"x D"	Model	SHELVES		REAR SWAY BRACE	
		(S) SOLID Cap. lbs.	(P) PERFORATED Cap. Lbs.	W"	Model
36 x 12	SC968617	750	550	36	SC968629
36 x 18	SC968618	750	550	48	SC968630
36 x 24	SC968619	700	525	---	---
48 x 12	SC968620	500	375	---	---
48 x 18	SC968621	500	375	---	---
48 x 24	SC968622	450	335	---	---



NEXEL SOLID PLASTIC SHELVING

With Poly-Z-Brite Steel Posts

This shelving is ideal for freezers and other wet, cold environments. Sturdy steel frame supports up to 300 lbs. per shelf and includes a Poly-Z-Brite™ finish with a 15 Year Limited Warranty against rust and corrosion. This Plastic Shelving is easy to clean and includes a raised edge to prevent spills. Each shelf adjusts at 1" increments on numbered posts for accurate alignment. Includes 4 upright posts and 4 shelves. Easy tool-free assembly.

W" x D" x H"	COMPLETE UNIT Model	ADDITIONAL SHELVES Model
36 x 18 x 63	SC188124	SC188128
48 x 24 x 63	SC188125	SC188129
36 x 18 x 74	SC188126	SC188128
48 x 24 x 74	SC188127	SC188129

SLANT SHELF MERCHANDISER AND DISPLAYER



SC504128 WITH OPTIONAL RETAINERS AND LABEL HOLDERS



SC504108 WITH OPTIONAL RETAINERS AND LABEL HOLDERS

Overall W" x D" x H"

Model
4 SHELF UNIT
36 x 18 x 63 SC504100
48 x 18 x 63 SC504101
36 x 24 x 63 SC504102
48 x 24 x 63 SC504103

Overall W" x D" x H"

Model
5 SHELF UNIT with Flat Top Shelf
36 x 18 x 54 SC504124
48 x 18 x 54 SC504125
36 x 24 x 54 SC504126
48 x 24 x 54 SC504127
36 x 18 x 63 SC504128
48 x 18 x 63 SC504129
36 x 24 x 63 SC504130
48 x 24 x 63 SC504131
36 x 18 x 74 SC504132
48 x 18 x 74 SC504133
36 x 24 x 74 SC504134
48 x 24 x 74 SC504135

Slanted shelving allows maximum visibility and easy access. Rear loading assures stock rotation. 400 lb. capacity shelves adjust on 1" increments. SHELF UNIT has a 1600 lb. capacity. SHELF TRUCK includes 4 slanted shelves, 2 - 54" front and 2 - 63" rear posts. 1200 lb. capacity, 1600 lb. capacity with Dolly Base. Genuine chrome plating. Easy assembly.

ACCESSORIES	
D" x H"	Model
ADDITIONAL SHELVES	
36 x 18	SC504139
48 x 18	SC504140
36 x 24	SC504141
48 x 24	SC504142
D" x H"	Model
RETAINER/DIVIDER	
18 x 4	SC504136
24 x 4	SC504137
Snap-On LABEL HOLDER	
3"W x 1 1/4"H. Pkg. of 25.	Model SC504138

Overall W" x D" x H"

Model
4 SHELF TRUCK
5" x 1 1/4" Swivel Polyurethane Caster*
36 x 18 x 69 SC504104
48 x 18 x 69 SC504105
36 x 24 x 69 SC504106
48 x 24 x 69 SC504107
Dolly Base 6" x 2" Rubber Tired Caster
36 x 18 x 70 SC504108
48 x 18 x 70 SC504109
36 x 24 x 70 SC504110
48 x 24 x 70 SC504111

*For optional brake casters add "B" to Shelf Truck model number. Set includes 2 swivel and 2 with brakes.

SPACE SAVER GRID WALL PANEL

Put Unused Wall Space to Work



Panels can be mounted on the wall to customize to your needs and utilize wall space. Made of strong 1/4" thick steel wire with 3" square openings. Gray epoxy finish. Mounts to wall using Wall Brackets with 1 1/2" offset (sold separately). Steel and Wire Accessories have an attractive chrome plated finish. 72-piece Hardware Kit includes 6 (B) wall brackets, six (C) 24"W 7-hook tool rails (not shown) and 60 total (D) peg hooks of assorted lengths (12 of each size).

Description	W" x D" x H"	Model	Pkg Qty.
A Grid Wall Panel	48 x 24	SC962700	1
	48 x 36	SC962701	1
	48 x 48	SC962702	1
	60 x 24	SC962703	1
	60 x 36	SC962708	1
	60 x 48	SC962704	1
	72 x 24	SC962705	1
	72 x 36	SC962706	1
72 x 48	SC962707	1	
B Grid Wall Bracket	3 x 1 1/2 x 3	SC331325	6
C 5 Hook Tool Rail	24 x 5	SC331332	6
		SC331333	6
D Peg Hook	4	SC331327	12
		SC331328	12
		SC331329	12
		SC331330	12
E Document Holder	12 3/8 x 2 x 8 5/8	SC489070G	1
	Utility Basket (not shown)	17 3/8 x 7 1/2 x 10	SC184798C
F Extra Shelf Bracket	12	SC331326	6
G Bin Rail	24 x 3 1/4	SC331511	1
		SC331512	1
		SC331513	1
H Plastic Bins	4 1/8 x 5 1/2 x 3	SC331515*	24
		SC331516*	24
		SC331517*	24
* Add Suffix for color: (YL) Yellow, (BL) Blue, (RD) Red.			
J Single Hook	3 1/2	SC331378	12
		Double Hook	3 1/2
L Wire Bins	36 x 14 x 9	SC331371C	1
		SC331372C	1
M Wire Bin Dividers	14 x 9	SC832138C	1
N Wire Shelf	36 x 12	SC331399	3
		SC331400	2
P Wire Shelf with Shelf Ledge	16 3/4 x 16 3/4	SC331591	1
		72 Piece Hardware Kit (Not Shown)	SC331390

ADJUSTABLE BIN PICK RACK & TRUCK

High visibility and quick retrieval make parts picking and inventory control easy. Attractive enough for merchandise display, yet durable enough for warehouse. Chrome plated wire construction reduces dust accumulation and allows air to circulate. **Bins have a 125 lb. capacity each and can be angled up, down, flat or any combination.** 600 to 800 lb. capacity wire shelves on top and bottom for added storage. **Mobile** rack has 800 lb. capacity. Add 6" for overall height with casters. 5" poly wheel stem casters (2 locking). **Easy assembly.**

3 WAYS TO ASSEMBLE: BINS ADJUST IN 1" HEIGHT AND ANGLE.



Angled down:
Flows parts to front. Provides maximum accessibility.

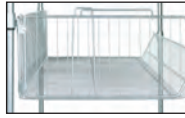

Flat:
Provides maximum space efficiency.



Angled up:
Provides maximum bin capacity.

STEM CASTER
W/BRAKE



STATIONARY RACK WITH OPTIONAL BIN DIVIDERS

Overall W"x D"x H"	Bin Size W"x D"x H"	STATIONARY RACK Model	MOBILE RACK Model	BIN DIVIDERS Model
36 x 18 x 63	36 x 14 x 9	SC832200	SC832206	SC832138B
36 x 24 x 63	36 x 20 x 9	SC832201	SC832207	SC832144B
48 x 18 x 63	48 x 14 x 9	SC832203	SC832209	SC832138B
48 x 24 x 63	48 x 20 x 9	SC832204	SC832210	SC832144B

5 GALLON WATER BOTTLE STORAGE RACK

Water Bottle Storage Racks organizes your bottles and stores them off the floor. Easy access and circulation of new and used bottles. Available in 4, 6, 8, 12 and 16 bottle rack capacities.

Features:

- Easily organize and store bulky 5 gallon water bottles
- Assembles and adjusts without tools
- 600 lbs Holding capacity for each shelf
- Poly-Z-Brite finish with 15 Year Limited Warranty against rust and corrosion
- Adjustable feet allows precise height adjustment of each post for complete rack stability



SC797087

W"x D"x H"	Bottle Cap.	Model
24 x 18 x 54	4	SC797083
36 x 18 x 54	6	SC797084
24 x 24 x 54	8	SC797085
36 x 24 x 54	12	SC797086
48 x 24 x 54	16	SC797087

WINE BOTTLE WIRE RACKS

Wine Bottle Racks are an attractive and safe way to display and store wine bottles. Each bottle is securely cradled by heavy gauge wire to prevent movement. Adjustable shelves allow storage of many different sizes of bottles. Our open wire construction permits air to circulate around the bottles for an even temperature. The 36" wide shelves accommodate 9 bottles and the 48" wide shelves accommodate 13 bottles. Posts include bottom Leveling Feet and top Post Caps. The electroplated nickel-chrome finish is durable, chip resistant and attractive for use in retail display.



SC797149

W" x H"	Bottle Cap.	Shelf Levels	Model
36 x 34	27	3	SC797142
36 x 34	36	4	SC797143
48 x 34	39	3	SC797144
48 x 34	52	4	SC797145
48 x 42	65	5	SC797146
48 x 54	78	6	SC797147
48 x 63	91	7	SC797148
48 x 74	104	8	SC797149

NEXELITE VENTED PLASTIC SHELVING

400 lb. capacity Shelf

This 4-shelf unit's high strength steel frame includes the **Nexgard antimicrobial finish** to fight mildew and bacteria growth. Shelves and frame include **Nexelon** finish for superior moisture and temperature resistance. Shelves adjust and align easily on numbered posts on 1" centers. Includes dishwasher safe, chip resistant polymer shelf mats with diagonal vents for ventilation. Includes 4 posts and 4 shelves with **400 lb. capacity** each. Easy, tool-free assembly. Add casters for mobility. Limited Lifetime Warranty against corrosion.



SHELVES REMOVE EASILY FOR CLEANING

NSF

WITH NEXGARD ANTI MICROBIAL FINISH

SC331526N

ACCESSORIES

ADDITIONAL SHELVES

W"x D"	Model	W"x D"	Model
30 x 18	SC331469N	30 x 24	SC331472N
36 x 18	SC331576N	36 x 24	SC331580N
42 x 18	SC331470N	42 x 24	SC331473N
48 x 18	SC331577N	48 x 24	SC331581N
54 x 18	SC331471N	54 x 24	SC331475N
60 x 18	SC331578N	60 x 24	SC331582N
72 x 18	SC331579N	72 x 24	SC331583N

SHELF LEDGES - Poly-Z-Brite finish

Model	L"x H"	Model	L"x H"
SC331433	18 x 4	SC331437	42 x 4
SC331434	24 x 4	SC331438	48 x 4
SC331435	30 x 4	SC331439	54 x 4
SC331436	36 x 4	SC331440	60 x 4
		SC331441	72 x 4

SHELF DIVIDERS -

Poly-Z-Brite finish.

Model L"x H"

SC331442 18 x 8

SC331443 24 x 8

LABEL HOLDER -

Snaps onto shelf,

slide in label.

Model L"

SC331444 3

W"x D"x H"	Model	W"x D"x H"	Model	W"x D"x H"	Model
30 x 18 x 54	SC331451N	30 x 18 x 63	SC331457N	30 x 18 x 74	SC331463N
36 x 18 x 54	SC331518N	36 x 18 x 63	SC331526N	36 x 18 x 74	SC331534N
42 x 18 x 54	SC331452N	42 x 18 x 63	SC331458N	42 x 18 x 74	SC331464N
48 x 18 x 54	SC331519N	48 x 18 x 63	SC331527N	48 x 18 x 74	SC331535N
54 x 18 x 54	SC331453N	54 x 18 x 63	SC331459N	54 x 18 x 74	SC331465N
60 x 18 x 54	SC331520N	60 x 18 x 63	SC331528N	60 x 18 x 74	SC331536N
72 x 18 x 54	SC331521N	72 x 18 x 63	SC331529N	72 x 18 x 74	SC331537N
30 x 24 x 54	SC331454N	30 x 24 x 63	SC331460N	30 x 24 x 74	SC331466N
36 x 24 x 54	SC331522N	36 x 24 x 63	SC331530N	36 x 24 x 74	SC331538N
42 x 24 x 54	SC331455N	42 x 24 x 63	SC331461N	42 x 24 x 74	SC331467N
48 x 24 x 54	SC331523N	48 x 24 x 63	SC331531N	48 x 24 x 74	SC331539N
54 x 24 x 54	SC331456N	54 x 24 x 63	SC331462N	54 x 24 x 74	SC331468N
60 x 24 x 54	SC331524N	60 x 24 x 63	SC331532N	60 x 24 x 74	SC331540N
72 x 24 x 54	SC331525N	72 x 24 x 63	SC331533N	72 x 24 x 74	SC331541N

OPTIONAL STEM CASTERS- fits both Solid and Vented

Plastic Shelving.- (Not for use with Best Value Shelving)

D" x W"	Description	Cap. Lbs.	Model
5 x 1 1/4	Polyurethane swivel	1200	SC184835C
5 x 1 1/4	Polyurethane swivel 2 w/brake	1200	SC184912C
5 x 1 1/4	Stainless Steel Polyurethane swivel 2 w/brake	1200	SC241346C
8 x 2.80	Full-pneumatic non-marring	1000	SC184938C

BOLTLESS SHELVING *Designed for Instant Assembly... Maximum Strength at a Low Cost!*



HEAVY-DUTY Single Rivet Beams -

When additional storage space is needed.



EXTRA HEAVY-DUTY Double Rivet Beams -

When additional weight capacity is needed.



Configured for Easy Ordering

Provides easy access to stored items from all sides. Super-strong roll formed steel framing with positive interlocking beam and post connection. 2 1/4" x 1 1/2" x 14 gauge uprights. All units include double rivet top and bottom beams for added rigidity. **Heavy-Duty Model** has single rivet cross and front to back beams on intermediate levels. **Extra Heavy-Duty Model** has double rivet beams on all levels. Available with rugged 5/8" particle wood or high quality wire decking with epoxy finish. Beams that adjust vertically on 1 1/2" increments support both shelf types. Choose the size and load capacities that match your needs. Easily reconfigure unit as your requirements change. Fast, easy assembly in less than half the time of conventional shelving. No tools, nuts, bolts, clips or cutting required. Durable gray baked enamel.

SHELF CAPACITIES

W" x D"	HEAVY-DUTY	EXTRA
	Lbs./ Shelf	HEAVY-DUTY Lbs./ Shelf
36 x 12	300	1500
36 x 18	300	1500
36 x 24	300	1500
48 x 12	225	1500
48 x 18	225	1500
48 x 24	225	1200

HEAVY-DUTY
SC255424

EXTRA HEAVY-DUTY
SC601894

5' & 6' HIGH BOLTLESS SHELVING

NO DECK

WOOD DECK

WIRE DECK

W" x D"	NO DECK		WOOD DECK		WIRE DECK	
	HEAVY-DUTY Model	EXTRA HEAVY-DUTY Model	HEAVY-DUTY Model	EXTRA HEAVY-DUTY Model	HEAVY-DUTY Model	EXTRA HEAVY-DUTY Model
	5' HIGH 4 SHELVES		5' HIGH 4 SHELVES		5' HIGH 4 SHELVES	
36 x 12	SC254421	SC601866	SC254433	SC601878	SC601920	SC601890
36 x 18	SC254422	SC601867	SC254434	SC601879	SC601921	SC601891
36 x 24	SC254423	SC601868	SC254435	SC601880	SC601922	SC601892
48 x 12	SC254424	SC601869	SC254436	SC601881	SC601923	SC601893
48 x 18	SC254425	SC601870	SC254437	SC601882	SC601924	SC601894
48 x 24	SC254426	SC601871	SC254438	SC601883	SC601925	SC601895
	5' HIGH 5 SHELVES		5' HIGH 5 SHELVES		5' HIGH 5 SHELVES	
36 x 12	SC255400	SC255412	SC255424	SC255436	SC255448	SC255460
36 x 18	SC255401	SC255413	SC255425	SC255437	SC255449	SC255461
36 x 24	SC255402	SC255414	SC255426	SC255438	SC255450	SC255462
48 x 12	SC255403	SC255415	SC255427	SC255439	SC255451	SC255463
48 x 18	SC255404	SC255416	SC255428	SC255440	SC255452	SC255464
48 x 24	SC255405	SC255417	SC255429	SC255441	SC255453	SC255465
	5' HIGH 6 SHELVES		5' HIGH 6 SHELVES		5' HIGH 6 SHELVES	
36 x 12	SC255406	SC255418	SC255430	SC255442	SC255454	SC255466
36 x 18	SC255407	SC255419	SC255431	SC255443	SC255455	SC255467
36 x 24	SC255408	SC255420	SC255432	SC255444	SC255456	SC255468
48 x 12	SC255409	SC255421	SC255433	SC255445	SC255457	SC255469
48 x 18	SC255410	SC255422	SC255434	SC255446	SC255458	SC255470
48 x 24	SC255411	SC255423	SC255435	SC255447	SC255459	SC255471
	6' HIGH 4 SHELVES		6' HIGH 4 SHELVES		6' HIGH 4 SHELVES	
36 x 12	SC255620	SC255638	SC255656	SC255674	SC255692	SC255710
36 x 18	SC255621	SC255639	SC255657	SC255675	SC255693	SC255711
36 x 24	SC255622	SC255640	SC255658	SC255676	SC255694	SC255712
48 x 12	SC255623	SC255641	SC255659	SC255677	SC255695	SC255713
48 x 18	SC255624	SC255642	SC255660	SC255678	SC255696	SC255714
48 x 24	SC255625	SC255643	SC255661	SC255679	SC255697	SC255715
	6' HIGH 5 SHELVES		6' HIGH 5 SHELVES		6' HIGH 5 SHELVES	
36 x 12	SC255626	SC255644	SC255662	SC255680	SC255698	SC255716
36 x 18	SC255627	SC255645	SC255663	SC255681	SC255699	SC255717
36 x 24	SC255628	SC255646	SC255664	SC255682	SC255700	SC255718
48 x 12	SC255629	SC255647	SC255665	SC255683	SC255701	SC255719
48 x 18	SC255630	SC255648	SC255666	SC255684	SC255702	SC255720
48 x 24	SC255631	SC255649	SC255667	SC255685	SC255703	SC255721
	6' HIGH 6 SHELVES		6' HIGH 6 SHELVES		6' HIGH 6 SHELVES	
36 x 12	SC255632	SC255650	SC255668	SC255686	SC255704	SC255722
36 x 18	SC255633	SC255651	SC255669	SC255687	SC255705	SC255723
36 x 24	SC255634	SC255652	SC255670	SC255688	SC255706	SC255724
48 x 12	SC255635	SC255653	SC255671	SC255689	SC255707	SC255725
48 x 18	SC255636	SC255654	SC255672	SC255690	SC255708	SC255726
48 x 24	SC255637	SC255655	SC255673	SC255691	SC255709	SC255727

COMPARE OUR STEEL SHELVES TO "BARGAIN DEPOT'S"!

Global's quality and price come out on top. In our latest product test, we compared our best-selling Global Boltless Steel Shelving to Home Depot's. Our product was the overwhelming winner on quality, capacity and weight. Our load capacity test proved that our **Extra Heavy-Duty** shelves held over **1,500 lbs.** while

theirs failed at only **760 lbs.** Our quality $\frac{5}{8}$ " thick particle board decking withstood twice the load versus their lighter weight $\frac{1}{2}$ " wood decking. For added strength, Global's sturdy, 14 gauge uprights are made of one continuous piece of roll-formed steel versus their two-piece clipped together construction. Our unit weighed 84.5 lbs., their unit weighed only 48.5 lbs.

THEIRS



THEIR 1/2" THICK DECK



PASSED

OURS

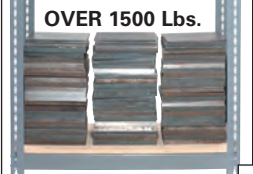

OVER 1500 Lbs.



OUR 5/8" THICK DECK

PASSED

THEIR 2 PIECE POST WEAKENS INTEGRITY AND STABILITY



THEIRS

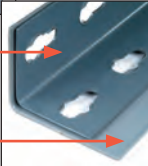

OURS BIGGER AND HEAVIER

STRONG STURDY 1 PIECE POST

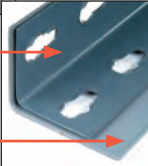

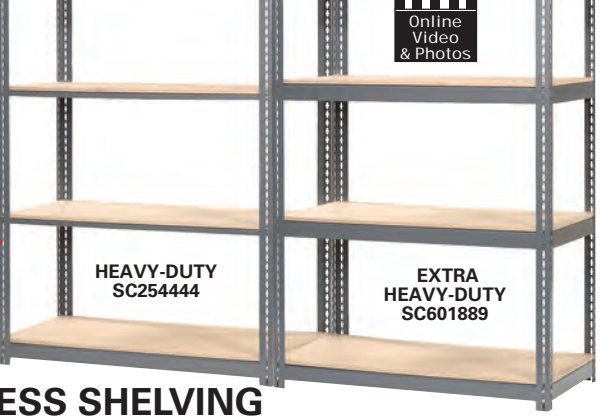

HEAVY-DUTY SC254444

EXTRA HEAVY-DUTY SC601889

Online Video & Photos

7' & 8' HIGH BOLTLESS SHELVING

W" x D"	NO DECK		WOOD DECK		WIRE DECK	
	HEAVY-DUTY Model	EXTRA HEAVY-DUTY Model	HEAVY-DUTY Model	EXTRA HEAVY-DUTY Model	HEAVY-DUTY Model	EXTRA HEAVY-DUTY Model
36 x 12 36 x 18 36 x 24 48 x 12 48 x 18 48 x 24	7' HIGH 5 SHELVES SC254427 SC254428 SC254429 SC254430 SC254431 SC254432	SC601872 SC601873 SC601874 SC601875 SC601876 SC601877	7' HIGH 5 SHELVES SC254439 SC254440 SC254441 SC254442 SC254443 SC254444	SC601884 SC601885 SC601886 SC601887 SC601888 SC601889	7' HIGH 5 SHELVES SC601926 SC601927 SC601928 SC601929 SC601930 SC601931	SC601896 SC601897 SC601898 SC601899 SC601900 SC601901
36 x 12 36 x 18 36 x 24 48 x 12 48 x 18 48 x 24	7' HIGH 6 SHELVES SC255472 SC255473 SC255474 SC255475 SC255476 SC255477	SC255484 SC255485 SC255486 SC255487 SC255488 SC255489	7' HIGH 6 SHELVES SC255496 SC255497 SC255498 SC255499 SC255500 SC255501	SC255508 SC255509 SC255510 SC255511 SC255512 SC255513	7' HIGH 6 SHELVES SC255520 SC255521 SC255522 SC255523 SC255524 SC255525	SC255532 SC255533 SC255534 SC255535 SC255536 SC255537
36 x 12 36 x 18 36 x 24 48 x 12 48 x 18 48 x 24	7' HIGH 7 SHELVES SC255478 SC255479 SC255480 SC255481 SC255482 SC255483	SC255490 SC255491 SC255492 SC255493 SC255494 SC255495	7' HIGH 7 SHELVES SC255502 SC255503 SC255504 SC255505 SC255506 SC255507	SC255514 SC255515 SC255516 SC255517 SC255518 SC255519	7' HIGH 7 SHELVES SC255526 SC255527 SC255528 SC255529 SC255530 SC255531	SC255538 SC255539 SC255540 SC255541 SC255542 SC255543
36 x 12 36 x 18 36 x 24 48 x 12 48 x 18 48 x 24	8' HIGH 5 SHELVES SC254427H SC254428H SC254429H SC254430H SC254431H SC254432H	SC601872H SC601873H SC601874H SC601875H SC601876H SC601877H	8' HIGH 5 SHELVES SC254439H SC254440H SC254441H SC254442H SC254443H SC254444H	SC601884H SC601885H SC601886H SC601887H SC601888H SC601889H	8' HIGH 5 SHELVES SC601926H SC601927H SC601928H SC601929H SC601930H SC601931H	SC601896H SC601897H SC601898H SC601899H SC601900H SC601901H
36 x 12 36 x 18 36 x 24 48 x 12 48 x 18 48 x 24	8' HIGH 6 SHELVES SC255544 SC255545 SC255546 SC255547 SC255548 SC255549	SC255556 SC255557 SC255558 SC255559 SC255560 SC255561	8' HIGH 6 SHELVES SC255568 SC255569 SC255570 SC255571 SC255572 SC255573	SC255580 SC255581 SC255582 SC255583 SC255584 SC255585	8' HIGH 6 SHELVES SC255592 SC255593 SC255594 SC255595 SC255596 SC255597	SC255604 SC255605 SC255606 SC255607 SC255608 SC255609
36 x 12 36 x 18 36 x 24 48 x 12 48 x 18 48 x 24	8' HIGH 7 SHELVES SC255550 SC255551 SC255552 SC255553 SC255554 SC255555	SC255562 SC255563 SC255564 SC255565 SC255566 SC255567	8' HIGH 7 SHELVES SC255574 SC255575 SC255576 SC255577 SC255578 SC255579	SC255586 SC255587 SC255588 SC255589 SC255590 SC255591	8' HIGH 7 SHELVES SC255598 SC255599 SC255600 SC255601 SC255602 SC255603	SC255610 SC255611 SC255612 SC255613 SC255614 SC255615

BUILD YOUR OWN BOLTLESS SHELVING *Choice of Gray or Tan*

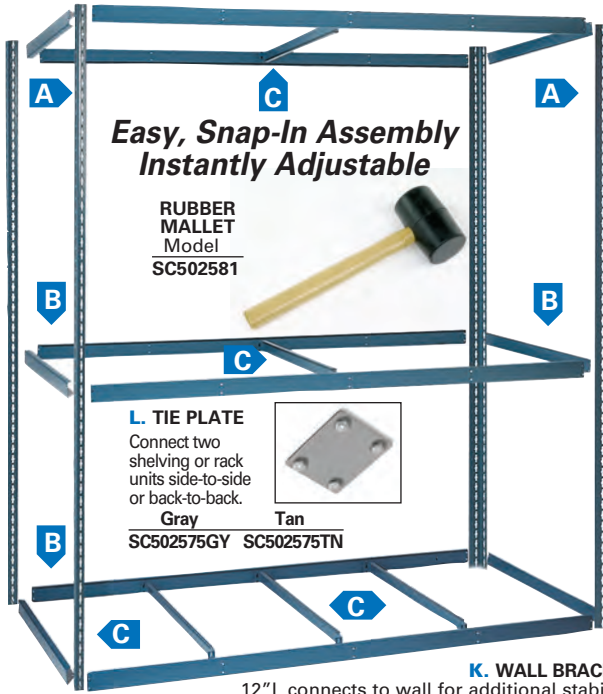

Easy, Snap-In Assembly Instantly Adjustable

RUBBER MALLET
Model
SC502581

L. TIE PLATE

Connect two shelving or rack units side-to-side or back-to-back.

Gray Tan
SC502575GY SC502575TN

K. WALL BRACKET

12"L connects to wall for additional stability.

CASTERS 2 rigid, 2 swivel - attach to Dolly Base to mobilize your storage rack. 1200 lb. Cap/set.

H. 8" x 2" Rubber Tire wheels. SC502591

I. 5" x 1 1/4" Non-Marring Polyurethane wheels. SC502590

J. 8" x 2.80" Non-Marring Pneumatic wheels. SC502592



G. DOLLY BASE. Rugged 14 gauge welded frame. 1200 lb. capacity. Gray enamel finish. Order casters separately.

Model	W" x D"
SC502587	36 x 18
SC502588	36 x 24
SC502589	48 x 24
SC502593	60 x 24

Gray Tan
SC502576GY SC502576TN

DECK

W" x D"

WOOD	MELAMINE
36 x 12 SC505222	36 x 12 SC31760
36 x 18 SC505223	36 x 18 SC31761
36 x 24 SC505224	36 x 24 SC31762
42 x 15 SC505227	---
42 x 30 SC505228	---
48 x 12 SC505225	48 x 12 SC331763
48 x 18 SC505266	48 x 18 SC331764
48 x 24 SC505233	48 x 24 SC331765
48 x 36 SC502534	48 x 36 SC331766
48 x 48 SC502535	48 x 48 SC331767
60 x 18 SC505229*	---
60 x 24 SC502536*	---
60 x 36 SC502537*	60 x 24 SC331768*
60 x 48 SC502538*	48 x 12 SC331769*
72 x 15 SC502539*	48 x 18 SC331770*
72 x 24 SC502540*	---
72 x 30 SC502541*	---
72 x 36 SC502542*	48 x 24 SC331771*
72 x 48 SC502543*	---
96 x 24 SC502544*	36 x 12 SC331772*
96 x 36 SC502545*	36 x 18 SC331773*
96 x 48 SC502546*	36 x 24 SC331774*
	48 x 12 SC331775*
	48 x 18 SC331776*
	48 x 24 SC331777*

*Ships in 2 pieces

A. UPRIGHTS. Punched on 1 1/2" centers for easy beam adjustment. 14 gauge.

ANGLE POST 2 1/4" x 1 1/2"

"T" POST 3 3/4" x 1 1/4"

Used to add on adjacent units.

Size'	Gray	Tan	Gray	Tan
3	SC502691	SC502696	---	---
5	SC502692	SC502697	SC502701	SC502704
6	SC502688	SC502689	---	---
7	SC502693	SC502698	SC502702	SC502705
8	SC502694	SC502699	SC502703	SC502706
10	SC502695	SC502700	---	---

B. BEAMS. Each level requires four. See previous page for capacities. Use **Double Rivet Beams** on top and bottom levels of all units. Use **Single Rivet Beams** on all intermediate levels, or increase capacity by using **Double Rivet Beams** on all levels. **Sample Unit: Heavy Duty, 5 Shelf 48" x 24"** Order: 6-48" & 6-24" Single Rivet Beams, 4-Uprights, 4-48" & 4-24" Double Rivet Beams: **Extra Heavy Duty, 5 Shelf, 48" x 24"** Order: 4-Uprights, 10-48" & 10-24" Double Rivet Beams. Beams can be used as ledges at any required height to prevent merchandise from falling or rolling off shelves.

SINGLE RIVET

DOUBLE RIVET

Size"	Gray	Tan	Gray	Tan
12	SC502579	SC331641	SC505231	SC331646
15	---	---	SC502264	SC331647
18	SC502580	---	SC505232	SC331648
24	SC505233	SC331643	SC502265	SC331649
30	---	---	SC502266	SC331650
36	SC502577	---	SC502267	SC331651
42	---	---	SC502269	SC331599
48	SC502578	---	SC502268	SC331652
60	---	---	SC502260	SC331653
72	---	---	SC502261	SC331654
96 angle	---	---	SC502262	SC331655
96 channel-30% greater capacity	---	---	SC502263	SC331656

C. DECK CENTER SUPPORTS

Increases shelf capacity by 20%. Fits double rivet beams only. 42", 48", 60", and 72"L beams accept 1 support per level; 96"L accepts up to 3.

Depth"

15	SC331657	SC331658
18	SC505220	SC331659
24	SC505259	SC331660
30	SC505221	SC331661
36	SC502570	SC331662
48	SC502571	SC331663

ADDITIONAL SHELF LEVELS

EXTRA HEAVY DUTY

NO DECK

Model	W" x D"
SC601902	36 x 12
SC601903	36 x 18
SC601904	36 x 24
SC601905	48 x 12
SC601906	48 x 18
SC601907	48 x 24

EXTRA HEAVY DUTY WOOD DECK

SC601908	36 x 12
SC601909	36 x 18
SC601910	36 x 24
SC601911	48 x 12
SC601912	48 x 18
SC601913	48 x 24

EXTRA HEAVY DUTY WIRE DECK

SC601914	36 x 12
SC601915	36 x 18
SC601916	36 x 24
SC601917	48 x 12
SC601918	48 x 18
SC601919	48 x 24

MAGNETIC LABEL *Write On*



A quick and economical method of labeling. Easy to use. Simply write on with wet erase pen. Cut to desired length. Magnet will adhere to all metal surfaces. To change, wipe off with damp cloth. Comes in 50' long rolls. White only.

Model	H"
SC764276	1
SC764277	2
SC764278	3

MAGNETIC CARD HOLDERS



Insertable black magnetic "C" channel design allow for labels to be changed simply by re-marking the paper insert or re-positioning the magnet. Great for metal racks, shelves, bins, and more. Replaceable paper inserts included. 25 per package.

Model	W" x H"
SC189046	3 x 1
SC189047	3 x 2
SC189048	6 x 1
SC189049	6 x 2
SC189050	6 x 3

BOLTLESS SHELVING WITH LAMINATED SHELVES

EXTRA-HEAVY DUTY SHELVING Includes Double Rivet cross-beams and front-to-back beams on all shelves to support laminated shelf decking. 1,500 lb. capacity per shelf. Units available in 5, 7, and 8 foot heights and choice of 4-7 shelves. Extra-Heavy duty shelving available in Gray or Tan. Add color suffix: Gray (GY) or Tan (TN).

W"x D"	Shelf Cap. Lbs.	Model	Model	Model
5' HIGH 4 SHELF				
36 x 12	1500	SC235412	SC235430	SC236767
36 x 18	1500	SC235413	SC235431	SC236768
36 x 24	1500	SC235414	SC235432	SC236769
7' HIGH 5 SHELF				
48 x 12	1500	SC235415	SC235433	SC236770
48 x 18	1500	SC235416	SC235434	SC236771
48 x 24	1200	SC235417	SC235435	SC236772
5' HIGH 5 SHELF				
36 x 12	1500	SC236743	SC236755	SC236773
36 x 18	1500	SC236744	SC236756	SC236774
36 x 24	1500	SC236745	SC236757	SC236775
7' HIGH 6 SHELF				
48 x 12	1500	SC236746	SC236758	SC236776
48 x 18	1500	SC236747	SC236759	SC236777
48 x 24	1200	SC236748	SC236760	SC236778
5' HIGH 6 SHELF				
36 x 12	1500	SC236749	SC236761	SC236779
36 x 18	1500	SC236750	SC236762	SC236780
36 x 24	1500	SC236751	SC236763	SC236781
7' HIGH 7 SHELF				
48 x 12	1500	SC236752	SC236764	SC236782
48 x 18	1500	SC236753	SC236765	SC236783
48 x 24	1200	SC236754	SC236766	SC236784

ADDITIONAL SHELVES

W"x D"	Cap. Lbs.	Model	W"x D"	Cap. Lbs.	Model
36 x 12	1500	SC235448	48 x 12	1500	SC235451
36 x 18	1500	SC235449	48 x 18	1500	SC235452
36 x 24	1500	SC235450	48 x 24	1200	SC235453



SC235431GY



SC235430GY

BOLTLESS LUGGAGE GARMENT RACK

DOUBLE UNIT



SINGLE COMBO UNIT



SINGLE UNIT



All models are 7' high, 1200 lb. per shelf capacity featuring Heavy Duty Wire Decking. Provides easy access to stored items from all sides. Super strong roll formed steel framing with positive interlocking beam and post connection. Choose the size that matches your needs. Durable gray backed enamel finish.

W" x D"	Type	Model
48 x 24	Single Unit	SC796545
96 x 24	Double Unit	SC796546
144 x 24	Triple Unit	SC796547
48 x 48	Single Combo Unit	SC796548
96 x 48	Double Combo Unit	SC796549
144 x 48	Triple Combo Unit	SC796550

SEE PAGE 30 FOR COMPONENTS

01-800-467-0529

chproductos.com

31

BOLTLESS WIDE SPAN STORAGE RACK

*With or Without
Wood Decking*

*Low Cost
Super Strong*

This economical wide span rack gives you extra space for bulky materials. Boltless assembly with snap together components requires no nuts, bolts, clips or tools. Uprights are a substantial 1 1/2" x 2 1/4" x 14 gauge steel. Unit includes 3 shelves, adjustable at 1 1/2" increments. Heavy-duty roll-formed steel framing with chip resistant gray baked enamel finish. All models have double riveted horizontal beams for maximum frame rigidity. Choose shelving without decking (supply your own) or sturdy 5/8" thick precut particleboard decking. For rack with wire or laminate decking, see page 69.

FOR ADDED STRENGTH:

60"W and 72"W models include 1 center deck support per shelf.

96"W models include 3 center deck supports per shelf.

96"W models with 1100 lb. capacity include extra heavy duty C-channel beams and 3 center deck supports per shelf.

**ONLY 2 BASIC
COMPONENTS:
UPRIGHTS
AND BEAMS**

**DOUBLE RIVET
EASY LOCK-IN
ASSEMBLY**



3 SHELVES PER UNIT

**ADDITIONAL CENTER
DECK SUPPORTS**

Increases shelf capacity by 20%. 48", 60" and 72"W beams accept 1 support per level; 96" L accept up to 3.

Shelf Depth"	Model
24	SC502569A
30	SC505221A
36	SC502570A
48	SC502571A

Shelf W" x D"	Cap. Lbs.	5' HIGH		7' HIGH		8' HIGH		ADDITIONAL LEVEL	
		WITHOUT DECKING Model	WITH DECKING Model	WITHOUT DECKING Model	WITH DECKING Model	WITHOUT DECKING Model	WITH DECKING Model	WITHOUT DECKING Model	WITH DECKING Model
48 x 24	1200	SC600216	SC601750	SC601700	SC601457A	SC601718	SC601467A	SC502400	SC601477A
48 x 36	1200	SC600217	SC601751	SC601701	SC601461A	SC601719	SC601468A	SC502401	SC601478A
48 x 48	1200	SC600218	SC601752	SC601702	SC601465A	SC601720	SC601471A	SC502402	SC601481A
60 x 24	1200	SC600220	SC601754	SC601704	SC601130A	SC601722	SC601134A	SC502404	SC601139A
60 x 36	1200	SC600222	SC601756	SC601706	SC601131A	SC601724	SC601135A	SC502406	SC601140A
60 x 48	1200	SC600224	SC601758	SC601708	SC601132A	SC601726	SC601136A	SC502408	SC601141A
72 x 24	900	SC601240	SC601243	SC601246	SC601249	SC601252	SC601255	SC601258	SC601261
72 x 30	900	SC601241	SC601244	SC601247	SC601250	SC601253	SC601256	SC601259	SC601262
72 x 36	900	SC601242	SC601245	SC601248	SC601251	SC601254	SC601257	SC601260	SC601263
72 x 48	900	SC600230	SC601764	SC601714	SC601133A	SC601732	SC601137A	SC502414	SC601138A
96 x 24	800	SC600231	SC601765	SC601631	SC601634A	SC601637	SC601640A	SC502437	SC601643A
96 x 24	1100	SC600232	SC601766	SC601715	SC601487A	SC601733	SC601490A	SC502415	SC601493A
96 x 36	800	SC600233	SC601767	SC601632	SC601635A	SC601638	SC601641A	SC502438	SC601644A
96 x 36	1100	SC600234	SC601768	SC601716	SC601488A	SC601734	SC601491A	SC502416	SC601494A
96 x 48	800	SC600235	SC601769	SC601633	SC601636A	SC601639	SC601642A	SC502439	SC601645A
96 x 48	1100	SC600236	SC601770	SC601717	SC601489A	SC601735	SC601492A	SC502417	SC601495A

BOLTLESS EXPANDABLE BULK STORAGE RACK

Quick & Cost effective way to Create Rows & Aisles

Extremely durable and dependable, these racks assemble and expand easily and allow access from all sides. Boltless design snaps together securely without tools or hardware. Add-On Units include 2 T-posts that join units with more stability and less construction than bolting together 2 starter units. Roll formed 14 gauge steel uprights ensure rigidity. Levels adjust at 1 1/2" increments without disassembly. Scratch resistant enamel finish. Specify color suffix: Gray (GY) or Tan (TN).

- 96"W models with 800 lb. capacity include three center deck supports per level.
- 96"W models with 1100 lb. capacity include extra heavy duty C-channel beams and three center deck supports per level.



TEE POST



ANGLE POST

KEYHOLE SHAPE MAKES ASSEMBLY QUICK AND EASY.



STARTER UNIT



ADD-ON UNIT

STARTER UNIT includes 4 upright angle posts and 3 sets of horizontal beams. Select your own decking.

ADD-ON UNIT includes 2 upright T-posts and 3 sets of horizontal beams. Select your own decking.

Choose the Decking that suits your needs:

No decking - Economical - supply your own

Wood decking - Low cost, precut 5/8" thick particleboard

Wire decking - Allows visibility and light, air and sprinkler penetration (reducing insurance premiums). Epoxy finish.



GRAY (GY)



TAN (TN)

SC785614TN

SC785578TN

ALL RACKS ARE 7' HIGH WITH THREE STORAGE LEVELS

W"x D"	Shelf Cap. Lbs.	RACK WITHOUT DECK			RACK WITH WOOD DECK			RACK WITH WIRE DECK		
		STARTER Model	ADD-ON Model	ADD'L LEVEL Model	STARTER Model	ADD-ON Model	ADD'L LEVEL Model	STARTER Model	ADD-ON Model	ADD'L LEVEL Model
36 x 12	1500	SC785501	SC785519	SC785537	SC785555	SC785573	SC785591	SC785609	SC785627	SC785645
36 x 18	1500	SC785502	SC785520	SC785538	SC785556	SC785574	SC785592	SC785610	SC785628	SC785646
36 x 24	1500	SC785503	SC785521	SC785539	SC785557	SC785575	SC785593	SC785611	SC785629	SC785647
48 x 12	1500	SC785504	SC785522	SC785540	SC785558	SC785576	SC785594	SC785612	SC785630	SC785648
48 x 18	1500	SC785505	SC785523	SC785541	SC785559	SC785577	SC785595	SC785613	SC785631	SC785649
48 x 24	1500	SC785506	SC785524	SC785542	SC785560	SC785578	SC785596	SC785614	SC785632	SC785650
60 x 24	1000	SC785507	SC785525	SC785543	SC785561	SC785579	SC785597	SC785615	SC785633	SC785651
60 x 36	1000	SC785508	SC785526	SC785544	SC785562	SC785580	SC785598	SC785616	SC785634	SC785652
60 x 48	1000	SC785509	SC785527	SC785545	SC785563	SC785581	SC785599	SC785617	SC785635	SC785653
72 x 24	750	SC785510	SC785528	SC785546	SC785564	SC785582	SC785600	SC785618	SC785636	SC785654
72 x 36	750	SC785511	SC785529	SC785547	SC785565	SC785583	SC785601	SC785619	SC785637	SC785655
72 x 48	750	SC785512	SC785530	SC785548	SC785566	SC785584	SC785602	SC785620	SC785638	SC785656
96 x 24	800	SC785513	SC785531	SC785549	SC785567	SC785585	SC785603	SC785621	SC785639	SC785657
96 x 24	1100	SC785514	SC785532	SC785550	SC785568	SC785586	SC785604	SC785622	SC785640	SC785658
96 x 36	800	SC785515	SC785533	SC785551	SC785569	SC785587	SC785605	SC785623	SC785641	SC785659
96 x 36	1100	SC785516	SC785534	SC785552	SC785570	SC785588	SC785606	SC785624	SC785642	SC785660
96 x 48	800	SC785517	SC785535	SC785553	SC785571	SC785589	SC785607	SC785625	SC785643	SC785661
96 x 48	1100	SC785518	SC785536	SC785554	SC785572	SC785590	SC785608	SC785626	SC785644	SC785662

SEE PAGE 30 FOR COMPONENTS

01-800-467-0529

chproductos.com

33

BOLTLESS WIDE SPAN STORAGE RACK WITH WIRE OR LAMINATE DECKING

Up to 1200 lb. shelf capacity

LAMINATE DECKING



(GRAY OR TAN)

WIRE DECKING



(GRAY ONLY)

No nuts, bolts, clips or tools for assembly. Includes 3 shelves, adjustable at 1 1/2" increments. Heavy-duty roll-formed steel framing with chip resistant baked enamel finish. Uprights are 1 1/2" x 2 1/4" x 14 gauge steel. All models have double riveted horizontal beams for maximum frame rigidity. Choose shelving with epoxy finish **wire decking** that allows ventilation, visibility, and light and sprinkler penetration (reducing insurance premiums). Or

choose 1/2" thick particleboard decking covered in rugged **white laminate**. Specify rack color suffix for laminate only: **Gray (GY) or Tan (TN)**. For rack without decking or with particle board decking, see page 66. For added strength: **60"W and 72"W models include 1 center deck support per shelf. 96"W models with 800 lb. capacity include 3 center deck supports per shelf. 96"W include extra heavy duty C-channel beams and 3 center deck supports per shelf.**

LAMINATED DECK

W"x D"	Shelf Cap. Lbs.	5' HIGH Model	7' HIGH Model	8' HIGH Model
48 x 24	1200	SC504200	SC504212	SC504634
48 x 36	1200	SC504201	SC504213	SC504635
48 x 48	1200	SC504202	SC504214	SC504636
60 x 24	1200	SC504203	SC504215	SC504638
60 x 36	1200	SC504204	SC504216	SC504640
60 x 48	1200	SC504205	SC504217	SC504642
72 x 24	900	SC504206	SC504218	SC504645
72 x 36	900	SC504207	SC504219	SC504649
72 x 48	900	SC504208	SC504220	SC504651
96 x 24	800	SC504617	SC504629	SC504653
96 x 24	1100	SC504209	SC504221	SC504654
96 x 36	800	SC504619	SC504631	SC504656
96 x 36	1100	SC504210	SC504222	SC504657
96 x 48	800	SC504621	SC504633	SC504659
96 x 48	1100	SC504211	SC504223	SC504660

ADDITIONAL LEVEL WITH LAMINATED DECKING

W"x D"	Shelf Cap. Lbs.	Model	W"x D"	Shelf Cap. Lbs.	Model
48 x 24	1200	SC504256	96 x 24	800	SC504668
48 x 36	1200	SC504257	96 x 24	1100	SC504265
48 x 48	1200	SC504258	96 x 36	800	SC504670
60 x 24	1200	SC504259	96 x 36	1100	SC504266
60 x 36	1200	SC504260	96 x 48	800	SC504672
60 x 48	1200	SC504261	96 x 48	800	SC504267
72 x 24	900	SC504262			
72 x 36	900	SC504263			
72 x 48	900	SC504264			

WIRE DECK

W"x D"	Shelf Cap. Lbs.	5' HIGH Model	7' HIGH Model	8' HIGH Model
48 x 24	1200	SC502450	SC502462	SC502474
48 x 36	1200	SC502451	SC502463	SC502475
48 x 48	1200	SC502452	SC502464	SC502476
60 x 24	1200	SC502453	SC502465	SC502477
60 x 36	1200	SC502454	SC502466	SC502478
60 x 48	1200	SC502455	SC502467	SC502479
72 x 24	900	SC502456	SC502468	SC502480
72 x 36	900	SC502457	SC502469	SC502481
72 x 48	900	SC502458	SC502470	SC502482
96 x 24	800	SC502808	SC502820	SC502832
96 x 24	1100	SC502459	SC502471	SC502483
96 x 36	800	SC502810	SC502822	SC502834
96 x 36	1100	SC502460	SC502472	SC502484
96 x 48	800	SC502812	SC502824	SC502836
96 x 48	1100	SC502461	SC502473	SC502485

ADDITIONAL LEVEL WITH WIRE DECKING

W"x D"	Shelf Cap. Lbs.	Model	W"x D"	Shelf Cap. Lbs.	Model
48 x 24	1200	SC502486	96 x 24	800	SC502844
48 x 36	1200	SC502487	96 x 24	1100	SC502495
48 x 48	1200	SC502488	96 x 36	800	SC502846
60 x 24	1200	SC502489	96 x 36	1100	SC502496
60 x 36	1200	SC502490	96 x 48	800	SC502848
60 x 48	1200	SC502491	96 x 48	1100	SC502497
72 x 24	900	SC502492			
72 x 36	900	SC502493			
72 x 48	900	SC502494			

HEAVY LOAD RECORD STORAGE CENTER

Boxless 12-gauge steel horizontal beams have 3-hook connectors to install easily without tools and adjust in seconds at 2" increments. **Uprights are 14-gauge steel.** Rack finished in gray powder coating. Rugged 200 test corrugated transfer file boxes protect and organize records with double-thick front and back walls, large label area and hand holes for easy lifting. Boxes fit securely on rugged 5/8" thick particleboard decks. **Starter Unit** includes 2 upright frames, 3 or 4 shelf levels. **Add-On Unit** includes 1 upright frame, 3 or 4 shelf levels. 18"D units store one row of boxes; 36"D store two rows with access from both sides and includes 5 additional supports per level. Easy assembly.

W" x D" x H"	Cap. Lbs./Level	Levels	Boxes	STARTER Model	ADD-ON Model
60 x 18 x 72	3800	3	28	SC613129	SC613179
60 x 36 x 72	3800	3	56	SC613130	SC613180
72 x 18 x 72	2750	3	35	SC613131	SC613181
72 x 36 x 72	2750	3	70	SC613132	SC613182
96 x 18 x 72	2150	3	49	SC613133	SC613183
96 x 36 x 72	2150	3	98	SC613134	SC613184
60 x 36 x 96	3800	4	72	SC613135	SC613185
72 x 36 x 96	2750	4	90	SC613136	SC613186
96 x 36 x 96	2150	4	112	SC613137	SC613187

Transfer File/Record Storage with lid for letter and legal size records. Rugged 200 lbs. test corrugated. Ships flat. Easy to set up. Sold in package quantities of 20.

Model	Record Type	L" x W" x H"
SC336246B	Letter/Legal	15 x 12 x 10



EXTRA HEAVY LOAD RECORD STORAGE

Offers quick and easy, tool free assembly for all your document storage needs. Heavy duty one-piece, box formed 13 gauge steel uprights allow easy beam installation. 3/4" x 4 1/4" x 12 gauge welded base plates allow floor anchoring. Beams feature a positive 6-way locking action that automatically secures beam into place. Welded braces provide maximum rigidity and stability. Long lasting epoxy finish. Dust free wire mesh decking allows light and sprinkler penetration. Stores document boxes on front and back for two rows of storage and allows access from either side. Rack is available with 200 lb. test **Corrugated** or transparent high density **Polyethylene** boxes. Easy assembly.

W" x D" x H"	Shelf Cap lbs.	Levels	Boxes	STARTER Model	ADD-ON Model
15"L x 12"W x 10"H CORRUGATED BOXES INCLUDED					
48 x 36 x 96	6590	4	48	SC258192	SC258207
96 x 36 x 96	3230	4	112	SC258193	SC258208
120 x 36 x 96	5630	4	144	SC258194	SC258209
48 x 42 x 120	6590	5	60	SC258195	SC258210
96 x 42 x 120	3230	5	140	SC258196	SC258211
120 x 42 x 120	5630	5	180	SC258197	SC258212
24"L x 12"W x 10"H CORRUGATED BOXES INCLUDED					
48 x 48 x 96	6590	4	48	SC258198	SC258213
96 x 48 x 96	3230	4	112	SC258199	SC258214
120 x 48 x 96	5630	4	144	SC258200	SC258215
48 x 48 x 120	6590	5	60	SC258201	SC258216
96 x 48 x 120	3230	5	140	SC258202	SC258217
120 x 48 x 120	5630	5	180	SC258203	SC258218
21 1/2"L x 15"W x 12 1/2"H POLYETHYLENE BOXES INCLUDED					
48 x 48 x 96	6590	4	48	SC258204	SC258219
96 x 48 x 96	3230	4	96	SC258205	SC258220
120 x 48 x 96	5630	4	120	SC258206	SC258221

TRANSFER FILE/RECORD STORAGE with lid for letter and legal size records. Rugged 200 lbs. test corrugated. Ships flat. Easy to set up.

Model	Record Type	L" x W" x H"
SC336246C	Letter/Legal	15 x 12 x 10

Low Cost High Density Storage



POLYETHYLENE FILE BOX with hinged lid. Includes metal hanging file folder rails. 65 lb. capacity alone. 260 lb. capacity stacked. Sold in package quantity of 6.

Model	L" x W" x H"
SC506151B	21 1/2 x 15 x 12 1/2

SC258196

RECORD STORAGE CENTER

Rugged 200 test corrugated **TRANSFER FILE** with double-thick front/back walls keeps records protected and neatly organized... keeps out dust and dirt. Large printed label area for quick identification of contents and hand holes for easy handling. Boxes store securely on rugged $\frac{5}{8}$ " thick particleboard decks. Heavy gauge steel rack assemblies without tools. Choose durable gray or tan baked enamel finish. 15"D units store one row of boxes, 30"D allow double row storage or access from 2 sides.



SC516135



SC607180



SC336246

CART-N-CLIMB® Two 10" hard rubber rear wheels, two 4" lockstep hard rubber casters. 24"W x 35"L platform. 600 lb. capacity. (Not shown).

Model	Steps	Base W" x L"	Ht." Top Step	Overall
SC607180	3	24 x 52	30	60
SC607181	7	24 x 76	100	100

Gray	Tan	W" x D" x H"	Shelf Cap. lbs.	Levels	Boxes
RECORD STORAGE RACK With Transfer File					
SC130152	SC130156	42 x 15 x 36	1200	2	12
SC130153	SC130157	42 x 30 x 36	1200	2	24
SC130154	SC130158	72 x 15 x 36	900	2	20
SC130155	SC130159	72 x 30 x 36	900	2	40
SC130098	SC130113	42 x 15 x 60	1200	3	18
SC130099	SC130114	42 x 30 x 60	1200	3	36
SC130100	SC516134	72 x 15 x 60	900	3	30
SC130101	SC516135	72 x 30 x 60	900	3	60
SC130111	SC130115	42 x 15 x 84	1200	4	24
SC130112	SC130116	42 x 30 x 84	1200	4	48
SC130102	SC516136	72 x 15 x 84	900	4	40
SC130103	SC516137	72 x 30 x 84	900	4	80
RECORD STORAGE RACK Without Transfer File					
SC130160	SC130164	42 x 15 x 36	1200	2	---
SC130161	SC130165	42 x 30 x 36	1200	2	---
SC130162	SC130166	72 x 15 x 36	900	2	---
SC130163	SC130167	72 x 30 x 36	900	2	---
SC130145	SC130117	42 x 15 x 60	1200	3	---
SC130146	SC130118	42 x 30 x 60	1200	3	---
SC130147	SC130119	72 x 15 x 60	900	3	---
SC130148	SC130120	72 x 30 x 60	900	3	---
SC130149	SC130121	42 x 15 x 84	1200	4	---
SC130150	SC130122	42 x 30 x 84	1200	4	---
SC130151	SC130123	72 x 15 x 84	900	4	---
SC130125	SC130124	72 x 30 x 84	900	4	---

TRANSFER FILE/RECORD STORAGE with lid for letter and legal size records. Rugged 200 lbs. test corrugated. Model SC269838 flip top one piece design in color kraft. Sold in package quantities of 20. Ships flat easy to set up.

Model	Record Type	Size L" x W" x H"
SC336246	Letter/Legal	15 x 12 x 10

SECURE RECORD STORAGE Helps Prevent Theft, Moisture, Dust and Dirt!



SC607197TN

SC506151A

Tough translucent high density polyethylene hanging file boxes keep files organized. Metal rails organize letter hanging folders. Keep confidential documents secured with padlockable interlocking attached lid for stacking strength and eyelets molded-in the easy carry hand grips. Full length stainless steel hinge pins ensure security. 21 $\frac{1}{2}$ "L x 15"W x 12 $\frac{1}{2}$ "H. 65 lb. capacity. 260 lb. capacity when stacked up to 4 high. Securely store boxes on rugged $\frac{5}{8}$ " particle board decks with deck supports. Heavy duty steel rack uprights and double rivet beams for positive connection and assembly without tools. Baked enamel finish offered in gray or tan.

Gray	Tan	W" x D" x H"	Shelf Cap. lbs.	Levels	Boxes
SC607192GY	SC607192TN	48 x 24 x 60	1200	3	18
SC607193GY	SC607193TN	48 x 48 x 60	1200	3	36
SC607194GY	SC607194TN	72 x 24 x 60	900	3	24
SC607195GY	SC607195TN	72 x 48 x 60	900	3	48
SC607196GY	SC607196TN	96 x 24 x 60	800	3	36
SC607197GY	SC607197TN	96 x 48 x 60	800	3	72
SC607198GY	SC607198TN	48 x 24 x 84	1200	4	21
SC607199GY	SC607199TN	48 x 48 x 84	1200	4	42
SC607200GY	SC607200TN	72 x 24 x 84	900	4	28
SC607201GY	SC607201TN	72 x 48 x 84	900	4	56
SC607202GY	SC607202TN	96 x 24 x 84	800	4	42
SC607203GY	SC607203TN	96 x 48 x 84	800	4	84

POLYETHYLENE FILE BOX. Includes metal rail for hanging file folders. 65 lb. capacity alone. 260 lb. capacity stacked. Sold in package quantity of 6.

Model	L" x W" x H"
SC506151A	21 $\frac{1}{2}$ x 15 x 12 $\frac{1}{2}$

HIGH CAPACITY Z-BEAM BOLTLESS RACK

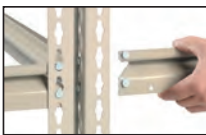

**TEE POST
KEYHOLE SHAPE
MAKES ASSEMBLY
EASY.**

**ROLL FORMED
STEEL BEAMS
FOR STRENGTH**

SHELF CAPACITIES

W"	Capacity Lbs.
48	1500
60	1300
72	1000
96	800

W" x D"	STARTER Model	ADD-ON Model	STARTER Model	ADD-ON Model
7' HIGH RACK WITH WOOD DECK⁸ HIGH RACK WITH WOOD DECK				
48 x 24	SC580890	SC580926	SC580934	SC581034
48 x 36	SC580891	SC580899	SC580927	SC581035
48 x 48	SC580892	SC581000	SC580928	SC581036
60 x 24	SC580893	SC581001	SC580929	SC581037
60 x 36	SC580894	SC581002	SC580930	SC581038
60 x 48	SC580895	SC581003	SC580931	SC581039
72 x 24	SC580896	SC581004	SC580932	SC581040
72 x 36	SC580897	SC581005	SC580933	SC581041
72 x 48	SC580898	SC581006	SC580934	SC581042
96 x 24	SC580899	SC581007	SC580935	SC581043
96 x 36	SC580900	SC581008	SC580936	SC581044
96 x 48	SC580901	SC581009	SC580937	SC581045

W" x D"	STARTER Model	ADD-ON Model	STARTER Model	ADD-ON Model
7' HIGH RACK WITH WIRE DECK⁸ HIGH RACK WITH WIRE DECK				
48 x 24	SC580914	SC581022	SC580950	SC581058
48 x 36	SC580915	SC581023	SC580951	SC581059
48 x 48	SC580916	SC581024	SC580952	SC581060
60 x 24	SC580917	SC581025	SC580953	SC581061
60 x 36	SC580918	SC581026	SC580954	SC581062
60 x 48	SC580919	SC581027	SC580955	SC581063
72 x 24	SC580920	SC581028	SC580956	SC581064
72 x 36	SC580921	SC581029	SC580957	SC581065
72 x 48	SC580922	SC581030	SC580958	SC581066
96 x 24	SC580923	SC581031	SC580959	SC581067
96 x 36	SC580924	SC581032	SC580960	SC581068
96 x 48	SC580925	SC581033	SC580961	SC581069

W" x D"	STARTER Model	ADD-ON Model	STARTER Model	ADD-ON Model
7' HIGH RACK WITH STEEL DECK⁸ HIGH RACK WITH STEEL DECK				
48 x 24	SC580902	SC581010	SC580938	SC581046
48 x 36	SC580903	SC581011	SC580939	SC581047
48 x 48	SC580904	SC581012	SC580940	SC581048
60 x 24	SC580905	SC581013	SC580941	SC581049
60 x 36	SC580906	SC581014	SC580942	SC581050
60 x 48	SC580907	SC581015	SC580943	SC581051
72 x 24	SC580908	SC581016	SC580944	SC581052
72 x 36	SC580909	SC581017	SC580945	SC581053
72 x 48	SC580910	SC581018	SC580946	SC581054
96 x 24	SC580911	SC581019	SC580947	SC581055
96 x 36	SC580912	SC581020	SC580948	SC581056
96 x 48	SC580913	SC581021	SC580949	SC581057

W" x D"	ADDITIONAL LEVELS		
	WOOD DECK Model	WIRE DECK Model	STEEL DECK Model
48 x 24	SC581070	SC581094	SC581082
48 x 36	SC581071	SC581095	SC581083
48 x 48	SC581072	SC581096	SC581084
60 x 24	SC581073	SC581097	SC581085
60 x 36	SC581074	SC581098	SC581086
60 x 48	SC581075	SC581099	SC581087
72 x 24	SC581076	SC581100	SC581088
72 x 36	SC581077	SC581101	SC581089
72 x 48	SC581078	SC581102	SC581090
96 x 24	SC581079	SC581103	SC581091
96 x 36	SC581080	SC581104	SC581092
96 x 48	SC581081	SC581105	SC581093



Horizontal beams are roll-formed to a Z-profile for added shelf capacity. Decking sits flush to beams for neater appearance and stability. 2 1/4" x 1 1/2" x 14-gauge uprights. Boltless, interlocking beams assemble quickly, without tools. 3 Levels adjust at 1 1/2" increments. Choose precut wood, long lasting steel or wire decking (which allows air and sprinkler penetration, reducing insurance premiums). Tan baked enamel finish. Starter Unit: 4 angle posts, 12 beams and decking. Add-On Unit: 2 T-posts, 12 beams and decking.

TIRE RACK

HEAVY DUTY TIRE RACK Perfect for automobile through tractor trailer tires, the additional capacity of these racks comes from the formed horizontal Z-beams. **Up to 3800 lb. capacity per level.** Sturdy units attach to walls using 4 included brackets. Boltless design allows horizontal beams to install easily without tools and to adjust in seconds at 2" increments. Heavy-duty 12-gauge beams have 3 hooks at each end for positive connection. Uprights are 14-gauge steel measuring 1 3/4" x 1 3/4". 24" depth models include 5 deck supports per level. Gray powder coat finish. Easy assembly. Built for tires only. **Add-On Units** extend Starter Units to build runs of any length.



W" x D" x H"	Levels	Tire Capacity	STARTER	ADD-ON
60 x 18 x 72	3	21	SC613138	SC613141
72 x 18 x 72	3	27	SC613139	SC613142
96 x 18 x 72	3	36	SC613140	SC613143
60 x 24 x 120	3	21	SC795815	SC795818
72 x 24 x 120	3	27	SC795816	SC795819
96 x 24 x 120	3	36	SC795817	SC795820

8" x 2" MOLD-ON RUBBER CASTER KIT
2 SWIVEL, 2 RIGID - 2,400 lb. Cap. For starter units only. Model **SC502591**

BOLTLESS TIRE RACK Safely store and display automobile and light truck tires with this strong roll formed steel rack with positive interlocking beam and post connection. Construction includes 2 1/4" x 1 1/2" x 14 gauge uprights and double riveted horizontal beams that adjust vertically on 1 1/2" increments. Fast, easy assembly without tools, nuts or bolts. Durable gray baked enamel. **1500 lb. capacity per level.** 84"H units attach to walls using 4 included brackets. 120"H includes 6 brackets. Built for tires only. **Single Sided** racks attach to wall for access from one side. **Double Sided** racks are 2 units joined with tie beams in between and provide access from either side.

**DOUBLE SIDED
ALLOWS
ACCESS
FROM 2 SIDES**

**SINGLE SIDED
SECURES TO WALL**



Description	Tire W" x D" x H"	Capacity	Model
3 Tier Single Sided	60 x 18 x 84	18	SC613144
3 Tier Double Sided	60 x 54 x 84	36	SC613145
4 Tier Single Sided	60 x 18 x 120	24	SC613146
4 Tier Double Sided	60 x 54 x 120	48	SC613147

EXTRA HIGH CAPACITY BULK RACK

Best Value on the Market - Up to 3800 lbs. Per Shelf

Easy to Assemble!

Choose the Decking that suits your needs: No Deck, Wood, Wire or Steel

- Wood Deck** - Low cost, precut 5/8" thick particleboard
- Wire Deck** - Allows visibility and light, air and sprinkler penetration (reducing insurance premiums) Epoxy finish.
- Steel Deck** - Long lasting, smooth surface.

WOOD DECK

This cost-effective, sturdy metal storage rack offers almost twice the capacity per level as standard racks thanks to the formed step Z-beam. Boltless design allows horizontal beams to install easily without tools and to adjust in seconds at 2" increments. Heavy-duty 12-gauge beams have 3 hooks at each end for positive connection. Uprights are 14-gauge steel measuring 1 3/4" x 1 3/4". Gray powder coat finish. **Easy assembly.**

Starter Unit

Includes 2 upright frames, 3 shelf levels and 15 deck supports.

Add-On Unit

Includes 1 upright frame, 3 shelf levels and 15 deck supports.

Models 18" depth units do not include deck supports.

DECK SUPPORTS



THREE HOOKS FOR POSITIVE CONNECTION



14 GAUGE DECK SUPPORTS LOADS



SAFETY PIN LOCKS BEAMS IN PLACE

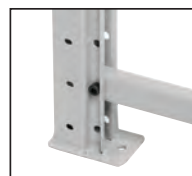

FOOT PLATES ALLOW RACK TO BE BOLTED TO THE FLOOR

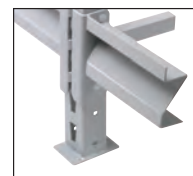

FORMED STEP BEAM CREATES EXTRA SUPPORT FOR INCREASED CAPACITY

NO DECK

WOOD DECK

WIRE DECK

STEEL DECK

W" x D" x H"	Cap Lbs./ Level	NO DECK		WOOD DECK		WIRE DECK		STEEL DECK	
		STARTER Model	ADD-ON Model	STARTER Model	ADD-ON Model	STARTER Model	ADD-ON Model	STARTER Model	ADD-ON Model
60 x 18 x 72	3800	SC504530	SC504533	SC504590	SC504591	-	-	-	-
60 x 24 x 72	3800	SC504407	SC504434	SC504281	SC504308	SC504464	SC504491	SC504344	SC504371
60 x 36 x 72	3800	SC504408	SC504435	SC504282	SC504309	SC504465	SC504492	SC504345	SC504372
60 x 48 x 72	3800	SC504409	SC504436	SC504283	SC504310	SC504466	SC504493	SC504346	SC504373
72 x 18 x 72	2750	SC504531	SC504534	SC504536	SC504538	SC504542	SC504544	-	-
72 x 24 x 72	2750	SC504410	SC504437	SC504284	SC504311	SC504467	SC504494	SC504347	SC504374
72 x 36 x 72	2750	SC504411	SC504438	SC504285	SC504312	SC504468	SC504495	SC504348	SC504375
72 x 48 x 72	2750	SC504412	SC504439	SC504286	SC504313	SC504469	SC504496	SC504349	SC504376
96 x 18 x 72	2150	SC504532	SC504535	SC504537	SC504539	SC504543	SC504545	-	-
96 x 24 x 72	2150	SC504413	SC504440	SC504287	SC504314	SC504470	SC504497	SC504350	SC504377
96 x 36 x 72	2150	SC504414	SC504441	SC504288	SC504315	SC504471	SC504498	SC504351	SC504378
96 x 48 x 72	2150	SC504415	SC504442	SC504289	SC504316	SC504472	SC504499	SC504352	SC504379
60 x 24 x 96	3800	SC504416	SC504443	SC504290	SC504317	SC504473	SC504500	SC504353	SC504380
60 x 36 x 96	3800	SC504417	SC504444	SC504291	SC504318	SC504474	SC504501	SC504354	SC504381
60 x 48 x 96	3800	SC504418	SC504445	SC504292	SC504319	SC504475	SC504502	SC504355	SC504382
72 x 24 x 96	2750	SC504419	SC504446	SC504293	SC504320	SC504476	SC504503	SC504356	SC504383
72 x 36 x 96	2750	SC504420	SC504447	SC504294	SC504321	SC504477	SC504504	SC504357	SC504384
72 x 48 x 96	2750	SC504421	SC504448	SC504295	SC504322	SC504478	SC504505	SC504358	SC504385
96 x 24 x 96	2150	SC504422	SC504449	SC504296	SC504323	SC504479	SC504506	SC504359	SC504386
96 x 36 x 96	2150	SC504423	SC504450	SC504297	SC504324	SC504480	SC504507	SC504360	SC504387
96 x 48 x 96	2150	SC504424	SC504451	SC504298	SC504325	SC504481	SC504508	SC504361	SC504388
60 x 24 x 120	3800	SC504425	SC504452	SC504299	SC504326	SC504482	SC504509	SC504362	SC504389
60 x 36 x 120	3800	SC504426	SC504453	SC504300	SC504327	SC504483	SC504510	SC504363	SC504390
60 x 48 x 120	3800	SC504427	SC504454	SC504301	SC504328	SC504484	SC504511	SC504364	SC504391
72 x 24 x 120	2750	SC504428	SC504455	SC504302	SC504329	SC504485	SC504512	SC504365	SC504392
72 x 36 x 120	2750	SC504429	SC504456	SC504303	SC504330	SC504486	SC504513	SC504366	SC504393
72 x 48 x 120	2750	SC504430	SC504457	SC504304	SC504331	SC504487	SC504514	SC504367	SC504394
96 x 24 x 120	2150	SC504431	SC504458	SC504305	SC504332	SC504488	SC504515	SC504368	SC504395
96 x 36 x 120	2150	SC504432	SC504459	SC504306	SC504333	SC504489	SC504516	SC504369	SC504396
96 x 48 x 120	2150	SC504433	SC504460	SC504307	SC504334	SC504490	SC504517	SC504370	SC504397

EXTRA HIGH CAPACITY BULK RACK

COMPARE OUR BULK RACK TO OTHERS

We've compared our 72"W x 36"D x 72"H bulk rack to the competitor's and after thorough testing, Global's quality comes out on top once again!

Our bulk rack weighed 31 lbs. heavier than the competition, giving it a more durable and stable construction. For added stability, our models include a welded base plate that allows floor anchoring. Our bulk racks include 4 built-in cross braces, giving our units added rigidity under high amounts of weight and pressure.

Our load capacity per shelf for this unit stands strong at **2750 lbs.**, while theirs stands at only **2000 lbs.** Shelf adjustments can be made easily on our unit at 2" increments while theirs offers 3".

Our .0615" deck supports offer greater capacity while theirs is half the gauge at .0335". Our bulk racks include safety pins for secure cross beam installation, and don't forget that our Z-beam designed cross beams allow greater capacity, strength and rigidity.



**Best Value On The Market
Up to 3800 lbs. Per Shelf**

BUILD YOUR OWN

WOOD DECK- 5/8" Tk. Particle. W" x D"		WIRE DECK-Epoxy Finish. W" x D"		UPRIGHTS- 13/4" x 13/4" 14 gauge. Gray powder coat finish.	
Model	Model	H" x D"	Model	H" x D"	Model
60 x 18	SC504592	72 x 18	SC504579	72 x 18	SC504550
60 x 24	SC504568	72 x 24	SC504580	72 x 24	SC504551
60 x 36	SC504569	72 x 36	SC504581	72 x 36	SC504552
60 x 48	SC504570	72 x 48	SC504582	72 x 48	SC504553
72 x 18	SC504571	96 x 24	SC504583	96 x 24	SC504554
72 x 24	SC504572	96 x 36	SC504584	96 x 36	SC504555
72 x 36	SC504573	96 x 48	SC504585	96 x 48	SC504556
72 x 48	SC504574	120 x 24	SC504586	120 x 24	SC504557
96 x 18	SC504575	120 x 36	SC504587	120 x 36	SC504558
96 x 24	SC504576	120 x 48	SC504588	120 x 48	SC504559
96 x 36	SC504577				
96 x 48	SC504578				

*Decks ship in 2 pieces

ADDITIONAL LEVELS

Include one pair of beams, 6 deck supports and choice of deck. 18" depth do not include deck supports.

W" x D"	NO DECK Model	WOOD DECK Model	WIRE DECK Model	STEEL DECK Model
60 x 18	SC504530A	SC504590A	---	---
60 x 24	SC504407A	SC504281A	SC504464A	SC504344A
60 x 36	SC504408A	SC504282A	SC504465A	SC504345A
60 x 48	SC504409A	SC504283A	SC504466A	SC504346A
72 x 18	SC504531A	SC504536A	SC504542A	---
72 x 24	SC504410A	SC504284A	SC504467A	SC504347A
72 x 36	SC504411A	SC504285A	SC504468A	SC504348A
72 x 48	SC504412A	SC504286A	SC504469A	SC504349A
96 x 18	SC504532A	SC504537A	SC504543A	---
96 x 24	SC504413A	SC504287A	SC504470A	SC504350A
96 x 36	SC504414A	SC504288A	SC504471A	SC504351A
96 x 48	SC504415A	SC504289A	SC504472A	SC504352A

THE GLOBAL DIFFERENCE

Global Racks Are Built Better. Here's Why:

BEAMS		UPRIGHTS	
THEIRS	OURS	THEIRS	OURS
TWO 1/2" HOOKS .068" THICK	THREE LARGE 1" HOOKS FOR POSITIVE FIT .0785" THICK	BOX FORMED WITH 4 BENDS	ROLL FORMED WITH 8 BENDS FOR EXTRA STRENGTH
BEAMS			
THEIRS	OURS		
3"H	3 1/2"H		
THEIR BEAMS	OUR BEAMS		

BEAMS-12 gauge. Gray powder coat finish.			DECK SUPPORTS - Powder coat		STEEL DECK- Galvanized.	
L"	lbs./pair	Model	D"	Model	W" x D"	Model
60	3800	SC504560	24	SC504549	12 x 24	SC504563
72	2750	SC504561	36	SC504566	12 x 36	SC504564
96	2150	SC504562	48	SC504567	12 x 48	SC504565

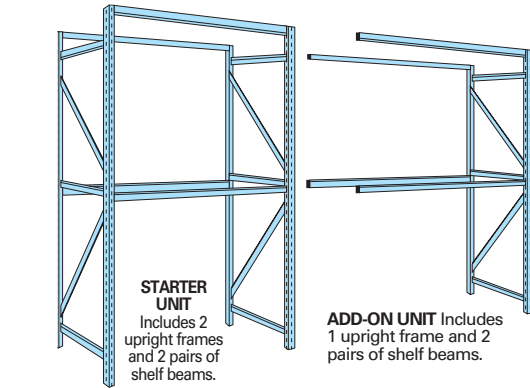

W" x D"	Beam Ht.	Cap. Pair	STARTER Model	ADD-ON Model
8' HIGH				
48 x 36	3 ⁵ / ₁₆	6590	SC796560	SC796561
96 x 36	4 ¹ / ₃₂	5030	SC796562	SC796563
96 x 36	5 ¹ / ₈	7160	SC796564	SC796565
108 x 36	5 ¹ / ₈	6420	SC796566	SC796567
120 x 36	5 ¹ / ₈	5630	SC796568	SC796569
48 x 42	3 ⁵ / ₁₆	6590	SC796570	SC796571
96 x 42	4 ¹ / ₃₂	5030	SC796572	SC796573
96 x 42	5 ¹ / ₈	7160	SC796574	SC796575
108 x 42	5 ¹ / ₈	6420	SC796576	SC796577
120 x 42	5 ¹ / ₈	5630	SC796578	SC796579
48 x 48	3 ⁵ / ₁₆	6590	SC796580	SC796581
96 x 48	4 ¹ / ₃₂	5030	SC796582	SC796583
96 x 48	5 ¹ / ₈	7160	SC796584	SC796585
108 x 48	5 ¹ / ₈	6420	SC796586	SC796587
120 x 48	5 ¹ / ₈	5630	SC796588	SC796589

RIGID ROW SPACER

For uniform spacing between racks and pallets. 4"H.

Depth"	Model
6	SC796353
8	SC796354
12	SC796355

SHIMS FOR FRAMES

Model	L" x W"
SC796363	3 x 3 ³ / ₈
SC796364	3 x 4 ¹ / ₂

WRAP AROUND FRAME GUARD

Model	H"
SC798617	12
SC798618	18

GLOBAL® TEARDROP PALLET RACK

Premium Quality at a Low Price

Offers quick and easy, tool free assembly for all your pallet storage needs. Tear drop, snap-in locking slots ensure a secure and stable unit. Durable heavy 13 gauge steel one piece box-formed reinforced upright frame punched 2" on centers for maximum adjustability and 15 gauge beams for years of service. Positive six-way locking action; right to left; front to back; up/down. Lock automatically snaps into place and secures beam, is visible for easy checking and fast adjustment. Welded braces provide maximum rigidity and stability. Epoxy finish. Step down beam design accommodates cross bars and decking. **Interchangeable with Teardrops styles of the following manufacturers:** Interlake, Kingway, Unarco, Steel King, USP, Wireway/Husky and Speed Rack. 3¹/_{4"} x 4¹/_{4"}, 12 ga. base plate anchors upright to floor and distributes weight evenly.

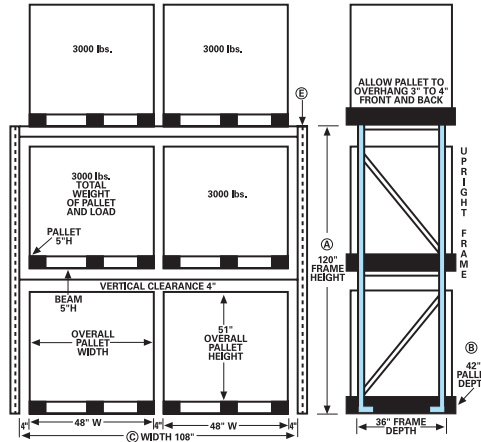

HOW TO SELECT PALLET RACK:

- Height:** Measure all verticals including height of pallet, pallet-load, beam, add an extra 4" to 8" clearance between top of load and bottom of beam above. Top beam should be a minimum of 6" less than the lifting height of your forklift.
- Depth:** Measure depth of pallet. Pallet should overhang frame by 3" front and back. (eg.: 48" deep pallet, use 42" deep frame.)
- Width:** Measure width of pallet, add a minimum of 3" clearance pallet to frame and 4" between pallets to determine correct beam length. Each pair of beams must support weight of pallets per level.
- Frame Capacity:** Add total weight of all pallets for each bay (exclude pallets on floor.) This is your desired frame capacity.
- E.** A common frame should be used between each section.

UPRIGHT FRAME (GREEN)

Frame H" x D"	Model
3" x 1⁵/_{8"} COLUMN 23,400 LB. CAP.	
96 x 48	SC796346
96 x 36	SC796344
96 x 42	SC796345
120 x 42	SC796347
120 x 48	SC796348
144 x 36	SC796349
144 x 42	SC796350
144 x 48	SC796351
3" X 3" COLUMN 38,400 LB. CAP.	
192 x 42	SC796352

BEAMS (ORANGE)

One pair required per level.

Clear Span"	Cap. Lbs./Pr.	Beam Ht."	Model
48	6590	3 ⁵ / ₁₆	SC245970
96	3230	3 ⁵ / ₁₆	SC597001
96	5030	4 ¹ / ₃₂	SC245972
96	7160	5 ¹ / ₈	SC245973
108	6420	5 ¹ / ₈	SC245975
120	5630	5 ¹ / ₈	SC245976
144	5970	6	SC597007

FLOOR ANCHOR BOLTS 1/2" x 3/4" SC796365

UPRIGHT FRAME CAPACITIES (in lbs.)
Meets 2008 RMI and 2007 AISI specifications. Shelf spacing is measured from the floor to the top of the first beam or the maximum shelf spacing, whichever is greater.

Maximum Shelf Spacing"	Column Size" 3" x 1 ⁵ / _{8"}	Column Size" 3" x 3"
36	23,400	38,400
42	21,900	34,600
48	19,300	30,600
54	16,700	26,400
60	15,000	23,100
66	13,400	20,900
72	11,700	18,700
78	10,300	16,500
84	9,100	14,700
90	8,000	13,100
96	7,100	11,800

CROSS BAR

Supports decking and undersized pallets.

Frame Depth"	Cap. lbs.	Model
36	1350	SC796356
42	1130	SC796357
48	970	SC796358

STEEL WIRE MESH DECKING

Gray Enamel finish.



W'	D"	Cap.	Model
46	36	3200	SC613261
52	36	3250	SC613262
58	36	3300	SC613263
46	42	2700	SC613264
52	42	2700	SC613265
58	42	2750	SC613266
46	48	2550	SC613267
52	48	2600	SC613268
58	48	2650	SC613269

STEEL WIRE MESH DECKING

Capacity Lbs.	Length Left/Right"	A		B	Model
		Depth Front/Back"	Between Step"		
2,700	46	36	32 1/2	32 1/2	SC798651
2,500	46	42	32 1/2	32 1/2	SC798654
2,500	46	48	32 1/2	32 1/2	SC798657
2,750	52	36	38 1/2	38 1/2	SC798652
2,700	52	42	38 1/2	38 1/2	SC798655
2,500	52	48	38 1/2	38 1/2	SC798658
2,800	58	36	38 1/2	38 1/2	SC798653
2,750	58	42	38 1/2	38 1/2	SC798756
2,500	58	48	38 1/2	38 1/2	SC798659

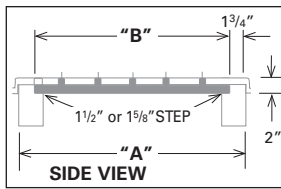

Strong, 2 1/2" x 4" welded wire features three 13-gauge channel supports. Permits light, air and sprinkler penetration; and minimizes dust accumulation. Simply drop into place over beams. Use with beams that have 1 1/2" or 1 5/8" step. Oven baked gray enamel finish.



TO ORDER:

Measure beam length between uprights (left-to-right)
 Measure beam depth overall (front-to-back)
 Measure depth between beam steps (front-to-back)

Beam Length"	Use	Beam Length"	Use
96	Two 46"	120	Two 58"
108	Two 52"	144	Three 46"

10,000 lb. HIGH CAPACITY REEL RACK



Adjustable for up to 60" diameter reels. Axle brackets accommodate up to 2" diameter axles for 2000 lb. capacity per pair. Safety pins lock axle brackets and cross beams to upright frames. 12 gauge steel upright frames measure 3 1/2" W x 3" D. Durable 10 gauge steel axle brackets. Cross beams and brackets adjust on 3" centers. **Starter Unit** includes 2 upright frames with brace set, 2 pairs cross beams, 4 pairs axle brackets. **Add-on** is same as starter except includes one upright frame. **Axle Kit** includes two 1" and two 1 7/8" diameter axles. Gray powder coat finish. Easy assembly.

AXLE KIT		Base D"x W"x H"	STARTER Model	ADD-ON Model
24	SC653193	24 x 24 x 96	SC653171	SC653182
36	SC653194	24 x 36 x 96	SC653172	SC653183
48	SC653195	24 x 48 x 96	SC653173	SC653184
		36 x 24 x 96	SC653174	SC653185
		36 x 36 x 96	SC653175	SC653186
		36 x 48 x 96	SC653176	SC653187
		24 x 24 x 120	SC653177	SC653188
		24 x 36 x 120	SC653178	SC653189
		24 x 48 x 120	SC653179	SC653190
		36 x 36 x 120	SC653180	SC653191
		36 x 48 x 120	SC653181	SC653192

GRAVITY FLOW CARTON RACK



Provides first-in-first-out rotation. Roller tracks have U-shaped galvanized steel channel sides with plastic wheels that support 50 lbs./ft. Guide rails and beams adjust to accommodate carton sizes. Each level includes 4 pairs of roller tracks, 5 guide rails and 1 cross support. 5/8" thick particle board top shelf supports 1000 lbs. of storage. Levels adjust on 1 1/2" centers. Gray baked enamel finish. Easy assembly.

W" x D" x H"	Gravity Levels	Model
SINGLE DEPTH UNIT		
96 x 36 x 84	3	SC184054
96 x 36 x 84	4	SC184055
96 x 36 x 84	5	SC184056
96 x 48 x 84	3	SC184057
96 x 48 x 84	4	SC184058
96 x 48 x 84	5	SC184059
DOUBLE DEPTH UNIT: Bolted front to back		
96 x 72 x 84	3	SC235391
96 x 72 x 84	4	SC235392
96 x 72 x 84	5	SC235393
96 x 84 x 84	3	SC235394
96 x 84 x 84	4	SC235395
96 x 84 x 84	5	SC235396
96 x 96 x 84	3	SC235397
96 x 96 x 84	4	SC235398
96 x 96 x 84	5	SC235399

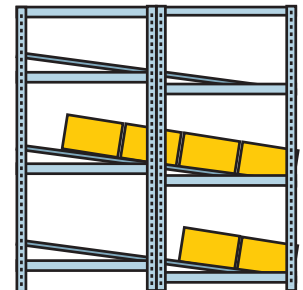

DOUBLE DEPTH

ADDITIONAL LEVELS		ADDITIONAL ROLLERTRACKS	
Include supports, rollertracks and guide rails			
W" x D"	Model	D"	Model
96 x 36	SC653275	36	SC184199
96 x 48	SC653276	48	SC184200
96 x 72	SC653277	72	SC235821
96 x 84	SC653278	84	SC235822
96 x 96	SC653279	96	SC235823

MOBILE REEL DISPENSER

900 lb. capacity

Store, dispense and cut desired lengths of wire, cable, rope, etc. Each 40" long, 5/8" dia. axle holds 150 lbs. and adjusts on 7" centers. Tubular steel construction, 32" x 40" base with leveling glides for uneven surfaces. 66" high. Optional casters add 6 1/4" to height. Gray enamel finish. Assembles easily.

SHOWN WITH
OPTIONAL
CASTERS

Model
SC184632
SC184631

Description
6 axle reel dispenser
5" polyurethane swivel
brake caster set



WIRE REEL CADDY

Pays out wire quickly and easily. Designed for wire spools of assorted sizes. Includes 8 axles 3/4" diameter and 2 axles 1 1/8" diameter. Rugged 16 gauge welded steel frame is constructed of 3/4" tubing with durable powder coated bright orange finish.

Model
SC230002



SAFETY U-RACK

10,000 lb.
capacity per pair

Ideal for storing bars, channels, angles, pipes etc. Stacks up to 4 high. Safety pins lock stacked racks together to help protect employees from injury. Heavy duty welded steel construction. 25 1/4" wide top x 20" high x 4 1/4" wide bottom channel.

Model SC952201



STEEL PIN LOCKS
RACKS TOGETHER



VERTICAL SHEET RACK



Choice of Floor
or Mobile

Stores sheet materials. Includes 3 pairs of 1 3/16" dia. steel pipe uprights at 12", 26" and 36" heights steel framed wooden deck with lacquer finish. 1 1/2" H x 1/2" thick angle iron frame has rounded safety edges. Provisions included for floor anchoring. Blue enamel finish. **Frame sockets permit 3 1/2" upright adjustments** (24" W has 7 sockets; 30" W has 9 sockets). **Mobile Rack** has 6" mold-on rubber wheels and 2,000 lb. capacity.

L" x W"	FLOOR RACK	MOBILE RACK
	Model	Model
48 x 24	SC652208	SC652214
60 x 30	SC652213	SC652215

CORROSION RESISTANT CANTILEVER SHELVING & RACK

Offers 800 lb. capacity per pair of arms. Global's **Nexelon** finish protects against bacteria, mold, cold weather and chemicals. **10 Year Limited Lifetime Warranty against rust and corrosion.** 12 gauge steel frame adjusts to 36", 48", 60" or 72" W. Frame measures 72" H x 27" D and includes 27" D x 8-1/2" H bottom shelf. Allows arm adjustments at 6" increments. **Cantilever Shelving** includes frame, 3 pairs of straight arms and 3 wire shelves. **Wire Shelves** easily rest on straight arms. Configure your own **Cantilever Rack** using 1 **Frame** and 24" L **Straight Arms** to store square or flat items or 20" **Incline Arms** to store pipes and round stock.

Customize
to Your Bulk
Storage Needs!



WIRE
SHELVES

CANTILEVER RACK	
Model	Description
SC235947	Frame
SC235948	Straight Arms
SC235949	20" Incline Arms

W" x D"	CANTILEVER SHELVING	ADDITIONAL WIRE SHELVES
	Model	Model
36 x 24	SC245644	SC188556E
48 x 24	SC245645	SC188558E
60 x 24	SC245646	SC188560E
72 x 24	SC245647	SC188564E



NSF

27" BOTTOM SHELF
FOR SMALLER ITEMS

MODULAR PERIMETER WIRE FENCE PARTITIONS

Modular security partitions are ideal for protecting dangerous machinery, conveyor belts and electrical switchgear from wear and tear as well as theft. Provides a barrier between employees and potential hazards. Durable woven 10 gauge wire construction provides clear visibility. Partitions can be easily installed for quick removal or more permanently for maximum security with the hardware (sold separately). Panels measure 5'H and attach to post 1' above floor for sweep space. Easy to install, remove or expand. Bright yellow enamel finish.

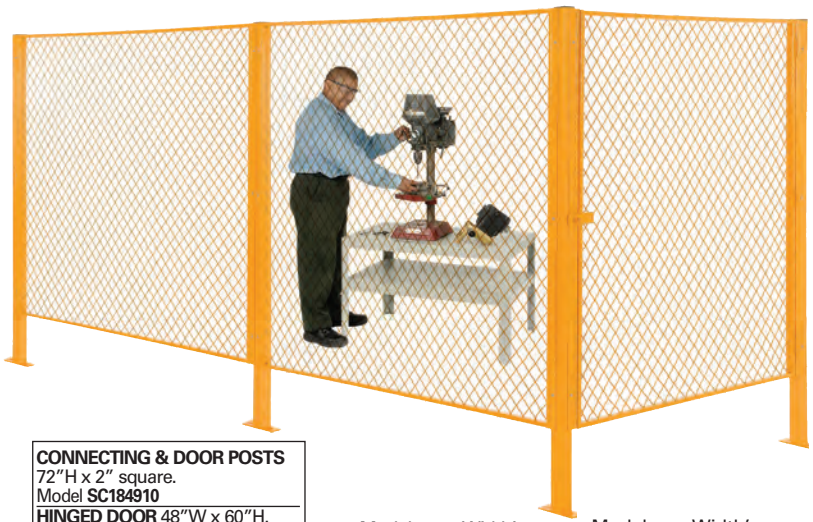

CONNECTING & DOOR POSTS
72"H x 2" square.
Model **SC184910**
HINGED DOOR 48"W x 60"H.
Includes lock hasp.
Model **SC184911**
HARDWARE KIT 100 pcs. of 10 x 3/4 slot hex washer type 'A'.
Model **SC270015**

Model	Width'	Model	Width'
SC184900	1	SC184905	6
SC184901	2	SC184906	7
SC184902	3	SC184907	8
SC184903	4	SC184908	9
SC184904	5	SC184909	10



COMPLETE WIRE MESH SECURITY ROOM

Convenient and Easy to Order!

Woven wire mesh security rooms provide security, safety, protection and access control. These pre-designed rooms are available with or without a roof, in two, three and four sided configurations. Constructed from high quality 10 gauge steel wire, woven into an extremely strong frame. Modular components makes installation easy, usually requires no change to existing heating, lighting or ventilating system. Components bolt together quickly and can be easily relocated. Long-lasting, maintenance-free powder coated gray enamel finish. Available in 8' and 10'H in five standard sizes ranging from 10'x10' to 20'x30'. All models include a 5'W x 8'H sliding gate with mortise cylinder lock.

OTHER SIZES AVAILABLE CALL 1-800-645-1232



BEST PRICE ANYWHERE!

SHOWN WITH OPTIONAL SERVICE WINDOW

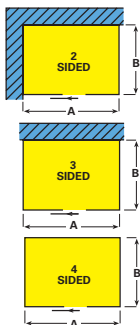

ROOM WITHOUT ROOF			ROOM WITH ROOF					
2 SIDES Model	3 SIDES Model	4 SIDES Model	A'	B'	C'	2 SIDES Model	3 SIDES Model	4 SIDES Model
SC603280	SC603290	SC603300	10	10	8	SC180250	SC180350	SC180450
SC603281	SC603291	SC603301	20	10	8	SC180252	SC180352	SC180452
SC603282	SC603292	SC603302	20	15	8	SC180254	SC180354	SC180454
SC603283	SC603293	SC603303	20	20	8	SC180256	SC180356	SC180456
SC603284	SC603294	SC603304	30	20	8	SC180258	SC180358	SC180458
SC603285	SC603295	SC603305	10	10	10	SC180260	SC180360	SC180460
SC603286	SC603296	SC603306	20	20	10	SC180262	SC180362	SC180462
SC603287	SC603297	SC603307	20	20	10	SC180264	SC180364	SC180464
SC603288	SC603298	SC603308	20	20	10	SC180266	SC180366	SC180466
SC603289	SC603299	SC603309	30	30	10	SC180268	SC180368	SC180468

SLIDING SERVICE WINDOW Mounted in 5' wide panel. Padlockable. Includes 12"D shelf. Add suffix **A** to any model above.

NEW AMAZING PRICE!
Never Compromise Quality for Price . . .
MORE FEATURES & QUALITY

WIRE MESH SECURITY PARTITION



**Lowest Price
 In The
 Industry!**



Exclusive Features Only At GLOBAL WIRE COMPONENTS

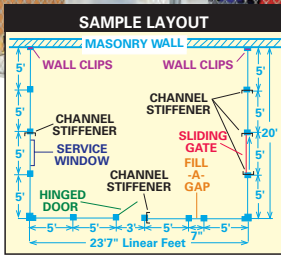

Global Exclusive Features Include:

- Free mortise cylinder lock in every door
- Free 3 1/2" W stiffener post with each door for superior strength

Create high-visibility security areas with our easy-to-install partitions. Designed for unrestricted ventilation and layout flexibility. Made of 10-gauge wire woven in a 1 1/2" diamond pattern with a strong 14-gauge cold rolled C-channel frame. Wire mesh is clinched, not welded, into frame for heavy-duty strength and enhanced appearance. Panels include floor sockets, nuts, bolts and detailed assembly instructions. Gray powder coat finish.

Easy To Assemble!



TOP CAPPING FOR ROOMS WITHOUT ROOF



MOUNTING ANGLE FOR ROOMS WITH ROOF

REMEMBER TO ORDER TOP CAPPING

Width' PANEL	8' HIGH Model	10' HIGH Model
1	SC603320	SC603325
2	SC603321	SC603326
3	SC603322	SC603327
4	SC603323	SC603328
5	SC603324	SC603329

FILL-A-GAP ADJUSTABLE PANEL 1 1/2" - 12"	SC603330	SC603331
HINGED DOOR with cylinder lock - 8'H (10' H room has 2'H transom) Includes 3 1/2" W channel stiffener.	SC603332 SC603333	SC603334 SC603335
SLIDING GATE with cylinder lock - 8'H (10' H room has 2'H transom) Includes three 3 1/2" W channel stiffeners.	SC603336 SC603337 SC603338 SC603339	SC603340 SC603341 SC603342 SC603343

*TOP CAPPING: 10' length of top capping (see ordering instructions).
 SC603146

CORNER POST
 SC603344 SC603345

CHANNEL STIFFENER POST Recommended every 2 panels.
 SC603346 SC603347

T-SPLICE: joint 3 panels in "T" configuration.
 SC603130

SLIDING SERVICE WINDOW Includes 12" D shelf.
 Mounted in 5' wide Panel. Padlockable.
 SC603348 SC603349

WALL CLIPS one set required for each wall connection.
 SC603350

FLOOR SOCKET Anchors panel.
 SC237623

ROOF PANEL Including hardware.
 1' x 10' SC240761
 5' x 10' SC240720

MOUNTING ANGLE FOR ROOF PANEL 1 required per panel.
 10' SC240721

ROOF BEAM
 10' SC240722
 ROOF BEAM SPLICE KIT
 SC240723

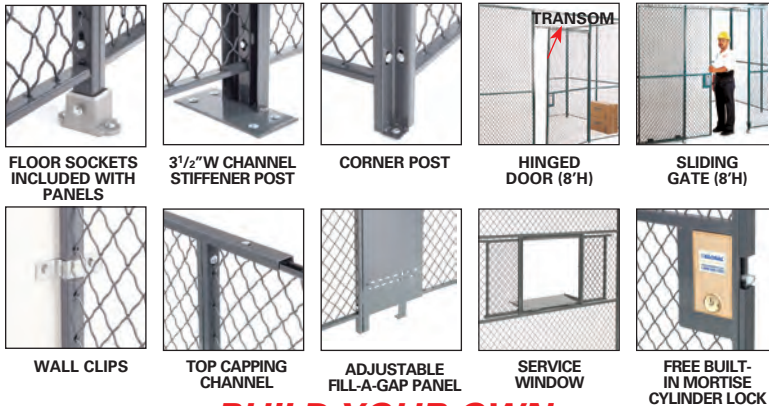

BUILD YOUR OWN

EASY TO PLAN AND ORDER:

1. Make a floor plan including measurements. Determine height of partition.
2. Indicate doors, gates and service windows and their size and location. Show the direction of the gate slide or door hinges either left- or right-handed and swinging in or out.
3. Be sure to utilize as many 5 ft. wide panels as possible for most efficient pricing. Add one channel stiffener post for every 2 panels. (Stiffener posts are included with each door and gate.)
4. **Important: You must order TOP CAPPING** in 10-foot sections. Calculate the total linear feet and round up to the nearest multiple of 10, then divide by 10 for the number of top capping sections. Example: Actual 63' 7" linear feet: Order 7 top capping sections (70 ft. total).
5. Adding a roof requires 1 ft. or 5 ft. roof panels (hardware included) and mounting angles. Rooms larger than 20' x 10' require a 10'L roof beam. Roof beams can be joined together by using a splice kit when beam requirements exceed 10'L and a channel stiffener post is required to support connected roof beams.

ENHANCED VISIBLE SECURITY CAGE

Ventilated Wide Span Bulk Storage Lockers are made with a 3" x 3" x 1/4" thick wire mesh with gray epoxy finish to minimize dust accumulation and maximize visibility for simple inventory control. Lockers include one height-adjustable shelf with 600 lb. capacity. Shelf adjusts in 3" increments. Improved latch design to accept padlock. For enhanced security, install shelf at center position to allow use of included padlock. Double doors are welded to side panels and are flush against unit top. Door hinges swing open 270° for full access to interior. Easy assembly. Choose from a variety of sizes. Additional shelves sold separately.

CAGE WITH DOORS		ADDITIONAL SHELF
Model	W" x D" x H"	Model
SC184083	36 x 24 x 36	SC184106
SC184084	36 x 24 x 48	
SC184085	36 x 24 x 60	
SC184086	36 x 24 x 72	
SC184087	48 x 24 x 36	SC184107
SC184088	48 x 24 x 48	
SC184089	48 x 24 x 60	
SC184090	48 x 24 x 72	
SC184092	60 x 24 x 60	SC184108
SC184093	60 x 24 x 72	SC184109
SC184095	72 x 24 x 60	
SC184096	72 x 24 x 72	
SC184097	48 x 36 x 48	
SC184098	48 x 36 x 60	SC184110
SC184099	48 x 36 x 72	SC184111
SC184100	60 x 36 x 48	
SC184101	60 x 36 x 60	
SC184102	60 x 36 x 72	
SC184104	72 x 36 x 60	SC184112
SC184105	72 x 36 x 72	



SC184089

CAPITAL STEEL LOCKERS

Best Price Anywhere!
Withstands Everyday Abuse



SC652138GY

SC652147GY



COAT ROD



FIVE KNUCKLE HINGES WITH LAPPED AND WELDED STEEL DOOR FRAME

EASY GRIP RECESSED HANDLE FOR QUICK ACCESS

Quiet Operation and an Excellent Value



Online Video & Photos



CATCH-FREE RECESSED HANDLE

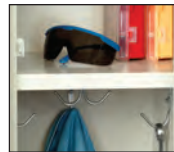

HAT SHELF AND COAT HOOKS



SC652141TN

Our Capital lockers provide performance and reliability. Reinforced, welded frame-and-door assemblies ensure maximum security. Doors are styled with a catch-free recessed handle and padlockable friction hasp for quiet operation and ventilated with 2 sets of louvers. Durable powder coat finish resists wear and scratches for years of attractive service. Legs add 6" to height. Includes blank number plates. Optional locks, numbered plate kits and bases sold separately. Choose from tan or gray and assembled or ready-to-assemble styles. **Single Tier** lockers include a hat shelf and double and single-prong coat hooks (the 18" deep model also includes coat rod). **Double Tier** lockers include double and single-prong coat hooks. **Assembled lockers are not returnable.**

Opening W" x D" x H"	Overall Width"	Doors	Wt. Lbs.	READY TO ASSEMBLE Model*	ASSEMBLED Model*
SINGLE TIER					
12 x 15 x 72	12	1	50	SC652038	SC652138
12 x 15 x 72	36	3	147	SC652039	SC652139
12 x 18 x 72	12	1	53	SC652040	SC652140
12 x 18 x 72	36	3	162	SC652041	SC652141
DOUBLE TIER					
12 x 15 x 36	12	2	52	SC652046	SC652146
12 x 15 x 36	36	6	149	SC652047	SC652147
12 x 18 x 36	12	2	55	SC652048	SC652148
12 x 18 x 36	36	6	162	SC652049	SC652149

*All models: specify color suffix Gray (GY) or Tan (TN)

Accessories

CLOSED BASE End Base includes left and right sides.

Model*	Description
SC652080A	12"W Front Base
SC652083A	15"D End Base
SC652084A	18"D End Base



NUMBERED PLATE KITS

Numbered aluminum plates. Includes rivets. Model SC652095A includes rivet gun.

Model	Description
SC652095A	Numbered 1-100
SC652717A	Numbered 101-299
SC652718A	Numbered 300-499



SLOPE TOP KITS

Up to 3 lockers wide. Includes 3 tops, 2 sides and 3 backs. 6 3/4" Height.

Model*	Opening Width"	Depth"
SC652705A	12	12
SC652706A	12	15
SC652707A	12	18
SC652708A	15	18

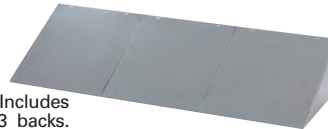

LOCK
Model Description
SC959101X Keyed Padlock (includes 2 keys)



PARAMOUNT® PREMIUM



Model SC652170TN
(6 WIDE) SHOWN WITH
OPTIONAL CLOSED BASE
AND BUILT-IN COMBO LOCK

The Paramount series lockers feature 16 gauge steel doors, 5-knuckle security hinges, quiet operating latch mechanism, and welded, reinforced frame-and-door assemblies for maximum security. Extra wide louvers promote ventilation. Legs add 6" to height. Durable, attractive powder coat finish is available in the 3 most popular locker colors: blue, tan and gray. Includes blank number plates. Lockers feature finished sides; no need for decorative end panels. Optional locks, numbered plate kits and bases sold separately. **Assembled lockers are not returnable.**

Single Tier lockers have secure 3-point positive locking system, hat shelf, chrome door latch and double and single-prong coat hooks (18" deep model also includes coat rod).

Double Tier & Triple Tier lockers have secure 2-point positive locking system, chrome door latch and double and single prong coat hooks. **Six Tier** Lockers feature padlockable friction latch and hasp closures.

Sixteen Person lockers featured the same as **six tier** and are arranged around a central coat rod. Each compartment is 12"W x 18"D x 12"H.



Model
SC652174TN



Model
SC238233TN



CHROME DOOR
LATCH FOR SMOOTH
FINGERTIP OPENING



FIVE KNUCKLE
HINGES WITH
LAPPED AND
WELDED STEEL
DOOR FRAME

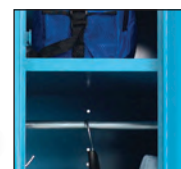

HAT SHELF AND
COAT ROD

Opening W" x D" x H"	Overall Width"	Doors	Wt. lbs.	READY TO ASSEMBLE Model*	ASSEMBLED Model*
Single Tier					
12 x 12 x 60	12	1	43	SC652060	SC652160
12 x 12 x 60	36	3	133	SC652061	SC652161
12 x 15 x 60	12	1	47	SC652062	SC652162
12 x 15 x 60	36	3	140	SC652063	SC652163
12 x 18 x 60	12	1	52	SC652064	SC652164
12 x 18 x 60	36	3	154	SC652065	SC652165
12 x 12 x 72	12	1	46	SC652066	SC652166
12 x 12 x 72	36	3	144	SC652067	SC652167
12 x 18 x 72	12	1	55	SC652070	SC652170
12 x 18 x 72	36	3	167	SC652071	SC652171
15 x 18 x 72	15	1	66	SC652072	SC652172
15 x 18 x 72	45	3	181	SC652073	SC652173

*All models: specify color suffix Blue (BL), Gray (GY) or Tan (TN)



LOCK Model	Description
SC959101V	Keyed Padlock (includes 2 keys)
LOCKS FROM MASTER LOCK®	
SC652867D	Combo Padlock
SC652864A	Built-In Combo Lock (single/double/triple tier)
SC652868A	Built-In Combo Lock (six tier)
SC652880	Built-In Cylinder Lock (single/double/triple tier)
SC652879A	Built-In Cylinder Lock (six tier)

Accessories



SLOPE TOP KITS

Up to 3 lockers wide. Includes 3 tops, 2 sides and 3 backs. 6 3/4" Height. Does not work on 16-person lockers.

Model*	Opening Width"	Depth"
SC652705	12	12
SC652706	12	15
SC652707	12	18
SC652708	15	18

CLOSED BASE End Base includes left and right sides.

Model*	Description
SC652080	12"W Front Base
SC652081	15"W Front Base
SC652082	12"D End Base
SC652083	15"D End Base
SC652084	18"D End Base



NUMBERED PLATE KITS

Numbered aluminum plates. Includes rivets. Model DP652095 includes rivet gun.

Model	Description
SC652095	Numbered 1-100
SC652717	Numbered 101-299
SC652718	Numbered 300-499



STEEL LOCKERS

Top Quality at an Unbelievable Price!



Model
SC652155BL



Model
SC238235TN



Built Strong for Tough Working Environments

Opening W"x D" x H"	Overall Width"	Doors	Wt. lbs.	READY TO ASSEMBLE	ASSEMBLED	Opening W"x D" x H"	Overall Width"	Doors	Wt. lbs.	READY TO ASSEMBLE	ASSEMBLED
				Model*	Model*					Model*	Model*
Double Tier											
12 x 12 x 36	12	2	51	SC652074	SC652174	12 x 12 x 12	12	6	54	SC652054	SC652154
12 x 12 x 36	36	6	153	SC652075	SC652175	12 x 12 x 12	36	18	161	SC652055	SC652155
12 x 15 x 36	12	2	55	SC652076	SC652176	12 x 15 x 12	12	6	65	SC652056	SC652156
12 x 15 x 36	36	6	159	SC652077	SC652177	12 x 15 x 12	36	18	175	SC652057	SC652157
12 x 18 x 36	12	2	58	SC652078	SC652178	12 x 18 x 12	12	6	72	SC269690	SC269692
12 x 18 x 36	36	6	172	SC652079	SC652179	12 x 18 x 12	36	18	197	SC269691	SC269693
Triple Tier											
12 x 15 x 24	12	3	56	SC238230	SC238233	12 x 18 x 12	69	16	168	SC238232	SC238235†
12 x 15 x 24	36	9	161	SC238231	SC238234						

*All models: specify color suffix Blue (BL), Gray (GY) or Tan (TN)

*All models: specify color suffix Blue (BL), Gray (GY) or Tan (TN)

†Ships partially assembled.

Accessories

Model	Length'
SC183670N	6
SC183672N	8
SC183674N	9
SC183676N	10

LOCKER BENCH

1 1/4" thick hardwood has heavily varnished clear top for splinter-free sitting. Mounted on two heavy steel pedestals - 9 ft. and 10 ft. models have three pedestals. 9 1/2"W x 18"H. **MUST BE ANCHORED TO FLOOR FOR MAXIMUM STABILITY.**

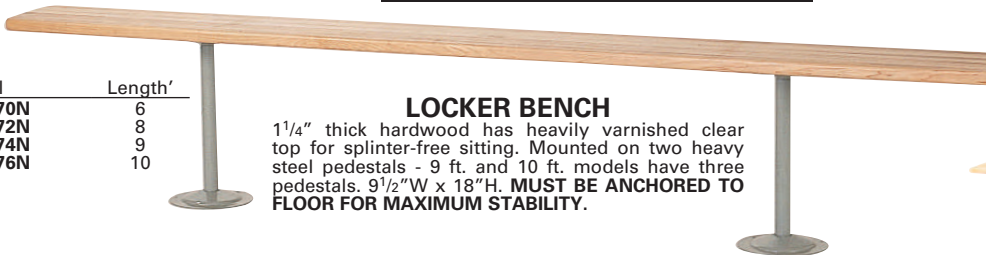

01-800-467-0529

chproductos.com

47



INFINITY STEEL LOCKERS

Contemporary Styling with Superior Security



SC968251GY

NYLON CATCH FOR QUIET DOOR OPERATION



SC652970TN



RECESSED STAINLESS STEEL HANDLE FOR SAFETY AND APPEARANCE



SC968264BL



Catch-Free Recessed Handle Enhances Safety and Security Door handle with fingertip lift latch is recessed into the door face to create a smooth catch-free surface, to discourage the padlock from being cut off and to provide a neat, clean look. The results are quiet operation and improved safety, security and appearance. These quality lockers feature 16 gauge steel doors, 5-knuckle security hinge and welded, reinforced frame-and-door assemblies. Extra wide louvers promote ventilation. Legs add 6" to height. Includes blank number plate. Optional locks, numbered plate kits and bases sold separately. Durable, attractive powder coat finish is available in the 3 most popular locker colors; add color suffix: Gray (GY), Tan (TN) and Blue (BL). Assembled lockers are not returnable.

Single Tier lockers have secure 3-point positive locking system, hat shelf, stainless steel door latch and double and single-prong coat hooks (the 18" deep model also includes coat rod).

Double Tier lockers have secure 2-point positive locking system, stainless steel door latch and double and single-prong coat hooks.

Six Tier lockers feature padlockable friction latch and hasp closures.

Sixteen Person lockers feature the same as **Six Tier** and are arranged around a central coat rod. Each compartment is 12"W x 18"D x 12"H.

Opening W" x D" x H"	Overall Width"	Doors	Wt. Lbs.	READY TO ASSEMBLE Model*	ASSEMBLED Model*
SINGLE TIER					
12 x 12 x 60	12	1	43	SC254109	SC968250
12 x 12 x 60	36	3	133	SC254110	SC968251
12 x 15 x 60	12	1	47	SC254111	SC968252
12 x 15 x 60	36	3	140	SC254112	SC968253
12 x 18 x 60	12	1	52	SC254113	SC968254
12 x 18 x 60	36	3	154	SC254114	SC968255
12 x 12 x 72	12	1	46	SC254115	SC968256
12 x 12 x 72	36	3	144	SC254116	SC968257
12 x 18 x 72	12	1	55	SC254119	SC968260
12 x 18 x 72	36	3	167	SC254120	SC968261
15 x 18 x 72	15	1	66	SC254121	SC968262
15 x 18 x 72	45	3	181	SC254122	SC968263
DOUBLE TIER					
12 x 12 x 36	12	2	51	SC254123	SC968264
12 x 12 x 36	36	6	153	SC254124	SC968265
12 x 15 x 36	12	2	55	SC254125	SC968266
12 x 15 x 36	36	6	159	SC254126	SC968267
12 x 18 x 36	12	2	58	SC254127	SC968268
12 x 18 x 36	36	6	172	SC254128	SC968269
SIX TIER					
12 x 12 x 12	12	6	54	SC652965	SC652969
12 x 12 x 12	36	18	161	SC652966	SC652970
12 x 15 x 12	12	6	65	SC652967	SC652971
12 x 15 x 12	36	18	176	SC652968	SC652972
12 x 18 x 12	12	6	72	SC269694	SC269696
12 x 18 x 12	36	18	197	SC269695	SC269697
SIXTEEN PERSON					
12 x 18 x 12	69	16	168	SC239449	SC239450†

† Ships Partially Assembled

*All models: add color suffix: Blue (BL), Tan (TN) and Gray (GY)

LOCK

Model	Description
SC959101W	Keyed Padlock (includes 2 keys)



SLOPE TOP KITS

Up to 3 lockers wide. Includes 3 tops, 2 sides and 3 backs. 6¾" height. Does not work on 16-person lockers.

Model*	Opening Width"	Depth"
SC652705B	12	12
SC652706B	12	15
SC652707B	12	18
SC652708B	15	18

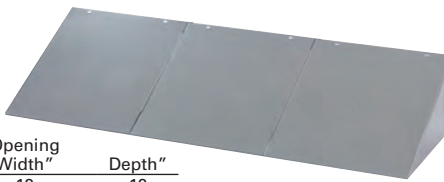

Accessories

CLOSED BASE End base includes left and right sides.

Model*	Description
SC652080B	12"W Front Base
SC652081B	15"W Front Base
SC652082B	12"D End Base
SC652083B	15"D End Base
SC652084B	18"D End Base

NUMBERED PLATE KITS

Numbered aluminum plates. Includes rivets. Model DP652095B includes rivet gun.

Model	Description
SC652095B	Numbered 1-100
SC652717B	Numbered 101-299
SC652718B	Numbered 300-499



Global ventilated lockers are made using heavy 16 gauge steel with diamond shaped perforations for improved airflow. Locker doors feature rubber bumpers on framing to ensure quiet operation. Continuous piano hinges provide maximum security. Recessed handle and finger-lift control creates a clean, neat appearance. Lockers include blank number plates. Gray Powder coat color finishes. Steel lockers feature finished sides; no need for decorative end panels. Legs add 6" to overall height. Optional locks and numbered plate sold separately. **Assembled lockers are not returnable.** **Single Tier lockers** feature stainless steel door latch, hat shelf and double and single-prong coat hooks (18"D Lockers also includes a coat rod). **Double Tier lockers** feature stainless steel door latch and double and single-prong coat hooks. **Six Tier Box Lockers** feature recessed handles and pad-lockable friction hasp closures.

Opening W" x D" x H"	Overall Width"	Doors	Wt. Lbs.	READY TO ASSEMBLE Model	ASSEMBLED Model
SINGLETIER					
12 x 12 x 72	12	1	81	SC493142GY	SC493242GY
12 x 18 x 72	12	1	99	SC493143GY	SC493243GY
12 x 12 x 72	36	3	183	SC493144GY	SC493244GY
12 x 18 x 72	36	3	225	SC493145GY	SC493245GY
DOUBLETIER					
12 x 12 x 36	12	2	86	SC493146GY	SC493246GY
12 x 15 x 36	12	2	97	SC493147GY	SC493247GY
12 x 18 x 36	12	2	106	SC493148GY	SC493248GY
12 x 12 x 36	36	6	197	SC493149GY	SC493249GY
12 x 15 x 36	36	6	210	SC493150GY	SC493250GY
12 x 18 x 36	36	6	242	SC493151GY	SC493251GY
SIXTIER					
12 x 12 x 12	12	6	101	SC493152GY	SC493252GY
12 x 15 x 12	12	6	112	SC493153GY	SC493253GY
12 x 18 x 12	12	6	125	SC493154GY	SC493254GY
12 x 12 x 12	36	18	211	SC493155GY	SC493255GY
12 x 15 x 12	36	18	234	SC493156GY	SC493256GY
12 x 18 x 12	36	18	247	SC493157GY	SC493257GY

GLOBAL INFINITY HEAVY DUTY VENTILATED STEEL LOCKERS



LOCKER BENCHES



A. FREE STANDING 1¹/₈" thick gray plastic top with safety rounded radius corners and black bullnose edging. Rugged steel pedestal with gray enamel finish. 12"W x 18"H. Easily assembled.

Length'	Model
6	SC702908
8	SC702910



B. & C. 1¹/₄" thick MAPLE HARDWOOD BENCH top and sturdy steel base. 17"H x 9¹/₂" W. 8 ft., 9 ft., and 10 ft. long benches have three pedestals. **B** anchor to the floor for maximum stability. Steel pedestals Gray enamel finish. **C** free standing STAINLESS STEEL 14"W base.

Length'	B. Model	C. Model
6	SC183670	SC184992
8	SC183672	SC184993
9	SC183674	SC184994
10	SC183676	SC184995



GLOBAL CELL PHONE LOCKERS



Cell Phone Lockers provide a convenient, secure, space saving solution for storing electronic device safely. Made with 21 gauge steel doors and 20 gauge body with black powder coat finish for long lasting durability. Mounted to the wall for ease of use, or placed on any flat surface, suggest to fasten to a wall to prevent tipping. Lockers equipped with high security key lock provide additional security. 12 sets of 2 keys per door; each door is keyed differently. Management has master key set to allow immediate access to all locker compartments as needed. Cell phone lockers are ideal for military facilities, law enforcement, government contractors, fitness clubs, swimming pools, health care and schools to securely store cell phone, tablets, wallets, sun glasses, keys and other personal items. Name plates and blank paper inserts, control sheet, hardware and mounting brackets included. Ships fully assembled.

Overall W" x D" x H"	Compartment W" x D" x H"	Opening W" x H"	Openings	Model
28 ¹ / ₂ x 11 ¹ / ₄ x 38	5 ⁹ / ₁₆ x 10 x 11 ¹ / ₂	5 x 10	12	SC270150BK
32 ¹ / ₈ x 10 ¹ / ₈ x 46 ¹ / ₁₆	6 ¹³ / ₁₆ x 8 ⁷ / ₈ x 6 ¹³ / ₁₆	5 ⁹ / ₁₆ x 6 ⁹ / ₁₆	24	SC270151BK

PARAMOUNT® INDUSTRIAL STORAGE CABINETS

Choose 36" or 48" Wide, Assembled or Easy To Assemble

CHANNEL REINFORCED, BOX FORMED DOORS

300 LB. SHELF CAPACITY



A

NYLON GLIDES FOR SMOOTH & QUIET OPERATION

SC603600GY



B

SC269878TN COMBINATION CABINET



C

SC269870GY COUNTER HEIGHT CABINET

ADDITIONAL SHELVES	
Shelves Model	Cabinet Model
SC237517	SC603355
SC237650	SC603599
SC493314	SC493310
SC493316	SC493312
SC493315	SC493311
SC493317	SC493313
SC237518	SC603557
SC237651	SC603600

Durable powder coat finish. Add color suffix: Black (BK), Tan (TN) or Gray (GY). Assembled Cabinets are non-returnable.

5 Ways Paramount® Cabinets Beat the Competition

Feature for feature, Paramount is strongest where theirs are not. Paramount doors have extra large 4" barrel hinges with 3/8" pins; their hinges are only 2 1/4" with 1/8" pins. Paramount shelves are box formed on all sides with dual channel reinforcements to maintain their shape; theirs are a single flat layer prone to sagging when loaded. The Paramount 5/16" round latching rods resist prying; their 3/32" flat rods can bend when doors are forced. The Paramount 48C base is supported with an I-beam for rigidity; their base allows the cabinet to flex, affecting proper door closure. Paramount includes 2 door handles for ease of closing.

1

OUR EXCLUSIVE 4" x 3/8" HINGES PROVIDE EXTRA DURABILITY

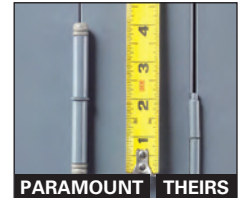

PARAMOUNT THEIRS

2

BOX FORMED CHANNEL REINFORCED SHELVES ADJUST ON 2" CENTERS

3

3 POINT LATCHING SYSTEM WITH SOLID STEEL 5/16" ROD



PARAMOUNT THEIRS



PARAMOUNT THEIRS

4

48" BASE IS I-BEAM REINFORCED FOR ADDED STRENGTH

5

EXCLUSIVE DUAL CHROME DIECAST KEY LOCKING HANDLE



PARAMOUNT THEIRS



THEIRS

W" x D" x H"	Openings/ Shelves	Color	UNASSEMBLED Model	ASSEMBLED Model
STYLE A: STORAGE CABINETS, LEVER HANDLE				
36 x 18 x 78	5 / 4	GY,BK,TN	SC603355	SC603599
36 x 24 x 78	5 / 4	GY,BK,TN	SC493310	SC493312
48 x 18 x 78	5 / 4	GY,BK,TN	SC493311	SC493313
48 x 24 x 78	5 / 4	GY,BK,TN	SC603357	SC603600
STYLE B: COMBINATION CABINETS, RECESSED HANDLE				
36 x 18 x 72	—	GY,BK,TN	SC269878	SC269879
STYLE C: COUNTER HEIGHT CABINETS, LEVER HANDLE				
36 x 18 x 42	3 / 2	GY	SC269870	SC269871
36 x 24 x 42	3 / 2	GY	SC269872	SC269873

PARAMOUNT® WALL MOUNT CABINETS



SC270019WH



SC269876GY



SC269877GY

Create secure locking storage at eye level for valuable equipment, first aid items, sensitive data or inventory. Rugged all-welded construction. Shipped assembled. Model SC269877 has a built in Document Pocket. Clear View Cabinet has a high-impact acrylic window that provides easy visibility of contents. Attractive scratch and chip resistant finish. **Add color suffix: Dark Gray (GY) or Off White (WH).**

Model	W" x D" x H"	Door	Adj. Shelves	Color Suffix
SOLID FRONT DOORS, RECESSED HANDLE				
SC269874	13 ³ / ₄ x 12 ³ / ₄ x 30	1	2	GY,WH
SC269877	19 ⁷ / ₈ x 14 ¹ / ₄ x 32 ³ / ₄	1	2	GY,WH
SC269875	18 x 12 x 26	1	2	GY,WH
SC269876	30 x 12 x 30	2	2	GY,WH
CLEAR VIEW DOORS, RECESSED HANDLE				
SC270017	13 ³ / ₄ x 12 ³ / ₄ x 30	1	2	GY,WH
SC270018	18 x 12 x 26	1	2	GY,WH
SC270019	30 x 12 x 30	2	2	GY,WH

STORAGE CABINET With Recessed Handle

Assembles With Only 4 Screws!
185 lb. Shelf Capacity



RECESSED LOCKING HANDLE



Global offers the best value on the market with improved features, easy assembly, and stronger, more durable construction. Ideal for storing office and industrial supplies, these storage cabinets are easy to assemble, with steel box formed doors for added strength. 3-point locking system with 5/16" thick locking rod adds strength and rigidity. Recessed locking handle with 2 keys for safety and security. Includes 4 height adjustable shelves with 185 lb. shelf capacity. Reinforced shelves adjust at 1/4" increments. Overall dimensions: 36"W x 18"D x 72"H. Durable powder coat finish. **Add color suffix: Gray (GY), Black (BK), or Tan (TN).**

CABINET	ADDITIONAL SHELVES (pkg. of 2)
Model	Model
SC237635	SC269840

PARAMOUNT® WARDROBE CABINETS

Wardrobe Cabinets are made of durable cold rolled steel using 24 gauge steel body reinforced with a 22 gauge steel frame. The channel reinforced, box formed doors include 3-point locking mechanism with a super strong 5/16" round locking bar and nylon guides for silent operation and consistent alignment. The cabinets feature one full width fixed shelf and one full width garment rod. Top Shelf allows storage of personal items. Recessed locking handle with 2 keys for safety and security. Durable powder coat finish. **Add color suffix : Gray (GY), Tan (TN) and Black (BK).**



SC270033TN

Chrome Coat Hangers, Pkg of 6 Model SC493306	W" x D" x H"	UNASSEMBLED		ASSEMBLED	
		Model	Model	Model	Model
	36 x 18 x 72	SC270031	SC270032	SC270033	SC270034

STAINLESS STEEL WALL & COUNTER HEIGHT CABINETS

Fully welded 18-gauge type 304 stainless steel for resistance to acid, corrosion and rust. Shelves adjust in 2" increments. Features stainless steel recessed paddle locking handle.



SCB592290

W" x D" x H"	Shelves	Adj. Cap. Lb.	Shelf Model
30 x 12 x 30	1	150	SCB592288

PARAMOUNT® SEE THRU CABINETS



SC237621



SC270020

Rugged door construction where it matters most! Doors have 3 extra large 4" x 3/8" barrel hinges each for security, 3-point locking system with pry-resistant solid steel 5/16" latching rods, and dual chrome plated die-cast key locking handles with 2 keys. Box-formed 36"W shelves have full width steel channel reinforcement (2 on 48"W) to help prevent shelf deflection. 4 adjustable shelves, hold 300 lbs. per shelf. **Clear View Storage Cabinets** feature channel reinforced impact resistant acrylic windows. **Expanded Metal Door Storage Cabinets** feature mesh door front to allow content visibility and ventilation. Add color suffix in **Gray (GY)**, **Tan (TN)** and **Black (BK)**.

W" x D" x H"	Color Suffix	EASY ASSEMBLY Model	ASSEMBLED Model
CLEAR VIEW CABINETS			
36 x 18 x 78	GY, TN	SC237614	SC237620
48 x 24 x 78	GY, TN, BK	SC237615	SC237621
EXPANDED METAL DOOR CABINETS			
36 x 18 x 78	GY, TN, BK	SC270020	SC270021
48 x 24 x 78	GY, TN, BK	SC270022	SC270023

"THE ORGANIZER" HEAVY DUTY CABINET



SC603314



38" CABINET HASP



48" CABINET HASP

All Welded

Assembled 16 gauge steel cabinets are finished in gray baked enamel and have 4 adjustable shelves. Pegboard panel on each door provides room for an array of equipment. Includes padlock hasp, leveling feet and assorted pegboard hooks... create a system that works with your equipment.

Model	W" x D" x H"	Description	Shelf Cap.
SC500336	38 x 24 x 72	60 Pegboard Hooks	800 lb.
SC603314	48 x 24 x 72	90 Pegboard Hooks	700 lb.
SC336375P		Padlock with 2 Keys	

GLOBAL® CYLINDER STORAGE CABINET

Ruggedly Built Cabinets Are Used For Protecting LPG Cylinders From Theft & Unauthorized Access

Cylinder Storage Cabinets are made of solid 14 gauge steel top and bottom for strength. Features 1/8"x13/16" expanded metal door(s) and sides which allow for ventilation and visibility of contents. Rust and acid resistant safety yellow powder coat finish for long lasting durability. Padlock hasp keeps contents secure for safely storing compressed air/gas cylinders and tanks, (padlock not included). Cabinet will accept 20 lb and 33 lb LPG cylinders. "DANGER FLAMMABLE MATERIALS" sign is located on the door(s). Door stoppers have magnets to keep doors safety shut when not locked. Pre-punched lagging holes in feet for anchoring to the ground. Complies with OSHA regulations.

Cylinder Capacity	Style	W"x D" x H"	Unassembled Model	Assembled Model
4	Horizontal	31 x 30 x 35	SC270252	SC493352
8	Horizontal	31 x 30 x 65	SC270253	SC493353
16	Horizontal	60 x 30 x 65	SC270254	SC493354
9	Vertical	31 x 30 x 65	SC270256	SC493356
18	Vertical	60 x 30 x 65	SC270255	SC493355
8 Horizontal/9 Vertical	Horizontal & Vertical	60 x 30 x 65	SC270257	SC493357



WALL MOUNT CYLINDER BRACKETS



Easily mounts to permanent vertical surface to help you safely store gas cylinders. Supports cylinders from 3 1/2" to 12 1/2" in diameter. Reinforced red polyethylene Plastic Bracket is ideal for highly corrosive environments. Durable welded Steel Bracket has protective vinyl edge with enamel finish. All styles include 1 1/2" polypropylene strap with steel cinch buckle. Mounting hardware not included. Complies with OSHA and NFPA standards.

Model	Cylinder Capacity	Material
SC116036	One	Plastic
SC116037	One	Steel
SC116038	Two	Steel
SC116039	Three	Steel

FORKLIFTABLE CYLINDER CADDY

Made of heavy duty steel for long lasting durability. Features a forkliftable design allowing for easy storage and transport. Holds cylinders up to 9" in diameter. 1500 lb. load capacity. Hinged retainer bars secure cylinders in place during handling. Designed for convenient loading and unloading. Cylinders roll on or off at floor level without lifting or rolling up a ramp. For use with fork width up to 6". Dissipative ground chain included for security.



Model	Style	Cyl. Cap.	Depth"
SC270217	Stationary	4	23
SC270218	Stationary	6	33
SC270219	Stationary	8	43
SC270217C	Mobile	4	23
SC270218C	Mobile	6	33
SC270219C	Mobile	8	43

GLOBAL® FLAMMABLE CABINETS



GLOBAL
HEAVIER DUTY
14 GAUGE DOORS &
4" HINGE



GLOBAL
FLUSH PADDLE
HANDLE



GLOBAL SC237286
MANUAL CLOSE DOUBLE DOOR

Specifications	GLOBAL
Wall Gauge	18
Door Gauge	14
Corners	Safety Radius
Adj. Shelf Increments	2 1/2
Handle Type	Recessed
Hinge Type	HD 4"
Finish	Powder Coat
Code Approval	NFPA, OSHA, FM
Limited Warranty	12 Year
Shelves	Galvanized Steel

Gal. Cap.	Adj. Shelves	W" x D" x H"
MANUAL CLOSE DOOR		
22	1	34 x 18 x 35
28	2	34 x 18 x 44
30	1	43 x 18 x 44
44	3	34 x 18 x 65
45	2	43 x 18 x 65
60	2	31 1/4 x 31 1/4 x 65
60	2	34 x 34 x 65
90	2	43 x 34 x 65
120	2	59 x 34 x 65
BI-FOLD DOOR		
30	1	43 x 18 x 44
45	2	43 x 18 x 65
60	2	34 x 34 x 65
90	2	43 x 34 x 65
SELF-CLOSE DOOR		
22	1	34 x 18 x 35
28	2	34 x 18 x 44
30	1	43 x 18 x 44
44	3	34 x 18 x 65
45	2	43 x 18 x 65
60	2	31 1/4 x 31 1/4 x 65
60	2	34 x 34 x 65
90	2	43 x 34 x 65

Model	Lbs.
SC237774	170
SC237775	220
*SC116053	240
SC237776	290
SC237286	330
---	---
SC237289	380
SC237292	450
SC237777	540
MANUAL CLOSE	
SC237284	260
SC237287	350
SC237290	400
SC237293	460
---	---
SC237778	190
SC237779	240
SC237285	260
SC237780	310
SC237288	350
---	---
SC237291	400
SC237294	460



FUSIBLE LINK
Fusible link holds doors wide open and melts at 165°F to automatically close (on self-close models).

- THREE DOOR STYLES:**
- 1. MANUAL CLOSE DOORS** will not close automatically
 - 2. SELF CLOSE DOORS** automatically close only when fusible link melts at 165°F
 - 3. SELF CLOSE BI-FOLD DOORS** close automatically during normal use and at 165°F



Additional Shelves	
W" x D"	Global
34 x 18	SC237792
43 x 18	SC237295
34 x 34	SC237297
43 x 34	SC237298
59 x 34	SC237793

*Chrome lever handle and piano hinge

GLOBAL® FLAMMABLE CABINETS

COMPACT FLAMMABLE CABINETS are perfect where space is limited. Meet or exceed all NFPA and OSHA requirements. Constructed of 18-gauge steel. **MANUAL-CLOSE** door must be physically closed. **SELF-CLOSE** door closes in the event of fire via a fusible link that melts at 165°F and releases the closing mechanism (per Uniform Fire Code). Full-length piano hinges and 3-point locking handle for smooth door operation. Yellow **powder coat** finish accompanied by a large red warning label "FLAMMABLE - KEEP FIRE AWAY".

Gal. Cap.	Adj. Shelves	W" x D" x H"	GLOBAL MANUAL CLOSE Model
2	1	15 x 18 x 17 1/4*	---
4	1	17 x 17 x 22*	---
4	1	17 1/2 x 18 x 22 1/2*	---
12	1	23 x 18 x 35*	SC962355
16	1	23 x 18 x 44*	SC962356
20	5	43 x 12 x 43†	---
22	1	35 x 22 x 35	SC962357
24	3	43 x 12 x 44†	SC962358



Compact Wall Hung or Bench Mountable

TOUGH POWDER COAT FINISH



SC962357

† Wall Mount Cabinet *Single Door

01-800-467-0529

chproductos.com

53

GLOBAL PAINT & INK/ACID CORROSIVE/PESTICIDE CABINETS



SC237695



GLOBAL
4" HINGE



GLOBAL
FLUSH PADDLE
HANDLE

GLOBAL Cabinets are constructed of all welded, double walled 18 gauge steel with 1 1/2" air space and dual 2" capped vents with flame arrestors. Doors are double walled with 14 gauge outside and 18 gauge inside. All models have heavy-duty 4" welded hinges with brass pins and 3-point locking doors for added security. Features flush mounted, grip padded handle. Galvanized steel shelves have 350 lb. capacity and adjust on 2 1/2" centers. Ground connection dissipates static charge. Includes 2" leak proof door-sills and adjustable leveling feet. Meets FSPA code 30, OSHA standards and FM approved. **Paint & Ink** models have a red powder coat finish. **Acid Corrosive** models have a blue powder coat finish. **Pesticide** models have a green powder coat finish. Both Acid and Pesticide models include corrosive resistant polyethylene trays.

**12 Year
Limited
Warranty!**

STEEL CABINETS FEATURE THREE DOOR STYLES:

- 1. MANUAL-CLOSE DOORS**
will not close automatically
- 2. SELF-CLOSE DOORS**
automatically close only when fusible link melts at 165°F
- 3. SELF-CLOSE BI-FOLD DOORS**
close automatically during normal use and at 165°F



Gal. Cap.	Adj. Shelves	W" x D" x H"	MANUAL CLOSE DOOR Model	MANUAL CLOSE BI-FOLD DOOR Model	SELF CLOSE DOOR Model	ADDITIONAL SHELVES Model
PAINT & INK						
18	2	23 x 18 x 35	SC237691	---	SC237697	SC237706
24	3	23 x 18 x 44	SC237692	---	SC237698	SC237706
36	5	23 x 18 x 65	SC237693	---	SC237699	SC237706
48	3	43 x 18 x 44	SC237694	SC237703	SC237700	SC237707
72	5	43 x 18 x 65	SC237695	SC237704	SC237701	SC237707
96	5	34 x 34 x 65	SC237696	SC237705	SC237702	SC237708
ACID CORROSIVE						
12	1	23 x 18 x 35	SC240469	---	SC240473	SC240478
18	1	23 x 18 x 44	SC240470	---	SC240474	SC240478
24	1	23 x 18 x 65	SC240471	---	SC240475	SC240478
30	1	43 x 18 x 44	SC237709	SC237713	SC237711	SC237715
45	2	43 x 18 x 65	SC237710	SC237714	SC237712	SC237715
60	2	34 x 34 x 65	SC240472	SC240477	SC240476	SC240479
PESTICIDE						
12	1	23 x 18 x 35	SC240480	---	SC240486	SC240495
18	1	23 x 18 x 44	SC240481	---	SC240487	SC240495
24	1	23 x 18 x 65	SC240482	---	SC240488	SC240495
30	1	43 x 18 x 44	SC240483	SC240492	SC240489	SC240496
45	2	43 x 18 x 65	SC240484	SC240493	SC240490	SC240496
60	2	34 x 34 x 65	SC240485	SC240494	SC240491	SC240497



SC237606

Gal. Cap.	Adj. Shelves	W" x D" x H"	GLOBAL Model
MANUAL CLOSE DOOR			
6	0	23 x 18 x 22	SC240899
12	1	23 x 18 x 35	SC237582
18	2	23 x 18 x 44	SC237584
22	3	23 x 18 x 65	SC237606
54	3	23 x 34 x 65	SC237766
SELF-CLOSE DOOR			
6	0	23 x 18 x 22	SC240900
12	1	23 x 18 x 35	SC237583
18	2	23 x 18 x 44	SC237585
22	3	23 x 18 x 65	SC237607
54	3	23 x 34 x 65	SC237769
ADDITIONAL SHELVES			
		W" x D"	GLOBAL Model
		23 x 18	SC237608
		23 x 34	SC237794

12 year limited warranty

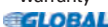

SLIM FLAMMABLE CABINETS

All welded double-walled 18 gauge steel construction with 1 1/2" insulating air space. 2" leak-proof door sills contain leaks and spills. Includes two 2" diameter flame arrestor vents, adjustable leveling feet, galvanized steel shelves and grounding connector. Meets OSHA and NFPA code 30 standards. FM approved (Not



SC240899

Including 6 Gallon). Powder coat finish. **Global cabinets** feature 14 gauge outside wall construction, lockable flush paddle handle and 4" heavy-duty welded hinges with brass pins. **Justrite cabinets** include full length piano hinge doors and recessed pad-lockable handle. **Self-Close Door** models will close via a fusible link that melts at 165° releasing the closing mechanism.

SCISSOR LIFT TABLE

Simple Foot Pedal Operation

Simply the Best Value Available...

Convenient and compact. Low effort foot action pump. Smooth rolling 5" casters, two with brakes. Automatic increasing speed control; unique hydraulic pump is designed to descend slower with increased weight. Welded steel frame with durable powder coat finish. Includes handy hook-on bin to carry parts. 2 Year Limited Warranty.



SC954850

Model	Cap. Lbs.	Table L" x W"	Height		Strokes To Max.
			Min.	Max.	
SC954850	660	29 1/2 x 19 3/4	10 3/4	31 1/2	16
SC954852	1100	35 1/2 x 23 1/2	11 3/4	36 1/2	25

WORK POSITIONING LIFT TABLE

Foot Control or Battery Operated!

Bring the work to the worker! Use at conveyor or production lines, as an adjustable workbench or positioning table, or at the dock loading/unloading trucks. Solid steel platform and base with durable enamel finish, and central lift point offer sure, stable lifting. Safety floor lock holds table in position. 1 Year limited warranty.

FOOT CONTROL has durable hydraulic jack offering 7/16" of lift per stroke (1/8" on 6000 lb. models). Easy rolling 2 swivel, 2 rigid polyurethane wheel casters.

Model	Style	Cap. Lbs.	L" x W"	Height"		Wheel Dia"
				Min.	Max.	
SC501098†	A	200	16 x 16	29	46	3
SC232054	B	500	18 x 18	30	48	4
SC232056	B	1000	36 x 18	30	48	4
SC241381	C	2000	36 x 24	30	48	4
SC241382	C	2000	48 x 32	30	48	4
SC232066	C	6000	36 x 24	37	59	6
SC232068	C	6000	48 x 32	37	59	6

†Four swivel casters, without floor lock.



GLOBAL PALLET POSITIONER

Helps to Reduce Worker Strain and Risk of Injury Injury from Lifting, Bending and Stretching.



SC988295

This ergonomic tool is ideal for building or unpacking pallet loads. A combination of heavy-duty springs and shock absorbing dampener maintain a constant working height without overshoot or spring bounce, lowering and raising the carousel as packages are removed or added. No power or air supply is required, and it is virtually maintenance free! The 43-5/8" diameter turntable features low-friction bearings for smooth operation. Full 360° access allows for nearside loading without reaching, as the operator can step closer to the unit's platform to add or remove pallet loads. Wide, free-standing base features 36-5/8" L x 6"W x 2"H fork pockets for easy relocation by fork lift. Strong tubular steel frame with durable powder-coat finish for long life. 1 Year Limited Warranty.

Model	Cap. Lbs.
SC988295	400 min./4500 max.

ELECTRIC PALLET TRUCK

Increase Worker Productivity, Efficiency and Safety!



SC988294

Fully powered electric pallet truck easily lifts and lowers loads with a push of a button. Maneuvers loads up ramps and inside trailers. Double reinforced welded forks for years of service. High-torque 24V DC drive and lift motors handle heavy-duty jobs. Ergonomic handle features easy to operate throttle with infinite forward and reverse speeds, lift/lower controls, safety belly reverse button, and horn. Includes a Curtis controller for smooth and responsive control, and an electromagnetic disc brake with automatic dead-man feature that activates when user releases handle. Includes battery, integral battery charger, Curtis battery level gauge and emergency battery disconnect. Rolls smoothly on polyurethane steer and load wheels. Features 0.7 KW drive and 0.8 KW lift motors, 3-5/16" lowered and 8" raised heights. Offers a minimum of 8 hours service per charge. 1 Year Limited Warranty.

Model	Cap. Lbs.	Fork W" x L'
SC988294	3300	24 13/16 x 47

BEST VALUE PALLET TRUCK

5500 lb. capacity

Over 1,000,000 Sold!



REINFORCED FRAME & SOLID STEEL TIE RODS



POLYURETHANE LOAD WHEELS

ENTRY ROLLERS



Durable and economical, this truck offers the best value for your material handling needs. Reinforced tapered steel forks. Spring loaded self-righting safety loop handle. Easy to operate 3-function hand control (raise, neutral, lower) for smooth control. Hardened chrome piston with protective dust cover. Durable powder coat finish.

GERMAN HYDRAULIC SEALS

FLOOR PROTECTIVE POLYURETHANE STEER WHEELS

Model	W" x L"
SC334475	27 x 48
SC251783	27 x 42
SC251784	21 x 48
SC251785	21 x 36
SC988184	27 x 60

PREMIUM PALLET TRUCK

A Real Warehouse Workhorse!
Proven 6600 lb. capacity

Sealed leak-proof **Exclusive Endura Pump** with hardened chrome piston and ram offers smooth, trouble-free operation. Steel roller chain mechanism opens and closes valve with precision. By-pass valve helps protect against overload. Super-strong, box flanged structurally reinforced tapered forks. Convenient 3-stage (raise, neutral, lower) fingertip control and safety loop handle. Includes grease fittings to help maintain performance. Articulated 3/4" axle allows load to move smoothly across uneven surfaces. Durable powder coat finish.



EXCLUSIVE ENDURA PUMP



STRUCTURALLY REINFORCED FORKS



Model	W" x L"
SC585354	27 x 48

SPECIALTY FORK SIZE MODELS - 6600 Lb. Capacity

Model	W" x L"	Model	W" x L"
SC168032	27 x 42	SC168034	21 x 48
SC168033	27 x 36	SC168035	21 x 42
		SC168036	21 x 36

LOW PROFILE MODELS - 4500 Lb. Capacity

Model	W" x L"	Model	W" x L"
SC168037	27 x 48	SC168039	21 x 48
SC168038	21 x 42	SC168040	21 x 36



ARTICULATED AXLE

SC585354

FLOOR PROTECTIVE POLYURETHANE WHEELS

QUICK REFERENCE PALLET TRUCK SPECIFICATIONS CHART

Model	Capacity Lbs.	Lowered Ht."	Raised Ht."	Fork Width"	Steer Arc°	Adjustable Tie Rod*	Steer Wheel	Load Wheel	Entry Rollers	Warranty	Limited
BEST VALUE	5500	3	7 ³ / ₄	6	190	No	7" Polyurethane	3" Polyurethane	Yes	1 Year	
PREMIUM	6600	3	7 ¹ / ₂	6 ¹ / ₄	200	Yes	7" Polyurethane	3" Polyurethane	Yes	5 Year	
PREMIUM (Low Profile)	4500	2 ¹ / ₈	6 ¹ / ₄	6 ¹ / ₄	200	Yes	7" Polyurethane	2" Solid Steel	No	5 Year	
ERGO	5500	3	7 ¹ / ₂	6 ¹ / ₄	190	Yes	7" Polyurethane	3" Polyurethane	Yes	2 Year	
QUICK-LIFT	5500	3	7 ¹ / ₂	6 ¹ / ₄	210	Yes	7" Polyurethane	3" Polyurethane	Yes	5 Year	
HIGH CAPACITY	11,000	3 ¹ / ₂	8	8 ¹ / ₄	210	Yes	8" Steel	3" Steel	No	2 Year	

* Helps to keep proper fork alignment.

GALVANIZED & STAINLESS STEEL PALLET TRUCKS

Perfect for Pharmaceutical & Food Service Industry



4400 lb. capacity



SC241629

Specifically designed for corrosive or extremely wet environments and ideal for use in laboratories and clean rooms. **Choice of Galvanized Frame or Premium 316 Stainless Steel Frame** truck for ultimate corrosion protection. **Exclusive Endura zinc-plated pump** with chrome-plated components offers reliable service. 27"W x 48"L with 6 1/4"W tapered forks that include entry rollers for smooth pallet entry/exit. Comfortable self-righting corrosion resistant galvanized or stainless steel handle has 3-function hand control (raise, neutral, lower) for smooth control. 210° turning radius, 3" lowered height and 7 1/2" raised height. 7" nylon steer wheels and 2 3/4" nylon load wheels. 1 Year Limited Warranty.

Model	Pallet Truck Type
SC241628	Galvanized
SC241629	Stainless Steel

ERGO PALLET TRUCK

The Next Generation of Pallet Truck!



EXCLUSIVE ENDURA PUMP

5500 lb. capacity

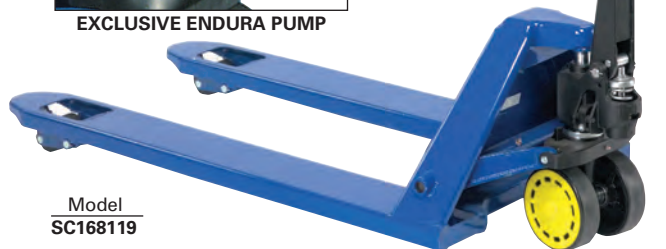

Model
SC168119

Offset, contoured handle helps alleviate stress and strain. Slip-resistant plastic grip minimizes vibration and reduces the transfer of cold and heat to the hands. Features a fully sealed **Exclusive Endura Pump** with controlled, variable speed lowering reducing product damage. Spring loaded finger grip automatically stops lowering when released to help reduce foot injury. Includes grease fittings to help maintain performance. Tapered 27" W x 48" L forks. Durable powder coat finish.

SEE QUICK REFERENCE CHART ON OPPOSITE PAGE FOR ALL TRUCK SPECIFICATIONS.

HIGH CAPACITY PALLET TRUCK

Lift & Move 11,000 lbs.!

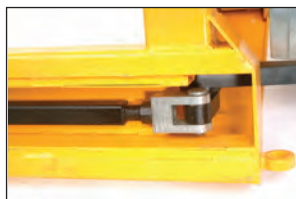

SOLID STEEL TIE-RODS, REINFORCED FRAME AND INTEGRAL TOW LOOP



TWIN STEEL LOAD ROLLERS



Model
SC241637

Rugged, double-channel reinforced structural steel frame handles loads up to 5 1/2 tons! Solid steel pump mount and extra heavy-duty pump with high-pressure seals and hardened chrome-plated piston for years of service. Adjustable solid steel tie rods maintain proper rollability of truck. Steel steer wheels and twin steel load rollers assure secure load movement in toughest environments. Frame includes integral tow loops. Safety loop handle has 3-function hand control (raise, neutral, lower). Tapered 23"W x 45 1/2"L forks. Durable powder coat finish.

SEE QUICK REFERENCE CHART ON OPPOSITE PAGE FOR ALL TRUCK SPECIFICATIONS.

QUICK-LIFT PALLET TRUCK



OFFSET ERGO HANDLE



5500 lb. capacity

Model
SC168081

The fastest, most productive truck on the market! Within 2 strokes, pallet is ready to be moved. Highly efficient; achieve maximum lift height in half the time. Pump automatically switches to normal operation when load exceeds 250 lbs. European designed fully sealed **Exclusive Endura Pump** has integral overload protection valve. Slip-resistant offset handle offers comfort and safety. Welded, high strength, 27"W x 48"L "C" section forks supply extra rigidity. Durable powder coat finish.

SEE QUICK REFERENCE CHART ON OPPOSITE PAGE FOR ALL TRUCK SPECIFICATIONS.

DUAL DIRECTION PALLET TRUCK

*Unique, Lateral Movement Pallet Truck
Moves Long Loads in Narrow Areas!*

Model
SC168041



**5000 lb.
capacity**

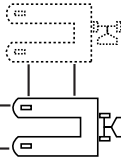

LATERAL MODE

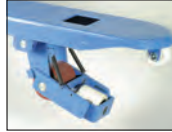

STANDARD MODE



This pallet truck combines the functionality of a standard truck with the versatility of a lateral moving truck. Perpendicular movement is achieved by raising the load to 7 1/4" high, which automatically activates the side rolling load wheels. Simply turn the steering handle, set the lock detent into place and truck moves loads up to **2200 lbs. in the lateral mode**. Ideal for maneuvering in tight areas, truck can also be used to move oversized items by placing load across the forks. Lateral mode offers 7 1/4" lowered height and 8 1/2" raised height. **Standard mode offers 5000 lb. capacity, 3 2/5" lowered height and 7" raised height.** Ergonomic rubber coated handle improves comfort and grip. 27"W x 48"L with fully adjustable fork connecting rods. 7"W forks. Built-in safety bypass valve prolongs jack life by preventing overloading. Durable powder coat finish. 1 Year Limited Warranty.

PALLET TRUCK CHOCK



Model
SC988025

The pallet jack stop is engineered to hold any pallet truck in place in a moving truck or trailer. Its unique design helps to reduce freight and trailer damage due to runaway pallet jacks, making it ideal for freight, logistics and trucking companies. Durable rubber skid jack stop prevents any movement on the floor of a truck or trailer, protecting valuable freight from damage caused when a pallet jack rolls or slides unsecured. The chock works on any surface and will not slip. Truck drivers simply pull the pallet jack into the stop and it is securely parked in seconds. Drivers will never again have to tie a pallet truck down or turn the pallet truck on its side. 14"L x 12"W x 2"H overall and weighs only 3.5 lbs.



BATTERY TRANSFER PLATFORM



PALLET TRUCK
NOT INCLUDED

**4000 lb.
capacity**

Convert your existing 27"W x 48"L pallet truck into a cost-effective portable battery changer. One person can load, unload and transfer forklift batteries. 2 1/4" diameter steel rollers and hand-crank winch with 6' cable and safety latch hook safely facilitate horizontal battery transfer. Because the pallet truck's height is adjustable, it aligns easily with forklift's battery compartment; height to top of rollers is 2 9/8" above pallet truck's forks. Front locking safety tabs secure battery to deck. All-welded steel construction with durable powder coat finish. 48"L x 33"W x 7"H overall (46"H to top of winch) with 40"L x 30"W usable deck.

Model **SC241957**

PALLET SCALE TRUCK



Model
SC242066



LCD DISPLAY SCALE

4400 lb. capacity



A quick and economical solution to determine pallet weights. Use at the dock to estimate incoming and outbound shipments or in the warehouse to avoid overloading pallet racks. Patented frame mounted sensor measures deflection caused by the load. Displays up to 4400 lb. capacity in 10 lb. increments and accurate to +/- 40 lbs. throughout lifting capacity range. LCD display with 3/4"H characters offers ZERO, TARE and LB/KG keypads. Scale operates on (4) AA batteries (included) with automatic shut-off after 3 minutes. 6.3"W tapered forks are 27"W x 48"L. 3-position hand control. 7" polyurethane steer wheels, 2 3/4" load wheels, 210° steer arc, 2.95" lowered ht., 7.7" raised ht. 1 Year Limited Warranty.

LOW PROFILE PALLET SCALE TRUCK

Weigh & Move Loads in Seconds

Quickly verify inbound and outbound freight. Versatile truck combines all features of a pallet truck with a portable Mettler-Toledo HAWK scale/sensor. (242050 has Ravas scale/sensor). UL approved scale operates on C-cell batteries (included) or 7' AC power cord (included). Model **SC241414** has an integrated RS-232 port for sending data to serial device. Back-lit LCD display with 1"H characters. 4 color-coded, tactile-feel keys (ZERO, TARE, FUNCTION, PRINT). Displays up to 5000 lb. capacity in 1 lb. increments (or kilograms/grams). Accurate to 0.15%. 7"W tapered forks are 27"W x 48"L. 3 position hand control. 7" polyurethane steer wheels, 2 1/2" load wheels, 210° steer arc. 2.95" lowered height, 7 3/4" raised height. Durable powder coat finish. **NTEP Approved Legal for Trade Class III Truck** is certified for commercial transactions and is supplied with certificate of compliance. 1 Year Limited Warranty.

Model
SC241414
SC242050

Description
Pallet Scale Truck
NTEP Legal for Trade Pallet Scale Truck



**5000 lb.
capacity**



LCD DISPLAY SCALE



HI-LIFT SKID TRUCK *Raises Load to a Comfortable Work Height*



**BATTERY OPERATED
2200 LB. CAP.
SC241718**

**2200 lb.
capacity**



SC241717



**BATTERY OPERATED
3300 LB. CAP.
SC241719**

**2200 lb.
capacity**



SC983222

Perfect for loading/unloading operations. **Includes Free Slip-On Platform to allow unit to be used as a Lift Table.** Continuous welded heavy steel frame handles heaviest loads. Heavy duty double roller chain with 2:1 ratio for fast lifting. 6"W forks can be raised from 3 1/2" to 33 1/2" H. **Manual foot operated pedal model** requires 75 strokes to full lift height at maximum capacity and is 65 1/2" L overall. **Battery operated model** has 12V/90AH battery and 12 amp charger offering 15 second lift time to max. ht. and is 70" L overall. Comfortable handle allows easy steering. Rolls easily on 6" polyurethane steer wheels with locking brakes and 2 3/4" load rollers. **Use with single faced pallets, skids and bulk containers. 2 Year Limited Warranty.**

Heavy duty truck has 4mm thick reinforced steel plate for added strength. Forks can be raised from 3 1/2" to 31 1/2" H. Support legs automatically extend when the load reaches 16 1/2" H and help prevent the truck from moving. **2200 lb. capacity manual pump handle model** requires 60 strokes to reach full height at maximum capacity and automatically slows the descending speed with heavier loads to help protect cargo. **3300 lb. capacity battery operated model** has 12V/63AH battery and 10 amp charger offering 15 second lift time to max. ht. Rolls easily on 7" polyurethane steer wheels and 3" load rollers. **Use with single faced pallets, skids and bulk containers. 2 Year Limited Warranty.**

Model	Fork Size
MANUAL FOOT PEDAL – 2200 LB. CAP.	
SC241716	20 1/2" W x 44 1/2" L
SC241717	27" W x 44 1/2" L
BATTERY OPERATED – 2200 LB. CAP.	
SC241718	27" W x 44 1/2" L

Model	Fork Size
MANUAL PUMP HANDLE – 2200 LB. CAP.	
SC983222	27" W x 45" L
BATTERY OPERATED – 3300 LB. CAP.	
SC241719	27" W x 44" L

PANEL AND LUMBER TRUCK *Complete with Uprights Included* **60" L x 30" W Deck 2400 lb. capacity**

Transport plywood, drywall, lumber, pipe and other long, bulky products with ease. Removable 1 3/16" dia. steel pipe uprights are 24" and 34" high and offer (2) 7"W and (1) 10"W bays to help keep the oversized cargo stable. Strong 60" L x 30" W 14 gauge channel reinforced steel deck with welded upright sockets for maximum durability. Rolls easily on 2 swivel, 2 rigid casters. 6" wheels offer 9 1/2" deck height while 8" wheels offer 11 1/2" height. Scratch resistant enamel finish. Assembles easily. **Optional 1/2" thick Carpeted Plywood Deck** helps protect cargo, offers quieter transport. **Specify Carpeted Deck suffix (C) to model.**

2000 LB. CAP MOLD-ON RUBBER 6" x 2" WHEELS	2400 LB. CAP MOLD-ON RUBBER 8" x 2" WHEELS	1200 LB. CAP FULL PNEUMATIC 8" x 2 1/2" WHEELS
Model	Model	Model
SC241443	SC241444	SC241445



**SC241444C
OPTIONAL
CARPETED DECK**



SC241444

ADJUSTABLE PANEL TRUCK *Expandable Frame Capacity to Suit Your Needs!*

Upright 1 3/16" dia. pipe frames are available in three different heights to allow easy access of cargo, while keeping materials upright. Uprights adjust on 3 1/2" increments. **(Upright frames sold separately.)** 24"W truck has 7 available socket positions while the 30"W truck has 9 sockets. Truck platform is constructed of 1 1/2" x 1/2" thick angle iron frame with rounded safety edges finished in scratch resistant blue enamel. Rugged 3/4" thick plywood deck has a durable lacquer finish. Rolls smoothly on 2 swivel, 2 rigid casters. Choice of high-capacity mold-on rubber or non-marring "cushion-ride" pneumatic wheels. Assembles easily.

PANEL TRUCK- (Purchase Uprights Separately)			
L" x W"	2000 LB. CAP MOLD-ON RUBBER 6" x 2" WHEELS	2400 LB. CAP MOLD-ON RUBBER 8" x 2" WHEELS	1200 LB. CAP FULL PNEUMATIC 8" x 2 1/2" WHEELS
	Model	Model	Model
48 x 24	SC241543	SC585228	SC585229
60 x 30	SC241544	SC585231	SC585232
UPRIGHT FRAMES- (Sold In Pairs)			
H" x L"	Model	H" x L"	Model
12 x 48	SC585233	12 x 60	SC585236
26 x 48	SC585234	26 x 60	SC585237
38 x 48	SC585235	38 x 60	SC585238

**2400 lb.
capacity**



STEEL DECK TRUCK

All Welded Construction

All welded heavy duty 14 gauge steel decks, reinforced with internal longitudinal stiffening members for extra strength. **Non-marring integral corner bumpers protect walls.** Removable pipe handle. Bolt-on casters are double ball race, two swivel and two rigid. Durable baked gray enamel finish. 5" dia. wheels offer 7 1/2" deck height, 6" dia. have 8 1/2" height and 8" dia. have 10 3/4" height. **Optional Ergo Handle helps to reduce strain on the back, wrists and arms. Specify Ergo suffix (E) to any model.**

Deck L" x W"	Model
5" x 1 1/4" POLYURETHANE WHEELS	
1000 LB. CAP.	
36 x 24	SC952105
48 x 24	SC952106
48 x 30	SC952107
60 x 30	SC952108
72 x 36	SC952109
5" x 1 1/2" RUBBER TIRED WHEELS	
1400 LB. CAP.	
36 x 24	SC952110
48 x 24	SC952112
48 x 30	SC952113
60 x 30	SC952116
72 x 36	SC952118
6" x 2" RUBBER TIRED WHEELS	
2000 LB. CAP.	
36 x 24	SC952121
48 x 24	SC952123
48 x 30	SC952122
60 x 30	SC952127
72 x 36	SC952129
8" x 2" RUBBER TIRED WHEELS	
2400 LB. CAP.	
36 x 24	SC952130
48 x 24	SC952132
48 x 30	SC952139
60 x 30	SC952136
72 x 36	SC952138
8" x 2 1/2" FULL PNEUMATIC SHOCK-ABSORBING WHEELS	
1200 LB. CAP.	
36 x 24	SC952110P
48 x 24	SC952112P
48 x 30	SC952113P
60 x 30	SC952116P
72 x 36	SC952118P



DOCUMENT HOLDER
SC489070Y

2400 lb. capacity



SHOCK-ABSORBING
PNEUMATIC
WHEELS

PROTECTIVE
BUMPERS

SC952112P

EXCLUSIVE BETTER BUILT
CHANNEL REINFORCED DECK



OPTIONAL ERGO HANDLE



SC241536

1200 lb. capacity

STAINLESS STEEL DECK TRUCK

All welded stainless steel truck is perfect for use in corrosive applications at labs, restaurants and hospitals. Premium 16 gauge #4 polished deck and 14 gauge caster mounts for years of service. Rolls smoothly on 2 swivel, 2 rigid casters. 5" wheels offer 8" deck height while 8" wheels have 12" height. Comfortable removable stainless steel push handle.

Deck L" x W"	Model	5" x 1 1/4" POLYURETHANE WHEELS 1200 LB. CAP.	8" x 3" FULL PNEUMATIC WHEELS 1200 LB. CAP.
36 x 18	SC241535		SC241539*
36 x 24	SC241536		SC241540
48 x 24	SC241537		SC241541
60 x 30	SC241538		SC241542

*Semi-Pneumatic Wheels

ALUMINUM DECK TRUCK

Lightweight, Maintenance Free - 2400 lb. capacity

Maximum strength, lightweight deck makes this the perfect choice for moving bulk product. All-welded aluminum channel frame and deck ensures long life and resists corrosion. Slip-resistant diamond tread deck surface has more grip cleats per square foot than competitive trucks, helping to prevent items from falling during transport. **Non-marring integral corner bumpers protect walls.** Newly designed offset ergonomic aluminum push handle helps reduce fatigue and increases maneuverability. Reinforced corner sockets on both ends allows use of additional push handle (sold separately). Rolls smoothly on 2 swivel, 2 rigid roller bearing wheels. 5" dia. wheels offer 7 1/2" deck height, 6" dia. have 8 1/2" height and 8" dia. have 10 3/4" height.



SC241553

ALUMINUM HANDLE



NON-SLIP
DIAMOND TREAD

Deck L" x W"	Model	5" x 1 1/4" POLYURETHANE WHEELS 1000 LB. CAP.	5" x 1 1/2" RUBBER TIRED WHEELS 1400 LB. CAP.	6" x 2" RUBBER TIRED WHEELS 2000 LB. CAP.	8" x 2" RUBBER TIRED WHEELS 2400 LB. CAP.	8" x 2 1/2" FULL PNEUMATIC WHEELS 1200 LB. CAP.
48 x 24	SC241549	SC241549	SC241550	SC241551	SC241552	SC241553
48 x 30	SC232596	SC232596	SC232600	SC232610	SC232620	SC232630
60 x 30	SC232597	SC232597	SC232602	SC232612	SC232622	SC232631
56 x 42	SC241590	SC241590	SC241591	SC241592	SC241593	SC241594



SC241593

56" L x 42" W
Pallet Sized!



ADDITIONAL REMOVABLE
ALUMINUM HANDLE

Model	Deck Width"
SC241554	24
SC241555	30
SC241595	42

FREE
PROTECTIVE
BUMPERS

STEEL BOUND WOOD PLATFORM TRUCK

Deck L" x W"	5" x 1 1/4" POLYURETHANE WHEELS 1000 LB. CAP. Model	5" x 1 1/2" RUBBER TIRED WHEELS 1400 LB. CAP. Model	6" x 2" RUBBER TIRED WHEELS 2000 LB. CAP. Model
48 x 24 60 x 30	SC241706 SC241707	SC241708 SC241709	SC241710 SC241711
Deck L" x W"	8" x 2" RUBBER TIRED WHEELS 2400 LB. CAP. Model	8" x 2 1/2" PNEUMATIC WHEELS 1200 LB. CAP. Model	
48 x 24 60 x 30	SC241712 SC241713	SC241714 SC241715	

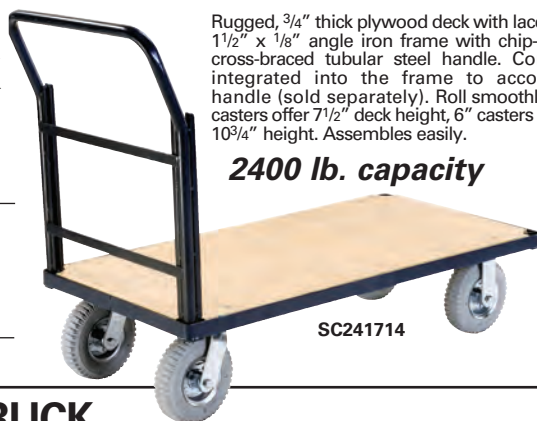

2400 lb. capacity

SC241714

Additional Removable Handle Model	Deck W"
SC241735	24
SC241736	30

**OPTIONAL
DOCUMENT
HOLDER
SC489070S**

HARDWOOD PLATFORM TRUCK

Superior performance at affordable prices. Flush 7/8" thick, kiln-dried and sealed deck reinforced with cross-battens for long life. Removable cross-braced tubular steel handle. **Stake Handle** models come complete with four 30"H removable pipe stakes. Roll smoothly on 2 swivel, 2 rigid casters. 5" dia. casters offer 7 1/2" deck height, 6" casters offer 8 1/2" height and 8" casters offer 10 3/4" height. Assembles easily.

Deck L" x W"	5" x 1 1/4" POLYURETHANE WHEELS 1000 LB. CAP. Model	5" x 1 1/2" RUBBER TIRED WHEELS 1400 LB. CAP. Model	6" x 2" RUBBER TIRED WHEELS 2000 LB. CAP. Model	8" x 2" RUBBER TIRED WHEELS 2400 LB. CAP. Model	8" x 2 1/2" PNEUMATIC WHEELS 1200 LB. CAP. Model
HARDWOOD DECK TRUCK					
48 x 24	SC952509	SC952500	SC952516	SC952501	SC952500P
54 x 27	SC952511	SC952503	SC952517	SC952502	SC952502P
60 x 30	SC952513	SC952505	SC952518	SC952504	SC952504P
72 x 36	SC241697	SC952507	SC952519	SC952506	SC952506P
STAKE HANDLE TRUCK					
48 x 24	SC241698	SC952508	SC241702	SC952523	SC952524
54 x 27	SC241699	SC952520	SC241703	SC952510	SC952525
60 x 30	SC241700	SC952521	SC241704	SC952512	SC952526
72 x 36	SC241701	SC952522	SC241705	SC952514	SC952527

**SC952500P
HARDWOOD DECK
TRUCK**

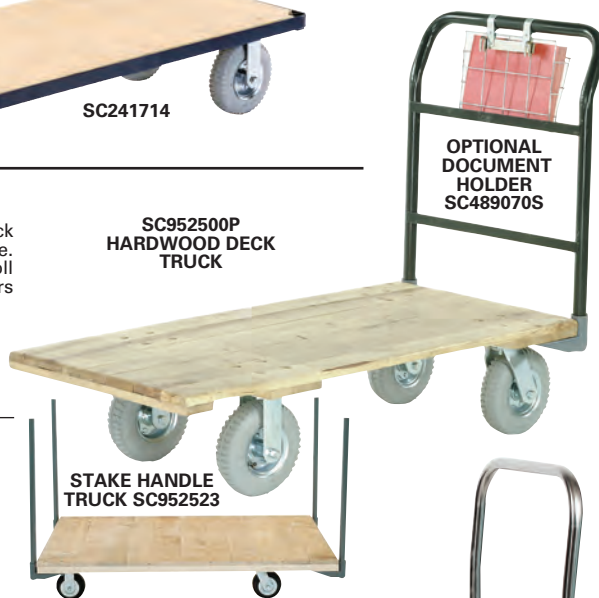

**STAKE HANDLE
TRUCK SC952523**

FOLDING PLATFORM TRUCK *Handles fold For Storage and Transport*

A wide variety of material handling trucks for route distributors, salespeople and warehousing. Comfortable, ergonomically designed handle folds down for compact storage. Integral vinyl deck bumpers protect doorways and walls. Lightweight, quiet rolling and maneuver easily on 2 swivel, 2 rigid rubber casters. Model SC241580 has dual folding handles for bi-directional use, plus a 5th wheel center mounted caster for additional deck rigidity.



**SC168134
STEEL DECK**



**SC109100
TELESCOPING ALUMINUM DECK**



**SC241419
ALUMINUM DECK
FOLDED POSITION**

**800 lb.
capacity**



**SC242092
STAINLESS
STEEL DECK**



**SC241580
ALUMINUM
DECK**

Model	Style	Platform L" x W"	Cap. Lbs.	Wheel Dia."	Wt. Lbs.
SOLID STEEL DECK with Non-Skid Vinyl Surface, Bungee Cord and Deck Hooks to help retain cargo.					
SC241373	F	28 x 18	400	4	25
SC241374	F	35 x 23	600	5	41
SOLID STEEL DECK with Non-Skid Vinyl Surface, Bungee Cord and Deck Hooks to help retain cargo, and Shock Absorbing, Non-Marring Pneumatic Wheels.					
SC168134	F	35 x 23	600	8	43
TELESCOPING ALUMINUM DECK extends from 20" to 28" long.					
SC109100	G	28 x 16	300	4	19

Model	Style	Platform L" x W"	Cap. Lbs.	Wheel Dia."	Wt. Lbs.
LIGHTWEIGHT ALUMINUM DECK with Skid-Resistant Ribbed Surface.					
SC241419	H	29 x 19	400	4	20
SC241578	H	36 x 24	600	5	35
SC241579	H	48 x 24	600	5	40
ALUMINUM DUAL HANDLE TRUCK has 5 casters for greater deck strength and capacity.					
SC241580	I	60 x 30	800	5	60
STAINLESS STEEL DECK offers maximum corrosion resistance.					
SC242092	H	29 x 19	440	4	26
SC242093	H	34 x 22 1/2	770	5	37



BEST VALUE!

EUROPEAN STYLE PLASTIC PLATFORM TRUCK

Rugged injection molded polypropylene platform is corrosion resistant and easily cleaned. Underside of platform is ribbed for extra strength to help absorb impact. Offset epoxy coated handle and 2 swivel and 2 rigid casters help to ease transport of materials. Models **SC241420** and **SC241421** offer a folding handle for compact storage. Models **SC252812** and **SC252814** offer sockets on each platform end to add an additional handle.

Up to 2000 lb. capacity

Model	L" x W"	Cap. Lbs.	Caster Dia."	Caster Type	Deck Ht."	ADDITIONAL HANDLE Model
SC241420	33 x 21	500	4	Polyurethane	6 1/2	---
SC241421	37 x 25	500	5	Polyurethane	8	---
SC252812	36 x 24	1000	5	Mold-On Rubber	8 1/2	SC252813
SC252814	52 x 25	2000	6	Mold-On Rubber	9 1/2	SC252815



NARROW AISLE PLATFORM TRUCK

Choose Wood, Steel or Aluminum Deck!

Handles more merchandise than several hand trucks and stock carts combined. Narrow deck width design simplifies movement in confined spaces, aisles or hallways. Six-wheel caster configuration allows truck to turn on its own radius. Twin removable handles allow transport of oversized cargo. **Choose steel bound 5/8" Plywood Deck with polyurethane finish, or 13 gauge Steel Deck with slip-proof diamond tread surface, both with 1500 lb. capacity** for maximum strength in toughest applications; two rigid 8" polyurethane wheels and four swivel 4" rubber casters with a 12" deck height. Durable powder coat finish. **Aluminum Deck truck** offers aluminum handles and slip resistant diamond tread 6063 T5 aluminum surface riveted to an all-welded aluminum deck. Corrosion resistant and lightweight truck has **1200 lb. capacity** and 9 1/2" deck height, and rolls easily on two 6" rigid and four 5" swivel polyurethane casters. **Optional Shelves** offer additional shelf space, as each truck can accommodate two shelves (350 lb. capacity per shelf).

1500 lb. capacity

SC330038
WOOD DECK TRUCK

SC242045
ALUMINUM DECK TRUCK

L" x W" x H"	STEEL DECK Model	WOOD DECK Model	ADDITIONAL STEEL SHELF Model
60 x 16 x 63	SC330034	SC168002	SC241690
60 x 24 x 63	SC330036	SC330038	SC241691

L" x W" x H"	ALUMINUM DECK Model	ADDITIONAL ALUMINUM SHELF Model
63 x 16 x 61	SC242045	SC242046



WOOD DECK PLATFORM TRUCK

2400 lb. capacity

Transport items safely. 51"L x 23 1/2"W truck has 1/2" varnished plywood deck with welded steel frame to handle heavy loads. Complete with twin removable 1" dia. tubular steel handles with cross-braces to help retain cargo. Rolls smoothly on 2 swivel, 2 rigid roller bearing wheels. Chip-resistant powder coat finish. Assembles easily.

Model	Wheel Type	Cap. Lbs.	Deck Ht."
SC241682	6" x 2" Mold-on Rubber	2000	8 1/2
SC241683	8" x 2" Mold-on Rubber	2400	10 3/4
SC241684	8" x 2 1/2" Full Pneumatic	1200	10 3/4

DEPOT PLATFORM TRUCK

All-Weather Open Grated Steel Deck!

Rugged steel construction assures years of performance. Ideal for transporting building materials, as well as wet or dirty loads, as water and debris flow through the deck. Strong 2" x 1" tubular steel frame with 1/8" thick steel grates welded to steel understructure for additional support. 1 1/4" cross-braced pipe handle. Durable powder coat finish. Rolls smoothly on 6" x 2" mold-on rubber casters; **4 Wheel Truck** has 2 swivel and 2 rigid casters and 10" deck ht.; **6 Wheel Truck** has 11" deck ht., two 8" rigid center casters and 4 swivel end casters that allow truck to turn on its own radius. Assembles easily.



OPEN GRATED DECK

SC241871
6 WHEEL TRUCK



60" L x 30" W
3200 lb.
capacity



Model	Description	Cap. Lbs.
SC241870	4 Wheel Truck	2000
SC241871	6 Wheel Truck	3200

HEAVY-DUTY STEEL 2-IN-1 HAND TRUCK

Versatile truck converts in seconds from a 55"H hand truck to a convenient platform truck. Heavy duty 3/4" dia. structural steel pipe frame with 14 gauge steel platform. Large 14" x 8" beveled nose-plate has integral wheel guards to help protect merchandise. Platform position offers 43"L x 14"W bed, 42"H handle, 3" rubber swivel casters and 600 lb. capacity. 10" rubber tired ball bearing wheels. Durable enamel finish. Shipped assembled.



SC185546



SC185545

600 lb.
capacity

Model	Wheel Type
SC185545	Semi-Pneumatic
SC185546	Full Pneumatic

3-IN-1 STEEL HAND TRUCK

600 lb. capacity

Easily converts to suit your needs! Features a 45° inclined position and can be used as a hand or platform truck. Heavy duty 14 gauge 1" dia. tubular steel construction for maximum durability. Includes folding 29" nose extension. 10" pneumatic wheels and 3 1/2" urethane swivel casters for smooth mobility. Durable powder coat finish. 51"H and 14"W. Shipped assembled.



HAND TRUCK POSITION WITH FOLDING NOSE RECESSED



INCLINE TRUCK POSITION WITH FOLDING NOSE EXTENDED



PLATFORM TRUCK POSITION

Model
SC983131

MULTI-FUNCTION 5-IN-1 TRUCK

Five Trucks for the Price of One!

Versatile truck converts easily for a multitude of uses and weighs just 41 lbs. Ideal for office use and folds compactly for storage and transport. 16 gauge welded tubular steel frame. Comfortable foam grip handle extends from 41" to 56"L. Rolls smoothly on 8" x 1 3/4" semi-pneumatic wheels and 2 1/2" rubber swivel casters. Hand truck position offers 300 lb. capacity and 14"W x 6 1/2"D reversible steel nose-plate. Platform and dolly position offer 400 lb. capacity. Instrument table position has 23 1/2" x 19" laminate top (25"H) with protective vinyl edge and 175 lb. capacity. Assembles easily.



HAND TRUCK



4-WHEEL HAND TRUCK



PLATFORM TRUCK



INSTRUMENT TRUCK

DOLLY

Up to 400 lb.
capacity

Model
SC241415

ALUMINUM 2-IN-1 HAND TRUCK

Converts in an instant from a standard hand truck to a useful platform truck. Convenient spring loaded auto-release bar offers simple conversion. High strength, lightweight aluminum frame and large beveled 18" x 7 1/2" aluminum nose-plate with integral wheel guards handles heaviest loads with ease. Anti-Slip grip handle provides safety and comfort. 10" x 3 1/2" full pneumatic wheels and 5" x 1 1/4" rubber swivel casters offer smooth rolling in any environment. 2 Year Limited Warranty. Assembles easily. **Optional Snap-On Decks** install easily to carry odd-shaped items in both truck positions; **Choice of Aluminum Deck** with non-skid tread-plate surface or **Carpeted Aluminum Deck** with durable slip-resistant all-weather carpet for a quiet ride.

ANTI-SLIP GRIP HANDLE

OPTIONAL SNAP-ON CARPETED DECK

800 lb. capacity

OPTIONAL SNAP-ON ALUMINUM DECK

Online Video & Photos

HAND TRUCK POSITION

ALUMINUM NOSE-PLATE

SENIOR JUNIOR

PLATFORM TRUCK POSITION

STYLE	JUNIOR	SENIOR
Hand Truck Ht."	52	62
Platform Truck Ht."	40	45
Platform Bed L"	43	56
Platform Bed W"	12	12
Hand Truck Cap. Lbs.	500	500
Platform Truck Cap. Lbs.	800	800
Weight Lbs.	42	48
Model	SC241664	SC241666
SNAP-ON DECKS	Model	Model
Aluminum	SC241665	SC241667
Carpeted Aluminum	SC241849	SC241850

Replacement Parts:	
Model	Description
SC241848	Set of (2) 5" Swivel Casters
SC168255A	Nose-plate
SC241677A	Set of (2) 10" pneumatic wheels and axle kit

ALUMINUM 3-IN-1 HAND TRUCK

Three trucks for the price of one! Converts in an instant from a standard two-wheel hand truck to either a 500 lb. capacity 45° incline truck or a four-wheel platform truck. High strength aluminum construction is strong yet lightweight. Huge cast aluminum 18" x 7 1/2" nose-plate accepts large loads and has integral wheel guards to protect cargo. Includes a convenient hide-away 27"L x 7 1/2" W folding nose extension to ease carrying of bulky Comfort grip anti-slip handle. Rolls smoothly on 10" full pneumatic tires and 5" x 1 1/4" rubber swivel casters. **Weights 42 lbs.!** Assembles easily. 2 Year Limited Warranty.

ANTI-SLIP FOAM HANDLE

HAND TRUCK POSITION

INCLINE TRUCK POSITION

FOLDING NOSE

PLATFORM TRUCK POSITION

Online Video & Photos

Replacement Parts:	
Model	Description
SC241848A	Set of (2) 5" Swivel Casters
SC168255B	Nose-plate
SC241677B	Set of (2) 10" pneumatic wheels and axle kit

Model	HAND TRUCK		PLATFORM TRUCK		
	Handle H"	Cap. Lbs.	Handle H"	Cap. Lbs.	Bed W" / Bed L"
SC241632	51 1/2	500	42	750	12 / 50

EASY LIFT DESK MOVER



Moves Wood or Steel Desks!

600 lb. capacity

Quickly move a double pedestal desk without removing contents or drawers. Positive safety latch automatically locks in the raised position. Heavy duty 2" rubber wheel swivel casters rotate 360° for easy maneuvering. Overall size - 22" x 32". Height 9³/₄" raised, 5¹/₂" lowered. Removable handle and tubular lift frame assembly is completely coated with non-marring material. Chip resistant blue finish.

Model
SC268602

FOLDING HAND CART

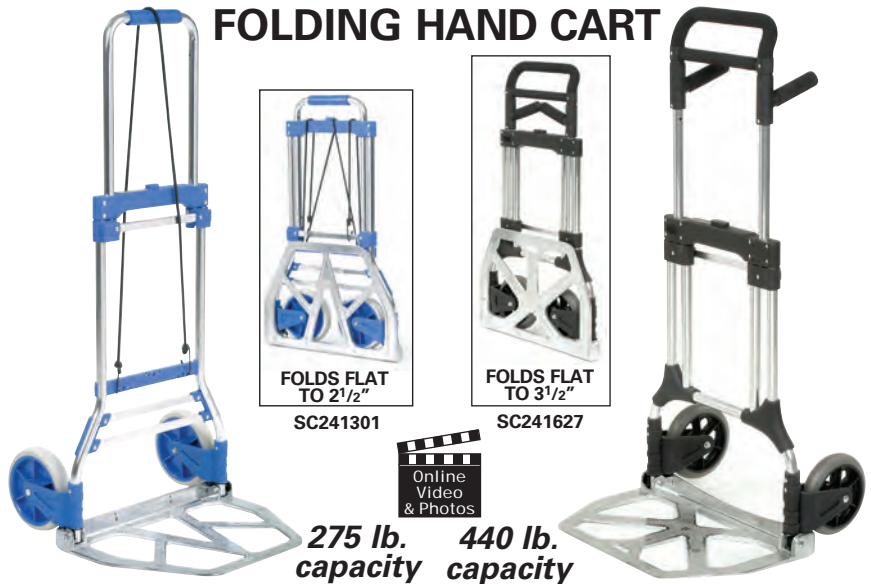

FOLDS FLAT TO 2¹/₂"
SC241301

FOLDS FLAT TO 3¹/₂"
SC241627



275 lb. capacity **440 lb. capacity**

Compact, collapsible carts fit neatly into overhead luggage compartments; perfect for airline travel. Strong tubular frame cart is lightweight, yet handles heavy loads. Comfort-grip telescopic handle and simple push button operation retracts wheels and folds nose-plate automatically in seconds. Durable cast aluminum nose-plate (150 lb. cart has a steel nose-plate) handles the load.

Model	Cap. Lbs.	Frame Type	Overall W" x D" x H"	Folded W" x D" x H"	Nose-plate W" x D"	Wheel Size	Wt. Lbs.
SC251847	150	Steel	16 x 16 ¹ / ₂ x 39	16 x 2 ¹ / ₂ x 28	15 x 11	5 x 1	9
SC251848	200	Steel	20 x 19 x 39	20 x 2 ¹ / ₂ x 29	19 x 11	7 x 1 ¹ / ₄	10 ¹ / ₂
SC241301	275	Aluminum	19 x 13 ¹ / ₂ x 42 ¹ / ₂	19 x 2 ¹ / ₂ x 31	19 x 13 ¹ / ₂	7 x 1 ¹ / ₄	10
SC241627	440	Aluminum	23 x 15 x 50	23 x 3 ¹ / ₂ x 40	23 x 15	8 x 1 ¹ / ₂	21

APPLIANCE TRUCKS

800 lb. capacity

Our popular Steel Appliance Truck has a rugged 7/8" tubular steel 59"H x 17¹/₂"W frame and 24" x 5¹/₂" steel nose-plate. Ratchet assembly with 14'L nylon belt securely holds load. Shipped assembled.

SC252605



POSITIVE RATCHET TIGHTENER



STAIR CLIMBER
Continuous rubber belt smoothly rotates on roller bearing, easing load up or down stair tread.

PROFESSIONAL APPLIANCE TRUCK

1200 lb. capacity

SC168067



SC168031

High-strength tubular steel frame with double-welded joints make this the professionals choice in appliance trucks. Smooth rolling continuous belt stair climbers. 2" x 14' nylon belt won't scratch load surface. Positive ratchet assembly assures secure load. Non-marring rubber on all contact surfaces. Easy rolling ball bearing wheels. 24" x 5" nose-plate. **2 wheel models** are 59"H x 17"W; **4 wheel model** offers unique handle which releases rear caster assembly from standing position. Gives you 4-wheel stability and 2-wheel maneuverability on 3¹/₂" rear casters and is 66"H x 17"W x 14¹/₂"D. Shipped assembled.

Model	Truck Type	Wheel Type	Wt. Lbs.	Cap. Lbs.
SC252605	Steel	8" Mold-on	51	800

Model	Style	Ht."	Wt. Lbs.	Cap. Lbs.	Wheel"
SC168067	2-wheel	59	62	750	8
SC168031	4-wheel	66	69	1200	8

01-800-467-0529

chproductos.com

65



FURNITURE DOLLY

Raise and Transport Bulky Items

3950 lb. capacity



Safely transport furniture, computer equipment or any odd-shaped item easily. Simple hand-operated hydraulic jack raises and lowers loads at controlled speeds. 23"W x 21/4"D lift plate raises load to 10"H. Positive ratchet mechanism with 16" nylon strap secures load. Rolls smoothly on 6" polyurethane casters. 26 1/2"L x 16"W x 42"H overall and weigh 95 lbs. each. Sold in pairs.

Model SC242044

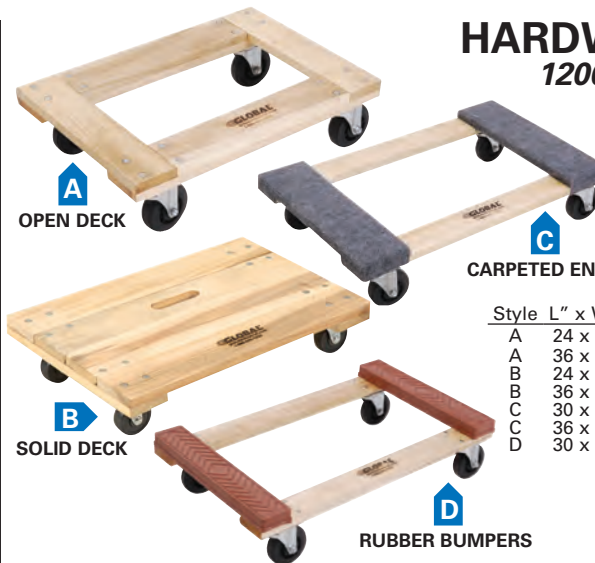

HARDWOOD DOLLY

1200 lb. capacity

Seasoned and sealed hardwood, smoothly finished with flush top bolted construction. Four swivel hard rubber casters.

CARPETED ENDS

Style	L" x W"	3" CASTER-	4" CASTER-
		1000 LB. CAP.	1200 LB. CAP.
		Model	Model
A	24 x 16	SC952150	SC952150B
A	36 x 24	SC952152	SC952152B
B	24 x 16	SC952154	SC952154B
B	36 x 24	SC952156	SC952156B
C	30 x 18	SC585342	SC585172B
C	36 x 24	SC585343	SC585344B
D	30 x 18	---	SC952168B

REPLACEMENT CASTERS-Set of 4

Model	Wheel
	Dia."
SC251444	3
SC251445	4

LIGHTWEIGHT PLASTIC DOLLY

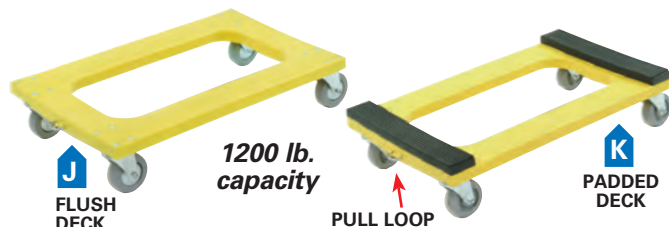

1200 lb. capacity

One piece 30"L x 18"W high-impact molded polyethylene dollies are lightweight and easy to clean. Will not rot, warp or splinter. Steel reinforced in critical areas for added strength. Four swivel non-marring rubber wheel casters assure easy mobility. Convenient steel loop allows dolly to be towed with a rope or chain. Choose **flush deck** or non-marring **rubber padded deck** for added cargo protection.

Style	4" CASTER-1000Lb. Cap		5" CASTER-1200Lb. Cap.	
	Model	Wt. Lbs.	Model	Wt. Lbs.
J	SC241344	14	SC241529	15
K	SC241345	16	SC241530	17

STEEL DOLLY



OPEN STEEL DECK

Move machinery or heavy cases and cartons. **Arc Welded Steel** dolly has 1 1/2" x 1 1/2" x 3/16" open deck frame with durable enamel finish and low profile 5" deck height.

Style	L" x W"	Cap.	Wheel	Model
		Lbs.		
L	27 x 16	1200	Rubber	SC952164
L	27 x 16	1600	Steel	SC952165
L	36 x 24	1200	Rubber	SC952166
L	36 x 24	1600	Steel	SC952167

HOW TO SELECT THE PROPER WHEELS AND CASTERS

1. SELECT WHEEL TYPE:

HARD RUBBER - Highly resistant to water, oil and animal fats. High load carrying ability and floor protection.
STEEL - Carbon steel casting. Unbreakable in normal service.
SEMI-PNEUMATIC - For light duty trailers, dollies or hand trucks. "Puncture-proof", no inner tube.
FULL PNEUMATIC - For handling delicate instruments or fragile parts. Floats loads over the roughest floors or obstructions.

MOLD-ON RUBBER - For full floor protection where greater capacities, load cushioning and less "load starting" effort is required.

MOLDED PLASTIC/POLYOLEFIN - For high impact, easy rolling, floor protection, and capacity. Resistance to many chemicals and heat.

POLYURETHANE - For longer wear, floor protection, high capacity and excellent cushioning.

2. DETERMINE LOAD CAPACITY per caster by adding load and truck weight and dividing result by number of supporting casters. For specific recommendations consult our engineering department.

3. WHEEL DIAMETER - The greater the wheel diameter, the easier it is to move.

FULL-PNEUMATIC CASTER

Transport delicate parts and materials virtually on air. Shock-absorbing, full pneumatic tired, roller bearing wheel absorbs vibrations which could be harmful to load, while protecting floors. Corrosion-resistant electroplated casters provide years of dependable service. 4 1/2" x 4" plate size with 2 5/8" to 3" x 3" to 3 5/8" bolt spacing. Gray rubber tires. (6" diameter casters are constructed of black rubber)

Cap. Lbs.	Dia."	Width /Ply	O.A. Ht."	SWIVEL	RIGID
				Model	Model
200	6	2.00/4	7 1/4	SC241532	SC241531
300	8	2.80/4	9 3/4	SC748042	SC748040
330	10	4.10/4	12 1/2	SC748046	SC748044

CASTER KIT - 2 Swivel, 2 Rigid. Capacity lbs. is per kit.
 1200 8 2.80/4 9 3/4 SC502592A



FLOOR LOCK

Mount to underside of platform trucks, lift tables and carts to help immobilize while loading or unloading. Simply step down to lock, step again to unlock. Corrosion resistant zinc-plated steel with 3" rubber footpad. 4 1/2" x 4" top plate with slotted holes for 2 5/8" to 3" x 3" to 3 5/8" mounting.

Model	For	Extended	Retracted
	Caster Dia."	Height"	Height"
SC241851A	4	5 3/4	5 1/16
SC241851B	5	6 5/8	5 5/8
SC241851C	6	7 5/8	6 5/8
SC241851D	8	9 5/8	8 5/8



Use when an economical caster is desired. Hardened steel balls roll in large raceway. 3" swivel caster has 4¹/₈" x 3¹/₈" plate size with 3³/₈" x 2³/₈" bolt spacing. 3" rigid caster has 5¹/₈" x 2¹/₄" plate size with 4" x 1³/₁₆" bolt spacing. 4" swivel caster has 5" x 4" plate size with 4" x 3" bolt spacing. 4" rigid caster has 6¹/₄" x 3¹/₄" plate size with 5" x 2" bolt spacing.

SWIVEL Model	Cap. Lbs.	Dia."	WHEEL		Material	RIGID Model
			Overall Width"	Ht."		
SC308500	150	3	1 ¹ / ₄	3 ⁷ / ₈	Hard Rubber	SC308508
SC308504	240	4	1 ¹ / ₂	5	Hard Rubber	SC308512



SC308508



SC308500

MEDIUM DUTY CASTER 200-290 lb. capacity

Ideal when increased capacity is required. Plain (PB) and Ball Bearing (BB) wheels ensure smooth, easy movement. 3⁵/₈" x 2¹/₂" plate size with 2⁷/₈" x 1³/₄" bolt spacing except models SC906230, SC906212 and SC502590A which have 4¹/₂" x 3³/₄" plate size with 2⁵/₈" to 3" x 3" to 3⁵/₈" bolt spacing.

SWIVEL Model	Cap. Lbs.	Dia."	WHEEL		Material	RIGID Model
			Overall Width"	Ht."		
SC906218	200	3 ¹ / ₂	1 ¹ / ₈	4 ³ / ₄	Soft Rubber PB	SC906200
SC906220	275	3 ¹ / ₂	1 ¹ / ₄	4 ³ / ₄	Hard Rubber PB	SC906202
SC906230	250	5	1 ¹ / ₄	6	Polyurethane BB	SC906212
SC906232	290	5	1 ¹ / ₄	6	Hard Rubber PB	SC906214
CASTER KIT - 2 Swivel, 2 rigid. Capacity lbs. is per kit						
	1000	5	1 ¹ / ₄	6	Polyurethane BB	SC502590A



SC906230



SC906232

SWIVEL Model	Cap. Lbs.	Dia."	WHEEL		Material	RIGID Model
			Overall Width"	Ht."		
SC748205	420	4	1 ¹ / ₂	5 ¹ / ₈	Molded Plastic	SC748305
SC748207	600	4	1 ¹ / ₂	5 ¹ / ₈	Polyurethane	SC748307
SC601108	500	5	1 ¹ / ₂	6 ¹ / ₂	Plastic	SC601208
SC601110	500	5	1 ¹ / ₂	6 ¹ / ₂	Polyurethane	SC601210
SC601112	350	5	1 ¹ / ₂	6 ¹ / ₂	Mold-on Rubber	SC601212
SC601118	800	6	2	7 ¹ / ₂	Plastic	SC601218
SC601120	800	6	2	7 ¹ / ₂	Polyurethane	SC601220
SC601122	500	6	2	7 ¹ / ₂	Mold-on Rubber	SC601222
SC601124	800	8	2	9 ¹ / ₂	Plastic	SC601224
SC601126	800	8	2	9 ¹ / ₂	Polyurethane	SC601226
SC601128	600	8	2	9 ¹ / ₂	Mold-on Rubber	SC601228
CASTER KIT - 2 Swivel, 2 rigid. Capacity lbs. is per kit						
	1400	5	1 ¹ / ₂	6 ¹ / ₂	Mold-on Rubber	SC241630
	2000	6	2	7 ¹ / ₂	Mold-on Rubber	SC241631
	2400	8	2	9 ¹ / ₂	Mold-on Rubber	SC502591A

HEAVY DUTY CASTER

350-800 lb. capacity

Ideal for general utility trucks, platform trucks, dollies, etc. Swivel casters have hardened double ball races and heat treated king bolt for longer life. Wheels roll easily on cage type hardened and ground roller bearings. Standardized 4¹/₂" x 4" top plate has slotted holes for 2⁵/₈" to 3" x 3" to 3⁵/₈" mounting.



SC601120

LO-PROFILE CASTER

Low profile design offers low load height and quick swivel response. Ideal for business machines, dollies and carts. Nylon bearing, powdered metal bushing and double ball bearing, heat-treated raceway. Non-marring casters and thread guards are standard. Durable zinc plated finish. 3³/₄" x 2³/₄" plate size with 3¹/₁₆" x 1³/₄" bolt spacing.

SWIVEL Model	Cap. Lbs.	Dia."	WHEEL		Material	RIGID Model
			Overall Width"	Ht."		
SC585501	175	2 ¹ / ₂	1 ¹ / ₈	3 ⁵ / ₁₆	Polyolefin	SC585502
SC585503	210	3	1 ¹ / ₄	3 ¹³ / ₁₆	Polyolefin	SC585504

LO-PROFILE
SWIVEL
SC585501



LO-PROFILE
RIGID
SC585502



HI-TECH DUAL LOCKING CASTER 400 lb. capacity

Unique patented dual braking system allows you to lock the caster in two ways. You can lock both the swivel and wheel rotation or just lock the caster swiveling feature, while still allowing the wheel to roll. Durable gray thermoplastic rubber construction is non-marring. Plate size 4¹/₂" x 4" with 3⁵/₈" x 2⁵/₈" bolt spacing.

Model	Dia."	Width"	Overall Ht."
SC585369	6	1 ³ / ₄	8

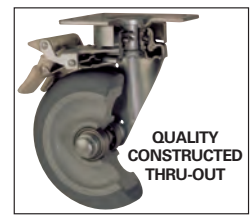

QUALITY
CONSTRUCTED
THRU-OUT

HAND TRUCK REPLACEMENT WHEEL KIT

Replace broken, faulty and ineffective wheels. Wheel kit includes two wheels, a 5/8" dia. x 18" L axle, 4 washers and 2 cotter pins. Add or subtract washers as necessary to adjust frame spacing. Fits most hand truck frames.

Model	Cap. Lbs.	Wheel Size"	Frame Width"	Wheel Material
SC906260	500	8 x 1 ³ / ₄	14 ⁵ / ₁₆ - 14 ⁵ / ₈	Mold-On Rubber
SC906262	500	10 x 2 ¹ / ₂	14 ³ / ₁₆ - 14 ¹ / ₂	Semi-Pneumatic
SC906261	500	10 x 3 ¹ / ₂	14 - 14 ⁵ / ₁₆	Pneumatic



MOLD-ON

SEMI-PNEUMATIC

PNEUMATIC

PLEASE CALL OUR ENGINEERING STAFF
FOR ASSISTANCE

01-800-467-0529

chproductos.com

67

ADJUSTABLE WIRE SHELF TRUCK DESIGNED FOR YEARS OF SERVICE

Maintenance-Free Genuine Chrome-Plated Finish; Superior to Zinc-Plated!

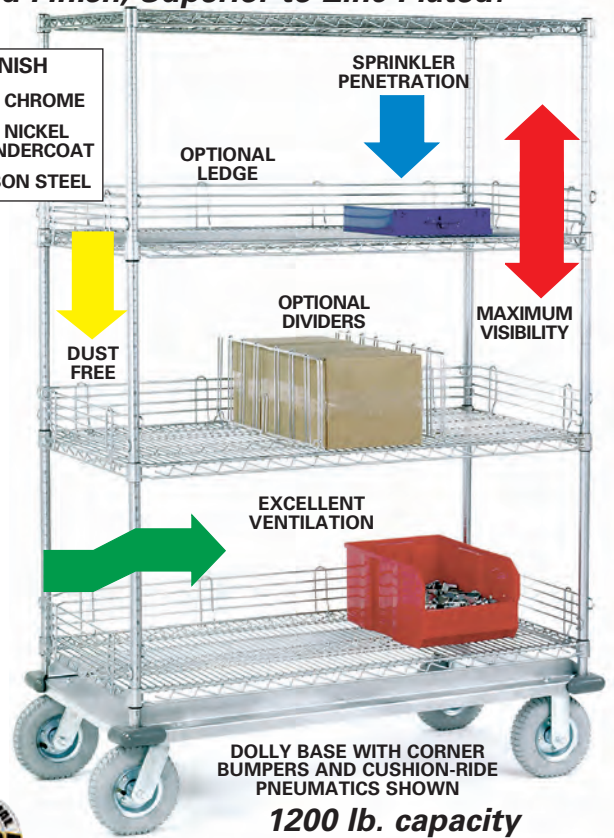

OPTIONAL ESD KIT
QUICK ASSEMBLY CLIP



1200 lb. capacity

Shelves adjust on 1" increments.
Numbered posts for quick assembly.



Super-strong 4 shelf wire trucks store and transport material safely and efficiently. 1Year Limited Warranty **against rust and corrosion when used in a dry storage application.** Open design minimizes dust accumulation, maximizes visibility, light penetration and air circulation. Ideal for warehouse, laboratory, factory, hospital, school or hotel use. Assembles quickly and easily without tools, shelves adjust instantly on 1" increments. Numbered posts allow quick positioning at desired height. Bright chrome-plated finish. Convenient 4-way access. Individual shelf capacity not to exceed 600 lbs.

1CASTERS WITH WHEEL BRAKE FOR ALL 5" DIA. WHEEL MODELS; ADD "B" TO MODEL.

**5" x 1 1/4" POLYURETHANE WHEEL†
SWIVEL CASTERS & DONUT BUMPERS
1200 LB. CAPACITY**

W" x D" x H"	Model
36 x 18 x 69	SC188500
48 x 18 x 69	SC188504
60 x 18 x 69	SC188508
72 x 18 x 69	SC188509
36 x 24 x 69	SC188512
48 x 24 x 69	SC188516
60 x 24 x 69	SC188520
72 x 24 x 69	SC188511
36 x 18 x 80	SC188502
48 x 18 x 80	SC188506
60 x 18 x 80	SC188510
72 x 18 x 80	SC188513
36 x 24 x 80	SC188514
48 x 24 x 80	SC188518
60 x 24 x 80	SC188522
72 x 24 x 80	SC188515

W" x D" x H**
36 x 18 x 63
48 x 18 x 63
60 x 18 x 63
36 x 24 x 63
48 x 24 x 63
60 x 24 x 63
36 x 18 x 74
48 x 18 x 74
60 x 18 x 74
36 x 24 x 74
48 x 24 x 74
60 x 24 x 74

**6" x 2" RUBBER (2 SWIVEL, 2 RIGID) TIRED WHEELS, DOLLY BASE AND CORNER BUMPERS
1600 LB. CAPACITY**

Model
SC188600
SC188602
SC188604
SC188606
SC188608
SC188610
SC188612
SC188614
SC188616
SC188618
SC188620
SC188622

8" x 2 1/2" FULL PNEUMATIC WHEELS (2 SWIVEL, 2 RIGID) FOR AIR CUSHIONED RIDE. DOLLY BASE AND CORNER BUMPERS. 1200 LB. CAPACITY

Model
SC188903
SC188905
SC188904
SC188906
SC188908
SC188910
SC188912
SC188914
SC188916
SC188918
SC188920
SC188922

*For overall height, add caster size plus 1".

DOLLY BASE WITH CORNER BUMPERS AND CUSHION-RIDE PNEUMATICS SHOWN

1200 lb. capacity

WIRE SHELF DIVIDERS-
Attaches at any point along shelf. Chrome.
L" x H" Model

18 x 8	SC188595B
24 x 8	SC188596B

DOCUMENT HOLDER- 12 3/8" L x 2" W x 8 5/8" H. Model SC579210A

ESD CONVERSION KIT- Includes conductive Aluminum Shelf Sleeves and dissipative ground chain Model SC241418A

Simply snap together and slide shelf over sleeve for positive locking.



WIRE LEDGES- Chrome. Prevents items from falling off.
L" x H" Model

18 x 4	SC188580H
24 x 4	SC188582H
36 x 4	SC188584H
48 x 4	SC188586H
60 x 4	SC188588H
72 x 4	SC188590H

PLEASE CALL OUR ENGINEERING STAFF FOR ASSISTANCE

DESIGN YOUR OWN WIRE TRUCK WITH THESE ACCESSORIES

A. SINGLE BOX SLIDE - Allows you to attach a tray below 18" or 24" deep wire shelf.

Model **SC339004A**

MULTI-BOX SLIDE - Create a storage area for trays within a shelving unit. Fits between any two 18" or 24" deep wire shelves spaced 22" apart. Slides spaced on 1 1/2" centers.

Model For Shelves

SC188591B	18" Deep
SC188592B	24" Deep

BOXES - 22" x 17" O.D. Gray polyethylene.

Model	Ht."	Model	Ht."
SC772036B	4 1/4	SC772042B	7
SC772040B	6	SC772048B	10

B. STEM CASTERS - Set of 4. Includes donut bumper. Attaches to bottom of post.

D" x W"	Description	Cap. Lbs.	Model
5 x 1 1/4	Polyurethane swivel	1200	SC585181
5 x 1 1/4	Polyurethane swivel 2 w/brake	1200	SC585182
5 x 1 1/4	Stainless Steel Construction		
8 x 2.80	Polyurethane swivel 2 w/brake	1200	SC241346
8 x 2.80	Full-pneumatic non-marring	1000	SC585183

C. PLATE CASTERS - For use with dolly base.

D" x W" H"	WHEEL	Cap. Lbs.	
		SWIVEL Model	RIGID Model
5 x 1 1/4 6	Polyurethane	250	SC585184
5 x 1 1/4 6	Polyurethane w/brake	250	SC585185
5 x 1 1/2 6 1/2	Mold-on Rubber	350	SC585186
6 x 2 1/2	Mold-on Rubber	500	SC585187
6 x 2 7 1/2	Polyurethane	800	SC585188
8 x 2.80 11	Full-pneumatic	300	SC585189

D. DOLLY BASE - Instantly creates a heavy duty mobile shelving unit or cart. Strong, durable formed chrome plated steel construction with corner bumpers. Order plate casters separately. Assembles easily.

Model	W" x D"	Model	W" x D"
SC585175	36 x 18	SC585178	36 x 24
SC585176	48 x 18	SC585179	48 x 24
SC585177	60 x 18	SC585180	60 x 24

E. KEYBOARD DRAWER - Attaches under shelf. Holds keyboards up to 21"W x 11"D. Has 6" Height adjustment. 25 1/4"W x 15"D x 4 1/4"H. Chrome.

Model **SC339042A** 63" HIGH 74" HIGH

F. NYLON COVER	W" x D"	Model	Model
Keep contents dust and dirt free. Made of water resistant 400 denier blue nylon with reinforced corners and double stitching for added durability. Two pockets allow 8 1/2" x 11" documents to travel with products. Simple hook and loop closure.	36 x 18	SC481100BL	SC481108BL
	48 x 18	SC481101BL	SC481109BL
	60 x 18	SC481102BL	SC481110BL
	72 x 18	SC481103BL	SC481111BL
	36 x 24	SC481104BL	SC481112BL
	48 x 24	SC481105BL	SC481113BL
	60 x 24	SC481106BL	SC481114BL
	72 x 24	SC481107BL	SC481115BL

G. POST - Chrome plated finish. Adjusts instantly on 1" increments.

Model	Ht."	Model	Ht."
SC188456A	14	SC188551A	63
SC188457A	34	SC188553A	74
SC188458A	54	SC188555A	86

H. WIRE SHELVES - Provide maximum air circulation. Chrome plated and reinforced for durability.

Model	W" x D"	Model	W" x D"
SC188550A	36 x 18	SC189970B	36 x 18
SC188552A	48 x 18	SC189971B	48 x 18
SC188554A	60 x 18	SC189972B	60 x 18
SC188562A	72 x 18	SC189973B	72 x 18
SC188556A	36 x 24	SC189974B	36 x 24
SC188558A	48 x 24	SC189975B	48 x 24
SC188560A	60 x 24	SC189976B	60 x 24
SC188564A	72 x 24	SC189977B	72 x 24
SC188542A	60 x 30		
SC188543A	72 x 30		

J. ADDITIONAL SHELF SLEEVES - Snap together on post and slide shelf over sleeve for positive locking. Sleeves are included with shelves.

Model **SC336374A**

K. DIVIDER - Separates items on shelf. Attaches easily at any point along shelf, simply hooks into place.

D" x H"	FOR WIRE SHELF		FOR SOLID SHELF	
	Model	Model	Model	Model
18 x 8	SC188595A	SC189980A	SC189980A	SC189981A
24 x 8	SC188596A			

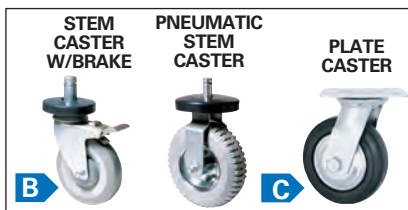

L. LEDGE FOR FRONT, BACK OR SIDES - 4" high. Prevents items from falling off. Chrome finish.

FOR WIRE SHELVES **FOR SOLID SHELVES**

Model	L"	Model
SC188580C	18	SC189982A
SC188582C	24	SC189983A
SC188584C	36	SC189985A
SC188586C	48	SC189986A
SC188588C	60	SC189987A
SC188590C	72	SC189988A

M. PUSH HANDLE - Chrome finish. Adjusts easily on 1" increments.

Size"	Model
18	SC703164
24	SC703165

N. DOCUMENT HOLDER - 12 3/8" x 2" x 8 5/8" H.

Model **SC489070E**

O. UTILITY BASKET - 17 3/8" x 7 1/2" x 10" H

Model **SC184798A**

P. LABEL HOLDER - Plastic snaps onto wire shelf and slide in any standard label 3"L x 1 1/4"H. Pkg. of 25 Model **SC481132A**

FOLD-UP SECURITY TRUCK

Protect Against Theft and Damage



FOLDS TO 6"

2000 lb. capacity

Completely enclose all types of merchandise. Lockable for maximum security. Conserve valuable floor space...folds to 6" thick. Constructed of 1" square tubing and heavy gauge 1" x 2" wire mesh. Top, bottom deck and center shelf are 1" sq. tubing covered with 20 ga. sheet metal for added strength and rigidity. Center shelf folds to allow storage of oversized cargo. Maneuvers easily on 6" x 2" hard rubber casters, 2 swivel with brakes, 2 rigid. Gray epoxy finish. 44 1/2"W x 27"D x 76"H overall. **Shipped Assembled.**

Model	Description
SC912114	Fold-Up Truck
SC959101E	Optional Keyed Padlock

QUICK ADJUST WIRE SHELF TRUCK

Adjustable In An Instant!



Unique shelf suspension hooks allow shelves to be added, removed or adjusted in seconds **without disassembling entire truck.** No tools required; simply lift shelf off post hooks and reposition to desired height. Chrome-plated, open wire shelving offers maximum visibility, light and sprinkler penetration while minimizing dust accumulation. Standard top and bottom shelves each have 600 lb. capacity for stability, while Quick-Adjust shelves have 400 lb. capacity each. **Truck has 1200 lb. overall capacity.** All shelves adjust on 1" increments on numbered posts. High capacity Dolly Base Trucks are available on www.globalindustrial.com.

OPTIONAL PUSH HANDLE

Model	Size"
SC331584B	18
SC331585B	24

OPTIONAL BRAKE CASTERS

OPTIONAL ESD KIT



4 SHELF TRUCK 5" x 1 1/4" SWIVEL POLYURETHANE WHEELS*

Model	W" x D" x H"	Model	W" x D" x H"
SC580550A	36 x 18 x 60	SC580554A	36 x 24 x 60
SC580551A	48 x 18 x 60	SC580555A	48 x 24 x 60
SC580552A	60 x 18 x 60	SC580556A	60 x 24 x 60
SC580553A	72 x 18 x 60	SC580557A	72 x 24 x 60
SC580558A	36 x 18 x 69	SC580562A	36 x 24 x 69

SC580559A	48 x 18 x 69	SC580563A	48 x 24 x 69
SC580560A	60 x 18 x 69	SC580564A	60 x 24 x 69
SC580561A	72 x 18 x 69	SC580565A	72 x 24 x 69

*Optional brake caster (2) add "B" to truck model number.

ADDITIONAL QUICK ADJUST SHELVES

Model	W" x D"	Model	W" x D"
SC580582A	36 x 18	SC580586A	36 x 24
SC580583A	48 x 18	SC580587A	48 x 24
SC580584A	60 x 18	SC580588A	60 x 24
SC580585A	72 x 18	SC580589A	72 x 24

ESD KIT - Includes conductive Aluminum Shelf Sleeves and dissipative Ground Chain. Model SC241418C

SECURITY STORAGE TRUCK

OPTIONAL ADDITIONAL QUICK ADJUST SHELVES UNHOOK TO ADJUST IN SECONDS



The mobility of a standard truck and the security of a lockable storage unit are combined for maximum versatility. Heavy gauge chrome plated 2 1/2" square wire mesh allows for visibility and air circulation, makes inventory control simple and minimizes dust accumulation. Dual hinged doors with padlock hasp for security. Additional Quick Adjust Shelves are available for greater shelf space. **Shelves can be added, removed or adjusted without disassembling truck.** Assembles easily.

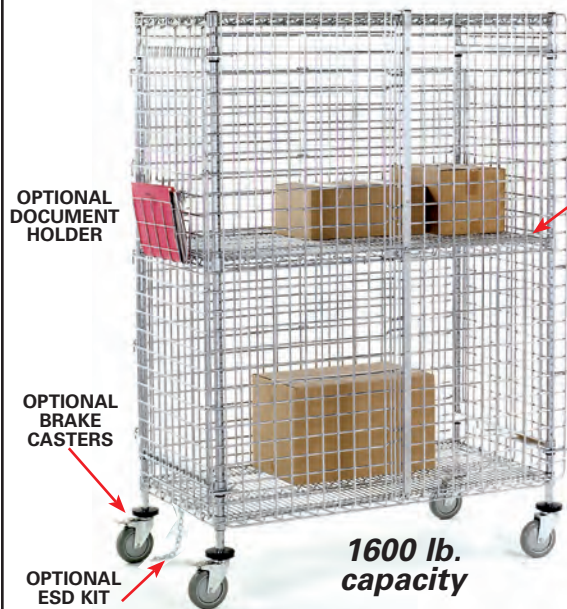

OPTIONAL QUICK ADJUST SHELF

OPTIONAL DOCUMENT HOLDER

OPTIONAL BRAKE CASTERS

OPTIONAL ESD KIT

1600 lb. capacity

SECURITY TRUCK
5" X 1 1/4" Polyurethane Wheel*
Swivel Casters & Donut Bumpers
1200 lb. Capacity-69"H

W" x D"	Model
36 x 14	SC334476
36 x 18	SC334477
36 x 24	SC184206
48 x 14	SC334478
48 x 18	SC334479
48 x 24	SC184207
60 x 24	SC334529

SECURITY TRUCK
6" x 2" Rubber Wheels (2 swivel, 2 rigid), Dolly Base & Corner Bumpers-1600 lb. Capacity-70"H

Model

SC241812
SC241813

SC241814
SC241815
SC241816

ADDITIONAL QUICK ADJUST SHELVES

Model
SC241290
SC241291
SC241292
SC241293
SC241294
SC241295
SC241296

*For optional brake casters (2) add "B" to truck model number.

SECURITY TRUCK ACCESSORIES

Model	Description
SC184210	Document Holder
SC959101H	Keyed Padlock
SC241418D	ESD Kit-Includes conductive Aluminum Shelf Sleeves and dissipative Ground Chain.



FOLDING STEEL SECURITY CART

1200 lb. capacity



FOLDS TO
12" WIDE

Cart provides secure storage for valuable equipment and supplies while allowing easy folding for compact storage. Doors and sides, top and bottom shelves all fold when empty for quick storage and reduced return freight space. Made using 21 gauge steel with a scratch-resistant light gray powder coat finish, and all panels and shelves are channel reinforced for extra strength. Padlockable swing arm for security (lock sold separately). Top is hinged to allow full access to compartment. Moves easily on 4" polyurethane swivel casters. Measures 30"L x 24"W x 35 1/4"H overall and folds to 30"L x 12"W x 35 1/4"H.

Model	Description
SC985417	Folding Security Cart
SC959101E	Keyed Padlock

NEST-A-WAY FOLDING TRUCK

1200 lb. capacity



OPTIONAL SHELF

Strong 16 gauge tubular steel frame folds and nests for space saving storage. 42" x 30" bottom shelf folds up and right side folds in forming an "L" shape for easy, compact storage. 6" x 2" mold-on rubber casters, 2 swivel, 2 rigid.

Optional shelf is 42"W x 30"D, has a 1000 lb. capacity and hangs onto trucks welded cross members. Durable gray enamel finish. 43"W x 32"D x 67"H overall. Easy assembly.

Model	Description
SC252750	Folding Truck
SC252759	Hook-On Shelf (3 Maximum per truck)

WIRE EXCHANGE AND TRANSPORT TRUCK

Up to 1000 lb. capacity

Quickly dispense and replenish supplies throughout your facility. **25 shelf label holders are included** for identification and organization. **Open Style Truck** has 4-way access to contents. **3-Sided Enclosed Truck** helps prevent items from falling off back and sides of shelves during transport. 800 lb. capacity truck has 5" polyurethane swivel casters with protective rubber donut bumpers. 1000 lb. capacity truck has sturdy dolly base with corner bumpers and 5" polyurethane swivel casters for heaviest loads. 69"H. Shelves adjust easily on 1" increments on numbered posts. **Galvanized Solid Shelves** are coated with clear epoxy for maximum corrosion resistance. **Genuine Chrome Wire Shelves** are electro-plated nickel-chrome offering excellent ventilation and maximum visibility for quick inventory. **Intermediate Quick Adjust Wire Shelves** have unique shelf suspension hooks that allow shelves to be added, removed or adjusted without disassembling entire truck. Assembles easily.

FOR ACCESSORIES SEE PAGE 69

W" x D"	OPEN-SIDED		3-SIDED ENCLOSED	
	800 LB. CAP. Model	1000 LB. CAP. Model	800 LB. CAP. Model	1000 LB. CAP. Model
TWO WIRE-ONE SOLID GALVANIZED SHELF TRUCK				
36 x 18	SC251281	SC251287	SC251293	SC251299
48 x 18	SC251282	SC251288	SC251294	SC251300
36 x 24	SC558812A	SC558830A	SC558815A	SC558833A
48 x 24	SC558813A	SC558831A	SC558816A	SC558834A
60 x 24	SC558814A	SC558832A	SC558817A	SC558835A
FIVE WIRE SHELF TRUCK (Includes 3 QUICK ADJUST wire shelves)				
36 x 18	SC251283	SC251289	SC251295	SC251301
48 x 18	SC251284	SC251290	SC251296	SC251302
36 x 24	SC558800A	SC558818A	SC558803A	SC558821A
48 x 24	SC558801A	SC558819A	SC558804A	SC558822A
60 x 24	SC558802A	SC558820A	SC558805A	SC558823A
FOUR WIRE-ONE SOLID GALVANIZED SHELF TRUCK (Includes 2 QUICK ADJUST wire shelves)				
36 x 18	SC251285	SC251291	SC251297	SC251303
48 x 18	SC251286	SC251292	SC251298	SC251304
36 x 24	SC558806A	SC558824A	SC558809A	SC558827A
48 x 24	SC558807A	SC558825A	SC558810A	SC558828A
60 x 24	SC558808A	SC558826A	SC558811A	SC558829A

FIVE WIRE SHELF
3-SIDED ENCLOSED
800 LB. CAPACITY
SC558805A



FOUR WIRE-ONE SOLID SHELF
3-SIDED ENCLOSED
1000 LB. CAPACITY
(SHOWN WITH OPTIONAL TRAY SLIDES)

TWO WIRE-ONE SOLID SHELF
OPEN STYLE TRUCK
1000 LB. CAPACITY
(SHOWN WITH OPTIONAL DIVIDERS)

FIVE WIRE SHELF
OPEN STYLE TRUCK
800 LB. CAPACITY



SC558829A



SC558832A



SC558802A

E-Z ADJUST BOLT-LESS SHELF TRUCK

Choice of Wood or Laminated Wood Shelves



DOUBLE RIVET BEAM FOR ADDED RIGIDITY

SC330422

1200 lb. capacity

Easy access to items from all sides. Super strong roll formed steel framing with positive interlocking beam and post connection. 2 1/4" x 1 1/2" x 14 gauge uprights. Choose rugged 5/8" thick particle board shelves or attractive, bright, easy to clean white melamine laminated 1/2" thick particle board shelves. Shelves are supported by steel beams that "quick adjust" on 1/2" increments. Strong 14 gauge angle iron dolly base. Durable gray baked enamel finish. All trucks have a 1200 lb capacity. Overall height with 5" wheels is 65", 8" wheel trucks are 68" high. Easy assembly.



EASY, SNAP-IN ASSEMBLY

CHOOSE THE WHEELS AND SHELVES TO SUIT YOUR NEEDS!



W" x D"	Shelf Qty.	POLYURETHANE 5" x 1 1/4" Wheels Model	RUBBER 8" x 2" Wheels Model	FULL PNEUMATIC 8" x 2 1/2" Wheels Model	ADDITIONAL SHELVES Model
WOOD SHELF					
36 x 18	4	SC585410	SC585411	SC585412	SC585457
36 x 18	5	SC585413	SC585414	SC585415	SC585457
36 x 24	4	SC585416	SC585417	SC585418	SC585458
36 x 24	5	SC585419	SC585420	SC585421	SC585458
48 x 24	4	SC585422	SC585423	SC585424	SC585459
48 x 24	5	SC585425	SC585426	SC585427	SC585459
60 x 24	4	SC983111	SC983112	SC983113	SC983114
60 x 24	5	SC983115	SC983116	SC983117	SC983114
LAMINATED WOOD SHELF					
W" x D"	Shelf Qty.	POLYURETHANE 5" x 1 1/4" Wheels Model	RUBBER 8" x 2" Wheels Model	FULL PNEUMATIC 8" x 2 1/2" Wheels Model	ADDITIONAL SHELVES Model
36 x 18	4	SC330410	SC330411	SC330412	SC330434
36 x 18	5	SC330413	SC330414	SC330415	SC330434
36 x 24	4	SC330416	SC330417	SC330418	SC330435
36 x 24	5	SC330419	SC330420	SC330421	SC330435
48 x 24	4	SC330422	SC330423	SC330424	SC330436
48 x 24	5	SC330425	SC330426	SC330427	SC330436
60 x 24	4	SC330428	SC330429	SC330430	SC330437
60 x 24	5	SC330431	SC330432	SC330433	SC330437

ADJUSTABLE SHELF CART



800 lb. capacity

SC188692

SHOWN WITH OPTIONAL PUSH HANDLE & DOCUMENT HOLDER AND ESD KIT



SC188892

Assembles quickly without tools. Shelves adjust at 1" increments. Numbered posts allow quick positioning at

desired height. Convenient 4-way access. 5" polyurethane wheel swivel casters with donut bumpers. Open Wire Chrome plated shelves minimize dust accumulation, maximize visibility and air circulation. Solid galvanized steel, 18 gauge, shelves are corrosion resistant for long life and double walled for maximum rigidity and strength. Overall height for all carts is 40".

W"x D"	2 SHELF CART		3 SHELF CART	
	OPEN	SOLID	OPEN	SOLID
36 x 18	SC188679	SC188879	SC188687	SC188887
48 x 18	SC188680	SC188880	SC188688	SC188888
60 x 18	SC188681	SC188881	SC188689	SC188889
72 x 18	SC188682	SC188882	SC188690	SC188890
36 x 24	SC188683	SC188883	SC188691	SC188891
48 x 24	SC188684	SC188884	SC188692	SC188892
60 x 24	SC188685	SC188885	SC188693	SC188893
72 x 24	SC188686	SC188886	SC188694	SC188894

PUSH HANDLE. Chrome finished handle aids in steering. Adjusts easily on 1" increments.

DOCUMENT HOLDER

Model SC489070A

ESD KIT. Includes conductive Aluminum Shelf Sleeves and dissipative Ground Chain. (For chrome wire carts only). Model SC241418B

72 More Products Available Online – chproducts.com

WIRE TRAY CART & TRUCK

600 lb. capacity

Open chrome-plated wire construction permits easy access and removal of contents. Allows maximum air circulation while minimizing dust accumulation. Rolls easily on 5" x 1 1/4" rubber swivel casters, 2 with brakes. Rubber bumpers help to protect walls. 1 1/2" spacing between shelves. **Accepts Optional Trays sold separately;** 40" H cart holds 19 Trays while 69" H Truck holds 39 Trays. Choose easy access 30" L x 18" W **Side-Load** style or 30" L x 21" W **End-Load** style for smaller work areas and aisles. **Optional Tray Stop Kit** available to help prevent trays from sliding out. **Optional ESD Conversion Kit** offers effective protection for handling PC boards and electronic components in assembly, package and storage areas.

Model	Description
SC168315	Side-Load Cart
SC168317	End-Load Cart
SC168316	Side-Load Truck
SC168318	End-Load Truck
Tray Stop Kit - requires 2 per Cart or Truck.	
SC168319	Fits Side or End Cart
SC168320	Fits Side or End Truck
ESD Conversion Kit - Includes conductive Aluminum Shelf Sleeves and dissipative ground chain. For Carts or Trucks.	
SC241288	ESD Kit



SC168317 END-LOAD CART WITH TRAY STOP KIT



SC168316 SIDE-LOAD TRUCK WITH ESD KIT, ESD TRAYS & TRAY STOP KIT

OPTIONAL TRAYS - 26" x 18" trays are temperature resistant from -60° to 250° F. **Standard Trays** are molded of off-white Fiberglass and have reinforced edges for extra strength. **ESD Conductive Trays** are molded of black thermo-set composite material with permanent surface resistivity of 10^5 ohms/sq.

Model	Tray Style
SC585301	Standard
SC241289	ESD

GALVANIZED OR STAINLESS STEEL SHELF TRUCK

Choose between 18 gauge clear epoxy coated galvanized steel or Type 304 stainless steel shelves. Shelves are corrosion resistant, adjust at 1" increments and feature a raised shelf edge to keep items from falling during transport. 5" diameter polyurethane swivel casters feature donut bumpers to help protect walls. Individual shelf capacity not to exceed 400 lbs. Fast, easy assembly. High capacity Dolly Base Trucks are available on globalindustrial.com. Casters with wheel brakes available. Add "B" to model.



STAINLESS STEEL TRUCK SHOWN WITH OPTIONAL ACCESSORIES AND BRAKE CASTERS

OPTIONAL ACCESSORIES	
CHROME PUSH HANDLE	
Model	Size"
SC703164G	18
SC703165G	24
SHELF LEDGES, 4"H.	
Prevent items from falling. Chrome finish.	
Model	Size"
SC189982B	18
SC189983B	24
SC189984B	30
SC189985B	36
SC189986B	48
SC189987B	60
SC189988B	72
WIRE SHELF DIVIDER, 8"H.	
Chrome finish	
Model	D"
SC189980E	18
SC189981E	24
DOCUMENT HOLDER.	
12 ³ / ₈ " x 2" x 8 ⁵ / ₈ "H.	
Model	
SC489070B	

W" x D" x H"	4 SHELF TRUCK Model	ADDITIONAL SHELVES Model
GALVANIZED SHELVES		
36 x 18 x 69	SC489042	SC189970C
48 x 18 x 69	SC489043	SC189971C
60 x 18 x 69	SC489044	SC189972C
72 x 18 x 69	SC489045	SC189973C
36 x 24 x 69	SC489046	SC189974C
48 x 24 x 69	SC489047	SC189975C
60 x 24 x 69	SC489048	SC189976C
72 x 24 x 69	SC489049	SC189977C
36 x 18 x 80	SC489052	SC189970C
48 x 18 x 80	SC489053	SC189971C
60 x 18 x 80	SC489054	SC189972C
72 x 18 x 80	SC489055	SC189973C
36 x 24 x 80	SC489056	SC189974C
48 x 24 x 80	SC489057	SC189975C
60 x 24 x 80	SC489058	SC189976C
72 x 24 x 80	SC489059	SC189977C
STAINLESS STEEL SHELVES		
36 x 18 x 69	SC585110	SC585119
36 x 24 x 69	SC585111	SC585120
48 x 24 x 69	SC585112	SC585121
36 x 18 x 80	SC585113	SC585119
36 x 24 x 80	SC585114	SC585120
48 x 24 x 80	SC585115	SC585121
36 x 18 x 92	SC585116	SC585119
36 x 24 x 92	SC585117	SC585120
48 x 24 x 92	SC585118	SC585121

EUROPEAN STYLE DECK TRUCK



SHOWN WITH OPTIONAL DOCUMENT HOLDER

SECURITY TRUCK

Transport materials easily and securely. Sturdy 1¹/₂" x 1¹/₈" angle iron frame has rounded safety edges and is finished in scratch resistant blue enamel. Rugged 3⁴/₄" thick plywood decking with lacquer finish helps reduce noise during transport. Wire panels 23"H with 2¹/₄" DP grids allow for air circulation and inventory control. **Security Truck Model** can be locked with optional padlock to protect contents. Each truck includes 2 swivel and 2 rigid casters. Cross-braced 29"H dual handles (except Style A one handle). Assembles easily.

Description	Style	L" x W"	2000 LB. CAP. MOLD-ON RUBBER	2400 LB. CAP. MOLD-ON RUBBER	1200 LB. CAP. FULL PNEUMATIC
			6" x 2" WHEELS Model	8" x 2" WHEELS Model	8" x 2 ¹ / ₂ " WHEELS Model
WOOD SIDES AND DECK					
Flat Deck	A	48 x 24	SC241501	SC952661	SC952662
Flat Deck	A	60 x 30	SC241502	SC952664	SC952665
Closed Ends	B	48 x 24	SC241503	SC952667	SC952668
Closed Ends	B	60 x 30	SC241504	SC952670	SC952671
Three Sides	C	48 x 24	SC241505	SC952673	SC952674
Three Sides	C	60 x 30	SC241506	SC952676	SC952677
Four Sides	D	48 x 24	SC241507	SC952679	SC952680
Four Sides	D	60 x 30	SC241508	SC952682	SC952683
WIRE SIDES WITH WOOD DECK					
Three Sides	E	48 x 24	SC241509	SC952685	SC952686
Three Sides	E	60 x 30	SC241510	SC952688	SC952689
Four Sides	F	48 x 24	SC241511	SC952691	SC952692
Four Sides	F	60 x 30	SC241512	SC952694	SC952695
Security Truck	G	48 x 24	SC241513	SC184300	SC184302
Security Truck	G	60 x 30	SC241514	SC184301	SC184303

OPTIONAL ACCESSORIES

Model	Description
SC489070D	Document Holder
SC959101C	Keyed Padlock

PLASTIC SERVICE CART

"The Industry Standard"

BEST PRICE ANYWHERE!



OPTIONAL
LOCKING
DRAWER

SC241567

OPTIONAL
REFUSE BIN

500 lb.
capacity

OPTIONAL ACCESSORIES

Model	Description
SC241581*	Utility Bin 21" L x 2 1/2" W x 4" H
SC241678*	Hook-On Refuse Bin 14" W x 10" D x 19" H
SC241720*	Locking Steel Drawer 10 3/4" W x 18" D x 4 1/2" H
SC241635	3 Outlet Power Strip with 10' cord

*Does Not Fit SC241749 Tray Cart

Rugged structural plastic cart for all types of applications including industrial, medical and food preparation. Won't rust, dent, peel or chip, is easily cleaned and is virtually maintenance free. 3" deep trays (except Model SC241749 with 2 1/2" trays) with leak-proof top shelf. Comfort-grip push handle allows easy steering. Lightweight cart rolls easily on 2 swivel, 2 rigid non-marking casters. Choose **Optional Full-Pneumatic Wheels** for a soft ride and easy rolling over rough surfaces. Personalize your cart with our great accessories. Assembles easily.



SC241568

OPTIONAL
UTILITY BIN
SC241581

Model	Description	Overall L" x W" x H"	Shelf Qty.	Wheel Type
SC241749		34 x 17 1/2 x 33	2	5" Rubber
SC498526		40 x 26 x 33	2	5" Rubber
SC241567		40 x 26 x 38	2	8" Pneumatic
SC241568		40 x 26 x 33	3	5" Rubber
SC241569		40 x 26 x 38	3	8" Pneumatic



FLAT SHELF SERVICE CART

Durable structural plastic cart is easily cleaned and virtually maintenance free! Smooth, level Flat Top Shelf is ideal for loading and unloading oversized cargo. Lower shelf offers a 3" deep tray (except Model SC985087 with 2 1/2" tray) to help retain cargo during transit. Comfortable ergonomically designed push handle allows easy steering. Lightweight cart rolls easily on 2 swivel, 2 rigid non-marking casters. Choose **Optional Full Pneumatic Wheels** for a soft ride and easy rolling over rough surfaces. Personalize your cart with our great accessories. Assembles easily.

Model	Overall L" x W" x H"	Shelf Qty.	Wheel Type
SC985087	34 x 17 1/2 x 33	2	5" Rubber
SC498529	40 x 26 x 33	2	5" Rubber
SC241587	40 x 26 x 38	2	8" Pneumatic
SC241588	40 x 26 x 33	3	5" Rubber
SC241589	40 x 26 x 38	3	8" Pneumatic

500 lb.
capacity

OPTIONAL ACCESSORIES

Model	Description
SC241581A*	Utility Bin 21" L x 2 1/2" W x 4" H
SC241678A*	Hook-On Refuse Bin 14" W x 10" D x 19" H
SC241720A*	Locking Steel Drawer 10 3/4" W x 18" D x 4 1/2" H
SC241868	3 Outlet Power Strip with 10' cord

* Does Not Fit SC985087 Flat Shelf Cart



SC498529

DELUXE PLASTIC SERVICE CART

Versatile cart offers **molded-in tool storage trays, cup holder and towel rack** conveniently located in the ergonomically designed push handle. Heavy duty, tough structural foam plastic construction resists scratches, dents and cleans easily. 3" deep trays help to retain cargo during transit. Lightweight, quiet rolling cart maneuvers easily on 2 swivel, 2 rigid casters. Choose **Optional Full Pneumatic Wheels** for a soft ride and easy rolling over rough surfaces. Assembles easily.



Model	Overall L" x W" x H"	Shelf Qty.	Wheel Type
SC242080	40 x 17 x 33	2	31 x 17 5" Rubber
SC242082	40 x 17 x 35	2	31 x 17 6" Pneumatic
SC242083	40 x 17 x 33	3	31 x 17 5" Rubber
SC242084	40 x 17 x 35	3	31 x 17 6" Pneumatic
SC242081	46 x 25 x 33	2	37 x 25 5" Rubber
SC242085	46 x 25 x 35	2	37 x 25 6" Pneumatic
SC242086	46 x 25 x 33	3	37 x 25 5" Rubber
SC242087	46 x 25 x 35	3	37 x 25 6" Pneumatic

PUSH HANDLE
HAS
MOLDED-
IN TOOL
STORAGE
TRAYS AND
CUP HOLDER

OPTIONAL ACCESSORIES

Model	Description
SC241581C*	Utility Bin 21" L x 2 1/2" W x 4" H
SC241678C*	Hook-on Refuse Bin 14" W x 10" D x 19" H
SC241868B	3 Outlet Power Strip with 10' cord

*Only fits 46" L x 25" W Carts



500 lb. capacity



SC242087

MOBILE WORK CENTER

Rugged structural plastic cart has steel locking doors and sides with steel pegboard at both ends for secure storage and organization. Cable management opening allows cart to be used as a mobile charging station for rechargeable tools. Pegboard end panel prevents heat build-up from electronics, and casters allow cart to be parked near electric outlets. When charging is complete, simply unplug and go.

Steel enclosure secures valuables with 2 point locking mechanism that captures and locks both doors. Locking chrome door handle includes 2 keys. Perforated end panels serve as a pegboard with handy organizing hooks (sold separately). Gray powder coat finish and gray structural foam. Choose **Tray Shelf** with 3" deep leak-proof top or **Flat Shelf** style. All include molded-in push handle with 2 swivel, 2 fixed non-marking casters. Choose optional **Pneumatic Wheels** for a cushioned ride. Assembles easily.

500 lb. capacity

Model	Style	Wheel Type	L" x W" x H"
SC241864	Tray Shelf	5" Rubber	40 x 26 x 33
SC241865	Tray Shelf	8" Pneumatic	40 x 26 x 38
SC241866	Flat Shelf	5" Rubber	40 x 26 x 33
SC241867	Flat Shelf	8" Pneumatic	40 x 26 x 38
SC241868A	Optional 3 Outlet Power Strip		
SC241869	Optional 30 PC. Pegboard Hook Kit		



**FLAT SHELF
SC241867**



**TRAY SHELF
SC241864**

**SHOWN WITH
OPTIONAL ACCESSORIES**

WIRE UTILITY CART

800 lb. capacity

All purpose cart has 1001 uses. Bright chrome plated finish, open wire construction allows air circulation, reduces dust and dirt build-up. Adjustable shelves. 5" polyurethane wheel swivel casters with protective bumpers. Optional snap-on ledges help to prevent fall-off, ledges stack to create a basket effect. 38" high. Assembles easily.

DOCUMENT HOLDER

Model **SC489070N**

ESD KIT - Includes conductive Aluminum Shelf Sleeves and dissipative Ground Chain.

Model **SC241418F**

L" x W"	4"H LEDGES		Model	Size"
	2 SHELF Model	3 SHELF Model		
36 x 18	SC188704	SC188724	SC188580B	18
36 x 24	SC188708	SC188728	SC188582B	24
48 x 24	SC188710	SC188730	SC188584B	36
			SC188586B	48



**SC188704
SHOWN WITH
OPTIONAL
DOCUMENT HOLDER,
LEDGES AND ESD KIT**



SC188724

FOLD-A-WAY STOCK CART

750 lb. capacity

Heavy-duty stock cart offers easy transport and removal of contents. High side walls contain cargo. **Folds easily to 18" deep for compact storage.** Convenient latch holds cart in folded position. Durable 14 gauge steel construction with 1" tubular frame and handle. Open wire 3 1/2" x 3 1/2" grid allows visibility to contents. Folding, smooth top shelf provides additional storage space. 25" clearance between shelves. Bottom shelf features slip resistant tread plate surface. Features two 5" polyurethane swivel casters and two 8" axle mounted thermoplastic rubber wheels for easy mobility. 38"L x 28"W x 39"H overall with chip resistant blue powder coat finish. Easy assembly.

Model
SC242026

**FOLDS TO
18" FOR
COMPACT
STORAGE**



**INCLUDES
FOLDING TOP
SHELF**



MAIL/SERVICE CART with Removable Baskets



SC168030



250 lb. capacity

Collect and deliver mail, packages, inventory and tools. **Removable baskets make sorting and loading simple.** Heavy duty 18 gauge x 1" diameter tubular steel construction is chrome plated for long life. File rails included to accommodate hanging files. Carts feature non-marring wheels, two 5" dia. rubber swivel casters and two 10" semi-pneumatic rear wheels. Cushioned push handle for comfort. **STANDARD CART** has a 25"L x 17 1/4"W x 11"D upper basket and a 25"L x 17 1/4"W x 7 1/2"D lower basket. **DELUXE CART** has a 36"L x 17 1/4"W x 11"D upper basket and a 36"L x 17 1/4"W x 7 1/2"D lower basket. Easy assembly.

Model	Description	L" x W" x H"	Cap. Lbs.
SC168029	Standard Cart	33 x 24 x 38	200
SC168030	Deluxe Cart	43 x 24 x 38	250

WIRE SHELF INSTRUMENT CART



SC188780

1200 lb. capacity

SHOWN WITH
OPTIONAL DOCUMENT
HOLDER, LEDGES
AND ESD KIT

Securely transport and store valuable, sensitive equipment. Ideal for bulky items, too. Nickel chrome-plated wire is attractive and rust resistant. Non-conductive 0.035" clear polypropylene shelf liners included. Shelves are adjustable on 1" increments. Shock absorbing 8" pneumatic wheels (2 swivel, 2 rigid) are smooth rolling and highly maneuverable. Donut bumpers help protect walls. 44" overall height. Assembles easily.

L" x W"	2 SHELF Model	3 SHELF Model
36 x 24	SC188780	SC188786
48 x 24	SC188782	SC188788
60 x 24	SC188784	SC188790

4"H LEDGES

Size"	Model	Size"	Model
24	SC188582D	48	SC188586D
36	SC188584D	60	SC188588D

DOCUMENT HOLDER

Model
SC489070F

ESD KIT - Includes conductive Aluminum Shelf Sleeves and dissipative Ground Chain.
Model **SC241418E**

76 [More Products Available Online – chproducts.com](http://chproducts.com)

STAINLESS STEEL UTILITY CART

400 lb. capacity



Simply the best stainless steel cart value on the market! Ideal for use in clean rooms, restaurants and other corrosive environments. Premium 304 polished stainless steel throughout, with 20 gauge shelves and strong 16 gauge shelf uprights for years of service. 24"L x 16 1/4"W x 33"H with 12" clearance between shelves. Top and middle shelves have 1 1/4" lips on 3 sides to help retain cargo during transit, while flush lower shelf is ideal for oversized items. Comfortable tubular push handle. Rolls smoothly on four 4" swivel non-marring rubber casters, 2 with brakes. Assembles easily.

Model SC241586

PICKING & DISTRIBUTION UTILITY CART



REMOVABLE
LOWER BASKET

200 lb. capacity

Ideal for pickup and distribution of parts, tools, mail, etc. Rugged 1" round tubular steel frame. Extra large heavy duty welded steel baskets transport bulky items easily. 36" x 16" x 11"H upper basket. Removable 35" x 15 1/4" x 7"H lower basket. File rails included to accommodate hanging files. Two 4" swivel rubber wheel casters in front. Two rigid semi-pneumatic wheels in back for easy mobility. 44"L x 22"W x 35"H. Nickel-chrome plated. Assembles easily.

Model SC500154

FOLD-N-STORE SERVICE CART

350 lb. capacity



Folds down compactly for easy, out of the way storage. Chrome plated 1" steel tubing construction with a laminated plastic top. Handy 21"L x 13"W x 3" H heavy duty wire storage basket included. Four swivel 4" polyurethane ball bearing casters offers easy mobility. 28"L x 19"W x 29"H overall and folds to 44"L x 19"W x 12"H. Assembles in minutes.

Model
SC912110

GALVANIZED OR STAINLESS STEEL UTILITY CART



800 lb. capacity



SC184285 SHOWN WITH OPTIONAL ACCESSORIES

Durable, corrosion resistant carts are perfect for hospitals, clean rooms and labs. **Galvanized models** have 18 gauge steel shelves with clear epoxy coating to provide years of service. **Stainless steel models** offer Type 304 stainless steel shelves for maximum rust resistance. Choice of 2 or 3 shelf carts; shelves adjust on 1" increments on numbered posts to accommodate various sized loads. Handles have a bright, chrome plated finish. 5" x 1 1/4" polyurethane swivel casters with donut bumpers to help protect walls. 38"H. Easy assembly.

L" x W"	2 SHELF		3 SHELF		SHELF LEDGES. 4"H/ Chrome.	
	Model	Model	Model	Model	Model	Size"
GALVANIZED SHELF						
36 x 18	SC489062		SC489065		SC189982E	18
36 x 24	SC489063		SC489066		SC189983E	24
48 x 24	SC489064		SC489067		SC189985E	36
					SC189986E	48
STAINLESS STEEL SHELF						
36 x 18	SC184285		SC184288		DIVIDERS. 8"H. Chrome.	
36 x 24	SC184286		SC184289		Model	W"
48 x 24	SC184287		SC184290		SC189980F	18
DOCUMENT HOLDER Model		SC489070P			SC189981F	24

BEST VALUE BELLMAN CART

These luggage carts provide an attractive appearance for hotels while maintaining strength and durability. #201 stainless steel uprights and framing offer excellent corrosion resistance. Tubular frame is cross-braced for added reinforcement and includes garment bar for hanging wardrobe. Slip-resistant red carpeted plywood deck protects luggage and has a perimeter bumper to protect walls. Moves easily on 2 swivel, 2 rigid casters. Assemble easily. **Specify upright color suffix: Gold Plated (GD) or Silver Stainless (SL) finish.**



1100 lb. capacity

L" x W" x H"	Wheel Type	UPRIGHT STYLE	
		STRAIGHT Model	CURVED Model
41 x 24 x 73	6" Rubber	SC985116SL	SC985118SL
41 x 24 x 73	6" Rubber	SC985116GD	SC985118GD
41 x 24 x 75	8" Pneumatic	SC985117SL	SC985119SL
41 x 24 x 75	8" Pneumatic	SC985117GD	SC985119GD

VINYL AND CANVAS BULK TRUCK

Perfect for warehouse, laundry or mail, these durable trucks get the job done. **Includes elastic band nylon cap to help contain and protect contents.** Strong Kiln-dried hardwood base, welded steel frame and 4" swivel non-marking rubber casters easily move heavy loads. Wear-guard edge offers maximum abrasion protection. Two large document pockets and twin reinforced pull handles. **Choice of fabric body: VINYL** coated nylon body, available in Blue or Yellow, offers a smooth, puncture resistant, and easily cleaned surface. **CANVAS** body affords maximum abrasion resistance and durability. Heavyweight canvas is treated with water repellent to resist weather and liquid damage. Shipped assembled. **Specify Vinyl Truck color suffix: (BL) Blue or (YL) Yellow.**



INCLUDES FREE NYLON CAP



VINYL TRUCK SC241985YL



CANVAS TRUCK SC241305

Cap Bushel	Inside		O.A. H"	VINYL TRUCK	CANVAS TRUCK	REPLACEMENT LINER	
	L" x W" x H"	Model		Model	VINYL Model	CANVAS Model	
8	34 x 22 3/4 x 23 1/2	30 1/4	SC241982	SC241302	SC241987	SC241315	
12	36 1/4 x 24 3/4 x 25 1/2	32 1/4	SC241983	SC241303	SC241988	SC241316	
16	40 x 28 1/4 x 30 1/2	37 1/4	SC241984	SC241304	SC241989	SC241317	
20	48 x 32 x 30 1/2	37 1/4	SC241985	SC241305	SC241990	SC241318	
24	53 1/4 x 36 1/4 x 30 1/2	37 1/4	SC241986	SC241306	SC241991	SC241319	

HOPPER FRONT BULK TRUCKS

Cutaway Design Speeds Loading and Unloading!

Bulk Linen Trucks are designed to be reliable workhorses for commercial laundries and distribution companies serving hospitals, nursing homes, hotels and other institutions. Rugged, seamless rotationally molded polyethylene (LLDPE) truck has smooth walls for easy cleaning, and thrives in punishing indoor or outdoor conditions. Convenient cutaway opening offers easy access for loading/unloading of goods, and integral hand holes in the body offer easy steering. **Security Truck** has folding white plastic closure panels with a padlock hasp for securely storing contents. Padlock not included. Rolls easily on 6" non-marring rubber wheel casters (2 swivel, 2 rigid). **Specify color suffix: (BL) Blue, (GN) Green, (GY) Gray or (RD) Red.**



BULK TRUCK SC987556BL



SECURITY TRUCK SC987557RD

Type	Cap.		Overall Dim. L" x W" x H"	Model
	Cu. Ft.	Lbs.		
Bulk Truck	43	500	46 3/4 x 27 1/2 x 64	SC987556
Security Truck	43	500	46 3/4 x 27 1/2 x 64	SC987557

DELUXE TILT TRUCK *Holds Up to 2100 lbs.*

**1/2 CUBIC YARD
750 LBS. CAPACITY**



SC984613
SHOWN WITH
OPTIONAL LID SC984612



CONVENIENT
PUSH HANDLE
WITH TRASH
BAG HOOKS



INTEGRAL TILT
HANDLE



PUSH HANDLE WITH
TRASH BAG HOOKS



ALL-WELDED
STEEL CHASSIS

**STANDARD DUTY
1000 LBS. CAPACITY**



SC501600
STANDARD
DUTY



Online
Video
& Photos

**HEAVY DUTY
1250 LBS. CAPACITY**



SC242089
BLUE RECYCLE TRUCK



CONVENIENT TILT
HANDLE



STEEL FRAME SUPPORTS
TRUCK DURING TILT

EXTRA HEAVY DUTY 2100 LBS. CAPACITY



STRONG
FRAME
SUPPORTS
HEAVY
LOADS

STEEL
IMPACT
NOSE
PLATE



Online
Video
& Photos



VINYL UTILITY BAG*
SC251582

SC242096
SHOWN WITH
OPTIONAL LID
SC241969

Ruggedly built for transporting and dumping bulky materials. One piece seamless molded polyethylene body cleans easily, won't dent, corrode or absorb moisture. Convenient push and lift handles provide secure handling. Push handle includes integrated trash bag hooks.

1/2 Cubic Yard Trucks feature two 9" roller bearing mold-on rubber load wheels and two 4" polyurethane swivel casters.

1 Cubic Yard Standard Duty Trucks feature two 8" roller bearing plastic load wheels and two 4" plastic swivel casters.

Heavy Duty 1 Cubic Yard Trucks offer steel extended support rails to help prevent bulging while under load, two 12" roller bearing mold-on rubber load wheels and two 5" rubber swivel casters for easy rolling of heavy loads.

Extra Heavy Duty 1 Cubic Yard Trucks incorporate the features of the Heavy Duty Trucks plus offer upper steel extended support rails and a steel impact nose plate to protect the nose of the truck for the heaviest loads.

Blue Trucks include a white "We Recycle" logo on both sides. **Optional Hinged Gray Lid** helps control odors and protect cargo. Allows access to cargo without removal.

9 Pocket Vinyl Utility Bag easily attaches to 1 cu. yd. tilt trucks using straps and ties to carry various cleaning products and supplies. Measures 19"W x 27"H overall. (*Does not fit 1/2 cu. yd. Models).

Model	Description	Cap. Lbs.
1/2 CUBIC YARD TILT TRUCK - 46 1/2" L x 31" W x 33" H - Assembles Easily		
SC984613	Gray Truck	750
SC984614	Blue Truck	750
SC984612	Gray Lid for 1/2 Cu. Yd. Tilt Trucks	
1 CUBIC YARD TILT TRUCK - 70" L x 35" W x 41 1/2" H - Shipped Assembled		
SC501600	Standard Duty Gray Truck	1000
SC501600BK	Standard Duty Black Truck	1000
SC501600RD	Standard Duty Red Truck	1000
SC242088	Heavy Duty Gray Truck	1250
SC242088BK	Heavy Duty Black Truck	1250
SC242088RD	Heavy Duty Red Truck	1250
SC242096	Extra Heavy Duty Gray Truck	2100
SC242096BK	Extra Heavy Duty Black Truck	2100
SC242096RD	Extra Heavy Duty Red Truck	2100
SC241847	Standard Duty Blue Truck	1000
SC242089	Heavy Duty Blue Truck	1250
SC242097	Extra Heavy Duty Blue Truck	2100
SC241969	Gray Lid 1 Cu. Yd. Tilt Trucks	
SC251582	9 Pocket Vinyl Utility Bag	

RECYCLING TILT TRUCKS *Holds up to 2100 lbs.!*

**1/2 CUBIC YARD
750 LBS. CAPACITY**



SC240924



**LIFTING HANDLE
FOR EASY
EMPTYING**

**STANDARD DUTY
1000 LBS. CAPACITY**



**PUSH HANDLE
WITH TRASH
BAG HOOKS**



SC501601
SHOWN WITH
OPTIONAL LID
SC237649

**HEAVY DUTY
1250 LBS. CAPACITY**



SC237872



**STEEL FRAME
SUPPORTS TRUCK
DURING TILT**

EXTRA HEAVY DUTY 2100 LBS. CAPACITY



Online
Video
& Photos



SC237899



**CONVENIENT
TILT HANDLE**



VINYL UTILITY BAG

Transports and dumps bulky recyclable materials. One piece seamless molded polyethylene body cleans easily, won't dent, corrode or absorb moisture. Steel chassis provides maximum support. Convenient push and lift handles provide secure handling. Push handle includes integrated trash bag hooks. Features a white "We Recycle" logo on both sides.

Standard 1/2 Cu. Yd. Truck features two 9" axle mounted rubber wheels and two 4" plastic swivel casters.

Standard 1 Cu. Yd. Truck features two 8" plastic wheels and two 4" plastic swivel casters.

Heavy Duty 1 Cu. Yd. Truck offers steel support rails, two 12" mold-on rubber wheels and two 5" rubber swivel casters.

Extra Heavy Duty 1 Cu. Yd. Truck has the features of the Heavy Duty truck plus offers upper steel support rails and a steel impact nose plate.

Optional Hinged Lid helps control odors and hides cargo.

Utility Bag easily attaches to 1 cu. yd. tilt truck using straps and ties to carry various cleaning products and supplies. Measures 19"W x 27"H overall. (Does Not Fit 1/2 Cu. Yd. Model).

Model	Description	Cap. Lbs.
SC240924	1/2 CUBIC YARD TILT TRUCK - 46 1/2"L x 31"W x 33"H - Assembles Easily	750
SC240925	Standard 1/2 Cu. Yd. Tilt Truck	
	Gray Lid for 1/2 Cu. Yd. Tilt Truck	
SC501601	1 CUBIC YARD TILT TRUCK - 70"L x 35"W x 41 1/2"H - Shipped Assembled	1000
SC237872	Standard 1 Cu. Yd. Tilt Truck	1250
SC237899	Heavy Duty 1 Cu. Yd. Tilt Truck	2100
SC237649	Extra Heavy Duty 1 Cu. Yd. Tilt Truck	
SC240705	Gray Lid for 1 Cu. Yd. Tilt Trucks	
	9 Pocket Vinyl Utility Bag	

GLOBAL® PLASTIC RECYCLING CONTAINERS

Made using corrosion resistant polypropylene. Containers offer a 15 gallon capacity. Includes built-in grip handle for easy lifting. Measures 12"W x 18"D x 24"H overall. Add an **Optional Lid** (sold separately) with designated restricted openings that

help prevent unwanted waste disposal. Lid options are Swing Trash Lid, Bottle & Can Lid, or Paper Slot Lid. Combine 3 containers with 3 different lid styles to create a recycling station. **Specify Color Suffix: Gray (GY) or Green (GN).**



SWING TRASH LID



BOTTLE & CAN LID

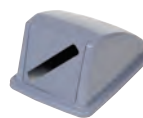

PAPER LID

Model	Description	W"x D" x H"	Suffix
SC260590	15 Gallon Container	12 x 18 x 24	GY, GN
SC260591	Swing Trash Lid	13 x 18 x 9	GY
SC260592	Bottle & Can Lid	13 x 18 x 9	GY, GN
SC260593	Paper Lid	13 x 18 x 9	GY, GN



GLOBAL[®] OUTDOOR STEEL RECYCLING RECEPTACLE



SC261800BL

Endures extreme climate conditions making them great for outdoor use. Features a rugged, long lasting flat bar steel body that deters graffiti and vandalism; three recycling logos on lid and a RECYCLE decal on body for clear identification. Metal band top for extra strength. Includes security cable, anchor kit and black rigid plastic liner. **Flat Lid or Rain Cap Lid available.** Powder coat finish in blue.

Model	Gal. Cap.	Dia." x H'	Lid
SC261800BL	36	28 x 36	Flat
SC261850BL	36	28 x 41 ³ / ₄	Rain Cap

PLASTIC RECYCLING TOTES



SC240772



SC240771

Offers high nesting ratios for low cost shipping. Durable impact resistant plastic features 35% post consumer content. Includes recycling decals on 2 sides and easy grip handles. Nests when empty and allows cross stacking. Base includes impact feet.

Model	Gal. Cap.	Size
SC240771	14	19 ³ / ₄ x 15 ³ / ₄ x 13 ¹ / ₂
SC240772	18	23 x 16 x 14 ¹ / ₂

GLOBAL[®] MOBILE WASTE CONTAINERS



RECESSED GRIP HANDLES FOR EASY LID OPENING



AXLE MOUNTED WHEELS

SC241077BL

Store and move trash or recycling waste with ease. Made using impact and corrosion resistant high density polyethylene. Reinforced at stress points for durability. Hinged, tight fitting lid contains odors and keeps out rain. Allows easy tilt and roll mobility using a grip handle and two axle-mounted wheels. **Specify Color Suffix: Gray (GY) or Blue (BL).**

Model	Gal.	W" x D" x H"	Color
SC241077	32	19 x 22 x 36	BL, GY



GLOBAL[®] HEAVY DUTY WASTE CONTAINER

AMAZING PRICE!



DOLLY FITS EASILY ON CONTAINER



EASY LIFTING HANDLE

The unbeatable, economic choice that won't compromise quality or durability. Made with durable, long lasting polyethylene resin. Leak-proof seamless plastic allows easy cleaning and won't corrode, chip or crack. Nests when empty to save valuable storage space. Rugged rolled formed top rim is reinforced for added strength. Strong grip handles make lifting easy. **Optional Lids** protect contents and help keep odors in. Lids allow receptacle stacking when in use. **Optional Dolly** simply twists on and off the base of 20, 32, 44 & 55 gallon waste containers to convert trash receptacles into easy-to-move containers. Dolly includes five 3" non marring swivel casters. NSF approved, OSHA listed.

Model	Description
SC240456GY	10 Gallon Container
SC240457GY	10 Gallon Flat Lid
SC240458GY	20 Gallon Container
SC240459GY	20 Gallon Flat Lid
SC240460GY	32 Gallon Container
SC240461GY	32 Gallon Flat Lid
SC240462GY	44 Gallon Container
SC240463GY	44 Gallon Flat Lid
SC240464GY	55 Gallon Container
SC240465GY	55 Gallon Flat Lid
SC240466BK	Dolly-Fits 20, 32, 44, 55

DOLLY
SC240466BK

80 More Products Available Online – chproducts.com

GLOBAL[®] PLASTIC FLIP TOP TRASH CONTAINER

LID
SC260596GY

15 Gallon Capacity

CONTAINER
SC260597GY



Corrosion resistant polypropylene. Includes built-in side grip handles for easy lifting. 15 gallon capacity; measures 18"W x 12"D x 24"H. Gray color only. **Flip Top Lid** (sold separately) helps keep contents out of sight.

CONTAINER
Model
SC260597GY

LID
Model
SC260596GY

STEEL STEP-ON WASTE CANS

Step-on receptacles are self closing for sanitary use and have tight fitting lids for odor control. Rugged steel construction. **Medical Step Cans** feature zinc-plated powder coat finish with plastic inner bin with carry handle. **Specify color suffix: White (WH), Red (RD) or Stainless Steel (SS).**



SC237752RD

MEDICAL STEP CANS

Model	Gallon Cap.	Dia." x H"	Color
SC237752WH	3 1/2	10" x 16	White
SC237752RD	3 1/2	10" x 16	Red
SC237752SS	3 1/2	10" x 16	Stainless

GLOBAL® PLASTIC WASTEBASKETS



SC261747BK

Ideal for a variety of applications ranging from classroom, office, commercial or institutional use. Includes rounded corners for extra strength. Durable plastic won't chip, rust or dent. Available in **Beige or Black. Add color suffix when ordering.**

Model	Qt. Cap.	Color Suffix
SC261747	13 ^{5/8}	BG, BK
SC261748	28 ^{1/8}	BG, BK
SC261749	41 ^{1/4}	BG, BK

WOODEN TRAY TOP RECEPTACLE



Industrial grade receptacle is designed to compliment office and commercial cafeteria settings and to endure heavy use. Constructed of 5/8" thick particle board with melamine finish. Open door to easily empty 36 gallon plastic liner (sold separately). Tray area measures 19"W x 18 1/4"D x 2 1/4"H. Push door features **Thank You** message.

Model	W" x D" x H"	Color
SC603589	20 1/2 x 19 x 44	Oak
SC237175	20 1/2 x 19 x 44	Gray
SC237141	36 Gallon Plastic Liner	Black

GLOBAL® TRASH CAN LINERS



Low Density Polyethylene liners are on coreless rolls and star sealed for maximum performance. Puncture and tear resistant. 100% recyclable. **Clear Liners** are USDA and FDA approved. **Black Liners** are made with minimum 85% recycled material including 10% post consumer recycled resins; Leeds Approved. **High Density Polyethylene** liners are an excellent choice for office and restroom paper products. Star sealed bottoms. USDA and FDA Approved. Ideal for commercial and industrial use only.

LOW DENSITY POLYETHYLENE

Model	W" x H"	Gal. Cap.	Gauge	Color	Case Count
SC261757	24x32	12-16	0.50 Mil	White	500
SC261758	30x36	20-30	0.70 Mil	White	200
SC261759	40x46	40-45	0.70 Mil	White	100
SC261760	38x58	55	0.70 Mil	White	100
SC261766	40x46	40-45	0.75 Mil	Clear	100
SC261770	38x58	55	0.75 Mil	Clear	100
SC261761	33x39	33	1.00 Mil	Black	100
SC261762	33x39	33	1.40 Mil	Black	100
SC261763	40x46	40-45	1.00 Mil	Black	100
SC261764	40x46	40-45	1.40 Mil	Black	100
SC261765	40x46	40-45	1.70 Mil	Black	100
SC261767	38x58	55	1.00 Mil	Black	100
SC261768	38x58	55	1.40 Mil	Black	100
SC261769	38x58	55	1.70 Mil	Black	100
SC261771	32x50	33	3.00 Mil	Black	50

HIGH DENSITY POLYETHYLENE

Model	W" x H"	Gal. Cap.	Gauge	Color	Case Count
SC261772	24x33	12-16	5.4 Mic	Natural	1000
SC261773	30x37	20-30	9 Mic	Natural	500
SC261774	33x40	33	14.4 Mic	Natural	250
SC261775	40x48	40-45	14 Mic	Natural	250
SC261776	38x60	55	14.4 Mic	Natural	200

OUTDOOR STEEL MESH RECEPTACLES

Expanded metal waste receptacles are attractive, durable and ADA compliant. Rugged expanded steel body is reinforced with circular bands, vertical ribs and curled edging for extra strength and support. Endures extreme climate conditions to make them great for outdoor use. Perfect for parks, universities, apartment and office complexes and city streets. Choice of **Galvanized or Black Powder Coat Finish.**



Model	Gal. Cap.	Dia." x H"	Color	SC237633
SC237633	48	23 x 33	Galvanized	
SC237634BK	48	23 x 33	Black	

OUTDOOR SLATTED STEEL RECEPTACLES

Feature a rugged, long lasting flat bar steel body that deters graffiti and vandalism. Metal band top for extra strength. These cans endure extreme climate conditions making them ideal for outdoor use. Lid with large 7" diameter opening for easy waste disposal. Includes an anchor kit and black plastic liner. Powder coat finish. Choose between **Flat Lid** or **Rain Cap Lid** that prevents rain, snow and unwanted debris from entering container. **Specify Color Suffix: Black (BK) or Green (GN).**



Model	Gal. Cap.	Dia." x H"	Lid
SC237725	24	23 x 36	Flat
SC237726	36	28 x 36	Flat
SC260803	24	23 x 41 3/4	Rain Cap
SC260804	36	28 x 41 3/4	Rain Cap



SC237726BK

OUTDOOR ASHTRAY



Our most popular outdoor ashtray gets even better! The flame retardant polyethylene housing keeps out rain and airflow to extinguish butts and fight odor. Exclusive stainless steel ash plate keeps urn looking fresh and clean. Unique design helps extinguish butts. Restricted opening keeps out non-cigarette waste. Includes tie-down eye to secure receptacle. **Add color suffix: BEIGE (BG), Black (BK), Green (GN), Gray (GY) or Terracotta (RG).**

Available In 5 Colors

Model	Color	Dia." x H"	Gallon Cap.
SC261391	BG, BK, GY, RG	11 x 30	1
SC245133	BG, BK GN, GY, RG	15 x 39	6
SC238151	Security Cable Kit includes cable and padlock (3 keys)		



ALUMINUM OUTDOOR ASHTRAY



RUST-PROOF ALUMINUM BODY

SILVER
BLACK



ANTI THEFT SECURITY CABLE



WEATHER RESISTANT INTERLOCKING TOP WITH REMOVABLE CONTAINER

Aluminum **Butt-Tainer** keeps grounds clean and butt-free. Interlocking top with removable steel container for easy emptying. Large 10" diameter base with provisions for mounting and tie down lugs to prevent theft. Moisture protective design keeps rain out and prevents waste smells. 29" High. **Add color suffix: Silver (SL) or Black (BK).**

Model	Dia." x H"	
SC603028	10 x 29	
SC238152	Security Cable Kit Includes cable, padlock (3 keys)	

WALL MOUNT OUTDOOR ASHTRAY



Weather and fire resistant 20 gauge stainless steel. The 215 cu. inch inner receptacle holds over 700 butts and is easy to empty. 9"W x 5"D x 13"H.

Model **SC238068**



STONE PANEL ASH/TRASH RECEPTACLE

Withstands extreme weather conditions and long-term daily use with a fire safe and attractive stone finish. Stone panels provide a maintenance and vandalism free finish. Top removes easily for emptying. Includes leak-proof, fire resistant removable galvanized steel liner with handles. Heavy steel frame construction provides stability. Includes fixed height feet for anchoring. Choose the **Lift-off Sand Urn Top** or the **Weather Urn**. Weather urn conceals cigarette waste and features a piano hinge lid for easy cigarette butt disposal. Ships assembled. Sand sold separately. **Specify color suffix: Brown Frame with Brown Stone (BN) or Gray Frame with Gray Stone (GY).**

Model	Gal. Cap.	Top	H" x Sq."
SC238242	2 1/2	Trash/Sand Urn	24 x 10 1/4
SC238240	2 1/2	Trash/Sand Urn w/Weather Top	28 x 10 1/4
SC239577	12	Trash/Sand Urn	32 x 13 1/2
SC239576	12	Trash/Sand Urn w/Weather Top	35 x 13 1/2
SC238243	24	Trash/Sand Urn	32 x 17 1/2
SC238241	24	Trash/Sand Urn w/Weather Top	36 x 17 1/2



UNIVERSAL SPREADER

Ideal for spreading ice melt, salt, seed, fertilizer, lime and similar materials. Spreader features a welded steel frame and large 100 lb. capacity plastic hopper with screen that helps prevent materials from jamming. Comfort grip handle with flow regulator for ease of use. Large 13" pneumatic tires make pushing through slush, ice, and grass easy. The 3-flap adjustable deflector controls spread pattern, while the rear deflector protects the operator's feet. Includes plastic cover to protect materials from the elements. Blue color finish. Easy assembly.



100 LB. CAPACITY

SC640788



COATED GRANULAR ICE MELT

Coated Granular Ice Melt is a blend of rock salt coated with liquid deicer. It is quick and effective and less corrosive than standard rock salts. Biodegradable formula is safer for grass and plants. Spreads evenly. Non-staining. Continues to work to -20°F. Coated Granular Ice Melt with Slip Grip adds liquid calcium chloride infused traction granules to melt ice and snow while also providing grip and traction. Traction granules crush to dust for less cleanup.



SC640831

Model	Description	Cap.
SC640831	Coated Granular Ice Melt	40 Lbs.
SC640832	Coated Granular Ice Melt with Slip Grip	40 Lbs.



WINTER TOOLS

Model	Type	Blade Width	Blade Material	Handle Material
SCB599512	Combo	18"	Poly	Poly
SCB363079	Combo	18"	Poly	Wood
SCB501232	Ice Scraper	7"	Steel	Wood
SCB363074	Snow Pusher	30"	Poly	Wood
SCB363076	Snow Pusher	26"	Poly	Aluminum
SCB599516	Roof Rake	24"	Poly	Aluminum



MOP BUCKETS WITH WRINGER COMBO

Corrosion resistant yellow polypropylene. Mop bucket offers a 9 1/2 gallon capacity. Moves easily on non-marring 3" diameter swivel casters. Available with Side Press or Down Press wringer. Wringers feature a comfort grip handle. Sentiment screens trap dirty residue to keep the mop and water clean longer. Mop capacity is 32 oz. Down Press offers more efficient water removal from mop.



Model	Side/Down Pressure
SC260594	Side
SC260595	Down

SC260595

SC260594



WET FLOOR CAUTION SIGNS



SC261725

SC261726

Constructed of a durable polypropylene and feature yellow background color with black letters and ANSI compliant graphics. Easily fold to 1" thick for convenient storage or transport on janitor carts. Choose between an English or Multi-Lingual message in English, French and Spanish.

Model	Description
SC261725	English
SC261726	Multi-Lingual

SC261835



SC261836

SC261837

Jaws Mate plastic jaws firmly clamp mop heads. Twist action secures mop head in place. Recommended for 5" wide headband mops.

Quick Change plastic head and wheel clamp firmly holds mops in place. Hinged side gate allows quick and easy mop changes.

Grip style steel head uses spring action to secure any size mop. The stirrup opens wide, allowing to change soiled mops without the need to touch.

Style	Size	Material	Model
Jaws Mate	1" x 60"	Fiberglass	SC261835
Quick Change	1" x 60"	Fiberglass	SC261836
Grip	1 1/8" x 60"	Wood	SC261837

Mop heads are durable and provide superior performance. Compatible with all Global mop handles (Sold Separately). Mop Heads are Sold Individually. Add Suffix: **Narrow Band (N)** or **Wide Band (W)**.

A & B. Looped-end mop heads are constructed from cotton/rayon synthetic blend for less unraveling, linting and increased floor coverage. **Style B** is Blue Blend. For institutional and food service industry.

C. Cut-end mop heads are constructed from cotton, 4-ply yarn, and natural color. For all purpose scrubbing and cleaning.

D. Finishing looped-end mop heads are made of a tight twist poly blended yarn, White/Blue color. Specifically intended for applying floor finishes. Narrow band only.

Style	Size	Model
A	Medium	SC261826
A	Large	SC261827
B	Small	SC261828
B	Medium	SC261829
B	Large	SC261830
C	16 oz.	SC261831
C	24 oz.	SC261832
D	Medium	SC261833
D	Large	SC261834



MOP HEADS AND HANDLES

01-800-467-0529

chproductos.com

83



HAND SOAP & SANITIZERS



LUXURY
FOAM HAND
SOAP
SC640801

Model	Description	Capacity	Color	Pkg. Qty.
DISPENSERS				
SC640805	Manual Dispenser	1250 ml	Black	1
SC640806	Manual Dispenser	1250 ml	White/Gray	1
SC640807	Automatic Dispenser	1250 ml	Black	1
SC640808	Automatic Dispenser	1250 ml	White/Gray	1

Model	Description	Capacity	Pkg. Qty.
SOAP & SANITIZERS			
SC640801	Luxury Foam Hand Soap	1250 ml	6
SC640802	Antibacterial Foam Hand Soap	1250 ml	6
SC640803	Instant Foam Hand Sanitizer	1200 ml	6
SC640804	Instant Foam Alcohol Free Hand Sanitizer	1250 ml	6

Model	Description	Dispenser Type	Color	Pkg. Qty.
STARTER KITS- ONE DISPENSER/ 6 REFILLS				
SC640809	Luxury Foam Hand Soap Kit	Manual	Black	1
SC640810	Luxury Foam Hand Soap Kit	Manual	White/Gray	1
SC640811	Luxury Foam Hand Soap Kit	Automatic	Black	1
SC640812	Luxury Foam Hand Soap Kit	Automatic	White/Gray	1
SC640813	Instant Foam Hand Sanitizer Kit	Manual	Black	1
SC640814	Instant Foam Hand Sanitizer Kit	Manual	White/Gray	1
SC640815	Instant Foam Hand Sanitizer Kit	Automatic	Black	1
SC640816	Instant Foam Hand Sanitizer Kit	Automatic	White/Gray	1



MANUAL DISPENSER
SCB640805



AUTOMATIC DISPENSER
SCB640808

Global® Hand Soaps & Sanitizers help kill germs, and are ideal for use in offices, schools, warehouses, food service, and more. Global® Manual & Automatic Dispensers are constructed of durable plastic with large site windows for easy refill. Includes easy-to-slide product identification window cards. Top dispensing technology reduces risk of leaking valves. High 1250mL capacities help reduce maintenance. Global® Hand Soaps feature rich, soft foam formulations with pleasant scents that quickly clean away light to medium soils. Contains Aloe and Vitamin E to help nourish the skin. Global® Hand Sanitizer is effective and convenient to sanitize hands when soap and water are not available. Fast-acting alcohol and alcohol-free formulas kill 99.9% of common germs within 15 seconds. All Global® hand soap and sanitizers are for use with Global® manual and automatic dispensers only.

POWERFUL GLOBAL® CLEANING CHEMICALS

**SAVE UP TO 62%
VERSUS
NATIONAL BRANDS**



**Economical &
Easy to Use
Cleaning
Solutions**

For Global® Cleaning Kits Visit
globalindustrial.com

Global cleaning chemicals are ideal for a variety of cleaning and maintenance applications in offices, schools, warehouses, hotels and more. **Floor Cleaners** offer solutions for buffing, stripping, and cleaning and deodorizing resilient tile, terrazzo, and more. **General Purpose Cleaners and De-greasers** cut through dirt, grease, oil, grime, ink, and food soils. **Liquid Drain Opener** dissolves and removes grease, hair, food, and other organic materials from drains and grease traps. **Bathroom Cleaners** are designed to clean,

deodorize and remove stains from toilet bowls, urinals, partitions and floors. **Foam and Liquid Hand Soaps** offer a rich lather that leaves skin clean and refreshed. **Glass and Mirror Cleaner** offers streak-free, non-ammoniated cleaning that will not scratch or haze surfaces. **Multi-Purpose Cleaner and Protectant** removes dirt, oil, smears and smudges, and adds a shine to hard surfaces including metal.

Model	Description	Size	Case Qty.
Floor Cleaners			
SC64043	Ultra High Speed Floor Finish	Gallon Bottle	4/1 Gallon
SC64044	Floor Cleaner & Deodorizer	Gallon Bottle	4/1 Gallon
SC64045	Super Concentrated Floor Stripper	Quart Bottle	6/1 Quart
General Purpose Cleaners & De-greasers			
SC64046	Heavy Duty Cleaner & De-greaser	Gallon Bottle	4/1 Gallon
SC64047	Multi-Purpose Cleaner & De-greaser	Gallon Bottle	4/1 Gallon
Drain Opener			
SC64048	Liquid Drain Opener	Quart Bottle	12/1 Quart

Model	Description	Size	Case Qty.
Bathroom Cleaners			
SC64049	Clinging Bowl Cleaner	Quart Bottle	12/1 Quart
SC64040	Bacterial Enzyme Odor Eliminator	Quart Bottle	6/1 Quart
Hand Soap			
SC64041	Foam Hand Soap	Gallon Bottle	4/1 Gallon
SC64042	Liquid Hand Soap	Gallon Bottle	4/1 Gallon
Glass & Mirror Cleaner			
SC64043	Glass & Mirror Cleaner	Quart Bottle	12/1 Quart
SC64044	Glass & Mirror Cleaner	Gallon Bottle	4/1 Gallon
Metal Cleaner			
SC64045	Multi-Purpose Cleaner & Protectant	Quart Bottle	6/1 Quart

AUTOMATIC SCRUBBERS

Electric Scrubbers - Model SC261122

- Rotationally molded polyethylene housing
- 18" Cleaning Path/Deck
- 8 gal. solution/ 11 gal. recovery tanks
- 28"W cast aluminum squeegee assembly
- 1 HP, 2-stage motor that offers 65" water lift
- 250 RPM, 66 lbs. of pad pressure
- Coverage rate of 18,000 sq. ft. per hour
- 82'L power cord

SC261122



ACCESSORIES

Model	Description
PAD* Case of 5 SC261169	17" Floor Pad

*Specify color suffix for pad type:
Green Scrubbing (GN), Red Buffing (RD)

REPLACEMENT PARTS

Model	Description
SC261127	18" Pad Driver
SC261180	18" Front Squeegee Blade
SC261181	18" Rear Squeegee Blade

Auto Battery Scrubbers

- 20" Scrubbers provides 21,000 sq. ft. per hour coverage
- Two 12V batteries. **SC261123** is 105 amp with 3 hr. run time and **SC261124** is 130 amp with 4 hr. run time per charge. **SC261125** is 215 amp with 5 hr. run time
- 26" Scrubber offers variable speed control with 3-stage motor. Provides 26,000 sq. ft. per hour coverage. Includes two 215 amp batteries for 4 1/2 hr. run time per charge
- Includes on-board charger and set of replacement squeegee blades

SC261123



ACCESSORIES

Model	Description
PAD* Case of 5 SC261163†	13" Floor Pad
SC261170	20" Floor Pad
(†Model SC261126 Requires 2)	

* Specify color suffix for pad type:
Green Scrubbing (GN), Red Buffing (RD)

REPLACEMENT PARTS

Model	Description
SC261128	13" Pad Driver (Req. 2)
SC261129	20" Pad Driver
SC261182	20" Front Squeegee Blade
SC261183	20" Rear Squeegee Blade
SC261184	26" Front Squeegee Blade
SC261185	26" Rear Squeegee Blade

Online Video & Photos



SC261126

Model	Cleaning Path/Deck"	Pad Pressure Lbs.	Squeegee Width"	Water Lift"	Tank Cap. Gal. Solution/Recovery
SC261123	20	50	28	55	13/15
SC261124	20	50	28	55	13/15
SC261125	20	Up to 200	28	55	16/16
SC261126	26	Up to 150	32	67	17/17

18 GALLON WET & DRY VACUUM

Front-mount 24" squeegee assembly is great for wet pick-up, while included tools allow dry clean-up. Made using rotationally molded polyethylene housing. 24"W cleaning path. 10" stair climbing wheels. On-board tool storage includes crevice tool, dusting brush, 3-piece stainless steel wand, wet & dry pick-up tools and 9'L vacuum hose. 2-stage, 1.17 HP motor offers 95 CFM and 110" water lift. 50'L safety yellow power cord. 110V, 5 Year Motor; 12 Year Housing Limited Warranty.



Model	Description
SC261750	18 Gal. Wet/Dry Vac
SC261751	Optional 30" squeegee

FLOOR MACHINES

- All metal construction
- Low speed for use on wet hard floors and carpets
- Heavy duty 1.5HP motor
- Triple planetary, all steel gear box
- Safety lock-out switch with easy thumb control throttle
- Pad driver included
- 50'L safety yellow power cord
- **SC261117 & SC261118** have dual capacitor motor
- **SC261119** has DC rectified motor

SC261118

Shown with Floor Pad

Model	Cleaning Path/Deck"	Speed
SC261117	17	175 rpm
SC261118	20	175 rpm
SC261119	20	185-330 rpm

ACCESSORIES

Model	Description
Pad* Case of 5 SC261164	17" Floor Pad
SC261165	20" Floor Pad
Solution Tank SC261130	2.5 Gallon

*Specify color suffix for pad type: Black Stripping (BK), Green Scrubbing (GN), Purple Heavy Duty Stripping (PL), Red Buffing (RD), White Polishing (WH).



FLOOR BURNISHERS

- High speed operation for use on dry floors only
- Heavy duty 1.5HP DC rectified motor
- Handle mounted circuit breaker
- Safety lock-out switch with easy thumb control
- 50'L safety yellow power cord
- Tilt and roll mobility with rear wheels
- **SC261121** features folding handle and passive dust control with cloth collector bag

SC261121



Online Video & Photos

Model	Speed
SC261120	1500 rpm
SC261121	2000 rpm
BURNISHER PAD - Case of 5 SC261166	High Freq., Soft To Med. Finish
SC261167	Low Freq., Med. To Hard Finish
SC261168	Low Freq., Hard Finish

SC261120



HIGH VELOCITY HAND DRYERS



INFRARED SENSOR FOR TOUCH-FREE OPERATION



Ideal for public restrooms in schools, offices, theaters and more. Dries hands in 15 seconds or less with 60-second auto shutoff. Features an adjustable infrared sensor for sanitary touch-free operation. Constructed of durable stainless steel with satin finish. 110-120V, 500W operation. GREENSPEC® approved.

Model	Description	Color Finish
SC640305	High Velocity Hand Dryer - Stainless Cover	Stainless
SC640800	High Velocity Hand Dryer - Steel Cover	White



SC269902TN

JANITORIAL CABINET



RECESSED LOCKING HANDLE

Organizes maintenance and cleaning supplies. Provides storage for brooms, mops, vacuum cleaners and more. Locking handle for safety and security. Box formed, channel reinforced doors for added strength. Retaining lip on bottom level contains spills.

Model	W" x D" x H"	Color Suffix	Type
SC269902	36 x 18 x 72	BK, GY, TN	Unassembled
SC269903	36 x 18 x 72	BK, GY, TN	Assembled



SC442972

INDUSTRIAL PUSH SWEEPER

- 32" cleaning path covers 17,000 square feet per hour for maximum productivity
- Only 30 lbs. and easy to maneuver
- Height adjustment allows for cleaning on various terrains
- Quadra Brush System for efficient dust and debris containment
- 9 gallon hopper empties easy
- Durable polyethylene body with tubular steel fold up handle



SC606693

ROLLING STEP STOOL

Spring loaded casters permit rolling and retract to allow base to hug the floor for stability. Over 17" top step height with top step diameter of 11 1/2". Durable steel construction with non-slip surface steps. 10 Year Limited Warranty.

500 lb. capacity!



SC261031



3/4 HP FLOOR DRYER

Injection molded housing and fan assembly for quiet operation. **3/4 HP, 3-speed motor provides up to 2,455 CFM** for superior floor drying capability. 3 height adjustments for optimum drying. Built-in handle for easy lifting. Includes 20'L power cord. 16"W x 18"D x 17"H. 120V/60Hz. ETL approved.



GLOBAL LOBBY BROOM & DUST PAN

Lobby Broom is cut and shaped for easy sweeping under tables, fixtures and hard to reach areas. Flagged polypropylene fill bristles that pick up fine dirt particles. **Upright Dust Pan** features a quiet hinge pin design, durable and ergonomic. Wear pads and wheels on the back extend product life. Built-in-handle on back lets you empty without touching pan. 13"W x 4"H bin opening. Combo Kit includes one upright dust pan and one lobby broom.

Description	Dimension	Pkg. Qty.	Model
Lobby Broom	8 x 1 x 36	6	SC261728
Upright Dust Pan	13 x 11 x 37	6	SC261727
Broom/Dust Pan Combo Kit			SC261790

FOLD-DOWN MAINTENANCE PLATFORM



Folds down in seconds for compact storage; side rails, gate and safety screen stores within the 5 1/2"D base, with 16" overall height. Includes a 37" x 37" slip resistant checker floor plate and a 60" expanded metal screen that protects operator from forklift masts. 42"H handrails with mid-rail and locking gate secures operator on platform. For added protection, safety lock and chain are included for secure forklift attachment. 3/8" x 7/8" fork pockets are 26" on center.

Steel with durable high visibility yellow powder coat finish. Includes four 5" swivel casters, 2 locking.



660 lb. Capacity

Model	Description
SC309225	Fold Down Maintenance Platform
SC237232	Fluorescent Bulb caddy



CHAIN HOIST

Drop forge steel swivel hook with safety latch. Hardened steel load chain for long life. Lubrication free load brake offers positive load control. Tempered molybdenum steel gears. Lightweight and ideal for low ceiling applications.



Model	Cap. Lbs.	Head-Room"	Wt. Lbs.
10' LIFT			
SC241638	2000	12	23
SC241639	4000	15	31
SC241640	6000	18 1/2	50
SC241641	10000	23 1/2	82
20' LIFT			
SC241642	2000	12	36
SC241643	4000	15	50
SC241644	6000	18 1/2	77
SC241645	10000	23 1/2	118

"I" BEAM TROLLEY

Adjustable to fit width of beam. Self-aligning frame and ball bearing wheels. Usable on straight or curved track.

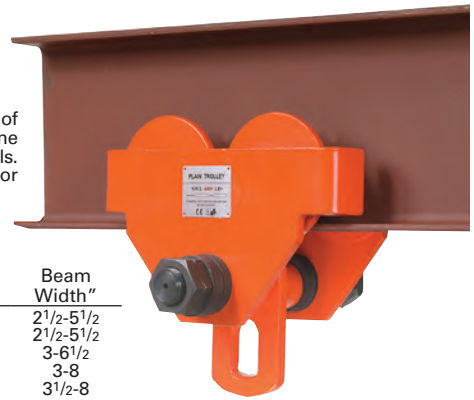

Model	Cap. Lbs.	Beam Width"
SC241646	1000	2 1/2-5 1/2
SC241647	2000	2 1/2-5 1/2
SC241648	4000	3-6 1/2
SC241649	6000	3-8
SC241650	10000	3 1/2-8



Heavy duty steel construction with welded safety heel restraint. Fork extensions affect truck capacity. Refer to your lift truck manufacturer for a derated capacity. 2" maximum fork thickness. Durable powder coat finish.

NOTE: OSHA requires contacting the manufacturer of your truck for written approval for the use of any fork truck attachments.

NOTE: OSHA regulations state that the length of fork extensions may not exceed fork length by more than 50%

FORK EXTENSION *Extend Reach 50%*

Extension width is 1 1/8" greater than fork width.

Model	Extension L"	Fork W"
SC774102	60	4
SC774106	72	4
SC774110	60	5
SC774114	72	5
SC774122	72	6
SC241679	96	5

Other sizes can be made to order; specify length, width and thickness of fork that will be used. Call for more information

PORTABLE EXPANDABLE CONVEYOR 175 lb. capacity per foot



RETRACTS TO 6'2" TO SAVE SPACE

Expands From 6'2" to 24'8"

Instantly set-up conveyor lines for shipping, receiving, assembly and packaging areas. Flexible, portable gravity conveyor expands from 6'2" to 24'8". Rugged 5/16" steel axles and self-tracking skate wheels with enclosed steel ball bearing offers smooth material flow. 175 lbs. per foot capacity. 1 1/4" (compressed) to 4" (expanded) axle centers for 7" minimum package size. Seven zinc

plated telescopic legs with 4" thermoplastic rubber swivel casters adjust independently from 31 3/4" to 40 1/2" H to achieve maximum gravity flow and create banked curves. All units bend around a 27" radius. End legs have locking brakes. Includes convenient box-stop and hook couplers to connect additional conveyors. Simply insert legs into integral sockets and conveyor is ready to use.

Order optional Swing Stick for "dockless" receiving. Eases unloading/ loading of truck. 5' long with 2" dia. steel wheels and 4" axle centers. Attaches easily with included hardware and folds atop conveyor when not in use.

Model	W"
SC168114	18
SC168115	24

W"	Wheels Per Axle	NYLON WHEELS	STEEL WHEELS
		Model	Model
18	6	SC168110	SC168112
24	8	SC168111	SC168113



**5000 lb.
capacity**



SC501920

PALLET GRABBER

Pull loaded pallets and slide heavy crates to edge of dock or truck. Variable jaw width grabs pallet securely and automatically releases. 3.3" maximum jaw opening, primarily used for center stringer pulling.

Model
SC132600

PULLING CHAIN - 1/4" dia. with Hook on both ends.

Model	Length'	Cap. Lbs.
SC501920	20	1250
SC501922	40	1250

HIGH TRACTION ALUMINUM DOCK PLATE

HIGH VISIBILITY
SAFETY YELLOW

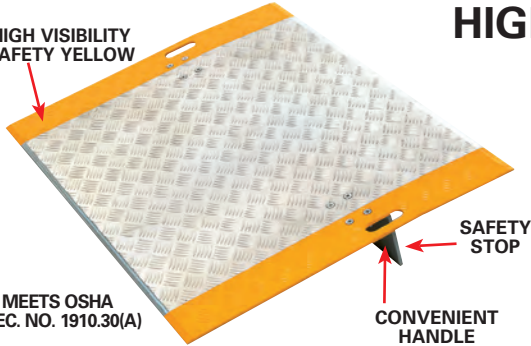

MEETS OSHA
SPEC. NO. 1910.30(A)



Diamond tread surface provides more traction points per square foot than competitor's surface. Lightweight 3/8" thick aluminum withstands heavy traffic but lifts easily using hand-holds. The 11" apron with beveled edges and an 11° crown provide smooth, efficient entry and exit. Bottom includes a bolted safety stop to keep plate in position. **Note** that width should be 12" wider than load. Not for use with rider type trucks.

Model	W"x L"	Ht.**	Cap. Lbs.	Wt. Lbs.
SC241742	36 x 24	1	3350	35
SC241743	36 x 36	3	2000	46
SC241744	48 x 24	1	3700	51
SC241745	48 x 36	3	2700	66
SC241746	48 x 48	5	2050	86
SC241747	60 x 48	5	2660	100

*Height is the difference above or below dock.

A "Must" for Safely Loading and Unloading Trailers



TRAILER STABILIZING JACK

A. ECONOMY MODEL. 50,000 li. static capacity, 5,000 li. lifting capacity. Twin handles angled for fast, easy 44"-51" height adjustment. 5" x 5" top plate. 14" diameter base plate for stability. Includes convenient carrying handle.

Model SC500001

B. STANDARD MODEL. 100,000 li. static capacity, 40,000 li. lifting capacity. Removable pipe handle for quick 39 1/2"-51" height adjustment with ratcheting screw mechanism. Permits worker to stay upright while operating, acts as steering lever. 14" base provides maximum rigidity. 7 3/4" top cap. Accommodates up to 9° tilt-off level. Heavy duty 8" solid rubber transport wheels.

Model SC132050

C. HEAVY DUTY MODEL. 100,000 li. static capacity, 50,000 li. lifting capacity. Adjusts from 39 1/2"-51" high with ratcheting screw mechanism. Features easy-to-use two-way reversible hand ratchet with sure-grip handle. Hand truck design permits quick-and-easy positioning. Large 24"L x 6"W beam for sure trailer stability. 16" triangular base. (2) 8" diameter solid rubber wheels and (1) 4" diameter steel wheel.

Model SC500106

SURE GRIP WHEEL CHOCK

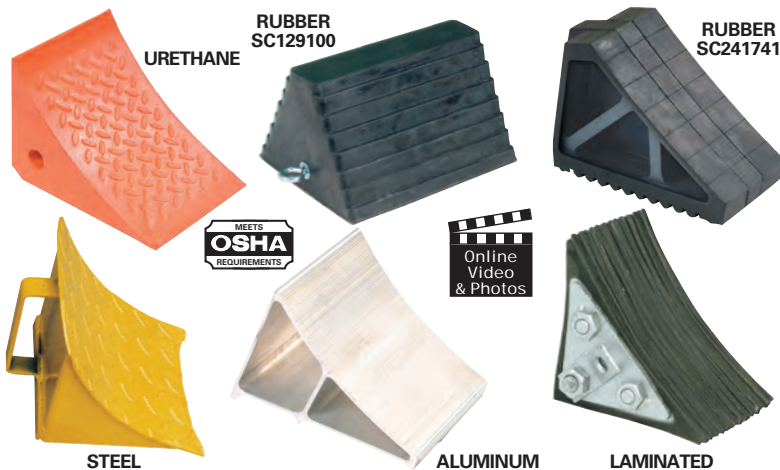

Chock trailers, off-highway construction equipment, buses, jets and other heavily loaded vehicles...helps protect against runaway vehicle accidents. Built-in traction grippers create maximum friction between tire and parking surface.

RUBBER - 10 1/2" L x 4 1/2" W x 7" H. Model SC241741

RUBBER - 10" L x 8" W x 6" H. Model SC129100

URETHANE - 11" L x 8" W x 8" H. Model SC117100

STEEL - 7 1/2" L x 7 1/2" W x 8 1/2" H. Model SC241965

LAMINATED RUBBER - 8" L x 8" W x 8" H. Model SC955070

ALUMINUM - 10 3/4" L x 7" W x 8" H. Model SC133108

SECURITY CHAIN helps prevent chocks from being stolen. 10' long chain with attaching ring. Model SC500050

ENERGY SAVING STRIP DOOR

Installs in 30 Minutes Based on 8' x 8' opening

FASTEST INSTALLATION OF ANY STRIP DOOR ON THE MARKET.
EXCLUSIVE GLASS FILLED POLYPROPYLENE MOUNTING BRACKET REDUCES INSTALLATION TIME BY 90%. PRE-PUNCHED STRIPS SIMPLY HOOK ON AND WILL NOT ACCIDENTALLY COME OFF.

- Permits non-stop movement of all plant traffic; 2-way visibility • **12"W x .125" thick strips** have 66% overlap (4" each side) to reduce A/C, heat loss; reduces noise, dust, fumes, drafts • Heavy duty flexible vinyl has outstanding clarity and warp-resistance • Round edge strips with concave/convex overlap improves seal, eliminates dangerous sharp protrusions • Effective thermal barrier and provides excellent temperature resistance from -10°F to 150°F • Special UV stabilizers help reduce fading or yellowing
- Safety orange end panel strips • Fire-resistant, as well as self-extinguishing, and registered as such by the California state Fire Marshal's office.

SCRATCH-RESISTANT STRIP DOOR. Ribbed on both sides to help reduce scratches and abrasions to the strips. Strips retain clarity for lasting visibility and increased service life. Overlapping strips interlock to help provide a tighter, more energy efficient seal. Ideal for heavy traffic applications.

NOTE: For surface mounted installation, order strip door one foot wider and higher than door opening.

RECESSED MOUNTED
(Under Header)

SURFACE MOUNTED
(On Wall)



FLEXIBLE TRANSPARENT
12" WIDE x 1/8" THICK
SCRATCH-RESISTANT STRIPS

HIGHLY VISIBLE SAFETY ORANGE END PANELS

PEDESTRIAN DOOR

8"W x .080" thick strips have 50% overlap (2" each side). Ideal for passageways or outdoor entrances where temperature, noise or dust control is required.



PEDESTRIAN DOOR Door Opening

Model	W' x H'
SC786146	3 x 7
SC786147	4 x 7
SC786148	5 x 7
SC786149	6 x 7
SC786150	3 x 8
SC786151	4 x 8
SC786152	5 x 8
SC786153	6 x 8
SC786154	7 x 8
SC786155	8 x 8

Door Opening W' x H'	STANDARD DOOR	SCRATCH RESISTANT DOOR	Door Opening W' x H'	STANDARD DOOR	SCRATCH RESISTANT DOOR
	Model	Model		Model	Model
6 x 7	SC786001	SC786103	6 x 10	SC786011	SC786124
7 x 7	SC786156	SC786104	7 x 10	SC786167	SC786125
8 x 7	SC786002	SC786105	8 x 10	SC786012	SC786126
9 x 7	SC786157	SC786106	9 x 10	SC786168	SC786127
10 x 7	SC786003	SC786107	10 x 10	SC786013	SC786128
12 x 7	SC786004	SC786108	12 x 10	SC786014	SC786129
14 x 7	SC786005	SC786109	14 x 10	SC786015	SC786130
6 x 8	SC786006	SC786110	6 x 12	SC786016	SC786131
7 x 8	SC786158	SC786111	7 x 12	SC786169	SC786132
8 x 8	SC786007	SC786112	8 x 12	SC786017	SC786133
9 x 8	SC786159	SC786113	9 x 12	SC786170	SC786134
10 x 8	SC786008	SC786114	10 x 12	SC786018	SC786135
12 x 8	SC786009	SC786115	12 x 12	SC786019	SC786136
14 x 8	SC786010	SC786116	14 x 12	SC786020	SC786137
6 x 9	SC786160	SC786117	6 x 13	SC786021	SC786138
7 x 9	SC786161	SC786118	7 x 13	SC786171	SC786139
8 x 9	SC786162	SC786119	8 x 13	SC786022	SC786140
9 x 9	SC786163	SC786120	9 x 13	SC786172	SC786141
10 x 9	SC786164	SC786121	10 x 13	SC786023	SC786142
12 x 9	SC786165	SC786122	12 x 13	SC786024	SC786143
14 x 9	SC786166	SC786123	14 x 13	SC786025	SC786144

HEAVY DUTY DOCK BUMPER

Tough plies of fabric impregnated rubber pads are compressed and secured by 3/4" thick steel rods and mounted to 1/4" thick angle iron brackets. **Absorbs over 80% of impact force.** Pre-drilled 13/16" anchor bolt holes offer quick installation. Allow 12" between each bumper for dependable protection.



Model	Overall W" * x D" x H"
SC988026	12 x 4 1/2 x 10
SC988027	18 x 4 1/2 x 10
SC988028	24 x 4 1/2 x 10
SC988029	36 x 4 1/2 x 10
SC988030	11 x 4 1/2 x 20
SC988031	11 x 4 1/2 x 24

* Width is center-to-center of bolt holes

SC988026

STRIP DOOR ACCESSORIES

REPLACEMENT STRIP
W' x H' Model

12"W x 1/8" THICK	Model
12 x 7	SC504077
12 x 8	SC504078
12 x 9	SC504079
12 x 10	SC504080
12 x 12	SC504081
12 x 13	SC504082

SCRATCH RESISTANT STRIP
12"W x 1/8" THICK

Model	
12 x 7	SC504083
12 x 8	SC504084
12 x 9	SC504085
12 x 10	SC504086
12 x 12	SC504087
12 x 13	SC504088

PEDESTRIAN DOOR STRIP
8"W x .080" THICK

Model	
8 x 7	SC504089
8 x 8	SC504090

STANDARD MOUNTING BRACKET. Durable glass filled polypropylene. Add or cut to length as needed.

Model	Length'
SC585346	4
SC585347	6
SC585348	8

DELUXE MOUNTING BRACKET. Heavy duty .090" thick aluminum bracket will not rust or corrode. Patented design offers quick install and locks strips in place. Pre-drilled and ready to mount. Add or cut to length as needed. Limited Lifetime Warranty.

Model	Length'
SC241824	1
SC241825	2
SC241826	3
SC241827	4

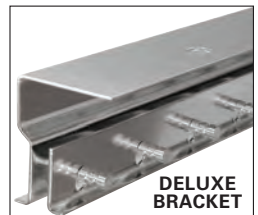

DELUXE BRACKET

FOLDING SECURITY GATE

Protect Against Pilferage and Unauthorized Entry



Constructed of strong 3/4" 14 gauge steel channel. Exclusive design protects the durable gray powder coat finish from scratching when folded for a longer life. Assembled with non-corroding zinc-plated rivets. Includes smooth rolling wheel and padlock lug. Double Gates have a cane bolt that holds left half in position and both halves open fully. **Gates fold completely and swing 180°** for unobstructed access. Gates can be either recess or surface mounted. Easy to install.

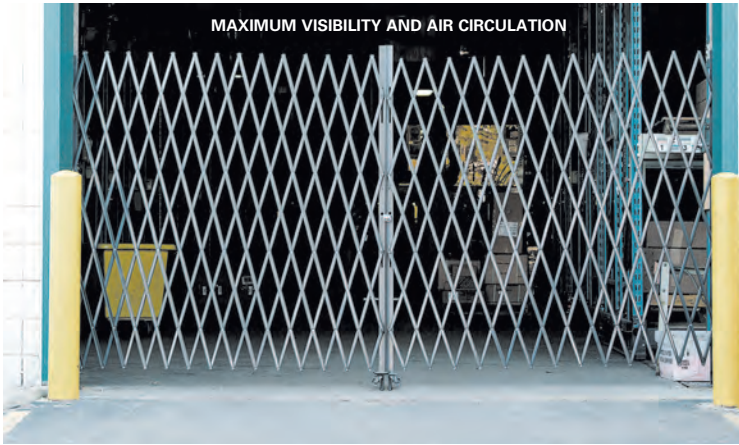

Model	W' x H**	Width" Retracted
SINGLE FOLDING GATE		
SC968130	5 1/2 x 5	10
SC968132	5 1/2 x 6 1/2	12 1/2
SC968136	5 1/2 x 8	14
SC968138	6 1/2 x 6 1/2	13
SC968142	6 1/2 x 8	15
SC968144	7 1/2 x 6 1/2	14 1/2
SC968148	7 1/2 x 8	18
DOUBLE FOLDING GATE		
SC968100	8 x 6 1/2	12 1/2
SC968102	8 x 8	14
SC241689	10 x 5	10
SC968104	10 x 6 1/2	12 1/2
SC968106	10 x 8	14
SC968108	12 x 6 1/2	13
SC968110	12 x 8	15
SC968116	16 x 6 1/2	14 1/2
SC968118	16 x 8	18
	Retracted Height	
SC959101D	Keyed Padlock	



MACHINERY GUARD



RACK GUARD



REMOVABLE CAP

BASE FOR EXISTING CONCRETE

BASE FOR UNDERGROUND



INDOOR/OUTDOOR SAFETY GUARDS AND BOLLARDS

Configured in 3 styles to protect various equipment and machinery in warehouses and parking and loading areas. Safety yellow powder coat finish with black visibility stripes. Mounting kit sold separately. **Bolt-On Models** are made with all welded 4 1/2" diameter steel. Base plates measure 8" x 8". **Removable Base Models** feature a detachable base plate that allows quick, easy and temporary removal. Made from 5 1/2" diameter steel tubing. Base plates measure 12 1/4" x 12 1/4". All **Removable Base Bollards** feature a removable rubber cap that allows bollard to be filled with concrete for extra reinforcement. **Removable Cap Bollards** with Chain Slots connect to other bollards using an optional Steel Chain to create a barrier. Made with 5 1/2" diameter tubular steel and are available in 2 styles: **Existing Concrete Bollards (Suffix M)** allow floor anchoring and **Underground Bollards (Suffix G)** install in fresh, wet cement.

	BOLT ON Model	REMOVABLE BASE Model	REMOVABLE CAP Model
STEEL BOLLARD			
24"H	SC337326R	SC238794	SC652898
36"H	SC337327R	SC238795	SC652899
42"H	SC337328R	SC238796	SC652900
RACK GUARD			
9 x 36	SC337320R	SC238802	
9 x 48	SC337321R	SC238803	
MACHINERY GUARD			
24 x 36	SC337322R	SC238806	
24 x 48	SC337323R	SC238807	
36 x 48	SC337324R	SC443480	
48 x 48	SC337325R	SC443481	
42 x 36	---	SC238810*	
42 x 48	---	SC238811*	
Concrete Mounting Kit (includes 4 bolts)			SC442198
Keyed Padlock with 2 Keys			SC269322
10 Foot Steel Chain			SC269500

*Models do not feature padlockable base



OVERHEAD DOOR TRACK PROTECTOR

Protect delicate overhead door tracks from forklift, cargo or vehicle damage with this heavy duty steel guard. The 6" x 6" base plate has a 3" x 3" notch out to accommodate track, includes mounting holes and requires only 3 bolts (sold separately) for easy installation. Safety yellow powder coat finish.

Model	Height"
SC652894	24
SC652895	36
SC652896	48
SC652901	Concrete Installation Kit Includes 4 bolts

CORNER GUARDS



Fits snug around corners to protect machinery, buildings and offices. Heavy duty welded steel with yellow powder coat finish and 3"W black stripes. Constructed of 4" schedule 10 steel pipe with 4 1/2" outer diameter. Base plates measure 8" x 8" and allow floor anchoring.

Model	Overall H"	L"
SC239799	24	24
SC239800	36	24
SC239801	42	24
SC239802	24	30
SC239803	36	30
SC239804	42	30
SC442196	Concrete Mounting Kit	

PROTECTIVE RAIL BARRIER

Highly visible safety yellow finish. Welded base plates measure 10" sq. x 5/8" thick and are pre-drilled for easy installation. Assembly hardware included. Choose **18"H Post** to support a single rail or **42"H Post** to support a double rail barrier system. Steel **Posts** measure 4" sq. x 1/4" thick. **Rails** are made with ribbed 10 gauge high-tensile steel. **Bracket Kit** includes 2 drop-in style brackets that attach to posts to allow rail sections to slide onto brackets for installation. Purchase **Concrete Mounting Kit** to mount base plate to floor.

Model	Description
SC436724	4'L Rail
SC436725	5'L Rail
SC436726	6'L Rail
SC436728	8'L Rail
SC436730	10'L Rail
SC436731	18"H Post-Single Rail
SC436732	42"H Post-Double Rail
SC436733	Bracket Kit (pair) For Drop-in Style
SC442197	Concrete Mounting Kit



BRACKET KIT



SLIDE RAIL ONTO BRACKET



PEDESTRIAN BARRIER

Ideal for directing personnel or traffic flow. Heavy duty 1 5/8" diameter 42" high steel pipe frame with mid-rail for rigidity. For permanent installations order single or double sockets to form a straight row or angles up to 30 degrees to create a curved barricade. Use free standing base with or without casters for portability.



Model	Description
SC940370	36"L Barrier
SC940371	48"L Barrier
SC940372	72"L Barrier
SC940373	96"L Barrier
SC940374	Single Socket
SC940375	Double Socket
SC940377	Base w/casters
SC940378	Base w/feet
SC940379	Concrete Anchor Bolts (Set of 4) 3/8" x 3"



CROWD CONTROL BARRIER



COUPLERS JOIN BARRIERS FOR EXTENDED BARRICADE

Direct pedestrians with these all-welded steel barriers. Easy to transport, they also include removable feet that allow flat stacking and storage. Sections include couplers that join units in runs of any length. Measure 102"L x 40"H each with 5/4" spaces in between vertical bars.

Model	Rail Dia."	Description
SC652833	1 1/4	Galvanized
SC652835	1 1/4	Powder Coat Safety Yellow
SC695008	1 5/8	Galvanized Heavy-Duty
SC695009	1 5/8	Powder Coat Safety Yellow Heavy-Duty

SAFETY BARRICADE GATE



SIX SWIVEL CASTERS, 4 WITH BRAKES



SECURITY CHAIN PREVENTS UNAUTHORIZED USE

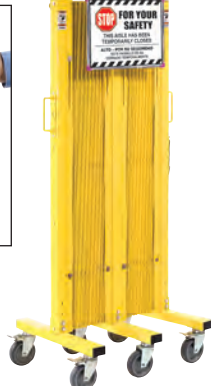

FOLDS TO COMPACT 23 1/2" L



Online Video & Photos

Quickly and easily block access to dangerous or restricted areas with this industrial grade gate that weighs a generous 154 lbs. All steel construction with powder coat finish. Gate expands to 20'L x 52 1/2"H and folds to a compact 23 1/2"L x 24"W x 64"H. Moves easily on 6 heavy duty casters (4 braking, 2 swivel). Includes warning sign shown.



SC652923

Expands to 20 Ft.

CROWD CONTROL



Create lines and block off restricted areas in banks, offices, retail environments and more. Self retracting 6 1/2" L belt helps direct lines and crowds to or away from desired areas. Locking belt receivers included to prevent accidental belt release. Capped belt ends prevent nylon belts from raveling. **Steel Post** is made using 1 1/8" diameter weighted base for stability. Measures 39"H overall. Available in Stainless Steel or Black powder coat finish. Easy assembly. **Specify Belt Color Suffix: Black (BK), Red (RD), Blue (BL) or Black & Yellow Stripe (YB).** Note: Blue Belt available for Steel Post only.

Model	Description	Belt Length'
SC695010	Black Steel Post with Belt	7 1/2
SC269383	Polished Stainless Steel Post with Belt	6 1/2
SC269387	Black Wall Mount with Belt and Receiver	6 1/2
SC269545	Merchandising Bowl with Adapter	

BLACK SIGN WITH ADAPTER		7" x 11"	11" x 14"
Model	Description		
SC443082	2 Sides "Please Enter Here"	SC443081	SC443084
	2 Sides "Exit"	SC443082	SC443085
	1 Side "Please Enter Here"	SC443083	SC443086
	Sign Frame w/Clear Acrylic	SC239324	SC239325

INDOOR/OUTDOOR PEDESTRIAN CONTROL

Keep aisles clear from moving traffic and secure sensitive areas. 41"H x 2" diameter. **Plastic Post** is available with portable 14" diameter base or ground stake. Fill base with sand for stability. Heavy-duty 1 1/2" **plastic link chain** hooks easily to post; choose white or alternating black and yellow links. Use one post for every 8 ft. of area secured. Plastic Post sold 6 per carton.

Post Style	WHITE	YELLOW
Portable Base	SC822002W	SC822022Y
Ground Stake	SC822003W	SC822003Y

50' LINK CHAIN	
SC954112W	White
SC954112Y	Yellow/Black



CROWD CONTROL POST & ROPES

Post accepts **Ropes** (sold separately) to create effective and easy to use portable crowd control barriers. Easy to set-up and move where you need them. 34"H post is made using a 10 1/4" diameter weighted base for stability. Stainless steel post has a gold plated finish. Die cast, zinc alloy hanger accepts **Rope Belts** (sold separately). Belts are 59"L and include gold plated stainless steel ends for easy connection to post. Rope is available in plush, stain resistant **Velour** or leather-like **Braided Vinyl**. Easy assembly. **Specify Rope Color Suffix: Blue (BL), Red (RD) or Black (BK).**

Model	Description
SC269384	34"H Gold Finished Stainless Steel Post
SC269385	59"L Velour Rope with Ends
SC269386	59"L Braided Vinyl Rope with Ends



SPEED BUMP AND CABLE PROTECTOR

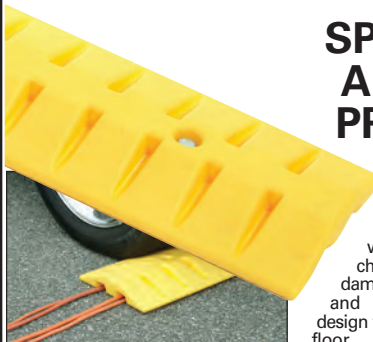

Versatile design handles the heaviest of vehicle loads while also acting as a dual channel protector. Prevents damage to air lines, water lines, and electrical cable. Flexible design fits contour of road or factory floor. High-density polyethylene construction with non-skid surface

resists weather, UV and chemical damage. High visibility yellow. Anchor bolts included. 72"L x 10"W x 2"H. Cable channel dimension: 1 1/4"W x 7/8"H.

Model	Wt. Lbs.
SC506847	15

STENCILS



HANDICAP PARKING STENCIL Heavy-duty black vinyl is reusable. **Meets ADA requirements.** 37" x 43".

STENCIL KIT includes 9"H A to Z and 0 to 9, extra large NO PARKING, VISITOR, IN and OUT and arrow symbol.

Model
SC505199

Model
SC219400

TRAFFIC CONTROL SIGNS

Reflective signs in .080 reflective aluminum with pre-drilled holes for easy mounting.

Model	Description	Size"
SC652645	STOP	24 x 24



HARDWARE. 2 1/2" galvanized nut, bolt, washer set. SC954256

Save When You Buy Any

PARKING LOT SIGNS



SC932136



SC649151

Impact and corrosion resistant .063" aluminum signs are finished in glossy baked enamel. Pre-drilled for easy mounting. Add "H" suffix for heavy duty reflective .080 mil version.

GRID BIKE RACKS



SC652773

Riveted grid design secures bicycles in upright position. Powder coated galvanized, industrial grade steel withstands years of outdoor use. Framing uses 1 1/2" dia. tubular steel; grids are 3/4" dia. steel. Double-sided accommodates bikes on either side. 3 anchor styles: Cement for use in fresh concrete or asphalt, Earth for soil and lawns or 6" Spikes for permanent mounting in existing pavement. Easy assembly.

Model	Description
SC652770	5-Bike Single
SC652771	9-Bike Single
SC652772	10-Bike Double
SC652773	18-Bike Double
SC652774	Anchor-Cement / 4pk.
SC652775	Anchor-Earth / 4pk.
SC652776	Anchor-6" Spike / 4pk.

WAVE BIKE RACKS



SC652778MBK

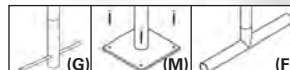

Wave design eliminates sharp edges for safety and allows double sided bike attachment to secure bikes in upright position. Made using rugged 1 1/2" tubular steel with polyester powder coat finish that withstands the elements. Choose from 3 available mounting types. **Below**

Model	Description	L"
SC442804	2-Bike Wave	14 1/2
SC652777	5-Bike Wave	41
SC652778	7-Bike Wave	68
SC652779	9-Bike Wave	94

STADIUM BIKE RACKS

U-rail bike rails allow double sided bike storage. Black powder coat finish. **Easy Assembly** racks are made using 1 1/2" diameter x .098 thick tubular steel. U-rails easily attach to U-channel base rails for assembly. Base rails allow freestanding, portable use or can be anchored (mounting hardware not included). **Heavy Duty Racks** are made of 2 3/8" diameter x 9 gauge schedule 40 pipe for strength that lasts. Heavyweight, freestanding steel to eliminate need for anchoring.



SC269319

Model	L" x D" x H"	Rail Spacing"	Wt. lbs.	Model	Model	L" x D" x H"	Rail Spacing"	Wt. lbs.	Model
EASY ASSEMBLY				HEAVY DUTY ALL-WELDED					
6-Bike	74 x 15 x 35	34 3/8	66	SC269319	6-Bike	98 3/4 x 21 x 37 1/4	46	154	SC442812
8-Bike	110 x 15 x 35	34 3/8	94	SC269320	8-Bike	110 x 21 x 37 1/4	46	190	SC442813

KD BIKE RACK

The KD Bike Rack is constructed with durable steel and features an epoxy powder coat finish. Secures up to (3) big and (3) small bikes. 3 Anchor styles: **Cement** for new pavement, **Earth** for soil and lawns or **6" Spikes** for existing pavement. Easy assembly and withstands years of outdoor use.



Model	Description
SC436501	6-Bike Single KD Rack
SC652774	Anchor-Cement / 4 pk.
SC652775	Anchor - Earth / 4 pk.
SC652776	Anchor - 6" Spike / 4 pk.

CHROME TRIPLE GLOVE BOX HOLDER

Glove box holder provides a convenient, simple storage solution for examination rooms. Chrome steel for long lasting durability. Wall mounted. Measures 11 15/16" W x 3 13/16" D x 14 9/16" H overall.



Model	Color
SC436802	Chrome

MEDICINE CABINETS

Provide a convenient storage area for first aid supplies, prescription drugs and other pharmaceutical supplies. Cabinets are made using cold rolled steel with white powder coat finish. Pull-out shelf provides a convenient work area. 3 fixed interior shelves are welded into place. Cabinet is lockable using cylinder lock and 2 keys. Available in **Solid Metal** or **Plexiglass** models. Color White.



Door Type	W" x D" x H"	Handle	Model
Solid Metal	18 x 8 x 27	Pull Handle	SC269940

OFFICE DEHUMIDIFIERS



SCB653556



Energy Star Units with easy access and remote controller. Mobile, 24 hour on/off timer. Plastic construction. Model **SC653556** has a built-in pump. 120 volt. 6' power cord. 1 Year Limited Warranty.

Brand	Pints/Day	W" x D" x H"	Model
Global	30	12 x 9 x 20	SC653550
Global	50	16 x 11 x 32	SC653552
Global	70	16 x 11 x 23	SC653555
Global	70	16 x 11 x 23	SC653556

OSCILLATING DELUXE 1/2 HP PEDESTAL FAN

This 30" diameter industrial fan features a heavy-duty base and a hand screw knob for easy, tool free height adjustments. Rugged 3-speed, 10000/8750/7300 CFM, 1/2 HP ball bearing motor uses PSC technology. Height adjustable from 60"- 81"H. Oscillating motion distributes airflow in a 90° sweep or allows fixed fan positioning. Pivot-action fan head allows tilt angle adjustments. Steel wire guards safely enclose 3 metal blades that are precision balanced for optimum performance. "Y" suffix Model offers a safety yellow powder coat finish on the guard and pedestal. 18'L cord with 3-prong plug. 120V. UL listed. 3 Year Limited Warranty.

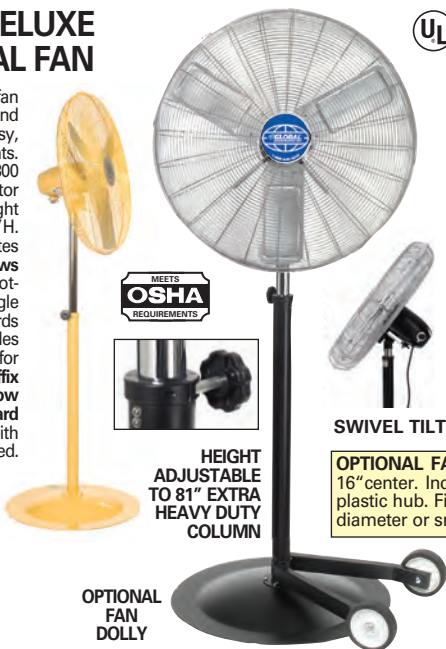

SWIVEL TILT

HEIGHT ADJUSTABLE TO 81" EXTRA HEAVY DUTY COLUMN

OPTIONAL FAN DOLLY 1" x 2" 18 gauge tubular steel on 16" center. Includes 2- 6" x 1 1/2" rubber wheels with bolt-on plastic hub. Fits 1 1/2" to 2 1/4" dia. pedestal columns with 28" diameter or smaller base. Model SC245658

OPTIONAL FAN DOLLY



Model
SC652299
SC652299Y

OSCILLATING INDUSTRIAL PEDESTAL FAN

24" diameter fan features a 1/4 HP motor which provides up to 7,525 CFM. Has a 24" diameter pedestal base. 30" diameter fan features a 1/3 HP motor which provides up to 8,775 CFM. Has a 27" diameter pedestal base. Fans feature 3-speed motor and 3 precision balanced metal fan blades. Oscillating motion distributes airflow in a 90° sweep or allows fixed fan positioning. Pivot action fan head allows vertical airflow adjustments. Tool free, hand screw fan height adjustments possible. Wire guards safely enclose metal blades. Includes an 18'L power cord with a 3-conductor, 120V plug; no need for extension cord. Meets OSHA standards, UL listed. 1 Year Limited Warranty.



SWIVEL TILT

HEIGHT ADJUSTABLE FROM 56" TO 65"



Dia."	Model
24	SC585279
30	SC585280



OSCILLATING DELUXE 1/2 HP WALL FAN

24" and 30" diameter fans mount to the wall for safe, out of the way operation. Both fans feature a Heavy Duty 1/2HP, 3-speed motor which uses PSC type ball bearing technology and is permanently lubricated for long life. Fans are configured for either fixed positioning or 90° oscillation by using a safety clutch mechanism. 3 precision balanced blades are enclosed in steel wire guards for safety. Pivot action fan head allows tilt angle adjustments. Assembly contents include wall bracket, angle support bracket with right and left supports. Also includes pull chain control and 12'L, 3-conductor, 120V power cord. UL listed. 3 Year Limited Warranty. 24" diameter fan provides up to 8,650 CFM. 30" diameter fan provides up to 10,000 CFM.



Dia."	HP	Model
24	1/2	SC258321
30	1/2	SC258322

OSCILLATING INDUSTRIAL WALL FAN

24" and 30" diameter fans mount to the wall for safe, out of the way operation. 24" diameter fans feature a 1/4HP motor and provide a max of 7,525 CFM and 30" diameter fans feature a 1/3HP motor and provide a max of 8,775 CFM. Both motors are 3-speed and are permanently lubricated for long life. Fans are configured for either fixed positioning or 90° oscillation by using a safety clutch mechanism. 3 precision balanced blades are enclosed in steel wire guards for safety. Pivot action fan head allows tilt angle adjustments. Assembly contents include wall bracket, angle support bracket with right and left supports. Also includes pull chain control and 12'L, 3-conductor, 120V power cord. UL listed. 1 Year Limited Warranty.



Dia."	HP	Model
24	1/4	SC607050
30	1/3	SC607051

INDUSTRIAL BLOWER FANS



SC600554



SC607220



24" MODEL TILTS 360°



SC258320



These industrial fans feature a quiet 2-speed motor with thermal cutoff for overheat protection. Blower fans have a roller bearing motor that is heat resistant and maintenance-free. The sturdy steel housing of these drum fans have formed channels for enhanced rigidity and a black powder coat finish. These portable fans include a grip handle for easy transport. Grills have curved grid supports. Fans include an 18'L 3-conductor power cord with plug. 120V. Direct Drive 24" & 36" diameter fans feature 3 blades and a pivot mount that allows blower tilt to direct airflow. 24" diameter fan tightens in place with a hand screw knob and include 5" rubber wheels. 36" diameter fan is enclosed in wire safety guards with a tubular steel pivot-action stand allowing 360° swivel for tilt angle airflow adjustments. 2 - 6" axle-mounted wheels provide mobility. Belt Driven 42" & 48" diameter fans have 4 balanced blades and 7" solid rubber wheels. Meets OSHA standards, UL listed. 1 Year Limited Warranty.

Dia."	Drive Type	HP	CFM High	Amps.	H" x D"	Model
24	Direct	1/3	8,575	2	30 1/2 x 13 1/4	SC607220
36	Direct	2/3	13,000	4.2	42 x 24	SC258320
42	Belt	1	17,600	6.5	45 1/2 x 16 1/2	SC600554
48	Belt	1	15,200	5.8	52 x 16 1/2	SC600555

BEST VALUE AIR CURTAIN



SC246608



Maintains indoor air quality and saves energy by minimizing heated and air conditioned air loss through open doorways. Powerful airflow prevents dust, odors, fumes, flying insects and outside air from entering indoors. Features 2-speed fan operation. Can be easily mounted above or next to doors using included hardware. 120V, UL listed. Replacement remote available online, Model **SC292339**.



SC292339

INCLUDES AN EASY TO USE REMOTE CONTROL.

W"	CFM	Amps	Model
36	815	2.85	SC246608
48	990	3.5	SC246609
60	1,280	4.8	SC246610

EVAPORATIVE COOLERS



These evaporative coolers utilize efficient housing that is designed to produce effective cooling in highly humid conditions. Portable evaporative coolers help increase worker productivity by creating a more comfortable working environment. One-piece, corrosion resistant molded plastic housing with built-in water tank. Water is supplied to internal tank using a standard 3/4" hose (not included). Energy efficient motor and submersible pump assembly. **SC246560BK** and **SC245881BK** models have a centrifugal air system that eliminates the need for fan blades and reduces noise. These models also come in Brown.



SC600543

For Additional Models Visit globalindustrial.com

Manufacturer	Blade Size"	CFM HP	Tank Cap. Gal.	Drive Type	Cooling Sq. Ft.	Model
Global	20	3/8	3,531	15. Direct Drive	538	SC600580
Global	30	3/4	10,595	15. Direct Drive	2,691	SC600543
Global	36	1	5,300	32. Direct Drive	3,229	SC600581



OUTDOOR PEDESTAL & WALL FANS WITH MISTING

Optional Misting Kit Available!

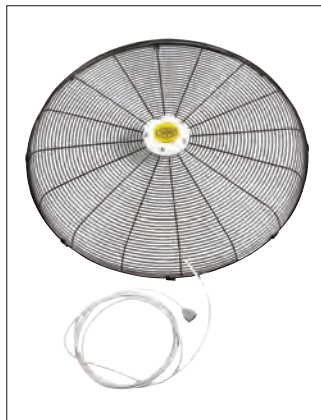

Global's Industrial Outdoor Oscillating Pedestal and wall Fans with misting kit have a 3-speed industrial motor powering three precision balanced Steel fan blades. Pedestal fan is height adjustable from 58"-65"H. Fans come with 10' x 18AWG Cord with GFCI Plug. Black Powder Coat Finish, rated for outdoor use. Front Fan Grille with Misting feature mounts easily. UL Listed.



Fan Type	Dia"	OUTDOOR FAN		FAN WITH MISTING KIT
		Model	Model	Model
Pedestal	24	SC292448	SC292454	SC292454
Pedestal	30	SC292449	SC292455	SC292455
Wall	24	SC292450	SC292456	SC292456
Wall	30	SC292451	SC292457	SC292457

INDUSTRIAL WALL & PEDESTAL FANS



WALL MOUNT

Fans include an open air over ball bearing single-phase motor and 3 quiet aluminum blades that are enclosed in chrome wire guards. Pivot-action fan head allows vertical tilt angle adjustments. 2-speed pull chain operation. 12'L SJT type, 3-conductor power cord. 120V. Easy assembly with pre-assembled fan heads and mounts. Meets OSHA standards, UL listed. **Pedestal Fans** allow tool free fan height adjustments. Includes 27" diameter base. **Wall Mount Fans** include a wall bracket with swing-action arm for side-to-side placement.

REPLACEMENT MOUNTS

Fan Type	Model
Wall Non-Oscillating	SC246545
Wall Oscillating	SC246544
Pedestal Non-Oscillating	SC246543
Pedestal Oscillating	SC246542



Dia"	HP	CFM		Brand	WALL		PEDESTAL	
		High	Low		Model	Brand	Model	
25	1/4	5,400	4,300	CD	SC246578	CD	SC246586	
25	1/3	7,000	5,200	CD	SC246579	CD	SC246587	
25	1/2	8,600	7,100	CD	SC246580	CD	SC246588	
30	1/4	6,000	4,800	CD	SC246581	CD	SC246589	
30	1/3	8,200	6,200	CD	SC246582	CD	SC246590	
30	1/4	7,900	6,000	CD	SC246585	CD	SC246593	



WINDOW & WALL AIR CONDITIONERS



SC246540



For Optional Wall Sleeves & Grilles Visit globalindustrial.com



SC246536

The lightweight, compact design of **window air conditioners** fit in most windows to provide efficient cooling. Window ACs feature digital temperature display, auto-restart, timer mode, remote controls and filters that slide out easily for cleaning. Some models have electric heat for year-round temperature control. **Through-the-wall air conditioners** feature digital displays that show set temperature, sleep mode and a remote control for ease of operation. Installation kits included. Air conditioner BTU's range from 5K-28K. See website for additional models.

WALL Brand	Cooling Sq.Ft.	BTU		Volts	EER	Model	Wall Sleeve Model
		Cool	Heat				
Global	350	8,000	----	115	9.4	SC246540	SC600501
Global	550	12,000	----	115	9.4	SC246541	SC600501

WINDOW Brand	Cooling Sq.Ft.	BTU		Volts	EER	Model
		Cool	Heat			
Global	350	8,000	----	115	10.8	SC292458
Global	550	12,000	----	115	10.8	SC240111
Global	1,050	18,500	16,000	208/230	9.7	SC246538
Global	1,400	25,000	16,000	208/230	9.4	SC292460



SC292253



CEILING FAN

Ceiling Fans cool in the summer and move stagnant air during heating season. Metal construction with aluminum blades finished in white epoxy. All models are 115V and contain a permanently lubricated, sealed ball bearing motor for long life and provisions for hardwire. 16" down rods provide safety clearance from ceiling as well as interior safety cables for secure positioning. **Model SC246496** includes aluminum blades and 5 speed fan controller. **Model SC653548** includes 4 speed wall mount control. Canarm's optional Variable speed switches help control multiple fans, **models SC653107 and SC653108** (sold separately).

Brand	Dia."	CFM High	Amps	Warranty		Model
				Years		
Global	56	20,500	0.5	1		SC246496
Canarm	56	20,500	0.9	5		SC653104
Canarm	56	27,500	0.83	5		SC653105
Global	60	42,500	0.61	1		SC653548
Canarm	60	46,000	0.84	5		SC653106
J & D	60	43,500	0.74	Lifetime		SCB735658

EXHAUST FANS WITH SHUTTER



SC294497



TPI and CD Exhaust Fan with Shutter feature a 120V 1-phase totally enclosed permanently lubricated direct drive motor with provisions for hardwired installation. These shutter mounted fans install on inside wall and eliminate the need for external framing. Aluminum blades are enclosed in a sturdy steel spiral wire guard. Note: Rough-in hole size is 1/2" larger than fan blade size. **Multiple Speed Exhaust Fans** come with pull chain. Meets OSHA standards. UL listed. 1 Year Limited Warranty.

Brand	Dia."	HP	CFM High	Speeds		Model
				High	Speeds	
TPI	16	1/8	2,100	3		SC248450
CD	18	1/8	1,976	3		SC246619
CD	18	1/8	2,300	1		SC294496
CD	18	1/8	2,300	3		SC294496A
TPI	20	1/4	2,925	2		SC248451
CD	24	1/4	3,400	1		SC29449
CD	24	1/4	3,400	2		SC294497A
CD	30	1/4	3,950	1		SC294498
CD	30	1/4	3,950	2		SC294498A

INDUSTRIAL PORTABLE AIR CONDITIONERS

Industrial Portable Air Conditioners provide reliable and economical spot cooling in a variety of professional and residential environments including industrial plants, server rooms, hospitals and offices, and especially where electrical equipment creates a heat load. Cooling range from 400-4,000 sq. ft. **Kwikool** Air Cooled Air Conditioners bring in air from an outside source to cool its condenser, cycling hot air to an outside source. **Kwikool Water Cooled Air Conditioners** are unique because the units eliminate the need for vents and ducting but require access to a circulating water system. Tap water should not be used. All units come with a 1 Year Limited Warranty. **All Global Industrial Air Conditioners** Are Air Cooled and Portable. Global model **SC292256** comes with a heat pump for heating as well as cooling. All units come with a 1 Year Limited Warranty. Optional Ceiling Kits sold separately, 12" model **SC292311**, 16" model **SC292322**. Package of two 5" Cold Air Nozzles are required and included with all Global models except **SC292256** which does not use nozzles.

Brand	System	Tons	BTU	Cooling		CFM			Model
				Sq. Ft.	Speeds	High	Amps	Volts	
Global	Air	1.2	13,600	440	2	440	13	115	SC292253
Global	Air	1.5	16,800	600	2	460	17	115	SC292254
Global	Air	2	23,500	800	2	460	12.6	230	SC292255
Global	Air/Heat Pump	1.5	16,800/18,500	600	2	460	16	115	SC292256

FLOOR FANS



Floor fans feature a permanently lubricated 3-Speed, 120V sleeve bearing motor. Portable floor fans include 3 aluminum fan blades enclosed in steel wire guards. Fan head pivots 360° for tilt angle adjustments. Global Models include a 7'L cord. Portable Stand models feature steel wire guards with a welded carry handle that acts as a cord wrap. TPI Models include a 10'L SJT type 3-conductor cord, epoxy coated black steel frame, comfort grip handles and 2 wheels for mobility. Meets OSHA requirements, UL listed. 1 Year Limited Warranty.



Fan Style	Brand	Blade Dia."	HP	CFM			Model
				High	Med.	Low	
A	Global	12	1/12	2,030	1,400	1,190	SC258323
A	Global	18	1/8	4,550	3,675	2,800	SC258324
A	TPI	24	1/8	6,350	5,200	3,600	SC606680



VENTILATOR & EXHAUST FANS



Ventilate and cool manholes, tanks and crawl spaces. Lightweight and portable with an easy-carry handle. Rubber feet on base to minimize noise and reduce vibrations. **Style A Steel Blower** has steel housing with powder coated steel wire safety guards. Includes 10'L power cord. **Plastic with Ducting** easily converts blower to an exhaust fan with convenient, flexible ducting. Quick-connect coupling for easy attachment and canister for storage. Horsepower rating based upon maximum speed/load. 1 Year Limited Warranty.

Style	Dia."	CFM	Duct L'	HP	Model	Style	Dia."	CFM	Duct L'	HP	Model
A	8	1,589	—	1/8	SC246340	A	12	2,931	—	3/8	SC246343
A	8	1,589	16	1/8	SC246429	A	12	2,931	16	3/8	SC246431
A	8	1,589	32	1/8	SC246430	A	12	2,931	32	3/8	SC246432

PTAC HEATING & COOLING

PTACs & Accessories are made of heavy duty plastic construction for long lasting durability. The models listed below feature both **heating and cooling capabilities for enhanced versatility**. Optional remote thermostat offers customized control for greater dependability. Sound reduction package ensures quiet operation. Corrosion-resistant fin coating extends operation life for increased reliability. Restart feature automatically resumes operation at previous settings when power is restored for ease of use. Smart Self-Check provides diagnostic points for correction of fault conditions. Uses R410A refrigerant for increased efficiency. Available in a variety of styles. Area coverage, BTUs and energy efficiency ratings vary per model. Meets EPA requirements. 1 Year Full/5 Year Sealed System Limited Warranty.



SC600499



SHOWN WITH SLEEVE,
SOLD SEPARATELY

Brand	BTU				Model	OPTIONAL	
	Cool	Heat	EER	Volts		WALL SLEEVE	WALL GRILLE
Global	9000	8100	11.3	230/265	SC292463	SC600502	SC600503
Global	12000	10800	10.5	230/265	SC292464	SC600502	SC600503
Global	14700	13500	9.6	230/265	SC292467	SC600502	SC600503

PORTABLE AIR CONDITIONERS

Portable Air Conditioners Are Designed For Safe And Energy Efficient Cooling Operation.

Portable Air Conditioners have a sturdy construction for long lasting durability and strength. Ideal for use in homes, offices, garages, shops and more. Provides reliable cooling for increased comfort. Choose from models with different operational modes, including **Cooling, Heating, Fan and Dehumidifier** for increased versatility. Cooling coverages range from 350 Sq. Ft. to 700 Sq. Ft. and cooling BTUs range from 8000 to 14,000. Dimensions vary per model.

Brand	Cooling		Cool	Heat	EER	Model
	Sq. Ft.	BTU				
Global	350	8,000	---	---	8.9	SC600506
Global	700	14,000	11,000	---	8.9	SC246535



SC600506



For Additional Models Visit
globalindustrial.com



SC246535

FORK MOUNTED DRUM GRAB

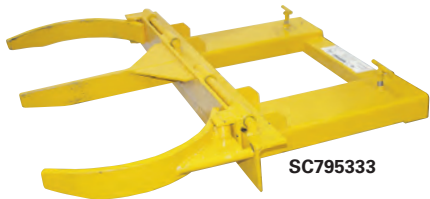

SC795333

**1500 lb.
capacity**

Lift, transport and deposit drums without leaving the seat of the fork truck. Grab mounts easily on the forks with hand tightened lock screws, no tools required. The knuckle gripping system is lowered around the drum, gripped tightly, and then lifted. The weight of the drum holds grab jaws in place to minimize slippage. Drum is automatically released by lowering the forks. Welded steel construction. **Hinged folding arm design** to save storage space. Powder coat yellow finish.

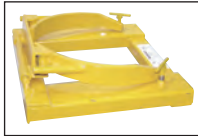

SC795332

Model	Description	Drum Gallon	Cap Lbs.	Fork Pockets W" x D" x OC"
SC795332	Single Steel	55	1500	5 1/4 x 2 x 16
SC795333	Double Steel	55	3000	7 1/4 x 2 1/4 x 24

HEAVY DUTY DRUM CRADLE



**1000 lb.
capacity**

5" WHEELS

3" SWIVEL CASTERS

Lift, move, drain and store 30 or 55 gallon steel drums quickly and easily. Sturdy, steel construction with hardwood retractable handle. Built-in rollers allow rotation of drum. Steel handle holds drum during tipping operation. Assembles easily.

Model	Wheels
SC482132	Polyolefin
SC482130	Steel

DRUM DUMPER

*Use Your Forklift as a Drum Handler...
Raise, Tilt and Drain Drums Easily*

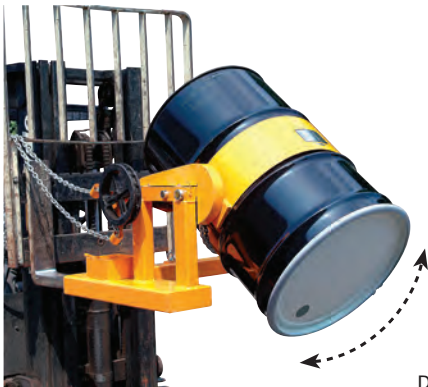

360° REMOTE CHAIN TILT CONTROL

Raise, tilt and drain 55 gallon steel drums easily without leaving forklift; pouring is controlled with 10' pull chain. Attaches quickly to forks. Fork pockets are 7"W x 2 1/2"H x 26 5/8"D, spaced 24 1/2" apart (39" O.A.).

Description	Model
800LB. CAP. (500LB. TILTING HALF FULL DRUM CAPACITY)	
55 Gallon Dumper	SC191700
1500LB. CAP. (500LB. TILTING HALF FULL DRUM CAPACITY)	
55 Gallon Dumper	SC190702

LOW COST DRUM CRADLE

**600 lb.
capacity**



SC233581

SC233572

Quickly move and drain 55 gallon steel drums. One man loading. Heavy gauge steel, retractable handle.

INDUSTRY STANDARD CRADLE

2 1/2" non-sparking polyolefin wheels for easy mobility. Assembles easily. Model SC233572

EASY STEER CRADLE

5" polyolefin load wheels, 3" polyolefin swivel casters for maximum maneuverability. Assembles easily. Model SC233581

HEAVY DUTY DRUM DOLLY

Wheel Them - Don't Carry Them!



STEEL



PLASTIC



STAINLESS STEEL

Increase usage of your drums. Drum dolly increases portability, allowing drums to be taken to and from work areas with ease. Move up to 55 gallon metal, fiber and plastic drums and containers. Rugged 3" casters provide maximum stability and easy maneuverability.

STEEL DOLLY

Model	Dia."	Drum Size	Wheels	Cap Lbs.
SC233886	19 1/2	30 Gallon	Rubber	600
SC233884	19 1/2	30 Gallon	Steel	1000
SC233882	24	55 Gallon	Rubber	600
SC233880	24	55 Gallon	Steel	1000

PLASTIC DOLLY

SC498820	24 1/4	30 & 55 Gallon	Rubber	900
----------	--------	----------------	--------	-----

STAINLESS STEEL DOLLY

SC233881	19	30 Gallon	Rubber	800
SC233883	24	55 Gallon	Rubber	800

MOBILE DRUM CARRIER

Raise, transport, rotate, agitate, tilt, and drain fully loaded drums. Self-supporting, transports drum upright to avoid spills. Automatic handle-locks prevent unintentional lowering. Tilt locks used to keep upright or horizontal to dispense. Unlock for manual tipping to any angle or end-over-end tumbling to agitate. Two 8" polyurethane load bearing wheels and 4" swivel caster for optimal maneuverability.

Model	Drum Type	Drum Dia."
SC952800	55 Gal. Steel	22 1/2"

800 lb. capacity



SC952800



DRUM PALLETIZER

Moves and transports drums easily to or from pallets with a maximum height of 8". Dual ratchet stops hold the weight of the drum, and provide several positions where the handle stays until operator takes hold. Operator holds no weight and does not need to balance drum truck. Two 6" polyolefin load wheels and two 4" swivel casters provide smooth movement. Designed for rimmed 55-gallon steel drums.

800 lb. capacity



SC955061

POLYETHYLENE CONTAINMENT SUMP Choose Plastic or Wire Deck

Helps prevent costly, illegal environmental contamination. Chemical resistant, high density black polyethylene, 85 gallon capacity sump collects leaks and overflow for easy clean-up. Extra-rigid 50 1/2" sq. x 15 7/8" H sump holds four 55 gallon drums. 4000 lb. static load capacity. Nests for compact storage. Accepts standard 48" sq., or 40" x 48" pallet. Sump is available with or without decking. **Polyethylene Pallet** has molded in barrel rings for stability and allows four-way forklift access. **Wire Decking** is durable, lightweight and includes a powder coat finish for long life. **Polyethylene Decking** is chemical resistant and easily removes for cleaning. **Meets EPA secondary containment standards.** Weather resistant, reinforced **Vinyl Cover** with vents features a cinch closure and clear plastic document pouch.

Model	Description
SC298437	Sump Without Deck
SC298441	Sump With Wire Deck
SC298442	Sump With Plastic Deck
SC298438	Sump With Plastic Pallet
SC846021	Vinyl Cover 51" Sq. x 50" H / 5.3 lbs

MEETS EPA REQUIREMENTS



SUMP ONLY



SUMP W/PLASTIC PALLET



SUMP WITH WIRE DECK



VINYL COVER



SUMP WITH PLASTIC DECK

INDUSTRIAL BENCH/FLOOR SCALE

This digital shipping scale is ideal for multiple uses and environments. Can be used for weighing, counting or as a system to accept or reject items from production line based on weight. 10" H and removable 37" H posts allow display height adjustment for bench and floor scale use. Hand screw knob on post allows quick post removal. Stainless steel platform measures 16 1/2" W x 20 1/2" L. Plastic display measures 9 3/4" W x 6" H and includes LCD screen displaying six 1" H digits for easy-to-read viewing. Hand screw leveling feet allows quick and easy deck height adjustments up to 7" H. Includes leveling indicator for proper weighing. Operating functions include auto-zero, tare, accumulate and counting. Features auto shutoff with sleep mode function. 115V, AC with built-in rechargeable battery, 6' L power cord. 1 year Limited Warranty.

Model	Capacity		Readability		W" x L" x H"
	Lbs.	Kg.	Lbs.	Kg.	
SC236463	330	150	0.1	0.04	11 3/4 x 15 3/4 x 43
SC653295	660	300	0.25	0.11	15 3/4 x 19 3/4 x 51



EASY TO READ 1" H NUMBERS



POST HEIGHT ADJUSTS FOR TABLE TOP OR FLOOR APPLICATIONS



37" H POST CONVERTS IN MINUTES TO A BENCH SCALE



660 lb. capacity



DIGITAL SHIPPING/RECEIVING SCALE

Simple to operate. Rugged low profile steel platform 12 1/4" x 11 3/4". Large, easy to read 1" LCD digital display comes with a 6' coiled cord; includes bracket for wall or surface mounting. Features large keys for tare/hold, units, on and off. Powers off after 2 minutes of non-use. Includes an RS232 serial port. Operates with either an AC adapter (included) or 6-AA batteries (not included). 1 Year Limited Warranty.



400 lb. capacity

Model	Capacity		Accuracy	
	Lbs.	Kg.	Lbs.	Kg.
SC300625	400	181	0.5	0.2



01-800-467-0529

chproductos.com



ELECTRONIC WEIGHT COUNTING SCALE

With a default division of 1/30,000 and Class III accuracy, this scale is capable of counting the smallest of parts. Features sample weigh, count and percent mode functions. **Weighs in pounds and kilograms.** Includes easy-to-read LCD display and RS232-port. Stainless steel platform with protective finish measures 10 1/2" x 8 1/2". Features 60 lb. maximum capacity & 0.5 lb. minimum capacity with .002 lb. increments. Powered by internal rechargeable battery or 110/220V AC adapter (included). 10 1/2"W x 13"D x 4"H overall.

60 lb. capacity

Model	Capacity		Graduation	
	Lbs.	Kg.	Lbs.	Kg.
SC240878	60	30	.002	0.00



ELECTRONIC CRANE SCALE



**With Remote
2000 lb. Capacity!**

Provides a versatile and economic solution for overhead material handling and weighing applications. Makes load connection quick and secure. Aluminum die-cast casing with load cell, hook and shackle. 6V rechargeable battery operates 50 hours between charges and includes battery charger. 1 1/5"H, 5-digit LED display. Includes remote control and swivel hook with safety latch.

Capacity		Accuracy		Model
lbs.	kg.	lbs.	kg.	
2000	1000	1.0	0.5	SC795871



CARTON STAND

Choose from **SINGLE** or **DUAL LEVEL** to meet your needs. Organize corrugated boxes for easy access. 48" x 18" shelves with three 25"H adjustable dividers per shelf and screw type leveling feet for uneven surfaces. Chrome plated finish. Easy assembly.

**DUAL LEVEL
SHOWN W/OPTIONAL
PUSH HANDLE AND CASTERS**

Model	Description	Ht."
SC184204	Single Level	38 1/2
SC184205	Dual Level	78 1/2

OPTIONAL ACCESSORIES

CASTER SET. 4" rubber swivel.

Model SC184233

PUSH HANDLE. Adjusts on 1" increments.

Model SC184234

LOW PROFILE PALLET SCALE



Up to 10,000 lb. capacity



48" x 48" x 4" low profile scales feature steel diamond plate surface with heavy duty welded channel support and closed corner design. Can be pit mounted or free standing on adjustable 2-3/8" diameter rubber feet. Overload protected to 125% of capacity. Scales are legal for trade and come pre-calibrated with corresponding indicator. Indicators are built with durable stainless steel and ABS plastic and measure 4-5/8"H x 8-1/8"W x 2-3/16"D. LCD display with backlight features six 1/2"H digits. Functions include, unit selection (lb/kg), zero, tare, and hold. RS-232 serial port connectivity. Battery/AC power (adaptor included). Models include 9'10" interface cable and 5' AC adapter. 1 Year Limited Warranty.

Scale	Cap. Lbs.	Grad. Lbs.	W" x L"	Ramp
SC242433	5000	2.2	48 x 48	SC236466
SC242434	10000	2.2	48 x 48	SC236466



GUMMED PAPER TAPE DISPENSER



**NTEP APPROVED
"LEGAL FOR TRADE"**

A must for fast efficient packaging, this industrial grade dispenser reliably supplies pre-cut, pre-moistened tape in adjustable lengths up to 42" with one easy lever stroke (and longer lengths with repeated strokes). Features include adjustable water levels, pressure plate and double brush moistening for optimal seals. Generous water tank reduces refill time. Rugged steel housing for years of service. Accepts virtually any gummed tape in widths from 0.8 up to 4". Model SC300713

PARAMOUNT® MOBILE FLIP-TOP TRAINING TABLES

Paramount® Flip Top Training Tables are ideal for Conference Rooms, Classrooms and other Training Applications. Designed for compact storage - flip the top and nest the base. They are constructed with 1" thick laminate/particle board tops, PVC edge banding and a metal base. The base is designed with a metal modesty panel with an integral cable trough. 4 locking casters for easy mobility. Table tops can be connected using 2 ganging clips that are included with each table. **Table top available in Cherry or Gray finish.** Available in 48", 60" and 72" lengths. Easy assembly.



SC277437
MESH CHAIR

SC695125
TABLE



FOLDING INTO
NESTING POSITION



FLIP TOP LEVER MECHANISM



NEST FOR EASY
STORAGE



TABLE GANGING CLIP



SC695220

TOP FINISH

Cherry	Gray	L" x W" x H"
SC695123	SC695218	48 x 24 x 29 1/2
SC695124	SC695219	60 x 24 x 29 1/2
SC695125	SC695220	72 x 24 x 29 1/2

PRESENTATION LECTERNS



SC248631MH

SC248630MH

Great for conference rooms, training rooms, lecture halls and more! Made with sturdy 3/4" thick wood and stain resistant laminate mahogany finish. **Mobile LECTERNS** include retaining platform to hold papers or laptop with fixed shelf (not shown). Features four 2" swivel casters (2 locking) for mobility. **Stand-Up LECTERNS** have a slanted reading surface with pencil groove and paper stop. Includes one height adjustable shelf and floor glides. Easy assembly.

Model	Description	W" x D" x H"
SC248631MH	Stand Up	23 x 15 3/4 x 45 7/8
SC248630MH	Mobile	18 x 18 x 44

STACK CHAIRS WITH FABRIC SEAT

Chairs provide a sleek, modern look and are built for durability and comfort. Durable welded 1" diameter tubular legs for stability. Non-marring glides for easy sliding over floors. Choice of **Breathable Mesh Back** or **Fabric Upholstered Back**. **Mesh Back Chairs** are made with ergonomic mesh backrest and feature sled base. Seat: 17"W x 18"D x 17"H. Back: 17 1/2"W x 17"H. Sold 4 per carton. Assembled. **Fabric Upholstered Back Chairs** feature cushioned backrest with vented plastic back for cool, dry comfort. Seat: 18"W x 20 1/2"D x 18"H. Back: 20 1/2"W x 15"H. 34"H overall. Easy assembly. 1 Year Limited Warranty.



SC277437

SC240220BK

Back	Frame	Base	Model
Mesh	Black	Sled	SC277437
Upholstered	Gray	Tubular Legs	SC240220BK
CHAIR DOLLY		(Holds 12 Chairs)	SCB1144516
CHAIR TRUCK		(Holds 12 Chairs, 6" Rubber Wheels)	SC250801

PARAMOUNT® RECEPTION ROOM FURNITURE

Choose Leather, Fabric
or Anti-Microbial Vinyl Upholstery



PADDED
ARMREST



BLACK
LEATHER

SC250785



ANTI-
MICROBIAL
VINYL

SC250787BY



SC238410GY

Paramount® RECEPTION/WAITING ROOM TABLES are constructed with 1" thick laminate/particle board tops, PVC edge banding and 18 gauge steel tube legs. Square table 19⁷/₈"W x 19⁷/₈"L x 16⁵/₈"H. Rectangle table 19⁷/₈"W x 43¹/₄"L x 16⁵/₈"H. Corner table 29⁷/₈"W x 19⁷/₈"L x 16⁵/₈"H. Ships unassembled. RECEPTION CHAIRS are ideal for office, school, hospital or any area where you need to make guests comfortable. Features large 20¹/₂"W x 19"D seat and 20¹/₂"W x 16"H back (19"H from seat) with 3¹/₂" thick foam cushion. Padded arm rests for added comfort. Sled base includes rubber feet for stability. 1 Year Limited Warranty. Assembles easily.

TABLE STYLE	Cherry	Gray
Coffee Table Square	SC238410CY	SC238410GY
Coffee Table Rectangle	SC238412CY	SC238412GY
Coffee Table Corner	SC238414CY	SC238414GY

CHAIR	Black	Burgundy	Gray
LEATHER	SC250785	---	---
FABRIC	SC250786BK	SC250786BY	SC250786GY
VINYL	SC250787BK	SC250787BY	SC250787GY

PARAMOUNT® NESTING MESH CHAIR



VENTILATED
NYLON
MESH BACK

FIXED ANGLE
ARMRESTS

FABRIC
UPHOLSTERED
SEAT

HOODED DUAL
WHEEL SWIVEL
CASTERS



SEAT EASILY FOLDS UP
TO ALLOW HORIZONTAL
NESTING FOR COMPACT
STORAGE

Mesh back conforms to your body for cool, ventilated comfort. Poly mesh back with built-in lumbar support provides added comfort. Fabric upholstered seat has 2¹/₂" thick cushioning and plastic bottom. 9¹/₂"L x 2"W fixed armrests help reduce arm fatigue. Tubular steel frame with black finish includes dual wheel swivel casters. Seat measures 18"W x 18"D x 19¹/₂"H. Back measures 21"W x 20"H. Easy Assembly. 1 Year Limited Warranty. Sold in qty. of 2. Model SC248624

CHROME GARMENT STORAGE



SC184450
SHOWN WITH
OPTIONAL CASTER KIT



SC184444
CHROME
HANGERS INCLUDED

The attractive solution to garment storage. Durable chrome plated steel wire design minimizes dust accumulation, maximizes ventilation. Resists denting, chipping and rusting. Shelf adjusts on 1" increments. All models are 24" deep. Includes chrome plated hangers. Wall Rack easily attaches to wall surface to save floor space. Two Shelf Floor Rack is 63"H, Three Shelf is 74"H. Optional Caster Kit adds additional 6" to height. Easy assembly.



EXTRA
VALUE
COAT
RACK

W" Hangers	WALL RACK FLOOR RACK FLOOR RACK		
	One Shelf	Two Shelf	Three Shelf
36 12	SC184444	SC184447	SC184450
48 18	SC184445	SC184448	SC184451
60 24	SC184446	SC184449	SC184452

OPTIONAL CASTER KIT Includes four 5" swivel casters. Model SC184453

EXTRA VALUE COAT RACK Extends from 41" to 60"W. 4" swivel casters, two locking. 65¹/₂"H x 20"D. Order optional hangers below. Model SC506584

CHROME PLATED HANGERS 17"L. Package of 6. Model SC651262

GLOBAL 1000 WATT COMMERCIAL MICROWAVES

NEW



NSF

SC242935

Powerful units with small footprints. Commercial 1000 watt microwaves are ideal for quick, efficient heating of soups, sandwiches, prepackaged lunches, beverages. Use in kitchens, break rooms, convenience stores and more. Multi-power levels allow easy control of heat and cook time. Heavy duty to withstand fast-paced environments with multiple users. 115 Volts.

Brand	Controls	Cu. Ft.	W" x D" x H"	Model
Global Equipment	Dial	0.9	20 ¹ / ₈ x 16 ³ / ₄ x 12 ¹ / ₄	SC242935

ADJUSTABLE DISH CADDY

NEW



Store a combination of different dish sizes on this adjustable dish caddy. Each caddy comes with six easily adjustable towers for safe stacking of 40 - 50 plates per column. Holds plates from 4³/₄" - 12" diameter. Durable polyethylene construction will not chip or crack and protects china from chipping. Two 10" wheels and two 5" swivel casters, with brakes. 500 lbs. capacity. Comes with vinyl cover. 28¹/₂"W x 37¹/₂"D x 31¹/₂"H. Gray



SC242928

GREAT VALUE!

NSF

CASH HANDLING



SCB1476806



SCB1476808



SC256569

Keep your money and valuables safe with these cash handling products. From cash trays and boxes to cash registers, you will find a product that lets you count, sort, and secure your money. Ideal for banks, casinos and retail stores, your finances will be properly protected, ensuring your money is handled responsibly.

Model	Description
SCB0955491	\$100 Currency Band (Pk of 1000)
SC256571	Assorted Coin Wrappers, Pack of 360
SCB442587	Tamper-Evident Deposit Bags (Pk. of 100)
SCB442981	Cash Box With Security Lock, Set of 4
SCB442994	Touch Button Cash Drawer
SCB1476808	Ultraviolet Currency Counter
SCB0684348	Digital Cash Counter
SCB1476806	4 Row Digital Coin Sorter
SCB1001678	Sharp Cash Register

GLOBAL INDUSTRIAL MAGNIFYING LAMPS

Global Industrial's Premium 2-In-1 Lighting and Magnification Lamps are ideal for crafts, hobbies, medical and beauty needs and general precision work. Large viewing area defines details and the unique double tension safety arm helps eliminate pinching and injury. 5" round glass lens includes a hinged, dust-proof cover. 3, 5 or 8 diopter options available. Clamp Mount attaches to any desk with a tabletop thickness of 2-1/2" or less to hold the lamp safely and securely. Fluorescent lamp uses a T4 22 watt circular bulb. LED lamps use 80 ultra-efficient SMD LED bulbs which offer glare-free light. UL Listed.



SC695231

UL



LED LAMPS
USE 80 SMD
LED BULBS



SC695232

Diopter	Bulb	Model	Color
3	Fluorescent	SC277494	Black
3	LED	SC695231	Black
3	LED	SC695232	White
5	LED	SC277493	Black
5	LED	SC695233	White
8	LED	SC277665	Black
8	LED	SC695234	White

ANALOG & DIGITAL WALL CLOCKS

Wall Clocks are great for time display in offices, schools, warehouses and more. Choose from Analog or Digital Wall Clocks which come in a variety of colors and sizes to fit your needs.



Model	Description	Qty
SC252913BK	Advance 8" Plastic Wall Clock	3
SC252920	Geneva 13.5" Quartz Plastic Wall Clock	3
SC252922	Geneva 14" "Info-Tech" Wall Clock	3
SC252921	Geneva 14" Quartz Plastic Wall Clock	3
SC219103	Global Industrial 15" Wall Clock	1
SC252925BK	Geneva 14" Electric Quartz Wall Clock	3
SC252928	Geneva Digital Radio Controlled LCD Wall Clock	3
SC571285	Global Industrial Wall Clock Double Sided	1
SC651250	Global Industrial Digital Wall Clock	1

VENTILATED PLASTIC STACK CHAIRS

Contoured plastic back is vented for superior comfort. Waterfall edge seat helps improve leg circulation and reduce fatigue. Durable welded 1" diameter tubular sled base for rigidity. Base includes interlocking brackets that joins chairs in rows. Seat: 18"W x 18¹/₂"D x 18"H. Back: 20"W x 16"H. Sold 4 per carton, all one color. 1 Year Limited Warranty.

Black	Blue
SC250606BK	SC250606BL
SCB1144516	CHAIR DOLLY
(Holds 12 Chairs)	
SC250801	CHAIR TRUCK
(Holds 12 Chairs, 6" Rubber Wheels)	



Merion VENTED BACK MOLDED CHAIRS



SC921397BL



SC808665BK

Contoured back support design and ventilating slot for comfortable seating. Polypropylene shell with tubular steel frame endures long term use. Non-marring glides. Stacks compactly at 2" H increments! Seat: 17"W x 16"D x 16"H and 17"H from floor. Sold 4 per carton. 1 color same style per carton. **Add color suffix: Black (BK) or Blue (BL).** Arm Chair not available in Burgundy (BY). 2 Year Limited Warranty.

Style	Model
Armless Chair	SC808665
Arm Chair	SC921397



SC808665BY

CHAIR DOLLY (Holds 12 Chairs) SCB1144516
CHAIR TRUCK (Holds 12 Chairs, 8" Rubber Wheels) SC250801

Oakmont ERGONOMIC CHAIRS



SC240221BK
 PLASTIC SEAT
 AND BACK

	Model
Plastic	SC240221

Sleek styling suits office and lounge decors. High density stacking for compact storage. Tubular steel frame is built to last. Ergonomic comfort. Hard-wearing plastic seat and back. Seat: 18"W x 16"D. Back: 18"W x 13"H. Sold 4 per carton, all 1 color. **Add color suffix: Black (BK), Burgundy (BY), Blue (BL) or Gray (GY).**

CHAIR DOLLY (Holds 12 Chairs) SCB1144516
CHAIR TRUCK (Holds 12 Chairs, 8" Rubber Wheels) SC250801

Augusta STACKABLE CHAIRS



BLUE SEAT
 SILVER
 FRAME

Provides years of maintenance free service. Vinyl covered, 1 1/2" thick foam padded seat and back. 7/8" square-tube, 18-gauge steel frame with nylon glides to protect floor. ANSI/BIFMA approved. Seat is 16" square. Back tapers from 15"W to 12"W x 17"H. 33 1/2"H overall. Sold 4 per carton, all one color.



Seat:	Black	Blue	Brown
Frame:	Black	Silver	Mocha
	SC921398BK	SC921398BL	SC921398BN

CHAIR DOLLY (Holds 12 Chairs) SCB1144516
CHAIR TRUCK (Holds 12 Chairs, 8" Rubber Wheels) SC250801

Cypress Point CHAIRS

Upholstered seating with padded seat and back. Black accent armrests. Heavy-duty chrome frame is 18-gauge, 3/4" square-tube steel with built-in floor glides. Upholstered in soft, durable black vinyl or fabric. Seat and Back: 16" square each. Sold 4 per carton.



SC506530BK



SC506531BK

Upholstery	Model
Vinyl Armless	SC506529BK
Vinyl w/ Arms	SC506531BK
Fabric Armless	SC506530BK

CHAIR DOLLY (Holds 12 Chairs) SCB1144516
CHAIR TRUCK (Holds 12 Chairs, 8" Rubber Wheels) SC250801

WESTCHESTER BANQUET CHAIRS

These heavy duty banquet chairs feature 2 welded support bars on the sides and 2 on the bottom for extra frame support and rigidity for extended service life. Generous 16 1/2" square seat has plush 2 1/2" thick cushioning and double sewn seams. **Strong 16 gauge steel frame** is black powder coated for scratch resistance, has protective stacking bumpers and non-marring floor glides. The large cushioned backrest is fully upholstered on both sides and has convenient hand hold cutout for easy lifting and stacking. Back: 16"W x 19"H. 37"H overall. Sold 4 per carton, all one color. **Add color suffix: Black (BK) or Blue (BL).**

Model	Description
SC773299	Vinyl Upholstered
SC773300	Fabric Upholstered

CHAIR DOLLY (Holds 12 Chairs) SCB1144516
CHAIR TRUCK (Holds 12 Chairs, 8" Rubber Wheels) SC250801



Pinehurst CHAIRS

STACK COMPACTLY
 TO SAVE SPACE



SHELL
 BACK



Elegant modern styling and hard-wearing construction add up to exceptional value. 2" thick foam cushions are contoured for comfort and upholstered with durable nylon fabric to withstand heavy use. Sturdy steel frame has chip resistant powder coat finish. Seat and back feature a plastic shell backing to extend service life. Optional polyurethane armrests. Seat: 19 1/2"W x 18 1/2"D. Back: 18 1/2"W x 13 1/2"H. Easy assembly.

Description	Blue	Burgundy	Gray	Black
Armless Chair	SC516278BL	SC516278BY	---	SC516278BK
Arm Chair	SC516279BL	SC516279BY	SC516279GY	SC516279BK

CHAIR DOLLY (Holds 12 Chairs) SCB1144516
CHAIR TRUCK (Holds 12 Chairs, 8" Rubber Wheels) SC250801

EXTRA VALUE PLASTIC FOLDING TABLES

Designed to set up in seconds to meet your temporary or permanent requirements for training, security stops, parties or lunchrooms. Low maintenance polyethylene tops are lightweight and resist moisture and stains. Reinforced 1 1/8" diameter steel tubular frame and legs add stability and strength. Safety locks keep tables open when in use and prevent unfolding when stored. Both styles ship assembled and include a 2 Year Limited Warranty.

Style A legs fold in for a storing thickness of 1 3/4". Tabletop measures 30" x 72".

Style B folds in half to measure only 29"W x 36"L x 3 3/4" thick and includes convenient carry handles. Opens to 29" x 72". Ships UPS.

Style C Legs fold in for a storing thickness of 1 3/4". Choice of table top diameter of 48", 60", or 71".

Style	Model	L" x W"
A	SC506750	72 x 30
A	SC277626	96 x 30
B	SC506801	72 x 29

ROUND	
Style C	Dia."
SC256559	48"
SC256560	60"
SC256561	71"

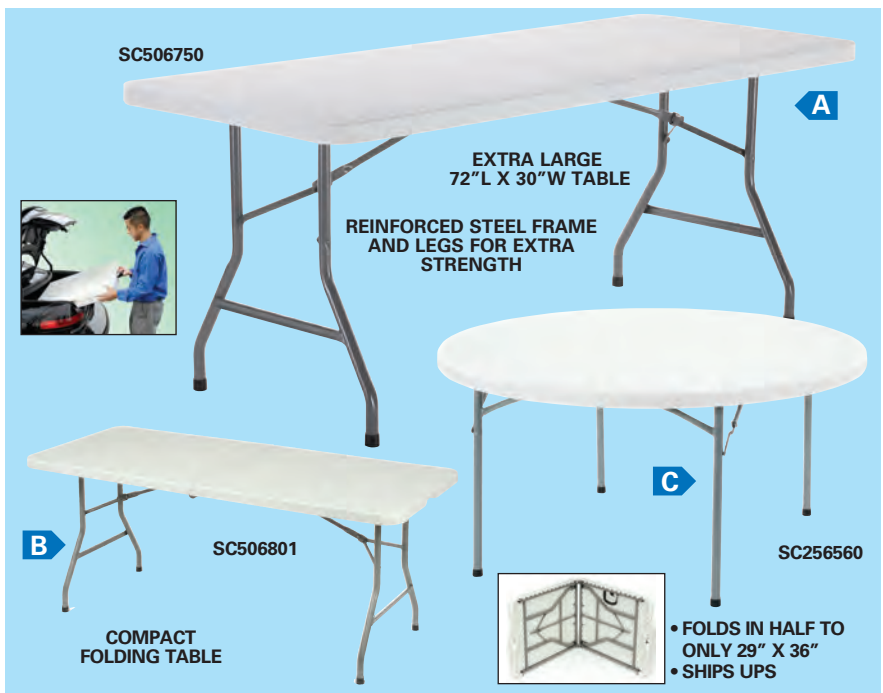

FOLDING CHAIR & TABLE CARTS

Store & transport chairs and tables with ease. Organize and store temporary furniture. Moves easily on non-marring 4" heavy duty swivel casters. 2" welded angle steel with brown finish. Flat Stacking carts store folding chairs or tables in the horizontal stacked position. Edge Standing carts store folding chairs or tables in an easy accessible upright position. Double Sided Hanging Cart stores folding chairs in an easy accessible hanging position. Combo Hanging Cart holds folding chairs and tables on a single unit. Optional Coat Rack Kit includes 2 removable garment rods that easily install on empty Hanging Carts to convert cart into mobile coat racks. Easy assembly. 1 Year Limited Warranty.

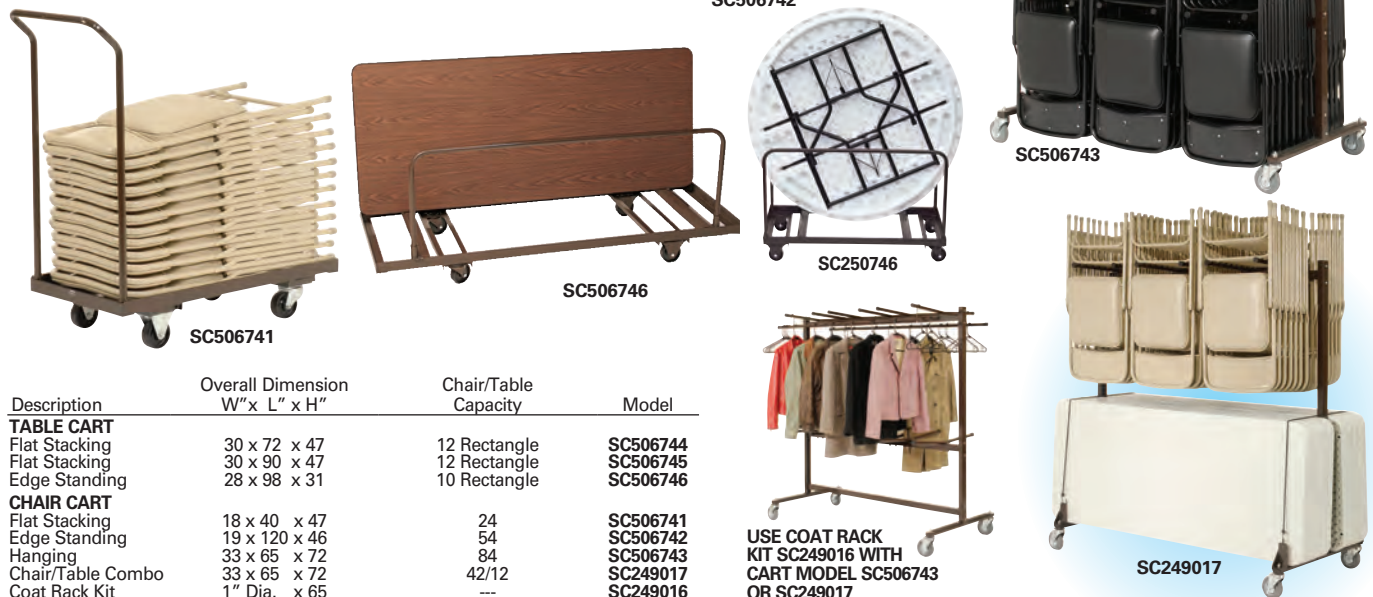

Description	Overall Dimension W" x L" x H"	Chair/Table Capacity	Model
TABLE CART			
Flat Stacking	30 x 72 x 47	12 Rectangle	SC506744
Flat Stacking	30 x 90 x 47	12 Rectangle	SC506745
Edge Standing	28 x 98 x 31	10 Rectangle	SC506746
CHAIR CART			
Flat Stacking	18 x 40 x 47	24	SC506741
Edge Standing	19 x 120 x 46	54	SC506742
Hanging	33 x 65 x 72	84	SC506743
Chair/Table Combo	33 x 65 x 72	42/12	SC249017
Coat Rack Kit	1" Dia. x 65	---	SC249016

USE COAT RACK
KIT SC249016 WITH
CART MODEL SC506743
OR SC249017

PLYWOOD FOLDING TABLES



Heavy duty Plywood Folding Tables are ideal for banquet halls or hotels. Solid plywood core table top construction is completely sealed with UV protective coating to enhance durability. 3/4" thick top with reinforced vinyl T-molding protect table edges & corners. Heavy gauge 1" diameter steel leg construction with safety lock is built for commercial use. 30"H. Assembled. 3 Year Limited Warranty.

W" x L"	Model
18 x 72	SC277444
30 x 72	SC277445
30 x 96	SC277446
60 Round	SC277447

BEST VALUE 6-FOOT FOLDING TABLE



Model
SC250794

Folding table has a gray finish melamine surface that is scratch and stain resistant. 3/4" thick table top has a protective mold edge banding. **1200 lb. capacity.** Tubular steel legs have a scratch resistant dark gray powder coat finish. Locking clips secure legs in the open position. **Folds to only 2" thick!** Table measures 72"L x 30"W x 29"H. 1 Year Limited Warranty.

PARAMOUNT® ALUMINUM CHAIRS



SC695251



Model
SC695251
SC695253



SC695253

Paramount® Aluminum dining chairs are used for a variety of indoor and outdoor seating applications. Chairs are constructed of aluminum for long lasting durability. Simple and sleek contemporary designs provide efficient seating. Easy to maintain. Overall dimensions 15 1/3"W x 20 1/2" D x 33"H. Available in two Slat Back styles. Color finishes Aluminum. Sold in package quantities of 2, priced each.

BEST VALUE PLASTIC PICNIC TABLE

Durability & Versatility for An Affordable Price!

This corrosion resistant picnic table is ideal for any environment including cafeterias, lunchrooms, parks and more for both outdoor and indoor use. Durable, double walled plastic table top and benches are made to last and won't fade or corrode. **72"L table includes two 9"W x 18"H benches** to fit up to 8 people comfortably. Light gray table top measures 30"W x 30"H. Sturdy tubular steel frame has a scratch resistant gray powder coat finish and stabilizing floor glides. Easy-to-clean plastic top provides low maintenance using only soap and water. 1 Year Limited Warranty. Easy assembly.

Model
SC250793

UNIVERSAL ANCHOR KIT { For Grass
For Asphalt or Cement

Model SC744112
Model SC744113



DURABLE DOUBLE REINFORCED STEEL FRAME



INDOOR/OUTDOOR PLASTIC PICNIC TABLE

These picnic tables are ideal for industrial, residential or commercial application. The tabletops and seats are manufactured from high-density polyethylene which will not corrode, never need painting, toxic chemical treatments or coatings. Table top measures 72"L x 28 1/2"D x 29"H. Seat measures 72"L x 12"D. Overall dimension is 72"L x 58"D x 29"H. High strength, tubular steel frames feature exterior grade, epoxy finish. Maintenance-free. Easy clean-up with soap and water. 1 Year Limited Warranty. Easy assembly.



REINFORCED TUBULAR STEEL SCAME WITH EPOXY FINISH

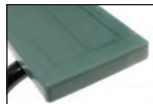

GREEN SLAT



SC248992TN

CORROSION RESISTANT HIGH DENSITY POLYETHYLENE TOP AND SEATS

TOP/SEAT: FRAME:	Tan Black	Green Black
72"L	SC248992TN	SC248992GN

UNIVERSAL ANCHOR KIT { For Grass
For Asphalt or Cement

Model SC744112
Model SC744113

GLOBAL THERMOPLASTIC COATED METAL PICNIC TABLES & BENCHES

Heavy gauge metal picnic tables and benches are ideal for seating areas in parks, campuses, snack bars and more. Protective coating creates a smooth, high-gloss surface that stays cool to the touch for comfortable seating even in the sun. Thermoplastic coating resists fading, mold and vandalism, and will ensure maintenance-free durability through years of high-traffic usage. Rugged galvanized tubular steel frame is shielded with a black powder coat finish for rust-prevention and resilience against the elements. Bench and table corners are beveled for safety. **7 Year Limited Warranty.** Tabletops include a 2" diameter opening to accept an umbrella pole.



SC277150GN



SC694551GN



SC277154GN



SC277156BL



SC277152BL



PERFORATED METAL is 11 gauge with 1/2" holes on staggered centers



EXPANDED METAL is 9 gauge that forms a diamond pattern

TABLE AND BENCHES

Size"	Description	EXPANDED METAL	PERFORATED METAL
72 x 30	Rectangular Picnic Table	SC277152	SC694553
96 x 30	Rectangular Picnic Table	SC277153	SC694555
46	Square Picnic Table	SC277151	SC694551
46	Round Picnic Table	SC277150	--
72	Bench With Backrest	SC277154	SC694557
96	Bench With Backrest	SC277155	--
72	Flat Bench	SC277156	--
96	Flat Bench	SC277157	--

Add color suffix : Blue (BL), Green (GN) or Black (BK)

GLOBAL PICNIC TABLE UMBRELLAS



SC695267



SC695256

Perfect for hotel, restaurant, or residential use, this umbrella is ideal for any outdoor occasion. Made of quality grade, fade-resistant polyester fabric, this umbrella fully opens to 8 1/2 feet to give you plenty of shade. Sturdy anodized aluminum pole comes in 2 pieces which snap in together for easy assembly. 8 square aluminum ribs on the underside keep the umbrella steady in windy conditions. Top air vent provides wind and heat ventilation while crank lever makes it easy to set up and open. Can be used with picnic tables with umbrella hole 1 1/2" or more. **Umbrella Base** adds upright stability for the umbrella. Weighs 30 lbs and is made of powder coated cast iron providing durability against any weather condition. Ideal for use with picnic tables.



SC695257

Model	Description	Diameter"	H"	Color
SC695256	Umbrella	102	90 1/2	Blue
SC695257	Umbrella	102	90 1/2	Green
SC695267	Umbrella Base	20	12	Black

STEEL SLAT BENCH



SC694854

Heavy Duty steel commercial bench is ideal for train stations, park facilities, shopping areas or any outdoor environment requiring seating. Finished in thermoplastic green coating, this durable bench can withstand even the harshest outdoor climates. Pre-drilled mounting holes allow the option to mount to any surface. Ships fully assembled.

Model	Description	Wt. Lbs.
SC694854	6' Slat Park Bench	192
SC694855	8' Slat Park Bench	256

RECYCLED PARK BENCH

Made from **recycled wood and plastic** composite that's UV, moisture and scratch resistant. Solid green slats are supported by wrought iron legs. 17" D seat. 28" H overall. Feet include anchor openings. Stainless hardware. Pre-drilled slats for easy assembly. 1 year Limited Warranty.



SC240126



SC240125

Model	Description	Wt. Lbs.
SC240125	4' Bench	131
SC240126	6' Bench	166



SC695295



SC695289



SC695290



Steel Picnic Tables are **ADA compliant** and feature additional leg space for handicap accommodation. Rectangular tables offer an extra 24" of overhang on either side while the round and square tables feature one less bench. Tables are commercial grade, made of high gauge metal and coated with a rugged thermoplastic layer that resists fading, mold and vandalism. Black powder coat steel frame is rust-proof. All tables include a 2" diameter opening to accept an umbrella pole. **Surface Mount** tables can either be portable or secured down through use of anchors (sold separately). **In-Ground Mount** Tables are to be installed in cement. 7Year Warranty.

Model	Mount Type	Shape	Table Size"	Overall W" x L"
SC695290	Surface Mount	Round	46	84 x 65
SC695291	Surface Mount	Square	46	81 x 63
SC695289	Surface Mount	Rectangular	96 x 30	96 x 60
SC695294	In-Ground Mount	Round	46	84 x 65
SC695295	In-Ground Mount	Square	46	81 x 63
SC744113	Anchor Kit for Concrete	---	---	---
SC744112	Anchor Kit for Grass	---	---	---

*Use Color Suffix: Black (BK), Green (GN) or Blue (BL)

IN-GROUND MOUNT PICNIC TABLES



EXPANDED METAL is 9 gauge that forms a diamond pattern



SC695292

Model	Shape	Size"
SC695292	Round	46
SC695293	Square	46

*Use Color Suffix:
Black (BK), Green (GN)
or Blue (BL)

These picnic tables feature a single mounting post design that has table and benches attached to only 1 post for easy installation, cleaning and maintenance. 9 gauge expanded metal features a diamond pattern. Thermoplastic coating provides optimum durability and stands up to the elements, making tables and benches great for outdoor use. Strong galvanized, powder-coat finished steel frame will not fade, crack or peel. Corners are rounded for safety. Table top features a 2" diameter opening to accept an umbrella with a pole of up to 1 1/2" diameter (Umbrellas & Umbrella Bases sold separately). To be installed in concrete only. Easy assembly.

STACKABLE MEDIA STORAGE CABINET



2 STACKED WITH
OPTIONAL BASE

Model	Description
SC249043	4 Drawer Cabinet
SC249044	Cabinet Base

These heavy gauge welded steel cabinets allow you to mix and organize media the way you want it! Cylinder lock with 2 keys secures all drawers, chrome plated handles and label holders. Includes four 6"H drawers with full extension drawer glides. Each drawer includes 6 front-to-back steel rod dividers that adjust at 1/2" increments and book end dividers that adjust at any point along the rod to securely hold media in place. Putty finish cabinet & base. Cabinets stack for added storage. 37"W x 17 1/2"D x 27 3/4"H. **Optional Base** adds 5" to height. 1 Year Limited Warranty.



Adjustable dividers store and organize DAT, VHS, DVD and up to 240 CDs per drawer

ELECTRONIC 48 KEY SAFE CABINET



SC270299

Battery operated electronic lock wall safe holds 48 keys. Made of durable heavy-gauge steel, with a sand-colored chip and scratch resistant finish. The Electronic Key Safe will keep your keys and valuables safe and secure. The programmable, battery operated key pad eliminates the need for keys; a removable faceplate reveals a back-up key lock, in the event of a power failure. **Key tags are included.** Measures 12"W x 4"D x 17 3/4"H.

INTER-OFFICE MAILBOXES



Office mailboxes keep private inter-office correspondence confidential. Durable steel with a gray powder coat finish. Cylinder lock with 2 keys and full-length piano hinged door. Mailboxes easily mount to wall (hardware not included).

Model	W" x D" x H"
SC443490	12 x 3 x 10
SC443491	18 x 7 x 18

KEY CABINET



SC493319

Allows for easy identification and secure storage of keys. Solid steel construction. Disc tumbler lock with 2 keys. Pre-drilled holes and fastening hardware for easy mounting to wall or door. Key tags included. Powder coat sand finish.

Model	Key Cap.	W" x D" x H"
SC493318	30	8 x 2 1/2 x 12 1/8
SC493319	60	10 1/2 x 3 x 12 1/8
SC270298	110	14 x 3 1/8 x 17 1/8

PARAMOUNT® HEAVY DUTY STORAGE CABINETS

Choose 36" or 48" Wide Assembled
or Easy To Assemble...

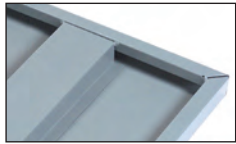

BOX FORMED CHANNEL
REINFORCED SHELVES
ADJUST ON 2" CENTERS



48" BASE IS I-BEAM
REINFORCED FOR
ADDED STRENGTH



EXCLUSIVE DUAL
CHROME DIECAST KEY
LOCKING HANDLE



3 POINT LATCHING
SYSTEM WITH SOLID
STEEL 5/16" ROD



HEAVY DUTY
4" x 3/8" HINGE
EXCLUSIVE



REINFORCED
ACRYLIC
WINDOW
DOORS

CHANNEL
REINFORCED,
BOX FORMED
DOORS



SC603599TN

NYLON GLIDES
FOR SMOOTH &
QUIET OPERATION



SC237668GY

ADDITIONAL
SHELVES
Pkg. of 2
Model

SOLID DOOR W" x D" x H"	Model	ADDITIONAL SHELVES Pkg. of 2 Model
EASY ASSEMBLY		
36 x 18 x 78	SC603355	SC237517
36 x 24 x 78	SC493310	SC493314
48 x 18 x 78	SC493311	SC493315
48 x 24 x 78	SC603357	SC237518
ASSEMBLED		
36 x 18 x 78	SC603599	SC237560
36 x 24 x 78	SC493312	SC493316
48 x 18 x 78	SC493313	SC493317
48 x 24 x 78	SC603600	SC237651
CLEARVIEW DOOR EASY ASSEMBLY		
36 x 18 x 78	*SC237614	SC237580
48 x 24 x 78	SC237615	SC237581
ASSEMBLED		
36 x 18 x 78	*SC237620	SC237652
48 x 24 x 78	SC237621	SC237653

*Available in Gray and Tan only. Durable powder coat finish. Add color suffix: Black (BK), Tan (TN) or Gray (GY). Assembled cabinets are non-returnable.

300 lb. Shelf
Capacity



STORAGE CABINET

Assembles With
Only 4 Screws!

Global offers the best value on the market with improved features, easy assembly, and stronger, more durable construction. Ideal for storing office and industrial supplies, these storage cabinets are easy to assemble, with steel box formed doors for added strength. 3-point locking system with 5/16" thick locking rod adds strength and rigidity. Recessed locking handle with 2 keys for safety and security. Includes 4 height adjustable shelves with 185 lb. shelf capacity. Reinforced shelves adjust at 1/4" increments. 36"W x 18"D x 72"H. Durable powder coat finish. Add color suffix: Gray (GY), Black (BK), or Tan (TN).

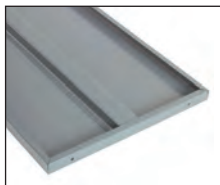

CHANNEL REINFORCED
SHELF



RECESSED HANDLE

185 lb. Shelf
Capacity

CABINET Model SC237635
ADDITIONAL SHELVES
(Pkg. of 2) Model SC269840



PARAMOUNT® STEEL FLAT FILE

Premium Features Throughout! Top Quality at an Unbelievable Price!

Premium, 5-drawer flat file keeps valuable documents stacked perfectly flat and curl-free with hinged paper depressors and rear drawer hood. Drawer fronts have double panel construction with chrome plated drawer pulls and convenient label holders. Sturdy steel construction with internal channel reinforcements permits stacking. Drawers slide smoothly on easy-glide ball bearing rollers and precision drawer runners. Each drawer holds up to 1000 sheets or 25 lb. **Optional Closed Black Base** raises unit 4" off the floor. Chip and scratch resistant furniture grade finish.



SC506825GY
2 FILES WITH OPTIONAL BASE



Model SC506826PY



NYLON ROLLER AND BUMPER FOR SMOOTH AND QUIET OPERATION



HINGED PAPER DEPRESSOR KEEPS DOCUMENTS PERFECTLY FLAT

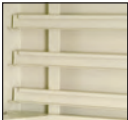

INTERNAL STRUCTURAL CHANNEL REINFORCEMENT FOR EXTRA DURABILITY



EASY-GLIDE DRAWER RUNNERS

Gray Model	Putty Model	CABINET W" x D" x H"	INSIDE DRAWER W" x D" x H"	4" CLOSED BLACK BASE Model
SC506825GY	SC506825PY	40 ³ / ₄ x 28 ³ / ₈ x 16	37 x 25 ³ / ₄ x 2	SC506828BK
SC506826GY	SC506826PY	46 ³ / ₄ x 35 ³ / ₈ x 16	43 x 32 ³ / ₄ x 2	SC506829BK
SC506827GY	SC506827PY	53 ³ / ₄ x 41 ³ / ₈ x 16	50 x 38 ³ / ₄ x 2	SC506830BK

EXTRA VALUE LATERAL FILE

Keep paperwork organized in these attractive filing cabinets. Ball bearing slides allow for full drawer extension, enabling complete access to all documents. Drawers accept both letter and legal sized folders filing side to side. Includes **Front to Back Bars** convert drawer to 2 rows of front to back filing. Designed with an anti-tip interlock mechanism to permit only one drawer to be open at a time. Equipped with adjustable leg levelers for uneven floors. **Comes with central lock with keys.** Recessed handle prevents accidental snags. Durable scratch and chip resistant powder coat finish. 18"D. **5 Drawer Models** have retracting top drawer. 1 Year Limited Warranty.

Includes Central Lock!

30"W x 18" D LATERAL FILE			36"W x 18" D LATERAL FILE	
Model	Drawers	Ht."	Model	
SC252590	2	28	SC252469	
SC252467	4	52	SC252470	
SC252468	5	64 ¹ / ₂	SC252471	

Add color suffix to Model:
Black (BK) or Putty (PY)



SC252469BK



ACCEPTS LETTER AND LEGAL SIZE



FULL DRAWER EXTENSION



CONVERT FRONT TO BACK FILING



CENTRAL LOCK WITH KEYS



SC252471BK

SC252470PY

Global Industrial Mobile Whiteboards are double sided, providing twice the functional writing space than traditional wall mounted whiteboards. Painted Steel surface resists staining and ghosting. 3" casters allow the board to be easily transported from room to room to for continued work and use. Use heavy duty magnets to hang notes, ideas and reminders. **Mobile Reversible Whiteboards** rotate 360 degrees on a pivot hinge and locks into 3 places for better viewing. Total height is 71 1/2". Full length tray keeps markers, erasers and other accessories in close reach. Neutral color steel powder-coated frame. **Whiteboard Room Dividers** are multi-functional and can double as portable working space or a room divider. This board is perfect for collaborative teamwork and sturdy U-legs make transporting from area to area easy. Panel trim is finished with self-extinguishing extruded polymer that offers optimum safety and rigidity. **Deluxe Room Dividers** include cherry finished wood cap to elevate your room's decor. Various sizes and heights available.

MOBILE WHITEBOARDS AND ROOM DIVIDERS



SCB444999



SC694944MBA

Model	Description	Board W" x H"
SCB444997	Mobile Reversible Whiteboard	48 x 36
SC695126	Mobile Reversible Whiteboard	72 x 40
SCB1854285	Mobile Reversible Whiteboard	96 x 48
SC694942MBA	Whiteboard Room Divider	36 x 60
SC694943MBA	Whiteboard Room Divider	36 x 72
SC694944MBA	Whiteboard Room Divider	48 x 60
SC694945MBA	Whiteboard Room Divider	48 x 72
SC694946MBA	Deluxe Whiteboard Room Divider	36 x 60
SC694947MBA	Deluxe Whiteboard Room Divider	36 x 72
SC694948MBA	Deluxe Whiteboard Room Divider	48 x 60
SC694949MBA	Deluxe Whiteboard Room Divider	48 x 72



WALL MOUNT WHITEBOARDS

Essential for any workspace, whiteboards are designed to fit your everyday needs at home, work or school. Available in a variety of surface materials and sizes to accommodate any space. All whiteboards are wall hung and offer a magnetic board, allowing it to double as a bulletin board. Accessory tray and mounting hardware included.



SCB880024

SC694951



Model	Description	W" x H"
SCB880023	Painted Steel Whiteboard with Aluminum Trim	36 x 24
SCB880024	Painted Steel Whiteboard with Aluminum Trim	48 x 36
SCB880012	Painted Steel Whiteboard with Aluminum Trim	72 x 40
SCB880013	Painted Steel Whiteboard with Aluminum Trim	96 x 40
SCB179190	Porcelain Whiteboard with Aluminum Trim	72 x 48
SC694951	Global Industrial Dry Erase Markers, Set of 4	—

PARAMOUNT® BIG & TALL LEATHER EXECUTIVE CHAIR

Big and tall leather chair has soft bonded leather upholstery and a thick frame that supports up to 400 lbs. Stylish chrome plated arms and base provides an attractive appearance. Armrests are padded for increased comfort. Includes an adjustable headrest for added support. Ergonomic adjustments include tilt tension and pneumatic seat height adjustment with tilt lock. Seat measures 23 1/2"W x 21 1/2"D. Back is 23"W x 35"H. Stable 5-blade base includes hooded swivel casters. BIFMA approved. 1 Year Limited Warranty. Easy assembly. Model **SC694738**



SIDE VIEW



THICK COMFORT CUSHIONED LEATHER UPHOLSTERY



PADDLED CHROME PLATED ARMRESTS

HEIGHT ADJUSTABLE PADDLED HEADREST



BUILT-IN LUMBAR SUPPORT

WATERFALL EDGE SEAT

HOODED DUAL WHEEL SWIVEL CASTERS

PNEUMATIC SEAT HEIGHT ADJUSTMENT WITH TILT LOCK

CHROME PLATED BASE



Glass Marker Boards offer all the benefits of a traditional whiteboard with a contemporary modern look. Durable tempered glass surface allows for smooth writing and will not stain, ghost or dent. **Wall Mounted Stainless Steel Boards** include standoff hardware which mount the board 1" off the wall, adding depth and dimension. Magnetic boards can double as a bulletin board through the use of high powered magnets (sold separately). **Mobile glass board** has a lock and pivot system that allows the glass to tilt for better viewing.



SCB1429451

GLASS MARKER BOARDS



Model	Description	Board W" x H"
SC695260	Global Magnetic Glass Dry Erase Board	48 x 36
SCB1429451	Luxor Mobile Glass Board	30 x 40
SC695259	Global Magnetic Glass Dry Erase Board	72 x 48
SCB1342322	Quartet Magnetic Glass Black Board	96 x 48
SCB621688	Balt Magnetic Glass Dry Erase Boards	96 x 48
SCB1400758	Super Magnets	—

EXTRA VALUE BIG & TALL SEATING

450 lb. capacity!



Combines comfort and sturdy reinforced construction at an exceptional value. Features an extra plush 4" thick 23"W x 21"D seat cushion and large 4" thick 23"W x 27"H back. Contoured design includes lumbar support for proper sitting posture. Covered in durable Scotchgard™ Olefin fabric. Includes tension tilt adjustment, tilt lock and pneumatic 17 1/2"-22" seat height adjustment. Accented with an attractive aluminum five star base featuring dual casters for easy mobility. **Optional Adjustable T-Arms** feature 1" side-to-side and 2 1/2" vertical adjustment. Easy assembly. 1 Year Limited Warranty.

SHOWN WITH
OPTIONAL
LOOP ARMS



Description	Blue	Black	Gray
No Arms	SC808666BL	SC808666BK	SC808666GY
Loop Arms	SC506571BL	SC506571BK	SC506571GY
Adjustable T-Arms	SC506572BL	SC506572BK	SC506572GY

BIG & TALL EXECUTIVE CHAIR



BIG & TALL MANAGER CHAIR



Total comfort for the "Big & Tall". Reinforced, sturdy construction for longer life. Ultra-thick 3 3/4" foam cushioning. Genuine black leather. Extra wide and high, 22 3/4"W x 22"D seat and 21 5/8"W x 29 7/8"H back. Pneumatic 18 1/2" to 21 1/4" height adjustment, height adjustable armrests help reduce arm fatigue and tilt-lock mechanism will help increase overall productivity. Sturdy five blade aluminum base with dual wheel swivel casters for added comfort. Easy assembly. 1 Year Limited Warranty. Model **SC277488**

"Big & Tall" Managers Chair is perfect for any environment. Black fabric upholstered chair ensures exceptional value and ultra comfort. The contoured seat is 3 1/2" thick and measures 21 5/8"W x 19 5/8"D. Back cushion measures 19 5/8"W x 29 1/8"H for balanced support. Pneumatic seat height adjustment ranges from 18 1/8"-22 3/4". Seat and back adjustable tilt lock keeps pressure off the knees and helps improve circulation. Height adjustable armrests help reduce fatigue. Sturdy five blade aluminum base with dual wheel swivel casters for added comfort. Easy assembly. 1 Year Limited Warranty. Model **SC277489**

MESH BACK TASK CHAIR



This Mesh Back Task Chair with a fabric upholstered seat is perfect for offices, conference rooms, seminars and more. Ergonomic design conforms to body for cool, ventilated and supportive comfort. 16 1/2"H x 17 3/4"W plastic trim backrest ensures long lasting durability and built-in lumbar support provides added back comfort. 13/4" ratchet back height adjustment. 18 1/2"W x 18 1/2"D fabric upholstered seat has comfortable 3 3/4" thick cushioning for extended periods of sitting. Height adjustable armrests help reduce arm fatigue. 18-23"H seat height adjustment. The 5-blade base with dual wheel swivel casters provides stability and easy mobility. Easy Assembly. 1 year limited warranty.

Model
SC277436

HIGH BACK EXECUTIVE CHAIR WITH BREATHABLE LEATHER



Inspired by luxury sports car seats, this chair features a black high-grade leather with a network of tiny holes to permit air circulation for cool, dry comfort. Generous headrest, lumbar-support back and waterfall-edge seat add to the luxury. Pneumatic 19 to 22 1/2" seat height adjust. Tilt tension and back angle recline. 5-blade caster base. Seat: 21"W x 20"D x 3" thick. Back: 30"H. 1 Year Limited Warranty.

Model
SC248626

EXTRA VALUE ERGO CHAIR



Contoured built-in lumbar curve is 2 1/4" height adjustable to provide firm body support for increased employee productivity. 25° back recline infinitely adjusts for balanced posture. Pneumatic mechanism instantly changes seat height 16 1/2" to 21 1/2"H to help take pressure off legs. Back contoured cushion is 19"H x 16 1/2"W. Roomy 17"sq. seat with firm 2" foam cushion. Plastic shell back for long life. Comfortable 12"W x 8"H loop arms adjust 1" in/out. Easy assembly. 1 Year Limited Warranty. Add fabric color suffix to model number: Black (BK), Blue (BL), Burgundy (BY) or Gray (GY).

BIG & TALL MESH CHAIR

Big & Tall Mesh Ergonomic Chair has heavy duty construction that allows it to support users up to 450 lbs. Breathable mesh back and thickly padded black mesh fabric seat for added comfort. Sturdy aluminum base has an attractive gunmetal finish and five dual wheel casters for easy mobility. 21 5/8"W x 19 5/8"D seat and 22 3/4"W x 27 1/8"H back. 18 1/2" to 21 1/4"H pneumatic seat height adjustment. Easy Assembly. 1 Year Limited Warranty.

Model
SC277514



EXECUTIVE CHAIR

Comfort and Value

BLACK LEATHER AND FABRIC UPHOLSTERY

One-touch pneumatic 17"-22" height adjustment for personal positioning. Waterfall edge seat enhances leg circulation. 3" thick tufted seat and back for extra comfort. Seat 20¹/₂"W x 18⁷/₈"D. Back 20"W x 23⁷/₈"H. Sturdy five blade base with casters. Assembles in minutes. 1 Year Limited Warranty. Add suffix to fabric model no.: (BK) Black, (BL) Blue, (BY) Burgundy or (GY) Gray.



ONE-TOUCH
HEIGHT
ADJUSTMENT

LEATHER



BLACK
(BK)



BURGUNDY
(BY)



GRAY
(GY)



BLUE
(BL)

FABRICS AVAILABLE IN:

FABRIC



Description	Model
Black Leather Fabric	SC238558 SC238557

BIG & TALL CONTOURED OFFICE CHAIR



LEATHER



FABRIC



TILT-
TENSION
CONTROL

ONE-TOUCH
HEIGHT
ADJUSTMENT

This chair accommodates big and tall users in complete comfort. The extra plush 3¹/₂" thick seat and 2¹/₂" thick back cushions feature deep contours to fit posture naturally. Tilt lock and tension control provide optimal working position. Adjustable armrests reduce shoulder tension. Upholstered in heavy duty fabric or quality black leather. Seat: 22"W x 21"D x 18-22"H with pneumatic height adjustment. Back: 22"W x 26"H. 5-blade aluminum based finished in metallic titanium paint and includes heavy duty casters. 450 lb. capacity. 1 Year Limited Warranty.

Description	Model
Fabric	SC240123BK
Leather	SC240124

FULL SIZE EXECUTIVE CHAIR



250 lb.
capacity

BLACK
FABRIC

ONE-TOUCH
HEIGHT
ADJUSTMENT



These roomy chairs provide extra comfort at an affordable price. Hard-wearing acrylic fabric over soothing, form fitting 3" thick foam cushions. Large 23¹/₂"W x 20¹/₂"D seat and 23¹/₂"W x 27"H back with 11³/₄"W headrest. Pneumatic 19"-23¹/₂" seat height adjustment. 250 lb. capacity. 27"W five blade metal base with casters for stability. Easy assembly. 1 Year Limited Warranty.

Description	Black	Gray
Fabric	SC277425BK	SC277425GY

PARAMOUNT® MESH CHAIR WITH FLIP-UP ARMS



FLIP-UP
ARMS



BACK VIEW



FOLD-AWAY
ARMS



FINGER TIP
MECHANISM



STURDY
5 BLADE
CASTER
BASE

ADJUSTABLE
SEAT HEIGHT
FROM
18³/₄"-22¹/₄"

Chair offers a mesh back with a 4" molded foam fabric upholstered seat. Seat: 19"W x 18"D. Back: 17"W x 19¹/₄"H. Features an ergonomic design, multi-function seat adjustments with wire controlled mechanisms and a sliding seat. Flip-up armrests offer 7-way adjustments. 1 Year Limited Warranty. Easy Assembly.

Model
SC242119

MULTIFUNCTION PREMIUM MESH CHAIRS

Mesh back offers elastic, breathable comfort. Plastic trim back for long life. Built-in lumbar support provides added back support. Height adjustable armrests help reduce arm fatigue. Features independent back and seat angle adjustment, tilt lock, tilt tension control and pneumatic seat height adjustment. Stable 5-blade nylon base includes dual wheel swivel casters for easy mobility. Back measures 19³/₄"W x 23¹/₂"H. **Mesh Seat** features a breathable mesh seat with plastic trim. 17-20¹/₂" pneumatic height adjustment. Seat measures 20"W x 18¹/₂"D. **Fabric & Leather Upholstered Seat** have 3¹/₂" thick comfort cushioning. 17¹/₂"-21" pneumatic height adjustment. Seat measures 19¹/₂"W x 18³/₄"D. **Optional Vinyl Padded Headrest** provides head and neck support. Easy Assembly. 1 Year Limited Warranty.

OPTIONAL HEADREST



ADJUSTABLE ARMREST



Seat	Model
Fabric	SC248623
Leather	SC249051
Mesh	SC248622
Headrest	SC248625

ULTRA CUSHIONED LEATHER CHAIR



This beautiful office chair is priced to put pillow top luxury in every work day. Genuine black leather upholstered chair, including padded armrests. 4" thick contoured seat and back padding for added support. Tilt lock, tilt tension and pneumatic height adjustment personalize fit. 5 blade nylon carpet caster base. Pneumatic 20-23¹/₂" seat height adjust. Seat: 21¹/₂"W x 22"D. Back is 21¹/₂"W x 26¹/₂"H. Easy assembly. 1 Year Limited Warranty.

Model
SC277423

EXECUTIVE SEATING with Flip-Up Armrests Position Your Chair Closer to Your Desk

Luxurious executive chairs feature flip-up armrests for close positioning at the desk or conference table. Choose durable fabric or fine leather - all with padded armrests. All models have tilt lock and tension controls. Pneumatic 18¹/₂-22¹/₄" seat height adjustment and generous 29³/₄"H x 21"W lumbar-support back. Seat measures 19³/₄"D x 21"W. 4" thick foam cushions. 5 blade plastic base with casters. Easy assembly. 1 Year Limited Warranty.



ONE-TOUCH HEIGHT ADJUSTMENT



Seat Upholstery	Model
Black Fabric	SC277491
Black Leather	SC277492

01-800-467-0529

chproductos.com

115

THE SYNCHRO CHAIR Choose Fabric or Leather Upholstery

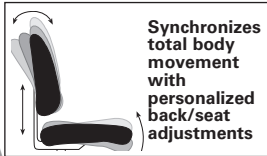

Fully adjustable seat height and angle help ensure that the body is kept in an ergonomically balanced position. Roomy 18" sq. seat has extra thick 3 1/2" padding that is covered in long lasting, durable acrylic or black leather upholstery for an attractive look. Waterfall contoured seat helps to reduce stress on knees and helps ensure proper circulation. Contoured back provides lumbar support and encourages proper posture. Poly-shell back and seat base won't crack, rip, chip or dent. 18"-23" seat height adjustment. **Task** features a 17 1/2" sq. back and **Operator** features a 17 1/2" W x 19"H back. Available with height adjustable T-arms to align arms and wrist correctly for computer work. Arms also adjust side-to-side. Polypropylene, five-blade, base with 2" dual carpet casters provides easy mobility. Easy assembly. 2 Year Limited Warranty.

FABRIC OPERATOR W/ADJUSTABLE ARMS

7-WAY ADJUSTABLE
SC506797



Description	†FABRIC
Task Chair	SC594137
Task w/Arms	SC594138
Operator	SC594139
Operator w/Arms	SC594140
†Add color suffix: Black (BK), Blue (BL), Burgundy (BY) or Gray (GY).	

Description	LEATHER
Task Chair	SC506794
Task w/Arms	SC506795
Operator	SC506796
Operator w/Arms	SC506797



5-WAY ADJUSTABLE ERGO EXECUTIVE CHAIR

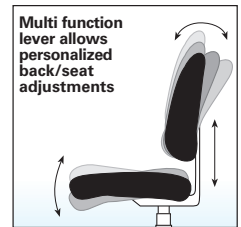

Helps increase productivity and energy level throughout the day. Oversized, thick 5" foam cushioning covered with durable Scotchgard™ nylon fabric. Luxuriously comfortable plush foam waterfall design seat and back are ergonomically constructed to prevent back and leg fatigue. Simultaneous adjustment of back angle and seat tilt with Synchro control for personalized positioning. Customize back height for proper lumbar support. 17"-22" pneumatic seat height adjustment. Arms are side-to-side adjustable and are covered in resilient textured urethane over steel. Five blade base with dual wheel casters for smooth mobility. Easy assembly. 2 Year Limited Warranty.

Description	Seat Size W" x D"	Back Size W" x H"	Burgundy	Gray	Black
High Back	20 1/2 x 20	19 1/2 x 26	SC506331BY	SC506331GY	SC506331BK
Low Back	20 1/2 x 20	19 1/2 x 22	SC506332BY	SC506332GY	SC506332BK

8-WAY HIGH-BACK AND MID-BACK ERGONOMIC CHAIRS



HIGH-BACK LEATHER
SC277427



Online Video & Photos



POLISHED ALUMINUM BASE
HIGH-BACK FABRIC
SC277428

27"H HIGH-BACK



MID-BACK FABRIC
SC506574BY



EXTENDED SERVICE PLAN

20"H MID-BACK



MID-BACK LEATHER
SC506399

8 ADJUSTABLE POSITIONS:

1. Tilt Tension Adjustment
2. Forward Tilt Control
3. Seat/Back Angle Adjustment
4. Pneumatic Seat Height Adjustment
5. Free Floating Back Angle Adjustment
6. 3" Height Adjustable Arms
7. 2" Width Adjustable Arms
8. Back Height Adjustment

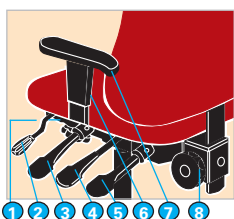

Ultra adjustable chairs allow personalized positioning for day long comfort. Extra thick 3 1/2" padding is covered in either long lasting, genuine black leather or durable fabric upholstery for an attractive look. Waterfall contoured design helps reduce stress on your knees. Contoured back provides lumbar support. **Mid-Back chair** has 20"W x 19 1/2"D seat and 19 1/2"W x 20"H back. Optional height adjustable T-arms also adjust side-to-side. 15 1/2"-19 1/2" pneumatic height adjustment. **High-Back chair** has 23 1/2"W x 20 1/2"D seat and 23 1/2"W x 27"H back. Standard height adjustable T-arms also adjust side to side. 19 to 23 1/2" pneumatic seat height adjustment. Polished aluminum base with 2" dual wheel carpet casters provides easy mobility. **High-Back** available in black fabric or leather. Easy assembly. 1 Year Limited Warranty. *Suffix fabric color to mid-back model no: Black (BK), Burgundy (BY) or Gray (GY).

FABRIC

Description	Model
Mid-Back w/out arms	SC506574*
Mid-Back with arms	SC506575*
High-Back with arms	SC277428

LEATHER

Description	Model
Mid-Back w/out arms	SC506398
Mid-Back with arms	SC506399
High Back with arms	SC277427

8-WAY ADJUSTABLE EXECUTIVE CHAIR

This fabric upholstered chair is fully adjustable for improved ergonomic support. High-back design cushions your head, neck and shoulders. 5" thick foam is built into the 21"W x 20"D seat. Backmeasures 20"W x 25"H. Features full-function ergonomic controls for seat/back angle and independent back angle adjustment. Includes height adjustable back seat for precise lumbar support. 19-23" pneumatic seat height adjustment. Height and side-to-side adjustable armrests help prevent arm fatigue. Includes stable 5 blade polyurethane base and dual wheel swivel casters. Easy Assembly. 1 Year Limited Warranty. Specify fabric color suffix: Black (BK), Blue (BL), Gray (GY), or Burgundy (BY).



Model
SC250575

SC250575BL



Online Video & Photos



EXTENDED SERVICE PLAN



8-WAY ADJUSTABLE

8-WAY LEATHER HIGH BACK CHAIR



EXTENDED SERVICE PLAN

ADJUSTABLE ARMS



SC506573

Model
SC506573

Genuine leather upholstered chair is fully adjustable for improved ergonomic support. High-back design cushions your head, neck and shoulders. 5" thick foam is built into the 21"W x 20"D seat and 20"W x 25"H back. Features full function ergonomic controls for adjusting either seat/back angle or back angle independently. Back of seat adjusts for precise lumbar support. 19" - 23" pneumatic seat height adjustment. Height and side-to-side adjustable arms help prevent arm fatigue. Includes 5-pronged polyurethane base and dual wheel casters. Black. Assembles easily. 1 Year Limited Warranty.

01-800-467-0529

chproductos.com

117

COORDINATED EXECUTIVE LEATHER SEATING



HIGH BACK



MID BACK



VISITOR



Contoured seat and back provide superior lumbar support. **High Back** and **Mid Back** have locking back tilt mechanism with tension control, allowing users of different body types to use a single chair. Feature 18-22" pneumatic seat height adjustment and heavy duty wheel casters. **High Back** model has 4" thick 20¹/₄"W x 30¹/₂"H back and a 20"W x 20"D seat. **Mid Back** and **Visitor** models have a 20"W x 22¹/₂"H back and a 20"W x 20"D seat. Black leather 4" thick cushion on all styles. 1 Year Limited Warranty.

Model	Description
SC607887BK	High back
SC607888BK	Mid-back
SC607889BK	Visitor

CONTOURED FABRIC UPHOLSTERED CHAIR



Deeply tufted, black acrylic fabric upholstered chair with 4" thick cushioning for superior comfort. Seat measures 20"W x 20"D. Back measures 19"W x 20"H. Waterfall edge seat helps improve leg circulation. 15-19" pneumatic seat height adjustment. Armrests are covered in textured urethane over steel. Stable 5-blade base includes dual wheel swivel casters. Easy assembly. 1 Year Limited Warranty.

Model
SC238563BK

CLASSIC LEATHER MID-BACK CHAIR



ONE-TOUCH HEIGHT ADJUSTMENT

High grain, genuine black leather upholstered chair features swivel, tilt lock control, and pneumatic height adjustment. Polyurethane arms provide added support. Back measures 5" thick x 20"W x 22"H. Seat measures 20"W x 19¹/₂"D. Stable 5-blade base include dual wheel swivel casters. Easy assembly. 1 Year Limited Warranty.

Model
SC607892

SADDLE STITCHED LEATHER CHAIR



PADDED HEADREST



SADDLE STITCHED STYLING

Quality black leather upholstered chair with 4" thick cushions are deeply contoured and have contrasting topstitching. Leather padded curved armrests. Polished metal 5-blade base. Ergonomic adjustments include 19 to 23¹/₂" pneumatic height adjustment, tilt tension and angle adjustments. Seat measures 22³/₄"W x 19"D. Back has padded headrest and measures 21³/₄"W x 32"H. 1 Year Limited Warranty.

Model
SC240121BK

PRODUCTIVITY COORDINATED SEATING



SC607893GY



ONE TOUCH SEAT HEIGHT ADJUSTMENT

SC607894BK

This contemporary seating provides built-in lumbar support for improved posture. Features commercial grade stain resistant upholstery with 3 1/2" thick foam cushioning for firm support. Pneumatic 18"-22" seat height adjustment provides personal positioning. Extra long black plastic armrests help prevent arm fatigue. Adjustable back tilt tension and upright lock position control allows you to instantly adjust to the task at hand. **High Back** has 20"W x 18 1/2"D seat and 20"W x 24 1/2"H back; **Mid Back** has 20"W x 18 1/2"D seat, with a 20"W x 22"H back. Five blade plastic base with dual casters for easy mobility. Easy assembly. 1 Year Limited Warranty.

Description	Fabric Color	Model
Mid Back	Black	SC607894BK
High Back	Gray	SC607893GY

ERGONOMIC FABRIC UPHOLSTERED SEATING



MID BACK SC607896GY



HIGH BACK SC607895GY

Instantly adjust seat from 16"-20" high. Adjust back recline tension or lock in upright position. High-density foam cushions are covered in durable 100% olefin upholstery for years of service. All have 20"W x 18 1/2"D seat. **Mid Back** has 20 3/4"W x 17 1/2"H back; **High Back** has 20 3/4"W x 26"H back. 1 Year Limited Warranty.

Description	Gray	Navy
Mid Back	SC607896GY	SC607896NV
High Back	SC607895GY	SC607895NV

THE EZ Form II SEATING



Ergonomically contoured **EZForm II** helps reduce chair-related dis-comfort such as lower back pain and circulatory problems. Soft 100% nylon fabric with 4 1/2" thick padded seat and back cushions provide excellent support. Seat measures 20 3/4"W x 21"D. Back measures 20 1/2"W x 25"H back. Five blade molded base has smooth-rolling, non-marring dual disc casters for easy mobility. Comfortable upholstered foam padded armrests. Easy assembly. 1 Year Limited Warranty. Model **SC506738BK**



FINGERTIP HEIGHT ADJUSTMENT

LEATHER TASK SEATING

Mid back genuine black leather task seating styling with firm lumbar support and extra large cushioned 19 1/4"W x 19 1/2"D seat and 20"W x 23"H back. 3" thick cushion inset and back. Optional durable molded polyurethane loop or 3-way adjustable armrests. 19"-22 1/2" pneumatic height adjustable seat with simple fingertip control. Five blade nylon base with dual casters for easy movement. 6 Year Limited Warranty.

Description	Model
Armless	SC773174
Loop Arms	SC773175
3-Way Arms	SC773176



SC773176

MULTIFUNCTION MESH CHAIR



6 COMFORT SETTINGS:

- Seat/Back tilt adjustment
- Pneumatic seat height adjustment
- Back angle adjustment
- Tilt tension adjustment
- 3" height adjustable arms
- 4" back height adjustment

This 6-way adjustable task chair provides ultimate comfort, ensuring that the body is kept in an ergonomically balanced position. Features 4" thick cushioned seat & back with advanced airflow black mesh fabric upholstery for breathable comfort. 21 1/4"W x 23"D seat and 21 3/4"W x 23"H back. 17-21" pneumatic seat height adjustment. Padded armrests are contoured with 3" height adjustment. Mesh chair also includes back/seat tilt and back angle adjustment levers along with 4" adjustable back height knob for quick and easy ergonomic comfort. Stable 24"W 5-blade base includes hooded dual-wheel nylon casters for easy mobility. Easy assembly. 1 Year Limited Warranty. Model **SC240147**

PLAN, DESIGN AND BUILD PARAMOUNT®

Office Solutions Made Easy. Order our pre-configured stations as is or mix-and-match pieces to support your needs. We can help you build any configuration, whether it is one cubicle or an entire office space.



Paramount® 4-Person Workstation Includes:

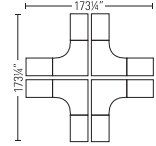

Qty.	Model	Description
4	SC694767WNBL	48"W x 47 1/2"H Deluxe Panels with Windows & Raceway, Blue
4	SC694766WNBL	36"W x 47 1/2"H Deluxe Panels with Windows & Raceway, Blue
8	SC694765WNBL	24"W x 47 1/2"H Deluxe Panels with Windows & Raceway, Blue
4	SC248993GY	48" Corner Workstation, Gray
8	SC249012GY	36"W Desks, Gray
4	SC240272	3 Drawer Pedestals - Box/Box/File
2	SC240271	2 Drawer Pedestal - File/File
4	SC277436	Mid Back Mesh Chair
4	SC238644	Straight Connectors
8	SC249065	End Caps
4	SC248990N	3Way Connectors for 42"H Panels
1	SC238646	4Way Connector

Model
SC695066 Complete Workstation

Paramount® Manager Station Includes:

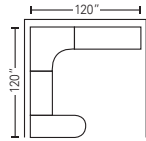

Qty.	Model	Description
4	SC277566NGY	60"W x 72 1/2"H Deluxe Panels & Raceway, Gray
2	SC694705WNGY	60"W x 72"H Deluxe Panels with Windows & Raceway, Gray
1	SC248993CH	48" Corner Workstation - Cherry
1	SC240266CH	72" Desk - Cherry
1	SC240279CH	48" Desk - Cherry
1	SC240270CH	60" Peninsula - Cherry
1	SC240261	60" Shelf
1	SC240278	60" Overhead Cabinet
1	SC248986	Lateral File Cabinet (not-shown)
1	SC240272	3 Drawer Pedestal
1	SC248626	Office Chair, Leather High Back
1	SC250785	Reception Chair
3	SC238644	Straight Connectors
2	SC238641N	90 Degree Corner Connectors for 72"H Panel

Model
SC695067 Complete Workstation



CHAIRS SOLD
SEPARATELY

Paramount® Single Deluxe Cubicle Includes:

Qty.	Model	Description
7	SC277546NGY	36"W x 46"H Deluxe Panel with Raceway, Gray
1	SC277564NGY	60"W x 46"H Deluxe Panel with Raceway, Gray
1	SC240266CH	72" Desk, Cherry
1	SC248917CH	36"W Left Hand Return Table, Cherry
1	SC248994CH	72" Peninsula, Cherry
2	SC240272	3 Drawer Pedestal Box/Box/File

Model
**SC695069
Complete
Workstation**

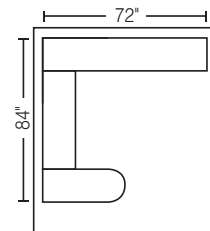

PRE-CONFIGURED OFFICE WORKSTATIONS



Paramount® Single Deluxe Cubicle w/Windows Includes:

Qty.	Model	Description
2	SC694767WNBL	48"W x 47 1/2"H Deluxe Panels with Windows & Raceway, Blue
2	SC694766WNBL	36"W x 47 1/2"H Deluxe Panels with Windows & Raceway, Blue
2	SC694765WNBL	24"W x 47 1/2"H Deluxe Panels with Windows & Raceway, Blue
1	SC248993GY	48" Corner Workstation, Gray
2	SC249012GY	36"W Desks, Gray
1	SC240272	3 Drawer Pedestals, Box/Box/File
1	SC240271	2 Drawer Pedestal
1	SC277436	Mid Back Mesh Chair
2	SC238644	Straight Connectors
2	SC249065	End Caps
3	SC248989N	90 degree connectors for 42"H Panels

Model

SC695068 Complete Workstation

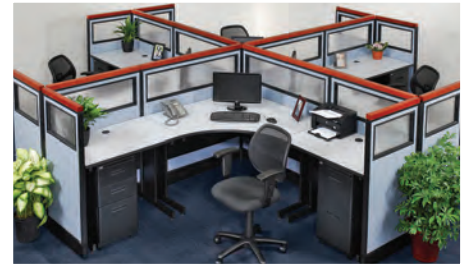
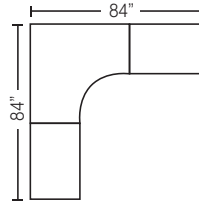

Put 4 Single Cubicles together to make this configuration. See opposite page for details

Paramount® Call Center Starter Includes:

Qty.	Model	Description
1	SC238637GY	48"W x 60"H Office Partition Panel, Gray
2	SC240225GY	48"W x 42"H Office Partition Panel, Gray
2	SC240255	High-Low Corner 90° Connector Kit

Model

SC240313GY Complete Workstation

ADD-ON (240314GY) INCLUDES:

1	SC238637GY	48"W x 60"H Office Partition Panel, Gray
1	SC240225GY	48"W x 42"H Office Partition Panel, Gray
1	SC238644	Straight Connector Kit
1	SC240255	High-Low Corner 90° Connector Kit

Model

SC240314GY Complete Workstation



OPTIONAL CHAIRS SOLD SEPARATELY

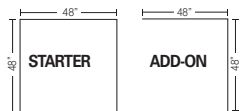

*Back Panels also available in 60"W

FREE Space Planning Help Available

Let us come up with a customized design that's right for you.
Get started by calling 1-888-277-6995
or emailing sales@globalindustrial.com

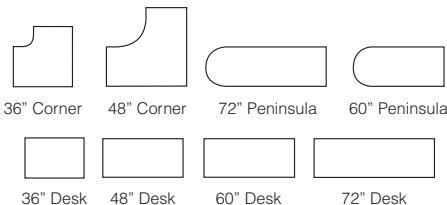

Let us help take your office idea from conception to reality!

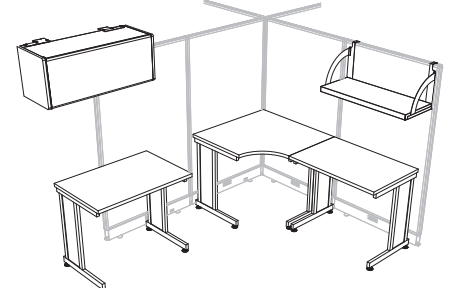
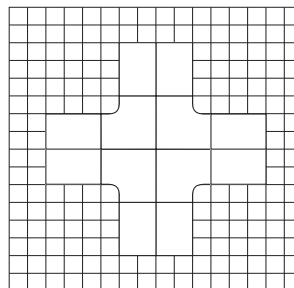

01-800-467-0529

chproductos.com

121

PARAMOUNT® OFFICE PARTITIONS

Durable, attractive office partition panels and furniture can be used to create private spaces, cubicles, reception stations, call centers and more! Quick to install and easy to reconfigure using **Steel Connectors** (sold separately). **Standard versions** include 1¾" thick panels upholstered in fabric to offer a tackable surface that meets the California 117 flammability standard. Panel trim is finished with self-extinguishing extruded polymer to offer optimum safety and rigidity. Partitions include adjustable leveling feet that are ideal for uneven surfaces. **Deluxe versions** include wood accent cap with cherry finish on panel top. Add 1½" to panel height*. Panels with either a partial or full **window** feature a 5mm thick translucent polycarbonate window, which allows light into cubicle space while still maintaining privacy. **Whiteboard panels** feature full magnetic whiteboards on both sides. Fabric panels available in **Gray** or **Blue** upholstery. 1 Year Limited Warranty.

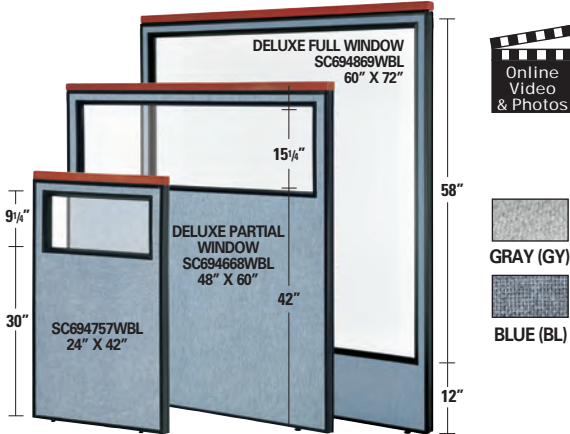

Office Partition Panel with Whiteboard, 36-1/4\"/>

MAGNETIC DOUBLE SIDED WHITEBOARD SC694926B

FREE SPACE PLANNING HELP AVAILABLE!
Get started by calling 1-888-277-6995 or email sales@globalindustrial.com today!

CONNECTORS FOR SAME HEIGHT PANELS

Model	Description
SC238644	Straight Connector Kit
SC248989	Corner 90° Kit For 42\"/>

W"x H"	STANDARD Model	DELUXE Model	STANDARD W/PARTIAL WINDOW Model	DELUXE W/PARTIAL WINDOW Model	STANDARD W/FULL WINDOW Model	DELUXE W/FULL WINDOW Model	WHITE BOARD STANDARD Model	WHITE BOARD DELUXE Model
24 x 42	SC277660	SC277676	SC694753W	SC694757W	---	---	---	---
24 x 60	SC277661	SC277677	SC694658W	SC694666W	---	---	---	---
24 x 72	SC277662	SC277678	SC694662W	SC694670W	---	---	---	---
36 x 42	SC240224	SC277525	SC694754W	SC694758W	---	---	---	---
36 x 60	SC238635	SC277526	SC694659W	SC694667W	SC694862W	SC694866W	SC694926B	SC694930B
36 x 72	SC238636	SC277527	SC694663W	SC694671W	SC694863W	SC694867W	SC694927B	SC694931B
48 x 42	SC240225	SC277528	SC694755W	SC694759W	---	---	---	---
48 x 60	SC238637	SC277529	SC694660W	SC694668W	---	---	SC694928B	SC694932B
48 x 72	SC238638	SC277530	SC694664W	SC694672W	---	---	SC694929B	SC694933B
60 x 42	SC240226	SC277531	SC694756W	SC694760W	---	---	---	---
60 x 60	SC238639	SC277532	SC694661W	SC694669W	SC694864W	SC694868W	---	---
60 x 72	SC238640	SC277533	SC694665W	SC694673W	SC694865W	SC694869W	---	---

Add color suffix: Gray (GY) or Blue (BL).

*Wood accent cap is non-weight bearing and is not intended for hanging objects

Making The Connection

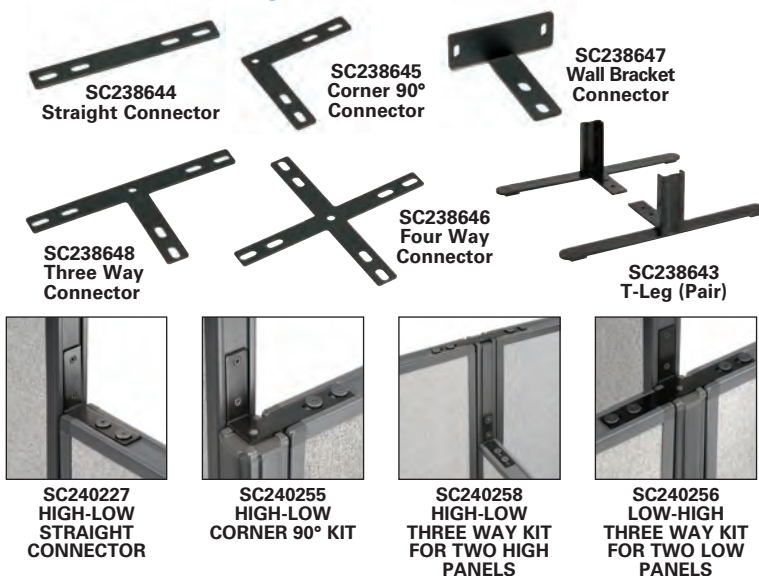

Quick & Easy...1,2,3 Assembly



CONNECTORS FOR MULTI-HEIGHT PANELS

Model	Description
SC240227	High-Low Straight Connector
SC240255	High-Low Corner 90° Kit For 42\"/>

CONNECTORS FOR SAME HEIGHT PANELS

Model	Description
SC238644	Straight Connector Kit
SC248989	Corner 90° Kit For 42\"/>

PARAMOUNT® OFFICE PARTITIONS WITH MODULAR WIRE MANAGEMENT RACEWAY

Raceway partitions create private offices and cubicles with built-in power options for computers and other electric equipment. Raceways provide convenient access for data cables & electrical wiring to keep office spaces clean and clear of visible wires. Panel is flame retardant to meet California 117 flammability standard. 13/4" thick fabric upholstered panels feature an interior engineered wood (MDF) frame and honeycomb core covered with heavy tackable liner for structural strength. 4"H charcoal powder coated steel raceways include UL approved modular electric components and cable management openings for phone & data connectors. Removable, hinged raceway covers allow easy wiring access. Includes adjustable leveling feet for uneven surfaces. 1 Year Limited Warranty. See our website for matching furniture and wood accent cap options. All panel models available with window or whiteboard option.

Free Space Planning
Available. Call 1-888-277-6995
or email
sales@globalindustrial.com



GRAY (GY)



BLUE (BL)



Online
Video
& Photos



PANEL WITH ELECTRIC RACEWAY INCLUDES DOUBLE SIDED POWER BOXES



STEP 1 – PARTITIONS

Electric and non-electric panels can be connected together to place power where you need it. **Non-Electric Panels** include a basic raceway without cabling. **Pass-Thru Panels** include raceways with cables to connect to panels. **Panel with Electric Raceways** include built-in double-sided power box, four circuit 1 receptacles and modular cables. Each power box can accept up to 6 receptacles; 3 per side (additional Receptacles sold separately). Use included **Blanks** to cover unused openings. **36"W Electric Panel** includes one double-sided power box. **48" & 60"W Electric Panels** include 2 double-sided power boxes.

W" x H"	Non-Electric Panel Model	Pass-Thru Panel Model	Panel With Electric Model	Power Boxes	Blanks
24 x 46	SC277660N	SC277660P	---	---	---
36 x 46	SC240224N	SC240224P	SC240224E	1	2
48 x 46	SC240225N	SC240225P	SC240225E	2	8
60 x 46	SC240226N	SC240226P	SC240226E	2	8
24 x 64	SC277661N	SC277661P	---	---	---
36 x 64	SC238635N	SC238635P	SC238635E	1	2
48 x 64	SC238637N	SC238637P	SC238637E	2	8
60 x 64	SC238639N	SC238639P	SC238639E	2	8
24 x 76	SC277662N	SC277662P	---	---	---
36 x 76	SC238636N	SC238636P	SC238636E	1	2
48 x 76	SC238638N	SC238638P	SC238638E	2	8
60 x 76	SC238640N	SC238640P	SC238640E	2	8

Add color suffix: Gray (GY) or Blue (BL).



PASS-THRU CABLE



SINGLE CIRCUIT
PLUG IN CABLE

MULTI CIRCUIT
STARTER CABLE

STEP 3 – CABLES AND RECEPTACLES

Starter Cable (Multiple Circuits, 80 receptacles max.) must be installed to a junction box for a power source. Cable pre-wired for 1-4 circuits. **Plug In Cable** (Single Circuit) easily plugs into existing wall outlets for power. Choice of 15 AMP (16 receptacles max.) or 20 AMP (20 receptacles max.) 115 volt plug. Additional circuit 1, 2, 3 (Isolated Ground) & 4 receptacles available in packages of four. **Receptacle Removal Tool** is required when removing receptacles from power box.



15AMP
PLUG



20AMP
PLUG

Model	Description
SC249054	Starter Cable 72"
SC249055	Starter Cable 144"
SC249056	Plug In Cable 72" 15AMP
SC249066	Plug In Cable 72" 20AMP
SC249057	Extended/Corner Cable
SC249061	Circuit 1 Receptacle (Pkg. 4)
SC249062	Circuit 2 Receptacle (Pkg. 4)
SC249063	Isolated Ground Receptacle (Pkg. 4)
SC249064	Circuit 4 Receptacle (Pkg. 4)
SC249053	Receptacle Removal Tool



RECEPTACLE
REMOVAL TOOL



RECEPTACLES 1, 2, 3(IG) & 4

STEP 2 – CONNECTOR

Steel connectors join multiple partitions together and create various configurations. Use **connectors with 1 Extended/Corner Cable** to complete a 90° turn or span intersection. Additional **Extended/Corner Cables** available separately (See Step 3).

FOR SAME HEIGHT PANELS

Description	Without Cable	With 1 Extended/Corner Cable
Straight Connector Kit	SC238644N	---
Corner 90° Kit For 46"H Panel	SC248989N	SC248989P
Corner 90° Kit For 64"H Panel	SC238645N	SC238645P
Corner 90° Kit For 76"H Panel	SC238641N	SC238641P
Three Way Kit For 46"H Panel	SC248990N	SC248990P
Three Way Kit For 64"H Panel	SC238648N	SC238648P
Three Way Kit For 76"H Panel	SC238642N	SC238642P
Four Way Connector Kit	SC238646N	SC238646P
Wall Connector Kit	SC238647N	---
End Base Cap (to finish panel end runs)	SC249065	---

FOR MULTI-HEIGHT PANELS

Description	Without Cable	With 1 Extended/Corner Cable
High-Low Straight Connector	SC240227N	---
High-Low Corner 90° Kit For 46" Low Panel	SC240255N	SC240255P
High-Low Corner 90° Kit For 64" Low Panel	SC240253N	SC240253P
High-Low Three Way Kit For Two 64" High Panel	SC240258N	SC240258P
High-Low Three Way Kit For Two 76" High Panel	SC240257N	SC240257P
Low-High Three Way Kit For Two 46" Low Panel	SC240256N	SC240256P
Low-High Three Way Kit For Two 64" Low Panel	SC240254N	SC240254P



REMOVABLE, HINGED
RACEWAY COVER
ALLOWS EASY ACCESS
TO RECEPTACLES AND
CABLES

CABLE MANAGEMENT
OPENINGS FOR PHONE
& DATA CONNECTORS
(CABLES & CONNECTORS
NOT INCLUDED)

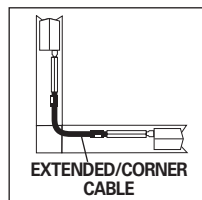

CORNER 90° CONNECTION*

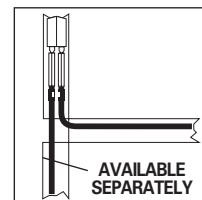

THREE WAY CONNECTION*

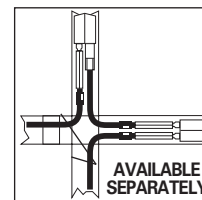

FOUR WAY CONNECTION*

*Connector kit includes 1 Extended/Corner Cable. Order additional Extended/Corner Cables as needed.

PARAMOUNT® MOBILE OFFICE PARTITIONS & ROOM DIVIDERS



Mobile Partition Panels allow you to divide a work area in any office or commercial setting. Mobile Panels sit atop steel T-legs on sturdy 3" swivel casters (all locking) that provide full mobility and allow easy transport from area to area. Panel trims are finished with self-extinguishing extruded polymer that offer optimum safety and rigidity. Each **Fabric Panel** is upholstered on both sides with tackable, flame retardant fabric that meets the California 117 flammability standard. Panels are 1 3/4" thick and feature an interior engineered wood (MDF) frame and honeycomb core for structural strength and support. **Deluxe Panels** feature a wood cap trim with cherry finish. **Mobile Panels** with Windows include a 5mm thick translucent polycarbonate inset which allows light in while still maintaining privacy, bringing an elegant and upscale look to any office space. The panels are available with partial window or full windows. **Mobile Whiteboards** are multi-functional and can double as portable working space or a room divider. This panel is easily transported from area to area making it perfect for collaborative teamwork. Painted Steel surface allows you to write smoothly with no ghosting. Use heavy duty magnets to hang notes, ideas and reminders. All mobile panels coordinate beautifully with Paramount's complete line of office partition panels. 1 Year Limited Warranty. Add color suffix Gray (GY) or Blue (BL).

W x H	STANDARD Model	DELUXE Model	STANDARD W/ PARTIAL WINDOW Model	DELUXE W/ PARTIAL WINDOW Model	STANDARD W/ FULL WINDOW Model	DELUXE W/ FULL WINDOW Model	WHITEBOARD STANDARD Model	WHITEBOARD DELUXE Model
24 x 42	SC694952M	SC694964M	SC694976M	SC694988M	---	---	---	---
24 x 60	SC694953M	SC694965M	SC694977M	SC694989M	---	---	---	---
24 x 72	SC694954M	SC694966M	SC694978M	SC694990M	---	---	---	---
36 x 42	SC694955M	SC694967M	SC694979M	SC694991M	---	---	---	---
36 x 60	SC694956M	SC694968M	SC694980M	SC694992M	SC695000M	SC695004M	SC694942MB	SC694946MB
36 x 72	SC694957M	SC694969M	SC694981M	SC694993M	SC695001M	SC695005M	SC694943MB	SC694947MB
48 x 42	SC694958M	SC694970M	SC694982M	SC694994M	---	---	---	---
48 x 60	SC694959M	SC694971M	SC694983M	SC694995M	---	---	SC694944MB	SC694948MB
48 x 72	SC694960M	SC694972M	SC694984M	SC694996M	---	---	SC694945MB	SC694949MB
60 x 42	SC694961M	SC694973M	SC694985M	SC694997M	---	---	---	---
60 x 60	SC694962M	SC694974M	SC694986M	SC694998M	SC695002M	SC695006M	---	---
60 x 72	SC694963M	SC694975M	SC694987M	SC694999M	SC695003M	SC695007M	---	---

PARAMOUNT® CORNER ROOM DIVIDERS



3-PANEL CORNER ROOM DIVIDER W/PARTIAL WINDOW



STANDARD 2-PANEL CORNER ROOM DIVIDER

Whether you need to contain noise, enclose an office desk or block off a copy machine, these room dividers will make it easy and affordable. All room dividers include steel T-legs, partition panels and all necessary hardware to build a 90 degree partition. Available in 2-panel or 3-panel configurations to meet your every need. All panels within the same configuration are the same size. **Fabric panel room**

dividers come with our standard panel in your choice of blue or gray color. Window room dividers include a translucent and polycarbonate window inset. **Room Dividers with Whiteboard** include 1 panel with a double sided, magnetic dry erase board, perfect for writing notes, sharing ideas and posting messages. 1 Year Limited Warranty. Add color suffix Gray (GY) or Blue (BL).

2-PANEL CORNER ROOM DIVIDER

	STANDARD Model	DELUXE Model	STANDARD W/ PARTIAL WINDOW Model	DELUXE W/ PARTIAL WINDOW Model	STANDARD W/FULL WINDOW Model	DELUXE W/ FULL WINDOW Model
24 x 42	SC695061	SC695064	SC695058	SC695055	---	---
24 x 60	SC695062	SC695065	SC695059	SC695056	---	---
24 x 72	SC695063	SC695071	SC695060	SC695057	---	---
36 x 42	SC695027	SC695072	SC695021	SC695013	---	---
36 x 60	SC695028	SC695073	SC695022	SC695014	SC695019	SC695011
36 x 72	SC695029	SC695074	SC695023	SC695015	SC695020	SC695012
48 x 42	SC695030	SC695075	SC695024	SC695016	SC695101	SC695096
48 x 60	SC695031	SC695076	SC695025	SC695017	SC695102	SC695097
48 x 72	SC695032	SC695077	SC695026	SC695018	---	---
60 x 42	SC695106	SC695156	SC695103	SC695098	---	---
60 x 60	SC695107	SC695157	SC695104	SC695099	---	---
60 x 72	SC695108	SC695158	SC695105	SC695100	---	---

3-PANEL CORNER ROOM DIVIDER

	STANDARD Model	DELUXE Model	STANDARD W/ PARTIAL WINDOW Model	DELUXE W/ PARTIAL WINDOW Model	STANDARD W/FULL WINDOW Model	DELUXE W/ FULL WINDOW Model
24 x 42	SC695093	SC695087	SC695090	SC695084	---	---
24 x 60	SC695094	SC695088	SC695091	SC695085	---	---
24 x 72	SC695095	SC695089	SC695092	SC695086	---	---
36 x 42	SC695049	SC695078	SC695043	SC695035	---	---
36 x 60	SC695050	SC695079	SC695044	SC695036	SC695041	SC695033
36 x 72	SC695051	SC695080	SC695045	SC695037	SC695042	SC695034
48 x 42	SC695052	SC695081	SC695046	SC695038	SC695114	SC695109
48 x 60	SC695053	SC695082	SC695047	SC695039	SC695115	SC695110
48 x 72	SC695054	SC695083	SC695048	SC695040	---	---
60 x 42	SC695119	SC695153	SC695116	SC695111	---	---
60 x 60	SC695120	SC695154	SC695117	SC695112	---	---
60 x 72	SC695121	SC695155	SC695118	SC695113	---	---

PARAMOUNT™ OFFICE RECEPTION STATIONS

Reception counters offer a convenient writing surface for guests and visitors while maintaining personnel privacy. Desktops include cable management openings and are made of 1" thick scratch resistant laminate. Tackable partition panels are flame retardant and measure 1¾" thick with an MDF frame and honeycomb core. Includes adjustable leveling feet that are ideal for uneven surfaces. Choose between **L-Shaped & U-Shaped** Reception Stations. Desktops available in Cherry or Gray finishes. Panels available in Gray and Blue fabric with or without translucent windows. 1 Year Limited Warranty.



SC694914WCB

WITHOUT WINDOWS					WITH WINDOWS				
Model	Top Finish	Panel Fabric	Shape	W"x H"	Model	Top Finish	Panel Fabric	Shape	W"x H"
SC249008CB	Cherry	Blue	U-Shaped	88 x 44	SC694902WCB	Cherry	Blue	U-Shaped	88 x 44
SC249008CG	Gray	Gray	U-Shaped	88 x 44	SC694902WCG	Gray	Gray	U-Shaped	88 x 44
SC249008GB	Gray	Blue	U-Shaped	88 x 44	SC694905WGB	Gray	Blue	U-Shaped	88 x 44
SC249008GG	Gray	Gray	U-Shaped	88 x 44	SC694905WGG	Gray	Gray	U-Shaped	88 x 44
SC249010GG	Gray	Gray	U-Shaped	124 x 44	SC694914WCB	Cherry	Blue	U-Shaped	124 x 44
SC249010CB	Cherry	Blue	U-Shaped	124 x 44	SC694914WCG	Gray	Blue	U-Shaped	124 x 44
SC249010GB	Gray	Blue	U-Shaped	124 x 44	SC694917WGB	Cherry	Gray	U-Shaped	124 x 44
SC249010CG	Cherry	Gray	U-Shaped	124 x 44	SC694917WCG	Gray	Gray	U-Shaped	124 x 44
SC249009CG	Cherry	Gray	L-Shaped	80 x 80	SC694908WCB	Cherry	Blue	L-Shaped	80 x 80
SC249009CB	Cherry	Blue	L-Shaped	80 x 80	SC694908WCG	Gray	Blue	L-Shaped	80 x 80
SC249009GB	Gray	Blue	L-Shaped	80 x 80	SC694911WGB	Cherry	Gray	L-Shaped	80 x 80
SC249009GG	Gray	Gray	L-Shaped	80 x 80	SC694911WCG	Gray	Gray	L-Shaped	80 x 80
SC249011GG	Gray	Gray	L-Shaped	116 x 80	SC694920WCB	Cherry	Blue	L-Shaped	116 x 80
SC249011CB	Cherry	Blue	L-Shaped	116 x 80	SC694920WCG	Gray	Blue	L-Shaped	116 x 80
SC249011GB	Gray	Blue	L-Shaped	116 x 80	SC694923WGB	Cherry	Gray	L-Shaped	116 x 80
SC249011CG	Cherry	Gray	L-Shaped	116 x 80	SC694923WCG	Gray	Gray	L-Shaped	116 x 80



SC249011GB

PARAMOUNT™ FREESTANDING OFFICE PARTITIONS

Freestanding Office Partitions are made with steel T-legs to ensure stability and allow easy rearranging. Panels are made using 1¾" thick fabric upholstery with an MDF frame and honeycomb core covered with heavy tackable liner. Panel trim is finished with self-extinguishing extruded polymer for optimum safety and rigidity. Panels are flame-retardant to meet the California 117 flammability standard. **Deluxe** models feature a wood cap trim with cherry finish. Both **Standard** and **Deluxe** models are available with **Full Window** or **Partial Window**. Windows are made of translucent polycarbonate with a wave pattern to allow light penetration while still maintaining privacy. **Add color suffix: Gray (GY) or Blue (BL).**



STANDARD

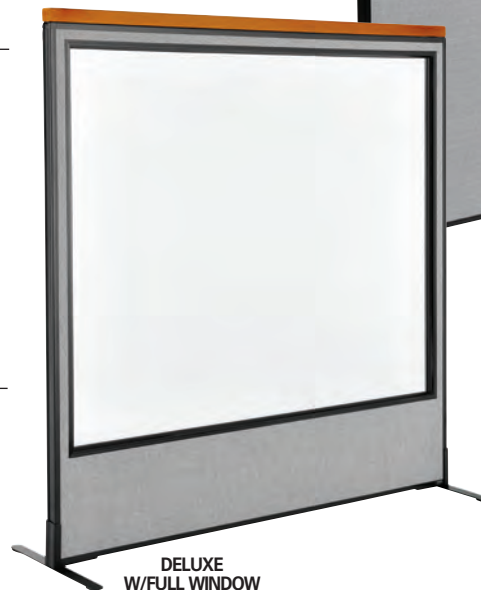

DELUXE W/FULL WINDOW



DURABLE STEEL T-LEGS

W"x H"	DELUXE W/ PARTIAL WINDOW Model	STANDARD W/ FULL WINDOW Model	DELUXE W/ FULL WINDOW Model
24 x 42	SC694761WF	--	--
24 x 60	SC694682WF	--	--
24 x 72	SC694686WF	--	--
36 x 42	SC694762WF	--	--
36 x 60	SC694683WF	SC694878WF	SC694882WF
36 x 72	SC694687WF	SC694879WF	SC694883WF
48 x 42	SC694763WF	--	--
48 x 60	SC694684WF	--	--
48 x 72	SC694688WF	--	--
60 x 42	SC694764WF	--	--
60 x 60	SC694685WF	SC694880WF	SC694884WF
60 x 72	SC694689WF	SC694881WF	SC694885WF

W"x H"	STANDARD Model	DELUXE Model	STANDARD W/ PARTIAL WINDOW Model
24 x 42	SC694655F	SC694652F	SC694753WF
24 x 60	SC694656F	SC694653F	SC694674WF
24 x 72	SC694657F	SC694654F	SC694678WF
36 x 42	SC240224F	SC694845F	SC694754WF
36 x 60	SC238635F	SC694847F	SC694675WF
36 x 72	SC238636F	SC694849F	SC694679WF
48 x 42	SC240225F	SC694851F	SC694755WF
48 x 60	SC238637F	SC694853F	SC694676WF
48 x 72	SC238638F	SC694846F	SC694682WF
60 x 42	SC240226F	SC694848F	SC694756WF
60 x 60	SC238639F	SC694850F	SC694677WF
60 x 72	SC238640F	SC694852F	SC694681WF

PARAMOUNT™ OFFICE PARTITION FURNITURE

Create Private Office Spaces And Cubicles



DESK



CORNER DESK WITH
KEYBOARD AND
MOUSE TRAY



60" 2-DOOR HUTCH



LOCKING 2 DRAWER
LATERAL FILE

LOCKING 3 DRAWER
PEDESTAL FILE

Coordinates with Paramount™ partitions to create a fully furnished work space. Helps optimize work space by adding functionality and storage. 1" thick scratch resistant laminate surfaces on black finished steel frame. Desks include cable management grommet and adjustable leveling glides for uneven surfaces. Desks feature modesty panel. Purchase Optional Bridge, Return, Peninsula, Corner Desk or Corner Connector with Desks to create L & U-shaped workstations. Easy assembly. 1 Year Limited Warranty.

Hanging Shelves & Overhead Cabinets easily attach to partition panels for additional storage space. Return panel required for support. **Overhead Cabinet** provides enclosed storage using a locking flip-top door. Add **Hutch** on top of any work surface for convenient overhead storage. **Lateral and Pedestal Files** can be used freestanding or installed under Desks & Returns. Includes ganged cylinder lock and recessed handles. Add **Caster Kit** to pedestal for mobile application.

Model	Work Surface	W" x D" x H"
SC249012	36" Desk	36 x 24 x 30
SC240279	48" Desk	48 x 24 x 30
SC240265	60" Desk	60 x 24 x 30
SC240266	72" Desk	72 x 24 x 30
SC240267	36" Corner Desk	36 x 36 x 30
SC248993	48" Corner Desk	48 x 48 x 30
SC240269	36" Return Table Right	36 x 24 x 30
SC248917	36" Return Table Left	36 x 24 x 30
SC249013	24" Square Corner Desk	24 x 24 x 30
SC695297	Rounded Corner Desk, Wide	24 x 24 x 30
SC695298	Rounded Corner Desk, Narrow	24 x 24 x 30
SC248994	72" Peninsula	72 x 30 x 30

Specify work surface color suffix: Cherry surface with Charcoal Frame (CH), Gray surface with Charcoal Frame (GY).

126 More Products Available Online – chproducts.com



OPTIONAL KEYBOARD
& MOUSE TRAY



DESK, RETURN
TABLE AND
2 DRAWER
PEDESTAL FILE



PENINSULA

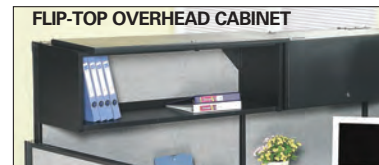

FLIP-TOP OVERHEAD CABINET

Model	Storage (Charcoal)	W" x D" x H"
SC240271	2 Drawer Pedestal File	16 x 20 x 29
SC240272	3 Drawer Pedestal File	16 x 20 x 29
SC248986	2 Drawer Lateral File	30 x 18 x 29
SC240259	36" Hanging Shelf	36 x 14 x 14 1/2
SC240260	48" Hanging Shelf	48 x 14 x 14 1/2
SC240261	60" Hanging Shelf	60 x 14 x 14 1/2
SC240276	36" Overhead Cabinet	36 x 14 x 14 1/2
SC240277	48" Overhead Cabinet	48 x 14 x 14 1/2
SC240278	60" Overhead Cabinet	60 x 14 x 14 1/2
SC240262	36" Hutch - 1 Door	36 x 14 x 36
SC240263	48" Hutch - 1 Door	48 x 14 x 36
SC240264	60" Hutch - 2 Door	60 x 14 x 36
SC190288C	Keyboard Tray	23 x 11
SC190289C	Mouse Tray	8 x 8
SC248991	Caster Kit For Pedestal File/Set of 4	

PARAMOUNT™ OPEN OFFICE DESK

The Paramount™ Open Office Desks incorporate a clean and modular design which can be configured for any office space. The open concept minimizes interruption of the surroundings, and creates a sleek and modern work environment. The work surface is a durable white laminate finish supported by heavy duty steel tube legs in satin black. Each leg has level-adjustable non-marring feet for stability. Available in single or double workstation configurations. Optional translucent or tackable fabric divider partitions. Optional 2-drawer pedestal cabinet with top drawer and tip-proof hanging folder drawer that can hold up to legal-size folders. Easy to clean and assemble.



SC694859
with
SC694861



SC694860



SC694950



SC694858

Model	Description	W" x D" x H"
SC694858	Single Desk	60 x 30 x 30
SC694859	Double-Sided Desk	60 x 60 x 30
SC694860	Translucent Divider for Double-Sided Desk	55 x 1 3/4 x 16
SC694861	Fabric Divider for Double-Sided Desk	55 x 1 3/4 x 16
SC694950	2 Drawer Pedestal Cabinet	15 1/2 x 20 1/2 x 19
SC695450	3 Drawer Pedestal	15 1/2 x 20 1/2 x 23 1/2

STEEL BOOKCASES QUICK ADJUST SHELF



SHELVES SLIDE IN
AND OUT ADJUST
ON 1 1/4" CENTERS

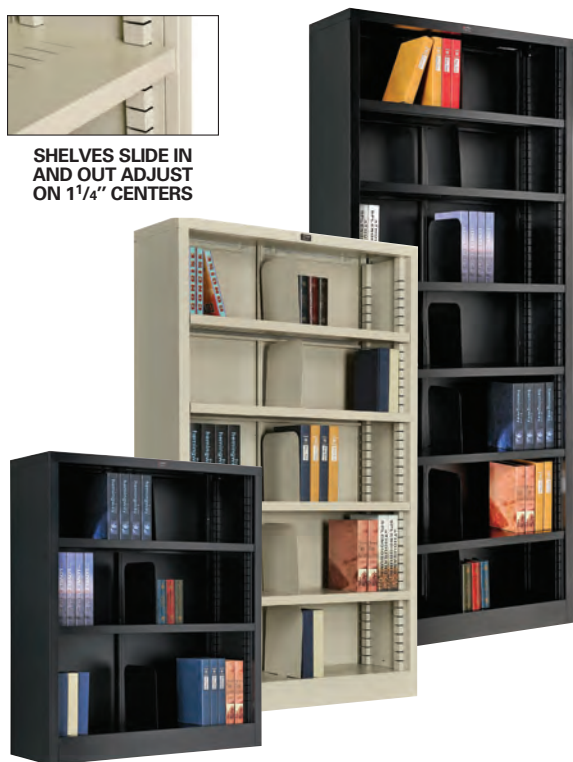

These top-of-the-line quick adjust bookcases complement any office, plant or warehouse decor. Shelves slide in and out easily for easy height adjustments. Includes one divider per shelf opening. Bookshelves are made with heavy gauge double walled steel that is engineered to provide years of use. Durable powder coat finish. Steel book shelves measures 36"W x 12"D. Easy to assemble. Add color suffix to model: Putty (PY) or Black (BK).

Ht."	Openings	Model
42	3	SC277440
60	5	SC277441
84	7	SC277442
	Extra Shelf	SC277443

PRIVACY BOOTH

Helps provide privacy for public computer use including call centers, test sites, learning centers and more. Privacy booths help health care environments meet HIPAA privacy regulations and guidelines. 5/8" thick laminated panels in light oak finish are stain and scratch resistant. Black metal frame with adjustable leveling floor glides. Overall 48"H x 32 3/4"W x 24 1/2"D. Work surface is 29"H. Slide-out keyboard tray is 11 3/4"D. Add-on-Booth helps create extended rows using black metal connectors. Easy assembly.



Description	Model
Privacy Booth	SC250771
Add-on Booth	SC250772

SECURITY AUDIO/VISUAL CART



500 lb.
capacity



REAR
DOOR

Uniquely designed steel cart offers Rear Access Door enabling quick and easy cable management. Front and rear doors lock with the same key for convenience. Rear door has louvers for ventilation and features a punch-out for a Fan Kit (sold separately). Includes a 19 1/2" x 19 1/2" Height Adjustable Slide-Out Shelf with full extension ball bearing slides that adjust quickly on 2" increments for additional access to peripheral connections. Gray laminated work surface and cabinet base have convenient ports for easy wire management. 25"W x 23"D x 34"H overall (inside cabinet dimensions are 20 3/4"W x 21"D x 23 1/4"H). Rolls easily on 5" rubber swivel casters (2 with brakes). Assembles easily. Available in four durable powder-coat finishes. Specify cart and shelves color suffix: Black (BK), Blue (BL), Gray (GY), and Putty (PY).

AVAILABLE IN
4 COLORS!

Model	Description
SC241659	Security Audio/Visual Cart
SC241863	22 1/2"D x 12"W side shelves (set of 2)
SC634141	Fan Kit (120V)
SC607734A	6 Outlet Power Strip
SCB251096	14 ga. 50' Electrical Cord

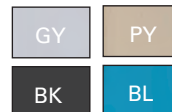

AUDIO/VISUAL & INSTRUMENT TRUCK

OPTIONAL DOCUMENT HOLDER.



SC502282

Ideal for electronic equipment, these all welded steel trucks provide secure transport. Flush top shelf for easy loading. Middle and bottom shelves offer a 1/2" lip to retain product. Feature non-slip rubber padded non-conductive shelf mats. Vibration reducing 2 swivel, 2 rigid 8" full pneumatic wheels. **Security Model** cabinet doors can be padlocked for greatest safety. Shipped assembled. Chip resistant powder coat finish.

1200 lb. capacity

OPTIONAL OUTLET STRIP



SECURITY MODEL

Model	Description	Shelf Clearance"	L' x W x H"
SC502280	2-Shelf Model	17	36 x 24 x 31
SC502282	2-Shelf Model	17	48 x 24 x 31
SC502284	2-Shelf Model	17	48 x 30 x 31
SC502286	2-Shelf Model	17	60 x 30 x 31
SC251406	3-Shelf Model	9 1/4	36 x 24 x 34
SC251407	3-Shelf Model	9 1/4	48 x 24 x 34
SC251408	3-Shelf Model	9 1/4	48 x 30 x 34
SC251409	3-Shelf Model	9 1/4	60 x 30 x 34
SC502047	Security Model	17	36 x 24 x 31
SC502048	Security Model	17	48 x 24 x 31
SC502049	Security Model	17	48 x 30 x 31
SC502050	Security Model	17	60 x 30 x 31

ACCESSORIES

Model	Description
SC959101K	Padlock with 2 keys
SC502298E	6 outlet power strip
SC502289A	Utility Drawer - fits 2 shelf model only
SC241533	Security Cable Kit with padlock
SC489070	Chrome Document Holder

STEEL AUDIO/VISUAL & INSTRUMENT CART



SC113116



SECURITY MODEL
SC113117



BIG WHEEL SHELF MODEL
SC113132

Move and store electronic and other valuable equipment. Shelves adjust on 4" increments and have a 1/2" lip. Top shelf has a vinyl mat to keep equipment from sliding. Convenient push handle and cabling holes. Rolls smoothly on ball bearing rubber wheel casters. Shelf colors are standard in black. **Also available in colors to help organize inventory or supplies. Please specify color: Blue (BL), Yellow (YL), Red (RD) and Green (GN).**

Locking **security model** (available in black only) has a 15"H reinforced door with recessed handle and full piano hinge. 24" x 18", 24"-42"H. Assembles easily. All units include a 3-outlet power strip with 15 ft. 3-wire cord and durable baked black finish. Ready to assemble. **250 lb. capacity.** 5 Year Limited Warranty.

CART with four swivel 4" non-marring casters (2 locking).

Model	Description
SC113116	Shelf Model
SC113117	Security Model

BIG WHEEL CART with two 8" wheels, two 4" locking non-marring swivel casters.

Model	Description
SC113132	Shelf Model
SC113133	Security Model

ADJUSTABLE STEEL WORKSTATION with Sliding Shelf and Mouse Pad



SC334541BK



OPTIONAL ADJUSTABLE CPU HOLDER

SLIDING SHELF AND RETRACTABLE MOUSEPAD



SC334541BL

Compact 24" L x 18" W steel mobile workstation offers retractable 19 1/2" W x 16" D sliding shelf and pull-out mouse pad which extends to 11". **Includes UL listed 3-outlet power strip with 15' 3-wire cord.** Shelves adjust from 24" to 42" H on 4" increments and have 1/2" lip to retain load. Steers easily with handle grips and 4" swivel casters, 2 with locking brake. Durable powder coat finish. 5 Year Limited Warranty. Assembles easily. **Optional Adjustable CPU Holder** (black only) attaches to either side of workstation, is 18" D and adjusts from 6" to 10" W.

Model	Description
SC334541BK	Workstation (Black)
SC334541BL	Workstation (Blue)
SC241534	Adjustable CPU Holder (Black)

MOBILE SECURITY COMPUTER CABINET

With Rear Access Door and Slide-out Shelf

Secure steel cabinet prevents data theft and vandalism by limiting access to computer, monitor and keyboard. Upper compartment has break resistant acrylic window, fully retractable locking door and holds up to 21" LCD or CRT monitors. Slide-out locking keyboard drawer and adjustable height lower compartment shelf extend fully on ball bearing slides. Lower compartment has locking front and rear access doors. Heavy duty 5" swivel casters (2 locking). Top and bottom compartments are louvered to reduce heat build up and include convenient cable management ports. All doors keyed alike. Optional Fan with 5' power cord reduces heat build-up. Order one fan each for upper, lower and side car compartments. Assembles easily. Available in 4 durable powder coat finishes: Blue, Black, Gray or Putty. Patent Pending. †Add color suffix: Blue (BL), Black (BK), Gray (GY) or Putty (PY).



SHOWN WITH OPTIONAL SHELF SC237368BL

CPU SIDE CAR CABINET

Holds CPU safely and securely; frees up lower compartment space for larger printers. Installs to Global's Mobile Security, LCD and Console Computer Cabinets. Hooks on to either side of lower compartment. Doors are louvered for ventilation. Includes cylinder locks and cable management openings. (Cannot install both side car and side shelf to one side of computer cabinet). Optional Fan helps maintain CPU cooling.

Model	Description	Dimensions
SC242299†	CPU Side Car Cabinet	12"W x 22 1/2"D x 21 1/2"H
SC634141A	Fan (120V)	

Model	Description
SC706669†	Mobile Computer Cabinet
SC237368†	22 1/2"D x 12"W Side Shelves (set of 2)
SC309239	Sliding Mouse Tray
SC634141A	Fan Kit (120V)
SC695247	Side Pocket, Black
SC607734D	6 Outlet Surge Protector .15 Amp, 125V



HEIGHT ADJUSTABLE FULL SUSPENSION SHELF



OPTIONAL SLIDING MOUSE TRAY

BLUE SC706669BL

Dimensions:

Upper compartment interior 24 1/4"W x 21 3/4"D x 21"H
 Lower compartment interior 20 3/4"W x 21"D x 23 1/4"H
 Locking slide-out keyboard drawer 19 1/2"W x 17 3/4"D x 4 1/4"H
 Overall unit 24 1/2"W x 22 1/2"D x 60 3/8"H

MOBILE LCD SECURITY COMPUTER CABINET

Designed to hold up to 21" LCD flat screens. All openings lock with the same key for dependable security. The locking monitor compartment includes a break resistant acrylic window framed in heavy-duty steel, convenient sloped writing surface and 2 organizing compartments for 8 1/2" x 11" papers. Locking keyboard drawer and height adjustable printer shelf extend fully on steel ball bearing suspensions. Lower compartment has front and rear doors. All doors keyed alike. Cable management openings throughout. Rear panels are louvered to dissipate heat. Moves on 5" swivel casters (2 locking). Optional Fan with 5' power cord reduces heat build up. Order one fan each for upper, lower and side car compartments. Assembles easily. Powder coat finish. Patent Pending. †Add color suffix: Blue (BL), Black (BK), Gray (GY) or Putty (PY).



SLOPED WRITING SURFACE

SHOWN WITH OPTIONAL SHELF SC239153BL



OPTIONAL FAN

SHOWN WITH OPTIONAL CPU SIDE CAR CABINET AND OPTIONAL SHELF

Dimensions

Upper compartment interior 24"W x 9"D x 19 1/4"H
 Lower compartment interior 20 3/4"W x 21"D x 23 1/4"H
 Locking slide-out keyboard drawer 19 1/2"W x 17 3/4"D x 2 1/4"H
 Overall unit 24 1/2"W x 22 1/2"D x 62 3/4"H
 Pigeon hole compartments- 11"W x 9"D
 Work surface- 24 1/2"W x 13"D



ASSEMBLED VERSIONS AVAILABLE



OPTIONAL SIDE POCKET



OPTIONAL SLIDING MOUSE TRAY

BLUE SC239153BL

Model	Description
SC239115†	Mobile LCD Cabinet
SC239153†	22 1/2"D x 12"W Side Shelves (set of 2)
SC253700†	CPU Side Car
SC309241	Sliding Mouse Tray
SC253702	Fan Kit (120V)
SC695247	Side Pocket, Black
SC607734E	6 Outlet Surge Protector, 15 Amp 125V

LCD CONSOLE COMPUTER CABINET

A Global Exclusive for the Ultimate Viewing Experience!

SLOPED DISPLAY FOR ERGONOMIC VIEWING

SHOWN WITH OPTIONAL SHELF AND CPU SIDE CAR

LOCKABLE KEYBOARD DRAWER

OPTIONAL SLIDING MOUSE TRAY

SHOWN WITH OPTIONAL SHELF KIT SC432208BL

HEIGHT ADJUSTABLE FULL SUSPENSION SHELF

ONLINE VIDEO & PHOTOS

EXTENDED SERVICE PLAN

Gray (GY) Black (BK) Blue (BL) Putty (PY)

SC695247

VESA CAPABLE MONITORS HAVE 4 STANDARD SCREW HOLES ON BACK 75 x 75mm OR 100 x 100mm

6 1/2" LEDGE ACCOMMODATES KEYBOARD

Designed for optimum, ergonomic viewing that helps increase productivity. Convenient sloped display helps reduce neck strain and glare for clear monitor viewing. Holds LCD VESA mount monitors up to 19" and 3 1/2" thick. The locking monitor compartment includes a break resistant acrylic window framed in heavy-duty steel. Includes a 6 1/2" ledge for additional work surface. Locking keyboard drawer and height adjustable shelf extends fully on steel ball bearing suspensions. Lower compartment has front and rear doors. Rear panels are louvered to reduce heat buildup and have cable management openings throughout. All locks are keyed alike for security that limits access to components and prevents theft and vandalism. Moves on 5" swivel casters (2 locking). Powder coat finish. Assembles easily. Available in Blue, Black, Gray and Putty. **Optional Side Car Cabinet, Side Shelves, Fan and Sliding Mouse Tray** sold separately. Patent pending. †Specify Color Suffix: Blue (BL), Black (BK), Gray (GY), or Putty (PY).



Dimensions

Upper compartment 24 1/2"W x 22 1/2"D x 22 1/8"H
 Lower compartment interior 20 3/4"W x 21"D x 23 1/4"H
 Locking slide-out keyboard drawer 19 1/2"W x 17 3/4"D x 2 1/4"H
 Acrylic Window 15"W x 12"H
 Overall unit 24 1/2"W x 22 1/2"D x 55 1/2"H

Description

Model

SC273115†
 SC253701†
 SC432208†
 SC695247
 SC273113
 SC253703
 SC607734H

Mobile LCD Console Cabinet
 Side Car Cabinet
 22 1/2"D x 12"W Side Shelves (set of 2)
 Side Pocket
 Sliding Mouse Tray
 ††Fan Kit (120V)
 6 Outlet Surge Protector w/on/off switch 15 amp
 †† Order one fan each for upper, lower and side car compartments

COUNTER TOP SECURITY COMPUTER CABINET CPU SECURITY CABINET

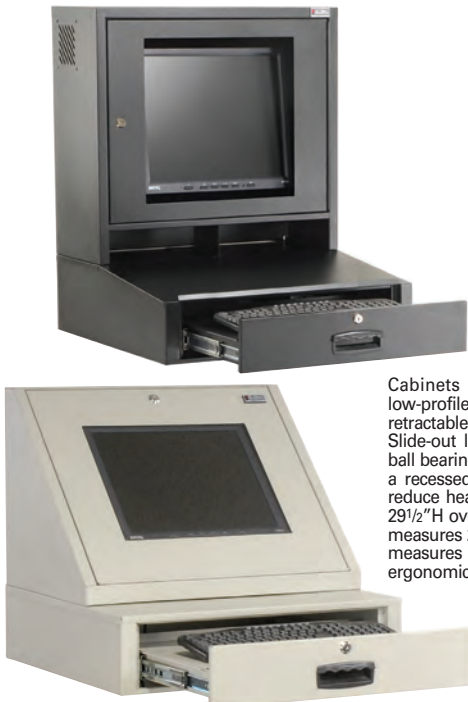

Cabinets provide computer security, with a low-profile build to fit easily on desks or countertops. Fully retractable locking Front door has a break resistant acrylic window. Slide-out locking keyboard/mouse drawer is fully extendable on ball bearing slides. Drawer includes a cylinder lock for security and a recessed drawer handle. Monitor compartment is louvered to reduce heat build up. LCD Cabinet measures 24 1/2"W x 22 1/2"D x 29 1/2"H overall and features a sloped writing surface. CRT Cabinet measures 24 1/2"W x 22 1/2"D x 27 1/8"H overall. Angled LCD Cabinet measures 24 1/2"W x 22 3/8"D x 22 1/4"H overall and features an ergonomic viewing angle.

Model Description

SC239114 LCD Cabinet
 SC607294 CRT Cabinet
 SC273114 LCD Cabinet with Angle
 Specify color suffix: Blue (BL), Black (BK), Gray (GY), or Putty (PY).

This heavy duty side cabinet holds CPU towers safely and securely. Front and rear doors feature louvers for ventilation and cylinder locks for security. Includes 2 keys and 2 exhaust fans to help reduce heat build up. CPU cabinet measures 12"W x 22 1/2"D x 21 1/2"H and can be attached as a side mount or undermount. Available in black or beige colors.

Model	Color
SC249309JBG	Beige
SC249309JBK	Black

INDUSTRIAL COMPUTER CABINET



SC239197JBK

This **heavy duty unit** provides secure storage for all your computer hardware. **Rugged 12 and 16 gauge steel** with channel formed reinforcements for added strength. Upper compartment features a break resistant acrylic window and accommodates LCD up to 24" or CRT monitors up to 21". Lower compartment includes 23"W x 26"D height adjustable slide out shelf at 2" increments. Features include lockable 24 1/4"W x 22"D slide-out keyboard/mouse tray with full extension drawer glides. Cable management grommet. Locking access doors in front and rear with 2 cylinder locks each, all locks keyed alike. Full access door in rear allows for easy wiring and is louvered for ventilation. **Filtered air intake fan** to cool hardware while keeping out dust and debris with **foam seals** on all doors. Non-marking Heavy Duty 5" casters (2 swivel with brake, 2 rigid). **Powder coat finish.** Purchase the **Optional 23U EIA Rail Kit** to mount routers, servers and switches in bottom compartment (hardware included). **Specify color suffix: Blue (BL), Black (BK), or Gray (GY).** Choose between assembled or unassembled.

FULL
EXTENSION
KEYBOARD
TRAY



FOAM SEALS
TO PROTECT
AGAINST
DUST AND
DEBRIS



FILTERED INTAKE FANS COOL
AND KEEP OUT DUST



Dimensions:

Upper Compartment - 25 3/4"W x 28"D x 20 1/2"H
Lower Compartment - 25 3/4"W x 28"D x 33"H
Acrylic Window - 22"W x 13 3/4"H
Overall Unit - 30"W x 30"D x 70 1/2"H

HEIGHT ADJUSTABLE FULL SUSPENSION SHELF

Gray
(GY)

Black
(BK)

Blue
(BL)



OPTIONAL EIA
RAIL KIT

Model	Description
SC239197J	Security Cabinet Unassembled
SC239197A	Security Cabinet Assembled
SC309149	EIA Rail Kit
SC607734G	6 Outlet Surge Protector

LCD INDUSTRIAL COMPUTER CABINET

Features Slim LCD Monitor Compartment and Writing Surface

Perfect for storing flat screen LCD and Plasma monitors up to 24". Industrial LCD cabinets provide optimum security for all your valuable computer equipment. Built to last using rugged 12 and 16 gauge steel with channel reinforcements for extra strength. Rear access and front lower compartment doors include cylinder locks, all locks are keyed alike, 2 locks on rear access door, 1 lock on front lower compartment. Doors feature **foam seals** to keep out dust and debris. Full access door in rear allows easy wiring and is louvered for ventilation. Includes **2 filtered air intake fans**. Flat screen monitors are kept safe in top compartment with a 22"W x 13.75"H break resistant acrylic window. Features a convenient **30"W x 18 1/4"D sloped writing surface** and lockable 24"W x 21 1/4"D full-extension keyboard/mouse tray. Cable management grommet. Lower compartment includes one 23"W x 26"D **height adjustable slide-out shelf** that adjusts at 2" increments. Non-marring 5" heavy duty casters (2 swivel with brakes, 2 rigid). Powder coat finish. Purchase the **Optional 23U EIA Rail Kit SC309149** to mount routers, servers and switches in lower compartment. **Specify Color Suffix: Blue (BL), Black (BK) or Gray (GY).** Choose between assembled or unassembled.

Gray
(GY)

Black
(BK)

Blue
(BL)

Dimensions:

Upper Compartment Interior-
25 3/4"W x 10"D x 22 1/2"H
Lower Compartment -
25 3/4"W x 28 1/8"D x 30 3/4"H
Overall Unit -
30"W x 30"D x 66 3/8"H



Model	Description
SC249190J	LCD Security Cabinet Unassembled
SC249190A	LCD Security Cabinet Assembled
SC607734M	6 Outlet Surge Protector



SC249190JBK

01-800-467-0529

chproducts.com

131

HEAVY DUTY LAN WORKSTATION

Our Heavy-Duty 16 gauge steel-reinforced LAN Stations feature a 30"D, 29"H, 1 1/8" thick plastic laminate work surface to handle even the largest monitors, leaving plenty of workspace. Includes **Two 18"D upper shelves** that are height adjustable on 2" increments. 27"D lower shelf is ideal for housing multiple servers. All shelves are 3/4" thick plastic laminate. 24"W upper shelves support up to 235 lbs. each, 48"-72"W up to 350 lbs. each and up to 500 lbs. each for the 96"W. Each unit offers with triple-leg support (dual leg on 24" unit) with four lateral braces for added stability. Includes **two Vertical Cable Management Channels** that attach to any leg to neatly organize and keep all cables out of the way. Add the caster base with 3" swivel casters for easy office mobility. Optional LCD Tracks are height adjustable on 2" increments to securely mount flat panel monitors to LAN station at the ideal viewing height. Includes 2 monitor mounts that swivel 180 degrees. Gray powder coat finish. Assembles easily.



MODEL SC651319
SHOWN WITH
OPTIONAL ACCESSORIES

OPTIONAL
LCD TRACK

OPTIONAL CASTER BASE
PROVIDES MOBILITY

KEYBOARD TRAY and MOUSE TRAY mount below the work surface. Both adjust up to 5 3/4", tilts ± 15° and swivels 360°. Slides out of the way when not in use.

Model	Description
SC190288	Keyboard Tray
SC190289	Mouse Tray



Online
Video
& Photos

SHOWN WITH
TWO ADDITIONAL SHELVES

Model	Description
SC651317	24"W x 30"D x 74"H LAN Station
SC651318	48"W x 30"D x 74"H LAN Station
SC651319	72"W x 30"D x 74"H LAN Station
SC752170	96"W x 30"D x 74"H LAN Station
ACCESSORIES	
SC651325	24" Caster Base
SC651326	48" Caster Base
SC651327	72" Caster Base
SC253832	96" Caster Base
SC300911	LCD Track for 24" LAN
SC607307	LCD Track for 48" LAN
SC607308	LCD Track for 72" LAN
SC253833	LCD Track for 96" LAN
SC607305A	Additional Monitor Mount
SC752167	24"W Additional Shelf (Set of 2)
SC752168	48"W Additional Shelf
SC752169	72"W Additional Shelf
SC253834	96"W Additional Shelf
SC651321	Wire Keyboard Holder
SC482511	48"-16 Outlet Power Strip, 15 Amp, 15' Cord

SERVER STATION

Perfect for storing all the servers that support your LAN environment. Complete with bottom server shelf and two 18"D shelves which are adjustable in 2" increments. All shelves are 3/4" thick gray plastic laminate. 24"W x 30"D x 74"H. Add additional shelves for more storage and a 24"W caster base for mobility. Gray powder coat finish. Assembles easily.

Model	Description
SC579316	Server Station
SC579317	24"W Shelf (Set of 2)
SC579318	24"W Caster Base

WALL MOUNT LAPTOP SECURITY CABINET



Steel cabinet securely stores a laptop computer to allow convenient stand-up workstation use. Ideal for hospital hallways. Electronic keypad lock uses programmable administrative and user password with emergency key back-up. Interior measures 3"D when closed. Platform measures 16 1/2"W x 12 1/4"D and is cushioned to protect laptops. Platform straps keep laptop securely in place when closed. Includes one 1 1/2" diameter cable management openings. Overall: 19 3/4"W x 4 3/4"D x 15 3/4"H. Gray finish.

Model SC249329

EASY ACCESS DATA CABINET

Protects servers and sensitive telecom equipment from unauthorized access, dust and damage. Rack cabinet supports rack-mountable servers and options. Heavy gauge steel cabinet includes interior mounting channels and hardware. Front and rear locking doors and removable side panels permit full access, and doors are perforated for ventilation. Features include 29" rail to rail usable depth, fully perforated locking front and rear doors, bottom panels that remove to accommodate cabling and a 6 outlet 115 volt, UL listed power strip on mounting panel. This 37U Rack conforms to the industry standard for 19" wide type A rack cabinets. Leveling feet standard (add optional casters for mobility). Black powder coat finish. 24"W x 36"D x 72"H. Choose assembled or unassembled. Also available: optional vented shelves, 2" caster kit, 2200 CFM fan kit, and sliding shelf to customize and expand your storage.



SC239116A WITH
OPTIONAL ACCESSORIES



MOUNTING
RAILS AND
HARDWARE
INCLUDED



VENTED SHELF
SC239117



SLIDE-OUT
SHELF
SC239196



REMOVABLE SIDE
PANELS PERMIT FULL
ACCESS

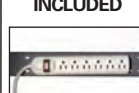

6-OUTLET
STRIP
INCLUDED



2" CASTER KIT
SC239191



TOP MOUNT
FAN KIT
SC239190

Model	Description
SC239116	Data Cabinet Easy Assembly
SC239116A	Data Cabinet Assembled
Model Description	
SC239117	Vented Shelf - 18"W x 28"D
SC239190	Fan Assembly Kit - four 550 CFM
SC239191	Caster Kit - four swivel 2" locking
SC239196	Slide out Shelf 16 1/4"W x 21"D



COMPUTER STATION

Create A Customized Workstation!

Versatile, space saving workstation adapts to your needs. Purchase a complete workstation for sitting or standing users. Choice of **Mobile Base** with 4" casters (2 locking), permanent **Wall Mount**, **Floor Mount** or **Freestanding** base. Or purchase the industrial strength 5" x 5" steel center post and add individual components to build a custom workstation. 78"H mobile units fit through standard doorways. Easy assembly.

Model	Description
Complete Mobile Computer Workstations	
SC239138	78"H Unit w/VESA Mount
SC239141	40"H Laptop Unit
Complete Wall Mount Computer Workstations	
SC239140	72"H Unit w/VESA Mount
SC239194	72"H Laptop Unit
Complete Floor Mount Computer Workstations	
SC239134	81"H Unit w/VESA Mount
SC239193	81"H Kiosk
Add color suffix: Beige (BG) or Black (BK)	
Complete Freestanding Computer Workstations	
SC239134FBK	81"H Freestanding Unit w/VESA Mount
SC239193FBK	81"H Freestanding Kiosk

COMPLETE WORKSTATIONS include CPU holder, plastic laminate work surfaces and VESA mount.



Laptop Tray includes locking crossbar

MOBILE LAPTOP UNITS include locking laptop tray with mobile base and 30"H center post.



MULTI-USER KIOSK DISPLAY
Includes 2 CPU holders, 4 steel work surfaces 81"H steel post with Freestanding base and 2 VESA mounts.

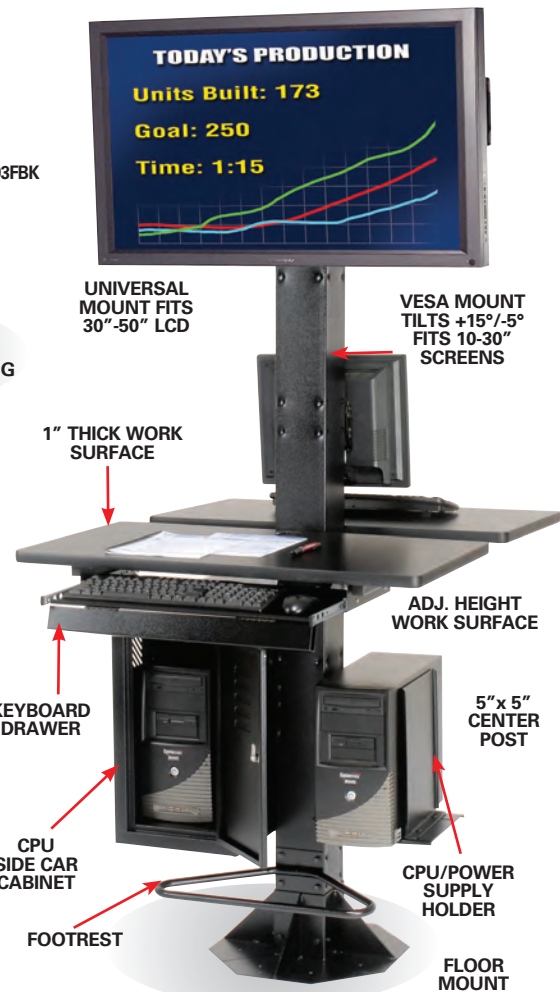

UNIVERSAL MOUNT FITS 30"-50" LCD

VESA MOUNT TILTS +15°/-5° FITS 10-30" SCREENS

1" THICK WORK SURFACE

ADJ. HEIGHT WORK SURFACE

KEYBOARD DRAWER

5" x 5" CENTER POST

CPU SIDE CAR CABINET

CPU/POWER SUPPLY HOLDER

FOOTREST

FLOOR MOUNT

SC239134BK SHOWN WITH OPTIONAL ACCESSORIES

ORBIT COMPONENTS



Keyboard Drawer mounts to steel or laminate work surface.

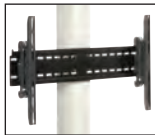

Plasma Mount holds 30-50" screens. Tilts +15/-5°



Flat Panel Arm moves 180° front to back. 270° left to right.



VESA Mount holds 10-30" screens. Tilts +15/-5°



CPU Sidecar Includes two exhaust fans for CPU cooling.



Work Surface Plastic laminate work surface.

Model	Description
SC752152	81"H Post w/fixed base
SC239200	78"H Mobile Post with Caster Base (4" Casters/2 Locking)
SC239146	40"H Mobile Post with Casters
SC239128	72"H Wall Mount Post - 5"W x 2"D
SC752153	Steel Work Surface - 41 1/4"W x 19 1/4"D
Plastic Laminate Work Surface	
SC239130	36"W x 20"D x 1" Thick
SC242257	27"W x 20"D x 1" Thick
SC752154	CPU/Power Supply Holder (up to 9"W)
SC249309	CPU Sidecar Cabinet
SC706644	Flat Panel Monitor Arm (VESA) Color suffix: Beige (BG) or Black (BK)

Model	Description
SC706543	Keyboard Drawer
SC239129	Laptop Tray - 15"W x 14 1/2"D
SC752156	Footrest
Color suffix: Beige (BG) or Black (BK)	
SC752152FBK	81" H Post w/Freestanding Base
SC239195	VESA Mount - Fits 10-30" Screens
SC239150	Universal LCD/Plasma Mount-Fits 30-50" Screens
SC249048	Single Arm with 1 VESA Mount
SC249049	Double Arm with 2 VESA Mount
SC249050	Double Arm with 3 VESA Mount
SC250966	Fliptop Keyboard Mouse Tray
SC607734	6 Outlet Surge Protector (15 Amp, 6' Cord)



WALL MOUNT UNIT INCLUDES:

- Wall mount post
- Plastic laminate work surface
- VESA Mount
- CPU Holder

SC239140BK SHOWN WITH OPTIONAL KEYBOARD DRAWER



PROJECTOR CART

Keep your laptops, LCD and other projection equipment all in one mobile cart. Steel frame with black powder coat finish. Cart measures 30"D x 18"W x 40 1/4"H. Includes laptop shelf that adjusts from 19-39 1/2"H at 1 1/4" increments. Gray laminated wood shelves include cable management openings. Heavy duty 3" swivel casters (2 locking). **Lockable Optional Cabinet** includes 3 removable shelves. Measures 18 1/2"D x 13"W x 21 1/2"H. **Optional Electric strip** has 6 UL listed outlets and 6'L power cord.

**SHOWN WITH
OPTIONAL
CABINET
SC250766GY**

SC250766GY

Model	Description
SC250765GY	Presentation Cart
SC250766GY	Lockable Cabinet
SC607734M	6 Outlet Electric Strip

LCD/PLASMA CART



MOUNT INCLUDED

**MONITOR NOT
INCLUDED**

**SC239192BK
Shown With
Optional
Accessories**



**UNIVERSAL
MOUNT ACCEPTS
30-50" SCREENS**

Safely mount and move flat panel monitor screens with this sturdy steel display cart. The central 5" square x 68"H post is mounted to a mobile caster base. Post features internal cable management. The universal tilt mount holds 30-50" screens and tilts +15 and -5° to provide optimal viewing. Plastic Laminate work surface measures 36"W x 20"D x 1" thick. Base has 4" rubber casters (2 locking). 37 1/2"W x 31 1/4"D x 78"H. Optional accessories include: Keyboard Tray that installs under work surface. CPU Holder that adjusts up to 9"W or **Side Car Cabinet** that securely stores CPU towers and includes **2 exhaust fans and locking vented front and rear doors.**



MOBILE COMPUTER CABINET

Mobile Computer Cabinet provides secure storage for your CPU and supplies. 2 position shelf adjusts to accommodate either a tower or desktop style CPU. Rear cabinet access holes are provided. Slide out keyboard tray has a comfortable wrist rest area to reduce fatigue. Rolls easily on 5" casters. Wire ties and mounting holes provided for tidy cable management. 27"W x 24"D x 49 1/2"H. Easy Assembly.

Model	Color	Assembly
SC694561	Blue	Unassembled
SC694561BK	Black	Unassembled
SC694561BLA	Blue	Assembled
SC694561BKA	Black	Assembled

SC694561

Description	Black	Beige
Plasma/LCD Cart	SC239192BK	SC239192BG
CPU Side Cabinet	SC249309ABK	SC249309BG
CPU/PS Holder	SC752148BK	SC752148
Keyboard Tray	SC706543BK	SC706543BG

LAPTOP, CHROMEBOOK & TABLET CHARGING CARTS



SC985748



SC251761BK



SC987877BK

Model	Device Capacity	Overall W" x D" x H"	Recommended For	Shelves	Compartments W" x D" x H"
SC985748	12	24 x 21 x 40	Yes	Yes	8 23 x 12 x 3 1/2"
SC251761	24	43 1/2 x 21 x 40	Yes	Yes	8 41 x 12 x 3 1/2"
SC987877	36	24 x 21 x 40	Yes	---	3 1 5/8 x 12 x 10 3/8"
SC987878	75	43 1/2 x 21 x 40	Yes	Yes	3 1 5/8 x 12 x 10 3/8"

Our Paramount® Charging carts your best value for keeping your mobile device fleet charged and ready-to-go while providing protection from tampering and theft. Made with all steel construction, each have a wide, non-skid top surface for supplies and equipment. Each side is perforated for ventilation and the doors are channel reinforced and feature 3-point locking for extra security. All Paramount charging carts feature surge-protected outlets. Choose the compartment slot size that will accommodate your mobile device for best compatibility. Roll easily on 4" rubber casters (2 swivel, 2 rigid). Easy assembly. **Add color suffix: Black (BK).**

STANDING COMPUTER WORKSTATION

This computer workstation is perfect for standing applications. Top laminate work surface measures 28³/₄"W x 16"D x 3/4" thick and supports your PC with room for supplies. Keyboard shelf is set at 36"H. Adjustable lower shelf measures 28¹/₄"W x 18"D to hold supplies, a mini-tower CPU or printer. Four 1" swivel casters (2 locking). Sturdy steel black frame measures 28¹/₃"W x 22"D x 46"H overall. Easy assembly. Light Gray finish.



SC277216



MOBILE COMPUTING WORKSTATION



SC242278

SC607300

Move your computer workstation anywhere. Lightweight, durable aluminum post features cable management channel. CPU holder accommodates any size CPU. Glides smoothly on five 2¹/₂" casters (3 locking). **LCD Workstation** includes keyboard/mouse tray and flat panel monitor mount that adjusts to desired height. Keyboard/Mouse tray folds down for convenient storage. 73"H overall. **Laptop Workstation** includes a steel locking laptop tray 15"W x 14¹/₂"D. Locking cross-bar secures laptop and prevents theft. 40"H overall.

Model	Type
SC242278	Laptop
SC607300	LCD

ADJUSTABLE HEIGHT WORK CENTER



OPTIONAL UTILITY SHELF

26 - 28"
HT. ADJ.

SC773170GY

Adjustable 26" to 28"H work surface places user at ideal keying height. Non-glare mar-resistant laminated woodgrain top supports 350 lbs. Full-width modesty panel for extra support. Sturdy 2" x 1" 16 gauge tubular steel frame with scratch-resistant baked enamel finish. Adjustable leveling glides for uneven floors. Easy assembly.

Oak Top Gray Base	Gray Top Gray Base	W" x D"	10"D Extra Shelf
SC773167AK	SC773167GY	30 x 24	---
SC773168AK	SC773168GY	36 x 24	---
SC773169AK	SC773169GY	36 x 30	SC430041GY
SC773170AK	SC773170GY	48 x 30	SC430042GY
SC773171AK	SC773171GY	60 x 30	SC430043GY

STAND-UP WORKSTATION



Model	Description
SC506693	Upright Stand
SC250202	Mouse Shelf

SC506693
and
SC250202

Freestanding unit places your computer, printer, etc., at a perfect height for standing applications. Tubular steel frame is reinforced by two back panels for added stability. **Top Platform** (25¹/₂"W x 22"D) supports monitor at a comfortable viewing height. **Roll-out Keyboard Shelf** (21"W x 16"D) adjusts 40-46"H. Optional **Slide-out Mouse Shelf** stores away under keyboard shelf. **Printer Shelf** (25¹/₂"W x 17"D) supports printer. **Bottom storage shelf** is 23"W x 11³/₄"D. Adjustable computer tower holder (10¹/₄"W x 10¹/₂"D). Two top shelves are adjustable on 2" increments. 25¹/₂"W x 22"D x 44¹/₂"H overall. 4" non-marring rubber casters (2 locking) provide easy transport. Assembles easily.



MOBILE COMPUTER CART

Easily fits through doorways for computer portability. Includes steel post and base with plastic laminate work surface. 27"W x 20"D work surface is 1" thick and easily mounts at various heights. Durable 2" x 5" center post includes built-in cable management openings. Cart moves easily on 24"W x 24 1/2"D caster base. Base features a 10"D shelf and 4" rubber casters (2 locking). 41"H overall. Powder coat finish. Optional accessories include: **Keyboard Tray** that adjusts up to 9"W or **Side Car Cabinet** that securely stores CPU towers and includes 2 exhaust fans and locking vented front and rear doors. Easy assembly. **Specify color suffix: Beige (BG) or Black (BK).**

SC309235BK
SHOWN WITH
OPTIONAL
ACCESSORIES

Description	Model
Computer Cart	SC309235
CPU/PS Holder	SC309236
Keyboard Tray	SC309237
CPU Side Cabinet	SC249309

MOBILE LAPTOP WORKSTATION



Ideal for laptops. Push handle and caster base provide easy workstation mobility. Steel post and base with locking laptop tray. Heavy-duty steel laptop tray includes a locking bar and cylinder lock with 2 keys for security. Tray measures 15"W x 14 1/2" D and mounts to post at 40"H. Durable 2" x 5" center post includes built-in cable management openings. Cart moves easily on 24"W x 24 1/2"D caster base. Base features a 10"D shelf and 4" rubber casters (2 locking). 41"H overall. Powder coat finish. Easy assembly.

Beige	Black
SC239141BG	SC239141BK



MOBILE COMPUTER WORKSTATION

Transport computer and electronic equipment with ease. Choose conventional 34" high or 42" high standing workstation. Open wire design minimizes dust accumulation and maximizes light and air circulation. Three shelves adjust at 1" increments. Sliding keyboard shelf with cushioned wrist rest accepts keyboards up to 21"W x 11"D. 6" height adjustment to ensure a comfortable typing position. Optional four 5" gray polyurethane non-marring, swivel casters (two with dual lock.) 30"W x 24"D. Attractive chrome finish. Easy assembly.

Model	Description
SC579207	34"H. Workstation
SC579208	42"H. Workstation
SC489070	Document Holder
SC579212	5" Caster Set (2 locking)
SC607734	6 Outlet Surge Protector, w/ On/Off switch, 15 AMP, 125v

SC579207
SHOWN WITH OPTIONAL
DOCUMENT HOLDER
AND CASTERS

1200 lb. Capacity

MOBILE AND STATIONARY LAN STATIONS

NEW



800 lb.
Capacity

SC651328



SC250114BK

69"H MOBILE LAN UNIT

Model	W" x D" x H"
SC250113*	36 x 18 x 69
SC250114*	48 x 18 x 69
SC250115*	36 x 24 x 69
SC250116*	48 x 24 x 69
SC250197*	60 x 24 x 69
SC250198*	72 x 24 x 69

*Add (BK) suffix to model

74"H STATIONARY LAN UNIT

SC651328	30 x 30 x 74
SC651329	60 x 30 x 74
SC651330	72 x 30 x 74

MOBILE
UNITS ALSO
AVAILABLE
IN CHROME

Model	Accessories
SC339042	Keyboard Drawer
SC250120	Extra Shelf 18"D x 24"W
SC250121	Extra Shelf 18"D x 36"W
SC250122	Extra Shelf 18"D x 48"W
SC250123	Extra Shelf 24"D x 36"W
SC250124	Extra Shelf 24"D x 48"W
SC489070	Document Holder
SC188580	18" L Shelf Ledge
SC188584	36" L Shelf Ledge
SC188586	48" L Shelf Ledge
SC188588	60" L Shelf Ledge
SC188590	72" L Shelf Ledge
SC651332	Shelf Divider 8"H
SC500592	Caster Set (2 Locking)
SC607734	6 Outlet Surge Protector, 115V

MOBILE PRINTER STANDS



SC250117



NON-MARRING POLYURETHANE
MATERIAL PROTECTS FLOORS

Wire construction promotes air circulation and prevents dust build-up. Printer Shelving comes with three shelves. Shelves adjust on 1" increments. Four 5" polyurethane swivel casters (two with brakes) for complete mobility. 800lb. capacity. Attractive chrome-plated finish. Easy assembly.

Model	W" x D" x H"
SC250117	24 x 18 x 39
SC250118	24 x 18 x 59
SC607734	6 Outlet Surge Protector, 115V

Holds your LAN equipment in one organized workcenter! Wire construction promotes air circulation and prevents dust build-up. **69"H mobile units** come with four wire shelves, one slide-out keyboard shelf with wrist rest (for keyboards up to 23"W x 11"D) and four 5" polyurethane swivel casters (two with brakes) for complete mobility. **74"H stationary units** come with three wire shelves and one laminate shelf. Optional accessories include slide-out keyboard drawer, shelf ledges, shelf dividers, document holders & surge protector. Attractive chrome-plated finish. **For models available in Black, specify (BK).** Easy assembly.

SHOP STOOLS

*Ideal for Warehouse,
Factory or Office*

A-E. STEEL SHOP STOOLS Comfort-designed with the finest quality workmanship and construction. Heavy-duty 18 gauge x 7/8" tubular steel is seam-welded for strength and rigidity. Convenient steel foot ring. **Telescoping legs adjust on 1" increments.** Adjustable height 12"W x 53/4"H backrest. Style C has 14 1/4" square seat. Style A, B and D have 14" round seat. Style B has foam filled gray vinyl upholstered seat/back. Style A, C and D have steel hard board seat. Style A and C have steel backrest. Durable gray baked enamel finish. **350 lb. capacity. Big and Tall Shop Stool** - Heavy duty 18 gauge x 1" tubular steel legs and roomy 18" diameter vinyl upholstered seat. **450 lb. capacity. 1 Year Limited Warranty. Sold 2 per package of a model.**



Ht."	Style	Model	Style	Model
STEEL/HARDBOARD SEAT W/STEEL BACKREST				
18 - 27	A	SC244870	D	SC688305
24 - 33	A	SC244871	D	SC688306
18 - 27	C	SC688309	---	---
24 - 33	C	SC688310	---	---
UPHOLSTERED SEAT AND BACKREST				
18 - 27	B	SC244872	E	SC688307
24 - 33	B	SC244873	E	SC688308
18 - 27	---	---	BIG & TALL SHOP STOOL	
24 - 33	---	---	E	SC506342

F. DIESEL STYLE INDUSTRIAL STOOL Features manual seat height adjustment with nylon covered screw lift. Includes 14" diameter leather padded seat and non-marring nylon floor glides. Overall Size 16 1/2"W x 16 1/2"D. Seat height range 22" to 27"H. Steel frame construction with a clear coat pewter finish. Square foot ring with protective rubber guards. Lifetime Limited Warranty. Easy Assembly.

Style	Model
F	SC250569

G. WOODEN SWIVEL STOOL Contoured seated back with pneumatic seat height adjust from 20" to 25". Adjustable 14"W x 6"H back, 15 1/2"W x 14"D contoured waterfall seat with foot ring relieves pressure and reduces lower back fatigue. Heavy gauge, tubular steel frame. Gray baked enamel finish. Easy assembly. 2 Year Limited Warranty.

Style	Model
G	SC240150

H. UPHOLSTERED SWIVEL STOOL Wipe-clean vinyl upholstered stool is ideal for mailroom, factory or warehouse. 30" seat height. Seat measures 14 1/2" diameter x 3" thick seat with gray powder coated steel base. Easy assembly. 1 Year Limited Warranty.

Style	Model
H	SC238712

I. PARAMOUNT® ALUMINUM STOOL Sleek contemporary design provides efficient long lasting seating. Easy to maintain. Overall dimensions 16 3/4"W x 20" D x 42 1/2"H. Color finish Aluminum.

Style	Model
I	SC695254



SC238712

15 YEAR LIMITED WARRANTY

SC695254

CONTOURED PLASTIC STOOL



Contoured design promotes good posture and features ventilation slot for comfort. Molded polypropylene seat with black tubular frame for strength and durability. Easy to clean 17"W x 16"D seat and 16"sq. back. Pneumatic 21"-31" seat height adjustment. Height adjustable 7³/₄"-17³/₄" 360° foot rest. Five blade caster base. Easy assembly. 1 Year Limited Warranty.

Model	Description
SC506548	Plastic Stool
SC506818	Optional Glides



ERGONOMIC WORK STANDS

Support your body while sitting or standing. Ergonomically designed to allow mobility without adding pressure to back and lower body. Great when working for long periods of time on machinery or assembly line. Waterfall contour seat allows proper leg circulation. Self skinned black polyurethane padded seat for durability and comfort. Tilt control knob allows seat to tilt 15°, or can be locked for stability. 24" 5 Blade style has 14"W x 10" L seat with 21"- 31"H pneumatic seat height adjustment. 1 Year Limited Warranty. **Triangular** style has wide base for stability. 12¹/₂"W x 8¹/₂"D seat with a 22³/₄"- 32³/₄" height adjustment. Nylon Anti-slip glides for stability. Easy assembly. 1 Year Limited Warranty.

Model	Base
SC571005	5 Blade

ALL-PURPOSE SCOOTER STOOLS

Tough enough for warehouse, factory or machine shop use. All models feature pneumatic height adjustment for easy operator positioning and 14" diameter seat. Style E and F include both casters and glides. Easy to assemble. 1 year Limited Warranty.



ANTI-MICROBIAL VINYL STOOL



Upholstered in beige or black anti-microbial vinyl for easy cleaning. Rugged powder coated steel base has smooth rolling dual wheel casters. Pneumatic adjustment for 19-24" seat height range. Seat: 16" diameter. Back: 15"W x 9"H. Back height adjusts 32-37"H. 4" thick seat. Uses a 25" diameter base as required by the medical industry. 1 Year Limited Warranty.

Description	Beige	Black
With Back	SC240160BG	SC240160BK
Without Back	SC240159BG	SC240159BK

Style	Seat	Base	Seat Ht Adj."	Model
A	Vinyl	Plastic	17 ¹ / ₂ - 22 ³ / ₄	SC240152BK
B	Vinyl w/Back	Plastic	17 ¹ / ₂ - 22 ³ / ₄	SC240157BK
C	Vinyl	Steel	20 - 23 ¹ / ₂	SC240151BK
D	Vinyl w/Back	Steel	20 - 23 ¹ / ₂	SC240158BK
E	Polyurethane	Steel	22 - 29	SC240273
F	Polyurethane	Plastic	17 - 25	SC954733

5-WAY ADJUSTABLE ERGONOMIC STOOL

Ideal for those sitting extended periods. Contoured black 18 1/2"W x 18"D x 2" seat and 16 1/2"W x 13"H back help support the body. Puncture resistant, easy clean self skin polyurethane foam is wear resistant and maintenance free. Independent seat and back tilt angle adjustment for personalized positioning. Backrest features 38" to 48 1/2"H and 2"D adjustment. 22"-32 1/2" pneumatic seat height adjust. Rugged 5-blade base with both casters for mobility and glides for stationary use. **Adjustable 8-18 1/2"H chrome foot ring** for extra comfort. Easy assembly. 1 Year Limited Warranty.



ADJUSTABLE FOOT-RING SC250626



Description
Without Arms
With Arms

Model
SC250626
SC250627



SC250627

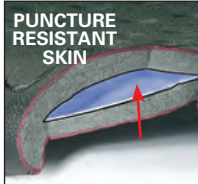

PUNCTURE RESISTANT SKIN
HIGH DENSITY FOAM CORE



INDEPENDENT SEAT AND BACK TILT ANGLE ADJUSTMENT.



ADJUSTABLE MECHANISMS WITH TOUGH FINISHES RESISTS CRACKING AND PEELING.

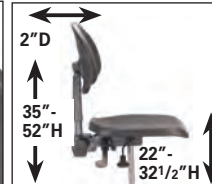

BACK/SEAT HEIGHT AND ANGLE ADJUSTMENTS

PUNCTURE RESISTANT POLYURETHANE INDUSTRIAL STOOLS



FINGERTIP HEIGHT CONTROL

SC571121



SHOWN WITH OPTIONAL LOOP ARMS

ADJUSTABLE FOOT RING

SC571120



SHOWN WITH OPTIONAL T-ARMS

SC571123

BEST VALUE POLYURETHANE SEATING Constructed of wear and puncture-resistant black integral skin urethane foam. **Multi-function** style adjusts both the back and seat angle simultaneously. 18"W x 17"D x 1 1/2" thick seat features a waterfall design that takes pressure off of the knees. Seat height adjusts from 23"-27" for personalized positioning. Adjustable height 17"W x 12"H back helps maintain a proper posture. Style A and B have rugged 5-blade base with both casters for mobility and glides for stationary use. Easy assembly. 1 Year Limited Warranty.

Style	Seat Adjustment	Footrest	Model
A	Standard	360°	SC571121
A	Multifunction	360°	SC252381
B	Standard	180°	SC571120
B	Multifunction	180°	SC506773
C	Spider Base	---	SC571123

OPTIONAL ARMS FOR STYLE A, B, C	Model
T-ARMS. Fixed position, polyurethane over steel.	SC571298
LOOP ARMS. Round edge polyurethane over steel for durability.	SC506556
ADJ T-ARMS. Adjust height as needed. Self skinned polyurethane over steel.	SC744150

8-WAY ANTI-MICROBIAL ERGONOMIC CHAIR & STOOL



SHOWN WITH OPTIONAL T-ARMS



SC250685BK



SC250605BL

Ultra adjustable seating allows personalized positioning for day-long comfort and improved productivity. Extra thick 3 1/2" padding features anti-microbial vinyl upholstery that protects against mold and bacteria growth. Waterfall contoured design helps reduce stress on your knees and improve leg circulation. Contoured back provides lumbar support. Extra large 20"W x 19 1/2"D seat and 19 1/2"W x 20"H back. Polished aluminum base with 2" dual wheel carpet casters provide easy mobility. **Chairs** have 15 1/2"-19 1/2" pneumatic seat height adjustment. **Stools** have 24"-29" pneumatic seat height adjustment. Easy assembly. 1 Year Limited Warranty. **Add color suffix to Chair or Stool Model number: Black (BK), Blue (BL), or Burgundy (BY).**

Model	Description
SC250605	Chair
SC250685	Stool
SC571129A	Optional Adjustable T-Arm Per Pair
SC506818A	Optional Glides (set of 5)

FABRIC UPHOLSTERED STOOL WITH LIGHTWEIGHT PLASTIC BASE



A. VALUE STOOL Contoured 18"W x 18"D seat and 17"W x 14"H back with 2" thick multi-density foam cushion. Pneumatic, 23"-26" height adjustment. Height adjustable chrome plated steel footrest. Five-blade plastic base with 2" dual wheel casters. Easy assembly. Add color suffix: Burgundy (BY), Gray (GY), Blue (BL) or Black (BK). 2 Year Limited Warranty.

B. - C. BODY SENSITIVE[®] STOOL Positions you at the anatomically correct angle to work comfortably and efficiently. Back strain is virtually eliminated. **Fingertip pneumatic height adjustment** and back tilt provide proper lumbar spinal support. Seat height adjusts from 25" to 30". Waterfall 19"W x 18"D x 3 1/2" thick seat improves circulation in the legs. Back is 15" square with adjustable footrest supports for legs and feet. Durable gray 100% nylon upholstery over plushly padded foam cushions. Black five blade molded base with easy roll 2" dual wheel casters. Available in Gray only. Easy Assembly. 2 Year Limited Warranty.

Style	Model
A	SC506592

Style	Description	Adj. Ht. Footrest	Model
B	Without Armrests	360° Steel	SC917159GY
B	With Armrests	360° Steel	SC500904GY
C	Without Armrests	180° Plastic	SC571231GY
C	With Armrests	180° Plastic	SC506786GY



D. - F. FUTURA ERGONOMIC COMFORT STOOL. Ergonomic design provides relief from backaches, tension and muscle strain. 100% nylon upholstery over 2 1/2" padded seat and back cushions gives firm support. Seat is 19"D x 19"W and back is 18" sq. Pneumatic 24" - 29 1/4"H seat height adjustment. Heavy duty adjustable footrest supports legs and feet. Five blade base for maximum stability. Easy-rolling 2" dual disc casters for complete freedom of movement. Easy assembly. Add color suffix: Black (BK), Blue (BL), Burgundy (BY) or Gray (GY). 2 Year Limited Warranty.

Style	Adj. Ht. Footrest	Model
D	360° Plastic	SC516267
E	360° Steel	SC506784
F	180° Plastic	SC506785

Optional Glides for model A-F
SC506818F

OPTIONAL ARMRESTS FOR STYLES A, D, E, F



T-Armrests are textured polyurethane over steel.

Model SC571298



Loop-Armrests places user close to desk. Round edge polyurethane over steel construction for lifetime durability.

Model SC506556



Adjustable Armrests position as needed. Self skinned polyurethane over steel.

Model SC744150

POLYURETHANE STOOL WITH CHROME BASE



SC240275
SHOWN WITH
GLIDES



CHROME
PLATED BASE

4 WAY
ADJUSTABLE

SC240274
SHOWN WITH
CASTERS

Contoured seat and back for comfort and support. Polyurethane seat and back are puncture and wear resistant and easy-to-clean. Seat offers a waterfall edge for improved leg circulation. Ergonomic controls include seat and back angle adjustments and 22" to 32 1/2" pneumatic seat height adjustment. Features **tubular steel chrome plated base** with 360 degree foot ring. Seat measures 18 1/2"W x 18"D x 2" thick. Back measures 16 1/2"W x 13"H. Base includes both casters for mobility and glides for stationary use. **Choose with and without armrests.** Easy Assembly. 1 Year Limited Warranty.

Model	Description
SC240274	Without Arms
SC240275	With Arms

ULTRA COMFORT STOOL



Quality-constructed with contoured 18"W x 16 1/4"D seat and 16"W x 10"H back to help eliminate discomfort and fatigue. Pneumatic seat height adjusts from 21"-25". Extra thick 3 3/4" black fabric upholstered seat. Four-way adjustable backrest for customized support. 18" diameter foot ring allows 360° swivel. Optional 2" hooded ball casters for easy maneuverability, increases stool height 2 1/2". Easy assembly. 1 Year Limited Warranty.

Model
SC240137

OPTIONS



Casters
Model
SC500230



T-Armrests
Model
SC571298



Loop-Armrests
Model
SC506556



Adjustable
T-Armrests
Model
SC744150

VINYL INDUSTRIAL STOOL

Built to last using all welded steel. Ideal for educational, industrial and institutional market applications; including schools, shops, warehouses and design studios. Made using all-welded heavy gauge steel with a charcoal powder coat finish. Black vinyl upholstered seat and back. 22 1/2" to 28 1/2" pneumatic seat height adjustment with tilt lock. Seat measures 14" diameter. Tubular steel base features a fixed height, square foot ring. Includes non-marring floor caps. Back measures 12 1/2"W x 7"H. Easy assembly. 1 Year Limited Warranty.



PNEUMATIC
HEIGHT
ADJUST AND
TILT LOCK



Model
SC249018

POLYURETHANE SHOP STOOLS



SC250788

SC250789



Polyurethane stools are great for extended sitting periods in work shop, lab and industrial environments. Self skinned polyurethane upholstery is puncture and wear resistant, and easy to clean. 14" diameter seat features a steel plate reinforcement that withstands heavy duty use in tough working environments. 26-31" pneumatic seat height adjustment. 1" tubular frame includes a 360 degree foot ring. Foot ring has 2 fixed height positions. **Stool with Back** includes a 13"W x 5 1/2"H back. Back features a 2" back height adjustment knob. Easy assembly. 1 Year Limited Warranty.

Model	Description	Seat Ht."
SC250788	Shop Stool	26-31
SC250789	Shop Stool with Back Rest	26-31

DELUXE POLYURETHANE STOOL 5-Way Adjustable



ADJUSTABLE
T-ARMS



SC250613

SC250612

POLISHED
ALUMINUM BASE

Ribbed seat and back provides comfort and support for extended sitting periods. Self-skinned polyurethane surrounds high density foam core and seat plate reinforcement to offer wear and puncture resistance. Ribbed back is contoured for lumbar support. Back measures 17 1/2"W x 13 1/2"H x 1 1/2" thick. Seat measures 20"W x 18"D x 2" thick. Features extra large 26" diameter polished aluminum steel 5-blade base with both casters for mobility and glides for stationary use. 20" diameter chrome foot ring is height adjustable. 23-28" pneumatic seat height adjustment. Other ergonomic adjustments include seat and back angle and back height adjustment. Optional Armrests measure 4"W x 10"L and are contoured for full arm support. Armrests are adjustable up to 3" vertically and 1 1/2" side-to-side. 2 Year Limited Warranty.

Model	Description
SC250612	Deluxe Stool
SC250613	Deluxe Stool with Armrests

SYNCHRO ERGONOMIC LEATHER STOOLS



9-WAY
ADJUSTABLE

MANAGER

SEAT & BACK
ANGLE
ADJUSTMENT

ATTRACTIVE
ALUMINUM
BASE

360°
FOOTREST,
OPTIONAL
ARMREST

Multi-function
lever synchronizes
total body
movement
by personalizing
back/seat
adjustments



7-WAY
ADJUSTABLE

OPERATOR



7-WAY
ADJUSTABLE

TASK with 180°
FOOTREST,
OPTIONAL
ARMREST



Back and seat angles adjust simultaneously for day long comfort. Pneumatic 24-29"H adjustable seat and 7 1/2"-11"H adjustable footrest ensure proper foot and leg support. Generously sized seat is 3 1/2" thick padding upholstered in genuine black leather with a waterfall edge to reduce knee stress and improve circulation. Contoured 2 1/2"H adjustable back ensures improved posture with lumbar support. 3" vertical and 1" side-to-side adjustable T-arms align arms and wrists for keyboard use. Polypropylene steel reinforced base has 2" carpet casters. Easy assembly.

Task Stool seat 18" sq. and back 17 1/2" sq. Operator Stool seat 18" sq. and back 17 1/2"W x 19"H. Manager Stool has same features as above plus tilt-lock, back-tilt tension adjustments and aluminum base. Seat 20"W x 19 1/2"D and back 19 1/2"W x 20"H. 1 Year Limited Warranty.

Description	360° Chrome Footrest	180° Plastic Footrest
Task	SC506754	SC506775
Task with Arms	SC506755	SC506776
Operator	SC506756	SC506777
Operator with Arms	SC506757	SC506778
Manager	SC506758	SC506788
Manager with Arms	SC506759	SC506789
Optional Glides Model	SC506818H	

SYNCHRO ERGONOMIC FABRIC STOOLS



9 WAY
ADJUSTABLE

MANAGER
WITH
ARMS



ATTRACTIVE
ALUMINUM
BASE

360°
FOOTREST



SEAT & BACK
ANGLE
ADJUSTMENT

OPERATOR
WITH ARMS

7 WAY
ADJUSTABLE

Engineered to make personal positioning easy, so you're more comfortable and productive. Back and seat angle adjust simultaneously to cradle your back for day long comfort. Pneumatic 24"-29" seat height adjustment to ensure that your feet and legs are properly supported with the 7 1/2"-11"H adjustable chrome foot rest. Generous sized seat has extra thick 3 1/2" padding covered in durable 100% acrylic upholstery. Waterfall contoured design helps to reduce stress on knees and ensures proper circulation. Contoured back provides lumbar support and encourages proper posture. Height and side to side adjustable T-arms align arms and wrists correctly for data entry work. Polypropylene steel reinforced base with 2" dual wheel carpet casters. Task Stool seat 18"sq. Back 17 1/2"sq. Operator Stool seat 18"sq. Back 17 1/2"W x 19"H. Manager Stool has same features as above, plus independent adjustable back angle, tilt lock and back tilt tension adjustment. Seat 20"W x 19 1/2"D. Back 19 1/2"W x 20"H. Includes aluminum chair base. Easy assembly. Suffix fabric color to all models: Black (BK), Burgundy (BY) or Gray (GY). Task and Operator also available in Blue (BL). 1 Year Limited Warranty.

Description	360° Chrome Footrest	180° Plastic Footrest
Task	SC808659	SC506780
Task with Arms	SC808660	SC506781
Operator	SC808661	SC506782
Operator with Arms	SC808662	SC506783
Manager	SC808669	SC506812
Manager with Arms	SC808699	SC506813
Optional Glides	SC506818	



7 WAY
ADJUSTABLE

180°
FOOTREST

TASK
WITH ARMS

Multi-function
lever synchronizes
total body
movement
by personalizing
back/seat
adjustments

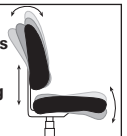

UPHOLSTERED PRODUCTION STOOLS



ADJUSTABLE FOOT RING

SC240144

SC240141





Pneumatic height adjustable seat is 2 1/2" thick and padded for comfort. Seat measures 19 1/2" W x 18 1/2" D. Contoured 16" W x 10" H x 1" thick back adjusts up to 4" vertically and 1 1/2" in or out for personalized support. Powder coated steel five blade base provides stability with an attractive appearance. Includes nylon floor glides. Style A includes a height adjustable 360° foot ring. Style B includes a U-shaped footrest that is fixed to the seat. Purchase optional 2" Hooded Casters for mobility. Optional Armrests provide added support and help reduce arm fatigue. Easy assembly. 1 Year Limited Warranty.

Choice of Vinyl or Fabric



SC240140BK

SC240139BL

OPTIONS			
			
Dual disc series Chair Caster with non-locking nylon wheel Model SC906048	T-Armrests fixed position, textured polyurethane over steel. Model SC571298	Loop-Armrests place user close to desk. Round edge polyurethane over steel construction for lifetime durability. Model SC506556	Adjustable T-Armrests position as needed. Self skinned polyurethane over steel. Model SC744150

Style	Adj. Ht."	Black Vinyl	Gray Fabric	Blue Fabric
A	17 - 21	SC240144	—	—
A	20 - 24	SC240145	SC240142	—
A	25 - 29	SC240146	SC240143	—
B	24 - 28	SC240140BK	SC240139GY	SC240139BL

EXTRA VALUE ERGO STOOLS 6 Way Adjustable



ADJUSTABLE FOOTRING

SC506779BL

SC506811BY

This fully adjustable ergonomic seating is ideal for office, warehouse or training area. Contour built-in lumbar curve is 2 1/4" height adjustable to provide firm body support for increased employee productivity. 25° back recline infinitely adjusts for balanced posture. Pneumatic mechanism instantly changes stool height 23 1/2" to 28 1/2" H to help take pressure off legs. Seat back adjusts 2 1/4" in/out for accurate positioning of body on seat. Back contoured cushion is 19" H x 16 1/2" W. Roomy 17" sq. seat with firm 2" foam cushion and plastic shell back for long life. Comfortable 12" W x 8" H loop arms adjust 1" in/out. Easy assembly. Suffix fabric color to model number: **Black (BK), Blue (BL), Burgundy (BY) or Gray (GY)**. 1 Year Limited Warranty.

Description	Model
Stool with 180° Footrest	SC506779
Stool with 360° Footrest	SC506811
Optional Glides	SC506818

OPTIONAL ADJUSTABLE T-ARMRESTS



C



OPTIONAL ADJUSTABLE T-ARMRESTS



D

OPTIONAL LOOP ARMRESTS



E

C - E. INDUSTRIAL ANTI-MICROBIAL STOOLS Durable contoured foam padded 19 1/2" sq. seat and back provide ultimate comfort for long-term sitting. Black anti-microbial vinyl upholstery. Stool footrest choices include adjustable 180° heavy duty plastic adjustable 360° spider base with 5 footrest positions and chrome-plated ring. 23"-27" pneumatic seat height adjustment. 180° and 360° footrest styles include casters for mobility and glides for stationary use. Easy assembly. 1 Year Limited Warranty.

Style	Model	Footrest
C	SC571122	Spider Base
D	SC571118	180°
E	SC571119	360°

PUNCTURE PROOF ERGONOMIC CHAIR



SC250628



SC250629



PUNCTURE RESISTANT SKIN

REINFORCED SEAT PLATE



HIGH DENSITY FOAM CORE



INDEPENDENT SEAT AND BACK ADJUSTMENTS

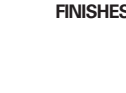

ADJUSTABLE MECHANISMS WITH TOUGH FINISHES



Online Video & Photos

Contoured seat and back provide comfortable support. Puncture and tear resistant black polyurethane foam with tough outer self skin endures tough environments. Independent seat and back tilt angle adjustments allow personalized positioning. Backrest features 32 1/2-37 1/2" H and 2" D adjustments. 16-21" pneumatic seat height adjust. Seat: 18 1/2" W x 18" D x 2" thick. Back: 16 1/2" W x 13" H. Rugged 5-blade base includes casters for mobility and glides for stationary use. Easy assembly. 1 Year Limited Warranty.

Description	Model
Without Arms	SC250628
With Arms	SC250629

CONTOURED PLASTIC CHAIR



PNEUMATIC HEIGHT ADJUSTMENT
14" - 19 1/4"

Contoured design promotes good posture and features ventilation slot for comfort. Molded black polypropylene puncture proof seat with black tubular frame for strength and durability. Easy to clean 17" W x 16" D seat and 16" sq. back. Pneumatic seat height adjustment from 14" to 19 1/4". Five blade caster base. Easy assembly. 1 Year Limited Warranty.

Chair	SC921357
Opt. Glides	SC506818

DELUXE POLYURETHANE CHAIR

DELUXE SEAT SIZE
20" W X 18" D

ADJUSTABLE
ARMREST



SC250610

POLISHED ALUMINUM BASE



SC250611

Easy-to-clean, washable self-skinned polyurethane resists chemicals and lubricants. Ribbed seat and back provides support for extended sitting periods. High density foam core and seat plate reinforcement offer wear and puncture resistance. Seat measures 20" W x 18" D x 2" thick. Back measures 17 3/4" W x 13 1/2" H x 1 1/2" thick. Waterfall edge seat helps improve leg circulation. 26" diameter chrome plated steel 5-blade base. 17-22" pneumatic seat height adjustment. Include back angle and back height adjustment. Optional Armrests measure 4" W x 10" L and are adjustable up to 3" vertically and 1 1/2" side-to-side. Easy assembly. 2 Year Limited Warranty.

Model	Description
SC250610	Deluxe Chair
SC250611	Deluxe Chair With Armrest

INDUSTRIAL POLYURETHANE CHAIR



Built to last and offers comfortable seating for an affordable price! Upholstered in black integral skinned urethane foam that is wear and puncture resistant. 18" W x 17" D x 1 1/2" thick seat with waterfall edge. 18-22" pneumatic seat height control. 17" W x 12" H back is height adjustable to help maintain proper posture. Strong 5 blade base includes both casters for mobile use and glides for stationary use. 1 Year Limited Warranty.



BOTH GLIDES AND CASTERS INCLUDED

Model
SC252251

Options	Model
T-Arms	SC571298
Loop Arms	SC506556
Adj. T-Arms	SC744150

ERGONOMIC BIG & TALL MOBILE STOOL



ADJUSTABLE
HEIGHT ARM RESTS

**400 lb.
capacity!**

Durable and stylish seating designed for the big and tall. Contoured, plush 3 1/2" thick 21 5/8"W x 19 5/8"D seat and 19 5/8"W x 26 3/8"H back cushion with lumbar support. Pneumatic 29 1/8"-34 1/4" seat height adjustment. Footrest adjusts 10"-17" in height to take stress off the knees. Height adjustable armrests help reduce fatigue. Sturdy five blade aluminum base with dual wheel swivel casters for added comfort. Easy assembly. 1 Year Limited Warranty.



ADJUSTABLE
FOOT REST

PNEUMATIC
SEAT HEIGHT
ADJUSTMENT

5 BLADE
CASTER
BASE

Model
SC277490

BIG & TALL SEATING



EXCLUSIVE

**450 lb.
capacity**

Accommodates the big and tall with true comfort. Sturdy, reinforced construction for durability. Ultra 5" thick cushioning covered in black acrylic fabric. Roomy 20"D x 23"W swivel seat, 22 1/2"W x 23"H back. Pneumatic 27"-30 1/2" height adjustment. Four footrest heights for customized leg support. Durable spider base with glides. Optional arms adjust vertically and in and out. Easy assembly. 1 Year Limited Warranty.



Description	Model
Without Arms	SC506553
With Arms	SC506554

PARAMOUNT® MESH BACK STOOLS

NEW

PNEUMATIC
SEAT HEIGHT
ADJUSTMENT
24"-34" HIGH



ADJUSTABLE
FOOT REST

SC695262

Paramount® Mesh Back Stools are perfect for Office, Warehouse, Training Area and more. Ergonomic design with nylon mesh back conforms to body for cool, ventilated and supportive comfort. 16 1/2"H x 17 3/4"W plastic trim backrest ensures long lasting durability and built-in lumbar support provides added back comfort. Contoured back provides lumbar support and encourages proper posture. 24" - 34" seat height adjustment. Height adjustable T-arms. Polypropylene five-blade base with 2" dual-wheel carpet casters provide easy mobility. Choose between **Fabric** or **Vinyl** seat. Easy assembly. 1 Year Limited Warranty.

Seat	Model
Fabric	SC695262
Vinyl	SC695263

VALUE PLUS FABRIC TASK CHAIR



OPTIONAL LOOP
ARMREST



Options	Model
T-Arms	SC571298
Loop Arms	SC506556
Adj. T-Arms	SC744150

Contoured 2 1/4" thick foam padded seat (18"W x 17"D) and pivoting height adjustable back (16 1/4"W x 11"H). Pneumatic lift instantly adjusts seat 16-21"H. 5 blade plastic base with casters. Easy assembly. 2 Year Limited Warranty.

Black	Gray
SC384100BK	SC384100GY

EXTRA COMFORT FABRIC TASK CHAIR

OPTIONAL
ADJUSTABLE
T-ARMREST



Extra Comfort roomy seat (18"W x 18"D) and back (17"W x 14"H). High density 2 3/16" foam padding for support you can feel. Backrest has pivot angle, height and front-to-back adjustments. 16-19"H pneumatic seat height adjustment help to relieve leg and knee pressure. Add color suffix: **Black (BK)**, **Gray (GY)**, **Blue (BL)** or **Burgundy (BY)**. Easy assembly. 2 Year Limited Warranty.

Model
SC506588



Included On All Tools



SC534180A

20 PIECE SET

SAE STANDARD & DEEP SOCKET & RATCHET SET WITH CASE

- Polished chrome vanadium steel
- Push button/quick release thumb reversible teardrop ratchet handle
- Meets or exceeds ASME standards
- 20 Piece Set Contains:
 - 3/8-13/16" 6 point deep sockets
 - 3/8-7/8" 12 point standard sockets
 - 3/8" drive quick release ratchet handle
 - 3" & 6" extension bars



10 PIECE SCREWDRIVER SET

Cushion grip handle ensures comfort during long periods of use. Screwdrivers include phosphate-plated magnetic black tips.

- (1) 3/16" Standard Flathead Screwdriver
- (1) 3/16" Long Flathead Screwdriver
- (1) 1/4" Standard Flathead Screwdriver
- (1) 1/4" Stubby Flathead Screwdriver
- (1) 5/16" Standard Flathead Screwdriver
- (1) 3/8" Standard Flathead Screwdriver
- (1) #1 Standard Phillips Screwdriver
- (1) #2 Standard Phillips Screwdriver
- (1) #2 Stubby Phillips Screwdriver
- (1) #3 Standard Phillips Screwdriver



SC534183A

7 PIECE NUT DRIVER SET

Made from chrome vanadium steel with a cushion grip handle. Nut drivers measure 7-1/4" long and feature size markings for easy identification.

- (1) 3/16" Nut Driver
- (1) 1/4" Nut Driver
- (1) 5/16" Nut Driver
- (1) 11/32" Nut Driver
- (1) 3/8" Nut Driver
- (1) 7/16" Nut Driver
- (1) 1/2" Nut Driver



SC534199A

AVIATION SNIPS

- Chrome molybdenum steel
- Serrated edges
- TPR ergonomic handles with cushion grips
- Meets or exceeds ASME standards

Model	Description
SC534190A	9-3/4" Straight Cut
SC534191A	9-3/4" Left Cut
SC534192A	9-3/4" Right Cut
SC534306A	Set of 3 Snips



PLIERS

- Chrome molybdenum steel
- Thermoplastic rubber ergonomic handles with cushion grips
- Drop forged & hardened cutting edges
- Meets or exceeds ASME standards

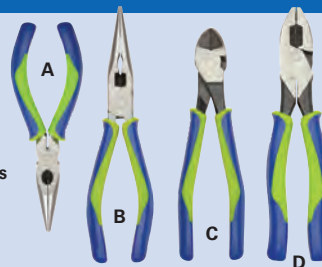

Style	Model	Description
A	SC534196A	6" Long Nose Pliers
B	SC534195A	8" Long Nose Pliers
C	SC534197A	7" Diagonal Pliers
D	SC534198A	9" Linesman Pliers

ADJUSTABLE WRENCHES

- Chrome vanadium steel
- Black phosphate finish
- Drop forged & heat treated
- Knurled adjustment knob
- Precision scale
- Meets or exceeds ASME standards

Model	Description
SC534200A	6" Wrench
SC602190A	8" Wrench
SC602191A	10" Wrench
SC602192A	12" Wrench
SC534307A	Set of 3 (6", 8", 10")



COMBINATION & REVERSIBLE RATCHETING WRENCH SETS

- Drop forged & heat treated chrome vanadium steel
- Mirror polished finish w/15P offset
- Meets or exceeds ASME standards
- Rugged carry pouch



Reversible ratcheting wrenches include thumb reversing switch

Model	Contains
SC534182A	3/8, 7/16, 1/2, 9/16, 5/8, 3/4" (6 Pieces)
SC534181A	1/4, 3/8, 7/16, 1/2, 9/16, 5/8, 11/16, 3/4, 13/16, 7/8, 15/16" (11 Pieces)

12 POINT SAE REVERSIBLE RATCHETING WRENCH SET
SC602193A 5/16, 3/8, 7/16, 1/2, 9/16, 5/8, 11/16, 3/4" (8 pieces)

24" BOLT CUTTER

- Drop forged & heat treated center cut blades
- TPR ergonomic handles with cushion grips
- Converts 50 lbs. hand to 4,000 lbs. cutting pressure
- Meets or exceeds ASME standards



SC534194A

PIPE WRENCHES

Pipe Wrenches are made with floating hook jaws and hardened teeth to ensure a strong grip. Choose from **Cast Iron** or **Aluminum** in a variety of sizes.

Overall Size"	Material	Max Opening"	Brand	Model
10	Cast Iron	2 1/8	Global	SC534185
14	Cast Iron	2 3/16	Global	SC534186
18	Cast Iron	3 7/8	Global	SC534187
24	Cast Iron	3 3/4	Global	SC534188
24	Aluminum	3 3/4	Global	SC534189



WALL MOUNTED FOLDING WRITING DESK

Provides a work surface where you need it. Ideal for doctors offices, hospitals, supply rooms and warehouses. Folding desk mounts to walls at desired work height to accommodate stand-up or sit-down work positions. Durable steel with scratch resistant powder coat finish. Full width handle lowers the desk to a convenient 13" deep work surface. Convenient compartment for pens and small tools. Also includes a storage bin for charts, folders and literature. Magnetic closure keeps door in place. Locking desk includes a cylinder lock with 2 keys for security. 20"W x 33 3/8"D x 16 1/2"H.



SC249997

GLOBAL INDUSTRIAL HOSE REELS



SC534173



Spring driven reels are built for industrial use with heavy gauge reinforced steel construction and corrosion resistant powder coat finish. Latch mechanism and shielded steel spring ensure long life and easy retraction every time. Hose handles air or water and handles up to 300 PSI. Adjustable guide arm allows floor or wall mounting at different angles. Available in 25' or 50' long hoses with an inside diameter of 3/8". Includes the roller guide, 3/8" NPT Inlet hose, hose stopper, 3/8" NPT Male Brass Connector for Air Tool and protective sleeve for hose end.

Hose Length'	Hose ID"	PSI Max	Model
25'	3/8	300	SC534172
50'	3/8	300	SC534173

Perfect for Warehouses and Shipping/Receiving DELUXE SHIPPING DESK

Steel construction is finished with an attractive, scratch resistant gray powder coating. Full suspension 22 3/4"W x 15 3/4"D x 4 1/2"H drawer glides easily on steel ball bearing slides for accurate alignment and includes a cylinder lock for secure storage. Sloped writing surface includes a pigeonhole organizer with two 10 3/4"W and one 11 3/4"W x 12"D x 7 3/4"H pockets to hold full size documents. Closed base keeps out dust and debris for easy maintenance. Measures 34 1/2"W x 30"D x 51 1/2"H. **Drawer Models** feature 13"W x 17 3/4"D locking drawers in 2 heights: 5 1/2"H and 12"H. **Cabinet Model** has 2 independent 15"W x 20"D x 27"H locking compartments that make it ideal for 2 shift operations.



Model	Description
SC237406	Double Cabinet
SC237404	6 Drawer Cabinet
SC237409	7 Drawer Cabinet
SC237405	8 Drawer Cabinet
SC237407	3 Drawer/Cabinet Combo
SC237408	4 Drawer/Cabinet Combo

GLOBAL INDUSTRIAL TOOL CHESTS

Made of heavy 18 gauge steel body with a durable powder coat matte black finish. Top surface features raised edges on 3 sides to retain contents. High security lock with 2 keys secures all drawers. Drawers include aluminum drawer pull handles. Cabinet includes snap-in ball bearing drawer slides for smooth operation under heavy loads. Heavy duty tubular side handles for easy steering. Moves easily on 5" roller bearing casters (2 rigid, 2 swivel with brakes).

Model	Drawers	W" x D" x H"
SC534153	5	27 x 18 x 36 1/2
SC534154	7	27 x 18 x 39 1/2



SC534153



SC534154



MULTIPURPOSE SECURITY WORKBENCH



SC239156



SC239172



SC239169

Secure supplies and tools with these sturdy workbenches with independently locking drawers and cabinets. All welded drawer pedestals have full width aluminum drawer handles and nylon drawer rollers for smooth opening. **Drawers** measure 13"W x 17³/₄"D and are available in 2 different heights: 5¹/₂"H and 12"H. **Cabinets** have locking doors and adjustable shelf. Pedestals measure 15³/₄"W x 20"D x 32"H and can be arranged to suit your needs. Durable gray powder coat finish. Choose from 3 bench tops: **Maple Butcher Block** (1³/₄" thick), **Plastic Laminate** (1⁵/₈" thick) or **Shop Top** (1³/₄" thick). Easy assembly.

W" x D"	Drawers/Cabinets	Maple	Plastic	Shop Top
		Model	Model	Model
60 x 30	3 Door Cabinets	SC239154	SC239164	SC239174
60 x 30	6 Drawers/Cabinet	SC239155	SC239165	SC239175
60 x 30	7 Drawers/Cabinet	SC239156	SC239166	SC239176
60 x 30	8 Drawers/Cabinet	SC239157	SC239167	SC239177
60 x 30	12 Drawers 5 ¹ / ₂ "H	SC239158	SC239168	SC239178
72 x 24	6 Drawers/2 Cabinets	SC253766	SC253771	---
72 x 24	8 Drawers/2 Cabinets	SC253767	SC253772	---
72 x 24	12 Drawers/ 2 Cabinets	SC253768	SC253773	---
72 x 24	14 Drawers	SC253769	SC253774	---
72 x 24	16 Drawers 5 ¹ / ₂ "H	SC253770	SC253775	---
72 x 30	6 Drawers/2 Cabinets	SC239159	SC239169	SC239179
72 x 30	8 Drawers/2 Cabinets	SC239160	SC239170	SC239180
72 x 30	12 Drawers/Cabinet	SC239161	SC239171	SC239181
72 x 30	14 Drawers	SC239162	SC239172	SC239182
72 x 30	16 Drawers 5 ¹ / ₂ "H	SC239163	SC239173	SC239183

HEAVY DUTY CABINET BENCHES



SC184477

TWO SHELF WITH OPTIONAL DOORS



SC185125

Combines enclosed storage and a rugged work surface for craftsmen or assembly work. Endures years of heavy use. 250 lb. capacity shelves adjust on 2³/₈" centers. 4¹/₂"H drawers have a 50 lb. capacity. Baked tan enamel finish. Easy assembly. 34"H. Optional **Sliding Door Kit** secures shelf storage with cylinder lock.

Choice of 4 Tops: **Steel Top** Strong, box-formed 12 gauge construction to resists stains and buckling. 1³/₄" thick. **Maple Butcher Block Top** Kiln dried with mineral oil finish for hard pounding and hammering. 1³/₄" thick. **Plastic Laminate Top** Ideal for electronic assembly and repair. Easy to clean. 1⁵/₈" thick. **Shop Top** High density particle board core with clear lumbar edge bands. Faced top and bottom with 3⁸" thick, 62 lb. density resin board to resist moisture. 1³/₄" thick.

W" x D"	STEEL	MAPLE	PLASTIC	SHOP TOP
TWO SHELF CABINET				
60 x 30	SC184478	SC184477	SC184480	SC184479
72 x 30	SC184482	SC184481	SC184484	SC184483
SIX DRAWER CABINET				
60 x 30	SC185125	SC185127	SC185129	SC185131
72 x 30	SC185126	SC185128	SC185130	SC185132
TWELVE DRAWER CABINET				
60 x 30	SC185133	SC185135	SC185137	SC185139
72 x 30	SC185134	SC185136	SC185138	SC185140

EXTRA HEAVY DUTY SECURITY WORKBENCH

Features a generous working surface with ample storage. Rugged construction of 14 gauge steel bottom and sides, 16 gauge shelf and doors and an 18 gauge back. Measures 33¹/₂"H with top. Includes 2 doors with keyed handle that enclose 1 centered fixed shelf, 3 drawers measuring 15¹/₂"W x 24"D x 5¹/₂"H each with keyed alike cylinder locks. Choose a 1³/₄" thick **Maple Butcher Block Top** or 1³/₄" thick **Shop Top** (45 lb. density particle board core with smooth resin treated wood surface and hardwood edge banding).



LIGHT BLUE

PUTTY

GRAY

W" x D"	GRAY	LIGHT BLUE	PUTTY
	Model	Model	Model
SHOP TOP 1³/₄" THICK			
60 x 30	SC706431GY	SC706431BL	SC706431PY
72 x 30	SC706432GY	SC706432BL	SC706432PY
MAPLE TOP 1³/₄" THICK			
60 x 30	SC706429GY	SC706429BL	SC706429PY
72 x 30	SC706430GY	SC706430BL	SC706430PY

MOBILE HEAVY DUTY SECURITY CABINET BENCHES

Enclosed cabinet is made with heavy gauge steel to provide security for all your storage needs. Easily transport your workbench where you need it using 5" phenolic swivel casters with brakes. Built to last using rugged 2" square x 14 gauge tubular steel legs that are 36"H. Offers **2000 lb. capacity**. Cabinets include **cut resistant padlockable hasp for security** (padlock sold separately). Interior compartment measures 25 1/2"D x 22"H. 15 Year Limited Warranty. Bench tops are available in plastic, maple, ESD, shop top, phenolic resin, or #304 stainless steel. Choose between standard square edge and safety radius edge. Add an **Optional Center Shelf** for added storage. Quick and easy assembly. **Specify color suffix: Blue (BL) or Tan (TN).**



MODEL SC249205
SHOWN WITH OPTIONAL
CENTER SHELF

W" x D"	SQUARE EDGE BENCH TOP					
	Plastic 1 5/8" Model	Maple 1 3/4" Model	ESD 1 1/4" Model	Shop Top 1 1/2" Model	Phenolic Resin 1" Model	Stainless Steel 1 1/2" Model
60 x 30	SC249203	SC249205	SC249207	SC249209	---	SC249213
72 x 30	SC249204	SC249206	SC249208	SC249210	---	SC249214
SAFETY EDGE BENCH TOP						
60 x 30	SC249215	SC249217	SC249219	SC249221	SC249223	
72 x 30	SC249216	SC249218	SC249220	SC249222	SC249224	

* Safety Edge Shop Top is 1 3/4" thick

Model	Description
SC253970A	60" Cabinet Center Shelf
SC253971A	72" Cabinet Center Shelf
SC336375Z	Padlock

EXTRA HEAVY MOBILE SERVICE BENCH

All Welded 2000 lb. Capacity!



Heavy duty construction with **2000 lb. load capacity!** Top work surface features 3-sided lip edges with backstop to retain contents. Cabinet doors include chrome plated locking handles. **Doors are channel reinforced** for added strength and rigidity. All drawers feature **telescoping ball bearing slides** for smooth operation and recessed drawer pulls for a catch-free surface. 5" x 2" non-marring, non-conductive phenolic casters (2 rigid, 2 swivel) offer high strength and impact resistance. **SC253752** includes four 15 1/2"W x 23 1/2"D x 5 1/2"H drawers and an 18"W x 25"H side compartment. **SC253753 & SC253755** include a fixed height shelf to provide 10"H top and 14"H bottom compartments. **SC253754** includes one 15 1/2"W x 23 1/2"D x 5 1/2"H top drawer, 2 fixed height shelves that provide 4", 6" and 7"H openings, and an 18"W x 25"H side compartment. **SC253756** includes four 15 1/2"W x 23 1/2"D x 5 1/2"H drawers and side compartment with fixed height shelf to provide 10"H top and 14"H bottom openings.

Style	Model	W" x D" x H"
A	SC253755	36 x 26 x 34
A	SC253753	48 x 26 x 34
B	SC253754	36 x 26 x 34
C	SC253752	36 x 26 x 34
D	SC253756	48 x 26 x 34
	SC253761	Floor Lock

OSCILLATING CEILING AND I-BEAM FANS

Fans hang down 35" below installation point. Highly efficient 3-speed, PSC type ball bearing, permanently lubricated enclosed motor. Quiet metal precision balanced fan blades. Steel wire guards. Pivot-action fan head allows tilt angle adjustments. Pull chain operation. 12"L, 3-prong 120V power cord. Horsepower rating based upon maximum speed/load. Meets OSHA standards, UL listed. 1 Year Limited Warranty. **Ceiling Mount** includes mounting hardware. **Beam mount** includes two 1 1/2" pipes, clamps with U-brackets and hardware for easy attachment.

Diameter"	HP	CFM	Limited Warranty		Model
			Years	Qty.	
CEILING MOUNT FAN					
24	1/4	7525/6060/4050	1	4+	SC795753
24	1/4	7525/6060/4050	1	1-3	SC795753
24	1/2	8653/6850/4660	3	4+	SC795973
24	1/2	8653/6850/4660	3	1-3	SC795973
30	1/3	8778/7500/6780	1	4+	SC795754
30	1/3	8778/7500/6780	1	1-3	SC795754
30	1/2	10006/8750/7300	3	4+	SC795974
30	1/2	10006/8750/7300	3	1-3	SC795974
I-BEAM MOUNT FAN					
24	1/4	7525/6060/4050	1	4+	SC795751
24	1/4	7525/6060/4050	1	1-3	SC795751
24	1/2	8653/6850/4660	3	4+	SC795971
24	1/2	8653/6850/4660	3	1-3	SC795971
30	1/3	8778/7500/6780	1	4+	SC795752
30	1/3	8778/7500/6780	1	1-3	SC795752
30	1/2	10006/8750/7300	3	4+	SC795972
30	1/2	10006/8750/7300	3	1-3	SC795972

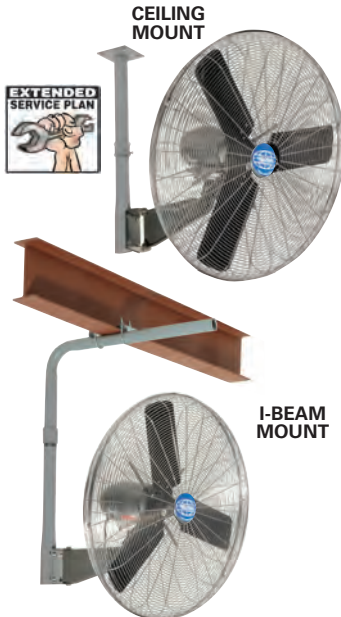

UL WORKSTATION FAN



Easily Mount to walls, ceilings, workbenches and machines. Work fans can be mounted to rotate 360° both horizontally and vertically. Pull chain operation, 120V single phase motor and 10' long SJT conductor cord. Metal fan blades are enclosed in double locking wire guards for safety. Meets OSHA standards, UL listed. 1 Year Limited Warranty.

Blade Dia."	HP	Max. Amps	CFM		Model
			High	Low	
12	1/15	.53	1,855	1,190	SC294492
18	1/3	1.5	4,600	3,200	SC294493
24	1/3	1.9	8,000	5,900	SC294494

INDUSTRIAL GRADE SHOP AND SHIPPING DESKS



WALL MOUNTED
34 1/2"W x 30"D.
SC634177BL

SC254635



ADJUSTABLE HEIGHT LEG

*SC249690



* SHOWN WITH
OPTIONAL HOOK
SET & LIGHT KIT



SC249458

ADJUSTABLE HEIGHT LEG



SC300912



SECURE DRAWER STORAGE



DOUBLE REINFORCED CONSTRUCTION



STEEL BALL BEARINGS DRAWER SLIDES

OPTIONAL DUAL SIDED ELECTRICAL OUTLET



Perfect for warehouses and shipping & receiving areas! Rugged steel channel-reinforced work surface measures 34 1/2"W x 30"D and has a 2" slope from back to front. Features 7 3/4"H x 12"D pigeonhole riser that holds supplies and supports computer monitors. Drawer glides easily on steel ball bearing slides, includes a cylinder lock for security and measures 22 3/4"W x 15 3/4"D x 4 1/2"H. Durable blue powder coat finish. **Height Adjustable Shop Desk** fights fatigue with height adjustments from 38" to 42 1/2"H at 1 1/2" increments. 15"D lower shelf included. Electrical Duplex Knockout Holes provide a convenient way of attaching an electrical extension for easy access to power. Outlet easily screws onto the side of desk. No wiring necessary. **Cabinet Desk** has single locking handle. Includes adjustable center shelf. **Wall Mount Desk** includes support brackets for easy installation at any height. All Shop Desks are available with a **Pegboard Riser Shelf** that includes steel uprights, a 28 1/2"H pegboard panel and 12"D overhead shelf. Steel uprights and roll formed pegboard provides added strength and rigidity. Pegboard accepts peg hooks (sold separately) for hanging tools. Shelf and **Pegboard Riser** accepts **Optional Light Kit** (sold separately). **Cabinet Riser** measures 34 1/2"W x 12"D x 19 1/2"H. Easy Assembly.

Model	Description
SC634177BL	Wall Mounted Shop Desk
SC249510	Wall Mounted Shop Desk w/Pegboard Riser
SC249691	Wall Mounted Shop Desk w/Cabinet Riser
SC254635	Shop Desk
SC249458	Shop Desk w/Pegboard Riser
SC249690	Shop Desk w/Cabinet Riser
SC300912	Cabinet Shop Desk
SC249509	Cabinet Shop Desk w/Pegboard Riser
SC249692	Cabinet Shop Desk w/Cabinet Riser
SC249460	Light Kit(For Pegboard and Cabinet Riser Models)
SC300771	3" Swivel Casters (For SC254635 and SC249458)
SC606968D	30 Piece Hook Set (For Pegboard Riser Models)
SC249854	Dual Sided Electrical Outlet
* Shown with Optional Light & Hook Set	

MOBILE PEDESTAL COMPUTER WORKBENCH



Description Model
Optional Fan Kit (115V) SC249189

Mobile pedestal computer workbench provides ease of transport for your workbench where you need it. Can be used as a repair station as well as a computer work center. Built with two steel pedestal cabinets with locks that limit theft and provide access to valuables, computer peripherals, and keyboards. Interior pedestal compartments measure 20 3/4"W x 21"D x 23 1/4"H. Optional fan with 5" power cord reduces heat buildup. One fan can be placed in each pedestal compartment. Height adjustable roll out shelves extend fully on steel ball bearing suspensions. Roll out shelf is height adjustable in 2 1/4" increments. Available in Maple, ESD, Plastic Laminate, and Shop Top. Comes in Black or Blue with four 5" swivel casters (2 locking).

W" x D" x H"	Top Construction	Color	Model
72 x 24 x 34 7/8	Plastic Square Edge	Black	SC318654BK
72 x 24 x 34 7/8	Plastic Square Edge	Blue	SC318654BL
72 x 30 x 34 7/8	Shop Top Square Edge	Blue	SC318647BL
72 x 30 x 34 7/8	Plastic Safety Edge	Blue	SC318648BL
72 x 30 x 35	Maple Safety Edge	Blue	SC318650BL
72 x 30 x 35	Maple Safety Edge	Black	SC318650BK
72 x 30 x 35	Shop Top Safety Edge	Black	SC318649BK
72 x 30 x 35	Shop top Safety Edge	Blue	SC318649BL
72 x 30 x 34 1/2	ESD Safety Edge	Blue	SC318653BL
72 x 30 x 34 1/2	ESD Safety Edge	Black	SC318653BK
72 x 30 x 34 1/2	ESD Square Edge	Blue	SC318652BL
72 x 30 x 34 1/2	ESD Square Edge	Black	SC318652BK

MOBILE OR STATIONARY WORKBENCH

Quality built for years of service. Rugged 18 gauge 1 1/2" tubular steel frame, and double stringer for added rigidity. Stationary model has a fixed height of 31" on leveling glides. Mobile model has a fixed height of 34" on easy-rolling 5" non-marking, locking swivel casters. 1000 lb. capacity. Make either unit more ergonomic by adding easy attaching optional 6" height adjusters. Available with either durable Shop Top or gray plastic laminate work surface. Matching lower shelf included. Gray or blue enamel finish frame. Assembles easily. **Specify color suffix, Gray (GY) or Blue (BL).**

W" x D"	STATIONARY Model	MOBILE Model
1 5/8" SHOP TOP		
60 x 30	SC244864	SC252347
72 x 30	SC244865	SC252348
72 x 36	SC244866	SC252349
1 3/4" PLASTIC TOP		
60 x 30	SC244867	SC244861
72 x 30	SC244868	SC244862
72 x 36	SC244869	SC244863



PLASTIC TOP BENCH

Fixed or Adjustable Height Option

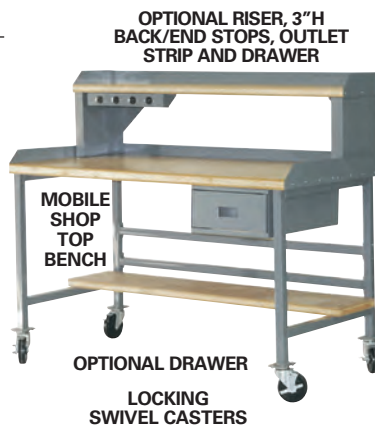

MOBILE SHOP TOP BENCH

OPTIONAL DRAWER

LOCKING SWIVEL CASTERS

ADJUSTABLE HEIGHT MACHINE STAND



Multi-purpose tension frame prevents sway. Made using rugged 16 gauge steel shelves and 12 gauge steel legs for stability and convenience. Offers **2,000 lb. capacity**. Shelves are double bolted for extra strength. Bottom shelf and legs are height adjustable at 3" increments. Baked enamel finish. Easy assembly.

Model	Top Size W" x D"	Adjustable Height"
SC254840	24 x 18	18 and 24
SC254842	24 x 18	30 and 36
SC254844	36 x 24	18 and 24
SC254846	36 x 24	30 and 36

ACCESSORIES

	Model
Riser - for Shop Top 60"W x 12"D x 12"H	SC252350
Riser - for Shop Top 72"W x 12"D x 12"H	SC252351
Riser - for plastic 60"W x 12"D x 12"H	SC651337
Riser - for plastic 72"W x 12"D x 12"H	SC651338
Bench Drawer 15"W x 20"D x 6"H	SC252352
4-outlet Electric Strip - 16"L	SC252353

ACCESSORIES

	Model
Back & End Stops for 60 x 30 Bench	SC252354
Back & End Stops for 72 x 30 Bench	SC252355
Back & End Stops for 72 x 36 Bench	SC252356
Back & End Stops for 60 x 12 Riser	SC252357
Back & End Stops for 72 x 12 Riser	SC252358
Height Adjusters - 6" (set of four)	SC606753

SUPER STRONG WORKBENCH 600 lb. capacity

Chrome plated shelf and posts resist rust, scratches and dents. Includes one reinforced chrome plated wire shelf that provides maximum strength, visibility and ventilation. **Maple Butcher Block** is kiln dried, electronically glued, then cured and sanded smooth. Finished with a penetrating mineral oil protectant. Ideal for multi-purpose use. **Plastic** top is easy-to-clean. Made of high pressure plastic laminate with wood-core. Provides a smooth, tough working surface for all applications. **Shop top** protects against static build up and won't warp or split. Faced on two sides with 3/8" high grade, high density particleboard sealed with a catalyzed finish to resist liquids. **Mobile Benches** include 5" polyurethane casters (2 locking). 39"H. **Stationary Bench** includes adjustable leveling feet and measure 34"H. Easy assembly.

MOBILE STATIONARY

W" x D"	Model	Model
1 5/8" PLASTIC		
60 x 30	SC249314	SC252322
72 x 30	SC249311	SC252325
1 1/2" SHOP TOP		
60 x 30	SC249312	SC252323
72 x 30	SC249313	SC252326
1 3/4" MAPLE		
60 x 30	SC249310	SC252321
72 x 30	SC249315	SC252324



SHOWN WITH ADDITIONAL WIRE SHELF



SHOWN WITH OPTIONAL WIRE BIN

Model	Description
SC607296	Wire Bin w/Dividers 48"W x 20"D x 9"H
SC188558B	Additional Wire Shelf 48"W x 24"D
SC292204A	Swivel Bench Vise 5" jaw opening, 4"W

HEAVY DUTY EXTRA LONG FOLDING ASSEMBLY BENCH

40 Sq. Ft. Working Surface

Accommodates large packing, assembly or heavy-duty operations for increased productivity. Space efficient design folds for storage and sets up in seconds as needed. Heavy-duty **Steel Top** is one piece of 13 gauge steel that's channel formed on 4 sides for superior strength. Strong **Hardboard and Steel Top** is 1/4" thick hardboard bonded to 13 gauge steel for a resilient surface that cushions shocks and heavy pounding. Welded tubular steel legs telescope to adjust height, support storage shelf and are finished in durable gray enamel. Steel angle bracing adds stability and rigidity. Assembles easily.

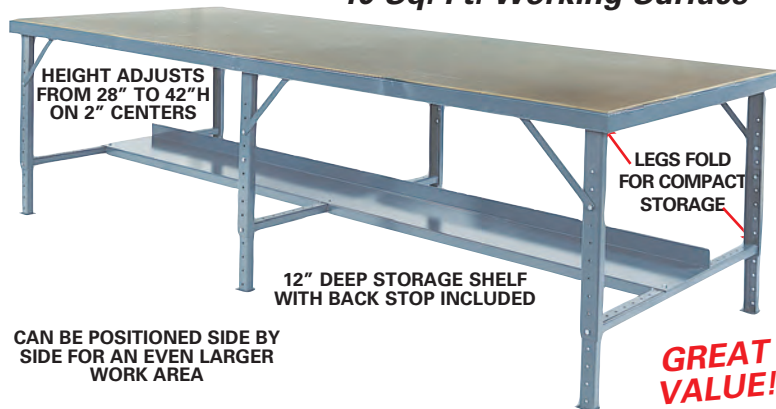

HEIGHT ADJUSTS FROM 28" TO 42"H ON 2" CENTERS

LEGS FOLD FOR COMPACT STORAGE

12" DEEP STORAGE SHELF WITH BACK STOP INCLUDED

CAN BE POSITIONED SIDE BY SIDE FOR AN EVEN LARGER WORK AREA

GREAT VALUE!

W" x D"	STEEL TOP Model	HARDBOARD/STEEL TOP Model
84 x 28	SC606757	SC606766
84 x 34	SC606758	SC606767
84 x 48	SC606759	SC606768
96 x 28	SC606760	SC606769
96 x 34	SC606761	SC606770
96 x 48	SC606762	SC606771
120 x 28	SC606763	---
120 x 34	SC606764	SC606773
120 x 48	SC606765	SC606774

EUROPEAN STYLE WORKSTATION

Full perimeter apron and heavy duty steel frame support work surface to prevent warping. Rugged 2" x 1" x 14 gauge steel legs have adjustable leg levelers for stability. 34"H. Durable scratch resistant gray powder coat finish. Choose between 4 bench top options; **Maple, Plastic, Shop Top and ESD**. For additional work space add the Optional Matching Return (mounts on either side) or the **Optional Attachment Brackets** to connect multiple workstations together. Optional 48"H x 16 gauge steel **Bench Uprights** include 12"W x 3/4" thick plastic laminate cantilever shelf; height adjustable at 2" increments. Other accessories include an Additional Shelf, Light Kit, Bin Panel Kit and Lower Shelf.

Note: Bin panels, light kit and additional shelf require uprights.

BENCH		
W" x D"	Model	Model
MAPLE - 1 3/4" THICK PLASTIC - 1 5/8" THICK		
48 x 24	SC651395	SC651400
60 x 30	SC651396	SC651401
60 x 36	SC651397	SC651402
72 x 30	SC651398	SC651403
72 x 36	SC651399	SC651404
SHOP TOP - 1 1/2" THICK ESD - 1 1/4" THICK		
48 x 24	SC651405	SC651410
60 x 30	SC651406	SC651411
60 x 36	SC651407	SC651412
72 x 30	SC651408	SC651413
72 x 36	SC651409	SC651414

BENCH RETURN		
W" x D"	Model	Model
MAPLE		
36 x 24	SC651415	SC651418
48 x 24	SC651416	SC651419
48 x 30	SC651417	SC651420
SHOP TOP		
ESD		
36 x 24	SC651421	SC651424
48 x 24	SC651422	SC651425
48 x 30	SC651423	SC651426

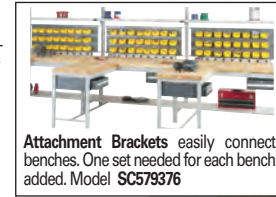

SC651398
BASIC
BENCH WITH
OPTIONAL
ACCESSORIES

BENCH
DRAWER

ELECTRIC
STRIP

FULL PERIMETER
APRON FOR
MAXIMUM
SUPPORT

STORAGE
CABINET

LOWER
SHELF

ACCESSORIES

BENCH UPRIGHTS 48"H with 12"D adjustable cantilever shelf.	
Model	Fits Bench
SC651430	48"W
SC651431	60"W
SC651432	72"W

ADDITIONAL CANTILEVER SHELF with brackets.	
Model	W" x D"
SC651427	48" x 12"
SC651428	60" x 12"
SC651429	72" x 12"

PLASTIC LAMINATE LOWER SHELF

Model	W" x D"
SC651454	48" x 12"
SC651455	60" x 16"
SC651456	72" x 16"

BIN PANEL KIT with 24 (4 1/8" x 5 1/2" x 3"H) yellow plastic bins. Steel Panels are for hanging papers with magnetic clips (not provided).

Model	Bench"	Description
SC651441	48"	2 Bin Panels
SC651442	48"	1 Bin, 1 Steel Panel
SC651443	60"	3 Bin Panels
SC651444	60"	2 Bin, 1 Steel Panel
SC651451	72"	4 Bin Panels
SC651452	72"	3 Bin, 1 Steel Panel

LIGHT KIT - 120 volt. UL Listed. Fits Bench

Model	Fits Bench
SC651433	48"W
SC651434	60"W
SC651435	72"W

STACKABLE BENCH DRAWERS (20"D x 17 1/4"W) with mounting hardware.

Model	Bench Depth"
6 1/2"H DRAWERS	
SC607273	24
SC607274	30
SC607275	36
11 3/4"H DRAWERS	
SC607276	24
SC607277	30
SC607278	36

16"H STORAGE CABINET w/ removable center shelf

Model	Bench Depth"
SC242241	24
SC242242	30
SC242243	36

ADD-ON DRAWERS AND CABINET

Model	Description
SC242268GY	6 1/2"H Drawer
SC242269GY	11 3/4"H Drawer
SC242270GY	16"H Cabinet

ELECTRIC STRIP 48" Long, 8 outlets 115 volt. 6ft cord & plug. UL Listed. Model SC651439

INDUSTRIAL WORKBENCH

All welded extra strong 3"W 13 gauge channel formed legs for heavy duty applications. 60" x 30" x 1 1/2" thick laminate top with side to side steel reinforcement is roomy and strong enough to accommodate any job at hand. Worksurface adjusts from 29 1/2" to 34 1/2" high on 1" increments to create a more ergonomic work station. Extra wide 15" deep shelf included for convenient storage. Optional lockable 10 3/4"W x 18"D x 4 1/4"H steel drawer to store belongings securely. 28" high steel pegboard riser for additional easy to reach storage of tools and accessories. Blue baked enamel finish. Assembles easily.

Model	Description
SC606795	Workbench with Lower Shelf
SC606797BL	Steel Drawer With Cylinder Lock
SC606796	Steel Pegboard Riser
SC606968	30 pc. assorted Pegboard Hook Set
SC607734A	6-Outlet Surge Protector, 120 Volt 6 Ft. Cord
SC606929	Complete Bench (includes riser, lower shelf, surge projector, drawer & 30 pc. peg hook kit)

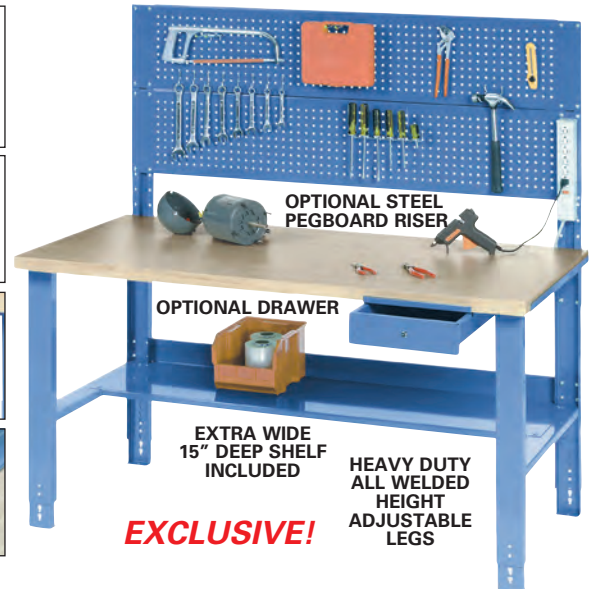
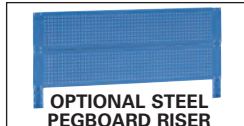

WORKMASTER BENCH

SUPER 2 1/4" THICK TOP

The answer for those looking for the ultimate in durability and value. This multi-purpose bench has a 2 1/4" thick warp resistant top. Stringer braced heavy-duty steel legs guarantee rigidity and stability. Pedestals are 15 3/4"W x 20"D. Drawers have full length aluminum drawer pulls and smooth gliding nylon rollers. Benches are 34 1/4"H. Square Edge Maple Top is kiln dried and sealed with mineral oil protectant. Safety Edge Shop Top is made with a high density particleboard surface and hard lumber core for long lasting durability.



Model SC488010



2 1/4" SQUARE EDGE MAPLE TOP



2 1/4" SAFETY EDGE SHOP TOP

BENCH ACCESSORIES

STACKING DRAWERS can be combined easily. Slide smoothly on nylon rollers. Full length aluminum handle. Includes individual cylinder locks. Equipped with safety stop to prevent drawers from spilling. 17 1/4"W x 20"D.

Model	H"
SC606957GY	6 1/2
SC606958GY	11 3/4

STANDARD DRAWER has channel suspension and mounting pan to prevent dust from filtering through. Recessed handle and padlock hasp. 18 1/4"W x 23 7/8"D x 5 3/8"H.

Model SC606964

OUTLET STRIP attaches to bench top or wall. 115 volts.

Model	L"	Outlets
SC249517B	48	8
SC249516B	72	12

W" x D"	MAPLE TOP		SHOP TOP
	Model		Model
A. 2 LEG BENCH			
60 x 30	SC488007	SC488016	SC488016
72 x 30	SC488008	SC488017	SC488017
72 x 36	SC488009	SC488018	SC488018
B. 3 LEG BENCH			
120 x 30	SC488010	SC488019	SC488019
144 x 30	SC488011	SC488020	SC488020
144 x 36	SC488012	SC488021	SC488021
C. 4 LEG BENCH			
180 x 30	SC488013	SC488022	SC488022
216 x 30	SC488014	SC488023	SC488023
216 x 36	SC488015	SC488024	SC488024
D. 2 CABINET PEDESTALS WITH LEG			
120 x 30	SC607953	SC607959	SC607959
144 x 30	SC607954	SC607960	SC607960
144 x 36	SC607955	SC607961	SC607961
E. CABINET/4 DRAWER PEDESTAL WITH LEG			
120 x 30	SC607962	SC607962	SC607962
144 x 30	SC607957	SC607963	SC607963
144 x 36	SC607958	SC607964	SC607964

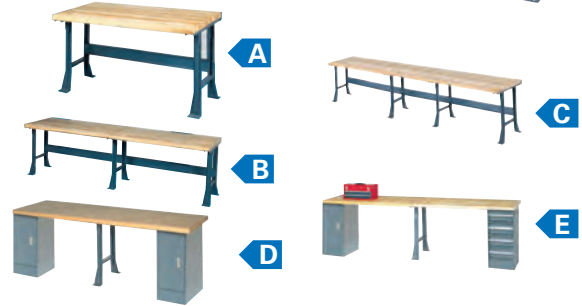

EXTRA-LONG BENCH

Ideal for Production and Assembly

A

**Choice of 4
Tops with 6
Different Base
Combinations!**



Model SC607966



B



C



D



E



F

These extra long workbenches are built with durability in mind. Bench pedestals are 15 3/4"W x 20"D x 32"H featuring full length aluminum drawer pulls and smooth gliding nylon rollers. Inside drawer dimension are 13"W x 17 3/4"D x 5 1/2"H (12"H on the lower drawer for the three drawer pedestal). Leg benches include stringer for added stability. Choose from 4 tops: **Maple Butcher Block** - kiln dried 1 3/4" thick hardwood, mineral oil sealed. **Plastic** - high pressure laminate w/ particle board core 1 5/8" thick. **Shop Top** - 1 1/2" thick, 3/16" high grade hardboard on two sides w/ 45 lb. density particleboard core. **Steel** - 12 gauge heavy-duty 1 7/8" thick top. Double electrical knockouts on legs. Note: 8' steel benches have two 4' tops; all 10' benches have two 5' tops, 12' benches have two 6' tops and all 15' benches have four legs and three 5' tops.

Size W" x D"	MAPLE TOP Model	PLASTIC TOP Model	SHOP TOP Model	STEEL TOP Model
A. CABINET/4-DRAWER PEDESTAL WITH LEG				
96 x 30	SC607965	SC607977	SC607989	SC608013
120 x 30	SC607966	SC607978	SC607990	SC608014
144 x 30	SC607967	SC607979	SC607991	SC608015
B. 2 CABINET PEDESTALS WITH LEG				
96 x 30	SC607968	SC607980	SC607992	SC608016
120 x 30	SC607969	SC607981	SC607993	SC608017
144 x 30	SC607970	SC607982	SC607994	SC608018
C. CABINET/3-DRAWER PEDESTAL WITH LEG				
96 x 30	SC607971	SC607983	SC607995	SC300726
120 x 30	SC607972	SC607984	SC607996	SC300727
144 x 30	SC607973	SC607985	SC607997	SC300728
D. TRIPLE LEG STYLE				
96 x 30	SC300732	SC500362	SC500354	SC500359
120 x 30	SC500367	SC500358	SC500350	SC500373
144 x 30	SC500317	SC500313	SC500309	SC500301
96 x 36	SC500372	SC500364	SC500356	SC500371
120 x 36	SC500369	SC500360	SC500352	SC500375
144 x 36	SC500319	SC500315	SC500311	SC500303
E. 4 LEG STYLE				
180 x 30	SC500318	SC500314	SC500310	SC500302
180 x 36	SC500320	SC500316	SC500312	SC500304
F. 2 CABINET/4-DRAWER PEDESTAL				
96 x 30	SC607974	SC607986	SC607998	----
120 x 30	SC607975	SC607987	SC607999	----
144 x 30	SC607976	SC607988	SC608000	----

MODULAR WORKBENCHES

Modular workbenches are the ideal choice for craftsmen. Quality heavy gauge steel construction throughout. Four different top choices and seven different configurations make it easy to find the right bench for the job. All welded, locking steel pedestals have nylon roller drawers that roll smoothly even when full. All benches are 34" H. Optional Power Riser or Apron Power Center available to provide electricity to the workbench. All pedestals are 15"W x 24"D x 32"H. Finished in durable gray baked enamel.



APRON POWER CENTER
42" wide steel panel. Includes circuit breaker with 8 grounded outlets, pilot light, 8 ft. grounded cord and plug. Fits 72" benches, except style F. 15 amps, 115V.
Model SC752338

FOUR DRAWER PEDESTAL-Four box drawers 13 1/2"W x 22 5/8"D x 6 3/4"H each. Recessed handles, with central lock.

THREE DRAWER PEDESTAL-Two box drawers 13 1/2"W x 22 5/8"D x 6 3/4"H and one 13 1/2"W x 23 1/2"D x 11 1/2"H. Recessed handles and central lock.

CABINET PEDESTAL-13 1/2"W x 23 1/2"D. Three point locking handle. Includes one adjustable shelf. Perfect for storing large items.

POWER RISER. 18"H x 15"D. Includes eight grounded outlets wiring kit, circuit breaker, pilot light, 8 ft. grounded cord and plug. 15 amps, 115V.

Model	W"
SC752339	60
SC752340	72

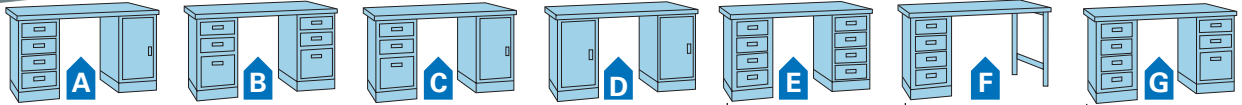

W" x D"	Model	Model	Model	Model	Model	Model	Model
MAPLE BUTCHER BLOCK TOP BENCH - 1 3/4" THICK - Kiln dried, electronically cured, sanded smooth							
60 x 30	SC752282	SC752290	SC752298	SC752306	SC752314	SC752322	SC752330
72 x 30	SC752283	SC752291	SC752299	SC752307	SC752315	SC752323	SC752331
PLASTIC TOP BENCH - 1 5/8" THICK - Super-strong, high pressure laminate, easy clean surface							
60 x 30	SC752284	SC752292	SC752300	SC752308	SC752316	SC752324	SC752332
72 x 30	SC752285	SC752293	SC752301	SC752309	SC752317	SC752325	SC752333
SHOP TOP BENCH - 1 1/2" THICK - High density, non-conductive, non-warping, smooth finish							
60 x 30	SC752286	SC752294	SC752302	SC752310	SC752318	SC752326	SC752334
72 x 30	SC752287	SC752295	SC752303	SC752311	SC752319	SC752327	SC752335
STEEL TOP BENCH - 1 3/4" THICK - Heavy-duty 12 gauge steel							
60 x 30	SC752288	SC752296	SC752304	SC752312	SC752320	SC752328	SC752336
72 x 30	SC752289	SC752297	SC752305	SC752313	SC752321	SC752329	SC752337

POWER LEG WORKBENCH WITH POWER APRON



Self-contained electronic workstation offers unequaled versatility and economy for precision fabricating and assembly work. Designed for labs, cleaning stations, electronic assemblers, technicians, etc. Bench riser with power center adds storage space, keeps work surface clear and uncluttered... puts electrical power at your fingertips. Sliding drawer is handy for tools, supplies and other small items. Panel legs provide rigid stability. Bench height, 34". Easy assembly.

BENCH RISER/POWER CENTER. 18"H x 15"D, includes 8 grounded outlets and wiring kit with circuit breaker, switch-pilot light, 8' grounded cord and plug. 115 volts.

Model	Size
SC254753C	60"
SC254754C	72"
SC254755C	96"

MODEL SC778460 BENCH WITH OPTIONAL RISER/POWER CENTER, BENCH POWER CENTER AND DRAWER

Choose the top that best fits the job...**Plastic Laminate** top resists weak acids, alkalis, moisture, oils and solvents. Tough, non-conductive **Shop Top** top is ruggedly constructed of tempered hardboard bonded to a solid wood core...won't warp or splinter. **Maple Butcher Block** top is ideal for applications where heavy loading and extreme surface abuse occur. ESD white plastic top prevents damage to sensitive electronic circuitry...complies with MIL-B81705B and 101B, 101C, Method 4046. **Select standard square edge or full radius rolled Safety Edge** to help you work more comfortably.

BENCH DRAWER. 18"W x 24"D x 5 1/4"H
SC606964A

KEYED PADLOCK SC432248A

SQUARE EDGE BENCH

	PLASTIC	SHOP TOP	MAPLE	ESD
W" x D"	Model	Model	Model	Model
60 x 30	SC778460	SC778468	SC778476	SC778484
60 x 36	SC778461	SC778469	SC778477	N/A
72 x 30	SC778377	SC778361	SC778393	SC778321
72 x 36	SC778324	SC778342	SC778325	SC778353
96 x 30	SC778379	SC778363	N/A	N/A
96 x 36	SC778326	SC778344	SC778327	N/A

Safety Edge BENCH

	PLASTIC	MAPLE	ESD
W" x D"	Model	Model	Model
60 x 30	SC778488	SC778496	SC250228
72 x 30	SC778107	SC778123	SC250229
72 x 36	SC778108	SC778124	SC250230

PREMIUM MODULAR WORKBENCH

Superior Quality For Years Of Dependability!

Premium quality modular workbenches allow you to choose the bench that best fits your needs. Strong, all welded steel construction is tough enough for any application. Choose from seven pedestal configurations plus eight top styles. Inside drawer dimensions are 13"W x 17³/₄"D x 5¹/₂"H (12"H for the lower drawer on the three drawer pedestal). Cabinet pedestal features adjustable shelf and cylinder lock. Pedestal dimensions are 15³/₄"W x 20"D x 32"H.



Drawers glide on nylon rollers and feature full-length aluminum pulls and individual cylinder locks.

Style	Description
A. 1-4	DRAWER PEDESTAL
B. 1-3	CABINET PEDESTAL
C. 1-3	DRAWER PEDESTAL
D. 1-3	CABINET PEDESTAL
E. 2-4	DRAWER PEDESTAL
F. 1-4	DRAWER PEDESTAL
G. 1-4	DRAWER PEDESTAL

OPTIONAL POWER RISER

Includes grounded eight outlet wiring kit, circuit breaker, pilot light, 8'L grounded cord and plug. 15 amps, 115V. 18"H x 15"D.

Model	W"
SC607701	60
SC607702	72



SC607617

APRON POWER CENTER

36"W panel includes circuit breaker with 8 grounded outlets, pilot light, 8'L grounded cord and plug. For use with 72"W benches, except style F.

Model SC249512



W" x D"	Model	Model	Model	Model	Model	Model	Model
MAPLE-1³/₄" Thick Top							
60 x 24	SC253776	SC253780	SC253784	SC253788	SC253792	---	SC253800
60 x 30	SC607616	SC607628	SC607640	SC607652	SC607664	SC607676	SC607688
72 x 24	SC253777	SC253781	SC253785	SC253789	SC253793	---	SC253801
72 x 30	SC607617	SC607629	SC607641	SC607653	SC607665	SC607677	SC607689
PLASTIC-1⁵/₈" Thick Top							
60 x 24	SC253778	SC253782	SC253786	SC253790	SC253794	---	SC253802
60 x 30	SC607618	SC607630	SC607642	SC607654	SC607666	SC607678	SC607690
72 x 24	SC253779	SC253783	SC253787	SC253791	SC253795	---	SC253803
72 x 30	SC607619	SC607631	SC607643	SC607655	SC607667	SC607679	SC607691
ESD -1¹/₄" Thick Top							
60 x 30	SC607620	SC607632	SC607644	SC607656	SC607668	SC607680	SC607692
72 x 30	SC607621	SC607633	SC607645	SC607657	SC607669	SC607681	SC607693
SHOP TOP-1¹/₂" Thick Top							
60 x 30	SC300733	SC300735	SC300737	SC300739	SC300741	SC300743	SC300745
72 x 30	SC300734	SC300736	SC300738	SC300740	SC300742	SC300744	SC300746
Safety Edge BENCH							
MAPLE SAFETY EDGE-1³/₄" Thick Top							
60 x 30	SC607622	SC607634	SC607646	SC607658	SC607670	SC607682	SC607694
72 x 30	SC607623	SC607635	SC607647	SC607659	SC607671	SC607683	SC607695
PLASTIC SAFETY EDGE-1⁵/₈" Thick Top							
60 x 30	SC607624	SC607636	SC607648	SC607660	SC607672	SC607684	SC607696
72 x 30	SC607625	SC607637	SC607649	SC607661	SC607673	SC607685	SC607697
ESD SAFETY EDGE-1¹/₄" Thick Top							
60 x 30	SC607626	SC607638	SC607650	SC607662	SC607674	SC607686	SC607698
72 x 30	SC607627	SC607639	SC607651	SC607663	SC607675	SC607687	SC607699
SHOP TOP-1³/₄" Thick Top							
60 x 30	SC300747	SC300749	SC300751	SC300753	SC300755	SC300757	SC300759
72 x 30	SC300748	SC300750	SC300752	SC300754	SC300756	SC300758	SC300760

PROLINE HEAVY DUTY BENCHES

Sturdy four leg design provides stability and strength. Table top is reinforced using a metal perimeter around the frame. Bench is made using heavy 2" x 2" 16 gauge steel tube legs with high quality paint finish. Legs include PVC boots to protect station during clean ups. 1,000 lb. capacity. Bench top is available in Stainless Steel, Epoxy Resin or Black Chem-Guard (chemical resistant laminate).

W" x D" x H"	Top Construction	Color	Model
60 x 30 x 32	Chem Guard Square Edge	White	SC249756
60 x 30 x 30	Stainless Steel Square edge	White	SC249758
60 x 30 x 34	Phenolic Resin Square Edge	White	SC249757

Perfect For Lab and Shop Use



ANTI-STATIC WORKSURFACE MATS

- Excellent for use in assembly operations where matting may come in contact with hot soldering iron tips or solder splashes
- Volume electrical properties protect static sensitive products
- Static dissipative top layer with a conductive bottom of synthetic rubber
- Slight stipple finish, RTT: 10E8 ohms, Thickness: 0.078", Blue color
- Includes one installed 10mm snap socket
- **Optional Hardware Kit** includes: wrist strap, common point ground and mat hardware kit to ground workers for safety

Model	Description
SC242251	2' x 3' Mat
SC242252	2' x 4' Mat
SC242253	Hardware Kit



SC242253



01-800-467-0529

chproductos.com

155

VERSATILE, DURABLE WORKBENCHES...UNBEATABLE PERFORMANCE

A Good Bench Creates A Good Worker!

Steel open leg frames feature 2 electrical knockouts that accept installation of duplex outlets for electrical wiring or optional plug-in outlet that easily screws in place with no wiring necessary. 3"W steel legs with channel construction for extra strength. These industrial workbenches include a full width lateral brace for added reinforcement. Legs and stringer are finished in gray baked enamel for rust and scratch resistance. **Height Adjustable Legs** adjust from 27⁷/₈" to 35¹/₂"H at 1¹/₂" increments for proper work height positioning for any user. Our bench top selection is perfect for any environment!

PLASTIC TOP Super Strong...Easy Clean

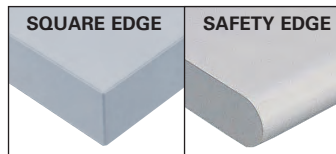

High pressure plastic laminate with wood-core withstands heavy abuse. Provides a smooth, tough work surface for any application. 1⁵/₈" thick light gray plastic top.



**FLARED
FIXED LEG 32"**

**ADJUSTABLE
HEIGHT LEG**
27⁷/₈" - 35¹/₂"

SELF CONTAINED DUAL SIDED OUTLET provides easy access to electrical power on both front and back sides. 15 ft. Power cord. Rated at 15 Amp and 115V. Model **SC249854**



**DUAL SIDED
OUTLET**

W" x D"	FLARED FIXED LEG Model	ADJUSTABLE HEIGHT LEG Model
SQUARE EDGE		
48 x 30	SC601418	SC601419
60 x 30	SC601420	SC601421
60 x 36	SC601422	SC601423
72 x 30	SC601424	SC601425
72 x 36	SC601426	SC601427
96 x 30	SC601428	SC601429
96 x 36	SC601430	SC601431
SAFETY EDGE		
60 x 30	SC183981	SC183990
72 x 30	SC183982	SC183991
72 x 36	SC183983	SC183992



**FLARED
FIXED LEG 32"**

**ADJUSTABLE
HEIGHT LEG**
27⁷/₈" - 35¹/₂"

STATIC FREE WRIST STRAP helps protect sensitive electronic components. Alligator clip attaches to any grounding object. Model **SC381000**



**FLARED
FIXED LEG 32"**

**ADJUSTABLE
HEIGHT LEG**
27⁷/₈" - 35¹/₂"

CASTER KIT
Includes 2 swivel (w/brakes),
2 rigid casters, mounting
brackets and hardware.



ESD TOP Protects Equipment from Harmful Static!

Conductive white plastic top dissipates 5000 volts of static electricity in .01 seconds with a surface resistance of 10¹⁰ Ohms. 1¹/₄" thick top prevents damage to sensitive electronic circuitry during assembly. Cleans easily. Complies MIL-B817058 and 101B, 101C Method 4046.



W" x D"	FLARED FIXED LEG Model	ADJUSTABLE HEIGHT LEG Model
SQUARE EDGE		
48 x 30	SC237343	SC237344
60 x 30	SC252384	SC254960
72 x 30	SC252385	SC254968
72 x 36	SC252386	SC254966
SAFETY EDGE		
48 x 30	SC237345	SC237346
60 x 30	SC250222	SC250225
72 x 30	SC250223	SC250226
72 x 36	SC250224	SC250227

STEEL TOP Super Strong Steel Won't Crack or Buckle



Made of 12 gauge steel for heavy duty use in industrial applications. 1³/₄" thick top is reinforced with 14 gauge end channels for additional strength and durability. Gray baked enamel finish is rust resistant and won't absorb oils and lubricants.

W" x D"	FLARED FIXED LEG Model	ADJUSTABLE HEIGHT LEG Model
48 x 30	SC183400	SC183150
48 x 36	SC183402	SC183151
60 x 30	SC183404	SC183152
60 x 36	SC183406	SC183153
72 x 30	SC183408	SC183154
72 x 36	SC183410	SC183155

MAPLE-BUTCHER BLOCK TOP

Solid, 1³/₄" thick rugged top stands up to constant, heavy use. Maple butcher block top is kiln dried, electronically glued, sanded smooth and finished with a penetrating oil protectant for a high quality appearance.

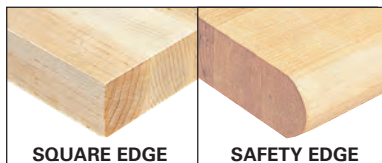

SQUARE EDGE

SAFETY EDGE

W" x D"	FLARED FIXED LEG Model	ADJUSTABLE HEIGHT LEG Model
SQUARE EDGE		
48 x 30	SC183427	SC183149
60 x 30	SC183428	SC183166
60 x 36	SC183430	SC183167
72 x 30	SC183432	SC183168
72 x 36	SC183434	SC183169
96 x 36	SC183436	SC183179
SAFETY EDGE		
60 x 30	SC183978	SC183987
72 x 30	SC183979	SC183988
72 x 36	SC183980	SC183989



DUAL SIDED OUTLET

SHOP TOP *Non-Conductive, Non-Warping*

One of the toughest industrial tops available. Shop Top bench top protects against static build-up and won't warp or split. Shop top is faced on two sides with ³/₈" thick high grade, high density particleboard sealed with a catalyzed finish to resist liquids. Strong MDF core. Choose between 1¹/₂" thick Square Edge or 1³/₄" thick Safety Edge.

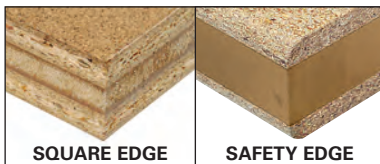

SQUARE EDGE

SAFETY EDGE

W" x D"	FLARED FIXED LEG Model	ADJUSTABLE HEIGHT LEG Model
SQUARE EDGE		
48 x 30	SC183439	SC183139
60 x 30	SC183440	SC183162
60 x 36	SC183442	SC183163
72 x 30	SC183444	SC183164
72 x 36	SC183446	SC183165
96 x 30	SC183447	SC183170
96 x 36	SC183448	SC183172
SAFETY EDGE		
60 x 30	SC183975	SC183984
72 x 30	SC183976	SC183985
72 x 36	SC183977	SC183986

ASH BUTCHER BLOCK TOP *Stands Up To Constant, Heavy Use*

Heavy duty, good-looking top at an affordable price. 1³/₄" thick Ash Butcher Block top is kiln dried, electronically glued and sanded smooth for a high quality appearance. Penetrating mineral oil protectant finish resists moisture and won't absorb oil and lubricants.



SAFETY EDGE

W" x D"	FLARED FIXED LEG Model	ADJUSTABLE HEIGHT LEG Model
60 x 30	SC579113	SC579116
72 x 30	SC579114	SC579117
72 x 36	SC579115	SC579118

STAINLESS STEEL TOP *Corrosion Resistant*

Made of Type 304, 16 gauge stainless steel. 1¹/₂" thick top features a durable particle board core with phenolic backer for use in **clean rooms and food service environments**. Stainless edges are welded and polished on the corners with a #4 brushed finish.



SQUARE EDGE

W" x D"	FLARED FIXED LEG Model	ADJUSTABLE HEIGHT LEG Model
48 x 30	SC239121	SC239124
60 x 30	SC239122	SC239125
72 x 30	SC239123	SC239126



ADJUSTABLE HEIGHT LEG
27⁷/₈" - 35¹/₂"



FLARED FIXED LEG 32"

SELF CONTAINED DUAL SIDED OUTLET provides easy access to electrical power on both front and back sides. 15 ft. Power cord. Rated at 15 Amp and 115V.

Model
SC249854



ADJUSTABLE HEIGHT LEG
27⁷/₈" - 35¹/₂"



FLARED FIXED LEG 32"



ADJUSTABLE HEIGHT LEG
27⁷/₈" - 35¹/₂"



FLARED FIXED LEG 32"



ADJUSTABLE HEIGHT LEG
27⁷/₈" - 35¹/₂"



FLARED FIXED LEG 32"

CASTER KIT Includes 2 swivel (w/brakes), 2 rigid casters, mounting brackets and hardware.



CUSTOMIZE YOUR BENCH WITH QUALITY COMPONENTS



SC606961
SHOWN WITH
DOLLY BASE
SC607728



SC606960



SC606959



SC242266GYM



BENCH VISE



SC273116GYM

PREMIUM WORKBENCH PEDESTALS with built-in base. Combine any of our strong, all welded steel workbench pedestals and stacking drawers to create the ideal workstation for your application. All drawers feature full-length aluminum extrusion handle. Drawer glides smoothly on nylon rollers and includes an individual cylinder lock. Inside pedestal drawer dimensions are 13"W x 17³/₄"D x 5¹/₂"H (12"H for the lower drawer on the three drawer pedestal). Cabinet pedestal features adjustable shelf and cylinder lock. Pedestal dimensions are 15³/₄"W x 20"D x 32"H. Durable gray powder coat finish. Add dolly base with 4" swivel casters (2-locking) to create a mobile tool and parts toter Model **SC607728**.

PEDESTAL AND BASE

Model	Description
SC606961	4 Drawer Pedestal
SC606959	Cabinet Pedestal
SC606960	3 Drawer Pedestal
SC607728	Dolly Base

LOCKING CABINET PEDESTAL Includes built-in base, adjustable shelf and three point locking handle. 13¹/₂"W x 23¹/₂" D x 32" H. Not for use with electronic lock.

SC706640 (Not Shown)

STANDARD DRAWER 18¹/₄"W x 23⁷/₈"D x 5³/₈"H. Includes hasp. Not for use with electronic lock.

SC606964B

CYLINDER LOCK Locks pedestal for security
SC254712A

STACKING DRAWERS includes cylinder lock.

Model	W" x D" x H"
SC242266GY	17 ¹ / ₄ x 20 x 6 ¹ / ₂
SC242267GY (Not Shown)	17 ¹ / ₄ x 20 x 11 ³ / ₄

STORAGE CABINET 17¹/₄"W x 20"D x 16"H

with removable center shelf, recessed handle and cylinder lock. Mounts with hinge door on right or left. SC273116GY

BENCH VISE Swivels 90°, 5" jaw opening, 4"W.
SC292204B



POWER
APRON

POWER APRON Steel 36"W panel fits between pedestals and includes circuit breaker with 8 outlets, pilot light, 8' ft. cord and plug. Convenient 36"W x 10"D lower shelf. Fits 72" and 96" wide benches. 15 amps, 115V.

Model SC254756

Drawers glide on nylon rollers and feature full-length aluminum pulls and individual cylinder locks.

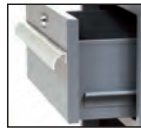

Gray Baked Enamel Finish



Built In Base

BENCH RISER 10¹/₂"D x 12"H with 2" backstop.

Model	Width"
SC254740	48
SC254742	60
SC254744	72
SC706438A	96



POWER RISER

RISER WITH POWER CENTER 18"H x 15"D includes eight outlets and wiring kit with circuit breaker, pilot light, 8 ft. cord and plug. 15 amps, 115V.

Model	Width"
SC254753B	60
SC254754B	72
SC254755B	96

BACK & END STOPS Extends 3" above top.

Model	W" x D"
SC254714	48 x 30
SC254716A	48 x 36
SC254718	60 x 30
SC254720	60 x 36
SC254722	72 x 30
SC254724	72 x 36

ELECTRIC STRIP-48"L (15 AMP-120V) 15 ft. cord

Model	Description
SC190322G	8 Outlets
SC190323G	16 Outlets

BACK & END STOPS

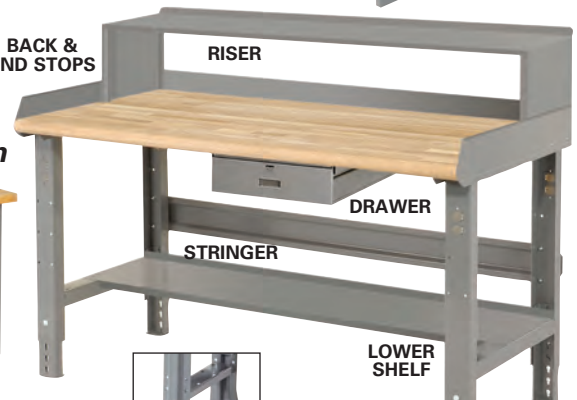

RISER

DRAWER

STRINGER

LOWER SHELF



FLARED
FIXED LEG

ADJUSTABLE HEIGHT LEG
27⁷/₈" - 35¹/₂"

BENCH LEGS Both leg styles are 13 gauge and feature double electrical knock outs, front and back. Legs are punched for tops, stringers and shelf attachment.

Model	Depth"	Height"
ADJUSTABLE HEIGHT LEG 1 ¹ / ₂ " increments.		
SC249507	30	27 ⁷ / ₈ -35 ³ / ₈
SC249508	36	27 ⁷ / ₈ -35 ³ / ₈

FIXED HEIGHT LEG

SC254746	30	28
SC254748	36	28
SC254750	30	32
SC254752	36	32

STRINGER Helps increase bench stability. 6" W steel channel easily attaches to legs. Not for use with pedestals.

Model	Width"
SC255220	48
SC255221	60
SC255222	72
SC706442	96

LOWER SHELF with 2" backstop.

Model	W" x D"
SC254726	48 x 15
SC254728	60 x 15
SC254730	72 x 15
SC300909*	96 x 15

*96" W Lower shelf requires a third leg.
*Also use (2) 48" lower shelves.

CHOOSE SQUARE EDGE OR ERGONOMIC SAFETY EDGE BENCH TOPS

MAPLE



Maple butcher block is kiln dried, electronically glued, cured and sanded smooth. Finished with a penetrating mineral oil protectant. Available in two styles: standard 1 3/4" or extra strong 2 1/4" thick.

W"x D"	1 3/4" THICK Model	2 1/4" THICK Model
48 x 30	SC601148	N/A
48 x 36	SC607286	N/A
60 x 30	SC601150	SC601782
60 x 36	SC601152	N/A
72 x 30	SC601154	SC601783
72 x 36	SC601156	SC601784
96 x 30	SC607287	N/A
96 x 36	SC601180	N/A

MAPLE SAFETY EDGE



Solid maple strips are glued together and electronically cured. The top is kiln dried, sanded smooth and finished with a penetrating oil protectant. Rounded front safety edge protects workers from leaning against sharp edges. 1 3/4" thick.

Model	W"x D"
SC607283	48 x 30
SC607284	48 x 36
SC601367	60 x 30
SC607285	60 x 36
SC601368	72 x 30
SC601369	72 x 36

BIRCH SQUARE EDGE



Birch Tops kiln dried, glued and sanded smooth. All tops are treated with mineral oil to protect from drying. These are economical all-purpose bench tops for general purpose applications.

W"x D"	Model
48 x 30	SC318849
48 x 36	SC318853
60 x 30	SC318850
60 x 36	SC318854
72 x 30	SC318851
72 x 36	SC318855
96 x 30*	SC318856
96 x 36*	SC318856

*3500 lb. capacity

ASH SAFETY EDGE



Ash butcher block top is kiln dried, sanded smooth and finished with a penetrating oil protectant to make a heavy-duty, good-looking and affordable work surface. Rounded front safety edge protects workers. 1 3/4" thick.

Model	W"x D"
SC651464	60 x 30
SC300914	60 x 36
SC651465	72 x 30
SC651466	72 x 36

PHENOLIC RESIN



Chemical resistant bench tops are great for use in laboratories. Made of 1" thick black phenolic resin that withstands moisture and resists chemicals. Impact resistant for superior strength. Rounded front Safety Edge.

Model	W"x D"
SC237388	60 x 30
SC237390	60 x 36
SC237392	72 x 30
SC237394	72 x 36

ESD

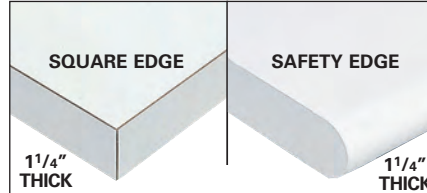

Prevents damage to sensitive electronic circuitry during assembly. White plastic top dissipates 5000 volts of static electricity in .01 seconds. Cleans easily. Complies MIL-B817058 and 101B, 101C Method 4046. 1 1/4" thick.

W"x D"	Model	Model
48 x 30	SC651448	SC250213
48 x 36	SC607282	SC607281
60 x 30	SC255217	SC250214
60 x 36	SC651449	SC250215
72 x 30	SC255218	SC250216
72 x 36	SC255219	SC250217
96 x 30	SC607292	NA
96 x 36	SC607293	NA

PLASTIC

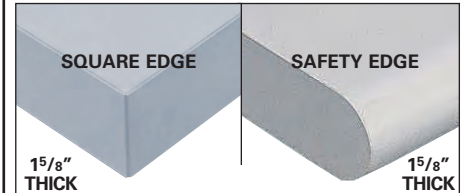

Super-strong, easy to clean, high pressure plastic laminate-faced wood core takes heavy abuse. Serves as a smooth, tough working surface for many applications. 1 5/8" thick.

W"x D"	Model	Model
48 x 30	SC601149	SC607289
48 x 36	SC607291	SC607290
60 x 30	SC601166	SC601364
60 x 36	SC601168	SC579311
72 x 30	SC601170	SC601365
72 x 36	SC601172	SC601366
96 x 30	SC601174	NA
96 x 36	SC601176	NA

STEEL

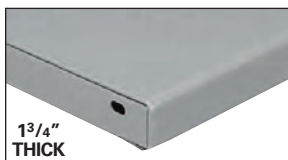

Steel bench tops won't crack or buckle. 12 gauge steel top with heavy duty flanged construction for extra strength. 1 3/4" thick top. Includes stringer for easy connection to bench legs.

W"x D"	Model
48 x 30	SC185718
48 x 36	SC185719
60 x 30	SC185720
60 x 36	SC185721
60 x 36	SC185721BK
72 x 30	SC185722
72 x 30	SC185722BK
72 x 36	SC185723

STAINLESS STEEL

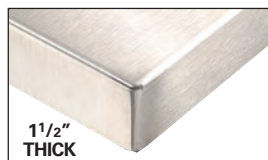

1 1/2" Thick durable particle board core with a phenolic backer wrapped with 16 gauge, type 304 stainless steel. Tops have stainless edges and are welded and polished on the corners with a #4 brushed finish. Wood core allows for easy installation over cabinets and can be used with most bench legs.

Model	W"x D"
SC239118	48 x 30
SC239119	60 x 30
SC239120	72 x 30

SHOP TOP

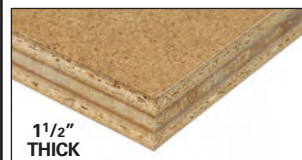

Square edge top is faced on two sides with 3/8" thick high grade, high density particleboard sealed with a catalyzed finish to resist liquids. Super strong MDF core. Overall 1 1/2" thick.

Model	W"x D"
SC601157	48 x 30
SC601158	60 x 30
SC601160	60 x 36
SC601162	72 x 30
SC601164	72 x 36
SC601165	96 x 30
SC601167	96 x 36

SHOP TOP SAFETY EDGE

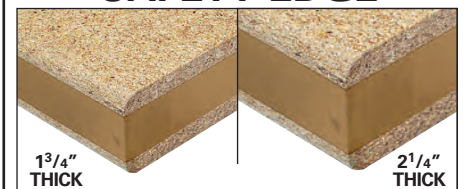

Safety radius edge top is faced on two sides with 3/8" thick high grade, high density particleboard sealed with a catalyzed finish to resist liquids. Super strong MDF core. Choose between 1 3/4" top and 2 1/4" top.

W"x D"	Model	Model
48 x 30	SC607288	NA
60 x 30	SC601361	SC601785
72 x 30	SC601362	SC601786
72 x 36	SC601363	SC601787



5000 lb. capacity!

Power apron provides an electric source for power tools and other electric equipment. High quality benches are made strong with rugged 2" square x 14 gauge tubular steel **height adjustable legs**. Legs adjust from 28-34"H at 2" increments. Tested to withstand **5000 lb. capacity (4000 lb. for 96"W benches)**. Pre-wired power apron includes 3 duplex 15 amp/115V outlets, circuit breaker and 13'L quick-disconnect power cord. Includes adjustable leveling floor glides and leveling foot plates that allow floor anchoring. 15 Year Limited Warranty. Choose between **Plastic** tops which are high pressure laminate that withstand daily use, and **ESD** tops which dissipate 5000 volt static charge in .01 seconds with surface resistance of 10¹⁰ Ohms and provides protection against static electricity. Available in standard **Square Edge** or **Safety Radius Edge**. Blue or Tan powder coat finish. Quick and easy assembly. Add stackable steel drawer with cylinder lock for convenient storage. Note: Upright Kit accepts installation of Upright Shelf, Shelf with pre-wired electric, LCD Monitor Arm, Light Kit, Bin Rail and Pegboard & Louver Panels (*Panels require Mounting Kit). Specify color suffix: Blue (BL) or Tan (TN).

HEAVY DUTY ELECTRONIC PRODUCTION BENCH



W" x D"	BASIC BENCH WITH BENCH TOP			
	PLASTIC SQUARE EDGE Model	PLASTIC SAFETY EDGE Model	ESD SQUARE EDGE Model	ESD SAFETY EDGE Model
48 x 30	SC606974B	SC606998B	SC606990B	SC607263B
48 x 36	SC606975B	SC606999B	SC606991B	SC607264B
60 x 24	SC249185B	---	---	---
60 x 30	SC606976B	SC607000B	SC606992B	SC607265B
60 x 36	SC606977B	SC607001B	SC606993B	SC607266B
72 x 24	SC249186B	---	---	---
72 x 30	SC606978B	SC607002B	SC606994B	SC607267B
72 x 36	SC606979B	SC607003B	SC606995B	SC607268B
96 x 30*	SC606980B	---	SC606996B	---
96 x 36*	SC606981B	---	SC606997B	---

*3500 lb. capacity



MOBILE HEAVY DUTY PRODUCTION BENCH

2000 lb. capacity!

Easily transport your workbench where you need it! Built to last using rugged 2" sq. x 14 gauge tubular steel legs that are 36"H. **2000 lb. capacity**. Includes 15"D lower shelf with backstop for added storage space. Moves easy on 5" phenolic swivel casters with brakes. 15 Year Limited Warranty. Choose between 6 bench top options available in **Square Edge** or **Safety Radius Edge**. Quick and easy assembly. Add Optional Accessories. **Stackable Steel Drawer** or **Storage Cabinet** with cylinder lock for convenient under bench storage 17 1/4"W x 20"D. **Pre-Wired Power Apron** provides a convenient power source for electric equipment. **48"H Upright Kit** includes 12"D shelf. Note: Upright Kit accepts installation of Upright Shelf, Shelf with pre-wired electric, LCD Monitor Arm, Light Kit, Bin Rail, and Pegboard & Louver Panels (*Panels require Mounting Kit). Both optional 120v electrical strips are 48"L with 15' cord. Durable powder coat finish. Specify color suffix: Blue (BL) or Tan (TN).



HEAVY DUTY

Model	Description
SC432210A	48"H Upright Kit with 12"D Shelf for 60"W Bench
SC432211A	48"H Upright Kit with 12"D Shelf for 72"W Bench
SC606946A	Upright Shelf 12"D x 60"W
SC606947A	Upright Shelf 12"D x 72"W
SC607270A	Light Kit- 60"
SC607271A	Light Kit- 72"
SC249295A	60" Pre-wired Shelf with Electric
SC249296A	72" Pre-wired Shelf with Electric
SC606942A	Bin Rail 60"W (Pages 4-14 for a selection of bins)
SC606943A	Bin Rail 72"W (Pages 4-14 for a selection of bins)
SC249292A	60" Mounting Kit for 60" Bench
SC249293A†	72" Mounting Kit for 72" Bench
SC249286A*	18 x 19 Pegboard Panel
SC249287A*	36 x 19 Pegboard Panel
SC606968C	30 pcs. Assorted Pegboard Hook Set
SC249288A*	18 x 19 Louver Panel
SC249289A*	36 x 19 Louver Panel
SC249624	LCD Monitor Arm (Requires Upright Kit)

*Requires Upright and Mounting Kit
†Holds one 36" and one 18" Panel, does not accept two 36" Panels.

W" x D"	PLASTIC 1 5/8"	MAPLE 1 3/4"	ESD 1 1/4"	SHOP TOP 1 1/2"	PHENOLIC RESIN 1"	304 STAINLESS 1 1/2"
	Model	Model	Model	Model	Model	Model
BASIC MOBILE BENCH WITH SQUARE EDGE BENCH TOP						
60 x 30	SC253972	SC253975	SC253978	SC253998	---	SC253984
72 x 30	SC253973	SC253976	SC253979	SC253999	---	SC253985
72 x 36	SC253974	SC253977	SC253980	SC254000	---	---
BASIC MOBILE BENCH WITH SAFETY EDGE BENCH TOP						
60 x 30	SC253986	SC253989	SC253992	SC249145*	SC253995	---
72 x 30	SC253987	SC253990	SC253993	SC249146*	SC253996	---
72 x 36	SC253988	SC253991	SC253994	SC249147*	SC253997	---

* Safety Edge Shop Top is 1 3/4" thick.
PRE-WIRED POWER APRON: Includes three duplex outlets, circuit breaker, switch 15 amps/115 volts, 13' cord.

EXTRA HEAVY DUTY SECURITY CABINET BENCHES



SHOWN WITH
OPTIONAL
CENTER SHELF

5000 lb. capacity!

SC253948

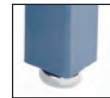

BENCH LEGS
INCLUDE FOOT
PLATES AND
GLIDES

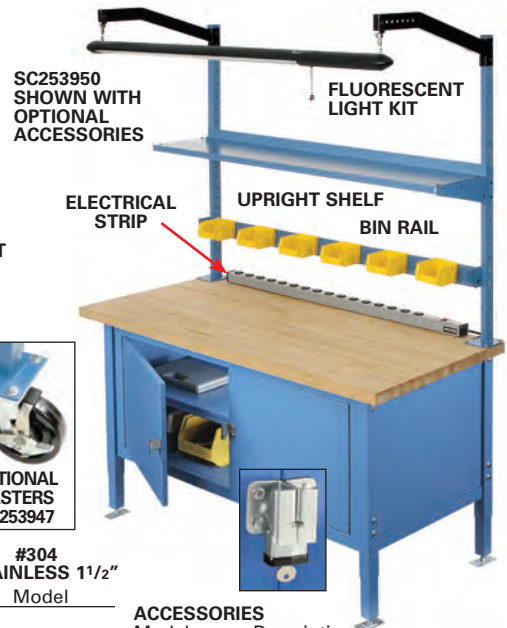

SC253950
SHOWN WITH
OPTIONAL
ACCESSORIES

FLUORESCENT
LIGHT KIT

ELECTRICAL
STRIP

UPRIGHT SHELF

BIN RAIL



OPTIONAL
CASTERS
SC253947

Enclosed Cabinet bench provides security for all your under bench storage needs. High quality, industrial work benches are made to last using rugged 2" square, 14 gauge tubular steel legs that are height adjustable 28-34"H at 2" increments. **5000 lb. capacity. Cut resistant padlockable hasp for security.** Interior compartment measures 25 1/2"D x 22"H. Includes adjustable leveling floor glides and leveling foot plates that allow floor anchoring. Offers clearance space under cabinet. 15 Year Limited Warranty. Available in **Plastic, Maple, Shop Top, ESD, Phenolic Resin or Stainless Steel** bench tops. Choose between standard **Square Edge** and **Safety Radius Edge**. Blue or Tan powder coat finish. Customize using **Optional Accessories** (sold separately); including a **Center Shelf** for added storage. **Casters** allow mobility to workbench with 2000 lb. capacity. **Upright Kit** attaches to bench top to provide overhead storage with included 12"D cantilever shelf. **Note:** Upright Kit accepts installation of Upright Shelf, Shelf with pre-wired electric, Light Kit, LCD Monitor Arm, Bin Rail, and Pegboard & Louver Panels (*Panels require **Mounting Kit**). Quick and easy assembly. **Specify Color Suffix:** Blue (BL) or Tan (TN).

W" x D"	PLASTIC 1 5/8" Model	MAPLE 1 3/4" Model	ESD 1 1/4" Model	SHOP TOP 1 1/2" Model	PHENOLIC RESIN 1" Model	#304 STAINLESS 1 1/2" Model
			SQUARE EDGE BENCH TOP			
60 x 30	SC253948	SC253950	SC253952	SC253954	---	SC253958
72 x 30	SC253949	SC253951	SC253953	SC253955	---	SC253959
			SAFETY EDGE BENCH TOP			
60 x 30	SC253960	SC253962	SC253964	SC253966	SC253968	
72 x 30	SC253961	SC253963	SC253965	SC253967	SC253969	

ACCESSORIES	
Model	Description
SC253970	60" Cabinet Center Shelf
SC253971	72" Cabinet Center Shelf
SC253947	5" Phenolic Swivel Casters with Brakes
SC336375Z	Padlock
SC249624*	LCD Monitor Arm
*LCD Monitor Arm requires Upright Kit	

*Safety Edge Shop Top is 1 3/4" thick.

HEAVY DUTY LAB BENCH 5000 lb. capacity!

This top quality lab bench is supported by heavy duty 2" square legs made of 14 gauge tubular steel. Legs are height adjustable 28-34"H at 2" increments making it ideal for schools and laboratories. Available in **Plastic, Phenolic Resin and Stainless Steel** bench tops. Tops are available with either a **Square Edge** or a **Safety Radius Edge**. Base has a scratch resistant powder coat finish. Customize using **Optional Accessories** (sold separately). Add **Stacking Steel Drawer or Storage Cabinet** with cylinder lock for storage that easily installs under workbench. **Pre-Wired Power Apron** provides a convenient power source for electric equipment. **Upright Kit** includes a 12"D Upright Shelf. **Note:** Upright Kit accepts installation of Upright Shelf, Shelf with pre-wired electric, Light Kit, LCD Monitor Arm, Bin Rail and Pegboard & Louver Panels (*Panels require **Mounting Kit**). Quick and easy assembly. 15 Year Limited Warranty! **Specify color suffix:** Blue (BL) or Tan (TN).



SC237381
SHOWN WITH
OPTIONAL
ACCESSORIES



LIGHT KIT

UPRIGHT SHELF

UPRIGHT KIT

BIN RAIL

STACKING DRAWER

BENCH ACCESSORIES

Model	Description
SC606950A	Lower Steel Shelf - 60"W x 15"D
SC606951A	Lower Steel Shelf - 72"W x 15"D
	Use with 24"D Bench
SC249382A	Stacking Drawer - 17 1/4"W x 20"D x 6"H
SC249383A	Stacking Drawer - 17 1/4"W x 20"D x 12"H
SC249384A	Storage Cabinet 17 1/4"W x 20"D x 16"H
	Use with 30"D Bench
SC249378	Stacking Drawer - 17 1/4"W x 20"D x 6"H
SC249379	Stacking Drawer - 17 1/4"W x 20"D x 12"H
SC249385A	Storage Cabinet 17 1/4"W x 20"D x 16"H
	Use with 36"D Bench
SC249380	Stacking Drawer - 17 1/4"W x 20"D x 12"H
SC249381	Stacking Drawer - 17 1/4"W x 20"D x 12"H
SC249386A	Storage Cabinet 17 1/4"W x 20"D x 16"H
SC190322C	8 Outlets - Electric Strip (120V) 48"L - 15 ft. cord
SC190323A	16 Outlets - Electric Strip (120V) 48"L - 15 ft. cord

PRE-WIRED POWER APRON: Includes three duplex outlets, circuit breaker, switch 15 amps/115 volts, 13' cord.

BENCH LEGS INCLUDE FOOT PLATES AND GLIDES

W" x D"	SAFETY EDGE BENCH TOP	
	PLASTIC TOP 1 5/8" Thick Model	PHENOLIC RESIN TOP 1" Thick Model
60 x 30	SC237375	SC237383L
60 x 36	SC237376	SC237384L
72 x 30	SC237377	SC237385L
72 x 36	SC237378	SC237386L

SQUARE EDGE BENCH TOP

W" x D"	SQUARE EDGE BENCH TOP	
	PLASTIC TOP 1 5/8" Thick Model	STAINLESS 1 1/2" Thick W" x D" Model
60 x 24	SC249201	60 x 30 SC249402
60 x 30	SC237371	72 x 30 SC249403
60 x 36	SC237372	
72 x 24	SC249202	
72 x 30	SC237373	
72 x 36	SC237374	

PRE-WIRED POWER APRON: Includes three duplex outlets, circuit breaker, switch 15 amps/115 volts, 13' cord.

BENCH
WITH MAPLE TOP

HEAVY DUTY

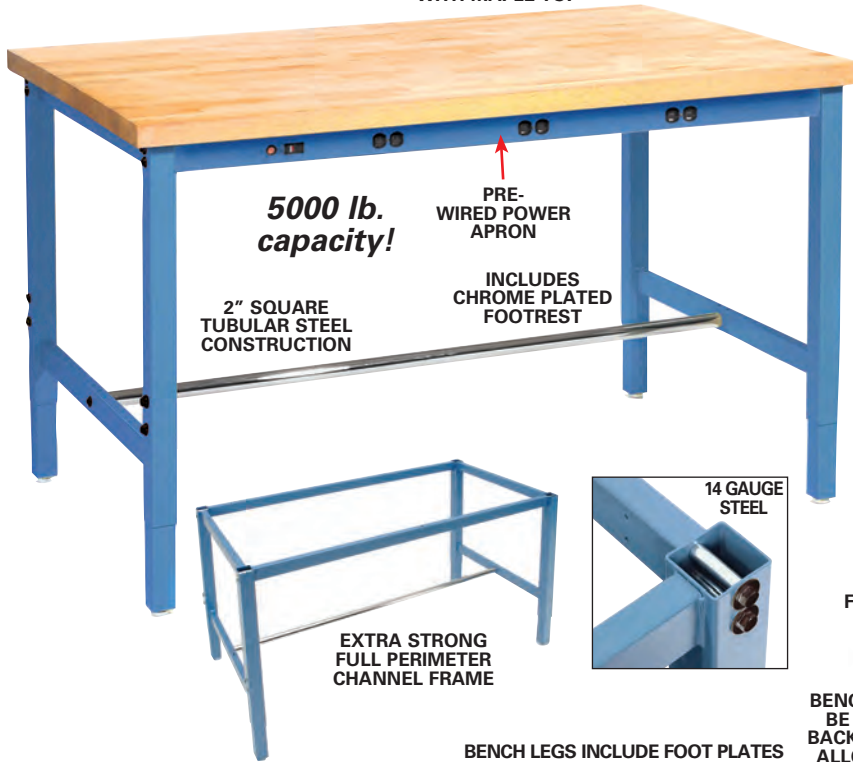

Long lasting, high quality benches are made strong with 2" square, 14 gauge tubular steel legs that are height adjustable at 2" increments from 28-34"H. Withstands up to 5,000 lb. capacity (96" has 4,000 lb. capacity). Includes adjustable leveling floor glides and leveling foot plates that allow floor anchoring. Quick and easy assembly. Available in Blue or Tan powder coat finish. 15 Year Limited Warranty. Choose between 6 tops: **Plastic** tops are high pressure laminate that withstand daily use, all-purpose **Maple** tops are kiln-dried, electronically glued and sanded smooth, **ESD** tops provide protection against static electricity, **Phenolic Resin** tops offer excellent chemical resistance ideal for lab use, **Shop Top** protects against static build-up and won't warp or split, and **Stainless Steel** tops have 1/2" thick durable particle board core with a phenolic backer wrapped with 16 gauge, type 304 stainless steel. Tops are available in standard **Square Edge** or **Safety Radius Edge**. Optional accessories create a completely customizable workstation. **Tool Balancer** conveniently holds tools up to 10 lbs. (requires tool balancer track kit). **Pre-Wired Power Apron** provides a convenient power source for electric equipment. Add **Stacking Steel Drawer** or **Storage Cabinet** with cylinder lock for storage that easily installs under workbench. **Upright Kit** allows easily accessory attachment and includes a 12"D **Upright Shelf**. **Specify Color Suffix: Blue (BL) or Tan (TN)**.

Note: Upright Kit accepts installation of **Tool Balancer Kit** Upright Shelf, Pre-wired shelf with electric, Light Kit, Bin Rail, and Pegboard & Louver Panels (*Panels require **Mounting Kit**).



EXTRA STRONG
FULL PERIMETER
CHANNEL FRAME



14 GAUGE
STEEL

FLUORESCENT
LIGHT KIT

UPRIGHT SHELF



BENCHES CAN
BE PLACED
BACK TO BACK
ALLOWING A
CONTINUOUS
WORK
SURFACE

UPRIGHT
KIT

Note: Upright shelf,
light kit and bin rail
require purchase of
upright kit.

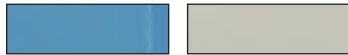

Available in Blue or Tan powder coat finish.
Specify color suffix: **Blue (BL)** or **Tan (TN)**.

BENCH LEGS INCLUDE FOOT PLATES
AND GLIDES



AVAILABLE STAINLESS STEEL TOP



BASIC BENCH WITH 1 1/2" STAINLESS SQUARE EDGE

W" x D"	Model
48 x 30	SC242261
60 x 30	SC242262
72 x 30	SC242263

48"W x 24"D BENCH RETURN

Model	Top
SC249404	Maple
SC249405	Plastic
SC249406	Shop Top
SC249407	ESD

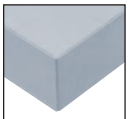

1 5/8" PLASTIC
SQUARE EDGE

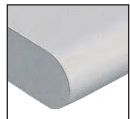

1 5/8" PLASTIC
SAFETY EDGE



1 3/4" MAPLE
SQUARE EDGE



1 3/4" MAPLE
SAFETY EDGE

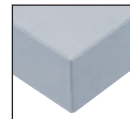

1 1/4" ESD
SQUARE EDGE

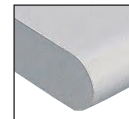

1 1/4" ESD
SAFETY EDGE

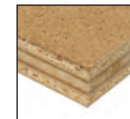

1 1/2" SHOP TOP
SQUARE EDGE



1 3/4" SHOP TOP
SAFETY EDGE

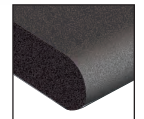

1" PHENOLIC
SAFETY EDGE

BASIC BENCH WITH BENCH TOP

W" x D"	PLASTIC SQUARE EDGE		MAPLE SQUARE EDGE		ESD SQUARE EDGE		SHOP TOP SQUARE EDGE	SHOP TOP SAFETY EDGE	PHENOLIC RESIN SAFETY EDGE
	Model	Model	Model	Model	Model	Model	Model	Model	Model
48 x 30	SC606974	SC606998	SC606982	SC607004	SC606990	SC607263	SC253835	SC253842	—
48 x 36	SC606975	SC606999	SC606983	SC607005	SC606991	SC607264	—	—	—
60 x 24	SC249185	—	SC249187	—	—	—	—	—	—
60 x 30	SC606976	SC607000	SC606984	SC607006	SC606992	SC607265	SC253836	SC253843	SC237383
60 x 36	SC606977	SC607001	SC606985	SC607007	SC606993	SC607266	SC253837	—	SC237384
72 x 24	SC249186	—	SC249188	—	—	—	—	—	—
72 x 30	SC606978	SC607002	SC606986	SC607008	SC606994	SC607267	SC253838	SC253844	SC237385
72 x 36	SC606979	SC607003	SC606987	SC607262	SC606995	SC607268	SC253839	SC253845	SC237386
96 x 30*	SC606980	—	SC606988	—	SC606996	—	SC253840	—	—
96 x 36*	SC606981	—	SC606989	—	SC606997	—	SC253841	—	—

*3500 lb. capacity

PRE-WIRED POWER APRON: Includes three duplex outlets, circuit breaker switch, 15 amps/115 volts, 13' cord. Add "B" to Model.

PRODUCTION BENCH

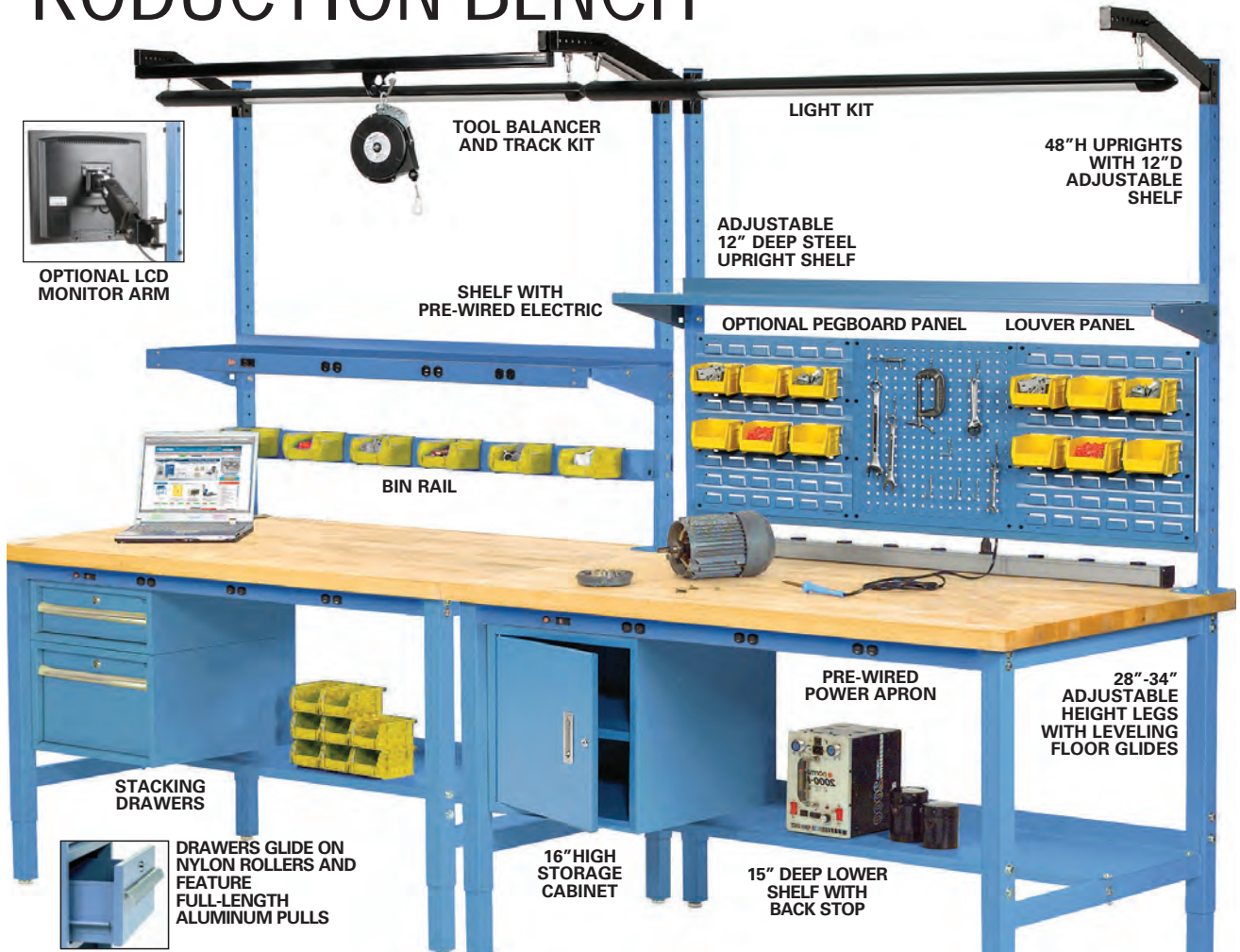

OPTIONAL LCD MONITOR ARM

TOOL BALANCER AND TRACK KIT

LIGHT KIT

48" H UPRIGHTS WITH 12" D ADJUSTABLE SHELF

ADJUSTABLE 12" DEEP STEEL UPRIGHT SHELF

SHELF WITH PRE-WIRED ELECTRIC

OPTIONAL PEGBOARD PANEL

LOUVER PANEL

BIN RAIL

PRE-WIRED POWER APRON

28"-34" ADJUSTABLE HEIGHT LEGS WITH LEVELING FLOOR GLIDES

STACKING DRAWERS



DRAWERS GLIDE ON NYLON ROLLERS AND FEATURE FULL-LENGTH ALUMINUM PULLS

16" HIGH STORAGE CABINET

15" DEEP LOWER SHELF WITH BACK STOP

HEAVY DUTY PRODUCTION BENCH ACCESSORIES

48" H UPRIGHT WITH 12" ADJUSTABLE SHELF

Model	Bench W"
SC432209	48
SC432210	60
SC432211	72
SC432212	96

UPRIGHT SHELF-12" D

Model	Bench W"
SC606945	48
SC606946	60
SC606947	72
SC606948	96

(Requires Upright Kit)

BIN RAIL

Model	Bench W"
SC606941	48
SC606942	60
SC606943	72
SC606944	96

(Requires Upright Kit)
(See Page 5 for Bins)

SHELF WITH PRE-WIRED ELECTRIC

Three duplex outlets, circuit breaker, switch and 12 ft. power cord. 15 amps-115 volts.

Model	Bench W"
SC249294	48
SC249295	60
SC249296	72
SC249297TN	96
SC249297BL	96

(Requires Upright Kit)

LIGHT KIT (Includes bulbs)

Model	Bench W"
SC607269A	48
SC607270A	60
SC607271A	72
SC607272A*	96

*96" Light Kit uses two 48" light fixtures
(Requires Upright Kit)

30 PIECE PEG HOOK SET

Model
SC606968B

STEEL PEGBOARD PANEL

Model	W" x H"
SC249286*	18 x 19
SC249287*	36 x 19

LOUVER PANEL

Model	W" x H"
SC249288*	18 x 19
SC249289*	36 x 19

PANEL MOUNTING KIT

Model	Bench W"
SC249291	48
SC249292	60
SC249293†	72

*Requires Upright & Mounting Kit
†Holds one 36" and one 18" panel, does not hold two 36" panels

ELECTRIC STRIP-48" L

Model	Outlets
SC190322B	8
SC190323B	16

LOWER SHELF-15" D

Model	Bench W"
SC606949	48
SC606949TN	48
SC606950	60
SC606950TN	60
SC606951	72
SC606952	96

STORAGE CABINET with removable center shelf, recessed handle and cylinder lock 17 1/4" W X 20" D X 16" H

Model SC249385*

*Fits 24", 30" and 36" depth

LCD MONITOR ARM

Model	SC249624

(Requires Upright Kit)

PRE-WIRED POWER APRON: Includes three duplex outlets, circuit breaker, switch 15 amps/115 volts, 13' cord.

Note: Tool balancer track kit, upright shelf, light kit, bin rail & LCD monitor arm requires upright kit.

STACKING DRAWER

Model	H"
17 1/4" W x 20" D	
SC249374*	6
SC249375*	12

*Fits 24", 30" and 36" Bench

TOOL BALANCER-8 foot cable

Model	Cap.
SC249459	10 lbs.

(Requires Tool Balancer Track Kit)

TOOL BALANCER TRACK KIT

Includes tool track & 2 rolling hook trolleys.

Model	Bench W"
SC249497	60
SC249498	72

(Track Kit Requires Upright Kit)

CUSTOMER PRIORITY NO.

INDEX
p. ii

Over 1,000,000 Products Online @ chproducts.com

Workbenches



Shop Desks,
Security
Benches & More
Pgs. 148-163

Plastic Service Carts



Plastic
Flat Shelf,
Tray Top, &
Security Carts
Pgs. 74-75

**Mobile Rack
with Bins**



Bins, Totes & Containers
Pgs. 2-10



Cylinder Storage Cabinet



Specialty Storage
Cabinets
Pgs. 52-54

**Office
Seating**



Huge
Selection Of
Seating
Pgs. 101-145



Industrial Blower Fans

Check Out Our HVAC/R
& Fans Section
Pgs. 93-97



ELECTRICAL & BULBS	FASTENERS & HARDWARE	FOODSERVICE & APPLIANCE	FURNITURE & OFFICE
HVAC/R & FANS	JANITORIAL & MAINTENANCE	MATERIAL HANDLING	MEDICAL & LAB EQUIPMENT
METAL WORKING	MOTORS & POWER TRANSMISSIONS		OFFICE & SCHOOL SUPPLIES
OUTDOOR & GROUNDS MAINTENANCE		PACKAGING & SUPPLIES	PLUMBING & PUMPS
PNEUMATICS & HYDRAULICS		PROMOTIONAL PRODUCTS	RAW MATERIAL & BUILDING SUPPLIES
SAFETY & PPE	STORAGE & SHELVING	TOOLS & INSTRUMENTS	VEHICLE MAINTENANCE