



TOOLS CATALOG

"Quality The First Time"

WHO WE ARE

GOEBEL FASTENERS INC. is a subsidiary of GOEBEL GmbH, which has been the leading corporation in Europe for specialty fastener technology since 1979.

We founded our U.S. headquarters in 2016, located in Houston, TX with one goal in mind. To provide unparalleled high quality products and first class service to each and every customer. Our products demonstrate innovation that not only exceeds the norm, but enhances quality, reduces maintenance, and increases application efficiency.



Limited Warranty

Tooling Warranty: Goebel Fasteners, Inc. warrants that tooling and other items (excluding fasteners, and hereinafter referred as "other items") manufactured by Goebel Fasteners, Inc. shall be free from defects in workmanship and materials for a period of twelve (12) months from the date of original purchase.

THERE ARE NO WARRANTIES WHICH EXTEND BEYOND THE DESCRIPTION ON THE FACE HEREOF. GOEBEL FASTENERS, INC. MAKES NO OTHER WARRANTIES AND EXPRESSLY DISCLAIMS ANY OTHER WARRANTIES, INCLUDING IMPLIED WARRANTIES AS TO MERCHANTABILITY OR AS TO THE FITNESS OF THE TOOLING, OTHER ITEMS, NONSTANDARD OR CUSTOM MANUFACTURED PRODUCTS FOR ANY PARTICULAR PURPOSE AND HUCK SHALL NOT BE LIABLE OR ANY LOSS OR DAMAGE, DIRECTLY OR INDIRECTLY, ARISING FROM THE USE OF SUCH TOOLING, OTHER ITEMS, NONSTANDARD OR CUSTOM MANUFACTURED PRODUCTS OR BREACH OF WARRANTY OR FOR ANY CLAIM FOR INCIDENTAL OR CONSEQUENTIAL DAMAGES.

Goebel Fasteners, Inc.'s sole liability and Buyer's exclusive remedy for any breach of warranty shall be limited, at Goebel Fasteners, Inc.'s option, to replacement or repair, at FOB Goebel Fasteners, Inc.'s plant, of Goebel Fasteners, Inc. manufactured tooling, other items, nonstandard or custom products found to be defective in specifications, workmanship and materials not otherwise the direct or indirect cause of Buyer supplied molds, material, tooling or fixtures. Buyer shall give Goebel Fasteners, Inc. written notice of claims for defects within the twelve (12) months warranty period for tooling, other items, nonstandard or custom products described above and Goebel Fasteners, Inc. shall inspect products for which such claim is made.

Tooling, Part(s) and Other Items not manufactured by Goebel Fasteners, Inc. GOEBEL FASTENERS, INC. MAKES NO WARRANTY WITH RESPECT TO THE TOOLING, PART(S) OR OTHER ITEMS MANUFACTURED BY THIRD PARTIES. GOEBEL FASTENERS, INC. EXPRESSLY DISCLAIMS ANY WARRANTY EXPRESSED OR IMPLIED, AS TO THE CONDITION, DESIGN, OPERATION, MERCHANTABILITY OR FITNESS FOR USE OF ANY TOOL, PART(S), OR OTHER ITEMS THEREOF NOT MANUFACTURED BY GOEBEL FASTENERS, INC. GOEBEL FASTENERS, INC. SHALL NOT BE LIABLE FOR ANY LOSS OR DAMAGE, DIRECTLY OR INDIRECTLY, ARISING FROM THE USE OF SUCH TOOLING, PART(S) OR OTHER ITEMS OR BREACH OF WARRANTY OR FOR ANY CLAIM FOR INCIDENTAL OR CONSEQUENTIAL DAMAGES.

The only warranties made with respect to such tool, part(s) or other items thereof are those made by the manufacturer thereof and Goebel Fasteners, Inc. agrees to cooperate with Buyer in enforcing such warranties when such action is necessary. Goebel Fasteners, Inc. shall not be liable for any loss or damage resulting from delays or nonfulfillment of orders owing to strikes, fires, accidents, transportation companies or for any reason or reasons beyond the control of the Goebel Fasteners, Inc. or its suppliers.



TABLE OF CONTENTS

TOOL SELECTION GUIDE	4 - 6
HAND TOOLS FOR BLIND RIVETS	
GO-2	7
GO-3	7
GO-55	8
GO-360	8
GO-40	9
GO-25-SN	9
GO-39	10
GO-12-R	11
HAND TOOLS FOR BLIND RIVET NUTS	
GO-35	12
GO-35-UN	12
GO-510	13
GO-510-UN	13
GO-520	14
GO-520-UN	14
GO-12-N	15
HAND TOOLS FOR PIN & COLLAR	
GO-12-P	16
PNEUMATIC TOOLS FOR BLIND RIVETS	
AIRPOWER 1	17
AIRPOWER 2	17
AIRPOWER 3	18
PNEUMATIC TOOLS FOR BLIND RIVET NUTS	
AIRPOWER 4	18
CORDLESS TOOLS FOR BLIND RIVETS	
GO-100	19
GO-100+	20
GO-200	21
CORDLESS TOOLS FOR BLIND RIVET NUTS	
GO-300-UN	22
CORDLESS TOOLS FOR PIN & COLLAR	
GO-400	23



TOOL SELECTION GUIDE



			BLIND RIVETS					
			STANDARD BLIND RIVETS, MULTI-GRIP, TRI-FOLDING, SPECIAL BLIND RIVETS					
			3/32" 2.4 mm	1/8" 3.2 mm	5/32" 4.0 mm	3/16" 4.8 mm	1/4" 6.4 mm	9/32" 7.5 mm
HAND	GO-2							
	GO-3							
	GO-55					AS		
	GO-360				AS	AS		
	GO-40							
	GO-25-SN							
	GO-39							
	GO-12-R							
PNEUMATIC HYDRAULIC	AIRPOWER 1							
	AIRPOWER 2							
	AIRPOWER 3							
CORDLESS	GO-100							
	GO-100+					*	*	*
	GO-200							

A: ALUMINUM / COPPER
 S: STEEL
 I: INOX

BLUE FIELD: RECOMMENDED WORKING RANGE (ASI)
 EXCEPTIONS ARE INDICATED BY RELEVANT LETTERS
 * = SPECIAL NOSE PIECE REQUIRED FOR SETTING

Subject to modifications



TOOL SELECTION GUIDE

			SEMI-STRUCTURAL BLIND RIVETS							
			GO-BULB II				GO-INOX II			
			1/8" 3.2 mm	5/32" 4.0 mm	3/16" 4.8 mm	.236" 6.0 mm	1/8" 3.2 mm	5/32" 4.0 mm	3/16" 4.8 mm	
HAND	GO-40									
	GO-25-SN									
	GO-39									
PNEUMATIC HYDRAULIC	AIRPOWER 1									
	AIRPOWER 2									
	AIRPOWER 3									
CORDLESS	GO-100									
	GO-200									

			STRUCTURAL BLIND RIVETS						
			GO-LOCK		M-LOCK		H-LOCK	PREMIUM	
			3/16" 4.8 mm	1/4" 6.4 mm	3/16" 4.8 mm	1/4" 6.4 mm	1/4" 6.4 mm	3/16" 4.8 mm	1/4" 6.4 mm
HAND	GO-40			AS	*	* AS	AS		AS
	GO-25-N			AS	*	* AS	AS		AS
	GO-39				*	*			
PNEUMATIC HYDRAULIC	AIRPOWER 1		A					A	
	AIRPOWER 2			A					A
	AIRPOWER 3				*	*			
CORDLESS	GO-100			A					A
	GO-200				*	*			

A: ALUMINUM / COPPER
 S: STEEL
 I: INOX

BLUE FIELD: RECOMMENDED WORKING RANGE (ASI)
 EXCEPTIONS ARE INDICATED BY RELEVANT LETTERS
 * = SPECIAL NOSE PIECE REQUIRED FOR SETTING



TOOL SELECTION GUIDE

			BLIND RIVET NUTS							
			M3	M4	M5	M6	M8	M10	M12	
HAND	GO-35					AS				
	GO-510								AS	
	GO-520								AS	
	GO-12-N									
			6 - 32	10 - 24	10 - 32	1/4" - 20	5/16" - 18	3/8" - 16	1/2" - 13	
	GO-35-UN					AS				
	GO-510-UN								AS	
	GO-520-UN								AS	
PNEUM. HYDR.			M3	M4	M5	M6	M8	M10	M12	
	AIRPOWER 4								AS	
			6 - 32	10 - 24	10 - 32	1/4" - 20	5/16" - 18	3/8" - 16	1/2" - 13	
CORDLESS			M3	M4	M5	M6	M8	M10	M12	
	GO-300								AS	
			6 - 32	10 - 24	10 - 32	1/4" - 20	5/16" - 18	3/8" - 16	1/2" - 13	
								AS		

			PIN & COLLAR			
			3/16" 4.8 mm	1/4" 6.4 mm	5/16" 8.0 mm	3/8" 9.6 mm
HAND	GO-12-P					
CORDLESS	GO-400					

A: ALUMINUM / COPPER
 S: STEEL
 I: INOX

BLUE FIELD: RECOMMENDED WORKING RANGE (ASI)
 EXCEPTIONS ARE INDICATED BY RELEVANT LETTERS
 * = SPECIAL NOSE PIECE REQUIRED FOR SETTING

GO-2 - HAND RIVET TOOL

AUTOMATIC EJECTION OF RETAINED MANDREL AFTER SETTING BLIND RIVET

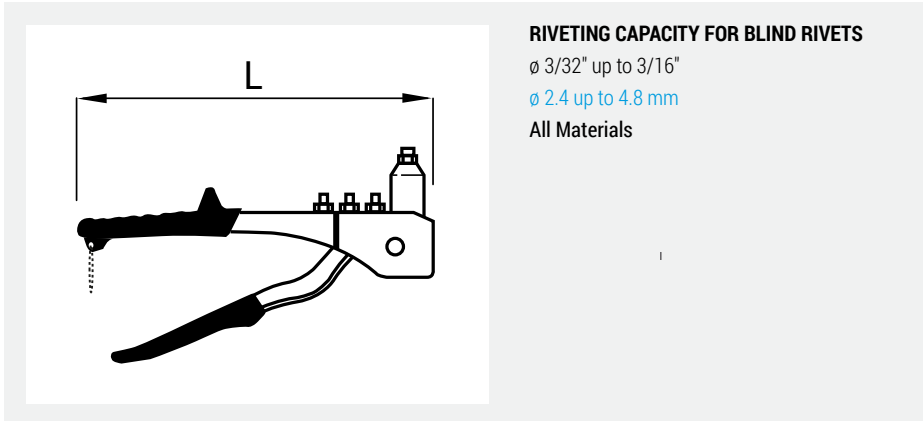

RIVETING CAPACITY FOR BLIND RIVETS

ø 3/32" up to 3/16"

ø 2.4 up to 4.8 mm

All Materials

WEIGHT	1.15 lbs	0.52 kg
LENGTH	9 - 1/2"	243 mm
EQUIPMENT	INCLUDES FOUR MOUNTED NOSEPIECES (3/32", 1/8", 5/32", 3/16") AND A SERVICE WRENCH	2.4, 3.2, 4.0, 4.8 mm
MATERIAL	HIGH STRENGTH ALUMINUM BODY WITH FORGED STEEL UPPER HANDLE	
ITEM CODE	22900 00020	

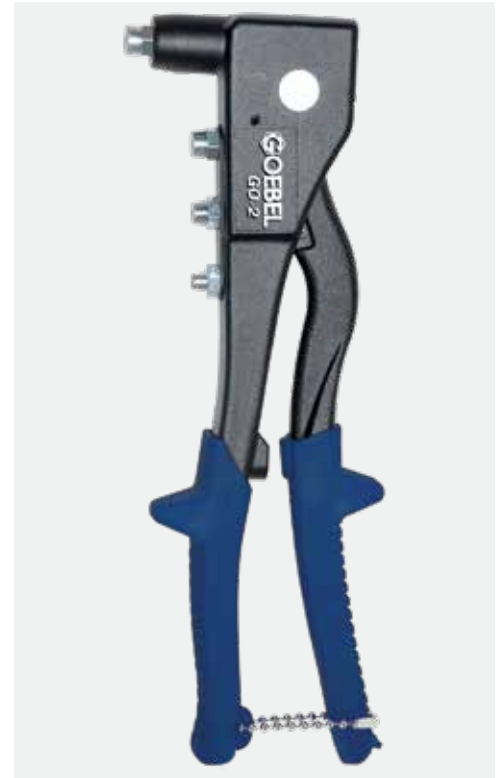

GO-3 - HAND RIVET TOOL

AUTOMATIC EJECTION OF RETAINED MANDREL AFTER SETTING BLIND RIVET

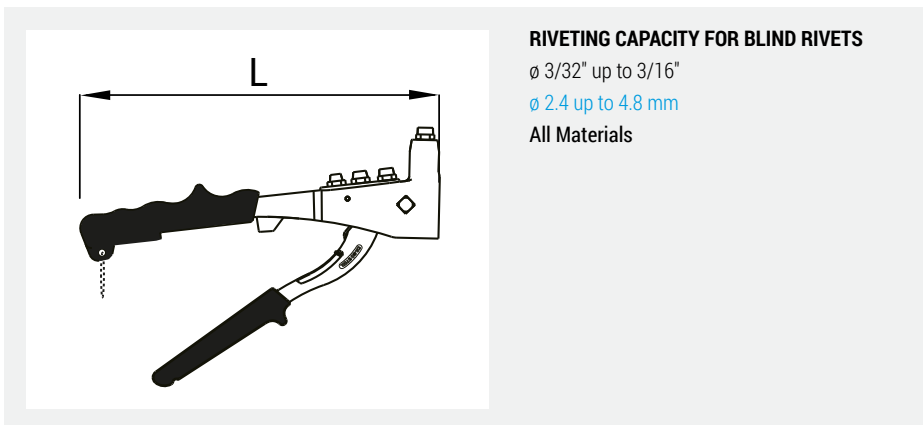

RIVETING CAPACITY FOR BLIND RIVETS

ø 3/32" up to 3/16"

ø 2.4 up to 4.8 mm

All Materials

WEIGHT	1.32 lbs	0.60 kg
LENGTH	10 - 1/4"	260 mm
EQUIPMENT	INCLUDES FOUR MOUNTED NOSEPIECES (3/32", 1/8", 5/32", 3/16") AND A SERVICE WRENCH	2.4, 3.2, 4.0, 4.8 mm
MATERIAL	HIGH STRENGTH ALUMINUM BODY WITH FORGED CR-MO STEEL UPPER HANDLE	
ITEM CODE	22900 00030	





GO-55 - HAND RIVET TOOL

AUTO HOLD DESIGN KEEPS MANDREL GRIPPED IN ANY POSITION

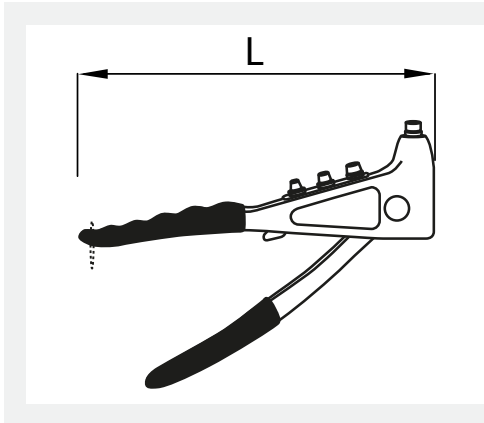

RIVETING CAPACITY FOR BLIND RIVETS

Ø 3/32" up to 5/32"

Ø 2.4 up to 4.0 mm

All Materials

Ø 3/16"

Ø 4.8 mm

Aluminum / Steel



WEIGHT	1.17 lbs	0.53 kg
LENGTH	9 - 1/4"	235 mm
EQUIPMENT	INCLUDES FOUR MOUNTED NOSEPIECES (3/32", 1/8", 5/32", 3/16") AND A SERVICE WRENCH	2.4, 3.2, 4.0, 4.8 mm
MATERIAL	HIGH STRENGTH ALUMINUM BODY WITH FORGED STEEL UPPER HANDLE	
ITEM CODE	22900 00550	

GO-360 - HAND RIVET TOOL

360° SWIVEL RATCHET HEAD - AUTOMATIC EJECTION OF RETAINED MANDREL AFTER SETTING BLIND RIVET

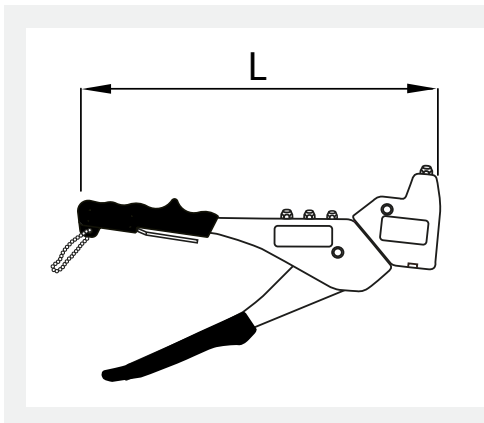

RIVETING CAPACITY FOR BLIND RIVETS

Ø 3/32" up to 1/18"

Ø 2.4 up to 3.2 mm

All Materials

Ø 5/32"

Ø 4.0 mm

Aluminum / Steel

Ø 3/16"

Ø 4.8 mm

Aluminum



WEIGHT	1.57 lbs	0.71 kg
LENGTH	11 - 7/16"	290 mm
EQUIPMENT	INCLUDES FOUR MOUNTED NOSEPIECES (3/32", 1/8", 5/32", 3/16") AND A SERVICE WRENCH	2.4, 3.2, 4.0, 4.8 mm
MATERIAL	HIGH STRENGTH ALUMINUM HEAD AND BODY WITH HEAVY-DUTY STEEL UPPER HANDLE	
ITEM CODE	22900 03600	

Subject to modifications

GO-40 - HEAVY DUTY LEVER TYPE HAND RIVET TOOL

HIGH LEVERAGE DESIGN TO REDUCE GRIP FORCE PRESSURE - INCLUDES SPENT MANDREL CONTAINER

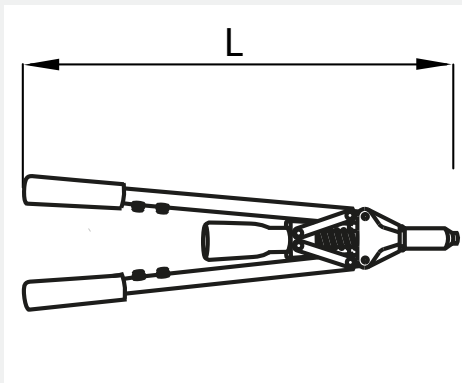

RIVETING CAPACITY FOR BLIND RIVETS
 ϕ 1/8" up to 1/4"
 ϕ 3.2 up to 6.4 mm
 All Materials

FOR STRUCTURAL BLIND RIVETS
 ϕ 3/16"
 ϕ 4.8 mm
 All Materials
 ϕ .236", 1/4"
 ϕ 6.0, 6.4 mm
 Aluminum / Steel

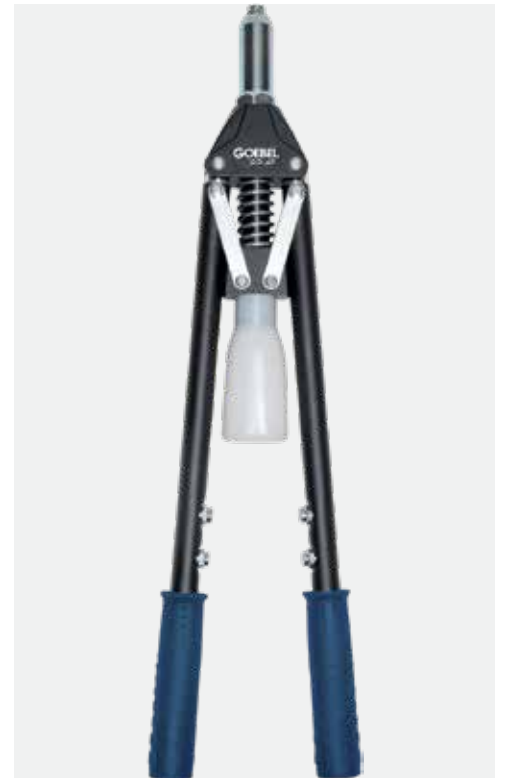

WEIGHT	3.77 lbs	1.71 kg
LENGTH	21"	533 mm
EQUIPMENT	INCLUDES FIVE STANDARD NOSEPIECES (1/8", 5/32", 3/16", .236", 1/4") AND SERVICE WRENCH	3.2, 4.0, 4.8, 6.0, 6.4 mm
MATERIAL	ROBUST STRUCTURE WITH HIGH STRENGTH ALUMINUM BODY & LARGE STEEL HANDLES	
ITEM CODE	22900 00400	

GO-25-SN - HEAVY DUTY LAZY TONG RIVET TOOL

4-JOINTED SLIDE BLOCK BEARING DESIGN REDUCES MANUAL EXERTION

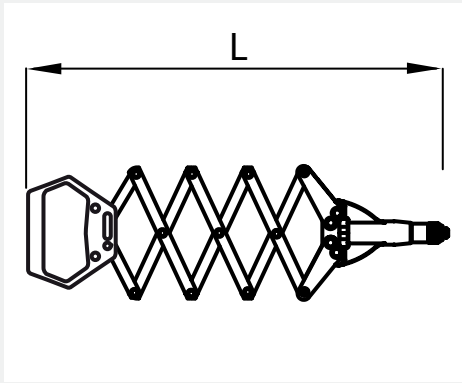

RIVETING CAPACITY FOR BLIND RIVETS
 ϕ 1/8" up to 1/4"
 ϕ 3.2 up to 6.4 mm
 All Materials

FOR STRUCTURAL BLIND RIVETS
 ϕ 3/16"
 ϕ 4.8 mm
 All Materials
 ϕ .236", 1/4"
 ϕ 6.0, 6.4 mm
 Aluminum / Steel



WEIGHT	4.28 lbs	1.94 kg
LENGTH	(CLOSED) 12 - 5/8" / (OPENED) 32 - 1/4"	320 / 820 mm
EQUIPMENT	INCLUDES FIVE STANDARD NOSEPIECES (1/8", 5/32", 3/16", .236", 1/4")	3.2, 4.0, 4.8, 6.0, 6.4 mm
MATERIAL	HIGH STRENGTH ALUMINUM BODY AND HANDLE	
ITEM CODE	22900 00250	



GO-39 - SUPER HEAVY DUTY HAND RIVET TOOL

HIGH LEVERAGE 3-GEAR SYSTEM DESIGN SIGNIFICANTLY REDUCES GRIP FORCE PRESSURE

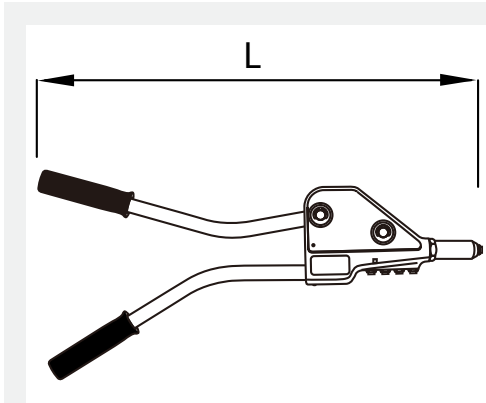

RIVETING CAPACITY FOR BLIND RIVETS

Ø 5/32" up to 1/4"

Ø 4.0 up to 6.4 mm

All Materials

FOR STRUCTURAL BLIND RIVETS

Ø 3/16" up to 1/4"

Ø 4.8 up to 6.4 mm

All Materials



WEIGHT	3.92 lbs	1.78 kg
LENGTH	22"	560 mm
EQUIPMENT	INCLUDES THREE STANDARD NOSEPIECES (5/32", 3/16", 1/4") PLUS TWO MONOBOLT® NOSEPIECES (3/16", 1/4") AND A SERVICE WRENCH	4.0, 4.8, 6.4 mm 4.8, 6.4 mm
MATERIAL	HIGH STRENGTH 1-PIECE ALUMINUM BODY & LARGE STEEL HANDLES	
ITEM CODE	22900 00390	

GO-12-R SET - HAND RATCHET TOOL FOR BLIND RIVETS

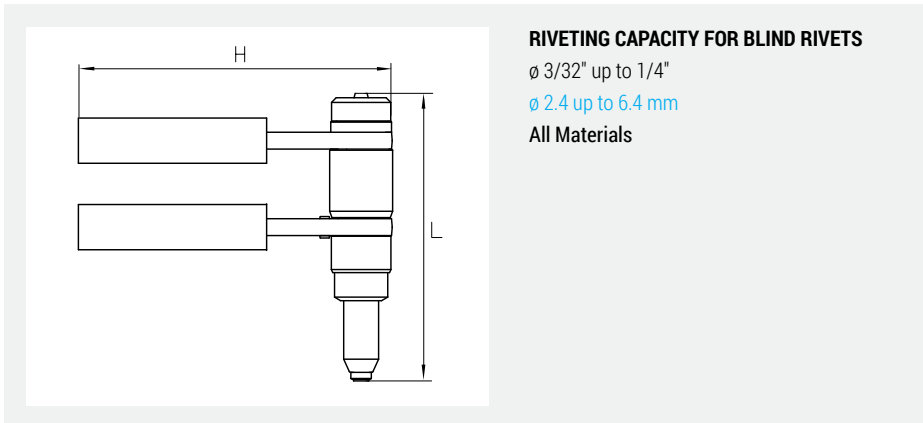

WEIGHT	2.32 lbs	1.05 kg
L x H	7.28" x 8.15"	185 x 207 mm
EQUIPMENT	INCLUDES FIVE STANDARD NOSEPIECES (1/8", 5/32", 3/16", .236", 1/4") AND JAWS	3.0/3.2, 4.0, 4.8/5.0, 6.0, 6.4 mm
MATERIAL	FORGED STEEL	
ITEM CODE	22450 00200	



OPTIONAL PARTS

NOSE PIECES	3/32"	2.4 mm
--------------------	-------	--------



GO-35 - HAND RIVET NUT TOOL

FEATURES QUICK CHANGE THREADED MANDRELS & SINGLE STROKE ADJUSTMENT FUNCTION

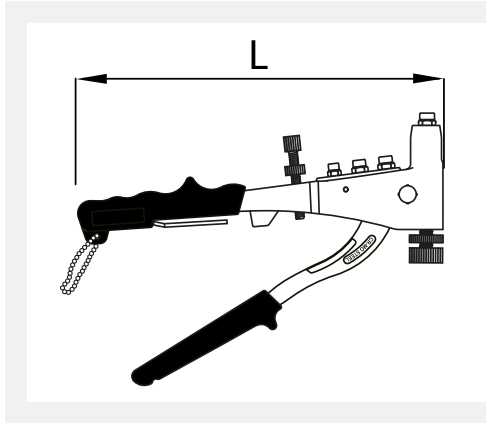

RIVETING CAPACITY FOR BLIND RIVET NUTS

M3 - M5
All Materials
M6
Aluminum / Steel



WEIGHT	1.50 lbs	0.68 kg
LENGTH	10 - 1/4"	260 mm
EQUIPMENT	INCLUDES FOUR THREADED MANDRELS (M3 - M6) AND A SERVICE WRENCH	
MATERIAL	HIGH STRENGTH ALUMINUM BODY WITH FORGED CR-MO STEEL ALLOY UPPER HANDLE	
ITEM CODE	22900 00350	

GO-35-UN - HAND RIVET NUT TOOL

FEATURES QUICK CHANGE THREADED MANDRELS & SINGLE STROKE ADJUSTMENT FUNCTION

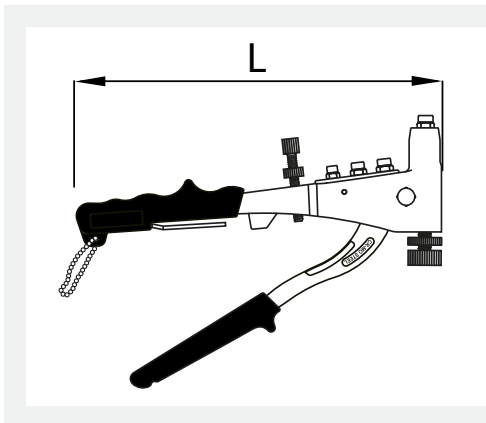

RIVETING CAPACITY FOR BLIND RIVET NUTS

6 - 32 ~ 10 - 24, 10 - 32
All Materials
1/4" - 20
Aluminum / Steel



WEIGHT	1.50 lbs	0.68 kg
LENGTH	10 - 1/4"	260 mm
EQUIPMENT	INCLUDES FIVE THREADED MANDRELS (6 - 32 ~ 1/4" - 20, 10 - 32) AND A SERVICE WRENCH	
MATERIAL	HIGH STRENGTH ALUMINUM BODY WITH FORGED CR-MO STEEL ALLOY UPPER HANDLE	
ITEM CODE	22900 00351	

Subject to modifications

GO-510 - HEAVY DUTY HAND RIVET NUT TOOL

HIGH LEVERAGE DESIGN REDUCES GRIP FORCE PRESSURE & INCREASES RIVETING POWER



RIVETING CAPACITY FOR BLIND RIVET NUTS
 M5 - M10
 All Materials
 M12
 Aluminum / Steel
DETACHABLE & EXCHANGEABLE QUICK-DRILL UNIT



WEIGHT	4.61 lbs	2.09 kg
LENGTH	20 - 7/8"	530 mm
ABS CASE	23 - 1/4" x 10 - 5/8" x 2 - 3/8"	590 x 270 x 60 mm
EQUIPMENT	INCLUDES FIVE THREADED MANDRELS (M5 - M12) PLUS FIVE NOSEPIECES (M5 - M12) AND A SERVICE WRENCH	
MATERIAL	HIGH STRENGTH ALUMINUM BODY & LARGE STEEL HANDLES	
ITEM CODE	22900 05100	

GO-510-UN - HEAVY DUTY HAND RIVET NUT TOOL

HIGH LEVERAGE DESIGN REDUCES GRIP FORCE PRESSURE & INCREASES RIVETING POWER

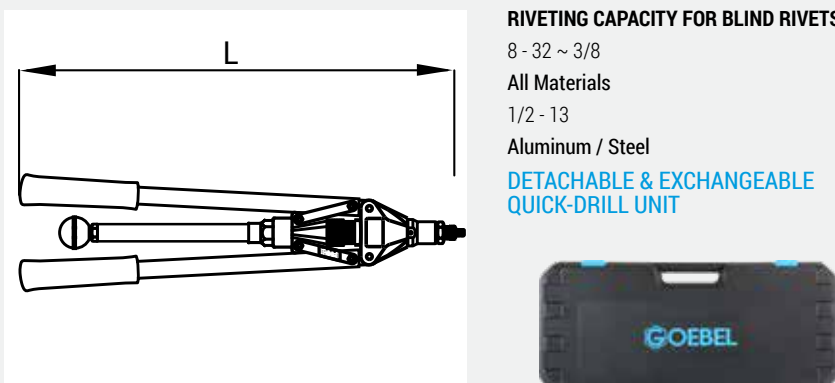

RIVETING CAPACITY FOR BLIND RIVETS NUTS
 8 - 32 ~ 3/8
 All Materials
 1/2 - 13
 Aluminum / Steel
DETACHABLE & EXCHANGEABLE QUICK-DRILL UNIT



WEIGHT	4.61 lbs	2.09 kg
LENGTH	20 - 7/8"	530 mm
ABS CASE	23 - 1/4" x 10 - 5/8" x 2 - 3/8"	590 x 270 x 60 mm
EQUIPMENT	INCLUDES SIX THREADED MANDRELS (10 - 24 ~ 1/2 - 13, 10 - 32) PLUS FIVE NOSEPIECES (#10, 1/4", 5/16", 3/8", 1/2") AND A SERVICE WRENCH	
MATERIAL	HIGH STRENGTH ALUMINUM BODY & LARGE STEEL HANDLES	
ITEM CODE	22900 05101	



GO-520 - HEAVY DUTY HAND RIVET NUT TOOL

HIGH LEVERAGE DESIGN REDUCES GRIP FORCE PRESSURE & INCREASES RIVETING POWER

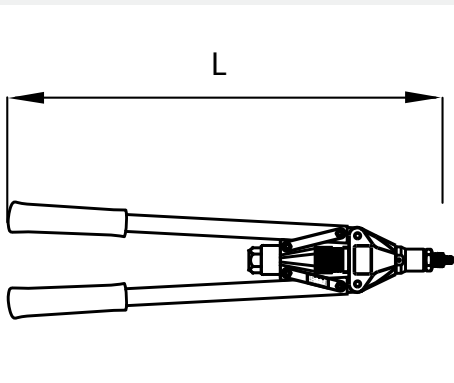

RIVETING CAPACITY FOR BLIND RIVET NUTS
M5 - M10
All Materials
M12
Aluminum / Steel
DETACHABLE & EXCHANGEABLE EASY-TURN UNIT



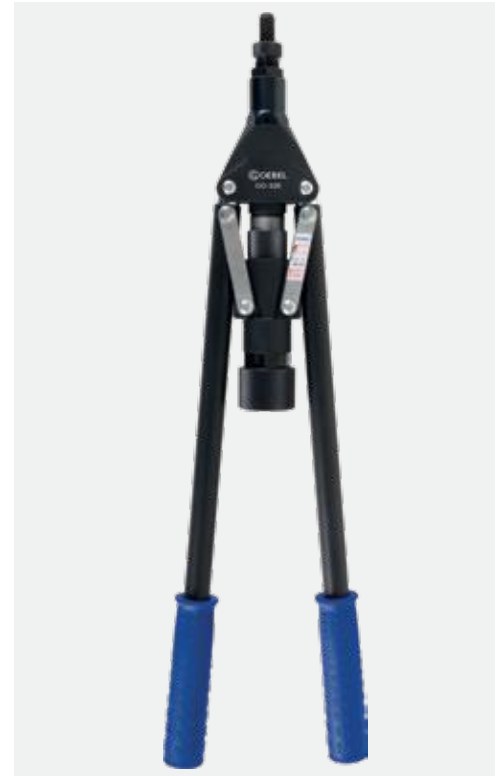



WEIGHT	4.61 lbs	2.09 kg
LENGTH	20 - 7/8"	530 mm
ABS CASE	23 - 1/4" x 10 - 5/8" x 2 - 3/8"	590 x 270 x 60 mm
EQUIPMENT	INCLUDES FIVE THREADED MANDRELS (M5 - M12) PLUS FIVE NOSEPIECES (M5 - M12) AND A SERVICE WRENCH	
MATERIAL	HIGH STRENGTH ALUMINUM BODY & LARGE STEEL HANDLES	
ITEM CODE	22900 05200	

GO-520-UN - HEAVY DUTY HAND RIVET NUT TOOL

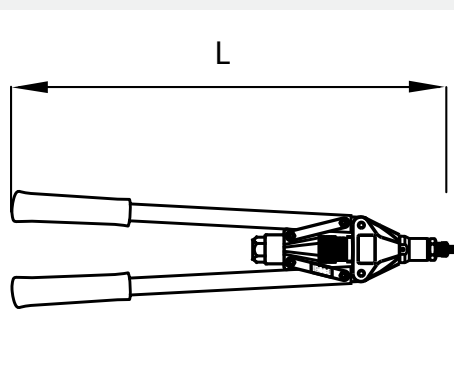
HIGH LEVERAGE DESIGN REDUCES GRIP FORCE PRESSURE & INCREASES RIVETING POWER



RIVETING CAPACITY FOR BLIND RIVETS NUTS
8 - 32 ~ 3/8
All Materials
1/2 - 13
Aluminum / Steel
DETACHABLE & EXCHANGEABLE EASY-TURN UNIT





WEIGHT	4.61 lbs	2.09 kg
LENGTH	20 - 7/8"	530 mm
ABS CASE	23 - 1/4" x 10 - 5/8" x 2 - 3/8"	590 x 270 x 60 mm
EQUIPMENT	INCLUDES SIX THREADED MANDRELS (10 - 24 ~ 1/2 - 13, 10 - 32) PLUS FIVE NOSEPIECES (#10, 1/4", 5/16", 3/8", 1/2") AND A SERVICE WRENCH	
MATERIAL	HIGH STRENGTH ALUMINUM BODY & LARGE STEEL HANDLES	
ITEM CODE	22900 05201	

Subject to modifications

GO-12-N SET - HAND RATCHET TOOL FOR BLIND RIVET NUTS

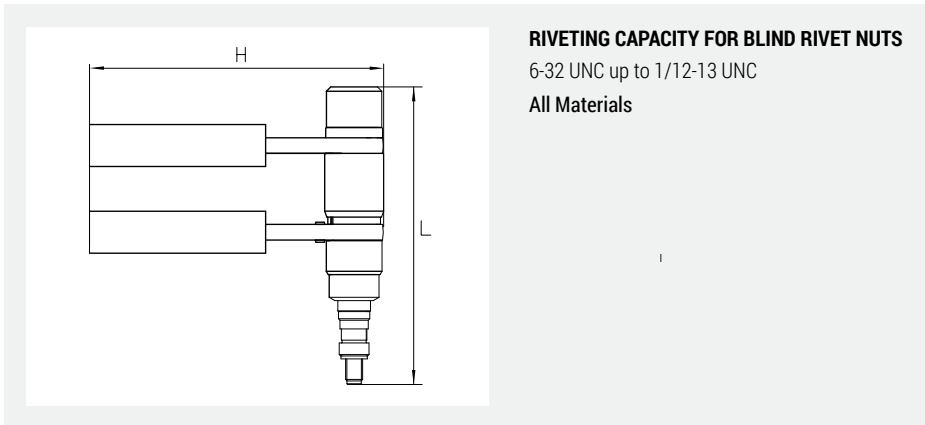

RIVETING CAPACITY FOR BLIND RIVET NUTS
 6-32 UNC up to 1/12-13 UNC
 All Materials



WEIGHT	2.51 lbs	1.14 kg
L x H	8.27" x 8.15"	210 x 207 mm
EQUIPMENT	INCLUDES MANDRELS AND ANVILS (10-24 UNC, 10-32 UNF, 1/4-20 UNC, 5/16-18 UNC, 3/8-16 UNC, 1/2-13 UNC)	
MATERIAL	FORGED STEEL	
ITEM CODE	22450 01100	



OPTIONAL PARTS

MANDRELS AND ANVILS	6-32 UNC / 8-32 UNC	M5 up to M12
THREADED SOCKETS		M5 up to M8



GO-12-P SET - HAND RATCHET TOOL FOR PIN & COLLAR

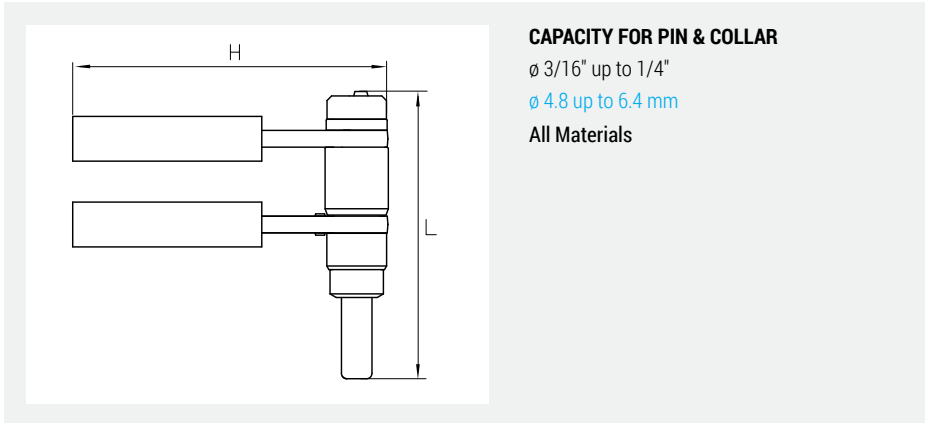

WEIGHT	2.43 lbs	1.1 kg
L x H	7.32" x 8.15"	186 x 207 mm
EQUIPMENT	INCLUDES NOSEPIECE FOR 1/4" (ACCORDING TO "C6L" - STANDARD)	6.4 mm
MATERIAL	FORGED STEEL	
ITEM CODE	22450 00300	



OPTIONAL PARTS

NOSE PIECES (*ACCORDING "C6L"-STANDARD)	3/16"	4.8 mm
JAWS HELL	3/16"	4.8 mm
RUBBER 3-JAWS	3/16"	4.8 mm

AIRPOWER 1 - PNEUMATIC/HYDRAULIC BLIND RIVET SETTING TOOL

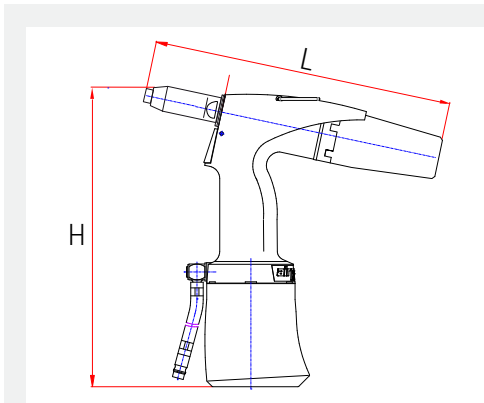

RIVETING CAPACITY FOR BLIND RIVETS

ø 3/32" up to 3/16"

ø 2.4 up to 4.8 mm

All Materials

WEIGHT	2.76 lbs	1.25 kg
L x H	10.71" x 10.39"	272 x 264 mm
EQUIPMENT	INCLUDES THREE MOUNTED NOSEPIECES (1/8", 5/32", 3/16") AND A SERVICE WRENCH	3.2, 4.0, 4.8 mm
STROKE	0.67"	17 mm
PULLING FORCE	1641 (@ 87 psi)	7.3 kn (@ 6.0 bar)
WORKING AIR PRESSURE	72.5 - 100 psi	5 - 7 bar
MATERIAL		ABS
ITEM CODE		22441 00001



AIRPOWER 2 - PNEUMATIC/HYDRAULIC BLIND RIVET SETTING TOOL

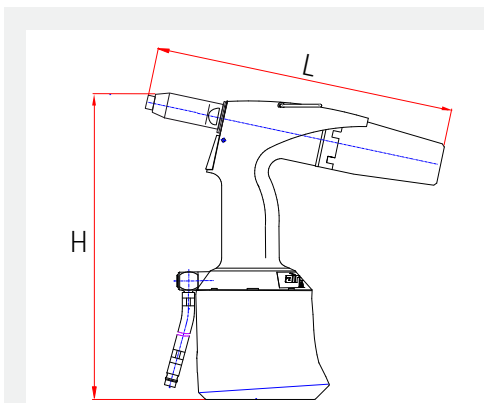

RIVETING CAPACITY FOR BLIND RIVETS NUTS

ø 5/32" up to 1/4"

ø 4.0 up to 6.4 mm

All Materials

WEIGHT	3.64 lbs	1.65 kg
L x H	10.71" x 10.83"	272 x 275 mm
EQUIPMENT	INCLUDES FOUR MOUNTED NOSEPIECES (5/32", 3/16", .236", 1/4") AND A SERVICE WRENCH	4.0, 4.8, 6.0, 6.4 mm
STROKE	0.83"	21 mm
PULLING FORCE	2810 (@ 87 psi)	12.5 kn (@ 6.0 bar)
WORKING AIR PRESSURE	72.5 - 100 psi	5 - 7 bar
MATERIAL		ABS
ITEM CODE		22441 00002





AIRPOWER 3 - PNEUMATIC/HYDRAULIC SETTING TOOL FOR STRUCTURAL BLIND RIVETS

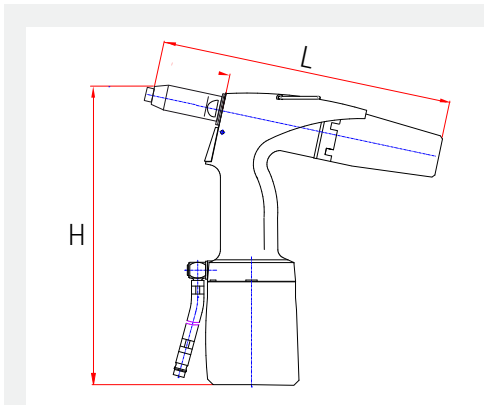

RIVETING CAPACITY FOR BLIND RIVETS

ϕ 3/16" up to 1/4"
 ϕ 4.8 up to 6.4 mm
 All Materials



WEIGHT	4.41 lbs	2.0 kg
L x H	11.10" x 11.58"	282 x 294 mm
EQUIPMENT	INCLUDES TWO MOUNTED NOSEPIECES (3/16", 1/4") AND A SERVICE WRENCH	
STROKE	1.1"	28 mm
PULLING FORCE	3709 (@ 87 psi)	16.5 kn (@ 6.0 bar)
WORKING AIR PRESSURE	72.5 - 100 psi	5 - 7 bar
MATERIAL	ABS	
ITEM CODE	22441 00003	

AIRPOWER 4 - PNEUMATIC/HYDRAULIC SETTING TOOL FOR BLIND RIVET NUTS AND BOLTS

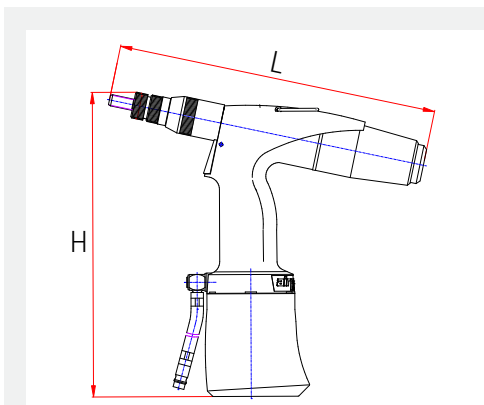

RIVETING CAPACITY FOR BLIND RIVET NUTS

M3 - M10
 All Materials
 M3 - M12
 Aluminum / Steel



WEIGHT	3.53 lbs	1.6 kg
L x H	11.10" x 10.63"	285 x 270 mm
EQUIPMENT	INCLUDES FOUR THREADED MANDRELS (M4 - M8) PLUS THREADED THREE SOCKETS (M5 - M8) AND A SERVICE WRENCH	
STROKE	0.28"	7 mm
PULLING FORCE	4204 (@ 87 psi)	18.7 kn (@ 6.0 bar)
WORKING AIR PRESSURE	72.5 - 100 psi	5 - 7 bar
MATERIAL	ABS	
ITEM CODE	22441 00004	

Subject to modifications



GO-100 - LITHIUM-ION CORDLESS RIVET TOOL

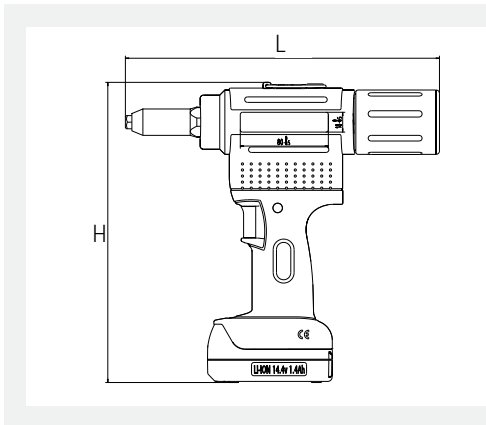

RIVETING CAPACITY FOR BLIND RIVETS

Ø 3/32" up to 3/16"

Ø 2.4 up to 4.8 mm

All Materials



WEIGHT	3.75 lbs	1.7 kg
L x H	10.75" x 11.22"	273 x 285 mm
STROKE	0.80"	20 mm
PULLING FORCE	2698 lbs	12.0 kn
MATERIAL	PE	
ITEM CODE	22660 10101	



INCLUDED EQUIPMENT SET

NOSE PIECES	3/32", 1/8", 5/32", 3/16"	2.4, 3.2, 4.0, 4.8 mm
QUICK CHANGE BATTERY	Li-Ion 14.4 V / 1.4 Ah	
CHARGER	14.4 V Li-Ion	
ABS CASE	1.48' x 1.15' x .36'	45 x 35 x 11 cm



GO-100+ - LITHIUM-ION CORDLESS RIVET TOOL

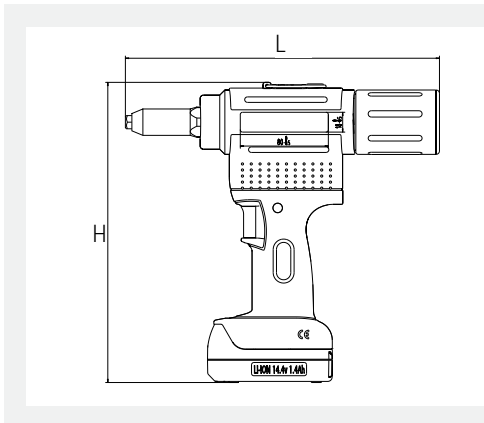

**RIVETING CAPACITY
FOR TRIPLE CLAW BLIND RIVETS**
 ϕ 3/16", 1/4", 9/32"
 ϕ 5.2, 6.4, 7.5 mm
 Aluminum



WEIGHT	3.75 lbs	1.7 kg
L x H	10.75" x 11.22"	273 x 285 mm
STROKE	0.80"	20 mm
PULLING FORCE	2698 lbs	12.0 kn
MATERIAL	PE	
ITEM CODE	22660 12101	



INCLUDED EQUIPMENT SET

NOSE PIECES	3/16", 1/4", 9/32"	5.2, 6.4, 7.5 mm
QUICK CHANGE BATTERY	Li-Ion 14.4 V / 1.4 Ah	
CHARGER	14.4 V Li-Ion	
ABS CASE	1.48' x 1.15' x .36'	45 x 35 x 11 cm



GO-200 - LITHIUM-ION CORDLESS RIVET TOOL

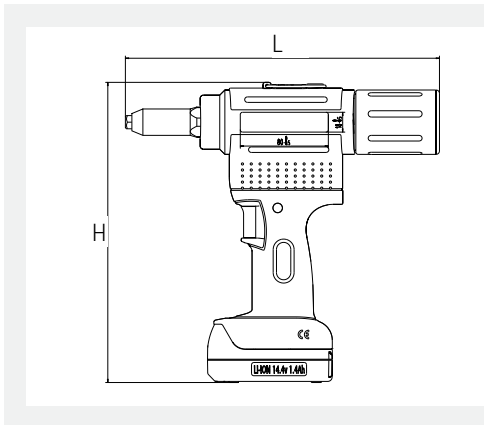

RIVETING CAPACITY FOR BLIND RIVETS

Ø 3/16" up to 1/4"

Ø 4.8 up to 6.4 mm

All Materials



WEIGHT	3.75 lbs	1.7 kg
L x H	10.75" x 11.22"	273 x 285 mm
STROKE	1.06"	27 mm
PULLING FORCE	4047 lbs	18.0 kn
MATERIAL	PE	
ITEM CODE	22660 20101	



INCLUDED EQUIPMENT SET

NOSE PIECES	1/8", 5/32", 3/16", 1/4" 3/16", 1/4" (Monobolt®)	3.2, 4.0, 4.8, 6.4 mm 4.8, 6.4 mm (Monobolt®)
QUICK CHANGE BATTERY	Li-Ion 14.4 V / 1.4 Ah	
CHARGER	14.4 V Li-Ion	
ABS CASE	1.48' x 1.15' x .36'	45 x 35 x 11 cm



GO-300-UN - LITHIUM-ION CORDLESS RIVET NUT TOOL

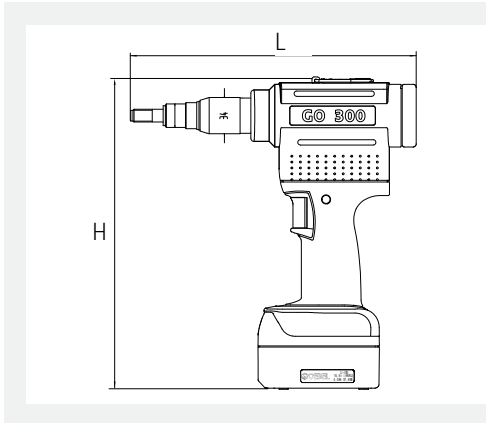

RIVETING CAPACITY FOR BLIND RIVET NUTS

#10 up to UNC 3/8

All Materials

UNC 1/2-13

Aluminum / Steel



WEIGHT	3.80 lbs	1.72 kg
L x H	10.55" x 11.22"	268 x 285 mm
STROKE	.32"	8 mm
PULLING FORCE	5400 lbs	24.0 kn
MATERIAL	PE	
ITEM CODE	22660 30102	



INCLUDED EQUIPMENT SET

MANDRELS & ANVILS	10-24 UNC, 10-32 UNF, 1/4-20 UNC, 5/16-18 UNC, 3/8-16 UNC, 1/2-13 UNC	
QUICK CHANGE BATTERY	14.4 V Li-Ion / 4.0 Ah / 57.6 Wh	
CHARGER	14.4 V Li-Ion	
ABS CASE	1.48' x 1.15' x .36'	45 x 35 x 11 cm

GO-400 - LITHIUM-ION CORDLESS TOOL FOR PIN & COLLAR

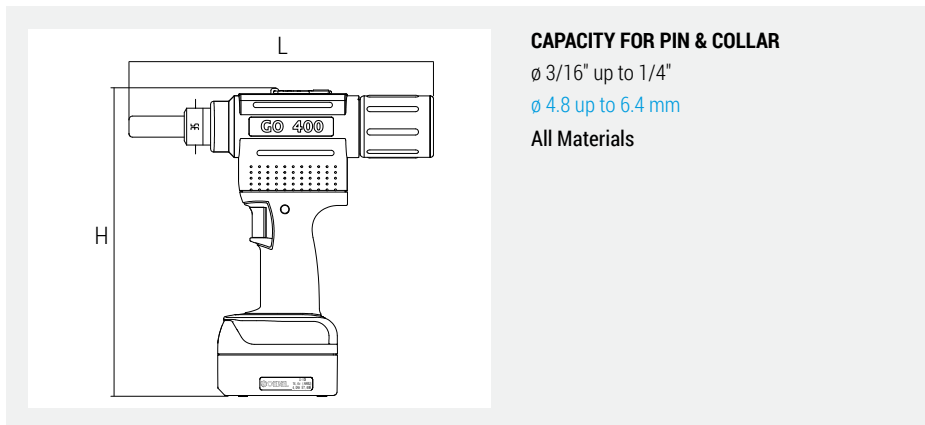

CAPACITY FOR PIN & COLLAR

∅ 3/16" up to 1/4"

∅ 4.8 up to 6.4 mm

All Materials



WEIGHT	3.70 lbs	1.68 kg
L x H	11.42" x 11.22"	290 x 285 mm
STROKE	.83"	21 mm
PULLING FORCE	4500 lbs	20.0 kn
MATERIAL	PE	
ITEM CODE	22660 40102	



INCLUDED EQUIPMENT SET

NOSE PIECES (*ACCORDING "C6L"-STANDARD)	1/4"	6.4 mm
QUICK CHANGE BATTERY	14.4 V Li-Ion / 4.0 Ah / 57.6 Wh	
CHARGER	14.4 V Li-Ion	
ABS CASE	1.48' x 1.15' x .36'	45 x 35 x 11 cm

OPTIONAL PARTS

NOSE PIECES (*ACCORDING "C6L"-STANDARD)	3/16"	4.8 mm
---	-------	--------

GOEBEL Locations Worldwide



UNITED STATES OF AMERICA

GOEBEL FASTENERS INC.
5650 GUHN ROAD, SUITE 110
HOUSTON, TX 77040
TEL.: +1- (713) 393 7007
E-MAIL: SALES@GOEBELFASTENERS.COM
WEB: WWW.GOEBELFASTENERS.COM

GERMANY

GOEBEL GMBH
SCHRAUB- UND VERBINDUNGSTECHNIK
MÜHLENSTRASSE 2-4
D-40699 ERKRATH
TEL.: +49-(0) 211-245000-0
FAX: +49-(0) 211-245000-250
E-MAIL: DE@GOEBEL-GROUP.COM
WEB: WWW.GOEBEL-GROUP.COM

FRANCE

SOCIÉTÉ GOEBEL
VIS ET TECHNIQUES DE FIXATION
LE DÔME, 1 RUE DE LA HAYE, BP 12910
F-95731 ROISSY CDG CEDEX
TEL.: +33-(0) 1-82887280
FAX: +33-(0) 1-82887281
E-MAIL: FR@GOEBEL-GROUP.COM
WEB: WWW.GOEBEL-GROUP.COM

NETHERLANDS

GOEBEL BV
SCHROEF- EN VERBINDINGSTECHNIEK
ARESSTRAAT 13-02/04
NL-5048 CD TILBURG
TEL.: +31-(0) 13-5720229
FAX: +31-(0) 13-5720239
E-MAIL: NL@GOEBEL-GROUP.COM
WEB: WWW.GOEBEL-GROUP.COM

POLAND

GOEBEL POLSKA SP.Z.O.O.
UL.TOPOLOWA 1
PL-05-805 KANIE
TEL.: +48-(0) 22-7593678
E-MAIL: PL@GOEBEL-GROUP.COM
WEB: WWW.GOEBEL-GROUP.COM

LATIN AMERICA

GOEBEL FASTENERS S DE RL DE CV
LOPE DE VEGA 209 COL. POLANCO
DEL. MIGUEL HIDALGO C.P. 11560
CIUDAD DE MÉXICO
TEL.: +52-55 03 39 83
E-MAIL: VENTAS@GOEBELFASTENERS.MX
WEB: WWW.GOEBELFASTENERS.MX