

K-Tool, Inc.



www.ktoolinc.com

Catalog 14

Pioneers in Productivity

K-Tool, Inc.
99 Enterprise Drive
New Oxford, PA 17350-9253

Phone: 800-377-3056
717-624-3866

Fax: 717-624-4105
Email: info@ktoolinc.com

GUARANTEE

We guarantee all of our products to be free from defects in workmanship and material. If any defects are apparent, the item will be replaced at no charge.

K-Tool, Inc. accepts no liability for any consequential damage to persons or equipment beyond the guarantee stated above.

POLICIES
CONDITION OF SALE

All sales are made in accordance with our standard conditions of sale which is current at the time orders are accepted. All of the specifications and prices are subject to change without notice.

TERMS OF PAYMENT

All invoices are NET 30 DAYS from date of invoice. All accounts with invoices past 60 days will be placed on credit hold.

SHIPPING & PROCESSING

All orders are sent via UPS. We will ship orders Freight Collect, although correct info must be provided or additional charges may apply. All in stock items ship the same day if order is received before **3:00 p.m. EST**. We do not ship orders on weekends or holidays.

RETURNS

All returns must have prior authorization and may be subject to a 15% restocking charge. After evaluating returns a credit will be issued - **WE DO NOT ACCEPT DEBIT MEMOS.**

MINIMUM ORDER

The minimum order is \$100.00 list. Orders under \$100.00 will be charged with a \$10.00 small order fee.

TEST TOOL POLICY

We will ship cutter bodies and inserts on performance purchase order numbers after the guaranteed test form information is supplied. K-TOOL, INC. will cover the tool bodies only. No credit will be given on used inserts, however credit will be issued on unused inserts. Items will be invoiced at the time of shipment. All test tools must be paid for or returned within 60 days. **Refer to page 166 for test form.**

Click on any of the tool names below to go directly to that section of the catalog.

	Special Tools		4 - 9
	Inserts		10 - 15
	Spot Drills	SDCS	16 - 24
	Flat Bottom Drills	FB	25 - 32
	Drill Sergeants	DS - DSL	33 - 40
	Drill Mills	DM - XDM	41 - 46
	Drill Mill Twins	DMT - XDMT	47 - 51
	Drill Mill Twin Long Edge	DMTL	52 - 54
	FEC-Mills	FEC	55 - 58
	Counterbore Tools	CBN - CB - CH - BCB	59 - 66
	Octa-Mills	HDOC - OC - XOC	67 - 71
	Dual Octa-Mills	DOC	72 - 74
	Button Cutters	BC	75 - 81
	Chamfer Products	A - AC - ACR - CMR OD - CC - CCS - DCR	82 - 98
	Dovetail Cutters	DT	99 - 102
	Mini Mills	MM - XMM	103 - 104
	Radius Mills	RM - RML - RMS - XRM	105 - 110
	Keli-Mills	KE - KEL	111 - 114
	Serators	S - SM - V50	115 - 121
	Super Alloy Mills	SA - SAL	122 - 126
	Eight Square Positive Mills	ESP - ESPS	127 - 129
	Stockbusters	SB - V50SB	130 - 132
	Universal Mills	UM	133 - 135
	T-Slot & Radius Cutters	TS - TSK - TSR	136 - 142
	Slotting Cutters	SC - SCSM - SCR - SCRSM	143 - 164
	Test Tool & Screw Torque Info.		165 - 166

ALL K-TOOL, INC. PRODUCTS ARE MADE IN THE



Special Tools

Fastest Delivery Time in the Industry!



Quotes & Tool Prints Normally Supplied in **2 - 3 Days**

Delivery on Less Complex Special Tooling : **5 - 8 Days**

Delivery on More Complex Special Tooling : **2 - 3 Weeks**

ALL SPECIAL TOOLING WILL BE MADE WITH K-TOOL, INC. INSERTS

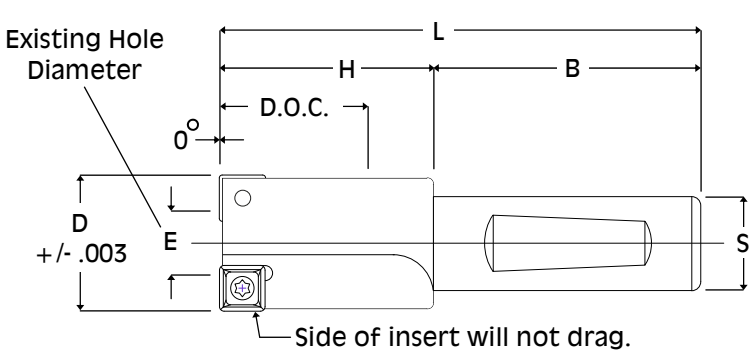
C-Bore / Core Drill		D	
C-Bore tools will be made with 2 flutes.		E	
		L	
		H	
		B	
		D.O.C.	
		S	
		Shank Type:	
<input type="checkbox"/> Weldon Flat / <input type="checkbox"/> Tapered Flat / <input type="checkbox"/> Straight Flat / <input type="checkbox"/> No Flat		<input type="checkbox"/> Yes / <input type="checkbox"/> No	

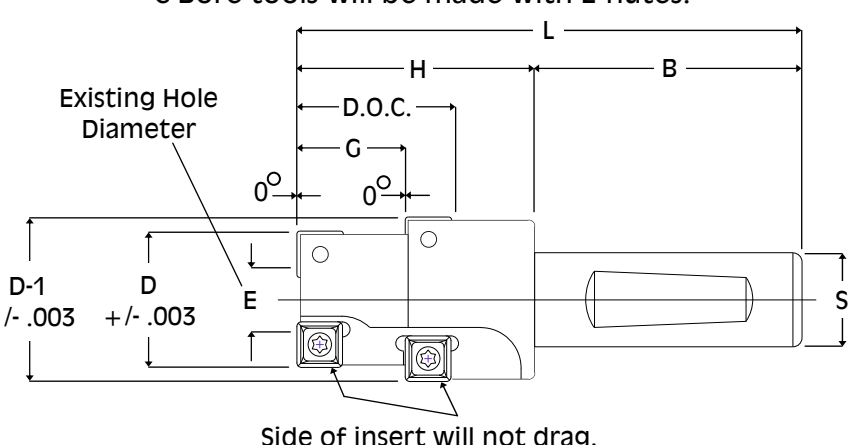
Dual C-Bore Tool		D-1			
C-Bore tools will be made with 2 flutes.		D			
		L			
		H			
		B			
		D.O.C.			
		G			
		S			
		Shank Type:		Coolant Thru:	
		<input type="checkbox"/> Weldon Flat / <input type="checkbox"/> Tapered Flat / <input type="checkbox"/> Straight Flat / <input type="checkbox"/> No Flat		<input type="checkbox"/> Yes / <input type="checkbox"/> No	

Contact Information	
Distributor	
Salesperson	
Email	
Phone #	
Fax #	
Enduser	
Phone #	

Application Information	
Mill or Lathe	
Spindle Taper	
Horsepower	
Work Piece Material	
Work Piece Hardness	

Drill & C-Bore Tool		D	
		E	
		L	
		H	
		B	
		D.O.C.	
		G	
		S	
Shank Type:		Coolant Thru:	
<input type="checkbox"/> Weldon Flat / <input type="checkbox"/> Tapered Flat / <input type="checkbox"/> Straight Flat / <input type="checkbox"/> No Flat		<input type="checkbox"/> Yes / <input type="checkbox"/> No	
Tool Style:			
DS Style		FB Style	

Drill & Chamfer Tool		D	
		E	
		L	
		H	
		B	
		D.O.C.	
		A°	
		S	
Shank Type:		Coolant Thru:	
<input type="checkbox"/> Weldon Flat / <input type="checkbox"/> Tapered Flat / <input type="checkbox"/> Straight Flat / <input type="checkbox"/> No Flat		<input type="checkbox"/> Yes / <input type="checkbox"/> No	
Tool Style:			
DS Style		CB Style Existing Hole Dia. = <input style="width: 50px;" type="text"/>	
		FB Style	

Contact Information	
Distributor	
Salesperson	
Email	
Phone #	
Fax #	
Enduser	
Phone #	

Application Information	
Mill or Lathe	
Spindle Taper	
Horsepower	
Work Piece Material	
Work Piece Hardness	

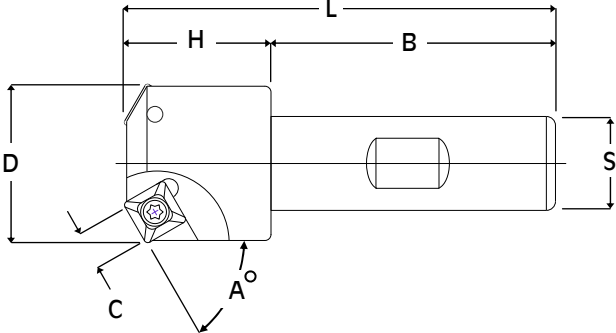
Chamfer Mill		D	
		L	
		H	
		B	
		C	
		A°	
		S	
		Application: <input type="checkbox"/> Plunging / <input type="checkbox"/> Milling	
Shank Type: <input type="checkbox"/> Weldon Flat / <input type="checkbox"/> Tapered Flat / <input type="checkbox"/> Straight Flat / <input type="checkbox"/> No Flat			

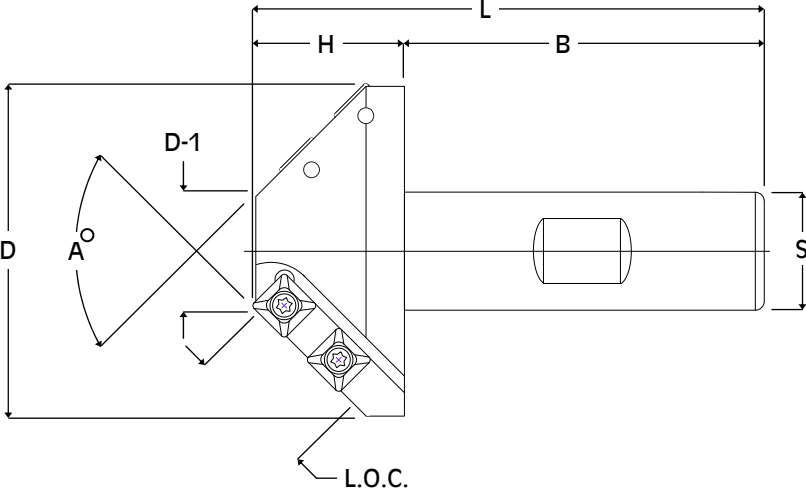
Long Edge Chamfer Mill		D	
		A°	
		D-1	
		L	
		H	
		B	
		L.O.C	
		S	
Application: <input type="checkbox"/> Plunging / <input type="checkbox"/> Milling			
Shank Type: <input type="checkbox"/> Weldon Flat / <input type="checkbox"/> Tapered Flat / <input type="checkbox"/> Straight Flat / <input type="checkbox"/> No Flat			

Contact Information	
Distributor	
Salesperson	
Email	
Phone #	
Fax #	
Enduser	
Phone #	

Application Information	
Mill or Lathe	
Spindle Taper	
Horsepower	
Work Piece Material	
Work Piece Hardness	

Shell Mount Long Edge Chamfer Mill

D	
D-1	
A°	
L	
L.O.C	
Bore	

Application:
 Plunging / Milling

Back C-Bore Tool

D	
Existing Hole Dia.	
D.O.C.	
L-1	
L	
S	

Shank Type:
 Weldon Flat / Straight Flat

Contact Information	
Distributor	
Salesperson	
Email	
Phone #	
Fax #	
Enduser	
Phone #	

Application Information	
Mill or Lathe	
Spindle Taper	
Horsepower	
Work Piece Material	
Work Piece Hardness	

Slotting Cutter / Half Side Mill

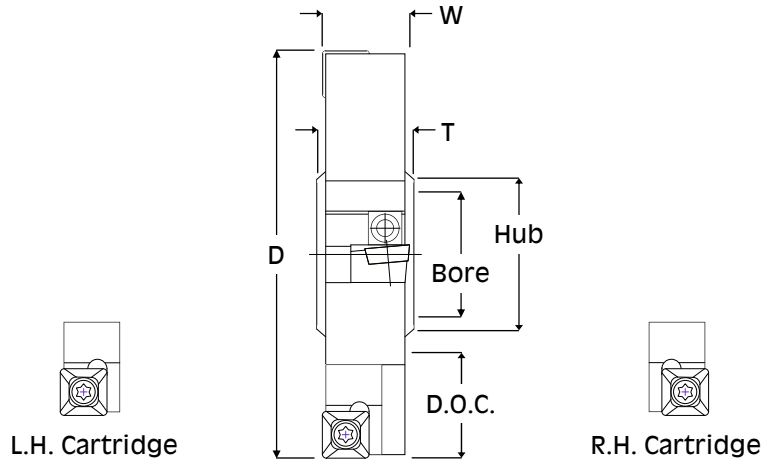

D	
W	If Half Side Mill <input type="checkbox"/> R.H. or <input type="checkbox"/> L.H. If Full Slot W.O.C. =
D.O.C.	
Bore	
Hub	<input type="checkbox"/> Yes or <input type="checkbox"/> No
T	

Mounting Style: Arbor / Shell

T-Slot Cutter

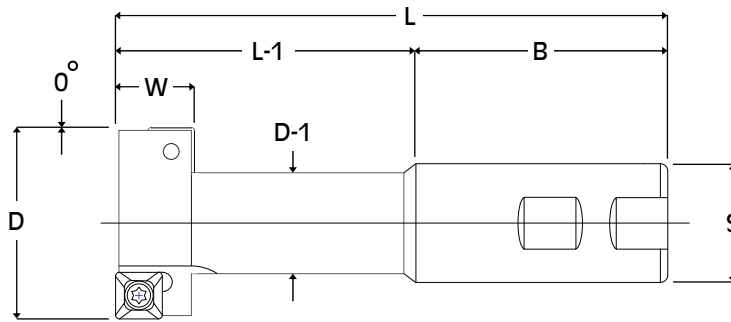

D	
W	
L	
L-1	
B	
D-1	
S	

Shank Type: Weldon Flat / Straight Flat / No Flat

Contact Information

Distributor	
Salesperson	
Email	
Phone #	
Fax #	
Enduser	
Phone #	

Application Information

Mill or Lathe	
Spindle Taper	
Horsepower	
Work Piece Material	
Work Piece Hardness	

Inserts

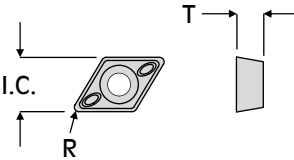
<i>DDEB / Positive Top</i>					<i>Available Grades</i>	
	Insert #	I.C.	T	R	X33	X40
	DDEB-2151P	.250	.095	.015	+	+

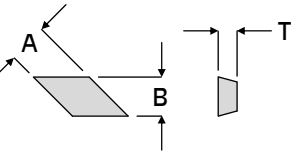
<i>DDG / Flat Top</i>					<i>Available Grade</i>	
	Insert #	A	B	T	X33	
	DDG-45	.190	.187	.093	+	

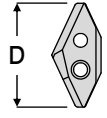
<i>DI</i>			<i>Available Grade</i>			<i>Available Grade</i>			<i>Available Grade</i>						
	Insert #	D	X33			Insert #	D	X33			Insert #	D	X33		
	DI-343	.3438	+			DI-687	.6875	+			DI-1062	1.0625	+		
	DI-375	.3750				DI-718	.7188				DI-1093	1.0938			
	DI-406	.4062				DI-750	.7500				DI-1125	1.1250			
	DI-421	.4219				DI-765	.7656				DI-1156	1.1562			
	DI-437	.4375				DI-781	.7812				DI-1187	1.1875			
	DI-468	.4688				DI-812	.8125				DI-1218	1.2188			
	DI-500	.5000				DI-843	.8438				DI-1250	1.2500			
	DI-515	.5156				DI-875	.8750				DI-1281	1.2812			
	DI-531	.5312				DI-906	.9062				DI-1312	1.3125			
	DI-562	.5625				DI-921	.9219				DI-1343	1.3438			
	DI-578	.5781				DI-937	.9375				DI-1375	1.3750			
	DI-593	.5938				DI-968	.9688				DI-1406	1.4062			
	DI-625	.6250				DI-984	.9840				DI-1437	1.4375			
	DI-640	.6400				DI-1000	1.000				DI-1468	1.4688			
	DI-656	.6562				DI-1031	1.0312				DI-1500	1.5000			
	DI-669	.6693													

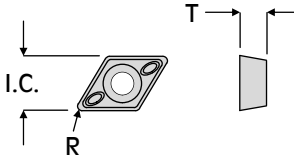
<i>DPEB / Positive Top</i>					<i>Available Grade</i>	
	Insert #	I.C.	T	R	X33	
	DPEB-3252P	.375	.160	.031	+	

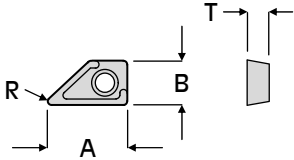
<i>DTI / Positive Top</i>					<i>Available Grade</i>		
	Insert #	B	A	T	R	X33	
	DTI-1511P	.187	.328	.082	.015	+	

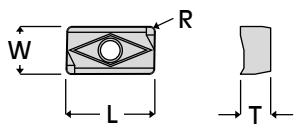
<i>LPMT / Positive Top</i>					<i>Available Grades</i>		
	Insert #	R	L	W	T	B1M	X33
	LPMT-52-532	.031	.600	.320	.208	+	+
	LPMT-52-533	.047	.600	.320	.208	-	
	LPMT-52-534	.062	.600	.320	.208	-	

Inserts

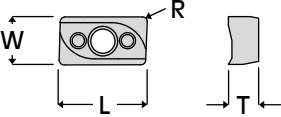
<i>MGH / Positive Top</i>						<i>Available Grades</i>	
	Insert #	R	L	W	T	B1M	X33
	MGH-151	.002	.250	.170	.080	+	+
	MGH-1510	.008	.250	.170	.080	-	
	MGH-1511	.015	.250	.170	.080	-	
	MGH-2321	.015	.400	.250	.140	-	
	MGH-2322	.031	.400	.250	.140	+	
	MGH-2323	.047	.400	.250	.140	-	
	MGH-2324	.062	.400	.250	.140	-	
	MGH-531A	.015	.562	.313	.190	-	
	MGH-532A	.031	.562	.313	.190	+	
	MGH-534A	.062	.562	.313	.190	-	
	MGH-536A	.093	.562	.313	.190	-	
	MGH-538A	.125	.562	.313	.190	-	
	MGH-5310B	.156	.562	.313	.190	-	
	MGH-5312B	.187	.562	.313	.190	-	
	MGH-5314B	.218	.562	.313	.190	-	
MGH-5316B	.250	.562	.313	.190	-		

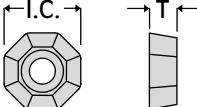
<i>ODEB / Positive Top</i>				<i>Available Grades</i>	
	Insert #	I.C.	T	B1M	X33
	ODEB-2711	.343	.110	-	+
	ODEB-2721	.343	.130	+	

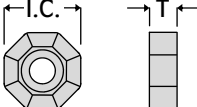
<i>ONEB / Positive Top - Single Sided</i>				<i>Available Grade</i>
	Insert #	I.C.	T	A10M
	ONEB-85P	1.000	.312	+

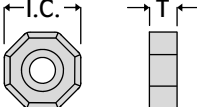
<i>ONMB / Positive Top - Double Sided</i>				<i>Available Grade</i>
	Insert #	I.C.	T	A10M
	ONMB-85	1.000	.312	+

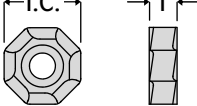
<i>ONPG / Positive Top - Double Sided</i>				<i>Available Grade</i>
	Insert #	I.C.	T	X33
	ONPG-4532	.593	.220	+

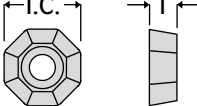
<i>OPEB / Positive Top</i>				<i>Available Grades</i>			
	Insert #	I.C.	T	A9M	B1M	X33	X40
	OPEB-535	.625	.220	+	-	+	-
	OPEB-535XP	.625	.220	-	+	-	+

Inserts

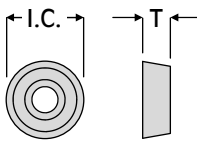
<i>RCEB / Positive Top</i>						<i>Available Grades</i>		
	Insert #	I.C.	T	Ground	Molded	A10M	B1M	X33
	RCEB-22	.250	.125	-	+	+	-	+
	RCEB-22G	.250	.125	+	-	-	+	
	RCEB-325	.375	.156	-	+	+	-	
	RCEB-325G	.375	.156	+	-	-	+	
	RCEB-435	.500	.220	-	+	+	-	
	RCEB-435G	.500	.220	+	-	-	+	
	RCEB-64	.750	.250	-	+	+	-	

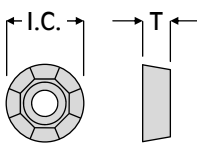
<i>RDEB / Positive Top</i>				<i>Available Grade</i>
	Insert #	I.C.	T	X33
	RDEB-2711	.343	.110	+
	RDEB-2721	.343	.130	

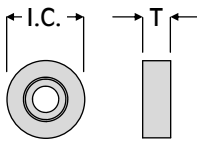
<i>RNEB / Positive Top - Single Sided</i>				<i>Available Grade</i>
	Insert #	I.C.	T	A10M
	RNEB-85P	1.000	.312	+

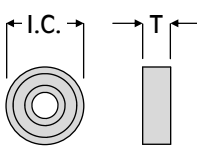
<i>RNMB / Positive Top - Double Sided</i>				<i>Available Grade</i>
	Insert #	I.C.	T	A10M
	RNMB-85	1.000	.312	+

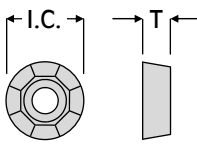
<i>RPEB / Positive Top</i>				<i>Available Grade</i>
	Insert #	I.C.	T	X33
	RPEB-535	.625	.220	+

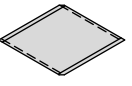
<i>SDCS / 60°</i>		<i>Available Grades</i>	
	Insert #	A1M	B1M
	601	+	+
	602	+	+

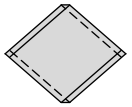
<i>SDCS / 82°</i>		<i>Available Grades</i>	
	Insert #	A1M	B1M
	820	+	+
	821		
	822		
	823		

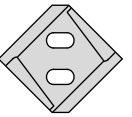
<i>SDCS / 90°</i>		<i>Available Grade</i>
	Insert #	A1M
	90-500	+
	90-625	
	90-750	

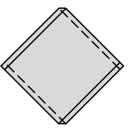
<i>SDCS / 90°</i>		<i>Available Grades</i>		
	Insert #	A1M	B1M	CPM4
	90	+	+	-
	900	+	+	+
	901	+	+	
	902	+	+	
	9025	+	+	
	903	+	+	

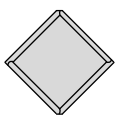
<i>SDCS / 90° Chipbreaker</i>		<i>Available Grades</i>		
	Insert #	A1M	B1M	CPM4
	901CB	+	+	+
	902CB	+	+	+
	9025CB	+	-	-
903CB	-	-	+	

Inserts

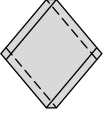
<i>SDCS / 100°</i>		<i>Available Grades</i>	
	Insert #	A1M	B1M
	100	+	+
	1001	+	+
	1002	+	-

<i>SDCS / 135°</i>		<i>Available Grades</i>	
	Insert #	A1M	B1M
	1351	+	+
	1352		

<i>SDCS / 120°</i>		<i>Available Grades</i>	
	Insert #	A1M	B1M
	1201	+	+
	1202		

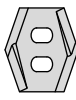
<i>SDCS / 142°</i>		<i>Available Grade</i>	
	Insert #	A1M	
	142-500	+	
	142-750		

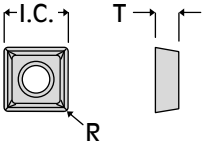
<i>SDEB / Chipbreaker</i>					<i>Available Grade</i>	
	Insert #	I.C.	T	R	X33	
	SDEB-1511CB	.187	.082	.015	+	
	SDEB-2151CB	.250	.093			
	SDEB-2522CB	.312	.125	.031		

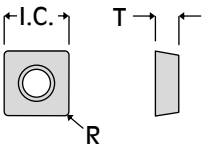
<i>SDEB / Flat Top</i>					<i>Available Grades</i>	
	Insert #	I.C.	T	R	A1M	X33
	SDEB-2151F	.250	.093	.015	+	+

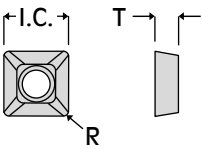
<i>SDEB / Positive Top</i>					<i>Available Grade</i>	
	Insert #	I.C.	T	R	X33	
	SDEB-2151P	.250	.093	.015	+	
	SDEB-2521P	.312	.125			
	SDEB-2522P			.031		

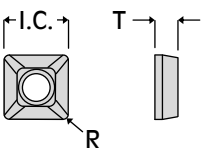
<i>SNEB / Positive Top</i>					<i>Available Grades</i>	
	Insert #	I.C.	T	R	A9M	X33
	SNEB-432PA	.500	.187	.031	+	+

Inserts

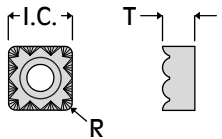
<i>SNGC / H Series - Serator Inserts</i>					<i>Available Grade</i>	
	Insert #	I.C.	T	R	X33	
	SNGC-333H	.375	.187	.047	+	
	SNGC-444H	.500	.250	.062		

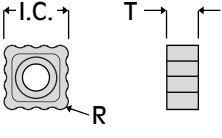
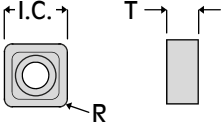
<i>SNMC / Serator Inserts</i>					<i>Available Grades</i>	
B Series 	Insert #	I.C.	T	R	A9M	X33
	SNMC-222B	.250	.125	.031	-	+
	SNMC-333B	.375	.187	.047		
SNMC-444B	.500	.250	.062			
P Series 	SNMC-221P	.250	.125	.015	+	
	SNMC-332P	.375	.187	.031		
	SNMC-443P	.500	.250	.047		

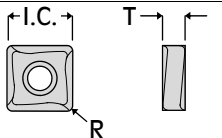
<i>SNPG / Positive Top - Double Sided</i>					<i>Available Grade</i>	
	Insert #	I.C.	T	R	X33	
	SNPG-2522	.312	.125	.031	+	
	SNPG-3532	.437	.187	.031		

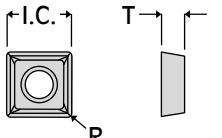
<i>SPEB / Chipbreaker</i>					<i>Available Grades</i>	
	Insert #	I.C.	T	R	X40	X33
	SPEB-1511CB	.187	.082	.015	+	+
	SPEB-1512CB	.187	.082	.031	-	
	SPEB-221CB	.250	.125	.015	+	
	SPEB-222CB	.250	.125	.031	-	
	SPEB-2521CB	.312	.125	.015	-	
	SPEB-2522CB	.312	.125	.031	+	
	SPEB-322CB	.375	.125		+	
	SPEB-332CB	.375	.187		+	
	SPEB-422CB	.500	.125		-	
	SPEB-432CB	.500	.187		+	
	SPEB-532CB	.625	.187		-	
	SPEB-6352CB	.750	.220		+	
	SPEB-842CB	1.000	.250		+	

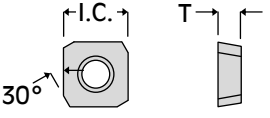
<i>SPEB / Flat Top - 30° Lead</i>					<i>Available Grade</i>	
	Insert #	I.C.	T		X33	
	SPEB-43-30F	.500	.187		+	

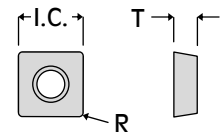
<i>SPEB / Flat Top</i>					<i>Available Grades</i>	
	Insert #	I.C.	T	R	A1M	X33
	SPEB-222F	.250	.125	.031	+	+
	SPEB-322F	.375				
SPEB-422F	.500					

Inserts

SPEB / Positive Top - 30° Lead				Available Grade
	Insert #	I.C.	T	X33
	SPEB-43-30PA	.500	.187	+

SPEB / Positive Top					Available Grades					
	Insert #	I.C.	T	R	A1M	A9M	B1M	X40	X33	
	SPEB-220P	.250	.125	.003	-	-	-	-	-	
	SPEB-221P	.250	.125	.015	-	-	-	-	-	
	SPEB-222P	.250	.125	.031	+	+	+	-	-	
	SPEB-2521P	.312	.125	.015	-	-	-	-	-	
	SPEB-2522P	.312	.125	.031	+	+	+	+	+	
	SPEB-321P	.375	.125	.015	-	-	-	-	-	
	SPEB-322P	.375	.125	.031	+	+	+	+	+	
	SPEB-331P	.375	.187	.015	-	-	-	-	-	
	SPEB-332P	.375	.187	.031	+	+	+	+	+	
	SPEB-333P	.375	.187	.047	+	-	-	-	-	
	SPEB-334P	.375	.187	.062	-	-	-	-	+	
	SPEB-3522PA	.437	.125	.031	-	-	-	-	-	+
	SPEB-422PA	.500	.125	.031	-	-	-	-	-	
	SPEB-431PA	.500	.187	.015	-	-	-	-	-	
	SPEB-432PA	.500	.187	.031	+	+	+	+	+	
	SPEB-433PA	.500	.187	.047	+	-	-	-	-	
	SPEB-433PA Wiper	.500	.187	.047	-	-	-	-	-	
	SPEB-433PAQ	.500	.187	.047	-	-	-	-	-	
	SPEB-434PA	.500	.187	.062	-	-	-	-	+	
SPEB-43PA45	.500	.187	.05 X 45°	-	-	-	-	-		
SPEB-532PA	.625	.187	.031	-	-	-	-	-		
SPEB-6352PA	.750	.220	.031	-	-	-	-	+		
SPEB-842PA	1.000	.250	.031	-	-	-	-	-		

Questions? Call 1-800-377-3056

Insert Grades

B1M	Uncoated Carbide - No Hone
A1M	TIN Coated
A9M	Advanced Multi-Layer PVD Coated Carbide
A10M	TIALN / TIN Coated Carbide / Wear Resistant Grade
X33	High Performance Nitride
X40	Extremely Smooth Boride Coating

Insert Grade Selection

Material	Material Examples	Preferred Grade
High & Low Carbon Steels	1018, 1020, 1117, 1141, 12L14	X33 / A10M
High Carbon & Alloy Steels	1045, 4140, 4340, 52100, 8620	X33 / A10M
Lower Carbon Tool Steels	P-20, H-13, S-7	X33 / A10M
Tool Steels	A-2, A-6, D-2, M-2	X33 / A10M
Stainless Steels	303, 304, 316, 420, 15-5PH, 17-4PH	X33 / A10M
Iron	Cast, Nodular	A9M
Iron	Ductile	X33 / A10M
Nickel & Titanium Alloys	Inconel, Hastelloy, TI-6AL-4V	X33 / A10M
Non-Ferrous Metals	Aluminum, Bronze, Brass	X40 / B1M / X33

Spot Drills

Insert Loading Procedure

- Air Blast Pocket Clean
- Hold Insert in place (Chisel points to front & rear)
 - Flatted corners are to prevent loading insert backwards
- Tighten clamps until each one makes light contact
- Alternate tightening screws several times until screws are tight

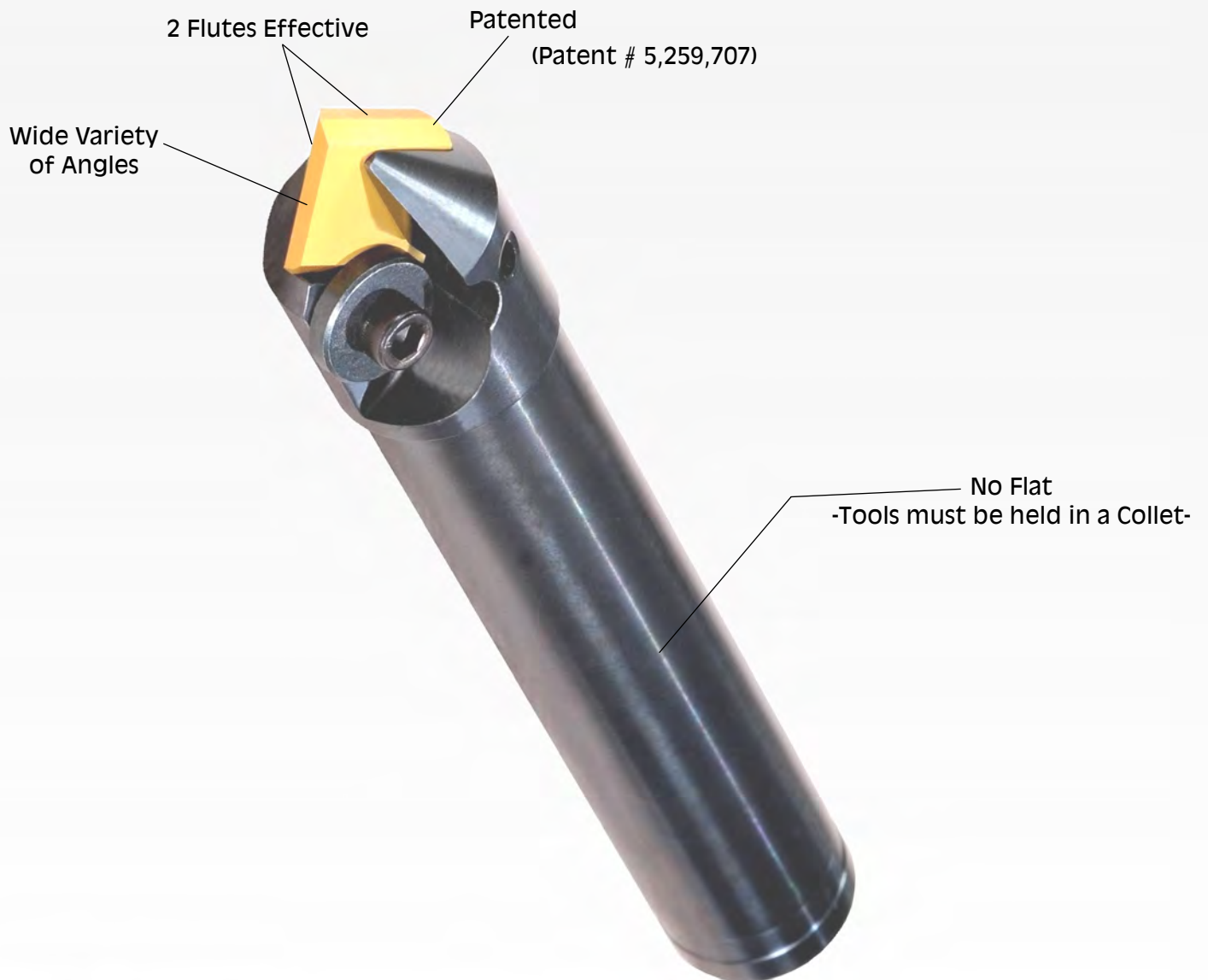

Applications

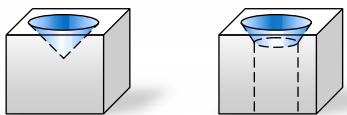

Spot Drills

60° Included

(Patent # 5,259,707)

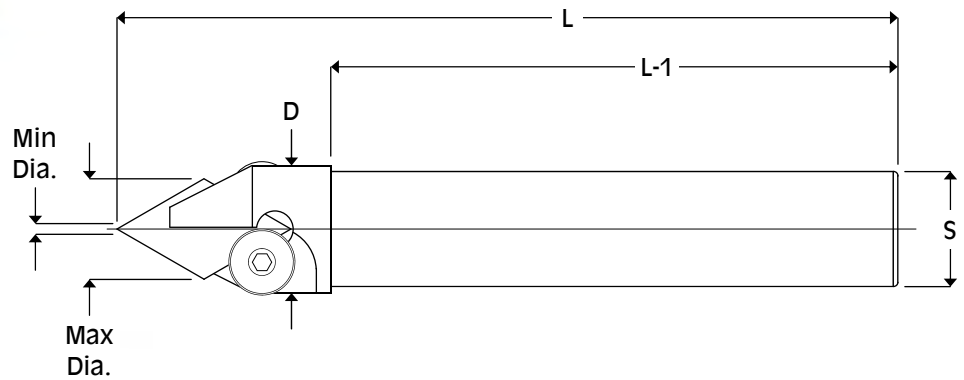

Tool Info.

Tool #	Min Dia.	Max Dia.	L	L-1	S	D	Clamp	Screw	Insert
SDCS-601L	.156	.540	5.450	4.250	.750	1.000	501912	103212	#601
SDCS-602L	.250	.750	6.700	4.875	1.000	1.120	621915	103212	#602

Speed and Feed Info.

Material	S.F.M.	I.P.R.	Insert Grades
Mild & Low Carbon Steel Ex. 1018, 1020, 1117, 1141, 12L14	500 - 700	.0024	AIM
High Carbon & Alloy Steel Ex. 1045, 4140, 4340, 52100, 8620	400 - 600	.0016	
Lower Carbon Tool Steel Ex. P-20, H-13, S-7	400 - 600	.002	
Tool Steel Ex. A-2, A-6, D-2, M-2	300 - 600	.002	
Stainless Steel Ex. 304, 316, 420, 15-5PH, 17-4PH	200 - 400	.0014	
Iron Ex. Cast, Ductile, Nodular	400 - 700	.004	
Nickel & Titanium Alloy Ex. Inconel, Hastelloy, Ti-6AL-4V	120 - 250	.0012	
Non-Ferrous Metal Ex. Aluminum, Bronze, Brass	1000 - 2000	.006	AIM BIM

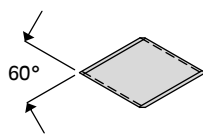

Insert Grades

Insert #	A1M	B1M
#601	+	+
#602	+	+

Spot Drills

82° Included

(Patent # 5,259,707)

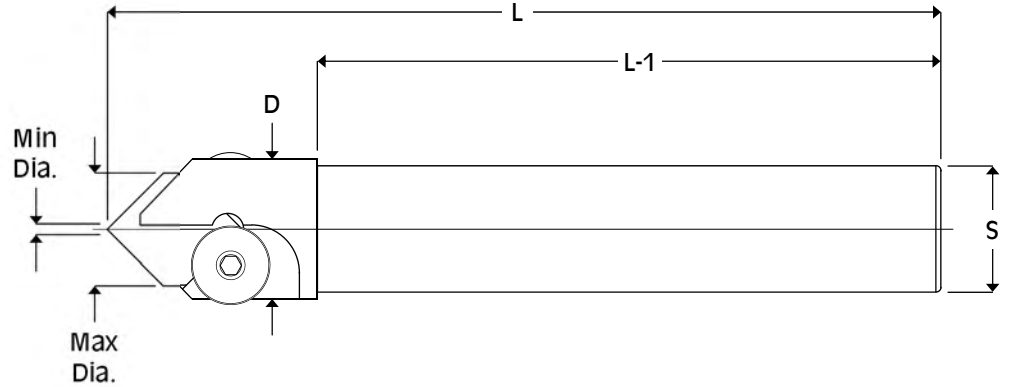

Tool Info.

Tool #	Min Dia.	Max Dia.	L	L-1	S	D	Clamp	Screw	Insert
SDCS-820	.093	.400	3.250	2.375	.500	.625	311205	44025	#820
SDCS-821L	.156	.580	5.360	4.250	.750	1.000	501912	103212	#821
SDCS-822L	.250	.880	6.535	4.875	1.000	1.120	621915	103212	#822
SDCS-823	.250	1.500	4.937	2.500	1.000	1.500	621915	103212	#823

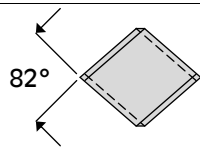

Insert Grades

Insert #	A1M	B1M
#820	+	+
#821	+	+
#822	+	+
#823	+	+

Speed and Feed Info.

Material	S.F.M.	I.P.R.	Insert Grades
Mild & Low Carbon Steel Ex. 1018, 1020, 1117, 1141, 12L14	500 - 700	.0024	A1M B1M
High Carbon & Alloy Steel Ex. 1045, 4140, 4340, 52100, 8620	400 - 600	.0016	
Lower Carbon Tool Steel Ex. P-20, H-13, S-7	400 - 600	.002	
Tool Steel Ex. A-2, A-6, D-2, M-2	300 - 600	.002	
Stainless Steel Ex. 304, 316, 420, 15-5PH, 17-4PH	200 - 400	.0014	
Iron Ex. Cast, Ductile, Nodular	400 - 700	.004	
Nickel & Titanium Alloy Ex. Inconel, Hastelloy, Ti-6AL-4V	120 - 250	.0012	
Non-Ferrous Metal Ex. Aluminum, Bronze, Brass	1000 - 2000	.006	

Spot Drills

90° Included

(Patent # 5,259,707)

- Designed for spotting along shoulders-
- Split point design for reduced cutting pressure-

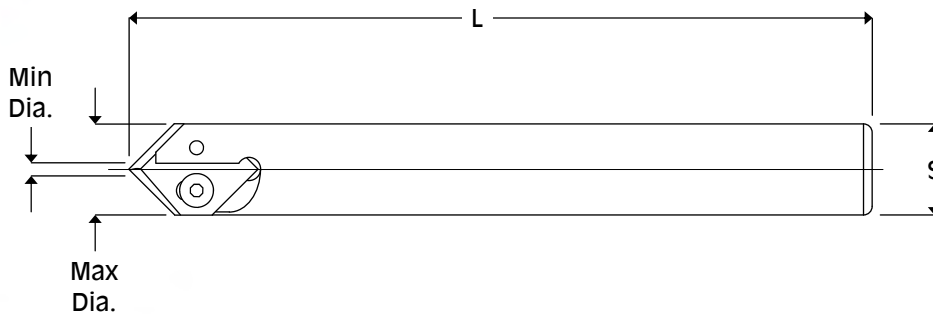

Tool Info.

Tool #	Min Dia.	Max Dia.	L	S	Washer	Screw	Wrench	Insert
SDCS-90-500	.093	.500	4.000	.500	251207	325B	1/16" Allen	#90-500
SDCS-90-625	.100	.625	5.000	.625	251207	425B	T-8	#90-625
SDCS-90-750	.125	.750	6.000	.750	251603	638B	T-10	#90-750

Speed and Feed Info.

Material	S.F.M.	I.P.R.	Insert Grade
Mild & Low Carbon Steel Ex. 1018, 1020, 1117, 1141, 12L14	500 - 700	.002 - .004	AIM
High Carbon & Alloy Steel Ex. 1045, 4140, 4340, 52100, 8620	400 - 600	.002 - .004	
Lower Carbon Tool Steel Ex. P-20, H-13, S-7	400 - 600	.002 - .004	
Tool Steel Ex. A-2, A-6, D-2, M-2	300 - 600	.002 - .004	
Stainless Steel Ex. 304, 316, 420, 15-5PH, 17-4PH	200 - 400	.002 - .004	
Iron Ex. Cast, Ductile, Nodular	400 - 700	.002 - .004	
Nickel & Titanium Alloy Ex. Inconel, Hastelloy, Ti-6AL-4V	120 - 250	.0012 - .0022	
Non-Ferrous Metal Ex. Aluminum, Bronze, Brass	1000 - 2000	.003 - .008	

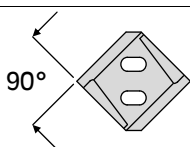

Insert Grade

Insert #	A1M
#90-500	+
#90-625	+
#90-750	+

(Patent # 5,259,707)

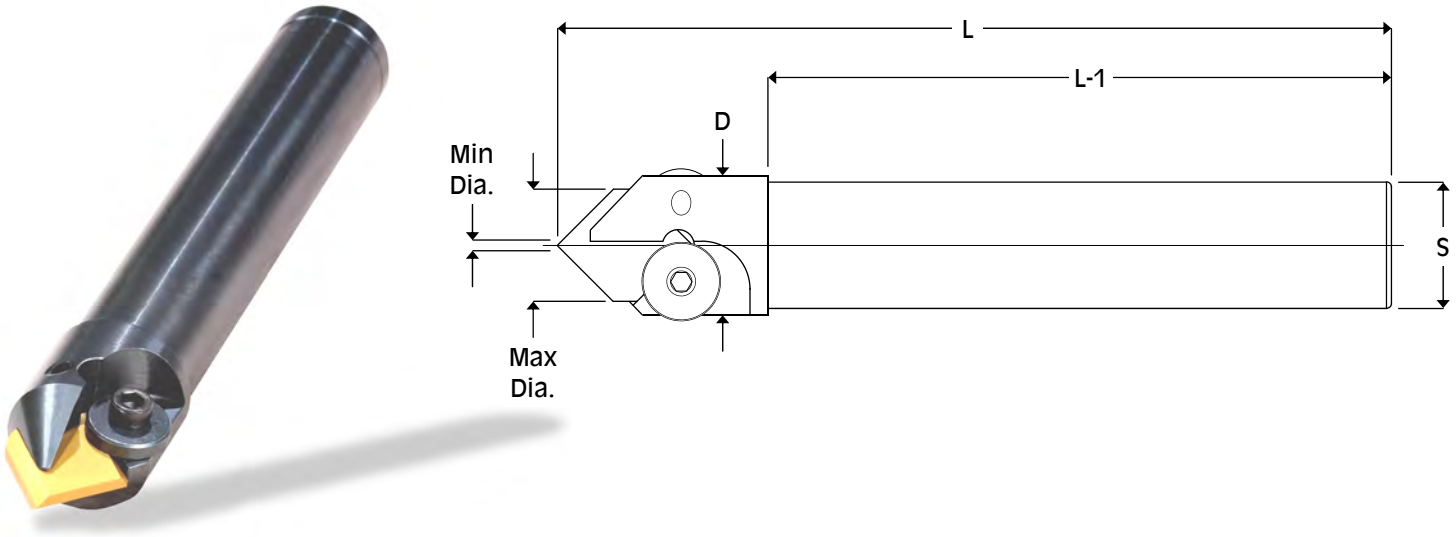

Tool Info.

Tool #	Min Dia.	Max Dia.	L	L-1	S	D	Clamp	Screw	Insert
SDCS-90	.070	.390	3.250	2.500	.375	.430	180310	25618	#90
SDCS-900	.093	.470	3.250	2.375	.500	.625	311205	44025	#900
SDCS-901	.156	.600	3.060	2.000	.500	1.000	501912	103212	#901
SDCS-901L	.156	.600	5.330	4.250	.750				
SDCS-902	.250	.900	4.130	2.500	.750	1.125	621915	103212	#902
SDCS-902L	.250	.900	6.530	4.875	1.000				
SDCS-9025	.250	1.270	4.690	2.625	1.000	1.250	621915	103212	#9025
SDCS-903	.375	1.560	4.880	2.625	1.000	1.700	102518	142812	#903

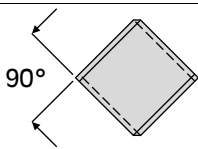

Insert Grades

Insert #	A1M	B1M	CPM4
#90	+	+	-
#900	+	+	+
#901	+	+	-
#901CB	+	+	+
#902	+	+	-
#902CB	+	+	+
#9025	+	+	-
#9025CB	+	-	-
#903	+	+	-
#903CB	-	-	+

Speed and Feed Info.

Material	S.F.M.	I.P.R.	Insert Grades
Mild & Low Carbon Steel Ex. 1018, 1020, 1117, 1141, 12L14	500 - 700	.0024	A1M B1M
High Carbon & Alloy Steel Ex. 1045, 4140, 4340, 52100, 8620	400 - 600	.0016	
Lower Carbon Tool Steel Ex. P-20, H-13, S-7	400 - 600	.002	
Tool Steel Ex. A-2, A-6, D-2, M-2	300 - 600	.002	
Stainless Steel Ex. 304, 316, 420, 15-5PH, 17-4PH	200 - 400	.0014	
Iron Ex. Cast, Ductile, Nodular	400 - 700	.004	
Nickel & Titanium Alloy Ex. Inconel, Hastelloy, Ti-6AL-4V	120 - 250	.0012	
Non-Ferrous Metal Ex. Aluminum, Bronze, Brass	1000 - 2000	.006	

Spot Drills

100° Included

(Patent # 5,259,707)

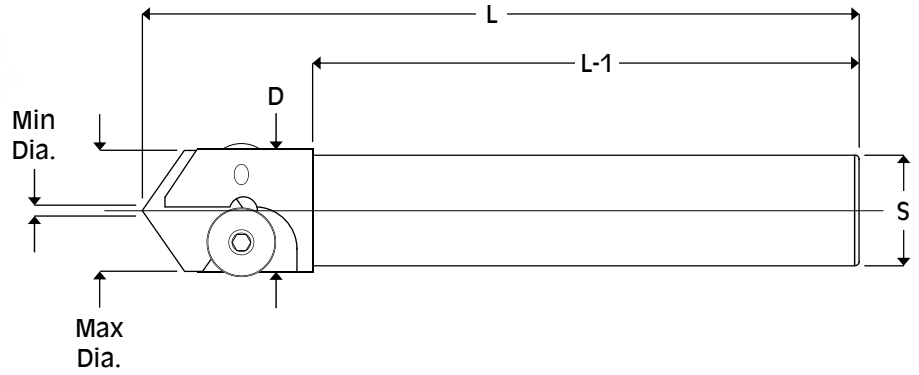

Tool Info.

Tool #	Min Dia.	Max Dia.	L	L-1	S	D	Clamp	Screw	Insert
SDCS-100	.093	.470	3.210	2.375	.500	.625	311205	44025	#100
SDCS-1001L	.156	.630	5.310	4.250	.750	1.000	501912	103212	#1001
SDCS-1002L	.250	1.030	6.500	4.875	1.000	1.125	621915	103212	#1002

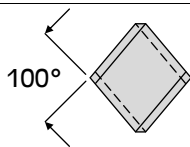

Insert Grades

Insert #	A1M	B1M
#100	+	+
#1001	+	+
#1002	+	-

Speed and Feed Info.

Material	S.F.M.	I.P.R.	Insert Grades
Mild & Low Carbon Steel Ex. 1018, 1020, 1117, 1141, 12L14	500 - 700	.0024	A1M B1M
High Carbon & Alloy Steel Ex. 1045, 4140, 4340, 52100, 8620	400 - 600	.0016	
Lower Carbon Tool Steel Ex. P-20, H-13, S-7	400 - 600	.002	
Tool Steel Ex. A-2, A-6, D-2, M-2	300 - 600	.002	
Stainless Steel Ex. 304, 316, 420, 15-5PH, 17-4PH	200 - 400	.0014	
Iron Ex. Cast, Ductile, Nodular	400 - 700	.004	
Nickel & Titanium Alloy Ex. Inconel, Hastelloy, Ti-6AL-4V	120 - 250	.0012	
Non-Ferrous Metal Ex. Aluminum, Bronze, Brass	1000 - 2000	.006	

(Patent # 5,259,707)

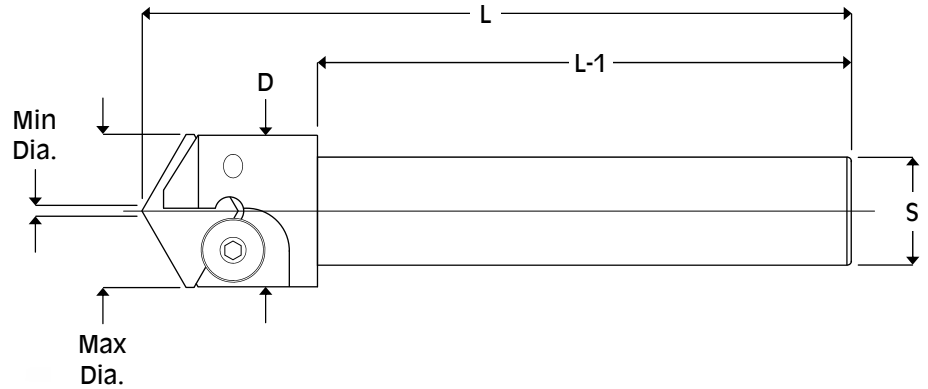

Tool Info.

Tool #	Min Dia.	Max Dia.	L	L-1	S	D	Clamp	Screw	Insert
SDCS-1201L	.156	.875	5.300	4.250	.750	1.000	501912	103212	#1201
SDCS-1202L	.250	1.300	6.437	4.875	1.000	1.350	621915	103212	#1202

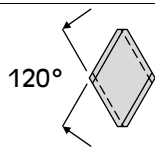

Insert Grades

Insert #	A1M	B1M
#1201	+	+
#1202	+	+

Speed and Feed Info.

Material	S.F.M.	I.P.R.	Insert Grades
Mild & Low Carbon Steel Ex. 1018, 1020, 1117, 1141, 12L14	500 - 700	.0024	A1M B1M
High Carbon & Alloy Steel Ex. 1045, 4140, 4340, 52100, 8620	400 - 600	.0016	
Lower Carbon Tool Steel Ex. P-20, H-13, S-7	400 - 600	.002	
Tool Steel Ex. A-2, A-6, D-2, M-2	300 - 600	.002	
Stainless Steel Ex. 304, 316, 420, 15-5PH, 17-4PH	200 - 400	.0014	
Iron Ex. Cast, Ductile, Nodular	400 - 700	.004	
Nickel & Titanium Alloy Ex. Inconel, Hastelloy, TI-6AL-4V	120 - 250	.0012	
Non-Ferrous Metal Ex. Aluminum, Bronze, Brass	1000 - 2000	.006	

Spot Drills

135° Included

(Patent # 5,259,707)

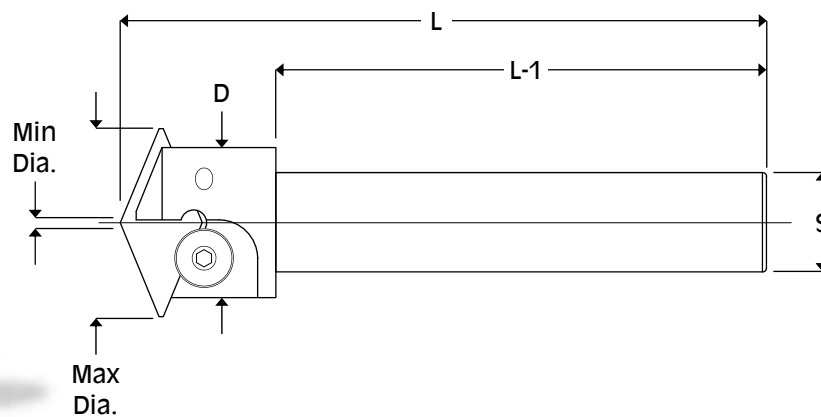

Tool Info.

Tool #	Min Dia.	Max Dia.	L	L-1	S	D	Clamp	Screw	Insert
SDCS-1351L	.156	1.062	5.290	4.250	.750	1.000	501912	103212	#1351
SDCS-1352L	.250	1.625	6.400	4.875	1.000	1.600	621915	103212	#1352

135°



Insert Grades

Insert #	A1M	B1M
#1351	+	+
#1352	+	+

Speed and Feed Info.

Material	S.F.M.	I.P.R.	Insert Grades
Mild & Low Carbon Steel Ex. 1018, 1020, 1117, 1141, 12L14	500 - 700	.0024	A1M B1M
High Carbon & Alloy Steel Ex. 1045, 4140, 4340, 52100, 8620	400 - 600	.0016	
Lower Carbon Tool Steel Ex. P-20, H-13, S-7	400 - 600	.002	
Tool Steel Ex. A-2, A-6, D-2, M-2	300 - 600	.002	
Stainless Steel Ex. 304, 316, 420, 15-5PH, 17-4PH	200 - 400	.0014	
Iron Ex. Cast, Ductile, Nodular	400 - 700	.004	
Nickel & Titanium Alloy Ex. Inconel, Hastelloy, Ti-6AL-4V	120 - 250	.0012	
Non-Ferrous Metal Ex. Aluminum, Bronze, Brass	1000 - 2000	.006	A1M B1M

Spot Drills

142° Included

(Patent # 5,259,707)

- Designed for spotting along shoulders-
- Split point design for reduced cutting pressure-

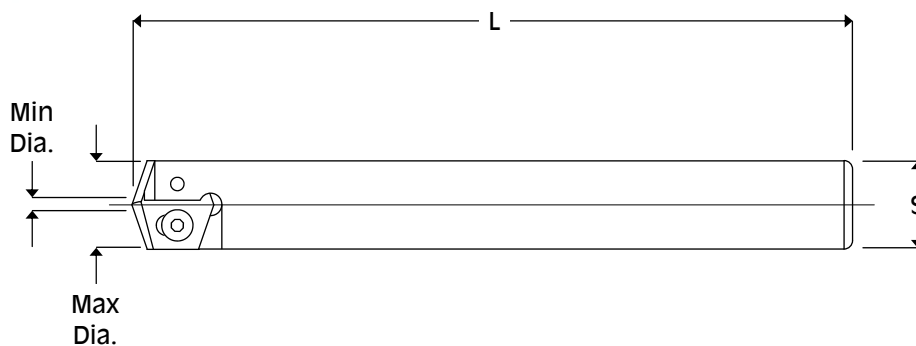

<i>Tool Info.</i>								
Tool #	Min Dia.	Max Dia.	L	S	Washer	Screw	Wrench	Insert
SDCS-142-500	.093	.500	4.000	.500	251207	325B	1/16" Allen	#142-500
SDCS-142-750	.125	.750	6.000	.750	251603	638B	T-10	#142-750

 142°	
<i>Insert Grade</i>	
Insert #	A1M
#142-500	+
#142-750	+

<i>Speed and Feed Info.</i>			
Material	S.F.M.	I.P.R.	Insert Grade
Mild & Low Carbon Steel <i>Ex. 1018, 1020, 1117, 1141, 12L14</i>	500 - 700	.002 - .004	A1M
High Carbon & Alloy Steel <i>Ex. 1045, 4140, 4340, 52100, 8620</i>	400 - 600	.002 - .004	
Lower Carbon Tool Steel <i>Ex. P-20, H-13, S-7</i>	400 - 600	.002 - .004	
Tool Steel <i>Ex. A-2, A-6, D-2, M-2</i>	300 - 600	.002 - .004	
Stainless Steel <i>Ex. 304, 316, 420, 15-5PH, 17-4PH</i>	200 - 400	.002 - .004	
Iron <i>Ex. Cast, Ductile, Nodular</i>	400 - 700	.002 - .004	
Nickel & Titanium Alloy <i>Ex. Inconel, Hastelloy, Ti-6AL-4V</i>	120 - 250	.0012 - .0022	
Non-Ferrous Metal <i>Ex. Aluminum, Bronze, Brass</i>	1000 - 2000	.003 - .008	

Flat Bottom Drills

Available Modifications

- Modified Diameters
 - Reduce Shank Diameters
 - Shift Center Insert to Remove Center Nib
- 2 - 3 Day Delivery



Note: To Maintain Correct Drill Diameter in Lathe Applications Indicate Drill to Spindle Center

Applications

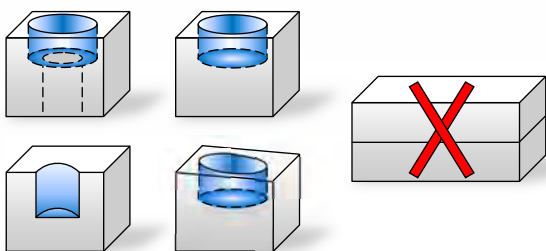

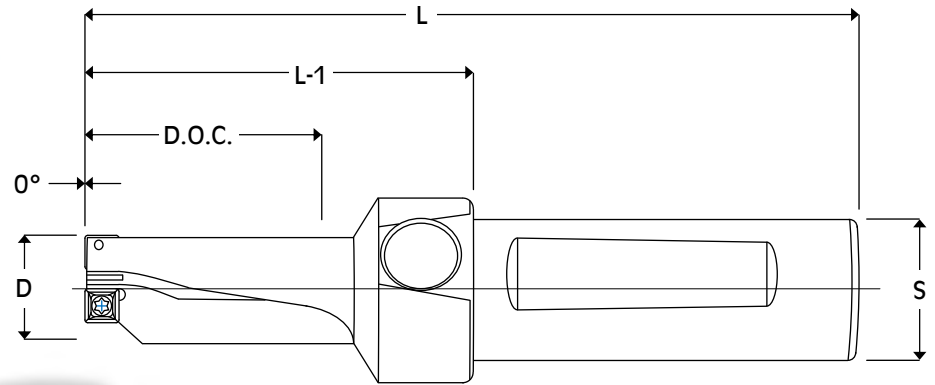

Coolant Thru Standard

Tool Info.

Tool #	D	Flutes	L	L-1	D.O.C.	S	Coolant Plug	Insert
FB-500	.500	2-1 Effective	4.000	2.000	1.125	.750	NPT 1/8	SPEB-1511CB
FB-500-3	.500	2-1 Effective	4.500	2.500	1.500			
FB-531	.531	2-1 Effective	4.000	2.000	1.125			
FB-531-3	.531	2-1 Effective	4.500	2.500	1.593			
FB-562	.562	2-1 Effective	4.000	2.000	1.125			
FB-562-3	.562	2-1 Effective	4.625	2.625	1.687			
FB-593	.593	2-1 Effective	4.000	2.000	1.187			
FB-593-3	.593	2-1 Effective	4.687	2.687	1.812			
FB-625	.625	2-1 Effective	4.250	2.250	1.375			
FB-625-3	.625	2-1 Effective	4.750	2.750	1.875			
FB-656	.656	2-1 Effective	4.250	2.250	1.375			
FB-656-3	.656	2-1 Effective	4.875	2.875	2.000			

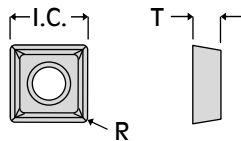

Insert Info

SPEB-1511CB	
Grades	X33 X40
I.C.	.187
T	.082
R	.015
Screw	164T
Wrench	T-6

Speed and Feed Info.

Material	S.F.M.	I.P.R.
Mild & Low Carbon Steel Ex. 1018, 1020, 1117, 1141, 12L14	800 - 1200	.001 - .003
High Carbon & Alloy Steel Ex. 1045, 4140, 4340, 52100, 8620	500 - 800	.001 - .003
Lower Carbon Tool Steel Ex. P-20, H-13, S-7	400 - 700	.001 - .003
Tool Steel Ex. A-2, A-6, D-2, M-2	300 - 600	.001 - .003
Stainless Steel Ex. 304, 316, 420, 15-5PH, 17-4PH	300 - 600	.001 - .003
Iron Ex. Cast, Ductile, Nodular	600 - 1000	.002 - .003
Nickel & Titanium Alloy Ex. Inconel, Hastelloy, Ti-6AL-4V	120 - 180	.001 - .0015
Non-Ferrous Metal Ex. Aluminum, Bronze, Brass	1000 - 2500	.002 - .003

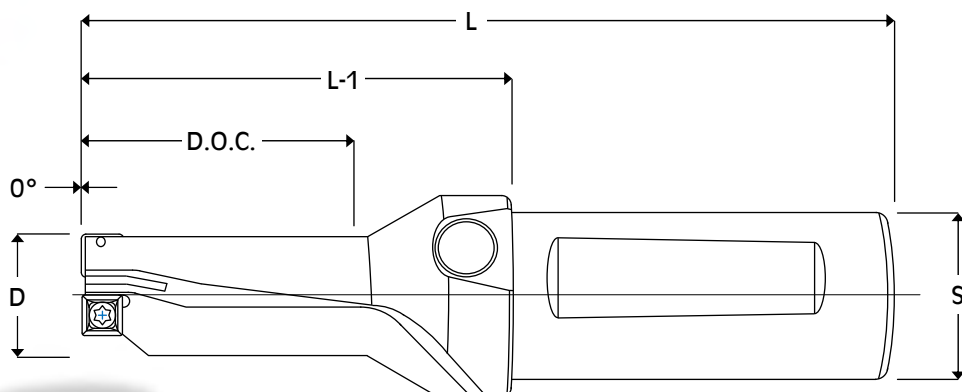

Coolant Thru Standard

Tool Info.

Tool #	D	Flutes	L	L-1	D.O.C.	S	Coolant Plug	Insert
FB-687	.687	2-1 Effective	4.250	2.250	1.375	.750	NPT 1/8	SPEB-221CB
FB-687-3	.687	2-1 Effective	4.937	2.937	2.062			
FB-718	.718	2-1 Effective	4.250	2.250	1.437			
FB-718-3	.718	2-1 Effective	5.062	3.062	2.187			
FB-750	.750	2-1 Effective	4.750	2.500	1.500	1.000		
FB-750-3	.750	2-1 Effective	5.500	3.250	2.250			
FB-781	.781	2-1 Effective	4.750	2.500	1.562			
FB-781-3	.781	2-1 Effective	5.500	3.250	2.343			
FB-812	.812	2-1 Effective	4.750	2.500	1.625			
FB-812-3	.812	2-1 Effective	5.625	3.375	2.437			

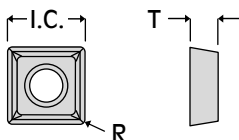

Insert Info

SPEB-221CB	
Grades	X33 X40
I.C.	.250
T	.125
R	.015
Screw	314T
Wrench	T-8

Speed and Feed Info.

Material	S.F.M.	I.P.R.
Mild & Low Carbon Steel Ex. 1018, 1020, 1117, 1141, 12L14	800 - 1200	.002 - .004
High Carbon & Alloy Steel Ex. 1045, 4140, 4340, 52100, 8620	500 - 800	.002 - .003
Lower Carbon Tool Steel Ex. P-20, H-13, S-7	400 - 700	.002 - .003
Tool Steel Ex. A-2, A-6, D-2, M-2	300 - 600	.001 - .003
Stainless Steel Ex. 304, 316, 420, 15-5PH, 17-4PH	300 - 600	.001 - .003
Iron Ex. Cast, Ductile, Nodular	600 - 1000	.002 - .005
Nickel & Titanium Alloy Ex. Inconel, Hastelloy, Ti-6AL-4V	120 - 180	.001 - .002
Non-Ferrous Metal Ex. Aluminum, Bronze, Brass	1000 - 2500	.003 - .006

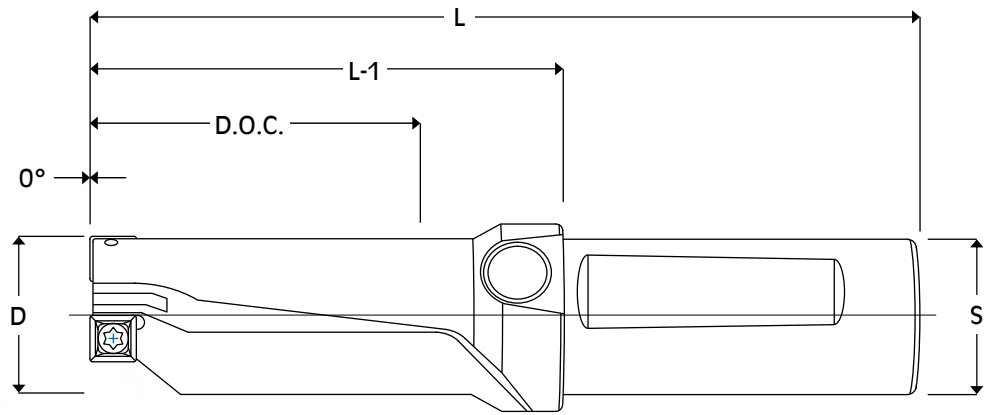

Coolant Thru Standard

Tool Info.

Tool #	D	Flutes	L	L-1	D.O.C.	S	Coolant Plug	Insert
FB-875	.875	2-1 Effective	5.000	2.750	1.750	1.000	NPT 1/8	SPEB-2522CB
FB-875-3	.875	2-1 Effective	5.750	3.500	2.625			
FB-937	.937	2-1 Effective	5.000	2.750	1.875			
FB-937-3	.937	2-1 Effective	6.000	3.750	2.812			
FB-984	.984	2-1 Effective	5.250	3.000	2.000			
FB-984-3	.984	2-1 Effective	6.125	3.875	2.950			
FB-1000	1.000	2-1 Effective	5.250	3.000	2.000			
FB-1000-3	1.000	2-1 Effective	6.250	4.000	3.000			
FB-1062	1.062	2-1 Effective	5.250	3.000	2.125			
FB-1062-3	1.062	2-1 Effective	6.250	4.000	3.187			
FB-1125	1.125	2-1 Effective	5.250	3.000	2.250			
FB-1125-3	1.125	2-1 Effective	6.375	4.125	3.375			

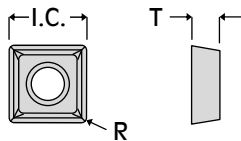

Insert Info

SPEB-2522CB	
Grades	X33 X40
I.C.	.312
T	.125
R	.031
Screw	314T
Wrench	T-8

Speed and Feed Info.

Material	S.F.M.	I.P.R.
Mild & Low Carbon Steel Ex. 1018, 1020, 1117, 1141, 12L14	800 - 1200	.002 - .004
High Carbon & Alloy Steel Ex. 1045, 4140, 4340, 52100, 8620	500 - 800	.002 - .003
Lower Carbon Tool Steel Ex. P-20, H-13, S-7	400 - 700	.002 - .003
Tool Steel Ex. A-2, A-6, D-2, M-2	300 - 600	.001 - .003
Stainless Steel Ex. 304, 316, 420, 15-5PH, 17-4PH	300 - 600	.001 - .003
Iron Ex. Cast, Ductile, Nodular	600 - 1000	.002 - .005
Nickel & Titanium Alloy Ex. Inconel, Hastelloy, Ti-6AL-4V	120 - 180	.001 - .002
Non-Ferrous Metal Ex. Aluminum, Bronze, Brass	1000 - 2500	.003 - .006

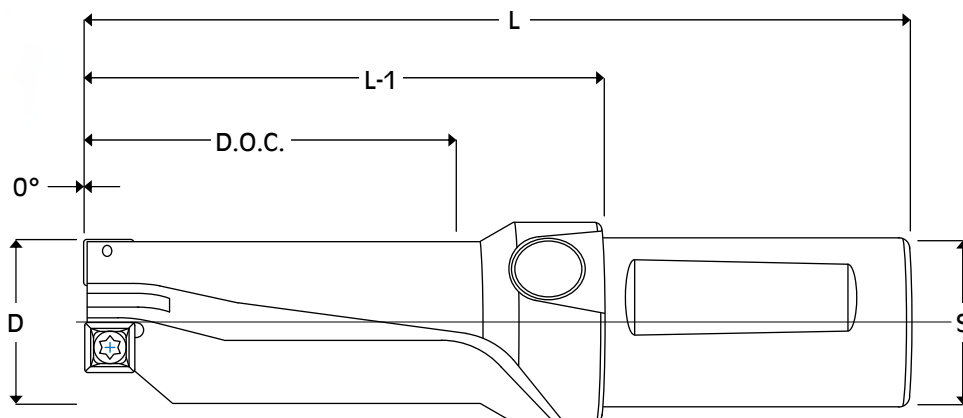

Coolant Thru Standard

Tool Info.

Tool #	D	Flutes	L	L-1	D.O.C.	S	Coolant Plug	Insert
FB-1187	1.187	2-1 Effective	6.000	3.750	2.375	1.250	NPT 1/4	SPEB-332CB
FB-1187-3	1.187	2-1 Effective	7.125	4.875	3.562			
FB-1250	1.250	2-1 Effective	6.000	3.750	2.500			
FB-1250-3	1.250	2-1 Effective	7.500	5.250	3.750			
FB-1312	1.312	2-1 Effective	6.000	3.750	2.625			
FB-1312-3	1.312	2-1 Effective	7.562	5.312	3.937			
FB-1375	1.375	2-1 Effective	6.000	3.750	2.750			
FB-1375-3	1.375	2-1 Effective	7.625	5.375	4.125			

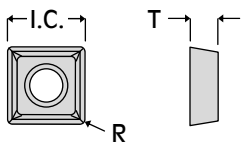

Insert Info

SPEB-332CB	
Grades	X33 X40
I.C.	.375
T	.187
R	.031
Screw	538T
Wrench	T-10

Speed and Feed Info.

Material	S.F.M.	I.P.R.
Mild & Low Carbon Steel Ex. 1018, 1020, 1117, 1141, 12L14	800 - 1200	.003 - .005
High Carbon & Alloy Steel Ex. 1045, 4140, 4340, 52100, 8620	500 - 800	.003 - .005
Lower Carbon Tool Steel Ex. P-20, H-13, S-7	400 - 700	.003 - .005
Tool Steel Ex. A-2, A-6, D-2, M-2	300 - 600	.002 - .004
Stainless Steel Ex. 304, 316, 420, 15-5PH, 17-4PH	300 - 600	.002 - .004
Iron Ex. Cast, Ductile, Nodular	600 - 1000	.003 - .006
Nickel & Titanium Alloy Ex. Inconel, Hastelloy, Ti-6AL-4V	120 - 180	.002 - .003
Non-Ferrous Metal Ex. Aluminum, Bronze, Brass	1000 - 2500	.004 - .008

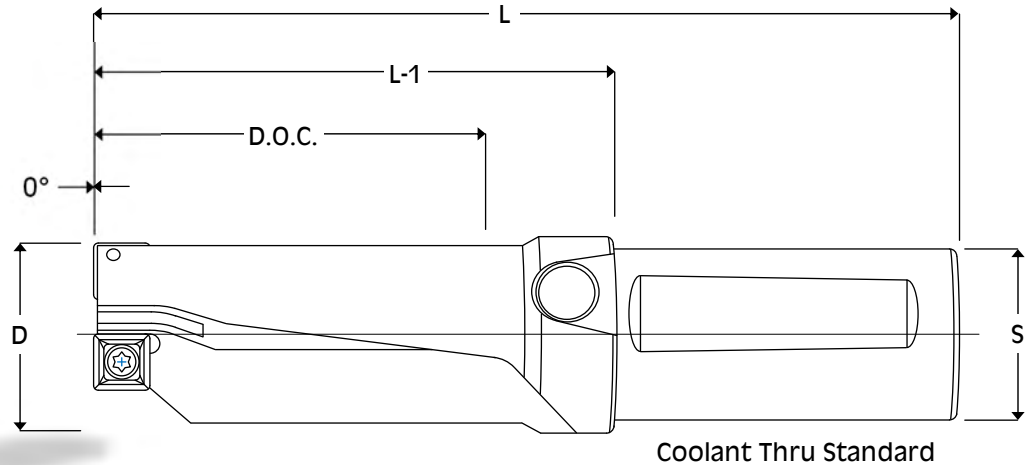

Tool Info.

Tool #	D	Flutes	L	L-1	D.O.C.	S	Coolant Plug	Insert
FB-1437	1.437	2-1 Effective	6.250	4.000	2.875	1.250	NPT 1/4	SPEB-432CB
FB-1437-3	1.437	2-1 Effective	7.687	5.437	4.312			
FB-1500	1.500	2-1 Effective	6.250	4.000	3.000			
FB-1500-3	1.500	2-1 Effective	7.750	5.500	4.500	1.500		
FB-1562	1.562	2-1 Effective	7.500	4.500	3.125			
FB-1562-3	1.562	2-1 Effective	9.062	6.062	4.687			
FB-1625	1.625	2-1 Effective	7.500	4.500	3.250	1.500		
FB-1625-3	1.625	2-1 Effective	9.125	6.125	4.875			
FB-1687	1.687	2-1 Effective	7.500	4.500	3.375			
FB-1687-3	1.687	2-1 Effective	9.312	6.312	5.061	1.500		
FB-1750	1.750	2-1 Effective	7.750	4.750	3.500			
FB-1750-3	1.750	2-1 Effective	9.625	6.625	5.250			

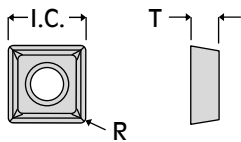

Insert Info

SPEB-432CB	
Grades	X33 X40
I.C.	.500
T	.187
R	.031
Screw	638T
Wrench	T-15

Speed and Feed Info.

Material	S.F.M.	I.P.R.
Mild & Low Carbon Steel Ex. 1018, 1020, 1117, 1141, 12L14	800 - 1200	.003 - .005
High Carbon & Alloy Steel Ex. 1045, 4140, 4340, 52100, 8620	500 - 800	.003 - .005
Lower Carbon Tool Steel Ex. P-20, H-13, S-7	400 - 700	.003 - .005
Tool Steel Ex. A-2, A-6, D-2, M-2	300 - 600	.002 - .004
Stainless Steel Ex. 304, 316, 420, 15-5PH, 17-4PH	300 - 600	.002 - .004
Iron Ex. Cast, Ductile, Nodular	600 - 1000	.003 - .006
Nickel & Titanium Alloy Ex. Inconel, Hastelloy, Ti-6AL-4V	120 - 180	.002 - .003
Non-Ferrous Metal Ex. Aluminum, Bronze, Brass	1000 - 2500	.004 - .008

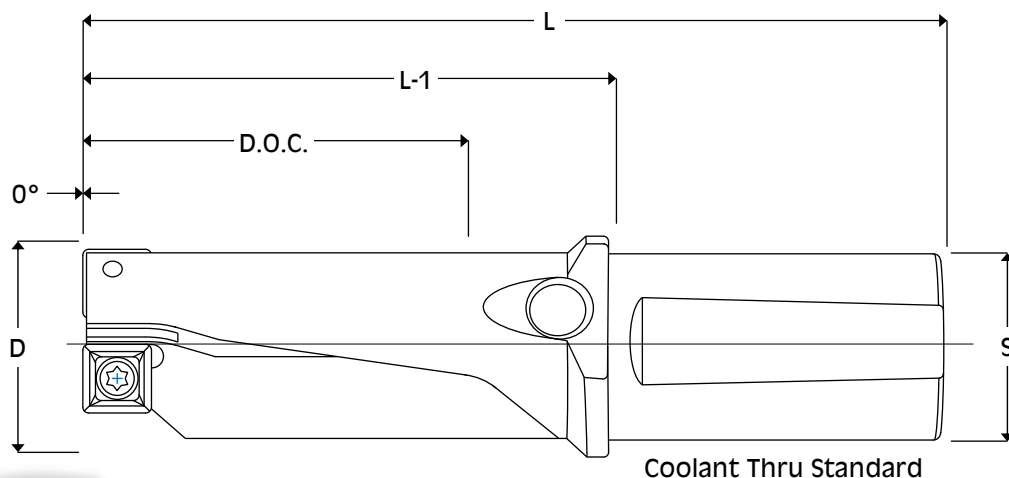

Tool Info.

Tool #	D	Flutes	L	L-1	D.O.C.	S	Coolant Plug	Insert
FB-1875	1.875	2-1 Effective	8.000	5.000	3.750	1.500	NPT 1/4	SPEB-532CB
FB-1875-3	1.875	2-1 Effective	9.875	6.875	5.625			
FB-2000	2.000	2-1 Effective	8.125	5.125	4.000	1.500	NPT 3/8	SPEB-6352CB
FB-2000-3	2.000	2-1 Effective	10.125	7.125	6.000			
FB-2125	2.125	2-1 Effective	9.125	5.625	4.500	2.000	NPT 3/8	SPEB-6352CB
FB-2250	2.250	2-1 Effective	9.125	5.625	4.500			
FB-2250-3	2.250	2-1 Effective	12.125	8.625	6.750			
FB-2375	2.375	2-1 Effective	9.625	6.125	5.000			
FB-2500	2.500	2-1 Effective	9.625	6.125	5.000			
FB-2500-3	2.500	2-1 Effective	12.875	9.375	7.500			

Insert Info	
SPEB-532CB	
Grade	X33
I.C.	.625
T	.187
R	.031
Screw	838T
Wrench	T-20

Insert Info	
SPEB-6352CB	
Grades	X33 X40
I.C.	.750
T	.220
R	.031
Screw	1012T
Wrench	T-25

Speed and Feed Info.

Material	S.F.M.	I.P.R.
Mild & Low Carbon Steel Ex. 1018, 1020, 1117, 1141, 12L14	800 - 1200	.003 - .005
High Carbon & Alloy Steel Ex. 1045, 4140, 4340, 52100, 8620	500 - 800	.003 - .005
Lower Carbon Tool Steel Ex. P-20, H-13, S-7	400 - 700	.003 - .005
Tool Steel Ex. A-2, A-6, D-2, M-2	300 - 600	.002 - .004
Stainless Steel Ex. 304, 316, 420, 15-5PH, 17-4PH	300 - 600	.002 - .004
Iron Ex. Cast, Ductile, Nodular	600 - 1000	.003 - .006
Nickel & Titanium Alloy Ex. Inconel, Hastelloy, Ti-6AL-4V	120 - 180	.002 - .003
Non-Ferrous Metal Ex. Aluminum, Bronze, Brass	1000 - 2500	.004 - .008

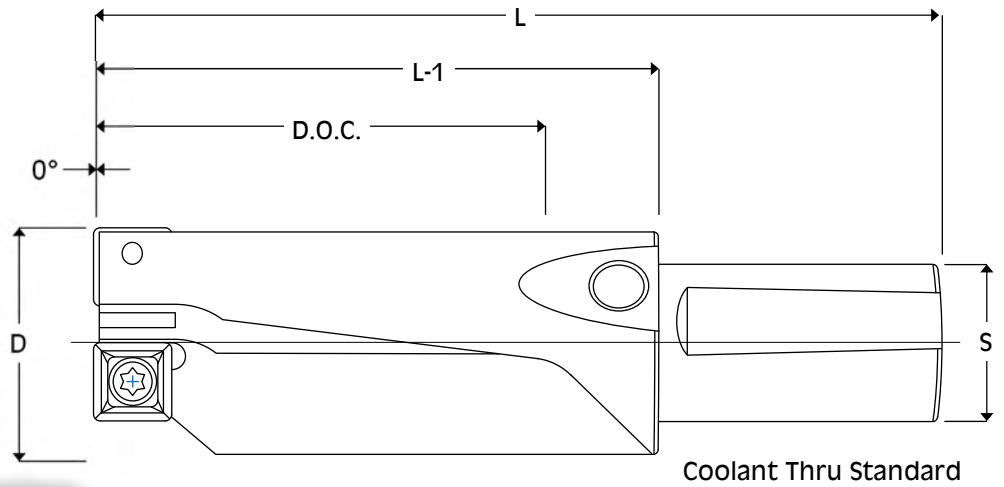

Tool Info.

Tool #	D	Flutes	L	L-1	D.O.C.	S	Coolant Plug	Insert
FB-2750	2.750	2-1 Effective	10.125	6.625	5.500	2.000	NPT 3/8	SPEB-842CB
FB-3000	3.000	2-1 Effective	10.625	7.125	6.000			
FB-3500	3.500	2-1 Effective	11.625	8.125	7.000			

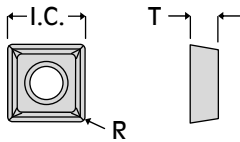

Insert Info

SPEB-842CB	
Grade	X33
I.C.	1.000
T	.250
R	.031
Screw	1412T
Wrench	T-532

Speed and Feed Info.

Material	S.F.M.	I.P.R.
Mild & Low Carbon Steel Ex. 1018, 1020, 1117, 1141, 12L14	800 - 1200	.003 - .005
High Carbon & Alloy Steel Ex. 1045, 4140, 4340, 52100, 8620	500 - 800	.003 - .005
Lower Carbon Tool Steel Ex. P-20, H-13, S-7	400 - 700	.003 - .005
Tool Steel Ex. A-2, A-6, D-2, M-2	300 - 600	.002 - .004
Stainless Steel Ex. 304, 316, 420, 15-5PH, 17-4PH	300 - 600	.002 - .004
Iron Ex. Cast, Ductile, Nodular	600 - 1000	.003 - .006
Nickel & Titanium Alloy Ex. Inconel, Hastelloy, Ti-6AL-4V	120 - 180	.002 - .003
Non-Ferrous Metal Ex. Aluminum, Bronze, Brass	1000 - 2500	.004 - .008

Drill Sergeants

Insert Loading Procedure

- Air Blast Pocket Clean
- Hold Insert in place
- Tighten screws until each one makes light contact
- Alternate tightening screws several times until screws are tight

Patented
(Patent # 5,259,707)

Coolant Thru Standard

Special Sizes Available
Upon Request

Available in 2:1, 4:1 & 6:1 Ratios

Available in Straight Flute for
Lathe & High Pressure Coolant
Applications

-Helical Flute Shown-

Rear Coolant Ports

Applications

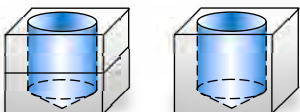

(Patent # 5,259,707)

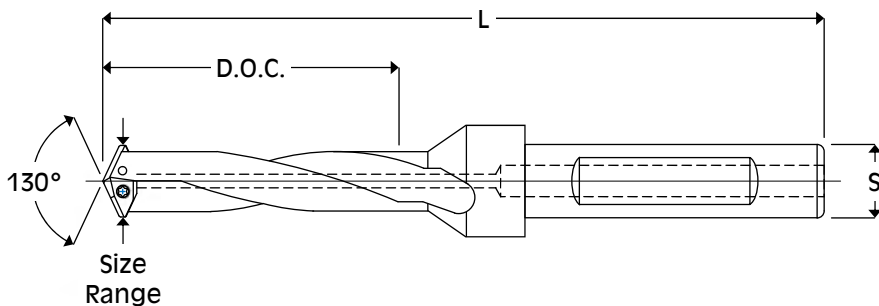

Standard Tap Sizes Highlighted in Red

<i>Helical Flute</i>		<i>Tool Info.</i>					
Tool #	Size Range	Standard Inserts	Grade	L	D.O.C.	Coolant Plug	S
DS-39-45S	.396 - .450	DI-406 / DI-421 / DI-437	X33	3.812	1.000	NPT 1/8	.500
DS-39-45L				4.812	2.000	N/A	
DS-45-51S	.451 - .510	DI-468 / DI-500		3.812	1.000	NPT 1/8	
DS-45-51L				4.812	2.000	N/A	

<i>Straight Flute</i>		<i>Tool Info.</i>					
Tool #	Size Range	Standard Inserts	Grade	L	D.O.C.	Coolant Plug	S
DSL-39-45L	.396 - .450	DI-406 / DI-421 / DI-437	X33	4.812	2.000	NPT 1/8	.500
DSL-45-51L	.451 - .510	DI-468 / DI-500					

Use Straight Flute For Lathe and High Pressure Coolant Applications over 500 P.S.I.

<p>Diameter Tolerance +/- .002</p>			
<i>Insert Info</i>			
Insert #	D	Screw	Wrench
DI-406	.4062	164T	T-6
DI-421	.4219		
DI-437	.4375		
DI-468	.4688		
DI-500	.5000		

<i>Speed and Feed Info.</i>		
Material	S.F.M.	I.P.R.
Mild & Low Carbon Steel Ex. 1018, 1020, 1117, 1141, 12L14	700 - 900	.003 - .005
High Carbon & Alloy Steel Ex. 1045, 4140, 4340, 52100, 8620	500 - 600	.003 - .005
Lower Carbon Tool Steel Ex. P-20, H-13, S-7	400 - 500	.003 - .005
Tool Steel Ex. A-2, A-6, D-2, M-2	350 - 450	.003 - .005
Stainless Steel Ex. 304, 316, 420, 15-5PH, 17-4PH	350 - 550	.003 - .005
Iron Ex. Cast, Ductile, Nodular	600 - 800	.004 - .006
Nickel & Titanium Alloy Ex. Inconel, Hastelloy, Ti-6AL-4V	100 - 200	.001 - .003
Non-Ferrous Metal Ex. Aluminum, Bronze, Brass	1000 - 2000	.004 - .006

(Patent # 5,259,707)

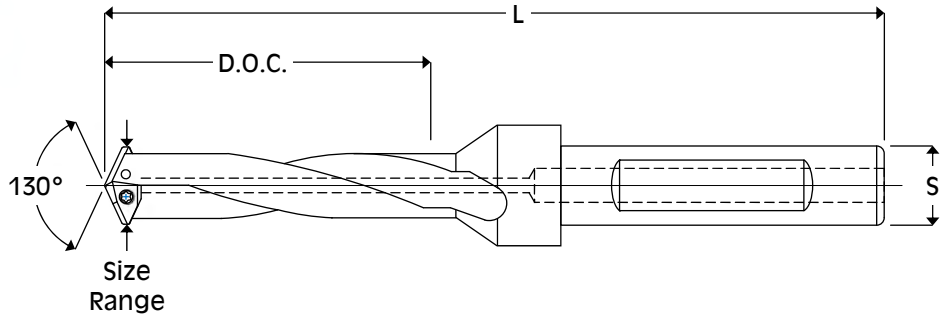

Standard Tap Sizes Highlighted in Red

<i>Helical Flute</i>		<i>Tool Info.</i>					
Tool #	Size Range	Standard Inserts	Grade	L	D.O.C.	Coolant Plug	S
DS-51-57S	.511 - .570	DI-515 / DI-531 / DI-562	X33	5.000	1.500	NPT 1/8	.750
DS-51-57L				6.500	3.000	N/A	
DS-57-63S	.571 - .630	DI-578 / DI-593 / DI-625		5.000	1.500	NPT 1/8	
DS-57-63L				6.500	3.000	N/A	
DS-63-69S	.631 - .695	DI-640 / DI-656 / DI-669 / DI-687		5.000	1.500	NPT 1/8	
DS-63-69L				6.500	3.000	N/A	

<i>Straight Flute</i>		<i>Tool Info.</i>					
Tool #	Size Range	Standard Inserts	Grade	L	D.O.C.	Coolant Plug	S
DSL-51-57L	.511 - .570	DI-515 / DI-531 / DI-562	X33	6.500	3.000	NPT 1/8	.750
DSL-57-63L	.571 - .630	DI-578 / DI-593 / DI-625					
DSL-63-69L	.631 - .695	DI-640 / DI-656 / DI-669 / DI-687					

Use Straight Flute For Lathe and High Pressure Coolant Applications over 500 P.S.I.

<p>Diameter Tolerance +/- .002</p>			
<i>Insert Info</i>			
Insert #	D	Screw	Wrench
DI-515	.5156	314T	T-8
DI-531	.5312		
DI-562	.5625		
DI-578	.5781		
DI-593	.5938		
DI-625	.6250		
DI-640	.6400		
DI-656	.6562		
DI-669	.6693		
DI-687	.6875		

<i>Speed and Feed Info.</i>		
Material	S.F.M.	I.P.R.
Mild & Low Carbon Steel Ex. 1018, 1020, 1117, 1141, 12L14	700 - 900	.004 - .006
High Carbon & Alloy Steel Ex. 1045, 4140, 4340, 52100, 8620	500 - 600	.004 - .006
Lower Carbon Tool Steel Ex. P-20, H-13, S-7	400 - 500	.004 - .006
Tool Steel Ex. A-2, A-6, D-2, M-2	350 - 450	.004 - .006
Stainless Steel Ex. 304, 316, 420, 15-5PH, 17-4PH	350 - 550	.004 - .006
Iron Ex. Cast, Ductile, Nodular	600 - 800	.005 - .008
Nickel & Titanium Alloy Ex. Inconel, Hastelloy, TI-6AL-4V	100 - 200	.001 - .003
Non-Ferrous Metal Ex. Aluminum, Bronze, Brass	1000 - 2000	.005 - .008

(Patent # 5,259,707)

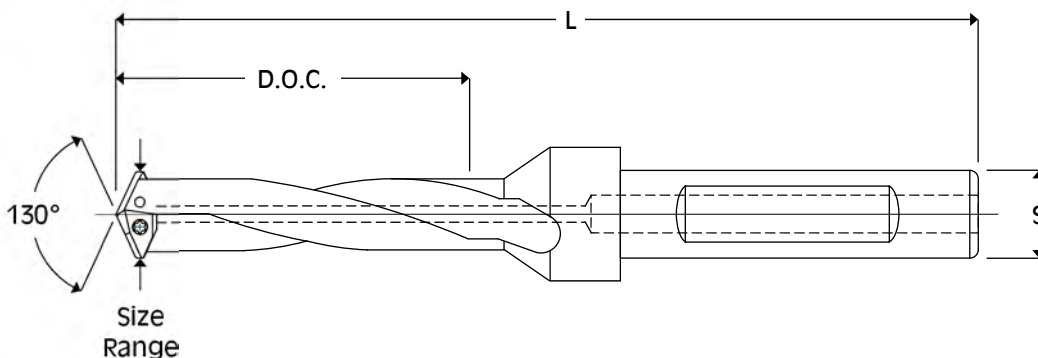

<i>Helical Flute</i>		<i>Tool Info.</i>					
Tool #	Size Range	Standard Inserts	Grade	L	D.O.C.	Coolant Plug	S
DS-69-76S	.696 - .760	DI-718 / DI-750	X33	5.000	1.500	NPT 1/8	.750
DS-69-76L				6.500	3.000	N/A	
DS-69-76XL				8.000	4.500	N/A	

<i>Straight Flute</i>		<i>Tool Info.</i>					
Tool #	Size Range	Standard Inserts	Grade	L	D.O.C.	Coolant Plug	S
DSL-69-76L	.696 - .760	DI-718 / DI-750	X33	6.500	3.000	NPT 1/8	.750
DSL-69-76XL				8.000	4.500		

Use Straight Flute For Lathe and High Pressure Coolant Applications over 500 P.S.I.

<p>Diameter Tolerance +/- .002</p>			
<i>Insert Info</i>			
Insert #	D	Screw	Wrench
DI-718	.7188	314T	T-8
DI-750	.7500		

<i>Speed and Feed Info.</i>		
Material	S.F.M.	I.P.R.
Mild & Low Carbon Steel Ex. 1018, 1020, 1117, 1141, 12L14	700 - 900	.004 - .006
High Carbon & Alloy Steel Ex. 1045, 4140, 4340, 52100, 8620	500 - 600	.004 - .006
Lower Carbon Tool Steel Ex. P-20, H-13, S-7	400 - 500	.004 - .006
Tool Steel Ex. A-2, A-6, D-2, M-2	350 - 450	.004 - .006
Stainless Steel Ex. 304, 316, 420, 15-5PH, 17-4PH	350 - 550	.004 - .006
Iron Ex. Cast, Ductile, Nodular	600 - 800	.005 - .008
Nickel & Titanium Alloy Ex. Inconel, Hastelloy, Ti-6AL-4V	100 - 200	.001 - .003
Non-Ferrous Metal Ex. Aluminum, Bronze, Brass	1000 - 2000	.005 - .008

(Patent # 5,259,707)

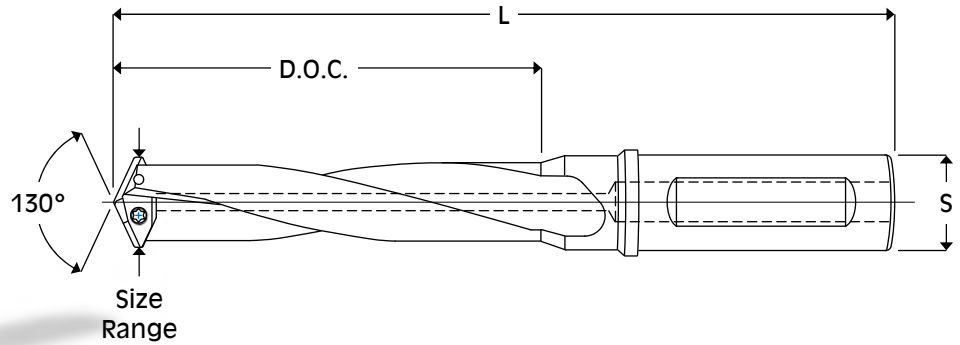

Standard Tap Sizes Highlighted in Red

Helical Flute		Tool Info.					
Tool #	Size Range	Standard Inserts	Grade	L	D.O.C.	Coolant Plug	S
DS-76-84S	.761 - .840	DI-765 / DI-781 / DI-812	X33	5.950	2.000	NPT 1/8	1.000
DS-76-84L				7.950	4.000	N/A	
DS-76-84XL				9.950	6.000	N/A	
DS-84-92S	.841 - .925	DI-843 / DI-875 / DI-906 / DI-921		5.950	2.000	NPT 1/8	
DS-84-92L				7.950	4.000	N/A	
DS-84-92XL				9.950	6.000	N/A	

Straight Flute		Tool Info.					
Tool #	Size Range	Standard Inserts	Grade	L	D.O.C.	Coolant Plug	S
DSL-76-84L	.761 - .840	DI-765 / DI-781 / DI-812	X33	7.950	4.000	NPT 1/8	1.000
DSL-76-84XL				9.950	6.000		
DSL-84-92L	.841 - .925	DI-843 / DI-875 / DI-906 / DI-921		7.950	4.000		
DSL-84-92XL				9.950	6.000		

Use Straight Flute For Lathe and High Pressure Coolant Applications over 500 P.S.I.

<p>Diameter Tolerance +/- .002</p>			
Insert Info			
Insert #	D	Screw	Wrench
DI-765	.7656	560T	T-10
DI-781	.7812		
DI-812	.8125		
DI-843	.8438		
DI-875	.8750		
DI-906	.9062		
DI-921	.9219		

Speed and Feed Info.		
Material	S.F.M.	I.P.R.
Mild & Low Carbon Steel Ex. 1018, 1020, 1117, 1141, 12L14	700 - 900	.005 - .008
High Carbon & Alloy Steel Ex. 1045, 4140, 4340, 52100, 8620	500 - 600	.005 - .008
Lower Carbon Tool Steel Ex. P-20, H-13, S-7	400 - 500	.005 - .008
Tool Steel Ex. A-2, A-6, D-2, M-2	350 - 450	.005 - .008
Stainless Steel Ex. 304, 316, 420, 15-5PH, 17-4PH	350 - 550	.005 - .008
Iron Ex. Cast, Ductile, Nodular	600 - 800	.006 - .012
Nickel & Titanium Alloy Ex. Inconel, Hastelloy, Ti-6AL-4V	100 - 200	.002 - .004
Non-Ferrous Metal Ex. Aluminum, Bronze, Brass	1000 - 2000	.006 - .012

(Patent # 5,259,707)

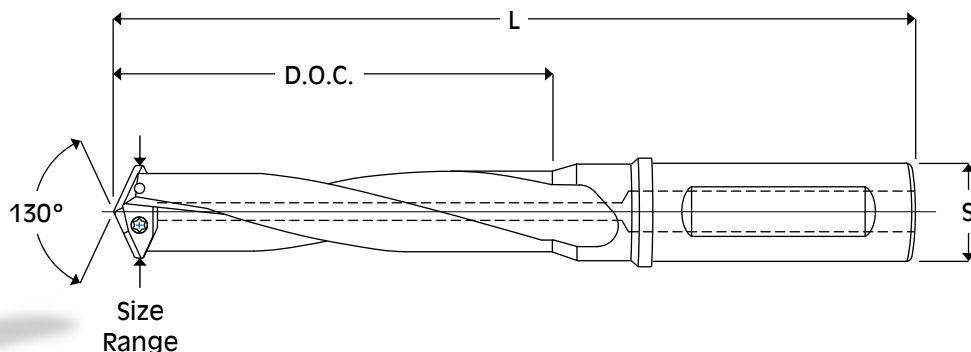

Standard Tap Sizes Highlighted in Red

<i>Helical Flute</i>		<i>Tool Info.</i>					
Tool #	Size Range	Standard Inserts	Grade	L	D.O.C.	Coolant Plug	S
DS-92-101S	.926 - 1.010	DI-937 / DI-968 / DI-984 / DI-1000	X33	5.950	2.000	NPT 1/8	1.000
DS-92-101L				7.950	4.000	N/A	
DS-92-101XL				9.950	6.000	N/A	

<i>Straight Flute</i>		<i>Tool Info.</i>					
Tool #	Size Range	Standard Inserts	Grade	L	D.O.C.	Coolant Plug	S
DSL-92-101L	.926 - 1.010	DI-937 / DI-968 / DI-984 / DI-1000	X33	7.950	4.000	NPT 1/8	1.000
DSL-92-101L				9.950	6.000		

Use Straight Flute For Lathe and High Pressure Coolant Applications over 500 P.S.I.

<p>Diameter Tolerance +/- .002</p>			
<i>Insert Info</i>			
Insert #	D	Screw	Wrench
DI-937	.9375	560T	T-10
DI-968	.9688		
DI-984	.9840		
DI-1000	1.000		

<i>Speed and Feed Info.</i>		
Material	S.F.M.	I.P.R.
Mild & Low Carbon Steel Ex. 1018, 1020, 1117, 1141, 12L14	700 - 900	.005 - .008
High Carbon & Alloy Steel Ex. 1045, 4140, 4340, 52100, 8620	500 - 600	.005 - .008
Lower Carbon Tool Steel Ex. P-20, H-13, S-7	400 - 500	.005 - .008
Tool Steel Ex. A-2, A-6, D-2, M-2	350 - 450	.005 - .008
Stainless Steel Ex. 304, 316, 420, 15-5PH, 17-4PH	350 - 550	.005 - .008
Iron Ex. Cast, Ductile, Nodular	600 - 800	.006 - .012
Nickel & Titanium Alloy Ex. Inconel, Hastelloy, Ti-6AL-4V	100 - 200	.002 - .004
Non-Ferrous Metal Ex. Aluminum, Bronze, Brass	1000 - 2000	.006 - .012

Drill Sergeants

1.011 - 1.260 Diameter

(Patent # 5,259,707)

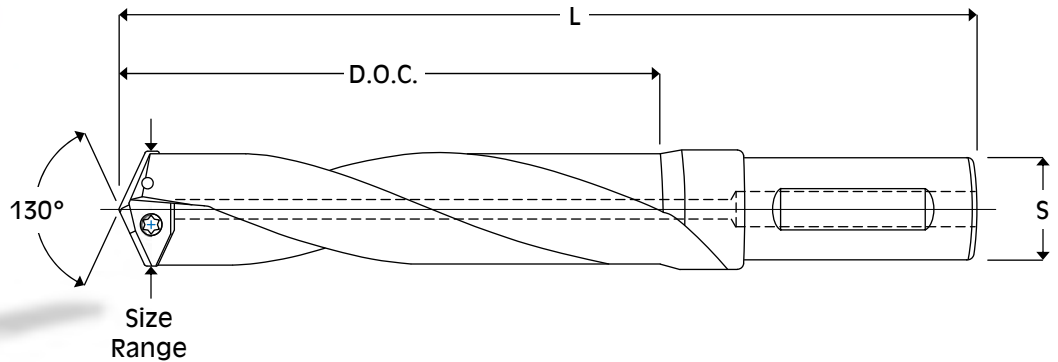

Standard Tap Sizes Highlighted in Red

Helical Flute		Tool Info.					
Tool #	Size Range	Standard Inserts	Grade	L	D.O.C.	Coolant Plug	S
DS-101-113S	1.011 - 1.135	DI-1031 / DI-1062 / DI-1093 / DI-1125	X33	6.500	2.500	NPT 1/4	1.000
DS-101-113L				9.000	5.000	N/A	
DS-101-113XL				11.500	7.500	N/A	
DS-113-126S	1.136 - 1.260	DI-1156 / DI-1187 / DI-1218 / DI-1250		6.500	2.500	NPT 1/4	
DS-113-126L				9.000	5.000	N/A	
DS-113-126XL				11.500	7.500	N/A	

Straight Flute		Tool Info.					
Tool #	Size Range	Standard Inserts	Grade	L	D.O.C.	Coolant Plug	S
DSL-101-113L	1.011 - 1.135	DI-1031 / DI-1062 / DI-1093 / DI-1125	X33	9.000	5.000	NPT 1/4	1.000
DSL-101-113XL				11.500	7.500		
DSL-113-126L	1.136 - 1.260	DI-1156 / DI-1187 / DI-1218 / DI-1250		9.000	5.000		
DSL-113-126XL				11.500	7.500		

Use Straight Flute For Lathe and High Pressure Coolant Applications over 500 P.S.I.

<p>Diameter Tolerance +/- .002</p>			
Insert Info			
Insert #	D	Screw	Wrench
DI-1031	1.0312	638T	T-15
DI-1062	1.0625		
DI-1093	1.0938		
DI-1125	1.1250		
DI-1156	1.1562		
DI-1187	1.1875		
DI-1218	1.2188		
DI-1250	1.2500		

Speed and Feed Info.		
Material	S.F.M.	I.P.R.
Mild & Low Carbon Steel Ex. 1018, 1020, 1117, 1141, 12L14	700 - 900	.006 - .010
High Carbon & Alloy Steel Ex. 1045, 4140, 4340, 52100, 8620	500 - 600	.006 - .010
Lower Carbon Tool Steel Ex. P-20, H-13, S-7	400 - 500	.006 - .010
Tool Steel Ex. A-2, A-6, D-2, M-2	350 - 450	.006 - .010
Stainless Steel Ex. 304, 316, 420, 15-5PH, 17-4PH	350 - 550	.005 - .008
Iron Ex. Cast, Ductile, Nodular	600 - 800	.008 - .014
Nickel & Titanium Alloy Ex. Inconel, Hastelloy, Ti-6AL-4V	100 - 200	.003 - .005
Non-Ferrous Metal Ex. Aluminum, Bronze, Brass	1000 - 2000	.008 - .014

(Patent # 5,259,707)

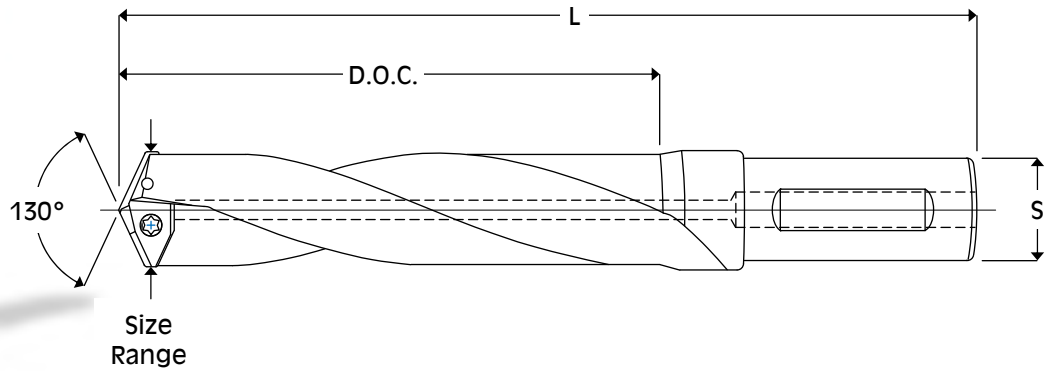

Standard Tap Sizes Highlighted in Red

Helical Flute		Tool Info.					
Tool #	Size Range	Standard Inserts	Grade	L	D.O.C.	Coolant Plug	S
DS-126-138S	1.261 - 1.385	DI-1281 / DI-1312 / DI-1343 / DI-1375	X33	7.250	3.000	NPT 1/4	1.250
DS-126-138L				10.250	6.000	N/A	
DS-126-138XL				13.250	9.000	N/A	
DS-138-151S	1.386 - 1.510	DI-1406 / DI-1437 / DI-1468 / DI-1500		7.250	3.000	NPT 1/4	
DS-138-151L				10.250	6.000	N/A	
DS-138-151XL				13.250	9.000	N/A	

Straight Flute		Tool Info.					
Tool #	Size Range	Standard Inserts	Grade	L	D.O.C.	Coolant Plug	S
DSL-126-138L	1.261 - 1.385	DI-1281 / DI-1312 / DI-1343 / DI-1375	X33	10.250	6.000	NPT 1/4	1.250
DSL-126-138XL				13.250	9.000		
DSL-138-151L	1.386 - 1.510	DI-1406 / DI-1437 / DI-1468 / DI-1500		10.250	6.000		
DSL-138-151XL				13.250	9.000		

Use Straight Flute For Lathe and High Pressure Coolant Applications over 500 P.S.I.

<p>Diameter Tolerance +/- .002</p>			
Insert Info			
Insert #	D	Screw	Wrench
DI-1281	1.2812	638T	T-15
DI-1312	1.3125		
DI-1343	1.3438		
DI-1375	1.3750		
DI-1406	1.4062		
DI-1437	1.4375		
DI-1468	1.4688		
DI-1500	1.5000		

Speed and Feed Info.		
Material	S.F.M.	I.P.R.
Mild & Low Carbon Steel Ex. 1018, 1020, 1117, 1141, 12L14	700 - 900	.006 - .010
High Carbon & Alloy Steel Ex. 1045, 4140, 4340, 52100, 8620	500 - 600	.006 - .010
Lower Carbon Tool Steel Ex. P-20, H-13, S-7	400 - 500	.006 - .010
Tool Steel Ex. A-2, A-6, D-2, M-2	350 - 450	.006 - .010
Stainless Steel Ex. 304, 316, 420, 15-5PH, 17-4PH	350 - 550	.005 - .008
Iron Ex. Cast, Ductile, Nodular	600 - 800	.008 - .014
Nickel & Titanium Alloy Ex. Inconel, Hastelloy, Ti-6AL-4V	100 - 200	.003 - .005
Non-Ferrous Metal Ex. Aluminum, Bronze, Brass	1000 - 2000	.008 - .014

Drill Mills

1 Effective Center Cutting Endmills

Available Modifications

- Modified Diameters
- Reduce Shank Diameters
- Shift Center Insert to Remove Center Nib
- Coolant Thru
- 2 - 3 Day Delivery

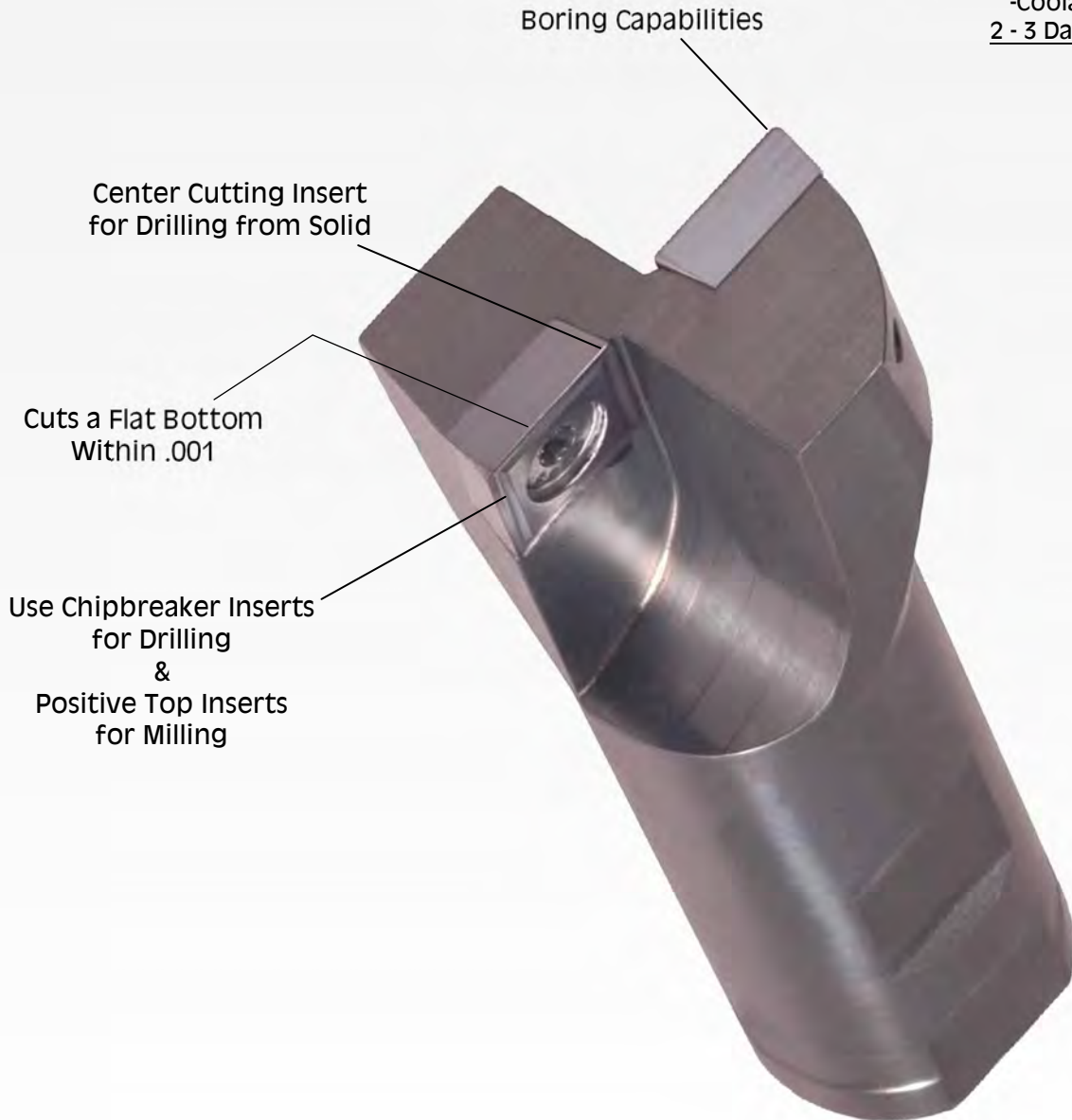

Applications

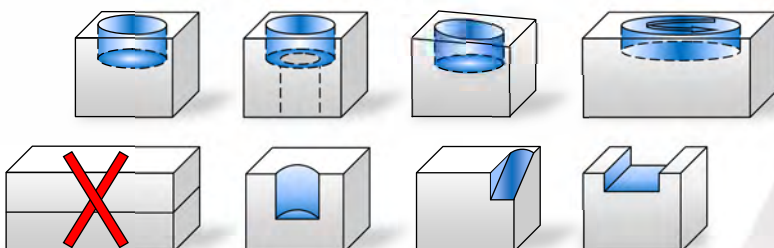

1 Effective Center Cutting Endmills

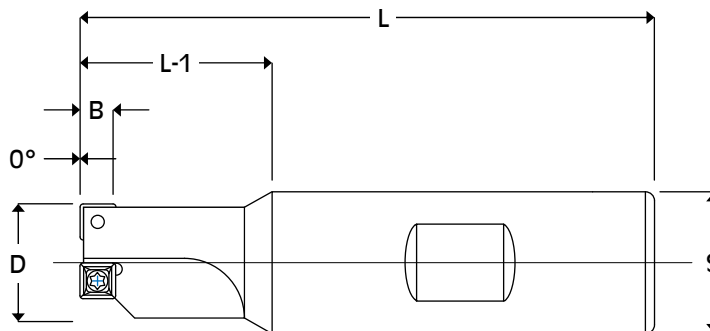

Tool Info.

Tool #	D	Inserts	L	L-1	B	S	Positive Top Inserts	Chipbreaker Inserts	Screw	Wrench
DM-375	.375	1	2.500	.625	.170	.500	N/A	SDEB-1511CB	164T	T-6
DM-500	.500	1	2.625	.625	.235	.500	SDEB-2151P	SDEB-2151CB	300T	T-8
DM-502	.500	2	2.625	.875	.170	.500	N/A	SPEB-1511CB	164T	T-6
DM-531	.531	2	2.625	.875	.170	.500				
DM-562	.562	2	3.000	1.000	.170	.750				
DM-593	.593	2	3.000	1.000	.170	.750	SDEB-2522P	SDEB-2522CB	300T	T-8
DM-625	.625	1	3.000	1.000	.280	.750				
DM-656	.656	2	3.000	.940	.170	.750	N/A	SPEB-1511CB	164T	T-6

Chipbreaker Inserts

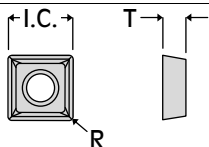

Insert Info.

Insert #	I.C.	T	R	Grades
SDEB-1511CB	.187	.082	.015	X33
SPEB-1511CB	.187	.082	.015	X33 X40
SDEB-2151CB	.250	.093	.015	X33
SDEB-2522CB	.312	.125	.031	X33

IMPORTANT

Use Chipbreaker Inserts for Drilling & C-Boring.
Use Positive Top Inserts for Ramping or Pocket Milling.

Positive Top Inserts

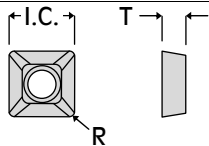

Insert Info.

Insert #	I.C.	T	R	Grade
SDEB-2151P	.250	.093	.015	X33
SDEB-2522P	.312	.125	.031	

Speed and Feed Info.

Material	S.F.M.	Drilling I.P.R.	Milling I.P.R.
Mild & Low Carbon Steel Ex. 1018, 1020, 1117, 1141, 12L14	800 - 1200	.001 - .003	.002 - .003
High Carbon & Alloy Steel Ex. 1045, 4140, 4340, 52100, 8620	500 - 800	.001 - .003	.002 - .003
Lower Carbon Tool Steel Ex. P-20, H-13, S-7	400 - 700	.001 - .003	.002 - .003
Tool Steel Ex. A-2, A-6, D-2, M-2	300 - 600	.001 - .003	.002 - .003
Stainless Steel Ex. 304, 316, 420, 15-5PH, 17-4PH	300 - 600	.001 - .003	.002 - .003
Iron Ex. Cast, Ductile, Nodular	600 - 1000	.002 - .003	.002 - .003
Nickel & Titanium Alloy Ex. Inconel, Hastelloy, Ti-6AL-4V	120 - 180	.001 - .0015	.001 - .002
Non-Ferrous Metal Ex. Aluminum, Bronze, Brass	1000 - 2500	.002 - .003	.002 - .003

1 Effective Center Cutting Endmills

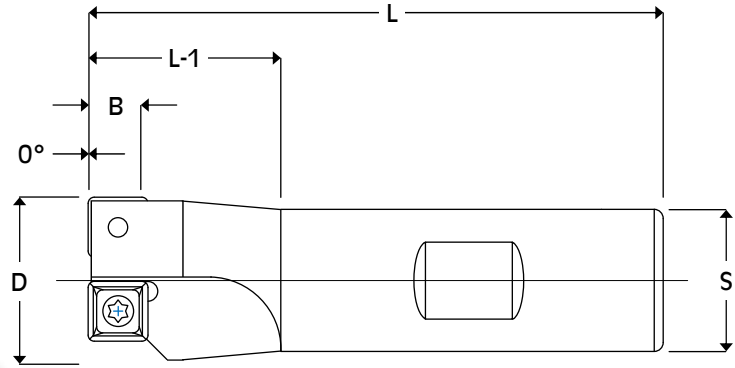

Tool Info.

Tool #	D	Inserts	L	L-1	B	S	Positive Top Insert	Chipbreaker Insert	Screw	Wrench
DM-687	.687	2	3.000	.970	.235	.750	SPEB-221P	SPEB-221CB	314T	T-8
DM-718	.718	2	3.000	1.000	.235	.750				
DM-750	.750	1	3.000	1.000	.340	.750	SPEB-322P	SPEB-322CB	414T	T-10
XDM-750	.750	1	4.250	1.500	.340	.750				
DM-752	.750	2	3.000	1.000	.235	.750	SPEB-221P	SPEB-221CB	314T	T-8
XDM-752	.750	2	4.250	1.500	.235	.750				
DM-781	.781	2	3.000	1.000	.235	.750	SPEB-2522P	SPEB-2522CB	314T	T-8
DM-812	.812	2	3.000	1.000	.280	.750				
DM-875	.875	2	3.000	1.000	.280	.750				
DM-937	.937	2	3.250	1.250	.280	.750				

Chipbreaker Inserts

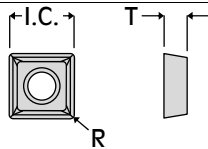

Insert Info.

Insert #	I.C.	T	R	Grades
SPEB-221CB	.250	.125	.015	X33 X40
SPEB-2522CB	.312	.125	.031	X33 X40
SPEB-322CB	.375	.125	.031	X33 X40

IMPORTANT

Use Chipbreaker Inserts for Drilling & C-Boring.
Use Positive Top Inserts for Ramping or Pocket Milling.

Positive Top Inserts

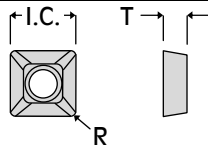

Insert Info.

Insert #	I.C.	T	R	Grades
SPEB-221P	.250	.125	.015	X33
SPEB-2522P	.312	.125	.031	A9M B1M X33 X40
SPEB-322P	.375	.125	.031	A9M B1M X33 X40

Speed and Feed Info.

Material	S.F.M.	Drilling I.P.R.	Milling I.P.R.
Mild & Low Carbon Steel Ex. 1018, 1020, 1117, 1141, 12L14	800 - 1200	.002 - .004	.002 - .004
High Carbon & Alloy Steel Ex. 1045, 4140, 4340, 52100, 8620	500 - 800	.002 - .003	.002 - .004
Lower Carbon Tool Steel Ex. P-20, H-13, S-7	400 - 700	.002 - .003	.002 - .004
Tool Steel Ex. A-2, A-6, D-2, M-2	300 - 600	.001 - .003	.002 - .004
Stainless Steel Ex. 304, 316, 420, 15-5PH, 17-4PH	300 - 600	.001 - .003	.002 - .004
Iron Ex. Cast, Ductile, Nodular	600 - 1000	.002 - .005	.002 - .005
Nickel & Titanium Alloy Ex. Inconel, Hastelloy, Ti-6AL-4V	120 - 180	.001 - .002	.001 - .002
Non-Ferrous Metal Ex. Aluminum, Bronze, Brass	1000 - 2500	.003 - .006	.002 - .004

1 Effective Center Cutting Endmills

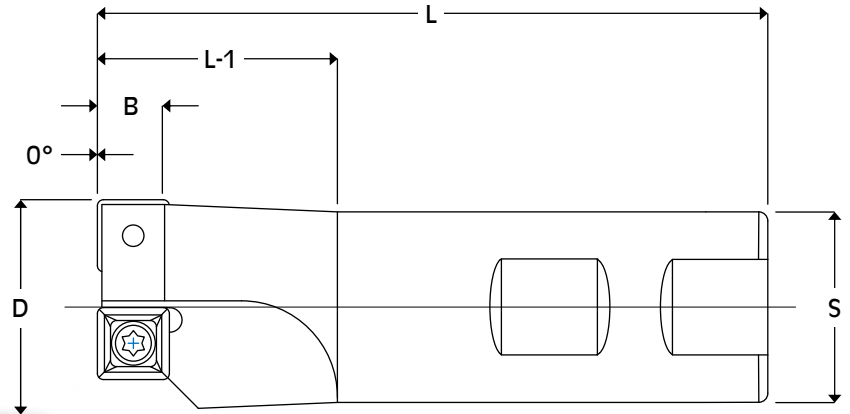
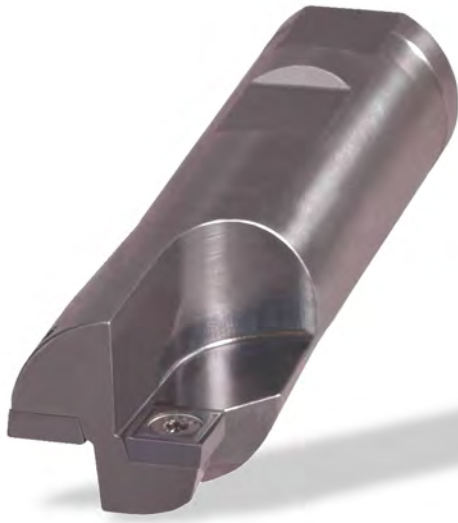

Tool Info.

Tool #	D	Inserts	L	L-1	B	S	Positive Top Insert	Chipbreaker Insert	Screw	Wrench
DM-1000	1.000	2	3.250	1.250	.340	.750	SPEB-322P	SPEB-322CB	414T	T-10
XDM-1000	1.000	2	5.250	2.000	.340	1.000				
DM-1125	1.125	2	3.500	1.250	.340	1.000				
DM-1250	1.250	2	3.625	1.375	.340	1.000				
XDM-1250	1.250	2	5.250	1.375	.340	1.000			438T	

IMPORTANT

Use Chipbreaker Inserts for Drilling & C-Boring.
Use Positive Top Inserts for Ramping or Pocket Milling.

Chipbreaker Insert

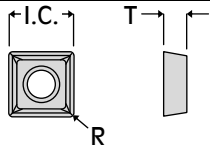

Insert Info.

Insert #	I.C.	T	R	Grades
SPEB-322CB	.375	.125	.031	X33 X40

Positive Top Insert

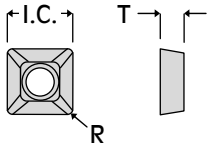

Insert Info.

Insert #	I.C.	T	R	Grades
SPEB-322P	.375	.125	.031	A9M B1M X33 X40

Speed and Feed Info.

Material	S.F.M.	Drilling I.P.R.	Milling I.P.R.
Mild & Low Carbon Steel Ex. 1018, 1020, 1117, 1141, 12L14	800 - 1200	.002 - .004	.002 - .005
High Carbon & Alloy Steel Ex. 1045, 4140, 4340, 52100, 8620	500 - 800	.002 - .004	.002 - .005
Lower Carbon Tool Steel Ex. P-20, H-13, S-7	400 - 700	.002 - .004	.002 - .005
Tool Steel Ex. A-2, A-6, D-2, M-2	300 - 600	.002 - .003	.002 - .004
Stainless Steel Ex. 304, 316, 420, 15-5PH, 17-4PH	300 - 600	.002 - .003	.002 - .004
Iron Ex. Cast, Ductile, Nodular	600 - 1000	.002 - .004	.002 - .006
Nickel & Titanium Alloy Ex. Inconel, Hastelloy, Ti-6AL-4V	120 - 180	.001 - .002	.001 - .002
Non-Ferrous Metal Ex. Aluminum, Bronze, Brass	1000 - 2500	.002 - .004	.003 - .006

1 Effective Center Cutting Endmills

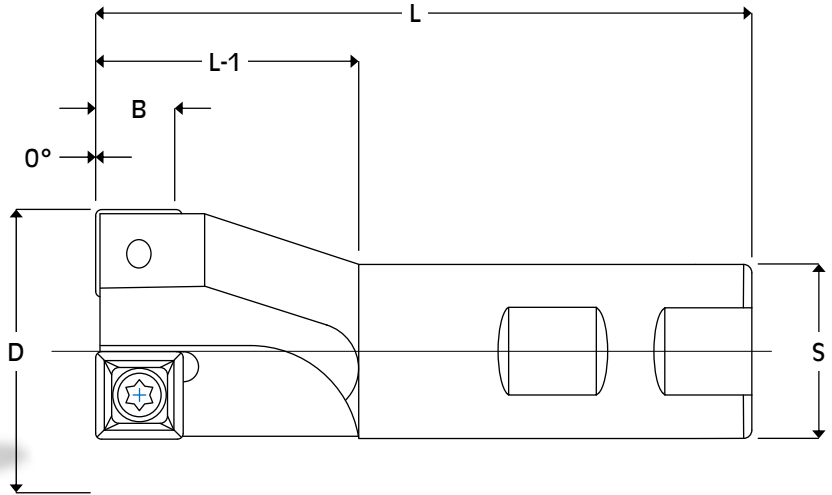
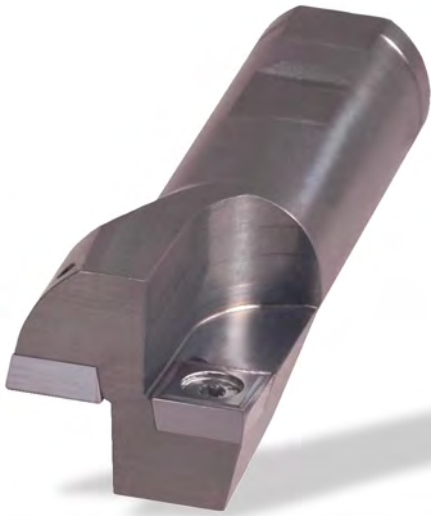

Tool Info.

Tool #	D	Inserts	L	L-1	B	S	Positive Top Insert	Chipbreaker Insert	Screw	Wrench
DM-1375	1.375	2	3.625	1.375	.465	1.000	SPEB-432PA	SPEB-432CB	638T	T-15
DM-1500	1.500	2	3.625	1.375	.465	1.000				
XDM-1500	1.500	2	5.250	1.375	.465	1.000				
DM-1625	1.625	2	3.750	1.500	.465	1.000				
DM-1750	1.750	2	3.750	1.500	.465	1.000				
DM-1875	1.875	2	3.875	1.625	.585	1.000	SPEB-532PA	SPEB-532CB	838T	T-20

IMPORTANT

Use Chipbreaker Inserts for Drilling & C-Boring.
Use Positive Top Inserts for Ramping or Pocket Milling.

Chipbreaker Insert

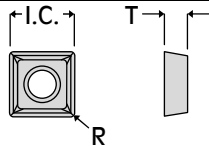

Insert Info.

Insert #	I.C.	T	R	Grades
SPEB-432CB	.500	.187	.031	X33 X40
SPEB-532CB	.625	.187	.031	X33

Positive Top Insert

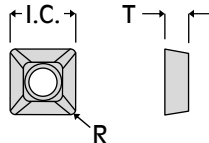

Insert Info.

Insert #	I.C.	T	R	Grades
SPEB-432PA	.500	.187	.031	A9M B1M X33 X40
SPEB-532PA	.625	.187	.031	X33

Speed and Feed Info.

Material	S.F.M.	Drilling I.P.R.	Milling I.P.R.
Mild & Low Carbon Steel Ex. 1018, 1020, 1117, 1141, 12L14	800 - 1200	.003 - .005	.002 - .005
High Carbon & Alloy Steel Ex. 1045, 4140, 4340, 52100, 8620	500 - 800	.003 - .005	.002 - .005
Lower Carbon Tool Steel Ex. P-20, H-13, S-7	400 - 700	.003 - .005	.002 - .005
Tool Steel Ex. A-2, A-6, D-2, M-2	300 - 600	.002 - .004	.002 - .004
Stainless Steel Ex. 304, 316, 420, 15-5PH, 17-4PH	300 - 600	.002 - .004	.002 - .004
Iron Ex. Cast, Ductile, Nodular	600 - 1000	.003 - .006	.002 - .006
Nickel & Titanium Alloy Ex. Inconel, Hastelloy, Ti-6AL-4V	120 - 180	.002 - .003	.001 - .002
Non-Ferrous Metal Ex. Aluminum, Bronze, Brass	1000 - 2500	.004 - .008	.003 - .006

1 Effective Center Cutting Endmills

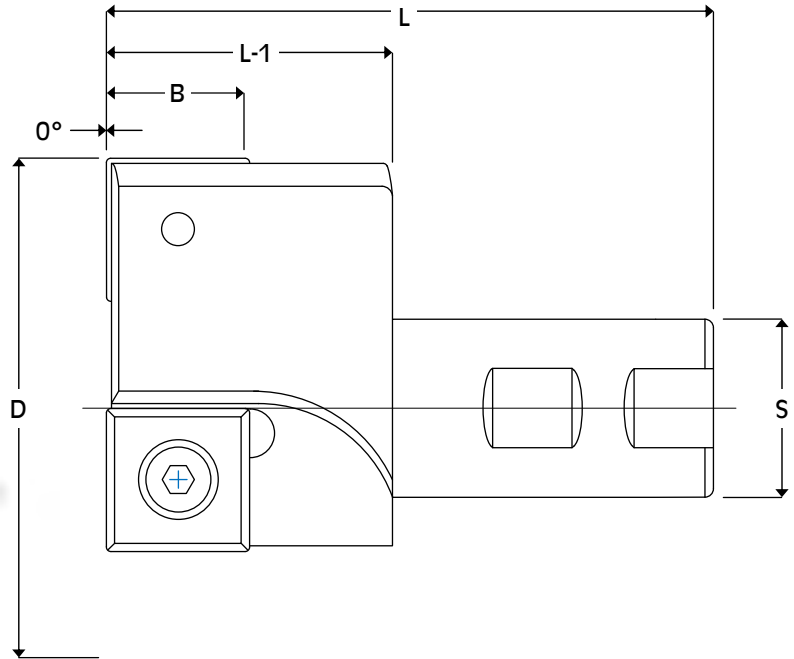
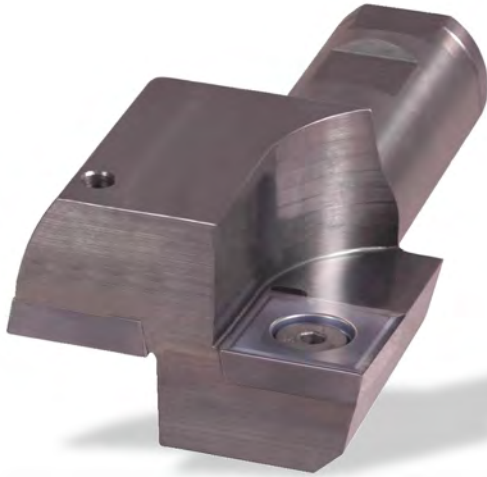

Tool Info.

Tool #	D	Inserts	L	L-1	B	S	Positive Top Insert	Chipbreaker Insert	Screw	Wrench
DM-2001	2.000	2	4.000	1.750	.710	1.000	SPEB-6352PA	SPEB-6352CB	1012T	T-25
XDM-2000	2.000	2	5.500	1.500	.710	1.250				
DM-2250	2.250	2	4.000	1.750	.710	1.000				
DM-2500	2.500	2	4.000	1.750	.710	1.000	SPEB-842PA	SPEB-842CB	1412T	T-532
DM-3000	3.000	2	4.250	2.000	.960	1.250				
DM-3500	3.500	2	4.250	2.000	.960	1.250				

IMPORTANT

Use Chipbreaker Inserts for Drilling & C-Boring.
Use Positive Top Inserts for Ramping or Pocket Milling.

Chipbreaker Inserts

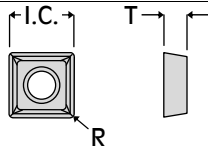

Insert Info.

Insert #	I.C.	T	R	Grades
SPEB-6352CB	.750	.220	.031	X33 X40
SPEB-842CB	1.000	.250	.031	X33

Positive Top Inserts

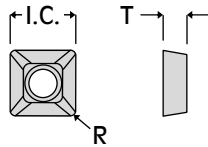

Insert Info.

Insert #	I.C.	T	R	Grades
SPEB-6352PA	.750	.220	.031	X33 X40
SPEB-842PA	1.000	.250	.031	X33

Speed and Feed Info.

Material	S.F.M.	Drilling I.P.R.	Milling I.P.R.
Mild & Low Carbon Steel Ex. 1018, 1020, 1117, 1141, 12L14	800 - 1200	.003 - .005	.002 - .005
High Carbon & Alloy Steel Ex. 1045, 4140, 4340, 52100, 8620	500 - 800	.003 - .005	.002 - .005
Lower Carbon Tool Steel Ex. P-20, H-13, S-7	400 - 700	.003 - .005	.002 - .005
Tool Steel Ex. A-2, A-6, D-2, M-2	300 - 600	.002 - .004	.002 - .004
Stainless Steel Ex. 304, 316, 420, 15-5PH, 17-4PH	300 - 600	.002 - .004	.002 - .004
Iron Ex. Cast, Ductile, Nodular	600 - 1000	.003 - .006	.002 - .006
Nickel & Titanium Alloy Ex. Inconel, Hastelloy, Ti-6AL-4V	120 - 180	.002 - .003	.001 - .002
Non-Ferrous Metal Ex. Aluminum, Bronze, Brass	1000 - 2500	.004 - .008	.003 - .006

Drill Mill Twins

Available Modifications

- Reduce Shank Diameters
- Coolant Thru

2 - 3 Day Delivery

Cuts a Flat Bottom
Within .001

2 Flutes Effective when
Milling & Counterboring



Applications

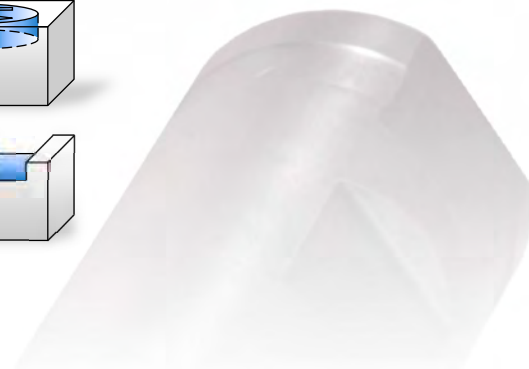
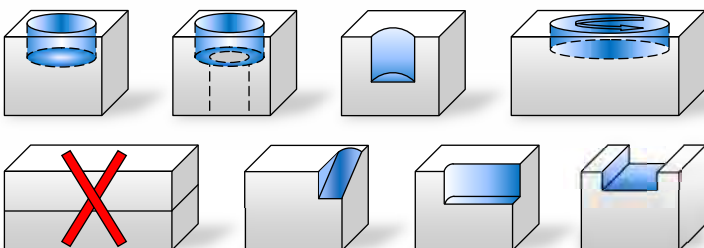

2 Effective Center Cutting Endmills

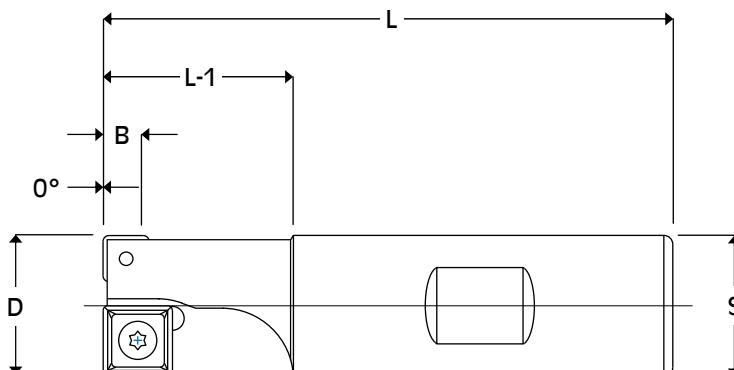

Tool Info.								
Tool #	D	L	L-1	B	S	Inserts	Screw	Wrench
DMT-500	.500	2.625	.625	.170	.500	(1) SDEB-1511CB (1) SDEB-2151CB	164T 300T	T-6 T-8
XDMT-500	.500	3.500	1.000	.170	.500	(1) SDEB-1511CB (1) SDEB-2151CB	164T 300T	T-6 T-8

Chipbreaker Inserts				
Insert Info.				
Insert #	I.C.	T	R	Grade
SDEB-1511CB	.187	.082	.015	X33
SDEB-2151CB	.250	.093	.015	X33

Speed and Feed Info.			
Material	S.F.M.	Drilling I.P.R.	Milling I.P.R.
Mild & Low Carbon Steel Ex. 1018, 1020, 1117, 1141, 12L14	800 - 1200	.0015 - .003	.004 - .006
High Carbon & Alloy Steel Ex. 1045, 4140, 4340, 52100, 8620	500 - 800	.0015 - .002	.004 - .006
Lower Carbon Tool Steel Ex. P-20, H-13, S-7	400 - 700	.0015 - .002	.004 - .006
Tool Steel Ex. A-2, A-6, D-2, M-2	300 - 600	.0015 - .002	.004 - .006
Stainless Steel Ex. 304, 316, 420, 15-5PH, 17-4PH	300 - 600	.0015 - .002	.004 - .006
Iron Ex. Cast, Ductile, Nodular	600 - 1000	.0015 - .004	.004 - .007
Nickel & Titanium Alloy Ex. Inconel, Hastelloy, Ti-6AL-4V	120 - 180	.0015 - .002	.002 - .004
Non-Ferrous Metal Ex. Aluminum, Bronze, Brass	1000 - 2500	.0015 - .004	.004 - .007

2 Effective Center Cutting Endmills

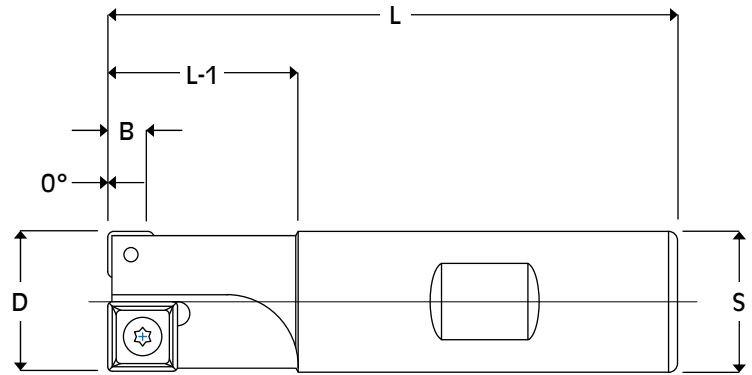

Tool Info.									
Tool #	D	L	L-1	B	S	(Milling) Inserts	(Drilling)	Screw	Wrench
DMT-625	.625	3.000	1.000	.215	.750	(1) <i>SDEB-2522P</i>	(1) <i>SDEB-2522CB</i>	300T	T-8
XDMT-625	.625	4.000	1.250	.215	.750	& or (1) <i>SPEB-222P</i>	& (1) <i>SPEB-222CB</i>		
DMT-750	.750	3.000	1.000	.215	.750	(1) <i>SPEB-322P</i>	(1) <i>SPEB-322CB</i>	414T	T-10
XDMT-750	.750	4.250	1.500	.215	.750	& or (1) <i>SPEB-222P</i>	& (1) <i>SPEB-222CB</i>	314T	T-8

Chipbreaker Inserts
(Drilling or C-Boring)

Insert Info.				
Insert #	I.C.	T	R	Grades
SPEB-222CB	.250	.125	.031	X33
SDEB-2522CB	.312	.125	.031	X33
SPEB-322CB	.375	.125	.031	X33 X40

Positive Top Inserts
(Milling)

Insert Info.				
Insert #	I.C.	T	R	Grades
SPEB-222P	.250	.125	.031	A9M X33
SDEB-2522P	.312	.125	.031	X33
SPEB-322P	.375	.125	.031	A9M X33 X40

IMPORTANT
When ordering inserts
Order all **Positive Top** Inserts When Ramping or Pocket Milling
Order all **Chipbreaker** Inserts When Drilling or C-Boring

Speed and Feed Info.			
Material	S.F.M.	Drilling I.P.R.	Milling I.P.R.
Mild & Low Carbon Steel Ex. 1018, 1020, 1117, 1141, 12L14	800 - 1200	.003 - .005	.004 - .008
High Carbon & Alloy Steel Ex. 1045, 4140, 4340, 52100, 8620	500 - 800	.003 - .005	.004 - .008
Lower Carbon Tool Steel Ex. P-20, H-13, S-7	400 - 700	.003 - .005	.004 - .008
Tool Steel Ex. A-2, A-6, D-2, M-2	300 - 600	.003 - .005	.004 - .008
Stainless Steel Ex. 304, 316, 420, 15-5PH, 17-4PH	300 - 600	.003 - .005	.004 - .008
Iron Ex. Cast, Ductile, Nodular	600 - 1000	.003 - .005	.004 - .010
Nickel & Titanium Alloy Ex. Inconel, Hastelloy, Ti-6AL-4V	120 - 180	.002 - .004	.002 - .004
Non-Ferrous Metal Ex. Aluminum, Bronze, Brass	1000 - 2500	.003 - .005	.004 - .010

2 Effective Center Cutting Endmills

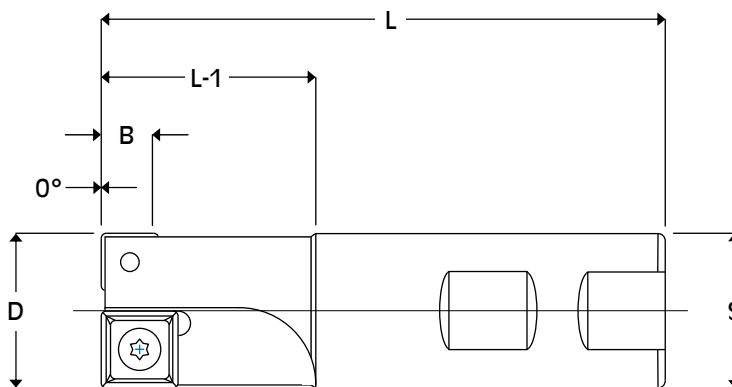

Tool Info.									
Tool #	D	L	L-1	B	S	(Milling) Inserts	(Drilling)	Screw	Wrench
DMT-875	.875	3.625	1.375	.280	1.000	(1) <i>SPEB-3522PA</i> & (1) <i>SPEB-2522P</i>	N/A & (1) <i>SPEB-2522CB</i>	614T 314T	T-15 T-8
DMT-100	1.000	3.625	1.375	.340	1.000	(1) <i>SPEB-422PA</i> & (1) <i>SPEB-322P</i>	(1) <i>SPEB-422CB</i> & (1) <i>SPEB-322CB</i>	638T 414T	T-15 T-10

Chipbreaker Inserts (Drilling or C-Boring)				
Insert Info.				
Insert #	I.C.	T	R	Grades
SPEB-2522CB	.312	.125	.031	X33 X40
SPEB-322CB	.375	.125	.031	X33 X40
SPEB-422CB	.500	.125	.031	X33

Positive Top Inserts (Milling)				
Insert Info.				
Insert #	I.C.	T	R	Grades
SPEB-2522P	.312	.125	.031	A9M X33 X40
SPEB-322P	.375	.125	.031	A9M X33 X40
SPEB-3522P	.437	.125	.031	X33
SPEB-422PA	.500	.125	.031	X33

IMPORTANT
When ordering inserts
Order all **Positive Top** Inserts When Ramping or Pocket Milling
Order all **Chipbreaker** Inserts When Drilling or C-Boring

Speed and Feed Info.			
Material	S.F.M.	Drilling I.P.R.	Milling I.P.R.
Mild & Low Carbon Steel Ex. 1018, 1020, 1117, 1141, 12L14	800 - 1200	.003 - .005	.004 - .008
High Carbon & Alloy Steel Ex. 1045, 4140, 4340, 52100, 8620	500 - 800	.003 - .005	.004 - .008
Lower Carbon Tool Steel Ex. P-20, H-13, S-7	400 - 700	.003 - .005	.004 - .008
Tool Steel Ex. A-2, A-6, D-2, M-2	300 - 600	.003 - .005	.004 - .008
Stainless Steel Ex. 304, 316, 420, 15-5PH, 17-4PH	300 - 600	.003 - .005	.004 - .008
Iron Ex. Cast, Ductile, Nodular	600 - 1000	.003 - .005	.004 - .010
Nickel & Titanium Alloy Ex. Inconel, Hastelloy, Ti-6AL-4V	120 - 180	.002 - .004	.002 - .004
Non-Ferrous Metal Ex. Aluminum, Bronze, Brass	1000 - 2500	.003 - .005	.004 - .010

2 Effective Center Cutting Endmills

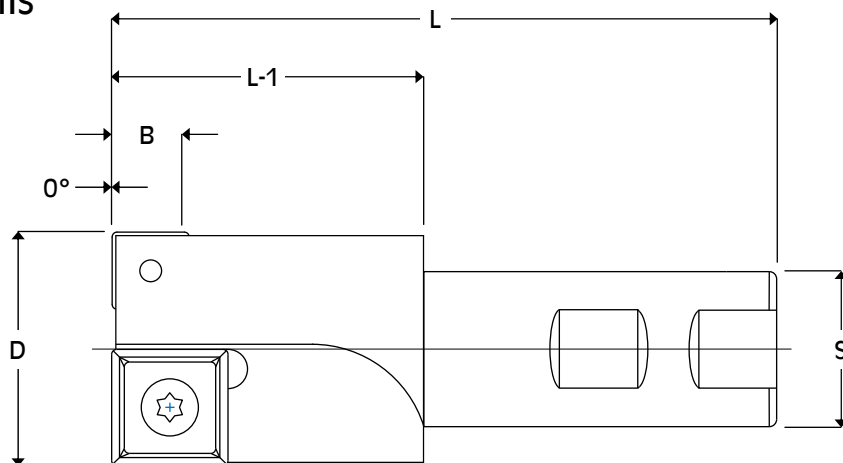
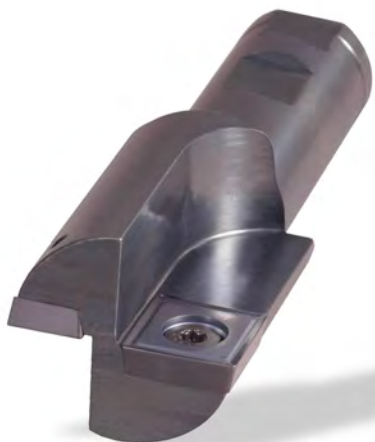

Tool Info.

Tool #	D	L	L-1	B	S	(Milling) Inserts	(Drilling)	Screw	Wrench
DMT-1250	1.250	4.000	1.750	.465	1.000	(1) <i>SPEB-432PA</i>	(1) <i>SPEB-432CB</i>	638T	T-15
XDMT-1250	1.250	5.000	2.750	.465	1.250	(1) <i>SPEB-532PA</i>	(1) <i>SPEB-532CB</i>	838T	T-20
DMT-1500	1.500	4.250	2.000	.465	1.000	(1) <i>SPEB-432PA</i>	(1) <i>SPEB-432CB</i>	638T	T-15
XDMT-1500	1.500	5.250	3.000	.465	1.250	(1) <i>SPEB-6352PA</i>	(1) <i>SPEB-6352CB</i>	1012T	T-25
DMT-2000	2.000	4.750	2.500	.715	1.250	(1) <i>SPEB-6352PA</i>	(1) <i>SPEB-6352CB</i>	1012T	T-25
XDMT-2000	2.000	6.250	4.000	.715	1.250	(1) <i>SPEB-842PA</i>	(1) <i>SPEB-842CB</i>	1412T	T-532

Chipbreaker Inserts

(Drilling or C-Boring)

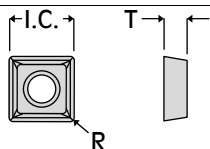

Insert Info.

Insert #	I.C.	T	R	Grades
SPEB-432CB	.500	.187	.031	X33 X40
SPEB-532CB	.625	.187	.031	X33
SPEB-6352CB	.750	.220	.031	X33 X40
SPEB-842CB	1.000	.250	.031	X33

Positive Top Inserts

(Milling)

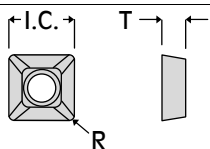

Insert Info.

Insert #	I.C.	T	R	Grades
SPEB-432PA	.500	.187	.031	A9M X33 X40
SPEB-532PA	.625	.187	.031	X33
SPEB-6352PA	.750	.220	.031	X33 X40
SPEB-842PA	1.000	.250	.031	X33

IMPORTANT

When ordering inserts

Order all **Positive Top** Inserts When Ramping or Pocket Milling
Order all **Chipbreaker** Inserts When Drilling or C-Boring

Speed and Feed Info.

Material	S.F.M.	Drilling I.P.R.	Milling I.P.R.
Mild & Low Carbon Steel Ex. 1018, 1020, 1117, 1141, 12L14	800 - 1200	.003 - .005	.004 - .008
High Carbon & Alloy Steel Ex. 1045, 4140, 4340, 52100, 8620	500 - 800	.003 - .005	.004 - .008
Lower Carbon Tool Steel Ex. P-20, H-13, S-7	400 - 700	.003 - .005	.004 - .008
Tool Steel Ex. A-2, A-6, D-2, M-2	300 - 600	.003 - .005	.004 - .008
Stainless Steel Ex. 304, 316, 420, 15-5PH, 17-4PH	300 - 600	.003 - .005	.004 - .008
Iron Ex. Cast, Ductile, Nodular	600 - 1000	.003 - .005	.004 - .010
Nickel & Titanium Alloy Ex. Inconel, Hastelloy, Ti-6AL-4V	120 - 180	.002 - .004	.002 - .004
Non-Ferrous Metal Ex. Aluminum, Bronze, Brass	1000 - 2500	.003 - .005	.004 - .010

Drill Mill Twin Long Edge

Available Modifications

- Reduce Shank Diameters
- Coolant Thru

2 - 3 Day Delivery

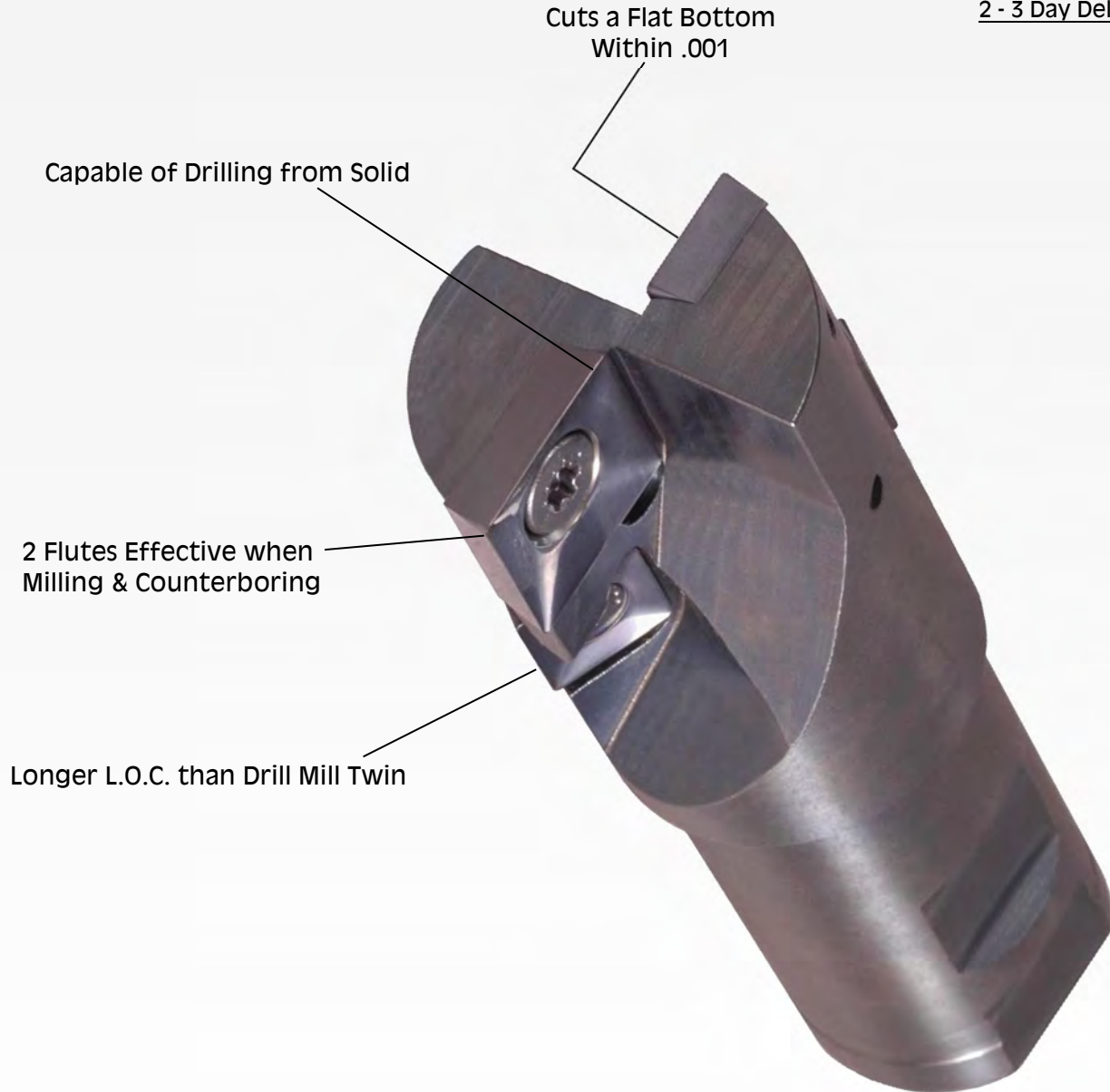

Applications

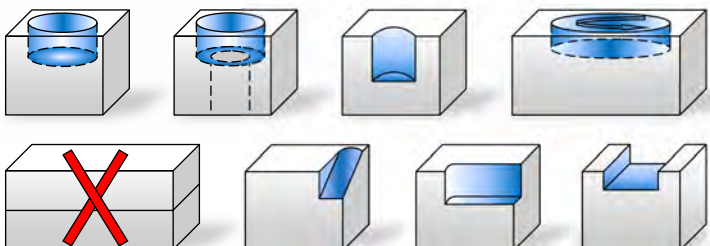

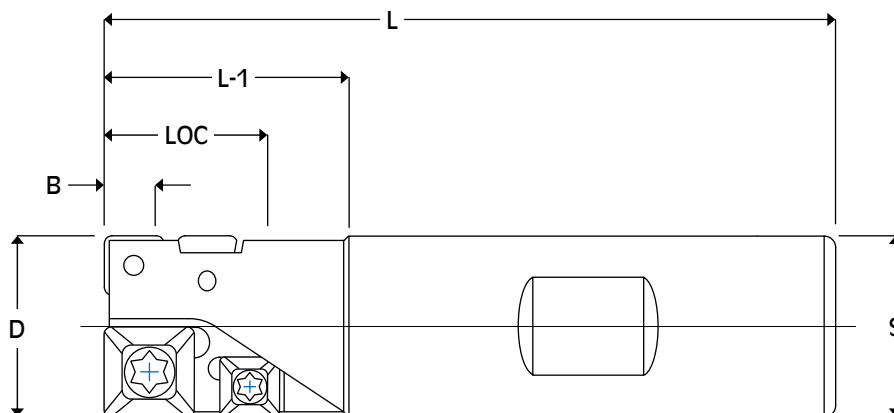

Important : DMTL's are to be run as 1 flute effective at depths more than B dimension.

Tool Info.

Tool #	D	L	L-1	B	LOC	S	Inserts	Screw Wrench	Center Insert	Screw Wrench
DMTL-750	.750	3.000	1.000	.215	.700	.750	(3) SPEB-222P	314T T-8	(1) SPEB-322P	414T T-10
DMTL-100	1.000	3.750	1.500	.280	.900	1.000	(3) SPEB-2522P	314T T-8	(1) SPEB-422PA	638T T-15

Speed and Feed Info.

Material	S.F.M.	Drilling I.P.R.	Milling I.P.R.
Mild & Low Carbon Steel Ex. 1018, 1020, 1117, 1141, 12L14	400 - 800	.002 - .004	.002 - .005
High Carbon & Alloy Steel Ex. 1045, 4140, 4340, 52100, 8620	300 - 500	.002 - .003	.002 - .004
Lower Carbon Tool Steel Ex. P-20, H-13, S-7	300 - 500	.002 - .003	.002 - .004
Tool Steel Ex. A-2, A-6, D-2, M-2	300 - 500	.001 - .003	.001 - .004
Stainless Steel Ex. 304, 316, 420, 15-5PH, 17-4PH	300 - 500	.001 - .003	.001 - .003
Iron Ex. Cast, Ductile, Nodular	400 - 800	.002 - .005	.002 - .006
Nickel & Titanium Alloy Ex. Inconel, Hastelloy, Ti-6AL-4V	100 - 200	.001 - .002	.001 - .002
Non-Ferrous Metal Ex. Aluminum, Bronze, Brass	800 - 1200	.003 - .006	.003 - .008

Positive Top Inserts

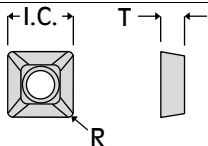

Insert Info.

Insert #	I.C.	T	R	Grades
SPEB-222P	.250	.125	.031	A9M X33
SPEB-2522P	.312	.125	.031	A9M X33 X40
SPEB-322P	.375	.125	.031	A9M X33 X40
SPEB-422PA	.500	.125	.031	X33

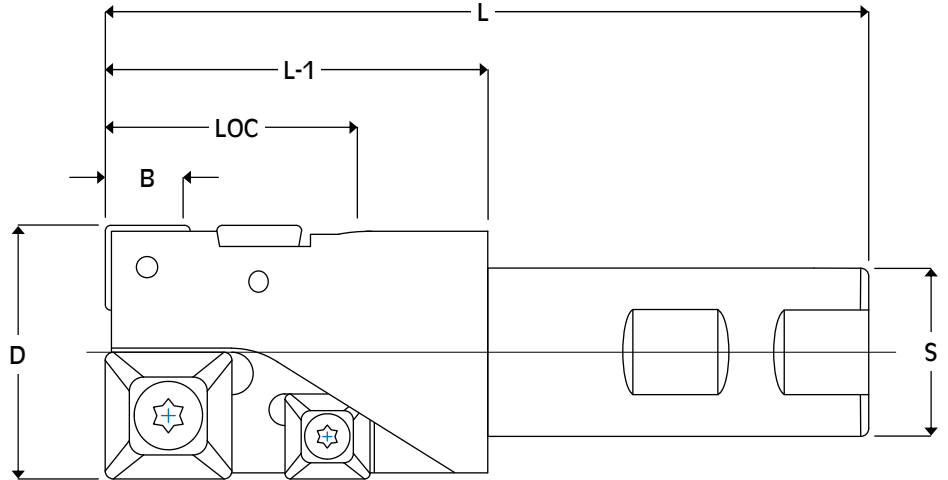

Important : DMTL's are to be run as 1 flute effective at depths more than B dimension.

<i>Tool Info.</i>										
Tool #	D	L	L-1	B	LOC	S	Inserts	Screw Wrench	Center Insert	Screw Wrench
DMTL-1500	1.500	4.500	2.250	.465	1.500	1.250	(3) SPEB-432PA	$\frac{638T}{T-15}$	(1) SPEB-6352PA	$\frac{1012T}{T-25}$
DMTL-2000	2.000	5.687	3.000	.715	2.125	1.500	(3) SPEB-6352PA	$\frac{1012T}{T-25}$	(1) SPEB-842PA	$\frac{1412T}{T-532}$

<i>Insert Info.</i>				
Insert #	I.C.	T	R	Grades
SPEB-432PA	.500	.187	.031	A9M X33 X40
SPEB-6352PA	.750	.220	.031	X33 X40
SPEB-842PA	1.000	.250	.031	X33

Positive Top Inserts

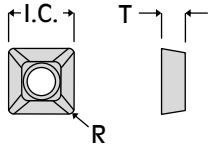

<i>Speed and Feed Info.</i>			
Material	S.F.M.	Drilling I.P.R.	Milling I.P.R.
Mild & Low Carbon Steel Ex. 1018, 1020, 1117, 1141, 12L14	400 - 800	.002 - .004	.002 - .005
High Carbon & Alloy Steel Ex. 1045, 4140, 4340, 52100, 8620	300 - 500	.002 - .003	.002 - .004
Lower Carbon Tool Steel Ex. P-20, H-13, S-7	300 - 500	.002 - .003	.002 - .004
Tool Steel Ex. A-2, A-6, D-2, M-2	300 - 500	.001 - .003	.001 - .004
Stainless Steel Ex. 304, 316, 420, 15-5PH, 17-4PH	300 - 500	.001 - .003	.001 - .003
Iron Ex. Cast, Ductile, Nodular	400 - 800	.002 - .005	.002 - .006
Nickel & Titanium Alloy Ex. Inconel, Hastelloy, Ti-6AL-4V	100 - 200	.001 - .002	.001 - .002
Non-Ferrous Metal Ex. Aluminum, Bronze, Brass	800 - 1200	.003 - .006	.003 - .008

FEC-Mills

Available Modifications

- Reduce Shank Diameters
- Coolant Thru

2 - 3 Day Delivery

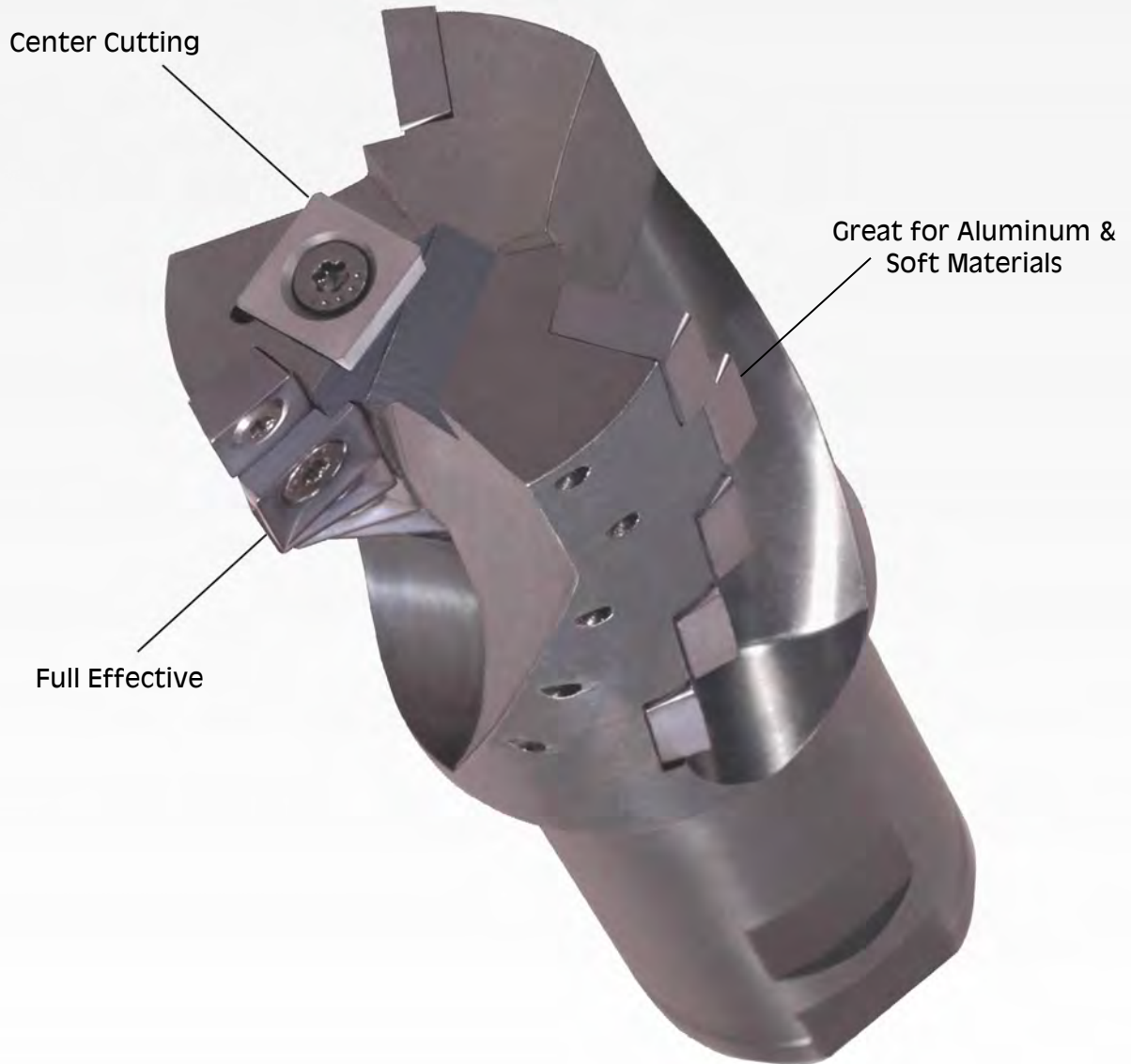

Applications

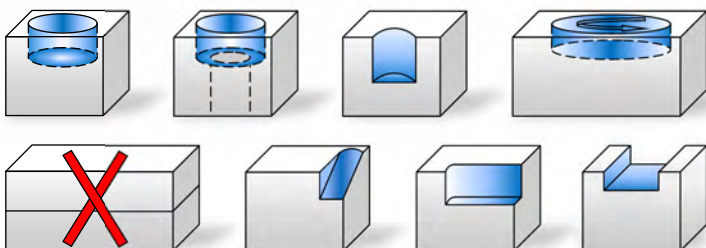

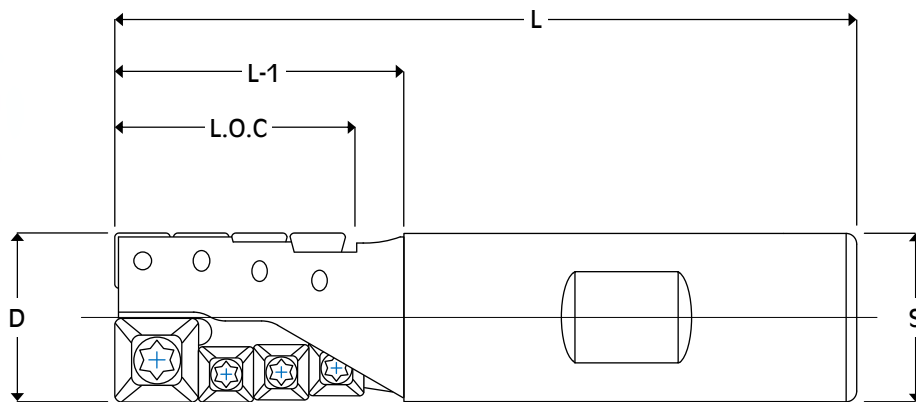

Tool Info.

Tool #	D	Flutes	L	L-1	LOC	S	Insert	Screw Wrench	Center Insert	Screw Wrench
FEC-750	.750	2	3.625	1.375	1.100	.750	(7)SPEB-222P	$\frac{314T}{T-8}$	(1)SPEB-322P	$\frac{414T}{T-10}$
FEC-100	1.000	2	4.250	2.000	1.500	1.000	(8)SPEB-2522P	$\frac{314T}{T-8}$	(1)SPEB-422PA	$\frac{638T}{T-15}$

Positive Top Inserts

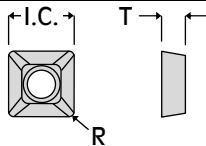

Insert Info.

Insert #	I.C.	T	R	Grades
SPEB-222P	.250	.125	.031	A9M X33
SPEB-2522P	.312	.125	.031	A9M X33 X40
SPEB-322P	.375	.125	.031	A9M X33 X40
SPEB-422PA	.500	.125	.031	X33

Speed and Feed Info.

Material	S.F.M.	Drilling I.P.R.	Milling I.P.R.
Mild & Low Carbon Steel Ex. 1018, 1020, 1117, 1141, 12L14	400 - 800	.002 - .004	.002 - .005
High Carbon & Alloy Steel Ex. 1045, 4140, 4340, 52100, 8620	300 - 500	.002 - .003	.002 - .004
Lower Carbon Tool Steel Ex. P-20, H-13, S-7	300 - 500	.002 - .003	.002 - .004
Tool Steel Ex. A-2, A-6, D-2, M-2	300 - 500	.001 - .003	.001 - .004
Stainless Steel Ex. 304, 316, 420, 15-5PH, 17-4PH	300 - 500	.001 - .003	.001 - .003
Iron Ex. Cast, Ductile, Nodular	400 - 800	.002 - .005	.002 - .006
Nickel & Titanium Alloy Ex. Inconel, Hastelloy, Ti-6AL-4V	100 - 200	.001 - .002	.001 - .002
Non-Ferrous Metal Ex. Aluminum, Bronze, Brass	800 - 1200	.003 - .006	.003 - .008

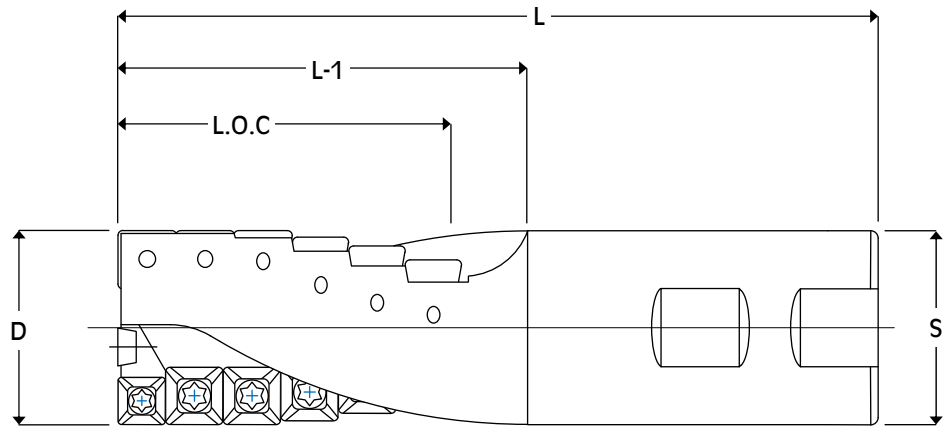

Tool Info.										
Tool #	D	Flutes	L	L-1	L.O.C	S	Inserts	Screw Wrench	Center Insert	Screw Wrench
FEC-125	1.250	2	5.125	2.625	2.200	1.250	(1)SPEB-2522P ----- (11)SPEB-332P	314T T-8 ----- 538T T-10	(1)SPEB-222F	314T T-8
FEC-150	1.500	3	5.125	2.625	2.200	1.250	(1)SPEB-2522P ----- (17)SPEB-332P	314T T-8 ----- 538T T-10	(1)SPEB-322F	438T T-10

Positive Top Inserts				
Insert Info.				
Insert #	I.C.	T	R	Grades
SPEB-2522P	.312	.125	.031	A9M X33 X40
SPEB-332P	.375	.187	.031	A9M X33 X40

Flat Top Inserts				
Insert Info.				
Insert #	I.C.	T	R	Grade
SPEB-222F	.250	.125	.031	X33
SPEB-322F	.375	.125	.031	X33

Speed and Feed Info.			
Material	S.F.M.	Drilling I.P.R.	Milling I.P.R.
Mild & Low Carbon Steel Ex. 1018, 1020, 1117, 1141, 12L14	400 - 800	.002 - .004	.002 - .005
High Carbon & Alloy Steel Ex. 1045, 4140, 4340, 52100, 8620	300 - 500	.002 - .003	.002 - .004
Lower Carbon Tool Steel Ex. P-20, H-13, S-7	300 - 500	.002 - .003	.002 - .004
Tool Steel Ex. A-2, A-6, D-2, M-2	300 - 500	.001 - .003	.001 - .004
Stainless Steel Ex. 304, 316, 420, 15-5PH, 17-4PH	300 - 500	.001 - .003	.001 - .003
Iron Ex. Cast, Ductile, Nodular	400 - 800	.002 - .005	.002 - .006
Nickel & Titanium Alloy Ex. Inconel, Hastelloy, Ti-6AL-4V	100 - 200	.001 - .002	.001 - .002
Non-Ferrous Metal Ex. Aluminum, Bronze, Brass	800 - 1200	.003 - .006	.003 - .008

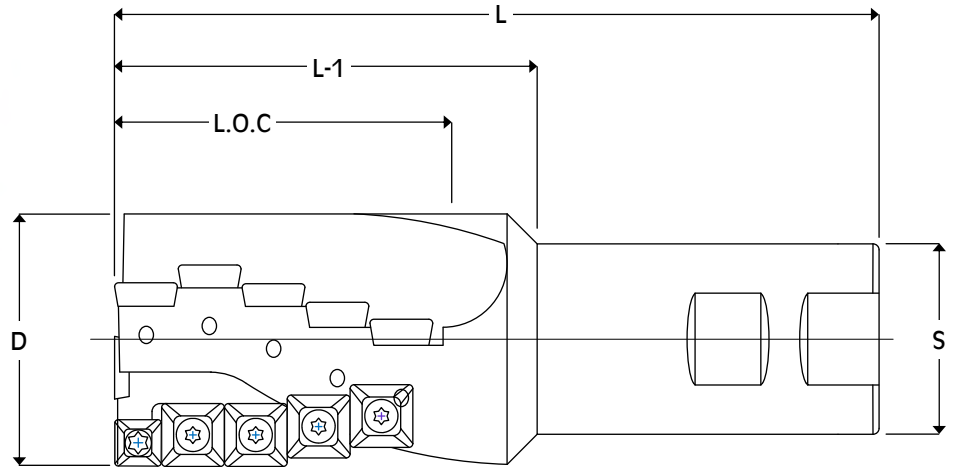

Tool Info.

Tool #	D	Flutes	L	L-1	L.O.C	S	Inserts	Screw Wrench	Center Insert	Screw Wrench
FEC-202	2.000	3	6.000	3.312	2.375	1.500	(1) SPEB-332P (14) SPEB-432PA	538T T-10 638T T-15	(1) SPEB-422F	638T T-15
FEC-204	2.000	3	7.875	4.625	3.812	2.000	(1) SPEB-332P (23) SPEB-432PA	538T T-10 638T T-15	(1) SPEB-422F	638T T-15

Positive Top Inserts

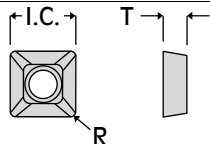

Insert Info.

Insert #	I.C.	T	R	Grades
SPEB-332P	.375	.187	.031	A9M X33 X40
SPEB-432PA	.500	.187	.031	A9M X33 X40

Flat Top Insert

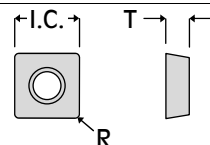

Insert Info.

Insert #	I.C.	T	R	Grade
SPEB-422F	.500	.125	.031	X33

Speed and Feed Info.

Material	S.F.M.	Drilling I.P.R.	Milling I.P.R.
Mild & Low Carbon Steel Ex. 1018, 1020, 1117, 1141, 12L14	400 - 800	.002 - .004	.002 - .005
High Carbon & Alloy Steel Ex. 1045, 4140, 4340, 52100, 8620	300 - 500	.002 - .003	.002 - .004
Lower Carbon Tool Steel Ex. P-20, H-13, S-7	300 - 500	.002 - .003	.002 - .004
Tool Steel Ex. A-2, A-6, D-2, M-2	300 - 500	.001 - .003	.001 - .004
Stainless Steel Ex. 304, 316, 420, 15-5PH, 17-4PH	300 - 500	.001 - .003	.001 - .003
Iron Ex. Cast, Ductile, Nodular	400 - 800	.002 - .005	.002 - .006
Nickel & Titanium Alloy Ex. Inconel, Hastelloy, Ti-6AL-4V	100 - 200	.001 - .002	.001 - .002
Non-Ferrous Metal Ex. Aluminum, Bronze, Brass	800 - 1200	.003 - .006	.003 - .008

Counterbore Tools



Applications

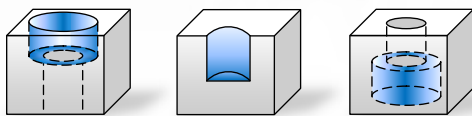

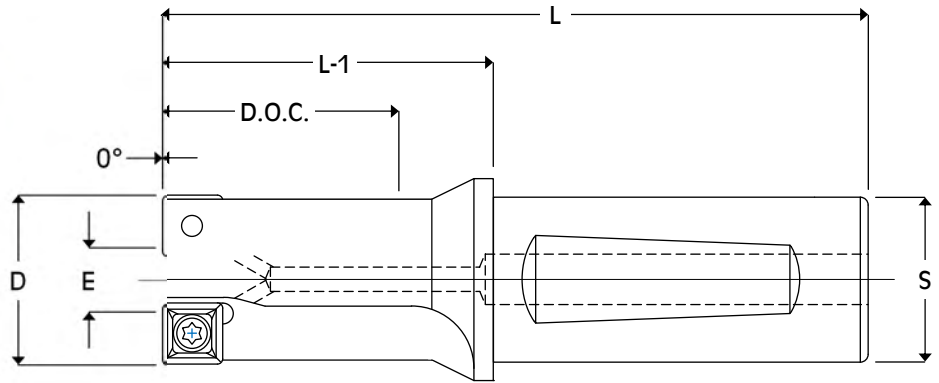

Tool Info.

Tool #	S.H.C.S. Size	Flutes	D	E	L	L-1	D.O.C	S	Insert	Screw	Wrench
CBN-500	5/16	2	.500	.180	2.812	1.062	.625	.500	SPEB-1511CB	164T	T-6
CBN-594	3/8	2	.594	.150	3.375	1.375	.750	.750	SPEB-221CB	300T	T-8
CBN-687	7/16	2	.687	.240	3.500	1.500	.875	.750	SPEB-221CB	314T	
CBN-781	1/2	2	.781	.260	3.625	1.625	1.000	.750	SPEB-2522CB		
CBN-906	9/16	2	.906	.260	4.000	1.750	1.125	1.000	SPEB-332CB	538T	T-10
CBN-1000	5/8	2	1.000	.360	4.125	1.875	1.250	1.000			
CBN-1187	3/4	2	1.187	.290	4.500	2.250	1.500	1.000	SPEB-432CB	638T	T-15
CBN-1375	7/8	2	1.375	.480	4.750	2.500	1.750	1.000			
CBN-1625	1"	2	1.625	.480	5.000	2.750	2.000	1.000	SPEB-532CB	838T	T-20

Chipbreaker Inserts

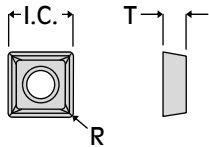

Insert Info.

Insert #	I.C.	T	R	Grades
SPEB-1511CB	.187	.082	.015	X33 X40
SPEB-221CB	.250	.125	.015	X33 X40
SPEB-2522CB	.312	.125	.031	X33 X40
SPEB-332CB	.375	.187	.031	X33 X40
SPEB-432CB	.500	.187	.031	X33 X40
SPEB-532CB	.625	.187	.031	X33

Speed and Feed Info.

Material	S.F.M.	.500 Dia. I.P.T.	.594 - .781 Dia. I.P.T.	.906 - 1.625 Dia. I.P.T.
Mild & Low Carbon Steel Ex. 1018, 1020, 1117, 1141, 12L14	800 - 1200	.001 - .003	.002 - .004	.003 - .005
High Carbon & Alloy Steel Ex. 1045, 4140, 4340, 52100, 8620	500 - 800	.001 - .003	.002 - .003	.003 - .005
Lower Carbon Tool Steel Ex. P-20, H-13, S-7	400 - 700	.001 - .003	.002 - .003	.003 - .005
Tool Steel Ex. A-2, A-6, D-2, M-2	300 - 600	.001 - .003	.001 - .003	.002 - .004
Stainless Steel Ex. 304, 316, 420, 15-5PH, 17-4PH	300 - 600	.001 - .003	.001 - .003	.002 - .004
Iron Ex. Cast, Ductile, Nodular	600 - 1000	.002 - .005	.002 - .005	.003 - .006
Nickel & Titanium Alloy Ex. Inconel, Hastelloy, Ti-6AL-4V	120 - 180	.001 - .002	.001 - .002	.002 - .003
Non-Ferrous Metal Ex. Aluminum, Bronze, Brass	1000 - 2500	.003 - .006	.003 - .006	.004 - .008

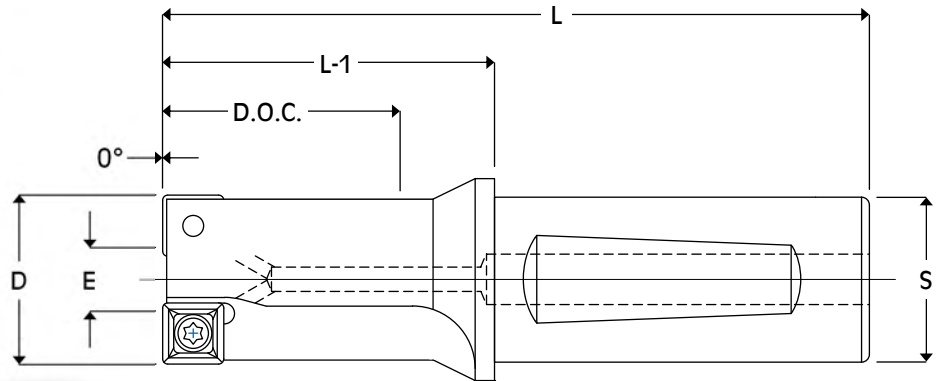

Tool Info.

Tool #	S.H.C.S. Size	Flutes	D	E	L	L-1	D.O.C	S	Insert	Screw	Wrench
CBN-11MM	M-6	2	.433	.120	2.750	1.000	.563	.500	SPEB-1511CB	164T	T-6
CBN-15MM	M-8	2	.590	.150	3.250	1.250	.625	.750	SPEB-221CB	300T	T-8
CBN-18MM	M-10	2	.709	.188	3.500	1.500	.875	.750	SPEB-2522CB	314T	
CBN-20MM	M-12	2	.787	.250	3.625	1.625	.937	.750	SPEB-332CB	538T	T-10
CBN-24MM	M-14	2	.945	.290	4.000	1.750	1.156	1.000			
CBN-26MM	M-16	2	1.024	.370	4.250	2.000	1.375	1.000	SPEB-432CB	638T	T-15
CBN-29MM	M-18	2	1.142	.240	4.500	2.250	1.562	1.000			
CBN-33MM	M-20	2	1.299	.390	4.625	2.375	1.625	1.000	SPEB-532CB	838T	T-20
CBN-38MM	M-24	2	1.496	.350	5.000	2.750	2.000	1.000			
CBN-48MM	M-30	2	1.890	.490	5.375	3.125	2.375	1.000	SPEB-6352CB	1012T	T-25

Chipbreaker Inserts

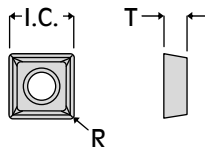

Insert Info.

Insert #	I.C.	T	R	Grades
SPEB-1511CB	.187	.082	.015	X33 X40
SPEB-221CB	.250	.125	.015	X33 X40
SPEB-2522CB	.312	.125	.031	X33 X40
SPEB-332CB	.375	.187	.031	X33 X40
SPEB-432CB	.500	.187	.031	X33 X40
SPEB-532CB	.625	.187	.031	X33
SPEB-6352CB	.750	.220	.031	X33 X40

Speed and Feed Info.

Material	S.F.M.	.433 Dia. I.P.T.	.590 - .787 Dia. I.P.T.	.945 - 1.890 Dia. I.P.T.
Mild & Low Carbon Steel Ex. 1018, 1020, 1117, 1141, 12L14	800 - 1200	.001 - .003	.002 - .004	.003 - .005
High Carbon & Alloy Steel Ex. 1045, 4140, 4340, 52100, 8620	500 - 800	.001 - .003	.002 - .003	.003 - .005
Lower Carbon Tool Steel Ex. P-20, H-13, S-7	400 - 700	.001 - .003	.002 - .003	.003 - .005
Tool Steel Ex. A-2, A-6, D-2, M-2	300 - 600	.001 - .003	.001 - .003	.002 - .004
Stainless Steel Ex. 304, 316, 420, 15-5PH, 17-4PH	300 - 600	.001 - .003	.001 - .003	.002 - .004
Iron Ex. Cast, Ductile, Nodular	600 - 1000	.002 - .005	.002 - .005	.003 - .006
Nickel & Titanium Alloy Ex. Inconel, Hastelloy, Ti-6AL-4V	120 - 180	.001 - .002	.001 - .002	.002 - .003
Non-Ferrous Metal Ex. Aluminum, Bronze, Brass	1000 - 2500	.003 - .006	.003 - .006	.004 - .008

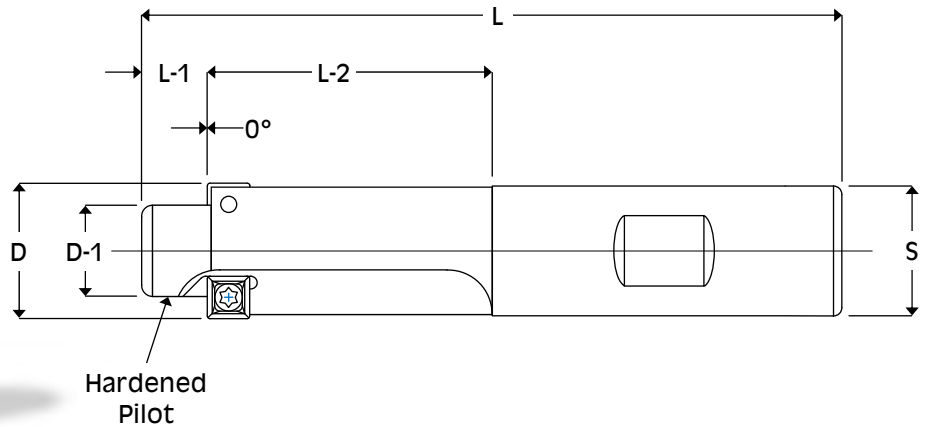

Tool Info.

Tool #	S.H.C.S. Size	Flutes	D	D-1	L	L-1	L-2	S	Insert	Screw	Wrench
CB-359	#10	1	.359	.215	3.250	.250	1.000	.500	SDEB-1511CB	164T	T-6
CB-406	1/4	1	.406	.280	3.250	.250	1.000	.500	SPEB-221CB	300T	T-8
CB-500	5/16	1	.500	.342	3.500	.312	1.187	.500			
CB-594	3/8	2	.594	.405	3.625	.312	1.312	.500			
CB-687	7/16	2	.687	.467	3.750	.375	1.375	.500			
CB-781	1/2	2	.781	.530	4.000	.375	1.625	.750	SPEB-221CB	314T	T-8
CB-1000	5/8	2	1.000	.655	4.125	.500	1.625	.750			
CB-1187	3/4	2	1.187	.812	4.250	.500	1.750	.750			

Speed and Feed Info.

Material	S.F.M.	.359 - .500 Dia. I.P.T.	.594 - 1.187 Dia. I.P.T.
Mild & Low Carbon Steel Ex. 1018, 1020, 1117, 1141, 12L14	800 - 1200	.001 - .002	.002 - .003
High Carbon & Alloy Steel Ex. 1045, 4140, 4340, 52100, 8620	500 - 800	.001 - .002	.002 - .003
Lower Carbon Tool Steel Ex. P-20, H-13, S-7	400 - 700	.001 - .002	.002 - .003
Tool Steel Ex. A-2, A-6, D-2, M-2	300 - 600	.001 - .002	.002 - .003
Stainless Steel Ex. 304, 316, 420, 15-5PH, 17-4PH	300 - 600	.001 - .002	.002 - .003
Iron Ex. Cast, Ductile, Nodular	600 - 1000	.001 - .002	.002 - .003
Nickel & Titanium Alloy Ex. Inconel, Hastelloy, TI-6AL-4V	120 - 180	.001 - .002	.001 - .002
Non-Ferrous Metal Ex. Aluminum, Bronze, Brass	1000 - 2500	.001 - .002	.002 - .003

Chipbreaker Inserts

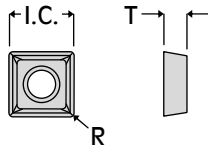

Insert Info.

Insert #	I.C.	T	R	Grades
SDEB-1511CB	.187	.082	.015	X33
SPEB-221CB	.250	.125	.015	X33 X40

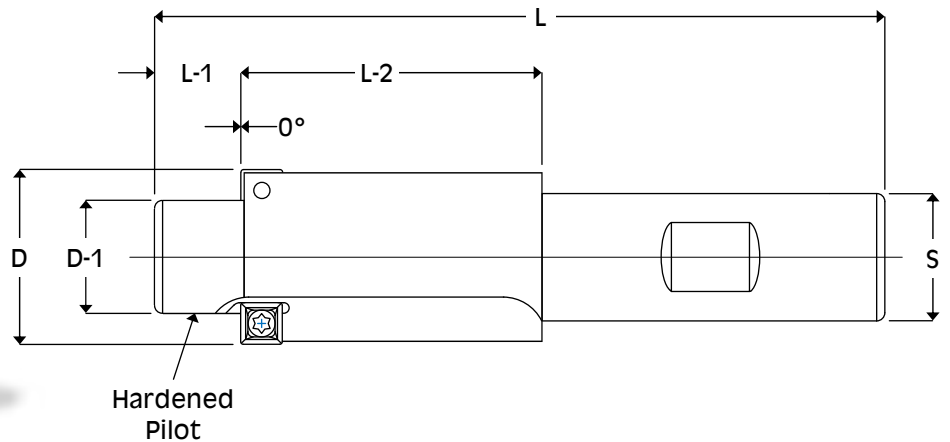

Tool Info.

Tool #	S.H.C.S. Size	Flutes	D	D-1	L	L-1	L-2	S	Insert	Screw	Wrench
CB-11MM	M-6	1	.433	.258	3.250	.250	1.000	.500	SPEB-221CB	300T	T-8
CB-15MM	M-8	2	.590	.352	3.625	.312	1.312	.500			
CB-18MM	M-10	2	.709	.431	3.750	.375	1.375	.500			
CB-20MM	M-12	2	.787	.549	4.000	.375	1.625	.750	SPEB-221CB	314T	T-8
CB-24MM	M-14	2	.945	.588	4.125	.500	1.625	.750			
CB-26MM	M-16	2	1.023	.667	4.250	.500	1.750	.750			
CB-33MM	M-20	2	1.298	.824	4.250	.500	1.750	.750			

Speed and Feed Info.

Material	S.F.M.	.433 Dia. I.P.T.	.590 - 1.298 Dia. I.P.T.
Mild & Low Carbon Steel Ex. 1018, 1020, 1117, 1141, 12L14	800 - 1200	.001 - .002	.002 - .003
High Carbon & Alloy Steel Ex. 1045, 4140, 4340, 52100, 8620	500 - 800	.001 - .002	.002 - .003
Lower Carbon Tool Steel Ex. P-20, H-13, S-7	400 - 700	.001 - .002	.002 - .003
Tool Steel Ex. A-2, A-6, D-2, M-2	300 - 600	.001 - .002	.002 - .003
Stainless Steel Ex. 304, 316, 420, 15-5PH, 17-4PH	300 - 600	.001 - .002	.002 - .003
Iron Ex. Cast, Ductile, Nodular	600 - 1000	.001 - .002	.002 - .003
Nickel & Titanium Alloy Ex. Inconel, Hastelloy, Ti-6AL-4V	120 - 180	.001 - .002	.001 - .002
Non-Ferrous Metal Ex. Aluminum, Bronze, Brass	1000 - 2500	.001 - .002	.002 - .003

Chipbreaker Insert

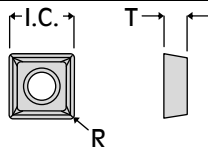

Insert Info.

Insert #	I.C.	T	R	Grades
SPEB-221CB	.250	.125	.015	X33 X40

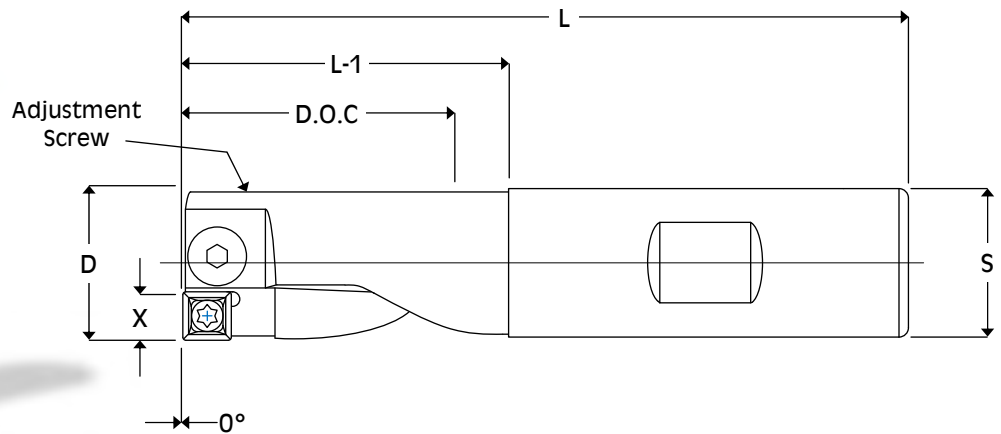

.600 - .750 Dia. Tool Info.

Tool #	D	Flutes	X	L	L-1	D.O.C.	S
CH-600-750	.600 to .750	1	.172	3.500	1.500	1.250	.750
Cartridge	Cartridge Screw	Adjustment Screw	Insert	Insert Screw	Wrench		
CH-1511	#63212	5-40 x 1/4	SPEB-1511CB	164T	T-6		

.750 - .937 Dia. Tool Info.

Tool #	D	Flutes	X	L	L-1	D.O.C.	S
CH-750-937	.750 to .937	1	.235	3.750	1.750	1.375	.750
Cartridge	Cartridge Screw	Adjustment Screw	Insert	Insert Screw	Wrench		
CH-221	#103262	5-40 x 1/4	SPEB-221CB	300T	T-8		

Chipbreaker Inserts

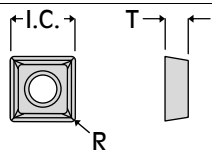

Insert Info.

Insert #	I.C.	T	R	Grades
SPEB-1511CB	.187	.082	.015	X33 X40
SPEB-221CB	.250	.125	.015	X33 X40

Speed and Feed Info.

Material	S.F.M.	I.P.R.
Mild & Low Carbon Steel Ex. 1018, 1020, 1117, 1141, 12L14	800 - 1200	.002 - .003
High Carbon & Alloy Steel Ex. 1045, 4140, 4340, 52100, 8620	500 - 800	.002 - .003
Lower Carbon Tool Steel Ex. P-20, H-13, S-7	400 - 700	.002 - .003
Tool Steel Ex. A-2, A-6, D-2, M-2	300 - 600	.001 - .003
Stainless Steel Ex. 304, 316, 420, 15-5PH, 17-4PH	300 - 600	.001 - .002
Iron Ex. Cast, Ductile, Nodular	600 - 1000	.002 - .003
Nickel & Titanium Alloy Ex. Inconel, Hastelloy, Ti-6AL-4V	120 - 180	.001 - .002
Non-Ferrous Metal Ex. Aluminum, Bronze, Brass	1000 - 2500	.002 - .004

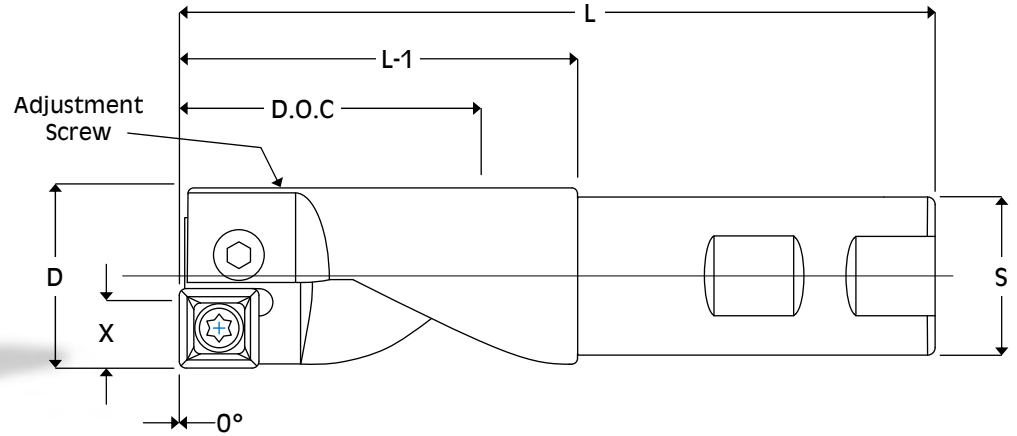

.937 - 1.187 Dia. Tool Info.

Tool #	D	Flutes	X	L	L-1	D.O.C.	S
CH-937-1187	.937 to 1.187	1	.280	4.500	2.250	1.875	1.000

Cartridge	Cartridge Screw	Adjustment Screw	Insert	Insert Screw	Wrench
CH-2522	#103262	5-40 x 1/4	SPEB-2522CB	300T	T-8

1.187 - 1.437 Dia. Tool Info.

Tool #	D	Flutes	X	L	L-1	D.O.C.	S
CH-1187-1437	1.187 to 1.437	1	.465	4.500	2.250	1.875	1.000

Cartridge	Cartridge Screw	Adjustment Screw	Insert	Insert Screw	Wrench
CH-432	#142878	6-32 x 1/4	SPEB-432CB	638T	T-15

1.437 - 1.687 Dia. Tool Info.

Tool #	D	Flutes	X	L	L-1	D.O.C.	S
CH-1437-1687	1.437 to 1.687	1	.465	4.500	2.250	1.875	1.000

Cartridge	Cartridge Screw	Adjustment Screw	Insert	Insert Screw	Wrench
CH-432	#142810	6-32 x 3/8	SPEB-432CB	638T	T-15

Chipbreaker Inserts				
Insert Info.				
Insert #	I.C.	T	R	Grades
SPEB-2522CB	.312	.125	.031	X33 X40
SPEB-432CB	.500	.187	.031	X33 X40

Speed and Feed Info.		
Material	S.F.M.	I.P.R.
Mild & Low Carbon Steel Ex. 1018, 1020, 1117, 1141, 12L14	800 - 1200	.002 - .003
High Carbon & Alloy Steel Ex. 1045, 4140, 4340, 52100, 8620	500 - 800	.002 - .003
Lower Carbon Tool Steel Ex. P-20, H-13, S-7	400 - 700	.002 - .003
Tool Steel Ex. A-2, A-6, D-2, M-2	300 - 600	.001 - .003
Stainless Steel Ex. 304, 316, 420, 15-5PH, 17-4PH	300 - 600	.001 - .002
Iron Ex. Cast, Ductile, Nodular	600 - 1000	.002 - .003
Nickel & Titanium Alloy Ex. Inconel, Hastelloy, Ti-6AL-4V	120 - 180	.001 - .002
Non-Ferrous Metal Ex. Aluminum, Bronze, Brass	1000 - 2500	.002 - .004

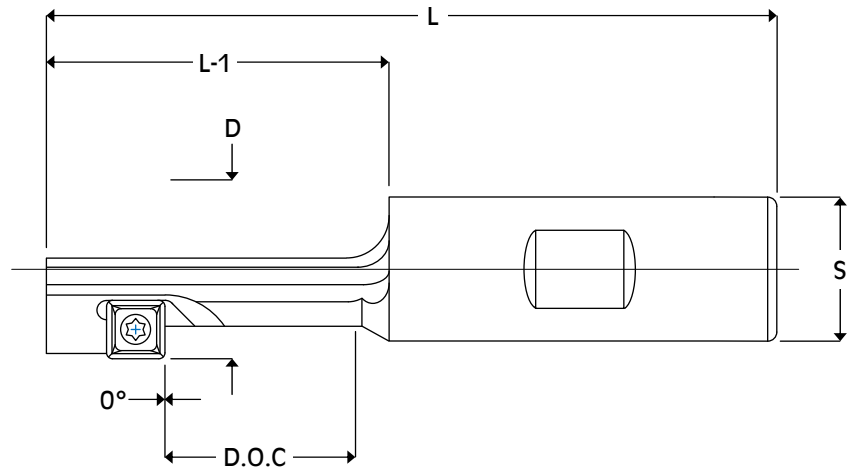

Tool Info.

Tool #	S.H.C.S. Size	Flutes	D	L	L-1	D.O.C	S	Insert	Screw	Wrench
BCB-500	5/16	1	.500	2.937	1.187	.750	.500	SPEB-1511CB	164T	T-6
BCB-594	3/8	1	.594	2.937	1.187	.750	.500			
BCB-687	7/16	1	.687	3.625	1.625	1.000	.750	SPEB-221CB	300T	T-8
BCB-781	1/2	1	.781	3.812	1.812	1.250	.750	SPEB-221CB	314T	T-8
BCB-1000	5/8	1	1.000	4.562	2.312	1.625	1.000			
BCB-1187	3/4	1	1.187	4.812	2.562	1.937	1.000			

Tool #	Min. Existing Hole Dia.	Offset to Enter Hole
BCB-500	.320	.100
BCB-594	.390	.110
BCB-687	.450	.120

Tool #	Min. Existing Hole Dia.	Offset to Enter Hole
BCB-781	.510	.135
BCB-1000	.640	.180
BCB-1187	.800	.195

Speed and Feed Info.

Material	S.F.M.	I.P.R.
Mild & Low Carbon Steel Ex. 1018, 1020, 1117, 1141, 12L14	800 - 1200	.002 - .003
High Carbon & Alloy Steel Ex. 1045, 4140, 4340, 52100, 8620	500 - 800	.002 - .003
Lower Carbon Tool Steel Ex. P-20, H-13, S-7	400 - 700	.002 - .003
Tool Steel Ex. A-2, A-6, D-2, M-2	300 - 600	.001 - .003
Stainless Steel Ex. 304, 316, 420, 15-5PH, 17-4PH	300 - 600	.002 - .003
Iron Ex. Cast, Ductile, Nodular	600 - 1000	.002 - .003
Nickel & Titanium Alloy Ex. Inconel, Hastelloy, Ti-6AL-4V	120 - 180	.001 - .002
Non-Ferrous Metal Ex. Aluminum, Bronze, Brass	1000 - 2500	.002 - .003

Chipbreaker Inserts

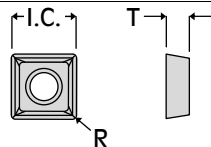

Insert Info.

Insert #	I.C.	T	R	Grades
SPEB-1511CB	.187	.082	.015	X33 X40
SPEB-221CB	.250	.125	.015	X33 X40

Octa-Mills

Available Modifications

- Reduce Shank Diameters
- Coolant Thru

2 - 3 Day Delivery



Applications

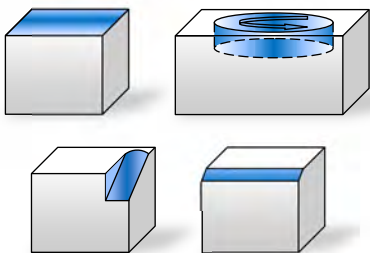

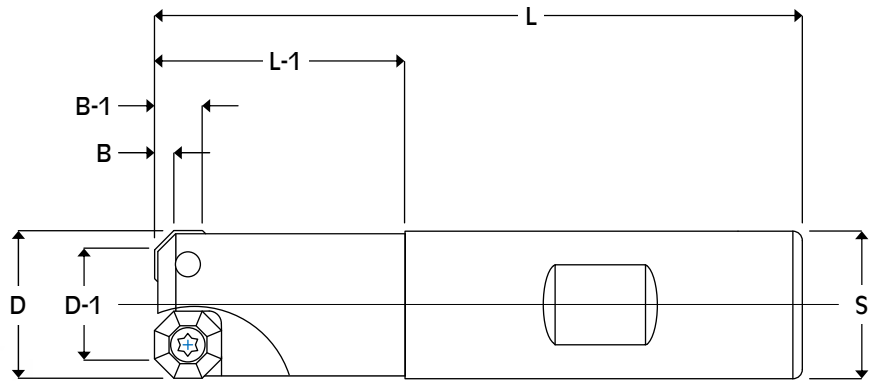

Tool Info.

Tool #	D	D-1	B	B-1	Flutes	L	L-1	S	Ramp	Insert
OC-500	.500	.310	.095	.220	1	3.000	1.000	.625	Drill*	ODEB-2711
OC-625	.625	.435	.095	.220	1	3.000	1.000	.625	Drill*	RDEB-2711
OC-750	.750	.560	.095	.220	2	3.250	1.250	.750	25°	ODEB-2721 RDEB-2721
XOC-750	.750	.560	.095	.220	2	5.000	3.000	.750	25°	
OC-875	.875	.685	.095	.220	2	3.250	1.250	.750	15°	
OC-1000	1.000	.810	.095	.220	3	3.500	1.500	.750	10°	
XOC-1000	1.000	.810	.095	.220	3	6.250	4.000	1.000	10°	
OC-1250	1.250	1.062	.095	.220	3	3.500	1.500	.750	8°	
OC-1540	1.500	1.312	.095	.220	4	3.500	1.500	.750	6°	

* Applies to ODEB inserts only.

Octa Positive Top Inserts

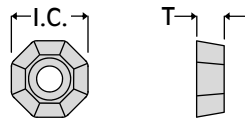

Insert Info.

Insert #	I.C.	T	Screw	Wrench	Grades
ODEB-2711	.343	.110	5625T	T-10	X33
ODEB-2721	.343	.130	5625T	T-10	BIM X33

Round Positive Top Inserts

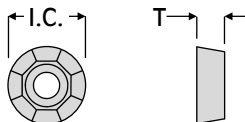

Insert Info.

Insert #	I.C.	T	Screw	Wrench	Grade
RDEB-2711	.343	.110	5625T	T-10	X33
RDEB-2721	.343	.130	5625T	T-10	

Speed and Feed Info.

Material	S.F.M.	.500 - .750 Dia. I.P.T.	.875 - 1.500 Dia. I.P.T.
Mild & Low Carbon Steel Ex. 1018, 1020, 1117, 1141, 12L14	800 - 1200	.002 - .005	.003 - .012
High Carbon & Alloy Steel Ex. 1045, 4140, 4340, 52100, 8620	500 - 800	.002 - .004	.003 - .010
Lower Carbon Tool Steel Ex. P-20, H-13, S-7	400 - 700	.002 - .004	.003 - .010
Tool Steel Ex. A-2, A-6, D-2, M-2	300 - 600	.002 - .004	.003 - .010
Stainless Steel Ex. 304, 316, 420, 15-5PH, 17-4PH	300 - 600	.002 - .003	.002 - .007
Iron Ex. Cast, Ductile, Nodular	600 - 1000	.003 - .006	.004 - .012
Nickel & Titanium Alloy Ex. Inconel, Hastelloy, Ti-6AL-4V	120 - 180	.001 - .003	.001 - .004
Non-Ferrous Metal Ex. Aluminum, Bronze, Brass	1000 - 2500	.003 - .006	.004 - .014

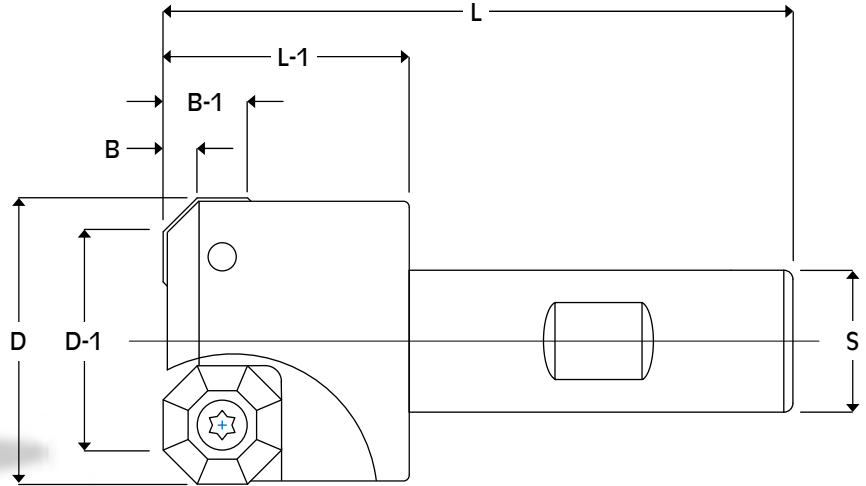

Tool Info.

Tool #	D	D-1	B	B-1	Flutes	L	L-1	S	Ramp	Insert
OC-1575	1.500	1.125	.160	.410	2	3.250	1.250	.750	20°	OPEB-535 RPEB-535
OC-1510	1.500	1.125	.160	.410	2	4.500	1.500	1.000	20°	
XOC-1500	1.500	1.125	.160	.410	2	8.250	6.000	1.250	20°	
OC-2075	2.000	1.625	.160	.410	3	3.250	1.250	.750	10°	
OC-2010	2.000	1.625	.160	.410	3	4.500	1.500	1.000	10°	

For Larger Diameters, Refer to Universal Mills on Page 133

Octa Positive Top Inserts		I.C.	T			
Insert Info.						
Insert #	I.C.	T	Screw	Wrench	Grades	
OPEB-535	.625	.220	838T	T-20	A9M X33	
OPEB-535XP	.625	.220	838T	T-20	B1M X40	

Round Positive Top Insert		I.C.	T			
Insert Info.						
Insert #	I.C.	T	Screw	Wrench	Grade	
RPEB-535	.625	.220	838T	T-20	X33	

Speed and Feed Info.

Material	S.F.M.	I.P.T.
Mild & Low Carbon Steel Ex. 1018, 1020, 1117, 1141, 12L14	800 - 1200	.003 - .012
High Carbon & Alloy Steel Ex. 1045, 4140, 4340, 52100, 8620	500 - 800	.003 - .010
Lower Carbon Tool Steel Ex. P-20, H-13, S-7	400 - 700	.003 - .010
Tool Steel Ex. A-2, A-6, D-2, M-2	300 - 600	.003 - .010
Stainless Steel Ex. 304, 316, 420, 15-5PH, 17-4PH	300 - 600	.002 - .007
Iron Ex. Cast, Ductile, Nodular	600 - 1000	.004 - .012
Nickel & Titanium Alloy Ex. Inconel, Hastelloy, Ti-6AL-4V	120 - 180	.001 - .004
Non-Ferrous Metal Ex. Aluminum, Bronze, Brass	1000 - 2500	.004 - .014

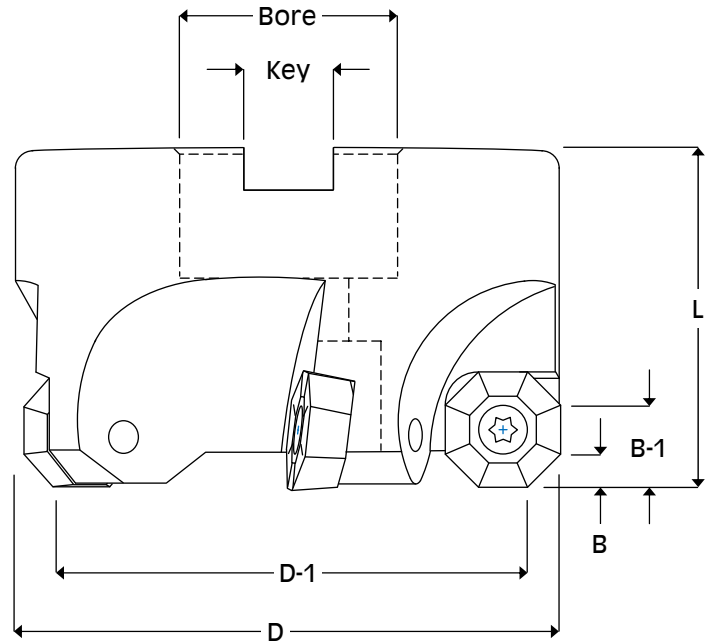

Tool Info.

Tool #	D	D-1	B	B-1	L	Flutes	Bore	Key	Ramp	Insert
OC-2000	2.000	1.625	.160	.410	1.750	3	.750	.312	10°	OPEB-535 RPEB-535
OC-2500	2.500	2.125	.160	.410	1.750	4	1.000	.375	7°	
OC-3000	3.000	2.625	.160	.410	1.750	5	1.000	.375	5°	
OC-4000	4.000	3.625	.160	.410	1.750	6	1.500	.625	3°	
OC-5000	5.000	4.625	.160	.410	1.750	6	1.500	.625	2°	
OC-6000	6.000	5.625	.160	.410	1.750	7	1.500	.625	1°	

For Larger Diameters, Refer to Universal Mills on Page 133

Octa Positive Top Inserts			
<i>Insert Info.</i>			
Insert #	I.C.	T	Grades
OPEB-535	.625	.220	A9M X33
OPEB-535XP	.625	.220	B1M X40

Round Positive Top Insert			
<i>Insert Info.</i>			
Insert #	I.C.	T	Grade
RPEB-535	.625	.220	X33

Speed and Feed Info.

Material	S.F.M.	I.P.T.
Mild & Low Carbon Steel Ex. 1018, 1020, 1117, 1141, 12L14	800 - 1200	.003 - .012
High Carbon & Alloy Steel Ex. 1045, 4140, 4340, 52100, 8620	500 - 800	.003 - .010
Lower Carbon Tool Steel Ex. P-20, H-13, S-7	400 - 700	.003 - .010
Tool Steel Ex. A-2, A-6, D-2, M-2	300 - 600	.003 - .010
Stainless Steel Ex. 304, 316, 420, 15-5PH, 17-4PH	300 - 600	.002 - .007
Iron Ex. Cast, Ductile, Nodular	600 - 1000	.004 - .012
Nickel & Titanium Alloy Ex. Inconel, Hastelloy, Ti-6AL-4V	120 - 180	.001 - .004
Non-Ferrous Metal Ex. Aluminum, Bronze, Brass	1000 - 2500	.004 - .014

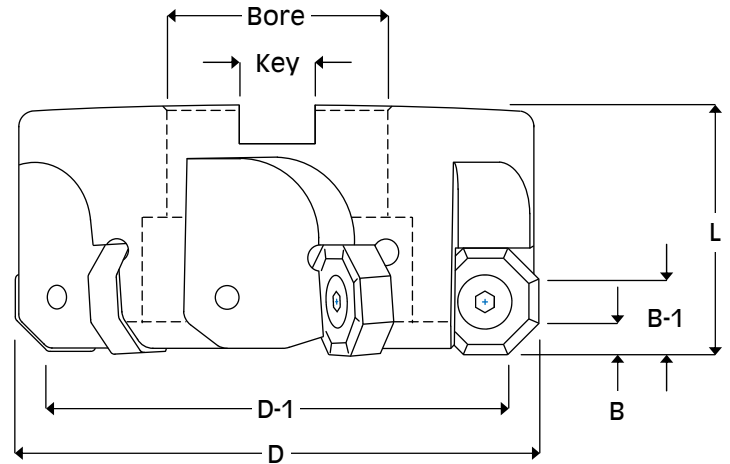

Tool Info.

Tool #	D	D-1	B	B-1	L	Flutes	Bore	Key	Insert
HDOC-3000	3.000	2.400	.300	.700	2.000	4	1.000	.375	ONMB-85 RNMB-85 ONEB-85P RNEB-85P
HDOC-4000	4.000	3.400	.300	.700	2.250	5	1.500	.625	
HDOC-5000	5.000	4.400	.300	.700	2.250	6	1.500	.625	
HDOC-6000	6.000	5.400	.300	.700	2.250	7	1.500	.625	
HDOC-8000	8.000	7.400	.300	.700	2.250	9	2.500	1.000	
HDOC-10000	10.000	9.400	.300	.700	2.250	11	2.500	1.000	
HDOC-12000	12.000	11.400	.300	.700	2.250	13	2.500	1.000	

Octa Positive Top (Double Sided)

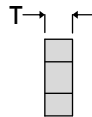
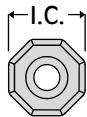

16 Edges!

Insert Info.

Insert #	I.C.	T	Screw	Wrench	Grade
ONMB-85	1.000	.312	1462T	T-532	A10M

Octa Positive Top (Single Sided)

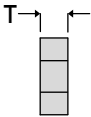
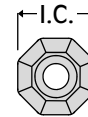

Insert Info.

Insert #	I.C.	T	Screw	Wrench	Grade
ONEB-85	1.000	.312	1462T	T-532	A10M

Round Positive Top (Double Sided)

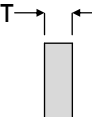
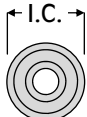

Insert Info.

Insert #	I.C.	T	Screw	Wrench	Grade
RNMB-85	1.000	.312	1462T	T-532	A10M

Round Positive Top (Single Sided)

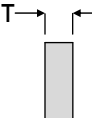
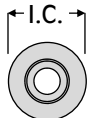

Insert Info.

Insert #	I.C.	T	Screw	Wrench	Grade
RNEB-85P	1.000	.312	1462T	T-532	A10M

Speed and Feed Info.

Material	S.F.M.	I.P.T.
Mild & Low Carbon Steel Ex. 1018, 1020, 1117, 1141, 12L14	800 - 1200	.010 - .030
High Carbon & Alloy Steel Ex. 1045, 4140, 4340, 52100, 8620	500 - 800	.008 - .020
Lower Carbon Tool Steel Ex. P-20, H-13, S-7	400 - 700	.008 - .020
Tool Steel Ex. A-2, A-6, D-2, M-2	300 - 600	.008 - .020
Stainless Steel Ex. 304, 316, 420, 15-5PH, 17-4PH	300 - 600	.006 - .016
Iron Ex. Cast, Ductile, Nodular	600 - 1000	.010 - .030
Nickel & Titanium Alloy Ex. Inconel, Hastelloy, Ti-6AL-4V	120 - 180	.004 - .008
Non-Ferrous Metal Ex. Aluminum, Bronze, Brass	1000 - 2500	.010 - .040

Dual Octa-Mills

Available Modifications

- Reduce Shank Diameters
- Coolant Thru

2 - 3 Day Delivery

Great tool for
Harder Materials

Strong Neutral
Cutting Edge

16 Cutting Edges
Per Insert

Available in a Shank Style
or Shell Mount Style

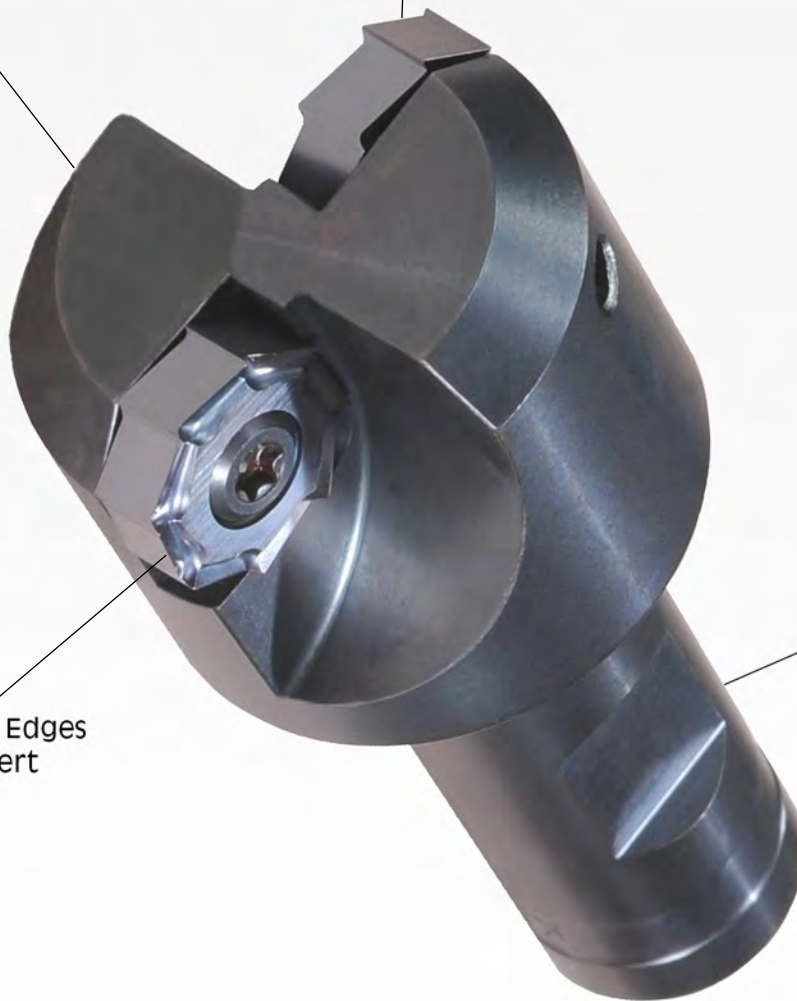

Applications

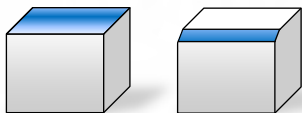

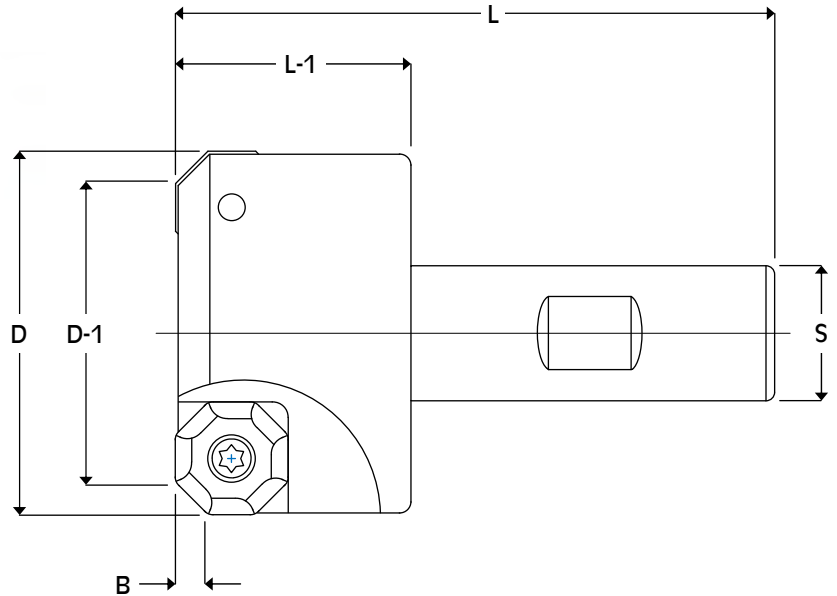

Tool Info.

Tool #	D	D-1	B	Flutes	L	L-1	S	Insert
DOC-1575	1.500	1.100	.150	2	3.250	1.250	.750	ONPG-4532
DOC-2075	2.000	1.600	.150	4	3.250	1.250	.750	
DOC-2010	2.000	1.600	.150	4	3.750	1.500	1.000	

I.C.

T

Insert Info.

ONPG-4532	
Grade	X33
I.C.	.593
T	.220
Screw	838T
Wrench	T-20

Speed and Feed Info.

Material	S.F.M.	I.P.T.
Mild & Low Carbon Steel <i>Ex. 1018, 1020, 1117, 1141, 12L14</i>	800 - 1200	.004 - .012
High Carbon & Alloy Steel <i>Ex. 1045, 4140, 4340, 52100, 8620</i>	500 - 800	.004 - .010
Lower Carbon Tool Steel <i>Ex. P-20, H-13, S-7</i>	400 - 700	.004 - .010
Tool Steel <i>Ex. A-2, A-6, D-2, M-2</i>	300 - 600	.004 - .010
Stainless Steel <i>Ex. 304, 316, 420, 15-5PH, 17-4PH</i>	300 - 600	.003 - .007
Iron <i>Ex. Cast, Ductile, Nodular</i>	600 - 1000	.005 - .012
Nickel & Titanium Alloy <i>Ex. Inconel, Hastelloy, Ti-6AL-4V</i>	120 - 180	.002 - .004
Non-Ferrous Metal <i>Ex. Aluminum, Bronze, Brass</i>	1000 - 2500	.005 - .014

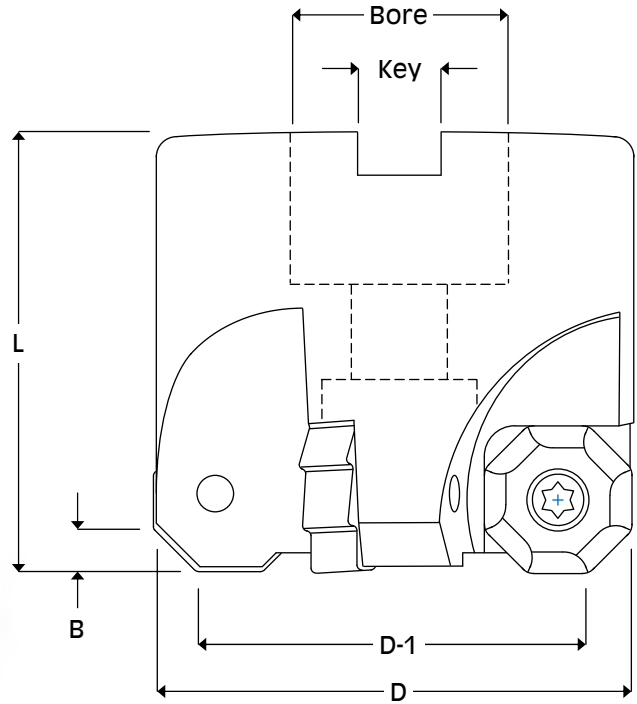

Tool Info.

Tool #	D	D-1	B	L	Flutes	Bore	Key	Insert
DOC-2000	2.000	1.600	.150	1.750	4	.750	.312	ONPG-4532
DOC-3000	3.000	2.600	.150	1.750	5	1.000	.375	
DOC-4000	4.000	3.600	.150	1.750	7	1.500	.625	
DOC-5000	5.000	4.600	.150	1.750	8	1.500	.625	
DOC-6000	6.000	5.600	.150	1.750	9	1.500	.625	

For Larger Diameters, Refer to Universal Mills on Page 133

Insert Info.	
ONPG-4532	
Grade	X33
I.C.	.593
T	.220
Screw	838T
Wrench	T-20

Speed and Feed Info.

Material	S.F.M.	I.P.T.
Mild & Low Carbon Steel Ex. 1018, 1020, 1117, 1141, 12L14	800 - 1200	.004 - .012
High Carbon & Alloy Steel Ex. 1045, 4140, 4340, 52100, 8620	500 - 800	.004 - .010
Lower Carbon Tool Steel Ex. P-20, H-13, S-7	400 - 700	.004 - .010
Tool Steel Ex. A-2, A-6, D-2, M-2	300 - 600	.004 - .010
Stainless Steel Ex. 304, 316, 420, 15-5PH, 17-4PH	300 - 600	.003 - .007
Iron Ex. Cast, Ductile, Nodular	600 - 1000	.005 - .012
Nickel & Titanium Alloy Ex. Inconel, Hastelloy, Ti-6AL-4V	120 - 180	.002 - .004
Non-Ferrous Metal Ex. Aluminum, Bronze, Brass	1000 - 2500	.005 - .014

Button Cutters

Available Modifications

- Reduce Shank Diameters
- Coolant Thru

2 - 3 Day Delivery

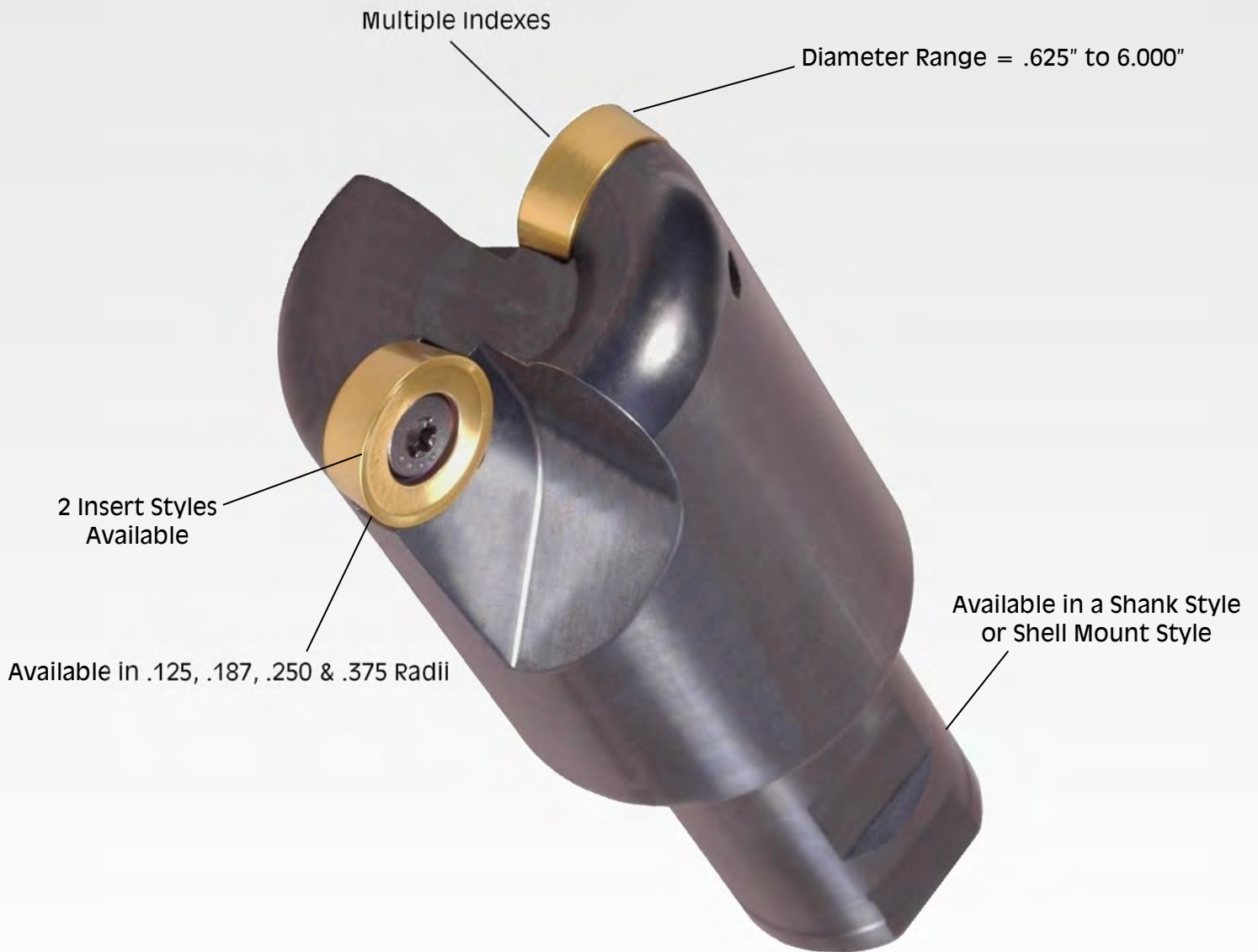

Applications

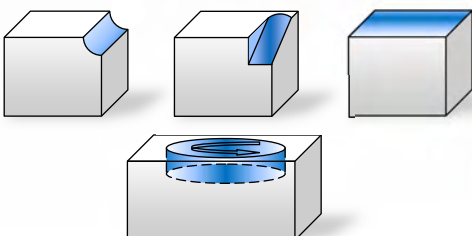

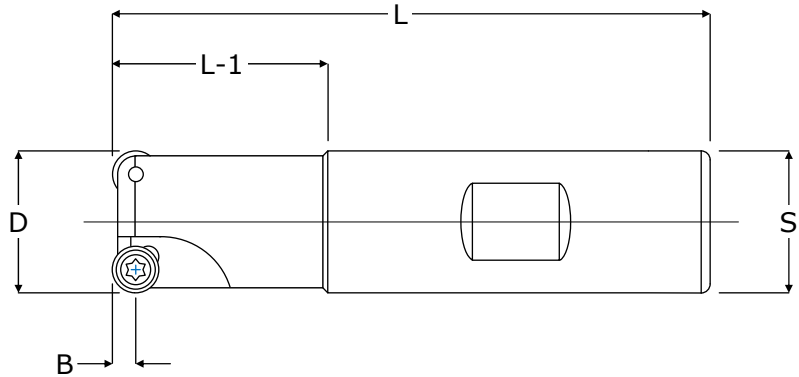

.250 I.C. Inserts

Tool Info.

Tool #	D	B	Flutes	L	L-1	S	Plunge	Ramp	Insert
BC2-625L	.625	.125	2	3.875	.970	.750	.015	3°	RCEB-22 RCEB-22G
BC2-750	.750	.125	2	3.125	1.125	.750	.020	3°	
BC2-750L	.750	.125	2	4.250	2.250	.750	.020	3°	
BC2-750XL	.750	.125	2	5.750	3.750	.750	.020	3°	
BC2-1000	1.000	.125	3	3.500	1.500	.750	.045	4°	
BC2-1000L	1.000	.125	2	5.250	3.000	1.000	.045	4°	
BC2-1000XL	1.000	.125	2	7.250	5.000	1.000	.045	4°	

Speed and Feed Info.

Material	S.F.M.	.625 - .750 Dia. I.P.T.	1.000 Dia. I.P.T.
Mild & Low Carbon Steel Ex. 1018, 1020, 1117, 1141, 12L14	800 - 1200	.002 - .005	.003 - .012
High Carbon & Alloy Steel Ex. 1045, 4140, 4340, 52100, 8620	500 - 800	.002 - .004	.003 - .010
Lower Carbon Tool Steel Ex. P-20, H-13, S-7	400 - 700	.002 - .004	.003 - .010
Tool Steel Ex. A-2, A-6, D-2, M-2	300 - 600	.002 - .004	.003 - .010
Stainless Steel Ex. 304, 316, 420, 15-5PH, 17-4PH	300 - 600	.002 - .003	.002 - .007
Iron Ex. Cast, Ductile, Nodular	600 - 1000	.003 - .006	.004 - .012
Nickel & Titanium Alloy Ex. Inconel, Hastelloy, Ti-6AL-4V	120 - 180	.001 - .003	.001 - .004
Non-Ferrous Metal Ex. Aluminum, Bronze, Brass	1000 - 2500	.003 - .006	.004 - .014



Insert Info.

Insert #	I.C.	T	Screw	Wrench	Grades
RCEB-22	.250	.125	314T	T-8	A10M X33
RCEB-22G	.250	.125	314T	T-8	B1M X33

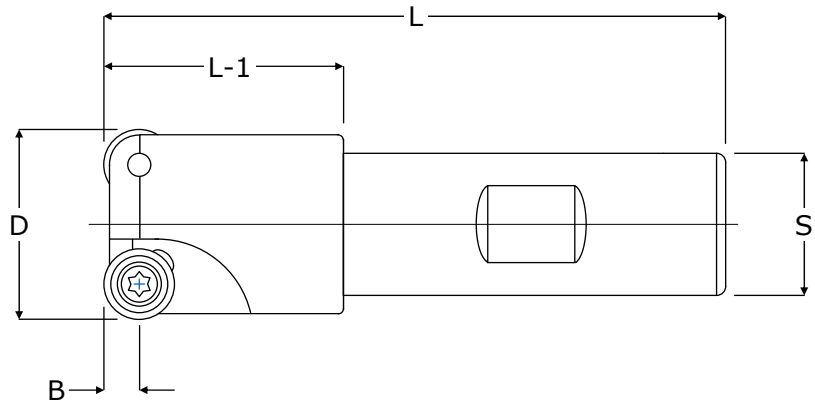

.375 I.C. Inserts

Tool Info.

Tool #	D	B	Flutes	L	L-1	S	Plunge	Ramp	Inserts
BC3-812	.812	.187	2	3.250	1.250	.750	.025	5°	RCEB-325 RCEB-325G
BC3-812L	.812	.187	2	4.750	2.500	1.000	.025	5°	
BC3-812XL	.812	.187	2	6.375	4.125	1.000	.025	5°	
BC3-1000	1.000	.187	2	3.500	1.500	.750	.040	5°	
BC3-1000L	1.000	.187	2	5.250	3.000	1.000	.040	5°	
BC3-1000XL	1.000	.187	2	7.250	5.000	1.000	.040	5°	
BC3-1500	1.500	.187	3	4.500	2.250	1.000	.065	4°	
BC3-1500L	1.500	.187	2	6.750	4.500	1.250	.065	4°	
BC3-1500XL	1.500	.187	2	10.187	7.500	1.500	.065	4°	

Speed and Feed Info.

Material	S.F.M.	I.P.T.
Mild & Low Carbon Steel Ex. 1018, 1020, 1117, 1141, 12L14	800 - 1200	.003 - .012
High Carbon & Alloy Steel Ex. 1045, 4140, 4340, 52100, 8620	500 - 800	.003 - .010
Lower Carbon Tool Steel Ex. P-20, H-13, S-7	400 - 700	.003 - .010
Tool Steel Ex. A-2, A-6, D-2, M-2	300 - 600	.003 - .010
Stainless Steel Ex. 304, 316, 420, 15-5PH, 17-4PH	300 - 600	.002 - .007
Iron Ex. Cast, Ductile, Nodular	600 - 1000	.004 - .012
Nickel & Titanium Alloy Ex. Inconel, Hastelloy, Ti-6AL-4V	120 - 180	.001 - .004
Non-Ferrous Metal Ex. Aluminum, Bronze, Brass	1000 - 2500	.004 - .014

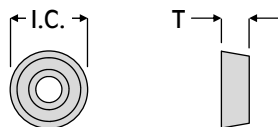

Insert Info.

Insert #	I.C.	T	Screw	Wrench	Grades
RCEB-325	.375	.156	538T	T-10	A10M X33
RCEB-325G	.375	.156	538T	T-10	B1M X33

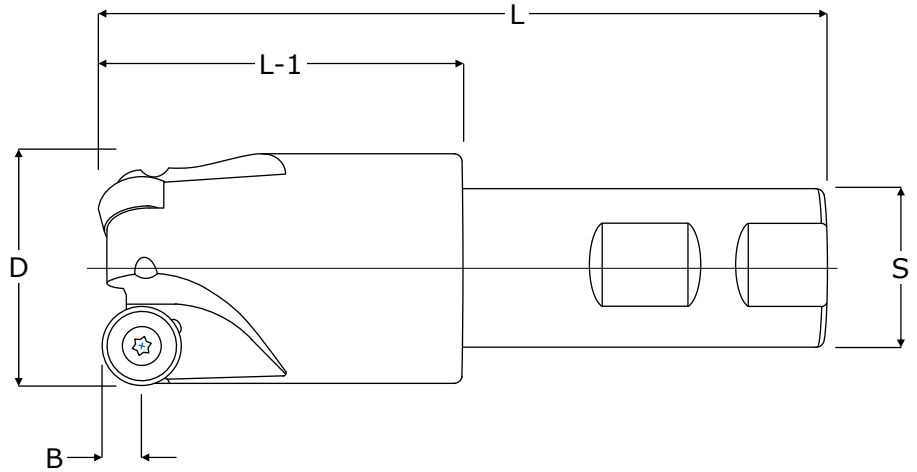

.500 I.C. Inserts

Tool Info.

Tool #	D	B	Flutes	L	L-1	S	Plunge	Ramp	Inserts
BC4-1125	1.125	.250	2	4.000	1.750	1.000	.055	7°	RCEB-435 RCEB-435G
BC4-1125L	1.125	.250	2	5.625	3.375	1.000	.055	7°	
BC4-1125XL	1.125	.250	2	7.875	5.625	1.000	.055	7°	
BC4-1500	1.500	.250	3	4.500	2.250	1.000	.070	5°	
BC4-1500L	1.500	.250	2	6.750	4.500	1.250	.070	5°	
BC4-1500XL	1.500	.250	2	10.187	7.500	1.500	.070	5°	

Speed and Feed Info.

Material	S.F.M.	I.P.T.
Mild & Low Carbon Steel Ex. 1018, 1020, 1117, 1141, 12L14	800 - 1200	.003 - .012
High Carbon & Alloy Steel Ex. 1045, 4140, 4340, 52100, 8620	500 - 800	.003 - .010
Lower Carbon Tool Steel Ex. P-20, H-13, S-7	400 - 700	.003 - .010
Tool Steel Ex. A-2, A-6, D-2, M-2	300 - 600	.003 - .010
Stainless Steel Ex. 304, 316, 420, 15-5PH, 17-4PH	300 - 600	.002 - .007
Iron Ex. Cast, Ductile, Nodular	600 - 1000	.004 - .012
Nickel & Titanium Alloy Ex. Inconel, Hastelloy, Ti-6AL-4V	120 - 180	.001 - .004
Non-Ferrous Metal Ex. Aluminum, Bronze, Brass	1000 - 2500	.004 - .014

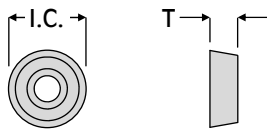

Insert Info.

Insert #	I.C.	T	Screw	Wrench	Grades
RCEB-435	.500	.220	838T	T-20	A10M X33
RCEB-435G	.500	.220	838T	T-20	B1M X33

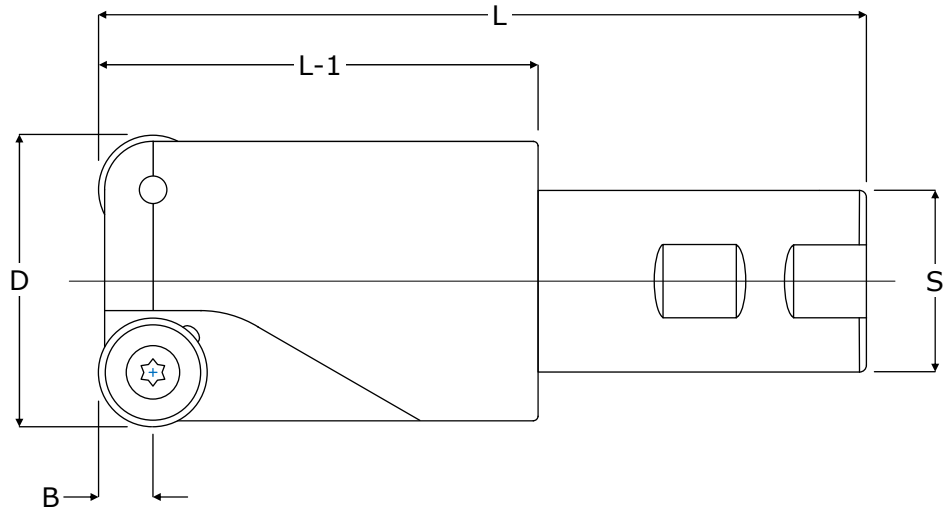

.750 I.C. Inserts

Tool Info.

Tool #	D	B	Flutes	L	L-1	S	Plunge	Ramp	Inserts
BC6-2000	2.000	.375	2	5.250	3.000	1.250	.120	7°	RCEB-64
BC6-2000L	2.000	.375	2	8.687	6.000	1.500	.120	7°	

Speed and Feed Info.

Material	S.F.M.	I.P.T.
Mild & Low Carbon Steel Ex. 1018, 1020, 1117, 1141, 12L14	800 - 1200	.003 - .012
High Carbon & Alloy Steel Ex. 1045, 4140, 4340, 52100, 8620	500 - 800	.003 - .010
Lower Carbon Tool Steel Ex. P-20, H-13, S-7	400 - 700	.003 - .010
Tool Steel Ex. A-2, A-6, D-2, M-2	300 - 600	.003 - .010
Stainless Steel Ex. 304, 316, 420, 15-5PH, 17-4PH	300 - 600	.002 - .007
Iron Ex. Cast, Ductile, Nodular	600 - 1000	.004 - .012
Nickel & Titanium Alloy Ex. Inconel, Hastelloy, TI-6AL-4V	120 - 180	.001 - .004
Non-Ferrous Metal Ex. Aluminum, Bronze, Brass	1000 - 2500	.004 - .014

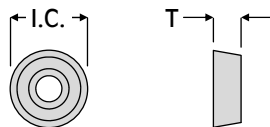

Insert Info.

Insert #	I.C.	T	Screw	Wrench	Grades
RCEB-64	.750	.250	1012T	T-25	A10M X33

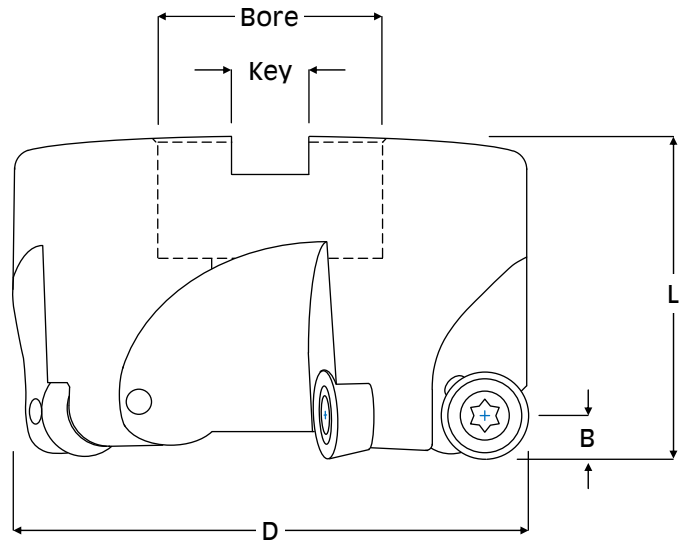

.375 I.C. Inserts

Tool Info.

Tool #	D	B	Flutes	L	Bore	Key	Plunge	Ramp	Inserts
BC3-2000	2.000	.187	5	1.750	.750	.312	.100	4°	RCEB-325 RCEB-325G

.500 I.C. Inserts

Tool Info.

Tool #	D	B	Flutes	L	Bore	Key	Plunge	Ramp	Inserts
BC4-2000	2.000	.250	4	1.750	.750	.312	.100	4°	RCEB-435 RCEB-435G
BC4-3000	3.000	.250	5	1.750	1.000	.375	.120	3°	
BC4-4000	4.000	.250	6	1.750	1.500	.625	.120	2°	

For Larger Diameters, Refer to Universal Mills on Page 133

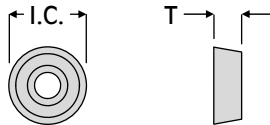

Insert Info.

Insert #	I.C.	T	Screw	Wrench	Grades
RCEB-325	.375	.156	538T	T-10	A10M X33
RCEB-325G	.375	.156	538T	T-10	B1M X33
RCEB-435	.500	.220	838T	T-20	A10M X33
RCEB-435G	.500	.220	838T	T-20	B1M X33

Speed and Feed Info.

Material	S.F.M.	I.P.T.
Mild & Low Carbon Steel Ex. 1018, 1020, 1117, 1141, 12L14	800 - 1200	.003 - .012
High Carbon & Alloy Steel Ex. 1045, 4140, 4340, 52100, 8620	500 - 800	.003 - .010
Lower Carbon Tool Steel Ex. P-20, H-13, S-7	400 - 700	.003 - .010
Tool Steel Ex. A-2, A-6, D-2, M-2	300 - 600	.003 - .010
Stainless Steel Ex. 304, 316, 420, 15-5PH, 17-4PH	300 - 600	.002 - .007
Iron Ex. Cast, Ductile, Nodular	600 - 1000	.004 - .012
Nickel & Titanium Alloy Ex. Inconel, Hastelloy, Ti-6AL-4V	120 - 180	.001 - .004
Non-Ferrous Metal Ex. Aluminum, Bronze, Brass	1000 - 2500	.004 - .014

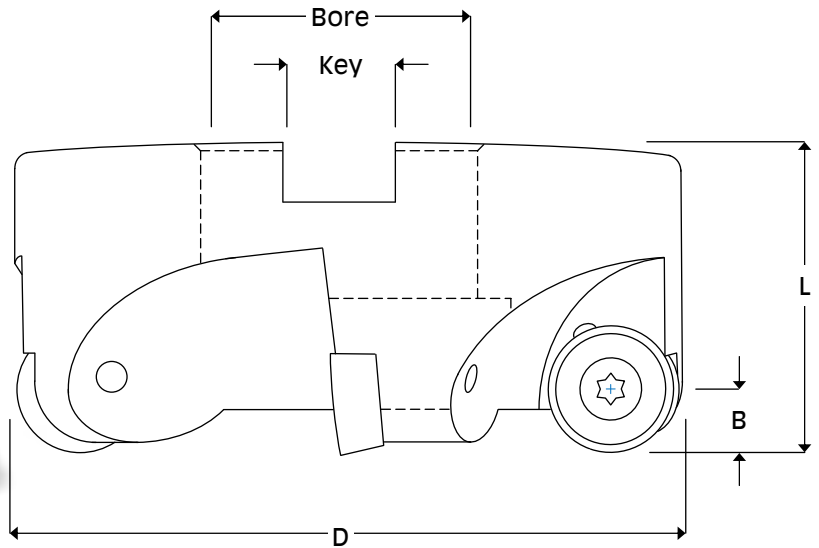

.750 I.C. Inserts

Tool Info.

Tool #	D	B	Flutes	L	Bore	Key	Plunge	Ramp	Inserts
BC6-4000	4.000	.375	5	1.750	1.500	.625	.210	4°	RCEB-64
BC6-5000	5.000	.375	6	1.750	1.500	.625	.210	3°	
BC6-6000	6.000	.375	6	1.750	1.500	.625	.210	2°	

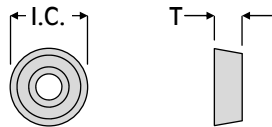

Insert Info.

Insert #	I.C.	T	Screw	Wrench	Grades
RCEB-64	.750	.250	1012T	T-25	A10M X33

Speed and Feed Info.

Material	S.F.M.	I.P.T.
Mild & Low Carbon Steel Ex. 1018, 1020, 1117, 1141, 12L14	800 - 1200	.003 - .012
High Carbon & Alloy Steel Ex. 1045, 4140, 4340, 52100, 8620	500 - 800	.003 - .010
Lower Carbon Tool Steel Ex. P-20, H-13, S-7	400 - 700	.003 - .010
Tool Steel Ex. A-2, A-6, D-2, M-2	300 - 600	.003 - .010
Stainless Steel Ex. 304, 316, 420, 15-5PH, 17-4PH	300 - 600	.002 - .007
Iron Ex. Cast, Ductile, Nodular	600 - 1000	.004 - .012
Nickel & Titanium Alloy Ex. Inconel, Hastelloy, Ti-6AL-4V	120 - 180	.001 - .004
Non-Ferrous Metal Ex. Aluminum, Bronze, Brass	1000 - 2500	.004 - .014

Chamfer Products

Available Modifications

- Reduce Shank Diameters
- Coolant Thru

2 - 3 Day Delivery

Long Edge Chamfer Mills Available

Multiple Angles

Extended Lengths Available

Available in a Shank Style
or Shell Mount Style

Adjustable / Cartridge Style Available

Reverse Chamfer Mills Available



Applications

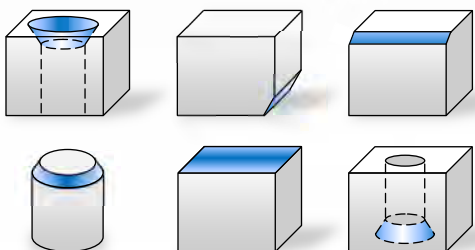

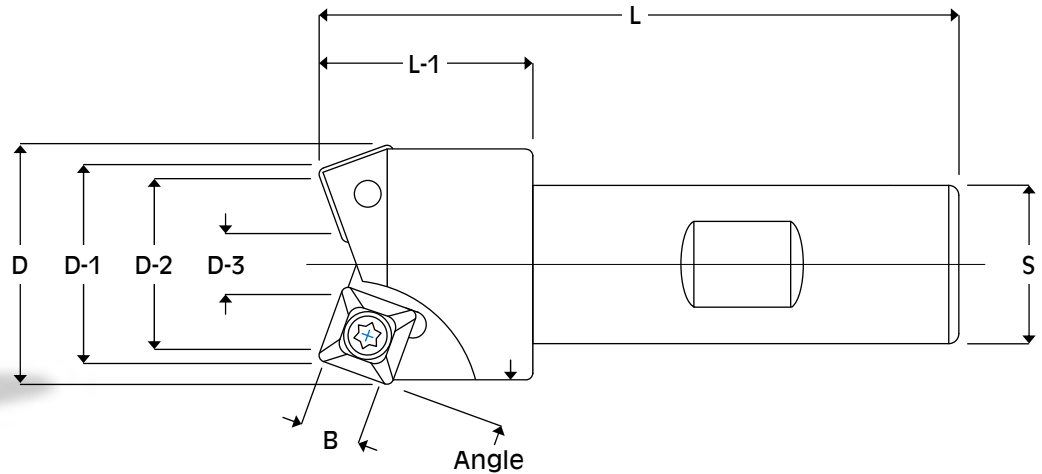

15° Chamfer Mills

Tool Info.

Tool #	Angle	Flutes	D	D-1	D-2	D-3	L	L-1	B	S	Screw	Wrench	Insert
A-5768	15°	2	.625	.560	N/A	N/A	2.500	.750	.156	.500	164T	T-6	SPEB-1511CB
A-5758	15°	2	1.125	.970	.875	.312	3.000	1.000	.312	.750	438T	T-10	SPEB-322P
A-5776	15°	2	1.625	1.410	1.300	.500	3.250	1.250	.438	.750	638T	T-15	SPEB-432PA
A-5762	15°	2	2.250	1.900	1.750	.500	3.750	1.500	.687	1.000	1012T	T-25	SPEB-6352PA

20° Chamfer Mills

Tool Info.

Tool #	Angle	Flutes	D	D-1	D-2	D-3	L	L-1	B	S	Screw	Wrench	Insert
A-5773	20°	2	.625	.525	N/A	N/A	2.500	.750	.156	.500	164T	T-6	SPEB-1511CB
A-5774	20°	2	1.125	.920	.812	.250	3.000	1.000	.312	.750	438T	T-10	SPEB-322P
A-5777	20°	2	1.625	1.340	1.220	.440	3.250	1.250	.438	.750	638T	T-15	SPEB-432PA
A-5775	20°	2	2.250	1.790	1.650	.438	3.750	1.500	.687	1.000	1012T	T-25	SPEB-6352PA

Chipbreaker Insert

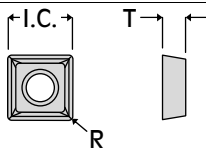

Insert Info.

Insert #	I.C.	T	R	Grades
SPEB-1511CB	.187	.082	.015	X33 X40

Positive Top Inserts

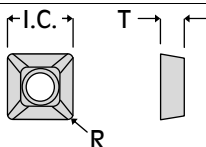

Insert Info.

Insert #	I.C.	T	R	Grades
SPEB-322P	.375	.125	.031	B1M A9M X33 X40
SPEB-432PA	.500	.187	.031	B1M A9M X33 X40
SPEB-6352PA	.750	.220	.031	X33 X40

Speed and Feed Info.

Material	S.F.M.	.625 Dia. I.P.T.	1.125 - 2.250 Dia. I.P.T.
Mild & Low Carbon Steel Ex. 1018, 1020, 1117, 1141, 12L14	800 - 1200	.002 - .003	.003 - .007
High Carbon & Alloy Steel Ex. 1045, 4140, 4340, 52100, 8620	500 - 800	.002 - .003	.002 - .006
Lower Carbon Tool Steel Ex. P-20, H-13, S-7	400 - 700	.002 - .003	.002 - .006
Tool Steel Ex. A-2, A-6, D-2, M-2	300 - 600	.001 - .003	.002 - .006
Stainless Steel Ex. 304, 316, 420, 15-5PH, 17-4PH	300 - 600	.002 - .003	.002 - .006
Iron Ex. Cast, Ductile, Nodular	600 - 1000	.002 - .003	.004 - .008
Nickel & Titanium Alloy Ex. Inconel, Hastelloy, Ti-6AL-4V	120 - 180	.001 - .002	.001 - .003
Non-Ferrous Metal Ex. Aluminum, Bronze, Brass	1000 - 2500	.002 - .003	.004 - .010

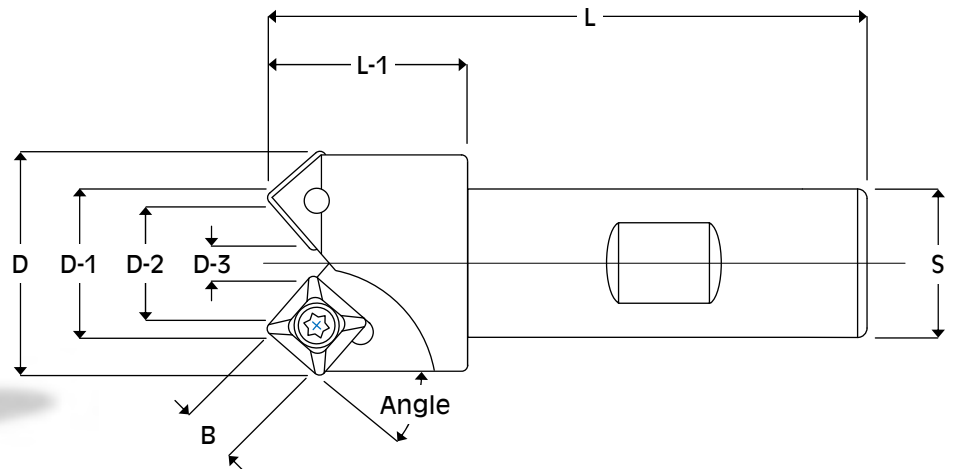

22.5° Chamfer Mills

Tool Info.

Tool #	Angle	Flutes	D	D-1	D-2	D-3	L	L-1	B	S	Screw	Wrench	Insert
A-2250	22.5°	2	1.625	1.300	1.190	.420	3.250	1.250	.438	.750	638T	T-15	SPEB-432PA
A-2275	22.5°	2	2.250	1.790	1.610	.375	3.750	1.500	.688	1.000	1012T	T-25	SPEB-6352PA

30° Chamfer Mills

Tool Info.

Tool #	Angle	Flutes	D	D-1	D-2	D-3	L	L-1	B	S	Screw	Wrench	Insert
A-5769	30°	2	.625	.485	N/A	N/A	2.500	.750	.156	.500	164T	T-6	SPEB-1511CB
A-5759	30°	2	1.125	.810	.700	.200	3.000	1.000	.312	.750	438T	T-10	SPEB-322P
A-5778	30°	2	1.625	1.200	1.080	.360	3.250	1.250	.438	.750	638T	T-15	SPEB-432PA
A-5763	30°	2	2.250	1.570	1.438	.312	3.750	1.500	.687	1.000	1012T	T-25	SPEB-6352PA

Chipbreaker Insert				
Insert Info.				
Insert #	I.C.	T	R	Grades
SPEB-1511CB	.187	.082	.015	X33 X40

Positive Top Inserts				
Insert Info.				
Insert #	I.C.	T	R	Grades
SPEB-322P	.375	.125	.031	B1M A9M X33 X40
SPEB-432PA	.500	.187	.031	B1M A9M X33 X40
SPEB-6352PA	.750	.220	.031	X33 X40

Speed and Feed Info.			
Material	S.F.M.	.625 Dia. I.P.T.	1.125 - 2.250 Dia. I.P.T.
Mild & Low Carbon Steel Ex. 1018, 1020, 1117, 1141, 12L14	800 - 1200	.002 - .003	.003 - .007
High Carbon & Alloy Steel Ex. 1045, 4140, 4340, 52100, 8620	500 - 800	.002 - .003	.002 - .006
Lower Carbon Tool Steel Ex. P-20, H-13, S-7	400 - 700	.002 - .003	.002 - .006
Tool Steel Ex. A-2, A-6, D-2, M-2	300 - 600	.001 - .003	.002 - .006
Stainless Steel Ex. 304, 316, 420, 15-5PH, 17-4PH	300 - 600	.002 - .003	.002 - .006
Iron Ex. Cast, Ductile, Nodular	600 - 1000	.002 - .003	.004 - .008
Nickel & Titanium Alloy Ex. Inconel, Hastelloy, Ti-6AL-4V	120 - 180	.001 - .002	.001 - .003
Non-Ferrous Metal Ex. Aluminum, Bronze, Brass	1000 - 2500	.002 - .003	.004 - .010

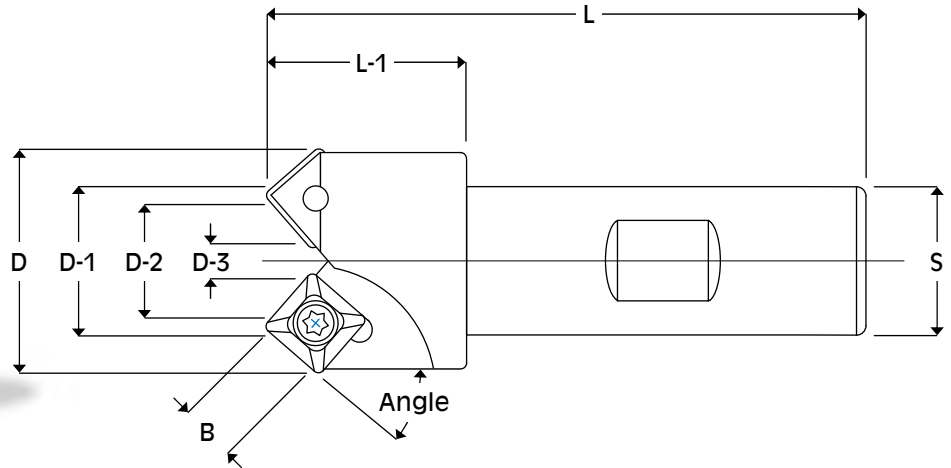

37.5° Chamfer Mills

Tool Info.

Tool #	Angle	Flutes	D	D-1	D-2	D-3	L	L-1	B	S	Screw	Wrench	Insert
A-3750	37.5°	2	1.625	1.090	.980	.320	3.250	1.250	.438	.750	638T	T-15	SPEB-432PA
A-3775	37.5°	2	2.250	1.420	1.300	.250	3.750	1.500	.688	1.000	1012T	T-25	SPEB-6352PA

41° Chamfer Mills

Tool Info.

Tool #	Angle	Flutes	D	D-1	D-2	D-3	L	L-1	B	S	Screw	Wrench	Insert
A-5772	41°	2	.625	.430	N/A	N/A	2.500	.750	.156	.500	164T	T-6	SPEB-1511CB
A-5766	41°	2	1.125	.710	.580	.160	3.000	1.000	.312	.750	438T	T-10	SPEB-322P
A-5779	41°	2	1.625	1.050	.930	.312	3.250	1.250	.438	.750	638T	T-15	SPEB-432PA
A-5767	41°	2	2.250	1.350	1.188	.250	3.750	1.500	.687	1.000	1012T	T-25	SPEB-6352PA

Chipbreaker Insert

Insert Info.

Insert #	I.C.	T	R	Grades
SPEB-1511CB	.187	.082	.015	X33 X40

Positive Top Inserts

Insert Info.

Insert #	I.C.	T	R	Grades
SPEB-322P	.375	.125	.031	B1M A9M X33 X40
SPEB-432PA	.500	.187	.031	B1M A9M X33 X40
SPEB-6352PA	.750	.220	.031	X33 X40

Speed and Feed Info.

Material	S.F.M.	.625 Dia. I.P.T.	1.125 - 2.250 Dia. I.P.T.
Mild & Low Carbon Steel Ex. 1018, 1020, 1117, 1141, 12L14	800 - 1200	.002 - .003	.003 - .007
High Carbon & Alloy Steel Ex. 1045, 4140, 4340, 52100, 8620	500 - 800	.002 - .003	.002 - .006
Lower Carbon Tool Steel Ex. P-20, H-13, S-7	400 - 700	.002 - .003	.002 - .006
Tool Steel Ex. A-2, A-6, D-2, M-2	300 - 600	.001 - .003	.002 - .006
Stainless Steel Ex. 304, 316, 420, 15-5PH, 17-4PH	300 - 600	.002 - .003	.002 - .006
Iron Ex. Cast, Ductile, Nodular	600 - 1000	.002 - .003	.004 - .008
Nickel & Titanium Alloy Ex. Inconel, Hastelloy, Ti-6AL-4V	120 - 180	.001 - .002	.001 - .003
Non-Ferrous Metal Ex. Aluminum, Bronze, Brass	1000 - 2500	.002 - .003	.004 - .010

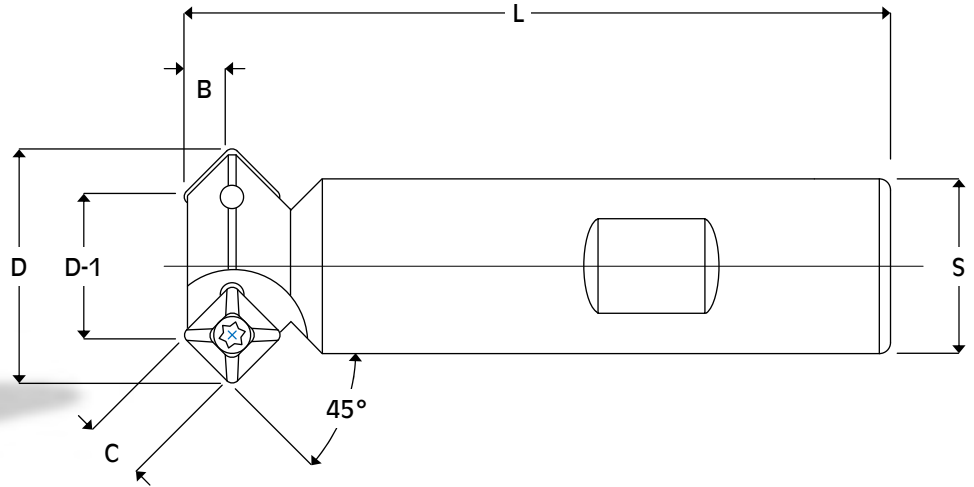

Tool Info.

Tool #	Flutes	D	D-1	L	B	C	S	Insert	Screw	Wrench
A-2399	1	.500	.285	2.875	.110	.156	.500	SPEB-1511CB	164T	T-6
A-2199	1	.625	.320	2.500	.155	.218	.500	SDEB-2151P	300T	T-8
A-2299	2	.625	.410	2.875	.110	.156	.500	SPEB-1511CB	164T	T-6
A-1383	1	1.000	.540	3.000	.220	.312	.750	SPEB-322P	438T	T-10
A-1383-2	2	1.000	.630	3.000	.176	.250	.750	SPEB-2522P	314T	T-8
A-1383XL	2	1.000	.630	6.000	.176	.250	.750			
A-1383MF	4	1.000	.810	3.250	.088	.125	.750	SPEB-1512CB	164T	T-6

Chipbreaker Inserts

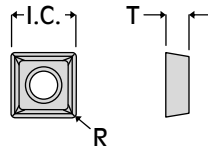

Insert Info.

Insert #	I.C.	T	R	Grades
SPEB-1511CB	.187	.082	.015	X33 X40
SPEB-1512CB	.187	.082	.031	X33

Positive Top Inserts

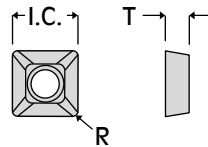

Insert Info.

Insert #	I.C.	T	R	Grades
SDEB-2151P	.250	.125	.015	X33
SPEB-2522P	.312	.125	.031	B1M A9M X33 X40
SPEB-322P	.375	.125	.031	B1M A9M X33 X40

Speed and Feed Info.

Material	S.F.M.	.500 - .625 Dia. I.P.T.	1.000 Dia. I.P.T.
Mild & Low Carbon Steel Ex. 1018, 1020, 1117, 1141, 12L14	800 - 1200	.002 - .003	.003 - .007
High Carbon & Alloy Steel Ex. 1045, 4140, 4340, 52100, 8620	500 - 800	.002 - .003	.002 - .006
Lower Carbon Tool Steel Ex. P-20, H-13, S-7	400 - 700	.002 - .003	.002 - .006
Tool Steel Ex. A-2, A-6, D-2, M-2	300 - 600	.001 - .003	.002 - .006
Stainless Steel Ex. 304, 316, 420, 15-5PH, 17-4PH	300 - 600	.002 - .003	.002 - .006
Iron Ex. Cast, Ductile, Nodular	600 - 1000	.002 - .003	.004 - .008
Nickel & Titanium Alloy Ex. Inconel, Hastelloy, Ti-6AL-4V	120 - 180	.001 - .002	.001 - .003
Non-Ferrous Metal Ex. Aluminum, Bronze, Brass	1000 - 2500	.002 - .003	.004 - .010

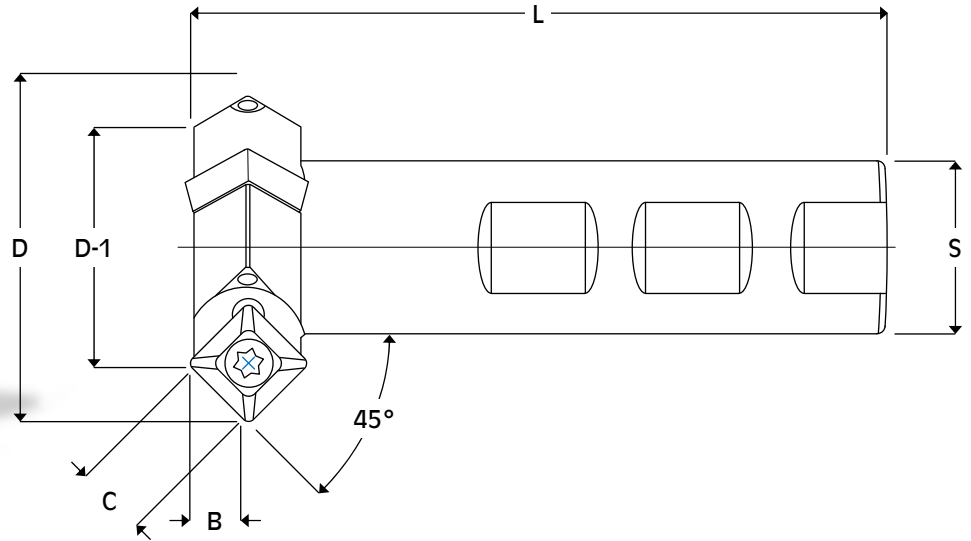

Tool Info.

Tool #	Flutes	D	D-1	L	B	C	S	Insert	Screw	Wrench
A-1384	2	1.250	.790	4.000	.220	.312	.750	SPEB-322P	438T	T-10
A-1384XL	2	1.250	.790	6.000	.220	.312	.750			
A-1384MF	4	1.250	.970	3.500	.132	.188	.750	SPEB-222P	314T	T-8
A-1385	3	1.500	1.045	4.000	.220	.312	.750	SPEB-322P	438T	T-10
A-1385XL	3	1.500	1.045	6.000	.220	.312	.750			
A-1385MF	4	1.500	1.220	3.500	.132	.188	.750	SPEB-222P	314T	T-8
A-1386	3	2.000	1.370	4.000	.309	.437	1.000	SPEB-432PA	638T	T-15
A-1386XL	3	2.000	1.370	6.000	.309	.437	1.000			
A-1386MF	5	2.000	1.635	3.750	.176	.250	1.000	SPEB-2522P	314T	T-8
A-1387	3	2.500	1.510	4.500	.486	.687	1.250	SPEB-6352PA	1012T	T-25
A-1388	3	3.500	2.160	5.000	.663	.937	1.500	SPEB-842PA	1412T	T-532

Positive Top Inserts

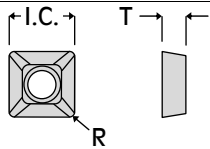

Insert Info.

Insert #	I.C.	T	R	Grades
SPEB-222P	.250	.125	.031	A9M B1M X33
SPEB-2522P	.312	.125	.031	A9M B1M X33 X40
SPEB-322P	.375	.125	.031	A9M B1M X33 X40
SPEB-432PA	.500	.187	.031	A9M B1M X33 X40
SPEB-6352PA	.750	.220	.031	X33 X40
SPEB-842PA	1.000	.250	.031	X33

Speed and Feed Info.

Material	S.F.M.	I.P.T.
Mild & Low Carbon Steel Ex. 1018, 1020, 1117, 1141, 12L14	800 - 1200	.003 - .007
High Carbon & Alloy Steel Ex. 1045, 4140, 4340, 52100, 8620	500 - 800	.002 - .006
Lower Carbon Tool Steel Ex. P-20, H-13, S-7	400 - 700	.002 - .006
Tool Steel Ex. A-2, A-6, D-2, M-2	300 - 600	.002 - .006
Stainless Steel Ex. 304, 316, 420, 15-5PH, 17-4PH	300 - 600	.002 - .006
Iron Ex. Cast, Ductile, Nodular	600 - 1000	.004 - .008
Nickel & Titanium Alloy Ex. Inconel, Hastelloy, Ti-6AL-4V	120 - 180	.001 - .003
Non-Ferrous Metal Ex. Aluminum, Bronze, Brass	1000 - 2500	.004 - .010

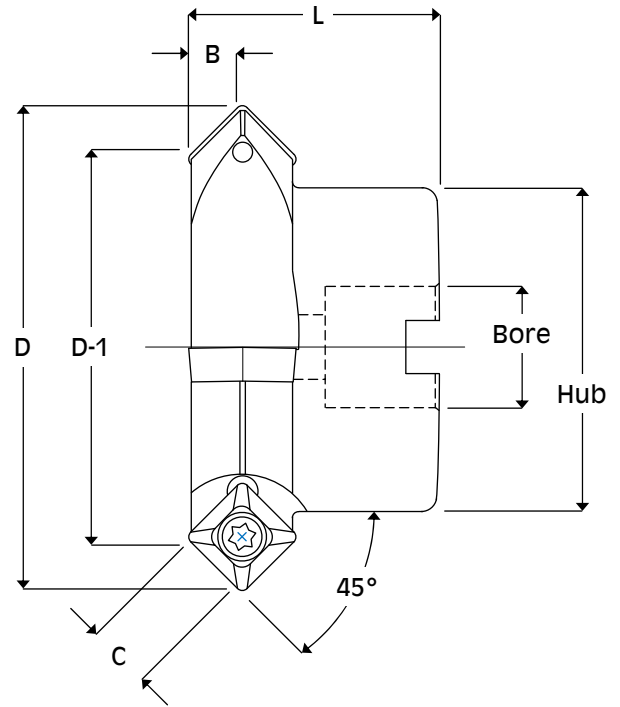

Shell Mills		Tool Info.										
Tool #	Flutes	D	D-1	L	B	C	Bore	Key	Hub	Screw	Wrench	Insert
A-2000S	4	2.000	1.550	1.250	.220	.312	.500	.250	1.375	538T	T-10	SPEB-332P
A-3000S	4	3.000	2.375	1.500	.309	.437	.750	.312	2.000	638T	T-15	SPEB-432PA
A-4000S	4	4.000	3.030	1.625	.486	.687	1.000	.375	2.375	1012T	T-25	SPEB-6352PA

Positive Top Inserts		T		R	
<i>Insert Info.</i>					
Insert #	I.C.	T	R	Grades	
SPEB-332P	.375	.187	.031	A9M B1M X33 X40	
SPEB-432PA	.500	.187	.031	A9M B1M X33 X40	
SPEB-6352PA	.750	.220	.031	X33 X40	

Speed and Feed Info.		
Material	S.F.M.	I.P.T.
Mild & Low Carbon Steel Ex. 1018, 1020, 1117, 1141, 12L14	800 - 1200	.003 - .007
High Carbon & Alloy Steel Ex. 1045, 4140, 4340, 52100, 8620	500 - 800	.002 - .006
Lower Carbon Tool Steel Ex. P-20, H-13, S-7	400 - 700	.002 - .006
Tool Steel Ex. A-2, A-6, D-2, M-2	300 - 600	.002 - .006
Stainless Steel Ex. 304, 316, 420, 15-5PH, 17-4PH	300 - 600	.002 - .006
Iron Ex. Cast, Ductile, Nodular	600 - 1000	.004 - .008
Nickel & Titanium Alloy Ex. Inconel, Hastelloy, Ti-6AL-4V	120 - 180	.001 - .003
Non-Ferrous Metal Ex. Aluminum, Bronze, Brass	1000 - 2500	.004 - .010

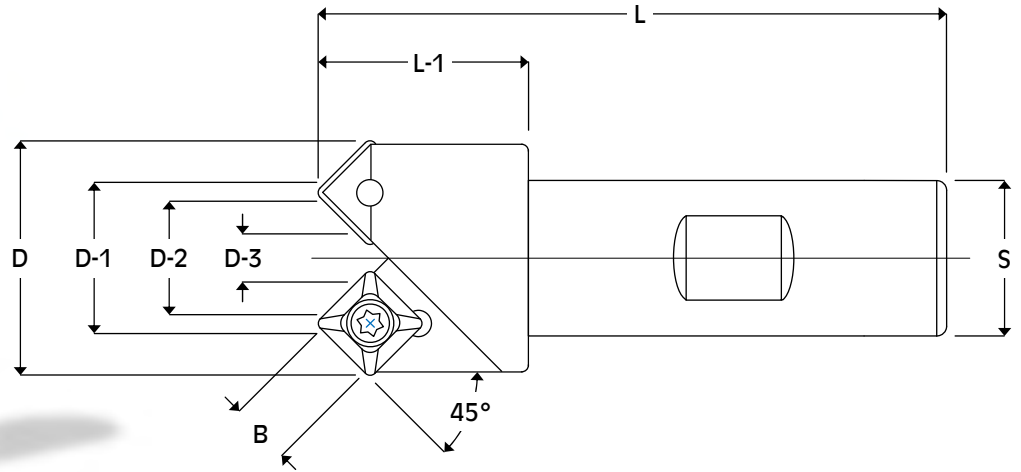

Tool Info.

Tool #	Flutes	D	D-1	D-2	D-3	L	L-1	B	S	Screw	Wrench	Insert
OD-0545	2	1.125	.625	.550	.160	3.000	1.000	.312	.750	438T	T-10	SPEB-322P
OD-1245	2	2.187	1.400	1.250	.550	3.750	1.500	.563	1.000	838T	T-20	SPEB-532PA

Speed and Feed Info.

Material	S.F.M.	I.P.T.
Mild & Low Carbon Steel Ex. 1018, 1020, 1117, 1141, 12L14	800 - 1200	.003 - .007
High Carbon & Alloy Steel Ex. 1045, 4140, 4340, 52100, 8620	500 - 800	.002 - .006
Lower Carbon Tool Steel Ex. P-20, H-13, S-7	400 - 700	.002 - .006
Tool Steel Ex. A-2, A-6, D-2, M-2	300 - 600	.002 - .006
Stainless Steel Ex. 304, 316, 420, 15-5PH, 17-4PH	300 - 600	.002 - .006
Iron Ex. Cast, Ductile, Nodular	600 - 1000	.004 - .008
Nickel & Titanium Alloy Ex. Inconel, Hastelloy, Ti-6AL-4V	120 - 180	.001 - .003
Non-Ferrous Metal Ex. Aluminum, Bronze, Brass	1000 - 2500	.004 - .010

Positive Top Inserts

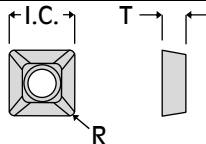

Insert Info.

Insert #	I.C.	T	R	Grades
SPEB-322P	.375	.125	.031	B1M A9M X33 X40
SPEB-532PA	.625	.187	.031	X33

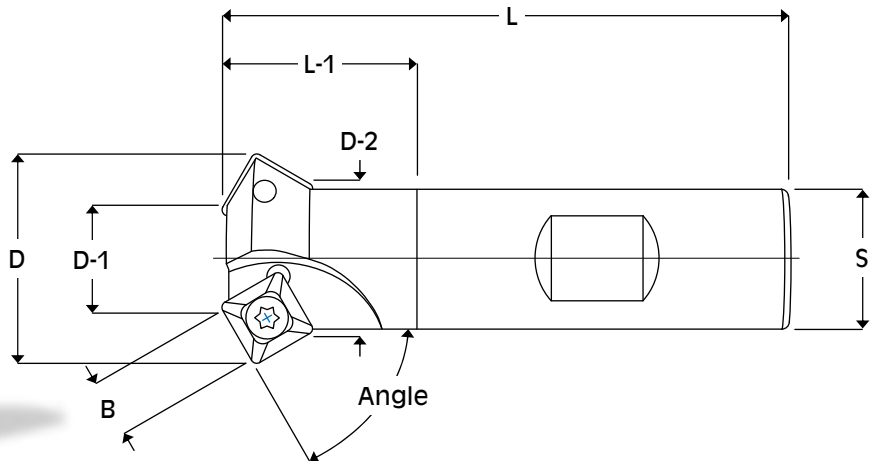

60° Chamfer Mills

Tool Info.

Tool #	Angle	Flutes	D	D-1	D-2	L	L-1	B	S	Screw	Wrench	Insert
A-5771	60°	2	.625	.350	.480	2.500	.750	.156	.500	164T	T-6	SPEB-1511CB
A-5761	60°	2	1.125	.560	.820	3.000	1.000	.312	.750	438T	T-10	SPEB-322P
A-5780	60°	2	1.625	.860	1.190	3.250	1.250	.438	.750	638T	T-15	SPEB-432PA
A-5765	60°	2	2.250	1.040	1.570	3.750	1.500	.687	1.000	1012T	T-25	SPEB-6352PA

67.5° Chamfer Mills

Tool Info.

Tool #	Angle	Flutes	D	D-1	D-2	L	L-1	B	S	Screw	Wrench	Insert
A-6750	67.5°	2	1.625	.790	1.300	3.250	1.250	.438	.750	638T	T-15	SPEB-432PA
A-6775	67.5°	2	2.250	.960	1.750	3.750	1.500	.687	1.000	1012T	T-25	SPEB-6352PA

Chipbreaker Insert

Insert Info.

Insert #	I.C.	T	R	Grades
SPEB-1511CB	.187	.082	.015	X33 X40

Positive Top Inserts

Insert Info.

Insert #	I.C.	T	R	Grades
SPEB-322P	.375	.125	.031	B1M A9M X33 X40
SPEB-432PA	.500	.187	.031	B1M A9M X33 X40
SPEB-6352PA	.750	.220	.031	X33 X40

Speed and Feed Info.

Material	S.F.M.	.625 Dia. I.P.T.	1.125 - 2.250 Dia. I.P.T.
Mild & Low Carbon Steel Ex. 1018, 1020, 1117, 1141, 12L14	800 - 1200	.002 - .003	.003 - .007
High Carbon & Alloy Steel Ex. 1045, 4140, 4340, 52100, 8620	500 - 800	.002 - .003	.002 - .006
Lower Carbon Tool Steel Ex. P-20, H-13, S-7	400 - 700	.002 - .003	.002 - .006
Tool Steel Ex. A-2, A-6, D-2, M-2	300 - 600	.001 - .003	.002 - .006
Stainless Steel Ex. 304, 316, 420, 15-5PH, 17-4PH	300 - 600	.002 - .003	.002 - .006
Iron Ex. Cast, Ductile, Nodular	600 - 1000	.002 - .003	.004 - .008
Nickel & Titanium Alloy Ex. Inconel, Hastelloy, Ti-6AL-4V	120 - 180	.001 - .002	.001 - .003
Non-Ferrous Metal Ex. Aluminum, Bronze, Brass	1000 - 2500	.002 - .003	.004 - .010

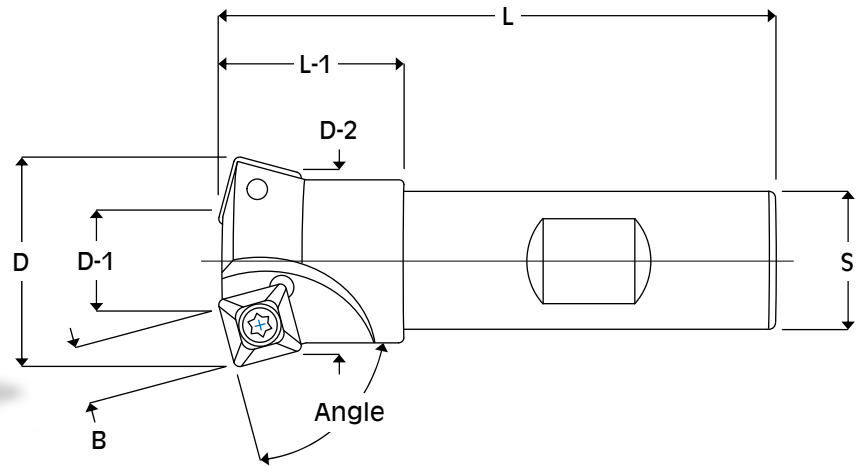

70° Chamfer Mills

Tool Info.

Tool #	Angle	Flutes	D	D-1	D-2	L	L-1	B	S	Screw	Wrench	Insert
A-5782	70°	2	.625	.320	.530	2.500	.750	.156	.500	164T	T-6	SPEB-1511CB
A-5783	70°	2	1.125	.510	.930	3.000	1.000	.312	.750	438T	T-10	SPEB-322P
A-5784	70°	2	1.625	.780	1.330	3.250	1.250	.438	.750	638T	T-15	SPEB-432PA
A-5785	70°	2	2.250	.930	1.790	3.750	1.500	.687	1.000	1012T	T-25	SPEB-6352PA

75° Chamfer Mills

Tool Info.

Tool #	Angle	Flutes	D	D-1	D-2	L	L-1	B	S	Screw	Wrench	Insert
A-5770	75°	2	.625	.320	.550	2.500	.750	.156	.500	164T	T-6	SPEB-1511CB
A-5760	75°	2	1.125	.480	.970	3.000	1.000	.312	.750	438T	T-10	SPEB-322P
A-5781	75°	2	1.625	.750	1.420	3.250	1.250	.438	.750	638T	T-15	SPEB-432PA
A-5764	75°	2	2.250	.880	1.900	3.750	1.500	.687	1.000	1012T	T-25	SPEB-6352PA

Chipbreaker Insert

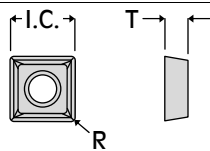

Insert Info.

Insert #	I.C.	T	R	Grades
SPEB-1511CB	.187	.082	.015	X33 X40

Positive Top Inserts

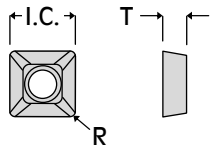

Insert Info.

Insert #	I.C.	T	R	Grades
SPEB-322P	.375	.125	.031	B1M A9M X33 X40
SPEB-432PA	.500	.187	.031	B1M A9M X33 X40
SPEB-6352PA	.750	.220	.031	X33 X40

Speed and Feed Info.

Material	S.F.M.	.625 Dia. I.P.T.	1.125 - 2.250 Dia. I.P.T.
Mild & Low Carbon Steel Ex. 1018, 1020, 1117, 1141, 12L14	800 - 1200	.002 - .003	.003 - .007
High Carbon & Alloy Steel Ex. 1045, 4140, 4340, 52100, 8620	500 - 800	.002 - .003	.002 - .006
Lower Carbon Tool Steel Ex. P-20, H-13, S-7	400 - 700	.002 - .003	.002 - .006
Tool Steel Ex. A-2, A-6, D-2, M-2	300 - 600	.001 - .003	.002 - .006
Stainless Steel Ex. 304, 316, 420, 15-5PH, 17-4PH	300 - 600	.002 - .003	.002 - .006
Iron Ex. Cast, Ductile, Nodular	600 - 1000	.002 - .003	.004 - .008
Nickel & Titanium Alloy Ex. Inconel, Hastelloy, Ti-6AL-4V	120 - 180	.001 - .002	.001 - .003
Non-Ferrous Metal Ex. Aluminum, Bronze, Brass	1000 - 2500	.002 - .003	.004 - .010

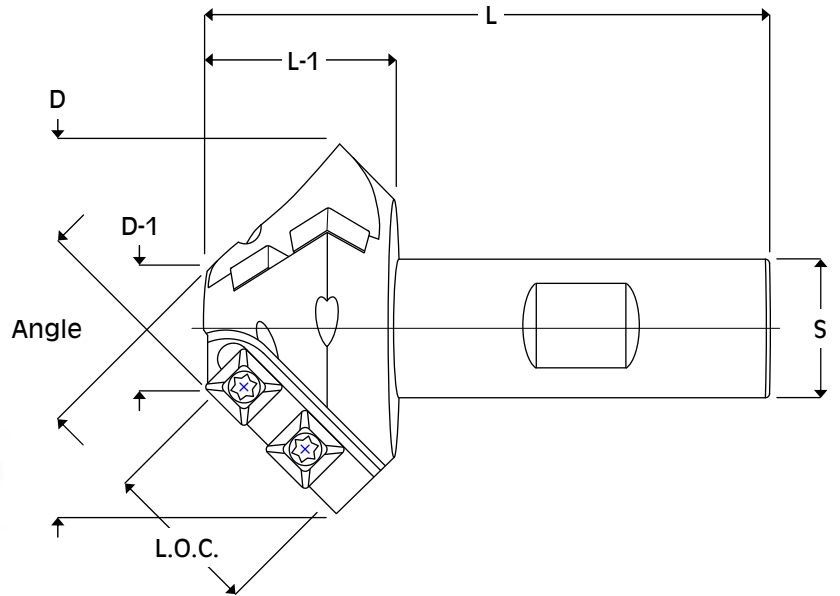

Shank Tools				Tool Info.								
Tool #	Angle	Flutes	Inserts	D	D-1	L	L-1	L.O.C.	S	Screw	Wrench	Insert
CC-40	40°	4-2 Effective	8	2.030	1.386	3.125	1.125	.900	.750	314T	T-8	SPEB-2522P
CC-60	60°	4-2 Effective	8	2.030	1.090	3.062	1.062	.900	.750			
CC-82	82°	3-1 Effective	6	2.030	.775	3.000	1.000	.900	.750			
CC-90	90°	3-1 Effective	6	2.030	.660	3.000	1.000	.900	.750			
CC-120	120°	2-1 Effective	4	2.030	.390	3.000	1.000	.900	.750			

Positive Top Insert				
Insert Info.				
Insert #	I.C.	T	R	Grades
SPEB-2522P	.312	.125	.031	B1M A9M X33 X40

Speed and Feed Info.		
Material	S.F.M.	I.P.T.
Mild & Low Carbon Steel Ex. 1018, 1020, 1117, 1141, 12L14	800 - 1200	.003 - .007
High Carbon & Alloy Steel Ex. 1045, 4140, 4340, 52100, 8620	500 - 800	.002 - .006
Lower Carbon Tool Steel Ex. P-20, H-13, S-7	400 - 700	.002 - .006
Tool Steel Ex. A-2, A-6, D-2, M-2	300 - 600	.002 - .006
Stainless Steel Ex. 304, 316, 420, 15-5PH, 17-4PH	300 - 600	.002 - .006
Iron Ex. Cast, Ductile, Nodular	600 - 1000	.004 - .008
Nickel & Titanium Alloy Ex. Inconel, Hastelloy, Ti-6AL-4V	120 - 180	.001 - .003
Non-Ferrous Metal Ex. Aluminum, Bronze, Brass	1000 - 2500	.004 - .010

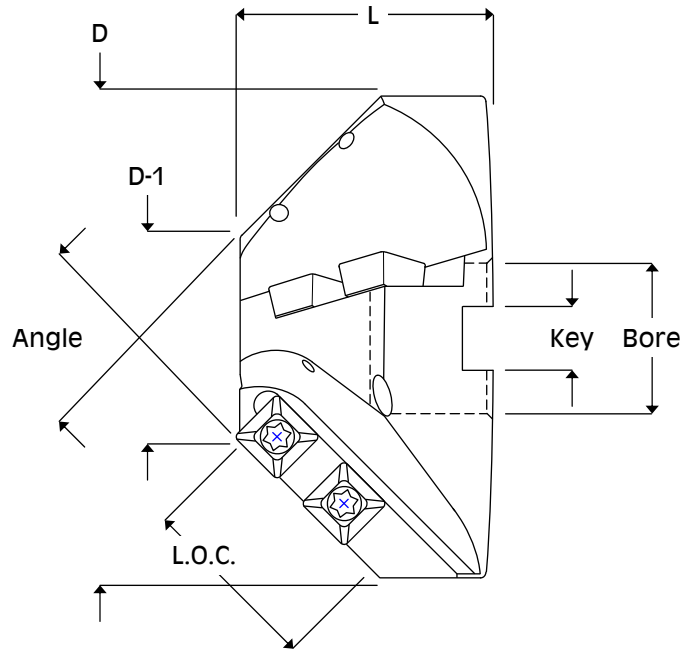

Shell Mills		Tool Info.										
Tool #	Angle	Flutes	Inserts	D	D-1	L	L.O.C.	Bore	Key	Screw	Wrench	Insert
CCS-601	60°	4-2 Effective	8	3.000	1.840	1.625	1.130	1.000	.375	538T	T-10	SPEB-332P
CCS-602	60°	4-2 Effective	14	4.000	1.970	2.250	2.000	1.250	.500			
CCS-821	82°	4-2 Effective	8	3.250	1.718	1.625	1.130	1.000	.375			
CCS-822	82°	4-2 Effective	14	4.500	1.750	2.000	2.000	1.250	.500			
CCS-901	90°	4-2 Effective	8	2.985	1.250	1.500	1.130	.750	.312			
CCS-902	90°	4-2 Effective	14	4.720	1.750	2.000	2.000	1.250	.500			
CCS-1201	120°	4-2 Effective	8	3.625	1.580	1.625	1.130	1.000	.375			
CCS-1202	120°	4-2 Effective	14	5.375	1.820	2.000	2.000	1.250	.500			

Positive Top Insert				
	<i>Insert Info.</i>			
Insert #	I.C.	T	R	Grades
SPEB-332P	.375	.187	.031	B1M A9M X33 X40

Speed and Feed Info.		
Material	S.F.M.	I.P.T.
Mild & Low Carbon Steel Ex. 1018, 1020, 1117, 1141, 12L14	800 - 1200	.003 - .007
High Carbon & Alloy Steel Ex. 1045, 4140, 4340, 52100, 8620	500 - 800	.002 - .006
Lower Carbon Tool Steel Ex. P-20, H-13, S-7	400 - 700	.002 - .006
Tool Steel Ex. A-2, A-6, D-2, M-2	300 - 600	.002 - .006
Stainless Steel Ex. 304, 316, 420, 15-5PH, 17-4PH	300 - 600	.002 - .006
Iron Ex. Cast, Ductile, Nodular	600 - 1000	.004 - .008
Nickel & Titanium Alloy Ex. Inconel, Hastelloy, Ti-6AL-4V	120 - 180	.001 - .003
Non-Ferrous Metal Ex. Aluminum, Bronze, Brass	1000 - 2500	.004 - .010

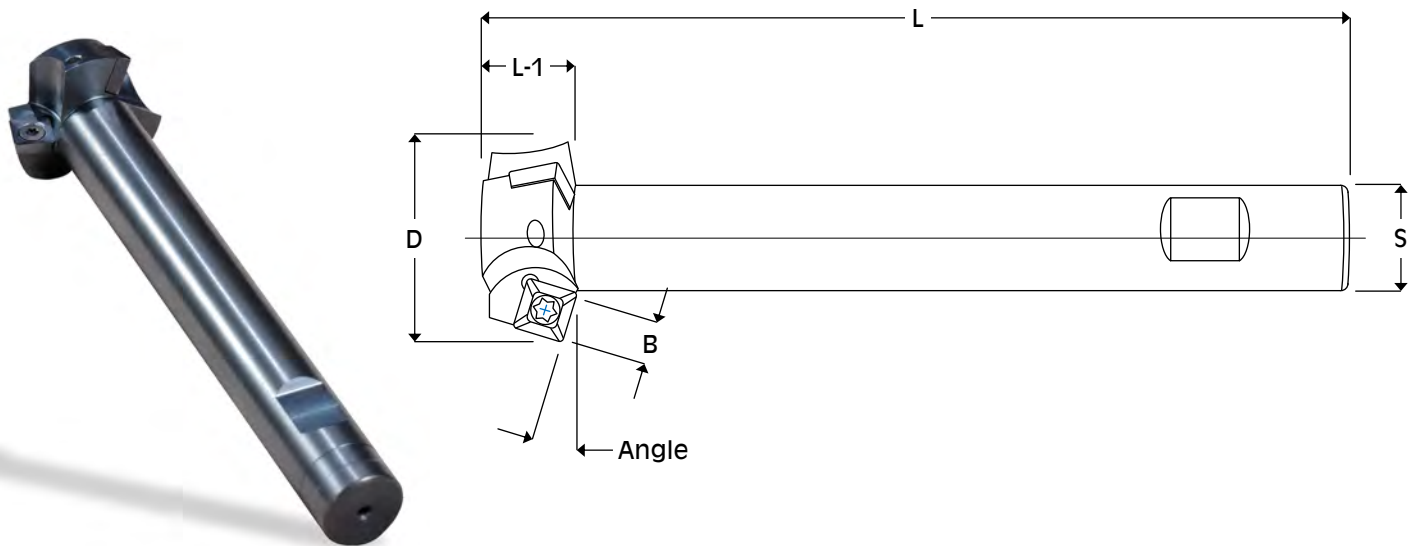

<i>Shank Tools</i>					<i>Tool Info.</i>					
Tool #	Angle	Flutes	D	L	L-1	B	S	Insert	Screw	Wrench
CMR-1515	15°	3	1.500	6.000	.625	.312	.750	SPEB-322P	438T	T-10
CMR-2515	15°	3	2.500	6.000	1.250	.687	1.000	SPEB-6352PA	1012T	T-25
CMR-1530	30°	3	1.500	6.000	.625	.312	.750	SPEB-322P	438T	T-10
CMR-2530	30°	3	2.500	6.000	1.250	.687	1.000	SPEB-6352PA	1012T	T-25
CMR-1560	60°	3	1.500	6.000	.795	.312	.750	SPEB-322P	438T	T-10
CMR-2560	60°	3	2.500	6.000	1.650	.687	1.000	SPEB-6352PA	1012T	T-25

Positive Top Inserts				
<i>Insert Info.</i>				
Insert #	I.C.	T	R	Grades
SPEB-322P	.375	.125	.031	B1M A9M X33 X40
SPEB-6352PA	.750	.220	.031	X33 X40

<i>Speed and Feed Info.</i>		
Material	S.F.M.	I.P.T.
Mild & Low Carbon Steel Ex. 1018, 1020, 1117, 1141, 12L14	800 - 1200	.003 - .007
High Carbon & Alloy Steel Ex. 1045, 4140, 4340, 52100, 8620	500 - 800	.002 - .006
Lower Carbon Tool Steel Ex. P-20, H-13, S-7	400 - 700	.002 - .006
Tool Steel Ex. A-2, A-6, D-2, M-2	300 - 600	.002 - .006
Stainless Steel Ex. 304, 316, 420, 15-5PH, 17-4PH	300 - 600	.002 - .006
Iron Ex. Cast, Ductile, Nodular	600 - 1000	.004 - .008
Nickel & Titanium Alloy Ex. Inconel, Hastelloy, Ti-6AL-4V	120 - 180	.001 - .003
Non-Ferrous Metal Ex. Aluminum, Bronze, Brass	1000 - 2500	.004 - .010

Multi-Angle Chamfer Tools

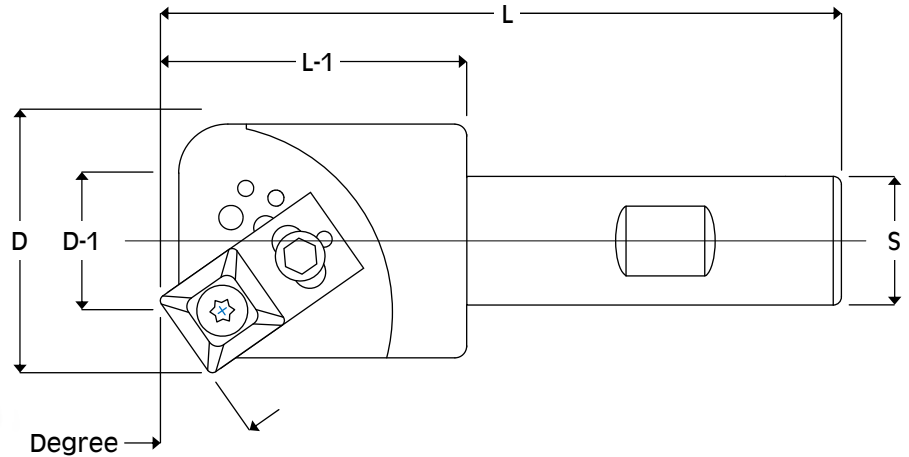

Achieve Any Angle With A Comparator

<i>Shank Tools</i>				<i>Tool Info.</i>			
Tool #	Flutes	L	L-1	S	Cartridge	Cartridge Screw	Insert
AC-750	1	3.000	1.000	.750	AC2-Cart	#25638	SDEB-2151P
AC-1250	1	3.500	1.500	.750	AC-Cart	#83212	SPEB-422PA
AC-1500	1	3.500	1.500	.750			

<i>Standard Preset Angle Dimensions</i>				<i>Tool Info.</i>								
Tool #	0°		15°		30°		45°		60°		75°	
	D	D-1	D	D-1	D	D-1	D	D-1	D	D-1	D	D-1
AC-750	.750	-	.770	.350	.810	.420	.820	.520	.810	.600	.790	.680
AC-1250	1.250	-	1.310	.450	1.390	.590	1.430	.790	1.390	.970	1.350	1.120
AC-1500	1.500	-	1.560	.700	1.640	.840	1.680	1.040	1.640	1.220	1.600	1.370

<i>Positive Top Inserts</i>						
<i>Insert Info.</i>						
Insert #	I.C.	T	R	Screw	Wrench	Grade
SDEB-2151P	.250	.093	.015	300T	T-8	X33
SPEB-422PA	.500	.125	.031	614T	T-15	X33

<i>Speed and Feed Info.</i>		
Material	S.F.M.	I.P.T.
Mild & Low Carbon Steel Ex. 1018, 1020, 1117, 1141, 12L14	800 - 1200	.003 - .007
High Carbon & Alloy Steel Ex. 1045, 4140, 4340, 52100, 8620	500 - 800	.002 - .006
Lower Carbon Tool Steel Ex. P-20, H-13, S-7	400 - 700	.002 - .006
Tool Steel Ex. A-2, A-6, D-2, M-2	300 - 600	.002 - .006
Stainless Steel Ex. 304, 316, 420, 15-5PH, 17-4PH	300 - 600	.002 - .006
Iron Ex. Cast, Ductile, Nodular	600 - 1000	.004 - .008
Nickel & Titanium Alloy Ex. Inconel, Hastelloy, Ti-6AL-4V	120 - 180	.001 - .003
Non-Ferrous Metal Ex. Aluminum, Bronze, Brass	1000 - 2500	.004 - .010

Multi-Angle Chamfer Tool

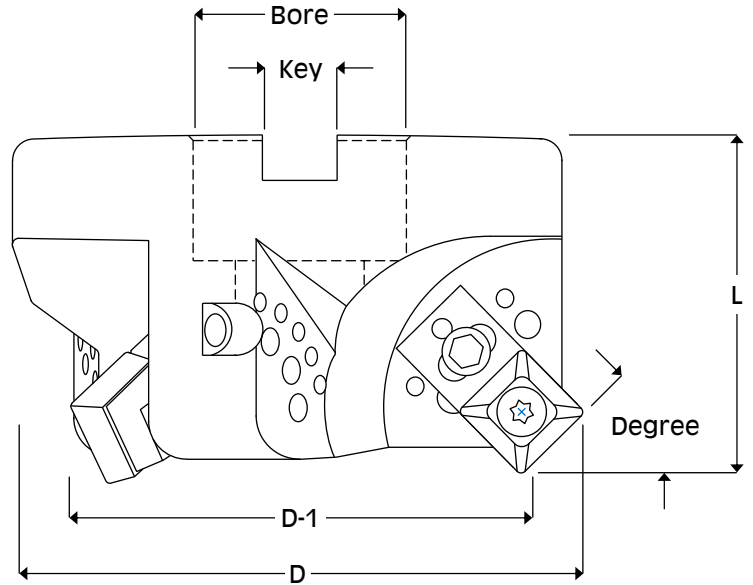

Achieve Any Angle With A Comparator

<i>Shell Mill</i>		<i>Tool Info.</i>					
Tool #	Flutes	L	Bore	Key	Cartridge	Cartridge Screw	Insert
AC-3000	3	1.625	1.000	.375	AC3-Cart	#83234	SPEB-432PA

<i>Standard Preset Angle Dimensions</i>		<i>Tool Info.</i>										
Tool #	0°		15°		30°		45°		60°		75°	
	D	D-1	D	D-1	D	D-1	D	D-1	D	D-1	D	D-1
AC-3000	3.000	-	3.080	2.250	3.180	2.440	3.220	2.620	3.210	2.780	3.160	2.940

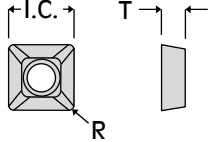
<i>Positive Top Insert</i>						
						
<i>Insert Info.</i>						
Insert #	I.C.	T	R	Screw	Wrench	Grades
SPEB-432PA	.500	.187	.031	638T	T-15	B1M A9M X33 X40

<i>Speed and Feed Info.</i>		
Material	S.F.M.	I.P.T.
Mild & Low Carbon Steel Ex. 1018, 1020, 1117, 1141, 12L14	800 - 1200	.002 - .005
High Carbon & Alloy Steel Ex. 1045, 4140, 4340, 52100, 8620	500 - 800	.002 - .004
Lower Carbon Tool Steel Ex. P-20, H-13, S-7	400 - 700	.002 - .004
Tool Steel Ex. A-2, A-6, D-2, M-2	300 - 600	.002 - .004
Stainless Steel Ex. 304, 316, 420, 15-5PH, 17-4PH	300 - 600	.002 - .004
Iron Ex. Cast, Ductile, Nodular	600 - 1000	.003 - .007
Nickel & Titanium Alloy Ex. Inconel, Hastelloy, Ti-6AL-4V	120 - 180	.001 - .002
Non-Ferrous Metal Ex. Aluminum, Bronze, Brass	1000 - 2500	.003 - .007

Multi-Angle Chamfer Tool

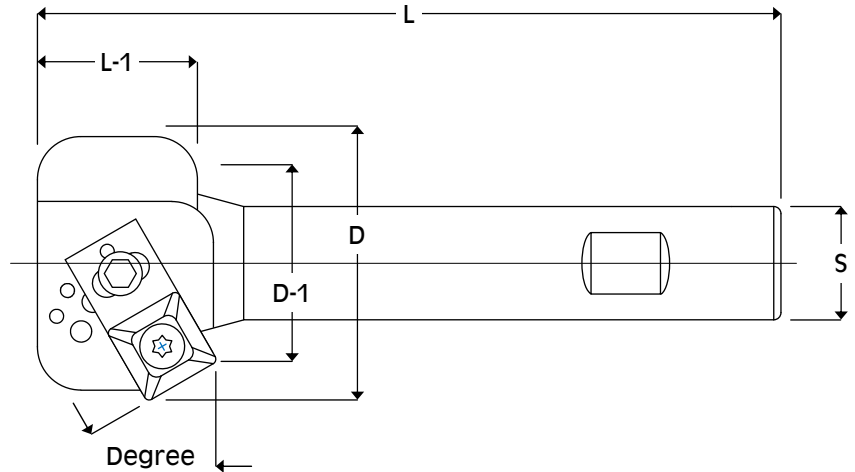

Achieve Any Angle With A Comparator

<i>Shank Tool</i>		<i>Tool Info.</i>					
Tool #	Flutes	L	L-1	S	Cartridge	Cartridge Screw	Insert
ACR-1500	1	4.500	1.000	.750	AC-Cart	#83212	SPEB-422PA

<i>Standard Preset Angle Dimensions</i>		<i>Tool Info.</i>										
Tool #	0°		15°		30°		45°		60°		75°	
	D	D-1	D	D-1	D	D-1	D	D-1	D	D-1	D	D-1
ACR-1500	1.500	-	1.560	.700	1.640	.840	1.680	1.040	1.640	1.220	1.600	1.370

<i>Positive Top Insert</i>						
<i>Insert Info.</i>						
Insert #	I.C.	T	R	Screw	Wrench	Grade
SPEB-422PA	.500	.125	.031	614T	T-15	X33

<i>Speed and Feed Info.</i>		
Material	S.F.M.	I.P.T.
Mild & Low Carbon Steel Ex. 1018, 1020, 1117, 1141, 12L14	800 - 1200	.002 - .005
High Carbon & Alloy Steel Ex. 1045, 4140, 4340, 52100, 8620	500 - 800	.002 - .004
Lower Carbon Tool Steel Ex. P-20, H-13, S-7	400 - 700	.002 - .004
Tool Steel Ex. A-2, A-6, D-2, M-2	300 - 600	.002 - .004
Stainless Steel Ex. 304, 316, 420, 15-5PH, 17-4PH	300 - 600	.002 - .004
Iron Ex. Cast, Ductile, Nodular	600 - 1000	.003 - .007
Nickel & Titanium Alloy Ex. Inconel, Hastelloy, Ti-6AL-4V	120 - 180	.001 - .002
Non-Ferrous Metal Ex. Aluminum, Bronze, Brass	1000 - 2500	.003 - .007

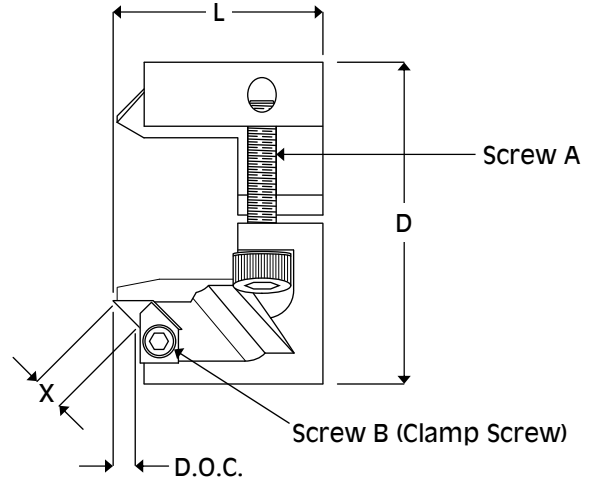

Tool Info.

Tool #	Drill Body Dia.	D.O.C	X	L	D	Insert
DCR-30-40	.300 - .400	.180	.250	1.000	1.220	DDG-45
DCR-40-50	.401 - .500			1.000	1.220	
DCR-50-62	.501 - .625			1.140	1.470	
DCR-62-75	.626 - .750			1.140	1.470	
DCR-75-87	.751 - .875			1.280	1.730	
DCR-87-100	.876 - 1.000			1.280	1.730	
DCR-100-112	1.001 - 1.125			1.280	1.970	
DCR-112-125	1.126 - 1.250			1.280	1.970	
DCR-125-138	1.251 - 1.375			1.440	2.130	
DCR-138-150	1.376 - 1.500			1.440	2.250	

Tool #	Screw A	Wrench	Screw B	Wrench	Clamp
DCR-30-40	#103275	5/32"	#44025	3/32"	KCL-1
DCR-40-50					
DCR-50-62					
DCR-62-75					
DCR-75-87	#142810	3/16"			
DCR-87-100					
DCR-100-112					
DCR-112-125					
DCR-125-138					
DCR-138-150					

Insert Info.

Insert #	A	B	T	Grade
DDG-45	.190	.187	.093	X33

Allen wrenches are not supplied with Chamfer Rings.

Dovetail Cutters



Available in 15°, 30° and 45°

Applications

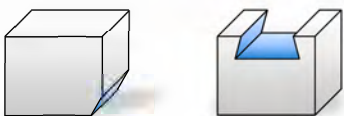

45° Dovetail Cutters

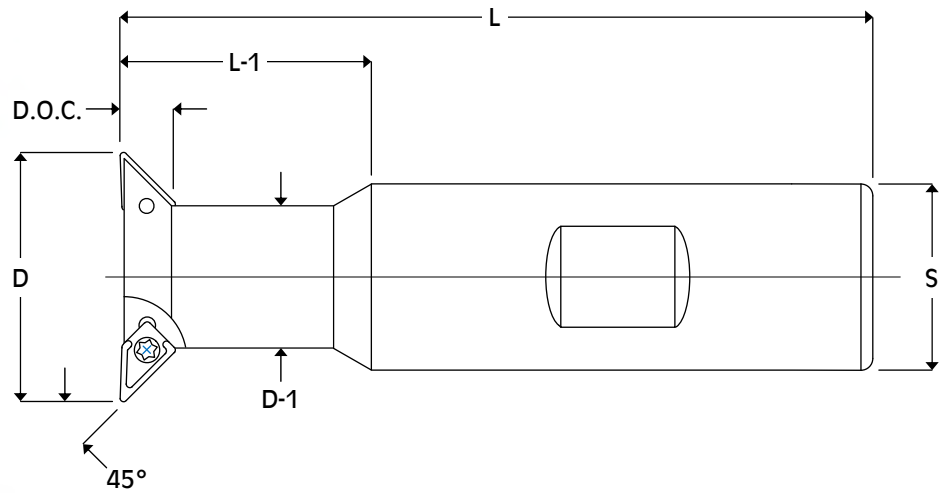

Tool Info.

Tool #	D	D-1	Flutes	L	L-1	D.O.C.	S	Insert
DT-5050	.500	.312	1	2.500	.750	.110	.500	DTI-1511P
DT-6250	.625	.312	1	2.500	.750	.170	.500	
DT-7550	.750	.375	1	2.500	.750	.200	.500	
DT-1175	1.000	.562	2	3.000	1.000	.200	.750	
DT-1210	1.250	.812	3	3.500	1.250	.200	1.000	

Insert Info

DTI-1511P	
Grade	X33
A	.328
B	.187
T	.082
R	.015
Screw	164T
Wrench	T-6

Speed and Feed Info.

Material	S.F.M.	I.P.T.
Mild & Low Carbon Steel Ex. 1018, 1020, 1117, 1141, 12L14	800 - 1200	.001 - .002
High Carbon & Alloy Steel Ex. 1045, 4140, 4340, 52100, 8620	500 - 800	.001 - .002
Lower Carbon Tool Steel Ex. P-20, H-13, S-7	400 - 700	.001 - .002
Tool Steel Ex. A-2, A-6, D-2, M-2	300 - 600	.001 - .002
Stainless Steel Ex. 304, 316, 420, 15-5PH, 17-4PH	300 - 600	.001 - .002
Iron Ex. Cast, Ductile, Nodular	600 - 1000	.001 - .002
Nickel & Titanium Alloy Ex. Inconel, Hastelloy, Ti-6AL-4V	120 - 180	.001 - .002
Non-Ferrous Metal Ex. Aluminum, Bronze, Brass	1000 - 2500	.001 - .003

30° Dovetail Cutters

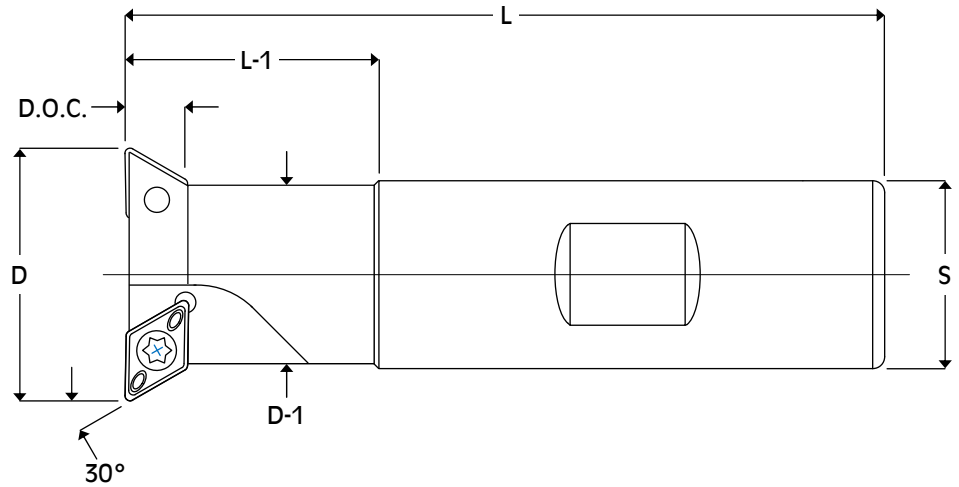

Tool Info.

Tool #	D	D-1	Flutes	L	L-1	D.O.C.	S	Inserts
DT-1075	1.000	.700	2	3.000	1.000	.220	.750	DDEB-2151P
DT-1575	1.500	1.062	2	3.250	1.250	.345	.750	DPEB-3252P

Insert Info	
DDEB-2151P	
Grades	X33 X40
I.C.	.250
T	.095
R	.015
Screw	314T
Wrench	T-8

Insert Info	
DPEB-3252P	
Grade	X33
I.C.	.375
T	.160
R	.031
Screw	538T
Wrench	T-10

Speed and Feed Info.

Material	S.F.M.	I.P.T.
Mild & Low Carbon Steel Ex. 1018, 1020, 1117, 1141, 12L14	800 - 1200	.002 - .005
High Carbon & Alloy Steel Ex. 1045, 4140, 4340, 52100, 8620	500 - 800	.002 - .005
Lower Carbon Tool Steel Ex. P-20, H-13, S-7	400 - 700	.002 - .005
Tool Steel Ex. A-2, A-6, D-2, M-2	300 - 600	.002 - .005
Stainless Steel Ex. 304, 316, 420, 15-5PH, 17-4PH	300 - 600	.002 - .005
Iron Ex. Cast, Ductile, Nodular	600 - 1000	.002 - .006
Nickel & Titanium Alloy Ex. Inconel, Hastelloy, Ti-6AL-4V	120 - 180	.001 - .002
Non-Ferrous Metal Ex. Aluminum, Bronze, Brass	1000 - 2500	.002 - .006

15° Dovetail Cutters

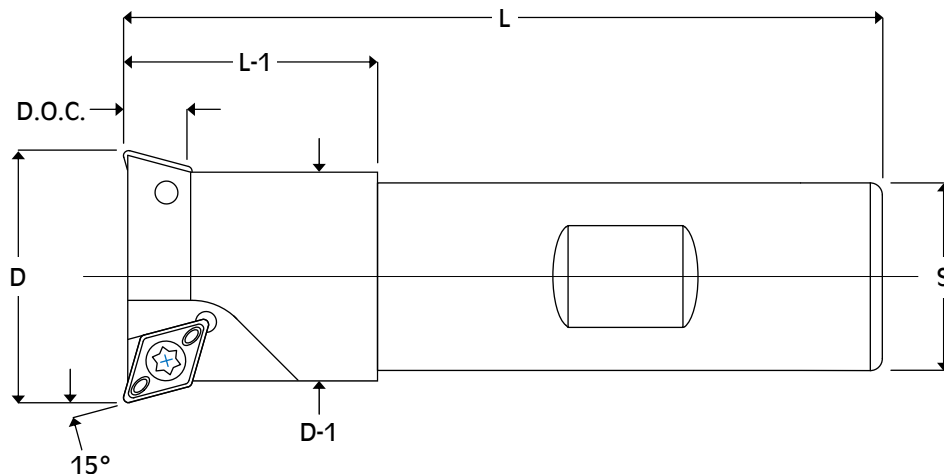

Tool Info.

Tool #	D	D-1	Flutes	L	L-1	D.O.C.	S	Inserts
DT-1015	1.000	.830	2	3.000	1.000	.255	.750	DDEB-2151P
DT-1515	1.500	1.250	2	3.250	1.250	.370	.750	DPEB-3252P

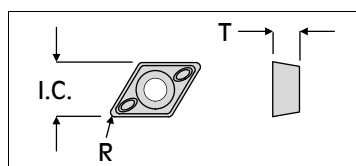

Insert Info

DDEB-2151P	
Grades	X33 X40
I.C.	.250
T	.095
R	.015
Screw	314T
Wrench	T-8

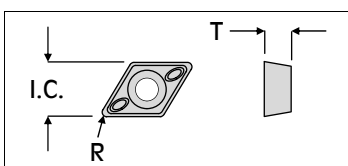

Insert Info

DPEB-3252P	
Grade	X33
I.C.	.375
T	.160
R	.031
Screw	538T
Wrench	T-10

Speed and Feed Info.

Material	S.F.M.	I.P.T.
Mild & Low Carbon Steel Ex. 1018, 1020, 1117, 1141, 12L14	800 - 1200	.002 - .005
High Carbon & Alloy Steel Ex. 1045, 4140, 4340, 52100, 8620	500 - 800	.002 - .005
Lower Carbon Tool Steel Ex. P-20, H-13, S-7	400 - 700	.002 - .005
Tool Steel Ex. A-2, A-6, D-2, M-2	300 - 600	.002 - .005
Stainless Steel Ex. 304, 316, 420, 15-5PH, 17-4PH	300 - 600	.002 - .005
Iron Ex. Cast, Ductile, Nodular	600 - 1000	.002 - .006
Nickel & Titanium Alloy Ex. Inconel, Hastelloy, Ti-6AL-4V	120 - 180	.001 - .002
Non-Ferrous Metal Ex. Aluminum, Bronze, Brass	1000 - 2500	.002 - .006

Mini Mills

Available Modifications

- Reduce Shank Diameters
- Coolant Thru

2 - 3 Day Delivery

Free Cutting for Faster Feed Rates

2 Cutting Edges Per Insert



Applications

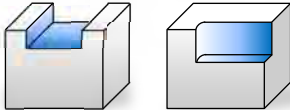

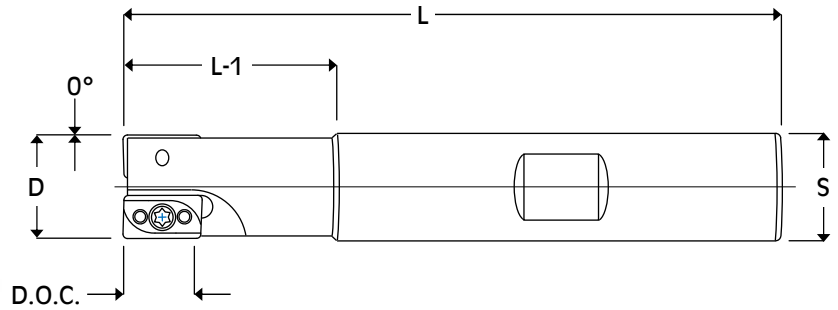

Tool Info.

Tool #	D	Flutes	L	L-1	D.O.C.	S	Screw	Wrench	Insert
MM-250	.250	1	2.030	.500	.218	.375	164T	T-6	MGH-151 MGH-1510 MGH-1511
XMM-250	.250	1	3.000	.680	.218	.375			
MM-281	.281	1	2.030	.500	.218	.375			
MM-312	.312	1	2.030	.500	.218	.375			
MM-343	.343	1	2.250	.720	.218	.375			
MM-375	.375	2	2.250	.720	.218	.375			
XMM-375	.375	1	3.500	1.970	.218	.375			
MM-406	.406	2	2.500	.750	.218	.500			
MM-437	.437	2	2.500	.750	.218	.500			
MM-468	.468	2	2.500	.750	.218	.500			
MM-500	.500	3	2.500	.750	.218	.500			
XMM-500	.500	2	4.000	2.250	.218	.500			
MM-625	.625	4	2.625	.750	.218	.625			
MM-750	.750	5	2.750	.750	.218	.750			

Speed and Feed Info.

Material	S.F.M.	I.P.T.
Mild & Low Carbon Steel Ex. 1018, 1020, 1117, 1141, 12L14	800 - 1200	.001 - .002
High Carbon & Alloy Steel Ex. 1045, 4140, 4340, 52100, 8620	500 - 800	.001 - .002
Lower Carbon Tool Steel Ex. P-20, H-13, S-7	400 - 700	.001 - .002
Tool Steel Ex. A-2, A-6, D-2, M-2	300 - 600	.001 - .002
Stainless Steel Ex. 304, 316, 420, 15-5PH, 17-4PH	300 - 600	.001 - .002
Iron Ex. Cast, Ductile, Nodular	600 - 1000	.001 - .002
Nickel & Titanium Alloy Ex. Inconel, Hastelloy, Ti-6AL-4V	120 - 180	.001
Non-Ferrous Metal Ex. Aluminum, Bronze, Brass	1000 - 2500	.001 - .002

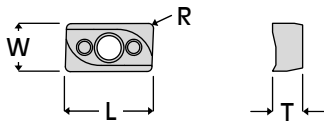

Insert Info.

Insert #	W	L	T	R	Grades
MGH-151	.170	.250	.080	.002	B1M X33
MGH-1510	.170	.250	.080	.008	X33
MGH-1511	.170	.250	.080	.015	X33

Radius Mills

- .015 - .031 - .062 - .093 - .125 Radius Inserts can be used in the same Tool Body
- .156 - .187 - .218 - .250 Radius Inserts can be used in the same Tool Body

.015 - .250 Radius Inserts Available

Available Modifications

- Reduce Shank Diameters
- Coolant Thru

2 - 3 Day Delivery

Extended Length Tools Available

Cuts a Square Shoulder within .001

Available in a Shank Style
or Shell Mount Style

Applications

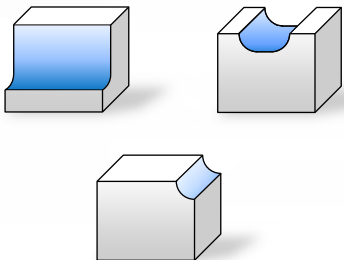

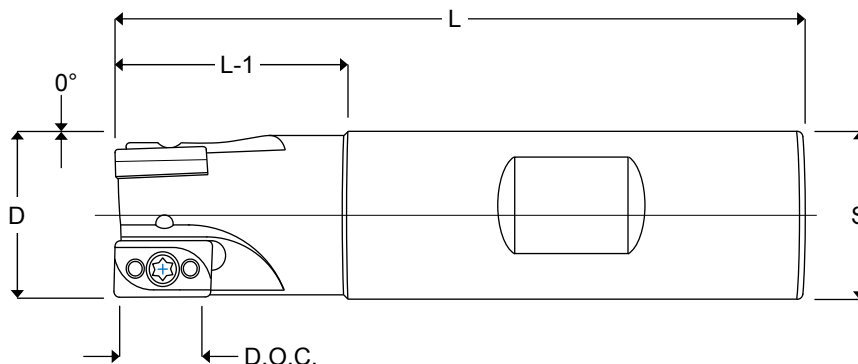

.015 - .031 - .047 - .062 Radius

Tool Info.

Tool #	D	Flutes	L	L-1	D.O.C.	S	Screw	Wrench	Inserts
RMS-375	.375	1	2.625	.340	.310	.500	314T	T-8	MGH-2321 MGH-2322 MGH-2323 MGH-2324
RMS-500	.500	1	2.750	.750	.380	.500			
XRM-500	.500	1	3.625	1.500	.380	.750			
RMS-625	.625	2	3.000	1.000	.380	.625			
XRM-625	.625	1	3.875	1.875	.380	.750			
RMS-750	.750	3	3.000	1.000	.380	.750			
XRM-750	.750	2	4.250	2.250	.380	.750			
RMS-875	.875	3	3.250	1.250	.380	.750			
RMS-1000	1.000	4	3.250	1.250	.380	.750			

Speed and Feed Info.

Material	S.F.M.	.375-.625 Dia. I.P.T.	.750 - 1.000 Dia. I.P.T.
Mild & Low Carbon Steel Ex. 1018, 1020, 1117, 1141, 12L14	800 - 1200	.002 - .003	.002 - .006
High Carbon & Alloy Steel Ex. 1045, 4140, 4340, 52100, 8620	500 - 800	.002 - .003	.002 - .005
Lower Carbon Tool Steel Ex. P-20, H-13, S-7	400 - 700	.002 - .003	.002 - .005
Tool Steel Ex. A-2, A-6, D-2, M-2	300 - 600	.002 - .003	.002 - .004
Stainless Steel Ex. 304, 316, 420, 15-5PH, 17-4PH	300 - 600	.002 - .003	.002 - .004
Iron Ex. Cast, Ductile, Nodular	600 - 1000	.002 - .003	.003 - .006
Nickel & Titanium Alloy Ex. Inconel, Hastelloy, Ti-6AL-4V	120 - 180	.001 - .002	.001 - .002
Non-Ferrous Metal Ex. Aluminum, Bronze, Brass	1000 - 2500	.002 - .004	.003 - .007

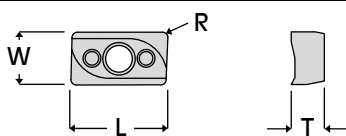

Insert Info.

Insert #	W	L	T	R	Grades
MGH-2321	.250	.400	.140	.015	X33
MGH-2322	.250	.400	.140	.031	B1M X33
MGH-2323	.250	.400	.140	.047	X33
MGH-2324	.250	.400	.140	.062	X33

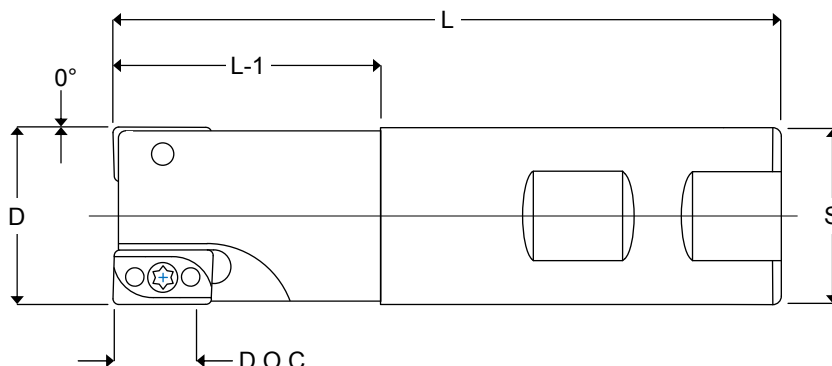

.015 - .031 - .062 - .093 - .125 Radius

Tool Info.

Tool #	D	Flutes	L	L-1	D.O.C.	S	Screw	Wrench	Inserts
RM-750A	.750	2	3.250	1.250	.540	.750	560T	T-10	MGH-531A MGH-532A MGH-534A MGH-536A MGH-538A
RM-980A	.980	2	3.750	1.500	.540	1.000			
RM-1000A-2	1.000	2	3.750	1.500	.540	1.000			
RM-1000A-3	1.000	3	3.750	1.500	.540	1.000			
XRM-1000A	1.000	2	5.250	3.000	.540	1.000			
RM-1250A-3	1.250	3	4.000	.875	.540	1.000			
RM-1250A-4	1.250	4	4.000	.875	.540	1.000			
RM-1500A-4	1.500	4	4.000	.875	.540	1.000			
RM-1500A-5	1.500	5	4.000	.875	.540	1.000			

Speed and Feed Info.

Material	S.F.M.	I.P.T.
Mild & Low Carbon Steel Ex. 1018, 1020, 1117, 1141, 12L14	800 - 1200	.002 - .006
High Carbon & Alloy Steel Ex. 1045, 4140, 4340, 52100, 8620	500 - 800	.002 - .005
Lower Carbon Tool Steel Ex. P-20, H-13, S-7	400 - 700	.002 - .005
Tool Steel Ex. A-2, A-6, D-2, M-2	300 - 600	.002 - .004
Stainless Steel Ex. 304, 316, 420, 15-5PH, 17-4PH	300 - 600	.002 - .004
Iron Ex. Cast, Ductile, Nodular	600 - 1000	.003 - .006
Nickel & Titanium Alloy Ex. Inconel, Hastelloy, Ti-6AL-4V	120 - 180	.001 - .002
Non-Ferrous Metal Ex. Aluminum, Bronze, Brass	1000 - 2500	.003 - .007

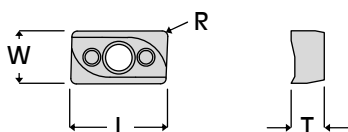

Insert Info.

Insert #	W	L	T	R	Grades
MGH-531A	.313	.562	.190	.015	X33
MGH-532A	.313	.562	.190	.031	BIM X33
MGH-534A	.313	.562	.190	.062	X33
MGH-536A	.313	.562	.190	.093	X33
MGH-538A	.313	.562	.190	.125	X33

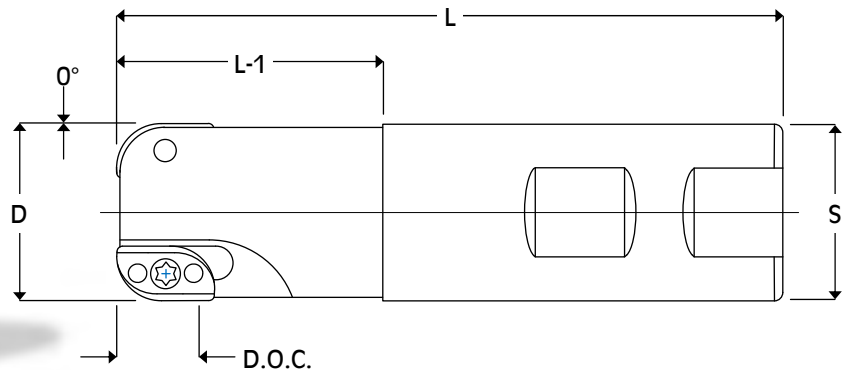

.156 - .187 - .218 - .250 Radius

Tool Info.

Tool #	D	Flutes	L	L-1	D.O.C.	S	Screw	Wrench	Inserts
RM-750B	.750	2	3.250	1.250	.540	.750	560T	T-10	MGH-5310B MGH-5312B MGH-5314B MGH-5316B
RM-980B	.980	2	3.750	1.500	.540	1.000			
RM-1000B-2	1.000	2	3.750	1.500	.540	1.000			
RM-1000B-3	1.000	3	3.750	1.500	.540	1.000			
XRM-1000B	1.000	2	5.250	3.000	.540	1.000			
RM-1250B-3	1.250	3	4.000	.875	.540	1.000			
RM-1250B-4	1.250	4	4.000	.875	.540	1.000			
RM-1500B-4	1.500	4	4.000	.875	.540	1.000			
RM-1500B-5	1.500	5	4.000	.875	.540	1.000			

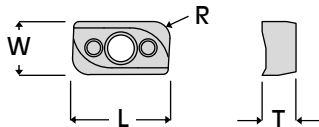

Insert Info.

Insert #	W	L	T	R	Grade
MGH-5310B	.313	.562	.190	.156	X33
MGH-5312B	.313	.562	.190	.187	X33
MGH-5314B	.313	.562	.190	.218	X33
MGH-5316B	.313	.562	.190	.250	X33

Speed and Feed Info.

Material	S.F.M.	I.P.T.
Mild & Low Carbon Steel Ex. 1018, 1020, 1117, 1141, 12L14	800 - 1200	.002 - .006
High Carbon & Alloy Steel Ex. 1045, 4140, 4340, 52100, 8620	500 - 800	.002 - .005
Lower Carbon Tool Steel Ex. P-20, H-13, S-7	400 - 700	.002 - .005
Tool Steel Ex. A-2, A-6, D-2, M-2	300 - 600	.002 - .004
Stainless Steel Ex. 304, 316, 420, 15-5PH, 17-4PH	300 - 600	.002 - .004
Iron Ex. Cast, Ductile, Nodular	600 - 1000	.003 - .006
Nickel & Titanium Alloy Ex. Inconel, Hastelloy, Ti-6AL-4V	120 - 180	.001 - .002
Non-Ferrous Metal Ex. Aluminum, Bronze, Brass	1000 - 2500	.003 - .007

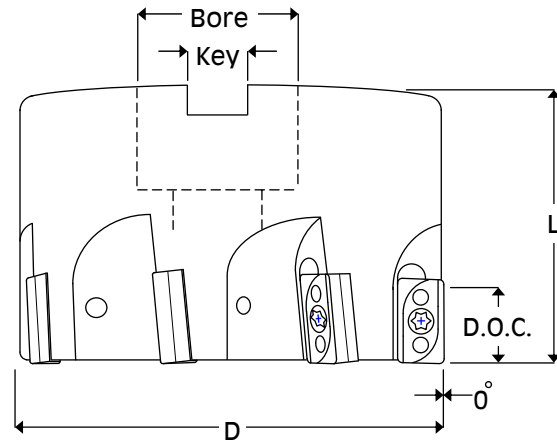

A Series .015 - .031 - .062 - .093 - .125 Radius

Tool Info.

Tool #	D	Flutes	L	D.O.C.	Bore	Key	Screw	Wrench	Inserts
RM-2000A	2.000	6	1.625	.540	.750	.312	560T	T-10	MGH-531A
RM-2500A	2.500	7	1.625	.540	1.000	.375			MGH-532A
RM-3000A	3.000	8	1.750	.540	1.000	.375			MGH-534A MGH-536A MGH-538A

B Series .156 - .187 - .218 - .250 Radius

Tool Info.

Tool #	D	Flutes	L	D.O.C.	Bore	Key	Screw	Wrench	Inserts
RM-2000B	2.000	6	1.625	.540	.750	.312	560T	T-10	MGH-5310B
RM-2500B	2.500	7	1.625	.540	1.000	.375			MGH-5312B
RM-3000B	3.000	8	1.750	.540	1.000	.375			MGH-5314B MGH-5316B

For Larger Diameters, Refer to Universal Mills on Page 133

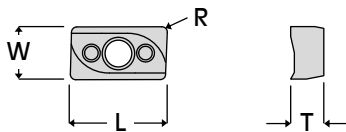

Insert Info.

Insert #	W	L	T	R	Grades
MGH-531A	.313	.562	.190	.015	X33
MGH-532A	.313	.562	.190	.031	B1M X33
MGH-534A	.313	.562	.190	.062	X33
MGH-536A	.313	.562	.190	.093	X33
MGH-538A	.313	.562	.190	.125	X33
MGH-5310B	.313	.562	.190	.156	X33
MGH-5312B	.313	.562	.190	.187	X33
MGH-5314B	.313	.562	.190	.218	X33
MGH-5316B	.313	.562	.190	.250	X33

Speed and Feed Info.

Material	S.F.M.	I.P.T.
Mild & Low Carbon Steel Ex. 1018, 1020, 1117, 1141, 12L14	800 - 1200	.002 - .006
High Carbon & Alloy Steel Ex. 1045, 4140, 4340, 52100, 8620	500 - 800	.002 - .005
Lower Carbon Tool Steel Ex. P-20, H-13, S-7	400 - 700	.002 - .005
Tool Steel Ex. A-2, A-6, D-2, M-2	300 - 600	.002 - .004
Stainless Steel Ex. 304, 316, 420, 15-5PH, 17-4PH	300 - 600	.002 - .004
Iron Ex. Cast, Ductile, Nodular	600 - 1000	.003 - .006
Nickel & Titanium Alloy Ex. Inconel, Hastelloy, Ti-6AL-4V	120 - 180	.001 - .002
Non-Ferrous Metal Ex. Aluminum, Bronze, Brass	1000 - 2500	.003 - .007

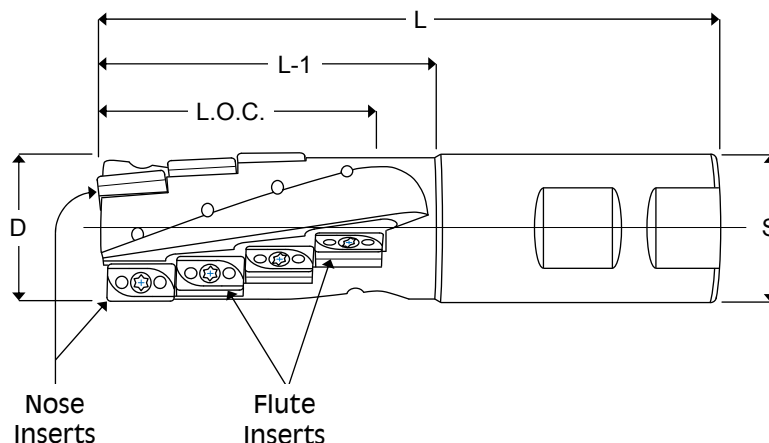

Tool Info.

Tool #	D	Flutes	Inserts	L	L-1	L.O.C.	S	Nose Inserts	Flute Inserts	Screw	Wrench
RML-1000A	1.000	2-1 Effective	6	4.250	2.000	1.700	1.000	MGH-531A	MGH-532A	560T	T-10
RML-1250A	1.250	3-1.5 Effective	12	5.000	2.750	2.250	1.250	MGH-532A			
RML-1500A	1.500	4-2 Effective	20	5.500	3.250	2.800	1.250	MGH-534A			
RML-2000A	2.000	4-2 Effective	24	6.687	4.000	3.400	1.500	MGH-536A			
RML-1000B	1.000	2-1 Effective	6	4.250	2.000	1.700	1.000	MGH-538A			
RML-1250B	1.250	3-1.5 Effective	12	5.000	2.750	2.250	1.250	MGH-5310B			
RML-1500B	1.500	4-2 Effective	20	5.500	3.250	2.800	1.250	MGH-5312B			
RML-2000B	2.000	4-2 Effective	24	6.687	4.000	3.400	1.500	MGH-5314B			
								MGH-5316B			

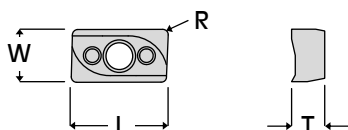

Insert Info.

Insert #	W	L	T	R	Grades
MGH-531A	.313	.562	.190	.015	X33
MGH-532A	.313	.562	.190	.031	BIM X33
MGH-534A	.313	.562	.190	.062	X33
MGH-536A	.313	.562	.190	.093	X33
MGH-538A	.313	.562	.190	.125	X33
MGH-5310B	.313	.562	.190	.156	X33
MGH-5312B	.313	.562	.190	.187	X33
MGH-5314B	.313	.562	.190	.218	X33
MGH-5316B	.313	.562	.190	.250	X33

Speed and Feed Info.

Material	S.F.M.	I.P.T.
Mild & Low Carbon Steel Ex. 1018, 1020, 1117, 1141, 12L14	400 - 800	.003 - .008
High Carbon & Alloy Steel Ex. 1045, 4140, 4340, 52100, 8620	300 - 500	.002 - .006
Lower Carbon Tool Steel Ex. P-20, H-13, S-7	300 - 500	.002 - .006
Tool Steel Ex. A-2, A-6, D-2, M-2	300 - 500	.002 - .004
Stainless Steel Ex. 304, 316, 420, 15-5PH, 17-4PH	300 - 500	.002 - .004
Iron Ex. Cast, Ductile, Nodular	400 - 800	.003 - .009
Nickel & Titanium Alloy Ex. Inconel, Hastelloy, Ti-6AL-4V	100 - 200	.001 - .003
Non-Ferrous Metal Ex. Aluminum, Bronze, Brass	800 - 1200	.004 - .010

Keli-Mills

High Shear Long Edge Mills

- Great Tool For Cast Iron, Titanium, Inconel, Stainless Steel & Aluminum

Available Modifications

- Reduce Shank Diameters
- Coolant Thru

2 - 3 Day Delivery

.031 - .062 Radius Inserts Available

Long Edge Tools Available

Cuts a Square Shoulder within .001

Available in a Shank Style
or Shell Mount Style

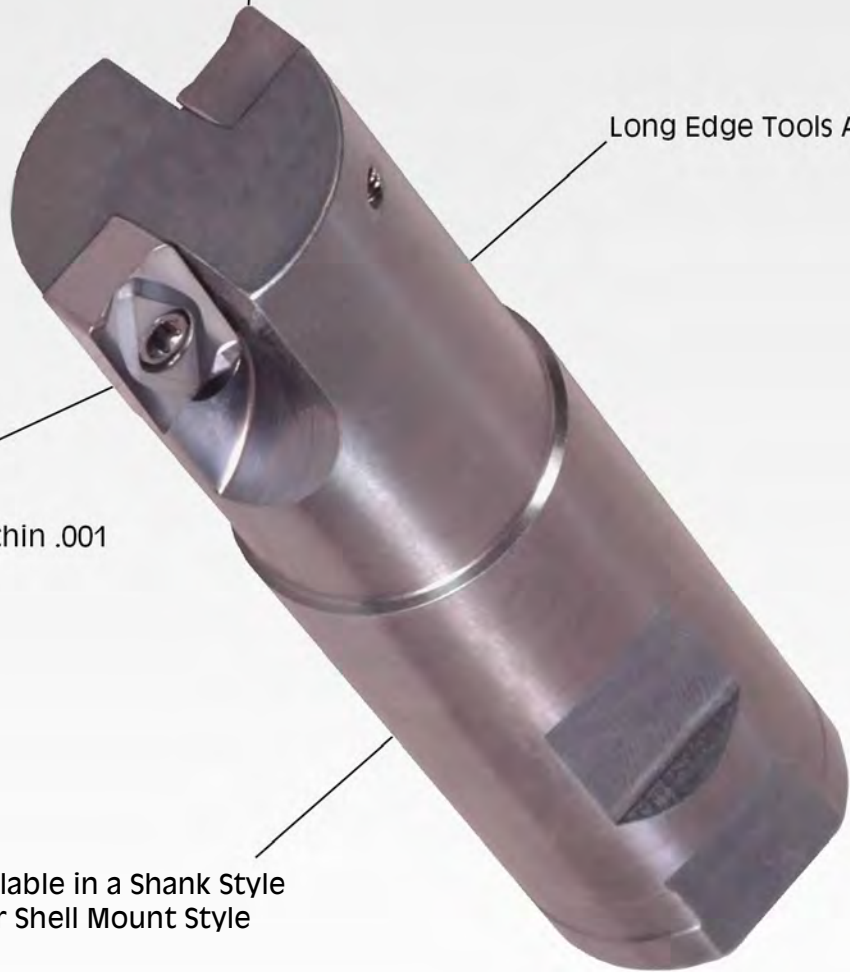

Applications

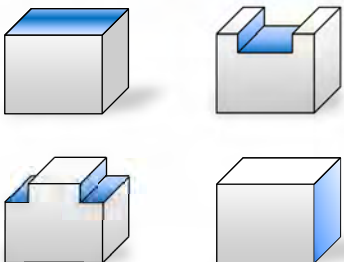

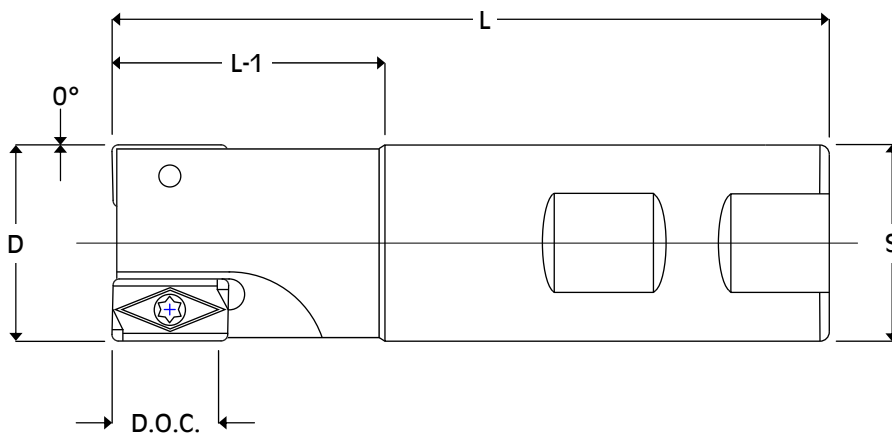

Tool Info.

Tool #	D	Flutes	L	L-1	D.O.C.	S	Screw	Wrench	Inserts
KE-1000-2	1.000	2	3.750	1.500	.580	1.000	560T	T-10	LPMT-52-532 LPMT-52-533 LPMT-52-534
KE-1000-3	1.000	3	3.750	1.500	.580				
KE-1250-3	1.250	3	4.000	.875	.580				
KE-1250-4	1.250	4	4.000	.875	.580				
KE-1500-4	1.500	4	4.000	.875	.580				
KE-1500-5	1.500	5	4.000	.875	.580				

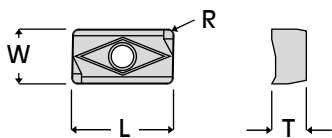

Insert Info.

Insert #	W	L	T	R	Grades
LPMT-52-532	.320	.600	.208	.031	B1M X33
LPMT-52-533	.320	.600	.208	.047	X33
LPMT-52-534	.320	.600	.208	.062	X33

Speed and Feed Info.

Material	S.F.M.	I.P.T.
Stainless Steel Ex. 304, 316, 420, 15-5PH, 17-4PH	300 - 600	.002 - .004
Iron Ex. Cast, Ductile, Nodular	600 - 1200	.003 - .007
Nickel & Titanium Alloy Ex. Inconel, Hastelloy, Ti-6AL-4V	120 - 180	.001 - .004
Non-Ferrous Metal Ex. Aluminum, Bronze, Brass	1000 - 2500	.005 - .010

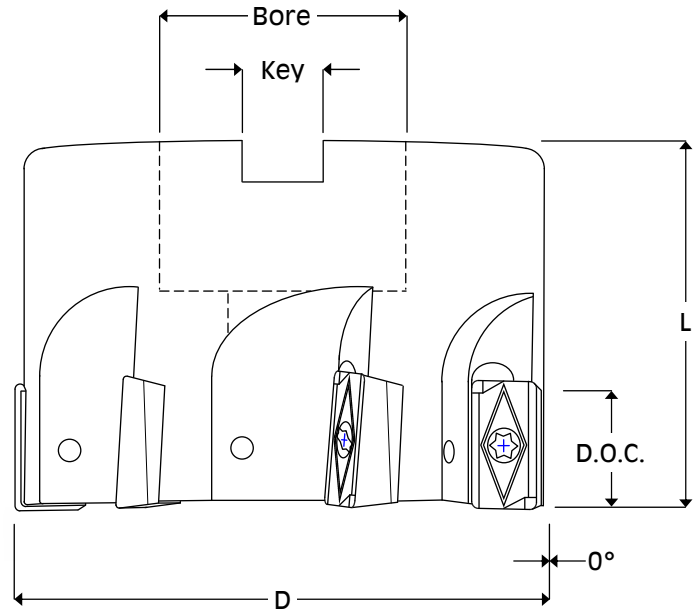
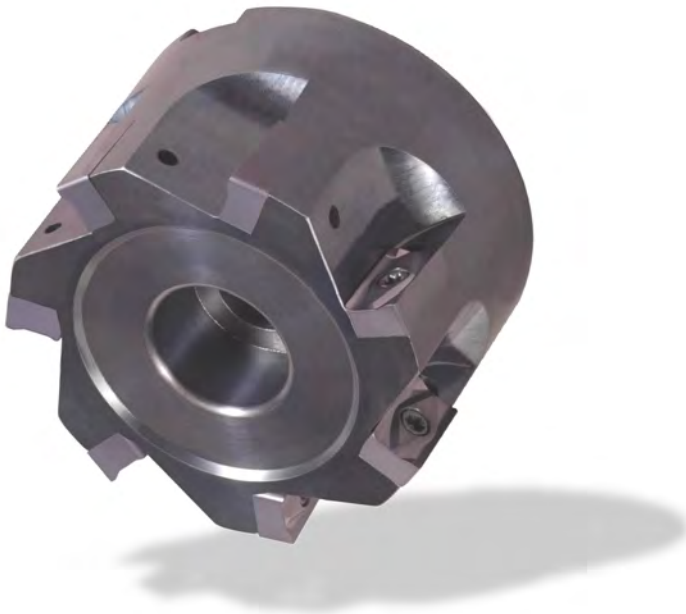

Tool Info.

Tool #	D	Flutes	L	D.O.C.	Bore	Key	Screw	Wrench	Inserts
KE-2000	2.000	6	1.625	.580	.750	.312	560T	T-10	LPMT-52-532
KE-2500	2.500	7	1.625	.580	1.000	.375			LPMT-52-533
KE-3000	3.000	8	1.750	.580	1.250	.500			LPMT-52-534

For Larger Diameters, Refer to Universal Mills on Page 133

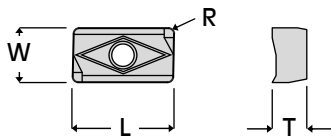

Insert Info.

Insert #	W	L	T	R	Grades
LPMT-52-532	.320	.600	.208	.031	B1M X33
LPMT-52-533	.320	.600	.208	.047	X33
LPMT-52-534	.320	.600	.208	.062	X33

Speed and Feed Info.

Material	S.F.M.	I.P.T.
Stainless Steel Ex. 304, 316, 420, 15-5PH, 17-4PH	300 - 600	.002 - .004
Iron Ex. Cast, Ductile, Nodular	600 - 1200	.003 - .007
Nickel & Titanium Alloy Ex. Inconel, Hastelloy, Ti-6AL-4V	120 - 180	.001 - .004
Non-Ferrous Metal Ex. Aluminum, Bronze, Brass	1000 - 2500	.005 - .010

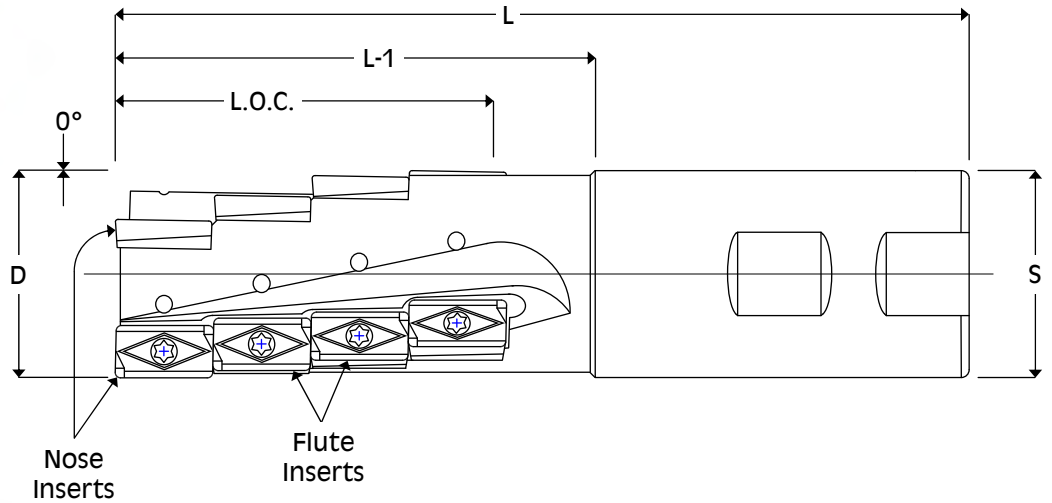

Tool Info.

Tool #	D	Flutes	Inserts	L	L-1	L.O.C.	S	Nose Inserts	Flute In- sert	Screw	Wrench
KEL-1000	1.000	2-1 Effective	6	4.500	2.250	1.800	1.000	LPMT-52-532			
KEL-1250	1.250	3-1.5 Effective	12	5.125	2.880	2.400	1.250	LPMT-52-533	LPMT-52-532	560T	T-10
KEL-1500	1.500	3-1.5 Effective	15	5.750	3.500	3.000	1.250	LPMT-52-534			

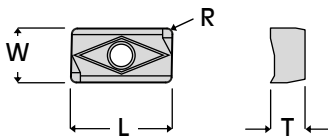

Insert Info.

Insert #	W	L	T	R	Grades
LPMT-52-532	.320	.600	.208	.031	B1M X33
LPMT-52-533	.320	.600	.208	.047	X33
LPMT-52-534	.320	.600	.208	.062	X33

Speed and Feed Info.

Material	S.F.M.	I.P.T.
Stainless Steel Ex. 304, 316, 420, 15-5PH, 17-4PH	300 - 500	.002 - .004
Iron Ex. Cast, Ductile, Nodular	400 - 800	.004 - .008
Nickel & Titanium Alloy Ex. Inconel, Hastelloy, Ti-6AL-4V	100 - 200	.001 - .003
Non-Ferrous Metal Ex. Aluminum, Bronze, Brass	800 - 1200	.005 - .010

Serators

Long Edge Roughing Mills



Applications



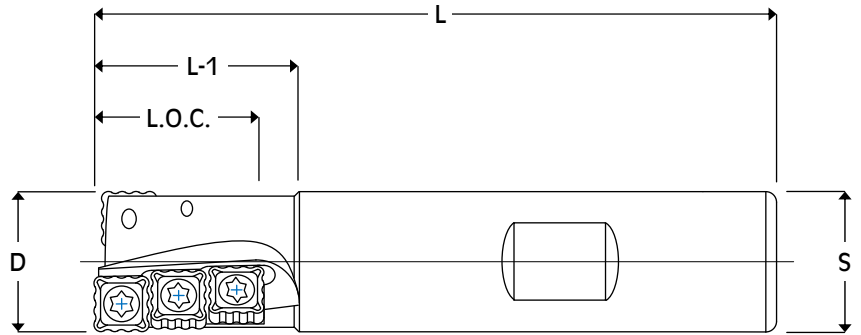

Tool Info.										
Tool #	D	Flutes	Inserts	L	L-1	L.O.C.	S	Screw	Wrench	Inserts
S-625	.615	2-1 Effective	6	3.000	.900	.750	.625	314T	T-8	SNMC-222B
S-750	.740	2-1 Effective	8	3.375	1.125	1.000	.750			SNMC-221P

IMPORTANT

High Pressure Flood Coolant or Air Blast Required to Disperse Chip and Cool the Tool

Recutting Chips Will Cause Early Insert Failure

Positive Top Insert				
Insert Info.				
Insert #	I.C.	T	R	Grade
SNMC-222B	.250	.125	.031	X33

Positive Top Insert				
Insert Info.				
Insert #	I.C.	T	R	Grade
SNMC-221P	.250	.125	.015	X33

Speed and Feed Info.		
Material	S.F.M.	I.P.T.
Mild & Low Carbon Steel Ex. 1018, 1020, 1117, 1141, 12L14	600 - 1200	.002 - .003
High Carbon & Alloy Steel Ex. 1045, 4140, 4340, 52100, 8620	500 - 800	.002 - .003
Lower Carbon Tool Steel Ex. P-20, H-13, S-7	400 - 700	.002 - .003
Tool Steel Ex. A-2, A-6, D-2, M-2	300 - 600	.002 - .003
Stainless Steel Ex. 304, 316, 420, 15-5PH, 17-4PH	300 - 600	.002 - .003
Iron Ex. Cast, Ductile, Nodular	600 - 1000	.003 - .004
Nickel & Titanium Alloy Ex. Inconel, Hastelloy, Ti-6AL-4V	100 - 180	.001 - .002

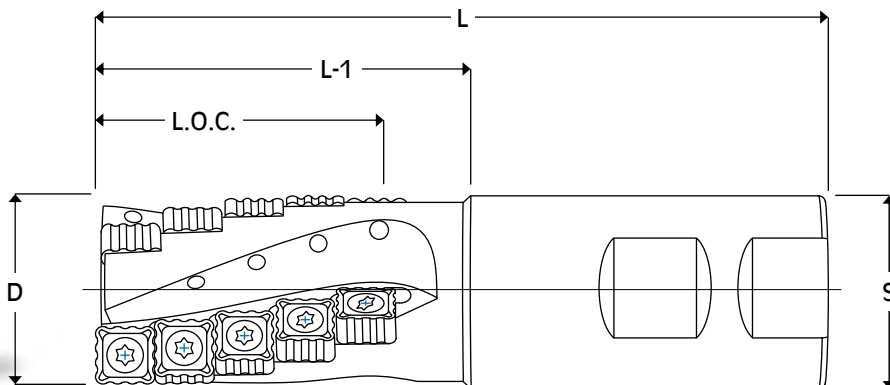

Tool Info.

Tool #	D	Flutes	Inserts	L	L-1	L.O.C.	S	Screw	Wrench	Inserts
S-100S	.985	2-1 Effective	4	3.125	1.125	.780	.750	538T	T-10	SNMC-333B SNGC-333H SNMC-332P
S-100M	.985	2-1 Effective	6	3.625	1.375	1.125	1.000			
S-100	.985	2-1 Effective	8	4.000	1.750	1.500	1.000			
S-125S	1.235	3-1.5 Effective	9	3.750	1.500	1.125	1.000			
S-125	1.235	3-1.5 Effective	15	4.625	2.375	1.900	1.250			
S-125L	1.235	2-1 Effective	16	5.625	3.375	3.062	1.250			
S-150S	1.485	3-1.5 Effective	9	3.875	1.625	1.125	1.000			
S-150	1.485	3-1.5 Effective	18	4.875	2.500	2.250	1.250			
S-150L	1.485	3-1.5 Effective	33	7.250	4.625	4.200	1.500			

Positive Top Insert

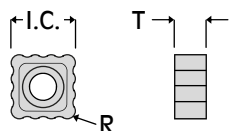

Insert #	I.C.	T	R	Grade
SNMC-333B	.375	.187	.047	X33

Positive Top Insert

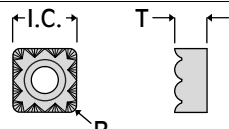

Insert #	I.C.	T	R	Grade
SNGC-333H	.375	.187	.047	X33

Positive Top Insert

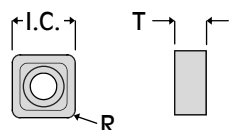

Insert #	I.C.	T	R	Grade
SNMC-332P	.375	.187	.031	X33

IMPORTANT

High Pressure Flood Coolant or Air Blast Required to Disperse Chip and Cool the Tool

Recutting Chips Will Cause Early Insert Failure

Speed and Feed Info.

Material	S.F.M.	I.P.T.
Mild & Low Carbon Steel Ex. 1018, 1020, 1117, 1141, 12L14	600 - 1200	.002 - .006
High Carbon & Alloy Steel Ex. 1045, 4140, 4340, 52100, 8620	500 - 800	.002 - .004
Lower Carbon Tool Steel Ex. P-20, H-13, S-7	400 - 700	.002 - .004
Tool Steel Ex. A-2, A-6, D-2, M-2	300 - 600	.002 - .004
Stainless Steel Ex. 304, 316, 420, 15-5PH, 17-4PH	300 - 600	.002 - .004
Iron Ex. Cast, Ductile, Nodular	600 - 1000	.003 - .006
Nickel & Titanium Alloy Ex. Inconel, Hastelloy, Ti-6AL-4V	100 - 180	.001 - .003

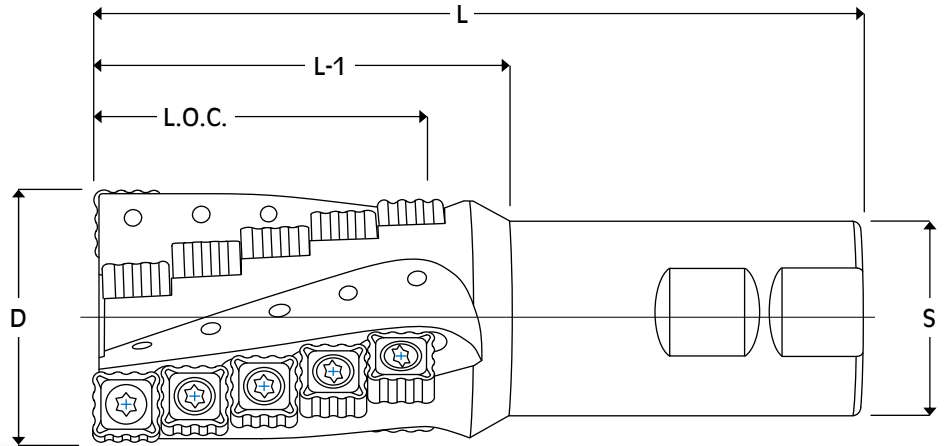
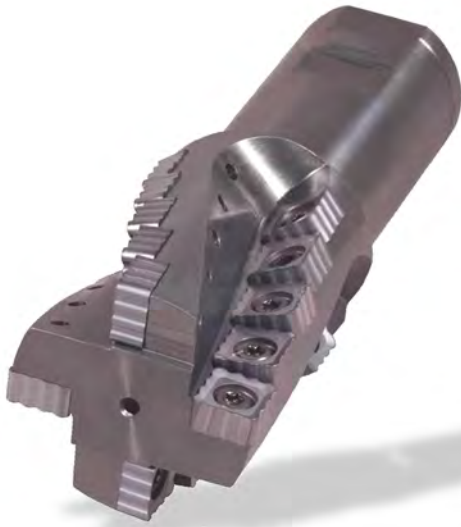

Tool Info.

Tool #	D	Flutes	Inserts	L	L-1	L.O.C.	S	Screw	Wrench	Inserts
S-200	1.980	4-2 Effective	20	5.750	3.125	2.550	1.500	838T	T-20	SNMC-444B SNGC-444H SNMC-443P

Positive Top Insert

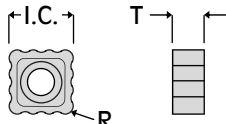

Insert #	I.C.	T	R	Grade
SNMC-444B	.500	.250	.062	X33

Positive Top Insert

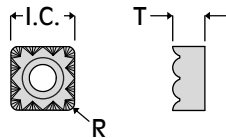

Insert #	I.C.	T	R	Grade
SNGC-444H	.500	.250	.062	X33

Positive Top Insert

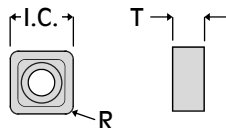

Insert #	I.C.	T	R	Grades
SNMC-443P	.500	.250	.047	A9M X33

IMPORTANT

High Pressure Flood Coolant or Air Blast Required to Disperse Chip and Cool the Tool

Recutting Chips Will Cause Early Insert Failure

Speed and Feed Info.

Material	S.F.M.	I.P.T.
Mild & Low Carbon Steel Ex. 1018, 1020, 1117, 1141, 12L14	600 - 1200	.002 - .006
High Carbon & Alloy Steel Ex. 1045, 4140, 4340, 52100, 8620	500 - 800	.002 - .004
Lower Carbon Tool Steel Ex. P-20, H-13, S-7	400 - 700	.002 - .004
Tool Steel Ex. A-2, A-6, D-2, M-2	300 - 600	.002 - .004
Stainless Steel Ex. 304, 316, 420, 15-5PH, 17-4PH	300 - 600	.002 - .004
Iron Ex. Cast, Ductile, Nodular	600 - 1000	.003 - .006
Nickel & Titanium Alloy Ex. Inconel, Hastelloy, Ti-6AL-4V	100 - 180	.001 - .003

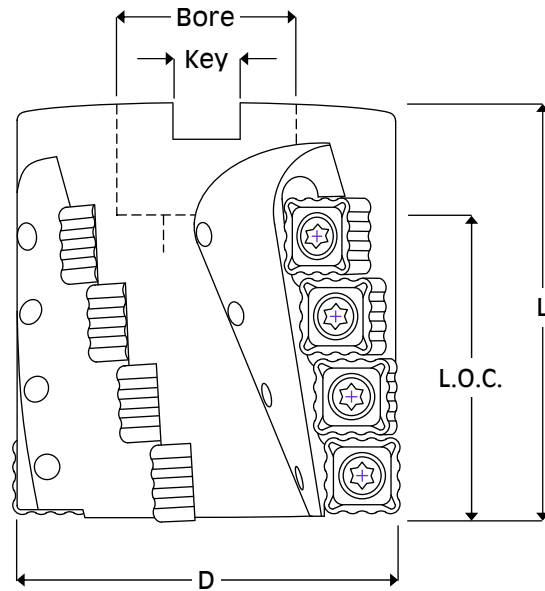

Tool Info.

Tool #	D	Flutes	Inserts	L	L.O.C.	Bore	Key	Screw	Wrench	Inserts
S-200S	1.980	4-2 Effective	16	2.000	1.500	.750	.312	538T	T-10	SNMC-333B SNGC-333H SNMC-332P
S-250S	2.480	4-2 Effective	16	2.625	2.000	1.250	.500	838T	T-20	SNMC-444B SNGC-444H SNMC-443P
S-300S	2.980	4-2 Effective	20	3.250	2.500	1.500	.625			
S-400S	3.980	6-3 Effective	30	3.290	2.500	1.500	.625			

Positive Top Inserts

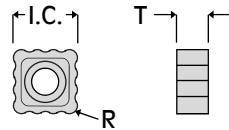

Insert #	I.C.	T	R	Grade
SNMC-333B	.375	.187	.047	X33
SNMC-444B	.500	.250	.062	X33

Positive Top Inserts

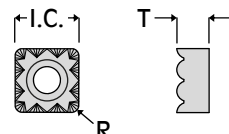

Insert #	I.C.	T	R	Grade
SNGC-333H	.375	.187	.047	X33
SNGC-444H	.500	.250	.062	X33

Positive Top Inserts

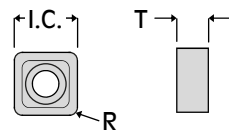

Insert #	I.C.	T	R	Grades
SNMC-332P	.375	.187	.031	X33
SNMC-443P	.500	.250	.047	A9M X33

IMPORTANT

High Pressure Flood Coolant or Air Blast Required to Disperse Chip and Cool the Tool

Recutting Chips Will Cause Early Insert Failure

Speed and Feed Info.

Material	S.F.M.	I.P.T.
Mild & Low Carbon Steel Ex. 1018, 1020, 1117, 1141, 12L14	600 - 1200	.002 - .006
High Carbon & Alloy Steel Ex. 1045, 4140, 4340, 52100, 8620	500 - 800	.002 - .004
Lower Carbon Tool Steel Ex. P-20, H-13, S-7	400 - 700	.002 - .004
Tool Steel Ex. A-2, A-6, D-2, M-2	300 - 600	.002 - .004
Stainless Steel Ex. 304, 316, 420, 15-5PH, 17-4PH	300 - 600	.002 - .004
Iron Ex. Cast, Ductile, Nodular	600 - 1000	.003 - .006
Nickel & Titanium Alloy Ex. Inconel, Hastelloy, Ti-6AL-4V	100 - 180	.001 - .003

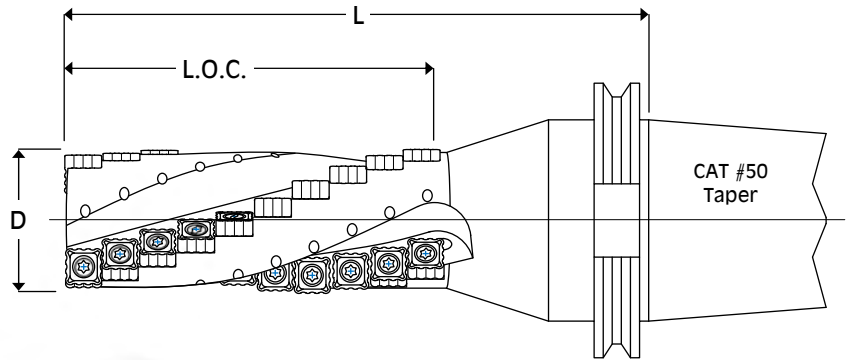

Tool Info.

Tool #	D	Flutes	Inserts	L	L.O.C.	Screw	Wrench	Inserts
V50-203	1.980	4-2 Effective	28	6.000	3.600	838T	T-20	SNMC-444B SNGC-444H SNMC-443P
V50-205	1.980	3-1.5 Effective	30	8.000	5.100			
V50-253	2.480	4-2 Effective	28	6.000	3.600			
V50-256	2.480	4-2 Effective	48	8.000	6.100			
V50-303	2.980	4-2 Effective	28	6.000	3.600			
V50-306	2.980	4-2 Effective	48	8.000	6.100			

Positive Top Insert

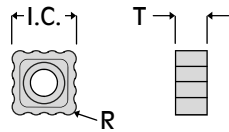

Insert #	I.C.	T	R	Grade
SNMC-444B	.500	.250	.062	X33

Positive Top Insert

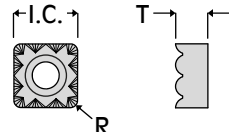

Insert #	I.C.	T	R	Grade
SNGC-444H	.500	.250	.062	X33

Positive Top Insert

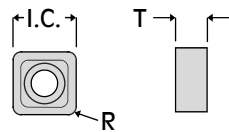

Insert #	I.C.	T	R	Grades
SNMC-443P	.500	.250	.047	A9M X33

IMPORTANT

High Pressure Flood Coolant or Air Blast Required to Disperse Chip and Cool the Tool

Recutting Chips Will Cause Early Insert Failure

Speed and Feed Info.

Material	S.F.M.	I.P.T.
Mild & Low Carbon Steel Ex. 1018, 1020, 1117, 1141, 12L14	600 - 1200	.002 - .006
High Carbon & Alloy Steel Ex. 1045, 4140, 4340, 52100, 8620	500 - 800	.002 - .004
Lower Carbon Tool Steel Ex. P-20, H-13, S-7	400 - 700	.002 - .004
Tool Steel Ex. A-2, A-6, D-2, M-2	300 - 600	.002 - .004
Stainless Steel Ex. 304, 316, 420, 15-5PH, 17-4PH	300 - 600	.002 - .004
Iron Ex. Cast, Ductile, Nodular	600 - 1000	.003 - .006
Nickel & Titanium Alloy Ex. Inconel, Hastelloy, Ti-6AL-4V	100 - 180	.001 - .003

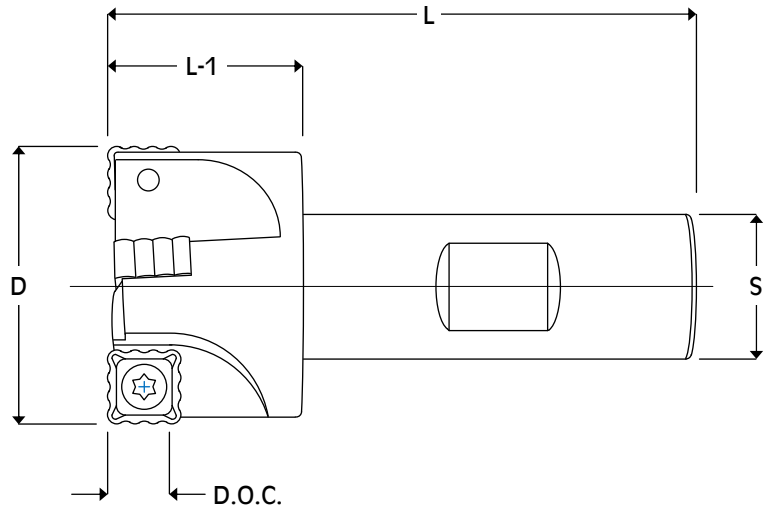

Tool Info.

Tool #	D	Flutes	Inserts	L	L-1	D.O.C.	S	Screw	Wrench	Inserts
SM-100	.990	2-1 Effective	2	3.000	1.000	.370	.750	538T	T-10	SNMC-333B SNMC-333H
SM-125	1.240	3-1.5 Effective	3							
SM-150	1.490	4-2 Effective	4							
SM-200	1.990	6-3 Effective	6							

For Larger Diameters, Refer to Universal Mills on Page 133

IMPORTANT

High Pressure Flood Coolant or Air Blast Required to Disperse Chip and Cool the Tool

Recutting Chips Will Cause Early Insert Failure

Speed and Feed Info.

Material	S.F.M.	I.P.T.
Mild & Low Carbon Steel Ex. 1018, 1020, 1117, 1141, 12L14	600 - 1200	.002 - .006
High Carbon & Alloy Steel Ex. 1045, 4140, 4340, 52100, 8620	500 - 800	.002 - .004
Lower Carbon Tool Steel Ex. P-20, H-13, S-7	400 - 700	.002 - .004
Tool Steel Ex. A-2, A-6, D-2, M-2	300 - 600	.002 - .004
Stainless Steel Ex. 304, 316, 420, 15-5PH, 17-4PH	300 - 600	.002 - .004
Iron Ex. Cast, Ductile, Nodular	600 - 1000	.003 - .006
Nickel & Titanium Alloy Ex. Inconel, Hastelloy, Ti-6AL-4V	100 - 180	.001 - .003

Positive Top Insert

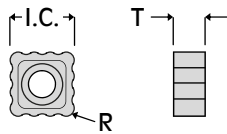

Insert #	I.C.	T	R	Grade
SNMC-333B	.375	.187	.047	X33

Positive Top Insert

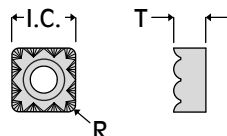

Insert #	I.C.	T	R	Grade
SNGC-333H	.375	.187	.047	X33

Super Alloy Mills

High Positive Square Shoulder Mills

Available Modifications

- Reduce Shank Diameters
- Coolant Thru

2 - 3 Day Delivery



Applications

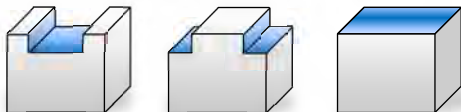

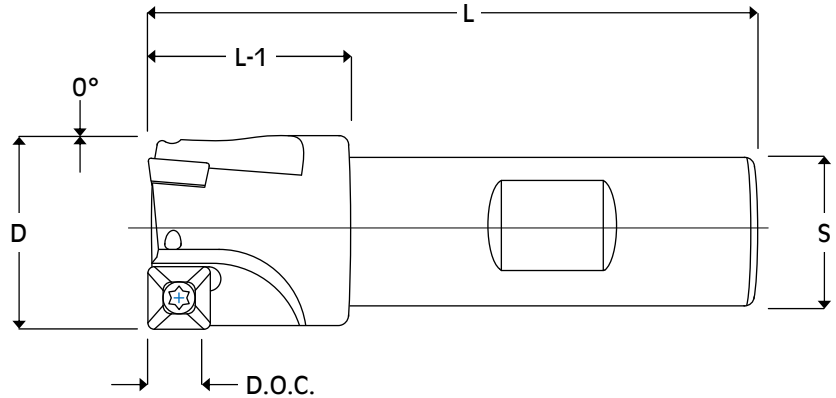

Tool Info.

Tool #	D	Flutes	L	L-1	D.O.C.	S	Screw	Wrench	Insert
SA-375	.375	1	2.250	.625	.235	.375	300T	T-8	SDEB-2151P
SA-500	.500	1	2.625	.625	.215	.500	300T	T-8	SPEB-222P
SA-625	.625	2	3.000	.875	.215	.625	314T	T-8	
SA-750	.750	2	3.000	1.000	.280	.750	314T	T-8	SPEB-2522P
SA-100	1.000	3	3.000	1.000	.280	.750	314T	T-8	
SA-125	1.250	3	3.250	1.250	.340	.750	538T	T-10	SPEB-332P
SA-125HS	1.250	2	3.500	1.250	.465	1.000	638T	T-15	SPEB-432PA
SA-150	1.500	3	3.250	1.250	.340	.750	538T	T-10	SPEB-332P
SA-150HS	1.500	3	3.500	1.250	.465	1.000	638T	T-15	SPEB-432PA
SA-200	2.000	4	3.250	1.250	.340	.750	538T	T-10	SPEB-332P

Positive Top Inserts

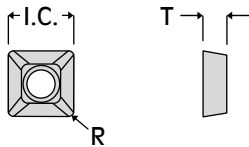

Insert Info.

Insert #	I.C.	T	R	Grades
SDEB-2151P	.250	.093	.015	X33
SPEB-222P	.250	.125	.031	B1M A9M X33
SPEB-2522P	.312	.125	.031	B1M A9M X33 X40
SPEB-332P	.375	.187	.031	B1M A9M X33 X40
SPEB-432PA	.500	.187	.031	B1M A9M X33 X40

Speed and Feed Info.

Material	S.F.M.	.375-.500 Dia. I.P.T.	.625-2.000 Dia. I.P.T.
Mild & Low Carbon Steel Ex. 1018, 1020, 1117, 1141, 12L14	800 - 1200	.002 - .003	.002 - .005
High Carbon & Alloy Steel Ex. 1045, 4140, 4340, 52100, 8620	500 - 800	.002 - .003	.002 - .004
Lower Carbon Tool Steel Ex. P-20, H-13, S-7	400 - 700	.002 - .003	.002 - .004
Tool Steel Ex. A-2, A-6, D-2, M-2	300 - 600	.001 - .003	.002 - .004
Stainless Steel Ex. 304, 316, 420, 15-5PH, 17-4PH	300 - 600	.002 - .003	.002 - .004
Iron Ex. Cast, Ductile, Nodular	600 - 1000	.002 - .003	.002 - .005
Nickel & Titanium Alloy Ex. Inconel, Hastelloy, Ti-6AL-4V	120 - 180	.001 - .002	.001 - .003
Non-Ferrous Metal Ex. Aluminum, Bronze, Brass	1000 - 2500	.002 - .003	.002 - .006

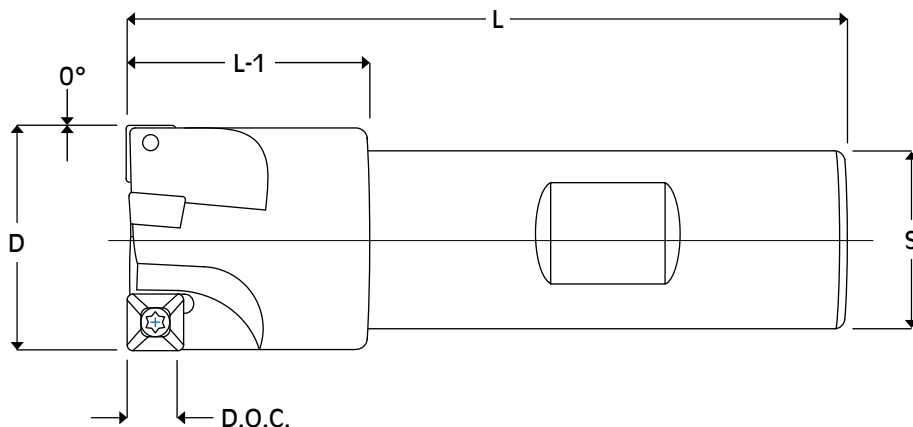

Tool Info.

Tool #	D	Flutes	L	L-1	D.O.C.	S	Screw	Wrench	Insert
SA-750MF	.750	3	3.000	1.000	.215	.750	314T	T-8	SPEB-222P
SA-100MF	1.000	4	3.000	1.000	.215	.750			
SA-125MF	1.250	4	3.250	1.250	.280	.750	314T	T-8	SPEB-2522P
SA-150MF	1.500	5	3.250	1.250	.280	.750			
SA-200MF	2.000	6	3.250	1.250	.280	.750			

Positive Top Inserts

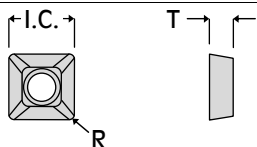

Insert Info.

Insert #	I.C.	T	R	Grades
SPEB-222P	.250	.125	.031	B1M A9M X33
SPEB-2522P	.312	.125	.031	B1M A9M X33 X40

Speed and Feed Info.

Material	S.F.M.	I.P.T.
Mild & Low Carbon Steel Ex. 1018, 1020, 1117, 1141, 12L14	800 - 1200	.002 - .005
High Carbon & Alloy Steel Ex. 1045, 4140, 4340, 52100, 8620	500 - 800	.002 - .004
Lower Carbon Tool Steel Ex. P-20, H-13, S-7	400 - 700	.002 - .004
Tool Steel Ex. A-2, A-6, D-2, M-2	300 - 600	.002 - .004
Stainless Steel Ex. 304, 316, 420, 15-5PH, 17-4PH	300 - 600	.002 - .004
Iron Ex. Cast, Ductile, Nodular	600 - 1000	.002 - .005
Nickel & Titanium Alloy Ex. Inconel, Hastelloy, Ti-6AL-4V	120 - 180	.001 - .003
Non-Ferrous Metal Ex. Aluminum, Bronze, Brass	1000 - 2500	.002 - .006

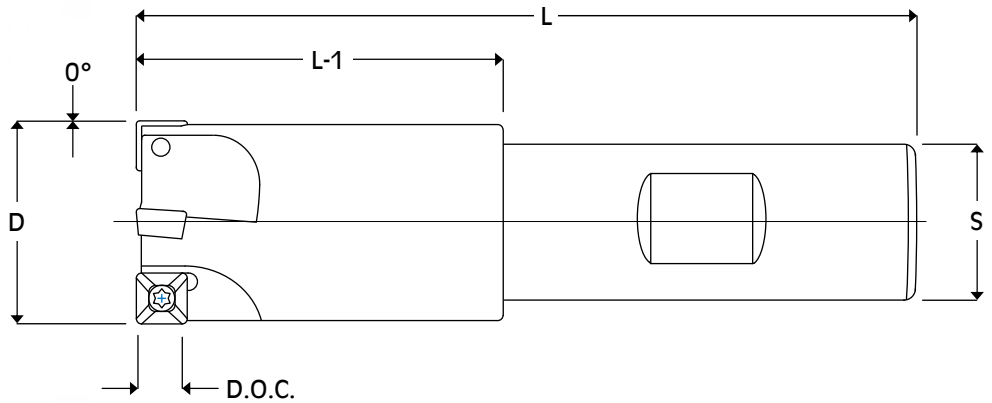

Tool Info.

Tool #	D	Flutes	L	L-1	D.O.C.	S	Screw	Wrench	Insert
SAL-750MF	.750	3	3.500	1.500	.215	.750	314T	T-8	SPEB-222P
SAL-100MF	1.000	4	3.750	1.750	.215	.750			
SAL-125MF	1.250	4	4.000	2.000	.280	.750	314T	T-8	SPEB-2522P
SAL-150MF	1.500	5	4.250	2.000	.280	1.000			
SAL-200MF	2.000	6	4.500	2.250	.280	1.000			

Positive Top Inserts

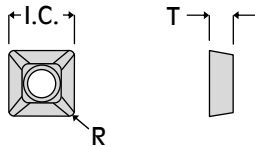

Insert Info.

Insert #	I.C.	T	R	Grades
SPEB-222P	.250	.125	.031	B1M A9M X33
SPEB-2522P	.312	.125	.031	B1M A9M X33 X40

Speed and Feed Info.

Material	S.F.M.	I.P.T.
Mild & Low Carbon Steel Ex. 1018, 1020, 1117, 1141, 12L14	800 - 1200	.002 - .005
High Carbon & Alloy Steel Ex. 1045, 4140, 4340, 52100, 8620	500 - 800	.002 - .004
Lower Carbon Tool Steel Ex. P-20, H-13, S-7	400 - 700	.002 - .004
Tool Steel Ex. A-2, A-6, D-2, M-2	300 - 600	.002 - .004
Stainless Steel Ex. 304, 316, 420, 15-5PH, 17-4PH	300 - 600	.002 - .004
Iron Ex. Cast, Ductile, Nodular	600 - 1000	.002 - .005
Nickel & Titanium Alloy Ex. Inconel, Hastelloy, Ti-6AL-4V	120 - 180	.001 - .003
Non-Ferrous Metal Ex. Aluminum, Bronze, Brass	1000 - 2500	.002 - .006

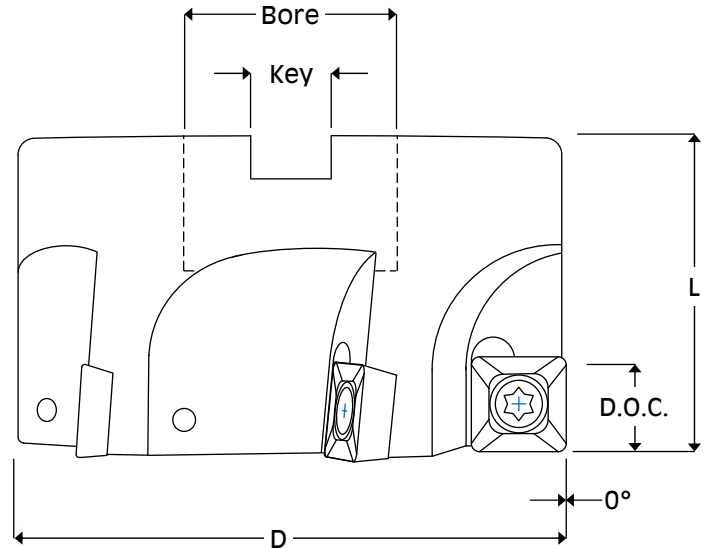
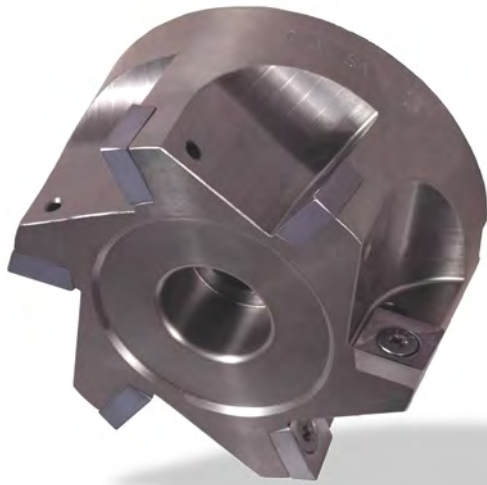

<i>Tool Info.</i>									
Tool #	D	Flutes	L	D.O.C.	Bore	Key	Screw	Wrench	Insert
SA-2000	2.000	4	1.500	.465	.750	.312	638T	T-15	SPEB-432PA
SA-2500	2.500	5	1.625	.465	1.000	.375			
SA-3000	3.000	6	1.625	.465	1.000	.375			

<i>Multi Flute Tool Info.</i>									
Tool #	D	Flutes	L	D.O.C.	Bore	Key	Screw	Wrench	Insert
SA-150MFS	1.500	5	1.250	.280	.500	.250	314T	T-8	SPEB-2522P
SA-200MFS	2.000	6	1.500	.280	.750	.312			

For Larger Diameters, Refer to Universal Mills on Page 133

Positive Top Inserts				
<i>Insert Info.</i>				
Insert #	I.C.	T	R	Grades
SPEB-2522P	.312	.125	.031	B1M A9M X33 X40
SPEB-432PA	.500	.187	.031	B1M A9M X33 X40

<i>Speed and Feed Info.</i>		
Material	S.F.M.	I.P.T.
Mild & Low Carbon Steel Ex. 1018, 1020, 1117, 1141, 12L14	800 - 1200	.002 - .005
High Carbon & Alloy Steel Ex. 1045, 4140, 4340, 52100, 8620	500 - 800	.002 - .004
Lower Carbon Tool Steel Ex. P-20, H-13, S-7	400 - 700	.002 - .004
Tool Steel Ex. A-2, A-6, D-2, M-2	300 - 600	.002 - .004
Stainless Steel Ex. 304, 316, 420, 15-5PH, 17-4PH	300 - 600	.002 - .004
Iron Ex. Cast, Ductile, Nodular	600 - 1000	.002 - .005
Nickel & Titanium Alloy Ex. Inconel, Hastelloy, TI-6AL-4V	120 - 180	.001 - .003
Non-Ferrous Metal Ex. Aluminum, Bronze, Brass	1000 - 2500	.002 - .006

Eight Square Positive Mills

Square Shoulder Mills With Positive Top & Positive Axial Rake

Available Modifications

- Reduce Shank Diameters
- Coolant Thru

2 - 3 Day Delivery



Applications



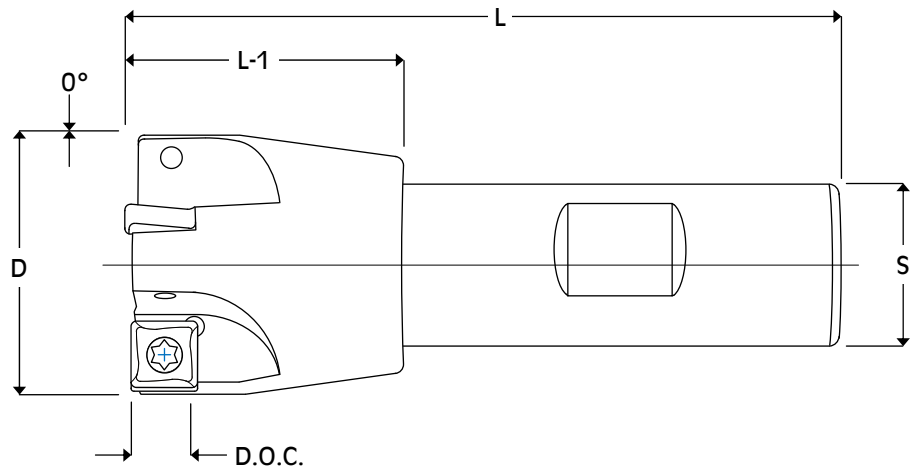

<i>Tool Info.</i>									
Tool #	D	Flutes	L	L-1	D.O.C.	S	Screw	Wrench	Insert
ESP-750-2	.750	2	3.000	1.000	.280	.750	314T	T-8	SNPG-2522
ESP-1000-2	1.000	3	3.000	1.000	.280	.750			
ESP-1250-2	1.250	4	3.250	1.250	.280	.750			
ESP-1500-2	1.500	5	3.250	1.250	.280	.750			
ESP-2000-2	2.000	6	3.250	1.250	.280	.750			
ESP-1500-3	1.500	3	4.000	1.750	.405	1.000	538T	T-10	SNPG-3532
ESP-2000-3	2.000	4	4.000	1.750	.405	1.000			

<i>Insert Info.</i>				
Insert #	I.C.	T	R	Grade
SNPG-2522	.312	.125	.031	X33
SNPG-3532	.437	.187	.031	X33

<i>Speed and Feed Info.</i>		
Material	S.F.M.	I.P.T.
Mild & Low Carbon Steel Ex. 1018, 1020, 1117, 1141, 12L14	800 - 1200	.003 - .006
High Carbon & Alloy Steel Ex. 1045, 4140, 4340, 52100, 8620	500 - 800	.003 - .005
Lower Carbon Tool Steel Ex. P-20, H-13, S-7	400 - 700	.003 - .005
Tool Steel Ex. A-2, A-6, D-2, M-2	300 - 600	.003 - .005
Stainless Steel Ex. 304, 316, 420, 15-5PH, 17-4PH	300 - 600	.003 - .005
Iron Ex. Cast, Ductile, Nodular	600 - 1000	.003 - .006
Nickel & Titanium Alloy Ex. Inconel, Hastelloy, Ti-6AL-4V	120 - 180	.001 - .003
Non-Ferrous Metal Ex. Aluminum, Bronze, Brass	1000 - 2500	.003 - .007

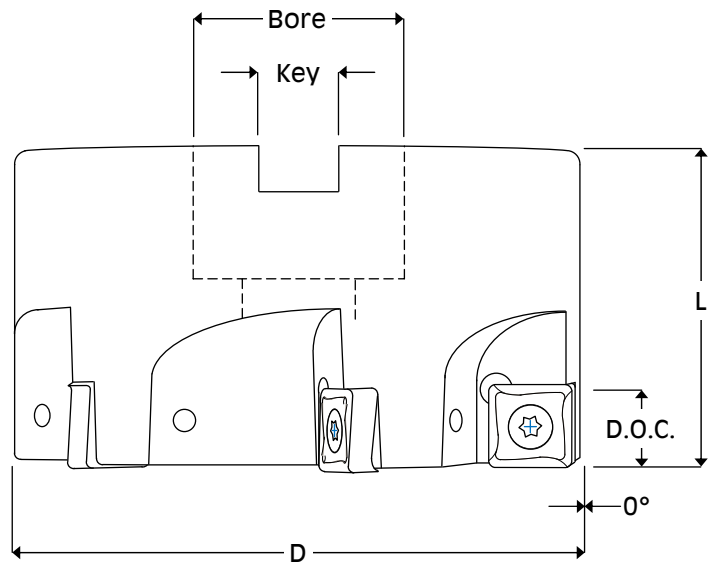

Tool Info.

Tool #	D	Flutes	L	D.O.C.	Bore	Key	Screw	Wrench	Insert
ESPS-2000-3	2.000	4	1.500	.405	.750	.312	538T	T-10	SNPG-3532
ESPS-2500-3	2.500	6	1.625	.405	1.000	.375			
ESPS-3000-3	3.000	6	1.625	.405	1.000	.375			

For Larger Diameters, Refer to Universal Mills on Page 133

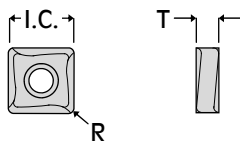

Insert Info.

Insert #	I.C.	T	R	Grade
SNPG-3532	.437	.187	.031	X33

Speed and Feed Info.

Material	S.F.M.	I.P.T.
Mild & Low Carbon Steel Ex. 1018, 1020, 1117, 1141, 12L14	800 - 1200	.003 - .006
High Carbon & Alloy Steel Ex. 1045, 4140, 4340, 52100, 8620	500 - 800	.003 - .005
Lower Carbon Tool Steel Ex. P-20, H-13, S-7	400 - 700	.003 - .005
Tool Steel Ex. A-2, A-6, D-2, M-2	300 - 600	.003 - .005
Stainless Steel Ex. 304, 316, 420, 15-5PH, 17-4PH	300 - 600	.003 - .005
Iron Ex. Cast, Ductile, Nodular	600 - 1000	.003 - .006
Nickel & Titanium Alloy Ex. Inconel, Hastelloy, Ti-6AL-4V	120 - 180	.001 - .003
Non-Ferrous Metal Ex. Aluminum, Bronze, Brass	1000 - 2500	.003 - .007

Stockbusters

Long Edge Roughing Mills

Offset Inserts to
Reduce Tool Pressure

Available in Shank or
CAT-50 Taper

Applications



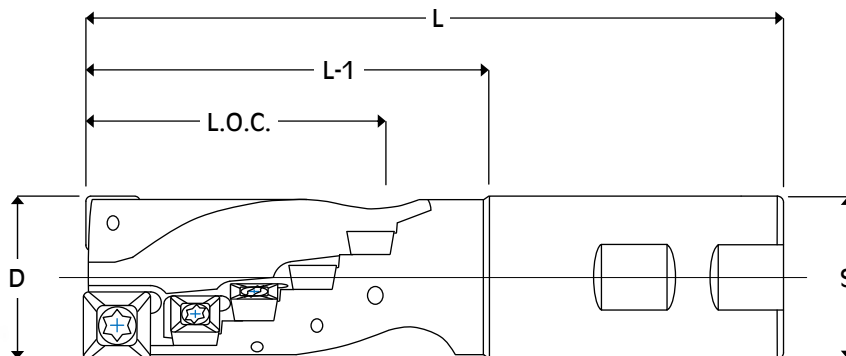

Tool Info.

Tool #	D	Inserts	Flutes	L	L-1	L.O.C.	S	Screw	Wrench	Inserts
SB-100	1.000	10	2-1 Effective	4.125	1.875	1.500	1.000	438T 314T	T-10 T-8	(1) SPEB-322P (9) SPEB-222P
SB-125	1.250	11	2-1 Effective	5.250	3.000	2.500	1.250	638T 538T	T-15 T-10	(1) SPEB-432PA (10) SPEB-332P
SB-150	1.500	17	3-1.5 Effective	5.250	3.000	2.500	1.250	638T 538T	T-15 T-10	(1) SPEB-432PA (16) SPEB-332P
SB-202	2.000	22	4-2 Effective	5.690	3.000	2.500	1.250	638T 538T	T-15 T-10	(2) SPEB-432PA (20) SPEB-332P

Positive Top Inserts

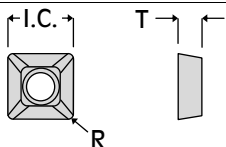

Insert Info.

Insert #	I.C.	T	R	Grades
SPEB-222P	.250	.125	.031	B1M A9M X33
SPEB-322P	.375	.125	.031	B1M A9M X33 X40
SPEB-332P	.375	.187	.031	B1M A9M X33 X40
SPEB-432PA	.500	.187	.031	B1M A9M X33 X40

Speed and Feed Info.

Material	S.F.M.	I.P.T.
Mild & Low Carbon Steel Ex. 1018, 1020, 1117, 1141, 12L14	400 - 800	.002 - .006
High Carbon & Alloy Steel Ex. 1045, 4140, 4340, 52100, 8620	300 - 500	.002 - .005
Lower Carbon Tool Steel Ex. P-20, H-13, S-7	300 - 500	.002 - .005
Tool Steel Ex. A-2, A-6, D-2, M-2	300 - 500	.002 - .004
Stainless Steel Ex. 304, 316, 420, 15-5PH, 17-4PH	300 - 500	.002 - .004
Iron Ex. Cast, Ductile, Nodular	400 - 800	.003 - .007
Nickel & Titanium Alloy Ex. Inconel, Hastelloy, Ti-6AL-4V	100 - 200	.001 - .003
Non-Ferrous Metal Ex. Aluminum, Bronze, Brass	800 - 1200	.003 - .007

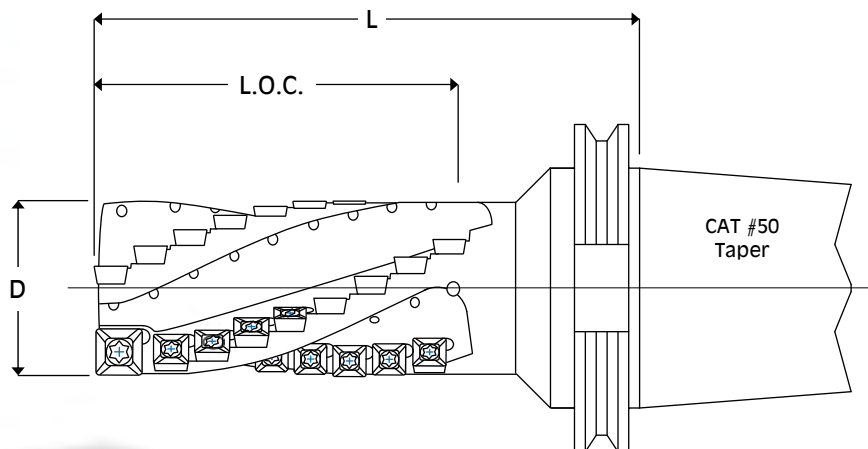

Tool Info.

Tool #	D	Flutes	Inserts	L	L.O.C.	Screw	Wrench	Inserts
V50-204SB	2.000	4-2 Effective	36	6.000	4.000	638T 538T	T-15 T-10	(2) SPEB-432PA (34) SPEB-332P

Positive Top Inserts

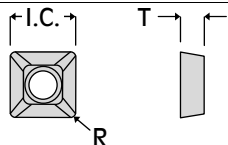

Insert Info.

Insert #	I.C.	T	R	Grades
SPEB-332P	.375	.187	.031	B1M A9M X33 X40
SPEB-432PA	.500	.187	.031	B1M A9M X33 X40

Speed and Feed Info.

Material	S.F.M.	I.P.T.
Mild & Low Carbon Steel Ex. 1018, 1020, 1117, 1141, 12L14	400 - 800	.002 - .006
High Carbon & Alloy Steel Ex. 1045, 4140, 4340, 52100, 8620	300 - 500	.002 - .005
Lower Carbon Tool Steel Ex. P-20, H-13, S-7	300 - 500	.002 - .005
Tool Steel Ex. A-2, A-6, D-2, M-2	300 - 500	.002 - .004
Stainless Steel Ex. 304, 316, 420, 15-5PH, 17-4PH	300 - 500	.002 - .004
Iron Ex. Cast, Ductile, Nodular	400 - 800	.003 - .007
Nickel & Titanium Alloy Ex. Inconel, Hastelloy, Ti-6AL-4V	100 - 200	.001 - .003
Non-Ferrous Metal Ex. Aluminum, Bronze, Brass	800 - 1200	.003 - .007

Universal Mills

Multi-Geometry Cartridge Style Face Mills

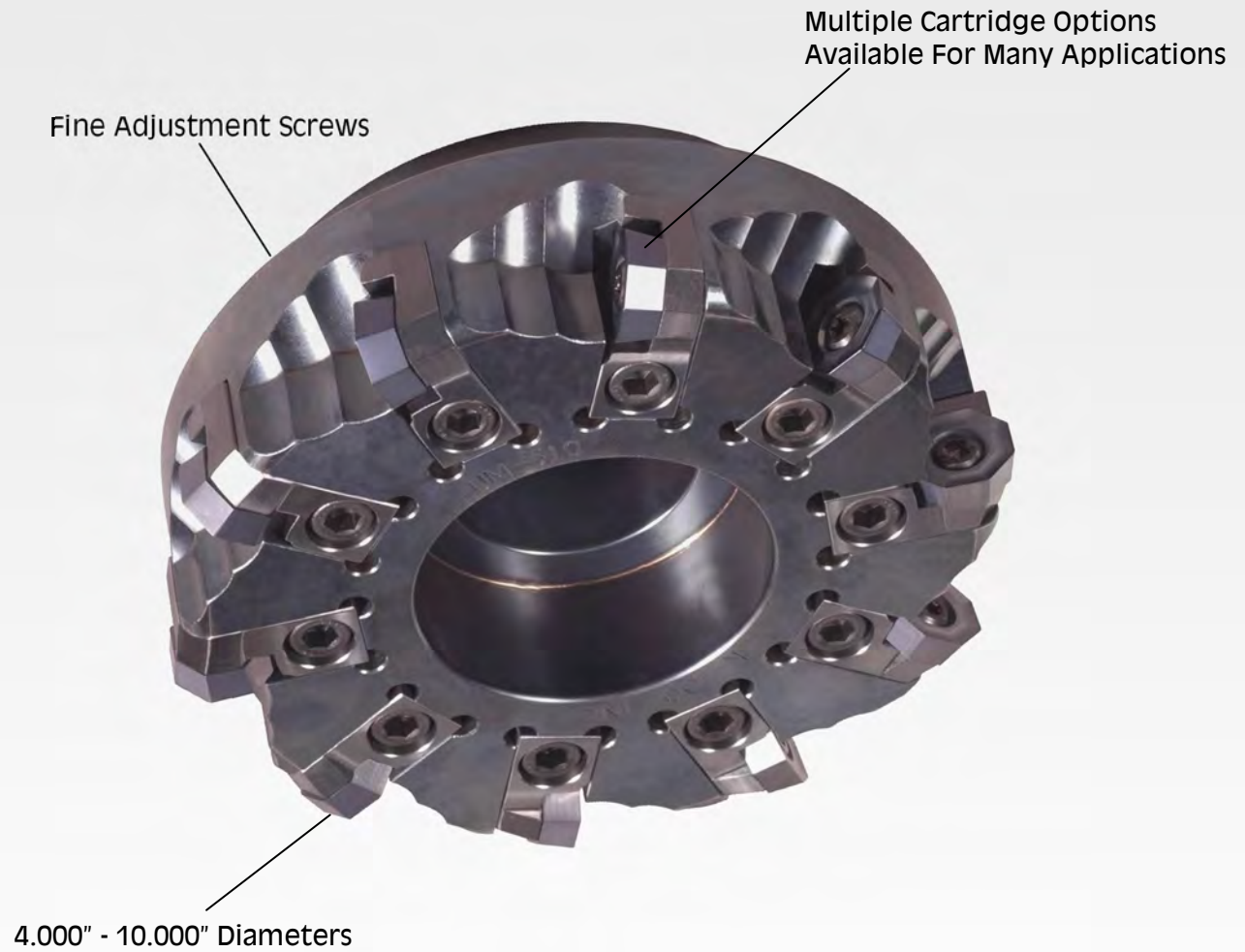

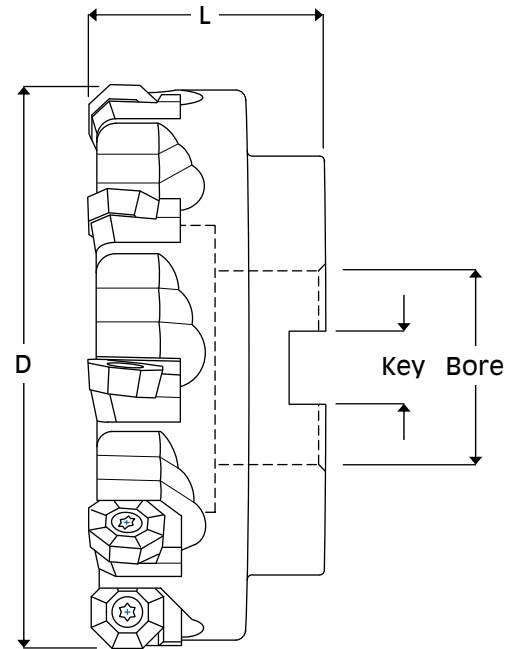

Tool Info.

Tool #	D	Flutes	L	Bore	Key	Cartridge Screw	Allen Wrench	Adjustment Screw
UM-408	4.000	8	1.875	1.250	.500	142878	3/16"	1/4-28 x 3/8"
UM-510	5.000	10	2.000	1.500	.625			
UM-612	6.000	12	2.000	1.500	.625			
UM-816	8.000	16	2.250	2.500 With	1.000			
UM-1020	10.000	20	2.250	4 Bolt Hole Pattern	1.000			

Speed and Feed Info.

Material	S.F.M.	I.P.T.
Mild & Low Carbon Steel Ex. 1018, 1020, 1117, 1141, 12L14	800 - 1200	.002 - .006
High Carbon & Alloy Steel Ex. 1045, 4140, 4340, 52100, 8620	500 - 800	.002 - .005
Lower Carbon Tool Steel Ex. P-20, H-13, S-7	400 - 700	.002 - .005
Tool Steel Ex. A-2, A-6, D-2, M-2	300 - 600	.002 - .004
Stainless Steel Ex. 304, 316, 420, 15-5PH, 17-4PH	300 - 600	.002 - .004
Iron Ex. Cast, Ductile, Nodular	600 - 1000	.003 - .007
Nickel & Titanium Alloy Ex. Inconel, Hastelloy, Ti-6AL-4V	120 - 180	.001 - .003
Non-Ferrous Metal Ex. Aluminum, Bronze, Brass	1000 - 2500	.003 - .007

Universal Mill Cartridges

NOTE:
SERA Cartridge A & B
must alternate every other pocket.

OCTA Cartridge		OCTA Wiper Cartridge		SERA Cartridge A & B	
Insert - OPEB-535 / RPEB-535 See Page 11 For More Info.		OPEB-535 See Page 11 For More Info.		Insert - SNMC-444B / SNGC-444H See Page 14 For More Info.	
Insert Screw	838T	Insert Screw	838T	Insert Screw	838T
Wrench	T-20	Wrench	T-20	Wrench	T-20

Super Alloy Cartridge		DOC Cartridge		Radius Cartridge	
Insert - SNEB-432PA See Page 13 For More Info.		Insert - ONPG-4532 See Page 11 For More Info.		Insert - MGH-530 SERIES See Page 11 For More Info.	
Insert Screw	638T	Insert Screw	838T	Insert Screw	560T
Wrench	T-15	Wrench	T-20	Wrench	T-10

BC 3 - Button Cartridge		BC 4 - Button Cartridge		30° Cartridge	
Insert - RCEB-325 or RCEB-325G See Page 12 For More Info.		Insert - RCEB-435 or RCEB-435G See Page 12 For More Info.		Insert - SPEB-43-30PA / SPEB-43-30F See Pages 14 & 15 For More Info.	
Insert Screw	538T	Insert Screw	838T	Insert Screw	638T
Wrench	T-10	Wrench	T-20	Wrench	T-15

ESP Cartridge		KELI Cartridge	
Insert - SNPG-3532 See Page 14 For More Info.		LPMT-52-532 / 533 / 534 See Page 10 For More Info.	
Insert Screw	538T	Insert Screw	560T
Wrench	T-10	Wrench	T-10

T-Slot / Key Cutters

Available Modifications

- Reduce Shank Diameters
- Coolant Thru

2 - 3 Day Delivery

Available in Several Widths

Offset Inserts for Reduced Cutting Pressure



Applications

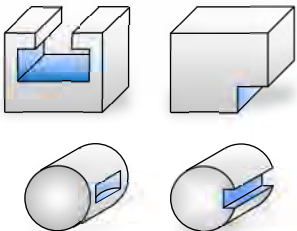

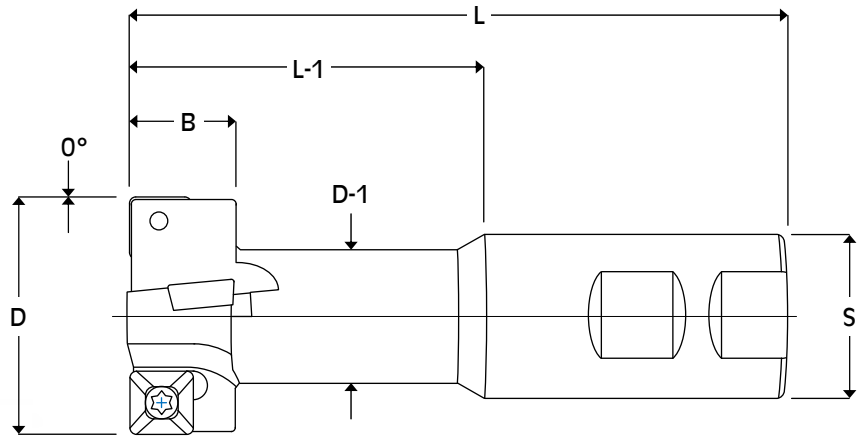

Tool Info.

Tool #	D	D-1	B	Inserts	Eff. Flutes	L	L-1	S	Screw	Wrench	Insert
TS-968	.968	.531	.390	2	1	3.531	1.531	.750	314T	T-8	SPEB-222P
TS-1250	1.250	.656	.484	4	2	4.125	1.875	1.000	314T	T-8	SPEB-2522P
TS-1468	1.468	.781	.625	4	2	4.562	2.312	1.000	438T	T-10	SPEB-322P
TS-1843	1.843	1.031	.828	4	2	4.937	2.687	1.250	638T	T-15	SPEB-432PA

Positive Top Inserts

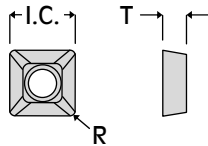

Insert Info.

Insert #	I.C.	T	R	Grades
SPEB-222P	.250	.125	.031	B1M A9M X33
SPEB-2522P	.312	.125	.031	B1M A9M X33 X40
SPEB-322P	.375	.125	.031	B1M A9M X33 X40
SPEB-432PA	.500	.187	.031	B1M A9M X33 X40

Speed and Feed Info.

Material	S.F.M.	I.P.T.
Mild & Low Carbon Steel Ex. 1018, 1020, 1117, 1141, 12L14	800 - 1200	.002 - .005
High Carbon & Alloy Steel Ex. 1045, 4140, 4340, 52100, 8620	500 - 800	.002 - .004
Lower Carbon Tool Steel Ex. P-20, H-13, S-7	400 - 700	.002 - .004
Tool Steel Ex. A-2, A-6, D-2, M-2	300 - 600	.002 - .004
Stainless Steel Ex. 304, 316, 420, 15-5PH, 17-4PH	300 - 600	.002 - .004
Iron Ex. Cast, Ductile, Nodular	600 - 1000	.002 - .005
Nickel & Titanium Alloy Ex. Inconel, Hastelloy, Ti-6AL-4V	120 - 180	.001 - .003
Non-Ferrous Metal Ex. Aluminum, Bronze, Brass	1000 - 2500	.002 - .006

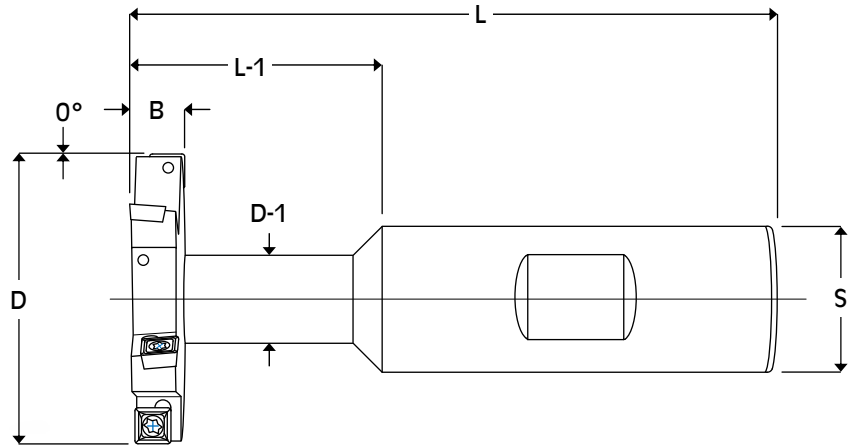

Tool Info.

Tool #	D	D-1	B	Flutes	L	L-1	S	Screw	Wrench	Insert
TSK-1225	1.250	.385	.250	6 Flutes / 3 Effective	3.250	1.250	.750	164T	T-6	SPEB-1511CB
TSK-1525	1.500	.450	.250	6 Flutes / 3 Effective	3.250	1.250	.750			
TSK-2025	2.000	.750	.250	8 Flutes / 4 Effective	4.000	2.000	.750			
TSK-3025	3.000	1.000	.250	8 Flutes / 4 Effective	4.500	2.250	1.000			

Chipbreaker
Insert

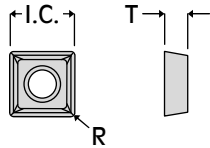

Insert Info.

Insert #	I.C.	T	R	Grades
SPEB-1511CB	.187	.082	.015	X33 X40

Speed and Feed Info.

Material	S.F.M.	I.P.T.
Mild & Low Carbon Steel Ex. 1018, 1020, 1117, 1141, 12L14	800 - 1200	.002 - .003
High Carbon & Alloy Steel Ex. 1045, 4140, 4340, 52100, 8620	500 - 800	.002 - .003
Lower Carbon Tool Steel Ex. P-20, H-13, S-7	400 - 700	.002 - .003
Tool Steel Ex. A-2, A-6, D-2, M-2	300 - 600	.002 - .003
Stainless Steel Ex. 304, 316, 420, 15-5PH, 17-4PH	300 - 600	.002 - .004
Iron Ex. Cast, Ductile, Nodular	600 - 1000	.002 - .003
Nickel & Titanium Alloy Ex. Inconel, Hastelloy, Ti-6AL-4V	120 - 180	.001 - .002
Non-Ferrous Metal Ex. Aluminum, Bronze, Brass	1000 - 2500	.002 - .004

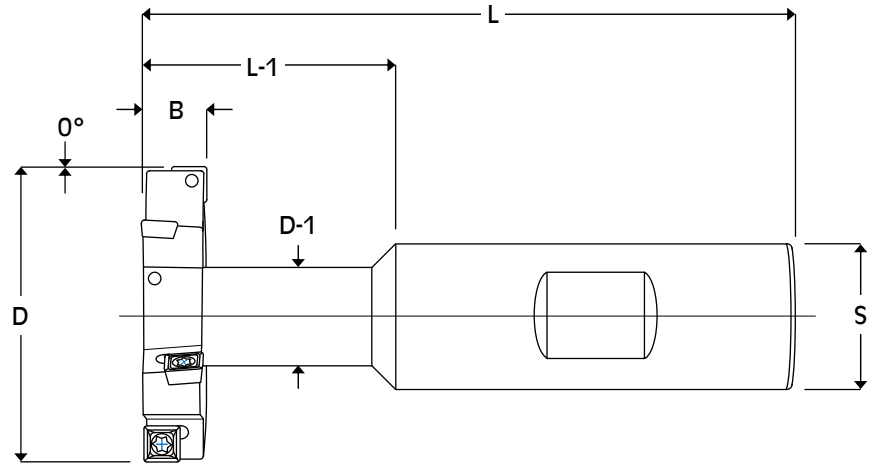

Tool Info.

Tool #	D	D-1	B	Flutes	L	L-1	S	Screw	Wrench	Insert
TSK-1231	1.250	.450	.312	6 Flutes / 3 Effective	3.250	1.250	.750	164T	T-6	SPEB-1511CB
TSK-1531	1.500	.500	.312	6 Flutes / 3 Effective	3.250	1.250	.750			
TSK-2031	2.000	.750	.312	8 Flutes / 4 Effective	4.000	2.000	.750			
TSK-3031	3.000	1.000	.312	8 Flutes / 4 Effective	4.500	2.250	1.000			

Chipbreaker Insert

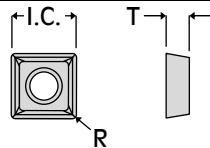

Insert Info.

Insert #	I.C.	T	R	Grades
SPEB-1511CB	.187	.082	.015	X33 X40

Speed and Feed Info.

Material	S.F.M.	I.P.T.
Mild & Low Carbon Steel Ex. 1018, 1020, 1117, 1141, 12L14	800 - 1200	.002 - .003
High Carbon & Alloy Steel Ex. 1045, 4140, 4340, 52100, 8620	500 - 800	.002 - .003
Lower Carbon Tool Steel Ex. P-20, H-13, S-7	400 - 700	.002 - .003
Tool Steel Ex. A-2, A-6, D-2, M-2	300 - 600	.002 - .003
Stainless Steel Ex. 304, 316, 420, 15-5PH, 17-4PH	300 - 600	.002 - .004
Iron Ex. Cast, Ductile, Nodular	600 - 1000	.002 - .003
Nickel & Titanium Alloy Ex. Inconel, Hastelloy, Ti-6AL-4V	120 - 180	.001 - .002
Non-Ferrous Metal Ex. Aluminum, Bronze, Brass	1000 - 2500	.002 - .004

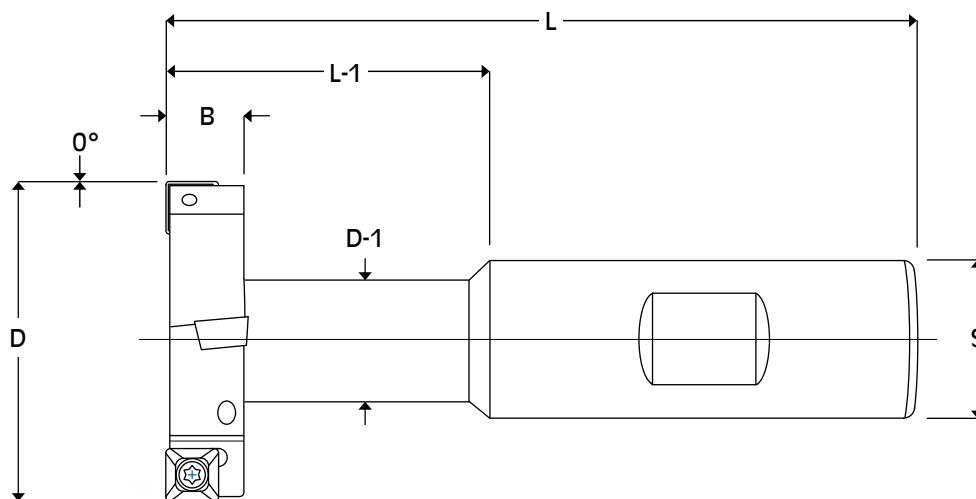

Tool Info.

Tool #	D	D-1	B	Flutes	L	L-1	S	Screw	Wrench	Insert
TSK-1237	1.250	.510	.375	4 Flutes / 2 Effective	3.500	1.500	.750	314T	T-8	SPEB-221P
TSK-1537	1.500	.575	.375	4 Flutes / 2 Effective	3.500	1.500	.750			
TSK-2037	2.000	.750	.375	6 Flutes / 3 Effective	4.000	2.000	.750			
TSK-3037	3.000	1.000	.375	6 Flutes / 3 Effective	4.500	2.250	1.000			

Speed and Feed Info.

Material	S.F.M.	I.P.T.
Mild & Low Carbon Steel Ex. 1018, 1020, 1117, 1141, 12L14	800 - 1200	.002 - .006
High Carbon & Alloy Steel Ex. 1045, 4140, 4340, 52100, 8620	500 - 800	.002 - .005
Lower Carbon Tool Steel Ex. P-20, H-13, S-7	400 - 700	.002 - .005
Tool Steel Ex. A-2, A-6, D-2, M-2	300 - 600	.002 - .004
Stainless Steel Ex. 304, 316, 420, 15-5PH, 17-4PH	300 - 600	.002 - .004
Iron Ex. Cast, Ductile, Nodular	600 - 1000	.003 - .007
Nickel & Titanium Alloy Ex. Inconel, Hastelloy, Ti-6AL-4V	120 - 180	.001 - .003
Non-Ferrous Metal Ex. Aluminum, Bronze, Brass	1000 - 2500	.003 - .008

Positive Top Insert

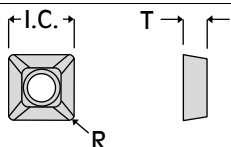

Insert Info.

Insert #	I.C.	T	R	Grade
SPEB-221P	.250	.125	.015	X33

Radius Slotting Mills

Available Modification
-Coolant Thru

2 - 3 Day Delivery

Available in .250 - .375 - .500 W.O.C.

2 Insert Styles Available

Positive Top Inserts



Applications

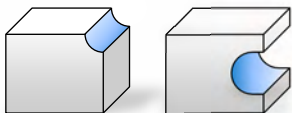

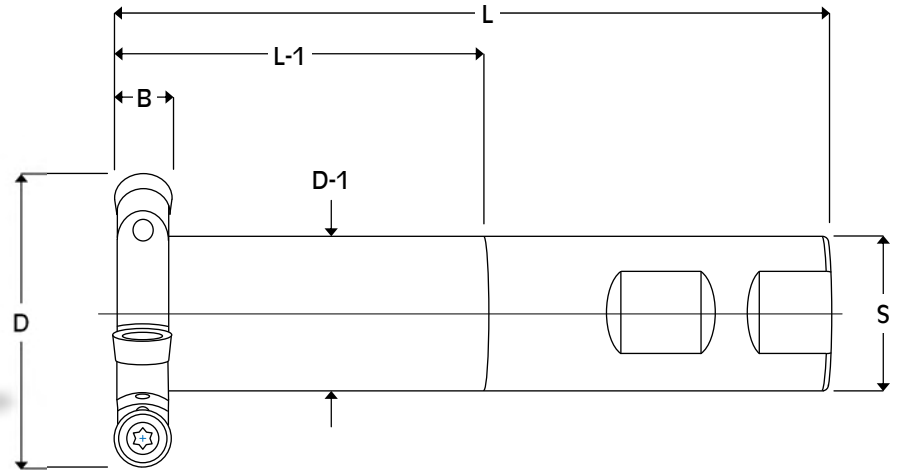

Tool Info.

Tool #	D	D-1	B	Flutes	L	L-1	S	Molded Insert	Ground Insert
TSR-1252	1.250	.625	.250	4	4.125	1.875	1.000	RCEB-22	RCEB-22G
TSR-1253	1.250	.625	.375	3	4.125	1.875	1.000	RCEB-325	RCEB-325G
TSR-1502	1.500	.625	.250	5	4.125	1.875	1.000	RCEB-22	RCEB-22G
TSR-1503	1.500	.625	.375	4	4.125	1.875	1.000	RCEB-325	RCEB-325G
TSR-1504	1.500	.625	.500	3	4.125	1.875	1.000	RCEB-435	RCEB-435G
TSR-2002	2.000	1.000	.250	6	4.625	2.375	1.000	RCEB-22	RCEB-22G
TSR-2003	2.000	1.000	.375	5	4.625	2.375	1.000	RCEB-325	RCEB-325G
TSR-2004	2.000	1.000	.500	4	4.625	2.375	1.000	RCEB-435	RCEB-435G
TSR-2502	2.500	1.000	.250	6	4.625	2.375	1.000	RCEB-22	RCEB-22G
TSR-3002	3.000	1.000	.250	8	4.625	2.375	1.000	RCEB-22	RCEB-22G
TSR-3003	3.000	1.000	.375	6	4.625	2.375	1.000	RCEB-325	RCEB-325G
TSR-3004	3.000	1.000	.500	5	4.625	2.375	1.000	RCEB-435	RCEB-435G

Positive Top Inserts

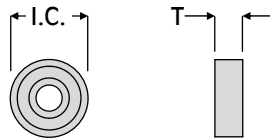

Insert Info.

Insert #	I.C.	T	Screw	Wrench	Grades
RCEB-22	.250	.125	314T	T-8	A10M X33
RCEB-22G	.250	.125	314T	T-8	B1M X33
RCEB-325	.375	.156	538T	T-10	A10M X33
RCEB-325G	.375	.156	538T	T-10	B1M X33
RCEB-435	.500	.220	838T	T-20	A10M X33
RCEB-435G	.500	.220	838T	T-20	B1M X33

Speed and Feed Info.

Material	S.F.M.	I.P.T.
Mild & Low Carbon Steel Ex. 1018, 1020, 1117, 1141, 12L14	800 - 1200	.002 - .003
High Carbon & Alloy Steel Ex. 1045, 4140, 4340, 52100, 8620	500 - 800	.002 - .003
Lower Carbon Tool Steel Ex. P-20, H-13, S-7	400 - 700	.002 - .003
Tool Steel Ex. A-2, A-6, D-2, M-2	300 - 600	.002 - .003
Stainless Steel Ex. 304, 316, 420, 15-5PH, 17-4PH	300 - 600	.002 - .003
Iron Ex. Cast, Ductile, Nodular	600 - 1000	.002 - .003
Nickel & Titanium Alloy Ex. Inconel, Hastelloy, Ti-6AL-4V	120 - 180	.001 - .002
Non-Ferrous Metal Ex. Aluminum, Bronze, Brass	1000 - 2500	.002 - .004

Slotting / Half Side Mills

Adjustable High Shear Cartridge Style Cutters

Allow 1 - 2 working days for setting to specified width

Adjustable W.O.C.

Available in Arbor Mount
or Shell Mount



Can be set as
-Left Hand (L.H.)
-Right Hand (R.H.)
-Staggered / Full Slot (W.O.C. required)

Applications

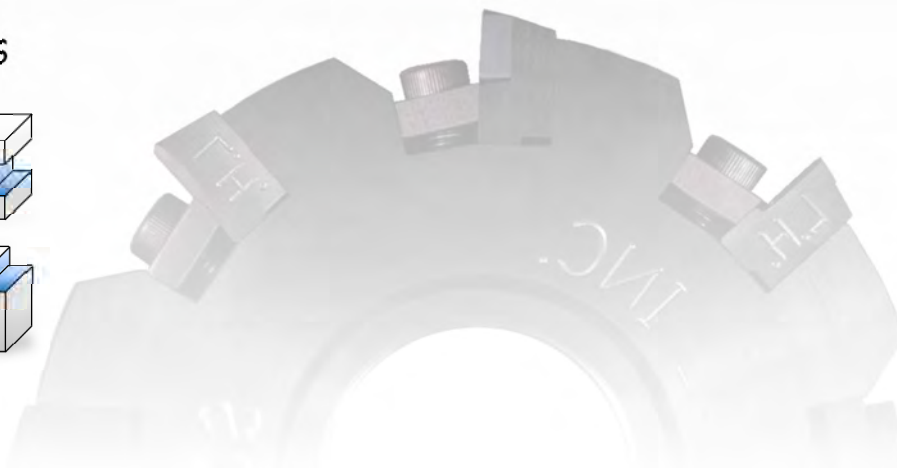
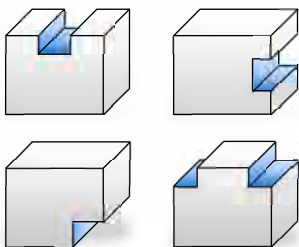

Arbor Mount

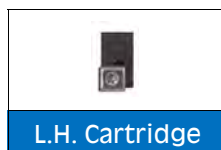
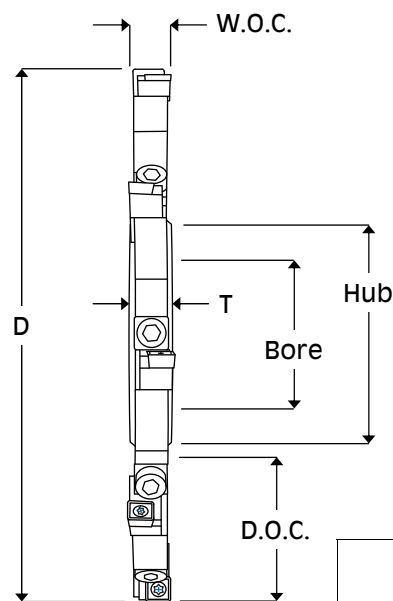

Series #00

Cutters can be used as: Half Side Mill (RH or LH)
Full Slot Mill (W.O.C. Required)

Tool Info.

Tool #	D	Flutes	W.O.C.	D.O.C.	Bore	Key	Hub	T
SC-4000	4.000	10	.250 - .340	1.090	1.250	.312	1.630	.340
SC-5000	5.000	12		1.590	1.250	.312	1.630	.340
SC-6000	6.000	14		1.900	1.500	.375	2.000	.340

Notes:

- Tool must be run as 1/2 the number of flutes effective when set for a full slot.
- Initial W.O.C. to be set with dial indicator (K-Tool Inc. will set width at no charge before shipping).

Tool #	Cartridge	Wedge	Wedge Screw	Insert
SC-4000	#1511C-RH/LH	#1	#6	SPEB-1511CB
SC-5000				
SC-6000				

Speed and Feed Info.

Material	S.F.M.	I.P.T.
Mild & Low Carbon Steel Ex. 1018, 1020, 1117, 1141, 12L14	800 - 1200	.002 - .003
High Carbon & Alloy Steel Ex. 1045, 4140, 4340, 52100, 8620	500 - 800	.002 - .003
Lower Carbon Tool Steel Ex. P-20, H-13, S-7	400 - 700	.002 - .003
Tool Steel Ex. A-2, A-6, D-2, M-2	300 - 600	.002 - .003
Stainless Steel Ex. 304, 316, 420, 15-5PH, 17-4PH	300 - 600	.002 - .003
Iron Ex. Cast, Ductile, Nodular	600 - 1000	.002 - .003
Nickel & Titanium Alloy Ex. Inconel, Hastelloy, Ti-6AL-4V	120 - 180	.001 - .002
Non-Ferrous Metal Ex. Aluminum, Bronze, Brass	1000 - 2500	.002 - .004

Chipbreaker Insert

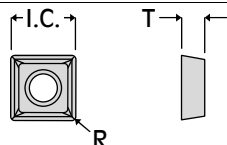

Insert Info.

Insert #	I.C.	T	R	Screw	Wrench	Grades
SPEB-1511CB	.187	.082	.015	164T	T-6	X33 X40

Shell Mount

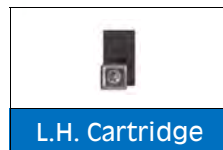
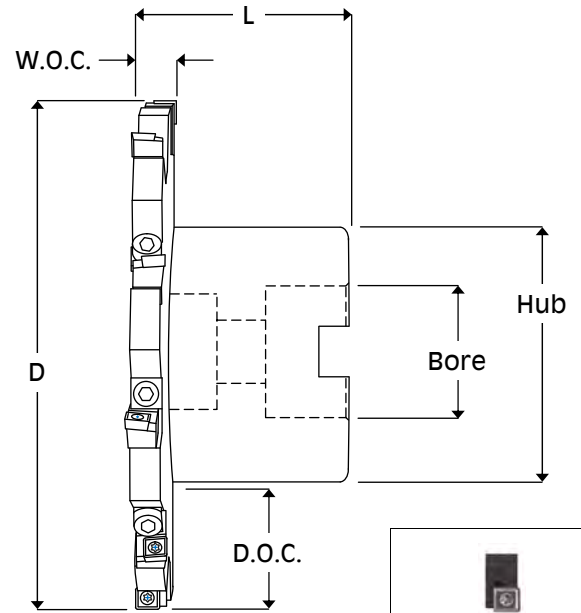

Series #00

Cutters can be used as: Half Side Mill (RH or LH)
Full Slot Mill (W.O.C. Required)

Tool Info.

Tool #	D	Flutes	W.O.C.	D.O.C.	Bore	Key	Hub	L
SCSM-4000	4.000	10	.250 - .340	.875	1.000	.375	2.000	1.625
SCSM-5000	5.000	12		1.062	1.250	.500	2.625	1.750
SCSM-6000	6.000	14		1.562	1.250	.500	2.625	1.750

Notes:

- Tool must be run as 1/2 the number of flutes effective when set for a full slot.
- Initial W.O.C. to be set with dial indicator (K-Tool Inc. will set width at no charge before shipping).

Tool #	Cartridge	Wedge	Wedge Screw	Insert
SCSM-4000	#1511C-RH/LH	#1	#6	SPEB-1511CB
SCSM-5000				
SCSM-6000				

Speed and Feed Info.

Material	S.F.M.	I.P.T.
Mild & Low Carbon Steel Ex. 1018, 1020, 1117, 1141, 12L14	800 - 1200	.002 - .003
High Carbon & Alloy Steel Ex. 1045, 4140, 4340, 52100, 8620	500 - 800	.002 - .003
Lower Carbon Tool Steel Ex. P-20, H-13, S-7	400 - 700	.002 - .003
Tool Steel Ex. A-2, A-6, D-2, M-2	300 - 600	.002 - .003
Stainless Steel Ex. 304, 316, 420, 15-5PH, 17-4PH	300 - 600	.002 - .003
Iron Ex. Cast, Ductile, Nodular	600 - 1000	.002 - .003
Nickel & Titanium Alloy Ex. Inconel, Hastelloy, Ti-6AL-4V	120 - 180	.001 - .002
Non-Ferrous Metal Ex. Aluminum, Bronze, Brass	1000 - 2500	.002 - .004

Chipbreaker Insert

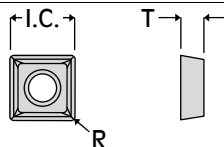

Insert Info.

Insert #	I.C.	T	R	Screw	Wrench	Grades
SPEB-1511CB	.187	.082	.015	164T	T-6	X33 X40

Arbor Mount

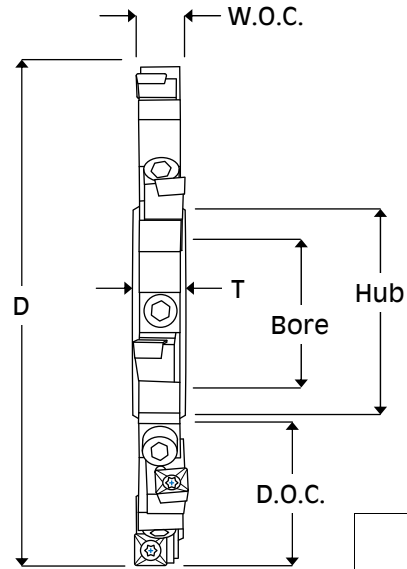

Series #0

Cutters can be used as: Half Side Mill (RH or LH)
Full Slot Mill (W.O.C. Required)

Tool Info.

Tool #	D	Flutes	W.O.C.	D.O.C.	Bore	Key	Hub	T
SC-400	4.000	10	.340 - .430	1.090	1.250	.312	1.630	.422
SC-500	5.000	12		1.590	1.250	.312	1.630	.422
SC-600	6.000	14		1.900	1.500	.375	2.000	.422

Notes:

- Tool must be run as 1/2 the number of flutes effective when set for a full slot.
- Initial W.O.C. to be set with dial indicator (K-Tool Inc. will set width at no charge before shipping).

Tool #	Cartridge	Wedge	Wedge Screw	Insert
SC-400	#222C-RH/LH	#2	#8	SPEB-222P
SC-500				
SC-600				

Speed and Feed Info.

Material	S.F.M.	I.P.T.
Mild & Low Carbon Steel Ex. 1018, 1020, 1117, 1141, 12L14	800 - 1200	.002 - .006
High Carbon & Alloy Steel Ex. 1045, 4140, 4340, 52100, 8620	500 - 800	.002 - .005
Lower Carbon Tool Steel Ex. P-20, H-13, S-7	400 - 700	.002 - .005
Tool Steel Ex. A-2, A-6, D-2, M-2	300 - 600	.002 - .004
Stainless Steel Ex. 304, 316, 420, 15-5PH, 17-4PH	300 - 600	.002 - .004
Iron Ex. Cast, Ductile, Nodular	600 - 1000	.003 - .007
Nickel & Titanium Alloy Ex. Inconel, Hastelloy, Ti-6AL-4V	120 - 180	.001 - .003
Non-Ferrous Metal Ex. Aluminum, Bronze, Brass	1000 - 2500	.003 - .008

Positive Top Insert

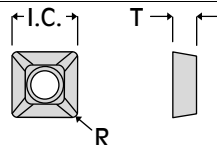

Insert Info.

Insert #	I.C.	T	R	Screw	Wrench	Grades
SPEB-222P	.250	.125	.031	314T	T-8	A9M B1M X33

Shell Mount

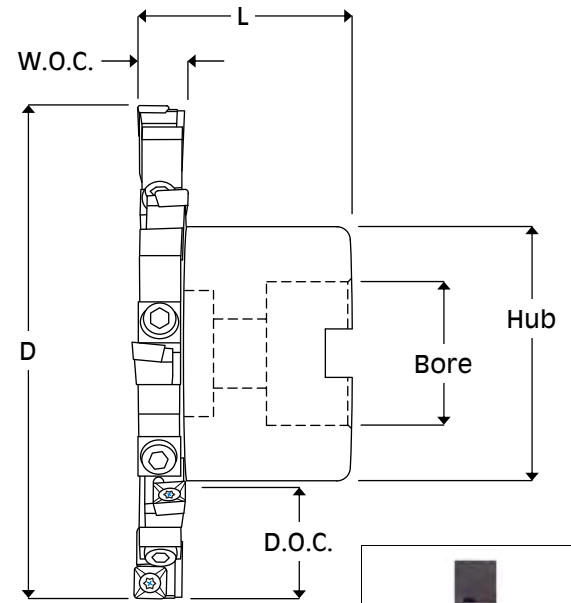

Series #0

Cutters can be used as: Half Side Mill (RH or LH)
Full Slot Mill (W.O.C. Required)

Tool Info.

Tool #	D	Flutes	W.O.C.	D.O.C.	Bore	Key	Hub	L
SCSM-400	4.000	10	.340 - .430	.875	1.000	.375	2.000	1.625
SCSM-500	5.000	12		1.062	1.250	.500	2.625	1.750
SCSM-600	6.000	14		1.562	1.250	.500	2.625	1.750

Notes:

- Tool must be run as 1/2 the number of flutes effective when set for a full slot.
- Initial W.O.C. to be set with dial indicator (K-Tool Inc. will set width at no charge before shipping).

Tool #	Cartridge	Wedge	Wedge Screw	Insert
SCSM-400				
SCSM-500	#222C-RH/LH	#2	#8	SPEB-222P
SCSM-600				

Positive Top Insert

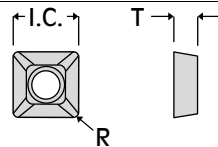

Insert Info.

Insert #	I.C.	T	R	Screw	Wrench	Grades
SPEB-222P	.250	.125	.031	314T	T-8	A9M B1M X33

Speed and Feed Info.

Material	S.F.M.	I.P.T.
Mild & Low Carbon Steel Ex. 1018, 1020, 1117, 1141, 12L14	800 - 1200	.002 - .006
High Carbon & Alloy Steel Ex. 1045, 4140, 4340, 52100, 8620	500 - 800	.002 - .005
Lower Carbon Tool Steel Ex. P-20, H-13, S-7	400 - 700	.002 - .005
Tool Steel Ex. A-2, A-6, D-2, M-2	300 - 600	.002 - .004
Stainless Steel Ex. 304, 316, 420, 15-5PH, 17-4PH	300 - 600	.002 - .004
Iron Ex. Cast, Ductile, Nodular	600 - 1000	.003 - .007
Nickel & Titanium Alloy Ex. Inconel, Hastelloy, Ti-6AL-4V	120 - 180	.001 - .003
Non-Ferrous Metal Ex. Aluminum, Bronze, Brass	1000 - 2500	.003 - .008

Arbor Mount

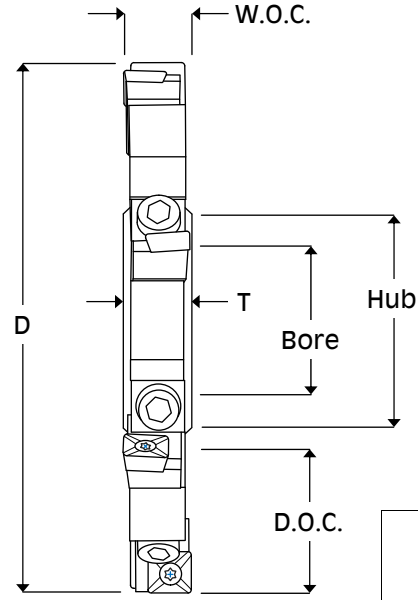

Series #1

Cutters can be used as: Half Side Mill (RH or LH)
Full Slot Mill (W.O.C. Required)

Tool Info.

Tool #	D	Flutes	W.O.C.	D.O.C.	Bore	Key	Hub	T
SC-401	4.000	8	.430 - .530	1.090	1.250	.312	1.630	.500
SC-501	5.000	10		1.590	1.250	.312	1.630	.500
SC-601	6.000	12		1.900	1.500	.375	2.000	.500
SC-801	8.000	16		2.900	1.500	.375	2.000	.500

Notes:

- Tool must be run as 1/2 the number of flutes effective when set for a full slot.
- Initial W.O.C. to be set with dial indicator (K-Tool Inc. will set width at no charge before shipping).

Tool #	Cartridge	Wedge	Wedge Screw	Insert
SC-401	#2522C-RH/LH	#3	#10	SPEB-2522P
SC-501				
SC-601				
SC-801				

45° Cartridge

Cart. #	2522C-45
Insert	SPEB-2522P

Speed and Feed Info.

Material	S.F.M.	I.P.T.
Mild & Low Carbon Steel Ex. 1018, 1020, 1117, 1141, 12L14	800 - 1200	.002 - .006
High Carbon & Alloy Steel Ex. 1045, 4140, 4340, 52100, 8620	500 - 800	.002 - .005
Lower Carbon Tool Steel Ex. P-20, H-13, S-7	400 - 700	.002 - .005
Tool Steel Ex. A-2, A-6, D-2, M-2	300 - 600	.002 - .004
Stainless Steel Ex. 304, 316, 420, 15-5PH, 17-4PH	300 - 600	.002 - .004
Iron Ex. Cast, Ductile, Nodular	600 - 1000	.003 - .007
Nickel & Titanium Alloy Ex. Inconel, Hastelloy, Ti-6AL-4V	120 - 180	.001 - .003
Non-Ferrous Metal Ex. Aluminum, Bronze, Brass	1000 - 2500	.003 - .008

Positive Top Insert

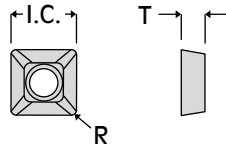

Insert Info.

Insert #	I.C.	T	R	Screw	Wrench	Grades
SPEB-2522P	.312	.125	.031	314T	T-8	A9M BIM X33 X40

Shell Mount

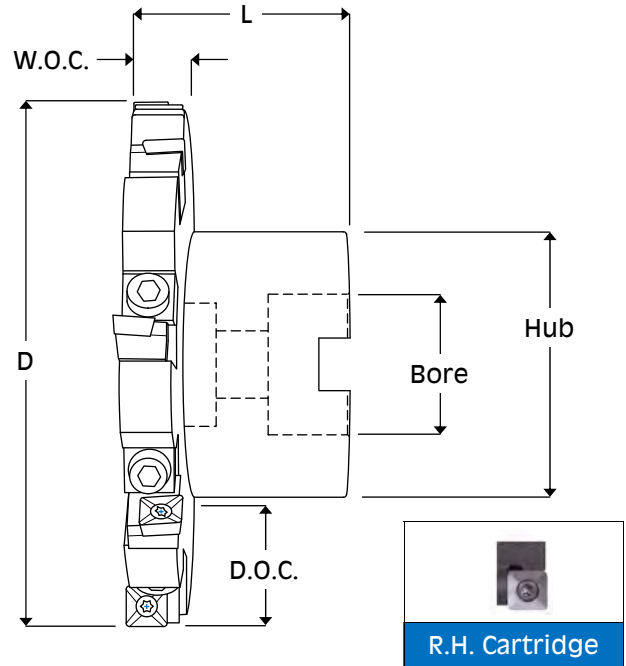

Series #1

Cutters can be used as: Half Side Mill (RH or LH)
Full Slot Mill (W.O.C. Required)

Tool Info.

Tool #	D	Flutes	W.O.C.	D.O.C.	Bore	Key	Hub	L
SCSM-401	4.000	8	.430 - .530	.875	1.000	.375	2.000	1.625
SCSM-501	5.000	10		1.062	1.250	.500	2.625	1.750
SCSM-601	6.000	12		1.000	1.500	.625	3.800	2.250
SCSM-801	8.000	16		1.975	1.500	.625	3.800	2.250

Notes:

- Tool must be run as 1/2 the number of flutes effective when set for a full slot.
- Initial W.O.C. to be set with dial indicator (K-Tool Inc. will set width at no charge before shipping).

Tool #	Cartridge	Wedge	Wedge Screw	Insert
SCSM-401	#2522C-RH/LH	#3	#10	SPEB-2522P
SCSM-501				
SCSM-601				
SCSM-801				

45° Cartridge

Cart. #	2522C-45
Insert	SPEB-2522P

Positive Top Insert

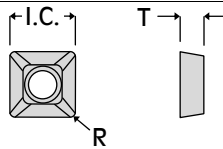

Insert Info.

Insert #	I.C.	T	R	Screw	Wrench	Grades
SPEB-2522P	.312	.125	.031	314T	T-8	A9M B1M X33 X40

Speed and Feed Info.

Material	S.F.M.	I.P.T.
Mild & Low Carbon Steel Ex. 1018, 1020, 1117, 1141, 12L14	800 - 1200	.002 - .006
High Carbon & Alloy Steel Ex. 1045, 4140, 4340, 52100, 8620	500 - 800	.002 - .005
Lower Carbon Tool Steel Ex. P-20, H-13, S-7	400 - 700	.002 - .005
Tool Steel Ex. A-2, A-6, D-2, M-2	300 - 600	.002 - .004
Stainless Steel Ex. 304, 316, 420, 15-5PH, 17-4PH	300 - 600	.002 - .004
Iron Ex. Cast, Ductile, Nodular	600 - 1000	.003 - .007
Nickel & Titanium Alloy Ex. Inconel, Hastelloy, Ti-6AL-4V	120 - 180	.001 - .003
Non-Ferrous Metal Ex. Aluminum, Bronze, Brass	1000 - 2500	.003 - .008

Arbor Mount

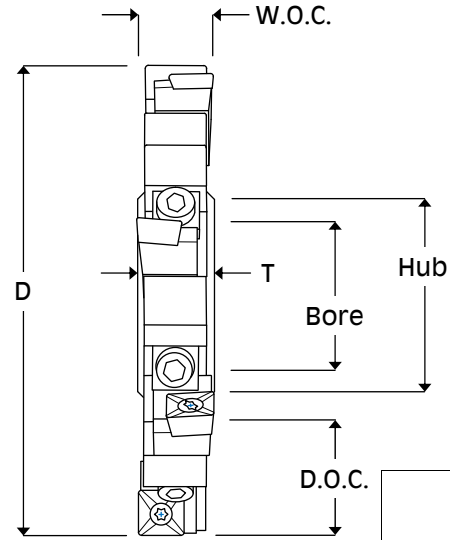

Series #2

Cutters can be used as: Half Side Mill (RH or LH)
Full Slot Mill (W.O.C. Required)

Tool Info.

Tool #	D	Flutes	W.O.C.	D.O.C.	Bore	Key	Hub	T
SC-402	4.000	8	.530 - .687	1.090	1.250	.312	1.630	.625
SC-502	5.000	10		1.590	1.250	.312	1.630	.625
SC-602	6.000	12		1.900	1.500	.375	2.000	.625
SC-802	8.000	16		2.900	1.500	.375	2.000	.625
SC-1002	10.000	16		3.900	1.500	.375	2.000	.625

Notes:

- Tool must be run as 1/2 the number of flutes effective when set for a full slot.
- Initial W.O.C. to be set with dial indicator (K-Tool Inc. will set width at no charge before shipping).

Tool #	Cartridge	Wedge	Wedge Screw	Insert
SC-402	#332C-RH/LH	#3	#10	SPEB-332P
SC-502				
SC-602				
SC-802				
SC-1002				

Speed and Feed Info.

Material	S.F.M.	I.P.T.
Mild & Low Carbon Steel Ex. 1018, 1020, 1117, 1141, 12L14	800 - 1200	.002 - .006
High Carbon & Alloy Steel Ex. 1045, 4140, 4340, 52100, 8620	500 - 800	.002 - .005
Lower Carbon Tool Steel Ex. P-20, H-13, S-7	400 - 700	.002 - .005
Tool Steel Ex. A-2, A-6, D-2, M-2	300 - 600	.002 - .004
Stainless Steel Ex. 304, 316, 420, 15-5PH, 17-4PH	300 - 600	.002 - .004
Iron Ex. Cast, Ductile, Nodular	600 - 1000	.003 - .007
Nickel & Titanium Alloy Ex. Inconel, Hastelloy, Ti-6AL-4V	120 - 180	.001 - .003
Non-Ferrous Metal Ex. Aluminum, Bronze, Brass	1000 - 2500	.003 - .008

Positive Top Insert

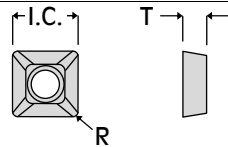

Insert Info.

Insert #	I.C.	T	R	Screw	Wrench	Grades
SPEB-332P	.375	.187	.031	538T	T-10	A9M B1M X33 X40

Shell Mount

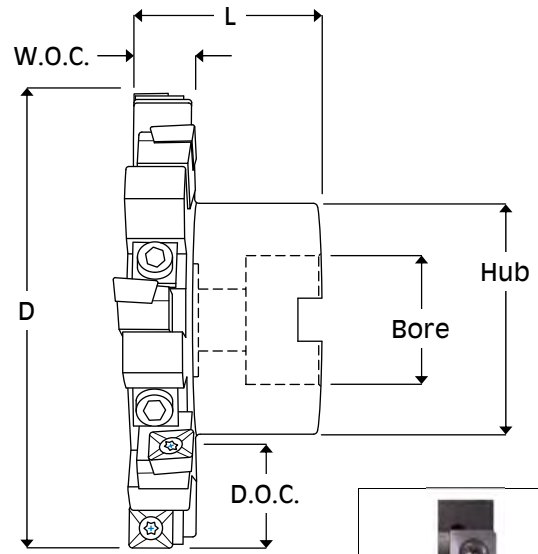

Series #2

Cutters can be used as: Half Side Mill (RH or LH)
Full Slot Mill (W.O.C. Required)

Tool Info.

Tool #	D	Flutes	W.O.C.	D.O.C.	Bore	Key	Hub	L
SCSM-402	4.000	8	.530 - .687	.875	1.000	.375	2.000	1.625
SCSM-502	5.000	10		1.062	1.250	.500	2.625	1.750
SCSM-602	6.000	12		1.000	1.500	.625	3.800	2.250
SCSM-802	8.000	16		1.975	1.500	.625	3.800	2.250

Notes:

- Tool must be run as 1/2 the number of flutes effective when set for a full slot.
- Initial W.O.C. to be set with dial indicator (K-Tool Inc. will set width at no charge before shipping).

Tool #	Cartridge	Wedge	Wedge Screw	Insert
SCSM-402	#332C-RH/LH	#3	#10	SPEB-332P
SCSM-502				
SCSM-602				
SCSM-802				

Speed and Feed Info.

Material	S.F.M.	I.P.T.
Mild & Low Carbon Steel Ex. 1018, 1020, 1117, 1141, 12L14	800 - 1200	.002 - .006
High Carbon & Alloy Steel Ex. 1045, 4140, 4340, 52100, 8620	500 - 800	.002 - .005
Lower Carbon Tool Steel Ex. P-20, H-13, S-7	400 - 700	.002 - .005
Tool Steel Ex. A-2, A-6, D-2, M-2	300 - 600	.002 - .004
Stainless Steel Ex. 304, 316, 420, 15-5PH, 17-4PH	300 - 600	.002 - .004
Iron Ex. Cast, Ductile, Nodular	600 - 1000	.003 - .007
Nickel & Titanium Alloy Ex. Inconel, Hastelloy, Ti-6AL-4V	120 - 180	.001 - .003
Non-Ferrous Metal Ex. Aluminum, Bronze, Brass	1000 - 2500	.003 - .008

Positive Top Insert

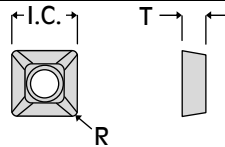

Insert Info.

Insert #	I.C.	T	R	Screw	Wrench	Grades
SPEB-332P	.375	.187	.031	538T	T-10	A9M B1M X33 X40

Arbor Mount

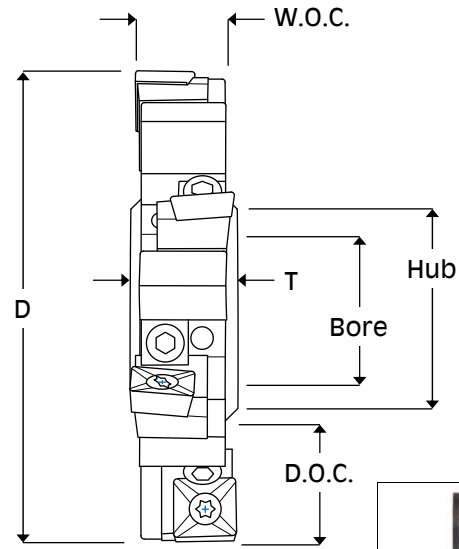

L.H. Cartridge



R.H. Cartridge

Series #3

Cutters can be used as: Half Side Mill (RH or LH)
Full Slot Mill (W.O.C. Required)

Tool Info.

Tool #	D	Flutes	W.O.C.	D.O.C.	Bore	Key	Hub	T
SC-403	4.000	8	.687 - .937	1.060	1.250	.312	1.630	.875
SC-503	5.000	10		1.560	1.250	.312	1.630	.875
SC-603	6.000	12		1.870	1.500	.375	2.000	.875
SC-803	8.000	16		2.870	1.500	.375	2.000	.875
SC-1003	10.000	16		3.870	1.500	.375	2.000	.875

Notes:

- Tool must be run as 1/2 the number of flutes effective when set for a full slot.
- Initial W.O.C. to be set with dial indicator (K-Tool Inc. will set width at no charge before shipping).

Tool #	Cartridge	Wedge	Wedge Screw	Insert
SC-403	#432C-RH/LH	#3	#10	SPEB-432PA
SC-503				
SC-603				
SC-803				
SC-1003				

45° Cartridge

Cart. #	432C-45
Insert	SPEB-432PA

Speed and Feed Info.

Material	S.F.M.	I.P.T.
Mild & Low Carbon Steel <i>Ex. 1018, 1020, 1117, 1141, 12L14</i>	800 - 1200	.002 - .006
High Carbon & Alloy Steel <i>Ex. 1045, 4140, 4340, 52100, 8620</i>	500 - 800	.002 - .005
Lower Carbon Tool Steel <i>Ex. P-20, H-13, S-7</i>	400 - 700	.002 - .005
Tool Steel <i>Ex. A-2, A-6, D-2, M-2</i>	300 - 600	.002 - .004
Stainless Steel <i>Ex. 304, 316, 420, 15-5PH, 17-4PH</i>	300 - 600	.002 - .004
Iron <i>Ex. Cast, Ductile, Nodular</i>	600 - 1000	.003 - .007
Nickel & Titanium Alloy <i>Ex. Inconel, Hastelloy, Ti-6AL-4V</i>	120 - 180	.001 - .003
Non-Ferrous Metal <i>Ex. Aluminum, Bronze, Brass</i>	1000 - 2500	.003 - .008

Positive Top Insert

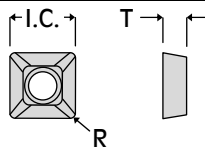

Insert Info.

Insert #	I.C.	T	R	Screw	Wrench	Grades
SPEB-432PA	.500	.187	.031	638T	T-15	A9M B1M X33 X40

Shell Mount

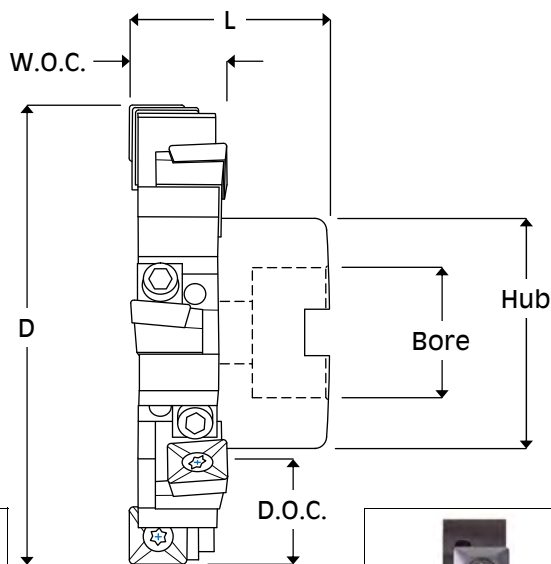

L.H. Cartridge



R.H. Cartridge

Series #3

Cutters can be used as: Half Side Mill (RH or LH)
Full Slot Mill (W.O.C. Required)

Tool Info.

Tool #	D	Flutes	W.O.C.	D.O.C.	Bore	Key	Hub	L
SCSM-403	4.000	8	.687 - .937	.875	1.000	.375	2.000	1.625
SCSM-503	5.000	10		1.062	1.250	.500	2.625	1.750
SCSM-603	6.000	12		1.000	1.500	.625	3.800	2.250
SCSM-803	8.000	16		1.975	1.500	.625	3.800	2.250

Notes:

- Tool must be run as 1/2 the number of flutes effective when set for a full slot.
- Initial W.O.C. to be set with dial indicator (K-Tool Inc. will set width at no charge before shipping).

Tool #	Cartridge	Wedge	Wedge Screw	Insert
SCSM-403	#432C-RH/LH	#3	#10	SPEB-432PA
SCSM-503				
SCSM-603				
SCSM-803				

45° Cartridge

Cart. #	432C-45
Insert	SPEB-432PA

Speed and Feed Info.

Material	S.F.M.	I.P.T.
Mild & Low Carbon Steel Ex. 1018, 1020, 1117, 1141, 12L14	800 - 1200	.002 - .006
High Carbon & Alloy Steel Ex. 1045, 4140, 4340, 52100, 8620	500 - 800	.002 - .005
Lower Carbon Tool Steel Ex. P-20, H-13, S-7	400 - 700	.002 - .005
Tool Steel Ex. A-2, A-6, D-2, M-2	300 - 600	.002 - .004
Stainless Steel Ex. 304, 316, 420, 15-5PH, 17-4PH	300 - 600	.002 - .004
Iron Ex. Cast, Ductile, Nodular	600 - 1000	.003 - .007
Nickel & Titanium Alloy Ex. Inconel, Hastelloy, Ti-6AL-4V	120 - 180	.001 - .003
Non-Ferrous Metal Ex. Aluminum, Bronze, Brass	1000 - 2500	.003 - .008

Positive Top Insert

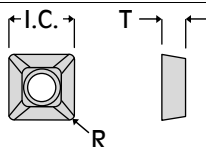

Insert Info.

Insert #	I.C.	T	R	Screw	Wrench	Grades
SPEB-432PA	.500	.187	.031	638T	T-15	A9M B1M X33 X40

Arbor Mount

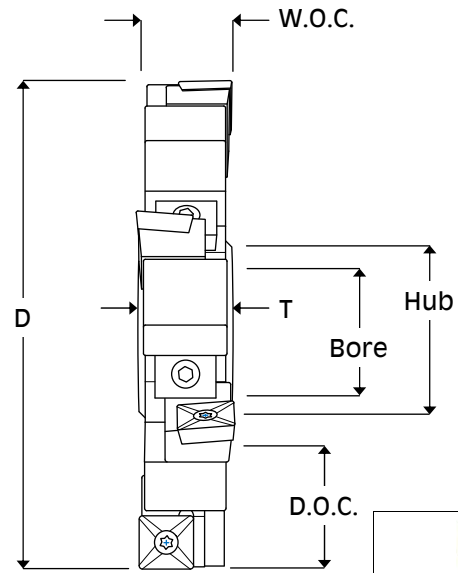

Series #4

Cutters can be used as: Half Side Mill (RH or LH)
Full Slot Mill (W.O.C. Required)

Tool Info.								
Tool #	D	Flutes	W.O.C.	D.O.C.	Bore	Key	Hub	T
SC-604	6.000	8	.937 - 1.187	1.870	1.500	.375	2.000	1.100
SC-804	8.000	12		2.870	1.500	.375	2.000	1.100
SC-1004	10.000	14		3.870	1.500	.375	2.000	1.100

Notes:

- Tool must be run as 1/2 the number of flutes effective when set for a full slot.
- Initial W.O.C. to be set with dial indicator (K-Tool Inc. will set width at no charge before shipping).

Tool #	Cartridge	Wedge	Wedge Screw	Insert
SC-604				
SC-804	#532C-RH/LH	#4	#5161D	SPEB-532PA
SC-1004				

Positive Top Insert						
Insert #	I.C.	T	R	Screw	Wrench	Grade
SPEB-532PA	.625	.187	.031	838T	T-20	X33

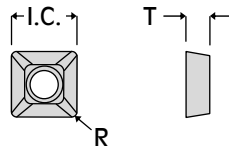

Insert Info.

Speed and Feed Info.		
Material	S.F.M.	I.P.T.
Mild & Low Carbon Steel Ex. 1018, 1020, 1117, 1141, 12L14	800 - 1200	.002 - .006
High Carbon & Alloy Steel Ex. 1045, 4140, 4340, 52100, 8620	500 - 800	.002 - .005
Lower Carbon Tool Steel Ex. P-20, H-13, S-7	400 - 700	.002 - .005
Tool Steel Ex. A-2, A-6, D-2, M-2	300 - 600	.002 - .004
Stainless Steel Ex. 304, 316, 420, 15-5PH, 17-4PH	300 - 600	.002 - .004
Iron Ex. Cast, Ductile, Nodular	600 - 1000	.003 - .007
Nickel & Titanium Alloy Ex. Inconel, Hastelloy, Ti-6AL-4V	120 - 180	.001 - .003
Non-Ferrous Metal Ex. Aluminum, Bronze, Brass	1000 - 2500	.003 - .008

Shell Mount

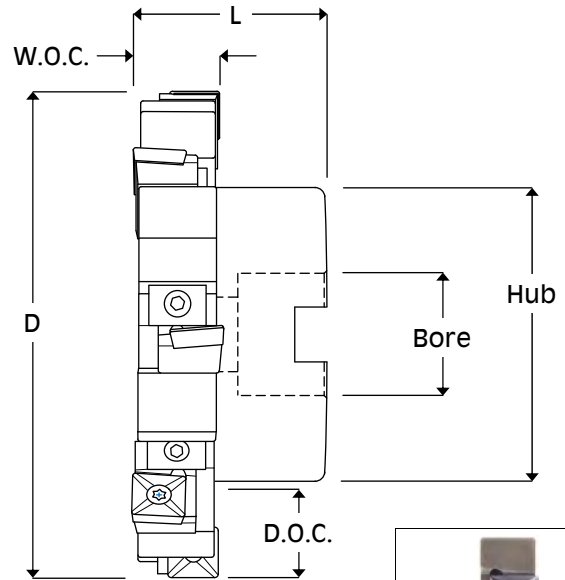

Series #4

Cutters can be used as: Half Side Mill (RH or LH)
Full Slot Mill (W.O.C. Required)

Tool Info.								
Tool #	D	Flutes	W.O.C.	D.O.C.	Bore	Key	Hub	L
SCSM-504	5.000	6	.937 - 1.187	1.062	1.250	.500	2.625	1.750
SCSM-604	6.000	8		1.012	1.500	.625	3.625	2.250
SCSM-804	8.000	12		1.975	1.500	.625	3.800	2.250

Notes:

- Tool must be run as 1/2 the number of flutes effective when set for a full slot.
- Initial W.O.C. to be set with dial indicator (K-Tool Inc. will set width at no charge before shipping).

Tool #	Cartridge	Wedge	Wedge Screw	Insert
SCSM-504				
SCSM-604	#532C-RH/LH	#4	#5161D	SPEB-532PA
SCSM-808				

Positive Top Insert						
Insert #	I.C.	T	R	Screw	Wrench	Grade
SPEB-532PA	.625	.187	.031	838T	T-20	X33

Speed and Feed Info.		
Material	S.F.M.	I.P.T.
Mild & Low Carbon Steel Ex. 1018, 1020, 1117, 1141, 12L14	800 - 1200	.002 - .006
High Carbon & Alloy Steel Ex. 1045, 4140, 4340, 52100, 8620	500 - 800	.002 - .005
Lower Carbon Tool Steel Ex. P-20, H-13, S-7	400 - 700	.002 - .005
Tool Steel Ex. A-2, A-6, D-2, M-2	300 - 600	.002 - .004
Stainless Steel Ex. 304, 316, 420, 15-5PH, 17-4PH	300 - 600	.002 - .004
Iron Ex. Cast, Ductile, Nodular	600 - 1000	.003 - .007
Nickel & Titanium Alloy Ex. Inconel, Hastelloy, Ti-6AL-4V	120 - 180	.001 - .003
Non-Ferrous Metal Ex. Aluminum, Bronze, Brass	1000 - 2500	.003 - .008

Radius Slotting Cutters

Full Radius Cartridge Style Cutters

Available in .250 - .375 - .500 - .750 W.O.C.



Available in Arbor Mount
or Shell Mount

2 Insert Styles Available

Applications

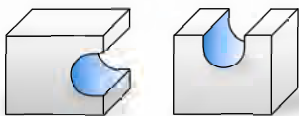

Arbor Mount

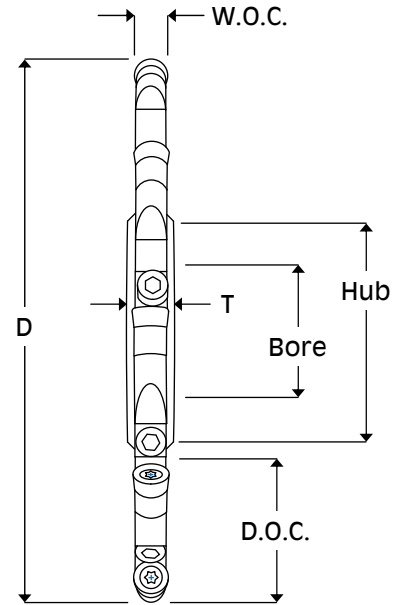

#22R Cartridge

Series #2

Tool Info.

Tool #	D	Flutes	W.O.C.	D.O.C.	Bore	Key	Hub	T
SCR-402	4.000	10	.250	1.090	1.250	.312	1.620	.340
SCR-502	5.000	12		1.590	1.250	.312	1.620	.340
SCR-602	6.000	14		1.900	1.500	.375	2.000	.340

Tool #	Cartridge	Wedge	Wedge Screw	Molded Insert	Ground Insert
SCR-402	#22R	#15	#612	RCEB-22	RCEB-22G
SCR-502					
SCR-602					

Note:

Cartridges will be preset in body before shipping at no extra charge.

Speed and Feed Info.

Material	S.F.M.	I.P.T.
Mild & Low Carbon Steel Ex. 1018, 1020, 1117, 1141, 12L14	800 - 1200	.002 - .006
High Carbon & Alloy Steel Ex. 1045, 4140, 4340, 52100, 8620	500 - 800	.002 - .005
Lower Carbon Tool Steel Ex. P-20, H-13, S-7	400 - 700	.002 - .005
Tool Steel Ex. A-2, A-6, D-2, M-2	300 - 600	.002 - .004
Stainless Steel Ex. 304, 316, 420, 15-5PH, 17-4PH	300 - 600	.002 - .004
Iron Ex. Cast, Ductile, Nodular	600 - 1000	.003 - .007
Nickel & Titanium Alloy Ex. Inconel, Hastelloy, Ti-6AL-4V	120 - 180	.001 - .003
Non-Ferrous Metal Ex. Aluminum, Bronze, Brass	1000 - 2500	.003 - .008

Positive Top Inserts

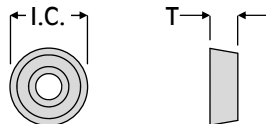

Insert Info.

Insert #	I.C.	T	Screw	Wrench	Grades
RCEB-22	.250	.125	314T	T-8	A10M X33
RCEB-22G	.250	.125	314T	T-8	B1M X33

Shell Mount

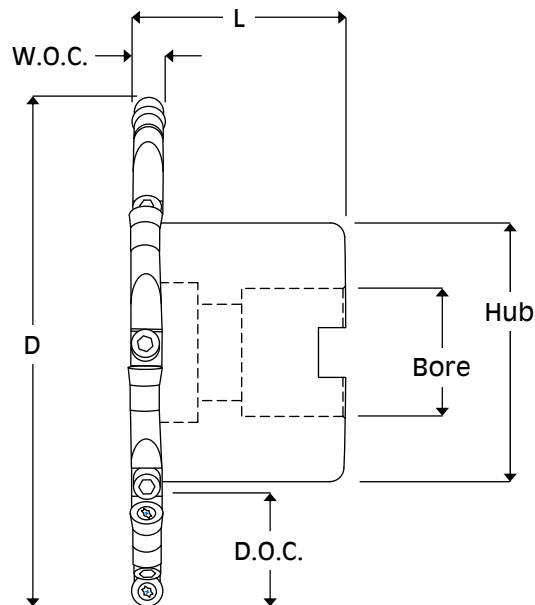

Series #2

Tool Info.

Tool #	D	Flutes	W.O.C.	D.O.C.	Bore	Key	Hub	L
SCRSM-402	4.000	10	.250	.875	1.000	.375	2.000	1.625
SCRSM-502	5.000	12		1.062	1.250	.500	2.625	1.750
SCRSM-602	6.000	14		.937	1.500	.625	3.800	2.250

Tool #	Cartridge	Wedge	Wedge Screw	Molded Insert	Ground Insert
SCRSM-402	#22R	#15	#612	RCEB-22	RCEB-22G
SCRSM-502					
SCRSM-602					

Note:
Cartridges will be preset in body before shipping at no extra charge.

Speed and Feed Info.

Material	S.F.M.	I.P.T.
Mild & Low Carbon Steel Ex. 1018, 1020, 1117, 1141, 12L14	800 - 1200	.002 - .006
High Carbon & Alloy Steel Ex. 1045, 4140, 4340, 52100, 8620	500 - 800	.002 - .005
Lower Carbon Tool Steel Ex. P-20, H-13, S-7	400 - 700	.002 - .005
Tool Steel Ex. A-2, A-6, D-2, M-2	300 - 600	.002 - .004
Stainless Steel Ex. 304, 316, 420, 15-5PH, 17-4PH	300 - 600	.002 - .004
Iron Ex. Cast, Ductile, Nodular	600 - 1000	.003 - .007
Nickel & Titanium Alloy Ex. Inconel, Hastelloy, Ti-6AL-4V	120 - 180	.001 - .003
Non-Ferrous Metal Ex. Aluminum, Bronze, Brass	1000 - 2500	.003 - .008

Positive Top Inserts

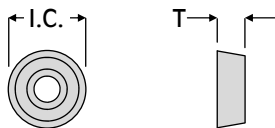

Insert Info.

Insert #	I.C.	T	Screw	Wrench	Grades
RCEB-22	.250	.125	314T	T-8	A10M X33
RCEB-22G	.250	.125	314T	T-8	B1M X33

Arbor Mount

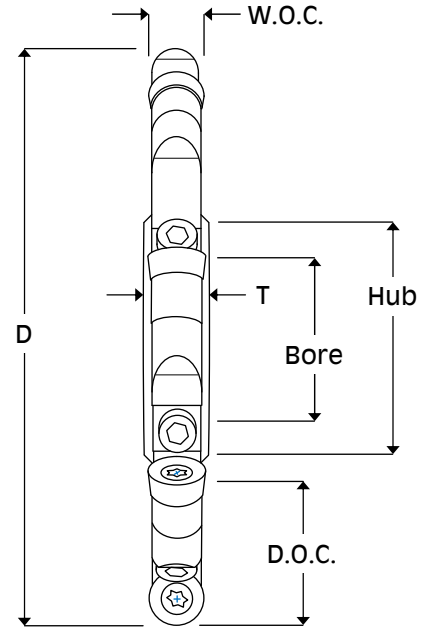

Series #3

Tool Info.

Tool #	D	Flutes	W.O.C.	D.O.C.	Bore	Key	Hub	T
SCR-403	4.000	8	.375	1.090	1.250	.312	1.620	.430
SCR-503	5.000	10		1.590	1.250	.312	1.620	.430
SCR-603	6.000	12		1.900	1.500	.375	2.000	.430
SCR-803	8.000	16		2.900	1.500	.375	2.000	.430

Tool #	Cartridge	Wedge	Wedge Screw	Molded Insert	Ground Insert
SCR-403	#325R	#2	#8	RCEB-325	RCEB-325G
SCR-503					
SCR-603					
SCR-803					

Note:
Cartridges will be preset in body before shipping at no extra charge.

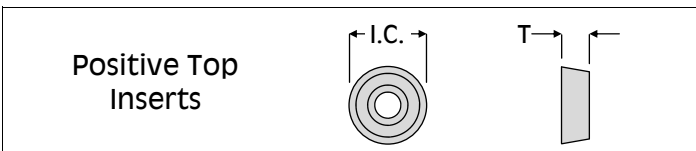

Insert Info.

Insert #	I.C.	T	Screw	Wrench	Grades
RCEB-325	.375	.156	538T	T-10	A10M X33
RCEB-325G	.375	.156	538T	T-10	B1M X33

Speed and Feed Info.

Material	S.F.M.	I.P.T.
Mild & Low Carbon Steel Ex. 1018, 1020, 1117, 1141, 12L14	800 - 1200	.002 - .006
High Carbon & Alloy Steel Ex. 1045, 4140, 4340, 52100, 8620	500 - 800	.002 - .005
Lower Carbon Tool Steel Ex. P-20, H-13, S-7	400 - 700	.002 - .005
Tool Steel Ex. A-2, A-6, D-2, M-2	300 - 600	.002 - .004
Stainless Steel Ex. 304, 316, 420, 15-5PH, 17-4PH	300 - 600	.002 - .004
Iron Ex. Cast, Ductile, Nodular	600 - 1000	.003 - .007
Nickel & Titanium Alloy Ex. Inconel, Hastelloy, Ti-6AL-4V	120 - 180	.001 - .003
Non-Ferrous Metal Ex. Aluminum, Bronze, Brass	1000 - 2500	.003 - .008

Shell Mount

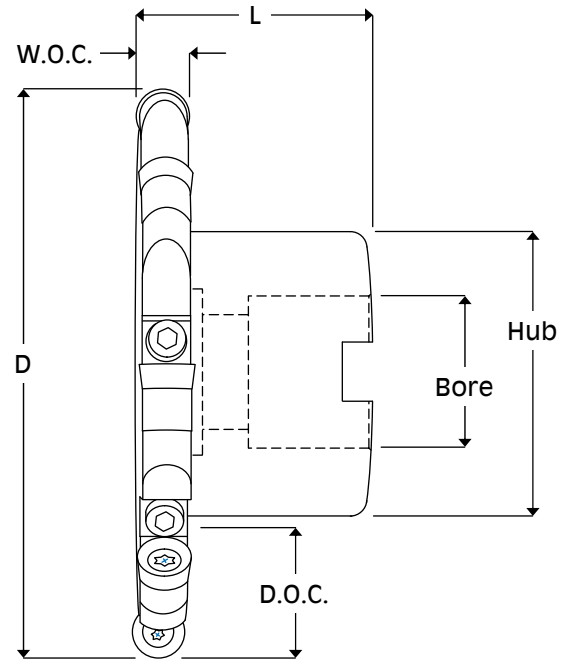

Series #3

#325R Cartridge

Tool Info.

Tool #	D	Flutes	W.O.C.	D.O.C.	Bore	Key	Hub	L
SCRSM-403	4.000	8	.375	.875	1.000	.375	2.000	1.625
SCRSM-503	5.000	10		1.062	1.250	.500	2.625	1.750
SCRSM-603	6.000	12		.937	1.500	.625	3.800	2.250
SCRSM-803	8.000	16		2.000	1.500	.625	3.800	2.250

Tool #	Cartridge	Wedge	Wedge Screw	Molded Insert	Ground Insert
SCRSM-403	#325R	#2	#8	RCEB-325	RCEB-325G
SCRSM-503					
SCRSM-603					
SCRSM-803					

Note:
Cartridges will be preset in body before shipping at no extra charge.

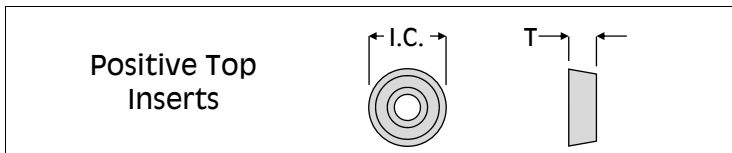

Insert Info.

Insert #	I.C.	T	Screw	Wrench	Grades
RCEB-325	.375	.156	538T	T-10	A10M X33
RCEB-325G	.375	.156	538T	T-10	B1M X33

Speed and Feed Info.

Material	S.F.M.	I.P.T.
Mild & Low Carbon Steel Ex. 1018, 1020, 1117, 1141, 12L14	800 - 1200	.002 - .006
High Carbon & Alloy Steel Ex. 1045, 4140, 4340, 52100, 8620	500 - 800	.002 - .005
Lower Carbon Tool Steel Ex. P-20, H-13, S-7	400 - 700	.002 - .005
Tool Steel Ex. A-2, A-6, D-2, M-2	300 - 600	.002 - .004
Stainless Steel Ex. 304, 316, 420, 15-5PH, 17-4PH	300 - 600	.002 - .004
Iron Ex. Cast, Ductile, Nodular	600 - 1000	.003 - .007
Nickel & Titanium Alloy Ex. Inconel, Hastelloy, Ti-6AL-4V	120 - 180	.001 - .003
Non-Ferrous Metal Ex. Aluminum, Bronze, Brass	1000 - 2500	.003 - .008

Arbor Mount

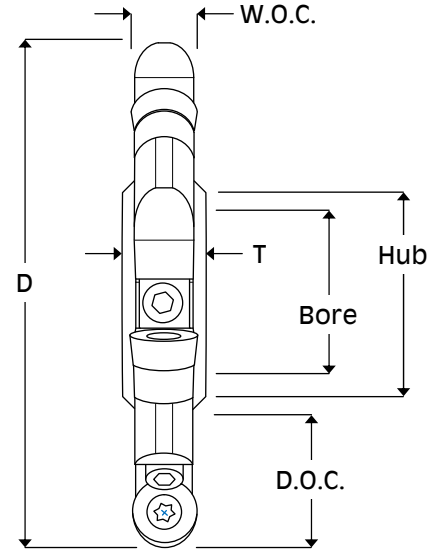

#435R Cartridge

Series #4

Tool Info.

Tool #	D	Flutes	W.O.C.	D.O.C.	Bore	Key	Hub	T
SCR-404	4.000	6	.500	1.090	1.250	.312	1.620	.625
SCR-504	5.000	8		1.590	1.250	.312	1.620	.625
SCR-604	6.000	10		1.900	1.500	.375	2.000	.625
SCR-804	8.000	12		2.900	1.500	.375	2.000	.625
SCR-1004	10.000	16		3.900	1.500	.375	2.000	.625

Tool #	Cartridge	Wedge	Wedge Screw	Molded Insert	Ground Insert
SCR-404	#435R	#3	#10	RCEB-435	RCEB-435G
SCR-504					
SCR-604					
SCR-804					
SCR-1004					

Note:

Cartridges will be preset in body before shipping at no extra charge.

Positive Top Inserts

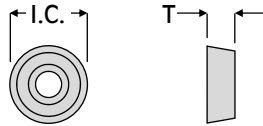

Insert Info.

Insert #	I.C.	T	Screw	Wrench	Grades
RCEB-435	.500	.220	838T	T-20	A10M X33
RCEB-435G	.500	.220	838T	T-20	B1M X33

Speed and Feed Info.

Material	S.F.M.	I.P.T.
Mild & Low Carbon Steel Ex. 1018, 1020, 1117, 1141, 12L14	800 - 1200	.002 - .006
High Carbon & Alloy Steel Ex. 1045, 4140, 4340, 52100, 8620	500 - 800	.002 - .005
Lower Carbon Tool Steel Ex. P-20, H-13, S-7	400 - 700	.002 - .005
Tool Steel Ex. A-2, A-6, D-2, M-2	300 - 600	.002 - .004
Stainless Steel Ex. 304, 316, 420, 15-5PH, 17-4PH	300 - 600	.002 - .004
Iron Ex. Cast, Ductile, Nodular	600 - 1000	.003 - .007
Nickel & Titanium Alloy Ex. Inconel, Hastelloy, Ti-6AL-4V	120 - 180	.001 - .003
Non-Ferrous Metal Ex. Aluminum, Bronze, Brass	1000 - 2500	.003 - .008

Shell Mount

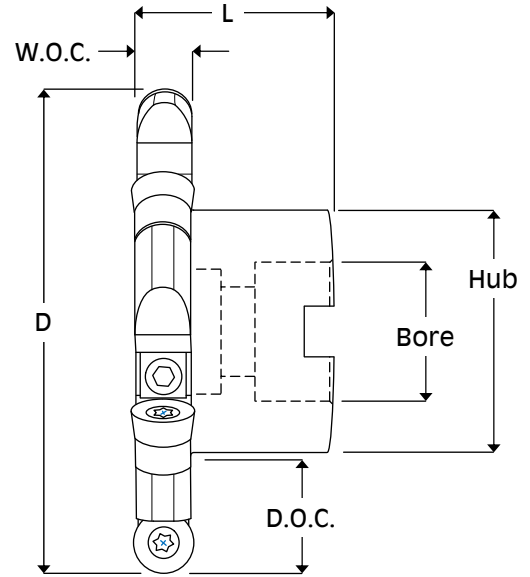

Series #4

Tool Info.

Tool #	D	Flutes	W.O.C.	D.O.C.	Bore	Key	Hub	L
SCRSM-404	4.000	6	.500	.875	1.000	.375	2.000	1.625
SCRSM-504	5.000	8		1.062	1.250	.500	2.625	1.750
SCRSM-604	6.000	10		.937	1.500	.625	3.800	2.250
SCRSM-804	8.000	12		2.000	1.500	.625	3.800	2.250

Tool #	Cartridge	Wedge	Wedge Screw	Molded Insert	Ground Insert
SCRSM-404	#435R	#3	#10	RCEB-435	RCEB-435G
SCRSM-504					
SCRSM-604					
SCRSM-804					

Note:
Cartridges will be preset in body before shipping at no extra charge.

Speed and Feed Info.

Material	S.F.M.	I.P.T.
Mild & Low Carbon Steel Ex. 1018, 1020, 1117, 1141, 12L14	800 - 1200	.002 - .006
High Carbon & Alloy Steel Ex. 1045, 4140, 4340, 52100, 8620	500 - 800	.002 - .005
Lower Carbon Tool Steel Ex. P-20, H-13, S-7	400 - 700	.002 - .005
Tool Steel Ex. A-2, A-6, D-2, M-2	300 - 600	.002 - .004
Stainless Steel Ex. 304, 316, 420, 15-5PH, 17-4PH	300 - 600	.002 - .004
Iron Ex. Cast, Ductile, Nodular	600 - 1000	.003 - .007
Nickel & Titanium Alloy Ex. Inconel, Hastelloy, Ti-6AL-4V	120 - 180	.001 - .003
Non-Ferrous Metal Ex. Aluminum, Bronze, Brass	1000 - 2500	.003 - .008

Positive Top Inserts

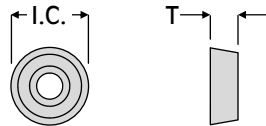

Insert Info.

Insert #	I.C.	T	Screw	Wrench	Grades
RCEB-435	.500	.220	838T	T-20	A10M X33
RCEB-435G	.500	.220	838T	T-20	B1M X33

Arbor Mount

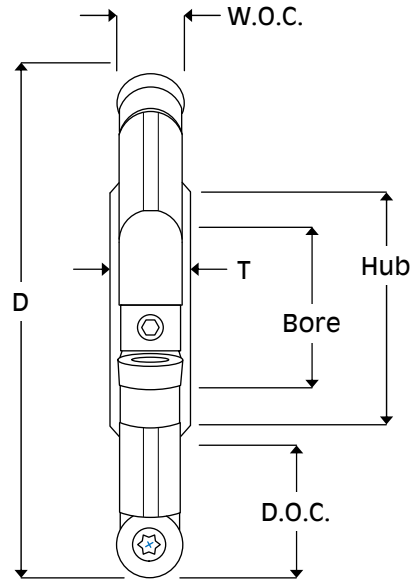

Series #5

Tool Info.

Tool #	D	Flutes	W.O.C.	D.O.C.	Bore	Key	Hub	T
SCR-605	6.000	5	.750	1.687	1.500	.375	2.000	1.000
SCR-805	8.000	7		2.687	1.500	.375	2.000	1.000
SCR-1005	10.000	8		3.687	1.500	.375	2.000	1.000

Tool #	Cartridge	Wedge	Wedge Screw	Insert
SCR-605	#64R	#4	#5161D	RCEB-64
SCR-805				
SCR-1005				

Note:

Cartridges will be preset in body before shipping at no extra charge.

Positive Top Insert

Insert Info.					
Insert #	I.C.	T	Screw	Wrench	Grades
RCEB-64	.750	.250	1012T	T-25	A10M X33

Speed and Feed Info.

Material	S.F.M.	I.P.T.
Mild & Low Carbon Steel Ex. 1018, 1020, 1117, 1141, 12L14	800 - 1200	.002 - .006
High Carbon & Alloy Steel Ex. 1045, 4140, 4340, 52100, 8620	500 - 800	.002 - .005
Lower Carbon Tool Steel Ex. P-20, H-13, S-7	400 - 700	.002 - .005
Tool Steel Ex. A-2, A-6, D-2, M-2	300 - 600	.002 - .004
Stainless Steel Ex. 304, 316, 420, 15-5PH, 17-4PH	300 - 600	.002 - .004
Iron Ex. Cast, Ductile, Nodular	600 - 1000	.003 - .007
Nickel & Titanium Alloy Ex. Inconel, Hastelloy, TI-6AL-4V	120 - 180	.001 - .003
Non-Ferrous Metal Ex. Aluminum, Bronze, Brass	1000 - 2500	.003 - .008

Shell Mount

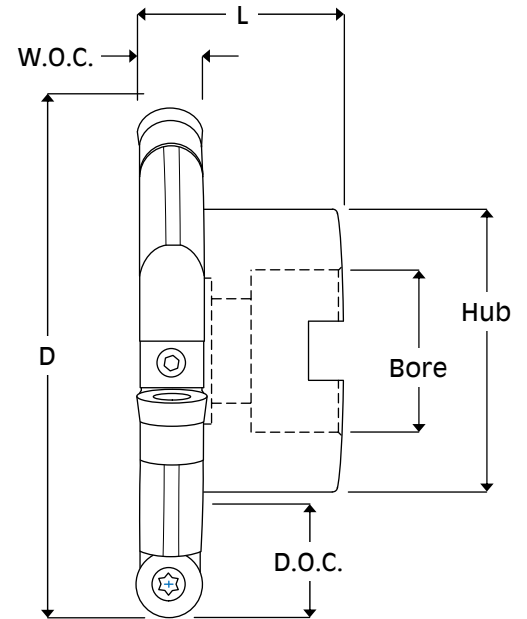

Series #5

Tool Info.

Tool #	D	Flutes	W.O.C.	D.O.C.	Bore	Key	Hub	L
SCRSM-605	6.000	5	.750	1.250	1.500	.625	3.200	2.250
SCRSM-805	8.000	7		2.000	1.500	.625	3.800	2.250
SCRSM-1005	10.000	8		3.000	1.500	.625	3.800	2.875

Tool #	Cartridge	Wedge	Wedge Screw	Insert
SCRSM-605	#64R	#4	#5161D	RCEB-64
SCRSM-805				
SCRSM-1005				

Note:
Cartridges will be preset in body before shipping at no extra charge.

Positive Top Insert					
Insert Info.					
Insert #	I.C.	T	Screw	Wrench	Grades
RCEB-64	.750	.250	1012T	T-25	A10M X33

Speed and Feed Info.

Material	S.F.M.	I.P.T.
Mild & Low Carbon Steel Ex. 1018, 1020, 1117, 1141, 12L14	800 - 1200	.002 - .006
High Carbon & Alloy Steel Ex. 1045, 4140, 4340, 52100, 8620	500 - 800	.002 - .005
Lower Carbon Tool Steel Ex. P-20, H-13, S-7	400 - 700	.002 - .005
Tool Steel Ex. A-2, A-6, D-2, M-2	300 - 600	.002 - .004
Stainless Steel Ex. 304, 316, 420, 15-5PH, 17-4PH	300 - 600	.002 - .004
Iron Ex. Cast, Ductile, Nodular	600 - 1000	.003 - .007
Nickel & Titanium Alloy Ex. Inconel, Hastelloy, Ti-6AL-4V	120 - 180	.001 - .003
Non-Ferrous Metal Ex. Aluminum, Bronze, Brass	1000 - 2500	.003 - .008

Screw Torque Info.

All Torque Specs are in IN/LB

Screw #	Torx Size	Recommended Torque	Max Torque
164T	T-6	2.7 - 3.3	5.5
300T	T-8	5.7 - 6.8	11.3
314T	T-8	5.7 - 6.8	11.3
414T	T-10	10 - 11.9	19.9
438T	T-10	10 - 11.9	19.9
538T	T-10	10 - 11.9	19.9
560T	T-10	10 - 11.9	19.9
5625T	T-10	10 - 11.9	19.9
614T	T-15	15.3 - 18.3	30.5
638T	T-15	15.3 - 18.3	30.5
838T	T-20	22.8 - 27.4	45.6
1012T	T-25	33.6 - 40.4	67.3
1412T	5/32 Allen	77.4 - 92.9	154.9



Test Tool Request Form

To receive a test tool number, submit the completed information below to K-Tool, Inc. by Email, Fax or Phone. Our tech support staff will be in contact with you within 1 business day to provide a test tool number, or to get additional information needed to validate the test.
 Note: Test tool numbers will be issued for standard tools only.

The form can also be found on our website at www.ktoolinc.com under Technical Support.

Distributor Contact Information	
Distributor	
Salesperson	
Email	
Phone #	
Fax #	

End User Contact Information	
Company Name	
Contact	
Email	
Phone #	
Fax #	

Requested Test Tool	
Tool#	
Insert#	
Additional Information	

Material Information	
Material	
Hardness	
Additional Information	

Cutting Parameters	
Width of Cut	
Depth of Cut	
Length of cut	

Machine Information	
Machine Type	<input type="checkbox"/> Mill <input type="checkbox"/> Lathe
Horsepower	
Spindle Taper	
Coolant Thru	
Flood Coolant	
Coolant Pressure	

Tool Holder Information			
Holder Type	<input type="checkbox"/> Collet	<input type="checkbox"/> Milling Chuck	<input type="checkbox"/> End Mill Holder
Holder Length	<input type="checkbox"/> Stub Length	<input type="checkbox"/> Standard Length	<input type="checkbox"/> Extended Length
Projection Length			

Provide a brief description of how the tool will be used.

TEST TOOL POLICY

We will ship cutter bodies and inserts on performance purchase order numbers after the guaranteed test form information is supplied. K-TOOL, INC. will cover the tool bodies only. No credit will be given on used inserts, however credit will be issued on unused inserts. Items will be invoiced at the time of shipment. All test tools must be paid for or returned within 60 days.

K-Tool Inc.

99 Enterprise Drive
New Oxford, Pennsylvania 17350

Your Local K-Tool Inc. Distributor



Ph: 800-377-3056
Fax: 717-624-4105
E-Mail: info@ktoolinc.com