

# THINBIT®

SINCE 1964

888-THINBIT | 888-THINFAX | THINBIT.COM

GROOVING  
THREADING  
PARTING  
BORING  
TURNING  
FACE GROOVING  
CUSTOM TOOLING  
FORM TOOLING  
MILL TOOLING

2018

thinbit.com

MADE IN THE USA



## SECTION 1: GROOVING



GROOVING AND TURNING  
.004" THROUGH .150" IN  
.001" INCREMENTS

PG  
1-9



1.000" DEPTH OF CUT  
2, 3, 4, 5 AND 6MM  
INSERT WIDTHS

PG  
1-13



STATIC O-RING GROOVING WITH  
1.250" MINIMUM BORE DIAMETER

PG  
1-13

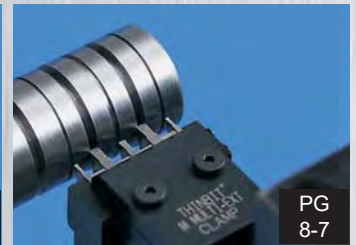

INTERNAL AND EXTERNAL  
MULTI - INSERT

PG  
8-7

## SECTION 2: FACE GROOVING



MAJOR DIAMETERS FROM .300"  
.004" THROUGH .150" IN  
.001" INCREMENTS

PG  
2-9



MAJOR DIAMETERS FROM .787";  
1" D.O.C.; 2, 3, 4, 5 AND  
6MM INSERT WIDTHS

PG  
2-15



MAJOR DIAMETERS FROM .300";  
FOR DOVETAIL O-RING  
FACE GROOVING

PG  
2-11



MAJOR DIAMETERS FROM .300"  
.004" THROUGH .150" IN  
.001" INCREMENTS

PG  
2-9

# THINBIT®

OVER 100,000 TOOLS IN STOCK FOR  
GROOVING • THREADING • PARTING  
BORING • TURNING • FACE GROOVING  
SPECIALS • FORM TOOLS

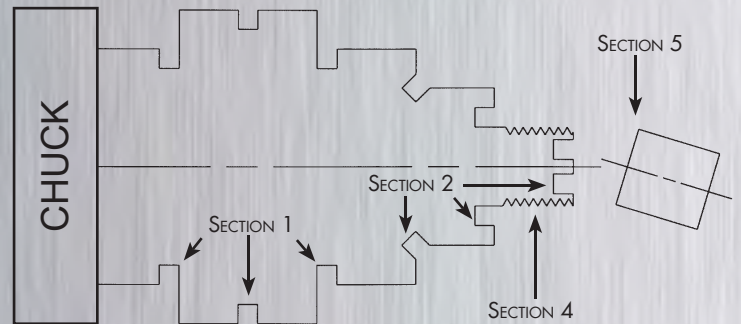

## SECTION 4: THREADING AND CHAMFERING

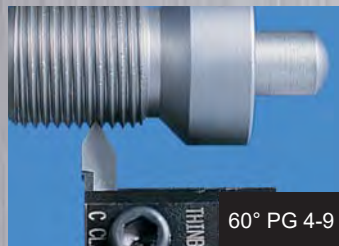

INTERNAL AND EXTERNAL THREADING  
8 THREADS PER INCH AND GREATER

60° PG  
4-9



ACME PG  
4-11

ACME EXTERNAL THREADING  
4 THREADS PER INCH AND GREATER



PG  
4-13

INTERNAL AND EXTERNAL  
CHAMFERING  
45°

## SECTION 5: PARTING



UP TO 1" MATERIAL  
.025", .045", .062", .085",  
.115" INSERT WIDTHS

PG  
5-3

## MADE IN USA SINCE 1964



KAISER TOOL COMPANY, INC.  
3620 CENTENNIAL DRIVE  
FORT WAYNE, IN 46808



WWW.THINBIT.COM/CATALOGHOWTO  
FOR INFORMATION ON HOW TO USE THIS  
CATALOG SCAN THIS CODE.



SECTION 1: GROOVING

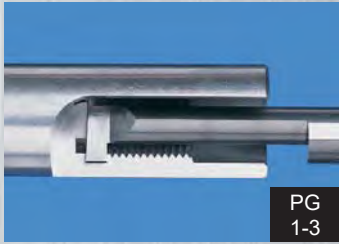

PG  
1-3

.125" MINIMUM BORE DIAMETER  
.004" THROUGH .250"  
IN .001" INCREMENTS



PG  
1-5

.325" MINIMUM BORE DIAMETER  
.004" THROUGH .125"  
IN .001" INCREMENTS



PG  
1-7

1.000" MINIMUM BORE DIAMETER;  
2MM, 3MM AND 4MM  
INSERT WIDTHS

SECTION 2: FACE GROOVING



PG  
2-3

MAJOR DIAMETERS FROM .125"  
.004" THROUGH .250"  
IN .001" INCREMENTS



PG  
2-5

MAJOR DIAMETERS FROM .415"  
.004" THROUGH .125"  
IN .001" INCREMENTS

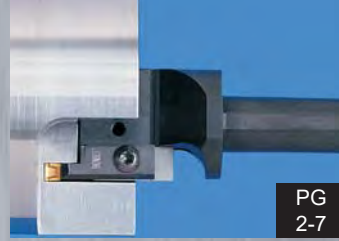

PG  
2-7

MAJOR DIAMETERS FROM 1.574"  
2, 3, 4, 5 AND 6MM  
INSERT WIDTHS

TOOLHOLDERS  
SECTION 7

MODIFICATIONS  
SECTION 8

TECHNICAL  
SECTION 9

LITTLEBIT®  
SECTION 10

FOR MORE COMPLETE  
APPLICATION REFERENCE  
CHARTS, REFER TO  
PAGES 9-3 & 9-4

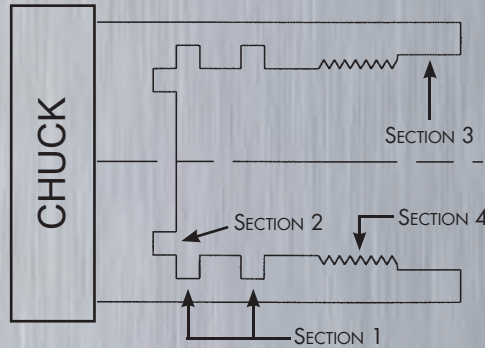

[www.thinbit.com](http://www.thinbit.com)  
E-MAIL: [thinbit@kaisertool.com](mailto:thinbit@kaisertool.com)  
ORDERS: [orders@thinbit.com](mailto:orders@thinbit.com)  
QUOTES: [quotes@thinbit.com](mailto:quotes@thinbit.com)

SECTION 3: BORING



PG  
3-3

.073" MINIMUM BORE DIAMETER  
SOLID CARBIDE TOOLING

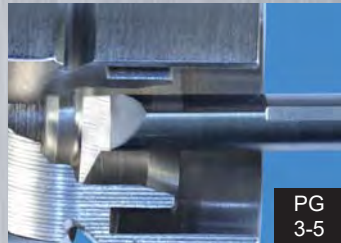

PG  
3-5

.125" MINIMUM BORE DIAMETER  
PROFILING  
SOLID CARBIDE TOOLING

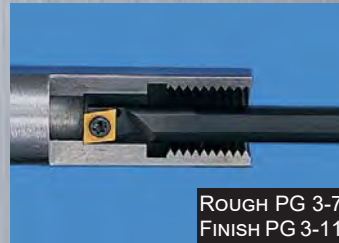

ROUGH PG 3-7  
FINISH PG 3-11

.165" MINIMUM BORE DIAMETER  
CD, TD, TP AND WCGT INSERT  
STYLES

Phone: 888-THINBIT  
(888-844-6248)  
(260) 484-3620  
Fax: 888-THINFAX  
(888-844-6329)  
(260) 482-1881

SECTION 4: THREADING



60° PG 4-3

.077" MINIMUM BORE DIAMETER  
4 THREADS PER INCH AND GREATER



PG  
4-7

.325" MINIMUM BORE DIAMETER  
9 THREADS PER INCH AND GREATER



ACME PG 4-5

.187" MINIMUM BORE DIAMETER  
6 THREADS PER INCH AND GREATER



**MORE  
TOOLS  
THAN  
YOU CAN  
SHAKE  
A LATHE AT**®

**THINBIT**®

COMPLETE TOOLING SOLUTIONS FOR  
GROOVING • THREADING • PARTING • BORING • TURNING  
FACE GROOVING • SPECIALS • FORM TOOLS

**We Can Do That!**®



# THINBIT®

## KAISER TOOL COMPANY, INC.

3620 Centennial Drive • Fort Wayne, IN 46808  
P.O. Box 80430 • Fort Wayne, IN 46898-0430

Phone: 888-THINBIT (888-844-6248) • (260) 484-3620  
Fax: 888-THINFAX (888-844-6329) • (260) 482-1881

Web: [www.thinbit.com](http://www.thinbit.com)  
General E-mail: [thinbit@kaisertool.com](mailto:thinbit@kaisertool.com)  
Orders: [orders@thinbit.com](mailto:orders@thinbit.com) Quotes: [quotes@thinbit.com](mailto:quotes@thinbit.com)

### GENERAL INFORMATION

- HOURS:** Our business hours are 7:30 am to 5:00 pm Eastern Standard Time. Processing for same day shipment stops at 3:00 pm EST.
- SHIPMENT:** Shipments are made by United Parcel Service. Ground service will be used (air for Alaska, Hawaii and U.S. Territories) unless otherwise specified by the customer. Shipments can be made via other carriers when customer provides shipping account number.
- TERMS:** Master Card, Visa, Discover, American Express and C.O.D. accepted. F.O.B. Fort Wayne, Indiana.  
No minimum order on standard items.  
We collect sales tax in California only.
- PRICING:** Current pricing is available online at: <http://www.thinbit.com/price list>. Items cannot be combined for quantity prices.  
A shipping and handling fee applies to all orders.  
Prices for tooling modifications will be given in writing.  
Pricing and availability on orders are confirmed to customer.
- RETURNS:** Returns are accepted for credit within 30 days of receipt of order and with prior written approval. All returns are subject to a 15% restocking charge. All returned goods must be in 'like-new' condition and returned in their original packaging.  
All claims for damaged goods or incorrect items must be made within 48 hours of receipt of order.
- CREDIT:** 30 day net credit for approved accounts.  
Accounts must re-establish credit after 18 months of inactivity.

### OUTSIDE THE U.S.A.

- TERMS:** Cash in advance until credit is established. Payment via Master Card, Visa, Discover, American Express, or bank to bank transfer in U.S. funds. F.O.B. Fort Wayne, Indiana, U.S.A.  
Please notify us prior to remittance to confirm total amount including shipping charges.  
Shipments made outside the U.S.A. are shipped via United Parcel Service.  
Shipments can be made via other carriers when customer provides shipping account number.

Kaiser Tool Company, Inc. has made every effort to produce a catalog that is accurate and error free. Kaiser Tool Company, Inc. is not responsible for any loss due to errors or changes in product specifications. For the most accurate and up to date information, contact our sales office.



To use this index: Match the first few characters from your invoice or tool to the 'Product Code'.

Product Code	Description	Page	Product Code	Description	Page
AD	Round & Square Adapters	7-2	LGTF	<b>GROOVE 'N TURN</b> ® Face Grooving Insert	2-10
AT	<b>MICROBIT</b> ® ACME Threading Tool	4-6	LGTT	<b>GROOVE 'N TURN</b> ® Threading Insert	4-10
BT	<b>MICROBIT</b> ® Boring Tool	3-4	LHA	<b>LITTLEBIT</b> ® Hardinge Toolholder	10-5
Clamp A	Clamp	10-5,6	LPT	<b>LITTLEBIT</b> ® Parting Insert	10-2
Clamp C	Clamp	Section 7, 10	LRE	<b>LITTLEBIT</b> ® Reversible Toolholder	10-7
Clamp M	Clamp	7-9	LREH	<b>LITTLEBIT</b> ® Reversible Head	10-7
Clamp N	Clamp	7-9	LRI	<b>LITTLEBIT</b> ® 90° Reversible Toolholder	10-7
Clamp Q	Clamp	7-12	LRIH	<b>LITTLEBIT</b> ® 90° Reversible Head	10-7
Clamp R	Clamp	7-12	LR0	<b>GROOVE 'N TURN</b> ® Round Internal Toolholder	7-8;10-8
Clamp X	Clamp	7-3,12	LROE	<b>GROOVE 'N TURN</b> ® Rnd Reversible Toolholder/Head	7-7;10-8
Clamp Y	Clamp	7-3,12	LSET	<b>LITTLEBIT</b> ® Grooving Insert Set	10-4
CN	Custom Made Tooling	Call	LSS	<b>LITTLEBIT</b> ® Swiss Toolholder	10-6
DGC	<b>DEEPGROOVE</b> ® Clamp	1-8,14;2-8,16;7-13,14	LSSFG	<b>GROOVE 'N TURN</b> ® Swiss Face Groove Toolholder	7-6;10-6
DGH	<b>DEEPGROOVE</b> ® Head	1-14;2-8,16;7-13,14	LTT	<b>LITTLEBIT</b> ® Threading Insert	10-3
DGI	<b>DEEPGROOVE</b> ® Insert	6-2	MBA	<b>MINI-BORE</b> ® Boring Bar	3-13
DGMI	<b>DEEPGROOVE</b> ® Insert	6-2	MBAI	<b>MINI-BORE</b> ® Insert	3-14
DGPA	<b>DEEPGROOVE</b> ® Tooling Package	2-16	MBB	<b>MINI-BORE</b> ® Boring Bar	3-15
DGPB	<b>DEEPGROOVE</b> ® Tooling Package	2-16	MBBI	<b>MINI-BORE</b> ® Insert	3-16
DGPC	<b>DEEPGROOVE</b> ® Tooling Package	2-16	MBC	<b>MINI-BORE</b> ® Boring Bar	3-17
DGPD	<b>DEEPGROOVE</b> ® Tooling Package	2-16	MBCI	<b>MINI-BORE</b> ® Insert	3-18
DGPE	<b>DEEPGROOVE</b> ® Tooling Package	1-14	MBE	<b>MINI-BORE</b> ® TRIGON® Boring Bar	3-8
DGPF	<b>DEEPGROOVE</b> ® Tooling Package	1-14	MBEI	<b>MINI-BORE</b> ® TRIGON® Insert	3-8
DGPG	<b>DEEPGROOVE</b> ® Tooling Package	1-14	MBF	<b>MINI-BORE</b> ® TRIGON® Boring Bar	3-9
DGPH	<b>DEEPGROOVE</b> ® Tooling Package	1-14	MBFI	<b>MINI-BORE</b> ® TRIGON® Insert	3-9
DGPM	<b>DEEPGROOVE</b> ® Tooling Package	2-8	MBG	<b>MINI-BORE</b> ® TRIGON® Boring Bar	3-10
DGPN	<b>DEEPGROOVE</b> ® Tooling Package	2-8	MBGI	<b>MINI-BORE</b> ® TRIGON® Insert	3-10
DGPO	<b>DEEPGROOVE</b> ® Tooling Package	7-13	MBZ	<b>MINI-BORE</b> ® Boring Bar	3-12
DGPP	<b>DEEPGROOVE</b> ® Tooling Package	7-13	MBZI	<b>MINI-BORE</b> ® Insert	3-12
DGPQ	<b>DEEPGROOVE</b> ® Tooling Package	7-13	MGC	<b>Mini GROOVE 'N TURN</b> ® Clamp	1-6;2-6
DGPR	<b>DEEPGROOVE</b> ® Tooling Package	7-13	MGT	<b>Mini GROOVE 'N TURN</b> ® ID Toolholder	1-6
DGPS	<b>DEEPGROOVE</b> ® Tooling Package	7-14	MGTF	<b>Mini GROOVE 'N TURN</b> ® Face Grooving Toolholder	2-6
DGPT	<b>DEEPGROOVE</b> ® Tooling Package	7-14	MGTI	<b>Mini GROOVE 'N TURN</b> ® Insert	1-5;2-5
DGPU	<b>DEEPGROOVE</b> ® Tooling Package	7-14	MGTT	<b>Mini GROOVE 'N TURN</b> ® Threading Insert	4-8
DGPV	<b>DEEPGROOVE</b> ® Tooling Package	7-14	PT	<b>MICROBIT</b> ® Profiling Tool	3-6
DGPZ	<b>DEEPGROOVE</b> ® Tooling Package	1-8	ROM	<b>LITTLEBIT</b> ® Multi-Insert Toolholder Round	7-10
DGS	<b>DEEPGROOVE</b> ® Shank	1-14;2-8,16;7-13,14	RROE	<b>GROOVE 'N TURN</b> ® Round Reversible Shank	7-7;10-8
DGT	<b>DEEPGROOVE</b> ® Shank	1-8	RS	<b>LITTLEBIT</b> ® Reversible Shank	10-7
EM	<b>FORM-A-GROOVE</b> ® Multi-Insert Toolholder	7-9	RT	<b>MICROBIT</b> ® Reverse Profiling Tool	3-6
ESM	<b>FORM-A-GROOVE</b> ® Multi-Insert Shank	7-9	S45	<b>LITTLEBIT</b> ® 45° Toolholder	10-9
FT	<b>MICROBIT</b> ® Face Grooving Tool	2-4	SFT	<b>LITTLEBIT</b> ® Flushtop Toolholder	10-5
GT	<b>MICROBIT</b> ® Grooving Tool	1-4	SGB	<b>LITTLEBIT</b> ® Insert Blank	10-4
HM	<b>LITTLEBIT</b> ® Multi-Insert Pocket	7-9	SGL	<b>LITTLEBIT</b> ® Grooving Insert	10-1
L36	<b>GROOVE 'N TURN</b> ® 30°/60° Toolholder	7-12	SGP	<b>LITTLEBIT</b> ® Parting Insert Blank	10-4
L45	<b>GROOVE 'N TURN</b> ® 45° Toolholder	7-12;10-9	SHA	<b>LITTLEBIT</b> ® Hardinge Toolholder	10-5
LFT	<b>LITTLEBIT</b> ® Flushtop Toolholder	10-5	SPT	<b>LITTLEBIT</b> ® Parting Insert	10-2
LGAT	<b>GROOVE 'N TURN</b> ® ACME Threading Insert	4-12	SRE	<b>LITTLEBIT</b> ® Reversible Toolholder	10-7
LGB	<b>LITTLEBIT</b> ® Insert Blank	10-4	SREH	<b>LITTLEBIT</b> ® Reversible Head	10-7
LGDT	<b>GROOVE 'N TURN</b> ® Dovetail Face Grooving Insert	2-12	SRI	<b>LITTLEBIT</b> ® 90° Reversible Toolholder	10-7
LGI	<b>LITTLEBIT</b> ® Grooving Insert	10-1	SRIH	<b>LITTLEBIT</b> ® 90° Reversible Head	10-7
LGOR	<b>GROOVE 'N TURN</b> ® Static O-Ring OD Insert	1-12	SR0	<b>LITTLEBIT</b> ® Round Internal Toolholder	10-8
LGORF	<b>GROOVE 'N TURN</b> ® Static O-Ring Face Insert	2-14	SROE	<b>LITTLEBIT</b> ® Round Reversible Toolholder/Head	10-8
LGP	<b>LITTLEBIT</b> ® Parting Insert Blank	10-4	SSET	<b>LITTLEBIT</b> ® Grooving Insert Set	10-4
LGPT	<b>GROOVE 'N TURN</b> ® Parting Insert	5-4	SSS	<b>LITTLEBIT</b> ® Swiss Toolholder	10-6
LGS	<b>GROOVE 'N TURN</b> ® OD Toolholder	7-3	SSSFG	<b>LITTLEBIT</b> ® Swiss Face Groove Toolholder	10-6
LGSF	<b>GROOVE 'N TURN</b> ® Face Grooving Toolholder	7-4	STT	<b>LITTLEBIT</b> ® Threading Insert	10-3
LGT45	<b>GROOVE 'N TURN</b> ® Chamfering Insert	4-14	TT	<b>MICROBIT</b> ® Threading Tool	4-4
LGT	<b>GROOVE 'N TURN</b> ® Grooving Insert	1-10;2-10			

## DISCONTINUED PRODUCT INDEX

### **PLEASE NOTE:**

The following products have been discontinued from our standard catalog. Stock delivery is limited to quantity on hand at time of order. For out of stock products, delivery will be determined at time of order.

Please call for any products on the discontinued list below. We may be able to substitute or design a special application.

To use this index: Match the first few characters from your invoice or tool to the **'Product Code'**

Product Code	Description	Product Code	Description
Clamp B	Clamp	MBBSQ	<b>MINI-BORE</b> ® Boring Bar
Clamp D	Clamp	MBCSQ	<b>MINI-BORE</b> ® Boring Bar
Clamp E	Clamp	MBCH4	<b>MINI-BORE</b> ® Boring Bar
Clamp G	Clamp	MBCS4	<b>MINI-BORE</b> ® Boring Bar
Clamp H	Clamp	MBP	<b>MINI-BORE</b> ® Coolant Adapter
Clamp I	Clamp	MMA	<b>MINI-BORE</b> ® Boring Bar
Clamp J	Clamp	MMB	<b>MINI-BORE</b> ® Boring Bar
Clamp L	Clamp	MSET	Mini <b>GROOVE 'N TURN</b> ® Insert Set
Clamp O	Clamp	SFG	<b>LITTLEBIT</b> ® Face Grooving Insert
Clamp P	Clamp	SME	<b>MINIBIT</b> ® External Toolholder
Clamp S	Clamp	SMF	<b>MINIBIT</b> ® Face Grooving Toolholder
Clamp T	Clamp	SMGI	<b>MINIBIT</b> ® Grooving Insert
EM34	<b>LITTLEBIT</b> ® Multi-Insert Toolholder	SMI	<b>MINIBIT</b> ® Internal Toolholder
ESM34	<b>LITTLEBIT</b> ® Multi-Insert Shank	SMSET	<b>MINIBIT</b> ® Insert Sets
GTSET	<b>GROOVE 'N TURN</b> ® Insert Set	SMSF	<b>MINIBIT</b> ® Shoulder Face Grooving Insert
HM34	<b>LITTLEBIT</b> ® Multi-Insert Pocket	SMSG	<b>MINIBIT</b> ® Shoulder Grooving Insert
LFG	<b>LITTLEBIT</b> ® Face Grooving Insert	SMTT	<b>MINIBIT</b> ® Threading Insert
LME	<b>MINIBIT</b> ® External Toolholder	SSF	<b>LITTLEBIT</b> ® Face Grooving Insert
LMF	<b>MINIBIT</b> ® Face Grooving Toolholder	SSG	<b>LITTLEBIT</b> ® Grooving Insert
LMGI	<b>MINIBIT</b> ® Grooving Insert	XFG	<b>LITTLEBIT</b> ® Face Grooving Insert
LMI	<b>MINIBIT</b> ® Internal Toolholder	XGB	<b>LITTLEBIT</b> ® Insert Blank
LMSET	<b>MINIBIT</b> ® Insert Sets	XGI	<b>LITTLEBIT</b> ® Grooving Insert
LMSF	<b>MINIBIT</b> ® Face Grooving Insert	XRE	<b>LITTLEBIT</b> ® Reversible Toolholder
LMSG	<b>MINIBIT</b> ® Shoulder Grooving Insert	XREH	<b>LITTLEBIT</b> ® Reversible Head
LMTT	<b>MINIBIT</b> ® Threading Insert	XRI	<b>LITTLEBIT</b> ® 90° Reversible Toolholder
LSF	<b>LITTLEBIT</b> ® Shoulder Face Grooving Insert	XRIH	<b>LITTLEBIT</b> ® 90° Reversible Head
LSG	<b>LITTLEBIT</b> ® Shoulder Grooving Insert	XR0	<b>LITTLEBIT</b> ® Round Internal Toolholder
MBBH4	<b>MINI-BORE</b> ® Boring Bar	XSET	<b>LITTLEBIT</b> ® Grooving Insert Set
MBBS4	<b>MINI-BORE</b> ® Boring Bar		









OVER 100,000 TOOLS IN STOCK FOR  
GROOVING • THREADING • PARTING • BORING  
TURNING • FACE GROOVING  
SPECIALS • FORM TOOLS

**KAISER TOOL COMPANY, INC.**

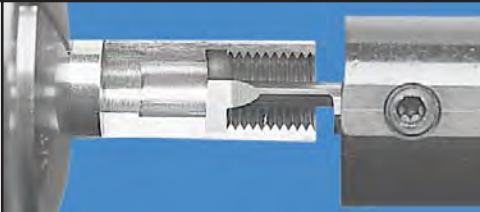
Phone: 888-THINBIT (888-844-6248) or (260) 484-3620 • Fax: 888-THINFAX (888-844-6329) or (260) 482-1881  
www.thinbit.com • General E-mail: [thinbit@kaisertool.com](mailto:thinbit@kaisertool.com) • Orders: [orders@thinbit.com](mailto:orders@thinbit.com) • Quotes: [quotes@thinbit.com](mailto:quotes@thinbit.com)

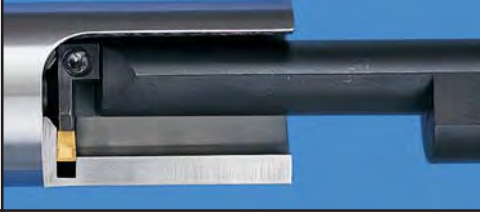
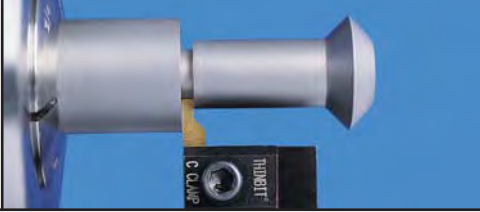
## PRODUCT SELECTION GUIDE - GROOVING

# GROOVING

PAGE 1-3		<ul style="list-style-type: none"> <li>• For internal diameters of .125" and larger</li> <li>• Groove widths .004"-.250"</li> <li>• For depth of cut up to .150"</li> <li>• Solid carbide shanks in 1/8", 3/16", 1/4", 5/16", 3/8" and 1/2" diameter</li> </ul>
PAGE 1-5		<ul style="list-style-type: none"> <li>• For internal diameters of .325" and larger</li> <li>• Groove widths .004"-.125"</li> <li>• For depth of cut up to .125"</li> <li>• Inserts can groove, bore and generate profiles</li> <li>• Inserts can also be used for face grooving</li> </ul>
PAGE 1-7		<ul style="list-style-type: none"> <li>• For internal diameters of 1" and larger</li> <li>• Groove widths 2, 3 and 4mm</li> <li>• For depth of cut up to .500"</li> </ul>
PAGE 1-9		<ul style="list-style-type: none"> <li>• Groove widths .004"-.150"</li> <li>• For depth of cut 2-1/2 to 3 times width</li> <li>• Inserts can groove, turn, generate profiles and be used for face grooving over 3" diameters</li> <li>• Carbide and High Speed Steel</li> </ul>
PAGE 1-11		<ul style="list-style-type: none"> <li>• Groove widths .095", .125" &amp; .142"</li> <li>• Included Angle 7°</li> <li>• Two grades of Sub-Micron Grain Carbide</li> </ul>
PAGE 1-13		<ul style="list-style-type: none"> <li>• Groove widths 2, 3, 4, 5 and 6mm</li> <li>• For depth of cut to 1"</li> <li>• Inserts can also be used for parting and face grooving</li> </ul>
PAGE 8-7		<div style="text-align: center;">  <p>Used for generating multiple groove forms simultaneously</p> </div>



Scan this code for additional information.

[www.thinbit.com/qr1-1](http://www.thinbit.com/qr1-1)

### KAISER TOOL COMPANY, INC.

Phone: 888-THINBIT (888-844-6248) or (260) 484-3620 • Fax: 888-THINFAX (888-844-6329) or (260) 482-1881  
[www.thinbit.com](http://www.thinbit.com) • General E-mail: [thinbit@kaisertool.com](mailto:thinbit@kaisertool.com) • Orders: [orders@thinbit.com](mailto:orders@thinbit.com) • Quotes: [quotes@thinbit.com](mailto:quotes@thinbit.com)



# TOOLING ORIENTATION GUIDE - GROOVING

# GROOVING

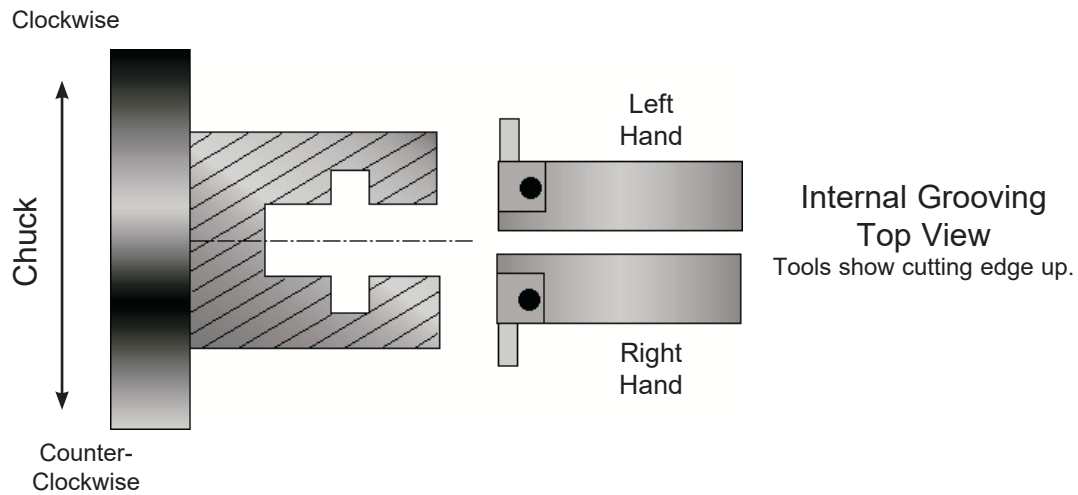
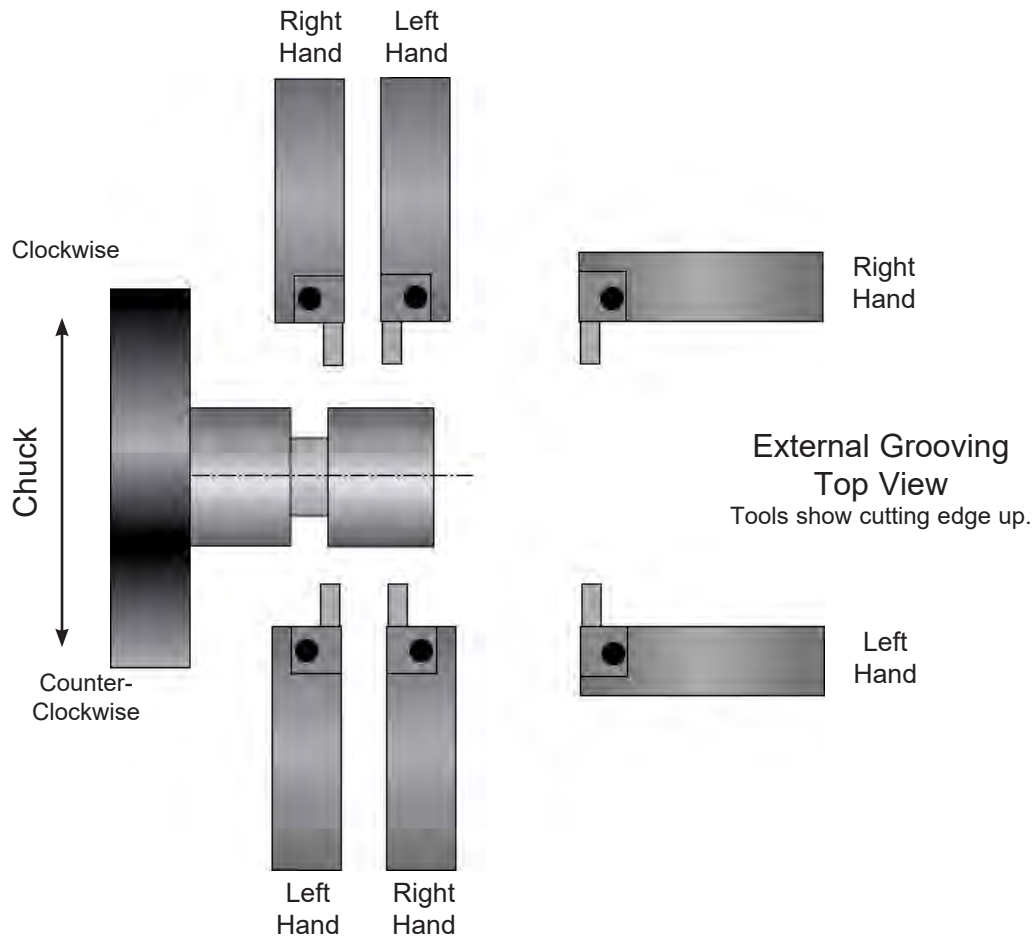

## KAISER TOOL COMPANY, INC.

# MICROBIT®

## PRODUCT INFORMATION

- Internal grooving for diameters .125" and larger.
- .004" through .250" groove widths in .001" increments.
- 1/8", 3/16", 1/4", 5/16", 3/8" and 1/2" shanks.
- Sub-micron grain **DURA-MAX® 2000** Carbide.
- Tools available with TiN, TiAlN, TiCN and diamond coating.
- Short neck lengths for greater rigidity; long neck lengths for greater reach.
- Elliptically ground necks for greater strength.

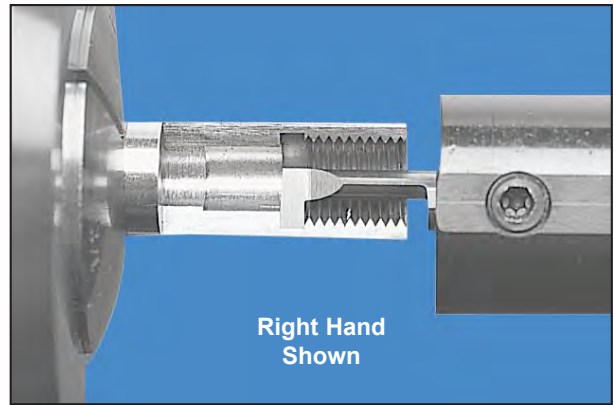

## MODIFICATIONS

SEE PAGE  
**8-3**  
FOR ADDITIONAL  
INFORMATION

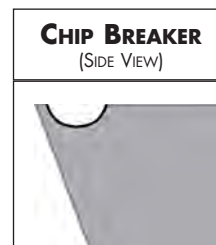
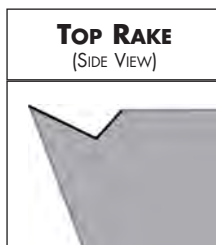
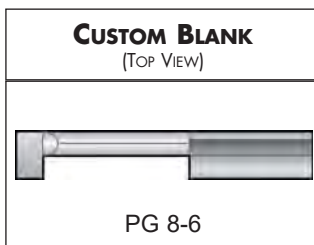
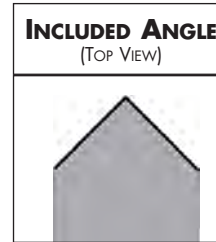
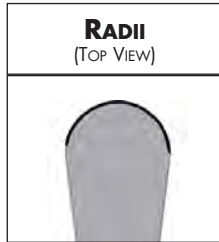

## TOOLHOLDER SELECTIONS

### ADAPTER STYLES

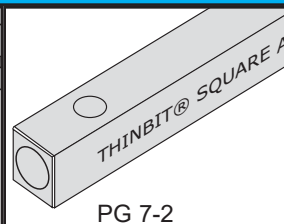
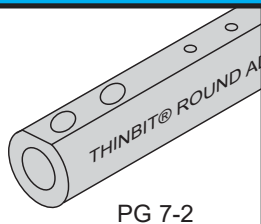

## TECHNICAL SECTIONS

### PRODUCT DEMONSTRATION



[www.thinbit.com/qr1-3](http://www.thinbit.com/qr1-3)

### SPEEDS AND FEEDS

PG 9-10

### APPLICATION REFERENCE

PG 9-4

### TROUBLESHOOTING

PG 9-7

## KAISER TOOL COMPANY, INC.

Phone: 888-THINBIT (888-844-6248) or (260) 484-3620 • Fax: 888-THINFAX (888-844-6329) or (260) 482-1881  
www.thinbit.com • General E-mail: [thinbit@kaisertool.com](mailto:thinbit@kaisertool.com) • Orders: [orders@thinbit.com](mailto:orders@thinbit.com) • Quotes: [quotes@thinbit.com](mailto:quotes@thinbit.com)

# I.D. GROOVING TOOLS

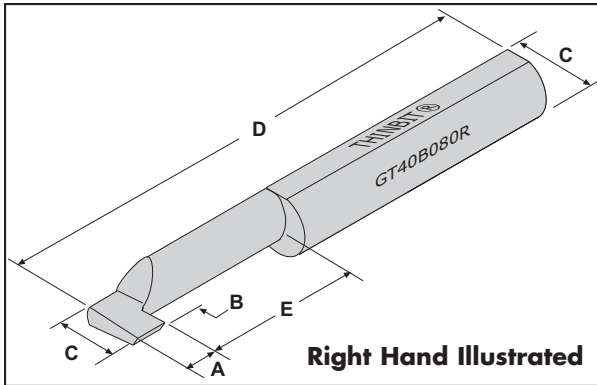

FRONT RAKE: Primary 21°  
 BACK CLEARANCE: 2°  
 SIDE CLEARANCE: 2°  
 RADIUS: Sharp corner through full radius available  
 TOP RAKE: 0°  
 LEAD ANGLE: 0°  
 'A' TOLERANCE: .004" - .250": +.0009"/-.0000"

I.D. GROOVING

## ORDERING INSTRUCTIONS

Complete the **ORDER CODE** in the table below that represents your selection of groove width and tool dimensions.

**EXAMPLE:**

The **ORDER CODE** for a 1/4" shank, right hand tool with an .080" tool width, .110" depth of cut and .500" long neck is:

**GT40B 0 8 0 R**

Specify the Tool Width 'A'  ↑

SPECIFICATIONS				ORDER CODE				INFORMATION											
Minimum Bore & Shank Diameter  'C'	Tool Width Range  'A'	Depth of Cut  'B'	Neck Length  'E'	DURA-MAX® 2000 Carbide See Page 9-10 for speeds and feeds		Add-ons Use 'Order Code' and Add			Overall Length  'D'	Toolholder Page 7-2  Use Toolholders Beginning With									
				Right Hand	Left Hand	Full Radius Page 8-3	Corner Radius Page 8-3	Coating Page 9-6											
1/8"	.004"-.063"	.004"-.006" = 3 x 'A'	.250"	GT20C ___ R	GT20C ___ L	Maximum radius limited to depth of cut  * See Note	add 'FR'	(indicate size in .xxx")  Maximum radius limited to depth of cut  * See Note	1.365" + 'A'	'AD'									
		.007"-.063" = .020"	.375"	GT21C ___ R	GT21C ___ L														
		.004"-.016" = 3 x 'A'	.250"	GT20B ___ R	GT20B ___ L														
		.017"-.063" = .050"	.375"	GT21B ___ R	GT21B ___ L														
3/16"	.004"-.093"	.004"-.011" = 3 x 'A'	.375"	GT30C ___ R	GT30C ___ L				Maximum radius limited to depth of cut  * See Note	add 'CR ___'	TiN add 'C'  TiCN add 'D'  TiAlN add 'E'  Diamond add 'F'	1.865" + 'A'	'AD'						
		.012"-.093" = .035"	.625"	GT31C ___ R	GT31C ___ L														
		.004"-.026" = 3 x 'A'	.375"	GT30B ___ R	GT30B ___ L														
		.027"-.093" = .080"	.625"	GT31B ___ R	GT31B ___ L														
1/4"	.004"-.125"	.004"-.016" = 3 x 'A'	.500"	GT40C ___ R	GT40C ___ L							Maximum radius limited to depth of cut  * See Note	add 'FR'	(indicate size in .xxx")  Maximum radius limited to depth of cut  * See Note	2.365" + 'A'	'AD'			
		.017"-.125" = .050"	.750"	GT41C ___ R	GT41C ___ L														
		.004"-.036" = 3 x 'A'	.500"	GT40B ___ R	GT40B ___ L														
		.037"-.125" = .110"	.750"	GT41B ___ R	GT41B ___ L														
5/16"	.004"-.156"	.004"-.021" = 3 x 'A'	.625"	GT50C ___ R	GT50C ___ L	Maximum radius limited to depth of cut  * See Note	add 'FR'	(indicate size in .xxx")  Maximum radius limited to depth of cut  * See Note							2.330" + 'A'	'AD'			
		.022"-.156" = .063"	1.000"	GT51C ___ R	GT51C ___ L														
		.004"-.046" = 3 x 'A'	.625"	GT50B ___ R	GT50B ___ L														
		.047"-.156" = .140"	1.000"	GT51B ___ R	GT51B ___ L														
3/8"	.004"-.187"	.004"-.036" = 3 x 'A'	.750"	GT60C ___ R	GT60C ___ L				Maximum radius limited to depth of cut  * See Note	add 'FR'	(indicate size in .xxx")  Maximum radius limited to depth of cut  * See Note				2.800" + 'A'	'AD'			
		.037"-.187" = .110"	1.250"	GT61C ___ R	GT61C ___ L														
1/2"	.004"-.250"	.004"-.050" = 3 x 'A'	1.000"	GT80C ___ R	GT80C ___ L										Maximum radius limited to depth of cut  * See Note	add 'FR'	(indicate size in .xxx")  Maximum radius limited to depth of cut  * See Note	3.240" + 'A'	'AD'
		.051"-.250" = .150"	1.750"	GT81C ___ R	GT81C ___ L														

\* Example: GT31C093R - max radius would be .035"

## KAISER TOOL COMPANY, INC.

Phone: 888-THINBIT (888-844-6248) or (260) 484-3620 • Fax: 888-THINFAX (888-844-6329) or (260) 482-1881  
 www.thinbit.com • General E-mail: thinbit@kaisertool.com • Orders: orders@thinbit.com • Quotes: quotes@thinbit.com



## PRODUCT INFORMATION

- Internal grooving and profiling for diameters .325" and larger.
- Shank sizes 1/4", 3/8", 1/2" and 5/8" in steel, heavy metal or carbide.
- All toolholders are reversible for right and left hand orientation.
- Sub-micron grain **DURA-MAX® 2000** and **5000** Carbides and High Speed Steel.
- Modifications can be provided on any of our tooling.
- Please contact us with your application requirements.



Left Hand Insert in Right Hand Toolholder Shown

## TECHNICAL SECTIONS

### PRODUCT DEMONSTRATION



[www.thinbit.com/gr1-5](http://www.thinbit.com/gr1-5)

### SPEEDS AND FEEDS

PG 9-10

### APPLICATION REFERENCE

PG 9-4

### TROUBLESHOOTING

PG 9-7

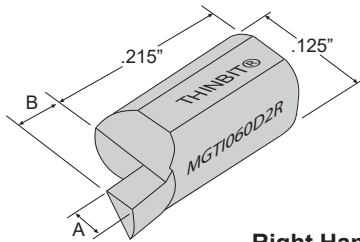

Right Hand Illustrated

FRONT RAKE: 15°  
 BACK CLEARANCE: 2° both sides  
 SIDE CLEARANCE: 2° I.D. side  
 RADIUS: Sharp corner through  
           full radius available  
 TOP RAKE: 0°  
 LEAD ANGLE: 0°  
 'A' TOLERANCE:  
 .004" - .063": +.0009"/-.0000"  
 .064" - .125": +.001"/-.001"

## SPECIFICATIONS

## ORDER CODE

Insert Orientation	Insert Width  'A'	Depth of Cut  'B'	Insert Grades		Add-ons Use 'Order Code' and Add		
			DURA-MAX® 2000 Carbide For Steel & Interrupted Cutting	DURA-MAX® 5000 Carbide For Aluminum & Non-ferrous	Full Radius Page 8-3	Corner Radius Page 8-3	Coating Page 9-6
Right Hand  For ID grooving use left hand 'MGT' Page 1-5  For face grooving use right hand 'MGTF' Page 2-6	.004"-.063"	<u>Width</u> <u>DOC</u> .004"-.031" = 2 x 'A' .032"-.063" = .063"	MGTI ___ _D2R	MGTI ___ _D5R	add 'FR'	(indicate size in .xxx")	TiN add 'C'  TiCN add 'D'  TiAlN add 'E'  Diamond add 'F'
	.064"-.125"	<u>Width</u> <u>DOC</u> .064"-.083" = 1.5 x 'A' .084"-.125" = .125"					
Left Hand  For ID grooving use right hand 'MGT' Page 1-5  For face grooving use left hand 'MGTF' Page 2-6	.004"-.063"	<u>Width</u> <u>DOC</u> .004"-.031" = 2 x 'A' .032"-.063" = .063"	MGTI ___ _D2L	MGTI ___ _D5L			
	.064"-.125"	<u>Width</u> <u>DOC</u> .064"-.083" = 1.5 x 'A' .084"-.125" = .125"					

## KAISER TOOL COMPANY, INC.

# I.D. GROOVING TOOLS

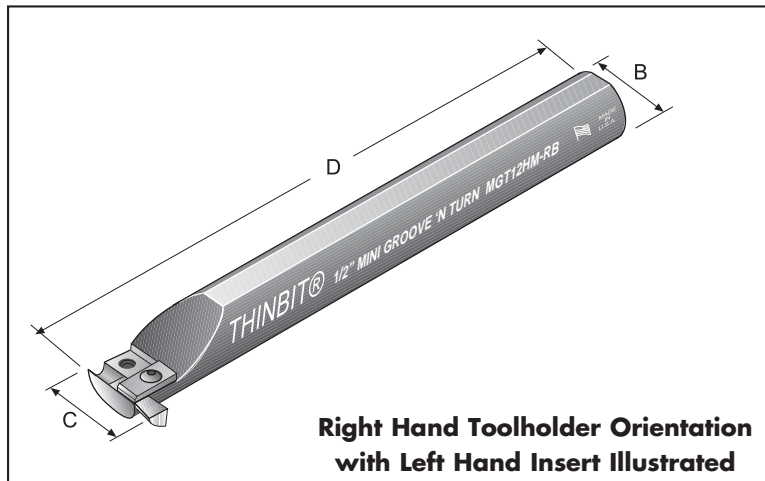

Note:

- All toolholders are reversible for right hand or left hand orientation.

- For grooving:

Insert Width	Depth of Cut
.004"-.031"	2 x width
.032"-.063"	.063"
.064"-.083"	1.5 x width
.084"-.125"	.125"

I.D. GROOVING

## ORDERING INSTRUCTIONS

Select the **ORDER CODE** in the table below that represents your selection of tool specifications.

**EXAMPLE:**

The **ORDER CODE** for a .575" minimum bore toolholder with a 1/2" steel shank is:

**MGT12**

SPECIFICATIONS		ORDER CODE				INFORMATION		
Minimum Bore  'C'	Toolholder Material  Extension Ratios: Steel: 4x Heavy Metal: 6x Carbide: 8x	Toolholder Package  Includes Shank, Clamp and Hardware	Replacement Parts Clamp Only   Screw Only   Wrench Only			Overall Length  'D'	Shank Diameter  'B'	Inserts  Use Inserts Beginning With
.325" .063" Insert Width Maximum (Threading & Groove Widths .004"-.063")	Steel	MGT14	MGC1	F31	W31	4.000"	1/4"	Grooving: 'MGT1' Page 1-5  Threading: 'MGTT' Page 4-8  Use right hand inserts for clockwise or left hand inserts for counter-clockwise
	Heavy Metal	MGT14HM				3.965"		
	Carbide	MGT14C				6.504"		
.450" .063" Insert Width Maximum (Threading & Groove Widths .004"-.063")	Steel	MGT38	MGC1	F31	W31	5.500"	3/8"	
	Heavy Metal	MGT38HM				5.485"		
	Carbide	MGT38C				6.768"		
.575" (Threading & Groove Widths .004"-.063") or .640" (Groove Widths .064"-.125")	Steel	MGT12	MGC1	F31	W31	5.500"	1/2"	
	Heavy Metal	MGT12HM				5.485"		
.690" (Threading & Groove Widths .004"-.063") or .755" (Groove Widths .064"-.125")	Steel	MGT58	MGC1	F31	W31	5.500"	5/8"	

## KAISER TOOL COMPANY, INC.

Phone: 888-THINBIT (888-844-6248) or (260) 484-3620 • Fax: 888-THINFAX (888-844-6329) or (260) 482-1881  
www.thinbit.com • General E-mail: thinbit@kaisertool.com • Orders: orders@thinbit.com • Quotes: quotes@thinbit.com

## PRODUCT INFORMATION

- Internal grooving for diameters 1" and larger.
- 3/4" and 1" shank diameters.
- Right hand orientation standard.
- Short neck lengths for greater rigidity; long neck lengths for greater reach.
- Elliptical neck for increased strength and rigidity.
- Modifications can be provided on any of our tooling. Please contact us with your application requirements.

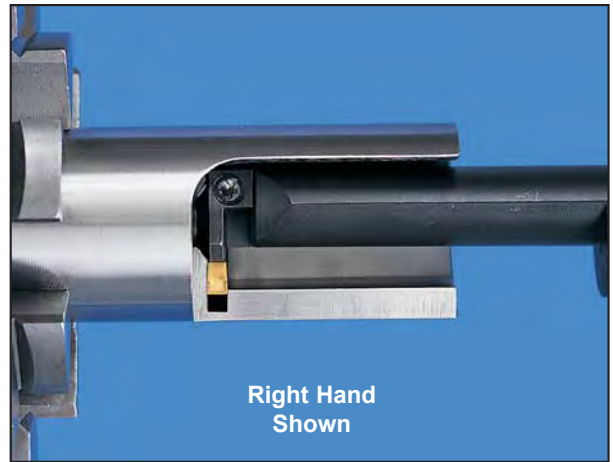

## INSERT STYLES

**INSERT SELECTIONS**  
SEE PAGE 6-1

**CORNER RADIUS**  
(TOP VIEW)



**SHARP CORNER**  
(TOP VIEW)



## PRODUCT DEMONSTRATION



[www.thinbit.com/qr1-7](http://www.thinbit.com/qr1-7)

## SPEEDS AND FEEDS

PG 9-10

## APPLICATION REFERENCE

PG 9-4

## TROUBLESHOOTING

PG 9-7

**TECHNICAL SECTIONS**

## KAISER TOOL COMPANY, INC.

Phone: 888-THINBIT (888-844-6248) or (260) 484-3620 • Fax: 888-THINFAX (888-844-6329) or (260) 482-1881  
www.thinbit.com • General E-mail: [thinbit@kaisertool.com](mailto:thinbit@kaisertool.com) • Orders: [orders@thinbit.com](mailto:orders@thinbit.com) • Quotes: [quotes@thinbit.com](mailto:quotes@thinbit.com)



# I.D. GROOVING TOOLS

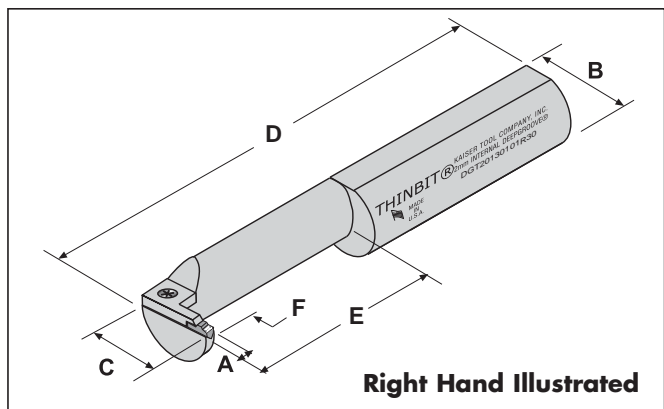

## ORDERING INSTRUCTIONS

Select the **ORDER CODE** in the table below that represents your selection of tool specifications.

**EXAMPLE:**

The **ORDER CODE** for a 2mm insert width toolholder package with a depth of cut of .500", a 1" shank and a 3" neck is: **DGPZ2013010130**

SPECIFICATIONS					ORDER CODE						INFO.					
Minimum Bore	Insert Width	Depth of Cut	Neck Length	Shank Diameter	Toolholder Package Includes Shank, Clamp and Hardware	Inserts	Replacement Parts				Overall Length					
'C'	'A'	'F'	'E'	'B'	Right Hand	Use Inserts Beginning With	Shank	Clamp	Screw	Wrench	'D'					
1"	2mm (.078")	.393"	1.5"	3/4"	DGPZ2010013415	'DGI2' (Page 6-2)	DGT20100134R15	DGC82013	S4552	W3200	5.5"					
			1"	DGPZ2010010115	DGT20100101R15											
		3"	3/4"	DGPZ2010013430	DGT20100134R30		7"									
			1"	DGPZ2010010130	DGT20100101R30											
		.500"	1.5"	3/4"	DGPZ2013013415		DGT20130134R15					5.5"				
			1"	DGPZ2013010115	DGT20130101R15											
	3"	3/4"	DGPZ2013013430	DGT20130134R30	7"											
		1"	DGPZ2013010130	DGT20130101R30												
	1"	3mm (.118")	.393"	1.5"	3/4"		DGPZ3010013415				'DGM13' (Page 6-2)	DGT30100134R15	DGC83013	S4552	W3200	5.5"
				1"	DGPZ3010010115		DGT30100101R15									
			3"	3/4"	DGPZ3010013430		DGT30100134R30					7"				
				1"	DGPZ3010010130		DGT30100101R30									
.500"			1.5"	3/4"	DGPZ3013013415	DGT30130134R15	5.5"									
			1"	DGPZ3013010115	DGT30130101R15											
3"		3/4"	DGPZ3013013430	DGT30130134R30	7"											
		1"	DGPZ3013010130	DGT30130101R30												
1"		4mm (.157")	.393"	1.5"	3/4"	DGPZ4010013415	'DGM14' (Page 6-2)	DGT40100134R15	DGC84013	S4552		W3200				5.5"
				1"	DGPZ4010010115	DGT40100101R15										
			3"	3/4"	DGPZ4010013430	DGT40100134R30		7"								
				1"	DGPZ4010010130	DGT40100101R30										
	.500"		1.5"	3/4"	DGPZ4013013415	DGT40130134R15		5.5"								
			1"	DGPZ4013010115	DGT40130101R15											
	3"	3/4"	DGPZ4013013430	DGT40130134R30	7"											
		1"	DGPZ4013010130	DGT40130101R30												

### KAISER TOOL COMPANY, INC.

## PRODUCT INFORMATION

- External grooving and turning.
- Internal grooving and boring with 1.250" minimum bore diameter.
- .004" through .150" in .001" increments available.
- Sub-micron grain **DURA-MAX® 2000** and **5000** Carbides and High Speed Steel.
- Inserts available with TiN, TiAlN, TiCN and Diamond coating.

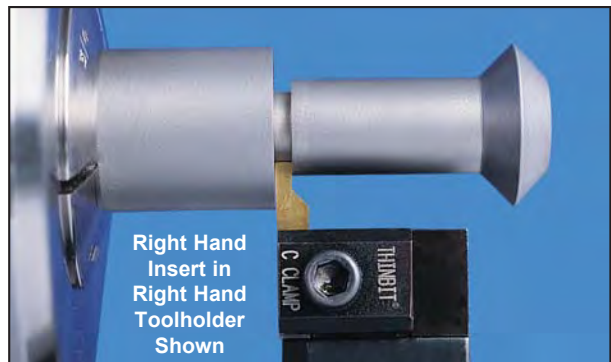

## MODIFICATIONS

SEE PAGE 8-3 FOR ADDITIONAL INFORMATION

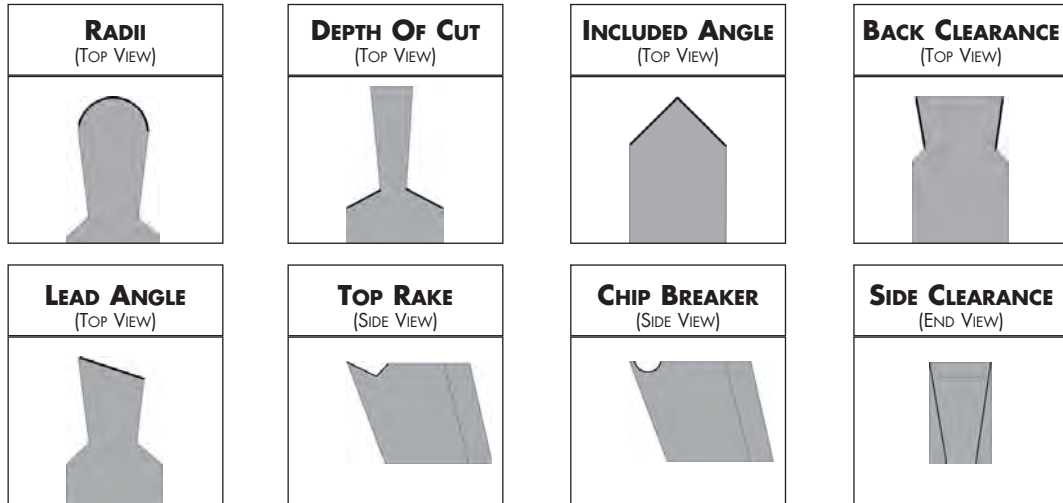

## TOOLHOLDER SELECTIONS

### CNC, SWISS, CONVENTIONAL STYLE

### ROUND STYLE

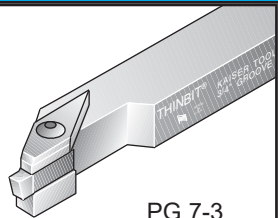

PG 7-3

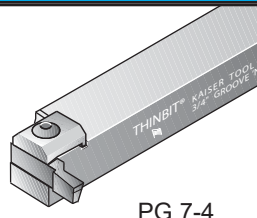

PG 7-4

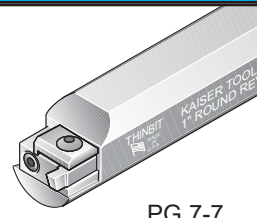

PG 7-7

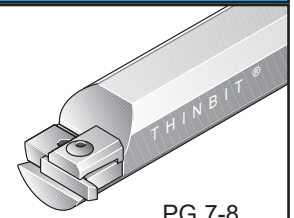

PG 7-8

## TECHNICAL SECTIONS

### PRODUCT DEMONSTRATION



[www.thinbit.com/qr1-9](http://www.thinbit.com/qr1-9)

### SPEEDS AND FEEDS

PG 9-10

### APPLICATION REFERENCE

PG 9-3

### TROUBLESHOOTING

PG 9-7

## KAISER TOOL COMPANY, INC.

Phone: 888-THINBIT (888-844-6248) or (260) 484-3620 • Fax: 888-THINFAX (888-844-6329) or (260) 482-1881  
[www.thinbit.com](http://www.thinbit.com) • General E-mail: [thinbit@kaisertool.com](mailto:thinbit@kaisertool.com) • Orders: [orders@thinbit.com](mailto:orders@thinbit.com) • Quotes: [quotes@thinbit.com](mailto:quotes@thinbit.com)

# O.D./I.D. GROOVING AND TURNING INSERTS

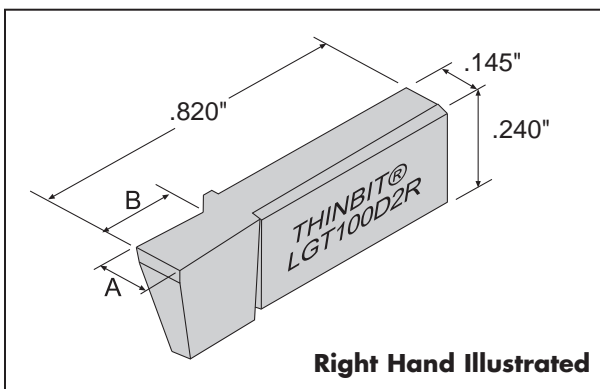

**FRONT RAKE:**

CARBIDE: Primary 10° honed, Secondary 15°  
HIGH SPEED STEEL: 15°

**BACK CLEARANCE:** 2-1/2° both sides

**SIDE CLEARANCE:** .004" - .019" - 0° both sides  
.020" - .150" - 5° both sides

**RADIUS:** Sharp corner through full radius available

**TOP RAKE:** 0°

**LEAD ANGLE:** 0°

**NOTES:** Capable of grooving along a shoulder  
.004"-.019" inserts are not designed for turning

## ORDERING INSTRUCTIONS

Complete the **ORDER CODE** in the table below that represents your selection of groove width and insert grade.

**EXAMPLE:**

The **ORDER CODE** for a right hand, .100" insert width in **DURA-MAX® 2000** is:  
**LGT 1 0 0 D2 R**

Specify the Tool Width 'A' \_\_\_\_\_ ↑

SPECIFICATIONS			ORDER CODE					INFO.	
Insert Orientation	Insert Width  'A'  +.0009"/-.0000"	Depth of Cut  'B'	Insert Grades <small>See Page 9-5 for expanded material descriptions and Page 9-10 for Speeds and Feeds information</small>			Add-ons <small>Use 'Order Code' and Add</small>			Toolholder Catalog Section 7  Use Toolholders Beginning With
			DURA-MAX® 2000 Carbide <small>For Steel &amp; Interrupted Cutting</small>	DURA-MAX® 5000 Carbide <small>For Aluminum &amp; Non-ferrous</small>	High Speed Steel	Full Radius Page 8-3	Corner Radius Page 8-3	Coating Page 9-6	
Right Hand	.004"-.150"	<small>Width DOC</small> .004"-.033" = 3 x 'A' .034"-.039" = .100" .040"-.100" = 2.5 x 'A' .101"-.150" = .250"	LGT ___ D2R	LGT ___ D5R	LGT ___ HSR	add 'FR'	add 'CR___' <small>(indicate size in .xxx")</small>	TiN add 'C'  TiCN add 'D'	'L'  Use right hand straight holder or left hand 90° holder
Left Hand	.004"-.150"		LGT ___ D2L	LGT ___ D5L	LGT ___ HSL	add 'FR'	add 'CR___' <small>(indicate size in .xxx")</small>	TiAIN add 'E'  Diamond add 'F'	'L'  Use left hand straight holder or right hand 90° holder

### KAISER TOOL COMPANY, INC.



## PRODUCT INFORMATION

- External grooving.
- Internal Static O-Ring grooving with 1.250" minimum bore diameter.
- Sub-micron grain **DURA-MAX® 2000** and **5000** Carbides.
- Inserts available with TiN, TiAlN, TiCN and Diamond coating.

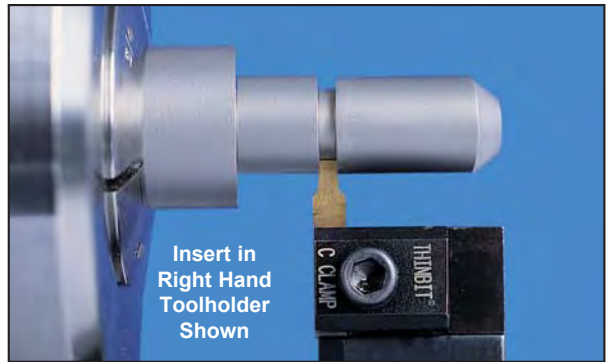

## MODIFICATIONS

SEE PAGE  
8-3  
FOR ADDITIONAL  
INFORMATION

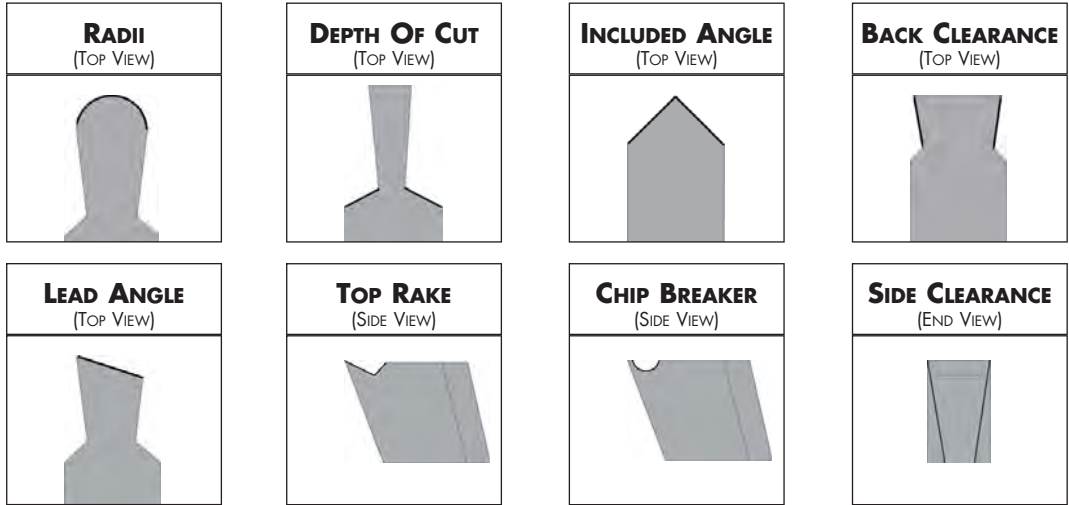

## TOOLHOLDER SELECTIONS

### CNC, SWISS, CONVENTIONAL STYLE

### ROUND STYLE

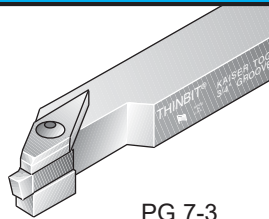

PG 7-3

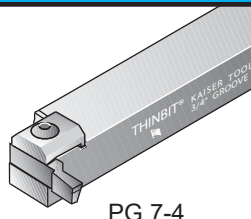

PG 7-4

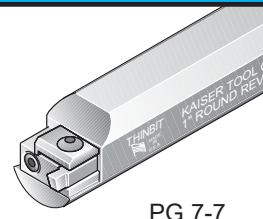

PG 7-7

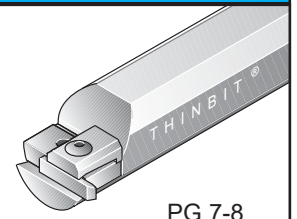

PG 7-8

## TECHNICAL SECTIONS

### PRODUCT DEMONSTRATION



[www.thinbit.com/qr1-11](http://www.thinbit.com/qr1-11)

### SPEEDS AND FEEDS

PG 9-10

### APPLICATION REFERENCE

PG 9-3

### TROUBLESHOOTING

PG 9-7

## KAISER TOOL COMPANY, INC.

# O.D. STATIC O-RING INSERTS

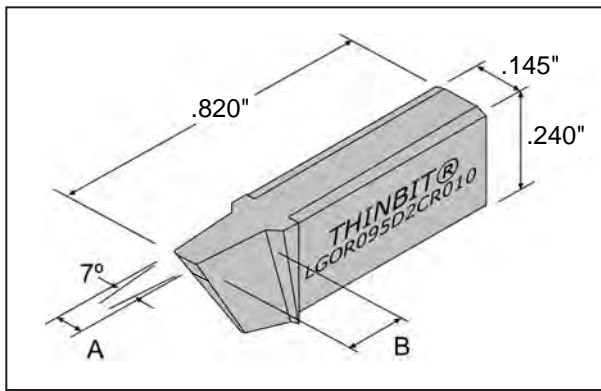

FRONT RAKE: Primary 10° honed, Secondary 15°  
 BACK CLEARANCE: 7° included angle  
 SIDE CLEARANCE: 5° both sides  
 RADIUS: .010" or .020"  
 TOP RAKE: 0°  
 LEAD ANGLE: 0°  
 DEPTH OF CUT: .200" or .250"

STATIC O-RING GROOVING

## ORDERING INSTRUCTIONS

Select the **ORDER CODE** in the table below that represents your selection of groove width and insert grade.

**EXAMPLE:**

The **ORDER CODE** for a .095" insert width in **DURA-MAX® 2000** is:

**LGOR095D2CR010**

SPECIFICATIONS			ORDER CODE		INFO.	
Insert Orientation & Radius	Insert Width	Depth of Cut	Insert Grades See Page 9-5 for expanded material descriptions and Page 9-10 for Speeds and Feeds information		Add-ons Use 'Order Code' and Add	Toolholder Catalog Section 7  Use Toolholders Beginning With
	'A' ± .001"	'B'	DURA-MAX® 2000 Carbide For Steel & Interrupted Cutting	DURA-MAX® 5000 Carbide For Aluminum & Non-ferrous	Coating Page 9-6	
Centered .010" Corner Radius	.095"	.250"	LGOR095D2CR010	LGOR095D5CR010	TiN add 'C'	'L'
	.142"	.200"	LGOR142D2CR010	LGOR142D5CR010	TiCN add 'D' TiAlN add 'E'	
Centered .020" Corner Radius	.125"	.250"	LGOR125D2CR020	LGOR125D5CR020	Diamond add 'F'	

## KAISER TOOL COMPANY, INC.

## PRODUCT INFORMATION

- External grooving and parting with depth of cut to 1".
- Shank sizes 3/4", 1", 16mm, 20mm and 25mm in straight and 90° orientations.
- Modular tooling system will also accept face grooving heads. See compatibility guide on Page 9-8.
- If round shanks are required, see Page 7-13, Package Styles 'Q' and 'R'.
- Modifications can be provided on any of our tooling. Please contact us with your application requirements.

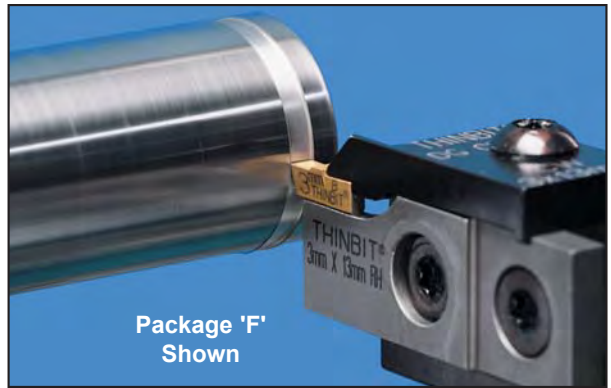

## INSERT SELECTIONS

SEE PAGE 6-1

### INSERT STYLES

#### CORNER RADIUS (TOP VIEW)



#### SHARP CORNER (TOP VIEW)



## TECHNICAL SECTIONS

### PRODUCT DEMONSTRATION



[www.thinbit.com/qr1-13](http://www.thinbit.com/qr1-13)

### SPEEDS AND FEEDS

PG 9-10

### APPLICATION REFERENCE

PG 9-3

### TROUBLESHOOTING

PG 9-7

### PACKAGE STYLE

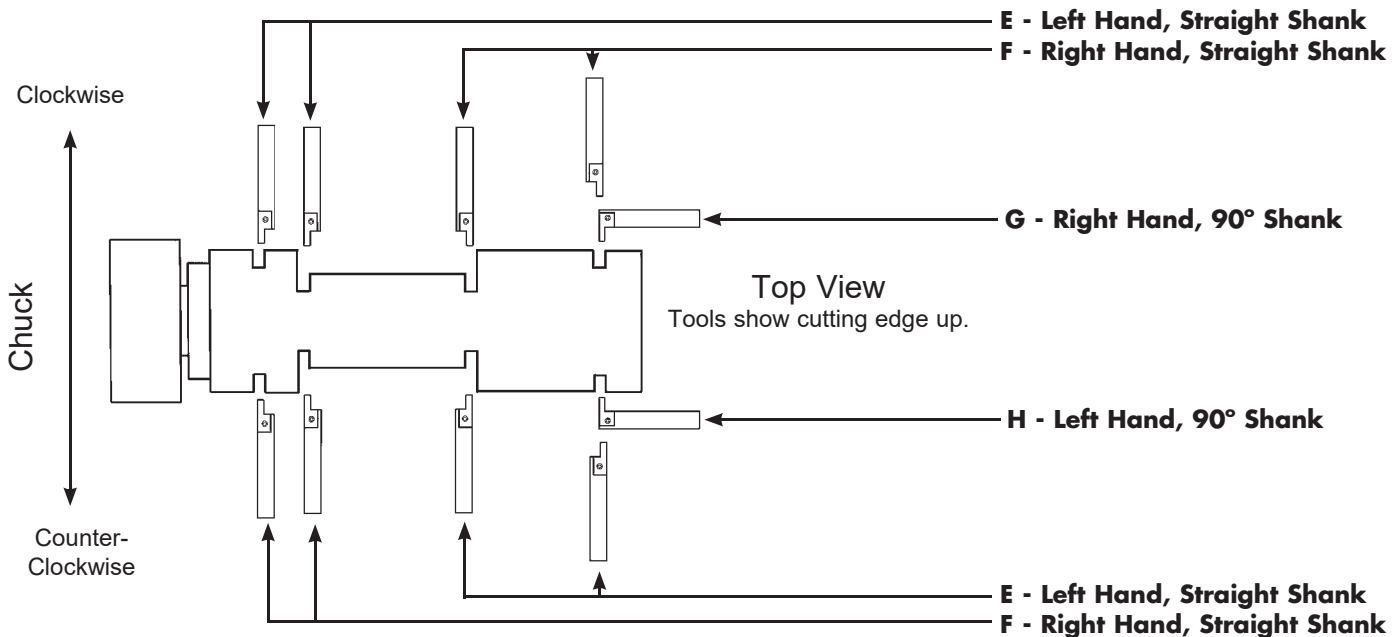

Note: If round shanks are required, see Page 7-13, Package Styles 'Q' and 'R'.

## KAISER TOOL COMPANY, INC.

Phone: 888-THINBIT (888-844-6248) or (260) 484-3620 • Fax: 888-THINFAX (888-844-6329) or (260) 482-1881  
[www.thinbit.com](http://www.thinbit.com) • General E-mail: [thinbit@kaisertool.com](mailto:thinbit@kaisertool.com) • Orders: [orders@thinbit.com](mailto:orders@thinbit.com) • Quotes: [quotes@thinbit.com](mailto:quotes@thinbit.com)



# O.D. GROOVING AND PARTING TOOLS

## ORDERING INSTRUCTIONS

### 3/4" and 1" Shanks

Select the **ORDER CODE** in the table below that represents your selection of tool specifications.

**EXAMPLE:**

The **ORDER CODE** for a 3mm insert width, toolholder package style 'E' with a .500" depth of cut and 1" shank is:

**DGPE301301**

### Metric Shanks

Complete the **ORDER CODE** in the table below with the shank size as 16 (16mm), 20 (20mm) or 25 (25mm).

**EXAMPLE:**

The **ORDER CODE** for a 3mm insert width, toolholder package style 'E' with a .500" depth of cut and 20mm shank is:

**DGPE3013 20** ← Specify the 'SHANK SIZE'

O.D. GROOVING & PARTING







SPECIFICATIONS			ORDER CODE								
Insert Width	Depth of Cut	Package Style  See Page 1-13	Toolholder Package <small>Includes Shank, Head, Clamp and Hardware</small>			Inserts  Use Inserts Beginning With	Head	Replacement Parts			
			3/4" Shank <small>3/4"x3/4"x5"</small>	1" Shank <small>1"x1"x5"</small>	Metric Shanks <small>16 = 16x16x125mm 20 = 20x1"x125mm 25 = 25x1"x125mm</small>			Head Hardware	Shank <small>34 = 3/4" 01 = 1" 16 = 16mm 20 = 20mm 25 = 25mm</small>	Clamp	Clamp Hardware
2mm (.078")	13mm (1/2")	E	DGPE201334	DGPE201301	DGPE2013 __	'DGI2'  (Page 6-1)	DGH22013	Screw: 2 each S7552	DGS__XL	DGC22013	Screw: S6552
		G	DGPG201334	DGPG201301	DGPG2013 __		DGH12013		DGS__YR	DGC12013	
		F	DGPF201334	DGPF201301	DGPF2013 __		DGS__XR		DGC12013		
		H	DGPH201334	DGPH201301	DGPH2013 __		DGS__YL		DGC12013		
3mm (.118")	13mm (1/2")	E	DGPE301334	DGPE301301	DGPE3013 __	'DGI3'  (Page 6-1)	DGH23013		DGS__XL	DGC23013	
		G	DGPG301334	DGPG301301	DGPG3013 __		DGH13013		DGS__YR	DGC13013	
		F	DGPF301334	DGPF301301	DGPF3013 __		DGS__XR		DGC13013		
		H	DGPH301334	DGPH301301	DGPH3013 __		DGS__YL		DGC13013		
4mm (.157")	13mm (1/2")	E	DGPE401334	DGPE401301	DGPE4013 __	'DGI4'  (Page 6-1)	DGH24013		DGS__XL	DGC24013	
		G	DGPG401334	DGPG401301	DGPG4013 __		DGH14013		DGS__YR	DGC14013	
		F	DGPF401334	DGPF401301	DGPF4013 __		DGS__XR		DGC14013		
		H	DGPH401334	DGPH401301	DGPH4013 __		DGS__YL		DGC14013		
	20mm (3/4")	E	DGPE402034	DGPE402001	DGPE4020 __		DGH24020	DGS__XL	DGC24020		
		G	DGPG402034	DGPG402001	DGPG4020 __		DGH14020	DGS__YR	DGC14020		
		F	DGPF402034	DGPF402001	DGPF4020 __		DGS__XR	DGC14020			
		H	DGPH402034	DGPH402001	DGPH4020 __		DGS__YL	DGC14020			
5mm (.197")	13mm (1/2")	E	DGPE501334	DGPE501301	DGPE5013 __	'DGI5'  (Page 6-1)	DGH25013	Wrench: W4025	DGS__XL	DGC25013	Wrench: W4025
		G	DGPG501334	DGPG501301	DGPG5013 __		DGH15013		DGS__YR	DGC15013	
		F	DGPF501334	DGPF501301	DGPF5013 __		DGS__XR		DGC15013		
		H	DGPH501334	DGPH501301	DGPH5013 __		DGS__YL		DGC15013		
	25mm (1")	E	DGPE502534	DGPE502501	DGPE5025 __		DGH25025		DGS__XL	DGC25025	
		G	DGPG502534	DGPG502501	DGPG5025 __		DGH15025		DGS__YR	DGC15025	
		F	DGPF502534	DGPF502501	DGPF5025 __		DGS__XR		DGC15025		
		H	DGPH502534	DGPH502501	DGPH5025 __		DGS__YL		DGC15025		
6mm (.236")	13mm (1/2")	E	DGPE601334	DGPE601301	DGPE6013 __	'DGI6'  (Page 6-1)	DGH26013		DGS__XL	DGC26013	
		G	DGPG601334	DGPG601301	DGPG6013 __		DGH16013		DGS__YR	DGC16013	
		F	DGPF601334	DGPF601301	DGPF6013 __		DGS__XR		DGC16013		
		H	DGPH601334	DGPH601301	DGPH6013 __		DGS__YL		DGC16013		
	25mm (1")	E	DGPE602534	DGPE602501	DGPE6025 __		DGH26025	DGS__XL	DGC26025		
		G	DGPG602534	DGPG602501	DGPG6025 __		DGH16025	DGS__YR	DGC16025		
		F	DGPF602534	DGPF602501	DGPF6025 __		DGS__XR	DGC16025			
		H	DGPH602534	DGPH602501	DGPH6025 __		DGS__YL	DGC16025			

## KAISER TOOL COMPANY, INC.

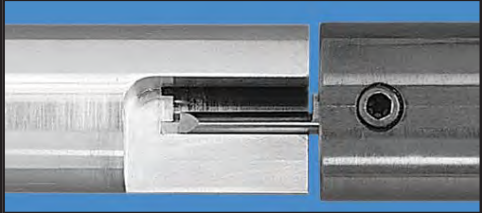
Phone: 888-THINBIT (888-844-6248) or (260) 484-3620 • Fax: 888-THINFAX (888-844-6329) or (260) 482-1881  
www.thinbit.com • General E-mail: thinbit@kaisertool.com • Orders: orders@thinbit.com • Quotes: quotes@thinbit.com

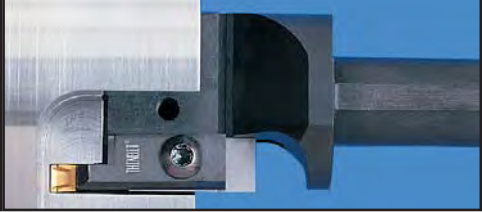
PRODUCT SELECTION GUIDE - FACE GROOVING

FACE GROOVING

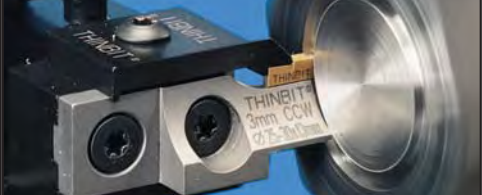
PAGE 2-3		<ul style="list-style-type: none"> <li>• For internal diameters of .125" and larger</li> <li>• Groove widths .004"-.250"</li> <li>• Solid carbide shanks in 1/8", 3/16", 1/4", 5/16", 3/8" and 1/2" diameter</li> </ul>
PAGE 2-5		<ul style="list-style-type: none"> <li>• For internal diameters of .415" and larger</li> <li>• Groove widths .004"-.125"</li> <li>• For depth of cut up to .125"</li> <li>• Insert can groove, bore and generate profiles</li> </ul>
PAGE 2-7		<ul style="list-style-type: none"> <li>• For internal diameters of 1.574" and larger</li> <li>• Groove widths 2, 3, 4, 5 and 6mm</li> <li>• For depth of cut to 1"</li> <li>• Inserts can also be used for parting and OD/ID grooving</li> </ul>
PAGE 2-9		<ul style="list-style-type: none"> <li>• Major diameters of .300", .750", 1.250" &amp; 3"</li> <li>• Groove widths .004" to .150" in .001" increments</li> <li>• Depth of cut 2-1/2 to 3 times width</li> <li>• Insert can groove, turn and generate profiles</li> </ul>
PAGE 2-9		<ul style="list-style-type: none"> <li>• Major diameters of .300", .750", 1.250" &amp; 3"</li> <li>• Groove widths .004" to .150" in .001" increments</li> <li>• Depth of cut 2-1/2 to 3 times width</li> <li>• Insert can groove, turn and generate profiles</li> </ul>
PAGE 2-11		<ul style="list-style-type: none"> <li>• For dovetail o-ring grooves</li> <li>• Groove widths .030", .050", .060", .070", .080", .090", .100", .125" &amp; .150"</li> <li>• Back clearance 24° (66° undercut)</li> <li>• Major diameters starting from .300"</li> </ul>
PAGE 2-13		<ul style="list-style-type: none"> <li>• For static o-ring grooves</li> <li>• Groove widths .086", .103", .122", .138" &amp; .125"</li> <li>• 7° included angle</li> <li>• Major diameters starting from .300"</li> </ul>
PAGE 2-15		<ul style="list-style-type: none"> <li>• Groove widths 2, 3, 4, 5 and 6mm</li> <li>• For depth of cut to 1"</li> <li>• Inserts can also be used for parting and OD/ID grooving</li> <li>• Major diameters starting from .787"</li> </ul>



www.thinbit.com/qr2-1

Scan this code for additional information.

**KAISER TOOL COMPANY, INC.**

Phone: 888-THINBIT (888-844-6248) or (260) 484-3620 • Fax: 888-THINFAX (888-844-6329) or (260) 482-1881  
 www.thinbit.com • General E-mail: thinbit@kaisertool.com • Orders: orders@thinbit.com • Quotes: quotes@thinbit.com

# TOOLING ORIENTATION GUIDE - FACE GROOVING

## FACE GROOVING

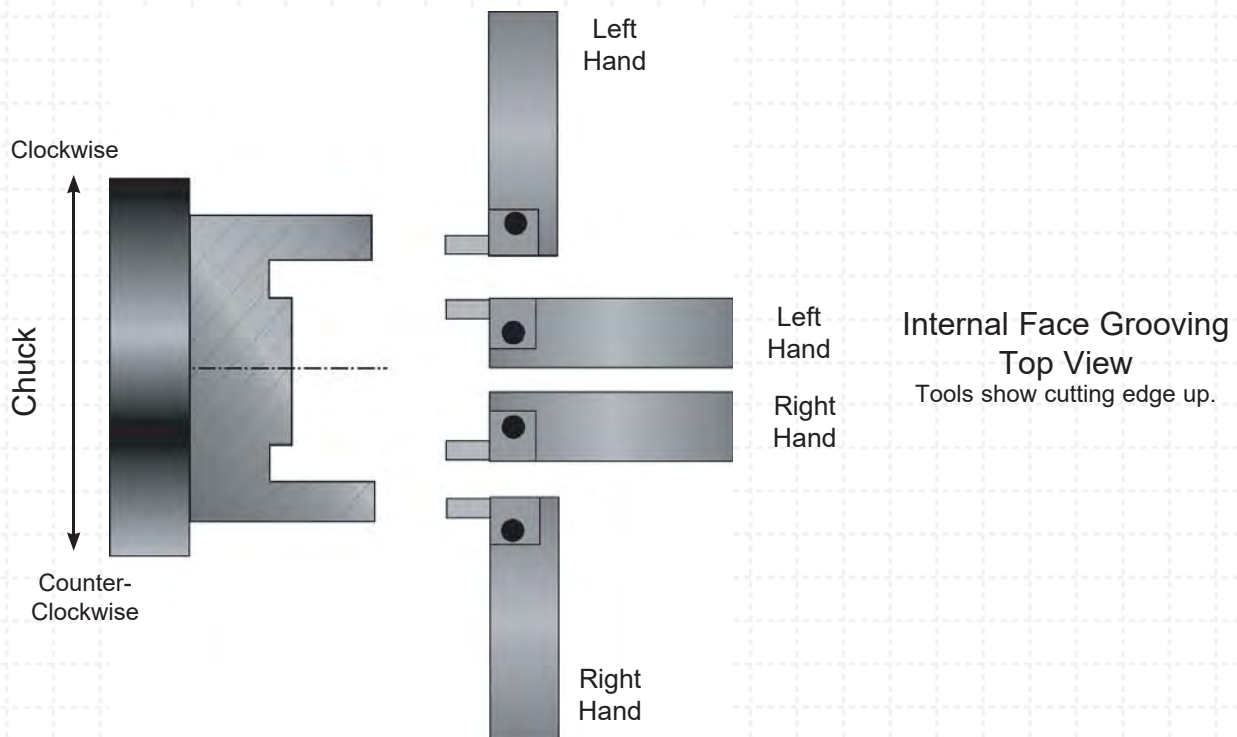
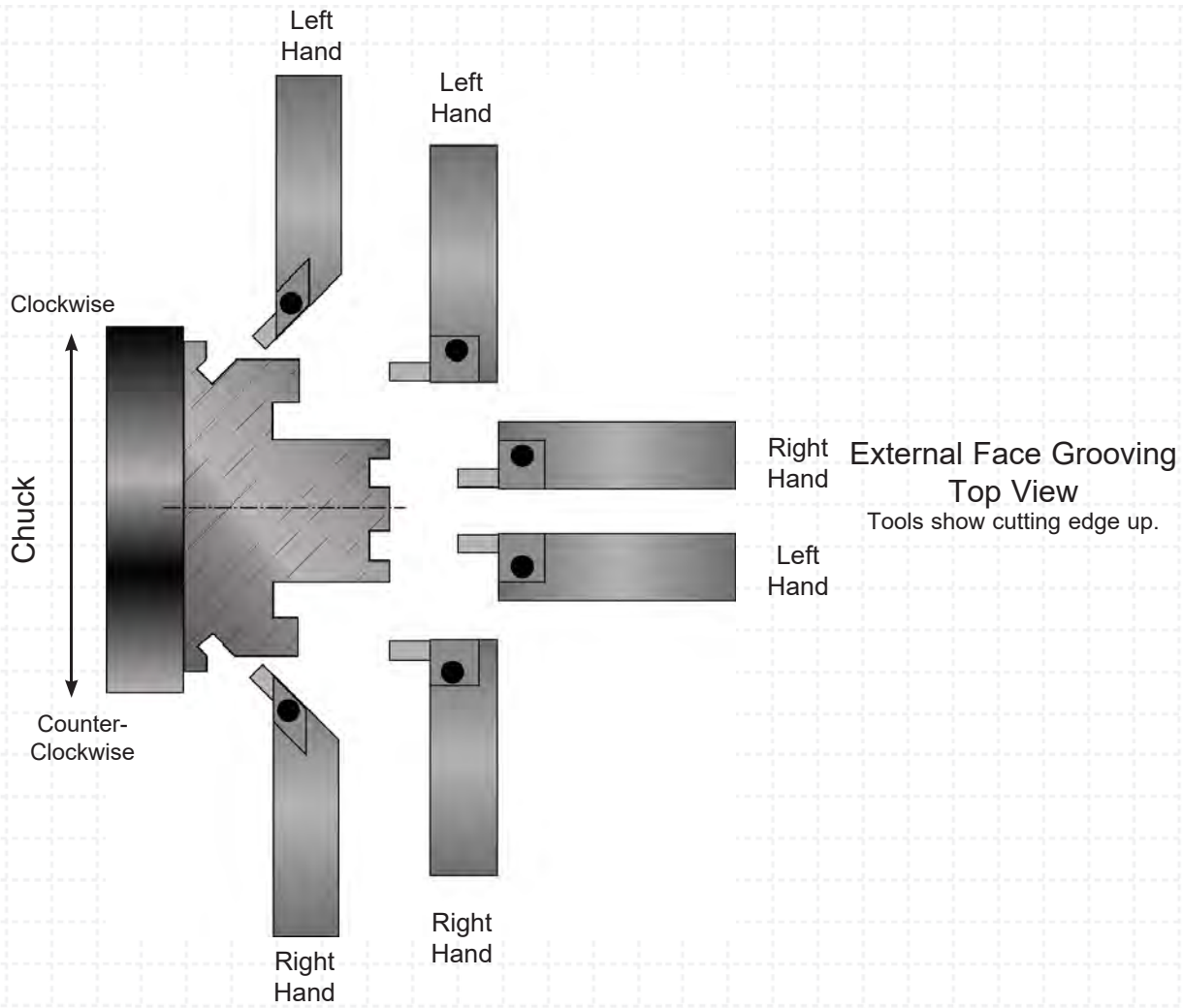

### KAISER TOOL COMPANY, INC.

## PRODUCT INFORMATION

- Internal face grooving for diameters .125" and larger.
- Elliptically ground necks for greater strength.
- .004" through .250" in .001" increments available.
- 1/8", 3/16", 1/4", 5/16", 3/8" and 1/2" shanks.
- Sub-micron grain **DURA-MAX® 2000** Carbide.
- Inserts available with TiN, TiAlN, TiCN and Diamond coating.

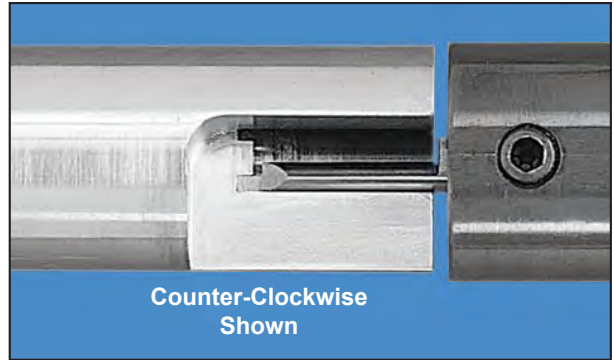

## MODIFICATIONS

SEE PAGE  
8-3  
FOR ADDITIONAL  
INFORMATION

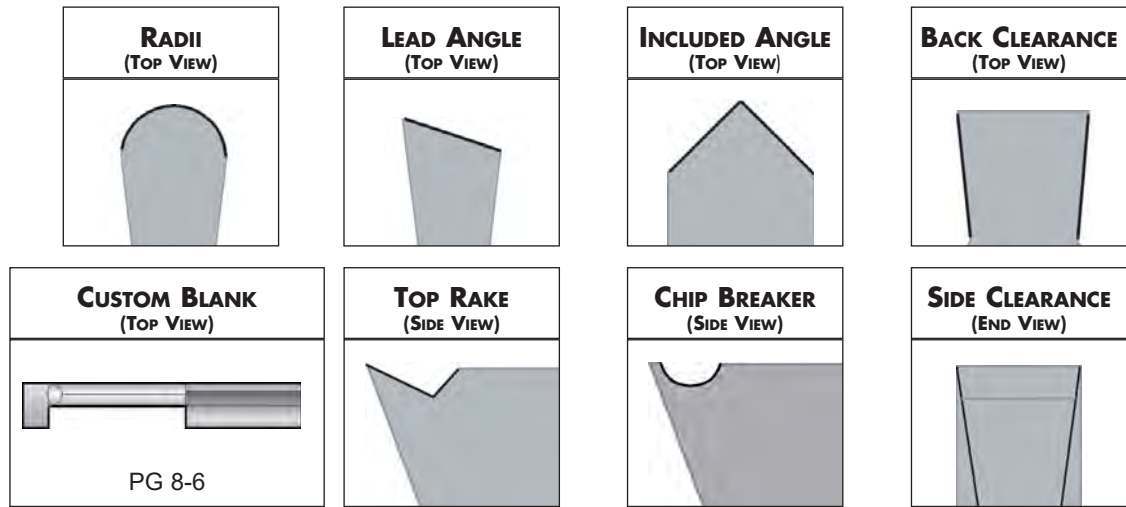

## TOOLHOLDER SELECTIONS

### ADAPTER STYLES

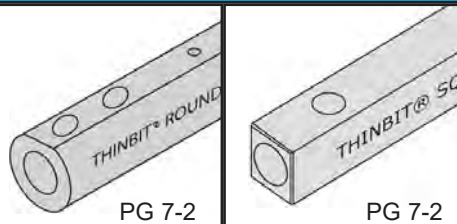

## TECHNICAL SECTIONS

PRODUCT DEMONSTRATION	SPEEDS AND FEEDS	APPLICATION REFERENCE	TROUBLESHOOTING
<p><a href="http://www.thinbit.com/qr2-3">www.thinbit.com/qr2-3</a></p>	PG 9-15	PGS 9-3 & 9-4	PG 9-7

## KAISER TOOL COMPANY, INC.

Phone: 888-THINBIT (888-844-6248) or (260) 484-3620 • Fax: 888-THINFAX (888-844-6329) or (260) 482-1881  
[www.thinbit.com](http://www.thinbit.com) • General E-mail: [thinbit@kaisertool.com](mailto:thinbit@kaisertool.com) • Orders: [orders@thinbit.com](mailto:orders@thinbit.com) • Quotes: [quotes@thinbit.com](mailto:quotes@thinbit.com)



# INTERNAL FACE GROOVING TOOLS

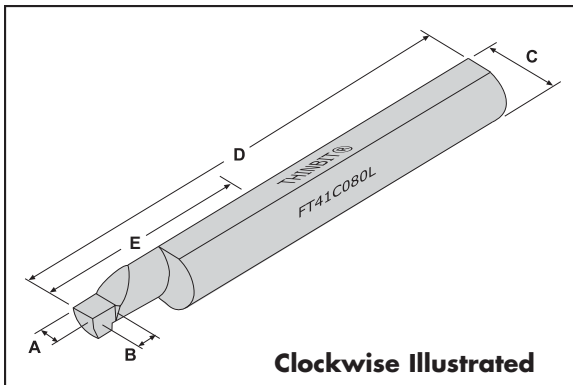

**Clockwise Illustrated**

FRONT RAKE: Primary 10°  
 BACK CLEARANCE: 2° ID side  
 SIDE CLEARANCE: 2° ID side  
 RADIUS: Sharp corner through full radius available  
 TOP RAKE: 0°  
 LEAD ANGLE: 0°

**INTERNAL  
FACE GROOVING**

## ORDERING INSTRUCTIONS

Complete the **ORDER CODE** in the table below that represents your selection of groove width and tool dimensions.

**EXAMPLE:**

The **ORDER CODE** for a 1/4" major diameter, clockwise rotation tool with an .080" groove width, .125" depth of cut and .750" reach is:

**FT41C Q8Q L**

Specify the Groove Width '**A**'



SPECIFICATIONS				ORDER CODE					INFORMATION	
Minimum Bore & Major Diameter  'C'	Groove Width Range  'A' ± .001"	Depth of Cut  'B'	Reach into Bore  'E'	DURA-MAX® 2000 Carbide See Page 9-15 for Speeds and Feeds		Add-ons Use 'Order Code' and Add			Overall Length  'D'	Toolholder Page 7-2  Use Toolholders Beginning With
				Counter-Clockwise	Clockwise	Full Radius Page 8-3	Corner Radius Page 8-3	Coating Page 9-6		
1/8"	.004"-.063"	Width DOC .004"-.020" = 3 x 'A' .021"-.063" = .062"	.375"	FT21C ___ R	FT21C ___ L	add 'FR'	add 'CR ___' (indicate size in .xxx")	TiN add 'C' TiCN add 'D' TiAIN add 'E' Diamond add 'F'	1.365" + 'B'	'AD'
3/16"	.004"-.093"	Width DOC .004"-.030" = 3 x 'A' .031"-.093" = .093"	.625"	FT31C ___ R	FT31C ___ L				1.865" + 'B'	'AD'
1/4"	.004"-.125"	Width DOC .004"-.041" = 3 x 'A' .042"-.125" = .125"	.750"	FT41C ___ R	FT41C ___ L				2.365" + 'B'	'AD'
5/16"	.004"-.156"	Width DOC .004"-.051" = 3 x 'A' .052"-.156" = .156"	1.000"	FT51C ___ R	FT51C ___ L				2.330" + 'B'	'AD'
3/8"	.004"-.187"	Width DOC .004"-.061" = 3 x 'A' .062"-.187" = .187"	1.250"	FT61C ___ R	FT61C ___ L				2.800" + 'B'	'AD'
1/2"	.004"-.250"	Width DOC .004"-.082" = 3 x 'A' .083"-.250" = .250"	1.750"	FT81C ___ R	FT81C ___ L				3.240" + 'B'	'AD'

## KAISER TOOL COMPANY, INC.

Phone: 888-THINBIT (888-844-6248) or (260) 484-3620 • Fax: 888-THINFAX (888-844-6329) or (260) 482-1881  
 www.thinbit.com • General E-mail: thinbit@kaisertool.com • Orders: orders@thinbit.com • Quotes: quotes@thinbit.com

## PRODUCT INFORMATION

- Internal face grooving and profiling for diameters of .415" and larger.
- Shank sizes 3/8", 1/2" and 5/8" in steel; 3/8" and 1/2" in heavy metal.
- 1/2" and 5/8" diameter toolholders are reversible for right and left hand orientation.
- Modifications can be provided on any of our tooling. Please contact us with your application requirements.



Right Hand Insert in  
Right Hand Toolholder  
Shown

	PRODUCT DEMONSTRATION	SPEEDS AND FEEDS	APPLICATION REFERENCE	TROUBLESHOOTING
<b>TECHNICAL SECTIONS</b>	 <a href="http://www.thinbit.com/qr2-5">www.thinbit.com/qr2-5</a>	PG 9-12	PGS 9-3 & 9-4	PG 9-7

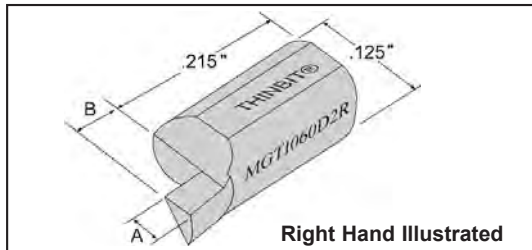

FRONT RAKE: 15°  
 BACK CLEARANCE: 2° both sides  
 SIDE CLEARANCE: 2° I.D. side  
 RADIUS: Sharp corner through full radius available  
 TOP RAKE: 0°  
 LEAD ANGLE: 0°  
 'A' TOLERANCE:  
 .004" - .063": +.0009/-.0000  
 .064" - .125": +.001/-.001

SPECIFICATIONS			ORDER CODE				
Insert Orientation	Insert Width  'A'	Depth of Cut  'B'	Insert Grades		Add-ons		
			See Page 9-5 for expanded material descriptions and Page 9-10 or 9-12 for speeds and feeds information		Use 'Order Code' and Add		
			DURA-MAX® 2000 Carbide For Steel & Interrupted Cutting	DURA-MAX® 5000 Carbide For Aluminum & Nonferrous	Full Radius Page 8-3	Corner Radius Page 8-3	Coating Page 9-6
Right Hand  For ID grooving use left hand 'MGT' Page 1-5  For face grooving use right hand 'MGTF' Page 2-6	.004"-.063"	<u>Width</u> <u>DOC</u> .004"-.031" = 2 x 'A' .032"-.063" = .063"	MGTI _ _ _D2R	MGTI _ _ _D5R	add 'FR'	add 'CR_ _ _'  (indicate size in .xxx")	TiN add 'C'  TiCN add 'D'  TiAlN add 'E'  Diamond add 'F'
	.064"-.125"	<u>Width</u> <u>DOC</u> .064"-.083" = 1.5 x 'A' .084"-.125" = .125"					
Left Hand  For ID grooving use right hand 'MGT' Page 1-5  For face grooving use left hand 'MGTF' Page 2-6	.004"-.063"	<u>Width</u> <u>DOC</u> .004"-.031" = 2 x 'A' .032"-.063" = .063"	MGTI _ _ _D2L	MGTI _ _ _D5L			
	.064"-.125"	<u>Width</u> <u>DOC</u> .064"-.083" = 1.5 x 'A' .084"-.125" = .125"					

## KAISER TOOL COMPANY, INC.

# I.D. FACE GROOVING TOOLS

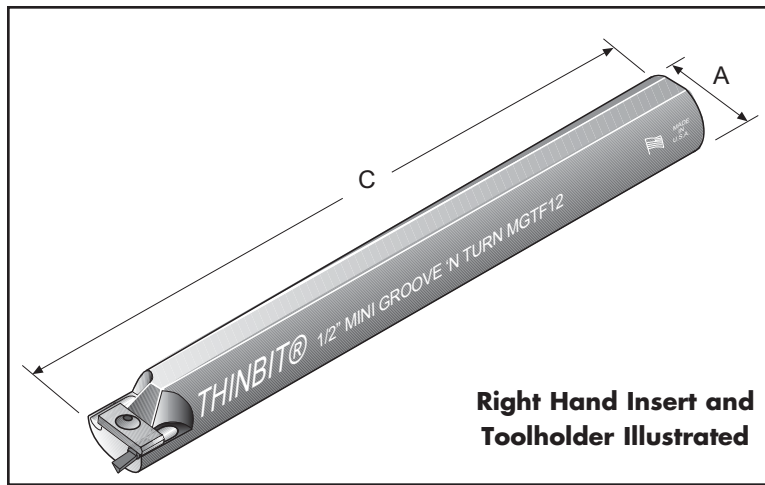

Note:

- 1/2" and 5/8" toolholders are reversible for right hand or left hand orientation.

- For face grooving:

<u>Insert Width</u>	<u>Depth of Cut</u>
.004"-.031"	2 x width
.032"-.063"	.063"
.064"-.083"	1.5 x width
.084"-.125"	.125"

**I.D. FACE GROOVING**

## ORDERING INSTRUCTIONS

Select the **ORDER CODE** in the table below that represents your selection of tool specifications.

**EXAMPLE:**

The **ORDER CODE** for a .530" minimum bore and a 1/2" steel shank is:  
**MGTF12**

SPECIFICATIONS		ORDER CODE				INFORMATION		
Minimum Bore & Major Diameter	Orientation & Toolholder Material	Toolholder Package  Includes Shank, Clamp and Hardware	Replacement Parts			Shank Diameter  'A'	Shank Length  'C'	Inserts Page 2-5  Use Inserts Beginning With
			Clamp Only	Screw Only	Wrench Only			
.415"	Right Hand Steel	MGTF38R	MGC1	F31	W31	3/8"	5.500"	'MGTI' Use right hand inserts
	Right Hand Heavy Metal	MGTF38RHM					5.485"	
	Left Hand Steel	MGTF38L					5.500"	'MGTI' Use left hand inserts
	Left Hand Heavy Metal	MGTF38LHM					5.485"	
.530"	Steel	MGTF12				1/2"	5.500"	'MGTI' Use with left hand inserts for clockwise or with right hand inserts for counter-clockwise
	Heavy Metal	MGTF12HM					5.485"	
.650"	Steel	MGTF58				5/8"	5.500"	

### KAISER TOOL COMPANY, INC.

## PRODUCT INFORMATION

- Internal face grooving for diameters 1.574" and larger with depth of cut to 1".
- Shank sizes 3/4", 1", 20mm & 25mm.
- Modular tooling system will also accept OD & external face grooving heads. See compatibility guide on Page 9-8.
- If square shank is required, see Page 7-14, package styles 'S', 'T', 'U' and 'V'.
- Modifications can be provided on any of our tooling. Please contact us with your application requirements.

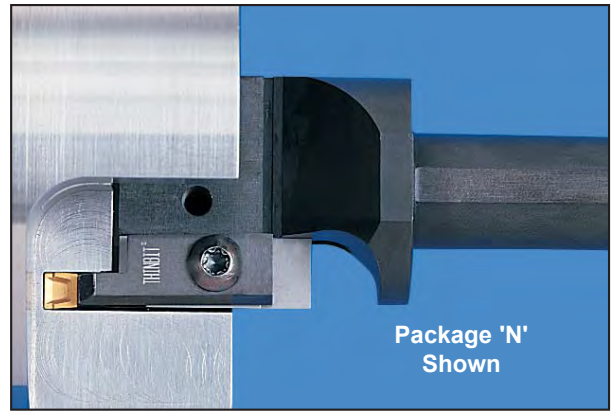

## INSERT SELECTIONS

SEE PAGE 6-1

### INSERT STYLES

#### CORNER RADIUS (TOP VIEW)



#### SHARP CORNER (TOP VIEW)



## TECHNICAL SECTIONS

### PRODUCT DEMONSTRATION



[www.thinbit.com/qr2-7](http://www.thinbit.com/qr2-7)

### SPEEDS AND FEEDS

PG 9-12

### APPLICATION REFERENCE

PGS 9-3 & 9-4

### TROUBLESHOOTING

PG 9-7

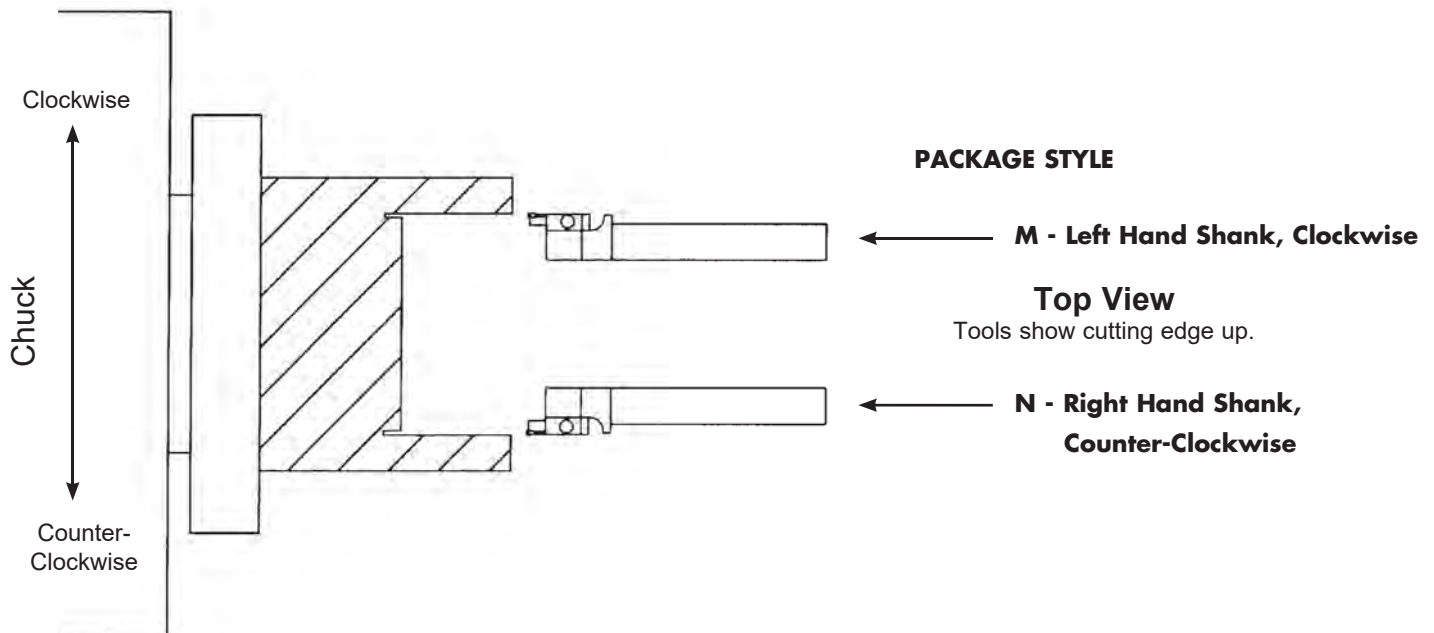

**Note:** If square shank is required, see Page 7-14, package styles 'S','T','U' and 'V'.

## KAISER TOOL COMPANY, INC.

Phone: 888-THINBIT (888-844-6248) or (260) 484-3620 • Fax: 888-THINFAX (888-844-6329) or (260) 482-1881  
[www.thinbit.com](http://www.thinbit.com) • General E-mail: [thinbit@kaisertool.com](mailto:thinbit@kaisertool.com) • Orders: [orders@thinbit.com](mailto:orders@thinbit.com) • Quotes: [quotes@thinbit.com](mailto:quotes@thinbit.com)



# I.D. FACE GROOVING TOOLS

## ORDERING INSTRUCTIONS

**Complete** the **ORDER CODE** in the table below that represents your selection of major diameter.

**EXAMPLE:**

The **ORDER CODE** for a 3mm insert width, toolholder package style 'N' with a .500" depth of cut, 1" shank and 1.75" major diameter is:

**DGPN301301 4 5**

Specify Major Diameter '**CODE**' here \_\_\_\_\_ ↑

**I.D. FACE GROOVING**

SPECIFICATIONS			ORDER CODE											
Insert Width	Depth of Cut	Package Style	Toolholder Package				Inserts	Replacement Parts						
			Includes Shank, Head, Clamp and Hardware					Use Inserts Beginning With	Head	Head Hardware	Shank 34 = 3/4" 01 = 1" 20 = 20mm 25 = 25mm	Clamp	Clamp Hardware	
3/4" Shank 7" Long	1" Shank 7" Long	20mm Shank 178mm (7") Long	25mm Shank 178mm (7") Long											
2mm (.078")	13mm (1/2")	M	DGPM201334 __	DGPM201301 __	DGPM201320 __	DGPM201325 __	'DG12' (Page 6-1)	DGH52013 __	Screw: 2 each S7552	DGS__ZL	DGC52013	Screw: S6552		
		N	DGPN201334 __	DGPN201301 __	DGPN201320 __	DGPN201325 __		DGH62013 __		DGS__ZR	DGC62013			
3mm (.118")	13mm (1/2")	M	DGPM301334 __	DGPM301301 __	DGPM301320 __	DGPM301325 __	'DG13' (Page 6-1)	DGH53013 __		DGS__ZL	DGC53013			
		N	DGPN301334 __	DGPN301301 __	DGPN301320 __	DGPN301325 __		DGH63013 __		DGS__ZR	DGC63013			
4mm (.157")	13mm (1/2")	M	DGPM401334 __	DGPM401301 __	DGPM401320 __	DGPM401325 __	'DG14' (Page 6-1)	DGH54013 __		DGS__ZL	DGC54013			
		N	DGPN401334 __	DGPN401301 __	DGPN401320 __	DGPN401325 __		DGH64013 __		DGS__ZR	DGC64013			
	20mm (3/4")	M	DGPM402034 __	DGPM402001 __	DGPM402020 __	DGPM402025 __		DGH54020 __		DGS__ZL	DGC54020			
		N	DGPN402034 __	DGPN402001 __	DGPN402020 __	DGPN402025 __		DGH64020 __		DGS__ZR	DGC64020			
5mm (.197")	13mm (1/2")	M	DGPM501334 __	DGPM501301 __	DGPM501320 __	DGPM501325 __	'DG15' (Page 6-1)	DGH55013 __		Wrench: W4025	DGS__ZL		DGC55013	Wrench: W4025
		N	DGPN501334 __	DGPN501301 __	DGPN501320 __	DGPN501325 __		DGH65013 __			DGS__ZR		DGC65013	
	25mm (1")	M	DGPM502534 __	DGPM502501 __	DGPM502520 __	DGPM502525 __		DGH55025 __	DGS__ZL		DGC55025			
		N	DGPN502534 __	DGPN502501 __	DGPN502520 __	DGPN502525 __		DGH65025 __	DGS__ZR		DGC65025			
6mm (.236")	13mm (1/2")	M	DGPM601334 __	DGPM601301 __	DGPM601320 __	DGPM601325 __	'DG16' (Page 6-1)	DGH56013 __	DGS__ZL	DGC56013				
		N	DGPN601334 __	DGPN601301 __	DGPN601320 __	DGPN601325 __		DGH66013 __	DGS__ZR	DGC66013				
	25mm (1")	M	DGPM602534 __	DGPM602501 __	DGPM602520 __	DGPM602525 __		DGH56025 __	DGS__ZL	DGC56025				
		N	DGPN602534 __	DGPN602501 __	DGPN602520 __	DGPN602525 __		DGH66025 __	DGS__ZR	DGC66025				



Major Diameter Range	Code
1.574"-1.968" (40-50mm)	45
1.968"-2.362" (50-60mm)	56
2.362"-2.952" (60-75mm)	67
2.952"-3.937" (75-100mm)	71
3.937"-5.905" (100-150mm)	11
5.905"-11.811" (150-300mm)	13
11.811"- ∞ (300mm-∞)	30

**Note:**  
As long as first plunge is made within major diameter range and each following plunge overlaps, groove width can be increased toward or away from center of part.

### KAISER TOOL COMPANY, INC.

# GROOVE 'N TURN® INSERTS

U.S. PATENT NOS. 6,688,816 and 6,824,333

## PRODUCT INFORMATION

- Face grooving for major diameters .300", .750", 1.250", 3" and greater.
- Face grooving with a central hub, recessed or flat face.
- .004" - .150" in .001" increments available.
- Sub-micron grain **DURA-MAX® 2000** and **5000** Carbides.
- Inserts available with TiN, TiAlN, TiCN and Diamond coating.



## MODIFICATIONS

SEE PAGES 8-2 & 8-3 FOR ADDITIONAL INFORMATION

<b>RADII (TOP VIEW)</b>	<b>DEPTH OF CUT (TOP VIEW)</b>	<b>SIZING (TOP VIEW)</b>	<b>BACK CLEARANCE (TOP VIEW)</b>
<b>LEAD ANGLE (TOP VIEW)</b>	<b>TOP RAKE (SIDE VIEW)</b>	<b>CHIP BREAKER (SIDE VIEW)</b>	<b>SIDE CLEARANCE (END VIEW)</b>

## TOOLHOLDER SELECTIONS

### CNC, SWISS, CONVENTIONAL STYLE

### ROUND STYLE

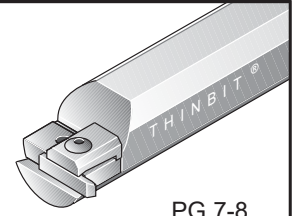
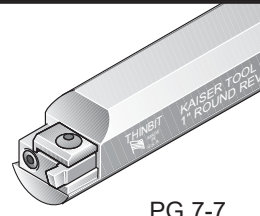
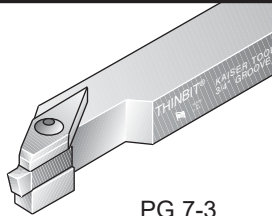

### 45° STYLE

### SWISS FACE STYLE



## TECHNICAL SECTIONS

### PRODUCT DEMONSTRATION



[www.thinbit.com/qr2-9](http://www.thinbit.com/qr2-9)

### SPEEDS AND FEEDS

PG 9-12

### APPLICATION REFERENCE

PGS 9-3 & 9-4

### TROUBLESHOOTING

PG 9-7

## KAISER TOOL COMPANY, INC.

Phone: 888-THINBIT (888-844-6248) or (260) 484-3620 • Fax: 888-THINFAX (888-844-6329) or (260) 482-1881  
[www.thinbit.com](http://www.thinbit.com) • General E-mail: [thinbit@kaisertool.com](mailto:thinbit@kaisertool.com) • Orders: [orders@thinbit.com](mailto:orders@thinbit.com) • Quotes: [quotes@thinbit.com](mailto:quotes@thinbit.com)

# FACE GROOVING INSERTS

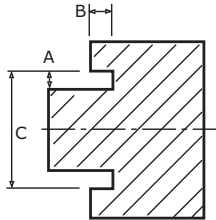
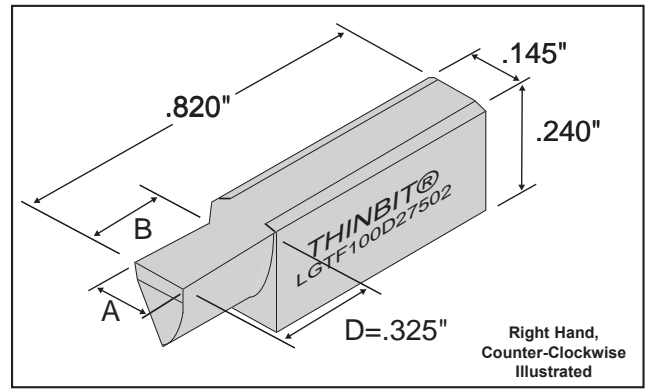
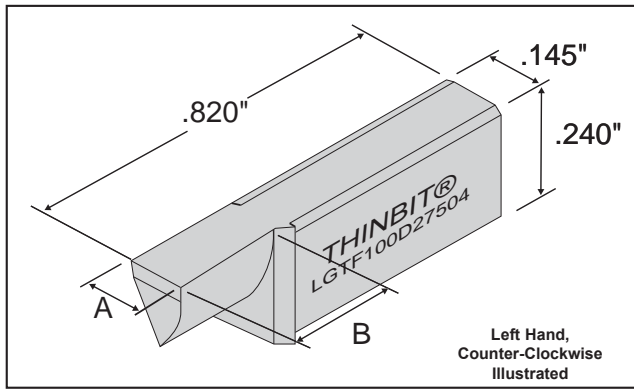

FRONT RAKE: Primary 10° honed, Secondary 15°  
 BACK CLEARANCE: 2-1/2° both sides  
 SIDE CLEARANCE: .004" - .019" - 0° ID side  
 .020" - .150" - 5° ID side  
 RADIUS: Sharp corner through full radius available  
 TOP RAKE: 0°  
 LEAD ANGLE: 0°

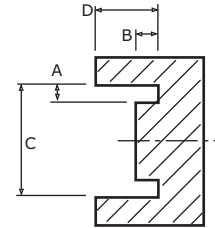

Cut with a LH CCW Insert

**NOTE:** Capable of grooving along a shoulder

Cut with a RH CCW Insert

## ORDERING INSTRUCTIONS

### EXAMPLE:

Sample **ORDER CODE** for a left hand/counter-clockwise, .100" wide insert in **DURA-MAX® 2000**, with a .750" major diameter and no corner radius is:

**LGTF 100 D27504**

Specify the Insert Width 'A'

SPECIFICATIONS				ORDER CODE			INFO.		
Insert Orientation	Insert Width	Depth of Cut	Major Diameter	Insert Grades <small>See Page 9-5 for expanded material descriptions and Page 9-12 for Speeds and Feeds information</small>		Add-ons <small>Use 'Order Code' and Add</small>		Toolholder Catalog Section 7  Use Toolholders Beginning With 'L'	
	'A' ± .001"	'B'	Can be used on any diameter equal to or greater than listed	DURA-MAX® 2000 Carbide For Steel & Interrupted Cutting	DURA-MAX® 5000 Carbide For Aluminum & Nonferrous	Full Radius Page 8-3	Corner Radius Page 8-3		Coating Page 9-6
Left Hand/ Counter-Clockwise	.004" - .150"	Width    D.O.C. .004"-.033" = 3 x 'A' .034"-.039" = .100" .040"-.100" = 2.5 x 'A' .101"-.150" = .250"	.300"	LGTF ___ D23004	LGTF ___ D53004	add 'FR'	add 'CR___' (indicate size in .xxx")	TiN add 'C' TiCN add 'D' TiAIN add 'E' Diamond add 'F'	For shoulder cutting use left hand straight holder or right hand 90° holder  Use right hand or left hand straight holder or right hand 90° holder
			.750"	LGTF ___ D27504	LGTF ___ D57504				
			1.250"	LGTF ___ D212504	LGTF ___ D512504				
			* 3.000"	LGT ___ D2L	LGT ___ D5L				
Right Hand/ Counter-Clockwise	.004" - .150"	Width    D.O.C. .004"-.033" = 3 x 'A' .034"-.039" = .100" .040"-.100" = 2.5 x 'A' .101"-.150" = .250"	.300"	LGTF ___ D23002	LGTF ___ D53002	add 'FR'	add 'CR___' (indicate size in .xxx")	TiAIN add 'E' Diamond add 'F'	Use right hand or left hand straight holder or right hand 90° holder
			.750"	LGTF ___ D27502	LGTF ___ D57502				
			1.250"	LGTF ___ D212502	LGTF ___ D512502				
			* 3.000"	LGT ___ D2R	LGT ___ D5R				

\* 3.000" Major Diameter Excludes .004" - .019" Insert Width Due to Side Clearance

## KAISER TOOL COMPANY, INC.

Phone: 888-THINBIT (888-844-6248) or (260) 484-3620 • Fax: 888-THINFAX (888-844-6329) or (260) 482-1881  
 www.thinbit.com • General E-mail: thinbit@kaisertool.com • Orders: orders@thinbit.com • Quotes: quotes@thinbit.com

INSERTS  
FACE GROOVING

# GROOVE 'N TURN® INSERTS

U.S. PATENT NOS. 6,688,816 and 6,824,333

## PRODUCT INFORMATION

- For Dovetail O-Ring face grooving and OD/ID grooving.
- Groove Widths .030", .050", .060", .070", .080", .090", .100", .125" & .150".
- Major diameters from .300".
- Sub-micron grain **DURA-MAX® 2000** and **5000** Carbides.
- Inserts available with TiN, TiCN, TiAlN or Diamond film coating.



## MODIFICATIONS

SEE PAGES  
8-2 & 8-3  
FOR ADDITIONAL  
INFORMATION

<b>RADII</b> (TOP VIEW)	<b>DEPTH OF CUT</b> (TOP VIEW)	<b>SIZING</b> (TOP VIEW)	<b>BACK CLEARANCE</b> (TOP VIEW)
<b>LEAD ANGLE</b> (TOP VIEW)	<b>TOP RAKE</b> (SIDE VIEW)	<b>CHIP BREAKER</b> (SIDE VIEW)	<b>SIDE CLEARANCE</b> (END VIEW)

## TOOLHOLDER SELECTIONS

### CNC, SWISS, CONVENTIONAL STYLE

### ROUND STYLE

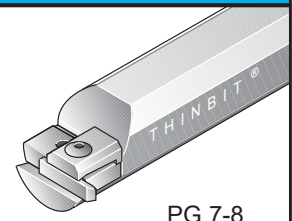
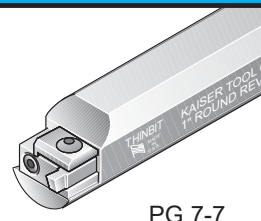
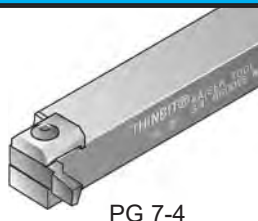
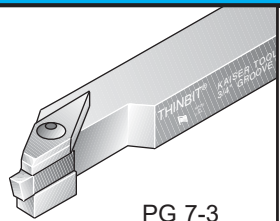

### 45° STYLE

### SWISS FACE STYLE



## TECHNICAL SECTIONS

### PRODUCT DEMONSTRATION



[www.thinbit.com/qr2-11](http://www.thinbit.com/qr2-11)

### SPEEDS AND FEEDS

PG 9-12

### APPLICATION REFERENCE

PGS 9-3 & 9-4

### TROUBLESHOOTING

PG 9-7

## KAISER TOOL COMPANY, INC.

Phone: 888-THINBIT (888-844-6248) or (260) 484-3620 • Fax: 888-THINFAX (888-844-6329) or (260) 482-1881  
www.thinbit.com • General E-mail: [thinbit@kaisertool.com](mailto:thinbit@kaisertool.com) • Orders: [orders@thinbit.com](mailto:orders@thinbit.com) • Quotes: [quotes@thinbit.com](mailto:quotes@thinbit.com)



# DOVETAIL O-RING FACE GROOVING INSERTS

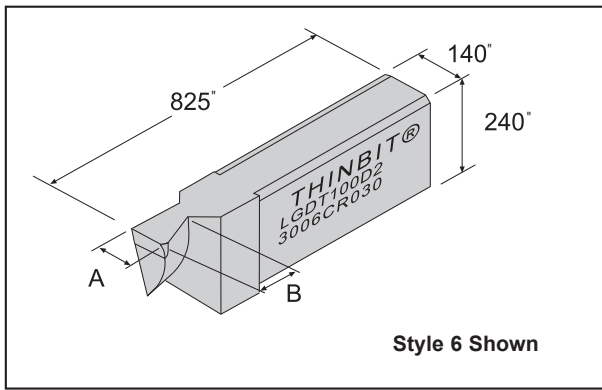

Style 6 Shown

FRONT RAKE: Primary 10° honed, Secondary 15°  
 BACK CLEARANCE: 24° one side  
 SIDE CLEARANCE: Depends on major diameter  
 RADIUS: On 24° side only  
 TOP RAKE: 0°  
 LEAD ANGLE: 0°

**Notes:**

- For best performance, form undercut by profiling.
- If using on either an ID Bore or OD Shaft contact us for assistance.
- Half dovetail form requires a radius on both corners.

DOVE TAIL FACE GROOVING

## ORDERING INSTRUCTIONS

Select the **ORDER CODE** in the table below that represents your selection of groove width and insert grade.

**EXAMPLE:**

The **ORDER CODE** for a left hand/counter-clockwise, .100" wide OD side insert in **DURA-MAX® 2000**, with a .300" major diameter and a .030" corner radius is:  
**LGDT100D23006CR030**

SPECIFICATIONS				ORDER CODE				INFO.	
Insert Orientation & Radius	Insert Width 'A'	Depth of Cut 'B'	Radius	Insert Grades See Page 9-5 for expanded material descriptions and Page 9-12 for Speeds and Feeds information				Add-ons Use 'Order Code' and Add Coating Page 9-6	Toolholder Catalog Section 7  Use Toolholders Beginning With
				DURA-MAX® 2000 Carbide For Steel & Interrupted Cutting		DURA-MAX® 5000 Carbide For Aluminum & Nonferrous			
	± .001"			Style 5 (ID Tool)	Style 6 (OD Tool)	Style 5 (ID Tool)	Style 6 (OD Tool)		
Left Hand/ Counter-Clockwise	.030"	.030"	.015"	LGDT030D2__5CR015	LGDT030D2__6CR015	LGDT030D5__5CR015	LGDT030D5__6CR015		'L'
	.050"	.070"	.015"	LGDT050D2__5CR015	LGDT050D2__6CR015	LGDT050D5__5CR015	LGDT050D5__6CR015		
	.060"	.070"	.015"	LGDT060D2__5CR015	LGDT060D2__6CR015	LGDT060D5__5CR015	LGDT060D5__6CR015	TiN add 'C'	
	.070"	.100"	.015"	LGDT070D2__5CR015	LGDT070D2__6CR015	LGDT070D5__5CR015	LGDT070D5__6CR015	TiCN add 'D'	
	.080"	.100"	.015"	LGDT080D2__5CR015	LGDT080D2__6CR015	LGDT080D5__5CR015	LGDT080D5__6CR015	TiAIN add 'E'	
	.090"	.115"	.015"	LGDT090D2__5CR015	LGDT090D2__6CR015	LGDT090D5__5CR015	LGDT090D5__6CR015		
	.100"	.125"	.015"	LGDT100D2__5CR015	LGDT100D2__6CR015	LGDT100D5__5CR015	LGDT100D5__6CR015	Diamond add 'F'	
	.100"	.125"	.030"	LGDT100D2__5CR030	LGDT100D2__6CR030	LGDT100D5__5CR030	LGDT100D5__6CR030		
	.125"	.190"	.030"	LGDT125D2__5CR030	LGDT125D2__6CR030	LGDT125D5__5CR030	LGDT125D5__6CR030		
	.150"	.200"	.030"	LGDT150D2__5CR030	LGDT150D2__6CR030	LGDT150D5__5CR030	LGDT150D5__6CR030		

Major Diameter Code

Major Diameter	Code
.300"	300
.500"	500
1.000"	1000
1.500"	1500
2.000"	2000
3.000"	3000

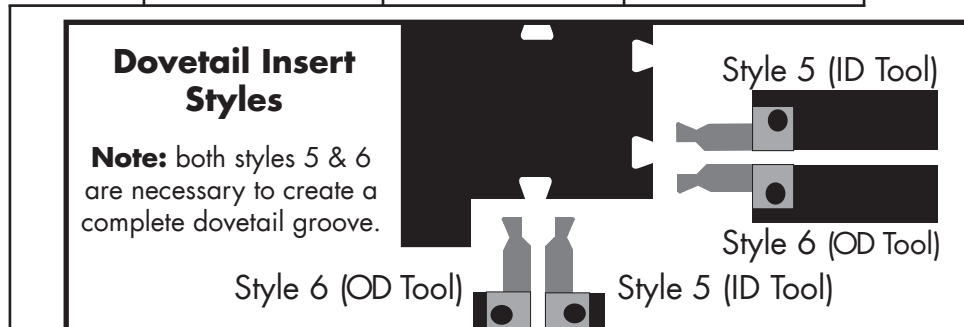

## KAISER TOOL COMPANY, INC.

## PRODUCT INFORMATION

- For Static O-Ring Face Grooving.
- Groove widths .086", .103", .122", .125" & .138".
- 7° included angle.
- Major diameters starting from .300".
- Sub-micron grain **DURA-MAX® 2000** and **5000** Carbides.
- Inserts available with TiN, TiCN, TiAlN or Diamond film coating.



## MODIFICATIONS

SEE PAGES  
8-2 & 8-3  
FOR ADDITIONAL  
INFORMATION

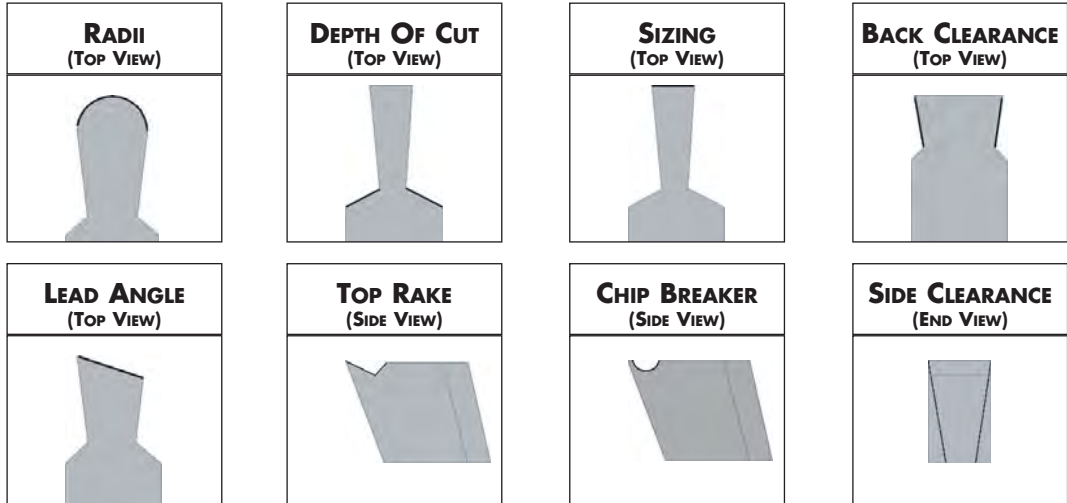

## TOOLHOLDER SELECTIONS

### CNC, SWISS, CONVENTIONAL STYLE

### ROUND STYLE

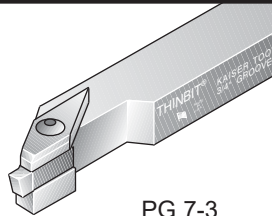

PG 7-3



PG 7-4

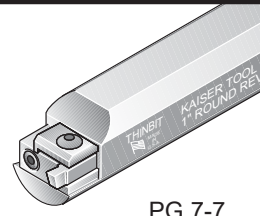

PG 7-7

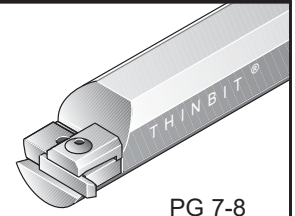

PG 7-8

### 45° STYLE

### SWISS FACE STYLE



PG 7-12



PG 7-6

## TECHNICAL SECTIONS

### PRODUCT DEMONSTRATION



[www.thinbit.com/qr2-13](http://www.thinbit.com/qr2-13)

### SPEEDS AND FEEDS

PG 9-12

### APPLICATION REFERENCE

PGS 9-3 & 9-4

### TROUBLESHOOTING

PG 9-7

## KAISER TOOL COMPANY, INC.

# STATIC O-RING FACE GROOVING INSERTS

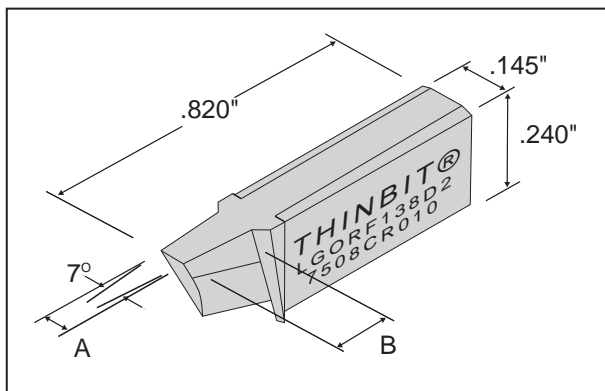

FRONT RAKE: Primary 10° honed, Secondary 15°  
 BACK CLEARANCE: 7° included angle  
 SIDE CLEARANCE: 5° both sides  
 RADIUS: .010" or .020"  
 TOP RAKE: 0°  
 LEAD ANGLE: 0°  
 DEPTH OF CUT: .170" or .250"

STATIC O-RING  
FACE GROOVING

## ORDERING INSTRUCTIONS

Select the **ORDER CODE** in the table below that represents your selection of groove width and insert grade.

### EXAMPLE:

The **ORDER CODE** for a counter-clockwise, .138" wide insert in **DURA-MAX® 2000**, with a .750" major diameter and a .010" corner radius is:

**LGORF138D27508CR010**

SPECIFICATIONS				ORDER CODE		INFO.	
Insert Orientation & Radius	Insert Width  'A'  ± .001"	Depth of Cut  'B'	Major Diameter  Can be used on any diameter equal to or greater than listed	Insert Grades See Page 9-5 for expanded material descriptions and Page 9-12 for Speeds and Feeds information		Add-ons Use 'Order Code' and Add  Coating Page 9-6	Toolholder Catalog Section 7  Use Toolholders Beginning With
				DURA-MAX® 2000 Carbide For Steel & Interrupted Cutting	DURA-MAX® 5000 Carbide For Aluminum & Non-ferrous		
Counter-Clockwise; .010" Corner Radius	.086"	.250"	.300"	LGORF086D23008CR010	LGORF086D53008CR010	TiN add 'C' TiCN add 'D' TiAlN add 'E' Diamond add 'F'	'L'  Use left hand straight holder or right hand 90° holder
			.750"	LGORF086D27508CR010	LGORF086D57508CR010		
	.103"	.250"	.300"	LGORF103D23008CR010	LGORF103D53008CR010		
			.750"	LGORF103D27508CR010	LGORF103D57508CR010		
	.122"	.250"	.300"	LGORF122D23008CR010	LGORF122D53008CR010		
			.750"	LGORF122D27508CR010	LGORF122D57508CR010		
	.138"	.170"	.300"	LGORF138D23008CR010	LGORF138D53008CR010		
			.750"	LGORF138D27508CR010	LGORF138D57508CR010		
Counter-Clockwise; .020" Corner Radius	.125"	.250"	.300"	LGORF125D23008CR020	LGORF125D53008CR020		
			.750"	LGORF125D27508CR020	LGORF125D57508CR020		

## KAISER TOOL COMPANY, INC.



Phone: 888-THINBIT (888-844-6248) or (260) 484-3620 • Fax: 888-THINFAX (888-844-6329) or (260) 482-1881  
 www.thinbit.com • General E-mail: thinbit@kaisertool.com • Orders: orders@thinbit.com • Quotes: quotes@thinbit.com

## PRODUCT INFORMATION

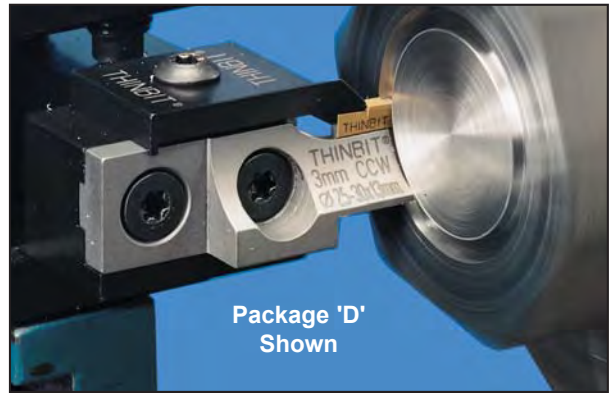
- External face grooving with depth of cut to 1".
- Shank sizes 3/4", 1", 16mm, 20mm and 25mm in straight and 90° orientations.
- Modular tooling system will also accept OD & internal face grooving heads. See compatibility guide on Page 9-8.
- If round shanks are required, see Page 7-13, package styles 'O' and 'P'.
- Modifications can be provided on any of our tooling. Please contact us with your application requirements.
- Major diameter starting from .787".

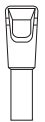

Package 'D' Shown

INSERT SELECTIONS SEE PAGE 6-1	INSERT STYLES	
	CORNER RADIUS (TOP VIEW)	SHARP CORNER (TOP VIEW)
		

TECHNICAL SECTIONS	PRODUCT DEMONSTRATION	SPEEDS AND FEEDS	APPLICATION REFERENCE	TROUBLESHOOTING
	 <a href="http://www.thinbit.com/qr2-15">www.thinbit.com/qr2-15</a>	PG 9-12	PGS 9-3 & 9-4	PG 9-7

## ORDERING INSTRUCTIONS

### 3/4", 1" and Metric Shanks

Select the **ORDER CODE** in the table at right that represents your selection of major diameter.

#### EXAMPLE:

The **ORDER CODE** for a 3mm insert width, toolholder package style 'C' with a .500" depth of cut, 1" shank and 1" major diameter is:

**DGPC301301 23**

Specify the 'SHANK SIZE' and MAJOR DIAMETER 'CODE'

#### PACKAGE STYLE

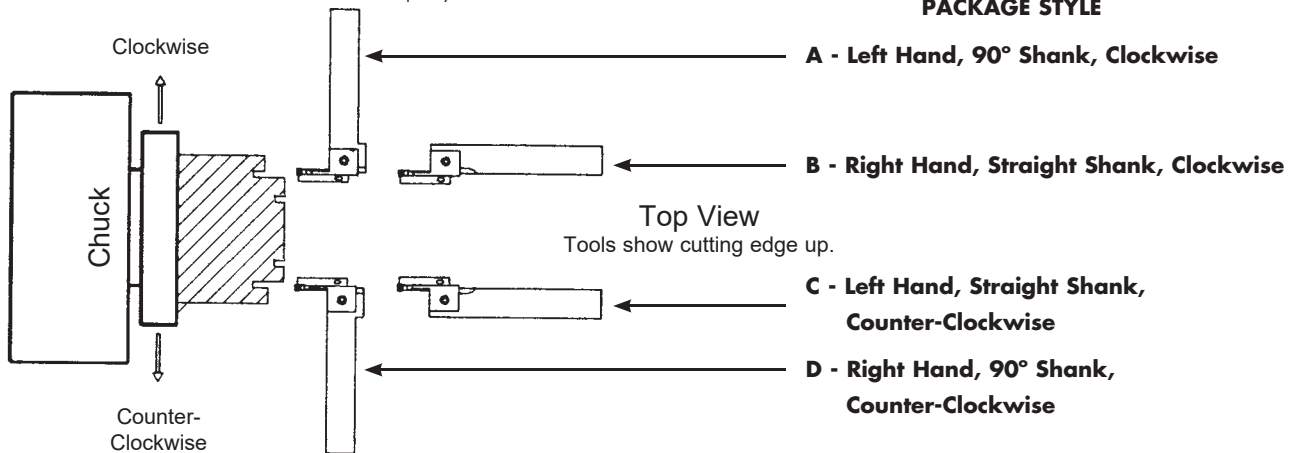

**Note: If round shanks are required, see Page 7-13, package styles 'O' and 'P'.**

## KAISER TOOL COMPANY, INC.



# FACE GROOVING TOOLS

SPECIFICATIONS			ORDER CODE											
Insert Width	Depth of Cut	Package Style	Toolholder Package			Inserts	Replacement Parts							
			Includes Shank, Head, Clamp and Hardware				Section 6 Use Inserts Beginning With	Head	Head Hardware	Shank 3/4 = 3/4" 01 = 1" 16 = 16mm 20 = 20mm 25 = 25mm	Clamp	Clamp Hardware		
See Page 2-15		3/4" Shank 3/4"x3/4"x5"	1" Shank 1"x1"x5"	Metric Shanks 16 = 16x16x125mm 20 = 20x1"x125mm 25 = 25x1"x125mm										
2mm (.078")	13mm (1/2")	A	DGPA201334__	DGPA201301__	DGPA2013__	'DGI2'  (Page 6-1)	DGH32013__	DGS__YL	DGC12013	Screw: 2 each S7552	Wrench: W4025			
		B	DGPB201334__	DGPB201301__	DGPB2013__							DGS__XR		
		C	DGPC201334__	DGPC201301__	DGPC2013__							DGS__XL		
		D	DGPD201334__	DGPD201301__	DGPD2013__							DGS__YR		
3mm (.118")	13mm (1/2")	A	DGPA301334__	DGPA301301__	DGPA3013__	Use 'DGMI3' for major diameter codes '02' & '25' 'DGI3' for all others (Page 6-1)	DGH33013__	DGS__YL	DGC13013	Screw: 2 each S7552	Wrench: W4025			
		B	DGPB301334__	DGPB301301__	DGPB3013__							DGS__XR		
		C	DGPC301334__	DGPC301301__	DGPC3013__							DGS__XL		
		D	DGPD301334__	DGPD301301__	DGPD3013__							DGS__YR		
4mm (.157")	13mm (1/2")	A	DGPA401334__	DGPA401301__	DGPA4013__	Use 'DGMI4' for major diameter codes '02' & '25' 'DGI4' for all others (Page 6-1)	DGH34013__	DGS__YL	DGC14013	Screw: 2 each S7552	Wrench: W4025			
		B	DGPB401334__	DGPB401301__	DGPB4013__							DGS__XR		
		C	DGPC401334__	DGPC401301__	DGPC4013__							DGS__XL		
		D	DGPD401334__	DGPD401301__	DGPD4013__							DGS__YR		
	20mm (3/4")	A	DGPA402034__	DGPA402001__	DGPA4020__		DGH34020__	DGS__YL	DGC14020			Screw: 2 each S7552	Wrench: W4025	
		B	DGPB402034__	DGPB402001__	DGPB4020__									DGS__XR
		C	DGPC402034__	DGPC402001__	DGPC4020__									DGS__XL
		D	DGPD402034__	DGPD402001__	DGPD4020__									DGS__YR
5mm (.197")	13mm (1/2")	A	DGPA501334__	DGPA501301__	DGPA5013__	'DGI5'  (Page 6-1)	DGH35013__	DGS__YL	DGC15013	Screw: 2 each S7552	Wrench: W4025			
		B	DGPB501334__	DGPB501301__	DGPB5013__							DGS__XR		
		C	DGPC501334__	DGPC501301__	DGPC5013__							DGS__XL		
		D	DGPD501334__	DGPD501301__	DGPD5013__							DGS__YR		
	25mm (1")	A	DGPA502534__	DGPA502501__	DGPA5025__		DGH35025__	DGS__YL	DGC15025			Screw: 2 each S7552	Wrench: W4025	
		B	DGPB502534__	DGPB502501__	DGPB5025__									DGS__XR
		C	DGPC502534__	DGPC502501__	DGPC5025__									DGS__XL
		D	DGPD502534__	DGPD502501__	DGPD5025__									DGS__YR
6mm (.236")	13mm (1/2")	A	DGPA601334__	DGPA601301__	DGPA6013__	'DGI6'  (Page 6-1)	DGH36013__	DGS__YL	DGC16013	Screw: 2 each S7552	Wrench: W4025			
		B	DGPB601334__	DGPB601301__	DGPB6013__							DGS__XR		
		C	DGPC601334__	DGPC601301__	DGPC6013__							DGS__XL		
		D	DGPD601334__	DGPD601301__	DGPD6013__							DGS__YR		
	25mm (1")	A	DGPA602534__	DGPA602501__	DGPA6025__		DGH36025__	DGS__YL	DGC16025			Screw: 2 each S7552	Wrench: W4025	
		B	DGPB602534__	DGPB602501__	DGPB6025__									DGS__XR
		C	DGPC602534__	DGPC602501__	DGPC6025__									DGS__XL
		D	DGPD602534__	DGPD602501__	DGPD6025__									DGS__YR

**DEEPCUT  
FACE GROOVING**

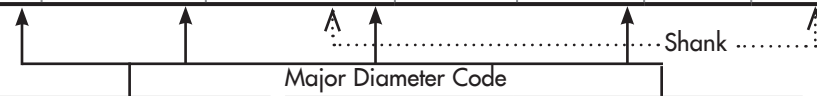

Major Diameter Range	Insert Width	Code	Insert Style
.787"-.885" (20-22.5mm)	2mm	02	DGI
	3 & 4mm	02	DGMI
.885"-.984" (22.5-25mm)	2mm	25	DGI
	3 & 4mm	25	DGMI
.984"-1.082" (25-27.5mm)	2mm	57	DGI
	3, 4, 5 & 6mm	23	DGI
1.082"-1.181" (27.5-30mm)	2mm	70	DGI
	3, 4, 5 & 6mm	23	DGI
1.181"-1.377" (30-35mm)	2mm	05	DGI
	3, 4, 5 & 6mm	34	DGI

Major Diameter Range	Insert Width	Code	Insert Style
1.377"-1.574" (35-40mm)	2mm	50	DGI
	3, 4, 5 & 6mm	34	DGI
1.574"-1.968" (40-50mm)	All	45	DGI
1.968"-2.362" (50-60mm)		56	DGI
2.362"-2.952" (60-75mm)		67	DGI
2.952"-3.937" (75-100mm)		71	DGI
3.937"-5.905" (100-150mm)		11	DGI
5.905"-11.811" (150-300mm)		13	DGI
11.811"-∞ (300mm-∞)	30	DGI	



**Note:**  
As long as first plunge is made within major diameter range and each following plunge overlaps, groove width can be increased toward or away from center of part.

## KAISER TOOL COMPANY, INC.

Phone: 888-THINBIT (888-844-6248) or (260) 484-3620 • Fax: 888-THINFAX (888-844-6329) or (260) 482-1881  
www.thinbit.com • General E-mail: thinbit@kaisertool.com • Orders: orders@thinbit.com • Quotes: quotes@thinbit.com

PRODUCT SELECTION GUIDE - BORING, PROFILING & TURNING

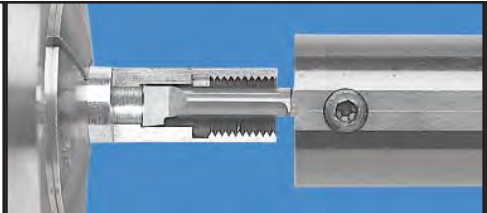
**BORING**

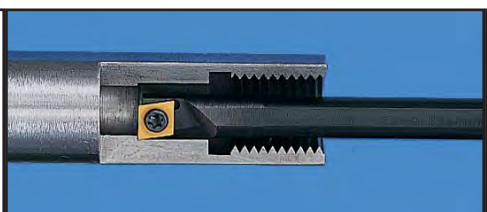
<p>PAGE 3-3</p>		<ul style="list-style-type: none"> <li>• Finish boring</li> <li>• For internal diameters of .073" and larger</li> <li>• Solid carbide shanks in 1/8", 3/16", 1/4", 5/16", 3/8" and 1/2" diameter</li> </ul>
<p>PAGE 3-5</p>		<ul style="list-style-type: none"> <li>• Profiling &amp; Reverse Profiling</li> <li>• For internal diameters of .125" and larger</li> <li>• Solid carbide shanks in 1/8", 3/16", 1/4", 5/16", 3/8" and 1/2" diameter</li> </ul>
<p>PAGE 3-7 to 3-10</p>		<ul style="list-style-type: none"> <li>• Rough boring using Trigon inserts</li> <li>• PAGE 3-8: .210" Min. Bore; MBE (WCGT) style</li> <li>• PAGE 3-9: .270" Min. Bore; MBF (WCGT) style</li> <li>• PAGE 3-10: .410" Min. Bore; MBG (WCGT) style</li> </ul>
<p>PAGE 3-11 to 3-18</p>		<ul style="list-style-type: none"> <li>• Finish boring</li> <li>• PAGE 3-12: .165" Min. Bore; MBZ style</li> <li>• PAGE 3-13: .180" Min. Bore; MBA (CD) style</li> <li>• PAGE 3-15: .270" Min. Bore; MBB (TD) style</li> <li>• PAGE 3-17: .430" Min. Bore; MBC (TP) style</li> </ul>



[www.thinbit.com/qr3-1](http://www.thinbit.com/qr3-1)

Scan this code  
for additional  
information

**THINBIT®**

OVER 100,000 TOOLS IN STOCK FOR  
GROOVING • THREADING • PARTING • BORING  
TURNING • FACE GROOVING  
SPECIALS • FORM TOOLS

**KAISER TOOL COMPANY, INC.**

Phone: 888-THINBIT (888-844-6248) or (260) 484-3620 • Fax: 888-THINFAX (888-844-6329) or (260) 482-1881  
www.thinbit.com • General E-mail: [thinbit@kaisertool.com](mailto:thinbit@kaisertool.com) • Orders: [orders@thinbit.com](mailto:orders@thinbit.com) • Quotes: [quotes@thinbit.com](mailto:quotes@thinbit.com)

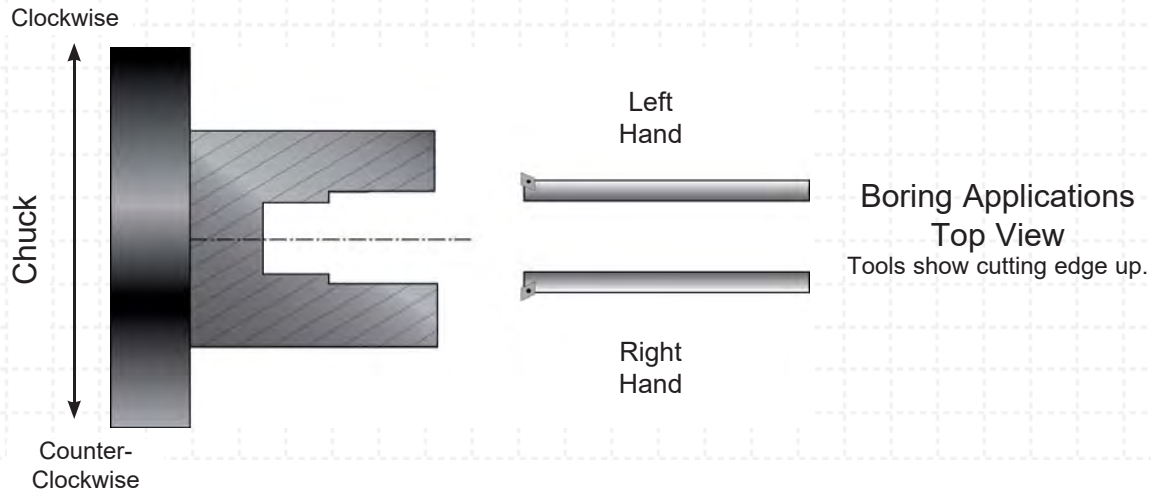

'K' ANGLE

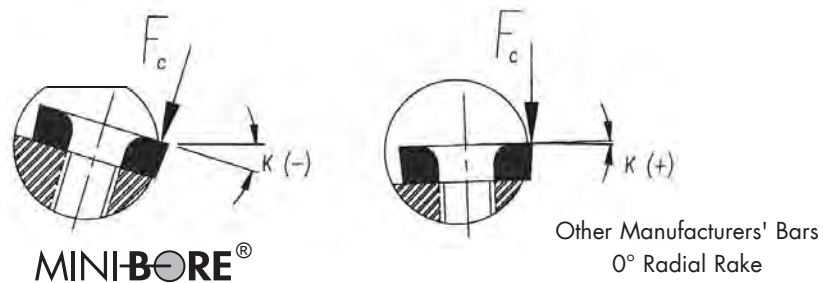

**MINI-BORE®** bars are designed to cut above center with a negative cutting rake or 'K' angle. As the diameter of the bar increases the 'K' angle decreases. Flats are provided to ensure speedy and proper set-up.

This unique design provides critical advantages over other manufacturers' small diameter bars:

- Up to 25% greater cross-sectional area under the cutting edge which increases the strength and rigidity of the pocket.
- Increased screw thread engagement to reduce thread stripping and increase the holding power.
- Better surface finishes due to better chip control and flow.

**KAISER TOOL COMPANY, INC.**

## PRODUCT INFORMATION

- For boring diameters .073" and larger.
- 1/8", 3/16", 1/4", 5/16", 3/8" and 1/2" shank.
- Elliptically ground necks for greater strength.
- Round necks to fit into small diameters.
- Sub-micron grain **DURA-MAX® 2000** Carbide.
- Tools available with TiN, TiAlN, TiCN and Diamond coating.

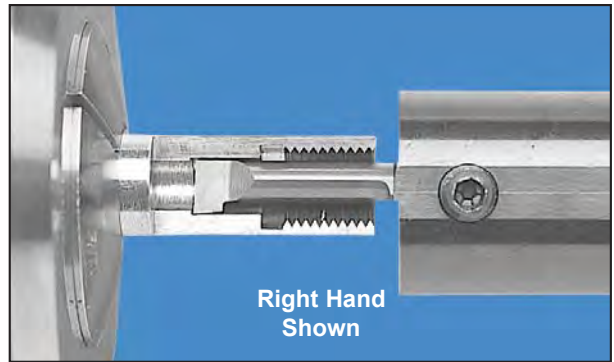

## MODIFICATIONS

SEE PAGE  
8-3  
FOR ADDITIONAL  
INFORMATION

<p><b>CUSTOM BLANK</b> (TOP VIEW)</p>	<p><b>RADI</b> (TOP VIEW)</p>	<p><b>LEAD ANGLE</b> (TOP VIEW)</p>	<p><b>BACK CLEARANCE</b> (TOP VIEW)</p>
	<p>PG 8-6</p>	<p><b>TOP RAKE</b> (SIDE VIEW)</p>	<p><b>CHIP BREAKER</b> (SIDE VIEW)</p>

## TOOLHOLDER SELECTIONS

### ADAPTER STYLES

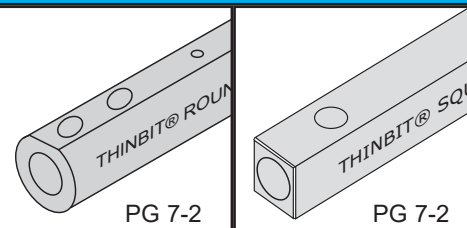

## TECHNICAL SECTIONS

PRODUCT DEMONSTRATION	SPEEDS AND FEEDS	APPLICATION REFERENCE	TROUBLESHOOTING
 <a href="http://www.thinbit.com/qr3-3">www.thinbit.com/qr3-3</a>	PG 9-15	PG 9-4	PG 9-7

## KAISER TOOL COMPANY, INC.

Phone: 888-THINBIT (888-844-6248) or (260) 484-3620 • Fax: 888-THINFAX (888-844-6329) or (260) 482-1881  
 www.thinbit.com • General E-mail: [thinbit@kaisertool.com](mailto:thinbit@kaisertool.com) • Orders: [orders@thinbit.com](mailto:orders@thinbit.com) • Quotes: [quotes@thinbit.com](mailto:quotes@thinbit.com)

# BORING TOOLS

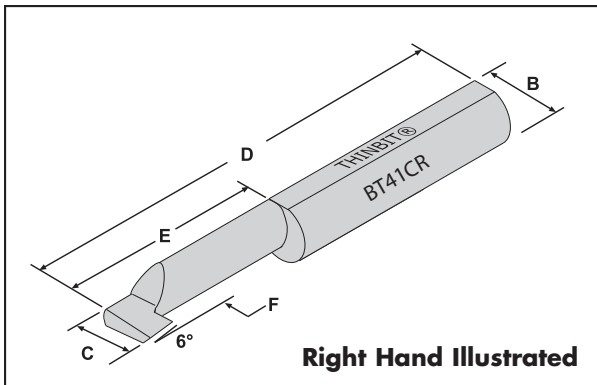

FRONT RAKE: Primary 21°  
 BACK CLEARANCE: 3° Lead side  
 SIDE CLEARANCE: 7° Lead side  
 LEAD ANGLE: 6°  
 RADIUS: None  
 TOP RAKE: 0°  
 NOTE: Tool designed for feeding into bore only.

## ORDERING INSTRUCTIONS

Select the **ORDER CODE** in the table below that represents your selection of tool dimensions.

**EXAMPLE:**

The **ORDER CODE** for a .250" minimum bore, right hand tool with a .875" tool reach and .062" projection is:  
**BT41CR**



TOOLS BORING







Specifications			Order Code						Information		
Minimum Bore	Tool Reach	Projection	DURA-MAX® 2000 Carbide See Page 9-15 for Speeds and Feeds		Coatings See Page 9-6 for expanded coating descriptions				Shank Diameter	Overall Length	Toolholder Page 7-2
'C'	'E'	'F'	Right Hand	Left Hand	TiN	TiCN	TiAlN	Diamond	'B'	'D'	Use Toolholders Beginning With
	Minimum	+ .000"/- .010"									
.073" Round Neck	.500"	.010"	BT21AR	BT21AL					1/8"	1.500"	'AD'
.125"	.500"	.031"	BT21CR	BT21CL							
.187"	.750"	.047"	BT31CR	BT31CL					3/16"	2.000"	'AD'
.250"	.875"	.062"	BT41CR	BT41CL	add 'C'	add 'D'	add 'E'	add 'F'	1/4"	2.500"	'AD'
.312"	1.156"	.078"	BT51CR	BT51CL					5/16"	2.500"	'AD'
.375"	1.437"	.125"	BT61CR	BT61CL					3/8"	3.000"	'AD'
.500"	2.000"	.167"	BT81CR	BT81CL					1/2"	3.500"	'AD'

## KAISER TOOL COMPANY, INC.

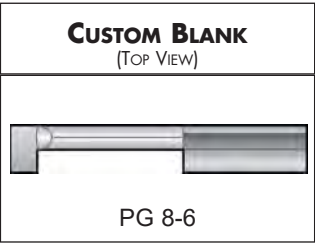
Phone: 888-THINBIT (888-844-6248) or (260) 484-3620 • Fax: 888-THINFAX (888-844-6329) or (260) 482-1881  
 www.thinbit.com • General E-mail: thinbit@kaisertool.com • Orders: orders@thinbit.com • Quotes: quotes@thinbit.com

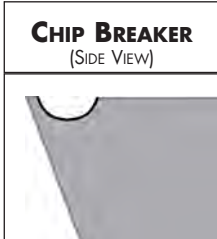

<b>PRODUCT INFORMATION</b>	<ul style="list-style-type: none"> <li>For profiling diameters .125" and larger.</li> <li>1/8", 3/16", 1/4", 5/16", 3/8" and 1/2" shank.</li> <li>Elliptically ground necks for greater strength.</li> <li>Sub-micron grain <b>DURA-MAX® 2000</b> Carbide.</li> <li>Tools available with TiN, TiAlN, TiCN and Diamond coating.</li> </ul>	<b>Right Hand Profiling Tool Shown</b>	
	<b>Right Hand Reverse Profiling Tool Shown</b>		

<b>MODIFICATIONS</b> SEE PAGE 8-3 FOR ADDITIONAL INFORMATION	<b>CUSTOM BLANK</b> (TOP VIEW)	<b>RADI</b> (TOP VIEW)	<b>LEAD ANGLE</b> (TOP VIEW)	<b>BACK CLEARANCE</b> (TOP VIEW)
	 PG 8-6			
		<b>TOP RAKE</b> (SIDE VIEW)	<b>CHIP BREAKER</b> (SIDE VIEW)	<b>SIDE CLEARANCE</b> (END VIEW)
				

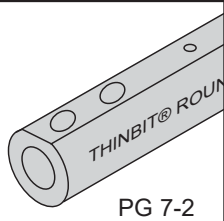
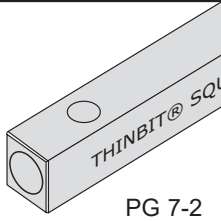
<b>TOOLHOLDER SELECTIONS</b>	<b>ADAPTER STYLES</b>	
	 PG 7-2	 PG 7-2

<b>TECHNICAL SECTIONS</b>	<b>PRODUCT DEMONSTRATION</b>	<b>SPEEDS AND FEEDS</b>	<b>APPLICATION REFERENCE</b>	<b>TROUBLESHOOTING</b>
	 <a href="http://www.thinbit.com/qr3-5">www.thinbit.com/qr3-5</a>	PG 9-15	PG 9-4	PG 9-7

## ORDERING INSTRUCTIONS

Select the **ORDER CODE** in the table on the next page that represents your selection of tool dimensions.

**EXAMPLE:**

The **ORDER CODE** for a .375" minimum bore, right hand tool with a 1.350" tool reach and .125" projection is:  
**PT61CR**

### KAISER TOOL COMPANY, INC.

# PROFILING & REVERSE PROFILING TOOLS

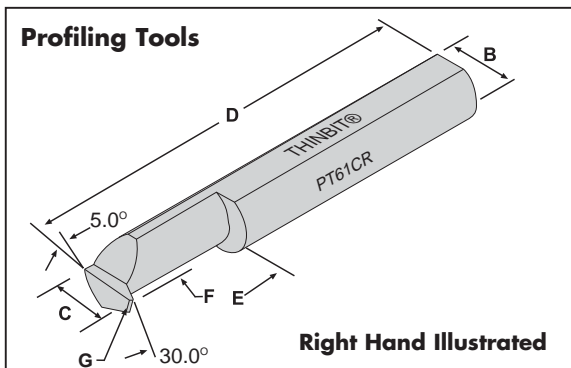

FRONT RAKE: Primary 21°  
 SIDE CLEARANCE: 5° Lead side  
 BACK CLEARANCE: 5° Lead side  
 BACK CLEARANCE: 30° Trailing side  
 NOTE: Tool designed for feeding into bore only.

SPECIFICATIONS				ORDER CODE				INFORMATION				
Minimum Bore	Tool Reach	Nose Radius	Projection	DURA-MAX® 2000 Carbide See Page 9-15 for Speeds and Feeds		Coatings See Page 9-6 for expanded coating descriptions Use uncoated part number and add coating code				Shank Diameter	Overall Length	Toolholder Page 7-2
'C'	'E'	'G'	'F'	Right Hand	Left Hand	TiN	TiCN	TiAlN	Diamond	'B'	'D'	Use Toolholders Beginning With
	Minimum		Minimum									
.125"	.425"	.007"	.052"	PT21BR	PT21BL	add 'C'	add 'D'	add 'E'	add 'F'	1/8"	1.500"	'AD'
.187"	.705"	.010"	.083"	PT31BR	PT31BL					3/16"	2.000"	'AD'
.250"	.840"	.010"	.115"	PT41BR	PT41BL					1/4"	2.500"	'AD'
.312"	1.115"	.015"	.146"	PT51BR	PT51BL					5/16"	2.500"	'AD'
.375"	1.350"	.015"	.115"	PT61CR	PT61CL					3/8"	3.000"	'AD'
.500"	1.870"	.015"	.157"	PT81CR	PT81CL					1/2"	3.500"	'AD'

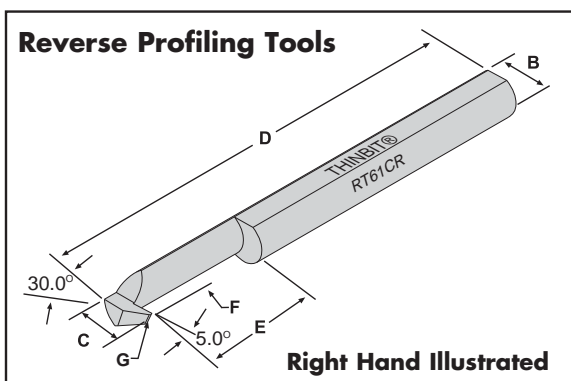

FRONT RAKE: Primary 21°  
 SIDE CLEARANCE: 10° Lead side  
 BACK CLEARANCE: 30° Lead side  
 BACK CLEARANCE: 5° Trailing side  
 NOTE: Tool designed for feeding out of bore only.

SPECIFICATIONS				ORDER CODE				INFORMATION				
Minimum Bore	Tool Reach	Nose Radius	Projection	DURA-MAX® 2000 Carbide See Page 9-15 for Speeds and Feeds		Coatings See Page 9-6 for expanded coating descriptions Use uncoated part number and add coating code				Shank Diameter	Overall Length	Toolholder Page 7-2
'C'	'E'	'G'	'F'	Right Hand	Left Hand	TiN	TiCN	TiAlN	Diamond	'B'	'D'	Use Toolholders Beginning With
	Minimum		Minimum									
.125"	.375"	.007"	.052"	RT21BR	RT21BL	add 'C'	add 'D'	add 'E'	add 'F'	1/8"	1.500"	'AD'
.187"	.625"	.010"	.083"	RT31BR	RT31BL					3/16"	2.000"	'AD'
.250"	.750"	.010"	.115"	RT41BR	RT41BL					1/4"	2.500"	'AD'
.312"	1.000"	.015"	.146"	RT51BR	RT51BL					5/16"	2.500"	'AD'
.375"	1.250"	.015"	.115"	RT61CR	RT61CL					3/8"	3.000"	'AD'
.500"	1.750"	.015"	.157"	RT81CR	RT81CL					1/2"	3.500"	'AD'

## KAISER TOOL COMPANY, INC.

Phone: 888-THINBIT (888-844-6248) or (260) 484-3620 • Fax: 888-THINFAX (888-844-6329) or (260) 482-1881  
 www.thinbit.com • General E-mail: thinbit@kaisertool.com • Orders: orders@thinbit.com • Quotes: quotes@thinbit.com

PROFILING

## PRODUCT INFORMATION

- Boring with .210" minimum bore diameter.
- 'K' angle increases strength in insert pocket by increasing the cross-sectional area below the insert.
- Boring bars for WCGT insert style.
- Variety of diameters made from Steel, Heavy Metal and Carbide.
- Bars and inserts are compatible with other ANSI standard bars and inserts. Call for cross-overs.
- Sub-micron grain **DURA-MAX® 4000** and **5000** Carbide.
- Tools available with TiN, TiAlN, TiCN and Diamond coating.
- Modifications can be provided on any of our tooling. Please contact us with your application requirements.

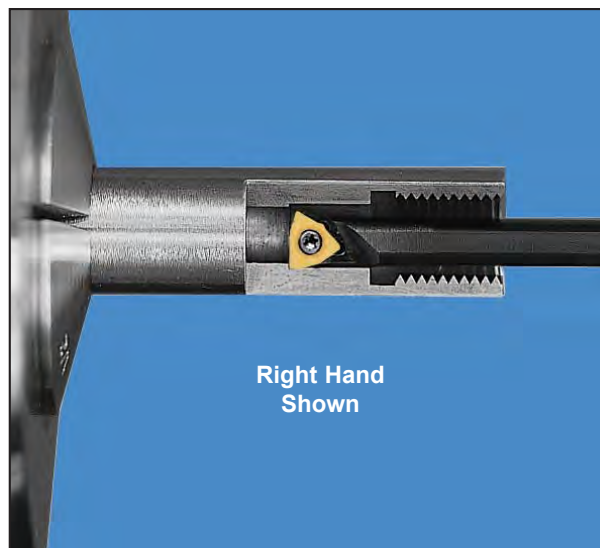

Right Hand Shown

## TOOLHOLDER SELECTIONS

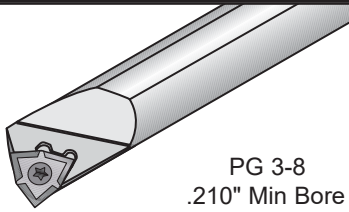
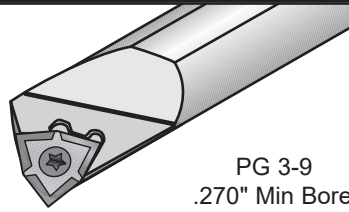
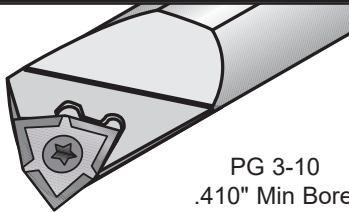
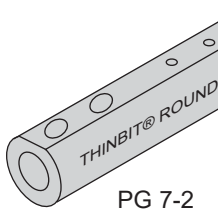
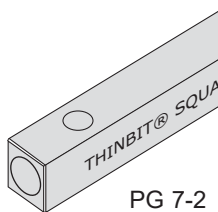
WCGT STYLE - MBE SERIES	WCGT STYLE - MBF SERIES	WCGT STYLE - MBG SERIES
 PG 3-8 .210" Min Bore	 PG 3-9 .270" Min Bore	 PG 3-10 .410" Min Bore
<b>ADAPTER STYLES</b>		
 PG 7-2		 PG 7-2

## INSERT SELECTIONS

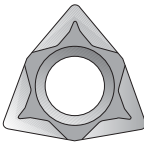
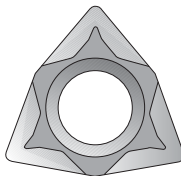
WCGT STYLE - MBE SERIES	WCGT STYLE - MBF SERIES	WCGT STYLE - MBG SERIES
 WCGT 1.21      PG 3-8	 WCGT 1.51.5      PG 3-9	 WCGT 21.5      PG 3-10

## TECHNICAL SECTIONS

PRODUCT DEMONSTRATION	SPEEDS AND FEEDS	APPLICATION REFERENCE	TROUBLESHOOTING
 <a href="http://www.thinbit.com/qr3-7">www.thinbit.com/qr3-7</a>	PG 9-14	PG 9-4	PG 9-7

## KAISER TOOL COMPANY, INC.

## TO ORDER WCGT STYLE - MBE SERIES BORING BARS

Select the **ORDER CODE** in the table below that represents your selection of tool specifications.

**EXAMPLE:**

The **ORDER CODE** for a .270" minimum bore, right hand, heavy metal shank with a 3° lead angle is:  
**MBEH132527R**

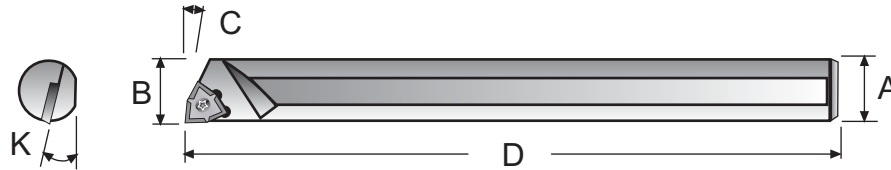

 Minimum Bore 'B' With .008" radius insert	TOOL SPECIFICATIONS						ORDER CODE		
	Material	Bar Diameter 'A'	Length 'D'	Lead Angle 'C'	'K' Angle 'K' see page 3-2	Boring Bar Includes Screw and Wrench	Replacement Parts		
	Extension Ratios: Steel: 4 x ø Heavy Metal: 6 x ø Carbide: 8 x ø						Screw	Wrench	
Right Hand Bars  Use inserts beginning with 'MBEIW' and ANSI 'WCGT 1.21' inserts	.210"	Steel	.188"	3.500"	3°	17°	MBES131821R	F15	W11
		Heavy Metal	.188"	3.976"	3°	17°	MBEH131821R	F15	W11
		Carbide	.188"	4.474"	3°	17°	MBEC131821R	F15	W11
	.220"	Steel	.188"	3.500"	0°	17°	MBES101822R	F15	W11
		Heavy Metal	.188"	3.976"	0°	17°	MBEH101822R	F15	W11
	.270"	Steel	.250"	4.000"	0°	12°	MBES102527R	F15	W11
					3°	12°	MBES132527R	F15	W11
		Heavy Metal	.250"	3.976"	0°	12°	MBEH102527R	F15	W11
					3°	12°	MBEH132527R	F15	W11
	Left Hand Bars Use inserts beginning with 'MBEIW' and ANSI 'WCGT 1.21' inserts	.210"	Steel	.188"	3.500"	3°	17°	MBES131821L	F15
Heavy Metal			.188"	3.976"	3°	17°	MBEH131821L	F15	W11
.270"		Steel	.250"	4.000"	3°	12°	MBES132527L	F15	W11
		Heavy Metal	.250"	3.976"	3°	12°	MBEH132527L	F15	W11

**MBE TRIGON BORING**

## TO ORDER WCGT STYLE - MBE SERIES INSERTS

Select the **ORDER CODE** in the table below that represents your selection of insert specifications.

**EXAMPLE:**

The **ORDER CODE** for a **DURA-MAX® 4000** insert with .008" radius and TiN coating is:  
**MBEIW08D4C**

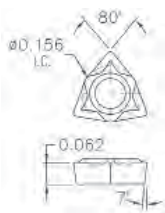
WCGT Style MBE Series Use toolholders beginning with 'MBE'	SPECIFICATIONS		ORDER CODE			
	Insert Material	Corner Radius	Coating See Page 9-5 for expanded material description and Page 9-14 for speeds and feeds			
			Uncoated	TiN	TiCN Non-stock	TiAlN Non-stock
	<b>DURA-MAX® 4000 carbide</b> For Steel & Interrupted Cutting	.004"	MBEIW04D4U	MBEIW04D4C	MBEIW04D4D	MBEIW04D4E
		.008"	MBEIW08D4U	MBEIW08D4C	MBEIW08D4D	MBEIW08D4E
		.015"	MBEIW15D4U	MBEIW15D4C	MBEIW15D4D	MBEIW15D4E
<b>DURA-MAX® 5000 carbide</b> For Aluminum & Nonferrous	.004"	MBEIW04D5U	MBEIW04D5C	MBEIW04D5D	MBEIW04D5E	
	.008"	MBEIW08D5U	MBEIW08D5C	MBEIW08D5D	MBEIW08D5E	
	.015"	MBEIW15D5U	MBEIW15D5C	MBEIW15D5D	MBEIW15D5E	

### KAISER TOOL COMPANY, INC.

## TO ORDER WCGT STYLE - MBF SERIES BORING BARS

Select the **ORDER CODE** in the table below that represents your selection of tool specifications.

### EXAMPLE:

The **ORDER CODE** for a .330" minimum bore, right hand, heavy metal shank with a 0° lead angle is:

**MBFH103133R**

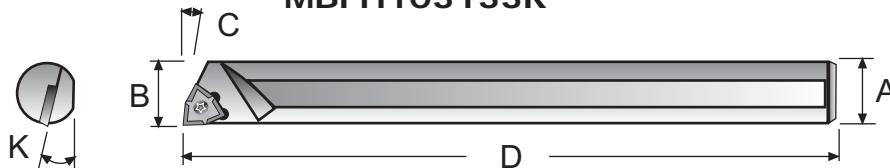

 .187" I.C.	TOOL SPECIFICATIONS						ORDER CODE		
	Minimum Bore 'B' <small>With .008" radius insert</small>	Material <small>Extension Ratios: Steel: 4 x ø Heavy Metal: 6 x ø Carbide: 8 x ø</small>	Bar Diameter 'A'	Length 'D'	Lead Angle 'C'	'K' Angle 'K' <small>See Page 3-2</small>	Boring Bar  Includes Screw and Wrench	Screw	Wrench
Right Hand Bars  Use inserts beginning with 'MBFIW' and ANSI 'WCGT 1.51.5' inserts	.270"	Steel	.250"	4.000"	0°	15°	MBFS102527R	F15	W11
					3°	15°	MBFS132527R	F15	W11
		Heavy Metal	.250"	3.976"	0°	15°	MBFH102527R	F15	W11
					3°	15°	MBFH132527R	F15	W11
	.330"	Steel	.312"	4.000"	0°	15°	MBFS103133R	F15	W11
					3°	15°	MBFS133133R	F15	W11
		Heavy Metal	.312"	5.500"	0°	15°	MBFH103133R	F15	W11
					3°	15°	MBFH133133R	F15	W11
Left Hand Bars Use inserts beginning with 'MBFIW' and ANSI 'WCGT 1.51.5' inserts	.270"	Steel	.250"	4.000"	3°	15°	MBFS132527L	F15	W11
		Heavy Metal	.250"	3.976"	3°	15°	MBFH132527L	F15	W11
	.330"	Steel	.312"	4.000"	3°	15°	MBFS133133L	F15	W11
		Heavy Metal	.312"	5.500"	3°	15°	MBFH133133L	F15	W11

## TO ORDER WCGT STYLE - MBF SERIES INSERTS

Select the **ORDER CODE** in the table below that represents your selection of insert specifications.

### EXAMPLE:

The **ORDER CODE** for a **DURA-MAX® 4000** insert with .008" radius and TiN coating is:

**MBFIW08D4C**

WCGT Style MBF Series Use toolholders beginning with 'MBF'	SPECIFICATIONS		ORDER CODE			
	Insert Material	Corner Radius	Coating <small>See Page 9-5 for expanded material description and Page 9-14 for Speeds and Feeds</small>			
			Uncoated	TiN	TiCN <small>Non-stock</small>	TiAlN <small>Non-stock</small>
	<b>DURA-MAX® 4000 carbide</b> <small>For Steel &amp; Interrupted Cutting</small>	.004"	MBFIW04D4U	MBFIW04D4C	MBFIW04D4D	MBFIW04D4E
		.008"	MBFIW08D4U	MBFIW08D4C	MBFIW08D4D	MBFIW08D4E
		.015"	MBFIW15D4U	MBFIW15D4C	MBFIW15D4D	MBFIW15D4E
	<b>DURA-MAX® 5000 carbide</b> <small>For Aluminum &amp; Nonferrous</small>	.004"	MBFIW04D5U	MBFIW04D5C	MBFIW04D5D	MBFIW04D5E
		.008"	MBFIW08D5U	MBFIW08D5C	MBFIW08D5D	MBFIW08D5E
		.015"	MBFIW15D5U	MBFIW15D5C	MBFIW15D5D	MBFIW15D5E

## KAISER TOOL COMPANY, INC.

Phone: 888-THINBIT (888-844-6248) or (260) 484-3620 • Fax: 888-THINFAX (888-844-6329) or (260) 482-1881  
 www.thinbit.com • General E-mail: [thinbit@kaisertool.com](mailto:thinbit@kaisertool.com) • Orders: [orders@thinbit.com](mailto:orders@thinbit.com) • Quotes: [quotes@thinbit.com](mailto:quotes@thinbit.com)



## TO ORDER WCGT STYLE - MBG SERIES BORING BARS

Select the **ORDER CODE** in the table below that represents your selection of tool specifications.

**EXAMPLE:**

The **ORDER CODE** for a .410" minimum bore, right hand, heavy metal shank with a 3° lead angle is:  
**MBGH133741R**

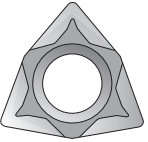

 .250" I.C.	TOOL SPECIFICATIONS						ORDER CODE		
	Minimum Bore 'B'	Material	Bar Diameter 'A'	Length 'D'	Lead Angle 'C'	'K' Angle 'K'	Boring Bar Includes Screw and Wrench	Replacement Parts	
	With .008" radius insert	Extension Ratios: Steel: 4 x ø Heavy Metal: 6 x ø Carbide: 8 x ø				See Page 3-2		Screw	Wrench
Right Hand Bars  Use inserts beginning with 'MBGIW' and ANSI 'WCGT 21.5' inserts	.410"	Steel	.375"	5.500"	0°	8°	MBGS103741R	F26	W26
					3°	8°	MBGS133741R	F26	W26
		Heavy Metal	.375"	5.500"	0°	8°	MBGH103741R	F26	W26
					3°	8°	MBGH133741R	F26	W26
	.530"	Steel	.500"	5.500"	0°	8°	MBGS105053R	F26	W26
					3°	8°	MBGS135053R	F26	W26
		Heavy Metal	.500"	5.500"	0°	8°	MBGH105053R	F26	W26
					3°	8°	MBGH135053R	F26	W26
Left Hand Bars  Use inserts beginning with 'MBGIW' and ANSI 'WCGT 21.5' inserts	.410"	Steel	.375"	5.500"	3°	8°	MBGS133741L	F26	W26
		Heavy Metal	.375"	5.500"	3°	8°	MBGH133741L	F26	W26
	.530"	Steel	.500"	5.500"	3°	8°	MBGS135053L	F26	W26
		Heavy Metal	.500"	5.500"	3°	8°	MBGH135053L	F26	W26

**MBF & MBG TRIGON BORING**

## TO ORDER WCGT STYLE - MBG SERIES INSERTS

Select the **ORDER CODE** in the table below that represents your selection of insert specifications.

**EXAMPLE:**

The **ORDER CODE** for a **DURA-MAX® 4000** insert with .008" radius and TiN coating is:  
**MBGIW08D4C**

WCGT Style MBG Series Use toolholders beginning with 'MBG'	SPECIFICATIONS		ORDER CODE			
	Insert Material	Corner Radius	Coating See Page 9-5 for expanded material description and Page 9-14 for Speeds and Feeds			
			Uncoated	TiN	TiCN Non-stock	TiAlN Non-stock
	<b>DURA-MAX® 4000 carbide</b> For Steel & Interrupted Cutting	.004"	MBGIW04D4U	MBGIW04D4C	MBGIW04D4D	MBGIW04D4E
		.008"	MBGIW08D4U	MBGIW08D4C	MBGIW08D4D	MBGIW08D4E
		.015"	MBGIW15D4U	MBGIW15D4C	MBGIW15D4D	MBGIW15D4E
	<b>DURA-MAX® 5000 carbide</b> For Aluminum & Nonferrous	.004"	MBGIW04D5U	MBGIW04D5C	MBGIW04D5D	MBGIW04D5E
		.008"	MBGIW08D5U	MBGIW08D5C	MBGIW08D5D	MBGIW08D5E
		.015"	MBGIW15D5U	MBGIW15D5C	MBGIW15D5D	MBGIW15D5E

## KAISER TOOL COMPANY, INC.

## PRODUCT INFORMATION

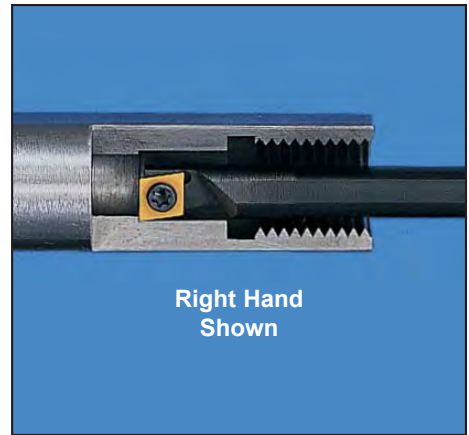

- Boring with .165" minimum bore diameter.
- 'K' angle increases strength in insert pocket by increasing the cross-sectional area below the insert.
- Boring bars for CD, TD and TP insert styles.
- Variety of diameters made from Steel, Heavy Metal and Carbide.
- Sub-micron grain **DURA-MAX® 3000, 4000 and 5000** Carbides.
- CBN tipped **DURA-MAX® 8000**.
- PCD tipped **DURA-MAX® 9000**.
- Inserts available with TiN, TiAlN, TiCN and Diamond coating.
- Bars and inserts are completely compatible with other ANSI standard bars and inserts. Call for cross-overs.
- Modifications can be provided on any of our tooling. Please contact us with your application requirements.

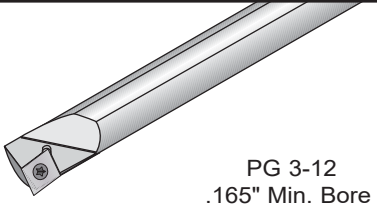
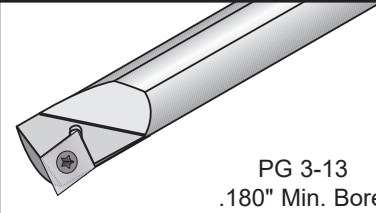
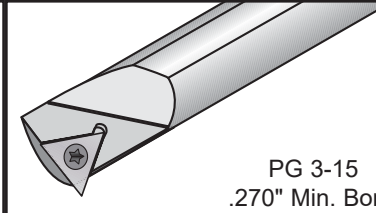
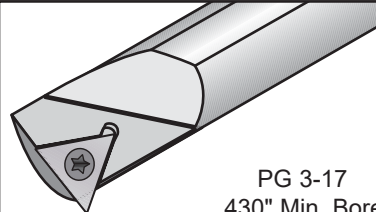
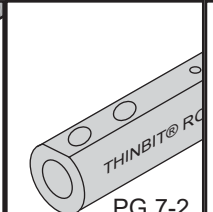

## TOOLHOLDER SELECTIONS

CD STYLE - MBZ SERIES	CD STYLE - MBA SERIES	TD STYLE - MBB SERIES
 PG 3-12 .165" Min. Bore	 PG 3-13 .180" Min. Bore	 PG 3-15 .270" Min. Bore
	TP STYLE - MBC SERIES	ADAPTER STYLES
	 PG 3-17 .430" Min. Bore	 PG 7-2

## INSERT SELECTIONS

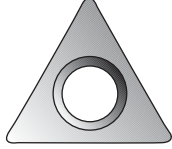
CD STYLE - MBA SERIES	TD STYLE - MBB SERIES	TP STYLE - MBC SERIES
 PG 3-14	 PG 3-16	 PG 3-18

## TECHNICAL SECTIONS

PRODUCT DEMONSTRATION	SPEEDS AND FEEDS	APPLICATION REFERENCE	TROUBLESHOOTING
 <a href="http://www.thinbit.com/qr3-11">www.thinbit.com/qr3-11</a>	PG 9-15	PG 9-4	PG 9-7

## KAISER TOOL COMPANY, INC.

## TO ORDER CD STYLE - MBZ SERIES BORING BARS

Select the **ORDER CODE** in the table below that represents your selection of tool specifications.

**EXAMPLE:**

The **ORDER CODE** for a .165" minimum bore, right hand, steel, .187" shank is:  
**MBZS171816R**

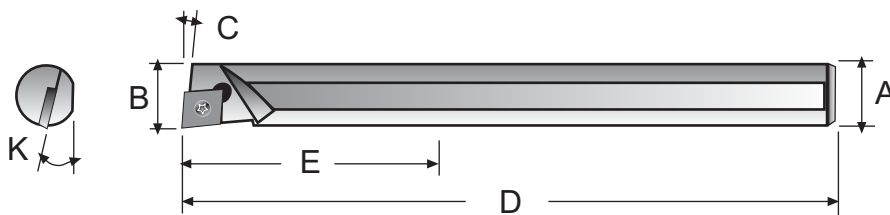

	TOOL SPECIFICATIONS							ORDER CODE		
	Minimum Bore 'B'  With .007" radius insert	Material  Extension Ratios: Steel: 4 x ø Carbide: 8 x ø	Bar Diameter 'A'	Length 'D'	Neck Length 'E'	Lead Angle 'C'	'K' Angle 'K'	Boring Bar  Includes Screw and Wrench	Replacement Parts	
									Screw	Wrench
 Right Hand Bars Use inserts beginning with 'MBZIZ'	0.165"	Steel	.187"	2.500"	.580"	7°	17°	MBZS171816R	F11	W11
		Carbide	.156"	4.477"	1.500"	7°	17°	MBZC171516R		

**MBZ BARS & INSERTS BORING**

## TO ORDER CDCD STYLE - MBZ SERIES INSERTS

Select the **ORDER CODE** in the table below that represents your selection of insert specifications.

**EXAMPLE:**

The **ORDER CODE** for a **DURA-MAX® 5000** insert with .007" radius and TiN coating is:  
**MBZIZ07D5C**

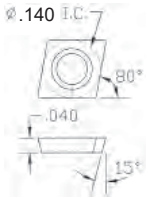
MBZ Series Use toolholders beginning with 'MBZ'	SPECIFICATIONS		ORDER CODE				
	Insert Material	Corner Radius	Coating <small>See Page 9-5 for expanded material description and Page 9-15 for speeds and feeds</small>				
			Uncoated	TiN	TiCN Non-stock	TiAlN Non-stock	Diamond Non-stock
	<b>DURA-MAX® 4000 carbide</b> For Steel & Interrupted Cutting	.002"	MBZIZ02D4U	MBZIZ02D4C	MBZIZ02D4D	MBZIZ02D4E	MBZIZ02D4F
		.007"	MBZIZ07D4U	MBZIZ07D4C	MBZIZ07D4D	MBZIZ07D4E	MBZIZ07D4F
		.015"	MBZIZ15D4U	MBZIZ15D4C	MBZIZ15D4D	MBZIZ15D4E	MBZIZ15D4F
	<b>DURA-MAX® 5000 carbide</b> For Aluminum & Nonferrous	.002"	MBZIZ02D5U	MBZIZ02D5C	MBZIZ02D5D	MBZIZ02D5E	MBZIZ02D5F
		.007"	MBZIZ07D5U	MBZIZ07D5C	MBZIZ07D5D	MBZIZ07D5E	MBZIZ07D5F
		.015"	MBZIZ15D5U	MBZIZ15D5C	MBZIZ15D5D	MBZIZ15D5E	MBZIZ15D5F

### KAISER TOOL COMPANY, INC.

# TO ORDER CD STYLE - MBA SERIES BORING BARS

Select the **ORDER CODE** in the table below that represents your selection of tool specifications.

### EXAMPLE:

The **ORDER CODE** for a .205" minimum bore, right hand, steel, .187" shank is:  
**MBAS151820R**

STANDARD BARS



STEP BARS

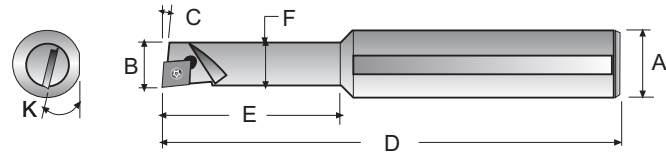

 .156" I.C.	TOOL SPECIFICATIONS								ORDER CODE			
	Minimum Bore 'B'  With .007" radius insert	Material  Extension Ratios: Steel: 4 x ø Heavy Metal: 6 x ø Carbide: 8 x ø	Bar Diameter		Length		Lead Angle 'C'	'K' Angle 'K'  See Page 3-2	Boring Bar  Includes Screw and Wrench	Replacement Parts		
			'F' Neck	'A' Shank	'E' Neck	'D' Overall				Screw	Wrench	
Right Hand Bars  Use inserts beginning with 'MBAIW', 'MBAIZ', left hand 'MBAIG' inserts and most ANSI 'CD' standard inserts	.180"	Steel	.164"	.187"	.520"	2.500"	7°	17°	MBAS171818R			
			.164"	.375"	.500"	2.500"	7°	17°	MBAS373718R050			
		Heavy Metal	.156"		---	3.976"	7°	17°	MBAH171518R			
			.164"	.500"	.750"	3.000"	7°	17°	MBAH375018R075			
	Carbide	.156"		---	4.477"	7°	17°	MBAC171518R				
		.205"	Steel	.187"		---	3.500"	5°	17°	MBAS151820R		
	.180"			.500"	.500"	3.000"	5°	17°	MBAS355020R050			
	Heavy Metal	.187"		---	3.976"	5°	17°	MBAH151820R				
		.210"	Steel	.187"		---	3.500"	0°	17°	MBAS101821R		
	.187"			.375"	1.000"	3.000"	5°	17°	MBAS353721R100			
	Heavy Metal	.187"		---	3.976"	0°	17°	MBAH101821R				
		.220"	Steel	.197"	.375"	.500"	2.500"	0°	17°	MBAS303722R050		
	.187"			---	3.976"	5°	17°	MBAH151822R				
	.187"		.500"	1.125"	3.977"	5°	17°	MBAH355022R112				
	Heavy Metal	.187"		---	4.477"	5°	17°	MBAC151822R				
		.230"	Steel	.187"		---	3.500"	5°	17°	MBAS151823R		
.250"				---	4.000"	0°	12°	MBAS102527R				
.280"	Steel	.250"		---	4.000"	5°	12°	MBAS152528R				
		.250"	.375"	1.250"	3.000"	5°	12°	MBAS353728R125				
	Heavy Metal	.250"		---	3.976"	5°	12°	MBAH152528R				
		.250"		---	6.504"	5°	12°	MBAC152528R				
.350"	Heavy Metal	.313"		---	5.500"	5°	8°	MBAH153135R				
		.180"	Steel	.164"	.187"	.520"	2.500"	7°	17°	MBAS171818L		
Heavy Metal	.156"			---	3.976"	7°	17°	MBAH171518L				
	.205"	Steel	.180"	.500"	.500"	3.000"	5°	17°	MBAS355020L050			
.230"			Steel	.187"		---	3.500"	5°	17°	MBAS151823L		
				.250"		---	4.000"	5°	12°	MBAS152528L		
.280"	Steel	.250"		---	4.000"	5°	12°	MBAS152528L				

## KAISER TOOL COMPANY, INC.



Phone: 888-THINBIT (888-844-6248) or (260) 484-3620 • Fax: 888-THINFAX (888-844-6329) or (260) 482-1881  
www.thinbit.com • General E-mail: thinbit@kaisertool.com • Orders: orders@thinbit.com • Quotes: quotes@thinbit.com

# TO ORDER CD STYLE - MBA SERIES INSERTS

Select the **ORDER CODE** in the table below that represents your selection of insert specifications.

**EXAMPLE:**

The **ORDER CODE** for a molded chipbreaker, **DURA-MAX® 4000** insert with .007" radius and TiN coating is:  
**MBAIW07D4C**

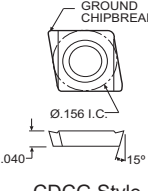
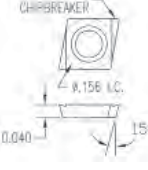
CD Style MBA Series Use toolholders beginning with 'MBA'	SPECIFICATIONS		ORDER CODE					
	Insert Material	Corner Radius	Coating <small>See Page 9-5 for expanded material descriptions and Page 9-15 for Speeds and Feeds</small>					
			Uncoated	TiN	TiCN Non-stock	TiAlN Non-stock	Diamond Non-stock	
Flat top    CDCD Style	<b>DURA-MAX® 4000</b> Carbide For Steel & Interrupted Cutting	.002"	MBAIZ02D4U	MBAIZ02D4C	MBAIZ02D4D	MBAIZ02D4E	MBAIZ02D4F	
		.007"	MBAIZ07D4U	MBAIZ07D4C	MBAIZ07D4D	MBAIZ07D4E	MBAIZ07D4F	
		.015"	MBAIZ15D4U	MBAIZ15D4C	MBAIZ15D4D	MBAIZ15D4E	MBAIZ15D4F	
	<b>DURA-MAX® 5000</b> Carbide For Aluminum & Nonferrous	.002"	MBAIZ02D5U	MBAIZ02D5C	MBAIZ02D5D	MBAIZ02D5E	MBAIZ02D5F	
		.007"	MBAIZ07D5U	MBAIZ07D5C	MBAIZ07D5D	MBAIZ07D5E	MBAIZ07D5F	
		.015"	MBAIZ15D5U	MBAIZ15D5C	MBAIZ15D5D	MBAIZ15D5E	MBAIZ15D5F	
	<b>DURA-MAX® 8000</b> CBN For Hardened Materials	.002"	MBAIZ02D8					
		.007"	MBAIZ07D8					
		.015"	MBAIZ15D8					
	<b>DURA-MAX® 9000</b> PCD For Abrasive Nonferrous	.002"	MBAIZ02D9					
		.007"	MBAIZ07D9					
		.015"	MBAIZ15D9					
Molded Chipbreaker    CDCH Style	<b>DURA-MAX® 4000</b> Carbide For Steel & Interrupted Cutting	.007"	MBAIW07D4U	MBAIW07D4C	MBAIW07D4D	MBAIW07D4E	MBAIW07D4F	
		.015"	MBAIW15D4U	MBAIW15D4C	MBAIW15D4D	MBAIW15D4E	MBAIW15D4F	
	<b>DURA-MAX® 5000</b> Carbide For Aluminum & Nonferrous	.007"	MBAIW07D5U	MBAIW07D5C	MBAIW07D5D	MBAIW07D5E	MBAIW07D5F	
		.015"	MBAIW15D5U	MBAIW15D5C	MBAIW15D5D	MBAIW15D5E	MBAIW15D5F	
Ground Chipbreaker Right Hand for Left Hand Bars    CDCG Style	<b>DURA-MAX® 4000</b> Carbide For Steel & Interrupted Cutting	.002"	MBAIG02D4UR	MBAIG02D4CR	MBAIG02D4DR	MBAIG02D4ER	MBAIG02D4FR	
		.007"	MBAIG07D4UR	MBAIG07D4CR	MBAIG07D4DR	MBAIG07D4ER	MBAIG07D4FR	
		.015"	MBAIG15D4UR	MBAIG15D4CR	MBAIG15D4DR	MBAIG15D4ER	MBAIG15D4FR	
	<b>DURA-MAX® 5000</b> Carbide For Aluminum & Nonferrous	.002"	MBAIG02D5UR	MBAIG02D5CR	MBAIG02D5DR	MBAIG02D5ER	MBAIG02D5FR	
		.007"	MBAIG07D5UR	MBAIG07D5CR	MBAIG07D5DR	MBAIG07D5ER	MBAIG07D5FR	
		.015"	MBAIG15D5UR	MBAIG15D5CR	MBAIG15D5DR	MBAIG15D5ER	MBAIG15D5FR	
Ground Chipbreaker Left Hand for Right Hand Bars    CDCG Style	<b>DURA-MAX® 4000</b> Carbide For Steel & Interrupted Cutting	.002"	MBAIG02D4UL	MBAIG02D4CL	MBAIG02D4DL	MBAIG02D4EL	MBAIG02D4FL	
		.007"	MBAIG07D4UL	MBAIG07D4CL	MBAIG07D4DL	MBAIG07D4EL	MBAIG07D4FL	
		.015"	MBAIG15D4UL	MBAIG15D4CL	MBAIG15D4DL	MBAIG15D4EL	MBAIG15D4FL	
	<b>DURA-MAX® 5000</b> Carbide For Aluminum & Nonferrous	.002"	MBAIG02D5UL	MBAIG02D5CL	MBAIG02D5DL	MBAIG02D5EL	MBAIG02D5FL	
		.007"	MBAIG07D5UL	MBAIG07D5CL	MBAIG07D5DL	MBAIG07D5EL	MBAIG07D5FL	
		.015"	MBAIG15D5UL	MBAIG15D5CL	MBAIG15D5DL	MBAIG15D5EL	MBAIG15D5FL	

**MBA BARS  
& INSERTS  
BORING**

## KAISER TOOL COMPANY, INC.

Phone: 888-THINBIT (888-844-6248) or (260) 484-3620 • Fax: 888-THINFAX (888-844-6329) or (260) 482-1881  
www.thinbit.com • General E-mail: thinbit@kaisertool.com • Orders: orders@thinbit.com • Quotes: quotes@thinbit.com





# TO ORDER TD STYLE - MBB SERIES BORING BARS

Select the **ORDER CODE** in the table below that represents your selection of tool specifications.

### EXAMPLE:

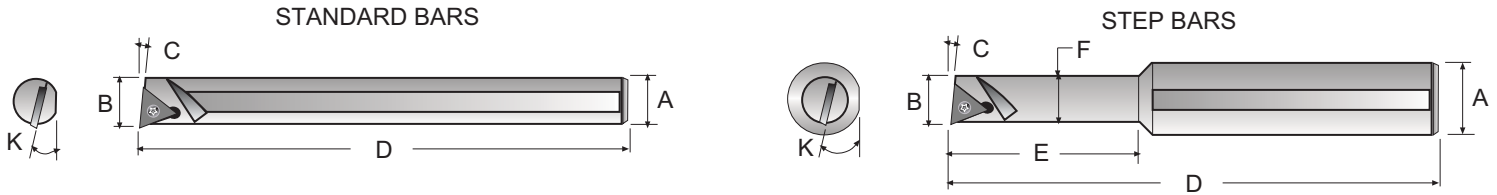
The **ORDER CODE** for a .300" minimum bore, right hand, heavy metal, .500" shank step bar is:  
**MBBH355030R150**



	TOOL SPECIFICATIONS								ORDER CODE					
	Minimum Bore	Material	Bar Diameter		Length		Lead Angle	'K' Angle	Boring Bar	Replacement Parts				
	'B'		'F'	'A'	'E'	'D'	'C'	'K'		Screw	Wrench			
.160" I.C.	With .007" radius insert	Extension Ratios: Steel: 4 x ø Heavy Metal: 6 x ø Carbide: 8 x ø	Neck	Shank	Neck	Overall		See Page 3-2	Includes Screw and Wrench					
Right Hand Bars  Use inserts beginning with 'MBBIW', 'MBBIZ', left hand 'MBBIG' inserts and most ANSI 'TD' standard inserts	.270"	Steel	.187"		---	3.500"	0°	17°	MBBS101827R	F22	W11			
			.187"		---	3.500"	5°	17°	MBBS151827R					
			.187"	.500"	1.000"	3.000"	5°	17°	MBBS355027R100					
		Heavy Metal	.187"		---	3.976"	0°	17°	MBBH101827R					
			.187"		---	3.976"	5°	17°	MBBH151827R					
			.187"	.500"	1.125"	3.965"	5°	17°	MBBH355027R112					
	Carbide	.187"		---	4.487"	5°	17°	MBBC151827R						
	.300"	Steel	.250"		---	4.000"	0°	12°	MBBS102530R	F22	W11			
			.250"		---	4.000"	5°	12°	MBBS152530R					
			.250"	.500"	1.250"	3.000"	5°	12°	MBBS355030R125					
			.250"	.625"	1.250"	4.000"	5°	12°	MBBS356230R125					
			Heavy Metal	.250"		---	3.976"	0°	12°			MBBH102530R		
				.250"		---	3.976"	5°	12°			MBBH152530R		
		.250"		.500"	1.500"	3.981"	5°	12°	MBBH355030R150					
		Carbide	.250"		---	6.488"	5°	12°	MBBC152530R					
		.350"	Steel	.313"		---	4.000"	0°	8°			MBBS103135R	F22	W11
				.313"		---	4.000"	5°	8°			MBBS153135R		
				.313"	.500"	1.000"	3.000"	5°	8°			MBBS355035R100		
				.313"	---	5.500"	0°	8°	MBBH103135R					
	Heavy Metal		.313"		---	5.500"	5°	8°	MBBH153135R					
			.313"	.500"	1.500"	3.981"	5°	8°	MBBH355035R150					
			.313"		---	6.483"	5°	8°	MBBC153135R					
			.313"		---	6.483"	5°	8°	MBBC153135R					
	Left Hand Bars  Use inserts beginning with 'MBBIW', 'MBBIZ', right hand 'MBBIG' inserts and most ANSI 'TD' standard inserts	.270"	Steel	.187"		---	3.500"	5°	17°	MBBS151827L	F22	W11		
.300"		Steel	.250"		---	4.000"	5°	12°	MBBS152530L					
.350"		Steel	.313"		---	4.000"	5°	8°	MBBS153135L					
		Heavy Metal	.313"		---	5.500"	5°	8°	MBBH153135L					

## KAISER TOOL COMPANY, INC.





Phone: 888-THINBIT (888-844-6248) or (260) 484-3620 • Fax: 888-THINFAX (888-844-6329) or (260) 482-1881  
www.thinbit.com • General E-mail: thinbit@kaisertool.com • Orders: orders@thinbit.com • Quotes: quotes@thinbit.com

# TO ORDER TD STYLE - MBB SERIES INSERTS

Select the **ORDER CODE** in the table below that represents your selection of insert specifications.

**EXAMPLE:**

The **ORDER CODE** for a molded chipbreaker, **DURA-MAX® 4000** insert with .007" radius and TiN coating is:  
**MBBIW07D4C**

TD Style MBB Series Use toolholders beginning with 'MBB'	SPECIFICATIONS		ORDER CODE					
	Insert Material	Corner Radius	Coating <small>See Page 9-5 for expanded material descriptions and Page 9-15 for Speeds and Feeds</small>					
			Uncoated	TiN	TiCN Non-stock	TiAlN Non-stock	Diamond Non-stock	
Flat top    TDAB Style	<b>DURA-MAX® 3000/4000</b> Carbide* For Steel & Interrupted Cutting	.002"	MBBI Z02D3U	MBBI Z02D3C	MBBI Z02D3D	MBBI Z02D3E	MBBI Z02D3F	
		.007"	MBBI Z07D3U	MBBI Z07D3C	MBBI Z07D3D	MBBI Z07D3E	MBBI Z07D3F	
		.015"	MBBI Z15D3U	MBBI Z15D3C	MBBI Z15D3D	MBBI Z15D3E	MBBI Z15D3F	
		.031"	MBBI Z31D3U	MBBI Z31D3C	MBBI Z31D3D	MBBI Z31D3E	MBBI Z31D3F	
	<b>DURA-MAX® 5000</b> Carbide For Aluminum & Nonferrous	.002"	MBBI Z02D5U	MBBI Z02D5C	MBBI Z02D5D	MBBI Z02D5E	MBBI Z02D5F	
		.007"	MBBI Z07D5U	MBBI Z07D5C	MBBI Z07D5D	MBBI Z07D5E	MBBI Z07D5F	
		.015"	MBBI Z15D5U	MBBI Z15D5C	MBBI Z15D5D	MBBI Z15D5E	MBBI Z15D5F	
		.031"	MBBI Z31D5U	MBBI Z31D5C	MBBI Z31D5D	MBBI Z31D5E	MBBI Z31D5F	
	<b>DURA-MAX® 8000</b> CBN For Hardened Materials	.002"	MBBI Z02D8					
		.007"	MBBI Z07D8					
		.015"	MBBI Z15D8					
		.031"	MBBI Z31D8					
	<b>DURA-MAX® 9000</b> PCD For Abrasive Nonferrous	.002"	MBBI Z02D9					
		.007"	MBBI Z07D9					
		.015"	MBBI Z15D9					
		.031"	MBBI Z31D9					
Molded Chipbreaker    TDCH Style	<b>DURA-MAX® 4000</b> Carbide For Steel & Interrupted Cutting	.007"	MBBIW07D4U	MBBIW07D4C	MBBIW07D4D	MBBIW07D4E	MBBIW07D4F	
		.015"	MBBIW15D4U	MBBIW15D4C	MBBIW15D4D	MBBIW15D4E	MBBIW15D4F	
	<b>DURA-MAX® 5000</b> Carbide For Aluminum & Nonferrous	.007"	MBBIW07D5U	MBBIW07D5C	MBBIW07D5D	MBBIW07D5E	MBBIW07D5F	
		.015"	MBBIW15D5U	MBBIW15D5C	MBBIW15D5D	MBBIW15D5E	MBBIW15D5F	
Ground Chipbreaker Right Hand for Left Hand Bars    TDCG Style	<b>DURA-MAX® 3000</b> Carbide For Steel & Interrupted Cutting	.002"	MBBIG02D3UR	MBBIG02D3CR	MBBIG02D3DR	MBBIG02D3ER	MBBIG02D3FR	
		.007"	MBBIG07D3UR	MBBIG07D3CR	MBBIG07D3DR	MBBIG07D3ER	MBBIG07D3FR	
		.015"	MBBIG15D3UR	MBBIG15D3CR	MBBIG15D3DR	MBBIG15D3ER	MBBIG15D3FR	
		.031"	MBBIG31D3UR	MBBIG31D3CR	MBBIG31D3DR	MBBIG31D3ER	MBBIG31D3FR	
	<b>DURA-MAX® 5000</b> Carbide For Aluminum & Nonferrous	.002"	MBBIG02D5UR	MBBIG02D5CR	MBBIG02D5DR	MBBIG02D5ER	MBBIG02D5FR	
		.007"	MBBIG07D5UR	MBBIG07D5CR	MBBIG07D5DR	MBBIG07D5ER	MBBIG07D5FR	
		.015"	MBBIG15D5UR	MBBIG15D5CR	MBBIG15D5DR	MBBIG15D5ER	MBBIG15D5FR	
		.031"	MBBIG31D5UR	MBBIG31D5CR	MBBIG31D5DR	MBBIG31D5ER	MBBIG31D5FR	
	Ground Chipbreaker Left Hand for Right Hand Bars    TDCG Style	<b>DURA-MAX® 3000</b> Carbide For Steel & Interrupted Cutting	.002"	MBBIG02D3UL	MBBIG02D3CL	MBBIG02D3DL	MBBIG02D3EL	MBBIG02D3FL
			.007"	MBBIG07D3UL	MBBIG07D3CL	MBBIG07D3DL	MBBIG07D3EL	MBBIG07D3FL
			.015"	MBBIG15D3UL	MBBIG15D3CL	MBBIG15D3DL	MBBIG15D3EL	MBBIG15D3FL
			.031"	MBBIG31D3UL	MBBIG31D3CL	MBBIG31D3DL	MBBIG31D3EL	MBBIG31D3FL
<b>DURA-MAX® 5000</b> Carbide For Aluminum & Nonferrous		.002"	MBBIG02D5UL	MBBIG02D5CL	MBBIG02D5DL	MBBIG02D5EL	MBBIG02D5FL	
		.007"	MBBIG07D5UL	MBBIG07D5CL	MBBIG07D5DL	MBBIG07D5EL	MBBIG07D5FL	
		.015"	MBBIG15D5UL	MBBIG15D5CL	MBBIG15D5DL	MBBIG15D5EL	MBBIG15D5FL	
		.031"	MBBIG31D5UL	MBBIG31D5CL	MBBIG31D5DL	MBBIG31D5EL	MBBIG31D5FL	

**MBB BARS & INSERTS BORING**

\* For some details, **DURA-MAX® 4000** may be substituted.

## KAISER TOOL COMPANY, INC.

Phone: 888-THINBIT (888-844-6248) or (260) 484-3620 • Fax: 888-THINFAX (888-844-6329) or (260) 482-1881  
www.thinbit.com • General E-mail: thinbit@kaisertool.com • Orders: orders@thinbit.com • Quotes: quotes@thinbit.com

# TO ORDER TP STYLE - MBC SERIES BORING BARS

Select the **ORDER CODE** in the table below that represents your selection of tool specifications.

**EXAMPLE:**

The **ORDER CODE** for a .430" minimum bore, right hand, steel, .375" shank is:  
**MBCS153743R**

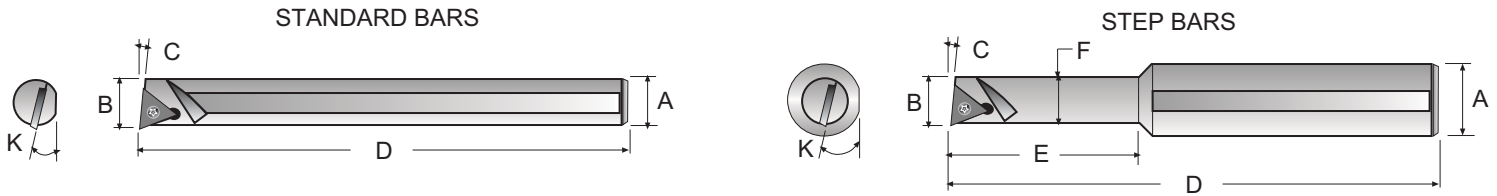

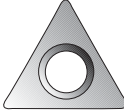
 .250" I.C.	TOOL SPECIFICATIONS							ORDER CODE				
	Minimum Bore	Material	Bar Diameter		Length		Lead Angle	'K' Angle	Boring Bar		Replacement Parts	
	'B'		'F'	'A'	'E'	'D'	'C'	'K'	Includes Screw and Wrench		Screw	Wrench
Use inserts beginning with 'MBCIW', 'MBCIZ', left hand 'MBCIG' inserts and most ANSI 'TP' standard inserts	.430"	Steel	.375"		---	5.500"	0°	8°	MBCS103743R		F31	W31
			.375"		---	5.500"	5°	8°	MBCS153743R			
			.375"	.750"	1.125"	4.000"	5°	8°	MBCS357543R112			
		Heavy Metal	.375"		---	5.500"	5°	8°	MBCH153743R			
			.375"	.500"	2.250"	3.988"	5°	8°	MBCH355043R225			
	Carbide	.375"		---	6.783"	5°	8°	MBCC153743R				
	.560"	Steel	.500"		---	5.500"	5°	2°	MBCS155056R		F31	W31
			.500"	.625"	1.500"	4.000"	5°	2°	MBCS356256R150			
		Heavy Metal	.500"		---	5.500"	5°	2°	MBCH155056R			
		Carbide	.500"		---	6.769"	5°	2°	MBCC155056R			
.680"	Steel	.625"		---	5.500"	5°	2°	MBCS156268R		F31	W31	
Left Hand Bars Use inserts beginning with 'MBCIW', 'MBCIZ', right hand 'MBCIG' inserts and most ANSI 'TP' standard inserts	.430"	Steel	.375"		---	5.500"	5°	8°	MBCS153743L		F31	W31

## KAISER TOOL COMPANY, INC.

Phone: 888-THINBIT (888-844-6248) or (260) 484-3620 • Fax: 888-THINFAX (888-844-6329) or (260) 482-1881  
www.thinbit.com • General E-mail: thinbit@kaisertool.com • Orders: orders@thinbit.com • Quotes: quotes@thinbit.com





# TO ORDER TP STYLE - MBC SERIES INSERTS

Select the **ORDER CODE** in the table below that represents your selection of insert specifications.

**EXAMPLE:**

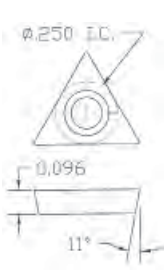
The **ORDER CODE** for a molded chipbreaker, **DURA-MAX® 5000** insert with .015" radius and TiN coating is:  
**MBCIW15D5C**

**MBC BARS  
& INSERTS  
BORING**







TP Style MBC Series Use toolholders beginning with 'MBC'	SPECIFICATIONS		ORDER CODE					
	Insert Material	Corner Radius	Coating <small>See Page 9-5 for expanded material descriptions and Page 9-15 for Speeds and Feeds</small>					
			Uncoated	TiN	TiCN Non-stock	TiAlN Non-stock	Diamond Non-stock	
Flat top    TPCB Style	<b>DURA-MAX® 3000/4000</b> Carbide* For Steel & Interrupted Cutting	.002"	MBCIZ02D3U	MBCIZ02D3C	MBCIZ02D3D	MBCIZ02D3E	MBCIZ02D3F	
		.007"	MBCIZ07D3U	MBCIZ07D3C	MBCIZ07D3D	MBCIZ07D3E	MBCIZ07D3F	
		.015"	MBCIZ15D4U	MBCIZ15D4C	MBCIZ15D4D	MBCIZ15D4E	MBCIZ15D4F	
		.031"	MBCIZ31D3U	MBCIZ31D3C	MBCIZ31D3D	MBCIZ31D3E	MBCIZ31D3F	
	<b>DURA-MAX® 5000</b> Carbide For Aluminum & Nonferrous	.002"	MBCIZ02D5U	MBCIZ02D5C	MBCIZ02D5D	MBCIZ02D5E	MBCIZ02D5F	
		.007"	MBCIZ07D5U	MBCIZ07D5C	MBCIZ07D5D	MBCIZ07D5E	MBCIZ07D5F	
		.015"	MBCIZ15D5U	MBCIZ15D5C	MBCIZ15D5D	MBCIZ15D5E	MBCIZ15D5F	
	<b>DURA-MAX® 8000</b> CBN For Hardened Materials	.002"	MBCIZ02D8					
		.007"	MBCIZ07D8					
		.015"	MBCIZ15D8					
		.031"	MBCIZ31D8					
	<b>DURA-MAX® 9000</b> PCD For Abrasive Nonferrous	.002"	MBCIZ02D9					
		.007"	MBCIZ07D9					
		.015"	MBCIZ15D9					
		.031"	MBCIZ31D9					
	Molded Chipbreaker    TPCH Style	<b>DURA-MAX® 3000</b> Carbide* For Steel & Interrupted Cutting	.015"	MBCIW15D3U	MBCIW15D3C	MBCIW15D3D	MBCIW15D3E	MBCIW15D3F
.031"			MBCIW31D3U	MBCIW31D3C	MBCIW31D3D	MBCIW31D3E	MBCIW31D3F	
<b>DURA-MAX® 5000</b> Carbide For Aluminum & Nonferrous		.015"	MBCIW15D5U	MBCIW15D5C	MBCIW15D5D	MBCIW15D5E	MBCIW15D5F	
		.031"	MBCIW31D5U	MBCIW31D5C	MBCIW31D5D	MBCIW31D5E	MBCIW31D5F	
Ground Chipbreaker Right Hand for Left Hand Bars    TPCG Style	<b>DURA-MAX® 3000/4000</b> Carbide* For Steel & Interrupted Cutting	.002"	MBCIG02D3UR	MBCIG02D3CR	MBCIG02D3DR	MBCIG02D3ER	MBCIG02D3FR	
		.007"	MBCIG07D3UR	MBCIG07D3CR	MBCIG07D3DR	MBCIG07D3ER	MBCIG07D3FR	
		.015"	MBCIG15D4UR	MBCIG15D4CR	MBCIG15D4DR	MBCIG15D4ER	MBCIG15D4FR	
		.031"	MBCIG31D3UR	MBCIG31D3CR	MBCIG31D3DR	MBCIG31D3ER	MBCIG31D3FR	
	<b>DURA-MAX® 5000</b> Carbide For Aluminum & Nonferrous	.002"	MBCIG02D5UR	MBCIG02D5CR	MBCIG02D5DR	MBCIG02D5ER	MBCIG02D5FR	
		.007"	MBCIG07D5UR	MBCIG07D5CR	MBCIG07D5DR	MBCIG07D5ER	MBCIG07D5FR	
		.015"	MBCIG15D5UR	MBCIG15D5CR	MBCIG15D5DR	MBCIG15D5ER	MBCIG15D5FR	
		.031"	MBCIG31D5UR	MBCIG31D5CR	MBCIG31D5DR	MBCIG31D5ER	MBCIG31D5FR	
Ground Chipbreaker Left Hand for Right Hand Bars    TPCG Style	<b>DURA-MAX® 3000/4000</b> Carbide* For Steel & Interrupted Cutting	.002"	MBCIG02D3UL	MBCIG02D3CL	MBCIG02D3DL	MBCIG02D3EL	MBCIG02D3FL	
		.007"	MBCIG07D3UL	MBCIG07D3CL	MBCIG07D3DL	MBCIG07D3EL	MBCIG07D3FL	
		.015"	MBCIG15D4UL	MBCIG15D4CL	MBCIG15D4DL	MBCIG15D4EL	MBCIG15D4FL	
		.031"	MBCIG31D3UL	MBCIG31D3CL	MBCIG31D3DL	MBCIG31D3EL	MBCIG31D3FL	
	<b>DURA-MAX® 5000</b> Carbide For Aluminum & Nonferrous	.002"	MBCIG02D5UL	MBCIG02D5CL	MBCIG02D5DL	MBCIG02D5EL	MBCIG02D5FL	
		.007"	MBCIG07D5UL	MBCIG07D5CL	MBCIG07D5DL	MBCIG07D5EL	MBCIG07D5FL	
		.015"	MBCIG15D5UL	MBCIG15D5CL	MBCIG15D5DL	MBCIG15D5EL	MBCIG15D5FL	
		.031"	MBCIG31D5UL	MBCIG31D5CL	MBCIG31D5DL	MBCIG31D5EL	MBCIG31D5FL	

\* For some details, **DURA-MAX® 4000** may be substituted.

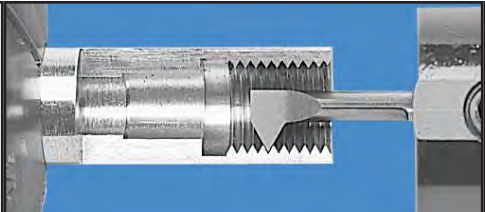
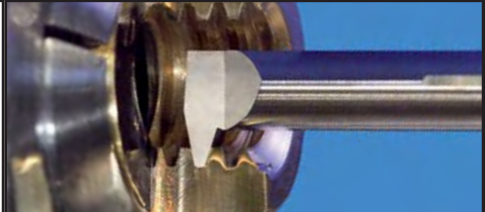
## KAISER TOOL COMPANY, INC.

Phone: 888-THINBIT (888-844-6248) or (260) 484-3620 • Fax: 888-THINFAX (888-844-6329) or (260) 482-1881  
www.thinbit.com • General E-mail: thinbit@kaisertool.com • Orders: orders@thinbit.com • Quotes: quotes@thinbit.com

## PRODUCT SELECTION GUIDE - THREADING & CHAMFERING

<p>PAGE 4-3</p>		<ul style="list-style-type: none"> <li>• 60° Profile for internal diameters of .077" and larger</li> <li>• 4 Threads per inch and greater</li> <li>• Solid carbide shanks in 1/8", 3/16", 1/4", 5/16", 3/8" and 1/2" diameter</li> </ul>
<p>PAGE 4-5</p>		<ul style="list-style-type: none"> <li>• ACME profile</li> <li>• For internal diameters of .187" and larger</li> <li>• 6 Threads per inch and greater</li> </ul>
<p>PAGE 4-7</p>		<ul style="list-style-type: none"> <li>• 60° Profile for internal diameters of .325" and larger</li> <li>• 9 Threads per inch and greater</li> </ul>
<p>PAGE 4-9</p>		<ul style="list-style-type: none"> <li>• 60° Profile for external and internal threading</li> <li>• For internal diameters of 1.250" and larger</li> <li>• 8 Threads per inch and greater</li> <li>• Carbide and High Speed Steel</li> </ul>
<p>PAGE 4-11</p>		<ul style="list-style-type: none"> <li>• ACME Profile for external and internal threading</li> <li>• For internal diameters of 1.250" and larger</li> <li>• 4 Threads per inch and greater</li> <li>• Carbide and High Speed Steel</li> </ul>
<p>PAGE 4-13</p>		<ul style="list-style-type: none"> <li>• Chamfering inserts for external and internal use</li> <li>• For internal diameters of 1.250" and larger</li> <li>• Carbide and High Speed Steel</li> </ul>
<p>PAGE 1-13</p>		<ul style="list-style-type: none"> <li>• 3mm Threading &amp; Chamfering style inserts (Pg. 6-2)</li> <li>• Can thread over a .500" long shoulder</li> <li>• Can back thread along a shoulder</li> </ul>



www.thinbit.com/qr4-1  
Scan this code  
for additional  
information

# THINBIT®

OVER 100,000 TOOLS IN STOCK FOR  
GROOVING • THREADING • PARTING • BORING  
TURNING • FACE GROOVING

**KAISER TOOL COMPANY, INC.**

Phone: 888-THINBIT (888-844-6248) or (260) 484-3620 • Fax: 888-THINFAX (888-844-6329) or (260) 482-1881  
www.thinbit.com • General E-mail: thinbit@kaisertool.com • Orders: orders@thinbit.com • Quotes: quotes@thinbit.com



# TOOLING ORIENTATION GUIDE - THREADING & CHAMFERING

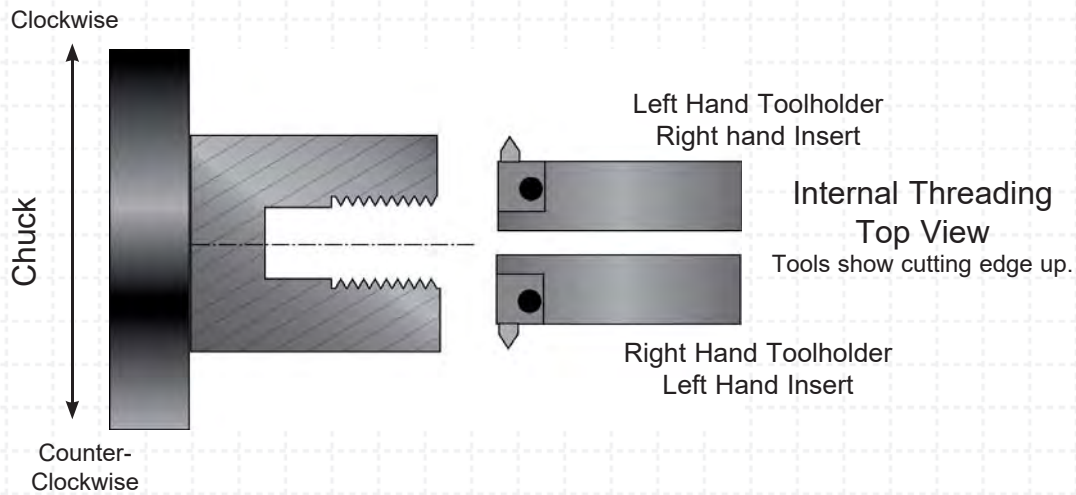
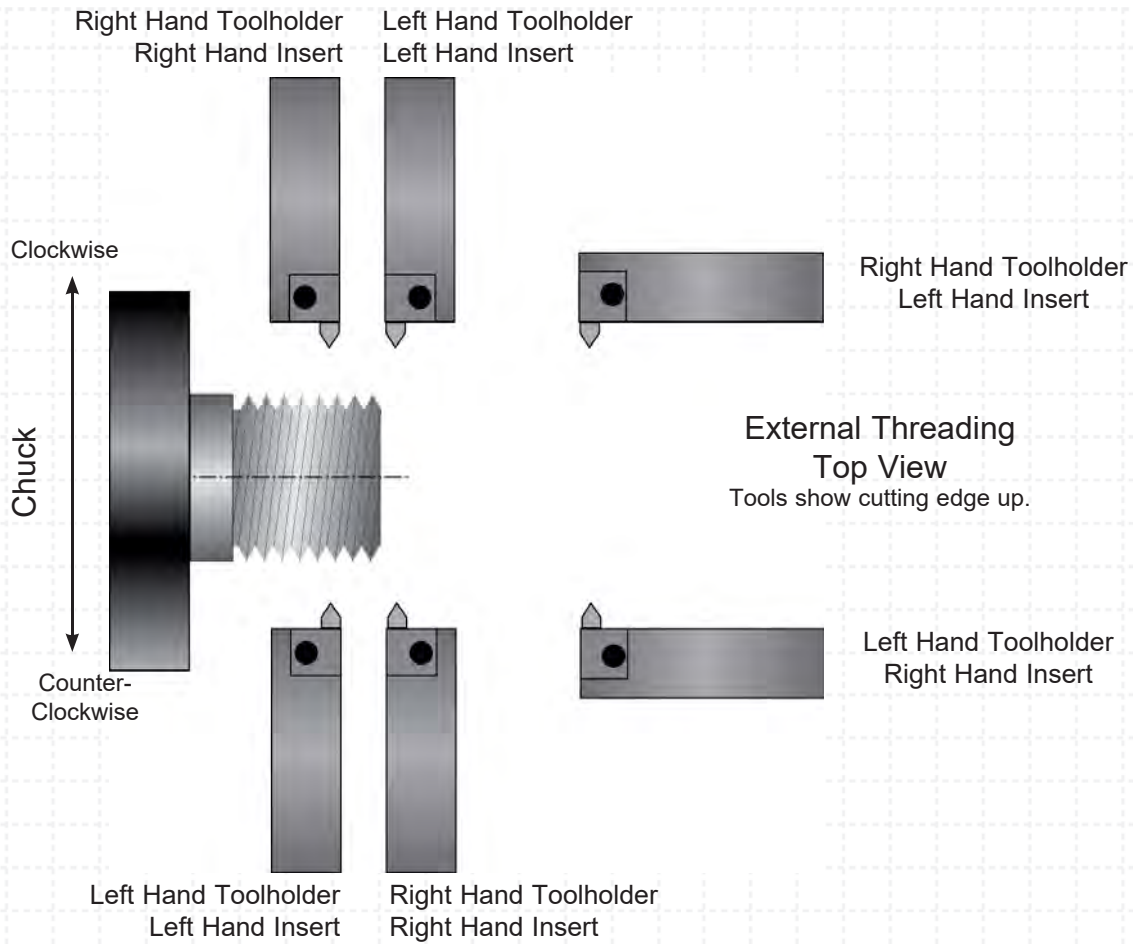

# THREADING

## KAISER TOOL COMPANY, INC.

## PRODUCT INFORMATION

- Internal threading for diameters .077" and larger.
- 4 threads per inch and greater.
- 1/8", 3/16", 1/4", 5/16", 3/8" and 1/2" shank.
- Short neck lengths for greater rigidity; long neck lengths for greater reach.
- Elliptically ground necks for greater strength; round necks to fit into small diameters.
- Sub-micron grain **DURA-MAX® 2000** Carbide.
- Tools can be coated with TiN, TiAlN, TiCN and Diamond coating.

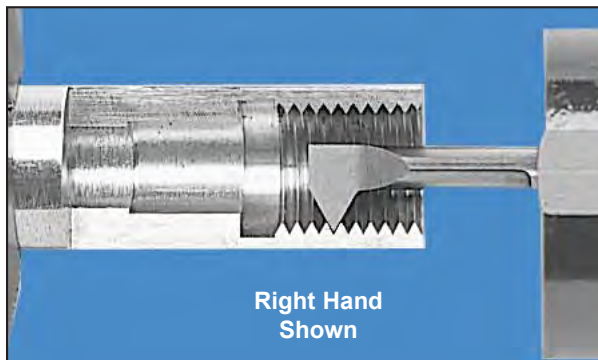

## MODIFICATIONS

SEE PAGE 8-3 FOR ADDITIONAL INFORMATION

### INCLUDED ANGLE (TOP VIEW)



### CUSTOM THREADS (TOP VIEW)



### CUSTOM BLANK (TOP VIEW)

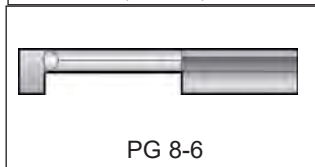

## ADAPTER STYLES

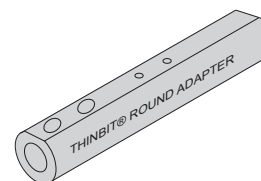

PG 7-2

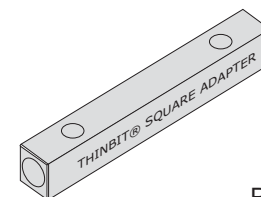

PG 7-2

## TOOLHOLDER SELECTIONS

## TECHNICAL SECTIONS

### PRODUCT DEMONSTRATION



[www.thinbit.com/qr4-3](http://www.thinbit.com/qr4-3)

### SPEEDS AND FEEDS

PG 9-18

### APPLICATION REFERENCE

PG 9-4

### TROUBLESHOOTING

PG 9-7

## Right Hand Illustrated

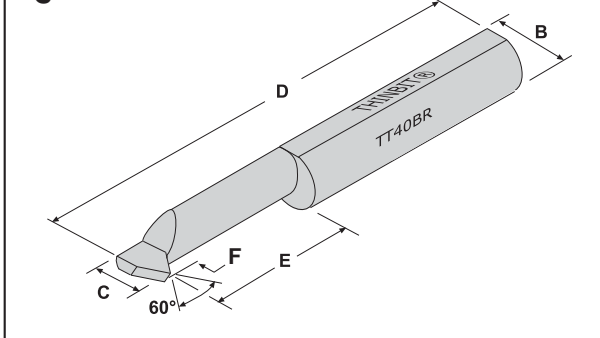

FRONT RAKE: Primary 21°

RADIUS: .002" or .000"

TOP RAKE: 0°

**NOTE:** Tool designed for feeding into bore only. Right hand tools should be used for right hand internal threads. Left hand tools should be used for left hand internal threads.

Select the **ORDER CODE** in the table on the next page that represents your selection of tool dimensions.

### EXAMPLE:

The **ORDER CODE** for a .250" minimum bore, right hand tool for 5 to 56 T.P.I. and .620" tool reach is: **TT40BR**

## KAISER TOOL COMPANY, INC.

Phone: 888-THINBIT (888-844-6248) or (260) 484-3620 • Fax: 888-THINFAX (888-844-6329) or (260) 482-1881  
[www.thinbit.com](http://www.thinbit.com) • General E-mail: [thinbit@kaisertool.com](mailto:thinbit@kaisertool.com) • Orders: [orders@thinbit.com](mailto:orders@thinbit.com) • Quotes: [quotes@thinbit.com](mailto:quotes@thinbit.com)

# I.D. THREADING TOOLS

SPECIFICATIONS			ORDER CODE						INFORMATION			
Minimum Bore  'C'	Threads per Inch	Tool Reach  'E'	DURA-MAX® 2000 Carbide <small>See Page 9-18 for Speeds and Feeds information</small>		Coatings <small>See Page 9-6 for Expanded Coating Descriptions</small>				Overall Length  'D'	Projection  'F'	Shank Diameter  'B'	Toolholder Page 7-2  Use Toolholders Beginning With
			Minimum	Right Hand	Left Hand	TiN	TiCN	TiAlN				
.077" Round Neck	40 to 56	.291"	TT20AR	TT20AL	add 'C'	add 'D'	add 'E'	add 'F'	1.397"	.014"	1/8"	'AD'
		.416"	TT21AR	TT21AL								
	Over 56	.291"	TT20AR1	TT20AL1								
		.416"	TT21AR1	TT21AL1								
.125"	11 to 56	.312"	TT20BR	TT20BL	add 'C'	add 'D'	add 'E'	add 'F'	1.439"	.050"	1/8"	'AD'
		.437"	TT21BR	TT21BL								
	Over 56	.312"	TT20BR1	TT20BL1								
		.437"	TT21BR1	TT21BL1								
	27 to 56	.294"	TT20CR	TT20CL					1.404"	.020"		
		.419"	TT21CR	TT21CL								
	Over 56	.294"	TT20CR1	TT20CL1								
		.419"	TT21CR1	TT21CL1								
.187"	7 to 56	.454"	TT30BR	TT30BL	add 'C'	add 'D'	add 'E'	add 'F'	1.974"	.080"	3/16"	'AD'
		.704"	TT31BR	TT31BL								
	Over 56	.454"	TT30BR1	TT30BL1								
		.704"	TT31BR1	TT31BL1								
	16 to 56	.428"	TT30CR	TT30CL					1.922"	.035"		
		.678"	TT31CR	TT31CL								
	Over 56	.428"	TT30CR1	TT30CL1								
		.678"	TT31CR1	TT31CL1								
.250"	5 to 56	.596"	TT40BR	TT40BL	add 'C'	add 'D'	add 'E'	add 'F'	2.508"	.110"	1/4"	'AD'
		.846"	TT41BR	TT41BL								
	Over 56	.596"	TT40BR1	TT40BL1								
		.846"	TT41BR1	TT41BL1								
	11 to 56	.562"	TT40CR	TT40CL					2.439"	.050"		
		.812"	TT41CR	TT41CL								
	Over 56	.562"	TT40CR1	TT40CL1								
		.812"	TT41CR1	TT41CL1								
.313"	4 to 56	.739"	TT50BR	TT50BL	add 'C'	add 'D'	add 'E'	add 'F'	2.513"	.140"	5/16"	'AD'
		1.114"	TT51BR	TT51BL								
	Over 56	.739"	TT50BR1	TT50BL1								
		1.114"	TT51BR1	TT51BL1								
	9 to 56	.694"	TT50CR	TT50CL					2.424"	.063"		
		1.069"	TT51CR	TT51CL								
	Over 56	.694"	TT50CR1	TT50CL1								
		1.069"	TT51CR1	TT51CL1								
.375"	5 to 56	.846"	TT60CR	TT60CL	add 'C'	add 'D'	add 'E'	add 'F'	2.948"	.110"	3/8"	'AD'
		1.346"	TT61CR	TT61CL								
	Over 56	.846"	TT60CR1	TT60CL1								
		1.346"	TT61CR1	TT61CL1								
.500"	4 to 56	1.119"	TT80CR	TT80CL	add 'C'	add 'D'	add 'E'	add 'F'	3.434"	.150"	1/2"	'AD'
		1.869"	TT81CR	TT81CL								
	Over 56	1.119"	TT80CR1	TT80CL1								
		1.869"	TT81CR1	TT81CL1								

I.D. TOOLS  
THREADING

## PRODUCT INFORMATION

- Internal ACME threading for diameters .187" and larger.
- 6 threads per inch and greater.
- 3/16", 1/4", 5/16" and 3/8".
- Short neck lengths for greater rigidity; long neck lengths for greater reach.
- Elliptically ground necks for greater strength; round necks to fit into small diameters.
- Sub-micron grain **DURA-MAX® 2000** Carbide.
- Tools can be coated with TiN, TiAlN, TiCN and Diamond coating.

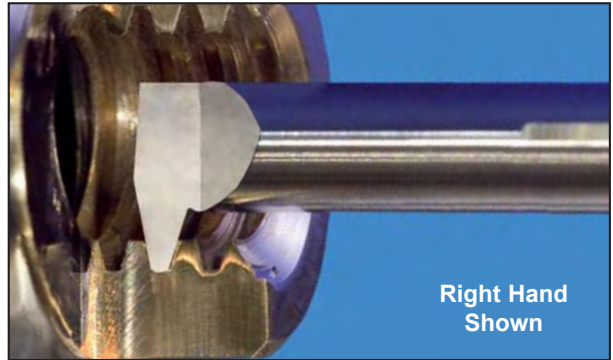

Right Hand Shown

## MODIFICATIONS

SEE PAGE  
8-3  
FOR ADDITIONAL  
INFORMATION

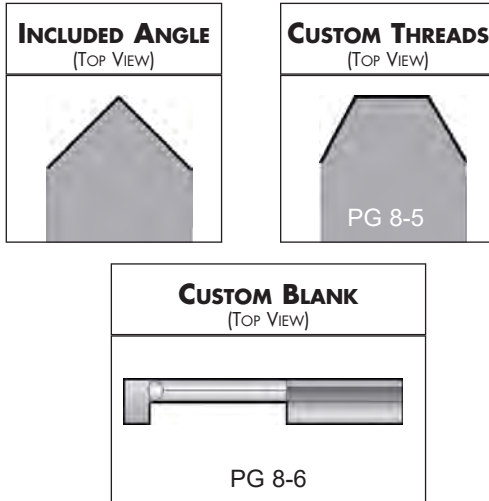

## TOOLHOLDER SELECTIONS

### ADAPTER STYLES

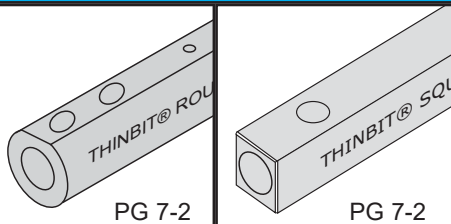

## TECHNICAL SECTIONS

### PRODUCT DEMONSTRATION



[www.thinbit.com/gr4-5](http://www.thinbit.com/gr4-5)

### SPEEDS AND FEEDS

PG 9-18

### APPLICATION REFERENCE

PG 9-4

### TROUBLESHOOTING

PG 9-7

## KAISER TOOL COMPANY, INC.

Phone: 888-THINBIT (888-844-6248) or (260) 484-3620 • Fax: 888-THINFAX (888-844-6329) or (260) 482-1881  
www.thinbit.com • General E-mail: [thinbit@kaisertool.com](mailto:thinbit@kaisertool.com) • Orders: [orders@thinbit.com](mailto:orders@thinbit.com) • Quotes: [quotes@thinbit.com](mailto:quotes@thinbit.com)

## I.D. ACME THREADING TOOLS

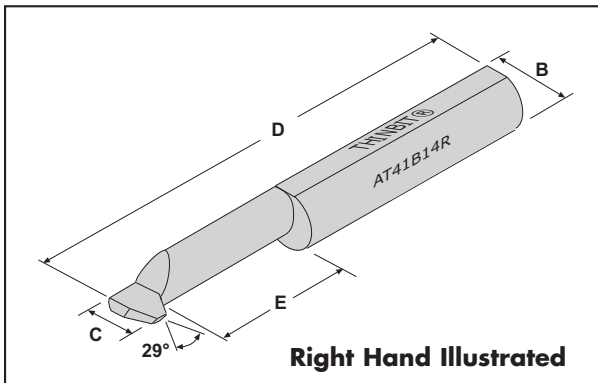

FRONT RAKE: Primary 21°

TOP RAKE: 0°

NOTE: Tool designed for feeding into bore only. Right hand tools should be used for right hand internal threads. Left hand tools should be used for left hand internal threads.

- 29° ACME threading inserts for internal and external applications.
- ACME threading tools can be used to cut other thread profiles by over cutting.
- Single lead

## ORDERING INSTRUCTIONS

Select the **ORDER CODE** in the table below that represents your selection of tool dimensions.

**EXAMPLE:**

The **ORDER CODE** for a .250" minimum bore, right hand tool for 14 or fewer T.P.I. and .750" tool reach is:

**AT41B14R**

I.D. ACME THREADING

SPECIFICATIONS				ORDER CODE					INFORMATION			
Minimum Bore 'C'	Threads per Inch	Flat at Tip	Tool Reach 'E' Minimum	DURA-MAX® 2000 Carbide See Page 9-18 for Speeds and Feeds information		Coatings See Page 9-6 for Expanded Coating Descriptions Use Uncoated Part Number and Add Coating Code				Overall Length 'D'	Shank Diameter 'B'	Toolholder Page 7-2  Use Toolholders Beginning With
				Right Hand	Left Hand	TiN	TiCN	TiAlN	Diamond			
.187"	16	.021"	.625"	AT31B16R	AT31B16L					1.902"	3/16"	'AD'
.250"	14	.024"	.750"	AT41B14R	AT41B14L					2.413"	1/4"	
.313"	12	.028"	1.000"	AT51B12R	AT51B12L	add 'C'	add 'D'	add 'E'	add 'F'	2.388"	5/16"	
.375"	10	.032"	1.250"	AT61C10R	AT61C10L					2.893"	3/8"	
.375"	6	.057"	1.250"	AT61C06R	AT61C06L					2.863"	3/8"	

## KAISER TOOL COMPANY, INC.



**PRODUCT INFORMATION**

- Internal threading for diameters .325" and larger.
- 9 threads per inch and greater.
- Sub-micron grain **DURA-MAX**<sup>®</sup> **2000** and **5000** Carbides.
- Inserts available coated with TiN, TiAlN, TiCN and Diamond coating.



Right Hand Toolholder with Left Hand Insert Shown

**MODIFICATIONS**

SEE PAGE 8-3 FOR ADDITIONAL INFORMATION

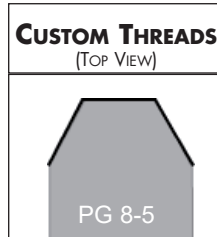
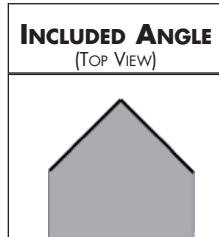

**TOOLHOLDER SELECTION**

**ROUND STYLES**

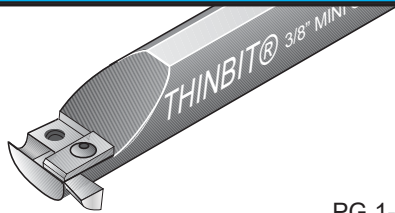

PG 1-6

**TECHNICAL SECTIONS**

	PRODUCT DEMONSTRATION	SPEEDS AND FEEDS	APPLICATION REFERENCE	TROUBLESHOOTING
	 <a href="http://www.thinbit.com/qr4-7">www.thinbit.com/qr4-7</a>	PG 9-18	PG 9-4	PG 9-7

**KAISER TOOL COMPANY, INC.**

# I.D. THREADING TOOLS

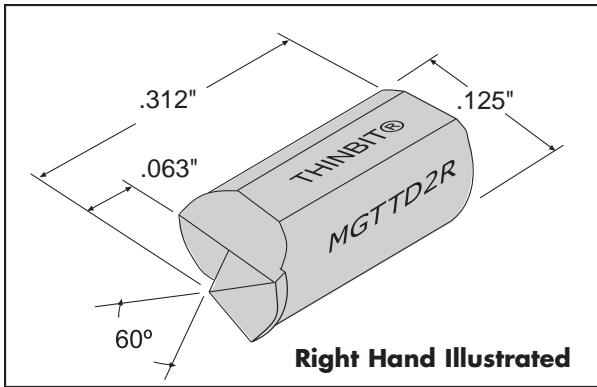

FRONT RAKE: 15°  
 RADIUS: .002" or .000"  
 TOP RAKE: 0°

## ORDERING INSTRUCTIONS

Select the **ORDER CODE** in the table below that represents your selection of insert specifications.

**EXAMPLE:**

The **ORDER CODE** for a right hand, 9 to 56 Threads Per Inch **DURA-MAX® 2000** Carbide insert with TiN coating is:  
**MGTTD2RC**

I.D. TOOLS  
THREADING

SPECIFICATIONS		ORDER CODE						INFO.
Insert Orientation	Threads per Inch	Insert Grades See Page 9-5 for Expanded Material Descriptions and Page 9-18 for Speeds and Feeds		Coatings See Page 9-6 for Expanded Coating Descriptions				Toolholder Page 1-6  Use Toolholders Beginning With
		DURA-MAX® 2000 Carbide For Steel & Interrupted Cutting	DURA-MAX® 5000 Carbide For Aluminum & Nonferrous	Use Uncoated Part Number and Add Coating Code				
				TiN	TiCN	TiAlN	Diamond	
Right Hand	9 to 56	MGTTD2R	MGTTD5R	add 'C'	add 'D'	add 'E'	add 'F'	'MGT'
	Greater than 56	MGTTD2R1	MGTTD5R1					Use left hand holder
Left Hand	9 to 56	MGTTD2L	MGTTD5L	add 'C'	add 'D'	add 'E'	add 'F'	'MGT'
	Greater than 56	MGTTD2L1	MGTTD5L1					Use right hand holder

## KAISER TOOL COMPANY, INC.

Phone: 888-THINBIT (888-844-6248) or (260) 484-3620 • Fax: 888-THINFAX (888-844-6329) or (260) 482-1881  
 www.thinbit.com • General E-mail: thinbit@kaisertool.com • Orders: orders@thinbit.com • Quotes: quotes@thinbit.com

## PRODUCT INFORMATION

- External threading within .065" of a shoulder.
- Internal threading with 1.250" minimum bore diameter.
- 8 threads per inch and greater.
- Sub-micron grain **DURA-MAX® 2000** and **5000** Carbides and High Speed Steel.
- Inserts can be coated with TiN, TiAlN, TiCN and Diamond coating.

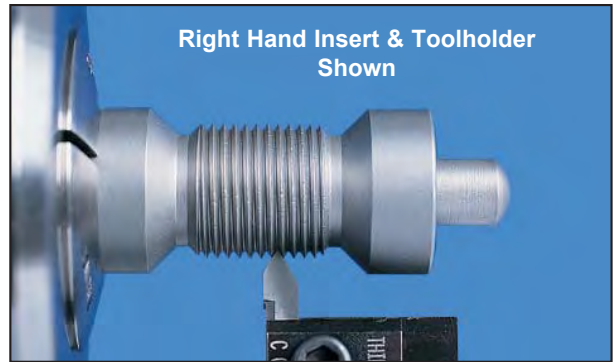

## MODIFICATIONS

SEE PAGE  
8-3  
FOR ADDITIONAL  
INFORMATION

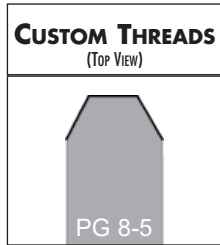
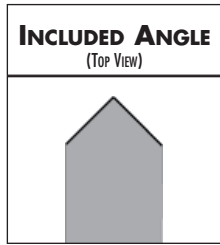

## TOOLHOLDER SELECTIONS

### CNC, SWISS, CONVENTIONAL STYLE

### ROUND STYLE

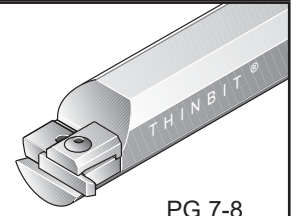
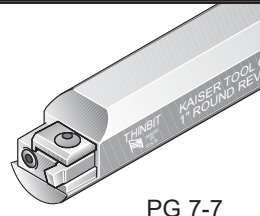
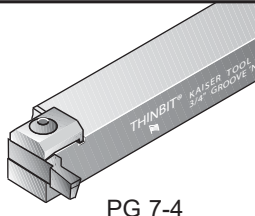
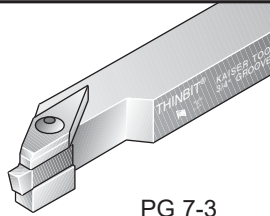

## TECHNICAL SECTIONS

### PRODUCT DEMONSTRATION



[www.thinbit.com/qr4-9](http://www.thinbit.com/qr4-9)

### SPEEDS AND FEEDS

PG 9-18

### APPLICATION REFERENCE

PGS 9-3 & 9-4

### TROUBLESHOOTING

PG 9-7

## KAISER TOOL COMPANY, INC.

# THREADING INSERTS

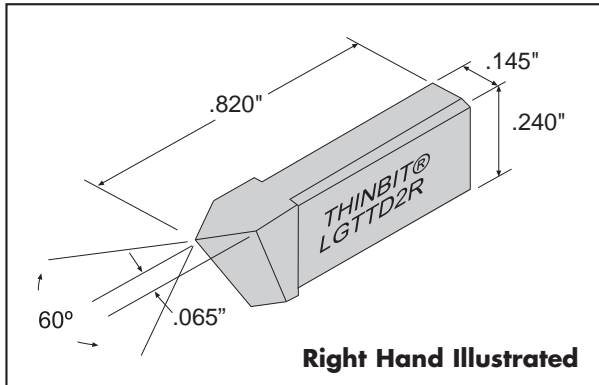

FRONT RAKE: 15°  
 RADIUS: .002" or .000"  
 TOP RAKE: 0°

Right Hand Illustrated

## ORDERING INSTRUCTIONS

Select the **ORDER CODE** in the table below that represents your selection of orientation and insert grade.

**EXAMPLE:**

The **ORDER CODE** for a right hand, 8 to 56 Threads Per Inch threading insert in **DURA-MAX® 2000** is:  
**LGTTD2R**

INSERTS  
THREADING

SPECIFICATIONS		ORDER CODE						INFO.	
Insert Orientation	Threads per Inch	Insert Grades See Page 9-5 for expanded material selections and Page 9-18 for Speeds and Feeds information			Coatings See Page 9-6 for Expanded Coating Descriptions				Toolholder Catalog Section 7  Use Toolholders Beginning With
		DURA-MAX® 2000 Carbide For Steel & Interrupted Cutting	DURA-MAX® 5000 Carbide For Aluminum & Nonferrous	High Speed Steel	Use Uncoated Part Number and Add Coating Code				
					TiN	TiCN	TiAlN	Diamond	
Right Hand For right hand external threads or left hand internal threads	8 to 56	LGTTD2R	LGTTD5R	LGTTHSR					'L' Use right hand straight holder or left hand 90° holder
	Greater than 56	LGTTD2R1	LGTTD5R1	LGTTHSR1	add 'C'	add 'D'	add 'E'	add 'F'	
Left Hand For left hand external threads or right hand internal threads	8 to 56	LGTTD2L	LGTTD5L	LGTTHSL					'L' Use left hand straight holder or right hand 90° holder
	Greater than 56	LGTTD2L1	LGTTD5L1	LGTTHSL1	add 'C'	add 'D'	add 'E'	add 'F'	

### KAISER TOOL COMPANY, INC.

## PRODUCT INFORMATION

- External threading within .070" of a shoulder.
- Internal ACME threading with 1.250" minimum bore diameter.
- 4 threads per inch and greater.
- Sub-micron grain **DURA-MAX® 2000** and **5000** Carbides and High Speed Steel.
- Inserts can be coated with TiN, TiAlN, TiCN and Diamond coating.

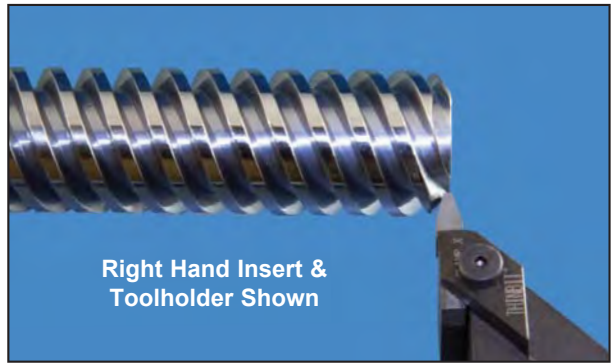

Right Hand Insert & Toolholder Shown

## MODIFICATIONS

SEE PAGE  
**8-3**  
FOR ADDITIONAL  
INFORMATION

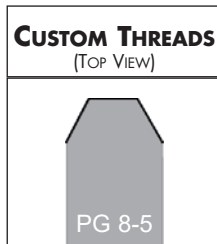
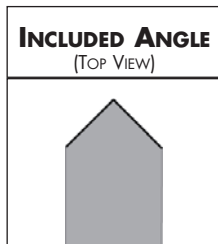

## CNC, SWISS, CONVENTIONAL STYLE

## ROUND STYLE

## TOOLHOLDER SELECTIONS

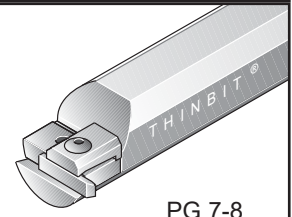
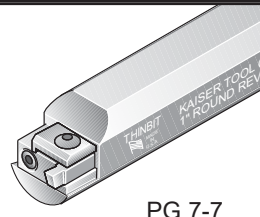
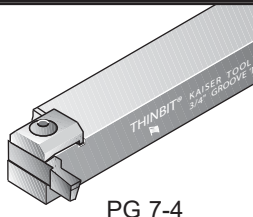
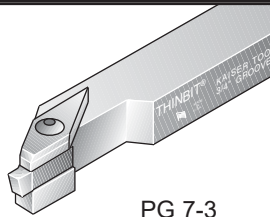

## PRODUCT DEMONSTRATION

## SPEEDS AND FEEDS

## APPLICATION REFERENCE

## TROUBLESHOOTING

## TECHNICAL SECTIONS



[www.thinbit.com/qr4-11](http://www.thinbit.com/qr4-11)

PG 9-18

PGS 9-3 & 9-4

PG 9-7

## KAISER TOOL COMPANY, INC.

Phone: 888-THINBIT (888-844-6248) or (260) 484-3620 • Fax: 888-THINFAX (888-844-6329) or (260) 482-1881  
www.thinbit.com • General E-mail: [thinbit@kaisertool.com](mailto:thinbit@kaisertool.com) • Orders: [orders@thinbit.com](mailto:orders@thinbit.com) • Quotes: [quotes@thinbit.com](mailto:quotes@thinbit.com)



# ACME THREADING INSERTS

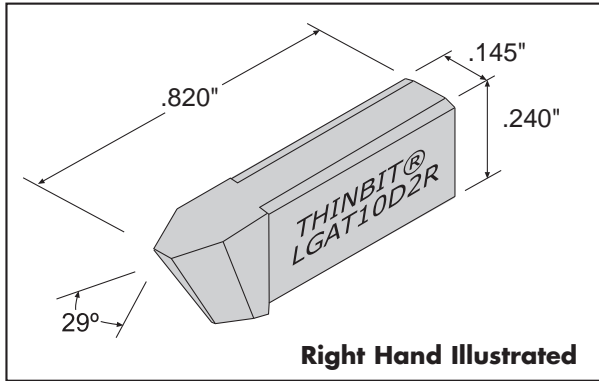

FRONT RAKE: 15°

TOP RAKE: 0°

- 29° ACME threading inserts for internal and external applications.
- ACME threading tools can be used to cut other thread profiles by over cutting.
- Single lead

## ORDERING INSTRUCTIONS

Select the **ORDER CODE** in the table below that represents your selection of orientation and insert grade.

**EXAMPLE:**

The **ORDER CODE** for a right hand ACME threading insert in **DURA-MAX® 2000** with 10 or fewer T.P.I. is:  
**LGAT10D2R**

ACME INSERTS  
THREADING





SPECIFICATIONS			ORDER CODE				INFO.			
Insert Orientation	Threads per Inch	Flat at Tip	Insert Grades See Page 9-5 for expanded material selections and Page 9-18 for Speeds and Feeds information			Coatings See page 9-6 for expanded coating descriptions Use Uncoated Part Number and Add Coating Code				Toolholder Catalog Section 7  Use Toolholders Beginning With
			DURA-MAX® 2000 Carbide For Steel & Interrupted Cutting	DURA-MAX® 5000 Carbide For Aluminum & Nonferrous	High Speed Steel	TIN	TICN	TIAlN	Diamond	
Centered right hand, left hand, internal and external threads	4	.087"	LGAT04D2R	LGAT04D5R	LGAT04HSR	add 'C'	add 'D'	add 'E'	add 'F'	'L'
	5	.069"	LGAT05D2R	LGAT05D5R	LGAT05HSR					
	6	.057"	LGAT06D2R	LGAT06D5R	LGAT06HSR					
	8	.041"	LGAT08D2R	LGAT08D5R	LGAT08HSR					
	10	.032"	LGAT10D2R	LGAT10D5R	LGAT10HSR					
	12	.028"	LGAT12D2R	LGAT12D5R	LGAT12HSR					
	14	.024"	LGAT14D2R	LGAT14D5R	LGAT14HSR					
	16	.021"	LGAT16D2R	LGAT16D5R	LGAT16HSR					
										Use right hand straight holder, or left hand 90° holder, for right hand external threads or left hand internal threads  or Use left hand straight holder, or right hand 90° holder, for left hand external threads or right hand internal threads

## KAISER TOOL COMPANY, INC.

Phone: 888-THINBIT (888-844-6248) or (260) 484-3620 • Fax: 888-THINFAX (888-844-6329) or (260) 482-1881  
www.thinbit.com • General E-mail: thinbit@kaisertool.com • Orders: orders@thinbit.com • Quotes: quotes@thinbit.com

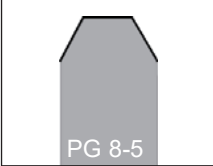
<b>PRODUCT INFORMATION</b>	<ul style="list-style-type: none"> <li>• Chamfering within .090" of a shoulder.</li> <li>• Internal chamfering with 1.250" minimum bore diameter.</li> <li>• Sub-micron grain <b>DURA-MAX<sup>®</sup> 2000</b> and <b>5000</b> Carbides and High Speed Steel.</li> <li>• Inserts can be coated with TiN, TiAlN, TiCN and Diamond coating.</li> </ul>
----------------------------	--

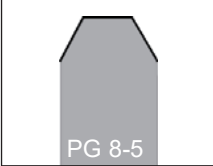

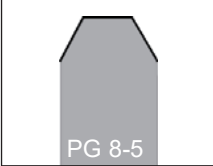
<b>MODIFICATIONS</b> SEE PAGE 8-3 FOR ADDITIONAL INFORMATION	<table border="1" style="width: 100%;"> <tr> <td style="width: 50%; text-align: center;"> <b>INCLUDED ANGLE</b> (TOP VIEW) </td> <td style="width: 50%; text-align: center;"> <b>CUSTOM THREADS</b> (TOP VIEW)  PG 8-5                 </td> </tr> </table>	<b>INCLUDED ANGLE</b> (TOP VIEW) 	<b>CUSTOM THREADS</b> (TOP VIEW)  PG 8-5
<b>INCLUDED ANGLE</b> (TOP VIEW) 	<b>CUSTOM THREADS</b> (TOP VIEW)  PG 8-5		

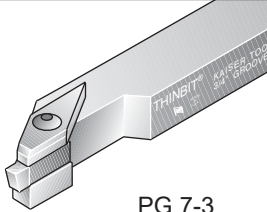
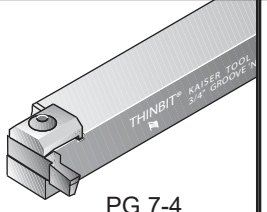
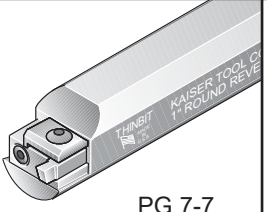
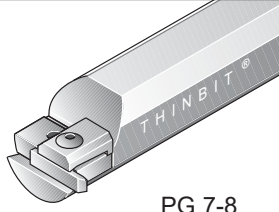
<b>TOOLHOLDER SELECTIONS</b>	<b>CNC, SWISS, CONVENTIONAL STYLE</b>		<b>ROUND STYLE</b>	
	 PG 7-3	 PG 7-4	 PG 7-7	 PG 7-8

<b>TECHNICAL SECTIONS</b>	<b>PRODUCT DEMONSTRATION</b>	<b>SPEEDS AND FEEDS</b>	<b>APPLICATION REFERENCE</b>	<b>TROUBLESHOOTING</b>
	 <a href="http://www.thinbit.com/qr4-13">www.thinbit.com/qr4-13</a>	PG 9-18	PGS 9-3 & 9-4	PG 9-7

## KAISER TOOL COMPANY, INC.

# CHAMFERING INSERTS

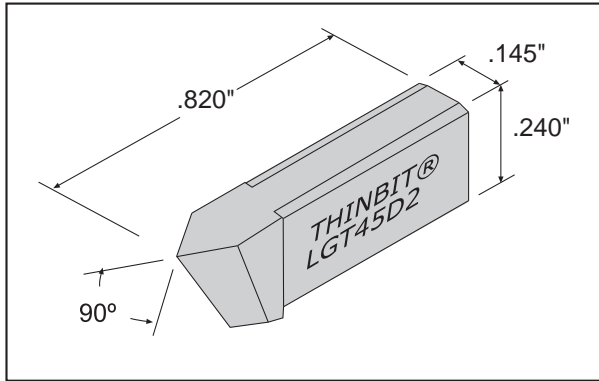

FRONT RAKE: 15°  
 MAXIMUM RADIUS: .002"  
 TOP RAKE: 0°

## ORDERING INSTRUCTIONS

Select the **ORDER CODE** in the table below that represents your selection of orientation and insert grade.

**EXAMPLE:**

The **ORDER CODE** for a chamfering insert in **DURA-MAX® 2000** is:

**LGT45D2**

CHAMFERING INSERTS  
THREADING

SPECIFICATIONS		ORDER CODE						INFO.	
Insert Orientation	Flat at Tip	Insert Grades <small>See Page 9-5 for expanded material selections and Page 9-18 for speeds and feeds information</small>			Coatings <small>See Page 9-6 for expanded coating descriptions</small>				Toolholder Catalog Section 7  Use Toolholders Beginning With
		DURA-MAX® 2000 Carbide <small>For Steel &amp; Interrupted Cutting</small>	DURA-MAX® 5000 Carbide <small>For Aluminum &amp; Nonferrous</small>	High Speed Steel	Use Uncoated Part Number and Add Coating Code				
					TiN	TiCN	TiAlN	Diamond	
Centered	None	LGT45D2	LGT45D5	LGT45HS	add 'C'	add 'D'	add 'E'	add 'F'	'L'

## KAISER TOOL COMPANY, INC.

PAGE  
5-3



- For diameters 1" and smaller
- Parting widths .025", .045", .062", .085" & .115"
- Typically used for Conventional and Swiss machining, precious metals and small diameter parts

PAGE  
1-13

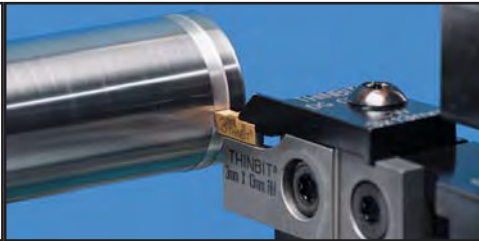

- For diameters 2" and smaller
- Parting widths 2, 3, 4, 5 and 6mm
- Typically used for CNC machining and large diameter parts

PARTING



Scan this code  
for additional  
information

[www.thinbit.com/qr5-1](http://www.thinbit.com/qr5-1)

# THINBIT®

OVER 100,000 TOOLS IN STOCK FOR  
GROOVING • THREADING • PARTING • BORING  
TURNING • FACE GROOVING  
SPECIALS • FORM TOOLS

**KAISER TOOL COMPANY, INC.**

Phone: 888-THINBIT (888-844-6248) or (260) 484-3620 • Fax: 888-THINFAX (888-844-6329) or (260) 482-1881  
[www.thinbit.com](http://www.thinbit.com) • General E-mail: [thinbit@kaisertool.com](mailto:thinbit@kaisertool.com) • Orders: [orders@thinbit.com](mailto:orders@thinbit.com) • Quotes: [quotes@thinbit.com](mailto:quotes@thinbit.com)

# TOOLING ORIENTATION GUIDE - PARTING

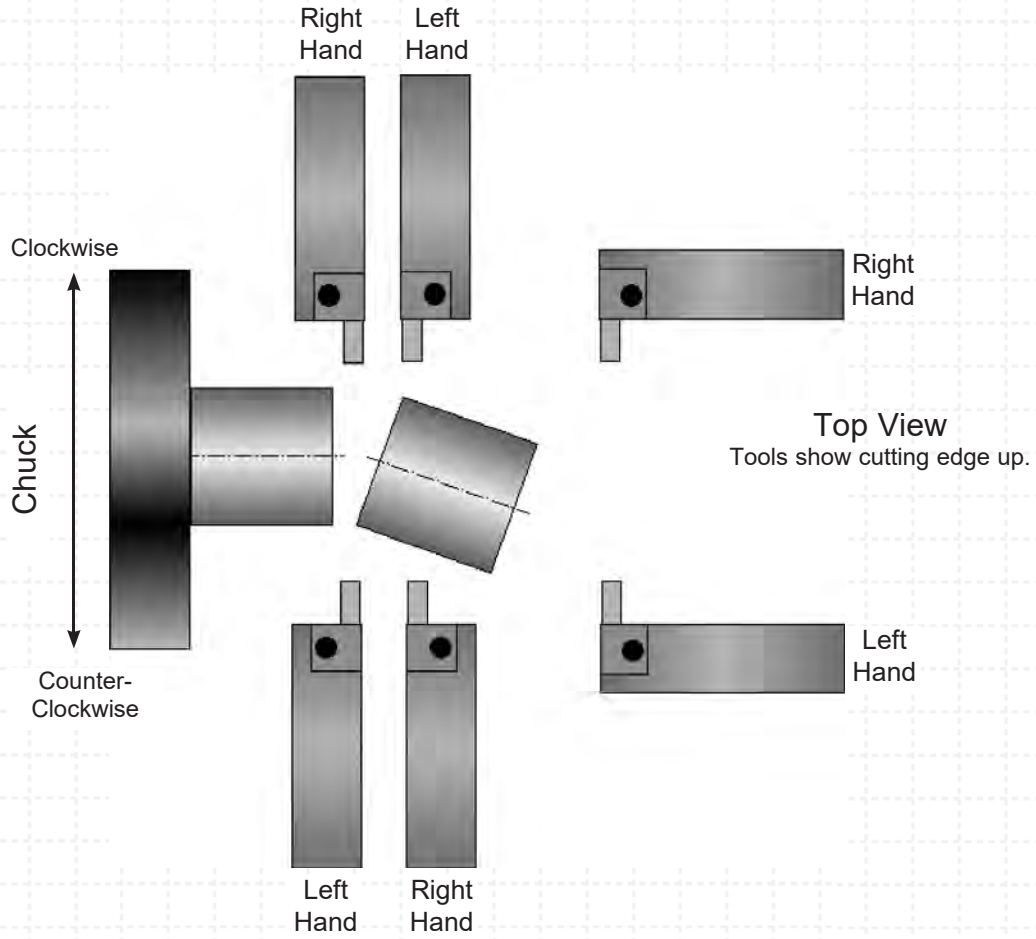

**PARTING**

## KAISER TOOL COMPANY, INC.

Phone: 888-THINBIT (888-844-6248) or (260) 484-3620 • Fax: 888-THINFAX (888-844-6329) or (260) 482-1881  
www.thinbit.com • General E-mail: [thinbit@kaisertool.com](mailto:thinbit@kaisertool.com) • Orders: [orders@thinbit.com](mailto:orders@thinbit.com) • Quotes: [quotes@thinbit.com](mailto:quotes@thinbit.com)



## PRODUCT INFORMATION

- .025", .045", .062", .085" and .115"
- Parting off up to 1" diameter
- 0° or 7° lead angle
- Centered or Offset
- Sub-micron grain **DURA-MAX<sup>®</sup> 2000** and **5000** Carbides and High Speed Steel.
- Inserts available with TiN, TiAlN, TiCN and Diamond coating.



## MODIFICATIONS

SEE PAGE 8-3 FOR ADDITIONAL INFORMATION

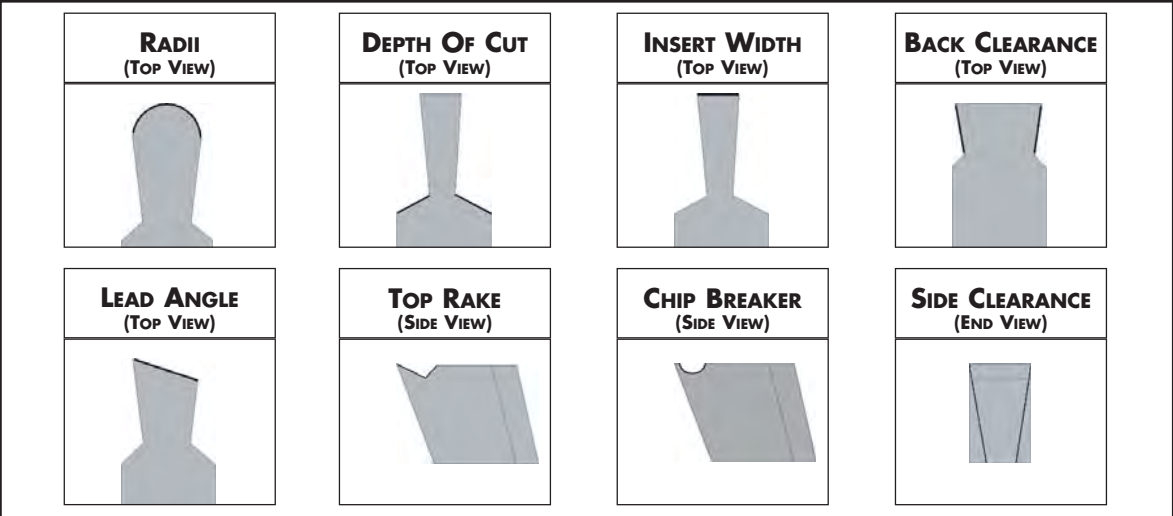

## TOOLHOLDER SELECTIONS

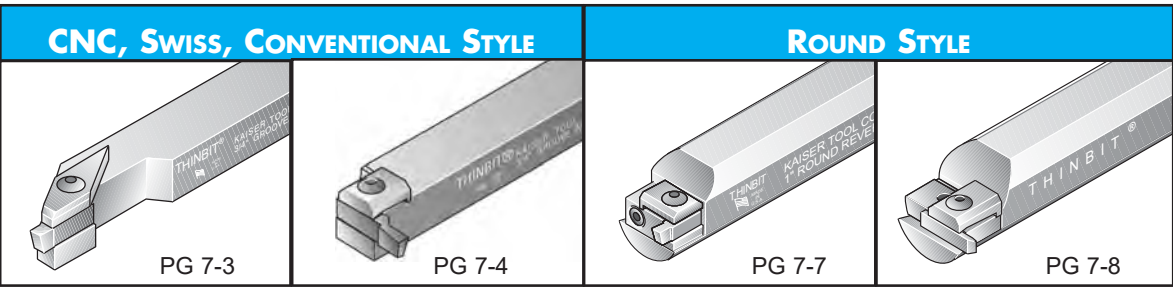

## TECHNICAL SECTIONS

PRODUCT DEMONSTRATION	SPEEDS AND FEEDS	APPLICATION REFERENCE	TROUBLESHOOTING
<p><a href="http://www.thinbit.com/qr5-3">www.thinbit.com/qr5-3</a></p>	PG 9-20	PGS 9-3 & 9-4	PG 9-7

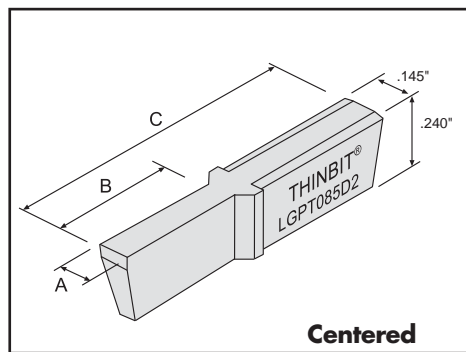

FRONT RAKE:  
 CARBIDE: Primary 7° honed, Secondary 15°  
 HIGH SPEED STEEL: 15°

BACK CLEARANCE:  
 0° LGPT045HS & LGPT062HS  
 1° all others

SIDE CLEARANCE: 1°

RADIUS: None

TOP RAKE: 0°

LEAD ANGLE: 0° or 7°

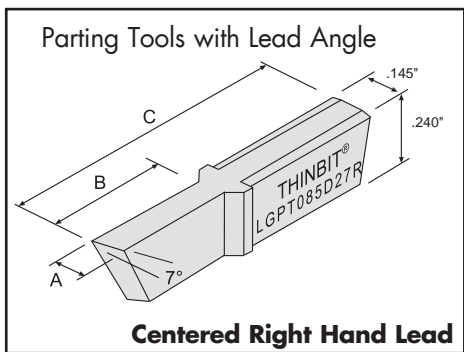

## KAISER TOOL COMPANY, INC.

# PARTING INSERTS















## ORDERING INSTRUCTIONS

Select the **ORDER CODE** in the table below that represents your selection of groove width and insert grade.

**EXAMPLE:**

The **ORDER CODE** for an .085" wide parting insert in **DURA-MAX® 2000** is:

**LGPT085D2**

SPECIFICATIONS				ORDER CODE				INFORMATION												
Insert Width  'A'  ±.001"	Insert Orientation	Lead Angle Orientation  Right Hand Left Hand	Depth of Cut  'B'	Insert Grades See Page 9-5 for expanded material descriptions and Page 9-20 for Speeds and Feeds information			Coatings See Page 9-6 for expanded coating descriptions				Overall Length  'C'	Toolholder Catalog Section 7  Use Toolholders Beginning With								
				DURA-MAX® 2000 Carbide For Steel & Interrupted Cutting	DURA-MAX® 5000 Carbide For Aluminum & Non-ferrous	High Speed Steel	TIN	TICN	TIAlN	Diamond										
.025"	Centered 	0°	.200"	LGPT025D2	LGPT025D5	LGPT025HS	add 'C'	add 'D'	add 'E'	add 'F'	.820" Carbide  .825" HSS	'L' Series  Centered Use any straight holder or 90° holder								
		7° Right Hand		LGPT025D27R	LGPT025D57R	LGPT025HS7R														
		7° Left Hand		LGPT025D27L	LGPT025D57L	LGPT025HS7L														
	Right Hand 	0°		LGPT025D2R	LGPT025D5R	LGPT025HSR														
		7° Right Hand		LGPT025D2R7R	LGPT025D5R7R	LGPT025HSR7R														
		7° Left Hand		LGPT025D2R7L	LGPT025D5R7L	LGPT025HSR7L														
	Left Hand 	0°		LGPT025D2L	LGPT025D5L	LGPT025HSL														
		7° Right Hand		LGPT025D2L7R	LGPT025D5L7R	LGPT025HSL7R														
		7° Left Hand		LGPT025D2L7L	LGPT025D5L7L	LGPT025HSL7L														
	.045"	Centered 		0°	.500"	LGPT045D2							LGPT045D5	LGPT045HS	add 'C'	add 'D'	add 'E'	add 'F'	1.062" Carbide  1.078" HSS	Right Hand Use right hand straight holder or left hand 90° holder
				7° Right Hand		LGPT045D27R							LGPT045D57R	LGPT045HS7R						
				7° Left Hand		LGPT045D27L							LGPT045D57L	LGPT045HS7L						
Right Hand 		0°	LGPT045D2R	LGPT045D5R		LGPT045HSR														
		7° Right Hand	LGPT045D2R7R	LGPT045D5R7R		LGPT045HSR7R														
		7° Left Hand	LGPT045D2R7L	LGPT045D5R7L		LGPT045HSR7L														
Left Hand 		0°	LGPT045D2L	LGPT045D5L		LGPT045HSL														
		7° Right Hand	LGPT045D2L7R	LGPT045D5L7R		LGPT045HSL7R														
		7° Left Hand	LGPT045D2L7L	LGPT045D5L7L		LGPT045HSL7L														
.062"		Centered 	0°	.500"		LGPT062D2	LGPT062D5	LGPT062HS	add 'C'	add 'D'	add 'E'	add 'F'	1.062" Carbide  1.078" HSS	Left Hand Use left hand straight holder or right hand 90° holder						
			7° Right Hand			LGPT062D27R	LGPT062D57R	LGPT062HS7R												
			7° Left Hand			LGPT062D27L	LGPT062D57L	LGPT062HS7L												
	Right Hand 	0°	LGPT062D2R		LGPT062D5R	LGPT062HSR														
		7° Right Hand	LGPT062D2R7R		LGPT062D5R7R	LGPT062HSR7R														
		7° Left Hand	LGPT062D2R7L		LGPT062D5R7L	LGPT062HSR7L														
	Left Hand 	0°	LGPT062D2L		LGPT062D5L	LGPT062HSL														
		7° Right Hand	LGPT062D2L7R		LGPT062D5L7R	LGPT062HSL7R														
		7° Left Hand	LGPT062D2L7L		LGPT062D5L7L	LGPT062HSL7L														
	.085"	Centered 	0°		.500"	LGPT085D2	LGPT085D5	LGPT085HS							add 'C'	add 'D'	add 'E'	add 'F'	1.062" Carbide  1.078" HSS	Left Hand Use left hand straight holder or right hand 90° holder
			7° Right Hand			LGPT085D27R	LGPT085D57R	LGPT085HS7R												
			7° Left Hand			LGPT085D27L	LGPT085D57L	LGPT085HS7L												
Right Hand 		0°	LGPT085D2R	LGPT085D5R		LGPT085HSR														
		7° Right Hand	LGPT085D2R7R	LGPT085D5R7R		LGPT085HSR7R														
		7° Left Hand	LGPT085D2R7L	LGPT085D5R7L		LGPT085HSR7L														
Left Hand 		0°	LGPT085D2L	LGPT085D5L		LGPT085HSL														
		7° Right Hand	LGPT085D2L7R	LGPT085D5L7R		LGPT085HSL7R														
		7° Left Hand	LGPT085D2L7L	LGPT085D5L7L		LGPT085HSL7L														
.115"		Centered 	0°	.500"		LGPT115D2	LGPT115D5	LGPT115HS	add 'C'	add 'D'	add 'E'	add 'F'	1.062" Carbide  1.078" HSS	Left Hand Use left hand straight holder or right hand 90° holder						
			7° Right Hand			LGPT115D27R	LGPT115D57R	LGPT115HS7R												
			7° Left Hand			LGPT115D27L	LGPT115D57L	LGPT115HS7L												
	Right Hand 	0°	LGPT115D2R		LGPT115D5R	LGPT115HSR														
		7° Right Hand	LGPT115D2R7R		LGPT115D5R7R	LGPT115HSR7R														
		7° Left Hand	LGPT115D2R7L		LGPT115D5R7L	LGPT115HSR7L														
	Left Hand 	0°	LGPT115D2L		LGPT115D5L	LGPT115HSL														
		7° Right Hand	LGPT115D2L7R		LGPT115D5L7R	LGPT115HSL7R														
		7° Left Hand	LGPT115D2L7L		LGPT115D5L7L	LGPT115HSL7L														

INSERTS PARTING

**PRODUCT INFORMATION**

- 2, 3, 4, 5 and 6mm insert widths.
- Recessed pocket and raised edge for chip control.
- Internal grooving, external grooving, face grooving and parting.
- Sub-micron grain **DURA-MAX® 2000** carbide.
- Inserts available with TiN, TiAlN, TiCN and Diamond coating.

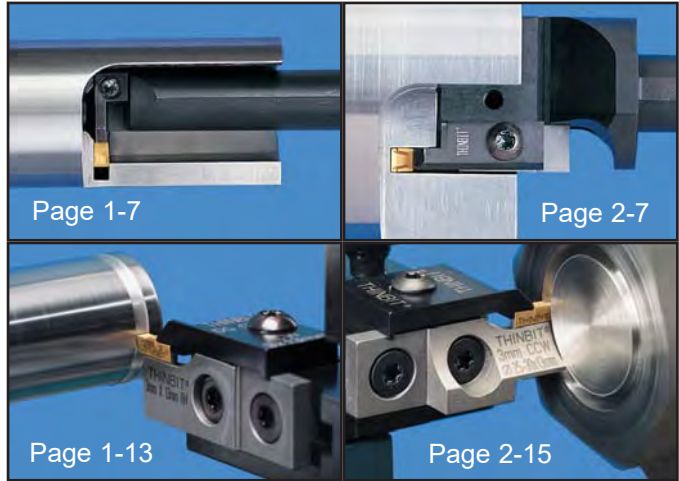

**INSERT GEOMETRY**

<p><b>SHARP CORNER (TOP VIEW)</b></p>	<p><b>CORNER RADIUS (TOP VIEW)</b></p>	<p><b>FULL RADIUS (TOP VIEW)</b></p>	<p><b>60° THREADING (TOP VIEW)</b></p>
<p><b>7° LEAD ANGLE (TOP VIEW)</b></p> <p>Right Hand    Left Hand</p>	<p><b>15°(+) TOP RAKE (SIDE VIEW)</b></p>	<p><b>15° (-) TOP RAKE (SIDE VIEW)</b></p>	<p><b>90° CHAMFERING (TOP VIEW)</b></p>

TECHNICAL SECTIONS	PRODUCT DEMONSTRATION	SPEEDS AND FEEDS	APPLICATION REFERENCE	TROUBLESHOOTING
	 <a href="http://www.thinbit.com/qr6-1">www.thinbit.com/qr6-1</a>	PGS 9-10, 9-12, 9-18 & 9-20	PGS 9-3 & 9-4	PG 9-7

## ORDERING INSTRUCTIONS

Select the **ORDER CODE** in the table at right that represents your selection of insert geometry and coating. Please pay special attention to the '**Compatibility**' column to match the insert with the correct tooling.

The **ORDER CODE** for a 3mm wide, '**DGI**' Style insert with .015" radius and TiN coating is '**DGI 30BC**'

### KAISER TOOL COMPANY, INC.

# 'DGI' & 'DGMI' STYLE OD/ID AND FACE GROOVING INSERTS

SPECIFICATIONS			ORDER CODE						
Insert Width +.005"/ -.000"	Compatibility	Insert Geometry	DURA-MAX® 2000 Carbide See Page 9-10 or 9-12 for Speeds and Feeds						
			Uncoated	TiN	TiCN Non-stock	TiAlN	Diamond Non-stock		
.078" (2mm)	Use in all 2mm 'DGP'	Sharp Corner	DGI20BU1	DGI20BC1	DGI20BD1	DGI20BE1	DGI20BF1		
		.004" (.10mm) radius	DGI20BU2010	DGI20BC2010	DGI20BD2010	DGI20BE2010	DGI20BF2010		
		.008" (.20mm) radius	DGI20BU2020	DGI20BC2020	DGI20BD2020	DGI20BE2020	DGI20BF2020		
		.010" (.25mm) radius	DGI20BU2025	DGI20BC2025	DGI20BD2025	DGI20BE2025	DGI20BF2025		
		.015" (.38mm) radius	DGI20BU	DGI20BC	DGI20BD	DGI20BE	DGI20BF		
		.020" (.50mm) radius	DGI20BU2050	DGI20BC2050	DGI20BD2050	DGI20BE2050	DGI20BF2050		
		.030" (.75mm) radius	DGI20BU2075	DGI20BC2075	DGI20BD2075	DGI20BE2075	DGI20BF2075		
		Full Radius	DGI20BU4	DGI20BC4	DGI20BD4	DGI20BE4	DGI20BF4		
		15° (+) Top Rake	DGI20BU7P	DGI20BC7P	DGI20BD7P	DGI20BE7P	DGI20BF7P		
		15° (-) Top Rake	DGI20BU7N	DGI20BC7N	DGI20BD7N	DGI20BE7N	DGI20BF7N		
		7° R.H. Lead Angle	DGI20BU3R	DGI20BC3R	DGI20BD3R	DGI20BE3R	DGI20BF3R		
		7° L.H. Lead Angle	DGI20BU3L	DGI20BC3L	DGI20BD3L	DGI20BE3L	DGI20BF3L		
		.118" (3mm)	Use ONLY with 3mm 'DGPZ' ID tools and face grooving heads with major diameter codes '02' and '25'	Sharp Corner	DGMI30BU1	DGMI30BC1	DGMI30BD1	DGMI30BE1	DGMI30BF1
				.015" (.38mm) radius	DGMI30BU	DGMI30BC	DGMI30BD	DGMI30BE	DGMI30BF
Use in 3mm 'DGP' for OD grooving/parting and major diameters greater than .984"	Sharp Corner		DGI30BU1	DGI30BC1	DGI30BD1	DGI30BE1	DGI30BF1		
	.004" (.10mm) radius		DGI30BU2010	DGI30BC2010	DGI30BD2010	DGI30BE2010	DGI30BF2010		
	.008" (.20mm) radius		DGI30BU2020	DGI30BC2020	DGI30BD2020	DGI30BE2020	DGI30BF2020		
	.010" (.25mm) radius		DGI30BU2025	DGI30BC2025	DGI30BD2025	DGI30BE2025	DGI30BF2025		
	.015" (.38mm) radius		DGI30BU	DGI30BC	DGI30BD	DGI30BE	DGI30BF		
	.020" (.50mm) radius		DGI30BU2050	DGI30BC2050	DGI30BD2050	DGI30BE2050	DGI30BF2050		
	.030" (.75mm) radius		DGI30BU2075	DGI30BC2075	DGI30BD2075	DGI30BE2075	DGI30BF2075		
	.040" (1.0mm) radius		DGI30BU2100	DGI30BC2100	DGI30BD2100	DGI30BE2100	DGI30BF2100		
	Full Radius		DGI30BU4	DGI30BC4	DGI30BD4	DGI30BE4	DGI30BF4		
	15° (+) Top Rake		DGI30BU7P	DGI30BC7P	DGI30BD7P	DGI30BE7P	DGI30BF7P		
	15° (-) Top Rake		DGI30BU7N	DGI30BC7N	DGI30BD7N	DGI30BE7N	DGI30BF7N		
	7° R.H. Lead Angle		DGI30BU3R	DGI30BC3R	DGI30BD3R	DGI30BE3R	DGI30BF3R		
	7° L.H. Lead Angle		DGI30BU3L	DGI30BC3L	DGI30BD3L	DGI30BE3L	DGI30BF3L		
	60° Threading		DGI30BU5	DGI30BC5	DGI30BD5	DGI30BE5	DGI30BF5		
	90° Chamfering		DGI30BU6	DGI30BC6	DGI30BD6	DGI30BE6	DGI30BF6		
	.157" (4mm)		Use ONLY with 4mm 'DGPZ' ID tools and face grooving heads with major diameter codes '02' and '25'	Sharp Corner	DGMI40BU1	DGMI40BC1	DGMI40BD1	DGMI40BE1	DGMI40BF1
.015" (.38mm) radius		DGMI40BU		DGMI40BC	DGMI40BD	DGMI40BE	DGMI40BF		
Use in 4mm 'DGP' for OD grooving/parting and major diameters greater than .984"		Sharp Corner	DGI40BU1	DGI40BC1	DGI40BD1	DGI40BE1	DGI40BF1		
		.004" (.10mm) radius	DGI40BU2010	DGI40BC2010	DGI40BD2010	DGI40BE2010	DGI40BF2010		
		.008" (.20mm) radius	DGI40BU2020	DGI40BC2020	DGI40BD2020	DGI40BE2020	DGI40BF2020		
		.010" (.25mm) radius	DGI40BU2025	DGI40BC2025	DGI40BD2025	DGI40BE2025	DGI40BF2025		
		.015" (.38mm) radius	DGI40BU	DGI40BC	DGI40BD	DGI40BE	DGI40BF		
		.020" (.50mm) radius	DGI40BU2050	DGI40BC2050	DGI40BD2050	DGI40BE2050	DGI40BF2050		
		.030" (.75mm) radius	DGI40BU2075	DGI40BC2075	DGI40BD2075	DGI40BE2075	DGI40BF2075		
		.040" (1.0mm) radius	DGI40BU2100	DGI40BC2100	DGI40BD2100	DGI40BE2100	DGI40BF2100		
		Full Radius	DGI40BU4	DGI40BC4	DGI40BD4	DGI40BE4	DGI40BF4		
		15° (+) Top Rake	DGI40BU7P	DGI40BC7P	DGI40BD7P	DGI40BE7P	DGI40BF7P		
		15° (-) Top Rake	DGI40BU7N	DGI40BC7N	DGI40BD7N	DGI40BE7N	DGI40BF7N		
		7° R.H. Lead Angle	DGI40BU3R	DGI40BC3R	DGI40BD3R	DGI40BE3R	DGI40BF3R		
		7° L.H. Lead Angle	DGI40BU3L	DGI40BC3L	DGI40BD3L	DGI40BE3L	DGI40BF3L		
		.197" (5mm)	Use in all 5mm 'DGP'	Sharp Corner	DGI50BU1	DGI50BC1	DGI50BD1	DGI50BE1	DGI50BF1
				.004" (.10mm) radius	DGI50BU2010	DGI50BC2010	DGI50BD2010	DGI50BE2010	DGI50BF2010
				.008" (.20mm) radius	DGI50BU2020	DGI50BC2020	DGI50BD2020	DGI50BE2020	DGI50BF2020
.010" (.25mm) radius	DGI50BU2025			DGI50BC2025	DGI50BD2025	DGI50BE2025	DGI50BF2025		
.015" (.38mm) radius	DGI50BU			DGI50BC	DGI50BD	DGI50BE	DGI50BF		
.020" (.50mm) radius	DGI50BU2050			DGI50BC2050	DGI50BD2050	DGI50BE2050	DGI50BF2050		
.030" (.75mm) radius	DGI50BU2075			DGI50BC2075	DGI50BD2075	DGI50BE2075	DGI50BF2075		
.040" (1.0mm) radius	DGI50BU2100			DGI50BC2100	DGI50BD2100	DGI50BE2100	DGI50BF2100		
Full Radius	DGI50BU4			DGI50BC4	DGI50BD4	DGI50BE4	DGI50BF4		
15° (+) Top Rake	DGI50BU7P			DGI50BC7P	DGI50BD7P	DGI50BE7P	DGI50BF7P		
15° (-) Top Rake	DGI50BU7N			DGI50BC7N	DGI50BD7N	DGI50BE7N	DGI50BF7N		
7° R.H. Lead Angle	DGI50BU3R			DGI50BC3R	DGI50BD3R	DGI50BE3R	DGI50BF3R		
7° L.H. Lead Angle	DGI50BU3L			DGI50BC3L	DGI50BD3L	DGI50BE3L	DGI50BF3L		
.236" (6mm)	Use in all 6mm 'DGP'			Sharp Corner	DGI60BU1	DGI60BC1	DGI60BD1	DGI60BE1	DGI60BF1
		.004" (.10mm) radius	DGI60BU2010	DGI60BC2010	DGI60BD2010	DGI60BE2010	DGI60BF2010		
		.008" (.20mm) radius	DGI60BU2020	DGI60BC2020	DGI60BD2020	DGI60BE2020	DGI60BF2020		
		.010" (.25mm) radius	DGI60BU2025	DGI60BC2025	DGI60BD2025	DGI60BE2025	DGI60BF2025		
		.015" (.38mm) radius	DGI60BU	DGI60BC	DGI60BD	DGI60BE	DGI60BF		
		.020" (.50mm) radius	DGI60BU2050	DGI60BC2050	DGI60BD2050	DGI60BE2050	DGI60BF2050		
		.030" (.75mm) radius	DGI60BU2075	DGI60BC2075	DGI60BD2075	DGI60BE2075	DGI60BF2075		
		.040" (1.0mm) radius	DGI60BU2100	DGI60BC2100	DGI60BD2100	DGI60BE2100	DGI60BF2100		
		Full Radius	DGI60BU4	DGI60BC4	DGI60BD4	DGI60BE4	DGI60BF4		
		15° (+) Top Rake	DGI60BU7P	DGI60BC7P	DGI60BD7P	DGI60BE7P	DGI60BF7P		
		15° (-) Top Rake	DGI60BU7N	DGI60BC7N	DGI60BD7N	DGI60BE7N	DGI60BF7N		
		7° R.H. Lead Angle	DGI60BU3R	DGI60BC3R	DGI60BD3R	DGI60BE3R	DGI60BF3R		
		7° L.H. Lead Angle	DGI60BU3L	DGI60BC3L	DGI60BD3L	DGI60BE3L	DGI60BF3L		

DGI STYLE  
OD/ID & FACE GROOVING  
INSERTS



Scan this code for additional information.

www.thinbit.com/qr7-1

**ADAPTERS**

**Adapters**

- square and round adapters
- Use for boring bars and solid carbide tooling

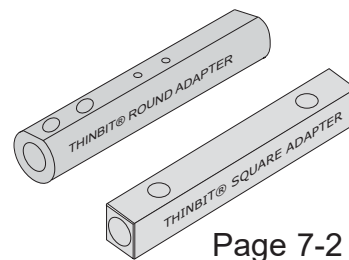

Page 7-2

**SWISS, CNC & CONVENTIONAL STYLE**

**Straight Square**

- 5/16", 3/8", 1/2", 5/8", 3/4", 1", 1-1/4" and metric shanks
- Right and Left Hand
- Use for grooving, face grooving, profiling, threading and parting

**90° Square**

- 5/16", 3/8", 1/2", 5/8", 3/4", 1", 1-1/4" and metric shanks
- Right and Left Hand
- Use for grooving, face grooving, profiling, threading and parting

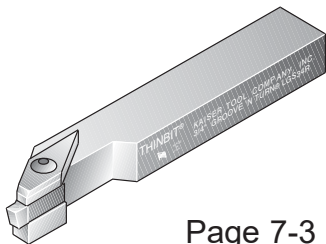

Page 7-3

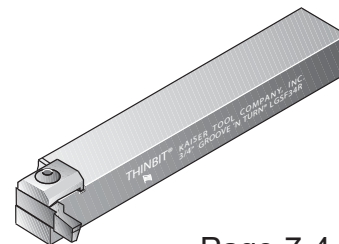

Page 7-4

**SWISS STYLE**

**Swiss Straight**

- 3/8", 1/2", 10mm, 12mm & 16 mm square shanks
- Right and Left Hand
- Use for OD grooving

**Swiss Face**

- 3/8", 1/2", 10mm, 12mm & 16mm square shanks
- Right Hand
- Use for face grooving

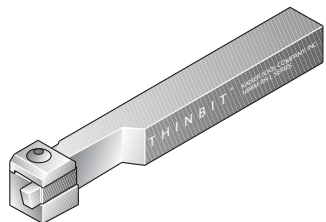

Page 7-5

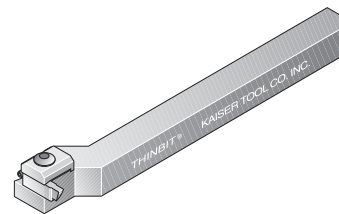

Page 7-6

**ROUND STYLE**

**Reversible**

- 1/2", 5/8", 3/4" & 1" shanks
- Right and Left Hand
- Use for grooving, face grooving, profiling, threading and parting

**Internal**

- 1/2", 5/8", 3/4" & 1" shanks
- Right and Left Hand
- Use for grooving, face grooving, profiling, threading and parting

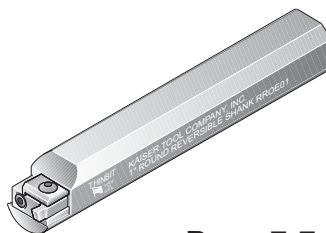

Page 7-7

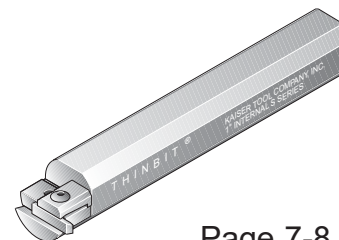

Page 7-8

**MULTI-INSERT STYLE**

**Square**

- 3/8", 1/2", 5/8", 3/4" & 1" shanks
- 1" & 2" pockets
- Use for grooving

**Round**

- 1" shank
- 1" pocket
- Use for grooving

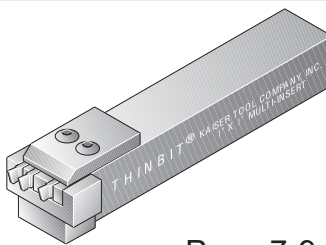

Page 7-9

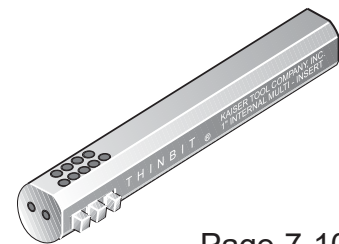

Page 7-10

**UNDERCUT STYLE**

**30°/60°/45° Square**

- 3/8", 1/2", 5/8", 3/4" and 1" shanks
- Right and Left Hand
- Use for making undercuts and profiling

**ALTERNATE DGP**

**Round & Square**

- Alternate combinations of Deepgroove® heads and shanks
- OD/ID grooving
- Face grooving

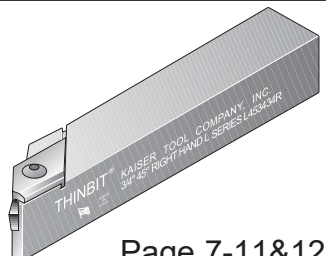

Page 7-11&12

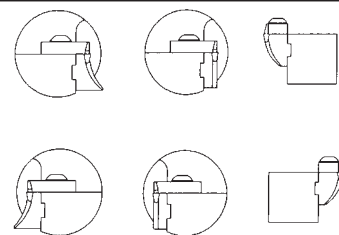

Page 7-13 & 14

**KAISER TOOL COMPANY, INC.**



# ROUND & SQUARE ADAPTERS

## PRODUCT INFORMATION

- Designed to adapt round tooling to lathe workholding
- ID sizes 1/8", 5/32", 3/16", 1/4", 5/16" and 3/8".
- Round sizes 1/4", 3/8", 1/2", 5/8" and 3/4".
- Square sizes 5/16", 3/8", 1/2", 5/8", 3/4", 1" and 1-1/4".
- Modifications can be provided on any of our tooling. Please contact us with your application requirements.

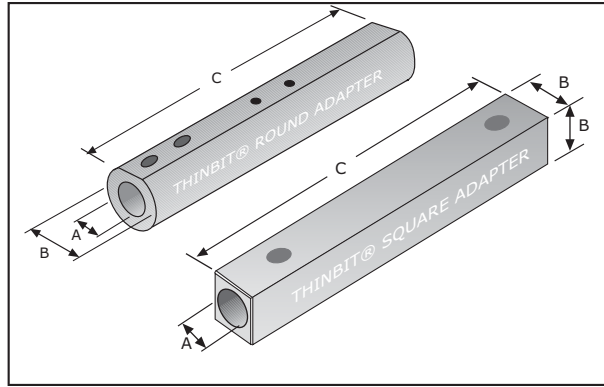

## TOOL SELECTIONS

### SOLID CARBIDE

- Grooving Page 1-3
- Face Grooving Page 2-3
- Boring Page 3-3
- Threading Page 4-3 & 4-5



### GROOVING BARS

- Grooving Page 1-5
- Face Grooving Page 2-5

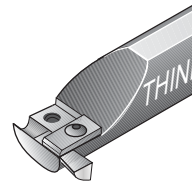

### BORING BARS

- MBA Page 3-13
- MBB Page 3-15
- MBC Page 3-17
- MBE Page 3-8
- MBF Page 3-9
- MBG Page 3-10

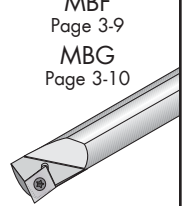

Scan this code for additional information.

[www.thinbit.com/qr7-2](http://www.thinbit.com/qr7-2)

## ORDERING INSTRUCTIONS

Select the **ORDER CODE** in the table below that represents your selection of adapter dimensions.

### EXAMPLE:

The **ORDER CODE** for a .375" ID x .625" OD round adapter is:  
**AD3762**

SPECIFICATIONS				ORDER CODE				SPECIFICATIONS				ORDER CODE			
Adapter Style	Shank Dimensions			Adapter	Replacement Parts			Adapter Style	Shank Dimensions			Adapter	Replacement Parts		
	'A'	'B'	'C'		Includes Adapter and Hardware	Screw	Wrench		Pin	'A'	'B'		'C'	Includes Adapter and Hardware	Screw
Round	.125"	.250"	3.000"	AD1225	S1402M	W0050	P0203	Round	.312"	.500"	4.000"	AD3150	S1802	W1005	P0204
				AD1237	S1402	W0050	P0203			.625"		AD3162	S1802	W1005	P0206
				AD1250	S1402	W0050	P0204			.750"		AD3175	S1802	W1005	P0206
				AD1262	S1404	W0050	P0204			1.000"		AD3110	S1804	W1005	P0206
				AD1275	S1404	W0050	P0204		.375"	.625"	AD3762	S1802	W1005	P0206	
				AD1210	S1404	W0050	P0204			.750"	AD3775	S1802	W1005	P0206	
	.156"	.375"	3.000"	AD1537	S1402M	W0050	---	Round	.500"	.750"	4.000"	AD3710	S1804	W1005	P0206
				AD1550	S1402	W0050	---					AD5075	S1802	W1005	P0206
				AD1562	S1403	W0050	---					AD5010	S1804	W1005	P0206
	.187"	.375"	3.000"	AD1837	S1402M	W0050	P0203	Round	.750"	1.000"	4.000"	AD7510	S1802	W1005	---
				AD1850	S1802	W1005	P0204								
				AD1862	S1802	W1005	P0206								
				AD1875	S1804	W1005	P0206								
	.250"	.625"	4.000"	AD1810	S1404	W0050	P0206	Square	.250"	.312"	3.000"	AD56	---	---	---
				AD2537	S1402M	W0050	P0203			.375"		AD38	S1802	W1005	---
				AD2550	S1802	W1005	P0204		.250" & .375"	.500"	AD12	S1802	W1005	---	
				AD2562	S1802	W1005	P0206			.625"	AD58	S1802	W1005	---	
				AD2575	S1804	W1005	P0206			.750"	AD34	S1802	W1005	---	
	AD2510	S1804	W1005	P0206	1.000"	AD01	S1802	W1005	---						
									1.250"		AD14	S1802	W1005	---	

TOOLHOLDERS

## KAISER TOOL COMPANY, INC.

Phone: 888-THINBIT (888-844-6248) or (260) 484-3620 • Fax: 888-THINFAX (888-844-6329) or (260) 482-1881  
www.thinbit.com • General E-mail: [thinbit@kaisertool.com](mailto:thinbit@kaisertool.com) • Orders: [orders@thinbit.com](mailto:orders@thinbit.com) • Quotes: [quotes@thinbit.com](mailto:quotes@thinbit.com)

## PRODUCT INFORMATION

- Designed for CNC, conventional and top slide position on Swiss screw machines.
- Shank sizes 5/16", 3/8", 1/2", 5/8", 3/4", 1" and 1-1/4". Metric sizes also available.
- Modifications can be provided on any of our tooling. Please contact us with your application requirements.

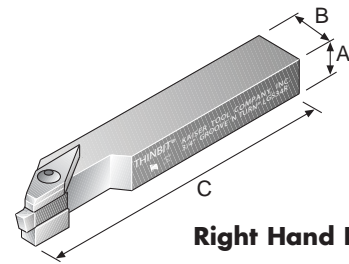

Right Hand Illustrated

## INSERT SELECTIONS

### GROOVING

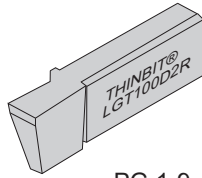

PG 1-9

### FACE GROOVING

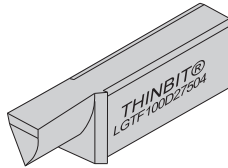

PG 2-9

### THREADING

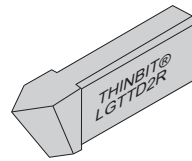

PG 4-9

### PARTING

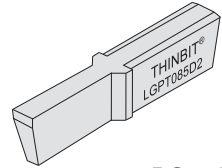

PG 5-3



Scan this code for additional information.

[www.thinbit.com/qr7-3](http://www.thinbit.com/qr7-3)

## ORDERING INSTRUCTIONS

Select the **ORDER CODE** in the table below that represents your selection of shank dimensions.

### EXAMPLE:

The **ORDER CODE** for a .750" Right Hand square shank for inserts beginning with 'L' is:

**LGS34R**

SPECIFICATIONS				ORDER CODE					
Shank Orientation	Shank Dimensions			Toolholder Package Includes Shank, Clamp and Hardware		Replacement Parts			
	'A'	'B'	'C'	For Inserts Beginning With 'L'		Clamp	Screw	Wrench	Pin
RIGHT HAND	LEFT HAND								
Straight  Use right hand holder with right hand inserts  Use left hand holder with left hand inserts	.312"	.500"	4.840"	LGS56R	LGS56L	Right Hand: Clamp X  Left Hand: Clamp Y	S3808	W1005	P0206
	.375"	.500"	4.840"	LGS38R	LGS38L				
	.500"	.500"	4.840"	LGS12R	LGS12L				
	.625"	.625"	4.840"	LGS58R	LGS58L				
	.750"	.750"	4.840"	LGS34R	LGS34L				
	1.000"	1.000"	4.840"	LGS01R	LGS01L				
	1.250"	1.250"	4.840"	LGS14R	LGS14L				
	8mm	.500"	4.840"	LGS08RM	LGS08LM				
	10mm	.500"	4.840"	LGS10RM	LGS10LM				
	12mm	.500"	4.840"	LGS12RM	LGS12LM				
	16mm	.750"	4.840"	LGS16RM	LGS16LM				
	20mm	1.000"	4.840"	LGS20RM	LGS20LM				
25mm	1.000"	4.840"	LGS25RM	LGS25LM					

## KAISER TOOL COMPANY, INC.

**PRODUCT INFORMATION**

- Designed for CNC and conventional machines.
- Shank sizes 5/16", 3/8", 1/2", 5/8", 3/4", 1" and 1-1/4". Metric sizes also available.
- Modifications can be provided on any of our tooling. Please contact us with your application requirements.

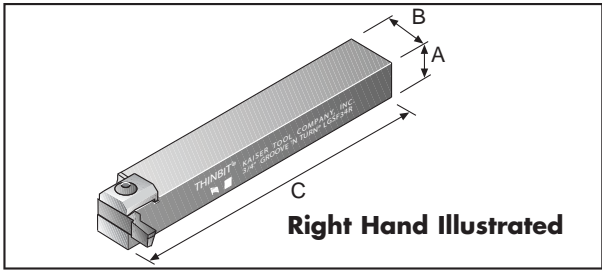

**INSERT SELECTIONS**

GROOVING	FACE GROOVING	THREADING	PARTING
PG 1-9	PG 2-9	PG 4-9	PG 5-3



Scan this code for additional information.

[www.thinbit.com/qr7-4](http://www.thinbit.com/qr7-4)

**ORDERING INSTRUCTIONS**

Select the **ORDER CODE** in the table below that represents your selection of shank orientation and dimensions.

**EXAMPLE:**

The **ORDER CODE** for a .750" right hand shank for inserts beginning with 'L' is:  
**LGSF34R**

SPECIFICATIONS				ORDER CODE					
Shank Orientation	Shank Dimensions			Toolholder Package Includes Shank, Clamp and Hardware For Inserts Beginning With 'L'		Replacement Parts			
	'A'	'B'	'C'	RIGHT HAND	LEFT HAND	Clamp	Screw	Wrench	Pin
90° Use right hand holder with left hand inserts	.312"	.500"	4.840"	LGSF56R		Clamp C	S3808	W1005	P0312
	.375"	.500"	4.840"	LGSF38R					
	.500"	.500"	4.840"	LGSF12R					
	.625"	.625"	4.840"	LGSF58R	LGSF58L				
	.750"	.750"	4.840"	LGSF34R	LGSF34L				
	1.000"	1.000"	4.840"	LGSF01R	LGSF01L				
	1.250"	1.250"	4.840"	LGSF14R	LGSF14L				
Use left hand holder with right hand inserts	8mm	.500"	4.840"	LGSF08RM					
	10mm	.500"	4.840"	LGSF10RM					
	12mm	.500"	4.840"	LGSF12RM					
	16mm	.750"	4.840"	LGSF16RM	LGSF16LM				
	20mm	1.000"	4.840"	LGSF20RM	LGSF20LM				
	25mm	1.000"	4.840"	LGSF25RM	LGSF25LM				

**GROOVE 'N TURN**®  
**TOOLHOLDERS**

**KAISER TOOL COMPANY, INC.**

Phone: 888-THINBIT (888-844-6248) or (260) 484-3620 • Fax: 888-THINFAX (888-844-6329) or (260) 482-1881  
www.thinbit.com • General E-mail: [thinbit@kaisertool.com](mailto:thinbit@kaisertool.com) • Orders: [orders@thinbit.com](mailto:orders@thinbit.com) • Quotes: [quotes@thinbit.com](mailto:quotes@thinbit.com)

**PRODUCT INFORMATION**

- Designed for top slide position on Swiss screw machines.
- Shank sizes 1/2", 12mm and 16mm in right hand orientation.
- Modifications can be provided on any of our tooling. Please contact us with your application requirements.

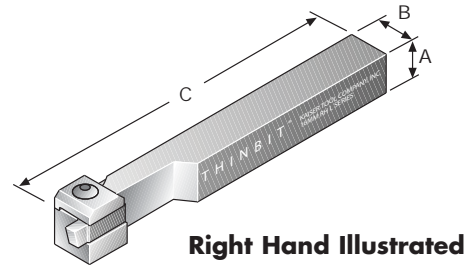

**INSERT SELECTIONS**

**GROOVING**

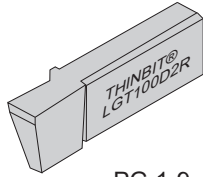

PG 1-9

**THREADING**

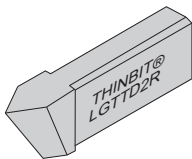

PG 4-9

**PARTING**

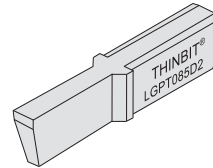

PG 5-3



Scan this code for additional information.

[www.thinbit.com/qr7-5](http://www.thinbit.com/qr7-5)

**ORDERING INSTRUCTIONS**

Select the **ORDER CODE** in the table below that represents your selection of shank orientation and dimensions.

**EXAMPLE:**

The **ORDER CODE** for a .500" shank, right hand tool for inserts beginning with 'L' is:  
**LSS12R**

SPECIFICATIONS				ORDER CODE				
Shank Orientation	Shank Dimensions			Toolholder Package Includes Shank, Clamp and Hardware  For Inserts Beginning With  'L'	Replacement Parts			
	'A'	'B'	'C'		Clamp	Screw	Wrench	Pin
Right Hand	.500"	.500"	4.840"	LSS12R	Clamp C	S3808	W1005	P0305
Use with right hand and centered inserts	12mm	12mm		LSS12RM				
	16mm	16mm		LSS16RM				
Left Hand	.500"	.500"	4.840"	LSS12L				
Use with left hand and centered inserts	12mm	12mm		LSS12LM				
	16mm	16mm		LSS16LM				

**KAISER TOOL COMPANY, INC.**

**PRODUCT INFORMATION**

- Designed for top slide position on Swiss screw machines.
- Shank sizes 3/8", 1/2", 10mm, 12mm and 16mm in right hand orientation.
- Modifications can be provided on any of our tooling. Please contact us with your application requirements.

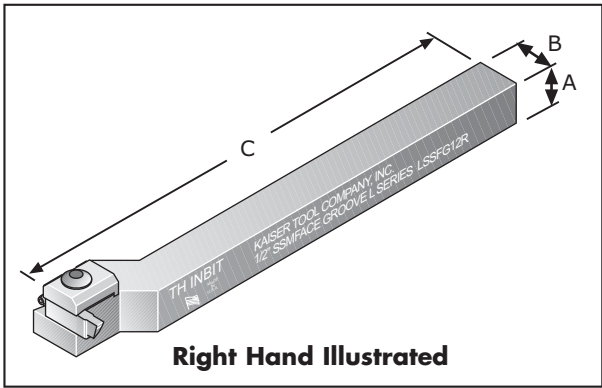

**INSERT SELECTIONS**

**FACE GROOVING**

PG 2-9



Scan this code for additional information.

[www.thinbit.com/qr7-6](http://www.thinbit.com/qr7-6)

**ORDERING INSTRUCTIONS**

Select the **ORDER CODE** in the table below that represents your selection of shank orientation and dimensions.

**EXAMPLE:**

The **ORDER CODE** for a .375" Right Hand shank for inserts beginning with 'L' is:

**LSSFG38R**

SPECIFICATIONS				ORDER CODE				
Shank Orientation	Shank Dimensions			Toolholder Package Includes Shank, Clamp and Hardware  For Inserts Beginning With 'L'	Replacement Parts			
	'A'	'B'	'C'		Clamp	Screw	Wrench	Pin
Right Hand  Use with left hand and centered inserts for counter-clockwise rotation	.375"	.375"	4.840"	LSSFG38R	Clamp C	S3808	W1005	P0203
	.500"	.500"	4.840"	LSSFG12R				
	10mm	10mm	4.840"	LSSFG10RM				
	12mm	12mm	4.840"	LSSFG12RM				
	16mm	16mm	4.840"	LSSFG16RM				

**SWISS TOOLHOLDERS**

**KAISER TOOL COMPANY, INC.**



**PRODUCT INFORMATION**

- Designed for boring bar positions on all machines.
- Can be used with a boring head to trepan on a mill. Shank may need to be shortened.
- Toolholder reversible by removing face and bottom screws and rotating head 1/2 turn.
- Shank sizes 1/2", 5/8", 3/4" and 1".
- All 1/2", 5/8" and 3/4" shanks are made from 1" shank.
- Modifications can be provided on any of our tooling. Please contact us with your application requirements.

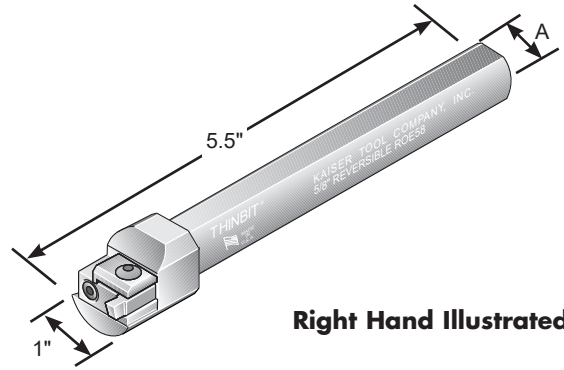

**Right Hand Illustrated**

**INSERT SELECTIONS**

**GROOVING**

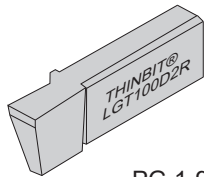

PG 1-9

**FACE GROOVING**

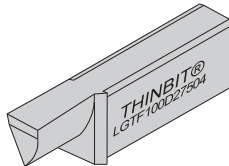

PG 2-9

**THREADING**

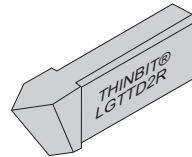

PG 4-9

**PARTING**

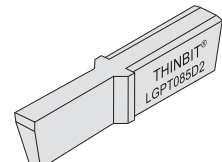

PG 5-3



Scan this code for additional information.

[www.thinbit.com/qr7-7](http://www.thinbit.com/qr7-7)

**ORDERING INSTRUCTIONS**

Select the **ORDER CODE** in the table below that represents your selection of shank dimensions.

**EXAMPLE:**

The **ORDER CODE** for a .625" round shank for inserts beginning with 'L' is:

**LROE58**

SPECIFICATIONS		ORDER CODE						
Shank Orientation	Shank Dimensions  'A'	Toolholder Package Includes Shank, Head, Clamp and Hardware  For Inserts Beginning With  'L'	Replacement Parts					Clamp Hardware
			Head Only Includes Clamp and Hardware For Inserts Beginning With  'L'	Head Screws	Head Wrenches	Shank	Clamp	
Right Hand or Left Hand  Use as right hand with right hand inserts; Use as left hand with left hand inserts; Use as either hand with centered inserts.	.500"	LROE12	LROEH	1 each: S5806 S2810	1 each: W1006 W1009	RROE12	Clamp C	Screw: S3808  Wrench: W1005
	.625"	LROE58				RROE58		
	.750"	LROE34				RROE34		
	1.000"	LROE01				RROE01		

**KAISER TOOL COMPANY, INC.**

**PRODUCT INFORMATION**

- Designed for boring bar positions on all machines.
- Toolholder reversible for left and right hand orientation.
- Shank sizes 1/2", 5/8", 3/4" and 1".
- All 1/2", 5/8" and 3/4" shanks are made from 1" shank.
- Modifications can be provided on any of our tooling. Please contact us with your application requirements.

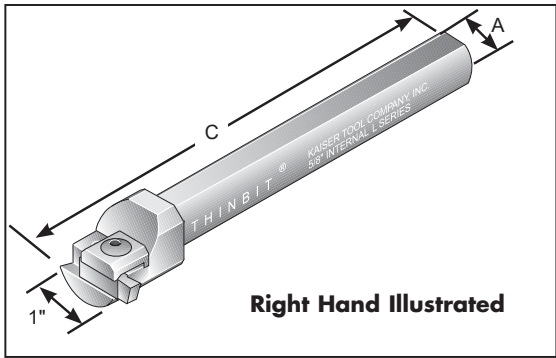

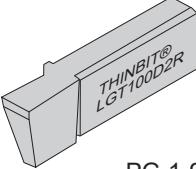
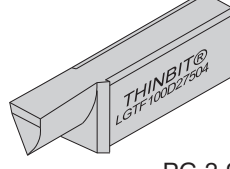
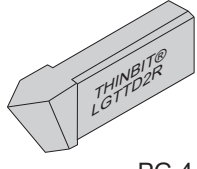
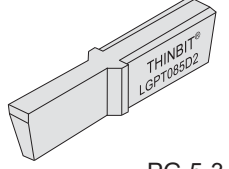
INSERT SELECTIONS	GROOVING	FACE GROOVING	THREADING	PARTING
	 PG 1-9	 PG 2-9	 PG 4-9	 PG 5-3



Scan this code for additional information.

[www.thinbit.com/qr7-8](http://www.thinbit.com/qr7-8)

**ORDERING INSTRUCTIONS**

Select the **ORDER CODE** in the table below that represents your selection of shank orientation and dimensions.

**EXAMPLE:**

The **ORDER CODE** for a .625" right hand shank for inserts beginning with 'L' is:

**LR5806**

SPECIFICATIONS				ORDER CODE				
Shank Orientation	Minimum Bore Diameter	Shank Dimensions		Toolholder Package Includes Shank, Clamp and Hardware  For Inserts Beginning With  'L'	Replacement Parts			
		'A'	'C'		Clamp	Screw	Wrench	Pin
Right Hand or Left Hand  Use as right hand with left hand inserts; Use as left hand with right hand inserts; Use as either hand with centered inserts.	1.250"	.500"	5.500"	LR1206	Clamp C	S3808	W1005	P0305
		.625"		LR5806				
		.750"		LR3406				
		1.000"	5.500"	LR0106				
			11.875"	LR0112				

**ROUND TOOLHOLDERS**

**KAISER TOOL COMPANY, INC.**

## PRODUCT INFORMATION

- Designed to reduce cycle time on those machines with adequate horsepower to handle the tool pressure.
- Pocket is filled with any selection of insert geometry and lengths. Proper edge to edge relation maintained with spacer blocks.
- Shank sizes 3/8", 1/2", 5/8", 3/4" and 1".
- Pocket sizes 1" and 2".
- Modifications can be provided on any of our tooling. Please contact us with your application requirements.

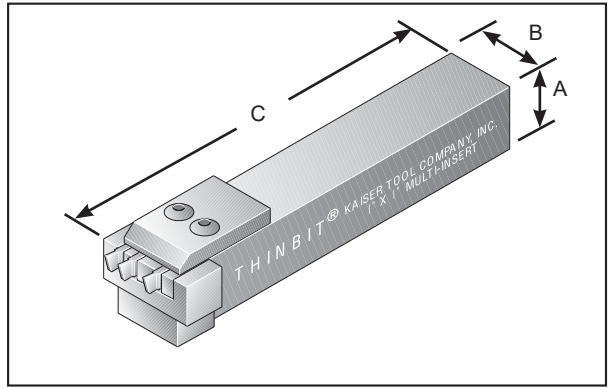

## INSERT SELECTION

Due to the potential complexity of configuring these toolholders, we recommend calling for assistance.  
See Page 8-7



Scan this code for additional information.

[www.thinbit.com/qr7-9](http://www.thinbit.com/qr7-9)

## ORDERING INSTRUCTIONS

Select the **ORDER CODE** in the table below that represents your selection of shank dimensions.

### EXAMPLE:

The **ORDER CODE** for a 1" pocket on a 1" square shank is:

**EM010101**

SPECIFICATIONS				ORDER CODE						
Pocket Size	Shank Dimensions			Toolholder Package Includes Shank, Pocket, Clamp and Hardware	Replacement Parts					
	'A'	'B'	'C'		Call For Inserts	Pocket Includes Hardware Call For Inserts	Pocket Hardware	Backplate	Shank	Clamp
1" Pocket	.375"	1.000"	4.840"	EM013801	HM0101	Screw: 2 each S1604 S3810	---	ESM0138	Clamp M	Screw: 2 each S3808
	.500"			EM011201				ESM0112		
	.625"			EM015801				ESM0158		
	.750"			EM013401				ESM0134		
	1.000"			EM010101				ESM0101		
2" Pocket	.375"	1.000"	4.840"	EM013802	HM0102	Wrench: 1 each: W1004 W1005	Backplate: BP0002  Screws: 4 each S5404	ESM0138	Clamp N	Wrench: W1005
	.500"			EM011202				ESM0112		
	.625"			EM015802				ESM0158		
	.750"			EM013402				ESM0134		
	1.000"			EM010102				ESM0101		

## KAISER TOOL COMPANY, INC.

**PRODUCT INFORMATION**

- Designed to reduce cycle time on those machines with adequate horsepower to handle the tool pressure.
- Pocket is filled with any selection of insert geometry and lengths. Proper edge to edge relation maintained with spacer blocks.
- Shank size 1".
- Pocket size 1".
- Modifications can be provided on any of our tooling. Please contact us with your application requirements.

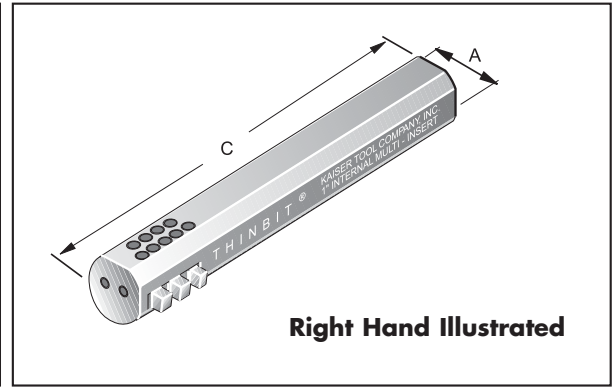

**INSERT SELECTION**

Due to the potential complexity of configuring these toolholders, we recommend calling for assistance.  
See Page 8-7



Scan this code for additional information.

[www.thinbit.com/qr7-10](http://www.thinbit.com/qr7-10)

**ORDERING INSTRUCTIONS**

Select the **ORDER CODE** in the table below that represents your selection of shank dimensions.

**EXAMPLE:**

The **ORDER CODE** for a 1" right hand shank, 5.5" long is:

**ROM0106**

SPECIFICATIONS				ORDER CODE				
Pocket Size & Shank Orientation	Minimum Bore Diameter	Shank Dimensions		Toolholder Package Includes Shank and Hardware	Replacement Parts			
		'A'	'C'		Call For Inserts	End Screws	Clamping Screws	Wrench
1" Pocket Right Hand	1.125" Varies depending on configuration	1.000"	5.500"	ROM0106	2 each: S1804	9 each: S1808	W1005	P0001
			11.875"	ROM0112				

**MULTI-INSERT TOOLHOLDERS**

**KAISER TOOL COMPANY, INC.**

**PRODUCT INFORMATION**

- Designed for making angled undercuts.
- Toolholder must be used with inserts that have radial relief.
- Groove widths less than .080" may require a special insert.
- Shank sizes 3/8", 1/2", 5/8", 3/4" and 1".
- Modifications can be provided on any of our tooling. Please contact us with your application requirements.

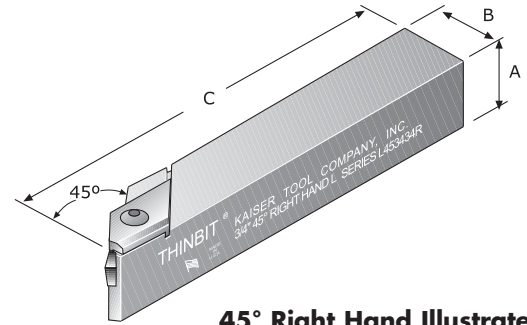

**45° Right Hand Illustrated**

**INSERT SELECTIONS**

**FACE GROOVING**

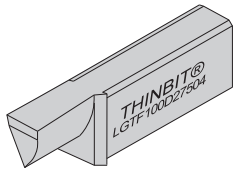

PG 2-9

Due to the potential complexity of configuring these toolholders, we recommend calling for assistance.



Scan this code for additional information

[www.thinbit.com/qr7-11](http://www.thinbit.com/qr7-11)

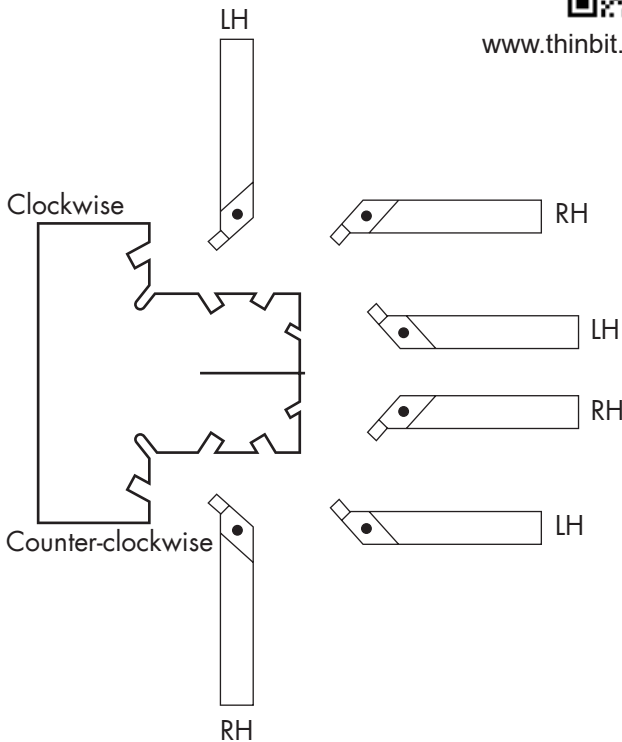

APPLICATION EXAMPLES  
 TOP VIEW, CUTTING EDGE UP

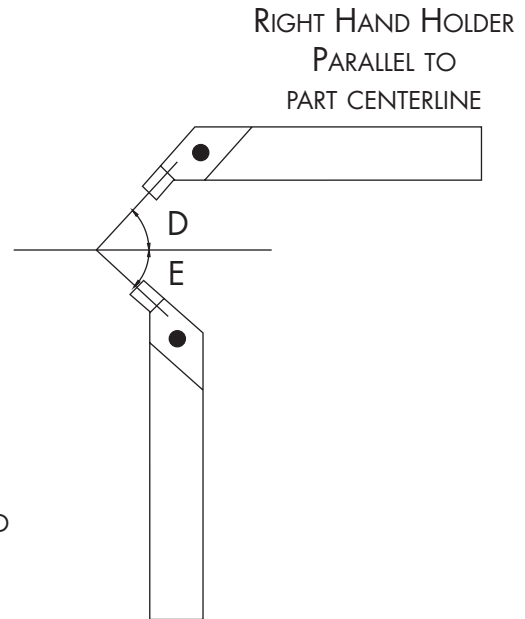

45° ILLUSTRATED

RIGHT HAND HOLDER  
 PERPENDICULAR TO  
 PART CENTERLINE

**KAISER TOOL COMPANY, INC.**

**ORDERING INSTRUCTIONS**

Select the **ORDER CODE** in the table below that represents your selection of shank orientation and dimensions.

**EXAMPLE:**

The **ORDER CODE** for a 45° holder with a .750" right hand shank is:

**L453434R**

SPECIFICATIONS (Page 7-11)						ORDER CODE				
Shank Angle		Shank Orientation	Shank Dimensions			Toolholder Package Includes Shank, Clamp and Hardware  For Inserts Beginning With  'L'	Replacement Parts			
'D' <small>Toolholder parallel to part centerline</small>	'E' <small>Toolholder perpendicular to part centerline</small>		'A'	'B'	'C'		Clamp	Screw	Wrench	Pin
45°	45°	Right Hand Use with left hand and centered inserts for counter-clockwise rotation	.375"	.750"	4.840"	L453438R	Clamp Q	S3808	W1005	* C0509
			.500"			L453412R				
			.625"			L453458R				
			.750"			L453434R				
			1.000"			L450101R				
		Left Hand Use with right hand and centered inserts for clockwise rotation	.375"	L453438L						
			.500"	L453412L						
			.625"	L453458L						
			.750"	L453434L						
			1.000"	L450101L						
60°	30°	Right Hand Use with left hand and centered inserts for counter-clockwise rotation	.375"	.750"	4.840"	L363438R	Clamp Y			
			.500"			L363412R				
			.625"			L363458R				
			.750"			L363434R				
			1.000"			L360101R				
		Left Hand Use with right hand and centered inserts for clockwise rotation	.375"	L363438L						
			.500"	L363412L						
			.625"	L363458L						
			.750"	L363434L						
			1.000"	L360101L						

**45° & 30°/60° TOOLHOLDERS**

\* Roll Pin sizes may have changed due to manufacturing updates. Toolholders will be shipped with the correct item. Replacement pin (C0509) will contain two items (P0204 & P0305) to accommodate either revision.

**KAISER TOOL COMPANY, INC.**



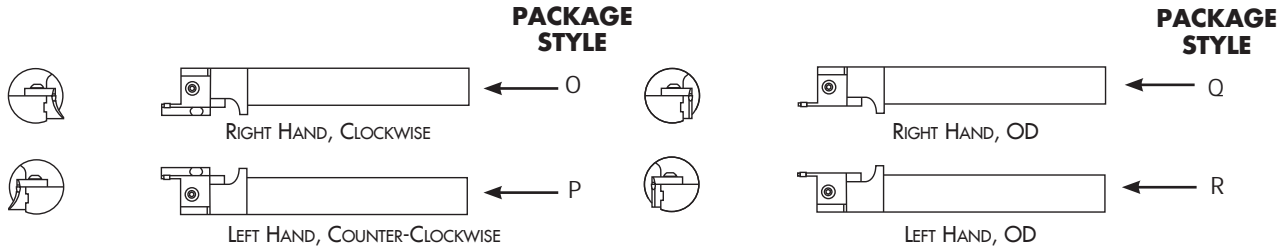

SPECIFICATIONS				ORDER CODE											
Insert Width	Depth of Cut	Package Style	Inserts Page 6-1 Use Inserts Beginning With	Toolholder Package Includes Shank, Head, Clamp and Hardware		Inserts Use Inserts Beginning With	Replacement Parts								
				3/4" Shank 3/4"Ø x 7"	1" Shank 1"Ø x 7"		Head	Head Hardware	Shank 34 = 3/4" 01 = 1" 20 = 20mm 25 = 25mm	Clamp	Clamp Hardware				
2mm (.078")	13mm (1/2")	O	'DGI2'	DGPO201334__	DGPO201301__	'DGI2'  (Page 6-1)	DGH32013__	Screw: 2 each S7552	DGS__ZR	DGC12013	Screw: S6552  Wrench: W4025				
		Q*		DGPQ201334	DGPQ201301		DGH12013		DGS__ZL	DGC22013					
		P		DGPP201334__	DGPP201301__		DGH42013__		DGS__ZR	DGC13013					
		R*		DGPR201334	DGPR201301		DGH22013		DGS__ZL	DGC23013					
3mm (.118")	13mm (1/2")	O	Use 'DGM13' for major diameter codes '02' & '25' 'DGI3' for all others	DGPO301334__	DGPO301301__	Use 'DGM13' for major diameter codes '02' & '25' 'DGI3' for all others  (Page 6-1)	DGH33013__		Screw: 2 each S7552	DGS__ZR		DGC13013	Screw: S6552  Wrench: W4025		
		Q*		DGPQ301334	DGPQ301301		DGH13013			DGS__ZL		DGC23013			
		P		DGPP301334__	DGPP301301__		DGH43013__			DGS__ZR		DGC14013			
		R*		DGPR301334	DGPR301301		DGH23013			DGS__ZL		DGC24013			
4mm (.157")	13mm (1/2")	O	Use 'DGM14' for major diameter codes '02' & '25' 'DGI4' for all others	DGPO401334__	DGPO401301__	Use 'DGM14' for major diameter codes '02' & '25' 'DGI4' for all others  (Page 6-1)	DGH34013__			Screw: 2 each S7552		DGS__ZR		DGC14013	Screw: S6552  Wrench: W4025
		Q*		DGPQ401334	DGPQ401301		DGH14013					DGS__ZL		DGC24013	
		P		DGPP401334__	DGPP401301__		DGH44013__					DGS__ZR		DGC14020	
		R*		DGPR401334	DGPR401301		DGH24013					DGS__ZL		DGC24020	
	20mm (3/4")	O		DGPO402034__	DGPO402001__		DGH34020__	DGS__ZR			DGC14020				
		Q*		DGPQ402034	DGPQ402001		DGH14020	DGS__ZL			DGC24020				
5mm (.197")	13mm (1/2")	O	'DGI5'	DGPO501334__	DGPO501301__	(Page 6-1)	DGH35013__	Wrench: W4025			DGS__ZR	DGC15013		Wrench: W4025	
		Q*		DGPQ501334	DGPQ501301		DGH15013				DGS__ZL	DGC25013			
		P		DGPP501334__	DGPP501301__		DGH45013__		DGS__ZR		DGC15025				
		R*		DGPR501334	DGPR501301		DGH25013		DGS__ZL		DGC25025				
	25mm (1")	O		DGPO502534__	DGPO502501__		DGH35025__		DGS__ZR		DGC15025				
		Q*		DGPQ502534	DGPQ502501		DGH15025		DGS__ZL		DGC25025				
		P		DGPP502534__	DGPP502501__		DGH45025__		DGS__ZR	DGC16013					
		R*		DGPR502534	DGPR502501		DGH25025		DGS__ZL	DGC26013					
6mm (.236")	13mm (1/2")	O	'DGI6'	DGPO601334__	DGPO601301__	(Page 6-1)	DGH36013__		Wrench: W4025	DGS__ZR	DGC16013	Wrench: W4025			
		Q*		DGPQ601334	DGPQ601301		DGH16013			DGS__ZL	DGC26013				
		P		DGPP601334__	DGPP601301__		DGH46013__			DGS__ZR	DGC16025				
		R*		DGPR601334	DGPR601301		DGH26013			DGS__ZL	DGC26025				
	25mm (1")	O		DGPO602534__	DGPO602501__		DGH36025__	DGS__ZR		DGC16025					
		Q*		DGPQ602534	DGPQ602501		DGH16025	DGS__ZL		DGC26025					
		P		DGPP602534__	DGPP602501__		DGH46025__	DGS__ZR		DGC16025					
		R*		DGPR602534	DGPR602501		DGH26025	DGS__ZL		DGC26025					

\* Codes not required on Q and R packages

Major Diameter Range	Insert Width	Code	Insert Style	Major Diameter Range	Insert Width	Code	Insert Style	
.787"-.885" (20-22.5mm)	2mm	02	DGI	1.377"-1.574" (35-40mm)	2mm	50	DGI	
	3 & 4mm	02	DGMI		3, 4, 5 & 6mm	34	DGI	
.885"-.984" (22.5-25mm)	2mm	25	DGI		1.574"-1.968" (40-50mm)	All	45	DGI
	3 & 4mm	25	DGMI		1.968"-2.362" (50-60mm)		56	DGI
.984"-1.082" (25-27.5mm)	2mm	57	DGI		2.362"-2.952" (60-75mm)		67	DGI
	3, 4, 5 & 6mm	23	DGI		2.952"-3.937" (75-100mm)		71	DGI
1.082"-1.181" (27.5-30mm)	2mm	70	DGI		3.937"-5.905" (100-150mm)		11	DGI
	3, 4, 5 & 6mm	23	DGI		5.905"-11.811" (150-300mm)		13	DGI
1.181"-1.377" (30-35mm)	2mm	05	DGI		11.811" - ∞ (300mm-∞)	30	DGI	
	3, 4, 5 & 6mm	34	DGI					

Note:  
As long as first plunge is made within major diameter range and each following plunge overlaps, groove width can be increased toward or away from center of part.

# DEEPGROOVE<sup>®</sup> SQUARE SHANKS WITH INTERNAL FACE GROOVING HEADS

U.S. PATENT NO. 5,638,728

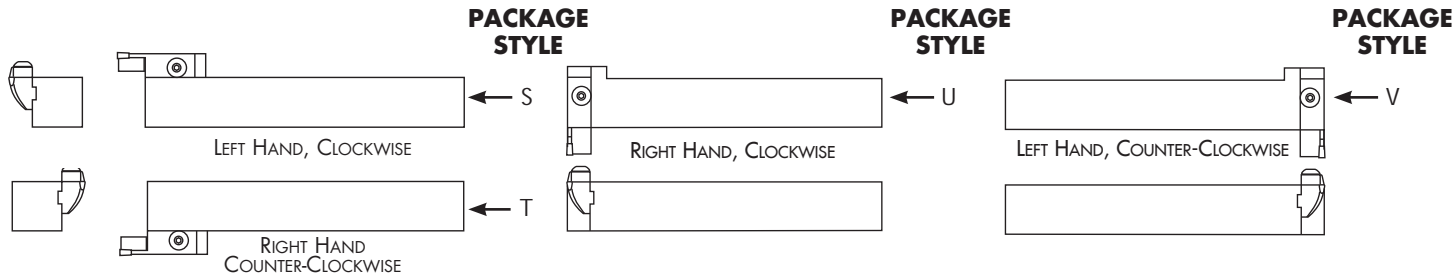

SPECIFICATIONS			ORDER CODE								
Insert Width	Depth of Cut	Package Style See Above	Toolholder Package Includes Shank, Head, Clamp and Hardware			Inserts Use Inserts Beginning With	Replacement Parts				
			3/4" Shank 3/4"x3/4"x5"	1" Shank 1"x1"x5"	Metric Shanks 16 = 16x16x125mm 20 = 20x1"x125mm 25 = 25x1"x125mm		Head	Head Hardware	Shank 34 = 3/4" 01 = 1" 16 = 16mm 20 = 20mm 25 = 25mm	Clamp	Clamp Hardware
2mm (.078")	13mm (1/2")	S	DGPS201334__	DGPS201301__	DGPS2013__	'DGI2'  (Page 6-1)	DGH52013__  DGH62013__		DGS__XL	DGC52013	
		U	DGPU201334__	DGPU201301__	DGPU2013__				DGS__YR		
		T	DGPT201334__	DGPT201301__	DGPT2013__				DGS__XR	DGC62013	
		V	DGPV201334__	DGPV201301__	DGPV2013__				DGS__YL		
3mm (.118")	13mm (1/2")	S	DGPS301334__	DGPS301301__	DGPS3013__	'DGI3'  (Page 6-1)	DGH53013__  DGH63013__		DGS__XL	DGC53013	
		U	DGPU301334__	DGPU301301__	DGPU3013__				DGS__YR		
		T	DGPT301334__	DGPT301301__	DGPT3013__				DGS__XR	DGC63013	
		V	DGPV301334__	DGPV301301__	DGPV3013__				DGS__YL		
4mm (.157")	13mm (1/2")	S	DGPS401334__	DGPS401301__	DGPS4013__	'DGI4'  (Page 6-1)	DGH54013__  DGH64013__	Screw: 2 each S7552	DGS__XL	DGC54013	Screw: S6552
		U	DGPU401334__	DGPU401301__	DGPU4013__				DGS__YR		
		T	DGPT401334__	DGPT401301__	DGPT4013__				DGS__XR	DGC64013	
		V	DGPV401334__	DGPV401301__	DGPV4013__				DGS__YL		
	20mm (3/4")	S	DGPS402034__	DGPS402001__	DGPS4020__		DGH54020__  DGH64020__		DGS__XL	DGC54020	
		U	DGPU402034__	DGPU402001__	DGPU4020__				DGS__YR		
		T	DGPT402034__	DGPT402001__	DGPT4020__				DGS__XR	DGC64020	
		V	DGPV402034__	DGPV402001__	DGPV4020__				DGS__YL		
5mm (.197")	13mm (1/2")	S	DGPS501334__	DGPS501301__	DGPS5013__	'DGI5'  (Page 6-1)	DGH55013__  DGH65013__	Wrench: W4025	DGS__XL	DGC55013	Wrench: W4025
		U	DGPU501334__	DGPU501301__	DGPU5013__				DGS__YR		
		T	DGPT501334__	DGPT501301__	DGPT5013__				DGS__XR	DGC65013	
		V	DGPV501334__	DGPV501301__	DGPV5013__				DGS__YL		
	25mm (1")	S	DGPS502534__	DGPS502501__	DGPS5025__		DGH55025__  DGH65025__		DGS__XL	DGC55025	
		U	DGPU502534__	DGPU502501__	DGPU5025__				DGS__YR		
		T	DGPT502534__	DGPT502501__	DGPT5025__				DGS__XR	DGC65025	
		V	DGPV502534__	DGPV502501__	DGPV5025__				DGS__YL		
6mm (.236")	13mm (1/2")	S	DGPS601334__	DGPS601301__	DGPS6013__	'DGI6'  (Page 6-1)	DGH56013__  DGH66013__		DGS__XL	DGC56013	
		U	DGPU601334__	DGPU601301__	DGPU6013__				DGS__YR		
		T	DGPT601334__	DGPT601301__	DGPT6013__				DGS__XR	DGC66013	
		V	DGPV601334__	DGPV601301__	DGPV6013__				DGS__YL		
	25mm (1")	S	DGPS602534__	DGPS602501__	DGPS6025__		DGH56025__  DGH66025__		DGS__XL	DGC56025	
		U	DGPU602534__	DGPU602501__	DGPU6025__				DGS__YR		
		T	DGPT602534__	DGPT602501__	DGPT6025__				DGS__XR	DGC66025	
		V	DGPV602534__	DGPV602501__	DGPV6025__				DGS__YL		



Major Diameter Range	Code
1.574"-1.968" (40-50mm)	45
1.968"-2.362" (50-60mm)	56
2.362"-2.952" (60-75mm)	67
2.952"-3.937" (75-100mm)	71
3.937"-5.905" (100-150mm)	11
5.905"-11.811" (150-300mm)	13
11.811"-∞ (300mm-∞)	30

**Note:**  
As long as first plunge is made within major diameter range and each following plunge overlaps, groove width can be increased toward or away from center of part.

DEEPGROOVE<sup>®</sup>  
ALTERNATE PKGS

**If you require a modification other than those detailed on the following pages, please call or submit your application print to our sales office.**

<u>PAGE</u>	<u>MODIFICATION TYPE</u>
8-2	Face grooving
8-3	Definition of modifications
8-4	Modification specification sheet
8-5	Custom threads
8-6	Solid carbide custom blanks
8-7	Form tools

**We are an industry leader at making custom tooling with competitive prices and fast delivery.**

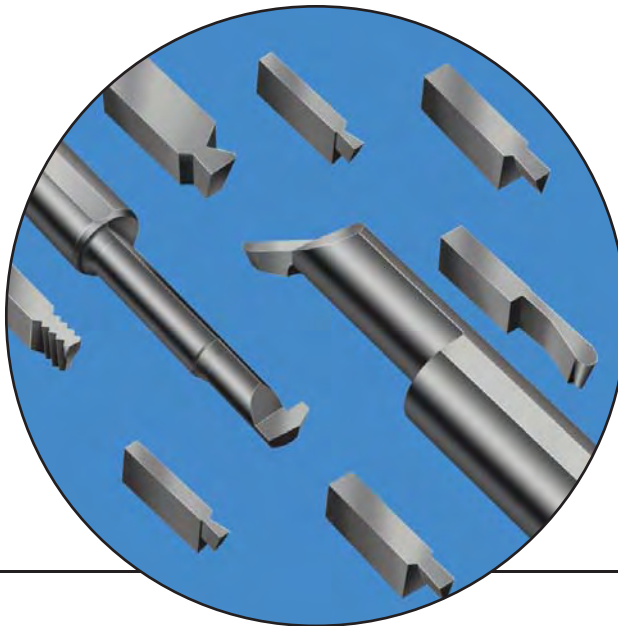

**Our staff of sales associates and applications engineers process your quotes within 48 hours!**

### QUOTATION TO ORDER PROCESS

- Submit an application print or catalog sheet detailing your requirements. Include company name, contact name, email, telephone and fax numbers. Submissions can be faxed to (260) 482-1881, or emailed to: [quotes@thinbit.com](mailto:quotes@thinbit.com).
- A quote will be returned within 48 hours which will include CAD drawings, price, delivery and payment terms.
- Review the quote information and CAD drawings. Fill in the 'Quote Summary Sheet' with item quantities and approval signatures.
- Fax or email the 'Quote Summary Sheet' to our sales office.
- The order will be confirmed via fax or email. The confirmation will summarize order and include delivery date.

Scan this code for additional information



[www.thinbit.com/qr8-1](http://www.thinbit.com/qr8-1)

### KAISER TOOL COMPANY, INC.

Phone: 888-THINBIT (888-844-6248) or (260) 484-3620 • Fax: 888-THINFAX (888-844-6329) or (260) 482-1881  
www.thinbit.com • General E-mail: [thinbit@kaisertool.com](mailto:thinbit@kaisertool.com) • Orders: [orders@thinbit.com](mailto:orders@thinbit.com) • Quotes: [quotes@thinbit.com](mailto:quotes@thinbit.com)

### PROVIDE THESE TOOLING SPECIFICATIONS

FACE GROOVE TYPE:

- Flat Face       Shoulder Face  
 Internal       Angled

SPINDLE ROTATION: (Looking at spindle face)

- Clockwise       Counter-Clockwise

WIDTH ('A'): \_\_\_\_\_

(.004" minimum suggested)

DEPTH OF CUT ('B'): \_\_\_\_\_

(as required)

MAJOR DIAMETER ('C'): \_\_\_\_\_

(.200" minimum suggested)

DEPTH INTO BORE ('D'): \_\_\_\_\_

(as required)

ANGLE ('E'): \_\_\_\_\_

(as required)

MATERIAL BEING MACHINED: \_\_\_\_\_

COATING OPTIONS:

- TiN       TiCN  
 TiAlN       Diamond

TOOLHOLDER OPTIONS:

- Square       Straight       Right Hand      Shank  
 Round       90°       Left Hand      Size: \_\_\_\_\_

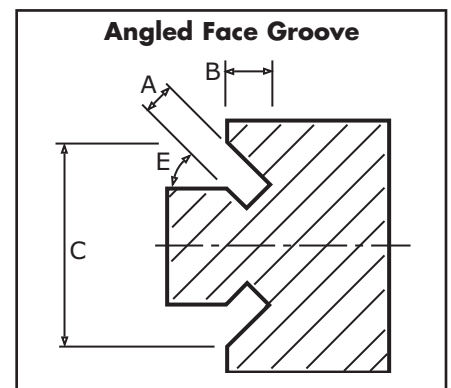
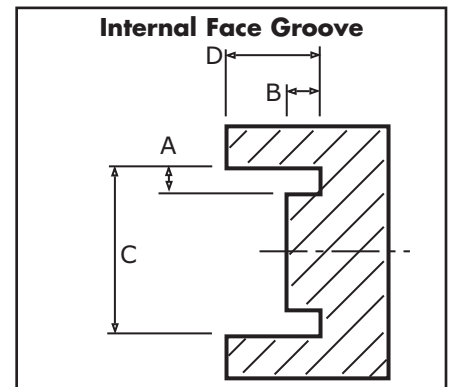
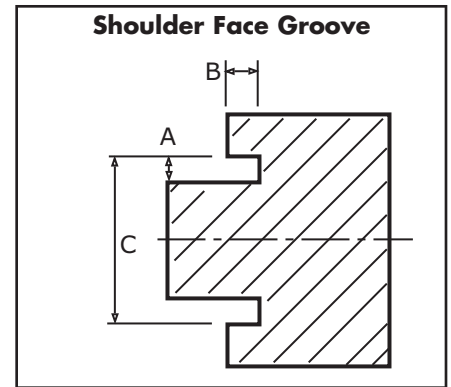
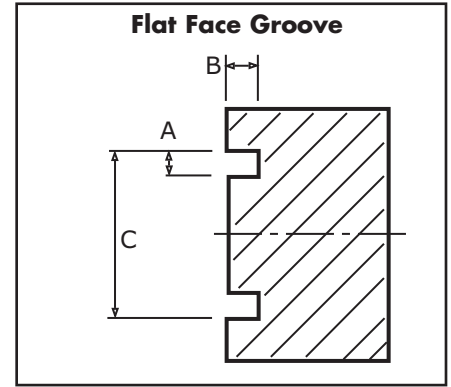

Submitting this form will generate a quote within 48 hours which will include price, delivery and CAD drawing(s) for your review and approval. If possible, please include an application print or sketch.

Return quote to:

Name: \_\_\_\_\_

Company: \_\_\_\_\_





Address: \_\_\_\_\_

Phone: (\_\_\_\_) - \_\_\_\_\_ - \_\_\_\_\_

Fax: (\_\_\_\_) - \_\_\_\_\_ - \_\_\_\_\_

Email Address: \_\_\_\_\_

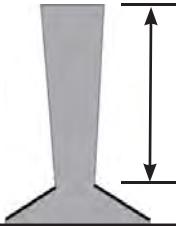
### KAISER TOOL COMPANY, INC.

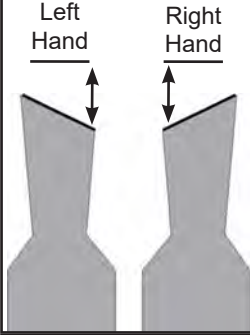
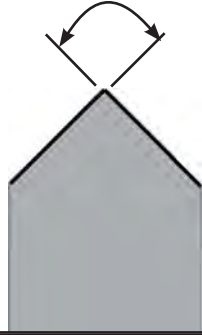
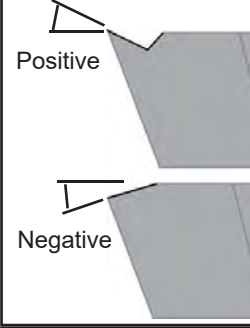
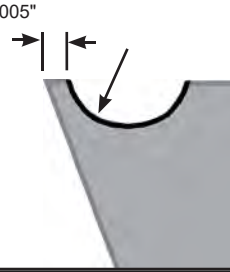
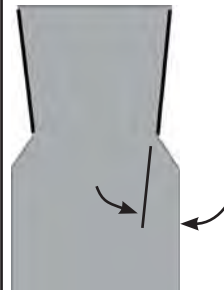
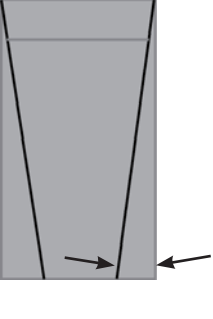
 <p><b>SIZING</b> Looking at the top of the insert, sizing is the width of the cutting edge.</p>	 <p><b>RADIUS</b> Looking at the top of the insert, the radii are the rounded corners of the cutting edge. A full radius means each radius is one half the width of the insert.</p>
 <p><b>DEPTH OF CUT</b> Looking at the top of the insert, depth of cut is the depth the insert will cut into part before edge(s) drag.</p>	 <p><b>CHAMFER</b> Looking at the top of the insert, chamfer is a secondary cutting edge. Standard angle is 45°.</p>
 <p><b>LEAD ANGLE</b> Looking at the top of the insert, lead angle is the angle along the cutting edge of the insert.</p> <p>Left Hand      Right Hand</p>	 <p><b>INCLUDED ANGLE</b> Looking at the top of the insert, the included angle is the angle between the cutting edges.</p>
 <p><b>TOP RAKE</b> Looking at the side of the insert, top rake is the angle between the top of the insert and the cutting edge.</p> <p>Positive Negative</p>	 <p><b>CHIPBREAKER</b> Looking at the side of the insert, a chipbreaker is a 1/32" radius ground .005" back from the cutting edge.</p>
 <p><b>BACK CLEARANCE</b> Looking at the top of the insert, back clearance is the angle behind the cutting edge.</p>	 <p><b>SIDE CLEARANCE</b> Looking at the front of the insert, side clearance is the angle from the top of the insert to the bottom of the insert.</p>

### KAISER TOOL COMPANY, INC.

BASE TOOL: \_\_\_\_\_

MATERIAL BEING MACHINED: \_\_\_\_\_

COATING OPTIONS: (Select 1 only)

- TiN       TiCN  
 TiAlN    Diamond

TOOLHOLDER OPTIONS: Size \_\_\_\_\_

- Square     Straight  Right Hand  
 Round      90°      Left Hand

SPINDLE ROTATION (Looking at spindle face)

- Clockwise    Counter-Clockwise

**SKETCH AREA**

Submitting this form will generate a quote within 48 hours which will include price, delivery and CAD drawing(s) for your review and approval. If possible, please include an application print or sketch.

Return quote to: \_\_\_\_\_

Name: \_\_\_\_\_

Company: \_\_\_\_\_

Address: \_\_\_\_\_

Phone: (\_\_\_\_) - \_\_\_\_ - \_\_\_\_\_

Fax: (\_\_\_\_) - \_\_\_\_ - \_\_\_\_\_

Email Address: \_\_\_\_\_

	Left Hand Side Geometry	Right Hand Side Geometry
	_____ Insert Width in .xxx"  _____ Tolerance in +.xxx"/-.xxx" (± .001" standard)	
	<input type="checkbox"/> Full Radius	
	_____ Corner Radius in .xxx" _____ Tolerance in +.xxx"/-.xxx" (± .002" standard)	_____ Corner Radius in .xxx" _____ Tolerance in +.xxx"/-.xxx" (± .002" standard)
	_____ Total Depth of Cut in .xxx"	_____ Total Depth of Cut in .xxx"
	_____ Chamfer Angle in x°  _____ Total Depth of Chamfer required in .xxx"  _____ Tolerance in +.xxx"/-.xxx" (± .001" standard)	_____ Chamfer Angle in x°  _____ Total Depth of Chamfer required in .xxx"  _____ Tolerance in +.xxx"/-.xxx" (± .001" standard)
	_____ Lead Angle in x°  _____ Tolerance in +x°/-x° (± .5° standard)	_____ Lead Angle in x°  _____ Tolerance in +x°/-x° (± .5° standard)
	_____ Included Angle in x°  _____ Tolerance in +x°/-x° (± .5° standard)	
	_____ Top Rake Angle in x° <input type="checkbox"/> Positive <input type="checkbox"/> Negative  _____ Tolerance in +x°/-x° (± .5° standard)	
	<input type="checkbox"/> 1/32" Radius Chipbreaker with .005" land	
	_____ Back Clearance in x°  _____ Tolerance in +x°/-x° (± .5° standard)	_____ Back Clearance in x°  _____ Tolerance in +x°/-x° (± .5° standard)
	_____ Side Clearance in x°  _____ Tolerance in +x°/-x° (± .5° standard)	_____ Side Clearance in x°  _____ Tolerance in +x°/-x° (± .5° standard)

### KAISER TOOL COMPANY, INC.



### PROVIDE THESE TOOLING SPECIFICATIONS

THREAD TYPE:

EXTERNAL

INTERNAL BORE DIAMETER: \_\_\_\_\_

REACH INTO BORE: \_\_\_\_\_

ORIENTATION:

RIGHT HAND

LEFT HAND

FEED DIRECTION:

Toward Spindle

Away from Spindle

ANSI THREAD FORM: \_\_\_\_\_

THREAD FORM: \_\_\_\_\_

(Acme, Buttress, Square, etc.)

THREADS PER INCH: \_\_\_\_\_

NUMBER OF STARTS: \_\_\_\_\_

MAJOR DIAMETER: \_\_\_\_\_

(Largest diameter of thread)

MINOR DIAMETER: \_\_\_\_\_

(Smallest diameter of thread)

MATERIAL BEING MACHINED: \_\_\_\_\_

COATING OPTIONS:

TIN

TiCN

TiAlN

DIAMOND

TOOLHOLDER OPTIONS:

Square

Straight

Right Hand

Round

90°

Left Hand

SHANK SIZE: \_\_\_\_\_

### SKETCH AREA

Submitting this form will generate a quote within 48 hours which will include price, delivery and CAD drawing(s) for your review and approval. If possible, please include an application print or sketch.

Return quote to:

Name: \_\_\_\_\_

Company: \_\_\_\_\_

Address: \_\_\_\_\_

Phone: (\_\_\_\_)-\_\_\_\_-\_\_\_\_\_

Fax: (\_\_\_\_)-\_\_\_\_-\_\_\_\_\_

Email Address: \_\_\_\_\_

### KAISER TOOL COMPANY, INC.

## PROVIDE THESE TOOLING SPECIFICATIONS

### TOOL TYPE:

- Grooving       Face Grooving  
 Boring         Threading

### ORIENTATION:

- Right Hand     Left Hand

WIDTH ('A'): \_\_\_\_\_  
 (.004" minimum)

SHANK DIAMETER ('B'): \_\_\_\_\_  
 (1/8", 3/16", 1/4", 5/16", 3/8", 1/2")

### MINIMUM

BORE DIAMETER ('C'): \_\_\_\_\_  
 (.073" minimum suggested)

OVERALL LENGTH ('D'): \_\_\_\_\_  
 (.875" minimum, 4" maximum suggested;  
 stock lengths may be substituted)

REACH ('E'): \_\_\_\_\_  
 (.250" minimum, 4 times 'B' maximum suggested)

PROJECTION ('F'): \_\_\_\_\_  
 (3 times 'A' maximum suggested;  
 for threading tool, specify threads per inch)

MATERIAL BEING MACHINED: \_\_\_\_\_

### COATING OPTIONS:

- TiN                       TiCN  
 TiAlN                 DIAMOND

Submitting this form will generate a quote within 48 hours which will include price, delivery and CAD drawing(s) for your review and approval. If possible, please include an application print or sketch.

Return quote to:

Name: \_\_\_\_\_

Company: \_\_\_\_\_

Address: \_\_\_\_\_

\_\_\_\_\_

Phone: (\_\_\_\_) - \_\_\_\_ - \_\_\_\_

Fax: (\_\_\_\_) - \_\_\_\_ - \_\_\_\_

Email Address: \_\_\_\_\_

### Grooving Tool Geometry

Right hand shown. See Page 1-4 for standard cutting geometry.

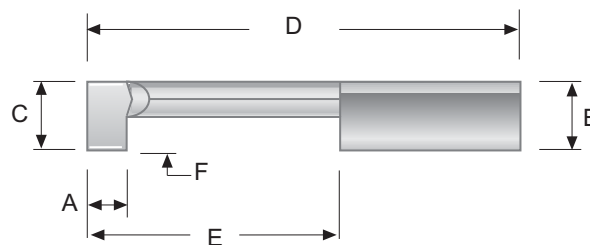

### Face Grooving Tool Geometry

Clockwise shown. See Page 2-4 for standard cutting geometry.

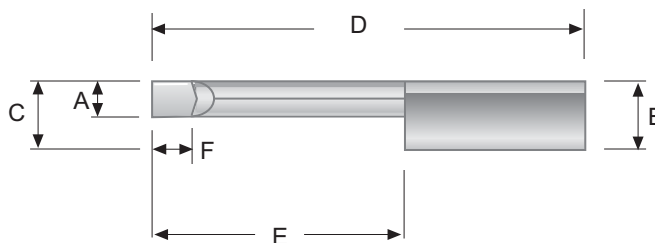

### Boring Tool Geometry

Right hand shown. See Page 3-4 for standard cutting geometry.

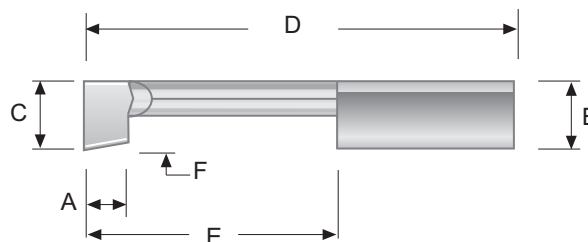

### Threading Tool Geometry

Right hand shown. See Page 4-4 & 4-6 for standard cutting geometry.

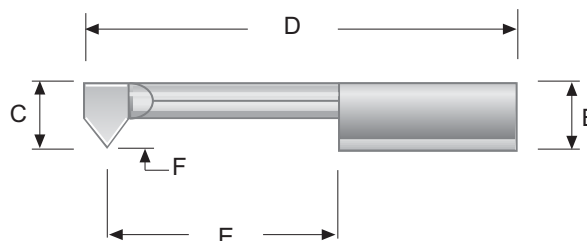

CUSTOM BLANKS  
MODIFICATIONS

## KAISER TOOL COMPANY, INC.

# THINBIT®



**FORM-A-GROOVE®** tools can consist of combinations of simple grooves or more complex combinations of grooves, arcs, angles, convex and concave radii, as well as special thread forms.

**FORM-A-GROOVE®** tools can simplify programming, increase production and free tool locations for other tools.

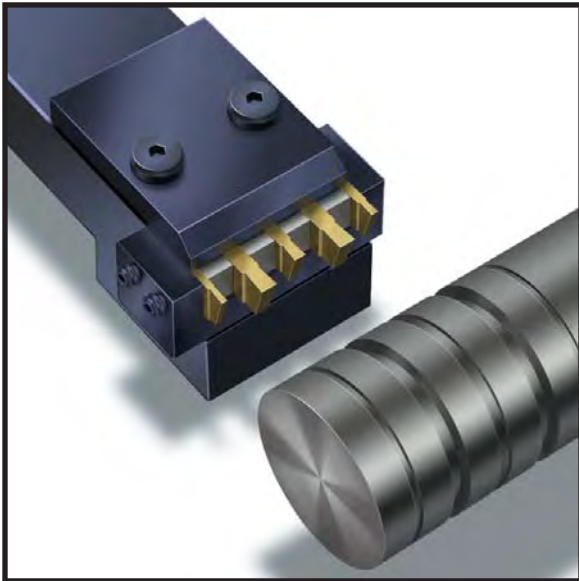

External and Face applications

- Up to 2" wide
- Made from stacking individual inserts or from a solid block of carbide

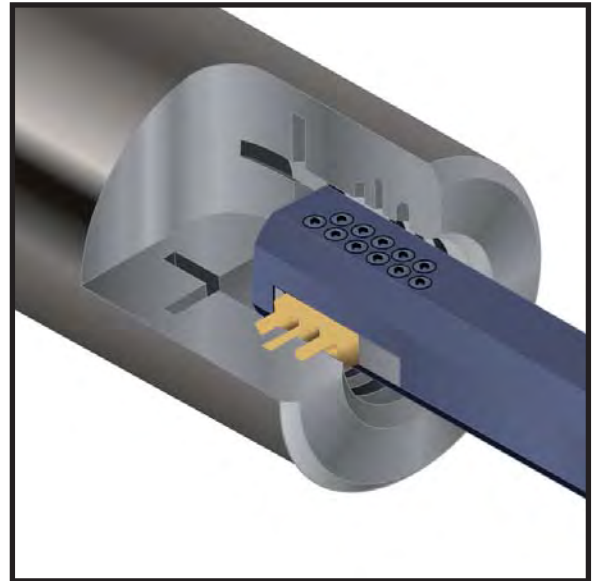

Internal applications

- Up to 1" wide
- Starting at .125" minimum bore

## QUOTATION TO ORDER PROCESS

- |  |   |
|--|---|
| <ul style="list-style-type: none"><li>• Submit an application print detailing your requirements. Include company name, contact name, email, telephone and fax numbers. If possible, please include an application print or sketch. Submissions can be faxed to (260) 482-1881, or emailed to: <a href="mailto:quotes@thinbit.com">quotes@thinbit.com</a>.</li><li>• A quote will be returned within 48 hours which will include CAD drawings, price, delivery and payment terms.</li></ul> | <ul style="list-style-type: none"><li>• Review the quote information and CAD drawings. Fill in the 'Quote Summary Sheet' with item quantities and approval signatures.</li><li>• Fax or Email the 'Quote Summary Sheet' to our sales office.</li><li>• The order will be confirmed via fax or email. The confirmation will summarize order and include delivery date.</li></ul> |
|--|---|



[www.thinbit.com/qr8-7](http://www.thinbit.com/qr8-7)

Scan this code  
for additional  
information

**If you require a modification other than those detailed on this page, please call or submit your application print to our sales office.**

**KAISER TOOL COMPANY, INC.**

Phone: 888-THINBIT (888-844-6248) or (260) 484-3620 • Fax: 888-THINFAX (888-844-6329) or (260) 482-1881  
www.thinbit.com • General E-mail: [thinbit@kaisertool.com](mailto:thinbit@kaisertool.com) • Orders: [orders@thinbit.com](mailto:orders@thinbit.com) • Quotes: [quotes@thinbit.com](mailto:quotes@thinbit.com)

	<b>GENERAL TECHNICAL INFORMATION</b>	
	PAGE 9-2	PAGE OMITTED
	PAGE 9-3	EXTERNAL APPLICATION REFERENCE
	PAGE 9-4	INTERNAL APPLICATION REFERENCE
	PAGE 9-5	INSERT GRADE INFORMATION
	PAGE 9-6	INSERT COATING INFORMATION
	PAGE 9-7	TROUBLESHOOTING INFORMATION
	PAGE 9-8	GENERAL TOOLHOLDER INFORMATION

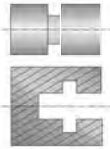
	<b>GROOVING - CATALOG SECTION 1</b>	
	PAGE 9-9	GEOMETRY AND SET-UP INFORMATION
	PAGE 9-10	SPEEDS AND FEEDS

	<b>FACE GROOVING - CATALOG SECTION 2</b>	
	PAGE 9-11	GEOMETRY AND SET-UP INFORMATION
	PAGE 9-12	SPEEDS AND FEEDS

	<b>BORING &amp; TURNING - CATALOG SECTION 3</b>	
	PAGE 9-13	GEOMETRY AND SET-UP INFORMATION
	PAGE 9-14	SPEEDS AND FEEDS FOR MBE, MBF AND MBG SERIES BORING BARS
	PAGE 9-15	SPEEDS AND FEEDS FOR MBZ, MBA, MBB AND MBC SERIES BORING BARS AND MICROBIT <sup>®</sup> SOLID CARBIDE BORING TOOLS
	PAGE 9-16	SPEEDS AND FEEDS FOR MBA, MBB AND MBC PCD AND CBN TIPPED INSERTS

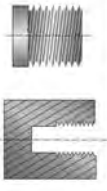
	<b>THREADING - CATALOG SECTION 4</b>	
	PAGE 9-17	GEOMETRY AND SET-UP INFORMATION
	PAGE 9-18	SPEEDS AND FEEDS

	<b>PARTING - CATALOG SECTION 5</b>	
	PAGE 9-19	GEOMETRY AND SET-UP INFORMATION
	PAGE 9-20	SPEEDS AND FEEDS

**HOURS:**

OUR BUSINESS HOURS ARE **7:30AM** TO **5:00PM** EASTERN STANDARD TIME.  
 PROCESSING FOR SAME DAY SHIPMENT STOPS AT **3:00PM** EASTERN STANDARD TIME.

**LOT NUMBERS:**

MOST PRODUCTS HAVE A 6 DIGIT LOT NUMBER LASER ENGRAVED ALONG WITH THE PART NUMBER.  
 THIS NUMBER MAY REQUIRE 10X MAGNIFICATION TO READ.

**NOTE:** REGISTERED PATENTS AND TRADEMARKS LICENSED TO KAISER TOOL COMPANY, INC. ARE  
 LOCATED ON OUR WEBSITE AT: [HTTP://WWW.THINBIT.COM/ABOUT/TRADE\\_NAMES.HTML](http://www.thinbit.com/about/trade_names.html)

**KAISER TOOL COMPANY, INC.**

Phone: 888-THINBIT (888-844-6248) or (260) 484-3620 • Fax: 888-THINFAX (888-844-6329) or (260) 482-1881  
[www.thinbit.com](http://www.thinbit.com) • General E-mail: [thinbit@kaisertool.com](mailto:thinbit@kaisertool.com) • Orders: [orders@thinbit.com](mailto:orders@thinbit.com) • Quotes: [quotes@thinbit.com](mailto:quotes@thinbit.com)

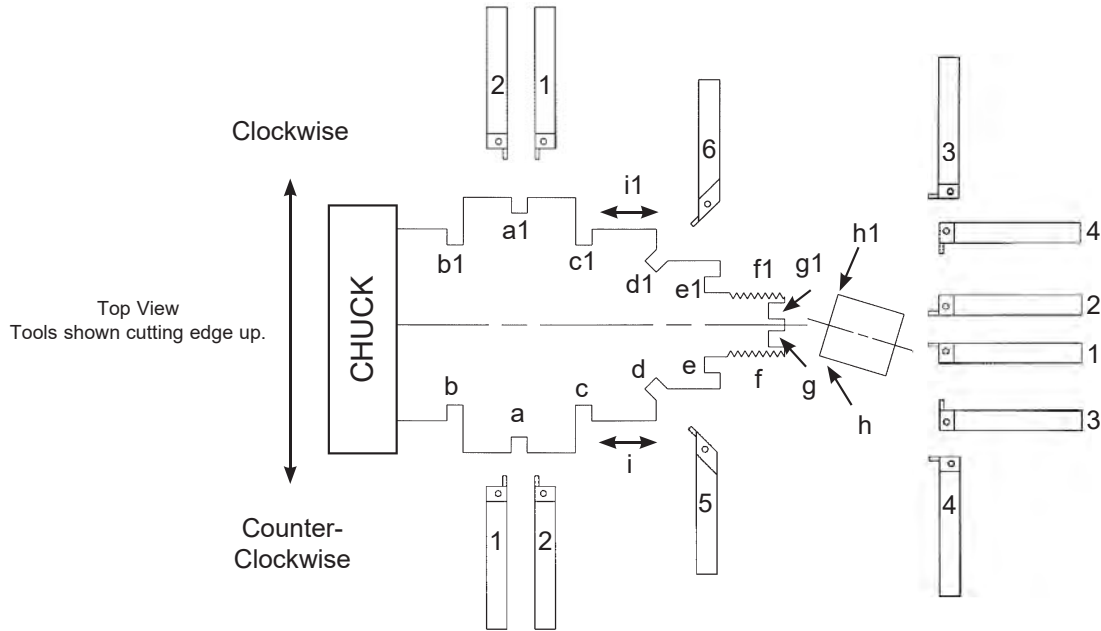

External Application Reference						
Description	Specification	Operation	Insert Orientation	Insert Page	Toolholder Compatibility	Toolholder Page
OD Groove Reference: a,a1	.004" - .150" insert widths in .001" increments; Depths of cut 2.5 to 3 times width; For grooving, turning and generating profiles; Carbide and High Speed Steel.	a	Right Hand	1-10	2,3	7-1
		a1	Left Hand	1-10	1,4	7-1
	2,3,4,5 & 6mm insert widths; Depths of cut .5" to 1".	a	---	6-2	2,3	1-11
		a1	---	6-2	1,4	1-11
OD Groove at a shoulder Reference: b,b1,c,c1	.004" - .150" insert widths in .001" increments; Depths of cut 2.5 to 3 times width; For grooving, turning and generating profiles; Carbide and High Speed Steel.	b & c1	Left Hand	1-10	1,4	7-1
		b1 & c	Right Hand	1-10	2,3	7-1
	2,3,4,5 & 6mm insert widths; Depths of cut .5" to 1".	b & c1	---	6-2	1,4	1-11
		b1 & c	---	6-2	2,3	1-11
30°/45°/60° Undercut Reference: d,d1	.004" - .150" insert widths in .001" increments; Depths of cut 2.5 to 3 times width; .300", .750", 1.250" & 3" major diameters.	d	Counter-Clockwise	2-10	5	7-11
		d1	Clockwise	2-10	6	7-11
Face Groove Reference: e,e1,g,g1	.004" - .150" insert widths in .001" increments; Depths of cut 2.5 to 3 times width; For grooving, turning and generating profiles; Carbide and High Speed Steel.	e & g	Counter-Clockwise	2-10	1,4	7-1
		e1 & g1	Clockwise	2-10	2,3	7-1
	2,3,4,5 & 6mm insert widths; Depths of cut .5" to 1".	e & g	---	6-2	1,4	2-11
		e1 & g1	---	6-2	2,3	2-11
Threading Reference: f,f1	8 Threads Per Inch and greater Carbide and High Speed Steel.	f	Right Hand	4-10	2,3	7-1
		f1	Left Hand	4-10	1,4	7-1
	Acme threading 4 Threads Per Inch and greater Carbide and High Speed Steel.	f & f1	Right Hand	4-12	2,3	7-1
Parting Reference: h,h1	.025", .045", .062", .085" & .115" insert widths; Depths of cut .200" and .500"; Carbide and High Speed Steel.	h	---	5-4	2,3	7-1
		h1	---	5-4	1,4	7-1
Turning Reference: i,i1	TD and TP style inserts.	i	---	3-16,3-18	2,3	3-20
		i1	---	3-16,3-18	1,4	3-20

### KAISER TOOL COMPANY, INC.



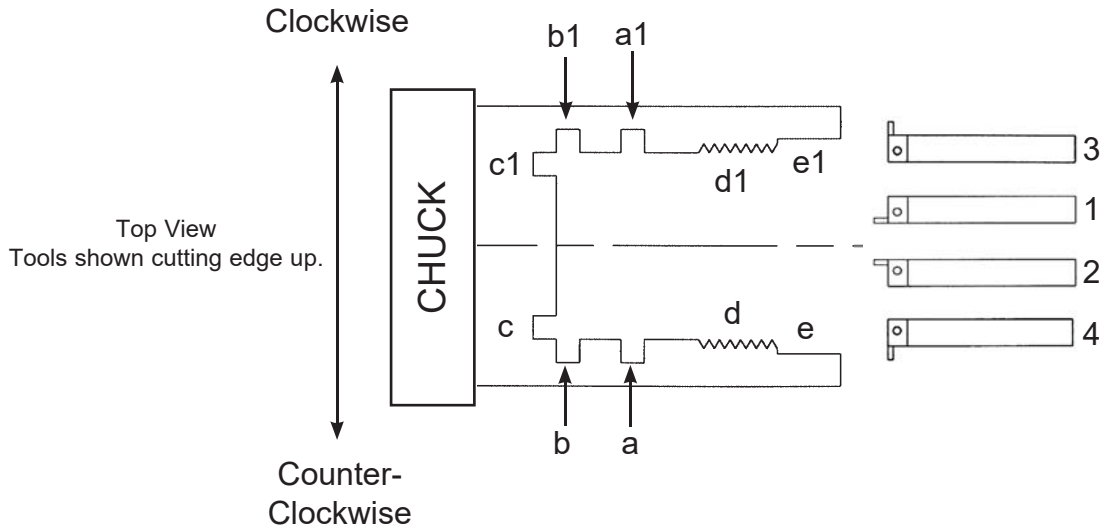

Internal Application Reference						
Description	Specification	Operation	Insert Orientation	Insert Page	Toolholder Compatibility	Toolholder Page
Groove Reference: a,a1,b,b1	For internal diameters .125" and larger; .004" - .250" insert widths in .001" increments; Depths of cut to .150"; 1/8", 3/16", 1/4", 5/16", 1/2" solid carbide shanks.	a,b	Left Hand	1-4	---	7-2
		a1 & b1	Right Hand	1-4	---	7-2
	For internal diameters .325" and larger; .004" - .125" insert widths in .001" increments; Depths of cut to .125"; For grooving, boring and generating profiles.	a & b	Left Hand	2-5	4	1-6
		a1 & b1	Right Hand	2-5	3	1-6
	For internal diameters 1" and larger; 2,3 & 4mm insert widths; Depths of cut .5".	a & b	---	6-1	4	1-8
		a1 & b1	---	6-1	3	1-8
Face Groove Reference: c,c1	For internal diameters .125" and larger; .004" - .250" insert widths in .001" increments; Depths of cut to .150"; 1/8", 3/16", 1/4", 5/16", 1/2" solid carbide shanks.	c	Right Hand	2-4	---	7-2
		c1	Left Hand	2-4	---	7-2
	.004" - .150" insert widths in .001" increments; Depths of cut 2.5 to 3 times width; For grooving, turning and generating profiles; Carbide and High Speed Steel.	c	Counter-Clockwise	2-10	1,4	7-1
	For internal diameters .325" and larger; .004" - .125" insert widths in .001" increments; Depths of cut to .125"; For grooving, boring and generating profiles.	c	Right Hand	2-5	2	2-6
		c1	Left Hand	2-5	1	2-6
	For internal diameters 1.547" and larger; 2,3,4,5 & 6mm insert widths; Depths of cut .5" to 1".	c	---	6-1	2	2-8
	c1	---	6-1	1	2-8	
Threading Reference: d,d1	For internal diameters .077" and larger; 4 Threads per Inch and greater; 1/8", 3/16", 1/4", 5/16", 1/2" solid carbide shanks.	d	Right Hand	4-4	---	7-2
		d1	Left Hand	4-4	---	7-2
	For internal diameters .187" and larger 6 Threads per Inch and greater 3/16", 1/4", 5/16", 3/8" solid carbide shanks.	d	Right Hand	4-6	---	7-2
		d1	Left Hand	4-6	---	7-2
	For internal diameters .325" and larger; 9 Threads per Inch and greater.	d	Left Hand	4-8	4	1-6
		d1	Right Hand	4-8	3	1-6
For internal diameters 1.250" and larger; 8 Threads per Inch and greater; Carbide and High Speed Steel.	d	Right Hand	4-10	4	7-1	
	d1	Left Hand	4-10	3	7-1	
Boring Reference: e,e1	For internal diameters .073" and larger; 1/8", 3/16", 1/4", 5/16", 1/2" solid carbide shanks.	e	Right Hand	3-4	---	7-2
		e1	Left Hand	3-4	---	7-2
	For internal diameters .165" and larger; WCGT, CD, TD and TP style inserts.	e	---	3-1	4	3-1
		e1	---	3-1	3	3-1

### KAISER TOOL COMPANY, INC.

### DURA-MAX® 2000 CARBIDE

**DURA-MAX® 2000** is a versatile and tough sub-micron grain carbide. Because of its high transverse rupture strength and fine grain structure, **DURA-MAX® 2000** performs well with interrupted cuts. This grade is recommended for cutting steel, cast iron, stainless steel and applications where there are interrupted cuts.

**DURA-MAX® 2000** approximates an ANSI C4/C5.

### DURA-MAX® 3000 CARBIDE

**DURA-MAX® 3000** is a hard and wear resistant sub-micron grain carbide. **DURA-MAX® 3000** is designed for light finish cuts. This grade is recommended for cutting steels and applications where precision finish cuts are required.

**DURA-MAX® 3000** approximates an ANSI C7/C8.

**DURA-MAX® 3000 inserts are only available on MINI-BORE® style inserts. See Section 3 of this catalog for further detail.**

### DURA-MAX® 4000 CARBIDE

**DURA-MAX® 4000** is a tough, general purpose sub-micron grain carbide. **DURA-MAX® 4000** is designed for roughing. This grade is recommended for cutting steels, stainless steel, nickel based alloys and applications where there are interrupted cuts.

**DURA-MAX® 4000** approximates an ANSI C5/C6.

**DURA-MAX® 4000 inserts are only available on MINI-BORE® style inserts. See Section 3 of this catalog for further detail.**

### DURA-MAX® 5000 CARBIDE

**DURA-MAX® 5000** is a hard, abrasion resistant, sub-micron grain carbide. Because of its hardness and fine grain structure, **DURA-MAX® 5000** provides excellent edge and corner retention. This grade is recommended for cutting abrasive materials, non-ferrous alloys, aluminum, plastic and applications where there are no interrupted cuts.

**DURA-MAX® 5000** approximates an ANSI C2/C3.

### DURA-MAX® 8000 CBN

**DURA-MAX® 8000** is a **CBN** tipped insert which provides an increased production rate, improved surface finish and dimensional control when used on high-temperature alloys such as inconel, nickel base alloys and materials with a hardness of Rockwell C-35 or harder.

**DURA-MAX® 8000 CBN tipped inserts are only available on MINI-BORE® style inserts. See Section 3 of this catalog for further detail.**

### DURA-MAX® 9000 PCD

**DURA-MAX® 9000** is a **PCD** tipped insert which provides an increased production rate, improved surface finish and dimensional control when used on non-ferrous and abrasive metals such as aluminum, brass and copper.

**DURA-MAX® 9000 PCD tipped inserts are only available on MINI-BORE® style inserts. See Section 3 of this catalog for further detail.**

### HIGH SPEED STEEL

**High Speed Steel** will cut most materials. It will take considerable abuse. However, high speed steel will not wear as well as carbide. We suggest the use of high speed steel for jobs of 500 cuts or less. It also works well on older machines which do not have high enough spindle speeds to take advantage of carbide.

**High Speed Steel** is an M42 grade.

## KAISER TOOL COMPANY, INC.

<p><b>TiN</b> (TITANIUM NITRIDE)</p>	<p>Excellent general purpose PVD coating for most applications. TiN offers excellent wear resistance and allows 10% - 30% increase in speeds and feeds. TiN also increases lubricity at cutting edge which reduces galling and welding. TiN is not recommended for Nickel alloys or Titanium.</p> <p>Color: Yellow/gold</p> <p>Thickness: 2-4 microns (.0001"-.0002")</p>
<p><b>TiCN</b> (TITANIUM CARBONITRIDE)</p>	<p>A multi-layer, PVD coating good for cutting Aluminum, Brass, Bronze, Copper and its alloys and Cast Iron. TiCN improves tool life and allows increased speeds and feeds. Should out-perform TiN in abrasive and difficult to machine materials. TiCN is harder and more impact resistant than TiN.</p> <p>Color: Gray/bronze</p> <p>Thickness: 2-6 microns (.0001"-.0004")</p>
<p><b>TiAlN</b> (TITANIUM ALUMINUM NITRIDE)</p>	<p>A high performance PVD coating which excels in cutting abrasive or difficult-to-machine materials such as Titanium, Inconel, Waspaloy, Hastelloy, High Nickel Alloys, harder varieties of Stainless Steel. Good performance with interrupted cuts, high temperatures and dry machining.</p> <p>Color: Dark gray/black</p> <p>Thickness: 2-4 microns (.0001"-.0002")</p>
<p><b>DIAMOND</b></p>	<p>Works well in cutting Aircraft Aluminum, Automotive Cast Aluminum, Copper, Brass, Graphite, Carbon, Various Plastics, Nylon, Natural Wood, Composite Woods and Kurtzite. Diamond coating is not recommended for cutting steels or other ferrous metals.</p> <p>Color: Silver</p> <p>Thickness: 2-6 microns (.0001"-.0004")</p>

**Note on coolants:**

THINBIT® inserts are compatible with all coolant types. Carbide and High Speed Steel give best performance on most materials when run flooded with coolant. Carbide does not perform well in thermal shock situations. Keep insert flooded or run dry.

**Note on coatings:**

Part numbers may not always include coating designation.

**KAISER TOOL COMPANY, INC.**

It is critical for small tooling to have correct set ups. Speeds and feeds, condition of toolholder, insert and machine, centerline heights, squareness of cutting edge to machine, rigid machine to toolholder relationships are vital for proper performance in all applications. The items listed are general guides, but will not solve all problems. Please call our sales office for additional assistance.

Problem	Things to try
<b>Grooving</b>	
Cutting oversized; Groove walls not square	Check insert squareness; Check toolholder condition; Check insert centerline; Check machine alignment; Decrease IPR
Chatter; Poor finish	Increase speed; Reduce feed; Check toolholder condition; Check centerline; Stub toolholder and review toolholder size and machine set up for maximum rigidity; Add coating; Add top rake
Built up edge; Insert chipping	Increase feed; Increase speed; Run with coolant; Use coated insert; Check insert centerline
Burr on part	Add chamfer to insert; Turn or bore diameter after groove
Insert breaking	Check insert squareness; Check toolholder condition; Check insert centerline; Check machine condition; Decrease IPR; Review speeds and feeds; Verify insert grade
Chip control	Increase feed; Use peck cycle; Mount with cutting edge down; Flood with coolant; Add chip control to insert
<b>Face Grooving</b>	
Cutting oversized; Groove walls not square	Check insert squareness; Check toolholder condition; Check insert centerline; Check machine alignment; Decrease IPR
Chatter; Poor finish	Increase speed; Reduce feed; Check toolholder condition; Check centerline; Stub toolholder and review toolholder size and machine set up for maximum rigidity; Add coating; Add top rake
Built up edge; Insert chipping	Increase feed; Increase speed; Run with coolant; Use coated insert; Check insert centerline
Burr on part	Add chamfer to insert; Turn or bore diameter after groove
Insert breaking	Check insert squareness; Verify clearance diameter; Check insert centerline; Check toolholder condition; Check machine condition; Decrease IPR; Review speeds and feeds; Verify insert grade
Chip control	Increase feed; Use peck cycle; Mount with cutting edge down; Flood with coolant; Add chip control to insert
<b>Boring/Turning</b>	
Chatter; Poor Finish	Increase speed; Reduce feed; Check toolholder condition; Check centerline; Verify chip evacuation; Verify coolant reaching cutting edge; Stub toolholder and review toolholder size and machine set up for maximum rigidity; Add coating; Add top rake
Built up edge; Insert chipping	Increase feed; Increase speed; Increase corner radius; Run with coolant; Use coated insert; Check insert centerline
Insert breaking	Check squareness; Verify clearance diameter; Check centerline; Check toolholder condition; Check machine condition; Decrease IPR; Review speeds and feeds; Verify insert grade
Chip control	Increase feed; Mount with cutting edge down; Flood with coolant; Add chip control to insert
<b>Threading</b>	
Chatter; Poor finish	Increase speed; Reduce depth of cut per pass; Check toolholder condition; Check centerline; Verify chip evacuation; Verify coolant reaching cutting edge; Stub toolholder and review toolholder size and machine set up for maximum rigidity; Add coating
Built up edge; Insert chipping	Increase depth of cut per pass; Increase speed; Increase corner radius; Run with coolant; Use coated insert; Check insert centerline
Insert breaking	Check squareness; Check centerline; Check toolholder condition; Check machine condition; Decrease depth of cut per pass; Review speeds and feeds; Verify insert grade
<b>Parting</b>	
Insert leading; Faces not square	Check insert squareness; Check toolholder condition; Check insert centerline; Check machine alignment; Decrease IPR; Add lead angle
Chatter; Poor finish	Increase speed; Reduce feed; Check toolholder condition; Check centerline; Stub toolholder and review toolholder size and machine set up for maximum rigidity; Add coating; Add top rake
Built up edge; Insert chipping	Increase feed; Increase speed; Run with coolant; Use coated insert; Check insert centerline
Burr on part	Chamfer before parting; Add lead angle to drop side of insert
Insert breaking	Check insert squareness; Check toolholder condition; Check insert centerline; Check machine condition; Decrease IPR; Review speeds and feeds; Verify insert grade
Chip control	Increase feed; Use peck cycle; Mount with cutting edge down; Flood with coolant; Add chip control to insert

### KAISER TOOL COMPANY, INC.

Phone: 888-THINBIT (888-844-6248) or (260) 484-3620 • Fax: 888-THINFAX (888-844-6329) or (260) 482-1881  
 www.thinbit.com • General E-mail: [thinbit@kaisertool.com](mailto:thinbit@kaisertool.com) • Orders: [orders@thinbit.com](mailto:orders@thinbit.com) • Quotes: [quotes@thinbit.com](mailto:quotes@thinbit.com)

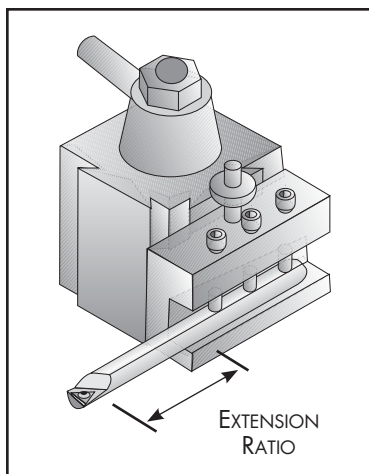

Extension Ratios					
Bar Diameter	Steel 4 x ø	Heavy Metal 6 x ø	Carbide 8 x ø	Shank Height	Steel
.156"	.625"	.937"	1.250"	.312"	1.250"
.187"	.750"	1.125"	1.500"	.375"	1.500"
.250"	1.000"	1.500"	2.000"	.500"	2.000"
.312"	1.250"	1.875"	2.500"	.625"	2.500"
.375"	1.500"	2.250"	3.000"	.750"	2.500"
.500"	2.000"	3.000"	4.000"	1.000"	2.500"
.625"	2.500"	3.750"	5.000"	1.250"	2.500"
.750"	3.000"				
1.000"	4.000"				

Extending a toolholder beyond these recommendations can cause excessive deflection which will result in poor surface finish and reduced insert life. These recommendations may need to be reduced if cutting materials with low machinability, taking heavy cuts or using the tooling in non-rigid machine set-ups.

### Toolholder Notes:

- To avoid burrs on your shanks, use only dog point screws. The use of cup point screws promotes burrs on the shanks and can result in problems removing or re-installing bars.
- Complete toolholders may be an assembly of several components each having an individual part number.
- Heavy Metal is a high density Tungsten based alloy that is very tough, stiff and vibration resistant.

### INTERNAL TOOL & FACE GROOVING CUTTING HEIGHTS

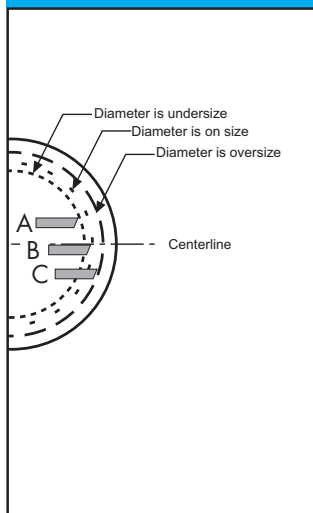

- Normal cutting forces cause tool deflection, therefore internal tools are manufactured to cut .002" to .010" above centerline.
- Setting tool above 'A' will cause diameter to be under desired size.
- Setting tool to cut at 'A' will cause insert to deflect to 'B' and cut desired diameter.
- Setting tool below 'A' will cause insert to deflect to 'C' and cause diameter to be oversized.
- Keep in mind if tools are mounted cutting edge toward floor, above center is toward floor.

### EXTERNAL TOOL CUTTING HEIGHTS

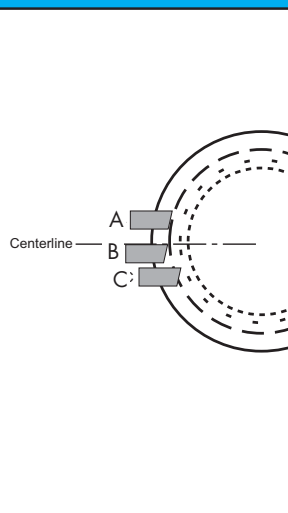

- External tools are manufactured to cut on center to .005" below centerline.
- Setting tool to cut at 'A' can cause heel of insert to rub or cause failure.
- Setting tool to cut at 'B' will cause insert to deflect slightly and cut at 'C'.
- Setting tool below 'C' can cause insert to grab or fail.
- Keep in mind if tools are mounted cutting edge toward floor, below center is toward ceiling.

### DEEPCROOVE® Head and Shank Compatibility Chart

Shank	Package	Page	Head	Clamp	Shank	Package	Page	Head	Clamp	Shank	Package	Page	Head	Clamp
DGS__XL	C	2-16	DGH4	DGC2	DGS__XR	B	2-16	DGH3	DGC1	DGS__ZR	N	2-8	DGH6	DGC6
	E	1-14	DGH2	DGC2		F	1-14	DGH1	DGC1		O	7-13	DGH3	DGC1
	S	7-14	DGH5	DGC5		T	7-14	DGH6	DGC6		Q	7-13	DGH1	DGC1
DGS__YR	D	2-16	DGH4	DGC2	DGS__YL	A	2-16	DGH3	DGC1	DGS__ZL	M	2-8	DGH5	DGC5
	G	1-14	DGH2	DGC2		H	1-14	DGH1	DGC1		P	7-13	DGH4	DGC2
	U	7-14	DGH5	DGC5		V	7-14	DGH6	DGC6		R	7-13	DGH2	DGC2

## KAISER TOOL COMPANY, INC.

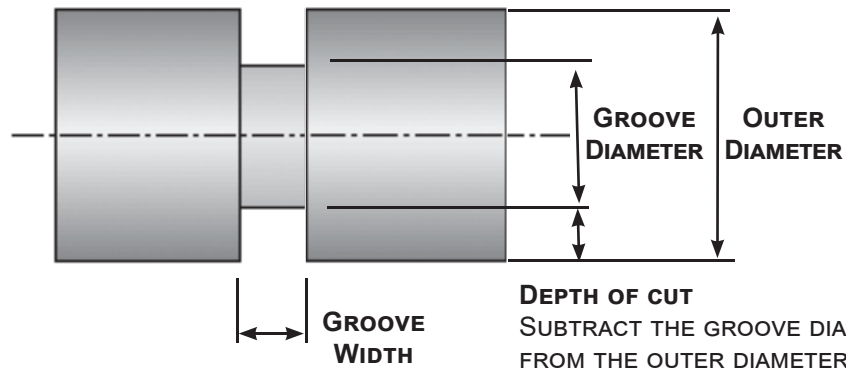

SUBTRACT THE GROOVE DIAMETER FROM THE OUTER DIAMETER AND DIVIDE BY 2.

Example: 1" outer diameter with .75" groove diameter.

$$\frac{1" - .75"}{2} = .125" \text{ depth of cut}$$

### External Grooving Applications

Decrease surface speed (SFM)

Increase feed (IPR)

Set tool on center to .005" below center. Keep smaller inserts closer to center.

Insert width:	Modify Parameter →												
	.004"	.020"	.040"	.060"	.080"	.100"	.120"	.140"	.160"	.180"	.200"	.220"	.250"
	Modify Parameter →												

### Internal Grooving Applications

Decrease surface speed (SFM)

Increase feed (IPR)

Set tool .002" to .010" above center. Keep smaller inserts closer to center.

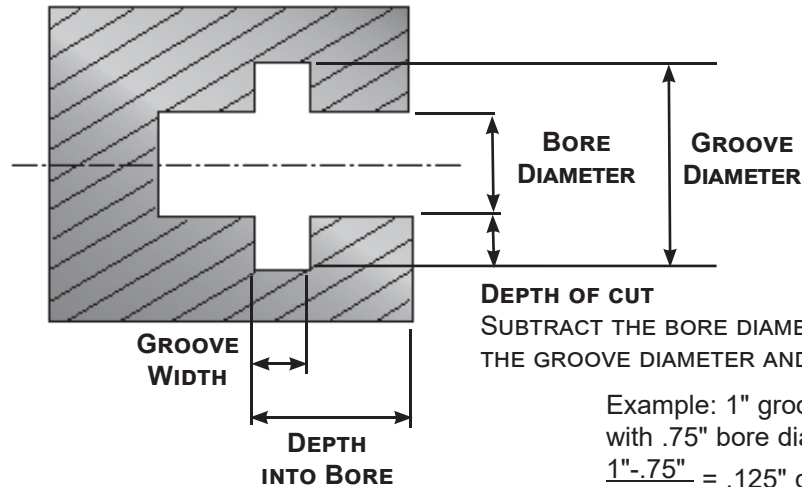

SUBTRACT THE BORE DIAMETER FROM THE GROOVE DIAMETER AND DIVIDE BY 2.

Example: 1" groove diameter with .75" bore diameter.

$$\frac{1" - .75"}{2} = .125" \text{ depth of cut}$$

Insert begins with:  
LGT, MGTI, GT

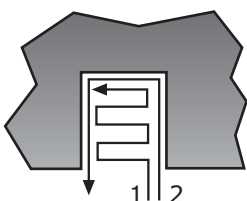

Insert begins with:  
DGI, DGMI

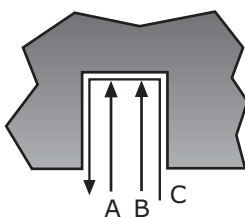

Cutting Paths

Use these diagrams for expanding the size of grooves.

Note: Side load on path 1 should be 10% to 30% of depth of cut on insert.

### KAISER TOOL COMPANY, INC.



## Speeds & Feeds - Grooving

Material To Be Cut		Carbide			High Speed Steel	
		Carbide Grade	Speed (SFM)	Feed (IPR)	Speed (SFM)	Feed (IPR)
Aluminum	2021-6061	DURA-MAX® 5000	1000	.002	500	.002
Brass		DURA-MAX® 5000	250	.001	75	.001
Bronze		DURA-MAX® 5000	250	.001	70	.001
Cast Iron	Gray	DURA-MAX® 5000	120-345	.0015-.004	35-125	.0015-.004
	Ductile	DURA-MAX® 2000	70-345	.001-.004	15-125	.001-.004
	Malleable	DURA-MAX® 2000	75-525	.0015-.003	35-170	.0015-.003
Copper	101-757	DURA-MAX® 5000	150-170	.002	85-90	.002
	834-978	DURA-MAX® 5000	600	.003	340	.003
Magnesium	AZ, AM, EZ, ZE, HK Types	DURA-MAX® 5000	1000	.002	500	.002
Nickel	Nickel 200-230	DURA-MAX® 5000	225	.002	85	.002
	Monel	DURA-MAX® 5000	150	.001-.0015	15-60	.001-.0015
	Inconel, Waspaloy	DURA-MAX® 5000	45	.002	15	.002
	Hastelloy	DURA-MAX® 5000	75-95	.002	10-15	.002
Plastic	Teflon (TFE, CTFE)	DURA-MAX® 5000	400	.002	250	.002
	Nylon	DURA-MAX® 5000	350-600	.002-.003	350	.002-.003
	Phenolic	DURA-MAX® 5000	600	.003	350	.003
	Glass Filled	DURA-MAX® 5000	250	.002	NA	NA
Stainless Steel	201-385	DURA-MAX® 5000	225-275	.001-.0015	65-85	.001-.0015
	405-446	DURA-MAX® 2000	300	.0011	90	.0011
	14-4, 15-5, 16-6, 17-4 PH	DURA-MAX® 2000	110-205	.0006-.0012	30-60	.0006-.0012
Steel	1005-1029	DURA-MAX® 2000	255-450	.001-.002	80-140	.001-.002
	1030-1055	DURA-MAX® 2000	115-370	.0009-.0015	35-115	.0009-.0015
	1060-1095	DURA-MAX® 2000	95-255	.0007-.001	30-80	.0007-.001
	10L45-10L50	DURA-MAX® 2000	130-450	.0009-.0015	40-140	.0009-.0015
	12L13-12L15	DURA-MAX® 2000	550-600	.003-.0035	225-280	.003-.0035
	41L30-41L50	DURA-MAX® 2000	65-350	.0007-.0015	20-110	.0007-.0015
	4140-4150	DURA-MAX® 2000	65-370	.0007-.0015	20-115	.0007-.0015
	4140 (35 HRc)	DURA-MAX® 2000	200	.001	70	.001
	8617-8622	DURA-MAX® 2000	125-390	.001-.0016	40-120	.001-.0016
	M1-M6	DURA-MAX® 2000	190	.0013	60	.0013
	H10-H19	DURA-MAX® 2000	65-255	.0007-.0011	20-80	.007-.0011
	D2-D7	DURA-MAX® 2000	150-205	.001	45-60	.001
	A2-A9, 01-07	DURA-MAX® 2000	150-205	.001	45-60	.001
	W1, W2	DURA-MAX® 2000	375	.0015	110	.0015
	M-50, 52100	DURA-MAX® 2000	65-275	.0007-.0015	20-85	.0007-.0015
Titanium	Ti-6Al-6V	DURA-MAX® 5000	95	.001	45	.001

THESE SPEEDS AND FEEDS ARE GIVEN AS A STARTING POINT ONLY AND MAY BE ADJUSTED UP OR DOWN DEPENDING ON CONDITIONS. ANY TIME THERE IS AN INTERRUPTED CUT IN YOUR OPERATION, **DURA-MAX® 2000** CARBIDE IS RECOMMENDED.

### FORMULA FOR CONVERSION FROM SFM TO RPM

SFM = SURFACE FEET PER MINUTE    RPM = REVOLUTIONS PER MINUTE    IPR = INCHES PER REVOLUTION    DIAMETER = CUTTING DIAMETER     $\pi = 3.14$

$$RPM = \frac{SFM \times 12}{(\pi) \times DIAMETER}$$

## KAISER TOOL COMPANY, INC.

Phone: 888-THINBIT (888-844-6248) or (260) 484-3620 • Fax: 888-THINFAX (888-844-6329) or (260) 482-1881  
www.thinbit.com • General E-mail: [thinbit@kaisertool.com](mailto:thinbit@kaisertool.com) • Orders: [orders@thinbit.com](mailto:orders@thinbit.com) • Quotes: [quotes@thinbit.com](mailto:quotes@thinbit.com)

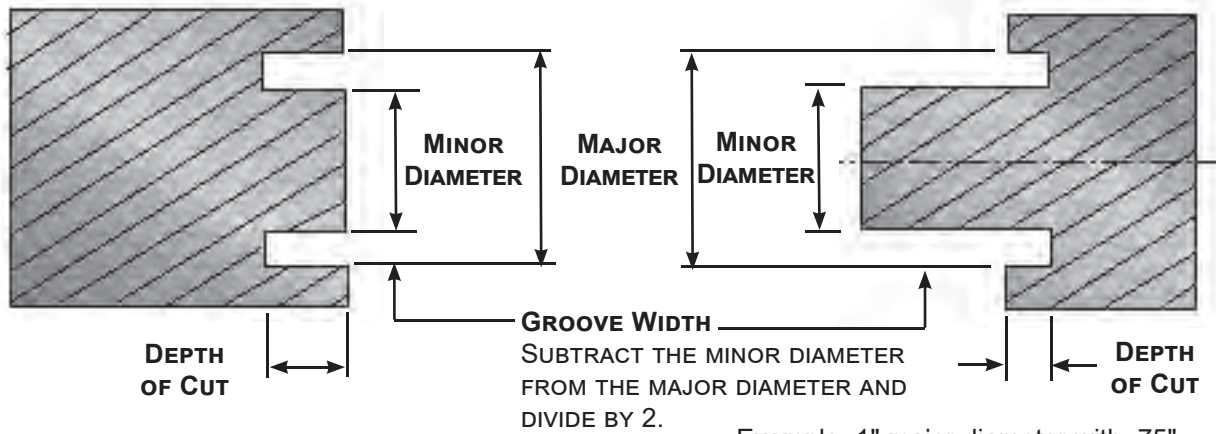

Example: 1" major diameter with .75" minor diameter.

$$\frac{1" - .75"}{2} = .125" \text{ Groove Width}$$

Setup Guide

### External Face Grooving Applications

Decrease surface speed (SFM)  
Increase feed (IPR)

Set tool on .002" to .010" above center. Keep smaller inserts closer to center.

Modify Parameter

Insert width:	.004"	.020"	.040"	.060"	.080"	.100"	.120"	.140"	.160"	.180"	.200"	.220"	.250"
---------------	-------	-------	-------	-------	-------	-------	-------	-------	-------	-------	-------	-------	-------

### Internal Face Grooving Applications

Decrease surface speed (SFM)  
Increase feed (IPR)

Set tool .002" to .010" above center. Keep smaller inserts closer to center.

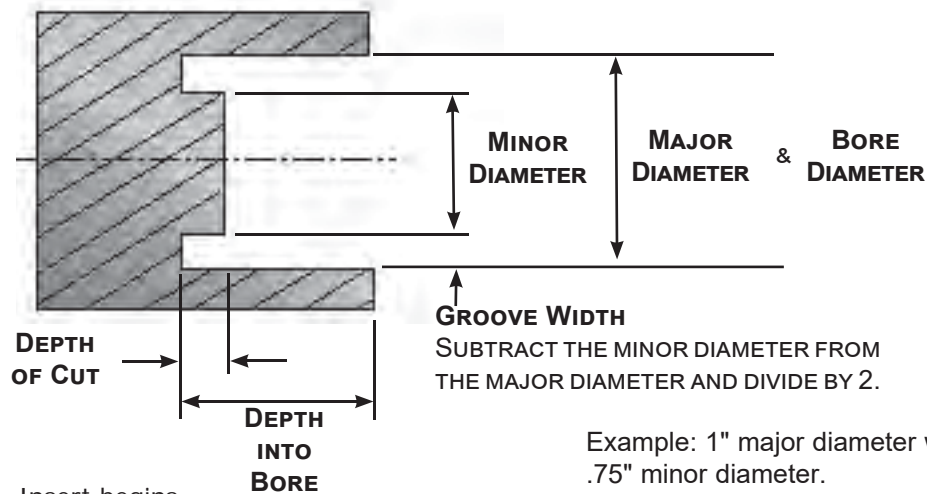

Example: 1" major diameter with .75" minor diameter.

$$\frac{1" - .75"}{2} = .125" \text{ Groove Width}$$

Insert begins with:  
LGT, MGT1, FT

Insert begins with:  
DGI, DGMI

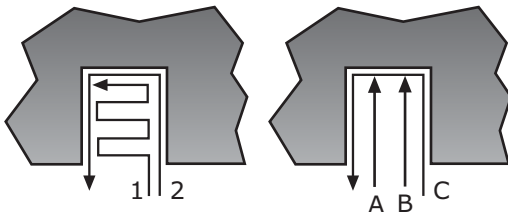

#### Cutting Paths

Use these diagrams for expanding the size of grooves.

Note: Side load on path 1 should be 10% to 30% of depth of cut on insert.

**KAISER TOOL COMPANY, INC.**

## Speeds & Feeds - Face Grooving

Material To Be Cut		Carbide			High Speed Steel	
		Carbide Grade	Speed (SFM)	Feed (IPR)	Speed (SFM)	Feed (IPR)
Aluminum	2021-6061	DURA-MAX <sup>®</sup> 5000	1000	.002-.003	525	.002-.003
Brass		DURA-MAX <sup>®</sup> 5000	250	.001	75	.001
Bronze		DURA-MAX <sup>®</sup> 5000	250	.001	70	.001
Cast Iron	Gray	DURA-MAX <sup>®</sup> 5000	300-500	.0017-.0027	35-115	.0017-.0027
	Ductile	DURA-MAX <sup>®</sup> 2000	250-425	.0013-.0027	30-75	.0013-.0027
	Malleable	DURA-MAX <sup>®</sup> 2000	300-600	.0013-.0027	35-120	.0013-.0027
Copper	101-757	DURA-MAX <sup>®</sup> 5000	450-550	.002	80-90	.0013-.0017
	834-978	DURA-MAX <sup>®</sup> 5000	600	.003	325	.0017
Magnesium	AZ, AM, EZ, ZE, HK Types	DURA-MAX <sup>®</sup> 5000	1000	.001-.002	650	.001-.002
Nickel	Nickel 200-230	DURA-MAX <sup>®</sup> 5000	225	.002	80	.001
	Monel	DURA-MAX <sup>®</sup> 5000	45-150	.001-.002	40-55	.001-.002
	Inconel, Waspaloy	DURA-MAX <sup>®</sup> 5000	75-100	.0013	10	.001
	Hastelloy	DURA-MAX <sup>®</sup> 5000	100-125	.0013-.0017	10-15	.001-.0015
Plastic	Teflon (TFE, CTFE)	DURA-MAX <sup>®</sup> 5000	400	.003	250	.003
	Nylon	DURA-MAX <sup>®</sup> 5000	350-600	.002-.003	350	.002-.003
	Phenolic	DURA-MAX <sup>®</sup> 5000	600	.003	350	.003
	Glass Filled	DURA-MAX <sup>®</sup> 5000	250	.002	N/A	N/A
Stainless Steel	201-385	DURA-MAX <sup>®</sup> 5000	225-275	.0013-.002	60-65	.001
	405-446	DURA-MAX <sup>®</sup> 2000	275	.002	90	.001
	14-4, 15-5, 16-6, 17-4 PH	DURA-MAX <sup>®</sup> 2000	125-150	.0013-.002	40-50	.001
Steel	1005-1029	DURA-MAX <sup>®</sup> 2000	400-500	.002-.003	75-110	.002-.003
	1030-1055	DURA-MAX <sup>®</sup> 2000	325-450	.0013-.0027	30-85	.0013-.0027
	1060-1095	DURA-MAX <sup>®</sup> 2000	325-400	.0016-.0027	30-70	.0016-.0027
	10L45-10L50	DURA-MAX <sup>®</sup> 2000	300-600	.0017-.0027	35-130	.0017-.0027
	12L13-12L15	DURA-MAX <sup>®</sup> 2000	500-600	.002-.003	105-130	.002-.003
	41L30-41L50	DURA-MAX <sup>®</sup> 2000	325-500	.0013-.0027	30-105	.0013-.0027
	4140-4150	DURA-MAX <sup>®</sup> 2000	325-450	.0013-.0027	30-95	.0013-.0027
	4140 (35 HRC)	DURA-MAX <sup>®</sup> 2000	350	.0013	45	.0013
	8617-8622	DURA-MAX <sup>®</sup> 2000	250-475	.001-.0023	30-90	.001-.0023
	M1-M6	DURA-MAX <sup>®</sup> 2000	350	.002	50	.001
	H10-H19	DURA-MAX <sup>®</sup> 2000	300-425	.001-.002	35-75	.001-.002
	D2-D7	DURA-MAX <sup>®</sup> 2000	300-375	.002	35-60	.0015-.002
	A2-A9, 01-07	DURA-MAX <sup>®</sup> 2000	300-375	.002	35-60	.0015-.002
	W1, W2	DURA-MAX <sup>®</sup> 2000	425	.002	75	.002
	M-50, 52100	DURA-MAX <sup>®</sup> 2000	350	.002	55	.002
Titanium	Ti-6Al-6V	DURA-MAX <sup>®</sup> 5000	95	.001	40	.002

THESE SPEEDS AND FEEDS ARE GIVEN AS A STARTING POINT ONLY AND MAY BE ADJUSTED UP OR DOWN DEPENDING ON CONDITIONS. ANY TIME THERE IS AN INTERRUPTED CUT IN YOUR OPERATION, **DURA-MAX<sup>®</sup> 2000** CARBIDE IS RECOMMENDED.

### FORMULA FOR CONVERSION FROM SFM TO RPM

SFM = SURFACE FEET PER MINUTE    RPM = REVOLUTIONS PER MINUTE

IPR = INCHES PER REVOLUTION

DIAMETER = CUTTING DIAMETER

$\pi = 3.14$

$$RPM = \frac{SFM \times 12}{(\pi) \times DIAMETER}$$

## KAISER TOOL COMPANY, INC.

Phone: 888-THINBIT (888-844-6248) or (260) 484-3620 • Fax: 888-THINFAX (888-844-6329) or (260) 482-1881  
 www.thinbit.com • General E-mail: [thinbit@kaisertool.com](mailto:thinbit@kaisertool.com) • Orders: [orders@thinbit.com](mailto:orders@thinbit.com) • Quotes: [quotes@thinbit.com](mailto:quotes@thinbit.com)

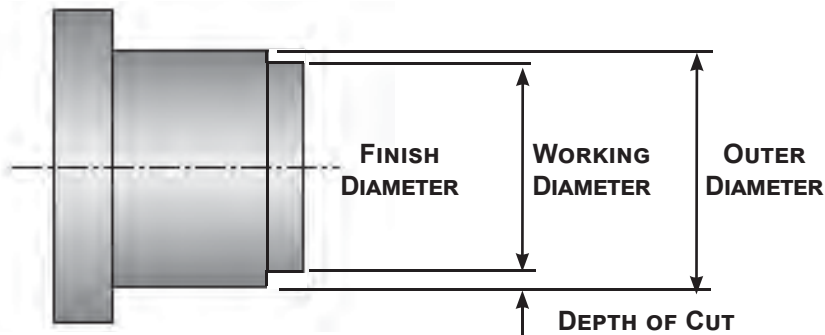

**DEPTH OF CUT**  
SUBTRACT THE WORKING DIAMETER FROM THE OUTER DIAMETER AND DIVIDE BY 2.

Example: 1" outer diameter with .976" working diameter.

$$\frac{1" - .976"}{2} = .012" \text{ depth of cut}$$

### Turning Applications

- Decrease surface speed (SFM)
- Increase feed (IPR)
- Increase depth of cut

Set tool on center to .005" below center. Keep smaller inserts closer to center.

Modify Parameter →

MBZ MBA MBE MBB MBF MBC MBG

Tool starts with:

BT21 BT31 BT41 BT51 BT61 BT81

Modify Parameter →

### Boring Applications

- Decrease surface speed (SFM)
- Increase feed (IPR)
- Increase depth of cut

Set tool .002" to .010" above center. Keep smaller tools closer to center.

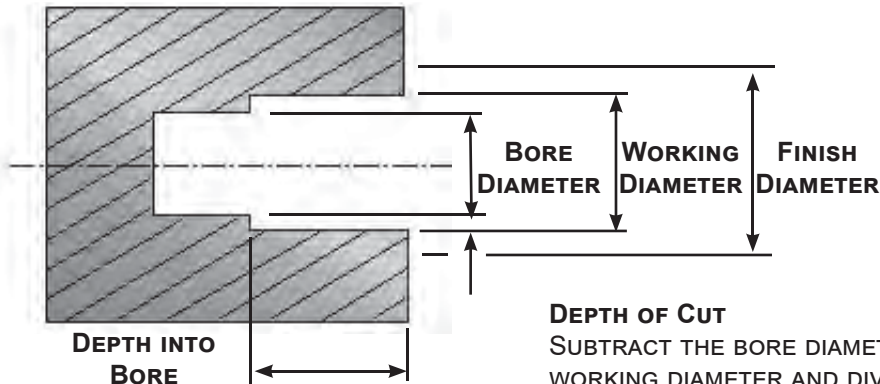

**DEPTH OF CUT**

SUBTRACT THE BORE DIAMETER FROM THE WORKING DIAMETER AND DIVIDE BY 2.

Example: 1" working diameter with .976" bore diameter.

$$\frac{1" - .976"}{2} = .012" \text{ depth of cut}$$

**Cutting Paths:**

- Internal tools designed for feeding into bore.
- External tools designed for feeding toward chuck.

**NUMBER OF PASSES**

SUBTRACT THE FINISH DIAMETER FROM THE OUTER DIAMETER AND DIVIDE BY 2 TIMES THE DEPTH OF CUT PER PASS.

Example: 1" outer diameter with .875" finish diameter and .012" per pass.

$$\frac{1" - .875"}{2 \times .012"} = 5.2 \text{ or } 6 \text{ passes}$$

Note: Leave 30% - 50% of depth of cut for finish pass.

### KAISER TOOL COMPANY, INC.

## Speeds & Feeds - MBE, MBF & MBG Style Inserts

Material To Be Cut		Carbide Grade	Speed (SFM)	Feed (IPR)	Depth of Cut		
					MBE	MBF	MBG
Aluminum	2021-6061	DURA-MAX® 5000	450-1000	.005-.012	.012	.014	.016
Brass		DURA-MAX® 5000	300-400	.002-.005	.010	.010	.012
Bronze		DURA-MAX® 5000	300-400	.002-.005	.009	.010	.012
Cast Iron	Gray	DURA-MAX® 5000	200-300	.005-.010	.010	.012	.015
	Ductile	DURA-MAX® 4000	200-300	.005-.010	.010	.012	.015
	Malleable	DURA-MAX® 4000	100-300	.005-.010	.010	.012	.015
Copper	101-757	DURA-MAX® 4000	400-750	.003-.005	.012	.014	.016
	834-978	DURA-MAX® 5000	300-700	.003-.005	.012	.014	.016
Magnesium	AZ, AM, EZ, ZE, HK Types	DURA-MAX® 5000	700-1300	.005-.012	.012	.014	.016
Nickel	Nickel 200-230	DURA-MAX® 4000	100-250	.002-.005	.008	.008	.008
	Monel	DURA-MAX® 4000	80-120	.0005-.001	.008	.008	.008
	Inconel, Waspaloy	DURA-MAX® 4000	70-95	.001-.003	.008	.008	.008
	Hastelloy	DURA-MAX® 4000	50-80	.001-.003	.008	.008	.008
Plastic	Teflon (TFE, CTFE)	DURA-MAX® 5000	500-850	.004-.008	.010	.012	.015
	Nylon	DURA-MAX® 5000	700-1000	.002-.005	.010	.012	.015
	Phenolic	DURA-MAX® 5000	700-1000	.005	.010	.012	.015
	Glass Filled	DURA-MAX® 5000	700-1000	.005	.008	.012	.015
Stainless Steel	201-385	DURA-MAX® 4000	100-225	.002-.004	.009	.010	.012
	405-446	DURA-MAX® 4000	100-225	.002-.004	.008	.009	.010
	14-4, 15-5, 16-6, 17-4 PH	DURA-MAX® 4000	300-400	.002-.004	.008	.009	.010
Steel	1005-1029	DURA-MAX® 4000	100-250	.003-.007	.010	.012	.015
	1030-1055	DURA-MAX® 4000	100-250	.003-.007	.010	.012	.015
	1060-1095	DURA-MAX® 4000	100-350	.003-.007	.010	.012	.015
	10L45-10L50	DURA-MAX® 4000	250-450	.006-.008	.010	.012	.015
	12L13-12L15	DURA-MAX® 4000	250-450	.004-.006	.010	.012	.015
	41L30-41L50	DURA-MAX® 4000	150-350	.003-.007	.010	.012	.015
	4140-4150	DURA-MAX® 4000	100-350	.003-.007	.010	.012	.015
	4140 (35 HRc)	DURA-MAX® 4000	90-125	.003-.007	.008	.008	.010
	8617-8622	DURA-MAX® 4000	100-200	.004-.008	.010	.012	.015
	M1-M6	DURA-MAX® 4000	100-200	.004-.008	.008	.010	.012
	H10-H19	DURA-MAX® 4000	100-200	.004-.008	.008	.010	.012
	D2-D7	DURA-MAX® 4000	100-200	.004-.008	.008	.010	.012
	A2-A9, 01-07	DURA-MAX® 4000	100-200	.004-.008	.008	.010	.012
	W1, W2	DURA-MAX® 4000	100-200	.004-.008	.008	.010	.012
	M-50, 52100	DURA-MAX® 4000	200-300	.005-.010	.010	.012	.015
	Titanium	Ti-6Al-6V	DURA-MAX® 5000	90-250	.001-.003	.008	.009

THESE SPEEDS AND FEEDS ARE GIVEN AS A STARTING POINT ONLY AND MAY BE ADJUSTED UP OR DOWN DEPENDING ON CONDITIONS. ANY TIME THERE IS AN INTERRUPTED CUT IN YOUR OPERATION, **DURA-MAX® 4000** CARBIDE IS RECOMMENDED.

### FORMULA FOR CONVERSION FROM SFM TO RPM

SFM = SURFACE FEET PER MINUTE    RPM = REVOLUTIONS PER MINUTE    IPR = INCHES PER REVOLUTION    DIAMETER = CUTTING DIAMETER     $\pi = 3.14$

$$RPM = \frac{SFM \times 12}{(\pi) \times DIAMETER}$$

## KAISER TOOL COMPANY, INC.

Phone: 888-THINBIT (888-844-6248) or (260) 484-3620 • Fax: 888-THINFAX (888-844-6329) or (260) 482-1881  
 www.thinbit.com • General E-mail: [thinbit@kaisertool.com](mailto:thinbit@kaisertool.com) • Orders: [orders@thinbit.com](mailto:orders@thinbit.com) • Quotes: [quotes@thinbit.com](mailto:quotes@thinbit.com)

## Speeds & Feeds - MBZ, MBA, MBB, MBC Style Inserts & MICROBIT® Solid Carbide Tools

Material To Be Cut		Carbide Grade			Depth of Cut		
		MBA, MBB, MBC, MBZ	Speed (SFM)	Feed (IPR)	MBA, MBZ, BT2, BT3	MBB, BT4, BT5	MBC, BT6, BT8
Aluminum	2021-6061	DURA-MAX® 5000	700-1400	.005-.012	.008	.008	.016
Brass		DURA-MAX® 5000	350-400	.001-.003	.006	.006	.012
Bronze		DURA-MAX® 5000	300-400	.001-.002	.006	.006	.012
Cast Iron	Gray	DURA-MAX® 5000	250-350	.004-.010	.007	.007	.015
	Ductile	DURA-MAX® 5000	250-350	.004-.010	.007	.007	.015
	Malleable	DURA-MAX® 5000	250-350	.004-.010	.007	.007	.015
Copper	101-757	DURA-MAX® 5000	600-800	.003-.005	.008	.008	.016
	834-978	DURA-MAX® 5000	600-800	.003-.005	.008	.008	.016
Magnesium	AZ, AM, EZ, ZE, HK Types	DURA-MAX® 5000	750-1500	.005-.012	.008	.008	.016
Nickel	Nickel 200-230	DURA-MAX® 5000	100-250	.002-.005	.004	.004	.008
	Monel	DURA-MAX® 5000	80-120	.001-.003	.004	.004	.008
	Inconel, Waspaloy	DURA-MAX® 5000	80-120	.001-.003	.004	.004	.008
	Hastelloy	DURA-MAX® 5000	80-120	.001-.003	.004	.004	.008
Plastic	Teflon (TFE, CTFE)	DURA-MAX® 5000	500-600	.003-.006	.007	.007	.015
	Nylon	DURA-MAX® 5000	700-800	.001-.003	.007	.007	.015
	Phenolic	DURA-MAX® 5000	700-800	.001-.003	.007	.007	.015
	Glass Filled	DURA-MAX® 5000	700-800	.001-.003	.005	.005	.015
Stainless Steels	201-385	DURA-MAX® 5000	100-250	.0015-.004	.005	.005	.010
	405-446	DURA-MAX® 5000	100-250	.0015-.004	.005	.005	.010
	14-4, 15-5, 16-6, 17-4 PH	DURA-MAX® 5000	300-400	.002-.004	.005	.005	.010
Steel	1005-1029	DURA-MAX® 3000/4000	100-300	.003-.007	.007	.007	.015
	1030-1055	DURA-MAX® 3000/4000	100-300	.003-.007	.007	.007	.015
	1060-1095	DURA-MAX® 3000/4000	150-400	.003-.005	.007	.007	.015
	10L45-10L50	DURA-MAX® 3000/4000	300-500	.004-.006	.007	.007	.015
	12L13-12L15	DURA-MAX® 3000/4000	300-500	.003-.005	.007	.007	.015
	41L30-41L50	DURA-MAX® 3000/4000	200-400	.003-.005	.007	.007	.015
	4140-4150	DURA-MAX® 3000/4000	150-400	.003-.005	.007	.007	.015
	4140 (35 HRC)	DURA-MAX® 3000/4000	90-125	.001-.004	.004	.004	.008
	8617-8622	DURA-MAX® 3000/4000	100-300	.002-.004	.007	.007	.015
	M1-M6	DURA-MAX® 3000/4000	150-250	.003-.008	.006	.006	.012
	H10-H19	DURA-MAX® 3000/4000	150-250	.003-.007	.006	.006	.012
	D2-D7	DURA-MAX® 3000/4000	150-250	.004-.010	.006	.006	.012
	A2-A9, 01-07	DURA-MAX® 3000/4000	150-250	.003-.008	.006	.006	.012
	W1, W2	DURA-MAX® 3000/4000	150-250	.003-.008	.006	.006	.012
	M-50, 52100	DURA-MAX® 3000/4000	300-400	.004-.010	.007	.007	.015
Titanium	Ti-6Al-6V	DURA-MAX® 5000	90-250	.001-.003	.005	.005	.010

THESE SPEEDS AND FEEDS ARE GIVEN AS A STARTING POINT ONLY AND MAY BE ADJUSTED UP OR DOWN DEPENDING ON CONDITIONS.  
 ANY TIME THERE IS AN INTERRUPTED CUT IN YOUR OPERATION, **DURA-MAX® 3000/4000** CARBIDE IS RECOMMENDED.

### FORMULA FOR CONVERSION FROM SFM TO RPM

SFM = SURFACE FEET PER MINUTE    RPM = REVOLUTIONS PER MINUTE    IPR = INCHES PER REVOLUTION    DIAMETER = CUTTING DIAMETER    π = 3.14

$$RPM = \frac{SFM \times 12}{(P) \times DIAMETER}$$

## KAISER TOOL COMPANY, INC.

Phone: 888-THINBIT (888-844-6248) or (260) 484-3620 • Fax: 888-THINFAX (888-844-6329) or (260) 482-1881  
 www.thinbit.com • General E-mail: [thinbit@kaisertool.com](mailto:thinbit@kaisertool.com) • Orders: [orders@thinbit.com](mailto:orders@thinbit.com) • Quotes: [quotes@thinbit.com](mailto:quotes@thinbit.com)



Speeds & Feeds - DURA-MAX® 9000 (PCD Tipped) Insert					
Material To Be Cut	Speed (SFM)	Feed (IPR)	Depth of Cut		
			MBA	MBB	MBC
Aluminum (High Silicon)	1000-2000	.003-.010	.001-.007	.002-.008	.003-.012
Bronze, Brass	800-1500	.003-.010	.001-.007	.002-.008	.003-.012
Copper Alloys	800-1200	.003-.010	.001-.007	.002-.008	.003-.012
Fiberglass	500-900	.001-.005	.001-.007	.002-.008	.003-.012
Green Carbide	500-1400	.001-.004	.001-.007	.002-.008	.003-.012
Monel	1000-2000	.003-.010	.001-.007	.002-.008	.003-.012
Phenolic	500-900	.001-.005	.001-.007	.002-.008	.003-.012
Plastics	500-900	.001-.004	.001-.007	.002-.008	.003-.012

THESE SPEEDS AND FEEDS ARE GIVEN AS A STARTING POINT ONLY AND MAY BE ADJUSTED UP OR DOWN DEPENDING ON CONDITIONS. ANY TIME THERE IS AN INTERRUPTED CUT IN YOUR OPERATION, **DURA-MAX® 3000 & 4000** CARBIDES ARE RECOMMENDED.

Speeds & Feeds - DURA-MAX® 8000 (CBN Tipped) Insert					
Material To Be Cut	Speed (SFM)	Feed (IPR)	Depth of Cut		
			MBA	MBB	MBC
52100 (58-62 HRC)	300-500	.003-.007	.001-.007	.002-.008	.003-.012
Hardened Alloy Steel	200-400	.003-.007	.001-.007	.002-.008	.003-.012
Hardened High Carbon Steel	300-500	.003-.007	.001-.007	.002-.008	.003-.012
Hardened Tool Steel	150-300	.002-.005	.001-.007	.002-.008	.003-.012
Ni-Hard Cast Iron	100-300	.007-.015	.001-.007	.002-.008	.003-.012
Pearlitic Gray Cast Iron	800-1800	.007-.015	.001-.007	.002-.008	.003-.012
Powdered Metal	350-500	.003-.007	.001-.007	.002-.008	.003-.012
Stellite	100-200	.002-.004	.001-.007	.002-.008	.003-.012
Super Alloys	400-900	.003-.007	.001-.007	.002-.008	.003-.012
Thermal Spray Co Based	200-600	.002-.005	.001-.007	.002-.008	.003-.012
Thermal Spray Ni Based	150-450	.002-.007	.001-.007	.002-.008	.003-.012

**FORMULA FOR CONVERSION FROM SFM TO RPM**

SFM = SURFACE FEET PER MINUTE  
RPM = REVOLUTIONS PER MINUTE  
IPR = INCHES PER REVOLUTION  
DIAMETER = CUTTING DIAMETER  
 $\pi = 3.14$

$$RPM = \frac{SFM \times 12}{(\pi) \times DIAMETER}$$

**ANSI STANDARD INSERT IDENTIFICATION SYSTEM**

References to "insert type" in this catalog are based upon the ANSI B212.4-1995 system. The two letter codes refer to shape and relief angle. The use of four letter codes adds the tolerances and type (or configuration) to the first two letters. Following are the codes used for our inserts:

**SHAPE**

C	Diamond (80°)
T	Triangle
W	Trigon

**RELIEF ANGLE**

C	17°
P	11°
D	15°

**TOLERANCES**

	Insert I.C.	Thickness
A	+/- .0002"	+/- .001
C	+/- .0005"	+/- .001
G	+/- .001"	+/- .002

**TYPE (CONFIGURATION)**

B	With Hole & Countersink
D	Smaller than .250" I.C. With Hole
H	Hole, Countersink & Molded Chipbreaker
G	Hole, Countersink & Ground Chipbreaker
T	Hole, Countersink & Ground Chipbreaker One Side

**KAISER TOOL COMPANY, INC.**

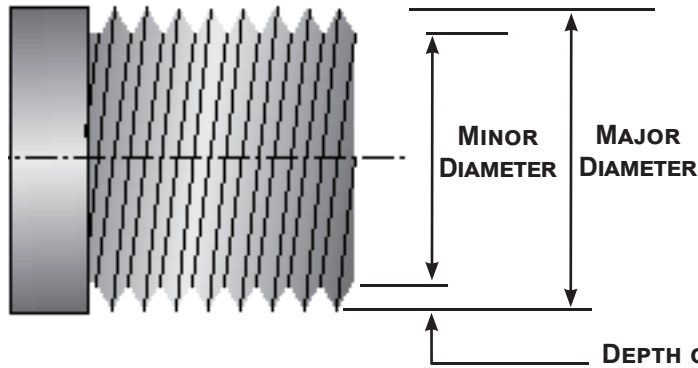

**DEPTH OF THREAD**  
SUBTRACT THE MINOR DIAMETER FROM THE MAJOR DIAMETER AND DIVIDE BY 2.

Example: 1" major diameter with .754" minor diameter.  
 $\frac{1 - .754}{2} = .123$ " depth of thread

### External Threading Applications

Decrease surface speed (SFM)  
Increase depth of cut per pass  
Set tool on center to .005" below center. Keep smaller inserts closer to center.

	Modify Parameter															
	MGTT				STT LTT LGTT LGAT											
Tool starts with:	TT21	TT20	TT31	TT30	TT41	TT40	TT51	TT50	TT61	TT60	TT81	TT80				
			AT31		AT41		AT51		AT61							
	Modify Parameter															

### Internal Threading Applications

Decrease surface speed (SFM)  
Decrease depth of cut per pass  
Set tool .002" to .010" above center. Keep smaller tools closer to center.

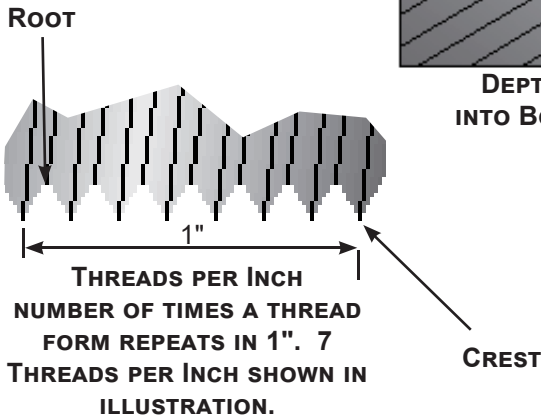
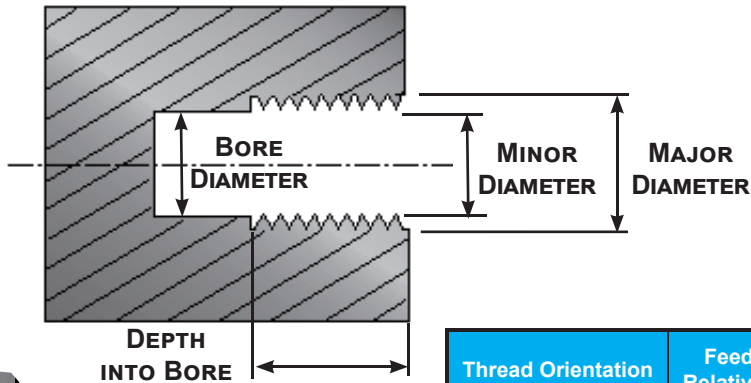

**PITCH = 1/THREADS PER INCH**  
**DEPTH OF INTERNAL THREADS = .54127 x PITCH**  
**DEPTH OF EXTERNAL THREADS = .86603 x PITCH**

Thread Orientation	Feed Direction Relative to Spindle	Chuck Rotation
Right Hand, External	Toward	Counter-Clockwise
	Away	Clockwise
Left Hand, External	Toward	Clockwise
	Away	Counter-Clockwise
Right Hand, Internal	Toward	Counter-Clockwise
	Away	Clockwise
Left Hand, Internal	Toward	Clockwise
	Away	Counter-Clockwise

## KAISER TOOL COMPANY, INC.

## Speeds & Feeds - Threading

Material To Be Cut		Carbide Grade	Speed (SFM)		Infeed Per Pass (IPR)	
			Carbide	HSS	1st Pass	Last Pass
Aluminum	2021-6061	DURA-MAX® 5000	100-200	80-150	.020	.001
Brass		DURA-MAX® 5000	200-300	50-150	.010	.001
Bronze		DURA-MAX® 5000	200-300	50-150	.010	.001
Cast Iron	Gray, Ductile, Malleable	DURA-MAX® 2000	85-140	25-50	.015	.0005
Copper	101-757, 834-978	DURA-MAX® 5000	100-200	30-100	.010	.001
Magnesium	AZ, AM, EZ, ZE, HK Types	DURA-MAX® 5000	100-200	80-150	.020	.001
Nickel	Nickel 200-230, Monel, Inconel	DURA-MAX® 5000	40-100	20-25	.015	.001
	Waspaloy, Hastelloy	DURA-MAX® 5000	40-100	20-25	.015	.001
Plastic	Teflon (TFE, CTFE)	DURA-MAX® 5000	250-400	100-300	.015	.001
	Nylon	DURA-MAX® 5000	250-400	100-300	.015	.001
	Phenolic	DURA-MAX® 5000	250-400	100-300	.015	.001
	Glass Filled	DURA-MAX® 5000	250-400	NA	.015	.001
Stainless Steel	201-385	DURA-MAX® 5000	65-100	8-20	.015	.001
	405-446	DURA-MAX® 2000	65-100	8-20	.015	.001
	14-4, 15-5, 16-6, 17-4 PH	DURA-MAX® 2000	65-100	8-20	.015	.001
Steel	1005-1029, 1030-1055	DURA-MAX® 2000	50-150	30-40	.015	.001
	1060-1095, 10L45-10L50	DURA-MAX® 2000	50-150	30-40	.015	.001
	12L13-12L15, 41L30-41L50	DURA-MAX® 2000	50-150	30-40	.015	.001
	4140-4150, 4140 (35 HRC)	DURA-MAX® 2000	50-150	30-40	.015	.001
	8617-8622, M1-M6	DURA-MAX® 2000	50-150	30-40	.015	.001
	D2-D7, A2-A9, 01-07	DURA-MAX® 2000	50-150	30-40	.015	.001
	W1, W2, M-50, 52100	DURA-MAX® 2000	50-150	30-40	.015	.001
Titanium	Ti-6Al-6V	DURA-MAX® 5000	40-65	5-9	.020	.0005

### Single Point Threading - Roughing Infeed Depth per Pass

(Based on Equal Areas of Material Removal per Pass)

Pass	Threads Per Inch													
	8	10	11	12	13	14	16	18	20	24	28	32	36	40
1st	.017	.015	.013	.013	.012	.011	.011	.011	.010	.009	.008	.008	.007	.008
2nd	.028	.024	.022	.022	.020	.019	.018	.018	.016	.015	.013	.013	.011	.013
3rd	.037	.032	.029	.029	.026	.024	.023	.023	.021	.019	.016	.017	.015	
4th	.045	.038	.035	.035	.032	.029	.028	.028	.025	.023	.019			
5th	.052	.044	.040	.040	.036	.034	.032	.032	.028					
6th	.058	.049	.045	.044	.041	.038	.036							
7th	.064	.054	.049	.049	.045	.041								
8th	.069	.059	.053											
9th	.074													

Note: One or more finish passes will be necessary to finish the thread

THESE SPEEDS AND FEEDS ARE GIVEN AS A STARTING POINT ONLY AND MAY BE ADJUSTED UP OR DOWN DEPENDING ON CONDITIONS. ANY TIME THERE IS AN INTERRUPTED CUT IN YOUR OPERATION, **DURA-MAX® 2000** CARBIDE IS RECOMMENDED.

FORMULA FOR CONVERSION FROM SFM TO RPM

SFM = SURFACE FEET PER MINUTE    RPM = REVOLUTIONS PER MINUTE

IPR = INCHES PER REVOLUTION

DIAMETER = CUTTING DIAMETER

$\pi = 3.14$

$$RPM = \frac{SFM \times 12}{\pi \times DIAMETER}$$

## KAISER TOOL COMPANY, INC.

Phone: 888-THINBIT (888-844-6248) or (260) 484-3620 • Fax: 888-THINFAX (888-844-6329) or (260) 482-1881  
www.thinbit.com • General E-mail: [thinbit@kaisertool.com](mailto:thinbit@kaisertool.com) • Orders: [orders@thinbit.com](mailto:orders@thinbit.com) • Quotes: [quotes@thinbit.com](mailto:quotes@thinbit.com)

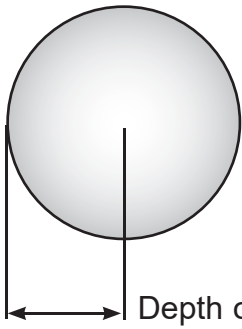

Depth of Cut to part

Solid:

Divide outside diameter by 2

Example: 1" outside diameter

$$\frac{1"}{2} = .5" \text{ depth of cut to part}$$

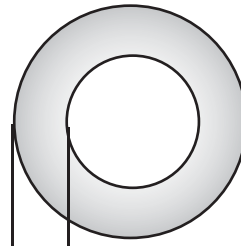

Depth of Cut to part

Tubing:

Subtract inside diameter from outside diameter and divide by 2

Example: 1" outside diameter with .5" inside diameter.

$$\frac{1" - .5"}{2} = .25" \text{ depth of cut to part}$$

### External Parting Applications

Decrease surface speed (SFM)

Increase depth of cut per pass

Set tool on center to .005" below center. Keep smaller inserts closer to center.

Modify Parameter →

Tool starts with:	LGPT025 SPT025	LGPT045 SPT045	LGPT062 SPT062	LGPT085 LPT085	LGPT115 LPT115
-------------------	-------------------	-------------------	-------------------	-------------------	-------------------

## KAISER TOOL COMPANY, INC.

Speeds & Feeds - Parting						
Material To Be Cut		Carbide Grade	Carbide		High Speed Steel	
			Speed (SFM)	Feed (IPR)	Speed (SFM)	Feed (IPR)
Aluminum	2021-6061	DURA-MAX® 5000	650-1100	.002-.004	300-500	.002-.004
Brass		DURA-MAX® 5000	200-350	.001-.003	50-100	.001-.003
Bronze		DURA-MAX® 5000	200-350	.001-.003	50-100	.001-.003
Cast Iron	Gray	DURA-MAX® 5000	100-350	.0015-.005	30-125	.0015-.005
	Ductile	DURA-MAX® 2000	200-400	.003-.006	100-200	.003-.006
	Malleable	DURA-MAX® 2000	250-550	.003-.006	100-200	.003-.006
Copper	101-757	DURA-MAX® 5000	150-300	.002-.004	50-150	.002-.004
	834-978	DURA-MAX® 5000	250-600	.002-.006	100-450	.002-.006
Magnesium	AZ, AM, EZ, ZE, HK Types	DURA-MAX® 5000	600-1000	.002-.004	300-500	.002-.004
Nickel	Nickel 200-230	DURA-MAX® 5000	200-350	.002-.004	50-100	.002-.004
	Monel	DURA-MAX® 5000	100-250	.0025-.003	30-80	.002-.003
	Inconel, Waspaloy	DURA-MAX® 5000	50-150	.002-.004	25-75	.001-.003
	Hastelloy	DURA-MAX® 5000	50-150	.002-.004	25-75	.001-.003
Plastic	Teflon (TFE, CTFE)	DURA-MAX® 5000	300-600	.002-.006	100-300	.002-.006
	Nylon	DURA-MAX® 5000	250-400	.002-.005	NA	NA
	Phenolic	DURA-MAX® 5000	250-400	.002-.005	200-350	.002-.005
	Glass Filled	DURA-MAX® 5000	200-350	.002-.007	NA	NA
Stainless Steel	201-385	DURA-MAX® 5000	200-350	.002-.004	75-150	.001-.003
	405-446	DURA-MAX® 2000	250-450	.002-.003	50-100	.001-.003
	14-4, 15-5, 16-6, 17-4 PH	DURA-MAX® 2000	200-350	.002-.003	50-100	.001-.003
Steel	1005-1029	DURA-MAX® 2000	250-400	.0015-.004	100-200	.0015-.004
	1030-1055	DURA-MAX® 2000	200-325	.001-.003	75-100	.001-.003
	1060-1095	DURA-MAX® 2000	150-300	.001-.003	60-100	.001-.003
	10L45-10L50	DURA-MAX® 2000	250-400	.001-.003	100-200	.001-.003
	12L13-12L15	DURA-MAX® 2000	250-550	.002-.005	100-300	.002-.005
	41L30-41L50	DURA-MAX® 5000	150-400	.002-.005	45-150	.002-.005
	4140-4150	DURA-MAX® 2000	150-400	.002-.005	45-150	.002-.005
	4140 (35 HRc)	DURA-MAX® 2000	100-250	.001-.004	30-75	.001-.004
	8617-8622	DURA-MAX® 2000	150-400	.002-.004	50-150	.001-.004
	M1-M6	DURA-MAX® 2000	150-300	.001-.002	50-150	.001-.002
	H10-H19	DURA-MAX® 2000	100-350	.001-.002	50-150	.001-.002
	D2-D7	DURA-MAX® 2000	100-300	.001-.002	50-100	.001-.002
	A2-A9, 01-07	DURA-MAX® 2000	100-300	.001-.0025	100-200	.001-.002
	W1, W2	DURA-MAX® 2000	200-400	.002-.0035	75-175	.001-.003
	M-50, 52100	DURA-MAX® 2000	175-350	.0015-.004	50-125	.001-.0035
Titanium	Ti-6Al-6V	DURA-MAX® 5000	150-350	.0015-.004	30-100	.001-.003

THESE SPEEDS AND FEEDS ARE GIVEN AS A STARTING POINT ONLY AND MAY BE ADJUSTED UP OR DOWN DEPENDING ON CONDITIONS. ANY TIME THERE IS AN INTERRUPTED CUT IN YOUR OPERATION, **DURA-MAX® 2000** CARBIDE IS RECOMMENDED.

#### FORMULA FOR CONVERSION FROM SFM TO RPM

SFM = SURFACE FEET PER MINUTE    RPM = REVOLUTIONS PER MINUTE    IPR = INCHES PER REVOLUTION    DIAMETER = CUTTING DIAMETER     $\pi = 3.14$

$$RPM = \frac{SFM \times 12}{(\pi) \times DIAMETER}$$

### KAISER TOOL COMPANY, INC.

Phone: 888-THINBIT (888-844-6248) or (260) 484-3620 • Fax: 888-THINFAX (888-844-6329) or (260) 482-1881  
 www.thinbit.com • General E-mail: [thinbit@kaisertool.com](mailto:thinbit@kaisertool.com) • Orders: [orders@thinbit.com](mailto:orders@thinbit.com) • Quotes: [quotes@thinbit.com](mailto:quotes@thinbit.com)

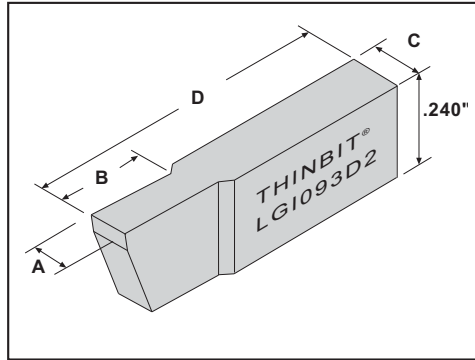

**FRONT RAKE:**  
 CARBIDE: Primary 10° honed, Secondary 15°  
 HIGH SPEED STEEL: 15°  
**BACK CLEARANCE:** 2-1/2° both sides  
**SIDE CLEARANCE:** 0° both sides  
**RADIUS:** Sharp corner through full radius available  
**TOP RAKE:** 0°  
**LEAD ANGLE:** 0°  
**'A' TOLERANCE:**  
 .004" - .063": +.0009"/-.0000"  
 .064" - .125": +.001"/-.001"

<b>PRODUCT INFORMATION</b>	<ul style="list-style-type: none"> <li>This insert style will cut to within 1/16" of a shoulder. To work against a shoulder see Page 1-10.</li> <li>Sub-micron grain <b>DURA-MAX® 2000</b> and <b>5000</b> Carbides and High Speed Steel.</li> <li>Inserts available with TiN, TiAlN, TiCN and Diamond coating.</li> </ul>
----------------------------	--

TECHNICAL SECTIONS	PRODUCT DEMONSTRATION	SPEEDS AND FEEDS	APPLICATION REFERENCE	TROUBLESHOOTING
	 <a href="http://www.thinbit.com/gr10-1">www.thinbit.com/gr10-1</a>	PG 9-10	PGS 9-3 & 9-4	PG 9-7

## ORDERING INSTRUCTIONS

Complete the **ORDER CODE** in the table below that represents your selection of groove width and insert grade.

**EXAMPLE:**

The **ORDER CODE** for an .093" groove width insert in **DURA-MAX® 2000** is:

**LGI 093 D2**

Specify the Tool Width 'A' \_\_\_\_\_ ↑

SPECIFICATIONS		ORDER CODE						INFORMATION		
Insert Width Range	Depth of Cut	Insert Grades <small>See Page 9-5 for expanded material descriptions and Page 9-10 for Speeds and Feeds information</small>			Add-ons <small>Use 'Order Code' and Add</small>			Blank Width	Overall Length	Toolholder Catalog Section 7 & 10
'A'	'B'	DURA-MAX® 2000 Carbide <small>For Steel &amp; Interrupted Cutting</small>	DURA-MAX® 5000 Carbide <small>For Aluminum &amp; Nonferrous</small>	High Speed Steel	Full Radius <small>Page 8-3</small>	Corner Radius <small>Page 8-3</small>	Coating <small>Page 9-6</small>	'C'	'D'	Use Toolholders Beginning With
.004"-.034"	3 x 'A'	SGI ___ D2	SGI ___ D5	SGI ___ HS	add 'FR'	add 'CR___' (indicate size in .xxx")	TiN add 'C' TiCN add 'D' TiAlN add 'E' Diamond add 'F'	.068"	.650"	'S' 'EM' 'ROM'
.035"-.063"	.100"									'L' 'EM' 'ROM'
.064"-.125"	1.5 x 'A'	LGI ___ D2	LGI ___ D5	LGI ___ HS				.130"	.721"	Section 7 Page 10-5 through 10-8

## KAISER TOOL COMPANY, INC.





Insert Shown in Right Hand Toolholder

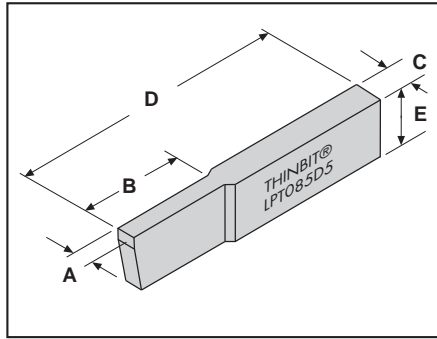

**FRONT RAKE:**

CARBIDE: Primary 7° honed, Secondary 15°  
HIGH SPEED STEEL: 15° on SPT025HS,  
7° all others

**BACK CLEARANCE:** 0° SPT045HS and  
SPT062HS; 1° all others

**SIDE CLEARANCE:** 1°

**RADIUS:** None

**TOP RAKE:** 0°

**LEAD ANGLE:** 0°

**'A' TOLERANCE:** .025" - .115": +.001"/-.001"

<b>PRODUCT INFORMATION</b>	<ul style="list-style-type: none"> <li>This insert style will cut to within 1/16" of a shoulder.</li> <li>.025", .045", .062", .085" and .115"</li> <li>Parting off up to 1" diameter</li> <li>Centered</li> <li>Sub-micron grain <b>DURA-MAX® 2000</b> and <b>5000</b> Carbides and High Speed Steel.</li> <li>Inserts available with TiN, TiAlN, TiCN and Diamond coating.</li> </ul>
----------------------------	---

TECHNICAL SECTIONS	PRODUCT DEMONSTRATION	SPEEDS AND FEEDS	APPLICATION REFERENCE	TROUBLESHOOTING
	 <a href="http://www.thinbit.com/qr10-2">www.thinbit.com/qr10-2</a>	PG 9-20	PG 9-4	PG 9-7

## ORDERING INSTRUCTIONS

Select the **ORDER CODE** in the table below that represents your selection of groove width and insert grade.

**EXAMPLE:**

The **ORDER CODE** for an .085" wide parting insert in **DURA-MAX® 5000** is:  
**LPT085D5**

SPECIFICATIONS		ORDER CODE				INFORMATION						
Groove Width	Depth of Cut	Insert Grades See Pages 9-5 for expanded material descriptions and Page 9-20 for Speeds and Feeds information			Coatings See Page 9-6 for expanded coating descriptions				Blank Width	Overall Length	Blank Height	Toolholder Catalog Section 7 & 10
'A'	'B'	DURA-MAX® 2000 Carbide For Steel & Interrupted Cutting	DURA-MAX® 5000 Carbide For Aluminum & Nonferrous	High Speed Steel	Use uncoated part number and add coating code				'C'	'D'	'E'	Use Toolholders Beginning With
					TiN	TiCN	TiAlN	Diamond				
.025"	.200"	SPT025D2	SPT025D5	SPT025HS						.650"		'S' 'EM' 'ROM'  Page 10-5 through 10-8
.045"	.500"	SPT045D2	SPT045D5	SPT045HS	add 'C'	add 'D'	add 'E'	add 'F'	.068"	1.000"	.240"	
.062"		SPT062D2	SPT062D5	SPT062HS								
.085"	.500"	LPT085D2	LPT085D5								.238"	'L' 'EM' 'ROM'  Section 7 Page 10-5 through 10-8
.115"		LPT115D2	LPT115D5		add 'C'	add 'D'	add 'E'	add 'F'	.125"	1.000"	.232"	

## KAISER TOOL COMPANY, INC.



Insert Shown in Right Hand Toolholder

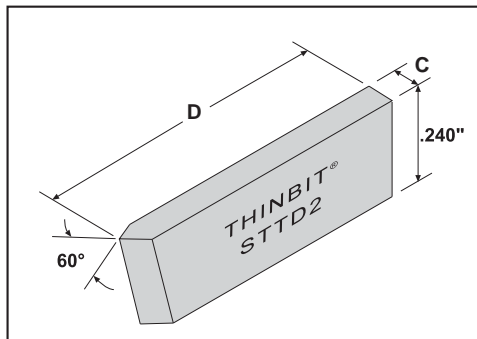

FRONT RAKE: 15°  
 RADIUS: .002" or .000"  
 TOP RAKE: 0°  
 PROFILE: 60°

<b>PRODUCT INFORMATION</b>	<ul style="list-style-type: none"> <li>• External threading within .046" of a shoulder.</li> <li>• Internal threading with 1.250" minimum bore diameter.</li> <li>• 8 Threads Per Inch and greater.</li> <li>• Sub-micron grain <b>DURA-MAX® 2000</b> and <b>5000</b> Carbides and High Speed Steel.</li> <li>• Inserts can be coated with TiN, TiAlN, TiCN and Diamond coating.</li> </ul>
----------------------------	---

<b>TECHNICAL SECTIONS</b>	<b>PRODUCT DEMONSTRATION</b>	<b>SPEEDS AND FEEDS</b>	<b>APPLICATION REFERENCE</b>	<b>TROUBLESHOOTING</b>
	 <a href="http://www.thinbit.com/qr10-3">www.thinbit.com/qr10-3</a>	PG 9-18	PG 9-4	PG 9-7

## ORDERING INSTRUCTIONS

Complete the **ORDER CODE** in the table below that represents your selection of Threads Per Inch and insert grade.

**EXAMPLE:**

The **ORDER CODE** for an 15-56 TPI insert in **DURA-MAX® 2000** is:  
**STTD2**

SPECIFICATIONS		ORDER CODE							INFO.		
Insert Orientation	Threads Per Inch	Insert Grades <small>See Page 9-5 for expanded material selections and Page 9-18 for Speeds and Feeds information</small>			Coatings <small>See Page 9-6 for Expanded Coating Descriptions</small>				Blank Width 'C'	Overall Length 'D'	Toolholder Catalog Section 7 & 10  Use Toolholders Beginning With
		DURA-MAX® 2000 Carbide <small>For Steel &amp; Interrupted Cutting</small>	DURA-MAX® 5000 Carbide <small>For Aluminum &amp; Non-ferrous</small>	High Speed Steel	Use Uncoated Part Number and Add Coating Code						
					TiN	TiCN	TiAlN	Diamond			
Centered For either right hand or left hand	15 to 56	STTD2	STTD5	STTHS					.068"	.650"	'S'  Page 10-5 through 10-8
	Greater than 56	STTD21	STTD51	STTHS1	add 'C'	add 'D'	add 'E'	add 'F'			
	8 to 56	LTTD2	LTTD5	LTTTHS					.130"	.721"	'L'  Section 7 Page 10-5 through 10-8
	Greater than 56	LTTD21	LTTD51	LTTTHS1	add 'C'	add 'D'	add 'E'	add 'F'			

## KAISER TOOL COMPANY, INC.

FRONT RAKE: 7° on SGP068HS; 15° all others

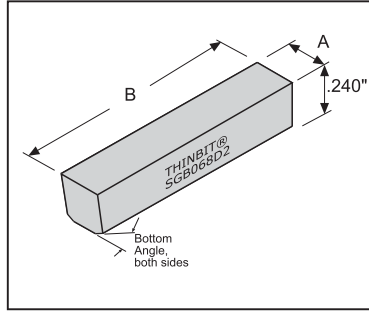

## GROUND BLANK ORDERING INSTRUCTIONS

Select the **ORDER CODE** in the table below that represents your selection of blank width and insert grade.

**EXAMPLE:**

The **ORDER CODE** for a .068" wide blank and .654" length in

**DURA-MAX® 2000** is:

**SGB068D2**

SPECIFICATIONS			ORDER CODE			INFO.
Blank Width 'A'	Overall Length 'B'	Bottom Angle	Insert Grades See Page 9-5 for expanded material descriptions			Use Toolholders Beginning With
			DURA-MAX® 2000 Carbide For Steel & Interrupted Cutting	DURA-MAX® 5000 Carbide For Aluminum & Nonferrous	High Speed Steel	
.068"	.654"	0°	SGB068D2	SGB068D5	SGB068HS	'S'
	1.004"	0°	SGP068D2	SGP068D5	SGP068HS	
.125"	1.004"	0°	LGP125D2	LGP125D5		'L'
.130"	.725"	10°	LGB130D2	LGB130D5	LGB130HS	

## SET ORDERING INSTRUCTIONS

Select the **ORDER CODE** in the table below that represents your selection of insert width(s) and insert grade.

For '1 Each' set types, specify the size range with the 'Order Code'

**EXAMPLE:**

The **ORDER CODE** for a '1 Each' set type, in **DURA-MAX® 2000**

with a groove width range of .010"-.030" is: **SSET2D2**

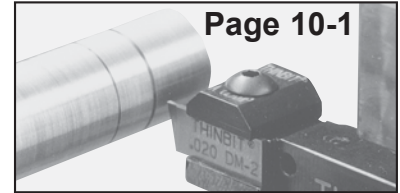

SPECIFICATIONS			ORDER CODE		
Toolholder Type	Set Type	Insert Width 'A' See Page 10-1	Insert Grades See Page 9-5 for expanded material descriptions and Page 9-10 for Speeds and Feeds information		
			DURA-MAX® 2000 Carbide For Steel & Interrupted Cutting Uncoated	DURA-MAX® 5000 Carbide For Aluminum & Non-ferrous Uncoated	High Speed Steel
Inserts only; Use toolholders beginning with 'S'  Page 10-5 through 10-8	1 Each, by .001" increments Inserts Only	.004"-.009"	SSET1D2	SSET1D5	SSET1HS
		.010"-.030"	SSET2D2	SSET2D5	SSET2HS
		.031"-.050"	SSET3D2	SSET3D5	SSET3HS
		.051"-.063"	SSET4D2	SSET4D5	SSET4HS
Inserts only; Use toolholders beginning with 'L'  Section 7 Page 10-5 through 10-8	1 Each, by .001" increments Inserts Only	.064"-.084"	LSET1D2	LSET1D5	LSET1HS
		.085"-.105"	LSET2D2	LSET2D5	LSET2HS
		.106"-.125"	LSET3D2	LSET3D5	LSET3HS

## KAISER TOOL COMPANY, INC.

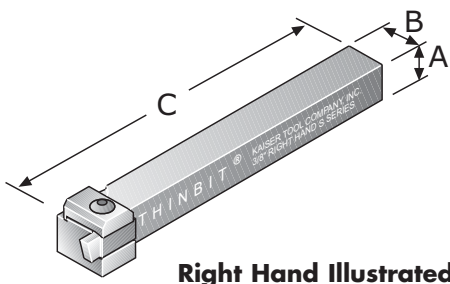

**Right Hand Illustrated**

### FLUSHTOP ORDERING INSTRUCTIONS

Select the **ORDER CODE** in the table below that represents your selection of shank orientation and dimensions.

**EXAMPLE:**

The **ORDER CODE** for a .375" shank, right hand flushtop tool for inserts beginning with 'L' is:  
**LFT38R**

SPECIFICATIONS				ORDER CODE							
Shank Orientation	Shank Dimensions			Toolholder Package Includes Shank, Clamp and Hardware		Replacement Parts					
	'A'	'B'	'C'	For Inserts Beginning With		Clamp	Screw	Wrench	Pin		
				'S'	'L'						
Right Hand <small>Use with right hand and centered inserts</small>	.312"	.312"	4.840"	SFT56R	---	Clamp A	S5608	W1005	P0308		
				---	LFT56R					Clamp C	S3808
	.375"	.375"	4.840"	SFT38R	---					Clamp A	S5608
				---	LFT38R					Clamp C	S3808
	.500"	.500"	4.840"	SFT12R	LFT12R					Clamp C	S3808
.625"	.625"	4.840"	SFT58R	LFT58R	Clamp C	S3808					
Left Hand <small>Use with left hand and centered inserts</small>	.312"	.312"	4.840"	SFT56L	---	Clamp A	S5608	W1005	P0308		
				---	LFT56L	Clamp C	S3808				
	.375"	.375"	4.840"	SFT38L	---	Clamp A	S5608				
				---	LFT38L	Clamp C	S3808				
	.500"	.500"	4.840"	SFT12L	LFT12L	Clamp C	S3808				
.625"	.625"	4.840"	SFT58L	LFT58L	Clamp C	S3808					

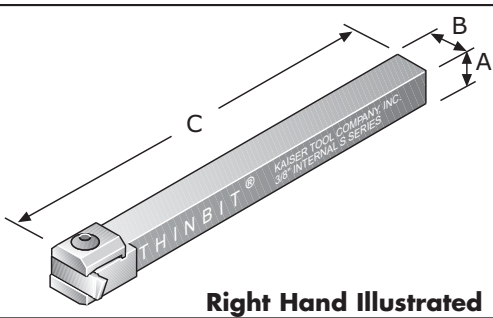

**Right Hand Illustrated**

### HARDINGE ORDERING INSTRUCTIONS

Select the **ORDER CODE** in the table below that represents your selection of shank orientation and dimensions.

**EXAMPLE:**

The **ORDER CODE** for a .375" shank, right hand tool for inserts beginning with 'L' is:  
**LHA38**

SPECIFICATIONS					ORDER CODE								
Shank Orientation	Shank Dimensions			Minimum Bore Diameter <small>with 'S' inserts; add .071" for 'L' inserts</small>	Toolholder Package Includes Shank, Clamp and Hardware		Replacement Parts						
	'A'	'B'	'C'		For Inserts Beginning With		Clamp	Screw	Wrench	Pin			
					'S'	'L'							
Right Hand <small>Use with left hand and centered inserts</small>	.375"	.375"	4.840"	1.050"	SHA38	---	Clamp C	S3808	W1005	P0204			
					---	LHA38							
.500"	.500"	4.840"	1.290"	SHA12	LHA12								
Left Hand <small>Use with right hand and centered inserts</small>	.375"	.375"	4.840"	1.050"	SHA38	---							
					---	LHA38							
	.500"	.500"	4.840"	1.290"	SHA12	LHA12							

### KAISER TOOL COMPANY, INC.

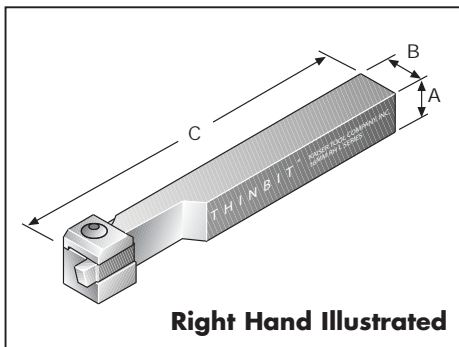

### SWISS SCREW ORDERING INSTRUCTIONS

Select the **ORDER CODE** in the table below that represents your selection of shank orientation and dimensions.

**EXAMPLE:**

The **ORDER CODE** for a .500" shank, right hand tool for inserts beginning with 'L' is:

**LSS12R**

SPECIFICATIONS				ORDER CODE							
Shank Orientation	Shank Dimensions			Toolholder Package Includes Shank, Clamp and Hardware		Replacement Parts					
	'A'	'B'	'C'	For Inserts Beginning With		Clamp		Screw		Wrench	Pin
				'S'	'L'	'S'	'L'	'S'	'L'		
Right Hand  Use with right hand and centered inserts	.375"	.375"	4.840"	SSS38R	---	A	--	S5608	---	W1005	P0305
	.500"	.500"		SSS12R	LSS12R	A	C	S5608	S3808		
	8mm	8mm		SSS08RM	---	A	--	S5608	---		
	10mm	10mm		SSS10RM	---	A	--	S5608	---		
	12mm	12mm		SSS12RM	LSS12RM	A	C	S5608	S3808		
	16mm	16mm		SSS16RM	LSS16RM	C	C	S3808	S3808		
Left Hand  Use with left hand and centered inserts	.375"	.375"	4.840"	SSS38L	---	A	--	S5608	---	W1005	P0305
	.500"	.500"		SSS12L	LSS12L	A	C	S5608	S3808		
	8mm	8mm		SSS08LM	---	A	--	S5608	---		
	10mm	10mm		SSS10LM	---	A	--	S5608	---		
	12mm	12mm		SSS12LM	LSS12LM	A	C	S5608	S3808		
	16mm	16mm		SSS16LM	LSS16LM	C	C	S3808	S3808		

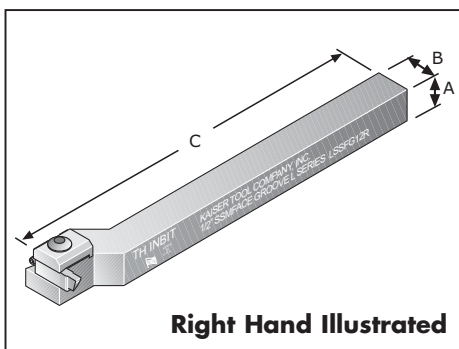

### SWISS FACE ORDERING INSTRUCTIONS

Select the **ORDER CODE** in the table below that represents your selection of shank orientation and dimensions.

**EXAMPLE:**

The **ORDER CODE** for a .375" shank, right hand tool for inserts beginning with 'L' is:

**LSSFG38R**

SPECIFICATIONS				ORDER CODE						
Shank Orientation	Shank Dimensions			Toolholder Package Includes Shank, Clamp and Hardware		Replacement Parts				
	'A'	'B'	'C'	For Inserts Beginning With		Clamp	Screw		Wrench	Pin
				'S'	'L'		'S'	'L'		
Right Hand  Use with left hand and centered inserts for counter-clockwise rotation	.375"	.375"	4.840"	SSSFG38R	LSSFG38R	Clamp C		S3808	W1005	P0203
	.500"	.500"	4.840"	SSSFG12R	LSSFG12R			S3808		
	10mm	10mm	4.840"	SSSFG10RM	LSSFG10RM			S5452		
	12mm	12mm	4.840"	SSSFG12RM	LSSFG12RM			S5452		
	16mm	16mm	4.840"	SSSFG16RM	LSSFG16RM			S3808		

### KAISER TOOL COMPANY, INC.

# LITTLE BIT® REVERSIBLE TOOLHOLDER, STRAIGHT & 90°

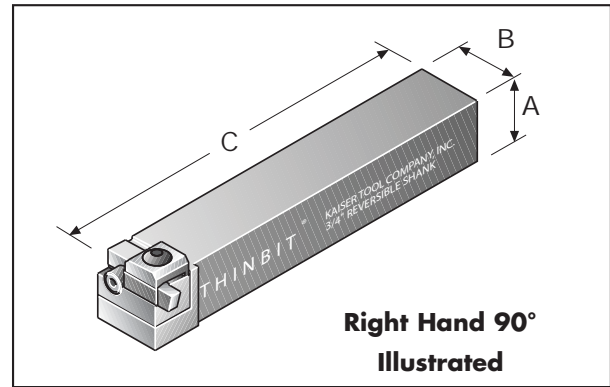
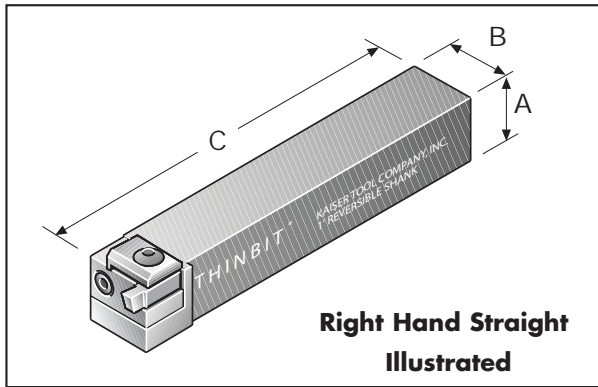

## ORDERING INSTRUCTIONS

Select the **ORDER CODE** in the table below that represents your selection of shank orientation and dimensions.

**EXAMPLE:**

The **ORDER CODE** for a .750" shank and a 90° right hand tool for inserts beginning with 'L' is:

**LRI3434R**

SPECIFICATIONS				ORDER CODE									
Shank Orientation	Shank Dimensions			Toolholder Package Includes Shank, Head, Clamp and Hardware		Head Only Includes Clamp and Hardware For Inserts Beginning With		Replacement Parts					
	'A'	'B'	'C'	For Inserts Beginning With		'S'	'L'	Head Screws	Head Wrenches	Head Pin	Shank	Clamp	Clamp Hardware
				'S'	'L'	'S'	'L'						
<b>Straight</b> Right Hand or Left Hand  Use as right hand with right hand inserts; Use as left hand with left hand inserts; Use as either hand with centered inserts.	.375"	.750"	4.840"	SRE3438	LRE3438	SREH34	LREH34	1 each: S3808 S2808	1 each: W1005 W1009		RS3438	Clamp C	Screw: S3808  Wrench: W1005
	.500"			SRE3412	LRE3412						RS3412		
	.625"			SRE3458	LRE3458						RS3458		
	.750"			SRE3434	LRE3434						RS3434		
	.750"	1.000"	4.840"	SRE0134	LRE0134	SREH01	LREH01	1 each: S3812 S2808	1 each: W1005 W1009	P0305	RS0134	Clamp C	Screw: S3808  Wrench: W1005
	1.000"			SRE0101	LRE0101						RS0101		
	1.000"	1.250"	4.840"	SRE1401	LRE1401	SREH14	LREH14	1 each: S3816 S2808	1 each: W1005 W1009		RS1401	Clamp C	Screw: S3808  Wrench: W1005
	1.250"			SRE1414	LRE1414						RS1414		
<b>90°</b> Right Hand Use with left hand and centered inserts	.375"	.750"	4.840"	SRI3438R	LRI3438R	SRIH34R	LRIH34R	1 each: S3808 S2812	1 each: W1005 W1009		RS3438	Clamp C	Screw: S3808  Wrench: W1005
	.500"			SRI3412R	LRI3412R						RS3412		
	.625"			SRI3458R	LRI3458R						RS3458		
	.750"			SRI3434R	LRI3434R						RS3434		
	.750"	1.000"	4.840"	SRI0134R	LRI0134R	SRIH01R	LRIH01R	1 each: S3812 S2812	1 each: W1005 W1009	P0305	RS0134	Clamp C	Screw: S3808  Wrench: W1005
1.000"	SRI0101R			LRI0101R	RS0101								
<b>90°</b> Left Hand Use with right hand and centered inserts	.375"	.750"	4.840"	SRI3438L	LRI3438L	SRIH34L	LRIH34L	1 each: S3808 S2812	1 each: W1005 W1009		RS3438	Clamp C	Wrench: W1005
	.500"			SRI3412L	LRI3412L						RS3412		
	.625"			SRI3458L	LRI3458L						RS3458		
	.750"			SRI3434L	LRI3434L						RS3434		
	.750"	1.000"	4.840"	SRI0134L	LRI0134L	SRIH01L	LRIH01L	1 each: S3812 S2812	1 each: W1005 W1009	P0305	RS0134	Clamp C	Wrench: W1005
	1.000"			SRI0101L	LRI0101L						RS0101		

## KAISER TOOL COMPANY, INC.

Phone: 888-THINBIT (888-844-6248) or (260) 484-3620 • Fax: 888-THINFAX (888-844-6329) or (260) 482-1881  
 www.thinbit.com • General E-mail: thinbit@kaisertool.com • Orders: orders@thinbit.com • Quotes: quotes@thinbit.com



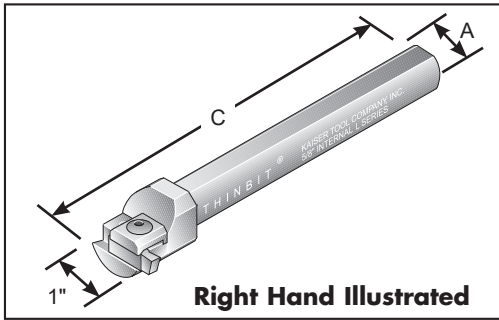

### ROUND INTERNAL ORDERING INSTRUCTIONS

Select the **ORDER CODE** in the table below that represents your selection of shank orientation and dimensions.

**EXAMPLE:**

The **ORDER CODE** for a .625", 5.5" long round shank for inserts beginning with 'L' is:

**LR5806**

SPECIFICATIONS				ORDER CODE					
Shank Orientation	Minimum Bore Diameter without pin	Shank Dimensions		Toolholder Package Includes Shank, Clamp and Hardware For Inserts Beginning With		Replacement Parts			
		'A'	'C'	'S'	'L'	Clamp	Screw	Wrench	Pin
Right Hand or Left Hand  Use as right hand with left hand inserts; Use as left hand with right hand inserts; Use as either hand with centered inserts.	1.125"	.500"	5.500"	SR1206	---	Clamp C	S3808	W1005	P0305
		.625"		SR5806	---				
		.750"		SR3406	---				
		1.000"		SR0106	---				
	1.187" (1.250" for insert beginning with 'LGT')	.500"	5.500"	---	LR1206				
		.625"		---	LR5806				
		.750"		---	LR3406				
		1.000"		---	LR0106				
		11.875"	---	LR0112					

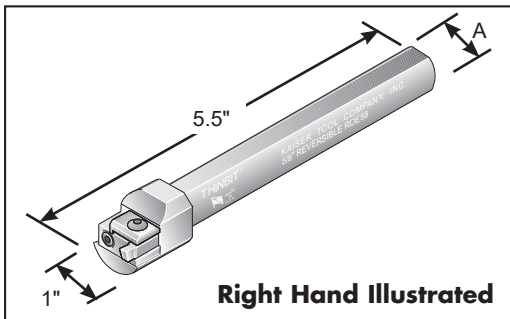

### ROUND REVERSIBLE ORDERING INSTRUCTIONS

Select the **ORDER CODE** in the table below that represents your selection of shank dimensions.

**EXAMPLE:**

The **ORDER CODE** for a .625" round shank for inserts beginning with 'L' is:

**LROE58**

SPECIFICATIONS				ORDER CODE						
Shank Orientation	Shank Dimensions 'A'	Toolholder Package Includes Shank, Head, Clamp and Hardware For Inserts Beginning With		Replacement Parts						
		'S'	'L'	Head Only Includes Clamp and Hardware For Inserts Beginning With		Head Screws	Head Wrenches	Shank	Clamp	Clamp Hardware
Right Hand or Left Hand  Use as right hand with right hand inserts; Use as left hand with left hand inserts; Use as either hand with centered inserts.	.500"	SROE12	LROE12	SROEH	LROEH	1 each: S5806 S2810	1 each: W1006 W1009	RROE12	Clamp C	Screw: S3808  Wrench: W1005
	.625"	SROE58	LROE58					RROE58		
	.750"	SROE34	LROE34					RROE34		
	1.000"	SROE01	LROE01					RROE01		

### KAISER TOOL COMPANY, INC.

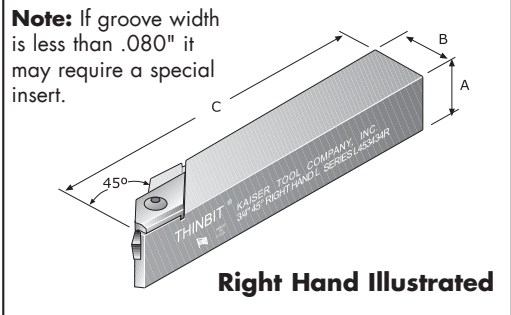

## 45° ORDERING INSTRUCTIONS

Select the **ORDER CODE** in the table below that represents your selection of shank orientation and dimensions.

**EXAMPLE:**

The **ORDER CODE** for a .750" shank, right hand tool for inserts beginning with 'L' is:  
**L453434R**

SPECIFICATIONS				ORDER CODE					
Shank Orientation	Shank Dimensions			Toolholder Package Includes Shank, Clamp and Hardware		Replacement Parts			
	'A'	'B'	'C'	For Inserts Beginning With		Clamp	Screw	Wrench	Pin
				'S'	'L'				
Right Hand Use with left hand and centered inserts for counter-clockwise rotation	.375"	.750"	4.840"	S453438R	L453438R	Clamp Q	S3808	W1005	* C0509
	.500"			S453412R	L453412R				
	.625"			S453458R	L453458R				
	.750"			S453434R	L453434R				
	1.000"	1.000"		S450101R	L450101R				
Left Hand Use with right hand and centered inserts for clockwise rotation	.375"	.750"	4.840"	S453438L	L453438L	Clamp R	S3808	W1005	* C0509
	.500"			S453412L	L453412L				
	.625"			S453458L	L453458L				
	.750"			S453434L	L453434L				
	1.000"	1.000"		S450101L	L450101L				

\* Roll Pin sizes may have changed due to manufacturing updates. Toolholders will be shipped with the correct item. Replacement pin (C0509) will contain two items (P0204 & P0305) to accommodate either revision.

### KAISER TOOL COMPANY, INC.



# MINI-BORE®

SECTION 3

CD, TD, TP AND TRIGON STYLE INDEXABLE BORING BARS



# THINBIT® 24/7

[www.thinbit.com](http://www.thinbit.com)

E-MAIL: [thinbit@kaisertool.com](mailto:thinbit@kaisertool.com)

ORDERS: [orders@thinbit.com](mailto:orders@thinbit.com)

QUOTES: [quotes@thinbit.com](mailto:quotes@thinbit.com)

For more information  
about our services,  
please visit  
[www.kaiseraserimages.com](http://www.kaiseraserimages.com)



# Laser Images®

PRECISION LASER ENGRAVING  
LOGOS • GRAPHICS  
BAR CODES • SERIALIZATION  
SCALES • PRODUCT IDENTIFICATION



# THINBIT®

SWISS TOOLING  
SOLUTIONS FOR

GROOVING • THREADING • PARTING • BORING • TURNING  
FACE GROOVING • SPECIALS • FORM TOOLS

ASK FOR OUR SWISS FLYER OR GO TO [WWW.THINBIT.COM/SWISS](http://WWW.THINBIT.COM/SWISS)



GROOVE  
'N TURN®

WHAT CAN YOU DO WITH A SINGLE INSERT?

# DESIGN-A-GROOVE®

**We Can Do That!®**

**GROOVING**

**TURNING**

**FORM TOOLS**

**PARTING**

**BORING**

**THREADING**

**TOOLHOLDERS**



PG  
8-1

**FACE GROOVING**

THINBIT® is an industry leader at designing and manufacturing custom tooling.

e-mail your application to [quotes@thinbit.com](mailto:quotes@thinbit.com)



PG  
8-7



**FORM-A-GROOVE®** tools consist of simple grooves or complex combinations of grooves, arcs, angles, convex and concave radii, as well as special thread forms.



PG  
8-7



**MADE IN<sup>®</sup>  
THE USA?  
DAMN RIGHT.**

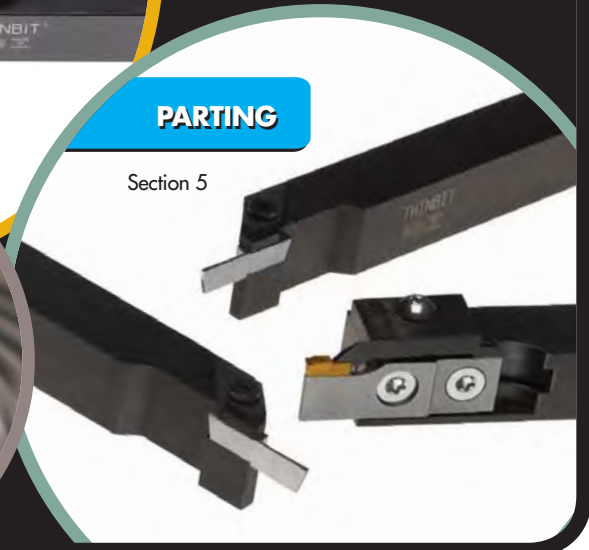
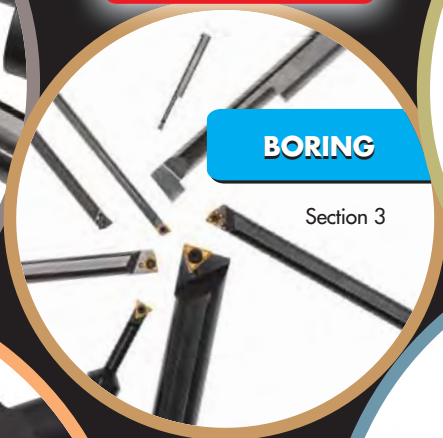

US Patent Nos.: 6,688,816; 6,824,333; 5,638,728; 6,722,825; 6,974,282

Distributed by:

**THINBIT<sup>®</sup>.COM**

Kaiser Tool Company, Inc. | 3620 Centennial Dr., Ft. Wayne, IN 46808  
888-THINBIT | 888-THINFAX | thinbit@kaisertool.com



## 2018 THINBIT® Catalog Index

### Introduction – Information and General Information

- Pg. 5 General Information: Hours; Shipments; Terms; Pricing; Returns; Credit
- Pg. 6 Standard Product Index sorted by Product Code (Laser Marked Codes on most Tools)
- Pg. 7 Discontinued Standard Product Index

### Section 1 – Grooving (Inserts and Solid Carbide Tools)

- Pg. 1-1 Product Selection Guide for External and Internal Grooving Tools (Pictures and Descriptions)
- Pg. 1-2 Orientation guide for External and Internal Grooving Tools
- Pg. 1-3 Tools for Internal Diameters of .125" and Larger (MICROBIT® Solid Carbide Tooling)
- Pg. 1-4 Order Instructions for MICROBIT® Solid Carbide Tooling
- Pg. 1-5 Tools for Internal Diameters of .325" and Larger (MINI-GROOVE 'N TURN®)
- Pg. 1-6 Ordering Instructions for MINI-GROOVE 'N TURN® I.D. Grooving Tools
- Pg. 1-7 Tools for Internal Diameters of 1.000" and Larger (DEEPGROOVE®)
- Pg. 1-8 Ordering Instructions for DEEPGROOVE® I.D. Grooving Tools
- Pg. 1-9 External and Internal Grooving Tools of 1.250" and Larger (GROOVE 'N TURN®)
- Pg. 1-10 Ordering Instructions for GROOVE 'N TURN® O.D & I.D. Grooving Tools
- Pg. 1-11 External and Internal Grooving Tools of 1.250" and Larger for Static O-Rings (GROOVE 'N TURN®)
- Pg. 1-12 Ordering Instructions for GROOVE 'N TURN® Static O-Ring Inserts
- Pg. 1-13 External Grooving/Parting Packages (Inserts are on Pg. 6-1) with Depth of Cut up to 1" (DEEPGROOVE®)
- Pg. 1-14 Ordering Instructions for DEEPGROOVE® O.D. Grooving and Parting Tools

### Section 2 – Face Grooving (Inserts and Solid Carbide Tools)

- Pg. 2-1 Product Selection Guide for Face Grooving Tools (Pictures and Descriptions)
- Pg. 2-2 Orientation Guide for External and Internal Face Grooving Tools
- Pg. 2-3 Internal Diameters of .125" and Larger (MICROBIT® Solid Carbide Tools)
- Pg. 2-4 Ordering Instructions for MICROBIT® Face Grooving Solid Carbide Tools
- Pg. 2-5 Internal Diameters of .415" and Larger (MINI-GROOVE 'N TURN®)
- Pg. 2-6 Ordering Instructions for MINI-GROOVE 'N TURN® Face Grooving Solid Carbide Tools
- Pg. 2-7 Internal Diameters of 1.574" and larger (DEEPGROOVE®)
- Pg. 2-8 Ordering Instructions for DEEPGROOVE® I.D. Face Grooving Tools
- Pg. 2-9 Face Grooving Inserts for .300", .750", 1.250" and 3" Major Diameters (GROOVE 'N TURN®)
- Pg. 2-10 Ordering Instructions for GROOVE 'N TURN® Face Grooving Tools
- Pg. 2-11 Dovetail O-Rings .300", .750", 1.250", 3" (Groove 'N Turn®)
- Pg. 2-12 Ordering Instructions for GROOVE 'N TURN® Dovetail O-Ring Face Grooving Inserts
- Pg. 2-13 Static O-Rings with Groove Widths .086", .103", .122", 125", .138" (GROOVE 'N Turn®)
- Pg. 2-14 Ordering Instructions for GROOVE 'N TURN® Static O-Ring Face Grooving Inserts
- Pg. 2-15 External Face Grooving Packages (Inserts are on Pg 6-1) with Depth of Cut up to 1" (DEEPGROOVE®)
- Pg. 2-16 Ordering Instructions for DEEPGROOVE® Face Grooving Tools

### Section 3 – Boring, Profiling & Turning Tools (Inserts, Bars and Shanks)

- Pg. 3-1 Product selection guide for Boring, Profiling & Turning Tools (Pictures and Descriptions)
- Pg. 3-2 Orientation Guide for Boring, Profiling & Turning
- Pg. 3-3 Boring Diameters .073" and larger (MICROBIT® Solid Carbide Tools)
- Pg. 3-4 Ordering Instructions for MICROBIT® Boring Tools
- Pg. 3-5 Profiling & Reverse Profiling Diameters .125" and larger (MICROBIT® Solid Carbide Tools)
- Pg. 3-7 Boring Diameters .210" and larger (MINI-BORE® Trigon®) (MBE Series)
- Pg. 3-9 Boring Diameters .330" and larger (MINI-BORE® Trigon®) (MBF Series)
- Pg. 3-10 Boring Diameters .410" and larger (MINI-BORE® Trigon®) (MBG Series)
- Pg. 3-11 Boring Diameters .165" and larger (MINI-BORE®) (MBZ Series)
- Pg. 3-12 Ordering Instructions for MINI-BORE® CD style MBZ Series Boring Bars and Inserts
- Pg. 3-13 Boring Diameters .180" and larger (MINI-BORE®) (MBA Series boring bars)
- Pg. 3-14 Boring Diameters .180" and larger (MINI-BORE®) (MBA Series boring inserts)
- Pg. 3-15 Boring Diameters .300" and larger (MINI-BORE®) (MBB Series boring bars)
- Pg. 3-16 Boring Diameters .300" and larger (MINI-BORE®) (MBB Series boring inserts)
- Pg. 3-17 Boring Diameters .430" and larger (MINI-BORE®) (MBC Series boring bars)
- Pg. 3-18 Boring Diameters .430" and larger (MINI-BORE®) (MBC Series boring inserts)

### Section 4 – Threading and Chamfering (Inserts and Solid Carbide Tools)

- Pg. 4-1 Product Selection Guide for Threading and Chamfering Tools (Pictures and Descriptions)
- Pg. 4-2 Orientation Guide for Threading and Chamfering Tools
- Pg. 4-3 Internal Threading for Diameters .077" and Larger (MICROBIT® Solid Carbide Tools)
- Pg. 4-4 Ordering Instructions for I.D. Threading Tools
- Pg. 4-5 Internal ACME Threading for Diameters .187" and Larger (MICROBIT® Solid Carbide Tools)
- Pg. 4-6 Ordering Instructions for MICROBIT® I.D. ACME Threading Tools
- Pg. 4-7 Internal Threading for Diameters .325" and Larger (Mini-Groove 'N Turn®)
- Pg. 4-8 Ordering Instructions for MINI GROOVE 'N TURN® I.D. Threading Tools
- Pg. 4-9 External Threading within .065" of a Shoulder (Groove 'N Turn®)
- Pg. 4-10 Ordering Instructions for GROOVE 'N TURN® Threading Inserts

Pg. 4-11 External Threading and Internal ACME Threading with 1.250" Minimum Bore (Groove 'N Turn®)

Pg. 4-12 Ordering Instructions for GROOVE 'N TURN® ACME Threading Inserts

Pg. 4-13 External and Internal Chamfering for Internal Diameters of 1.250" and Larger (Groove 'N Turn®)

Pg. 4-14 Ordering Instructions for GROOVE 'N TURN® Chamfering Inserts

#### **Section 5 – Parting (Inserts)**

Pg. 5-1 Pictures and Descriptions of Parting Tools

Pg. 5-2 Orientation Guide for Parting Tools

Pg. 5-3 Parting Inserts up to 1" Diameter (GROOVE 'N TURN®)

Pg. 5-4 Ordering Instructions for GROOVE 'N TURN® Parting Inserts

#### **Section 6 – DEEPGROOVE® OD and ID Face Grooving Inserts**

Pg. 6-1 2,3,4,5 and 6MM Inserts for Face Grooving (DEEPGROOVE®)

Pg. 6-2 Ordering Instructions for DEEPGROOVE® Face Grooving Inserts

#### **Section 7 – Toolholders (additional DEEPGROOVE® Toolholders on pg. 1-8, 1-14,2-8, 2-16)**

Pg. 7-1 Product Selection Guide for Toolholders

Pg. 7-2 Round and Square Adapters

Pg. 7-3 Straight GROOVE 'N TURN® Toolholders

Pg. 7-4 90° GROOVE 'N TURN® Toolholders

Pg. 7-5 Swiss Screw Machine GROOVE 'N TURN® Toolholders

Pg. 7-6 Swiss Screw Machine GROOVE 'N TURN® Face Grooving Toolholders

Pg. 7-7 Round Reversible GROOVE 'N TURN® Toolholders

Pg. 7-8 Round Internal GROOVE 'N TURN® Toolholders

Pg. 7-9 Multi-Insert Square FORM-A-GROOVE® Toolholders

Pg. 7-10 Multi-Insert Round FORM-A-GROOVE® Toolholders

Pg. 7-11 45° and 30°/60° GROOVE 'N TURN® Toolholders

Pg. 7-12 Ordering Instructions for GROOVE 'N TURN® 45° and 30°/60° Toolholders

Pg. 7-13 Round DEEPGROOVE® Shanks with External Heads

Pg. 7-14 Square DEEPGROOVE® Shanks with Internal Face Grooving Heads

#### **Section 8 – Custom Inserts and Tools**

Pg. 8-1 Custom DESIGN-A-GROOVE® Insert Instructions and Ordering Process

Pg. 8-2 Custom Face Grooving Tooling Specifications

Pg. 8-3 Definition of Insert Modifications

Pg. 8-4 Insert Modification Specification Sheet

Pg. 8-5 Custom Threading Tooling Specifications

Pg. 8-6 Solid Carbide MICROBIT® Custom Blanks

Pg. 8-7 Custom FORM-A-GROOVE® Multi Groove Tools

#### **Section 9 – Technical Information**

Pg. 9-1 General Information

Pg. 9-2 Page Omitted

Pg. 9-3 External Application Reference

Pg. 9-4 Internal application Reference

Pg. 9-5 Insert Grade Information

Pg. 9-6 Insert Coating Information

Pg. 9-7 Troubleshooting Information

Pg. 9-8 General Toolholder Information

Pg. 9-9 Grooving - Geometry and Set-Up Information

Pg. 9-10 Grooving - Speeds and Feeds

Pg. 9-11 Face Grooving - Geometry and Set-Up Information

Pg. 9-12 Face Grooving - Speeds and Feeds

Pg. 9-13 Boring & Turning – Geometry and Set-Up Information

Pg. 9-14 Boring & Turning – Speeds and Feeds for MBE, MBF and MBG Boring Bars

Pg. 9-15 Boring & Turning – Speeds and Feeds for MBZ, MBA, MBB and MBC Boring Bars

Pg. 9-16 Boring & Turning – Speeds and Feeds for MBA, MBB and MBC PCD and CBN Tipped Inserts

Pg. 9-17 Threading – Geometry and Set-Up Information

Pg. 9-18 Threading – Speeds and Feeds

Pg. 9-19 Parting – Geometry and Set-Up Information

Pg. 9-20 Parting – Speeds and Feeds

#### **Section 10 - LITTLEBIT® Inserts and Toolholders**

Pg. 10-1 O.D./I.D. Grooving Inserts

Pg. 10-2 Parting Inserts

Pg. 10-3 O.D./I.D. Threading Inserts

Pg. 10-4 Ground Blanks and Grooving Insert Sets

Pg. 10-5 Flushtop & Hardinge Toolholders

Pg. 10-6 Swiss Screw Machine and Swiss Face Toolholders

Pg. 10-7 Reversible Toolholders, Straight and 90°