

# Storing, Handling, and Cutting Steel Panels

## Storing

- Specifically check your quantities, colors, and lengths
- All materials should be used as soon as possible
- Steel bundles should be stored indoors with enough of a slope to allow any moisture from condensation to drain out of the bundle
- Bare galvanized panels should be installed immediately and not be stored outside
- Condensation or rain water trapped on bare galvanized panels can form a wet storage stain, also known as white rust.

## Handling

- Do not slide steel panels across each other.
- Do not slide the panels from end to end in the bundle. Remove each sheet one at a time from the side of the bundle from the side of the bundle from the underlap side of the panel.
- To properly lift a panel from the bundle place hands underneath the under lap side of the panel and lift up and away from the bundle.
- Lifting steel onto roof or building grab the panel in the flat of the panel and not in the rib.
- Bending steel is best done with a hand seamer or a brake press.

## Cutting Panels

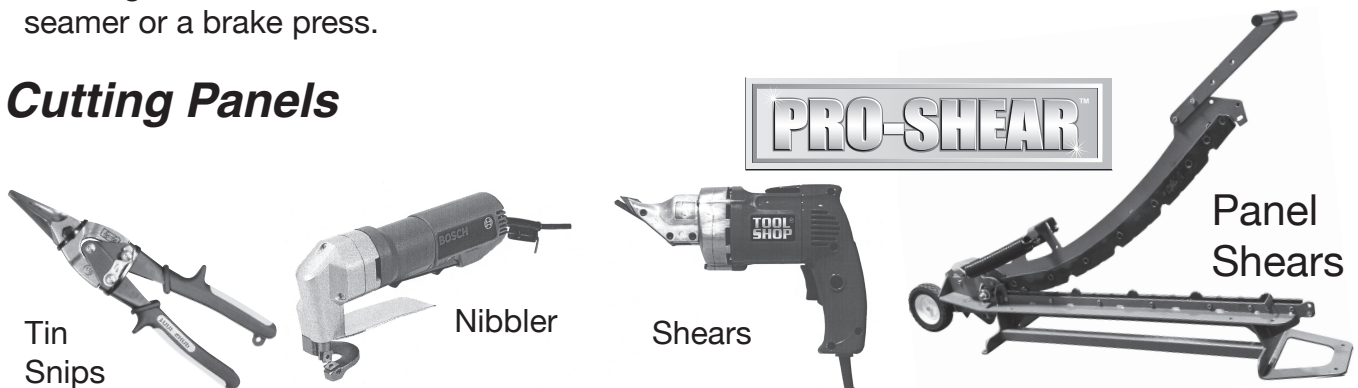

Cutting steel is best done with a shears, tin snips, nibblers, or panel shears. Cut edge does not require paint touch up.

**Do not use a circular saw or grinder to cut steel panels.**

## Steel Panel Installation:

### Proper lapping of Steel



Proper lapping of steel panel is very important in the panel's ability to prevent leaking.

The anti-syphon drain channel must be clear of debris and obstructions for the panel's ability to minimize the potential of capillary action of water from getting under the steel panel.

# Fastener Installation:

## Proper Fastener Tightness



Fastener tightness is critical in the longevity of the fastener's ability to help prevent leaks and structural load carrying capacity. Over-torquing of screws will reduce the screw's withdrawal capacity, regardless of the construction materials involved. Under-torquing of screws will increase the potential of roof leaks.

Fastener location is critical for installers to minimize the potential of oil canning, dimples, and other appearance related issues.

**Note:** Both professional and first time installers have fewer problems with oil canning, dimples, and other appearance related fastener seating problems if they install them on top of the rib.

### Drill/Drivers:

The correct choice of the drill/driver is essential to ensure the fastener can perform properly. A battery powered or corded drill/driver with the proper rpm speed is recommended.

Application	RPM Speed
Panels to wood	2,500
Panels to metal - self-drill	2,000
Panels to metal - self-tap	1,000

The use of higher drill/driver for wood applications can result in overtightening or stripping out the fastener. Attempting to install self-drill fasteners into steel substrates with faster drills/drivers can result in fastener failure due to the points burning up.

Impact drivers are **NOT** recommended for fastening panels. With the higher torque produced by these drivers, fasteners can be easily over driven to the point of the washer being over tightened or the fastener breaking. Additionally, the impacting action can cause excessive paint damage to the fastener heads and thread strip out.

### Fastener Specifications:

Roof: Screws can be installed on top of the rib or in the flat surface of the panel between the ribs.

Wall: Screws can be installed on top of the rib or in the flat surface between ribs.

### Screwing of Steel Panels

- Roof Sheets -Use 2" Woodgrip screws on rib top or 1" screws in the flat.
- Peak & Eave of roof sheets -Use 1" Woodgrip screws installed in the flat surface
- Wall sheets -Use 1" Woodgrip screws installed in the flat surface

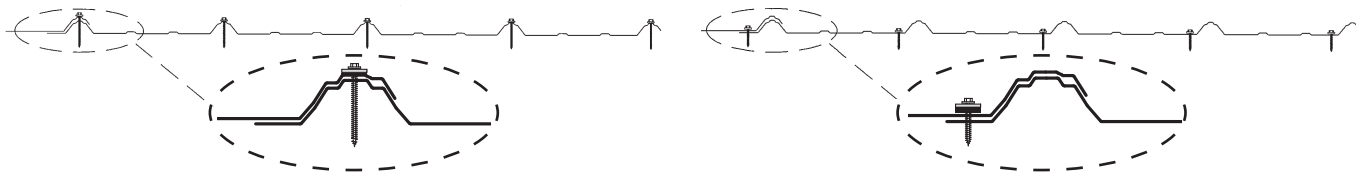

**Note:** Screw lengths may need to be adjusted.

**Note:** If an alternative fastening method is used, then the material list may have to be altered for proper fastener lengths.

# Hanging Sidewall Steel

**Note:** Optional Bottom Trim May be installed at this time.

**Note:** Positioning of the first panel is critical. The first panel installed establishes the alignment and layout of the entire wall. It is very important that the first panel is accurately positioned and squared before fastening it in place.

**Tip:** When laying out the steel panel have the overlap side of the panel away from the main line of sight.

**Tip:** You may want to start at a corner away from the prevailing wind.

Cut the first rib off leaving  $\frac{1}{4}$ " of rib on the first sheet of side steel (Fig. 1). Position the first panel so it is square in the corner. Make sure the first sheet of sidewall steel is level and the top of the sheet is even with the top edge of the edge purlin. This should leave approximately 3" of grade board exposed at the bottom (Fig.2).

Using 1" screws, secure the top and bottom of the steel panel at the lap next to the rib, to assure proper lap and seating of the steel panel. Securing the panel in this manner will assure all laps to be seated and will not allow the steel to grow or stretch as you are running it. Once all the panels are in place and secure only at the lap, snap a chalk line at each mid-girt location and finish fastening the wall with 2" screws on top of the rib. At the top and bottom of the panels use  $1\frac{1}{2}$ " fasteners on both sides of each rib, for the length of the building.

**Note:** Do not put fasteners on the rib at the top and bottom of the panel. Doing this may crush the end of the panel.

# Hanging Endwall Steel

Endwall panels are fastened in the same manner as the sidewall panels. The only difference is the gable sheets are always started from the middle of the building and run towards the corners. The panels should be measured and the gable angle cut off of the top before installing the panels.

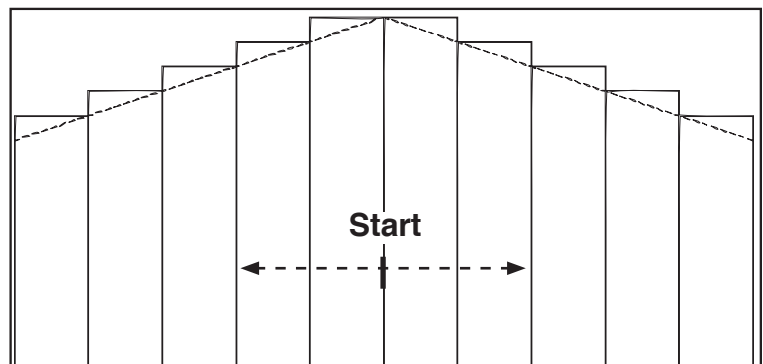
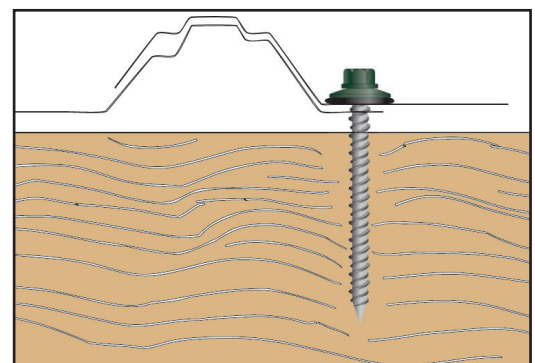
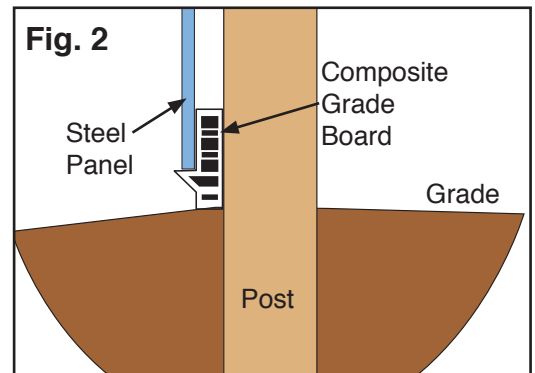
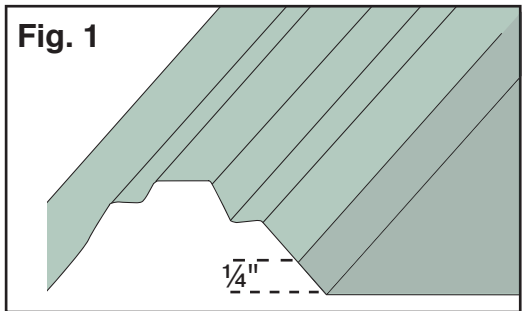
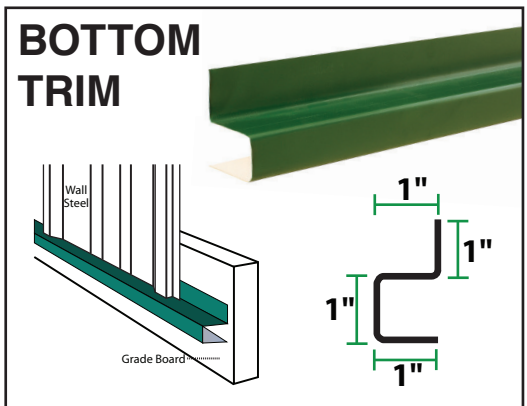



# Installing Residential Roof Steel

The first panel on the roof should be  $\frac{1}{4}$ " in from the rake end and can overhang the roof edge a minimum of  $\frac{3}{4}$ " or a maximum of 3". This method is used as long as the roof plane is square.

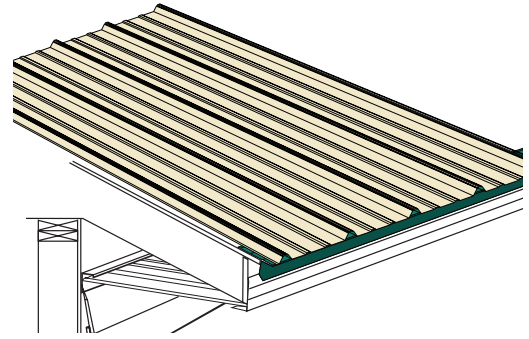

The panels will run square when placed on the roof. If the roof plane is out of square, compensation will need to be made in the placement of the steel. Most builders place the panels true to the eaves and not true to the rake to compensate for being out of square.

Running true to the rake means compensation for square has to be made at the eaves line. This is a noticeable step in the panel from sheet to sheet. This usually looks like the panel at the eaves line is  $\frac{1}{4}$ " longer or shorter than the previous panel. It also makes the panel look like it has not been cut square at the end.

Measure the diagonals on the roof. If the measurements of "A" and "B" are the same, then your roof is square. If the measurements are not the same, then adjustments may need to be made to run your steel correctly.

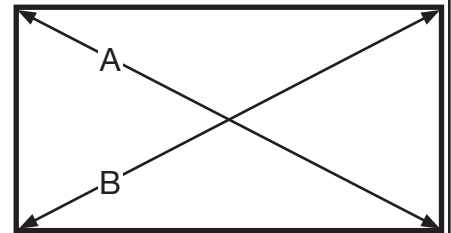

For Pro-Rib® and Premium Pro-Rib® panels, the fasteners at the top and the bottom of the panel should be placed in the flat next to the rib. The first panel should be placed so the overlap side of the panel is towards the rake end of the roof.

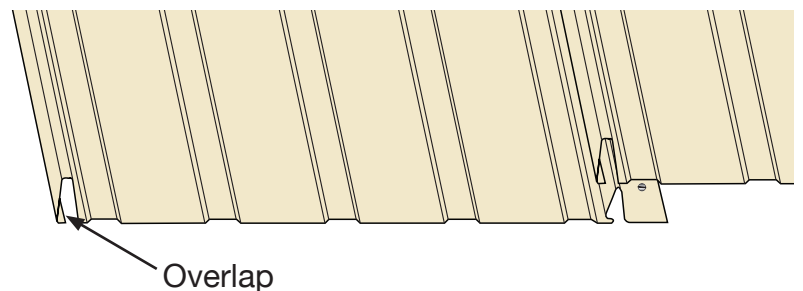
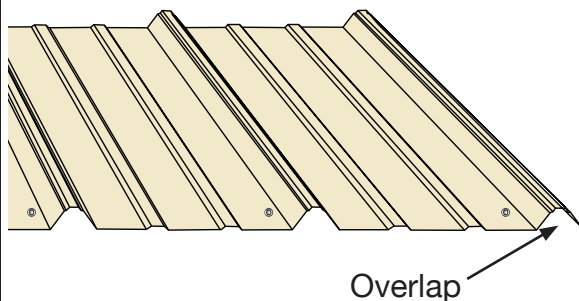
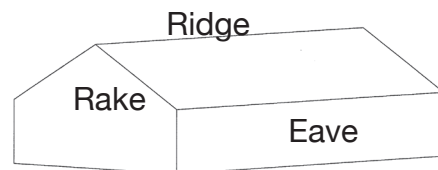

# Installing Residential Roof Steel

## Where does my second panel get placed?

Whether you are using exposed or hidden fastener panels, the next panel should overlap the previous panel and be flush at the eaves end of the panel.

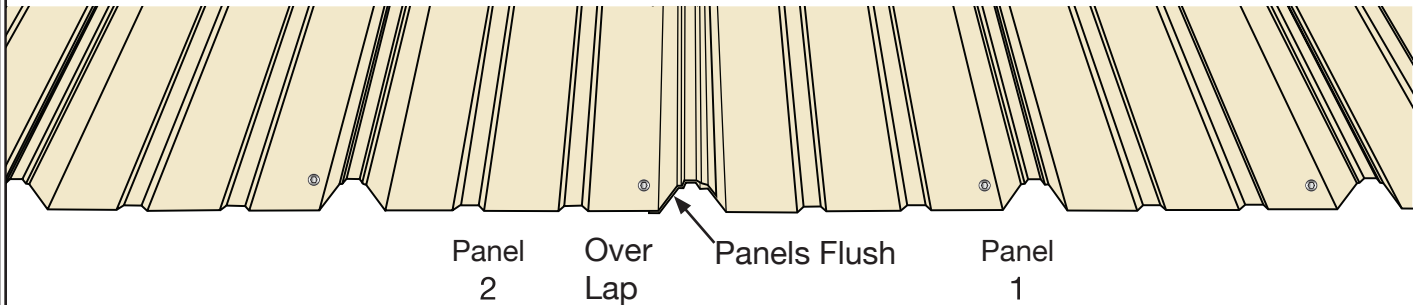

## Where do fasteners go on the next panel installed?

On exposed fastener panels, the overlap should always be fastened top to bottom to ensure a good lap of the panels. Properly seated lap prevents any leakage from capillary action.

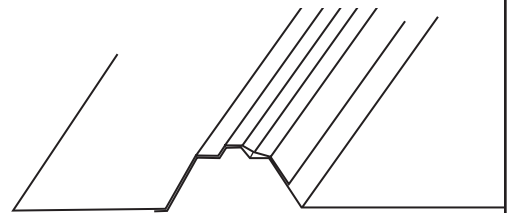

## What if my panels are not lapped correct?

A panel that is overlapped too much will cast shadow lines that will be noticed to the point where you can see every panel lap on the roof. A panel that is not lapped enough could show light through the lap. Both cases could result in a leak or aesthetic appearance problems.

## What about the Hidden Fastener panel lap?

Install your first panel square on your roof. Then, while making sure panels are flush at the eaves edge, lightly compress and snap panels together at the seam. Snap the panels from eaves to ridge. Fasteners should not be spaced more than 36" on center in the fastening flange. The eaves also need to be fastened between the ribs. Three common methods are:

- 1) 2 residential roofing screws evenly spaced between the Ribs at the Eaves.
- 2) Steel Roof Edge fastened 1' on center with a 1" pancake head screw and tape mastic applied to the roof edge.
- 3) Notch and cut out both the overlap and underlap of the hidden fastener panel  $\frac{3}{4}$ " from the eaves edge. Bend that eaves edge of the panel back on the underside and hook it onto the steel roof edge. Fasten with 1" pancake head screws 12" on center.

