



INSTRUMENTS

SDM-3R Docking Station Standalone Configuration Operator's Manual

Part Number: 71-0487

Revision: P4

Released: 4/9/20

Warranty

RKI Instruments, Inc. warrants gas alarm equipment sold by us to be free from defects in materials and workmanship, and performance for a period of one year from date of shipment from RKI Instruments, Inc. Any parts found defective within that period will be repaired or replaced, at our option, free of charge. This warranty does not apply to those items which by their nature are subject to deterioration or consumption in normal service, and which must be cleaned, repaired, or replaced on a routine basis. Examples of such items are:

Absorbent cartridges	Batteries
Pump diaphragms and valves	Filter elements
Fuses	

Warranty is voided by abuse including mechanical damage, alteration, rough handling, or repairs procedures not in accordance with the instruction manual. This warranty indicates the full extent of our liability, and we are not responsible for removal or replacement costs, local repair costs, transportation costs, or contingent expenses incurred without our prior approval.

THIS WARRANTY IS EXPRESSLY IN LIEU OF ANY AND ALL OTHER WARRANTIES AND REPRESENTATIONS, EXPRESSED OR IMPLIED, AND ALL OTHER OBLIGATIONS OR LIABILITIES ON THE PART OF RKI INSTRUMENTS, INC. INCLUDING BUT NOT LIMITED TO THE WARRANTY OF MERCHANTABILITY OR FITNESS FOR A PARTICULAR PURPOSE. IN NO EVENT SHALL RKI INSTRUMENTS, INC. BE LIABLE FOR INDIRECT, INCIDENTAL, OR CONSEQUENTIAL LOSS OR DAMAGE OF ANY KIND CONNECTED WITH THE USE OF ITS PRODUCTS OR FAILURE OF ITS PRODUCTS TO FUNCTION OR OPERATE PROPERLY.

This warranty covers instruments and parts sold to users only by authorized distributors, dealers, and representatives as appointed by RKI Instruments, Inc.

We do not assume indemnification for any accident or damage caused by the operation of this gas monitor and our warranty is limited to replacement of parts or our complete goods.

Table of Contents

Chapter 1: Introduction	6
Overview	6
About the SDM-3R	6
System Requirements	7
About This Manual	7
Cautions & Safety Information	8
Specifications	8
Building a System	9
Chapter 2: Description	10
Overview	10
SDM-3R	10
<i>Instrument Cradle</i>	10
<i>Control Buttons and LEDs</i>	11
<i>Cylinder Connections (Side Panels)</i>	12
<i>Power and Network Connections (Back Panel)</i>	13
Standard Accessories	14
<i>Air Filter and Exhaust Tubing</i>	14
<i>Calibration Tubing</i>	14
<i>Single-Station AC Adapter</i>	15
<i>USB Cable</i>	15
<i>Ethernet Cable</i>	15
<i>USB Drive</i>	15
Optional Accessories	16
<i>Connection Brackets</i>	16
<i>Wall Mounting Brackets</i>	16
<i>Cylinder Holders</i>	16
<i>Demand Flow Regulator</i>	16
<i>Calibration Cylinder</i>	16
<i>CO₂ Scrubber</i>	16
Chapter 3: Mechanical Setup of SDM-3R	17
Overview	17
Connecting Multiple SDM-3Rs Together, Optional	17
Hardware Assembly	19

Wall Mounting the SDM-3R, Optional	19
Installing the Cylinder Holder, Optional	22
Connecting Calibration Gas	23
Chapter 4: Parameter Setup in SDM-3R's Config Menu	26
Bump Test Parameters	26
Calibration Parameters	31
Gas Cylinder Assignments	34
Date and Time	37
Password	39
Setting Up LAN Connectivity	42
Chapter 5: Detailed Parameter and LAN Setup in PC Program	42
Installing the SDM-3R PC Program	42
Making Detailed Parameter Changes in the SDM Window	43
Setting up LAN Connectivity	47
Chapter 6: Operation	55
Overview	55
Automatically Initiated Tests	55
Turning on an SDM-3R System	55
Bump Testing	56
Calibration	60
Alarm Check	63
Downloading/Copying Data to a USB Drive	63
<i>Downloading GX-3R (Pro) Logger Data</i>	<i>63</i>
<i>Copying Bump Test, Calibration, and Alarm Check Records</i>	<i>64</i>
Chapter 7: Maintenance	65
Troubleshooting	65
Charging a GX-3R (Pro)	66
Chapter 8: Importing Data Into the PC Program	68
Overview	68
Importing from a USB Drive	68
Importing Using the LAN Network	71
Viewing Imported Data	73
Exiting the Program	73
Chapter 9: Spare Parts List	74

CAUTION: *Read and understand this manual before using the SDM-3R. Also read and understand the GX-3R (Pro) Operator's Manual.*

Chapter 1: Introduction

Overview

This chapter briefly describes the SDM-3R Docking Station and the SDM-3R Docking Station PC Controller Program. This chapter also describes the *SDM-3R Docking Station Standalone Configuration Operator's Manual* (this document). Table 1 at the end of this chapter lists the SDM-3R's specifications.

About the SDM-3R

The SDM-3R docking station is an advanced, reliable system that can charge, bump test, calibrate, alarm check, and provide test records for up to 10 GX-3R (Pro) portable gas monitors at once. It is designed for desktop or benchtop use (standalone functionality) or to be connected directly to a computer (PC controlled functionality).

When used in the standalone configuration, test records are stored in the SDM-3R's memory. The records can be saved to a USB drive and imported into the PC Program.

If you are using the PC Program while operating in the PC controlled configuration, you may retrieve instrument data, bump test, calibrate, and alarm check instruments. Instrument information and data for each instrument can be viewed directly using the PC Program and can be printed from the PC Program. For instructions to use the SDM-3R in the PC Controlled Configuration, see the *SDM-3R Docking Station PC Controlled Configuration Operator's Manual*.

The purpose of this manual is to explain how to set up and use the SDM-3R in Standalone configuration. It also explains how to use the sections of the PC Program associated with Standalone use. You will learn how to:

- install and launch the PC Program
- prepare the SDM-3R for use
- perform a bump test
- perform a calibration
- perform an alarm check
- download instrument data to the USB drive
- import instrument data, bump test, calibration, and alarm check records to the PC Program's database
- use the SDM-3R to charge a GX-3R (Pro)

CAUTION: *The GX-3R (Pro) detects oxygen deficiency and elevated levels of oxygen, combustible gases, carbon monoxide, and hydrogen sulfide, all of which can be dangerous or life threatening. When using the GX-3R (Pro), you must follow the instructions and warnings in the GX-3R (Pro) Operator's Manual to assure proper and safe operation of the instrument and to minimize the risk of personal injury.*

CAUTION: *The operator of this instrument is advised that if the equipment is used in a manner not specified in this manual, the protection provided by the equipment may be impaired.*

System Requirements

To use the SDM-3R Docking Station PC Controller Program, your personal computer must meet the following requirements:

- **Operating Systems:** Windows[®] 7, Windows[®] 8, Windows[®] 10.
- **Processor:** IBM[®] compatible PC running Pentium[®] 2 processor or equivalent minimum
- **Memory:** 32 MB RAM minimum
- **Hard Disk Space:** 32 MB minimum
- **Available USB Port**

About this Manual

The *SDM-3R Docking Station Standalone Configuration Operator's Manual* uses the following conventions for notes, cautions, and warnings.

NOTE: Describes additional or critical information.

CAUTION: *Describes potential damage to equipment.*

WARNING: *Describes potential danger that can result in injury or death.*

Cautions & Safety Information

- Use only polyurethane sample tubing with the SDM-3R. Consult RKI Instruments, Inc. for other materials.
- Do not subject the SDM-3R to infrared or intense light. This may cause communication errors.
- Do not expose the SDM-3R to water.
- Do not subject the SDM-3R to any hard impact.

Specifications

Table 1: Specifications

Input Power	5.99 VDC
Environmental Conditions	<ul style="list-style-type: none"> • For Indoor Use Only • 0° C to 40° C, below 95% Relative Humidity, Non-Condensing
Applicable Instrument	<ul style="list-style-type: none"> • GX-3R • GX-3R Pro
Memory Capacity	150 KB
Record Size	<ul style="list-style-type: none"> • Bump test: 698 bytes • Calibration: 749 bytes • Alarm check: 320 bytes
Maximum Number of Records Saved	<ul style="list-style-type: none"> • Bump test: 214 OR <ul style="list-style-type: none"> • Calibration: 200 OR <ul style="list-style-type: none"> • Alarm check: 468
Number of Calibration Gas Cylinders	4 if you have 3 solenoid valves installed
Standard Accessories	<ul style="list-style-type: none"> • Instruction Manual* • SDM-3R Docking Station PC Controller Software* • Inlet Air Filter • 10-Foot Long Exhaust Tube • 3-Foot Long Calibration Tube • Single-Station AC Adapter • USB Cable, Type A to Type B • Ethernet Cable • USB Drive
Available Accessories	<ul style="list-style-type: none"> • Connection Brackets • Wall Mounting Brackets • Cylinder Holder • Demand Flow Regulator • Calibration Cylinder • CO₂ Scrubber

* Not sent with SDM-3R. Download from www.rkiinstruments.com/sdm3r.

Building a System

Solenoid Valves

The SDM-3R is sold with 1, 2, or 3 solenoid valves.

1 Solenoid Valve (1XX Versions): For instruments that will only use 1 calibration cylinder.

- 4-gas (LEL/O₂/H₂S/CO) calibrated with 1 4-gas cylinder
- 5-gas (LEL/O₂/H₂S/CO/SO₂) calibrated with 1 5-gas cylinder

2 Solenoid Valves (2XX Versions): For instruments that will use 2 calibration cylinders.

- 5-gas (LEL/O₂/H₂S/CO/SO₂) calibrated with 1 4-gas cylinder and 1 SO₂ cylinder

3 Solenoid Valves (3XX Versions): For instruments that will use 2 calibration cylinders.

- 5-gas (LEL/O₂/H₂S/CO/CO₂) calibrated with 1 4-gas cylinder, 1 N₂ cylinder, and 1 CO₂ cylinder

Bundles

Various accessories are included with the SDM-3R depending on the bundle. See the table below for what's included with each basic bundle. Other bundles are available that include different calibration gas cylinders than the 4-gas mix included in the 81-SDM3R-X03 and 81-SDM3R-X04. The accessories are described in more detail in "Chapter 2: Description" on page 10.

	81-SDM3RX01	81-SDM3RX02	81-SDM3RX03	81-SDM3RX04
Docking Station	X	X	X	X
Exhaust Tube, 10 ft.	X	X	X	X
Calibration Tubing, 3 ft.	X	X	X	X
USB Cable	X	X	X	X
Ethernet Cable, 5 ft.	X	X	X	X
Single-Station AC Adapter	X	X	X	X
USB Drive	X	X	X	X
Demand Flow Regulator		X	X	X
Calibration Cylinder Holder			X	X
58 Liter Aluminum 4-Gas Calibration Cylinder			X	
34 Liter 4-Gas Calibration Cylinder				X

Chapter 2: Description

Overview

This section describes the SDM-3R docking station's components, various accessories that may or may not be included depending on what bundle was ordered, and optional accessories that are not included in any bundles.

SDM-3R

Instrument Cradle

The instrument cradle is a recessed area in the middle of the SDM-3R that is designed to accept the GX-3R or the GX-3R Pro. The yellow lever in the cradle must be up for GX-3R operation and down for GX-3R Pro operation. Insert the GX-3R (Pro) in the instrument cradle with the display facing up before you perform a bump test, calibration, alarm check or charge a GX-3R (Pro). An infrared (IR) port at the rear of the cradle lines up with the GX-3R (Pro)'s IR port when it is inserted in the cradle and is used to communicate with the instrument. A charging jack engages with the GX-3R (Pro) when you close the instrument cover.

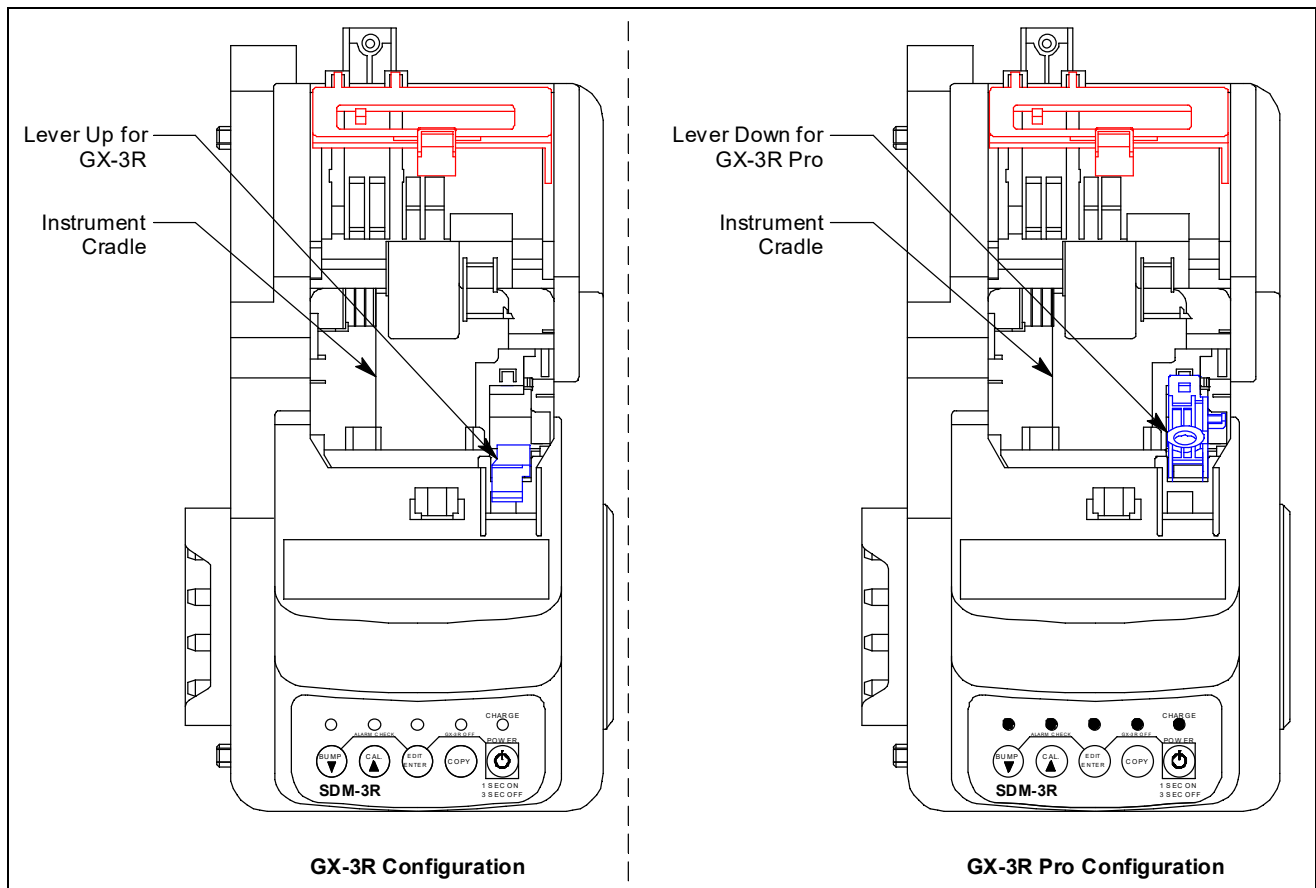

Figure 1: Instrument Cradle

Control Buttons and LEDs

Use the control buttons to initiate docking station function as outlined in the table below. The LEDs above the control buttons indicate the button function's status. The CHARGE LED functions as a pilot LED and a system failure LED.

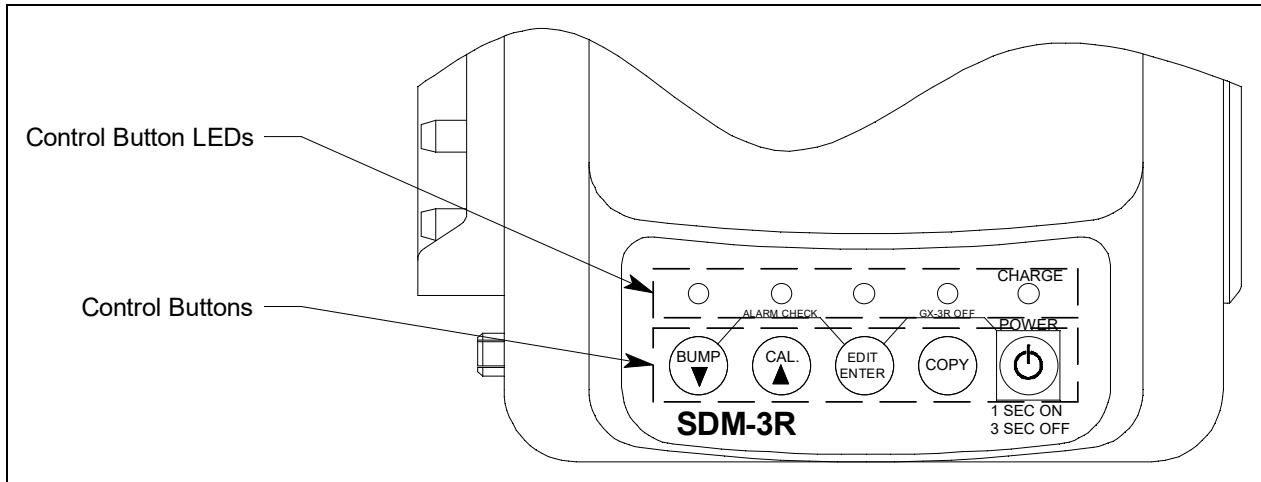

Figure 2: Control Buttons and LEDs

Control Button	Function	LED Meaning
BUMP ▼	<ul style="list-style-type: none"> Initiates/cancels a bump test Initiates/cancels an alarm check when used with EDIT ENTER 	<p><u>Flashing</u>: bump test in process</p> <p><u>Green</u>: bump test passed</p> <p><u>Red</u>: bump test failed</p>
CAL ▲	<ul style="list-style-type: none"> Initiates/cancels a calibration Clears SDM-3R memory when use with COPY 	<p><u>Flashing</u>: calibration in process</p> <p><u>Green</u>: calibration passed</p> <p><u>Red</u>: calibration failed</p>
EDIT ENTER	<ul style="list-style-type: none"> Enters Configuration Menu Initiates an alarm check when used with BUMP ▼ Turns off GX-3R (Pro) when used with POWER 	<p><u>Green</u>: alarm check passed</p> <p><u>Red</u>: alarm check failed</p>
COPY	<ul style="list-style-type: none"> Copies bump test, calibration, and alarm check records to a USB drive Clears SDM-3R memory when use with CAL ▲ 	<p><u>Off</u>: no records saved</p> <p><u>Green</u>: More than 20% of SDM-3R memory remains</p> <p><u>Orange</u>: Less than 20% of SDM-3R memory remains</p> <p><u>Red</u>: No memory available. Oldest records will be deleted as new records are created.</p>
POWER	<ul style="list-style-type: none"> Turns SDM-3R on/off Turns off GX-3R (Pro) when used with EDIT ENTER 	<p>(POWER button's LED is labelled "CHARGE")</p> <p><u>Solid green</u>: no GX-3R (Pro) installed or GX-3R (Pro) fully charged</p> <p><u>Flashing green</u>: GX-3R (Pro) IrDA communication established</p> <p><u>Flashing orange</u>: GX-3R (Pro) charging</p> <p><u>Solid red</u>: SDM-3R problem detected</p>

Cylinder Connections (Side Panels)

Four gas fittings are located on the left side of the SDM-3R. Three are for gas cylinders and one is for the particle filter or a zero air cylinder. The left to right order is: GAS 3, GAS 2, GAS 1, AIR. All four fittings accept 3/16 inch ID tubing.

The right side of the SDM-3R is shipped from the factory with a small panel attached to it with two screws. That panel should remain in place if the SDM-3R is being used alone or if it is the right-most station in a bank of connected stations. The panel needs to be removed in order to connect another SDM-3R to it. Beneath the panel are plugged fitting connections that mate to the stubs on the left side of another SDM-3R.

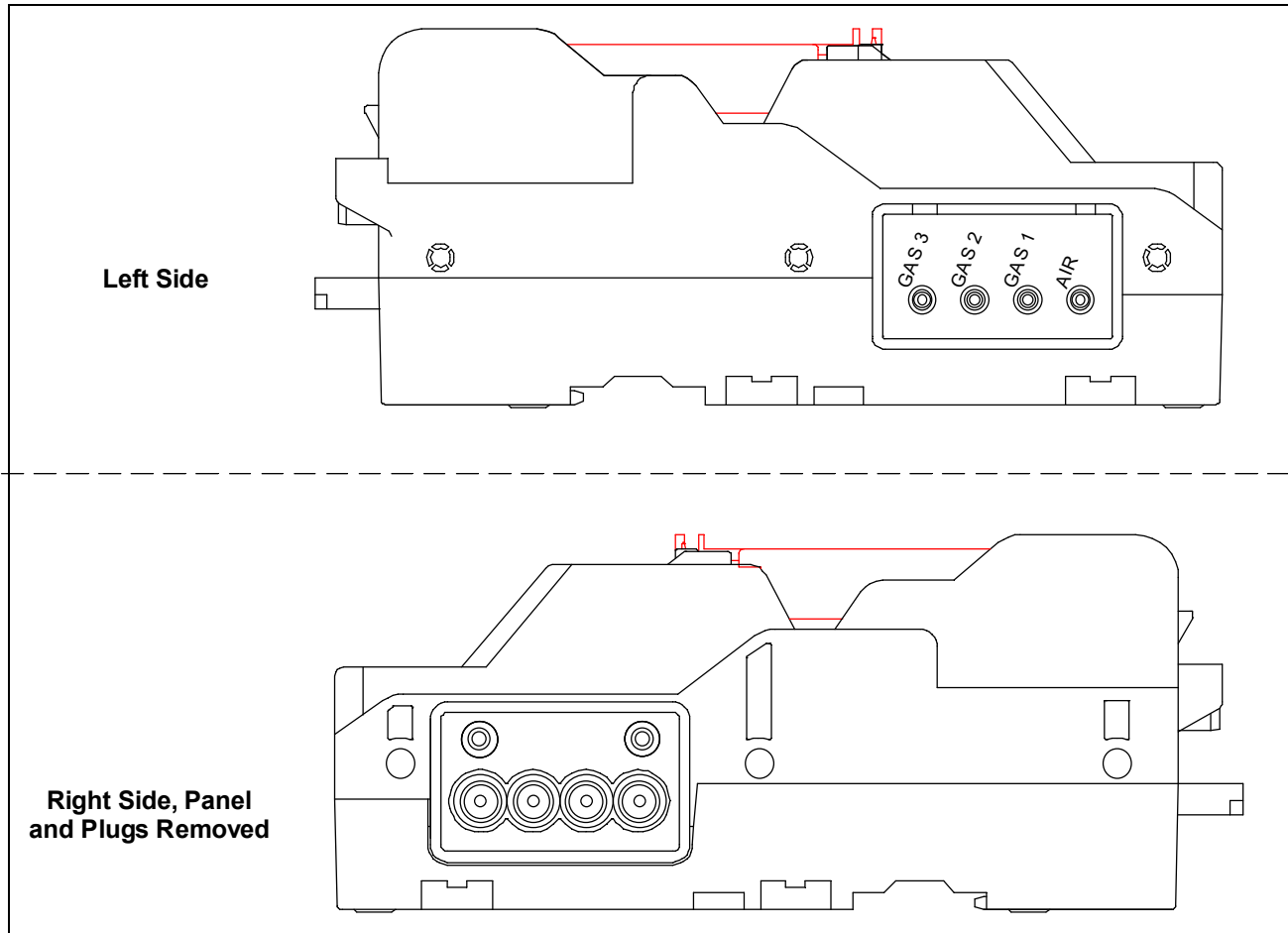

Figure 3: Cylinder Connection

Power and Network Connections (Back Panel)

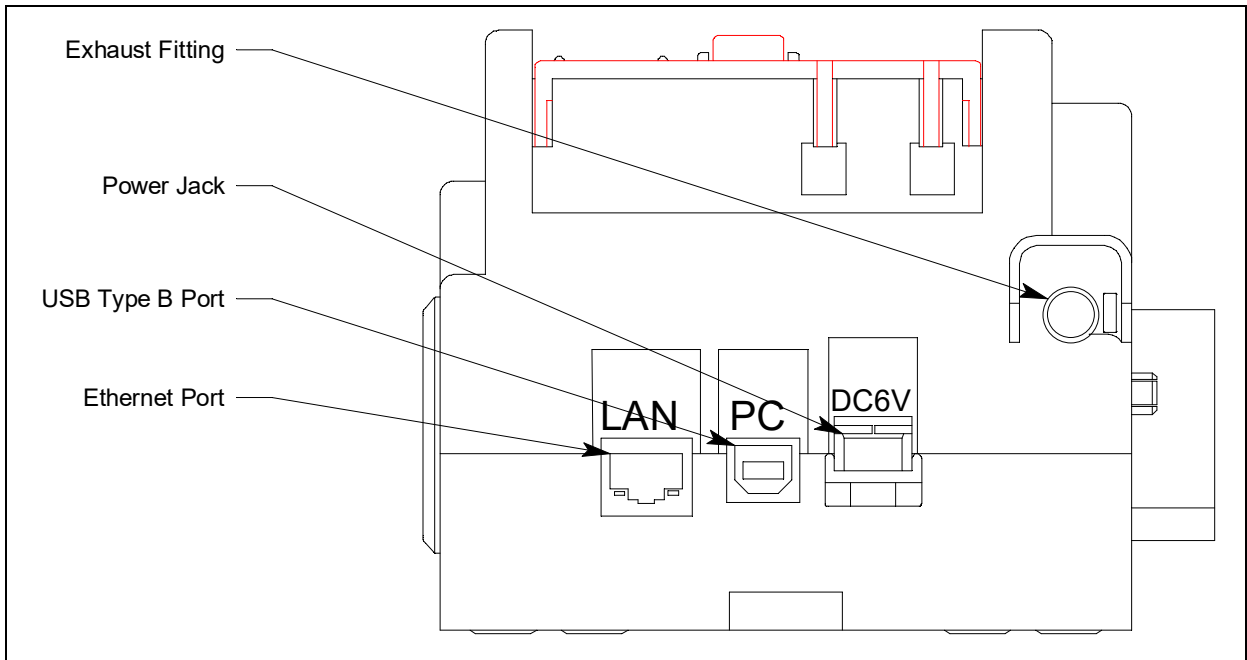

Figure 4: Back Panel

USB PC Connector

A type B USB connection allows for the SDM-3R to be connected to a PC using a Type A to Type B USB cable. Connection to a PC is necessary for setting up the LAN function and for using the SDM-3R in its PC controlled configuration. This manual explains how to set up the LAN function but does not cover PC controlled configuration.

LAN Connector

The LAN connector allows for the SDM-3R to be connected to a building's network using an Ethernet cable. This function allows for the SDM-3R's data to be downloaded to a computer connected to the same network.

Power Jack

The rectangular power jack is located on the far right side of the back panel. The SDM-3R uses the same charger as the GX-3R (Pro). The plug on the end of the AC adapter cable mates to the power jack. If desired, you can use the screw included with the AC adapter to ensure the cable does not disconnect from the SDM-3R.

Exhaust Fitting

An exhaust fitting is located on the right side of the back panel. It allows routing of the exhausted calibration gas to a convenient location. This fitting accepts 5/16 inch ID tubing. Even though the exhaust gas can be routed to an area to be safely dispersed, the docking station should still be installed in a well ventilated area.

Standard Accessories

Air Filter and Exhaust Tubing

A cylindrical particle filter with a short length of tubing is supplied with the SDM-3R for installation to the AIR fitting on the back panel. The filter keeps particulate contamination out of the docking station.

A 10 foot length of 5/16 inch ID polyurethane tubing is provided for connection to the exhaust fitting on the back panel to allow routing of the exhaust to a location such as an open window where the exhaust can disperse.

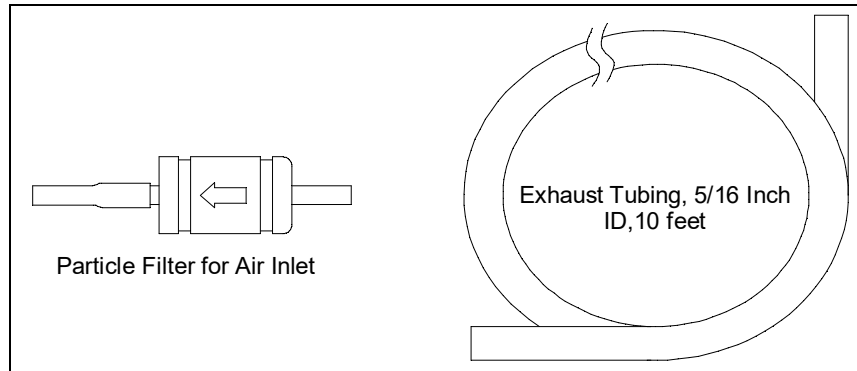

Figure 5: Air Filter & Exhaust Tubing

WARNING: *Do not use an exhaust tube that is longer than 15 feet. The increased flow restriction caused by a longer tube may affect gas response and cause inaccurate calibration and bump test results.*

Calibration Tubing

A 3-foot 3/16 inch ID tube is included for connecting a demand flow regulator to an SDM-3R gas inlet fitting.

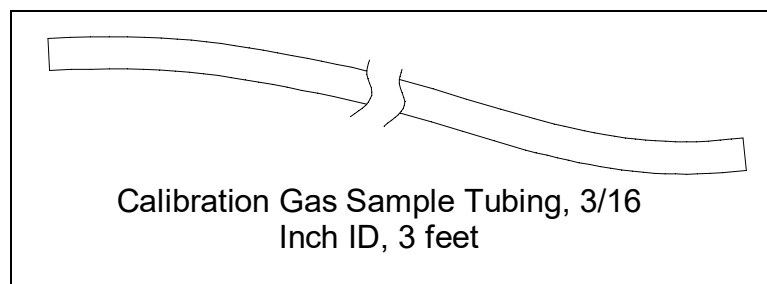

Figure 6: Air Filter & Exhaust Tubing

Single-Station AC Adapter

The single-station AC adapter is a wall plug style adapter with a 4 foot cable. The end of the cable has a plug that connects to the SDM-3R's power jack. A screw included with the SDM-3R allows you to secure the plug to the SDM-3R's jack if desired. The AC adapter is rated 100 - 240 VAC input, 5.99 VDC 2 A output.

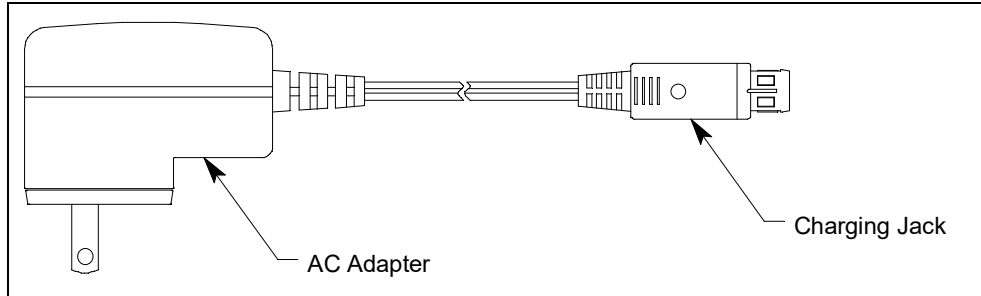

Figure 7: Single-Station AC Adapter

USB Cable

A Type A to Type B USB cable is used to connect the SDM-3R to a PC which is required for setting up the LAN connectivity function of the SDM-3R or for using the SDM-3R in the PC Controlled configuration. If you have a multi-station system, each SDM-3R must be individually connected to the PC.

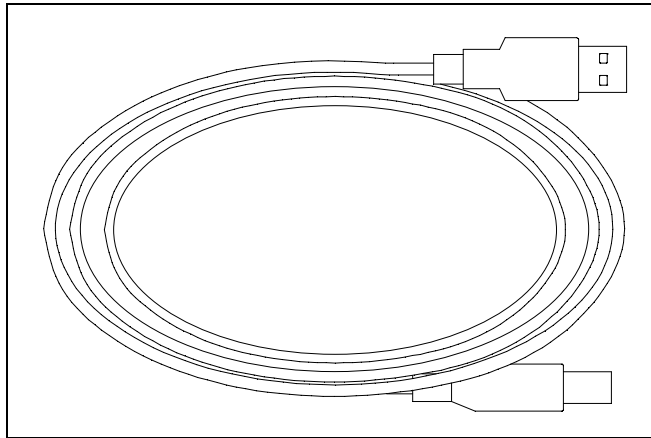

Figure 8: USB Cable

Ethernet Cable

A 5 foot length of black Ethernet cable allows for the LAN connectivity function of the SDM-3R to be used. One end of the cable is plugged into the LAN port on the left side of the SDM-3R and the other end is plugged into one of the building's network ports. If you have a multi-station system, each SDM-3R must have its own Ethernet connection.

USB Drive

A USB drive is used for copying data from the SDM-3R's memory and importing it into the PC Program.

Optional Accessories

Connection Brackets

The SDM-3Rs can be mechanically connected to each other using the connection brackets.

Wall Mounting Brackets

The SDM-3R can be mounted to the wall, if desired, using 2 mounting brackets. See “Wall Mounting the SDM-3R, Optional” on page 19 for a description of how many wall mounting brackets are needed depending on how many SDM-3Rs are in your system.

Cylinder Holders

A cylinder holder allows a calibration cylinder to securely sit on a desktop or benchtop.

Demand Flow Regulator

A demand flow regulator installs on a calibration cylinder to allow the SDM-3R to draw calibration gas.

Calibration Cylinder

A cylinder with a known gas concentration must be used for bump testing and calibration.

CO₂ Scrubber

A CO₂ scrubber can be used in place of a N₂ cylinder for zeroing the CO₂ sensor. The scrubber has a flow direction and needs to be installed correctly when used.

A single piece of tubing connects both ends of the scrubber when not in use. To prolong the life of the scrubber, be sure the tubing is connected to both ends of the scrubber while the scrubber is not in use or while it is being stored.

Replace the scrubber when you notice the pellets in the scrubber tube beginning to break down into powder.

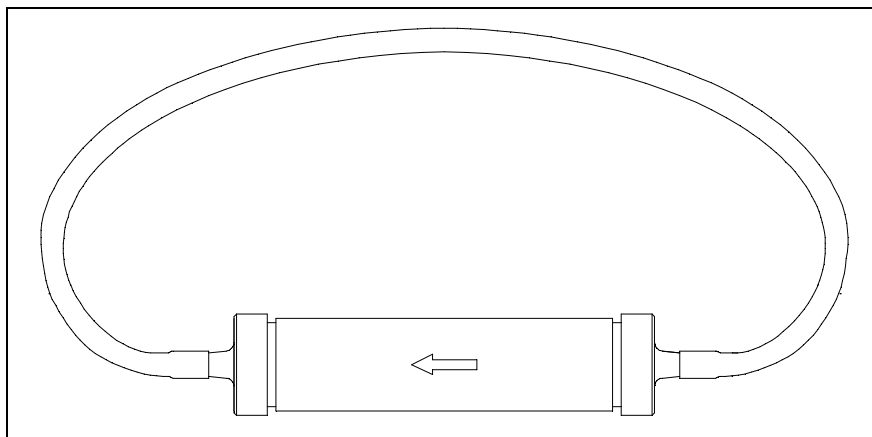

Figure 9: CO₂ Scrubber

Chapter 3: Mechanical Setup of SDM-3R

Overview

Mechanical setup for the SDM-3R includes:

- connecting multiple SDM-3Rs together, optional (pg. 17)
- assembling the hardware (pg. 19)
- wall mounting the station, optional (pg. 19)
- connecting calibration gas (pg. 23)

Connecting Multiple SDM-3Rs Together, Optional

Up to 10 SDM-3Rs can be connected together.

- 1 . Be sure that the SDM-3Rs are not connected to power.
- 2 . For every station except the one that will be located on the far right side of the bank:
 - a. Unscrew the two screws that retain the panel on the right side of the station. The screws are not captive. Be sure not to lose them.
 - b. Pull the panel away from the SDM-3R.
 - c. Use needle nosed pliers to remove the clear plugs that are installed in the four mating sample fittings.
 - d. Save the panel, the screws, and the four plugs in a safe place.

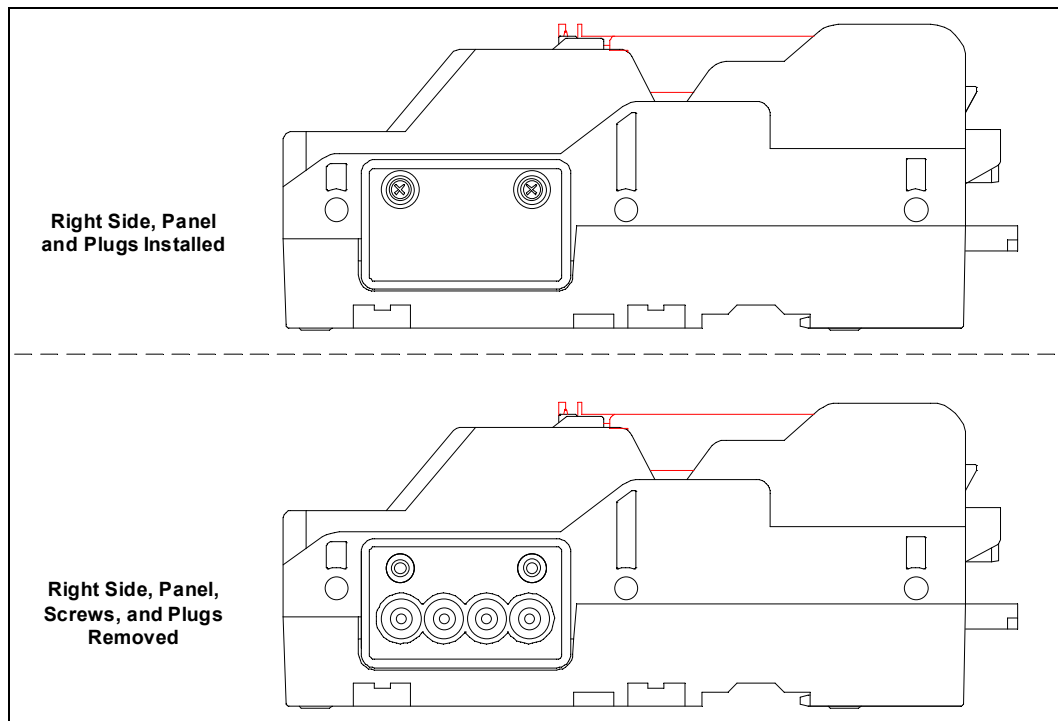

Figure 10: Panel and Plug Removal

- 3 . Starting with the two left-most stations, line up the sample fitting connections and push the two stations together until the housings are touching.
- 4 . Add stations to the right side of the bank using the same procedure. The last station installed should be the one that still has a panel on the right side.
- 5 . (Optional) Use the metal connection brackets and screws (sold separately) to secure the two connection points on the bottom of the SDM-3R to each other.

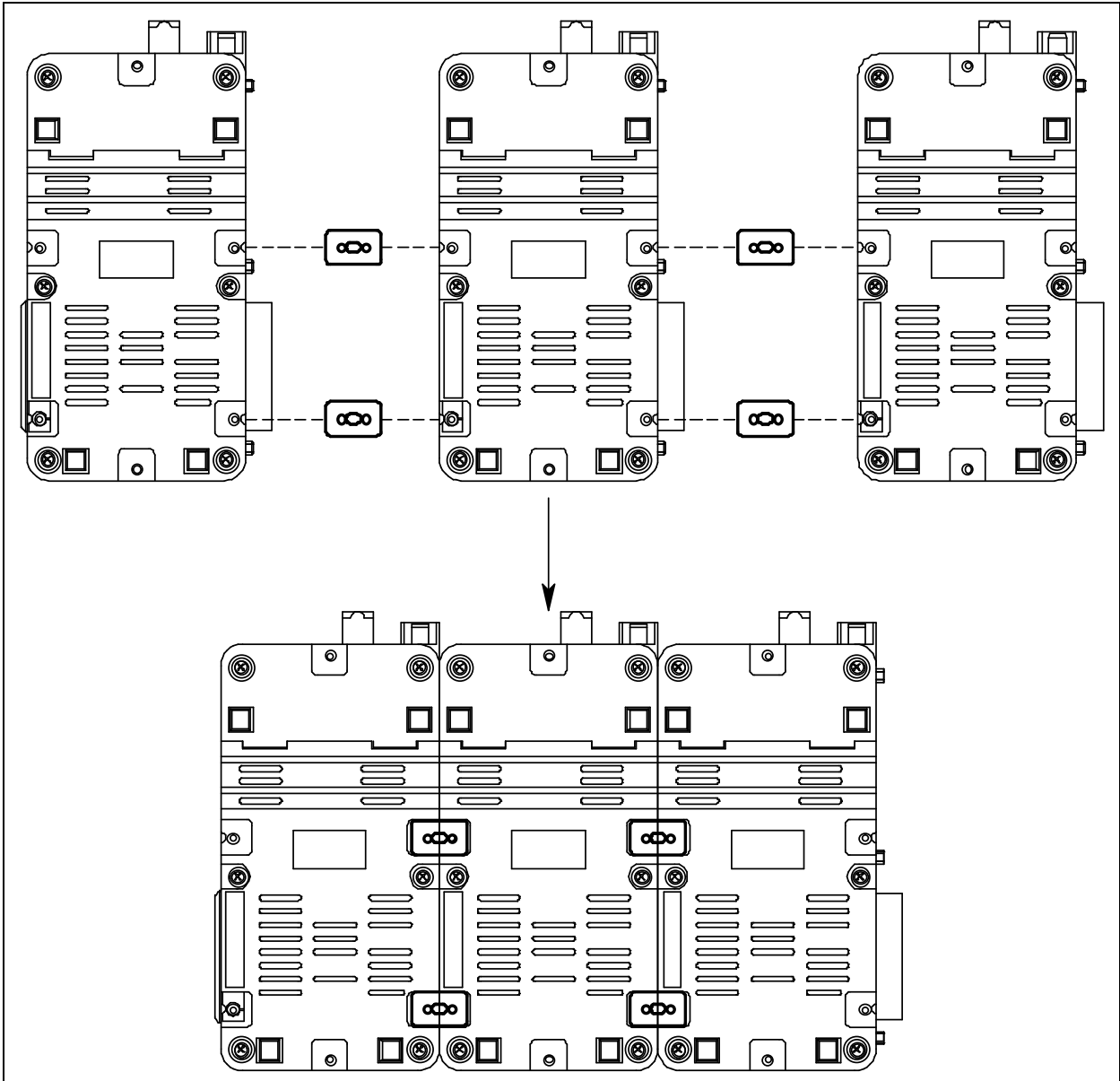

Figure 11: Connecting SDM-3Rs Together

Hardware Assembly

The hardware assembly consists of connecting the AC adapter, installing the air filter, and connecting the exhaust tubing. Perform the following to complete the hardware assembly:

- 1 . Place the SDM-3R(s) on a convenient table top near an AC wall socket in a well ventilated area. A location near a window that can be opened is best so that the exhaust can be routed to the window.
- 2 . Connect the AC adapter's wall plug into a wall AC socket.
- 3 . Insert the plug on the end of the AC adapter's output cable into the power jack on the back of the SDM-3R. If desired, use the screw provided in the bag with the particle filter to secure the AC adapter to the SDM-3R.

NOTE: If you have multiple SDM-3Rs connected to each other, each SDM-3R needs its own power.

- 4 . Install the air filter so that the arrow on the filter that indicates direction of flow is pointing towards the AIR fitting.
- 5 . Install the 10 foot long 5/16 inch ID flexible tube that is included with the SDM-3R on the exhaust fitting. Route the tube to an area where the exhaust can be safely dispersed, such as an open window. Exhaust tubing from multiple SDM-3Rs cannot be manifolded together.

CAUTION: *The maximum recommended length for the exhaust tube is 15 feet. Using tubing longer than 15 feet or with an ID smaller than 5/16 inch may adversely affect bump test and calibration accuracy.*

Wall Mounting the SDM-3R, Optional

Single SDM-3Rs or multiple SDM-3Rs connected together as described in “Connecting Multiple SDM-3Rs Together, Optional” on page 17 can be mounted to the wall using mounting brackets. The wall mounting brackets are not supplied as standard with the SDM-3R. If you are wall mounting a bank of SDM-3Rs, not every SDM-3R will need wall mounting brackets but each SDM-3R that will use wall mounting brackets needs 3. See the figure below to determine how many wall mounting brackets you need to order.

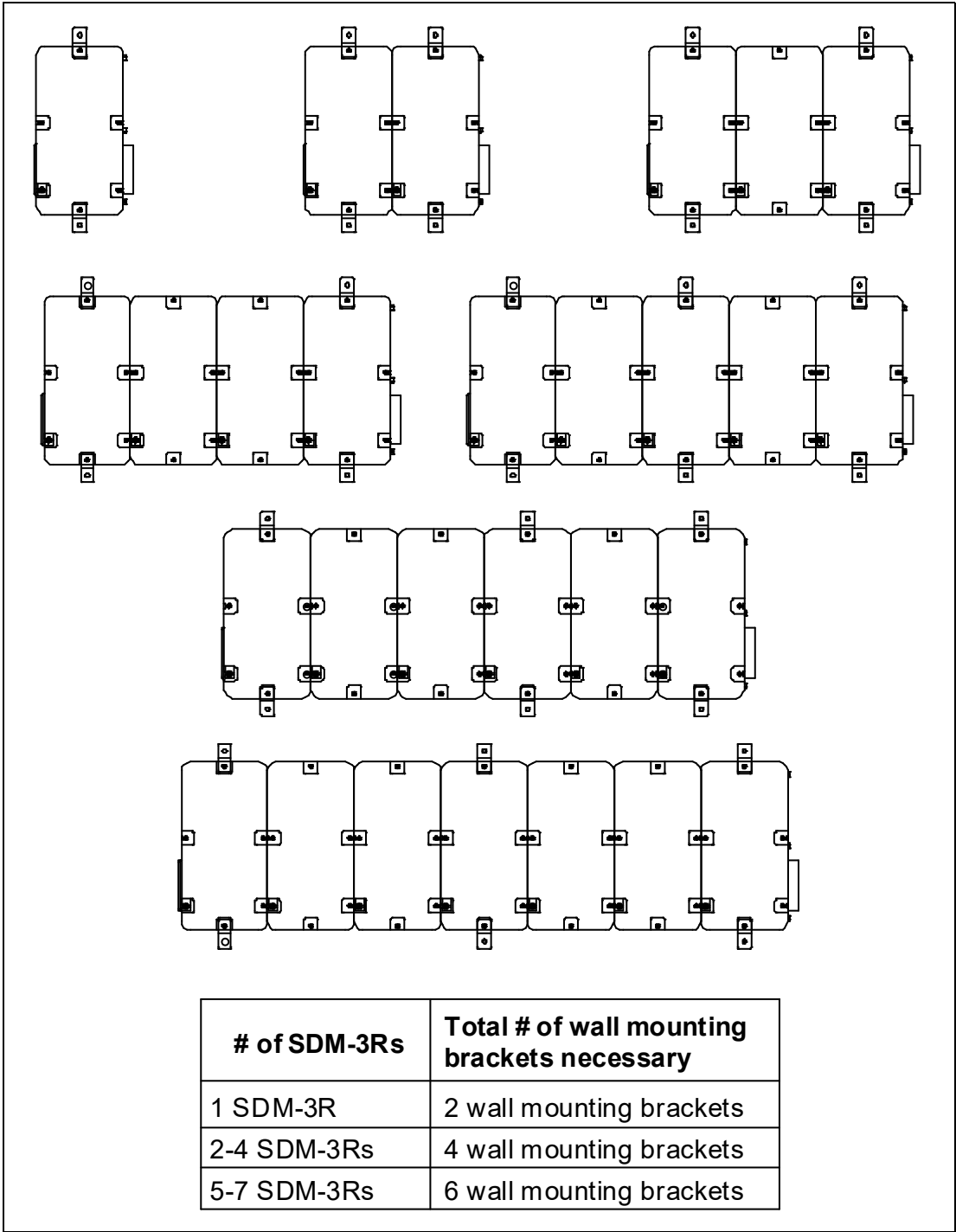

Figure 12: Wall Mounting 1-7 SDM-3Rs

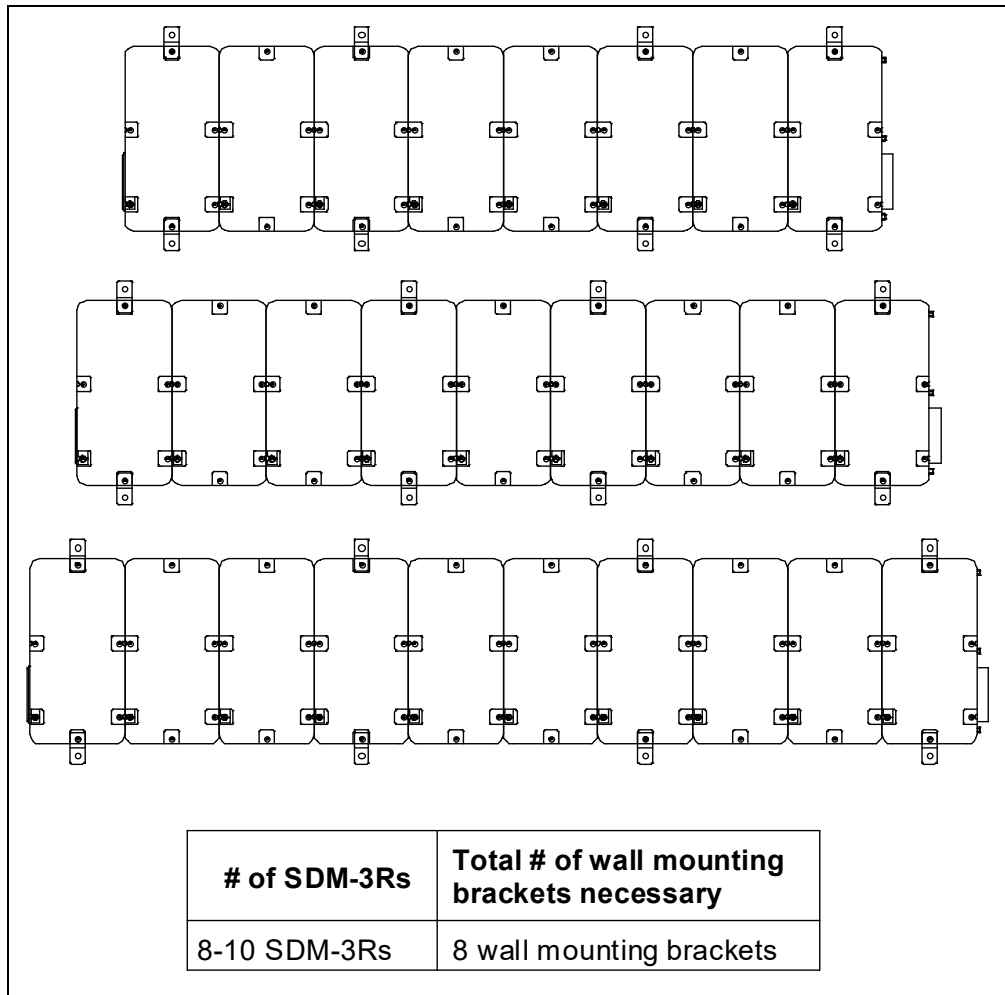

Figure 13: Wall Mounting 8-10 SDM-3Rs

- 1 . If you are mounting multiple SDM-3Rs, be sure your SDM-3Rs are properly connected and secured to each other.

- 2 . Connect the wall mounting brackets to the SDM-3R(s) using the provided screws. The wall mounting brackets are not straight. They have a short section and a long section. The short section has a smaller hole than the long section. Screw the short section into the SDM-3R making sure that the long section goes away from the station and is flush with the back of the SDM-3R.

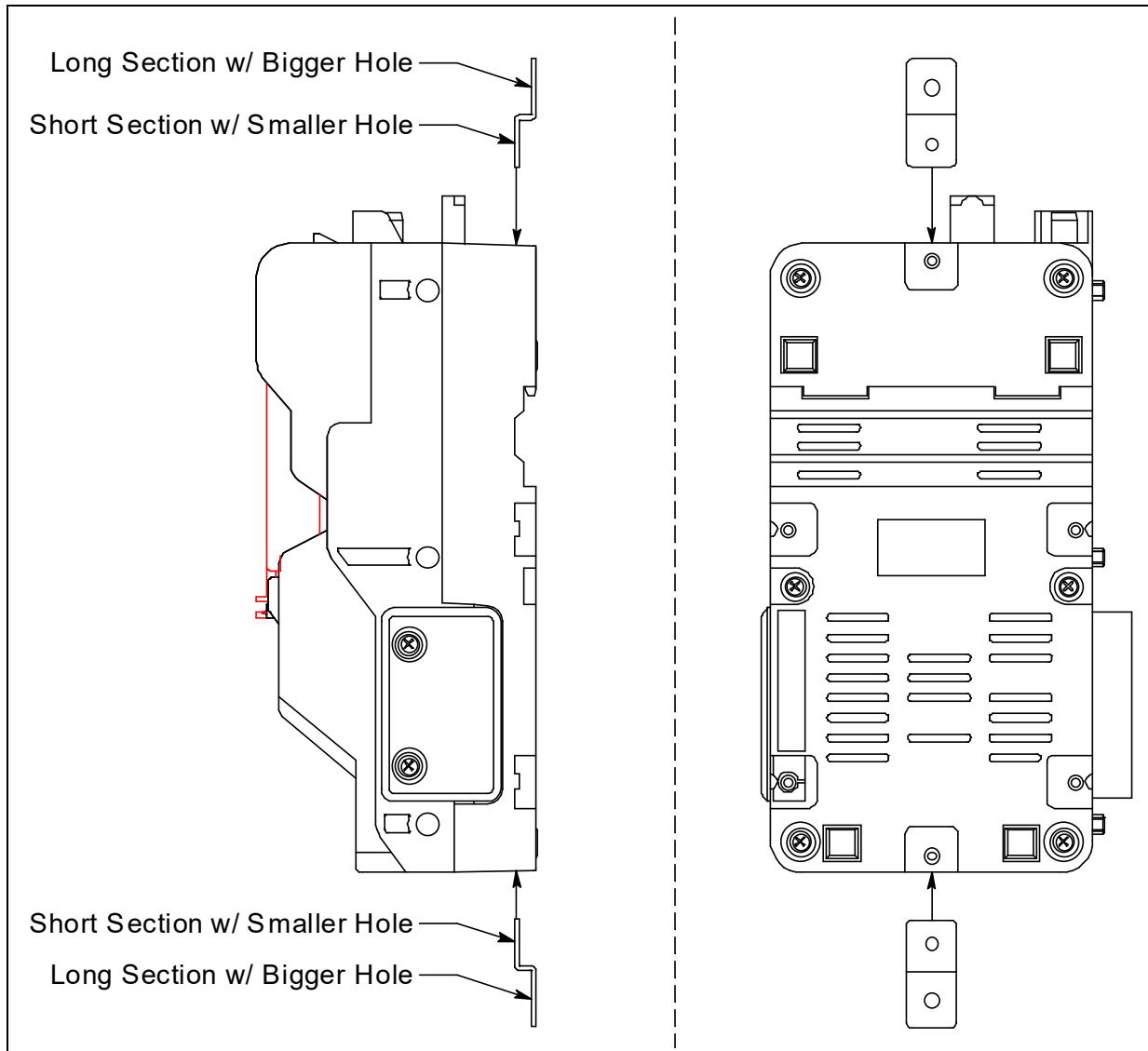

Figure 14: Wall Mounting Bracket Installation

- 3 . Position the SDM-3R(s) on the wall where you intend to mount them.
- 4 . Screw the wall mounting brackets into the wall. Make sure the mounting screws and the material they are screwed into are appropriate to support the weight of the system.

Installing the Cylinder Holder, Optional

1. Choose a location for the calibration cylinders that is close to the SDM-3R.
2. 4 pads with adhesive on each side are included with each cylinder holder.

3. Remove the backing from one side of each pad and stick it to a corner on the bottom of the cylinder holder. If desired and/or practical, 2 pads can be used for the bottom and 2 pads can be used for the back.
4. Remove the backing from each of the installed pads and press the cylinder holder firmly into position.

Connecting Calibration Gas

The GAS 1, GAS 2, and GAS 3 fittings on the left side of the docking station are designed to be used with a calibration gas cylinder that is fitted with a demand flow regulator. See pg. 74 for part numbers of available cylinders.

The number of active gas fittings depends on how many solenoid valves are installed in your docking station. The AIR and GAS 1 fittings are always active. The GAS 2 and GAS 3 fittings are only active if the docking station was ordered with 2 or 3 solenoid valves, respectively.

AIR

The AIR fitting needs either:

- a. A cylinder of zero emissions air

OR

- b. A fresh air area

GAS 1 - GAS 3 Cylinders

See the tables below for information about necessary calibration cylinders and what inlet to connect them to.

If testing different GX-3R (Pro) combinations at once requires more than 3 cylinders, you can assign a channel to **CHG 3** in the SDM-3R's Configuration Menu and the SDM will prompt you to change cylinders during a bump test or calibration. You cannot change cylinders more than once during a test.

Table 2: Cylinder and Inlet Examples

Instrument Types		Gas Inlet: Calibration Cylinder
All Instruments: 3-gas (LEL/Oxy/CO)		GAS 1: 3-gas mix with LEL/Oxy/CO
All Instruments: 3-gas (LEL/Oxy/H2-compensated CO)		GAS 1: 3-gas mix with LEL/Oxy/CO GAS 2: H2 (only needed if calibrating a newly-installed replacement H2-compensated CO sensor)
All Instruments: 3-gas (LEL/Oxy/CO) + CO2	Option 1	GAS 1: 3-gas mix with LEL/Oxy/CO in air GAS 2: N2 (or CO2 scrubber) GAS 3: CO2
	Option 2	GAS 1: 4-gas mix with LEL/Oxy/CO/CO2 GAS 2: N2 (or CO2 scrubber)
	Option 3	GAS 1: 3-gas mix with LEL/Oxy/CO in N2 GAS 2: CO2

Table 2: Cylinder and Inlet Examples

Instrument Types		Gas Inlet: Calibration Cylinder
All Instruments: 3-gas (LEL/Oxy/CO) + SO2		GAS 1: 3-gas mix with LEL/Oxy/CO GAS 2: SO2
All Instruments: 4-gas (LEL/Oxy/CO/H2S)		GAS 1: 4-gas mix with LEL/Oxy/CO/H2S
All Instruments: 4-gas (LEL/Oxy/H2-compensated CO/H2S)		GAS 1: 4-gas mix with LEL/Oxy/CO/H2S GAS 2: H2 (only needed if calibrating a newly-installed replacement H2-compensated CO sensor)
All Instruments: 4-gas (LEL/Oxy/CO/H2S) + IR CO2	Option 1	GAS 1: 4-gas mix with LEL/Oxy/CO/H2S in air GAS 2: N2 (or CO2 scrubber) GAS 3: CO2
	Option 2	GAS 1: 5-gas mix with LEL/Oxy/CO/H2S/CO2 GAS 2: N2 (or CO2 scrubber)
	Option 3	GAS 1: 4-gas mix with LEL/Oxy/CO/H2S in N2 GAS 2: CO2
All Instruments: 4-gas (LEL/Oxy/CO/H2S) + SO2	Option 1	GAS 1: 5-gas mix with LEL/Oxy/CO/H2S/SO2
	Option 2	GAS 1: 4-gas mix with LEL/Oxy/CO/H2S GAS 2: SO2
Instrument 1: 3-gas (LEL/Oxy/CO) + SO2 Instrument 2: 3-gas (LEL/Oxy/CO) + IR CO2	Option 1	GAS 1: 3-gas mix with LEL/O2/CO in air GAS 2: SO2 GAS 3: N2 (or CO2 scrubber) CHG 3: CO2
	Option 2	GAS 1: 4-gas mix with LEL/O2/CO/CO2 GAS 2: SO2 GAS 3: N2 (or CO2 scrubber)
	Option 3	GAS 1: 3-gas mix with LEL/O2/CO in N2 GAS 2: SO2 GAS 3: CO2
Instrument 1: 4-gas (LEL/Oxy/CO/H2S) + SO2 Instrument 2: 4-gas (LEL/Oxy/CO/H2S) + IR CO2	Option 1	GAS 1: 5-gas mix with LEL/Oxy/CO/H2S/SO2 GAS 2: N2 (or CO2 scrubber) GAS 3: CO2
	Option 2	GAS 1: 4-gas mix with LEL/Oxy/CO/H2S in air GAS 2: SO2 GAS 3: N2 (or CO2 scrubber) CHG 3: CO2
	Option 3	GAS 1: 5-gas mix with LEL/Oxy/CO/H2S/CO2 GAS 2: SO2 GAS 3: N2 (or CO2 scrubber)
	Option 4	GAS 1: 4-gas mix with LEL/Oxy/CO/H2S in N2 GAS 2: SO2 GAS 3: CO2

Table 2: Cylinder and Inlet Examples

Instrument Types		Gas Inlet: Calibration Cylinder
Instrument 1: 4-gas + SO ₂ Instrument 2: 4-gas (H ₂ -compensated CO)	Option 1	GAS 1: 5-gas mix with LEL/Oxy/CO/H ₂ S/SO ₂ GAS 2: H ₂ (only needed if calibrating a newly-installed replacement H ₂ -compensated CO sensor)
	Option 2	GAS 1: 4-gas mix with LEL/Oxy/CO/H ₂ S GAS 2: SO ₂ GAS 3: H ₂ (only needed if calibrating a newly-installed replacement H ₂ -compensated CO sensor)

Connecting Calibration Cylinders

- 1 . If the area around the docking station is not considered a fresh air area (an area free of combustible and toxic gases and of normal oxygen content, 20.9%) install a tube not longer than 10 feet on the filter attached to the AIR fitting on the left side of the docking station and route it to a fresh air area or connect a cylinder of zero air with a demand flow regulator to the AIR fitting.
- 2 . Install the demand flow regulator(s) on the calibration gas cylinder(s).

NOTE: Do not connect pressurized gas directly to the SDM-3R. Be sure to install a demand flow regulator on the cylinder before connecting it to the SDM-3R.

- 3 . Connect the demand flow regulator to the appropriate inlet fitting using 3/16 inch ID sample tubing.
- 4 . If you plan to use a CO₂ scrubber to zero the CO₂ sensor, do not connect the CO₂ scrubber yet. Prolong the life of the CO₂ scrubber by only connecting it to the SDM-3R when you need to use it. Store the CO₂ scrubber with the tubing connected to both ends.

Chapter 4: Parameter Setup in SDM-3R's Config Menu

Once the hardware has been assembled, use the Config Menu to confirm or adjust the items in Table 3 below. Even if you have mechanically connected multiple docking stations, you must set up your desired operation for each docking station. There is no master station that controls the others.

Table 3: Config Menu Items

Menu Item	GX-3R Display Tag	GX-3R Pro Display Tag
Bump test parameters (pg. 26)	BP TEST	BUMP
Calibration parameters (pg. 31)	CAL	CAL
Gas cylinder assignments (pg. 34)	CYLNDER	CYLINDER
Date and time (pg. 37); must adjust upon receipt in order for saved data to have correct date/time	DATE	DATE
Password (pg. 39)	PASS	PASSWORD

Bump Test Parameters

There are nine bump test parameters. Table 4 below describes the parameters and shows the factory settings. If you wish to use the factory settings, then you do not need to make any parameter adjustments. If you wish to confirm or change the parameter settings, follow the instructions below.

Table 4: Bump Test Parameters

Parameter	GX-3R Display Tag	GX-3R Pro Display Tag	Available Choices	Factory Setting
Pre-Sample Flush Time	AIR FL	AIR FLUSH	15 - 120 seconds in 1 second increments	15 seconds
Calibration Gas Sample Time	GAS TIME	GAS TIME	20 - 120 seconds in 1 second increments	20 seconds
Post-Sample Purge Time	AIR PG	AIR PURGE	5 - 120 seconds in 1 second increments	15 seconds
Bump Test Check Tolerance	TOLERANC	TOLERANCE	10% - 50% in 1% increments	50%
Automatic Calibration	AUTO CAL	AUTO CAL	<ul style="list-style-type: none"> • On • Off 	On
Fast Bump	FASTBUMP	FAST BUMP	<ul style="list-style-type: none"> • On • Off 	On

Table 4: Bump Test Parameters

Parameter	GX-3R Display Tag	GX-3R Pro Display Tag	Available Choices	Factory Setting
Alarm Check	ALARM C	ALARM CHECK	<ul style="list-style-type: none"> • On • Off 	On
Automatically Bump Test if Past Due	BUMP EXP	BUMP EXPIRED	<ul style="list-style-type: none"> • On • Off 	Off
Automatically Bump Test at Instrument Turn On	AUTO EXE	AUTO EXEC	<ul style="list-style-type: none"> • On • Off 	Off

Pre-Sample Flush Time (AIR FL/AIR FLUSH)

The pre-sample flush time is the length of time that the SDM-3R will draw air through the AIR fitting before performing an air adjust operation.

NOTE: If the GX-3R (Pro) is not on for 40 seconds before a bump test is initiated, air will flow until the GX-3R (Pro) has been on for 40 seconds regardless of the time selected here.

Calibration Gas Sample Time (GAS TIME)

The calibration gas sample time is the length of time that the SDM-3R will draw calibration gas through each of the gas fittings.

Post-Sample Purge Time (AIR PG/AIR PURGE)

The post-sample purge time is the length of time that the SDM-3R will draw air through the AIR fitting to purge calibration gas from the system.

Bump Test Check Tolerance (TOLERANC/TOLERANCE)

The amount that the GX-3R (Pro) gas reading differs from the calibration gas concentration must be equal to or less than this percentage of the gas concentration in order to pass the bump test. For example, if the tolerance is set to 50%, and the %LEL calibration gas concentration is 50% LEL, then the bump test gas reading for the LEL channel on the GX-3R (Pro) must be 50 %LEL ± 25 %LEL.

Automatic Calibration (AUTO CAL)

If AUTO CAL is set to On, then the docking station will automatically perform a calibration if a bump test fails.

Fast Bump (FAST BUMP)

Turning Fast on allows calibration gas to be saved when the tested sensors respond quickly and accurately.

If FAST BUMP is set to Off, the gas application during a bump test will continue for the time period defined by the GAS TIME bump test parameter regardless of the sensor reading(s).

If FAST BUMP is set to On and the gas reading for the sensor(s) being tested is within the bump test

tolerance defined in TOLERANC/TOLERANCE at the end of a 10 second gas application and a 10 second stabilization period, the sensor(s) pass bump testing, the gas application will be stopped, and the test will move on to the next sensor(s) or to the fresh air purge.

If the gas reading on any of the tested channels is outside of the bump test tolerance defined in TOLERANC/TOLERANCE at the end of the 10 second gas application and a 10 second stabilization period, the bump test will fail and the next step will depend on the AUTO CAL setting.

Consider the following scenario as an example.

- 50% LEL methane used for bump testing the combustible gas channel
- Tolerance set to $\pm 50\%$, which means that the acceptable reading range is 25% LEL - 75% LEL
- FAST BUMP set to On

The table below shows possible readings after the 10 second gas application and the 10 second stabilization period.

Table 5: Example Fast Bump Scenarios

Gas Reading After 10 Seconds of Gas Application and a 10 Second Stabilization Period	Outcome
15% LEL (-70% of 50% LEL)	<ul style="list-style-type: none"> • Bump test fails • Next step depends on AUTO CAL setting
30% LEL (-40% of 50% LEL)	<ul style="list-style-type: none"> • Gas application stops • Sensor passes bump testing
60% LEL (+20% of 50% LEL)	<ul style="list-style-type: none"> • Gas application stops • Sensor passes bump testing
80% LEL (+60% of 50% LEL)	<ul style="list-style-type: none"> • Bump test fails • Next step depends on AUTO CAL setting

Alarm Check (ALARM C/ALARM CHECK)

If Alarm Check is selected, a vibrator, LED, and buzzer test is done on the GX-3R (Pro) at the end of the bump test. The vibrator will vibrate, the LEDs will turn on for a few seconds, the buzzer will sound, and the SDM-3R will determine if these actions were completed successfully.

Automatically Bump Test if Past Due (BUMP EXP/BUMP EXPIRED)

If BUMP EXP/BUMP EXPIRED is set to On and if the connected GX-3R (Pro) is due for a bump test, the SDM-3R will automatically perform a bump test on all channels when the GX-3R (Pro) is connected.

If BUMP EXP/BUMP EXPIRED is set to Off, an automatic bump test will not be performed, even if the GX-3R (Pro) is due for one.

Automatically Bump Test at Instrument Turn On (AUTO EXE/AUTO EXEC)

If AUTO EXE/AUTO EXEC is set to On, the SDM-3R will automatically perform a bump test on all channels when the GX-3R (Pro) is connected, regardless of whether it's due for bump testing.

Viewing or Changing the Bump Parameters

NOTE: All screens in this section are for the GX-3R Pro. Your GX-3R screens will be different.

- 1 . Press the POWER button to turn on the SDM-3R.
- 2 . Install the GX-3R (Pro) into the SDM-3R's instrument cradle. Be sure the yellow lever is up for a GX-3R and down for a GX-3R (Pro).
- 3 . Close the red door. The GX-3R (Pro) will automatically turn on and connect to the SDM-3R.

CH4	%LEL	CO	ppm	H2S	ppm
	50		50		25.0
O2	%	CO2			vol%
	12.0				2.50
TRANSMIT					

- 4 . Press the EDIT ENTER button. If Password is set to on (factory setting is off), you will be prompted for a password. Use BUMP ▼ and CAL ▲ to adjust a digit and the EDIT ENTER button to save it and move to the next digit.

0 0 0 0
SETTING

- 5 . The Configuration Menu will be displayed.

> BUMP
CAL
CYLINDER
SETTING

- 6 . Press BUMP ▼ to scroll to BUMP.
- 7 . Press and release EDIT ENTER. The AIR FLUSH parameter will display.

8 . Use BUMP ▼ and CAL ▲ to scroll through the bump parameter settings.

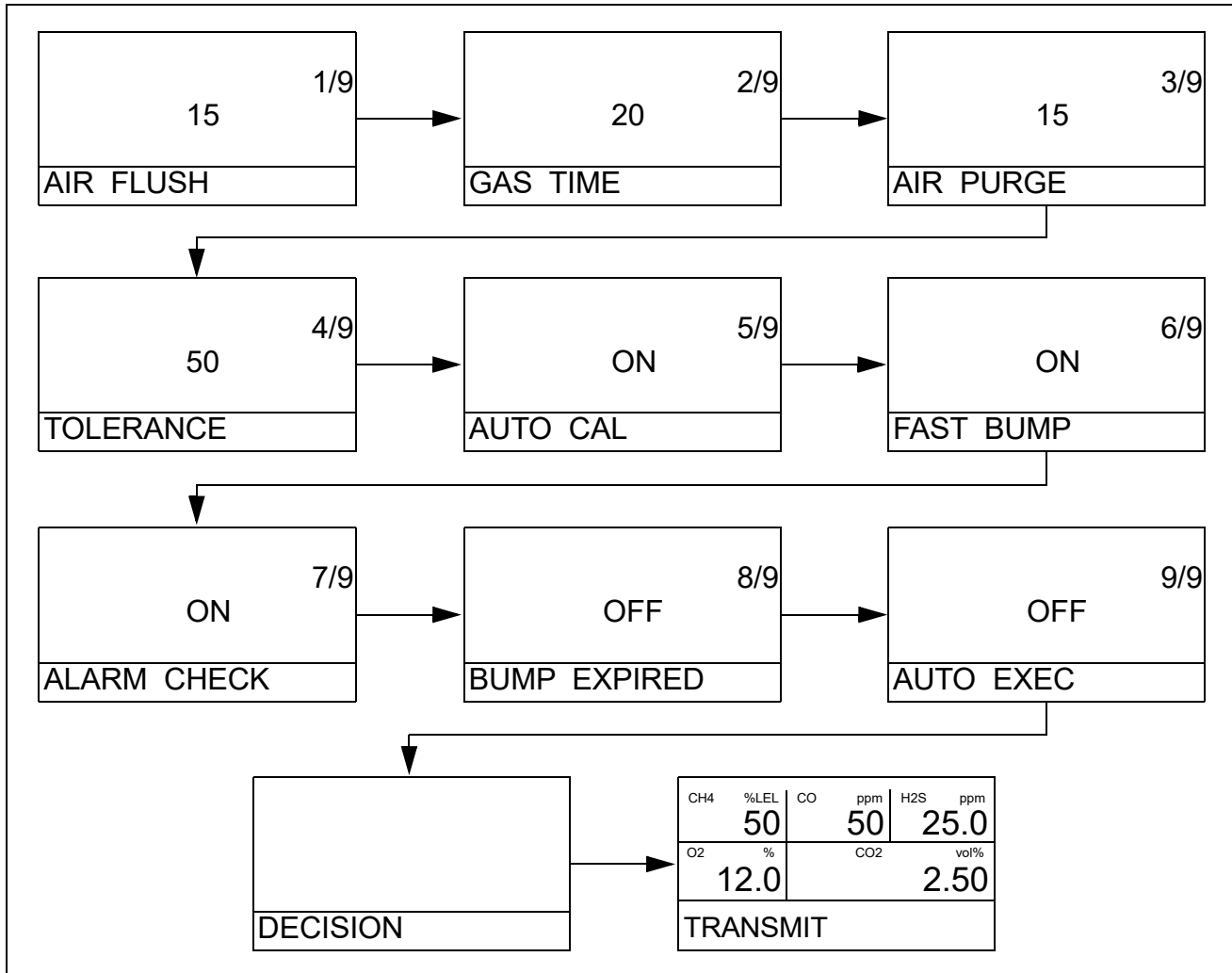

- 9 . To change a parameter, press and release EDIT ENTER. The current value will begin to flash. Use BUMP ▼ and CAL ▲ to change a value. Press and release EDIT ENTER to save the change.
- 10 .When you are done setting the parameters, press BUMP ▼ until DECISION appears. The SDM-3R returns to the Configuration Menu.
- 11 .To exit the Configuration Menu and return to the main screen, scroll to ESCAPE and press and release EDIT ENTER.

Calibration Parameters

There are six calibration parameters. Table 6 below describes the parameters and shows the factory settings. If you wish to use the factory settings, then you do not need to make any parameter adjustments. If you wish to confirm or change the parameter settings, follow the instructions below.

Table 6: Calibration Parameter

Parameter	GX-3R Display Tag	GX-3R Pro Display Tag	Available Choices	Factory Setting
Pre-Sample Flush Time	AIR FL	AIR FLUSH	15 - 120 seconds in 1 second increments	15 seconds
Calibration Gas Sample Time	GAS TIME	GAS TIME	20 - 120 seconds in 1 second increments	60 seconds
Post-Sample Purge Time	AIR PG	AIR PURGE	5 - 120 seconds in 1 second increments	15 seconds
Alarm Check	ALARM C	ALARM CHECK	<ul style="list-style-type: none"> • On • Off 	On
Automatically Calibrate if Past Due	CAL EXP	CAL EXPIRED	<ul style="list-style-type: none"> • On • Off 	Off
Automatically Calibrate at Instrument Turn On	AUTO EXE	AUTO EXEC	<ul style="list-style-type: none"> • On • Off 	Off
Manual Calibration	MANUAL C	MANUAL CAL	<ul style="list-style-type: none"> • On • Off 	On

Pre-Sample Flush Time (AIR FL/AIR FLUSH)

The pre-sample flush time is the length of time that the SDM-3R will draw air through the AIR fitting before performing an air adjust operation.

NOTE: If the GX-3R (Pro) is not on for 40 seconds before a calibration is initiated, air will flow until the GX-3R (Pro) has been on for 40 seconds regardless of the time selected here.

Calibration Gas Sample Time (GAS TIME)

The calibration gas sample time is the length of time that the SDM-3R will draw calibration gas through each of the gas fittings.

Post-Sample Purge Time (AIR PG/AIR PURGE)

The post-sample purge time is the length of time that the SDM-3R will draw air through the AIR fitting to purge calibration gas from the system.

Alarm Check (ALARM C/ALARM CHECK)

If Alarm Check is set to On, a vibrator, LED, and buzzer test is done on the GX-3R (Pro) at the end of the calibration. The vibrator will vibrate, the LEDs will turn on for a few seconds, the buzzer will sound, and the SDM-3R will determine if these actions were completed successfully.

Automatically Calibrate if Past Due (CAL EXP/CAL EXPIRED)

If CAL EXP/CAL EXPIRED is set to On and if the connected GX-3R (Pro) is due for a calibration, the SDM-3R will automatically perform a calibration on all channels when the GX-3R (Pro) is connected.

If CAL EXP/CAL EXPIRED is set to Off, an automatic calibration will not be performed, even if the GX-3R (Pro) is due for one.

Automatically Calibrate at Instrument Turn On (AUTO EXE/AUTO EXEC)

If AUTO EXE/AUTO EXEC is set to On, the SDM-3R will automatically perform a calibration on all channels when the GX-3R (Pro) is connected.

Manual Calibration (MANUAL C/MANUAL CAL)

If MANUAL C/MANUAL CAL is set to On, a calibration can be initiated by pressing the CAL ▲ button. If MANUAL C/MANUAL CAL is set to Off, a calibration cannot be manually initiated.

Viewing or Changing the Calibration Parameters

NOTE: All screens in this section are for the GX-3R Pro. Your GX-3R screens will be different.

- 1 . Press the POWER button to turn on the SDM-3R.
- 2 . Install the GX-3R (Pro) into the SDM-3R's instrument cradle. Be sure the yellow lever is up for a GX-3R and down for a GX-3R (Pro).
- 3 . Close the red door. The GX-3R (Pro) will automatically turn on and connect to the SDM-3R.

CH4	%LEL	CO	ppm	H2S	ppm
	50		50		25.0
O2	%	CO2			vol%
	12.0				2.50
TRANSMIT					

- Press the EDIT ENTER button. If Password is set to on (factory setting is off), you will be prompted for a password. Use BUMP ▼ and CAL ▲ to adjust a digit and the EDIT ENTER button to save it and move to the next digit.

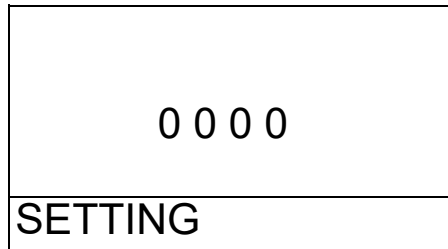

- The Configuration Menu will be displayed.

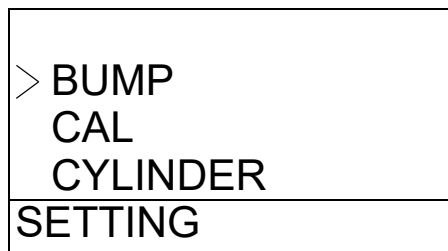

- Press BUMP ▼ to scroll to CAL.
- Press and release EDIT ENTER. The AIR FLUSH parameter will display.
- Use BUMP ▼ and CAL ▲ to scroll through the calibration parameter settings.

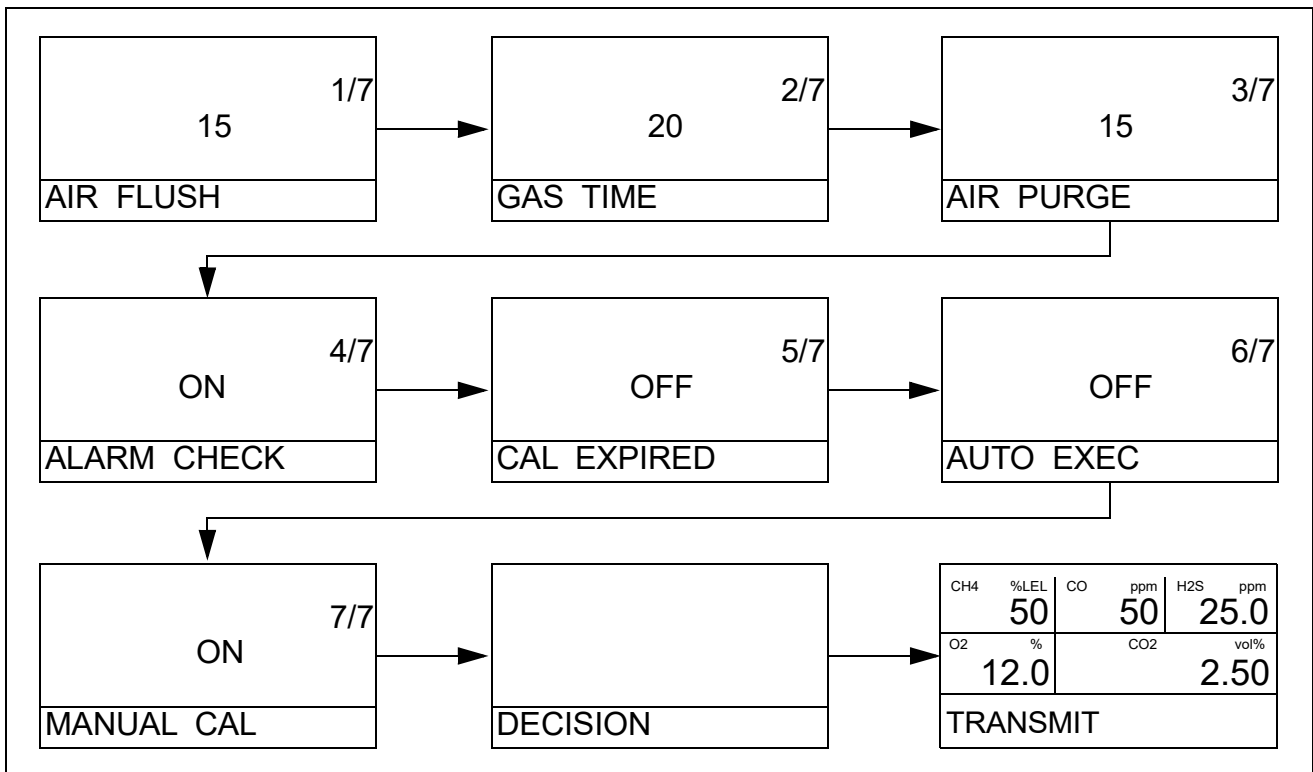

- 9 . Press and release EDIT ENTER to enter a screen. Use BUMP ▼ and CAL ▲ to change a value. Press and release EDIT ENTER to save the change.
- 10 .When you are done setting the parameters, press BUMP ▼ until DECISION appears. The SDM-3R returns to the Configuration Menu.
- 11 .To exit the Configuration Menu and return to the main screen, scroll to ESCAPE and press and release EDIT ENTER.

Gas Cylinder Assignments

Assigning the gas cylinders defines what gas inlet each of the instrument's sensors will use for bump testing or calibration.

Your SDM-3R will only have as many gas inlet choices as it has solenoid valves. For example, an SDM-3R with only one solenoid valve will only have G1/GAS1, C1/CHG1, and OFF as a choice. A gas cylinder can only be changed once during a test.

Table 7: Gas Inlet Assignment Options

GX-3R Inlet Names	GX-3R Pro Inlet Names	Operation
G1	GAS1	Channel tested with gas applied through GAS1 inlet.
G2	GAS2	Channel tested with gas applied through GAS2 inlet.
G3	GAS3	Channel tested with gas applied through GAS3 inlet.
C3	CHG3	Channel tested with gas applied through GAS3 inlet after SDM-3R prompts you to change cylinders during bump testing or calibration.
OFF	OFF	Channel not tested

See the table below for gas inlet assignment examples. See pg. 23 for a more detailed explanation of cylinder requirements.

Table 8: Gas Inlet Assignment Examples

Instrument Types		Gas Inlet Assignment
3-gas (LEL/Oxy/CO)		GAS 1: 3-gas mix with LEL/Oxy/CO
3-gas (LEL/Oxy/H2-compensated CO)		GAS 1: 3-gas mix with LEL/Oxy/CO GAS 2: H2 (only needed if calibrating a newly-installed replacement H2-compensated CO sensor)
3-gas (LEL/Oxy/CO) + CO2	Option 1	GAS 1: 3-gas mix with LEL/Oxy/CO in air GAS 2: N2 (or CO2 scrubber) GAS 3: CO2
	Option 2	GAS 1: 4-gas mix with LEL/Oxy/CO/CO2 GAS 2: N2 (or CO2 scrubber)
	Option 3	GAS 1: 3-gas mix with LEL/Oxy/CO in N2 GAS 2: CO2
3-gas (LEL/Oxy/CO) + SO2		GAS 1: 3-gas mix with LEL/Oxy/CO GAS 2: SO2
4-gas (LEL/Oxy/CO/H2S)		GAS 1: 4-gas mix with LEL/Oxy/CO/H2S
4-gas (LEL/Oxy/H2-compensated CO/H2S)		GAS 1: 4-gas mix with LEL/Oxy/CO/H2S GAS 2: H2 (only needed if calibrating a newly-installed replacement H2-compensated CO sensor)
4-gas (LEL/Oxy/CO/H2S) + IR CO2	Option 1	GAS 1: 4-gas mix with LEL/Oxy/CO/H2S in air GAS 2: N2 (or CO2 scrubber) GAS 3: CO2
	Option 2	GAS 1: 5-gas mix with LEL/Oxy/CO/H2S/CO2 GAS 2: N2 (or CO2 scrubber)
	Option 3	GAS 1: 4-gas mix with LEL/Oxy/CO/H2S in N2 GAS 2: CO2
4-gas (LEL/Oxy/CO/H2S) + SO2	Option 1	GAS 1: 5-gas mix with LEL/Oxy/CO/H2S/SO2
	Option 2	GAS 1: 4-gas mix with LEL/Oxy/CO/H2S GAS 2: SO2

NOTE: All screens in this section are for the GX-3R Pro. Your GX-3R screens will be different.

- 1 . Press the POWER button to turn on the SDM-3R.
- 2 . Install the GX-3R (Pro) into the SDM-3R's instrument cradle. Be sure the yellow lever is up for a GX-3R and down for a GX-3R (Pro).

3 . Close the red door. The GX-3R (Pro) will automatically turn on and connect to the SDM-3R.

CH4	%LEL	CO	ppm	H2S	ppm
	50		50		25.0
O2	%	CO2		vol%	
	12.0			2.50	
TRANSMIT					

4 . Press the EDIT ENTER button. If Password is set to on (factory setting is off), you will be prompted for a password. Use BUMP ▼ and CAL ▲ to adjust a digit and the EDIT ENTER button to save it and move to the next digit.

0 0 0 0
SETTING

5 . The Configuration Menu will be displayed.

> BUMP CAL CYLINDER
SETTING

6 . Press BUMP ▼ to scroll to CYLINDER.

7 . Press and release EDIT ENTER. The LEL channel's cylinder assignment displays.

CH4	%LEL	CO	ppm	H2S	ppm
	GAS1				
O2	%	CO2		vol%	
CYLINDER					

- 8 . Use BUMP ▼ and CAL ▲ to scroll through the instrument channels. The example below shows a 4-gas (LEL, O₂, CO, H₂S) plus IR CO₂ instrument.

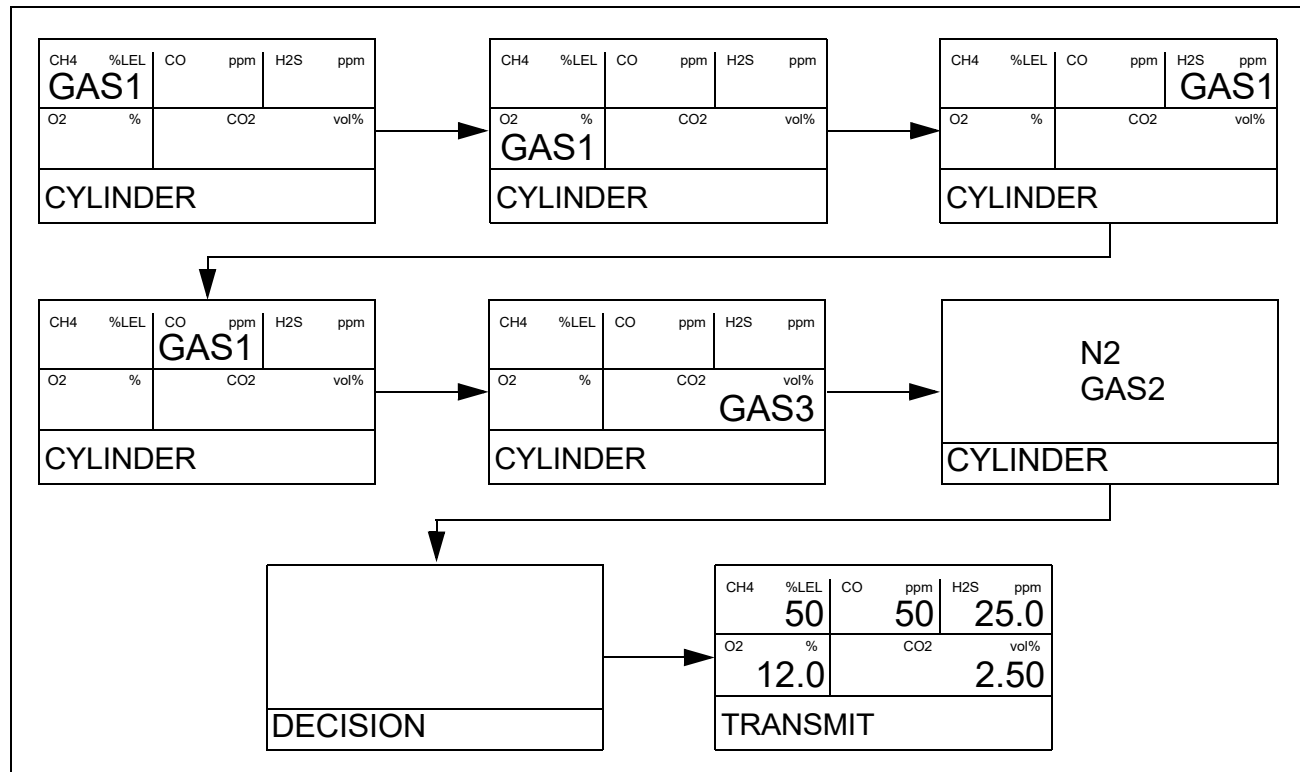

- 9 . Press and release EDIT ENTER to select a channel for editing. The current cylinder assignment will flash. Use BUMP ▼ and CAL ▲ to change the cylinder assignment. Press and release EDIT ENTER to save the change.
- 10 .When you are done assigning gas cylinders, press BUMP ▼ until DECISION appears. The SDM-3R returns to the Configuration Menu.
- 11 .To exit the Configuration Menu and return to the main screen, scroll to ESCAPE and press and release EDIT ENTER.

Date and Time

It is important to update the SDM-3R's date/time to match your time zone. The SDM-3R automatically updates the date/time in a connected GX-3R (Pro) to match the SDM-3R's date/time. If the date/time in your SDM-3R is not correct and you connect your GX-3R (Pro), the date/time in the GX-3R (Pro) will no longer be correct.

NOTE: All screens in this section are for the GX-3R Pro. Your GX-3R screens will be different.

- 1 . Press the POWER button to turn on the SDM-3R.
- 2 . Install the GX-3R (Pro) into the SDM-3R's instrument cradle. Be sure the yellow lever is up for a GX-3R and down for a GX-3R (Pro).

3 . Close the red door. The GX-3R (Pro) will automatically turn on and connect to the SDM-3R.

CH4	%LEL	CO	ppm	H2S	ppm
	50		50		25.0
O2	%	CO2	vol%		
	12.0		2.50		
TRANSMIT					

4 . Press the EDIT ENTER button. If Password is set to on (factory setting is off), you will be prompted for a password. Use BUMP ▼ and CAL ▲ to adjust a digit and the EDIT ENTER button to save it and move to the next digit.

0 0 0 0
SETTING

5 . The Configuration Menu will be displayed.

> BUMP CAL CYLINDER
SETTING

6 . Press BUMP ▼ to scroll to DATE.

7 . Press and release EDIT ENTER. The Date/Time menu will display.

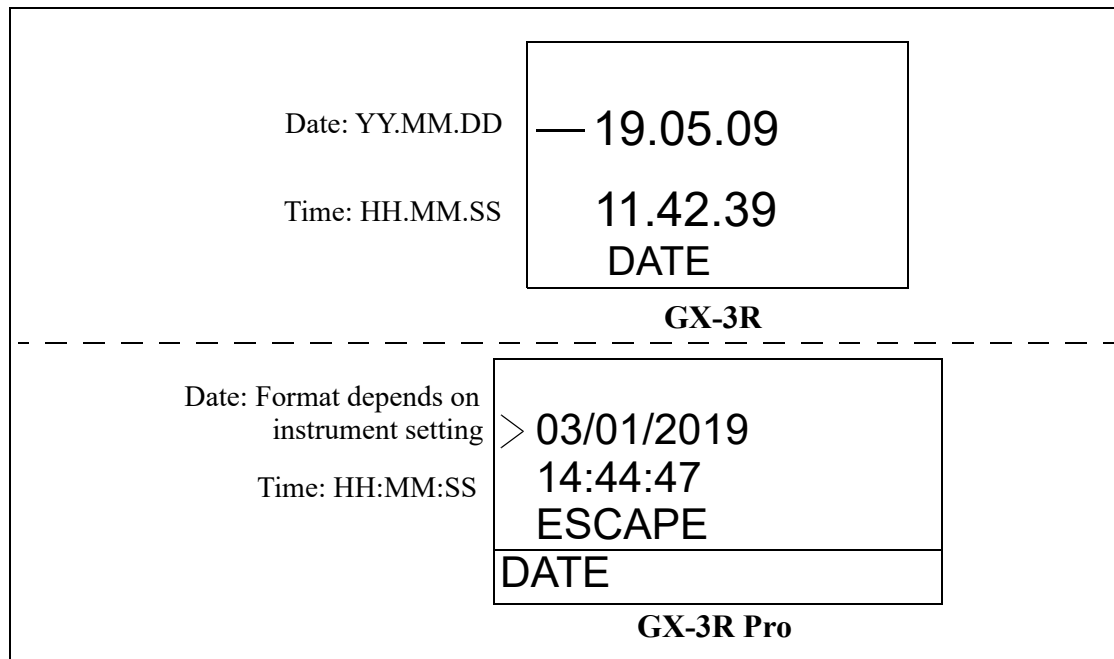

8 . Use BUMP ▼ and CAL ▲ to scroll to the date or the time.

9 . Press and release EDIT ENTER to enter the screen.

10 .Use BUMP ▼ and CAL ▲ to change a value. Press and release EDIT ENTER to save the change and move to the next value. When the last change is saved, DECISION will appear. The SDM-3R returns to the Configuration Menu.

11 .In the Date/Time menu, scroll to ESCAPE and press and release EDIT ENTER to return to the Configuration Menu.

12 .To exit the Configuration Menu and return to the main screen, scroll to ESCAPE and press and release EDIT ENTER.

Password

If Password is set to on, a password will be required to enter the Configuration Menu. If Password is set to off (factory setting), no password is required to enter the Configuration Menu.

NOTE: All screens in this section are for the GX-3R Pro. Your GX-3R screens will be different.

1 . Press the POWER button to turn on the SDM-3R.

2 . Install the GX-3R (Pro) into the SDM-3R's instrument cradle. Be sure the yellow lever is up for a GX-3R and down for a GX-3R (Pro).

3 . Close the red door. The GX-3R (Pro) will automatically turn on and connect to the SDM-3R.

CH4	%LEL	CO	ppm	H2S	ppm
	50		50		25.0
O2	%	CO2	vol%		
	12.0		2.50		
TRANSMIT					

4 . Press the EDIT ENTER button. If Password is set to on (factory setting is off), you will be prompted for a password. Use BUMP ▼ and CAL ▲ to adjust a digit and the EDIT ENTER button to save it and move to the next digit.

0 0 0 0
SETTING

5 . The Configuration Menu will be displayed.

> BUMP CAL CYLINDER
SETTING

6 . Press BUMP ▼ to scroll to PASSWORD.

7 . Press and release EDIT ENTER. The Password menu will display.

> ON/OFF PASSWORD ESCAPE
PASSWORD

8 . To turn the password on or off:

- Use BUMP ▼ and CAL ▲ to scroll to ON/OFF.
- Press and release EDIT ENTER. The current setting displays and flashes.
- Use BUMP ▼ and CAL ▲ to change the setting.
- Press and release EDIT ENTER to save the change. DECISION appears and the SDM-3R returns to the Password Menu.

- 9 . To set the password:
 - a. Use BUMP ▼ and CAL ▲ to scroll to PASSWORD.
 - b. Press and release EDIT ENTER. The current setting displays and flashes.
 - c. Use BUMP ▼ and CAL ▲ to adjust the first digit.
 - d. Press EDIT ENTER to save the value and move to the next digit.
 - e. When you press EDIT ENTER to save the last digit, DECISION appears and the SDM-3R returns to the Password Menu.
- 10 .To return to the Configuration Menu, scroll to ESCAPE and press and release EDIT ENTER.
- 11 .To exit the Configuration Menu and return to the main screen, scroll to ESCAPE and press and release EDIT ENTER.

Chapter 5: Detailed Parameter and LAN Setup in PC Program

Use the PC program to:

- make detailed parameter changes to the SDM-3R (pg. 43)
- set up the LAN connectivity, optional (pg. 42)

Installing the SDM-3R PC Controller Program

NOTE: The PC Program is not required for Standalone operation but is needed to define detailed parameters and to set up the LAN connectivity.

1. Launch Windows®.
2. Exit from all applications and open windows.
3. Go to www.rkiinstruments.com/sdm3r.
4. Click on the **Download** tab.
5. Click the **SDM-3R PC Controller Software** link.
6. A .zip file will begin to download. Save the .zip file.
7. Extract the contents of the .zip file.
8. Double click the setup.exe file.
9. The SDM-3R Docking Station PC Controller InstallShield Wizard comes up to guide you through installation. Follow the InstallShield Wizard instructions.
10. A Device Driver Window will appear prompting you to install necessary drivers. You cannot continue the installation without installing the drivers.

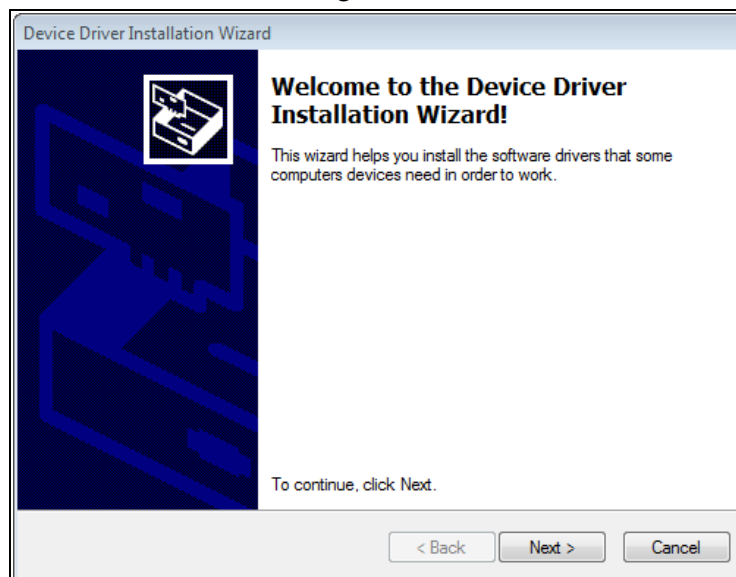

Figure 15: Device Driver Installation

11. Click **Next** to install the drivers. The Wizard will find the appropriate drivers.

12. Click **Finish** once the drivers are successfully installed.

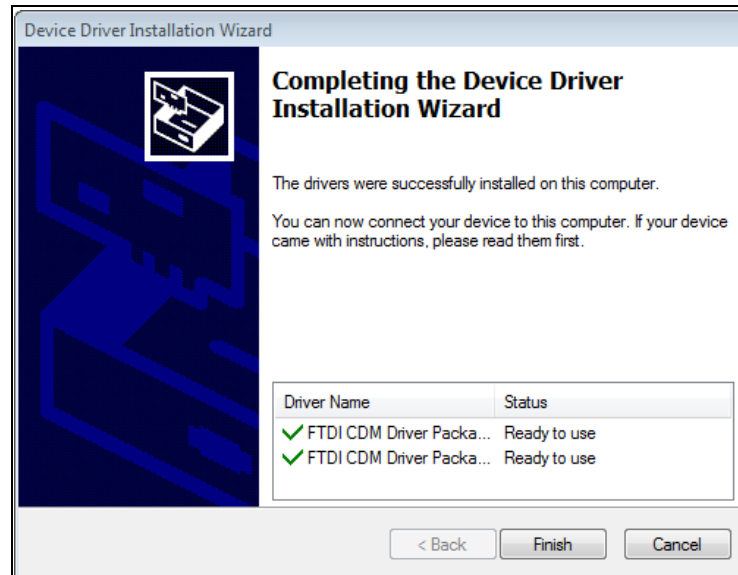

Figure 16: Finish Device Driver Installation

13. To complete the driver installation, ensure that your docking station is connected to your computer.

14. Turn on the docking station pressing the POWER button.

15 .The first time an SDM-3R is turned on after being connected to the computer, the SDM-3R needs some time to be recognized by the computer. The status bar will indicate that the drivers are being configured and will alert you when the SDM-3R is ready to use.

Making Detailed Parameter Changes in SDM Window

The PC Program allows you to change several parameters that affect the operation of the SDM-3R in Standalone Mode that are not accessible through the SDM-3R user interface. The parameters that affect standalone operation but are only accessible using the PC Program are:

- Data Logger:
 - set up the SDM-3R to automatically download the GX-3R (Pro)'s logger data to a USB drive every time it's turned on or at an interval
 - enable or disable manual downloading of the GX-3R (Pro)'s logger data to a USB drive
- Power Saving: select how much time goes by before the GX-3R (Pro) is automatically turned off after a successful test and after the last button push
- Automatic Execution: set up what day(s)/time the SDM-3R will automatically bump test, calibrate, or alarm check an installed GX-3R (Pro)

NOTE: These parameters do not need to be edited in order for the SDM-3R to function properly. These parameters allow you to edit features or initiate certain operations that cannot be accessed using the SDM-3R's Config Menu.

- 1 . Click **Start** on the Windows Icon Tray, then select **Programs/SDM-3R**. You may also double click the shortcut created on your desktop. The PC Program is launched and the main program window appears.
- 2 . If you are starting the software for the first time, a message window appears informing you that a database has been created. Click **OK** in that window.
- 3 . Connect the SDM-3R to a PC using the SDM-3R's PC port and a Type A to Type B USB cable.
- 4 . Connect the AC adapter to the SDM-3R and to an AC wall socket.
- 5 . Press the POWER button to turn on the SDM-3R. When the SDM-3R connects to the PC Program, it appears in the SDM-3R/GX-3R Pro Display Area.

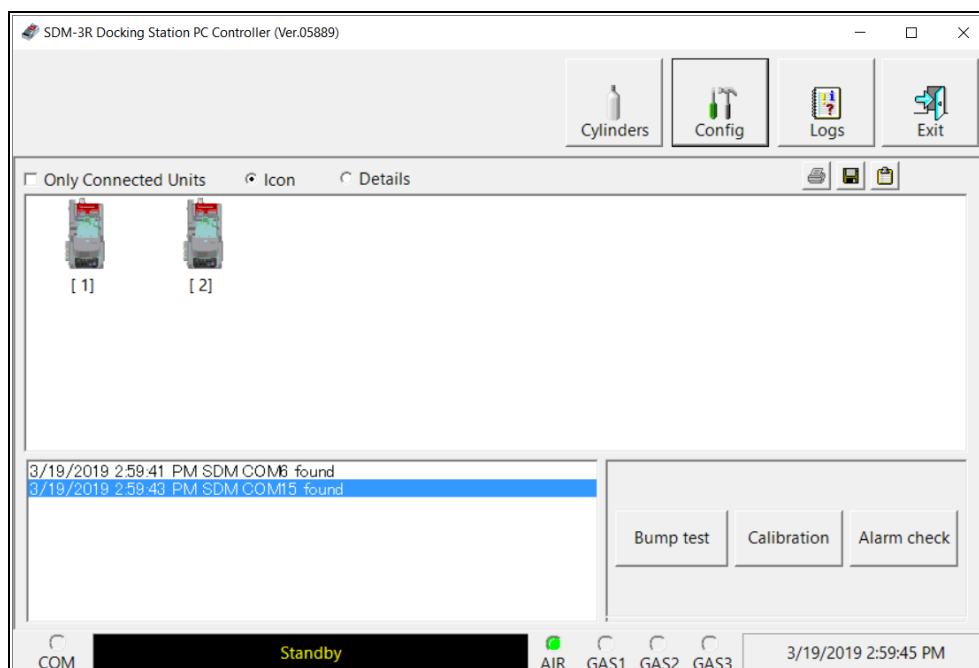

Figure 17: SDM-3Rs Connected to PC Program

6 . Right click on the SDM-3R icon and select **Open (SDM)S**. The SDM Window appears.

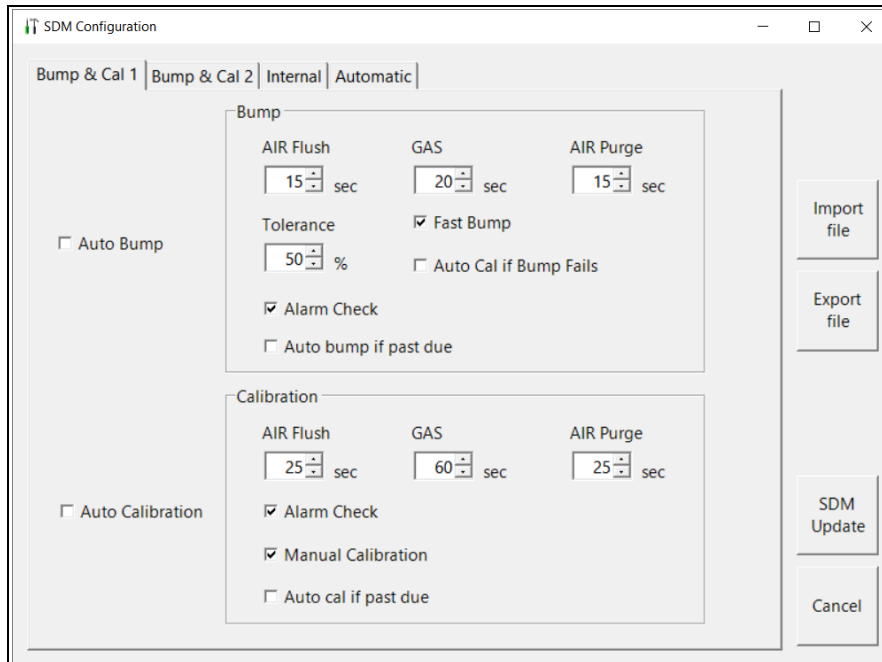

Figure 18: SDM Window

7 . Click the **Bump & Cal 2** tab.

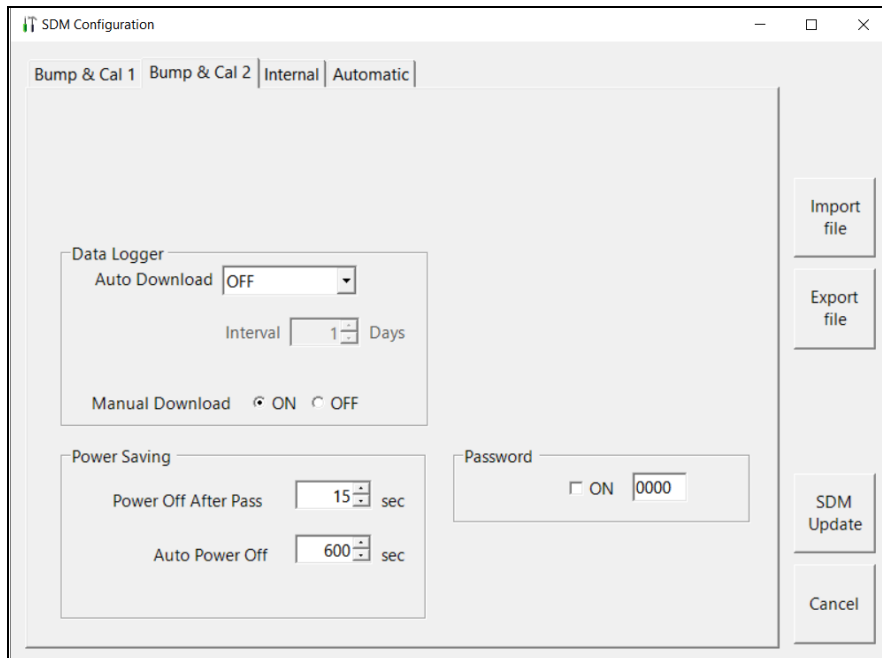

Figure 19: SDM Window, Bump & Cal 2 Tab

8 . Make the desired changes in the **Data Logger** section.

Auto Download

- **OFF** (factory setting): No data download to a USB drive will be performed when a GX-3R (Pro) is connected to the SDM-3R.

- **Every Time:** A data download to a USB drive will automatically occur every time a GX-3R (Pro) is connected to the SDM-3R.
- **Interval:** A data download to a USB drive is performed once per interval. If this option is selected, the **Auto Download Interval** parameter becomes active and needs to be set. The **Interval** parameter is described below.

Interval

- The length of time, in days, that will pass before data is automatically downloaded from a GX-3R (Pro) if **Auto Download** is set to **Interval**. If the GX-3R (Pro) is connected to an SDM-3R before the interval has passed, a data download will not automatically occur. The **Interval** can be set anywhere from **1** to **60** days. The factory setting is **1** day.

Manual Download

- **On** (factory setting): GX-3R (Pro) data can be manually downloaded to a USB drive using the COPY button.
- **Off:** GX-3R (Pro) data cannot be manually downloaded to a USB drive using the COPY button.

9. Make the desired changes in the **Power Saving** section.

Power Off After Pass

- The length of time that will pass after a successful bump test, calibration, or alarm check before the docking station will automatically shut off the GX-3R (Pro). It is defined in seconds with a maximum setting of **99,999** seconds. The factory setting is **15** seconds. If this parameter is set to **0** seconds, the GX-3R (Pro) will not be turned off after a successful bump test, calibration, or alarm check.

Auto Power Off

- The length of time that will pass after the last operation is finished before the docking station will automatically shut off the GX-3R (Pro). If a successful bump test, calibration, or alarm check is performed, the docking station will automatically shut off the GX-3R (Pro) in the time defined in **Power Off After Pass** regardless of the **Auto Power Off** setting. It is defined in seconds with a maximum setting of **99,999** seconds. The factory setting is **600** seconds.

10 .Click the **Automatic** tab.

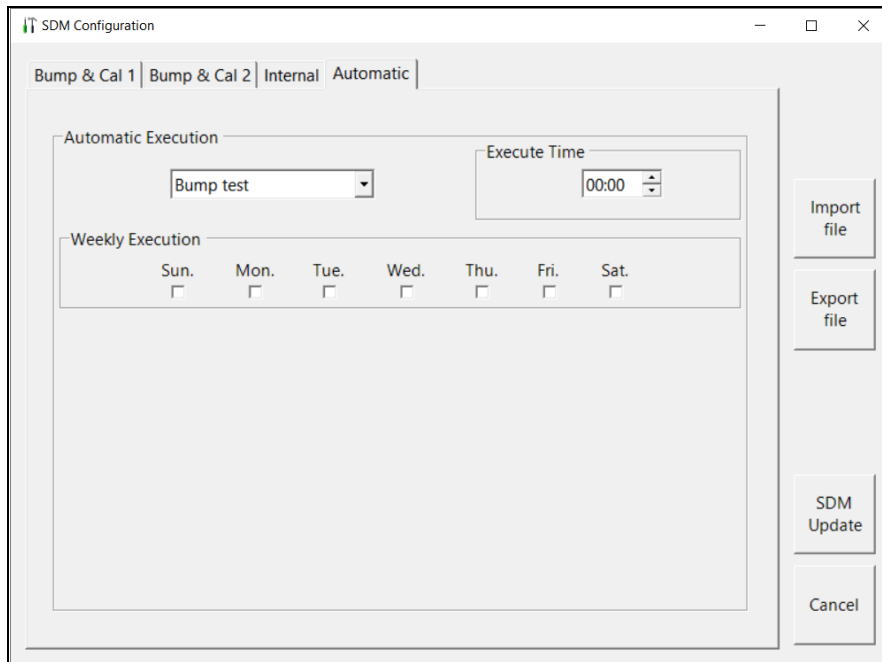

Figure 20: SDM Window, Automatic Tab

- 11 .Make the desired changes to the automatic procedures. You can set up a bump test, calibration, or alarm check to automatically occur at a specific time on the desired day(s). If a GX-3R (Pro) is installed in an SDM-3R at the specified day/time, the SDM-3R will turn on the GX-3R (Pro), perform the test, then turn off the GX-3R (Pro).
- 12 .Click **SDM Update** and **Yes** in the window that appears to save the changes to the SDM-3R.

Setting Up LAN Connectivity

Connecting the SDM-3R to a LAN network allows you to download test data from the SDM-3R's memory into the PC Program using a computer connected to the same LAN network. This can be convenient if your SDM-3Rs are spread out throughout the building or if you do not want to copy data to a USB drive. This section describes how to connect your SDM-3R(s) to a network port and set up the LAN connectivity. "Chapter 8: Importing and Viewing Data" on page 68 describes how to import data once the LAN connectivity is set up.

DHCP Network

NOTE: For users with a DHCP network, if the SDM-3R lost power or the network went down after you set up the LAN connectivity, you may need to set up the LAN connectivity again. A new IP address may have been assigned to the SDM-3R when power was restored or when the network came back up.

- 1 . Click **Start** on the Windows Icon Tray, then select **Programs\SDM-3R**. You may also double click the shortcut created on your desktop. The PC Program launches and the main program window appears.

- 2 . If you are starting the software for the first time, a message window appears informing you that a database has been created. Click **OK** in that window.
- 3 . Connect the SDM-3R to the network port closest to its installed location using the SDM-3R's LAN port and an Ethernet cable. Be sure to connect all SDM-3Rs you plan on having connected to the LAN network. There is no need to connect 1 at a time to perform the setup. Be sure the SDM-3Rs are in their intended installation locations. They do not need to be close to the PC being used for setup.
- 4 . Connect the AC adapter to the SDM-3R and to an AC wall socket.
- 5 . Press the POWER button to turn on the SDM-3R.
- 6 . Click the **Logs** button in the PC Program.

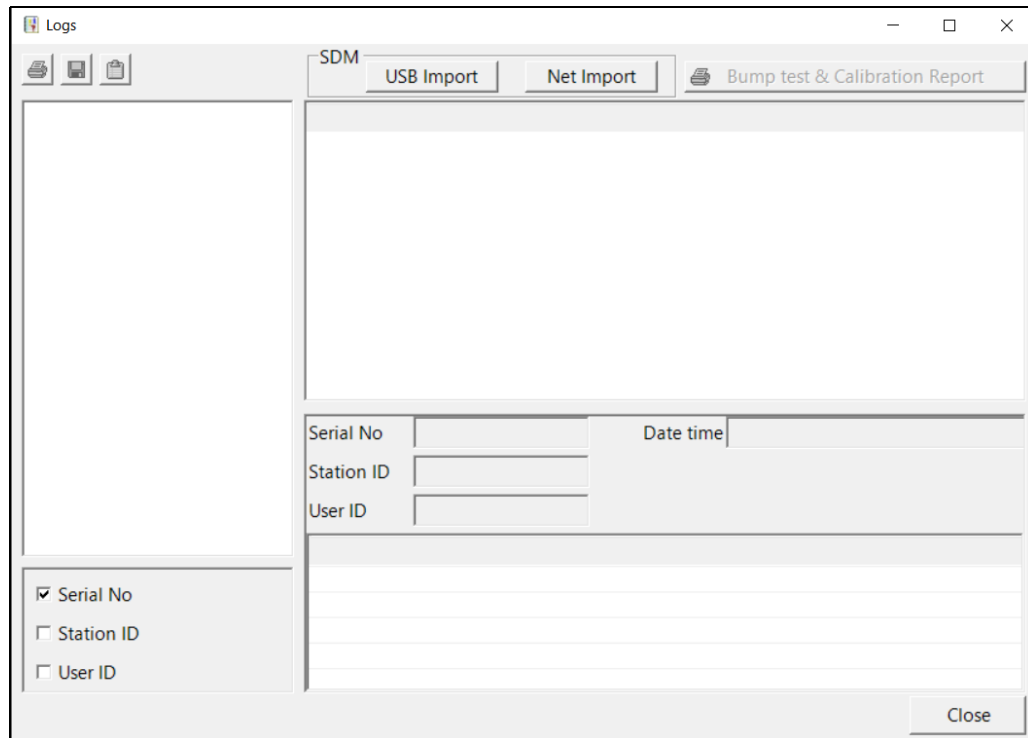

Figure 21: Logs Window

7 . Click **Net Import**.

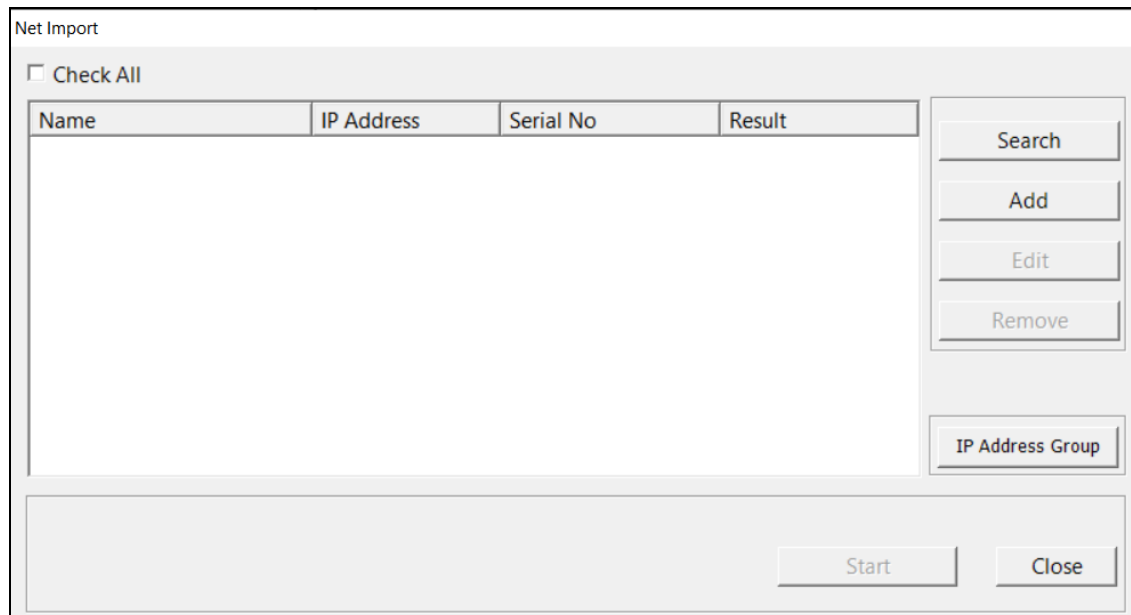
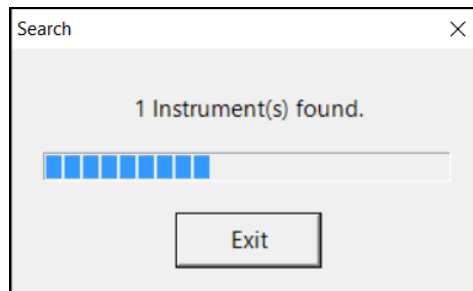

Figure 22: Net Import Window

8 . Click **Search**. The program will find any SDM-3Rs that are connected to the same network as the PC you are using.



- 9 . Once the program completes the search, the found SDM-3R(s) appear in the Net Import Screen with their serial number(s) and assigned IP address(es).

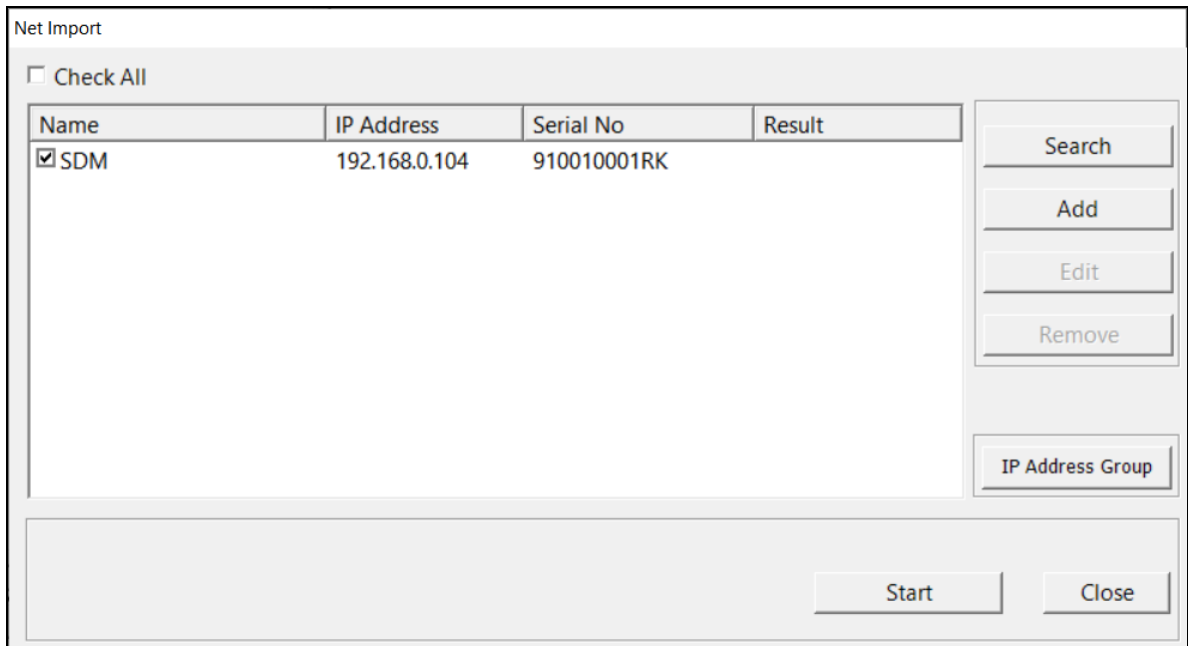

Figure 23: Net Import Window with Found SDM-3Rs

- 10 .If you would like to rename an SDM-3R to describe its location or some other defining parameter in more detail, click on the desired SDM-3R and then click **Edit**. Type in the desired name for the SDM-3R. **DO NOT CHANGE THE IP ADDRESS FIELD.**

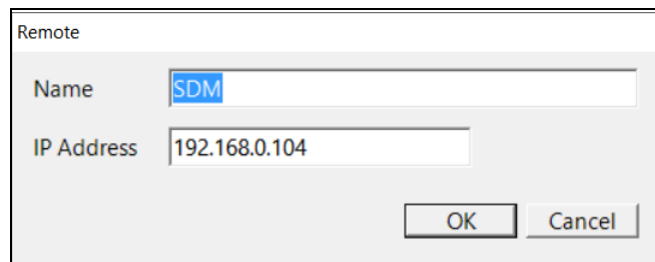

Figure 24: Edit Window

- 11 .Click **Close** in the Net Import Window.
- 12 .Exit the SDM-3R program by clicking the **Exit** button.

Non-DHCP Networks

NOTE: The LAN connectivity must be set up one SDM-3R at a time. You cannot have multiple SDM-3Rs connected to your PC while performing the LAN connectivity setup procedure.

- 1 . Click **Start** on the Windows Icon Tray, then select **Programs/SDM-3R**. You may also double click the shortcut created on your desktop. The PC Program is launched and the main program window appears.
- 2 . If you are starting the software for the first time, a message window appears informing you that a database has been created. Click **OK** in that window.
- 3 . Connect the SDM-3R to a PC using the SDM-3R's PC port and a Type A to Type B USB cable. The SDM-3R does not need to be installed in its intended location or connected to the network in order to set up the LAN connectivity. It just needs to be connected to the PC Program.
- 4 . Connect the AC adapter to the SDM-3R and to an AC wall socket.
- 5 . Press the POWER button to turn on the SDM-3R.
- 6 . Right click on the SDM-3R icon and select **Open (SDM)S**. The SDM Window appears.

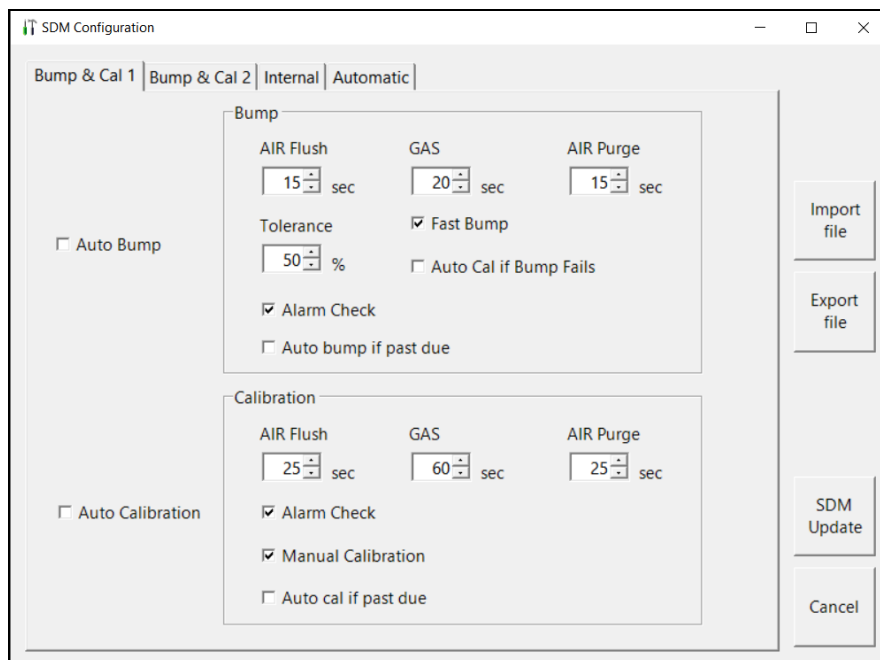

Figure 25: SDM Window

7 . Click the **Internal** tab.

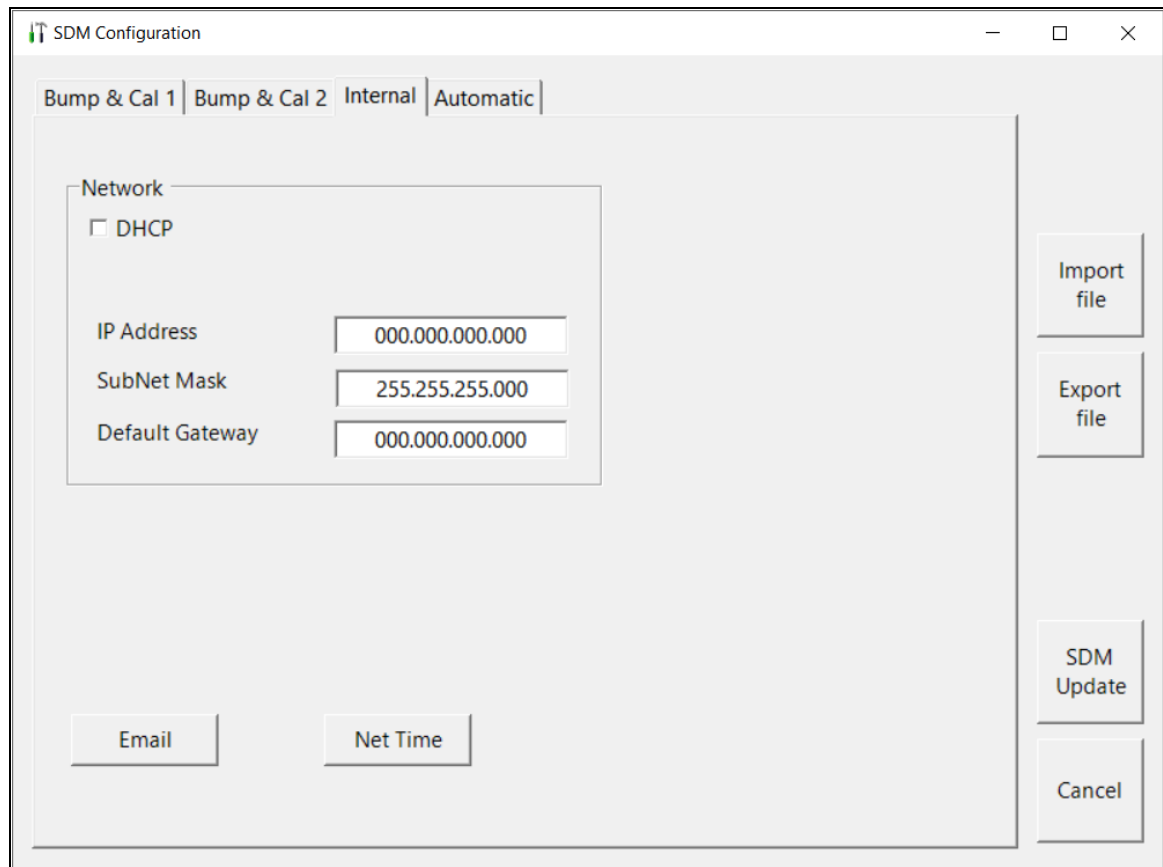

Figure 26: Internal Tab

8 . Be sure **DHCP** is deselected.

9 . Enter an IP Address, SubNet Mask, and Default Gateway for the SDM-3R.

10 .Click **SDM Update** and click **Yes** in the window that comes up.

11 .Turn the SDM-3R off and then on again before continuing.

12 .Click the **Logs** button.

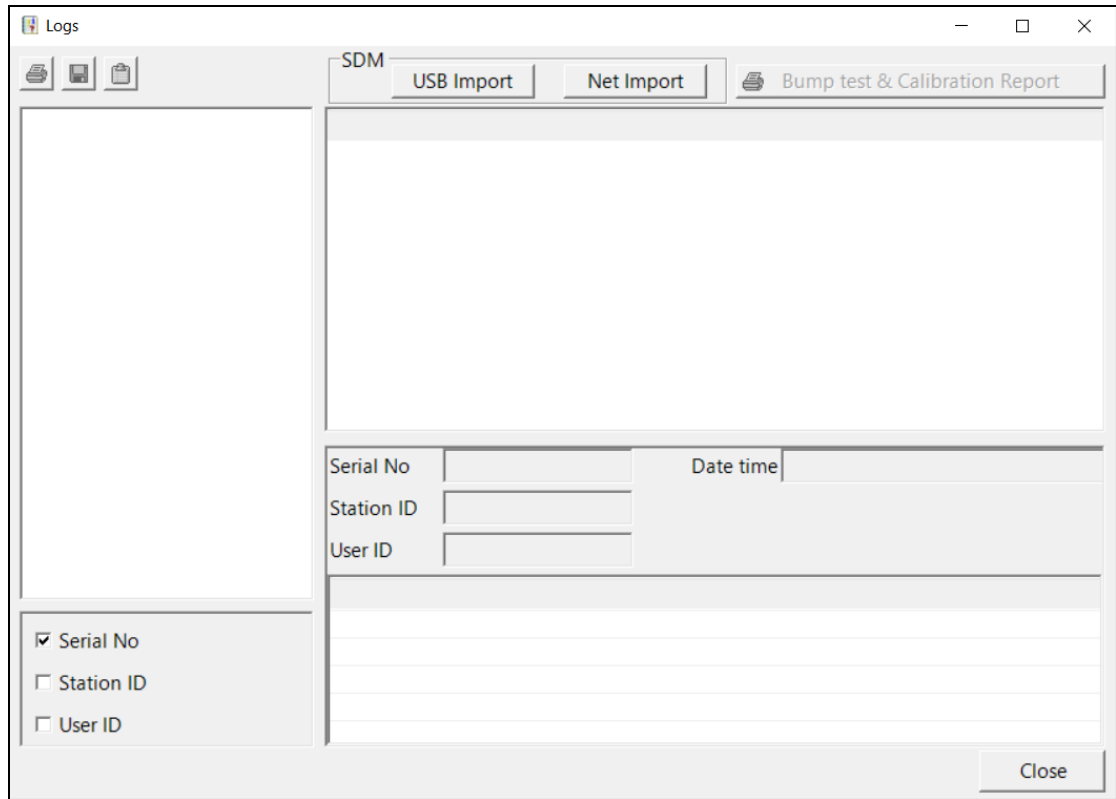

Figure 27: Logs Window

13 .Click **Net Import**.

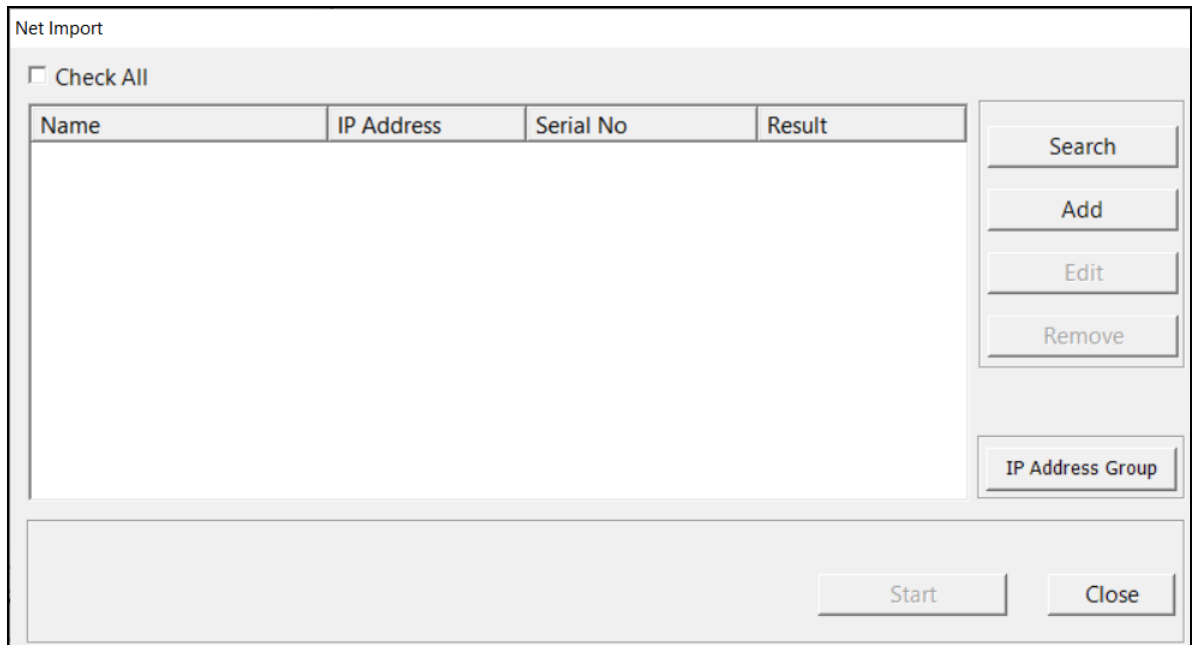
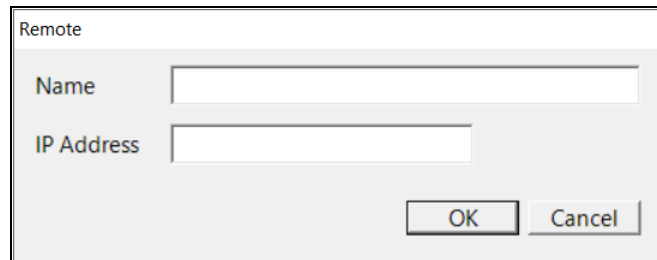

Figure 28: Net Import Window

14 .Click **Add**.



The 'Remote' window is a simple dialog box with a light gray background. It contains two text input fields: 'Name' and 'IP Address'. Below these fields are two buttons: 'OK' and 'Cancel'.

Figure 29: Add Window

15 .Enter a name for the SDM-3R and enter the IP Address that you assigned to the SDM-3R in the Internal Tab of the SDM Configuration Window.

16 .Click **OK**. The newly added SDM-3R will appear.

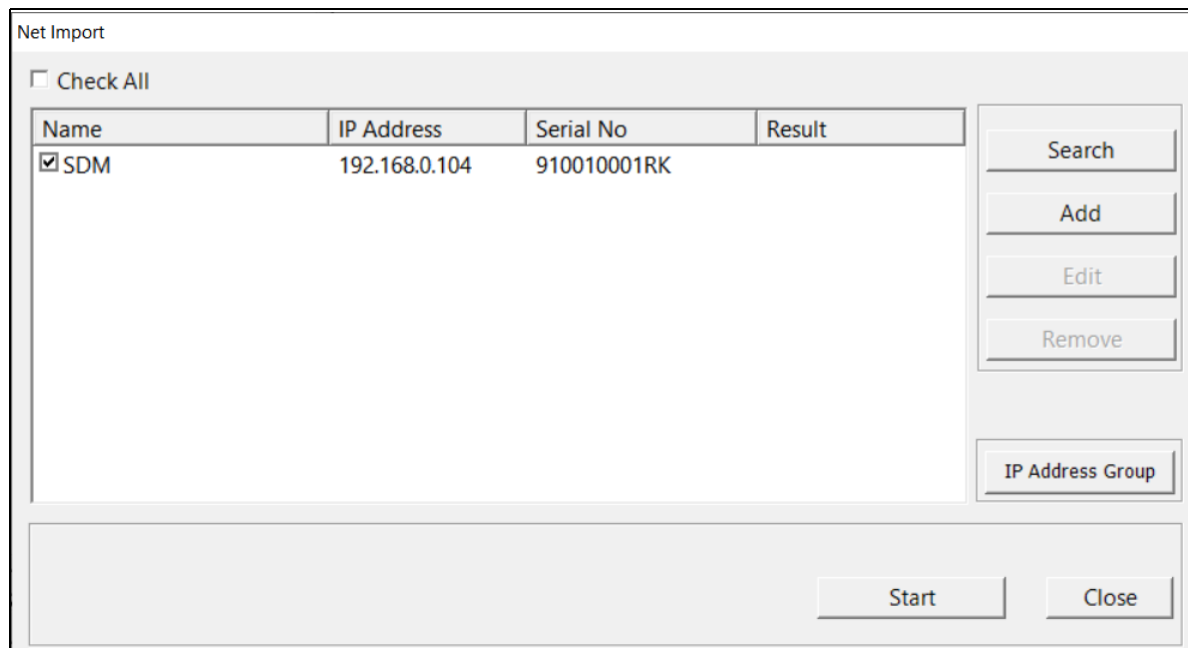

The 'Net Import' window features a 'Check All' checkbox at the top left. Below it is a table with four columns: 'Name', 'IP Address', 'Serial No', and 'Result'. The table contains one row with a checked checkbox, 'SDM', '192.168.0.104', and '910010001RK'. To the right of the table are buttons for 'Search', 'Add', 'Edit', and 'Remove'. Below these is an 'IP Address Group' button. At the bottom right are 'Start' and 'Close' buttons.

Name	IP Address	Serial No	Result
<input checked="" type="checkbox"/> SDM	192.168.0.104	910010001RK	

Figure 30: Net Import Window with Manually Added SDM-3R

17 .Disconnect the USB cable from the SDM-3R, turn off the SDM-3R, and unplug the AC adapter from the wall.

18 .Move the SDM-3R to its intended installation location and plug the AC adapter into the wall and turn on the SDM-3R.

19 .Connect the SDM-3R to a network port using the SDM-3R's LAN port and an Ethernet cable.

20 .Repeat steps 3 - 19 for any additional SDM-3Rs.

21 .Click **Close** in the Net Import Window.

22 .Exit the SDM-3R program by clicking the **Exit** button.

Chapter 6: Operation

Overview

The SDM-3R is capable of performing bump tests, calibrations, and alarm checks on the GX-3R (Pro). It can also charge the rechargeable Li-ion battery pack in the GX-3R (Pro). This chapter describes procedures for using the docking station to bump test, calibrate, alarm check, download instrument logger data to a USB drive, and recharge GX-3R (Pro)s.

NOTE: When the GX-3R (Pro) is connected to the SDM-3R, the GX-3R (Pro)'s date and time are automatically updated to the SDM-3R's current date and time. Ensure that the SDM-3R's date and time are correct before connecting a GX-3R (Pro).

Automatically Initiated Tests and Data Download

Tests

There are two types of automatic tests:

- 1 . Bump test, calibration, or alarm check automatically starts at GX-3R (Pro) connection (set in SDM-3R Config Menu)

OR

- 2 . GX-3R (Pro) is automatically turned on at a specific date/time and a bump test, calibration, or alarm check is performed (set in PC Program's SDM Window)

For each option, no user involvement is needed to start the test and the test progresses as described in the appropriate section below. For bump testing and calibration, the calibration cylinders need to be connected to the appropriate fittings and the cylinder assignments need to be set up appropriately.

Data Download

An automatic data download (set in PC Program's SDM Window) automatically downloads a connected GX-3R (Pro)'s logged data. A USB drive must be inserted in the USB port on the front of the SDM-3R in order for the automatic data download to occur.

Turning on an SDM-3R System

NOTE: All screens in this section are for the GX-3R Pro. Your GX-3R screens will be different.

Do the following to turn on the SDM-3R and establish a connection with a GX-3R (Pro):

- 1 . Connect the AC adapter to the SDM-3R and to an AC wall socket.
- 2 . Press the POWER button to turn on the SDM-3R. The SDM-3R's CHARGE LED will be solid green if it is operating properly or solid red if there is a system failure. The COPY LED will indicate how much storage space is left in the SDM-3R.

- 3 . Install the GX-3R (Pro) into the SDM-3R's instrument cradle. Be sure the yellow lever is up for a GX-3R and down for a GX-3R (Pro).
- 4 . Close the red door. The GX-3R (Pro) will automatically turn on and connect to the SDM-3R.

CH4	%LEL	CO	ppm	H2S	ppm
	50		50		25.0
O2	%	CO2		vol%	
	12.0			2.50	
TRANSMIT					

- 5 . Repeat step 1 - step 4 for any additional SDM-3Rs and GX-3R (Pro)s.
- 6 . When the GX-3R (Pro) is connected to the SDM-3R, the GX-3R (Pro)'s date and time are automatically updated to the SDM-3R's current date and time.
- 7 . If an automatic test is set up to occur, it will start as soon as the GX-3R (Pro) is connected to the SDM-3R.

Bump Testing

When a bump test is performed, the SDM-3R performs a fresh air adjustment on a GX-3R (Pro) and then applies calibration gas to the instrument. The docking station then analyzes the response and determines if the instrument passed the bump test based on the bump test check tolerance setting (see pg. 27). If the automatic calibration parameter is set to on (see pg. 27), then the SDM-3R will automatically perform a calibration if the bump test fails.

NOTE: All screens in this section are for the GX-3R Pro. Your GX-3R screens will be different.

Do the following to perform a bump test:

- 1 . Turn on the SDM-3R system as described on pg. 55.
- 2 . Confirm that the bump test parameters are set to the desired values as described on pg. 26.
- 3 . Confirm that the gas inlet parameters are appropriately assigned as described on pg. 34.
- 4 . Verify that the appropriate calibration gas cylinders are connected to the gas fittings on the left side of the SDM-3R. See pg. 23 for calibration gas cylinder options and calibration gas connection procedures.

- 5 . If you are using a CO₂ scrubber instead of a N₂ cylinder to zero the CO₂ sensor:
 - a. Remove the tubing from the side of the scrubber that does not have an arrow pointing to it.
 - b. Connect the tubing to the SDM-3R gas inlet that is assigned to N₂ (generally GAS2). Be sure the arrow on the filter is pointing toward the gas inlet.

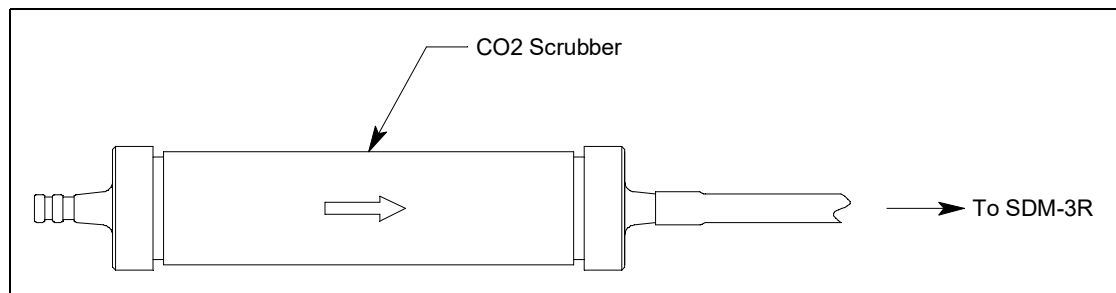

Figure 31: Connecting CO₂ Scrubber to SDM-3R Gas Inlet

- 6 . Press **BUMP ▼** to initiate a bump test.

If you wish to cancel the bump test, press and hold **BUMP ▼** until the screen shows **CANCEL**.

NOTE: A bump test cannot be started if a GX-3R is installed with the yellow lever down.

- 7 . Throughout the bump test, the GX-3R (Pro)'s screen will display the current gas readings along with the pass/fail status of a bump test or automatic calibration. If **FAST BUMP** is set to **On**, an "F" appears in the bottom right corner during testing.
- 8 . If at any point during the bump test the gas flow to the GX-3R (Pro) becomes too low, the bump test will be aborted and the screen will indicate a flow failure.

CH4	%LEL	CO	ppm	H2S	ppm
- - -	- - -	- - -	- - -	- - -	- - -
O2	%	CO2		vol%	
- - -	- - -	-		- - -	
FLOW NG					

If a flow failure occurs, confirm all tubing connections are correct, that all lines are clear, and that the GX-3R (Pro) is correctly installed in the SDM-3R.

Press and release **EDIT ENTER** to return to the main screen.

- 9 . A pre-sample flush will begin. The SDM-3R will apply fresh air to the GX-3R (Pro) for the time defined by the **AIR FLUSH** bump test parameter.

NOTE: If the GX-3R (Pro) was not on for 40 seconds before the bump test was initiated, air will flow until the GX-3R (Pro) has been on for 40 seconds regardless of the **AIR FLUSH** bump test parameter setting.

- 10 .The SDM-3R will perform a fresh air adjustment on the instrument.
- If the air adjustment is successful, the SDM-3R will continue as described in step 11 below.
 - If one or more of the sensors fails the fresh air adjustment, the SDM-3R will abort the bump test and will not apply calibration gas. If this happens, the Unit Tab will indicate which channels passed and failed the fresh air adjustment. In the following example, the O₂ channel failed the fresh air adjustment.

CH4	%LEL	CO	ppm	H2S	ppm
P		P		P	
O2	%	CO2		vol%	
F				-	
AIR CAL					

In this case, continue to step 17.

- 11 .The SDM-3R will then apply calibration gas in the order of the gas inlets (GAS1, GAS2, GAS3). If the test requires a cylinder change, the LCD will prompt you to change the cylinder but the SDM-3R's pump will keep running.

NOTE: N₂ is always applied before CO₂, regardless of its inlet assignment.

- 12 .The SDM-3R will analyze the results after the end of each gas application. If the bump test fails and AUTO CAL is set to ON, the gas will keep flowing and a calibration will automatically begin. Calibration gas will continue to be applied so that the total gas application time is the time defined by the GAS TIME calibration parameter. This time includes the time that the GX-3R (Pro) was being bump tested. If the GAS TIME **calibration parameter** is set to 90 seconds and the GAS TIME **bump test parameter** is set to 30 seconds, the GX-3R (Pro) will sample gas for an additional 60 seconds to bring the total exposure time to 90 seconds.

NOTE: If the CO₂ sensor is calibrated after a failed bump test, N₂ gets reapplied first to get an accurate zero.

- 13 .A post-sample purge will begin.
- 14 .If the ALARM CHECK bump test parameter is set to ON, an alarm check will begin. The buzzer will sound, the LEDs will turn on for a few seconds, and the SDM-3R will determine if these actions were completed successfully.
- 15 .Once the bump test is over, the LCD will display the test results. The BUMP ▼ and CAL ▲ LED (if applicable) will be green if all channels passed or red if any channels failed. The EDIT ENTER LED will be green for a passed alarm check or red for a failed alarm check. The LEDs will stay on until you press EDIT ENTER and will remain on even if you turn the GX-3R (Pro) off.

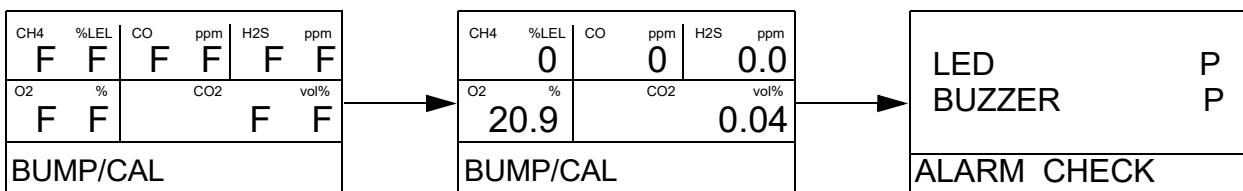

- 16 .Press EDIT ENTER to return to the main screen.
- 17 .To perform any other operations, press BUMP ▼, CAL ▲, or BUMP ▼ and EDIT ENTER.

18 .To turn the GX-3R (Pro) off:

If the bump test was successful, the GX-3R (Pro) will shut off in the time period defined by the Power Off After Pass parameter in the PC Program's SDM Window. If the bump test failed, the GX-3R (Pro) will shut off in the time period defined by the Auto Power Off parameter in the PC Program's SDM Window.

To turn off the GX-3R (Pro) before it is automatically turned off, press the EDIT ENTER and POWER buttons.

- 19 .The results of the bump test, calibration (if applicable), and alarm check will be stored in the SDM-3R.
- 20 .Release the tab on the red door.
- 21 .Remove the GX-3R (Pro) from the SDM-3R.
- 22 .Repeat step 1 - step 21 for any additional GX-3R (Pro)s.
- 23 .If you are using a CO₂ scrubber instead of a N₂ cylinder to zero the CO₂ sensor:
 - a. Remove the scrubber from the gas inlet.
 - b. Reattach the tubing to the open end of the scrubber.

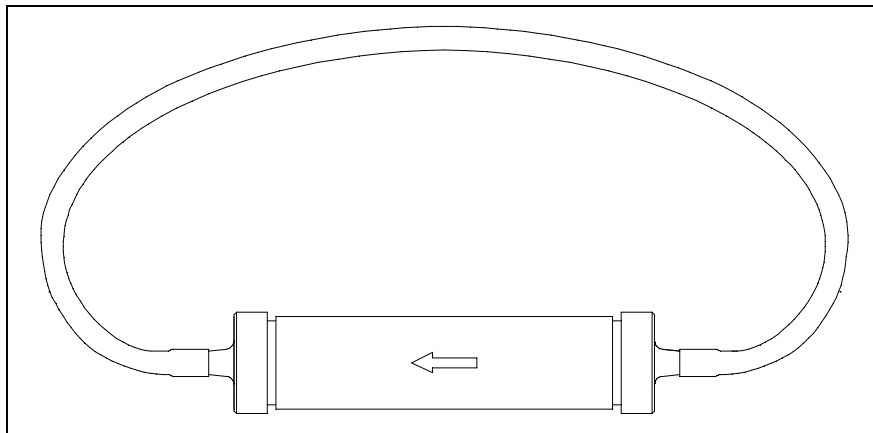

Figure 32: Reattaching CO₂ Scrubber Tubing for Storage

Calibration

When a calibration is performed, the docking station performs a fresh air adjustment on a GX-3R (Pro) and then applies calibration gas to the instrument. The docking station analyzes the calibration results and determines if the instrument passed the calibration.

NOTE: All screens in this section are for the GX-3R Pro. Your GX-3R screens will be different.

To perform a calibration on a GX-3R (Pro):

- 1 . Turn on the SDM-3R system as described on pg. 55.
- 2 . Confirm that the calibration parameters are set to the desired values as described on pg. 31.
- 3 . Confirm that the gas inlet parameters are appropriately assigned as described on pg. 34.
- 4 . Verify that the appropriate calibration gas cylinders are connected to the gas fittings on the left side of the SDM-3R. See pg. 23 for calibration gas cylinder options and calibration gas connection procedures.
- 5 . If you are using a CO₂ scrubber instead of a N₂ cylinder to zero the CO₂ sensor:
 - a. Remove the tubing from the side of the scrubber that does not have an arrow pointing to it.
 - b. Connect the tubing to the SDM-3R gas inlet that is assigned to N₂ (generally GAS2). Be sure the arrow on the filter is pointing toward the gas inlet.

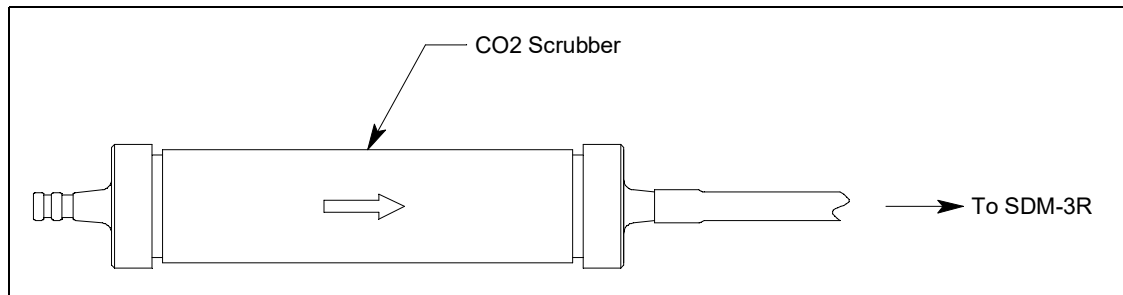

Figure 33: Connecting CO₂ Scrubber to SDM-3R Gas Inlet

- 6 . Press CAL ▲ to initiate a calibration.

If you wish to cancel the calibration, press and hold CAL ▲ until the screen shows CANCEL.

NOTE: A calibration cannot be started if a GX-3R is installed with the yellow lever down.

- 7 . Throughout the calibration, the GX-3R (Pro)'s screen will display the current gas readings along with the pass/fail status of the calibration.

- 8 . If at any point during the calibration the gas flow to the GX-3R (Pro) becomes too low, the calibration will be aborted and the screen will indicate a flow failure.

CH4	%LEL	CO	ppm	H2S	ppm
-	-	-	-	-	-
O2	%	CO2		vol%	
-	-	-		-	
FLOW NG					

If a flow failure occurs, confirm all tubing connections are correct, that all lines are clear, and that the GX-3R (Pro) is correctly installed in the SDM-3R.

- 9 . A pre-sample flush will begin. The SDM-3R will apply fresh air to the GX-3R (Pro) for the time defined by the AIR FLUSH calibration parameter.

NOTE: If the GX-3R (Pro) was not on for 40 seconds before the bump test was initiated, air will flow until the GX-3R (Pro) has been on for 40 seconds regardless of the AIR FLUSH calibration parameter setting.

- 10 .The SDM-3R will perform a fresh air adjustment on the GX-3R (Pro).
- If the air adjustment is successful, the SDM-3R will continue as described in step 11 below.
 - If one or more of the sensors fails the fresh air adjustment, the SDM-3R will abort the calibration and will not apply calibration gas. The LCD will indicate which channels passed and failed the fresh air adjustment. In the following example, the O₂ channel failed the fresh air adjustment. Continue to step 17.

CH4	%LEL	CO	ppm	H2S	ppm
P	P	P	P	P	P
O2	%	CO2		vol%	
F				-	
AIR CAL					

- 11 .The SDM-3R will then apply calibration gas in the order of the gas inlets (GAS1, GAS2, GAS3). If the test requires a cylinder change, the LCD will prompt you to change the cylinder but the SDM-3R's pump will keep running.

NOTE: N₂ is always applied before CO₂, regardless of its inlet assignment.

- 12 .The SDM-3R will analyze the results after the end of each gas application.
- 13 .A post-sample purge will begin.
- 14 .If the ALARM CHECK calibration parameter is set to ON, an alarm check will begin. The buzzer will sound, the LEDs will turn on for a few seconds, and the SDM-3R will determine if these actions were completed successfully.

15 .Once the calibration is over, the LCD will display the test results. The CAL ▲ LED will be green if all channels passed or red if any channels failed. The EDIT ENTER LED will be green for a passed alarm check or red for a failed alarm check. The LED(s) will stay on until you press EDIT ENTER and will remain on even if you turn the GX-3R (Pro) off.

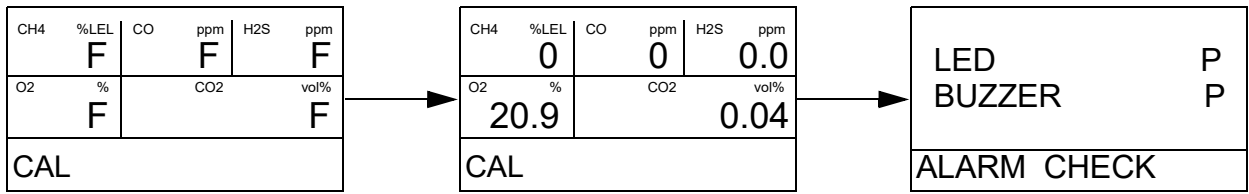

16 .Press EDIT ENTER to return to the main screen.

17 .To perform any other operations, press BUMP ▼, CAL ▲, or BUMP ▼ and EDIT ENTER.

18 .To turn the GX-3R (Pro) off:

If the calibration was successful, the GX-3R (Pro) will shut off in the time period defined by the Power Off After Pass parameter in the PC Program’s SDM Window. If the calibration failed, the GX-3R (Pro) will shut off in the time period defined by the Auto Power Off parameter in the PC Program’s SDM Window.

To turn off the GX-3R (Pro) before it is automatically turned off, press the EDIT ENTER and POWER buttons.

19 .The results of the calibration and alarm check will be stored in the SDM-3R.

20 .Release the tab on the red door.

21 .Remove the GX-3R (Pro) from the SDM-3R.

22 .Repeat step 1 - step 21 for any additional GX-3R (Pro)s.

23 .If you are using a CO₂ scrubber instead of a N₂ cylinder to zero the CO₂ sensor:

- a. Remove the scrubber from the gas inlet.
- b. Reattach the tubing to the open end of the scrubber.

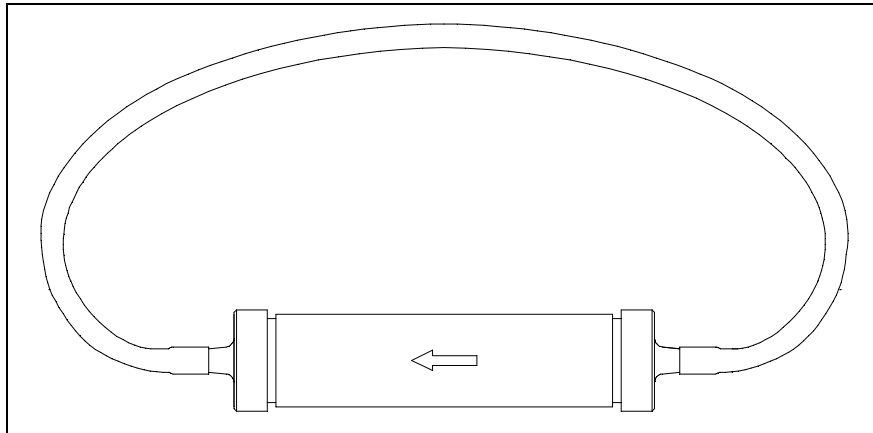

Figure 34: Reattaching CO₂ Scrubber Tubing for Storage

Alarm Check

To perform an alarm check on a GX-3R (Pro):

- 1 . Turn on the SDM-3R system as described in “Turning on an SDM-3R System” on page 55.
- 2 . Press BUMP ▼ and EDIT ENTER to initiate an alarm check.
If you wish to cancel the alarm check, press BUMP ▼ and EDIT ENTER again.
- 3 . The buzzer will sound, the LEDs will turn on for a few seconds, and the SDM-3R will determine if these actions were completed successfully.
- 4 . Once the alarm check is over, the LCD will display the results. The EDIT ENTER LED will be green for a passed alarm check or red for a failed alarm check.
- 5 . Press EDIT ENTER to return to the main screen.
- 6 . To perform any other operations, press BUMP ▼, CAL ▲, or BUMP ▼ and EDIT ENTER.
- 7 . To turn the GX-3R (Pro) off:
If the alarm check was successful, the GX-3R (Pro) will shut off in the time period defined by the Power Off After Pass parameter in the PC Program’s SDM Window. If the alarm check failed, the GX-3R (Pro) will shut off in the time period defined by the Auto Power Off parameter in the PC Program’s SDM Window.
To turn off the GX-3R (Pro) before it is automatically turned off, press the EDIT ENTER and POWER buttons.
- 8 . The results of the alarm check will be stored in the SDM-3R.
- 9 . Release the tab on the red door.
- 10 . Remove the GX-3R (Pro) from the SDM-3R.
- 11 . Repeat step 1 - step 10 for any additional GX-3R (Pro)s.

Downloading/Copying Data to a USB Drive

Downloading GX-3R (Pro) Logger Data

Downloaded logger data is saved to a .dat file. The file contains interval trend, alarm trend, etc. data that was saved in the instrument and that was retrieved during a data download. One .dat file is saved per GX-3R (Pro) and the file name is only the instrument serial number (i.e. 569010102.dat).

- 1 . Turn on the SDM-3R system as described in “Turning on an SDM-3R System” on page 55.

NOTE: The GX-3R (Pro) must be on for instrument data to be downloaded to a USB drive.

- 2 . Insert a USB drive into the USB port on the front of the SDM-3R. The COPY LED will begin to flash.

NOTE: If a USB drive is not installed, then instrument data cannot be downloaded.

- 3 . Press and hold COPY for a few seconds until the COPY LED starts flashing orange, then release.

- 4 . The SDM-3R will begin to download instrument data to the USB drive. The COPY LED will continue to flash orange. If you wish to cancel the data download, press and hold COPY.

NOTE: A data download will take approximately 5 minutes to complete.

- 5 . When the data download is complete, the COPY LED will return to its pre-download color. The data is saved to an instrument specific file with a .dat file extension in a DAT folder.
- 6 . See “Chapter 8: Importing and Viewing Data” on page 68 for instructions to add downloaded files to the PC Program’s database.

Copying Bump Test, Calibration, and Alarm Check Records

See “Specifications” on page 8 for information about how much test data the SDM-3R can save. When the SDM-3R’s memory is full, the oldest record is overwritten when a new record is saved.

One .txt file per GX-3R (Pro) is saved in the SDM-3R memory. The file includes results for all tests done while the GX-3R (Pro) is installed in the SDM-3R. The file name will begin with “SDM3R” and the remainder of the file name will depend on the serial number of the tested GX-3R (Pro) and the date of the most recent testing (i.e. SDM3R569010102160318.txt). The date format is YYMMDD (year, month, day). So multiple GX-3R (Pro)s tested on the same day will have separate files because the serial numbers are different. And the same GX-3R (Pro) tested on different days will only have one file because the file name will be changed after each test to reflect the most recent test date.

- 1 . Press and hold POWER to turn on the SDM-3R.
- 2 . Insert a USB drive into the USB port on the front of the SDM-3R. The COPY LED will begin to flash.

NOTE: If a USB drive is not installed, then downloaded instrument data cannot be saved.

- 3 . Press and hold COPY briefly until the COPY LED turn red, then release.
- 4 . The SDM-3R will copy saved bump test, calibration, and alarm check data to the USB drive.
- 5 . When the copy operation is complete, the COPY LED will return to its pre-copy state. The data is saved to an instrument specific file with a .txt file extension in a DAT folder.
- 6 . See “Chapter 8: Importing and Viewing Data” on page 68 for instructions to add saved files to the PC Program’s database.

Deleting Data from the SDM-3R’s Memory

- 1 . Press and hold POWER to turn on the SDM-3R.
- 2 . Press CAL ▲ and COPY.
- 3 . The COPY LED will turn off.

Chapter 7: Maintenance

Troubleshooting

NOTE: This troubleshooting guide describes SDM-3R problems only. See the GX-3R (Pro) Operator’s Manual for problems you may encounter with the GX-3R (Pro).

Table 9: Troubleshooting the SDM-3R

Symptoms	Probable Causes	Recommended Action
Fresh air adjustment fails	<ul style="list-style-type: none"> The SDM-3R is not in a fresh air environment or the cylinder connected to the AIR fitting is not a zero air cylinder. If a zero air cylinder is used, the calibration cylinder is out of gas. The GX-3R (Pro) is not correctly inserted in the instrument cradle. 	<ol style="list-style-type: none"> Confirm that the SDM-3R is in a fresh air environment or that a zero air cylinder is attached to the AIR fitting. If a zero air cylinder is used, verify that it contains an adequate supply of test sample. If a zero air cylinder is used, check all calibration tubing for leaks or for any bad connections. Check to make sure the GX-3R (Pro) is correctly inserted in the instrument cradle. If the fail condition continues, replace the failed sensor(s) in the GX-3R (Pro). If the difficulties continue, contact RKI Instruments, Inc. for further instruction.
Calibration fails	<ul style="list-style-type: none"> The auto calibration values do not match the cylinder gas concentrations. The calibration cylinder is out of gas or is outdated. The calibration cylinder is not connected to the appropriate gas inlet fitting. The GX-3R (Pro) is not correctly inserted in the instrument cradle. 	<ol style="list-style-type: none"> Confirm that the auto calibration values match the concentrations listed on the gas cylinder. Verify that the calibration cylinder contains an adequate supply of fresh test sample. Verify that the calibration cylinder is connected to the appropriate gas inlet fitting. Check to make sure the GX-3R (Pro) is correctly inserted in the instrument cradle. Check all calibration tubing for leaks or for any bad connections. If the fail condition continues, replace the failed sensor(s) in the GX-3R (Pro). If the difficulties continue, contact RKI Instruments, Inc. for further instruction.
Cannot Initiate Bump Test or Calibration of a GX-3R	<ul style="list-style-type: none"> Yellow lever is in the “down” position. 	<ol style="list-style-type: none"> Remove the GX-3R, move the yellow lever into the “up” position, and reinstall the GX-3R.
No IR connection between GX-3R (Pro) and SDM-3R	<ul style="list-style-type: none"> SDM-3R is not turned on. The GX-3R (Pro) is not correctly inserted into the instrument cradle. The IR window is dirty. 	<ol style="list-style-type: none"> Turn on the SDM-3R. If it does not turn on, check that the AC adapter is plugged into an AC socket and to the jack on the left side of the SDM-3R. Check to make sure the GX-3R (Pro) is inserted properly. Clean the IR window on the SDM-3R and GX-3R (Pro). If the difficulties continue, contact RKI Instruments, Inc. for further instruction.

Symptoms	Probable Causes	Recommended Action
Control buttons not functioning correctly for standalone operation	<ul style="list-style-type: none"> The SDM-3R is connected to a computer and the PC Program is running. 	<ol style="list-style-type: none"> 1. Disconnect the USB cable from the back of the SDM-3R if it is connected. See the SDM-3R PC Controlled Configuration Operator's Manual for instructions to use the SDM-3R in PC Controlled configuration.
The Li-ion battery pack in the GX-3R (Pro) is not charging	<ul style="list-style-type: none"> The GX-3R (Pro) has an alkaline battery pack installed. The Li-ion battery pack is faulty. The GX-3R (Pro) is not correctly inserted in the instrument cradle. The charger is malfunctioning. 	<ol style="list-style-type: none"> 1. Check to make sure your GX-3R (Pro) doesn't have an alkaline battery pack installed. 2. Replace the Li-ion battery pack and attempt to charge it. 3. Be sure that the GX-3R (Pro) is fully inserted in the instrument cradle. 4. If the difficulties continue, contact RKI Instruments, Inc. for further instruction.

Charging a GX-3R (Pro)

The SDM-3R can be used to charge the rechargeable Li-ion battery pack in a GX-3R (Pro) equipped with one. To maximize the GX-3R (Pro)'s run time and the battery life, make sure the battery pack's charge is as low as possible before recharging it.

1. If desired, perform a bump test, calibration, or alarm check on a GX-3R (Pro) as described in "Bump Testing" on page 56, "Calibration" on page 60, or "Alarm Check" on page 63.
2. Turn off the GX-3R (Pro) by pressing EDIT ENTER and POWER. If no buttons are pressed for the time period defined in **Auto Power Off** in the PC Program's SDM Window, the docking station will automatically turn off the GX-3R (Pro) and begin the charge cycle.
3. Before the GX-3R (Pro) is turned off, the CHARGE LED will be blinking green. Once the GX-3R (Pro) is turned off, the CHARGE LED will blink orange if the GX-3R (Pro) needs to be charged. The CHARGE LED will be solid green if the GX-3R (Pro) is already fully charged.

NOTE: The SDM-3R does not start charging the batteries until the GX-3R (Pro) is off.

4. If the battery pack is drained enough for the docking station to charge it, the CHARGE LED will continue to blink orange while charging is taking place. The SDM-3R will take approximately 3 hours to charge a fully discharged GX-3R (Pro).

If you are attempting to charge an alkaline battery pack, or if the Li-ion pack is already fully charged, the CHARGE LED will be solid green and no charging will occur.

If the charging process encounters a fail condition, the CHARGE LED will turn steadily red. A fail condition could indicate that there is something wrong with the Li-ion battery pack, or that there is something wrong with the charger.

5. When the charge is complete, the CHARGE LED will turn solid green.

Batteries Too Drained for Standalone Operation

If the batteries in the GX-3R (Pro) do not have enough power to keep the GX-3R (Pro) on during operations with the SDM-3R, the GX-3R (Pro) will turn off.

- Alkaline battery pack: The GX-3R (Pro) LCD indicates **REPLACE BATT**. You must change the batteries before you can use the GX-3R (Pro) with the SDM-3R.

- Li-ion battery pack: The GX-3R (Pro) goes into a 5 minute charge cycle and the LCD indicates **CHARGING**. Once the 5 minute charge cycle has ended, the GX-3R (Pro) will automatically turn back on and connect to the SDM-3R.

Chapter 8: Importing and Viewing Data

Overview

This chapter describes how to import data collected in Standalone Mode into the PC Program. Importing can be done by saving the data to a USB drive or by utilizing the building's LAN network. Data importing is done through the Logs Window which is accessed by clicking the **Logs** button. The two control buttons associated with importing data are **USB Import** and **Net Import**.

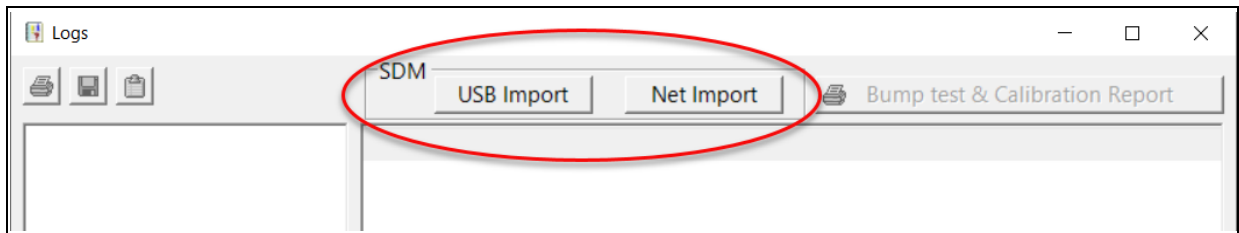

Figure 35: Import Buttons in Logs Window

Importing from a USB Drive

- 1 . Remove the USB drive from the SDM-3R.
- 2 . Insert the USB drive into USB slot on your computer.
- 3 . Click **Start** on the Windows Icon Tray, then select **Programs/SDM-3R**. You may also double click the shortcut created on your desktop. The PC Program is launched and the main program window appears.

NOTE: If you are starting the software for the first time, a message window appears informing you that a database has been created. If this occurs, click **OK**.

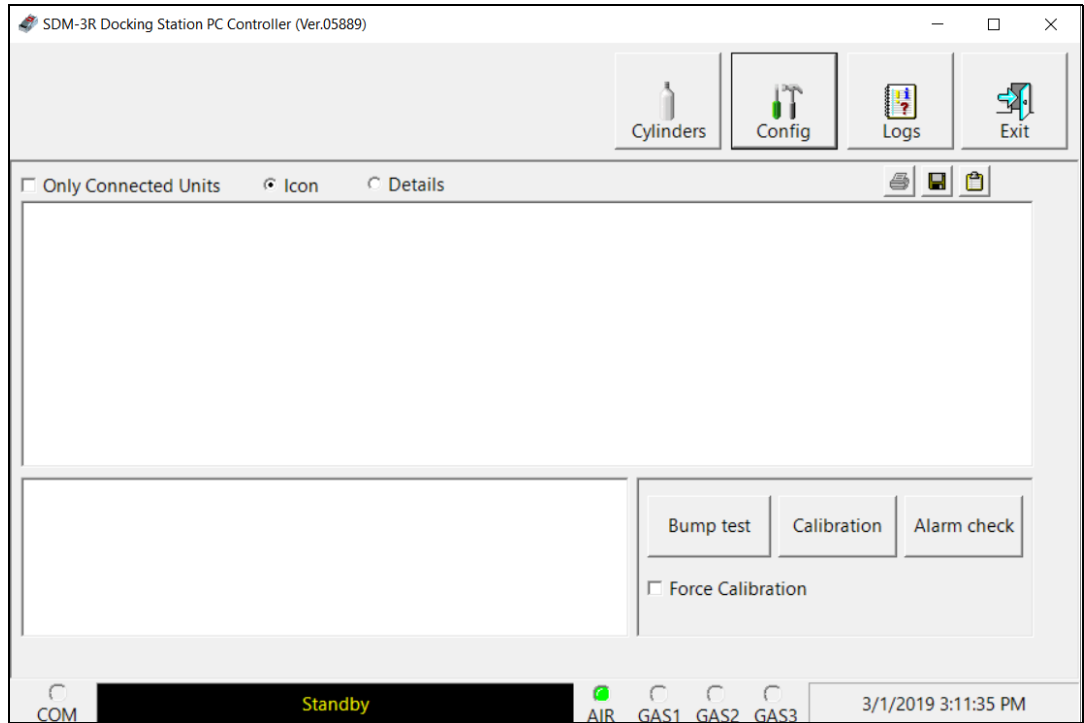

Figure 36: Main Program Window

4 . Click the **Logs** button to display the Logs Window.

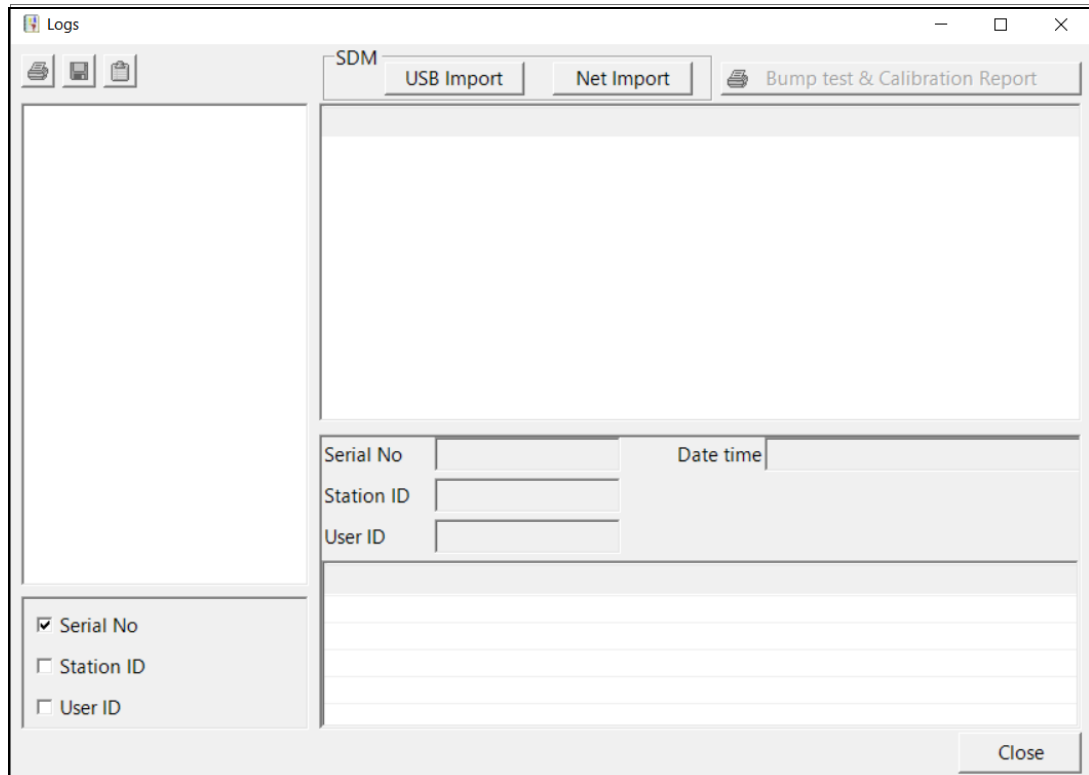

Figure 37: Logs Window

- 5 . Click the **USB Import** button.
- 6 . Navigate to the USB location on your computer.

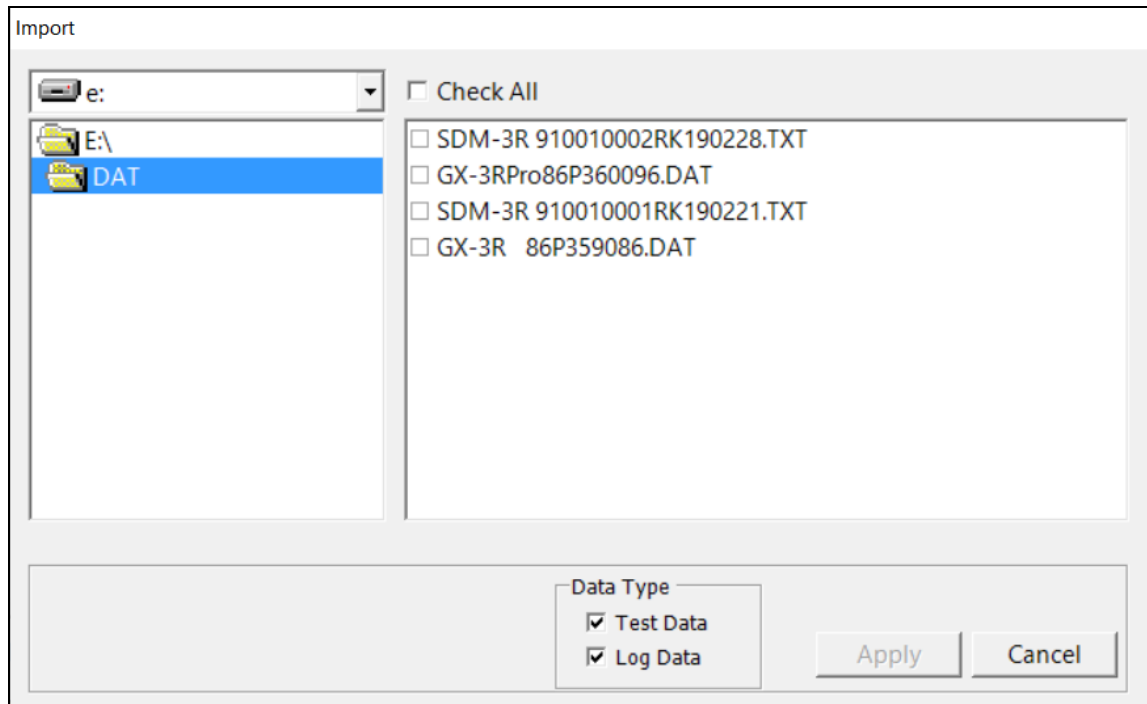

Figure 38: USB Import Window

- 7 . Select the types of data you want to import.
Test Data is data from bump tests, calibrations, and alarm checks done with the SDM-3R (in either Standalone or PC Controlled Mode) and is saved as a .txt file. It will not include data from tests done away from the SDM-3R.
Logs Data is saved instrument data that was downloaded to the USB drive during a data download (in Standalone Mode only) and is saved as a .dat file. It will include Interval Trend data, Alarm Trend data, etc.
- 8 . Select the files that you want to import or use the Check All box to select all of the files.
- 9 . Click **Apply**. A window will appear for a few seconds indicating that the file or files are being imported.
- 10 .The files are now added to the database.

Importing Using the LAN Network

Importing data using the LAN network allows you to import test data (.txt files) from the SDM-3R(s) on the network. You cannot import downloaded logger data using the LAN network.

Before you try to import data using the LAN network, be sure that the LAN connectivity for the SDM-3R(s) was set up as described in “Chapter 5: Detailed Parameter and LAN Setup in PC Program” on page 42.

NOTE: For users with a DHCP network, if the SDM-3R lost power or the network went down after you set up the LAN connectivity, you may need to set up the LAN connectivity again. A new IP address may have been assigned to the SDM-3R when power was restored or when the network came back up.

- 1 . Click **Start** on the Windows Icon Tray, then select **Programs/SDM-3R**. You may also double click the shortcut created on your desktop. The PC Program is launched and the main program window appears.

NOTE: If you are starting the software for the first time, a message window appears informing you that a database has been created. If this occurs, click **OK**.

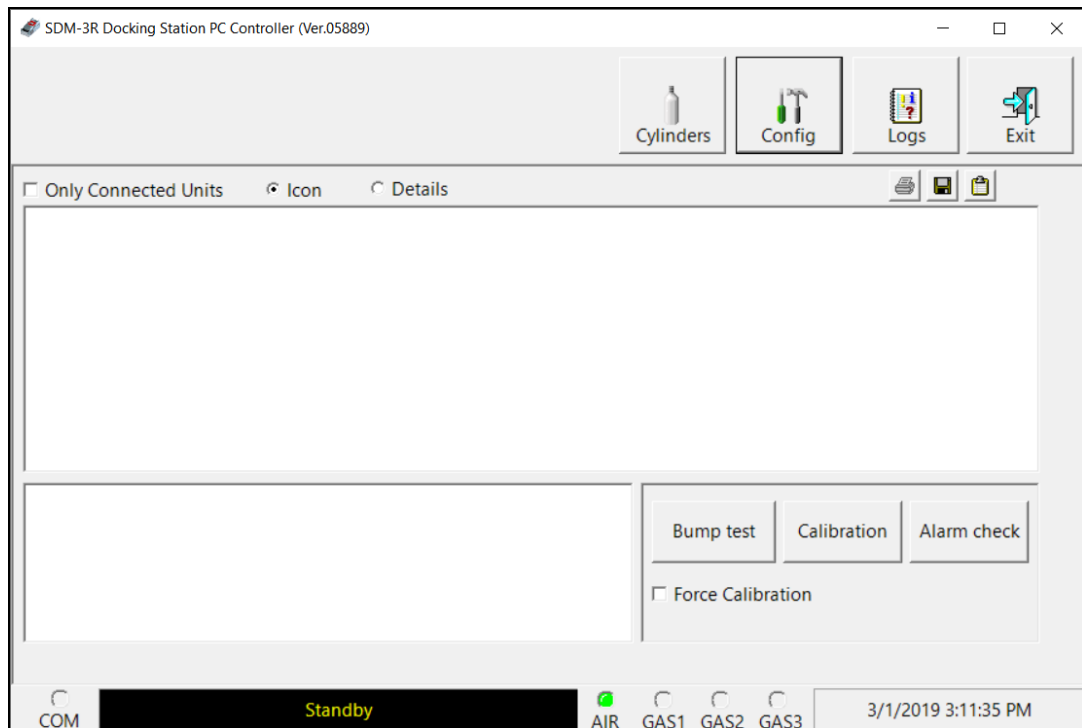

Figure 39: Main Program Window

2 . Click the **Logs** button to display the Logs Window.

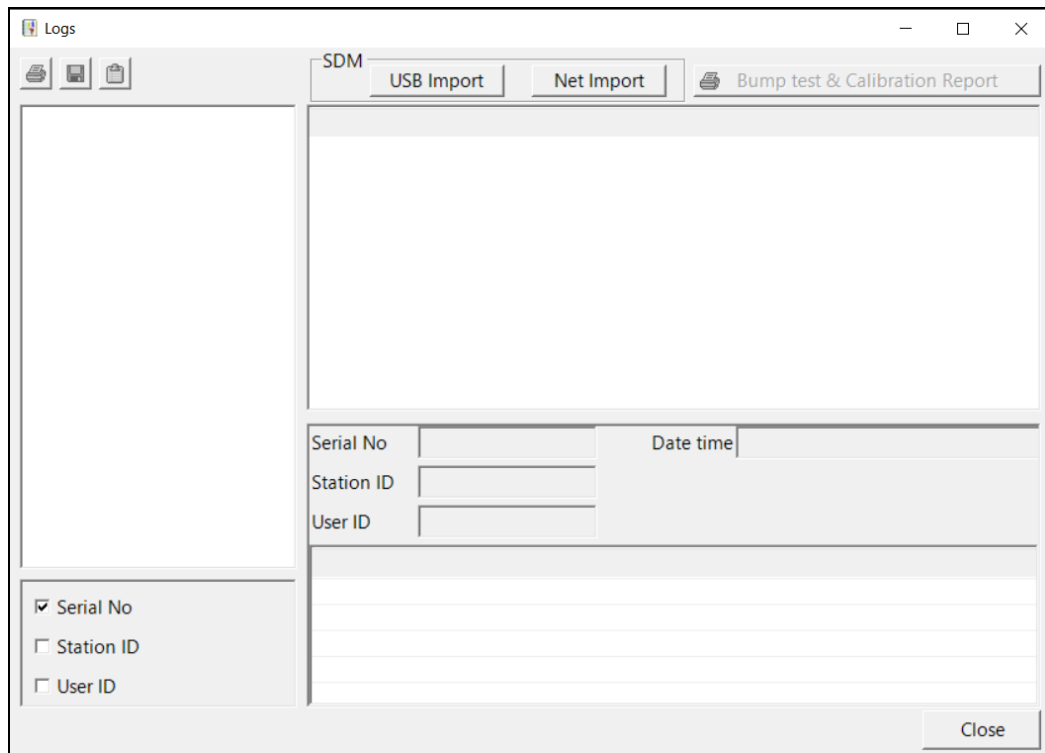

Figure 40: Logs Window

3 . Click the **Net Import** button. The SDM-3Rs that you set up in “Chapter 5: Detailed Parameter and LAN Setup in PC Program” on page 42 will appear.

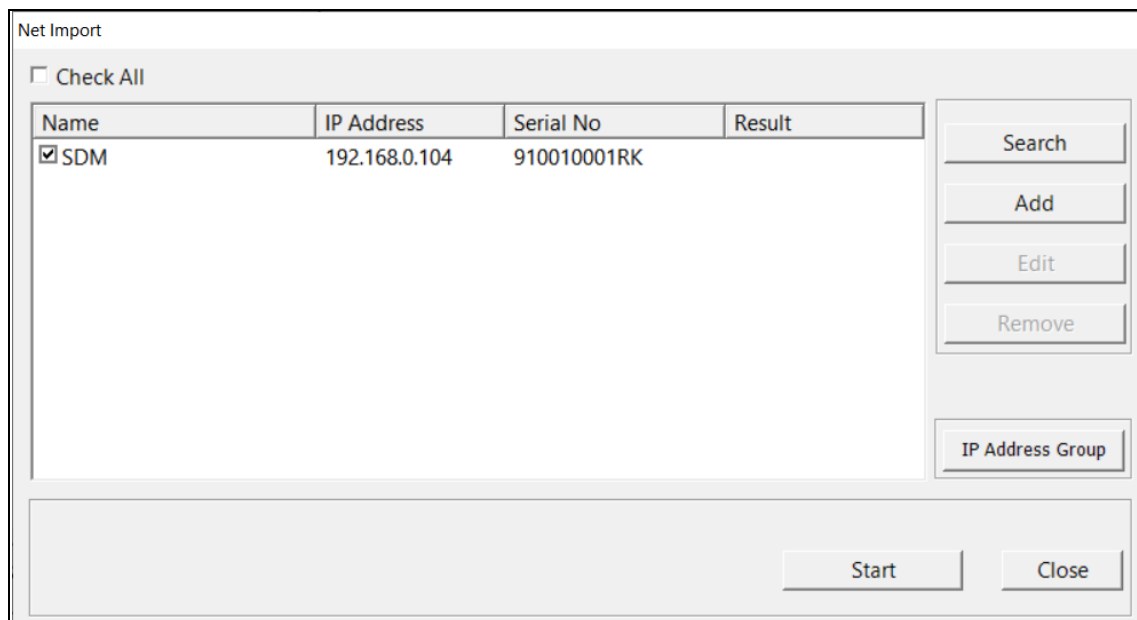

Figure 41: Net Import Window

4 . Select the SDM-3R(s) whose files you want to import or use the Check All box to select all of the SDM-3R(s).

- 5 . Click **Start**. The **Result** area for each SDM-3R will indicate that the program is communicating with the docking station and will indicate how many files were imported once the import is complete.

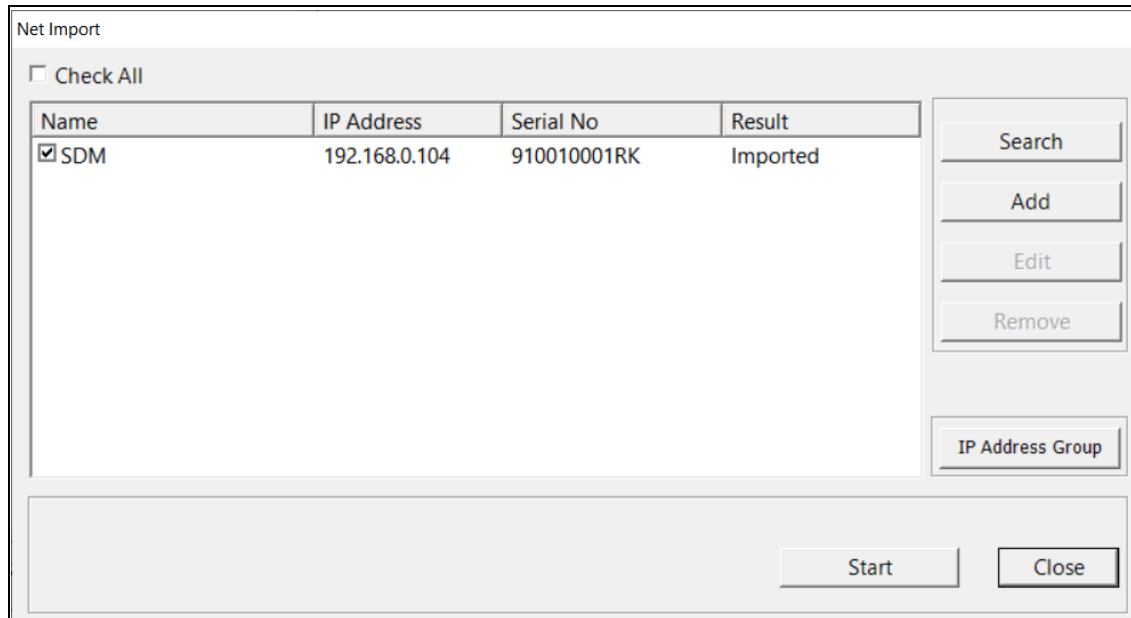

Figure 42: Net Import Successful

NOTE: If the data import is not successful, you may need to set up the LAN connectivity again. For users with a DHCP network, if the SDM-3R lost power or the network went down for a period of time, a new IP address may have been assigned to the SDM-3R when power was restored or when the network came back up.

- 6 . Click **Close**.
- 7 . The files are now added to the database.

Viewing Imported Data

See Chapter 9 in the SDM-3R PC Controlled Configuration manual for instructions to organize, view, print, and delete imported data.

Exiting the PC Program

To exit the PC Program, do the following:

- 1 . Click the **Exit** button in the upper right corner of the data view window. A confirmation window will appear.
- 2 . Click the **OK** button to exit the program or the **Cancel** button to return to the program.

Chapter 9: Spare Parts List

Table 10: Spare Parts List

Part Number	Description
06-1248RK	Polyurethane tubing, 5/16-inch OD x 3/16-inch ID, for connecting to inlet fittings
06-1248RK-03	3 foot length of 5/16-inch OD x 3/16-inch ID, for connecting calibration cylinder to inlet fittings
06-1254RK	Polyurethane tubing, 7/16-inch OD x 5/16-inch ID, for exhaust tube, 15 feet maximum
06-1254RK-10	10 foot length of 7/16-inch OD x 5/16-inch ID, for exhaust tube
10-1119	Screw, M3 x 12 mm, for securing charging jack to the SDM-3R
10-1233-06	Screw, M4 x 8 mm, for connection brackets, wall mounting brackets, and/or panel on right side of SDM-3R
14-0401	Wall mounting brackets, set of 3, with screws
14-0401-02	Wall mounting brackets, set of 2, with screws
14-0402	Connection brackets, set of 2, with screws, for connecting SDM-3Rs together
17-4710	Sample fitting plugs
21-1959	Panel cover for right side of SDM-3R
33-0167RK	Particle air filter replacement, CF-8369
33-6015RK	CO ₂ scrubber, for zeroing CO ₂ sensor
47-5073RK	USB cable, Type A to Type B, for connecting to a computer
47-5088	Ethernet cable, black, 5 ft.
49-0133	Single-station AC adapter
71-0487	Operator's Manual, SDM-3R Docking Station Standalone Configuration (this document)
71-0488	Operator's Manual, SDM-3R Docking Station PC Controlled Configuration
81-0000RK-51	Calibration cylinder, 200 ppm H ₂ in air, 34 liter steel
81-0012RK-01	Calibration cylinder, 50% LEL CH ₄ in air, 34 liter steel
81-0012RK-03	Calibration cylinder, 50% LEL CH ₄ in air, 103 liter
81-0018RK-01	Calibration cylinder, 50% LEL isobutane in air, 34 liter steel
81-0018RK-03	Calibration cylinder, 50% LEL isobutane in air, 103 liter
81-0071RK-01	Calibration cylinder, 5,000 ppm CO ₂ in nitrogen, 34 liter steel
81-0071RK-03	Calibration cylinder, 5,000 ppm CO ₂ in nitrogen, 103 liter
81-0072RK-01	Calibration cylinder, 2.5 %vol CO ₂ in nitrogen, 34 liter steel

Table 10: Spare Parts List

Part Number	Description
81-0072RK-03	Calibration cylinder, 2.5 %vol CO ₂ in nitrogen, 103 liter
81-0076RK	Calibration cylinder, 17 liter
81-0076RK-01	Calibration cylinder, zero air, 34 liter steel
81-0076RK-03	Calibration cylinder, zero air, 103 liter
81-0078RK-01	Calibration cylinder, 100% N ₂ , 34 liter steel
81-0078RK-03	Calibration cylinder, 100% N ₂ , 103 liter
81-0090RK-01	Calibration cylinder, 3-gas (50% LEL CH ₄ /12% O ₂ /50 ppm CO), 34 liter steel
81-0090RK-03	Calibration cylinder, 3-gas (50% LEL CH ₄ /12% O ₂ /50 ppm CO), 103 liter
81-0142RK-02	Calibration cylinder, 5-gas (CH ₄ /O ₂ /H ₂ S/CO/SO ₂), 58 liter
81-0142RK-04	Calibration cylinder, 5-gas (CH ₄ /O ₂ /H ₂ S/CO/SO ₂), 34 liter aluminum
81-0154RK-02	Calibration cylinder, 4-gas (50% LEL CH ₄ /12% O ₂ /50 ppm CO/25 ppm H ₂ S), 58 liter
81-0154RK-04	Calibration cylinder, 4-gas (50% LEL CH ₄ /12% O ₂ /50 ppm CO/25 ppm H ₂ S), 34 liter aluminum
81-0158RK-02	Calibration cylinder, 4-gas (50% LEL Isobutane/12% O ₂ /50 ppm CO/25 ppm H ₂ S), 58 liter
81-0158RK-04	Calibration cylinder, 4-gas (50% LEL Isobutane/12% O ₂ /50 ppm CO/25 ppm H ₂ S), 34 liter aluminum
81-0170RK-02	Calibration cylinder, 5 ppm SO ₂ in nitrogen, 58 liter
81-0170RK-04	Calibration cylinder, 5 ppm SO ₂ in nitrogen, 34 liter
81-1054-01	Demand flow regulator with 3 feet of calibration tubing, for 34 liter aluminum, 58 liter, and 103 liter cylinders (cylinders with internal threads)
81-1055RK	Demand flow regulator, for 17 liter and 34 liter steel cylinders (cylinders with external threads)
81-1500RK	Cylinder holder for 58 liter calibration cylinder
81-1501RK	Cylinder holder for 103 liter calibration cylinder
81-1502RK	Cylinder holder for 34 liter calibration cylinder
81-9043RK-01	Calibration cylinder, 4-gas (50% LEL CH ₄ /12% O ₂ /50 ppm CO/5000 ppm CO ₂), 34 liter steel
81-9043RK-03	Calibration cylinder, 4-gas (50% LEL CH ₄ /12% O ₂ /50 ppm CO/5000 ppm CO ₂), 103 liter

Table 10: Spare Parts List

Part Number	Description
81-9044RK-02	Calibration cylinder, 4-gas (50% LEL CH ₄ /12% O ₂ /50 ppm CO/25 ppm H ₂ S/5000 ppm CO ₂), 58 liter
81-9044RK-04	Calibration cylinder, 4-gas (50% LEL CH ₄ /12% O ₂ /50 ppm CO/25 ppm H ₂ S/5000 ppm CO ₂), 34 liter aluminum
81-9045RK-02	Calibration cylinder, 4-gas (50% LEL CH ₄ /12% O ₂ /50 ppm CO/25 ppm H ₂ S/2.5% CO ₂), 58 liter
81-9045RK-04	Calibration cylinder, 4-gas (50% LEL CH ₄ /12% O ₂ /50 ppm CO/25 ppm H ₂ S/2.5% CO ₂), 34 liter aluminum
81-SDM3R100	Docking station for GX-3R (Pro), 1 solenoid, includes docking station, single-station AC adapter, air filter, exhaust tube
81-SDM3R101	Docking station for GX-3R (Pro), 1 solenoid, includes docking station, single-station AC adapter, air filter, exhaust tubing, USB cable, Ethernet cable, and USB drive
81-SDM3R201	Docking station for GX-3R (Pro), 2 solenoids, includes docking station, single-station AC adapter, air filter, exhaust tubing, USB cable, Ethernet cable, and USB drive
81-SDM3R301	Docking station for GX-3R (Pro), 3 solenoids, includes docking station, single-station AC adapter, air filter, exhaust tubing, USB cable, Ethernet cable, and USB drive
82-6105RK	USB drive