



CATALOG NO. 100

Severance®

CUTTING TOOLS

Precision Finishing

Chatterless Design









Graphic Index	2
Chatterless Countersinks	49
Tube Deburring & Finishing	31
Specials	91
Carbide Flat Files	72
Midget Mills®	7
Sets	81
Regrind Services	89
Numerical (EDP) Index	98

Severance® Tool Industries Inc. Saginaw, Michigan 989-777-5500

© 2008 Severance Tool Industries, Inc.

GRAPHIC LIST OF *Severance*[®] POPULAR PRODUCTS

<p>Chatterless-Countersinks™ 1/8" Thru 3" Diameter HSS & Carbide</p>  <p>Page 50-52</p>	<p>3N1® Drill Point Countersink</p>  <p>Page 57-58</p>	<p>4 Flute Chatter-Free™ Econo-Sinks® Countersink 1/8" Thru 3" Diameter HSS & Carbide</p>  <p>Page 60-61</p>	<p>Single Flute Countersinks 1/8" Thru 3" Diameter HSS & Carbide</p>  <p>Page 61-62</p>
<p>CNC-K™ Precision Chatterless-Countersinks™</p>  <p>Page 53-54</p>	<p>Multi Flute Countersinks 30° & 45° C/L Angles HSS & Carbide</p>  <p>Page 55-57</p>	<p>Quick Change Countersinks 3N1-QC™ Heads & Shanks</p>  <p>Page 59</p>	<p>Adjustable Drill Countersinks</p>  <p>Page 63</p>
<p>Stop-Countersink Cutters HSS & Carbide</p>  <p>Page 65-67</p>	<p>Micrometer Stop Countersink Units</p>  <p>Page 64</p>	<p>Whirly-Gig® Handle 1/4"-28 threaded handle</p>  <p>Page 41 & 80</p>	<p>Hole Radius Cutter Hand Deburring Cutters With Comfy Grip Handles</p>  <p>Page 43</p>
<p>Tube End Chamfering Mills HSS & Carbide</p>  <p>Page 34</p>	<p>Tube End Chamfering Mills HSS & Carbide</p>  <p>Page 37</p>	<p>Tube End Forming Cutters HSS & Carbide</p>  <p>Page 38-40</p>	<p>Rod-End Forming Cutters Production Finishing of Rod Ends</p>  <p>Page 44</p>
<p>Inside Deburring Cutters 30° & 45° C/L Angles HSS & Carbide</p>  <p>Page 32-33</p>	<p>Outside Deburring Cutters 30° & 45° C/L Angles HSS & Carbide</p>  <p>Page 33</p>	<p>Inside Chamfering Mills 30° & 45° C/L Angles HSS</p>  <p>Page 35</p>	<p>Outside Chamfering Mills 30° & 45° C/L Angles HSS</p>  <p>Page 36</p>
<p>Midget Mills® HSS & Carbide Rotary Files and Burs</p>  <p>Page 4-21</p>	<p>Carbo-Mills™ Carbide Double Cut Rotary Files and Burs</p>  <p>Page 4-24</p>	<p>d-burrs™ Plastic Deburring Tools</p>  <p>Page 28</p>	<p>Tube Hole Deburring Tools HSS & Carbide</p>  <p>Page 16 & 40</p>
<p>Junior Mills® & Lab Mills™ Miniature Deburring Tools</p>  <p>Page 25-27</p>	<p>Micro-Mills™ & Bore-Mills™ Precision Hole Finishing</p>  <p>Page 29</p>	<p>Edge Deburring Cutters</p>  <p>Page 45</p>	<p>Carbide Hand Files also CBN, Diamond, H.S.S.</p>  <p>Page 71-77</p>
<p>Electro Dressers Standard & Special HSS & Carbide</p>  <p>Page 46-48</p>	<p>Disc Cutters HSS & Carbide</p>  <p>Page 45</p>	<p>Resharpener Service Carbide & HSS</p>  <p>Page 89-90</p>	<p>Special Tools CAD Designed and Engineered to Solve Your Cutting and Deburring Problems</p>  <p>Page 91-97</p>

For Numerical Index See Page 98

Severance TOOL INDUSTRIES, INC.
3790 Orange St. • P.O. Box 1866
Saginaw, MI 48605
989-777-5500 • FAX 989-777-0602
Website: www.severancetool.com
E-Mail: severancetool@sbglobal.net

The information shown in this publication is effective as of September, 2011, superseding and canceling all previous technical information published by Severance Tool Industries, Inc. All tools, specifications, and technical information contained herein is subject to change, correction, or cancellation without notice. No performance standards are expressed or implied since service conditions are controlled by the user.
Copyright © 2011, Severance Tool Industries, Inc.



Phone: 989-777-5500 Fax: 989-777-0602

E-Mail: severancetool@sbcglobal.net

Severance Tool Industries Inc. • POB 1866 • Saginaw, MI 48605

Table of Contents

Graphic List of Popular Tools	1	Specialty Tools con't	
Table of Contents	2	Disc Cutters.....	45
Company History	3	Electrode Dressers.....	46
Rotary Deburring Tools		Rod End Forming Cutters.....	44
Midget Mills®.....	4-21	Aircraft Style Rivet Shavers.....	67
Carbo-Mills™.....	4-24	End Mills.....	68
Ecarbo-Mills™.....	22-24	Carbo-Routs™.....	68
Sever-Cuts™.....	4-18	Drill-Reamers.....	69
8" Long Shank Midget Mills®.....	21	Ball Seat Reamers.....	69
Di-Car Mills™.....	30	Micro Reamers.....	70
Die Mills.....	30	Micro-Center Reamers™.....	70
Junior Mills®.....	25	Files	
Lab Mills™.....	26	Carbide Hand Files.....	71-76
Extra Length Lab Mills™-Surgical Mills.....	27	Diamond Hand Files.....	71-76
Ball Nose Deburring Cutters.....	27	CBN (Cubic Boron Nitride) Hand Files.....	71-76
Micro-Mills™.....	29	High Speed Steel Hand Files.....	71-76
Bore Mills.....	29	Carbide Machine Files.....	77
d-burrs™.....	28	Carbide Die Files.....	77
Junior d-burrs™.....	28	Mini-Scraper™.....	42
Tube Tools		Shanks & Miscellaneous	
Inside Deburring Cutters.....	32-33	Disc Cutter Arbors.....	79
Outside Deburring Cutters.....	33	Glenzer Sleeves.....	52,78
Tube End Deburring Cutters.....	34	Straight.....	78
Inside Chamfering Mills.....	35	Tapered.....	79
Outside Chamfering Mills.....	36	Straight Internal Threads.....	80
Tube End Chamfering Mills.....	37	Threaded Handles.....	80
Tube End Forming Cutters.....	38-40	Sets & Kits	
Tube Hole Deburring Tools.....	40	Midget Mills®.....	81
Countersinks		Carbo-Mills™.....	81
6-Flute H.S.S./Carbide Chatterless-Countersinks™.....	50-51	Sever-Cuts™.....	82
6-Flute Threaded H.S.S. Chatterless-Countersinks™.....	51	Di-Car Mills™.....	82
6-Flute Heavy Duty H.S.S. Chatterless-Countersinks™.....	52	Junior Mills®.....	82-83
6-Flute Chatterless-Countersinks™ for Wheels.....	52	Lab Mills™.....	83
CNC-K™ Precision Chatterless-Countersinks™.....	53-54	Extra Length Lab Mills™.....	83
Multi-Flute Countersinks.....	55-57	Single Flute Countersinks.....	83-84
3N1® Drill Point Countersink.....	57-58	4-Flute Chatter-Free™ Econo-Sinks® Countersinks.....	84
3N1-QC™ Quick Change Drill Point.....	59	3N1® Drill Point Countersinks.....	84-85
4-Flute Chatter-Free™ Econo-Sinks®.....	60-61	6-Flute Chatterless-Countersinks™.....	85-86
Single Flute.....	61-62	Whirly-Gig® Handle.....	42, 86
Adjustable Drill Countersinks.....	63	Speedy Handle™.....	41, 86
Micrometer Stop-Countersink Units.....	64	Tool Master Set #811.....	86
Stop-Countersink Cutters.....	65-67	Services	
Specialty Tools		Grayhone™.....	4
Surgical Mills.....	27	Contract Services.....	88
Whirly-Gig® Handle.....	41,80	Regrinding.....	89-90
Speedy Handle™.....	42,80	Special Order.....	91-97
Hole Radius Deburring Cutters.....	43	Programing Information/Countersinks	88
Edge Deburring Cutters.....	45	Numerical Index	98

The information shown in this publication is effective as of September, 2011, superseding and canceling all previous technical information published by Severance Tool Industries, Inc. All tools, specifications, and technical information contained herein is subject to change, correction, or cancellation without notice. No performance standards are expressed or implied since service conditions are controlled by the user. **Copyright © 2011, Severance Tool Industries, Inc.**



Phone: 989-777-5500 Fax: 989-777-0602

E-Mail: severancetool@sbcglobal.net

Severance Tool Industries Inc. • POB 1866 • Saginaw, MI 48605

Severance® Tool Industries, Inc. - A History of Innovation



Rollin M. Severance
Founder

Rollin M. Severance developed the first ground rotary files and went on to invent the ground-from-solid, after hardening tools he called them Midget Mills®, which has precision ground tooth structures and accuracy. While it looks like a rotary file, it cuts with all the sharpness and sureness of milling cutters used on large machine tools. Where early rotary files merely rubbed the metal away, Midget Mills® cut tiny chips and they found use in many manufacturing applications.

His deep seated belief that full utilization of Man's personal gifts is a part of God's purpose, led him to build a business on honesty, integrity, quality, and service.

As the use of his new tools increased, he added more styles and shapes that previously were not able to be made. He next developed and patented the Combination Inside and Outside Tube Deburring Cutters, followed by the Six Flute Chatterless-Countersink™, Chatterless Ball Seat Reamers™, and the Four Flute Chatter-Free™ Countersink. The success of chatterless facing and bottoming tools brought numerous applications of these cutters. Diesel and Automotive Engineering began selecting Severance Cutters for many jobs being run in their plants.

In 1934 Severance Cutters found their way into Aeronautical Plants, and in the same year Severance cutters were presented at a conference of Body Engineers and they were rapidly adopted into the leading Body plants.

For improvement in the manufacturing of his new tools, Mr. Severance developed and patented a new Precision Spindle for grinding wheels, an improved grinding wheel mounting system and a bearing pre-load and adjustment system for spindles.



Robert H. Severance
President 1985-2001



Charles Severance
Vice President



Ralph Severance
Director

For the expanding Aircraft Industry, Severance Tool developed Chatter-Free™ Aircraft Stop-Countersinks, developed and patented a Micrometer style setting Stop Countersink holder offering precision depth control, Multi Flute Rivet Shavers, and developed and patented Carbide Hand Files (an improved version of the flat file) and Tube End Forming Cutters.

Severance Tool continued to develop innovation and time saving "Tools for Industry" and introduced many firsts including Chatterless-Countersinks™, Electrode Dressing Cutters, Hole Radius Cutters, Rod End Forming Cutters, Lab Mills™, Edging Mills, Sever-Cut™ Mills for aluminum, Bore Mills®, Micro-Center® Reamers, AC Adjustable Countersinks, Micro-Mills™, and Die Mills.

In 1939 Severance Tool moved to their present facility in Saginaw, Michigan and all new tool production was consolidated into this plant. During this time Severance Tool started a sister company of regrind centers located close to the major aircraft manufacturing that resharpened Severance Tools. In later years as transportation improved, these Resharpening centers were closed, and all operations moved back to our Saginaw, Michigan expanded plant and headquarters. Severance Tool has continued to develop tools to improve part finishing, reduce chatter, and improve production of ship building, weapon production, transportation, medical, appliance, airframe, and more.



Old factory Photo

Severance Tool continues to develop unique tools to solve customer problems and improve production and part finishing. Some of our recent tools are the 3N1™ Drill Point Countersink, CNC-K™ Precision Six Flute Chatterless-Countersinks™, 3N1-QC™ quick change countersink system, d-Burrs™ for plastic part deburring, Grayhorne® process for tools, and an improved Mini-Scraper™, Severance Tool also introduced individual packaging of our tools simplifying use in Tool Cribs and Vending Machines, along with extensive bar-coding.

Severance Tool does a wide variety of altered standards and made to print special cutters. Our Engineering staff will assist you with your cutting tool or part finishing problem. See many examples throughout this new catalog. We also have a staff of specialists on hand for the many types of regrinding operations of our tools. Contact us regarding the savings of having tools reground.

The sons of Rollin Severance and our employees continue the tradition of innovation, quality, and service. We thank you for your business. We are the originators, we have been copied but not surpassed.



Our Modern Facility

Phone: 989-777-5500 Fax: 989-777-0602
E-Mail: severancetool@sbcglobal.net

Severance®

Severance Tool Industries Inc. • POB 1866 • Saginaw, MI 48605

Midget Mills®

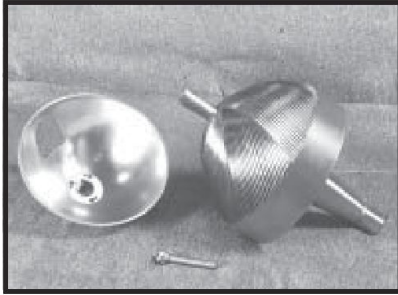

Over the years Severance Tool has become known not only as the originator of the ground flute rotary file, Midget Mill®, and Chatterless-Countersinks™, but also the manufacturer and inventor of the highest quality unique rotary deburring and finishing tools. The many fluting geometries offered in the Severance Catalog are backed by the highest of fluting standards. These standards, quality craftsmen, quality machinery and the highest requirements for materials assure a quality tool that to the trained eye is no less than beautiful. There really is a difference!

High Speed Steel - In general, high speed steel rotary files are better for less rigid, hand operations where some chatter is likely. High speed steel Midget Mills® also come with a standard chip breaker, holding a good finish while improving the cut due to producing smaller chips. Severance high speed steel cutting tools are manufactured with quality M2 steel with a Rockwell of 63-65. Hard cutting edges are backed up by a tough, fatigue-resistant body to give excellent performance under the most demanding service conditions.



Carbide - Carbide rotary files are for operations in rigid environments where chatter is minimized and tool control is high. Severance uses special grades of carbide, which are formulated by custom suppliers and sintered at the Severance plant. The carbide is a special blend of Tungsten and Cobalt with a Rockwell A scale hardness of 91.7 to 92.2 which is comparatively harder and tougher for a longer tool life. These custom grades have been selected because they hold a fine cutting edge, which can be reground many times before the tool is used up. Carbide may be operated at many times the speed of steel tools and generally yields as much as five to ten times the service life.



Tool Coatings - Many high speed steel tools can be used where carbide might be easily chipped. Gold TiN-coated tools feature the same tough HSS bodies as the high speed steel line, but have a layer of super-hard titanium nitride deposited on their surfaces. These tools, available on special order, will out last regular high speed steel cutters, under most conditions, by a factor of about 3 to 1. Some of the other coatings available on our Carbide and H.S.S. tools include TiCN (titanium carbon nitride) and TiAlN (titanium aluminum nitride). Consult our engineering staff with your requirements and about other coatings.



Grayhone™ - A process developed by Severance Tool which eliminates the need for a break-in period on tools. Grayhoned tools are ready to operate at full production speeds right out of the package. This saves time and money in a full range of production operations. Severance utilizes an additional proprietary process in the production of Grayhone™ tools. After the tools are sharpened with a grinding wheel, they are also honed before shipment to users. The Grayhone™ process also imparts a distinctive appearance to the tools that provides an added benefit. The dull gray color offers a built-in wear indicator that helps quality control efforts. When the cutting edges start to look shiny, it means that they are becoming dull, and the tools need replacement or resharpening. An overly dull tool causes bad part finishes, and increases the cost of resharpening.

Severance® Tool Industries, Inc.
Manufactures Code 662018
Website: www.severancetool.com



Phone: 989-777-5500 Fax: 989-777-0602

E-Mail: severancetool@sbcglobal.net

Severance Tool Industries Inc. • POB 1866 • Saginaw, MI 48605

Midget Mill® Classifications

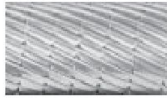

H.S.S. Midget Mills® - Right hand spiral tooth pattern with a **light chipbreaker** originated by Severance Tool. These tools can take more shock than carbide. Mainly used on non-work hardening materials. Materials applications can include M2, M42, cold and hot roll steels, aluminum, cast iron and bronze.

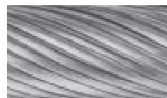

Carbide Midget Mills® - Right hand spiral tooth pattern invented by Rollin Severance, mainly intended for machine applications because of its deep radial flutes. Able to take a substantial amount of material off in an environment where the tool is not allowed to bounce or chatter out of control. Works best with materials applications using carbon steels, cast steels, gray irons, some stainless steel, tungsten, and nickel alloys.

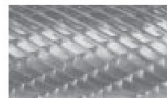

Carbo-Mills™ - Features a **double cut** tooth pattern, first introduced by Severance Tool. Intended for applications where there is substantial stock removal and a rough to medium finish is required. Works best with ferrous, non-work hardening materials. Materials applications can include steels, aluminum, cast iron, and bronze.



Sever-Cuts™ - Developed by Severance Tool, these tools feature a **super coarse** cut designed with very course deep positive flutes with a large flute radius to remove material without loading up. Works best with nonferrous materials including aluminum, copper, bronze, nickel, and magnesium. Can be used with either hand or machine operations.



Tangent Mills™ - Are **left hand spiral**, right hand cutting, and are especially designed to control tool wandering on curved surfaces. Ideal for finishing holes in tubing. Works best with Ferrous, non-work hardening materials. Material applications can include M2, M42, cold & hot rolled steels, aluminum, cast iron, and bronze. See catalog page 16 for example.



d-burrs™ - Feature the **Herringbone™** cut invented by Severance Tool for fine finishing of plastic, aluminum, steel, and similar materials. The Herringbone™ Cut features alternating right hand and left hand flutes to give a fine finish on difficult deburring problems. See page 28 for standard shapes and sizes.

Other tooth patterns available as a special cut upon request. Here are a few other examples.



Rasp or Diamond Cut



Straight Cut



Chatterless Chamfer Cut™



Curve Tooth Cut

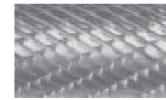

Tuff-Cut

Pitches and their Cut Numbers

The pitches of teeth ground on Severance Midget Mills® are illustrated on page 6, in full scale. The chart at the right relates cut numbers to tool diameters for Fine, Standard, Coarse and Super Coarse pitches. Standard pitch will always be supplied unless otherwise specified. If an unlisted pitch is required, order by cut number.

This cut numbering system applies to Severance Midget Mills®, Junior Mills®, Carbo-Mills™, etc., and to hand files. Sever-Cut™ tools all have "super coarse" teeth.

Dia.	Fine Cut #	Std. Cut #	Coarse Cut #	Super Coarse* (Teeth)	Dia.	Fine Cut #	Std. Cut #	Coarse Cut #	Super Coarse*
3/32"	2	3	5	Per Tool)	9/16"	5	7	9	
1/8"	3	4	5		5/8"	5	7	9	10
3/16"	3	5	6		3/4"	6	8	10	12
1/4"	4	5	7	4	7/8"	6	8	10	
5/16"	4	6	7		1"	6	8	10	16
3/8"	4	6	8	6	1-1/8"	6	9	11	
7/16"	5	6	8		1-1/4"	6	9	11	
1/2"	5	7	9	8	1-1/2"	7	9	12	

*Super Coarse Cuts are recommended for use on aluminum and other nonferrous materials for heavy, fast, stock removal



Phone: 989-777-5500 Fax: 989-777-0602

E-Mail: severancetool@sbcglobal.net

Severance Tool Industries Inc. • POB 1866 • Saginaw, MI 48605

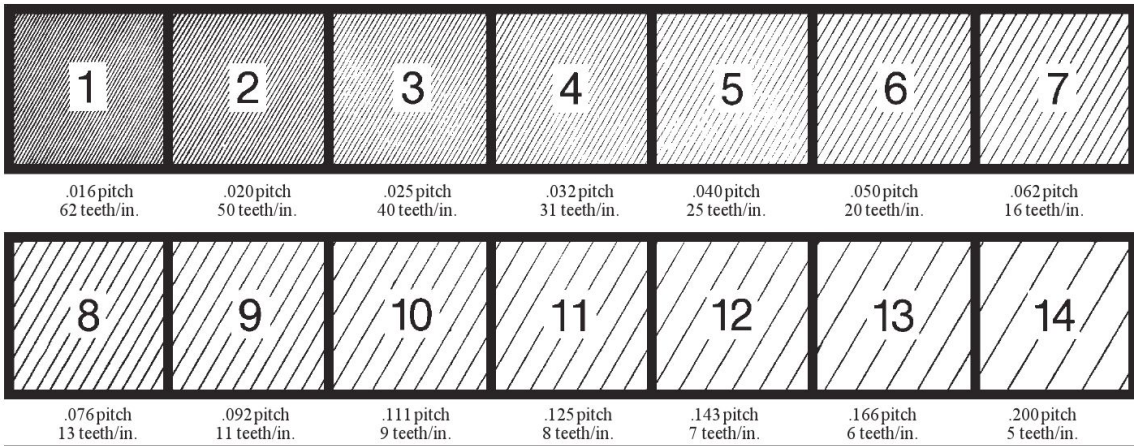

Midget Mills® Identification System

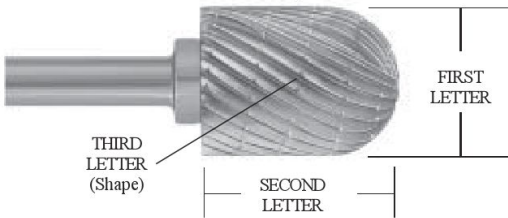

The third letter is the shape of the tool. In some cases, additional descriptive information is also part of the tool number . . . EC for End Cutting, 45 for a 45° angle, etc. All carbide tools carry the suffix, -W.

The First letter designates the largest diameter.
The Second letter designates the length of cutting portion.
The Third letter designates the general shape as illustrated.

A-1/8"	G-1/2"	M-1-1/8"	S-2"	Y-4-1/2"
B-3/16"	H-9/16"	N-1-1/4"	T-2-1/4"	Z-5"
C-1/4"	I-5/8"	O-1-3/8"	U-2-1/2"	
D-5/16"	J-3/4"	P-1-1/2"	V-3"	
E-3/8"	K-7/8"	Q-1-5/8"	W-3-1/2"	
F-7/16"	L-1"	R-1-3/4"	X-4"	

Midget Mills® are identified by a three-letter "tool number." The first and second letters specify cutting diameter and length.

Standard Shape Designations

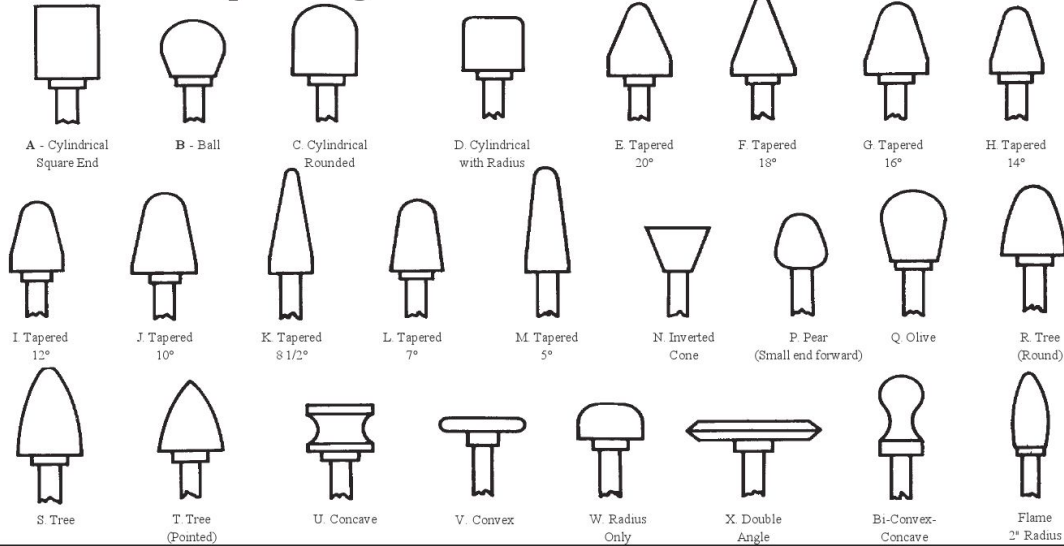

Severance Tool Industries, Inc.
Manufactures Code 662018
Website: www.severancetool.com



Phone: 989-777-5500 Fax: 989-777-0602

E-Mail: severancetool@sbcglobal.net

Severance Tool Industries Inc. • POB 1866 • Saginaw, MI 48605

Shape A Midget Mills®





Our founder, R.M. Severance, originated these tools in 1931. Today, throughout the industry, it is the standard, accepted, rotary cutting, burring and finishing tool. The Midget Mill® is efficient and practical for finishing up molds, smooth welds, clean castings, and smooth plastic edges in job or production operations. HSS Midget Mills® have Chip Breaker tooth patterns.

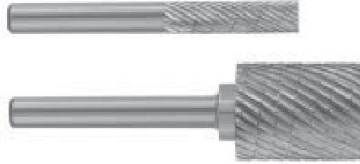

H.S.S. and Carbide Midget Mills®
Come with 1/4" shanks



We're The Originators! We've Been "Copied" But Not Surpassed.

		 H.S.S. Midget-Mill® Single Cut Chip Breakers		 H.S.S. Midget-Mill® Single Cut-EC Chip Breakers		 Carbide Midget-Mill® Single Cut		 Carbide Midget-Mill®-EC Single Cut	
Head Dia.	Flute Length	Midget Mill® Name	EDP Order Number	Midget Mill® Name	EDP Order Number	Midget Mill® Name	EDP Order Number	Midget Mill® End Cut Name	EDP Order Number
1/8"	1/2"	AGA	22930	AGA-EC	22960	AGA-W	23280	AGA-EC-W	23300
1/8"	5/8"	-	-	-	-	AIA-W	23281	AIA-EC-W	23301
1/8"	3/4"	AJA	22931	AJA-EC	22961	-	-	-	-
1/8"	1"	ALA	22932	ALA-EC	22962	-	-	-	-
1/8"	1-1/4"	ANA	22933	ANA-EC	22963	-	-	-	-
1/8"	1-1/2"	APA	22934	APA-EC	22964	-	-	-	-
5/32"	5/8"	-	-	-	-	-	-	-	-
3/16"	1/2"	BGA	22935	BGA-EC	22965	BGA-W	23282	BGA-EC-W	23302
3/16"	5/8"	-	-	-	-	BIA-W	23283	BIA-EC-W	23303
3/16"	3/4"	BJA	22936	BJA-EC	22966	-	-	-	-
3/16"	1"	BLA	22937	BLA-EC	22967	-	-	-	-
1/4"	1/2"	CGA	22938	CGA-EC	22968	CGA-W	23284	CGA-EC-W	23304
1/4"	5/8"	-	-	-	-	CIA-W	23285	CIA-EC-W	23305
1/4"	3/4"	-	-	-	-	CJA-W	23286	CJA-EC-W	23306
1/4"	1"	CLA	22939	CLA-EC	22969	CLA-W	23287	CLA-EC-W	23307
1/4"	1-1/2"	CPA	22940	CPA-EC	22970	-	-	-	-
1/4"	1-3/4"	CRA	22941	CRA-EC	22971	-	-	-	-
5/16"	3/4"	-	-	-	-	DJA-W	23288	DJA-EC-W	23308
5/16"	1"	DLA	22942	DLA-EC	22972	DLA-W	23289	DLA-EC-W	23309
3/8"	3/4"	EJA	22943	EJA-EC	22973	EJA-W	23290	EJA-EC-W	23310
3/8"	1"	ELA	22944	ELA-EC	22974	ELA-W	23291	ELA-EC-W	23311
3/8"	1-1/2"	EPA	22945	EPA-EC	22975	EPA-W	23292	EPA-EC-W	23312
3/8"	2"	ESA	22946	ESA-EC	22976	-	-	-	-
7/16"	1"	FLA	22947	FLA-EC	22977	FLA-W	23293	FLA-EC-W	23313
1/2"	1/2"	GGA	22948	GGA-EC	22978	-	-	-	-
1/2"	1"	GLA	22949	GLA-EC	22979	GLA-W	23294	GLA-EC-W	23314
1/2"	1-1/4"	GNA	22950	GNA-EC	22980	-	-	-	-
1/2"	1-1/2"	GPA	22951	GPA-EC	22981	-	-	-	-
1/2"	2"	GSA	22952	GSA-EC	22982	-	-	-	-
5/8"	1"	ILA	22953	ILA-EC	22983	ILA-W	23295	ILA-EC-W	23315
3/4"	1/2"	JGA	22954	JGA-EC	22984	JGA-W	23296	JGA-EC-W	23316
3/4"	3/4"	JJA	22955	JJA-EC	22985	JJA-W	23297	JJA-EC-W	23317
3/4"	1"	JLA	22956	JLA-EC	22986	JLA-W	23298	JLA-EC-W	23318
3/4"	1-1/4"	JNA	22957	JNA-EC	22987	-	-	-	-
7/8"	1"	-	-	-	-	-	-	-	-
1"	1/4"	LCA	22958	LCA-EC	22988	-	-	-	-
1"	1"	LLA	22959	LLA-EC	22989	LLA-W	23299	LLA-EC-W	23319

Severance® Tool Industries, Inc.
Manufactures Code 662018
Website: www.severancetool.com



Phone: 989-777-5500 Fax: 989-777-0602

E-Mail: severancetool@sbcglobal.net

Severance Tool Industries Inc. • POB 1866 • Saginaw, MI 48605

Shape A Midget Mills®

Carbide Midget Mills® are for operations in rigid environments where chatter is minimized and tool control is high. Severance uses special grades of carbide, which are formulated by custom suppliers and sintered at the Severance plant. The carbide is a special blend of Tungsten and Cobalt. These custom grades have been selected because they hold a fine cutting edge, which can be reground many times before the tool is used up. Carbide may be operated at many times the speed of steel tools and generally yields as much as five to ten times the service life. Carbide Midget Mills® have a Spiral tooth pattern; Carbo-Mills™ have a Double Cut tooth pattern; and carbide Sever-Cuts™ have a Super Coarse tooth Pattern.



H.S.S. and Carbide Midget Mills®
Come with 1/4" shanks



Head Dia.	Flute Length	Carbide Carbo-Mill™ Double Cut		Carbide Carbo-Mill™-EC Double Cut		Carbide Sever-Cut™ Super Coarse	
		Carbo-Mill™ Name	EDP Order Number	Carbo-Mill™ End Cut Name	EDP Order Number	Sever-Cut™ Name	EDP Order Number
1/8"	1/2"	8A4-W	22380	8A4-EC-W	22386	-	-
1/8"	5/8"	8AI4L-W	22381	8AI4L-EC-W	22387	-	-
1/8"	3/4"	-	-	-	-	-	-
1/8"	1"	-	-	-	-	-	-
1/8"	1-1/4"	-	-	-	-	-	-
1/8"	1-1/2"	-	-	-	-	-	-
5/32"	5/8"	8A5-W	22382	8A5-EC-W	22388	-	-
3/16"	1/2"	-	-	-	-	-	-
3/16"	5/8"	8A6-W	22383	8A6-EC-W	22389	-	-
3/16"	3/4"	-	-	-	-	-	-
3/16"	1"	-	-	-	-	-	-
1/4"	1/2"	-	-	-	-	-	-
1/4"	5/8"	8A-W	22384	8A-EC-W	22390	-	-
1/4"	3/4"	-	-	-	-	CJA-W-4F	23680
1/4"	1"	8AL-W	22385	8AL-EC-W	22391	-	-
1/4"	1-1/2"	-	-	-	-	-	-
1/4"	1-3/4"	-	-	-	-	-	-
5/16"	3/4"	10A8-W	22480	10A8-EC-W	22496	-	-
5/16"	1"	10LA8-W	22481	10LA8-EC-W	22497	-	-
3/8"	3/4"	12A8-W	22482	12A8-EC-W	22498	EJA-W-6F	23681
3/8"	1"	12LA8-W	22483	12LA8-EC-W	22499	-	-
3/8"	1-1/2"	12XA8-W	22484	12XLA8-EC-W	22500	-	-
3/8"	2"	-	-	-	-	-	-
7/16"	1"	14A8-W	22485	14A8-EC-W	22501	-	-
1/2"	1/2"	-	-	-	-	-	-
1/2"	1"	16A8-W	22486	16A8-EC-W	22502	GLA-W-8F	23682
1/2"	1-1/4"	-	-	-	-	-	-
1/2"	1-1/2"	-	-	-	-	-	-
1/2"	2"	-	-	-	-	-	-
5/8"	1"	20A8-W	22487	20A8-EC-W	22503	ILA-W-8F	23683
3/4"	1/2"	24GA8-W	22488	24GA8-EC-W	22504	-	-
3/4"	3/4"	24JA8-W	22489	24JA8-EC-W	22505	-	-
3/4"	1"	24A8-W	22490	24A8-EC-W	22506	JLA-W-8F	23684
3/4"	1-1/4"	-	-	-	-	-	-
7/8"	1"	28A8-W	22492	28A8-EC-W	22508	-	-
1"	1/4"	-	-	-	-	-	-
1"	1"	32A8-W	22494	32A8-EC-W	22510	-	-

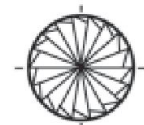

End Cut View
Available as an option
on many shapes.



Chip breaker used on HSS
Midget Mills®

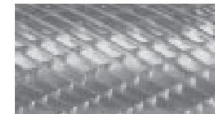

Double cut used on
Carbo-Mills™



Spiral used on carbide
Midget Mills® and
Ecarbo-Mills™



Super coarse cut used on
Sever-Cuts™

Severance Tool Industries, Inc.
Manufactures Code 662018
Website: www.severancetool.com



Phone: 989-777-5500 Fax: 989-777-0602

E-Mail: severancetool@sbcglobal.net

Severance Tool Industries Inc. • POB 1866 • Saginaw, MI 48605

Shape B Midget Mills®

Carbide tools have a full radius that blends to the shank, where as the H.S.S. tools have a 20° with C/L reverse angle on the back side of the cutting head.

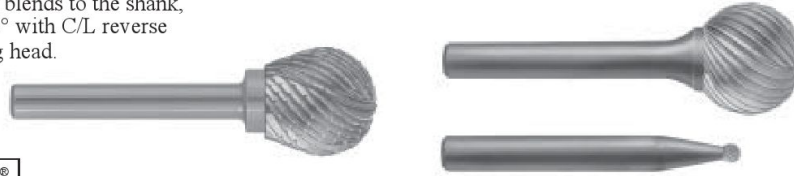

H.S.S. and Carbide Midget Mills®
Come with 1/4" shanks

Head Dia.	Flute Length	H.S.S. Midget-Mill® Single Cut Chip Breakers		Carbide Midget-Mill® Single Cut		Carbide Carbo-Mill™ Double Cut		Carbide Sever-Cut™ Super Coarse	
		Midget Mill® Name	EDP Order Number	Midget Mill® Name	EDP Order Number	Carbo-Mill™ Name	EDP Order Number	Sever-Cut™ Name	EDP Order Number
1/8"	3/32"	AAB	22990	AAB-W	23320	8B4-W	22392	-	-
3/16"	11/64"	BBB	22991	BBB-W	23321	8B6-W	22393	-	-
1/4"	3/16"	CCB	22992	CCB-W	23322	8B-W	22394	CCB-W-4F	23685
5/16"	1/4"	DDB	22993	DDB-W	23323	10B8-W	22512	-	-
3/8"	5/16"	EEB	22994	EEB-W	23324	12B8-W	22513	EEB-W-6F	23686
7/16"	3/8"	FFB	22995	FFB-W	23325	14B8-W	22514	-	-
1/2"	7/16"	GGB	22996	GGB-W	23326	16B8-W	22515	GGB-W-8F	23687
9/16"	1/2"	HHB	22997	-	-	-	-	-	-
5/8"	9/16"	IIB	22998	IIB-W	23327	20B8-W	22516	IIB-W-8F	23688
3/4"	11/16"	JJB	22999	JJB-W	23328	24B8-W	22517	JJB-W-8F	23689
7/8"	13/16"	KKB	23000	-	-	-	-	-	-
1"	15/16"	LLB	23001	LLB-W	23329	32B8-W	22519	-	-
1-1/4"	1-3/16"	NNB	23002	-	-	-	-	-	-

Flex-Shank Midget Mills®



Many cases of puzzling, inside, blind, interrupted, winding, and around the corner, cleaning and deburring problems have been solved with Severance FLEX-SHANK Midget Mills®. We would like to help you! Submit details - sample parts if feasible. See pages 91-96 for more on special tools.



REF. # 53999



Phone: 989-777-5500 Fax: 989-777-0602





E-Mail: severancetool@sbcglobal.net

Severance Tool Industries Inc. • POB 1866 • Saginaw, MI 48605

Shape C Midget Mills®

Cylindrical shape mills with full radius end.
Radius on end is one-half of tool diameter.



		 H.S.S. Midget-Mill® Single Cut Chip Breakers		 Carbide Midget-Mill® Single Cut		 Carbide Carbo-Mill™ Double Cut		 Carbide Sever-Cut™ Super Coarse	
Head Dia.	Flute Length	Midget Mill® Name	EDP Order Number	Midget Mill® Name	EDP Order Number	Carbo-Mill™ Name	EDP Order Number	Sever-Cut™ Name	EDP Order Number
1/8"	1/2"	AGC	23003	AGC-W	23330	8C4-W	22395	-	-
1/8"	5/8"	-	-	AIC-W	23331	8CI4L-W	22396	-	-
5/32"	5/8"	-	-	-	-	8C5-W	22413	-	-
3/16"	1/2"	BGC	23004	-	-	-	-	-	-
3/16"	5/8"	-	-	BIC-W	23332	8C6-W	22397	-	-
1/4"	1/2"	-	-	CGC-W	23333	-	-	-	-
1/4"	5/8"	-	-	CIC-W	23334	8C-W	22414	CJC-W-4F	23690
1/4"	3/4"	-	-	-	-	-	-	-	-
1/4"	1"	CLC	23005	CLC-W	23335	8LC-W	22398	-	-
1/4"	1-1/2"	CPC	23006	-	-	-	-	-	-
1/4"	2-1/2"	CUC	23007	-	-	-	-	-	-
5/16"	3/4"	-	-	DJC-W	23336	10C8-W	22521	-	-
5/16"	1"	DLC	23008	DLC-W	23337	10LC8-W	22522	-	-
3/8"	3/4"	-	-	EJC-W	23338	12C8-W	22523	EJC-W-6F	23691
3/8"	1"	ELC	23009	ELC-W	23339	12MC8-W	22524	-	-
3/8"	1-1/2"	EPC	23010	EPC-W	23340	12LC8-W	22525	-	-
7/16"	1"	FLC	23011	FLC-W	23341	14C8-W	22526	-	-
1/2"	1"	GLC	23012	GLC-W	23342	16C8-W	22527	GLC-W-8F	23692
1/2"	1-1/2"	GPC	23013	-	-	-	-	-	-
5/8"	1"	ILC	23014	ILC-W	23343	20C8-W	22528	ILC-W-8F	23693
3/4"	1/2"	-	-	-	-	24GC8-W	22529	-	-
3/4"	3/4"	-	-	JLC-W	23344	24MC8-W	22531	-	-
3/4"	1"	JLC	23015	-	-	24C8-W	22533	JLC-W-8F	23694
3/4"	1-1/4"	JNC	23016	-	-	-	-	-	-
3/4"	1-1/2"	JPC	23017	-	-	-	-	-	-
1"	1"	-	-	-	-	32C8-W	22535	-	-
1	1-3/8"	LOC	23018	-	-	-	-	-	-

Shape D Midget Mills®

Cylindrical shape mills with corner radius.

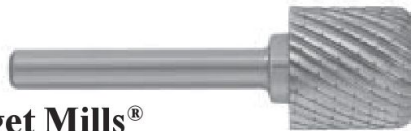

		 H.S.S. Midget-Mill® Single Cut Chip Breakers	
Head Dia.	Flute Length	Midget Mill® Name	EDP Order Number
1/2"	1/2"	GGD-1/32R	23019
1/2"	1/2"	GGD-1/16R	23020
1/2"	1/2"	GGD-3/32R	23021
1/2"	1/2"	GGD-1/8 R.	23022
3/4"	3/4"	JJD-1/16R	23023
3/4"	3/4"	JJD-1/8R	23024
3/4"	3/4"	JJD-3/16R	23025
3/4"	3/4"	JJD-1/4R	23026



Severance Tool Industries, Inc.
Manufactures Code 662018
Website: www.severancetool.com



Phone: 989-777-5500 Fax: 989-777-0602

E-Mail: severancetool@sbcglobal.net

Severance Tool Industries Inc. • POB 1866 • Saginaw, MI 48605

Shape E Midget Mills®

Cone shape mills having 20° C/L angle.



 H.S.S. Midget-Mill® Single Cut Chip Breakers

Head Dia.	Flute Length	Nose Pointed (P) or Radius	Midget Mill® Name	EDP Order Number
1/8"	3/16"	P	ABE	23080
3/16"	3/16"	1/32"	BBE	23081
1/4"	5/16"	P	CDE	23082
3/8"	1/2"	P	EGE	23083
1/2"	3/8"	5/32"	GEE	23084
1/2"	1/2"	3/32"	GGE	23085
3/4"	3/4"	9/64	JJE	23086

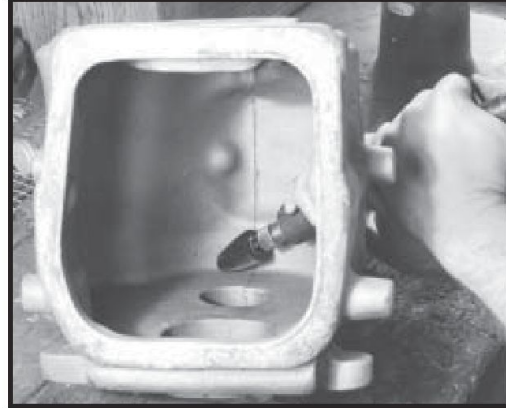

Shape F Midget Mills®

Cone shape mills having 18° C/L angle.

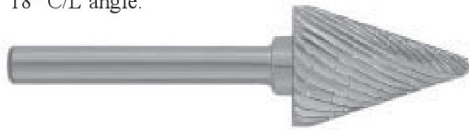

H.S.S. and Carbide Midget Mills®
Come with 1/4" shanks

 H.S.S. Midget-Mill® Single Cut Chip Breakers

 Carbide Midget-Mill® Single Cut

 Carbide Carbo-Mill™ Double Cut

Head Dia.	Flute Length	Midget Mill® Name	EDP Order Number	Midget Mill® Name	EDP Order Number	Carbo-Mill™ Name	EDP Order Number
5/16"	3/8"	DEF	23087	-	-	-	-
3/8"	3/8"	EEF	23088	-	-	-	-
3/8"	9/16"	EHF	23089	-	-	-	-
1/2"	7/16"	GFF	23090	-	-	-	-
1/2"	5/8"	GIF	23091	-	-	-	-
5/8"	3/4"	IJF	23092	-	-	-	-
5/8"	7/8"	IKF	23093	IKF-W	23410	20F8-W	22583
3/4"	7/8"	JKF	23094	-	-	-	-
3/4"	1"	JLF	23095	-	-	-	-
1"	1"	LLF	23096	-	-	-	-
1"	1-3/8"	LOF	23097	-	-	-	-



Phone: 989-777-5500 Fax: 989-777-0602

E-Mail: severancetool@sbcglobal.net

Severance Tool Industries Inc. • POB 1866 • Saginaw, MI 48605



Shape G Midget Mills®

Cone shape mills having
16° C/L angle.



H.S.S.
Midget-Mill®
Single Cut
Chip Breakers

Head Dia.	Flute Length	Nose Pointed (P) or Radius	Midget Mill® Name	EDP Order Number
1/8"	3/16"	P	ABG	23098
5/16"	3/8"	1/16"	DEG	23099
3/8"	7/16"	5/64"	EFG	23100
3/8"	5/8"	1/64"	EIG	23101
1/2"	1/2"	5/32"	GGG	23102
5/8"	3/4"	1/8"	IJG	23103
3/4"	3/4"	7/32"	JJG	23104



REF. # 55339

Midget Mills® with Special Guides

Midget Mills® are available in different Shapes, Sizes, and lengths of cut.

Shape H Midget Mills®

Cone shape mills having
14° C/L angle.



H.S.S.
Midget-Mill®
Single Cut
Chip Breakers



Carbide
Midget-Mill®
Single Cut



Carbide
Carbo-Mill™
Double Cut

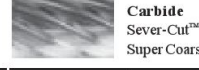

Carbide
Sever-Cut™
Super Coarse

Head Dia.	Flute Length	Nose Pointed (P) or Radius	Midget Mill® Name	EDP Order Number	Midget Mill® Name	EDP Order Number	Carbo-Mill™ Name	EDP Order Number	Sever-Cut™ Name	EDP Order Number
3/16"	5/16"	P	BDH	23105	—	—	—	—	—	—
1/4"	3/8"	P	—	—	CEH-W	23400	—	—	—	—
1/4"	1/2"	P	CGH	23107	—	—	8H-W	22405	—	—
5/16"	5/8"	P	DIH	23106	—	—	—	—	—	—
3/8"	1/2"	5/64"	EGH	23108	—	—	—	—	—	—
3/8"	5/8"	.073 FLAT	—	—	—	—	12H8-W	22581	—	—
3/8"	3/4"	P	EJH	23109	EJH-W	23407	—	—	—	—
1/2"	9/16"	9/64"	GHH	23110	—	—	—	—	—	—
1/2"	7/8"	1/32"	GKH	23111	GKH-W	23408	16H8-W	22582	GKH-W-8F	23710
5/8"	3/4"	5/32"	IJH	23112	—	—	—	—	—	—



Shape I Midget Mills®

Cone shape mills having
12° C/L angle.



H.S.S.
Midget-Mill®
Single Cut
Chip Breakers

Head Dia.	Flute Length	Nose Pointed (P) or Radius	Midget Mill® Name	EDP Order Number
1/4"	5/16"	1/16"	CDI	23113
3/8"	1/2"	3/32"	EGI	23114
3/8"	3/4"	1/32"	EJI	23115
1/2"	5/8"	9/64"	GII	23116
1/2"	1"	3/64"	GLI	23117
5/8"	3/4"	3/16"	IJI	23118
3/4"	9/16"	5/16"	JHI	23119



REF. # 55337

Extra Large Midget Mills

Midget Mills® are available in different shapes, sizes, and lengths of cut. Such as this large 4" diameter by 8" long Midget Mill®.

Severance Tool Industries, Inc.

Manufactures Code 662018

Website: www.severancetool.com



Phone: 989-777-5500 Fax: 989-777-0602

E-Mail: severancetool@sbcglobal.net

Severance Tool Industries Inc. • POB 1866 • Saginaw, MI 48605

Shape J Midget Mills®

Cone shape mills having 10° C/L angle.



H.S.S. Midget-Mill® Single Cut Chip Breakers

Carbide Midget-Mill® Single Cut

Head Dia.	Flute Length	Nose Pointed (P) or Radius	Midget Mill® Name	EDP Order Number	Midget Mill® Name	EDP Order Number
3/16"	3/8"	1/32"	BEJ	23120	—	—
1/4"	5/16"	5/64"	CDJ	23121	—	—
1/4"	1/2"	3/64"	CGJ	23122	CGJ-W	23401
5/16"	3/4"	1/32"	DJJ	23123	—	—
3/8"	1/2"	1/8"	EGJ	23124	—	—
3/4"	5/8"	5/16"	JIJ	23125	—	—
3/4"	1"	7/32"	JLJ	23126	—	—
1"	3/4"	7/16"	LJJ	23128	—	—
1"	2-5/8"	1/16"	LUJ	23127	—	—

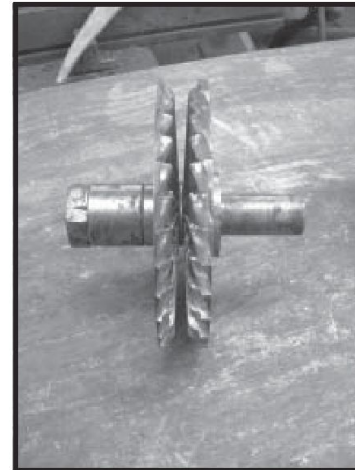

REF. # 55493

Here is an example of a larger milling cutter made by Severance to use in our milling department to put a special form on a standard tool.

Shape K Midget Mills®

Cone shape mills having 8-1/2° C/L angle.



H.S.S. Midget-Mill® Single Cut Chip Breakers

Head Dia.	Flute Length	Nose Pointed (P) or Radius	Midget Mill® Name	EDP Order Number
1/8"	3/8"	P	AEK	23129
1/4"	3/8"	5/64"	CEK	23130
1/4"	5/8"	1/32"	CIK	23132
1/4"	3/4"	P	CJK	23131
5/16"	3/4"	3/64"	DJK	23133
3/8"	1"	3/64"	ELK	23134
1/2"	1-1/4"	1/16"	GNK	23135



REF.#51916

Special Flute Geometry

This cutter has a Herringbone cut on it. Tool used to deburr automotive universal joints.

Shape L Midget Mills®

Cone shape mills having 7° C/L angle.



H.S.S. Midget-Mill® Single Cut Chip Breakers

Carbide Midget-Mill® Single Cut

Carbide Carbo-Mill™ Double Cut

Carbide Sever-Cut™ Super Coarse

Head Dia.	Flute Length	Nose Pointed (P) or Radius	Midget Mill® Name	EDP Order Number	Midget Mill® Name	EDP Order Number	Carbo-Mill™ Name	EDP Order Number	Sever-Cut™ Name	EDP Order Number
3/16"	5/8"	1/64"	BIL	23136	—	—	—	—	—	—
1/4"	3/8"	.089"	—	—	—	—	8PL-W	22406	—	—
1/4"	5/8"	.055"	—	—	—	—	8LR-W	22408	—	—
1/4"	3/4"	1/32"	CJL	23137	CJL-W	23402	—	—	—	—
5/16"	3/4"	1/16"	DJL	23138	—	—	—	—	—	—
5/16"	7/8"	.055"	—	—	DKL-W	23405	10L8-W	22574	—	—
3/8"	1"	1/16"	ELL	23139	ELL-W	23406	12L8-W	22575	ELL-W-6F	23705
1/2"	1-1/8"	1/8"	—	—	—	—	16L8-W	22576	GML-W-8F	23706
1/2"	1-1/4"	3/32"	GNL	23140	GNL-W	23409	—	—	—	—
5/8"	3/4"	15/64"	IIL	23141	—	—	—	—	—	—
5/8"	7/8"	7/32"	IKL	23142	—	—	—	—	—	—
5/8"	1"	7/32"	—	—	—	—	20L8-W	22580	—	—
5/8"	1-3/16"	3/16"	—	—	—	—	20SL8-W	22577	INL-W-8F	23707
5/8"	1-5/16"	.171	—	—	—	—	20LL8-W	22578	IOL-W-8F	23708
3/4"	1-1/2"	7/32"	—	—	—	—	24L8-W	22579	JPL-W-8F	23709



Phone: 989-777-5500 Fax: 989-777-0602
 E-Mail: severancetool@sbcglobal.net

Severance Tool Industries Inc. • POB 1866 • Saginaw, MI 48605



Shape M Midget Mills®

Cone shape mills having 5° C/L angle.



Head Dia.	Flute Length	Nose Pointed (P) or Radius	H.S.S. Midget-Mill® Single Cut Chip Breakers		Carbide Midget-Mill® Single Cut	
			Midget Mill® Name	EDP Order Number	Midget Mill® Name	EDP Order Number
1/8"	1/2"	P	AGM	23143	—	—
3/16"	3/4"	1/32"	BJM	23144	—	—
1/4"	7/8"	3/64"	CKM	23145	CKM-W	23403
1/4"	1-1/4"	1/64"	CNM	23146	CNM-W	23404
3/8"	1"	7/64"	ELM	23147	—	—
3/8"	1-3/4"	1/32"	ERM	23148	—	—
1/2"	3/4"	13/64"	GJM	23149	—	—
1/2"	1"	5/32"	GLM	23150	—	—
1/2"	1-1/4"	5/32"	GNM	23151	—	—



REF. # 55494
 Here is an example of a larger milling cutter made by Severance to use in our milling department to put a special form on a standard tool.

H.S.S. and Carbide Midget Mills®
 Come with 1/4" shanks

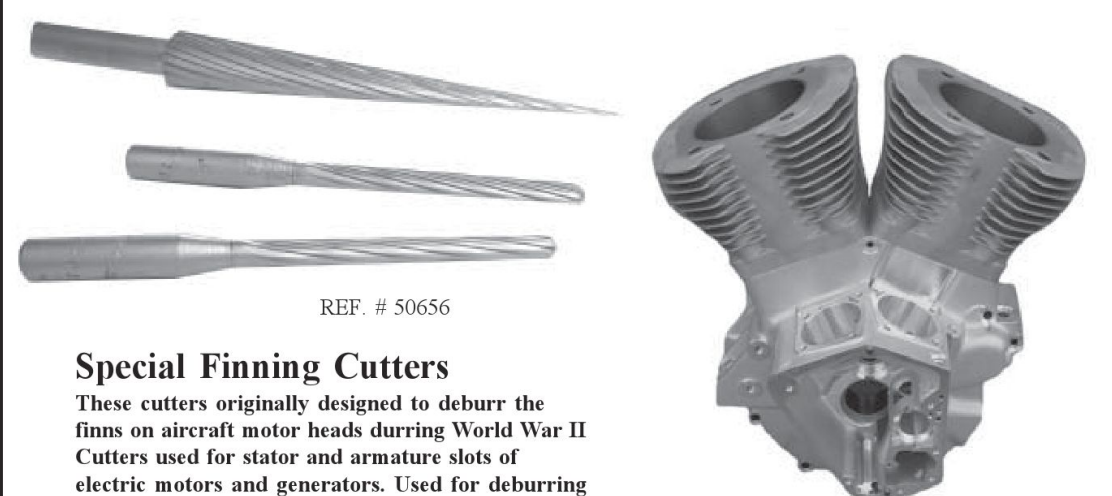

REF. # 50656

Special Finning Cutters

These cutters originally designed to deburr the fins on aircraft motor heads during World War II. Cutters used for stator and armature slots of electric motors and generators. Used for deburring in confined areas that are hard to reach.

Severance® Tool Industries, Inc.
 Manufactures Code 662018
 Website: www.severancetool.com



Phone: 989-777-5500 Fax: 989-777-0602

E-Mail: severancetool@sbcglobal.net

Severance Tool Industries Inc. • POB 1866 • Saginaw, MI 48605

Shape N Midget Mills®

Inverted Cone shape mills having 5° to 18° C/L angle. Most commonly used without optional end cut.

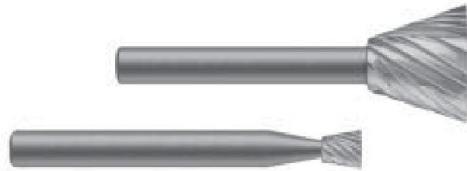

Here is an example of a larger inverted cone milling cutter also made by Severance to use in our milling department to put flutes in a standard tool.

REF. #55523

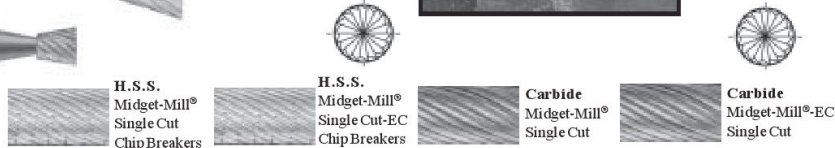

Head Dia.	Flute Length	Included Angle	Midget Mill® Name	EDP Order Number	Midget Mill® End Cutting Name	EDP Order Number	Midget Mill® End Cutting Name	EDP Order Number	Midget Mill® End Cutting Name	EDP Order Number
1/4"	1/8"	36°	CAN	23152	CAN-EC	23169	-	-	-	-
1/4"	3/16"	28°	CBN	23153	CBN-EC	23170	-	-	-	-
1/4"	1/4"	20°	CCN	23154	CCN-EC	23171	-	-	-	-
1/4"	3/8"	14°	CEN	23155	CEN-EC	23172	-	-	-	-
1/4"	3/8"	20°	-	-	-	-	CEN-W	23411	CEN-W-EC	23416
1/4"	1/2"	10°	CGN	23156	CGN-EC	23173	-	-	-	-
3/8"	3/16"	36°	EBN	23157	EBN-EC	23174	-	-	-	-
3/8"	1/4"	28°	ECN	23158	ECN-EC	23175	-	-	-	-
3/8"	5/16"	20°	EDN	23159	EDN-EC	23176	EDN-W	23412	EDN-W-EC	23417
3/8"	3/8"	13°	-	-	-	-	-	-	-	-
3/8"	1/2"	10°	EGN	23160	EGN-EC	23177	-	-	-	-
1/2"	3/8"	20°	GEN	23161	GEN-EC	23178	-	-	-	-
1/2"	1/2"	14°	GGN	23162	GGN-EC	23179	-	-	-	-
1/2"	1/2"	16°	-	-	-	-	GGN-W	23413	GGN-W-EC	23418
1/2"	1/2"	28°	-	-	-	-	-	-	-	-
1/2"	1"	14°	GLN	23163	GLN-EC	23180	-	-	-	-
1/2"	1-1/8"	10°	GMN	23164	GMN-EC	23181	-	-	-	-
5/8"	3/8"	36°	IEN	23165	IEN-EC	23182	IEN-W	23414	IEN-W-EC	23419
5/8"	1/2"	28°	IGN	23166	IGN-EC	23183	-	-	-	-
5/8"	3/4"	18°	-	-	-	-	-	-	-	-
3/4"	1/2"	36°	JGN	23167	JGN-EC	23184	JGN-W	23415	JGN-W-EC	23420
3/4"	5/8"	30°	-	-	-	-	-	-	-	-
3/4"	5/8"	36°	JIN	23168	JIN-EC	23185	-	-	-	-
3/4"	3/4"	21°	-	-	-	-	-	-	-	-

REF. # 55354

REF. # 55373
Here is an example of a larger milling cutter made by Severance. The tool was 3" diameter by 4" length of cut.

Special Extra Length Midget Mills
Midget Mills® are available in diferent shapes, sizes, and lengths of cut.

Severance® Tool Industries, Inc.
Manufactures Code 662018
Website: www.severancetool.com



Phone: 989-777-5500 Fax: 989-777-0602

E-Mail: severancetool@sbcglobal.net

Severance Tool Industries Inc. • POB 1866 • Saginaw, MI 48605

Shape N Midget Mills®

Inverted Cone shape mills having 5° to 18° C/L angle. Most commonly used without optional end cut.

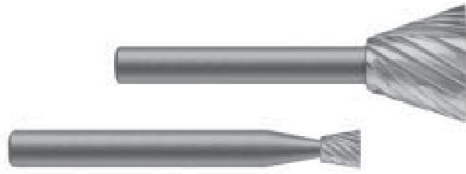

Inside Hole Deburring Cutters

Inside Hole - Place cutter head inside hole, bring back against inner wall edge; follow around inner contour of hole letting the shank act as a guide.

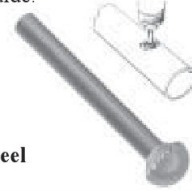

High Speed Steel

Inside Style

Cutting Dia.	Neck Dia.	Shank Dia.	Severance Tool Name	EDP Order Number
7/32"	.109"	1/4"	7/32-IAD	35660
1/4"	.125"	1/4"	1/4-IAD	35661
5/16"	.156"	1/4"	5/16-IAD	35662
3/8"	.187"	1/4"	3/8-IAD	35663
7/16"	.250"	1/4"	7/16-IAD	35664
1/2"	.250"	1/4"	1/2-IAD	35665



Head Dia.	Flute Length	Included Angle	Carbo-Mill™ Double Cut		Carbo-Mill™ Double Cut-EC	
			Double Cut Name	EDP Order Number	Double Cut-EC Name	EDP Order Number
1/4"	1/8"	36°	-	-	-	-
1/4"	3/16"	28°	8N-W	22409	8N-W-EC	22410
1/4"	1/4"	20°	-	-	-	-
1/4"	3/8"	14°	-	-	-	-
1/4"	3/8"	20°	-	-	-	-
1/4"	1/2"	10°	-	-	-	-
3/8"	3/16"	36°	-	-	-	-
3/8"	1/4"	28°	-	-	-	-
3/8"	5/16"	20°	-	-	-	-
3/8"	3/8"	13°	12N8-W	22584	12N8-W-EC	22588
3/8"	1/2"	10°	-	-	-	-
1/2"	3/8"	20°	-	-	-	-
1/2"	1/2"	14°	-	-	-	-
1/2"	1/2"	16°	-	-	-	-
1/2"	1/2"	28°	16N8-W	22585	16N8-W-EC	22589
1/2"	1"	14°	-	-	-	-
1/2"	1-1/8"	10°	-	-	-	-
5/8"	3/8"	36°	-	-	-	-
5/8"	1/2"	28°	-	-	-	-
5/8"	3/4"	18°	20N8-W	22586	20N8-W-EC	22590
3/4"	1/2"	36°	-	-	-	-
3/4"	5/8"	30°	24N8-W	22587	24N8-W-EC	22591
3/4"	5/8"	36°	-	-	-	-
3/4"	3/4"	21°	24JN8-W	22545	24JN8-W-EC	22592

Tangent/Hole Deburring Cutters

Outside Hole -Place cutter in hole at right angle to tubing length. Geometrically (for any size hole) the diameter of the tool and the outside diameter of the part should be equal.



High Speed Steel

Outside Style

Cutting Dia.	Cutting Length	Shank Dia.	Severance Tool Name	EDP Order Number
5/16"	1"	1/4"	DLA-LHS	35666
3/8"	1"	1/4"	ELA-LHS	35667
1/2"	1/2"	1/4"	GGA-LHS	35668
5/8"	1"	1/4"	ILA-LHS	35669
3/4"	3/4"	1/4"	JJA-LHS	35670
1"	1"	1/4"	LLA-LHS	35671

H.S.S. and Carbide Midget Mills®
Come with 1/4" shanks

Special Flute Geometry

Special flute geometry is used on this cutter to cut wafered cardboard.



REF. # 51926

Severance Tool Industries, Inc.
Manufactures Code 662018
Website: www.severancetool.com



Phone: 989-777-5500 Fax: 989-777-0602

E-Mail: severancetool@sbcglobal.net

Severance Tool Industries Inc. • POB 1866 • Saginaw, MI 48605

Shape P Midget Mills®

Pear shape mills with small end forward.



H.S.S. Midget-Mill® Single Cut Chip Breakers

Head Dia.	Flute Length	Midget Mill® Name	EDP Order Number
1/4"	5/16"	CDP	23027
5/16"	3/8"	DEP	23028
3/8"	7/16"	EFP	23029
1/2"	5/8"	GIP	23030
5/8"	1"	ILP	23031



H.S.S. and Carbide Midget Mills®
Come with 1/4" shanks

Shape Q Midget Mills®

The very useful olive-shaped mills.



H.S.S. Midget-Mill® Single Cut Chip Breakers

Head Dia.	Flute Length	Midget Mill® Name	EDP Order Number
3/16"	5/16"	BDQ	23032
1/4"	3/8"	—	—
1/4"	7/16"	CFQ	23033
5/16"	1/2"	DGQ	23034
3/8"	5/8"	EIQ	23035
3/8"	3/4"	EJQ	23036
7/16"	1"	—	—
1/2"	7/8"	GKQ	23037
5/8"	1"	ILQ	23038
3/4"	1"	JLQ	23039
1"	1-3/8"	LOQ	23040



Carbide Midget-Mill® Single Cut

Midget Mill® Name	EDP Order Number
BDQ-W	23372
CEQ-W	23373
—	—
—	—
EIQ-W	23374
—	—
—	—
GKQ-W	23375
ILQ-W	23376
JLQ-W	23377
—	—

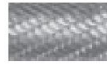

Carbide Carbo-Mill™ Double Cut

Carbo-Mill™ Name	EDP Order Number
8Q6-W	22399
8Q-W	22400
—	—
—	—
12Q8-W	22537
—	—
14Q8-W	22538
16Q8-W	22540
20Q8-W	22541
24Q8-W	22542
32Q8-W	22544



Carbide Sever-Cut™ Super Coarse

Sever-Cut™ Name	EDP Order Number
—	—
—	—
—	—
—	—
EIQ-W-6F	23695
—	—
—	—
GKQ-W-8F	23696
ILQ-W-8F	23697
JLQ-W-8F	23698
—	—

REF.#55382

REF.#55373

Special Shaped Midget Mills

Midget Mills® are available in different shapes, sizes, and lengths of cut.



Phone: 989-777-5500 Fax: 989-777-0602
 E-Mail: severancetool@sbcglobal.net

Severance Tool Industries Inc. • POB 1866 • Saginaw, MI 48605



Shape R Midget Mills®
 Tree-shape mills with rounded noses.

H.S.S. and Carbide Midget Mills®
 Come with 1/4" shanks

		H.S.S. Midget-Mill® Single Cut Chip Breakers		Carbide Midget-Mill® Single Cut		Carbide Carbo-Mill™ Double Cut		Carbide Sever-Cut™ Super Coarse	
Head Dia.	Flute Length	Midget Mill® Name	EDP Order Number	Midget Mill® Name	EDP Order Number	Carbo-Mill™ Name	EDP Order Number	Sever-Cut™ Name	EDP Order Number
1/8"	7/16"	AFR	23041	AFR-W	23345	-	-	-	-
1/8"	1/2"	-	-	-	-	8R4-W	22401	-	-
3/16"	5/16"	BDR	23042	-	-	-	-	-	-
3/16"	1/2"	BGR	23043	-	-	-	-	-	-
1/4"	3/8"	CER	23044	-	-	-	-	-	-
1/4"	1/2"	-	-	CGR-W	23346	-	-	-	-
1/4"	5/8"	-	-	CIR-W	23347	8R-W	22402	-	-
1/4"	3/4"	CJR	23045	CJR-W	23348	-	-	CJR-W-4F	23699
1/4"	1"	CLR	23046	-	-	-	-	-	-
5/16"	1"	-	-	DLR-W	23350	-	-	-	-
3/8"	7/16"	EFR	23047	-	-	-	-	-	-
3/8"	3/4"	EJR	23048	EJR-W	23349	12R8-W	22546	EJR-W-6F	23700
3/8"	1"	ELR	23049	-	-	-	-	-	-
7/16"	1"	-	-	-	-	14R8-W	22547	-	-
1/2"	3/4"	GJR	23078	GJR-W	23351	16JR8-W	22548	-	-
1/2"	1"	GLR	23050	GLR-W	23352	16R8-W	22549	GLR-W-8F	23701
1/2"	1-1/8"	GMR	23051	-	-	-	-	-	-
5/8"	5/8"	IIR	23052	-	-	-	-	-	-
5/8"	1"	-	-	ILR-W	23353	20R8-W	22550	ILR-W-8F	23702
5/8"	1-1/8"	IMR	23053	-	-	-	-	IMR-W-8F	23703
3/4"	3/4"	JJR	23054	-	-	-	-	-	-
3/4"	1"	JLR	23055	JLR-W	23354	24R8-W	22551	-	-
3/4"	1-1/4"	JNR	23056	JNR-W	23355	24NR8-W	22553	JNR-W-8F	23704
3/4"	1-1/2"	-	-	JPR-W	23356	24PR8-W	22554	-	-
3/4"	1-5/8"	JQR	23057	-	-	-	-	-	-
1"	1-3/8"	-	-	-	-	32R8-W	22555	-	-
1-1/8"	1-3/4"	MRR	23058	-	-	-	-	-	-
1-1/4"	2"	NSR	23059	-	-	-	-	-	-



Shape S Midget Mills®
 Tree shape mills with a small radius nose.

H.S.S. Midget-Mill® Single Cut Chip Breakers

Head Dia.	Flute Length	Severance Tool Name	EDP Order Number
1/8"	3/8"	AES	23060
3/16"	1/2"	BGS	23061
1/4"	3/4"	CJS	23062
3/8"	3/4"	EJS	23063
1/2"	1"	GLS	23064
5/8"	1-1/8"	IMS	23065
3/4"	1-1/4"	JNS	23066
1"	1-5/8"	LQS	23067
1-1/4"	2"	NSS	23068



Severance® Tool Industries, Inc.
 Manufactures Code 662018
 Website: www.severancetool.com



Phone: 989-777-5500 Fax: 989-777-0602

E-Mail: severancetool@sbcglobal.net

Severance Tool Industries Inc. • POB 1866 • Saginaw, MI 48605

Shape T Midget Mills®

Tree-shape mills with a pointed noses.



H.S.S. and Carbide Midget Mills®
Come with 1/4" shanks



H.S.S. Midget-Mill® Single Cut Chip Breakers

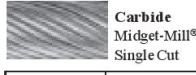

Carbide Midget-Mill® Single Cut



Carbide Carbo-Mill™ Double Cut

Head Dia.	Flute Length	Midget Mill® Name	EDP Order Number	Midget Mill® Name	EDP Order Number	Carbo-Mill™ Name	EDP Order Number
1/8"	1/2"	-	-	-	-	8T4-W	22403
1/4"	1/2"	CGT	23069	CGT-W	23357	-	-
1/4"	5/8"	-	-	CJT-W	23358	8T-W	22404
1/4"	3/4"	CJT	23070	CJT-W	23359	-	-
5/16"	3/4"	-	-	DJT-W	23360	10T8-W	22557
3/8"	5/8"	EIT	23701	-	-	-	-
3/8"	3/4"	EJT	23702	EJT-W	23361	12T8-W	22558
7/16"	1"	-	-	-	-	14T8-W	22559
1/2"	3/4"	GJT	23073	GJT-W	23362	16JT8-W	22560
1/2"	1"	GLT	23074	GLT-W	23363	16T8-W	22561
1/2"	1-1/8"	GMT	23075	-	-	-	-
5/8"	1"	ILT	23076	ILT-W	23364	20T8-W	22562
3/4"	1"	JLT	23077	JLT-W	23365	24T8-W	22563
3/4"	1-1/2"	-	-	JPT-W	23366	24PT8-W	22565
1"	1-3/8"	-	-	-	-	32T8-W	22567



REF.#55352

Coarse Cut Midget Mills®

Midget Mill® tools can be made in coarse cut for a variety of non-ferrous materials such as wood, aluminum, and certain plastics. Also see Sever-Cut™ Midget Mills® for non-ferrous materials.

Shape U Midget Mills®

Concave radius mills with cutting teeth on radius only.



H.S.S. Midget-Mill® Single Cut Chip Breakers



Carbide Midget-Mill® Single Cut



Carbide Carbo-Mill™ Double Cut

Head Dia.	Flute Length	Radius	Midget Mill® Name	EDP Order Number	Midget Mill® Name	EDP Order Number	Carbo-Mill™ Name	EDP Order Number
1/4"	1/8"	3/32"	CAU	23186	-	-	-	-
1/4"	3/16"	3/16"	CBU	23187	-	-	-	-
1/4"	1/8"	1/16"x4 PL	CZU	23188	-	-	-	-
5/16"	3/16"	3/32"	DBU	23189	-	-	-	-
3/8"	1/8"	1/16"	EAU	23190	-	-	-	-
3/8"	3/16"	1/8"	EBU	23191	-	-	-	-
3/8"	1/4"	3/16"	ECU	23192	-	-	-	-
3/8"	5/16"	1/4"	EDU	23193	-	-	-	-
7/16"	1/4"	5/32"	FCU	23194	-	-	-	-
1/2"	1/4"	3/16"	GCU	23195	GCU-W	23421	-	-
1/2"	5/16"	1/4"	GDU	23196	GDU-W	23422	-	-
1/2"	3/8"	5/16"	GEU	23197	GEU-W	23423	16U8-W	22556
1/2"	7/16"	3/8"	GFU	23198	GFU-W	23424	-	-
5/8"	1/2"	7/16"	IGU	23199	-	-	-	-
3/4"	3/8"	1/4"	JEU	23200	-	-	-	-
3/4"	7/16"	5/16"	JFU	23201	-	-	-	-
3/4"	1/2"	3/8"	JGU	23202	-	-	-	-
3/4"	5/8"	1/2"	JIU	23203	-	-	-	-
7/8"	5/8"	7/16"	KIU	23204	-	-	-	-
7/8"	3/4"	5/8"	KJU	23205	-	-	-	-



Phone: 989-777-5500 Fax: 989-777-0602
 E-Mail: severancetool@sbcglobal.net

Severance Tool Industries Inc. • P.O.R 1866 • Saginaw, MI 48605

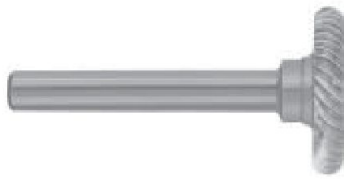

H.S.S. Midget-Mill® Single Cut Chip Breakers



Shape V Midget Mills®

Convex with cutting teeth on the radius only.

Head Dia.	Flute Length	Radius	Severance Tool Name	EDP Order Number
1/4"	3/8"	1/4"	CEV	23206
5/8"	7/16"	1/4"	IFV	23207
3/4"	1/2"	1/2"	JGV	23208
1"	3/16"	3/32"	LBV	23209
1-1/4"	7/8"	5/8"	NKV	23210

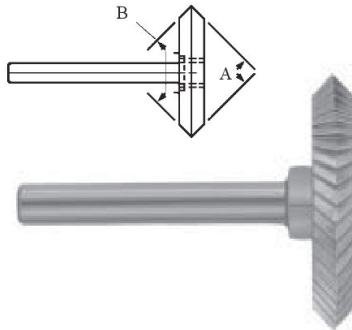

H.S.S. Midget-Mill® Single Cut Chip Breakers



Shape X Midget Mill®

Convex shape mills. This shape combines forward and reverse angles as listed in the "Included Angle" column. Forward angle is given first, followed by reverse angle. Angles are given with C/L. Special angles may be obtained at a nominal extra charge.

Head Dia.	Head Length	Centerline Angles		Severance Tool Name	EDP Order Number
		A	B		
1/4"	1/4"	20°	20°	CCX	23221
1/4"	3/8"	80°	10°	CEX	23217
5/16"	1/4"	30°	30°	DCX	23222
3/8"	1/4"	60°	60°	ECX	23223
1/2"	1/4"	50°	50°	GCX	23224
5/8"	1/4"	60°	60°	ICX	23225
5/8"	5/8"	40°	20°	IIX	23218
3/4"	1/2"	120°	60°	JGX	23219
1"	1/4"	90°	90°	LCX	23226
1"	3/4"	90°	30°	LJX	23220
1-1/2"	1/4"	60°	60°	PCX-30	23227
1-1/2"	1/4"	90°	90°	PCX-45	23228
1-1/2"	1/4"	120°	120°	PCX-60	23229



H.S.S. Midget-Mill® Single Cut Chip Breakers



Shape W Midget Mills®

Cylindrical shape mills with cutting teeth on the end radius only. They feature a non-fluted (safe) area at the center of the end face and on the straight cylindrical sides adjacent to the radius. Use for finishing fillets and many other similar applications.

Head Dia.	Flute Length	Radius	Severance Tool Name	EDP Order Number
1/4"	1/8"	1/16"	CAW	23211
5/16"	1/4"	1/16"	DCW	23212
3/8"	5/16"	3/32"	ECW	23213
1/2"	3/8"	5/32"	GEW	23214
7/8"	1/2"	1/4"	KGW	23215
1"	1/2"	5/16"	LGW	23216

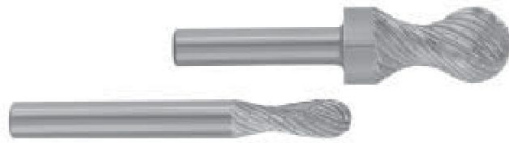

H.S.S. Midget-Mill® Single Cut Chip Breakers



Shape BI Midget Mills®

Convex with cutting teeth on the radius only.

Head Dia.	Flute Length	Radius	Severance Tool Name	EDP Order Number
3/16"	5/8"	5/16" x 1/2"	BIRU	23230
1/4"	3/4"	1-1/2" x 1/2"	CJCU	23231
1/4"	1"	3/4" x 3/4"	CLRU	23232
1/4"	1"	1" x 1/2"	CLTU	23233
5/16"	1-1/8"	1" x 1"	DMRU	23234
3/8"	1"	3/16" x 1-1/4"	ELCU	23235
3/8"	1"	1/2" x 3/4"	ELTU	23236
1/2"	7/8"	1/4" x 3/8"	GKCU	23237



Shape FL Midget Mills®

A very handy shape for blending operations.



Carbide Midget-Mill® Single Cut

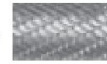

Carbide Carbo-Mill™ Double Cut

Head Dia.	Flute Length	Midget Mill® Name	EDP Order Number	Carbo-Mill™ Name	EDP Order Number
1/4"	5/8"	CIFL-W	23367	8GN-W	22415
5/16"	3/4"	DJFL-W	23368	10FL8-W	22569
1/2"	1-1/4"	GNFL-W	23369	16FL8-W	22570
5/8"	1-7/16"	IOFL-W	23370	20FL8-W	22571
3/4"	1-5/8"	JQFL-W	23371	24FL8-W	22572

Severance Tool Industries, Inc.
 Manufactures Code 662018
 Website: www.severancetool.com



Phone: 989-777-5500 Fax: 989-777-0602

E-Mail: severancetool@sbcglobal.net

Severance Tool Industries Inc. • POB 1866 • Saginaw, MI 48605

Long Shank Midget Mills®

1/4" Shank Diameter – 8" Shank Length

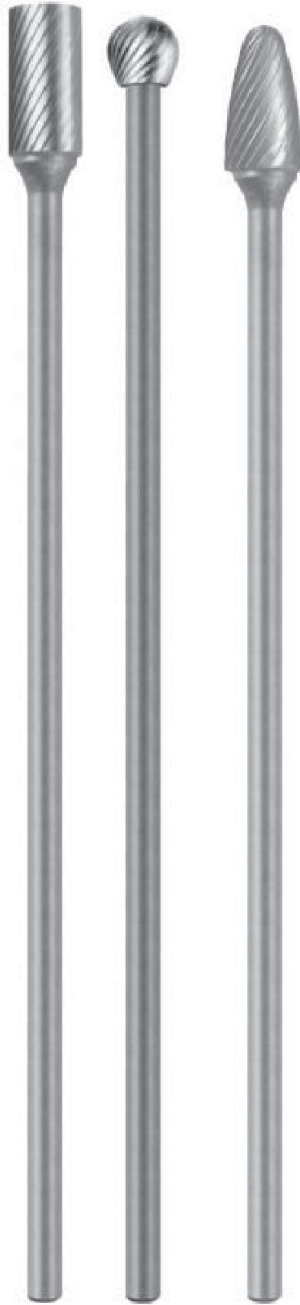

Other shank lengths available upon request



Special Flute Geometry

Special flute geometry is used on this cutter to deburr part.

REF. #51926



H.S.S. Midget-Mill®



Carbide Midget-Mill®

Head Dia.	Flute Length	Nose Point, Flat, or Radius
-----------	--------------	-----------------------------

Cylindrical, Plain Nose, Shape "A"

1/4"	1"	-
3/8"	1"	-
1/2"	1"	-

Cylindrical, End Cutting, Shape "A"

1/4"	1"	-
3/8"	1"	-
1/2"	1"	-

Ball, Shape "B"

1/4"	3/16"	-
3/8"	5/16"	-
1/2"	7/16"	-

Cylindrical, Ball Nose, Shape "C"

1/4"	1"	-
3/8"	1"	-
1/2"	1"	-

Tree, Radius Nose, Shape "R"

1/4"	1/2"	-
3/8"	3/4"	-
1/2"	1"	-

Tree, Pointed Nose, Shape "T"

1/4"	3/4"	P
3/8"	3/4"	P
1/2"	1"	P

Flame, Shape "FL"

5/16"	3/4"	-
1/2"	1-1/4"	-

Olive, Shape "Q"

1/4"	7/16"	-
3/8"	5/8"	-
1/2"	7/8"	-

Cone, 14° Included, Shape "L"

3/8"	1"	.063"
------	----	-------

Cone, 20° Included, Shape "J"

5/16"	3/4"	.031"
-------	------	-------

Cone, 28° Included, Shape "H"

1/4"	1/2"	P
1/2"	1"	F

Midget-Mill® Name	EDP Order Number
-------------------	------------------

CLAx8	23730
ELAx8	23731
GLAx8	23732

CLA-ECx8	23733
ELA-ECx8	23734
GLA-ECx8	23735

CCBx8	23736
EEBx8	23737
GBBx8	23738

CLCx8	23739
ELCx8	23740
GLCx8	23741

CJRx8	23742
EJRx8	23743
GLRx8	23744

CJTx8	23745
EJTx8	23746
GLTx8	23747

DJFLx8	23748
GNFLx8	23749

CFQx8	23750
EIQx8	23751
GKQx8	23752

ELLx8	23755
-------	-------

DJjx8	23754
-------	-------

CGHx8	23753
GLHx8	23756

Midget-Mill® Name	EDP Order Number
-------------------	------------------

CLA-Wx8	23780
ELA-Wx8	23781
GLA-Wx8	23782

CLA-EC-Wx8	23783
ELA-EC-Wx8	23784
GLA-EC-Wx8	23785

CCB-Wx8	23786
EEB-Wx8	23787
GBB-Wx8	23788

CLC-Wx8	23789
ELC-Wx8	23790
GLC-Wx8	23791

CJR-Wx8	23792
EJR-Wx8	23793
GLR-Wx8	23794

CJT-Wx8	23795
EJT-Wx8	23796
GLT-Wx8	23797

DJFL-Wx8	23798
GNFL-Wx8	23799

CFQ-Wx8	23800
EIQ-Wx8	23801
GKQ-Wx8	23802

ELL-Wx8	23805
---------	-------

DJJ-Wx8	23804
---------	-------

CGH-Wx8	23803
GLH-Wx8	23806



Phone: 989-777-5500 Fax: 989-777-0602

E-Mail: severancetool@sbcglobal.net

Severance Tool Industries Inc. • POB 1866 • Saginaw, MI 48605

Carbo-Mills™ & Ecarno-Mills™

3/16" Shank Diameter –

2" Overall Length

Carbo-Mills™ - tough durable carbide features the Severance Double-Cut flute design.

Ecarno-Mills™ - carbide with standard spiral flute design.



Shape "A"



Shape "B"



Shape "C"



Shape "L","H","J", and "M"



Shape "N"



Shape "Q"



Shape "R"



Shape "T"



Tapered End 90° Included



Tapered End 60° Included

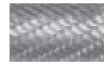

Carbide Carbo-Mill™



Carbide Ecarno-Mills®

Head Dia.	Flute Length	Nose Point, Flat, or Radius
-----------	--------------	-----------------------------

Carbo-Mill™ Name	EDP Order Number
------------------	------------------

Ecarno-Mill™ Name	EDP Order Number
-------------------	------------------

Cylindrical, Plain Nose, Shape "A"

1/8"	3/8"	-
3/16"	1/2"	-

6A4-W	22280
6A-W	22281

SA-82	21920
SA-81	21921

Cylindrical, End Cutting, Shape "A"

1/8"	3/8"	-
3/16"	1/2"	-

6A4-EC-W	22282
6A-EC-W	22283

SB-82	21922
SB-81	21923

Ball, Shape "B"

1/8"	3/32"	-
3/16"	11/64"	-

6B4-W	22284
6B-W	22285

SD-82	21924
SD-81	21925

Cylindrical, Ball Nose, Shape "C"

1/8"	3/8"	-
3/16"	1/2"	-

6C4-W	22286
6C-W	22287

SC-82	21926
SC-81	21927

Olive, Shape "Q"

3/16"	9/32"	-
3/16"	3/8"	-

-	-
6Q-W	22288

SE-81	21928
-	-

Tree, Radius Nose, Shape "R"

3/16"	1/2"	.048"
-------	------	-------

6R-W	22289
------	-------

SF-81	21929
-------	-------

Tree, Pointed Nose, Shape "T"

3/16"	1/2"	P
-------	------	---

6T-W	22290
------	-------

SG-81	21930
-------	-------

Cone, 7° Included, Shape "H"

3/16"	1/2"	.067"
-------	------	-------

6H-W	22293
------	-------

-	-
---	---

Cone, 10° Included, Shape "M"

3/16"	1/4"	.031"
3/16"	5/16"	.031"

6M4-W	22292
6M-W	22291

-	-
-	-

Cone, 12° Included, Shape "J"

3/16"	7/16"	F
3/16"	5/8"	.067"

6J-W	22295
-	-

-	-
SM-81	21932

Cone, 14° Included, Shape "L"

3/16"	3/8"	.054"
3/16"	7/16"	.031"

6L-W	22294
-	-

-	-
SL-81	21931

Flame, Shape "FL"

3/16"	1/4"	-
3/16"	5/16"	-

6GN-W	22296
-	-

-	-
SH-81	21933

Inverted Cone, Plain End, Shape "N"

3/16"	3/16"	-
-------	-------	---

6N-W	22297
------	-------

SN-81	21934
-------	-------

Inverted Cone, End Cutting, Shape "N"

3/16"	3/16"	-
-------	-------	---

6N-EC-W	22298
---------	-------

SN-82	21935
-------	-------

Tapered End, 60° Included Angle Double End

3/16"	5/32"	P
-------	-------	---

6Z-W-DE	20622
---------	-------

SJ-81	21937
-------	-------

Tapered End, 90° Included Angle Double End

3/16"	3/32"	P
-------	-------	---

6Y-W-DE	20682
---------	-------

SK-81	21936
-------	-------

Severance Tool Industries, Inc.
Manufactures Code 662018
Website: www.severancetool.com



Phone: 989-777-5500 Fax: 989-777-0602

E-Mail: severancetool@sbcglobal.net

Severance Tool Industries Inc. • POB 1866 • Saginaw, MI 48605

Carbo-Mills™ & Ecarno-Mills™

1/8" Shank Diameter –
1-1/2" Overall Length

Carbo-Mills™ - tough durable carbide features the Severance Double-Cut flute design.

Ecarno-Mills™ - carbide with standard spiral flute design.



Shape "A"



Shape "A"



Shape "B"



Shape "C"



Shape "C"

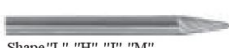

Shape "L", "H", "J", "M"



Shape "N",



Shape "Q",



Shape "R"



Shape "T"



Tapered End 90° Incl



Tapered End 60° Incl

* SB-41 (EDP #21773) is only available in a double ended style

Head Dia.	Flute Length	Nose Point, Flat, or Radius
1/16"	1/4"	-
3/32"	7/16"	-
3/32"	1/2"	-
1/8"	9/16"	-

Cylindrical, End Cutting, Shape "A"

Head Dia.	Flute Length	Nose Point, Flat, or Radius
1/16"	1/4"	-
3/32"	7/16"	-
3/32"	1/2"	-
1/8"	9/16"	-
1/8"	3/8"	-

Ball, Shape "B"

Head Dia.	Flute Length	Nose Point, Flat, or Radius
3/32"	5/64"	-
1/8"	3/32"	-

Cylindrical, Ball Nose, Shape "C"

Head Dia.	Flute Length	Nose Point, Flat, or Radius
3/32"	1/2"	-
3/32"	7/16"	-
1/8"	9/16"	-

Olive, Shape "Q"

Head Dia.	Flute Length	Nose Point, Flat, or Radius
1/8"	7/32"	-

Tree, Radius Nose, Shape "R"

Head Dia.	Flute Length	Nose Point, Flat, or Radius
1/8"	1/4"	.031"
1/8"	1/2"	.031"

Tree, Radius Nose, Shape "S"

Head Dia.	Flute Length	Nose Point, Flat, or Radius
1/8"	1/2"	.031"

Tree, Pointed Nose, Shape "T"

Head Dia.	Flute Length	Nose Point, Flat, or Radius
1/8"	1/4"	P
1/8"	3/8"	P
1/8"	1/2"	P

Cone, 7° Included, Shape "H"

Head Dia.	Flute Length	Nose Point, Flat, or Radius
1/8"	1/2"	.031"
1/8"	5/8"	.031"

Cone, 8° Included, Shape "L"

Head Dia.	Flute Length	Nose Point, Flat, or Radius
1/8"	3/8"	.039"
1/8"	1/2"	F

Cone, 10° Included, Shape "M"

Head Dia.	Flute Length	Nose Point, Flat, or Radius
3/32"	1/4"	.016"
1/8"	5/16"	.031"

Cone, 12° Included, Shape "J"

Head Dia.	Flute Length	Nose Point, Flat, or Radius
1/8"	11/32"	F
1/8"	7/16"	F

Cone, 14° Included, Shape "L"

Head Dia.	Flute Length	Nose Point, Flat, or Radius
1/8"	3/8"	.019"
1/8"	7/16"	.010"

Flame, Shape "FL"

Head Dia.	Flute Length	Nose Point, Flat, or Radius
1/8"	1/4"	-

Inverted Cone, Plain End, Shape "N"

Head Dia.	Flute Length	Nose Point, Flat, or Radius
3/32"	1/8"	-
1/8"	3/16"	-

Inverted Cone, End Cutting, Shape "N"

Head Dia.	Flute Length	Nose Point, Flat, or Radius
3/32"	1/8"	-
1/8"	3/16"	-

Tapered End, 60° Included Angle Double End

Head Dia.	Flute Length	Nose Point, Flat, or Radius
1/8"	"	P

Tapered End, 90° Included Angle Double End

Head Dia.	Flute Length	Nose Point, Flat, or Radius
1/8"	"	P

Carbo-Mill™ Name	Carbide Carbo-Mill™	
	EDP Order Number	
-	-	-
-	-	-
4A3-W	22230	-
4A-W	22231	-
-	-	-
4A3-EC-W	22232	-
4A-EC-W	22233	-
-	-	-
4B3-W	22234	-
4B-W	22235	-
4C3-W	22236	-
-	-	-
4C-W	22237	-
4Q-W	22238	-
-	-	-
-	-	-
4T-W	22240	-
4H-W	22243	-
-	-	-
-	-	-
4M3-W	22242	-
4M-W	22241	-
-	-	-
4J-W	22245	-
4L-W	22244	-
-	-	-
4GN-W	22246	-
-	-	-
4N-W	22247	-
-	-	-
4N-W-EC	22248	-
4Y-W-DE	22249	-
4Z-W-DE	22250	-

Ecarno-Mill™ Name	Carbide Ecarno-Mills®	
	EDP Order Number	
SA-41	21770	-
SA-42	21771	-
-	-	-
SA-43	21772	-
SB-42	21774	-
SB-43	21775	-
-	-	-
SB-44	21776	-
*SB-41	21773	-
SD-41	21777	-
SD-42	21778	-
-	-	-
SC-41	21779	-
SC-42	21780	-
SE-41	21781	-
SF-41	21783	-
SF-42	21782	-
-	-	-
SG-41	21786	-
SG-43	21785	-
SG-44	21784	-
-	-	-
SM-43	21787	-
SL-41	21791	-
SL-42	21790	-
-	-	-
-	-	-
SM-41	21789	-
-	-	-
SH-41	21792	-
SN-41	21794	-
SN-42	21793	-
SN-41	21794	-
SN-42	21793	-
SJ-41	21798	-
SK-41	21797	-



Phone: 989-777-5500 Fax: 989-777-0602

E-Mail: severancetool@sbcglobal.net

Severance Tool Industries Inc. • POB 1866 • Saginaw, MI 48605

Carbo-Mills™ &

Ecarno-Mills™

3/32" Shank Diameter –

2" Overall Length

Carbo-Mills™ - tough durable carbide features the Severance Double-Cut flute design.

Ecarno-Mills™ - carbide with standard spiral flute design.

Uses - Carbo-Mills™ cover a wide range of uses such as: removing gates, fins, and risers; breaking sharp corners and edges; machining carbon; finishing castings of any material; working fillets, radii, and grooves; deburring oil holes; blending welded and assembled parts; and removing weld beads. They are ideal for the production deburring and machining of parts made from materials that are abrasive or tough, or having hardness up to 60 "C" Rockwell. They are equally useful to maintenance men, and to tooling departments that produce dies, molds, and metal patterns.



Shape "A"



Shape "B"



Shape "C"



Shape "T"



Shape "N"



Shape "R"



Shape "H", "J", "L", and "M"



Tapered End 90° Included



Tapered End 60° Included

Head Dia.	Flute Length	Nose Point, Flat, or Radius
1/16"	1/4"	-
3/32"	3/8"	-

Cylindrical, Plain Nose, Shape "A"

Cylindrical, End Cutting, Shape "A"

Ball, Shape "B"

Cylindrical, Ball Nose, Shape "C"

Olive, Shape "Q"

Tree, Radius Nose, Shape "R"

Tree, Pointed Nose, Shape "T"

Cone, 7° Included, Shape "H"

Cone, 10° Included, Shape "M"

Cone, 12° Included, Shape "J"

Cone, 14° Included, Shape "L"

Flame, Shape "FL"

Inverted Cone, Plain End, Shape "N"

Inverted Cone, End Cutting, Shape "N"

Tapered End, 60° Included Angle Double End

Tapered End, 90° Included Angle Double End

Carbide Carbo-Mill™	
Carbo-Mill™ Name	EDP Order Number
3A2-W	22180
3A-W	22181

Carbide Ecarno-Mills®	
Ecarno-Mill™ Name	EDP Order Number
SA-61	21720
SA-63	21721

3A2-EC-W	22182
3A-EC-W	22183

SB-61	21723
SB-63	21724

3B2-W	22184
3B-W	22185

SD-61	21726
SD-63	21727

3C2-W	22186
3C-W	22187

SC-61	21728
SC-63	21729

3Q-W	22188
------	-------

SE-61	21730
-------	-------

3R-W	22189
------	-------

SF-61	21731
-------	-------

3T-W	22190
------	-------

SG-61	21732
-------	-------

3H-W	22193
------	-------

SM-63	21735
-------	-------

3M3-W	22192
3M-W	22191

SM-61	21734
SM-62	21733

3J-W	22195
------	-------

SL-61	21737
-------	-------

3L-W	22194
------	-------

SL-62	21736
-------	-------

3GN-W	22196
-------	-------

SH-61	21738
-------	-------

3N-W	22197
------	-------

SN-61	21739
-------	-------

3N-EC-W	22198
---------	-------

SN-62	21740
-------	-------

3Z-W-DE	20620
---------	-------

SJ-61	21741
-------	-------

3Y-W-DE	20680
---------	-------

SK-61	21742
-------	-------

Severance Tool Industries, Inc.
Manufactures Code 662018
Website: www.severancetool.com



Phone: 989-777-5500 Fax: 989-777-0602

E-Mail: severancetool@sbcglobal.net

Severance Tool Industries Inc. • POB 1866 • Saginaw, MI 48605

Specialty Midget Mills®

Junior Mills®



Junior Mills®

1/8" Shank Diameter – 1-5/8" Overall Length

These Popular tools are used for finishing the intricate patterns and parts, with surfaces difficult to reach with the large Midget Mills®. Junior Mills® are recommended for metal, wood, and plastic part finishing. Use them in place of grinding wheels or mounted points, they will cut faster, make real chips, and leave excellent finishes. Tools can be reground many times.

Junior Mills®



H.S.S.
Junior-Mill®
Single Cut
Chip Breakers



Carbide
Junior-Mill®
Single Cut

Head Dia.	Head Length	Nose Point, Flat or Radius	Tool Shape	H.S.S. Tool Name	EDP Order Number	Carbide Tool Name	EDP Order Number
3/16"	5/8"	-	Cylindrical, Plain End	JR-1	22721	JR-1-W	22821
3/16"	5/8"	-	Cylindrical, End Cutting	JR-1-EC	22724	JR-1-EC-W	22824
1/4"	1/2"	-	Cylindrical, Plain End	JR-2	22722	JR-2-W	22822
1/4"	1/2"	-	Cylindrical, End Cutting	JR-2-EC	22725	JR-2-EC-W	22825
1/8"	3/32"	-	Ball	JR-3	22726	JR-3-W	22826
1/4"	3/16"	-	Ball	JR-4	22727	JR-4-W	22828
3/16"	5/8"	-	Cylindrical, Ball Nose	JR-5	22730	JR-5-W	22830
3/16"	5/8"	P	Cone Forward Angle	JR-6	22741	JR-6-W	22841
3/16"	3/8"	-	Olive	JR-7	22732	JR-7-W	22832
1/8"	5/16"	.031"	Tree, Rounded Nose	JR-8	22734	JR-8-W	22834
3/16"	3/8"	.047"	Tree, Rounded Nose	JR-9	22735	JR-9-W	22835
3/16"	3/8"	-	Flame	JR-10	22738	JR-10-W	22838
3/8"	3/64"	-	Wheel, Cylindrical, Plain End	JR-11	22745	JR-11-W	22845
3/8"	3/64"	-	Wheel, Cylindrical, End Cutting	JR-11-EC	22746	JR-11-EC-W	22846
1/4"	1/4"	-	Inverted Cone, Plain End	JR-12	22743	JR-12-W	22843
1/4"	1/4"	-	Inverted Cone, End Cutting	JR-12-EC	22744	JR-12-EC-W	22844
3/16"	11/64"	-	Ball	JR-13	22728	JR-13-W	22827
1/8"	1/2"	-	Cylindrical, Plain End	JR-14	22720	JR-14-W	22820
1/8"	1/2"	-	Cylindrical, End Cutting	JR-14-EC	22723	JR-14-EC-W	22823
1/4"	1/2"	-	Cylindrical, Ball Nose	JR-15	22731	JR-15-W	22831
1/4"	1/2"	.031"	Cone Forward Angle	JR-16	22742	JR-16-W	22842
1/4"	1/2"	-	Olive	JR-17	22733	JR-17-W	22833
1/4"	1/2"	.063"	Tree, Rounded Nose	JR-18	22736	JR-18-W	22836
1/4"	1/2"	-	Flame	JR-19	22739	JR-19-W	22839
1/4"	1/16"	-	Wheel, Side Cutting, Double Angle	JR-20	22747	JR-20-W	22847
1/8"	11/64"	-	Flame	JR-21	22737	JR-21-W	22837
1/8"	13/32"	F	Cone Forward Angle	JR-22	22740	JR-22-W	22840
1/8"	1/2"	-	Cylindrical, Ball Nose	JR-23	22729	JR-23-W	22829



Phone: 989-777-5500 Fax: 989-777-0602

E-Mail: severancetool@sbcglobal.net

Severance Tool Industries Inc. • POB 1866 • Saginaw, MI 48605

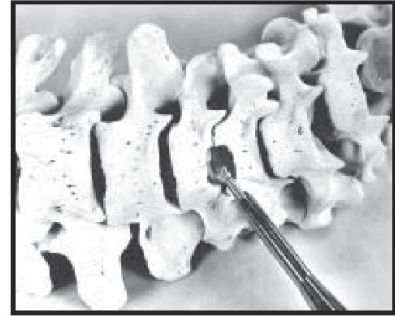

Lab Mills™ 3/32" Shank Diameter – 1-5/8" Overall Length

Lab Mills are made in nine shapes to accomplish almost any small milling operation. Each shape is offered in six different head diameters. Specify shape and diameter when ordering. Set No. 60, EDP# 29666 (pictured above) – 12 tools of selected shapes and sizes (3/32" and 3/16" diameters). Ideal for small and micro part milling, deburring, and finishing. Severance Lab Mills™ are manufactured of high quality High Speed Steel and will outlast several ordinary dental lab style burrs with the added advantage that Severance Lab Mills™ can be reground to as good as new many times. Lab Mills™ speed production for manufacturers of jewelry, diesel injectors, aircraft parts, die castings, dies, molds, electronic equipment, medical components, dental lab, missile and space components, exc.



**High Speed Steel
Lab Mills™**

Head Dia.	Flute Length	Nose Point, Flat, or Radius	Severance Tool Name	EDP Order Number
-----------	--------------	-----------------------------	---------------------	------------------

Ball

1/16"	.047"	-	LM1-062	22620
3/32"	.078"	-	LM1-093	22621
1/8"	.094"	-	LM1-125	22622
3/16"	.88"	-	LM1-187	22623
1/4"	.250"	-	LM1-250	22624
5/16"	.313"	-	LM1-312	22625

Cone, Pointed Nose, 25° C/L Angle

1/16"	.081"	-	LM2-062	22626
3/32"	.122"	-	LM2-093	22627
1/8"	.162"	-	LM2-125	22628
3/16"	.244"	-	LM2-187	22629
1/4"	.325"	-	LM2-250	22630
5/16"	.407"	-	LM2-312	22631

Wheel (Saw)

1/16"	.016"	-	LM3-062	22632
3/32"	.019"	-	LM3-093	22633
1/8"	.032"	-	LM3-125	22634
3/16"	.046"	-	LM3-187	22635
1/4"	.062"	-	LM3-250	22636
5/16"	.078"	-	LM3-312	22637

Bud Shape

1/16"	.087"	-	LM4-062	22638
3/32"	.130"	-	LM4-093	22639
1/8"	.178"	-	LM4-125	22640
3/16"	.261"	-	LM4-187	22641
1/4"	.348"	-	LM4-250	22642
5/16"	.435"	-	LM4-312	22643

Pear Shape

1/16"	.100"	-	LM5-062	22644
3/32"	.150"	-	LM5-093	22645
1/8"	.206"	-	LM5-125	22646

Head Dia.	Flute Length	Nose Point, Flat, or Radius	Severance Tool Name	EDP Order Number
-----------	--------------	-----------------------------	---------------------	------------------

Pear Shape CONTINUED

3/16"	.300"	-	LM5-187	22647
1/4"	.400"	-	LM5-250	22648
5/16"	.500"	-	LM5-312	22649

Tree, Rounded Nose

1/16"	.125"	.018"	LM6-062	22650
3/32"	.188"	.025"	LM6-093	22651
1/8"	.250"	.031"	LM6-125	22652
3/16"	.375"	.047"	LM6-187	22653
1/4"	.500"	.062"	LM6-250	22654
5/16"	.625"	.078"	LM6-312	22655

Inverted Cone

1/16"	.063"	-	LM7-062	22656
3/32"	.094"	-	LM7-093	22657
1/8"	.125"	-	LM7-125	22658
3/16"	.188"	-	LM7-187	22659
1/4"	.250"	-	LM7-250	22660
5/16"	.313"	-	LM7-312	22661

Flame

1/16"	.126"	-	LM8-062	22662
3/32"	.188"	-	LM8-093	22663
1/8"	.256"	-	LM8-125	22664
3/16"	.375"	-	LM8-187	22665
1/4"	.500"	-	LM8-250	22666
5/16"	.625"	-	LM8-312	22667

CYLINDER, Plain End

1/16"	.188"	-	LM9-062	22668
3/32"	.281"	-	LM9-093	22669
1/8"	.375"	-	LM9-125	22670
3/16"	.563"	-	LM9-187	22671
1/4"	.750"	-	LM9-250	22672
5/16"	.688"	-	LM9-312	22673

Severance Tool Industries, Inc.
Manufactures Code 662018
Website: www.severancetool.com



Phone: 989-777-5500 Fax: 989-777-0602

E-Mail: severancetool@sbcglobal.net

Severance Tool Industries Inc. • POB 1866 • Saginaw, MI 48605

**High Speed Steel
Extra Length Lab Mills™
Surgical Mills**

3/32" Shank Diameter – 2-1/2" Overall Length

Ideal for small and micro part deburring and finishing.
Also know as: "Surgical Mills", or "Jordan Day™ Mills".

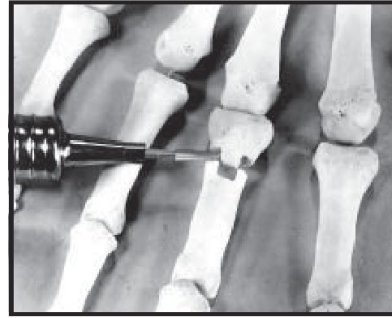

See Page 83 for our popular 12 piece Set No. 80 (EDP# 29680)

Head Diameter		Number of Teeth	Group Nomenclature	Severance Tool Name	EDP Order Number
Inches	MM				
.062"	1.6	6	Cutting Mills	JD-0	34310
.093"	2.4	6	Cutting Mills	JD-1	34311
.125"	3.2	6	Cutting Mills	JD-2	34312
.156"	4.0	6	Cutting Mills	JD-3	34313
.187"	4.7	6	Cutting Mills	JD-4	34314
.156"	4.0	8	Cutting Mills	JD-5	34315
.187"	4.7	8	Cutting Mills	JD-6	34316
.218"	5.5	8	Cutting Mills	JD-7	34317
.125"	3.2	8	Penetrating Mills	JD-8	34320
.039"	1.0	12	Polishing Mills	JD-9	34322
.059"	1.5	16	Polishing Mills	JD-10	34323
.078"	2.0	18	Polishing Mills	JD-11	34324
.090"	2.3	20	Polishing Mills	JD-12	34325
.118"	3.0	20	Polishing Mills	JD-13	34326
.156"	4.0	25	Polishing Mills	JD-14	34327
.250"	6.4	8	Cutting Mills	JD-15	34318
.281"	7.1	8	Cutting Mills	JD-16	34319
.078"	2.0	2	Penetrating Mills	JD-25	34321



**High Speed Steel
Ball Nose Deburring Cutters
1/4" Shank Diameter**

The **Plain** style is ideal for use in portable power tools for deburring holes as shown in the table. They produce approximately a 45° chamfer. When thrusting the tool into the hole at an angle, a large area of the mill is useful and not just a narrow circle.

The style **With Guide** is especially suited for deburring of oil holes in crankshafts because the guide on the end prevents the mill from slipping out of the hole and marring the bearing surface.

Plain

Head Dia.	Hole Size
3/16"	1/8"
1/4"	3/16"
3/8"	1/4"
1/2"	3/8"
5/8"	7/16"

With Guide

Severance Tool Name	EDP Order Number
BBC	00240
CBC	00241
ECC	00242
GDC	00243
IEC	00244

Severance Tool Name	EDP Order Number
BBC-G	00245
CBC-G	00246
ECC-G	00247
GDC-G	00248
IEC-G	00249



Phone: 989-777-5500 Fax: 989-777-0602
 E-Mail: severancetool@sbcglobal.net

Severance Tool Industries Inc. • POB 1866 • Saginaw, MI 48605

d-burrs™ for Plastic Part Deburring



Carbide d-burrs™ 1/4" Shank Diameter

For heavy, fast, stock removal of Aluminum see Sever-Cuts™ on pages 8-18.

d-burrs™ are designed for use on finishing plastic parts. Tools have the Severance EFHB cut for fine finishing of plastic and similar materials.

Head Dia.	Flute Length	Nose Flat or Radius	Shape	Tooth Style	Severance Tool Name	EDP Order Number
1/4"	5/8"	-	Cyl. Flat End	EFHC	CIA-W-HB	22160
1/2"	1"	-	Cyl. Flat End	EFHC	GLA-W-HB	22149
1/4"	1/4"	-	Ball	EFHC	CCB-W-HB	22161
1/4"	5/8"	-	Cyl. Ball Nose	EFHC	CIC-W-HB	22158
1/2"	1"	-	Cyl. Ball Nose	EFHC	GLC-W-HB	22162
1/4"	3/8"	F	Tapered, Radius Nose	EFHC	CEH-W-HB	22163
1/4"	1/2"	.068"	Tree, Radius Nose	EFHC	CGR-W-HB	22159
1/2"	1"	.125"	Tree, Radius Nose	EFHC	GLR-W-HB	22164

- JR-1-W-HB
- JR-2-W-HB
- JR-3-W-HB
- JR-4-W-HB
- JR-5-W-HB
- JR-6-W-HB
- JR-7-W-HB
- JR-8-W-HB
- JR-9-W-HB
- JR-10-W-HB
- JR-11-W-HB
- JR-12-W-HB
- JR-13-W-HB
- JR-14-W-HB
- JR-15-W-HB
- JR-16-W-HB
- JR-17-W-HB
- JR-18-W-HB
- JR-19-W-HB



Carbide Junior d-burrs™ 1/8" Shank Diameter - 1-5/8" Overall Length

Tools are supplied with a Herringbone Cut

Head Dia.	Head Length	Nose Point, Flat or Radius	Tool Shape	Severance Tool Name	EDP Order Number
3/16"	5/8"	-	Cylindrical, Plain End	JR-1-W-HB	22851
1/4"	1/2"	-	Cylindrical, Plain End	JR-2-W-HB	22852
1/8"	3/32"	-	Ball	JR-3-W-HB	22853
1/4"	3/16"	-	Ball	JR-4-W-HB	22855
3/16"	5/8"	-	Cylindrical, Ball Nose	JR-5-W-HB	22857
3/16"	5/8"	P	Cone Forward Angle	JR-6-W-HB	22868
3/16"	3/8"	-	Olive	JR-7-W-HB	22859
1/8"	5/16"	.031"	Tree, Rounded Nose	JR-8-W-HB	22861
3/16"	3/8"	.047"	Tree, Rounded Nose	JR-9-W-HB	22862
3/16"	3/8"	-	Flame	JR-10-W-HB	22865
3/8"	3/64"	-	Wheel, Cylindrical, Plain End	JR-11-W-HB	22871
1/4"	1/4"	-	Inverted Cone, Plain End	JR-12-W-HB	22870
3/16"	11/64"	-	Ball	JR-13-W-HB	22854
1/8"	1/2"	-	Cylindrical, Plain End	JR-14-W-HB	22850
1/4"	1/2"	-	Cylindrical, Ball Nose	JR-15-W-HB	22858
1/4"	1/2"	.031"	Cone Forward Angle	JR-16-W-HB	22869
1/4"	1/2"	-	Olive	JR-17-W-HB	22860
1/4"	1/2"	.063"	Tree, Rounded Nose	JR-18-W-HB	22863
1/4"	1/2"	-	Flame	JR-19-W-HB	22866
1/8"	11/64"	-	Flame	JR-21-W-HB	22864
1/8"	13/32"	F	Cone Forward Angle	JR-22-W-HB	22867
1/8"	1/2"	-	Cylindrical, Ball Nose	JR-23-W-HB	22856

Severance Tool Industries, Inc.
 Manufactures Code 662018
 Website: www.severancetool.com

Severance®

Phone: 989-777-5500 Fax: 989-777-0602

E-Mail: severancetool@sbcglobal.net

Severance Tool Industries Inc. • POB 1866 • Saginaw, MI 48605



Carbide

Bore Mills™

Severance Bore Mills™ are designed with a special fine double cut, to be used in place of mounted grinding wheels in jig grinding applications. Their convex shape provides rapid stock removal on cast iron, steel, nonferrous and many nonmetallic materials. Bore Mills™ are operated at the same speeds and feeds as grinding wheels and are capable of producing surface finishes in the 10 to 12 micro-inch range.

Head Dia.	Shank Dia.	Overall Length	Severance Tool Name	EDP Order Number	Head Dia.	Shank Dia.	Overall Length	Severance Tool Name	EDP Order Number
.047"	1/8"	1-1/2"	BM-3-W	00250	.250"	1/4"	2"	BM-16-W	00255
.078"	1/8"	1-1/2"	BM-5-W	00251	.312"	5/16"	2"	BM-20-W	00256
.109"	1/8"	1-1/2"	BM-7-W	00252	.375"	3/8"	2"	BM-24-W	00257
.125"	3/16"	2"	BM-8-W	00253	.500"	1/2"	2"	BM-32-W	00258
.172"	3/16"	2"	BM-11-W	00254					

NOTE: All Bore Mills™ are TiN coated at no extra Charge.



Carbide

Micro-Mills™

Micro-Mills™ are similar in application to the Bore Mills™, but are used for finishing in the 6 to 8 micro-inch range. Micro-Mills™ are designed with a fine cut with chip breakers. These mills are intended for applications where there is a light amount of stock removal required and work best on ferrous, non-work hardening materials. Micro-Mills™ should not be oscillated. Cut on the in-feed and burnish on the out-feed. Both Micro-Mills™ and Bore Mills™ will outlast grinding wheels, particularly on demanding operations such as chamfering and counter-boring.

Head Dia.	Shank Dia.	Overall Length	Severance Tool Name	EDP Order Number	Head Dia.	Shank Dia.	Overall Length	Severance Tool Name	EDP Order Number
.047"	1/8"	1-1/2"	MW-4	21120	.190"	3/16"	2"	MW-13	21134
.065"	1/8"	1-1/2"	MW-5	21130	.195"	1/4"	2"	MW-14	21125
.078"	1/8"	1-1/2"	MW-6	21121	.219"	1/4"	2"	MW-16	21126
.096"	1/8"	1-1/2"	MW-7	21131	.253"	1/4"	2"	MW-18	21135
.109"	1/8"	1-1/2"	MW-8	21122	.281"	1/4"	2"	MW-20	21127
.127"	1/8"	1-1/2"	MW-9	21132	.312"	1/4"	2"	MW-22	21136
.130"	3/16"	2"	MW-10	21123	.344"	1/4"	2"	MW-24	21128
.158"	3/16"	2"	MW-11	21133	.375"	1/4"	2"	MW-28	21137
.172"	3/16"	2"	MW-12	21124	.469"	1/4"	2"	MW-32	21129

NOTE: All Micro-Mills™ are TiN coated at no extra charge.



Phone: 989-777-5500 Fax: 989-777-0602
 E-Mail: severancetool@sbcglobal.net

Severance Tool Industries Inc. • POB 1866 • Saginaw, MI 48605



Carbide Die-Car Mills™
 Come with 1/4" shanks

Carbide Di-Car Mills™

Special herringbone or extra fine double cut tooth patterns are designed to replace the use of a grinding wheel. Intended for application where there is light stock removal and a very good finish is required. Works best on ferrous, non-work hardening materials. Can be used in either hand or machine applications.

Head Dia.	Flute Length	Nose Flat or Radius	Shape	Tooth Style	Severance Tool Name	EDP Order Number
1/4"	5/8"	-	Cyl. Flat End	Extra Fine Herringbone Cut	A-44-H-W	22150
1/2"	1"	-	Cyl. Flat End	Extra Fine Double Cut	A-48-D-W	22151
1/4"	1/4"	-	Ball	Extra Fine Herringbone Cut	B-44-H-W	22152
1/4"	5/8"	-	Cyl. Ball Nose	Extra Fine Double Cut	C-44-D-W	22153
1/2"	1"	-	Cyl. Ball Nose	Extra Fine Herringbone Cut	C-48-H-W	22154
1/4"	3/8"	F	Tapered, Radius Nose	Extra Fine Herringbone Cut	H-44-H-W	22155
1/4"	1/2"	.068"	Tree, Radius Nose	Extra Fine Double Cut	R-44-D-W	22156
1/2"	1"	.0125	Tree, Radius Nose	Extra Fine Herringbone Cut	R-48-H-W	22157

* 1/2" tools have 1/4" alloy steel, hardened shanks; all 1/4" tools are solid carbide.

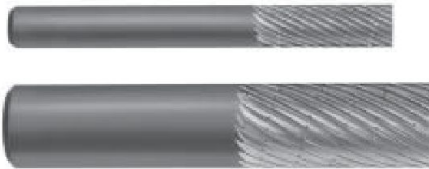

Die Mills

Die Mills are made with the shank and the cutting head of the same diameter. They are used extensively in template work, where the shank serves as a guide, and in other profiling operations. Die Mills may be reground many times for a long service life. When reground by Severance, a portion of the shank is reduced to match the new cutting diameter.

Carbide Die Mills

High Speed Steel Die Mills

Head Dia.	Shank Dia.	Flute Style
3/32"	3/32"	Standard Cut
1/8"	1/8"	Double Cut
1/8"	1/8"	Standard Cut
1/8"	1/8"	Standard Cut
5/32"	3/16"	Double Cut
5/32"	3/16"	Standard Cut
3/16"	3/16"	Double Cut
3/16"	3/16"	Standard Cut
1/4"	1/4"	Double Cut
1/4"	1/4"	Standard Cut
5/16"	5/16"	Double Cut
5/16"	5/16"	Standard Cut
3/8"	3/8"	Double Cut
3/8"	3/8"	Standard Cut
7/16"	7/16"	Double Cut
7/16"	7/16"	Standard Cut
1/2"	1/2"	Double Cut
1/2"	1/2"	Standard Cut

Flute Length	Overall Length	Severance Tool Name	EDP Order Number
-	-	-	-
1/2"	1-1/2"	4A-DIE-W	17260
1/2"	1-1/2"	AGA-DIE-W	17262
-	-	-	-
1/2"	2"	5A-DIE-W	17264
1/2"	2"	5GA-DIE-W	17266
3/4"	2"	6A-DIE-W	17268
3/4"	2"	BJA-DIE-W	17270
3/4"	2"	8A-DIE-W	17272
3/4"	2"	CJA-DIE-W	17274
13/16"	2"	10A-DIE-W	17276
3/4"	2"	DJA-DIE-W	17278
1"	2-1/2"	12A-DIE-W	17280
1"	2-1/2"	ELA-DIE-W	17282
1"	2-1/2"	14A-DIE-W	17284
1"	2-1/2"	FLA-DIE-W	17286
1"	2-1/2"	16A-DIE-W	17288
1"	2-1/2"	GLA-DIE-W	17290

Flute Length	Overall Length	Severance Tool Name	EDP Order Number
1/4"	1-5/8"	3/32CA-DIE	17310
-	-	-	-
1/2"	1-5/8"	AGA-DIE	17312
1-1/2"	3"	APA-DIE	17314
-	-	-	-
-	-	-	-
3/4"	2"	BJA-DIE	17316
-	-	-	-
3/4"	2-1/4"	CJA-DIE	17318
-	-	-	-
3/4"	2-1/4"	DJA-DIE	17320
-	-	-	-
7/8"	2-1/4"	EKA-DIE	17322
-	-	-	-
7/8"	2-1/4"	FLA-DIE	17324
-	-	-	-
1"	2-1/2"	GLA-DIE	17326

Severance Tool Industries, Inc.
 Manufactures Code 662018
 Website: www.severancetool.com

Severance®

Phone: 989-777-5500 Fax: 989-777-0602

E-Mail: severancetool@sbcglobal.net

Severance Tool Industries Inc. • POB 1866 • Saginaw, MI 48605

Tube Specialty Tools



Just as there are different reasons for finishing the cut ends of pipe or tubing, there are different tools and methods for doing the job.

1. Often, the only reason for finishing the cut end is to get rid of burrs caused by the cutting process. In that case, Tube End Deburring Cutters may make quick work of the task.
2. To facilitate assembly with other components, tube ends may be chamfered, using Severance Tube End Chamfering Mills.
3. The third method, forming, is used when appearance is important, as in an exposed tube end. Forming may also be recommended when the cut end must be square with the tube axis. Forming is the only method that finishes the end as well as the corners.

Tube End Deburring Cutters

Deburring cutters are identified as having smaller, more numerous cutting teeth than chamfering or forming tools. They can be operated over a wide speed range (slower is better in nonrigid setups) and take light cuts very quickly. Tube End Deburring Cutters are available from stock in sizes ranging from 1/8" to 2-1/4" OD. Each is adjustable for wall thickness. Standard cutters feature 30° and 45° centerline angles.

Inside, outside and tube end deburring cutters are available in carbide as well as HSS.

We also catalog the HR-Series radius deburring tools, which is usually sold with a handle for manual operation.

Tube End Chamfering Mills

Severance Tube End Chamfering Mills have cutting edges designed to provide a shearing action, yielding a smoothly machined surface. The standard tool produces a 30° angle on the tube ID and 45° on the OD. Other angles may be ordered as specials. This series of tools is offered in a range of sizes to accommodate pipe and tubing from 3/16" to 2-1/2" outside diameters. All models are adjustable for different wall thicknesses.

Severance also manufactures separate chamfering mills for inside and outside cutting. Inside Chamfering Mills are stocked in 1/2" to 1-1/2" sizes, with 30° or 45° centerline angles. Outside Chamfering Mills, for working diameters from 1/8" to 3" are also stocked in 30° or 45° models.

Tube End Forming Cutters

As the name implies, Severance Tube End Forming Cutters completely machine the cut ends of tubular products. They produce a smoothly rounded surface, which is both attractive and functional.

Because they are of solid construction, a specific tool is required for each different workpiece diameter and wall thickness. We also make many custom tube end forming cutters ... for nonstandard sizes and for machining profiles other than blended radii. Carbide is available on sizes of 3/8" OD and larger.

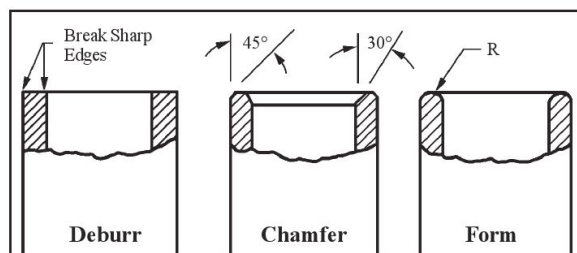



Phone: 989-777-5500 Fax: 989-777-0602
 E-Mail: severancetool@sbcglobal.net

Severance Tool Industries Inc. • POB 1866 • Saginaw, MI 48605



High Speed Steel Inside Deburring Cutters

Teeth as regularly furnished on these cutters are for quick light chamfering only. Stocked in 30° C/L and 45° C/L. The Inside Deburring Cutter is designed so that one tool can deburr many different hole diameters. The multi-flute design is self-piloting. For heavier countersinking, special arbors, or special angles, submit details to our Engineering Department. Holding of parts by hand is not recommended.

High Speed Steel 30° C/L (60° Included) Solid

Head Dia.	Nose Point or Flat Dia.	Overall Length	Severance Tool Name	EDP Order Number
1/4"	P	2-1/4"	ID-1/4-30	20770
5/16"	1/32"	2-1/4"	ID-5/16-30	20771
3/8"	P	2-1/4"	ID-3/8-30	20772
1/2"	9/64"	2-1/4"	IDS-1/2-30	20773
1/2"	P	2-1/4"	IDL-1/2-30	20774
5/8"	13/64"	2-1/4"	IDS-5/8-30	20775

High Speed Steel 45° C/L (90° Included) Solid

Head Dia.	Nose Point or Flat Dia.	Overall Length	Severance Tool Name	EDP Order Number
1/4"	P	2-1/4"	ID-1/4-45	20805
5/16"	1/16"	2-1/4"	ID-5/16-45	20806
3/8"	P	2-1/4"	ID-3/8-45	20807
1/2"	1/8"	2-1/4"	IDS-1/2-45	20808
1/2"	P	2-1/4"	IDL-1/2-45	20809
5/8"	1/8"	2-1/4"	IDS-5/8-45	20810

Tools above come with 1/4" shanks



Tools are furnished without shanks.
 See pages 78-80 for available shank styles and sizes.

High Speed Steel 30° C/L (60° Included) Threaded

Head Dia.	Nose Point or Flat Dia.	Overall Length	Thread Size	Severance Tool Name	EDP Order Number
5/8"	3/64"	7/8"	1/4"-28	ID-5/8-30	20776
3/4"	1/32"	1"	5/16"-24	ID-3/4-30	20777
7/8"	5/32"	1"	3/8"-24	ID-7/8-30	20778
1"	9/32"	1-1/8"	3/8"-24	IDS-1-30	20779
1"	1/8"	1-1/8"	3/8"-24	IDL-1-30	20780
1-1/8"	1/8"	1-1/8"	3/8"-24	ID-1-1/8-30	20781
1-1/4"	17/32"	1"	3/8"-24	IDS-1-1/4-30	20782
1-1/4"	3/32"	1-1/4"	3/8"-24	IDL-1-1/4-30	20783
1-1/2"	31/64"	1-1/8"	1/2"-20	IDS-1-1/2-30	20784
1-1/2"	13/64"	1-1/2"	1/2"-20	IDL-1-1/2-30	20785
1-3/4"	3/4"	1-1/4"	1/2"-20	IDS-1-3/4-30	20786
1-3/4"	5/16"	1-1/2"	1/2"-20	IDL-1-3/4-30	20787
2"	63/64"	1-1/4"	5/8"-18	IDS-2-30	20788
2"	27/32"	1-1/4"	5/8"-18	IDL-2-30	20789
2-1/4"	1-3/32"	1-3/8"	3/4"-16	IDS-2-1/4-30	20790
2-1/4"	33/64"	1-7/8"	3/4"-16	IDL-2-1/4-30	20791
2-1/2"	1-31/64"	1-1/4"	3/4"-16	IDS-2-1/2-30	20792
2-1/2"	29/32"	1-3/4"	3/4"-16	IDL-2-1/2-30	20793
3"	1-63/64"	1-1/4"	1"-14	ID-3-30	20794

High Speed Steel 45° C/L (90° Included) Threaded

Head Dia.	Nose Point or Flat Dia.	Overall Length	Thread Size	Severance Tool Name	EDP Order Number
5/8"	1/8"	11/16"	1/4"-28	ID-5/8-45	20811
3/4"	P	13/16"	5/16"-24	ID-3/4-45	20812
7/8"	5/32"	1"	3/8"-24	ID-7/8-45	20813
1"	1/4"	7/8"	3/8"-24	IDS-1-45	20814
1"	P	7/8"	3/8"-24	IDL-1-45	20815
1-1/4"	3/8"	3/4"	3/8"-24	IDS-1-1/4-45	20816
1-1/4"	P	1"	3/8"-24	IDL-1-1/4-45	20817
1-1/2"	1/2"	7/8"	1/2"-20	IDS-1-1/2-45	20818
1-1/2"	1/4"	1-1/16"	1/2"-20	IDL-1-1/2-45	20819
1-3/4"	5/8"	7/8"	1/2"-20	ID-1-3/4-45	20820
2"	1"	1"	5/8"-18	IDS-2-45	20821
2"	1/4"	1-1/2"	5/8"-18	IDL-2-45	20822
2-1/4"	1"	1"	5/8"-18	IDS-2-1/4-45	20823
2-1/4"	1/4"	1-3/8"	5/8"-18	IDL-2-1/4-45	20824
2-1/2"	3/4"	1-3/8"	3/4"-16	IDS-2-1/2-45	20825
2-1/2"	1/4"	1-5/8"	3/4"-16	IDL-2-1/2-45	20826
3"	3/4"	1-3/4"	1"-14	IDS-3-45	20827
3"	1/4"	1-7/8"	1"-14	IDL-3-45	20828

Severance Tool Industries, Inc.
 Manufactures Code 662018
 Website: www.severancetool.com



Phone: 989-777-5500 Fax: 989-777-0602

E-Mail: severancetool@sbcglobal.net

Severance Tool Industries Inc. • POB 1866 • Saginaw, MI 48605



Carbide Inside Deburring Cutters

All carbide Inside Deburring Cutters are designed with a pointed nose. Tools with a head diameter measuring 3/32" thru. 1/4" are made of solid carbide and are double ended. Inside Deburring Cutters with a head diameter measuring 5/16" thru. 2" have solid carbide heads brazed to hardened alloy precision ground shanks. Holding of parts by hand is not recommended.

Carbide

30° C/L (60° Included)

Head Dia.	Shank Dia.	Overall Length
3/32"	3/32"	1-1/2"
1/8"	1/8"	1-1/2"
3/16"	3/16"	2"
1/4"	1/4"	2"
5/16"	1/4"	2-1/4"
3/8"	1/4"	2-1/4"
1/2"	1/4"	2-1/4"
1/2"	3/8"	2-1/8"
5/8"	1/4"	2-3/8"
5/8"	3/8"	2-3/8"
3/4"	1/2"	2-11/16"
7/8"	1/2"	2-13/16"
1"	1/2"	2-13/16"

ANSI Number	Severance Tool Name	EDP Order Number
SJ-61	3Z-W-DE	20620
SJ-42	4Z-W-DE	22250
SJ-81	6Z-W-DE	20622
SJ-1	8Z-W-DE	22411
SJ-2	ID-5/16-30-W	20628
SJ-3	ID-3/8-30-W	20629
SJ-5	ID-1/2-30-W	20633
-	ID-1/2-30-W-3/8	20634
SJ-6	ID-5/8-30-W	20639
-	ID-5/8-30-W-3/8	20640
SJ-7	ID-3/4-30-W	20644
SJ-8	ID-7/8-30-W	20649
SJ-9	ID-1-30-W	20650

Carbide

45° C/L (90° Included)

ANSI Number	Severance Tool Name	EDP Order Number
SK-61	3Y-W-DE	20680
SK-42	4Y-W-DE	22249
SK-81	6Y-W-DE	20682
SK-1	8Y-W-DE	22412
SK-2	ID-5/16-45-W	20688
SK-3	ID-3/8-45-W	20689
SK-5	ID-1/2-45-W	20693
-	ID-1/2-45-W-3/8	20694
SK-6	ID-5/8-45-W	20699
-	ID-5/8-45-W-3/8	20700
SK-7	ID-3/4-45-W	20704
SK-8	ID-7/8-45-W	20709
SJK-9	ID-1-45-W	20710

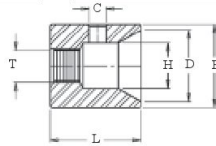

Tools are furnished without shanks.
See pages 78-80 for available shank styles and sizes.

High Speed Steel Outside Deburring Cutters

Outside Deburring Cutters are designed with shear-type cutting teeth to eliminate burrs on diameters of tubes and rods. One tool can handle various parts, may be reground, and can be provided in carbide.



NOTE: Tools O-0, O-1, O-2, O-3, O-20, O-21, and O-22 have the tooth pattern illustrated above.

Max. Cutting Dia.	"H" Recess Hole Dia.	"D" Mouth Dia.	"B" Body Dia.	"L" Body Length	"C" Coolant Hole	"T" I.D. Thread Size	C/L Inside Angle	Severance Tool Name	EDP Order Number
1/8"	1/16"	5/32"	1/2"	7/8"	-	1/4"-28	30°	O-0	25430
3/16"	5/32"	7/32"	1/2"	7/8"	-	1/4"-28	30°	O-1	25431
1/4"	13/64"	19/64"	1/2"	7/8"	-	1/4"-28	30°	O-2	25432
5/16"	.242"	23/64"	1/2"	7/8"	-	1/4"-28	30°	O-3	25433
3/8"	9/32"	7/16"	5/8"	7/8"	1/8"	1/4"-28	30°	O-4	25434
1/2"	.332"	9/16"	3/4"	1"	3/16"	3/8"-24	30°	O-5	25435
5/8"	7/16"	11/16"	7/8"	1"	3/16"	3/8"-24	30°	O-6	25436
3/4"	17/32"	53/64"	1"	1"	3/16"	3/8"-24	30°	O-7	25437
1"	45/64"	1-5/64"	1-1/4"	1-3/8"	1/4"	1/2"-20	30°	O-8	25438
1-1/4"	7/8"	1-21/64"	1-1/2"	1-3/8"	1/4"	1/2"-20	30°	O-9	25439
1-1/2"	1-3/64"	1-19/32"	1-3/4"	1-5/8"	1/4"	5/8"-18	30°	O-10	25440
2"	1-13/32"	2-7/64"	2-3/8"	1-7/8"	5/16"	3/4"-16	30°	O-11	25441
2-1/2"	1-3/4"	2-39/64"	2-7/8"	2-1/8"	5/16"	3/4"-16	30°	O-12	25442
3"	2-3/32"	3-1/8"	3-3/8"	2-1/2"	7/16"	3/4"-16	30°	O-13	25443
4"	2-13/16"	4-1/8"	4-3/8"	3"	7/16"	1"-14	30°	O-14	25444
1/8"	5/64"	3/16"	1/2"	7/8"	-	1/4"-28	45°	O-20	25460
3/16"	7/64"	7/32"	1/2"	7/8"	-	1/4"-28	45°	O-21	25461
1/4"	9/64"	23/64"	1/2"	7/8"	-	1/4"-28	45°	O-22	25462
3/8"	3/16"	7/16"	5/8"	7/8"	1/8"	1/4"-28	45°	O-23	25463
1/2"	1/4"	9/16"	3/4"	1"	3/16"	3/8"-24	45°	O-24	25464
3/4"	3/8"	13/16"	1"	1"	3/16"	3/8"-24	45°	O-25	25465
1"	1/2"	1-5/64"	1-1/4"	1-3/8"	1/4"	1/2"-20	45°	O-26	25466
1-1/2"	3/4"	1-19/32"	1-3/4"	1-1/2"	1/4"	5/8"-18	45°	O-27	25467
2"	15/16"	2-7/64"	2-3/8"	1-3/4"	5/16"	3/4"-16	45°	O-28	25468
3"	1-7/16"	3-1/8"	3-1/2"	2-1/4"	7/16"	3/4"-16	45°	O-29	25469
4"	1-15/16"	4-1/8"	4-3/8"	2-5/8"	7/16"	1"-14	45°	O-30	25470



Phone: 989-777-5500 Fax: 989-777-0602

E-Mail: severancetool@sbcglobal.net

Severance Tool Industries Inc. • POB 1866 • Saginaw, MI 48605

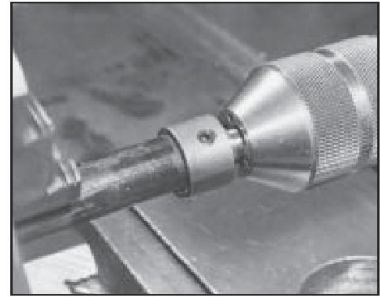

Caution: holding of tubing by hand is not recommended.

Tube End Deburring Cutters

The cutting teeth are designed to give a shearing cut. They'll curl the fine chips away from the cutter to avoid loading. The inside member produces a chamfer of 30° angle with C/L and the outside member 45°. The tube end deburring cutters, are intended for light deburring only, and will quickly deburr tubes of most any machinable material. They are available in high speed steel and carbide for the tougher and harder materials. The tooth arrangement on these cutters has been adopted to cover the widest possible range of most commonly encountered materials. Any special material found not to be responsive to our Tube End Deburring Cutters should be given special consideration by our engineers. Simple guides such as V-blocks correctly positioned are recommended. The Ring or outside member is adjustable for more or less relative chamfer on the outside edge, and is secured after adjustment by socket screws. Operating speeds range from 50 to 200 R.P.M. depending on the size of the cutter, material and work condition. For heavier deburring, see the Severance Tube End Chamfering Mills listed on pages 37-38. Holding of parts by hand is not recommended.

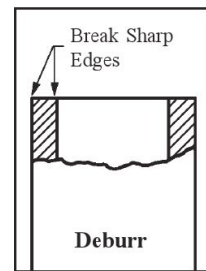

High Speed Steel

Tubing O.D. Size	Tubing I.D. Size	Hole Dia. OF Ring	Shank Dia.
1/8"	1/16"	.093"	1/4"
3/16"	1/8"	.156"	1/4"
1/4"	3/16"	.218"	1/4"
5/16"	1/4"	.281"	5/16"
3/8"	5/16"	.343"	3/8"
7/16"	3/8"	.406"	7/16"
1/2"	7/16"	.468"	1/2"
9/16"	1/2"	.531"	1/2"
5/8"	9/16"	.595"	1/2"
3/4"	5/8"	.685"	1/2"
7/8"	3/4"	.805"	1/2"
1"	7/8"	.930"	1/2"
1-1/8"	1"	1.063"	1/2"-20
1-1/4"	1-1/8"	1.180"	1/2"-20
1-3/8"	1-1/4"	1.313"	1/2"-20
1-1/2"	1-3/8"	1.430"	5/8"-18
1-3/4"	1-5/8"	1.680"	5/8"-18
2"	1-3/4"	1.930"	3/4"-16
2-1/4"	2"	2.180"	3/4"-16

Carbide

Severance Tool Name	EDP Order Number
A-Tube	35060
BA-Tube	35061
CB-Tube	35062
DC-Tube	35063
ED-Tube	35064
FE-Tube	35065
GF-Tube	35066
HG-Tube	35067
IH-Tube	35068
JI-Tube	35069
KJ-Tube	35070
LK-Tube	35071
ML-Tube	35072
NM-Tube	35073
ON-Tube	35074
PO-Tube	35075
RQ-Tube	35076
SR-Tube	35077
TS-Tube	35078

Severance Tool Name	EDP Order Number
A-Tube-W	35160
BA-Tube-W	35161
CB-Tube-W	35162
DC-Tube-W	35163
ED-Tube-W	35164
FE-Tube-W	35165
GF-Tube-W	35166
HG-Tube-W	35167
IH-Tube-W	35168
JI-Tube-W	35169
KJ-Tube-W	35170
LK-Tube-W	35171
-	-
-	-
-	-
-	-
-	-
-	-
-	-
-	-

High Speed Steel Tube End Deburring tools ML-Tube through TS-Tube require threaded shanks, priced separately. Tools furnished without shanks. See pages 78-80 for available shank styles and sizes.

Severance Tool Industries, Inc.
 Manufactures Code 662018
 Website: www.severancetool.com



Phone: 989-777-5500 Fax: 989-777-0602

E-Mail: severancetool@sbcglobal.net

Severance Tool Industries Inc. • POB 1866 • Saginaw, MI 48605



Inside Chamfer Mills

Severance Inside Chamfering Mills can be depended upon to produce smooth, burrless, chamfers on most machinable materials and are suitable for fairly heavy chamfering. For still heavier chamfering, consider Severance's Chatterless™ countersinks, on pages50-67. Holding of parts by hand is not recommended.

High Speed Steel
30° C/L (60° Included) Solid

Head Dia.	Nose Point or Flat Dia.	Overall Length	Severance Tool Name	EDP Order Number
1/4"	P	2-1/4"	IC-1/4-30	20470
5/16"	1/32"	2-1/4"	IC-5/16-30	20471
3/8"	P	2-1/4"	IC-3/8-30	20472
1/2"	9/64"	2-1/4"	ICS-1/2-30	20473
1/2"	P	2-1/4"	ICL-1/2-30	20474
5/8"	13/64"	2-1/4"	ICS-5/8-30	20475

High Speed Steel
45° C/L (90° Included) Solid

Head Dia.	Nose Point or Flat Dia.	Overall Length	Severance Tool Name	EDP Order Number
1/4"	P	2-1/4"	IC-1/4-45	20505
5/16"	1/16"	2-1/4"	IC-5/16-45	20506
3/8"	P	2-1/4"	IC-3/8-45	20507
1/2"	1/8"	2-1/4"	ICS-1/2-45	20508
1/2"	P	2-1/4"	ICL-1/2-45	20509
5/8"	1/8"	2-1/4"	ICS-5/8-45	20510

NOTE: All solid Inside Chamfering Mills have a 1/4" shank diameter.

Tools are furnished without shanks.
See pages 78-80 for available shank styles and sizes.



High Speed Steel
30° C/L (60° Included) Threaded

Head Dia.	Nose Point or Flat Dia.	Overall Length	Thread Size	Severance Tool Name	EDP Order Number
5/8"	3/64"	7/8"	1/4"-28	IC-5/8-30	20476
3/4"	1/32"	1"	5/16"-24	IC-3/4-30	20477
7/8"	5/32"	1"	3/8"-24	IC-7/8-30	20478
1"	9/32"	1-1/8"	3/8"-24	ICS-1-30	20479
1"	1/8"	1-1/8"	3/8"-24	ICL-1-30	20480
1-1/8"	1/8"	1-1/8"	3/8"-24	IC-1-1/8-30	20481
1-1/4"	17/32"	1"	3/8"-24	ICS-1-1/4-30	20482
1-1/4"	3/32"	1-1/4"	3/8"-24	ICL-1-1/4-30	20483
1-1/2"	31/64"	1-1/8"	1/2"-20	ICS-1-1/2-30	20484
1-1/2"	13/64"	1-1/2"	1/2"-20	ICL-1-1/2-30	20485
1-3/4"	3/4"	1-1/4"	1/2"-20	ICS-1-3/4-30	20486
1-3/4"	5/16"	1-1/2"	1/2"-20	ICL-1-3/4-30	20487
2"	63/64"	1-1/4"	5/8"-18	ICS-2-30	20488
2"	27/32"	1-1/4"	5/8"-18	ICL-2-30	20489
2-1/4"	1-3/32"	1-3/8"	3/4"-16	ICS-2-1/4-30	20490
2-1/4"	33/64"	1-7/8"	3/4"-16	ICL-2-1/4-30	20491
2-1/2"	1-31/64"	1-1/4"	3/4"-16	ICS-2-1/2-30	20492
2-1/2"	29/32"	1-3/4"	3/4"-16	ICL-2-1/2-30	20493
3"	1-63/64"	1-1/4"	1"-14	IC-3-30	20494

High Speed Steel
45° C/L (90° Included) Threaded

Head Dia.	Nose Point or Flat Dia.	Overall Length	Thread Size	Severance Tool Name	EDP Order Number
5/8"	1/8"	11/16"	1/4"-28	IC-5/8-45	20511
3/4"	P	13/16"	5/16"-24	IC-3/4-45	20512
7/8"	5/32"	1"	3/8"-24	IC-7/8-45	20513
1"	1/4"	7/8"	3/8"-24	ICS-1-45	20514
1"	P	7/8"	3/8"-24	ICL-1-45	20515
1-1/4"	3/8"	3/4"	3/8"-24	ICS-1-1/4-45	20516
1-1/4"	P	1"	3/8"-24	ICL-1-1/4-45	20517
1-1/2"	1/2"	7/8"	1/2"-20	ICS-1-1/2-45	20518
1-1/2"	1/4"	1-1/16"	1/2"-20	ICL-1-1/2-45	20519
1-3/4"	5/8"	7/8"	1/2"-20	IC-1-3/4-45	20520
2"	1"	1"	5/8"-18	ICS-2-45	20521
2"	1/4"	1-1/2"	5/8"-18	ICL-2-45	20522
2-1/4"	1"	1"	5/8"-18	ICS-2-1/4-45	20523
2-1/4"	1/4"	1-3/8"	5/8"-18	ICL-2-1/4-45	20524
2-1/2"	3/4"	1-3/8"	3/4"-16	ICS-2-1/2-45	20525
2-1/2"	1/4"	1-5/8"	3/4"-16	ICL-2-1/2-45	20526
3"	3/4"	1-3/4"	1"-14	ICS-3-45	20527
3"	1/4"	1-7/8"	1"-14	ICL-3-45	20528

Special Inside Chamfer Mills

Special diameters, angles, and configurations can be quoted on this style



REF. # 54443



Phone: 989-777-5500 Fax: 989-777-0602

E-Mail: severancetool@sbcglobal.net

Severance Tool Industries Inc. • POB 1866 • Saginaw, MI 48605

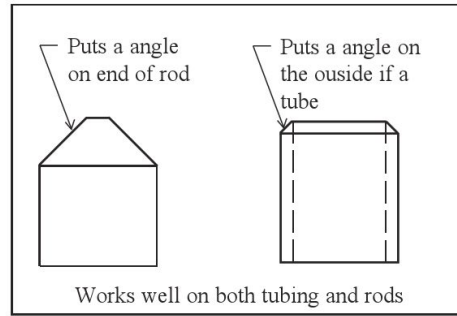
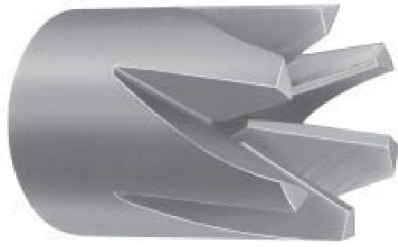

Outside Chamfering Mills

Outside Chamfering Mills are designed to economically chamfer a large variety of diameters on tubing, pipes, and rods. The Chatterless™ teeth produce a heavy chamfer, while one size will accommodate many size parts. The Outside Chamfering Mill is available in 60° and 90° included angles, and may be reground many times.

These Outside Chamfering Mills are most efficient when used in screw machines, lathes, drill presses, or other chucking machines, or with work holding devices, although where requirements are not too exacting, may be used in a portable power tool on some materials. Chatterless™ teeth provide amazing ease and speed of operation. It is recommended that guides such as V-blocks be positioned to facilitate quick positioning of the work.

High Speed Steel 30° C/L (60° Included)

Max. Cutting Dia.	I.D. Thread Size	Recess Hole Dia.	Mouth Dia.	Body Dia.	Body Length	Severance Tool Name	EDP Order Number
1/8"	5/16"-24	1/32"	3/16"	1/2"	1"	OC-1/8-30°	25230
1/4"	5/16"-24	3/64"	5/16"	1/2"	1"	OC-1/4-30°	25231
1/2"	3/8"-24	1/8"	5/8"	7/8"	1-5/16"	OC-1/2-30°	25232
3/4"	1/2"-20	1/4"	7/8"	1-1/8"	1-3/4"	OC-3/4-30°	25233
1"	3/4"-16	1/4"	1-1/8"	1-1/2"	2"	OC-1-30°	25234
1-3/4"	1"-14	1/2"	1-7/8"	2-1/4"	2-15/16"	OC-1-3/4-30°	25235
2"	1"-14	7/8"	2-1/8"	2-1/2"	3"	OC-2-30°	25236
3"	1-1/4"-12	1"	3-1/4"	3-3/4"	3-3/4"	OC-3-30°	25237

High Speed Steel 45° C/L (90° Included)

Max. Cutting Dia.	I.D. Thread Size	Recess Hole Dia.	Mouth Dia.	Body Dia.	Body Length	Severance Tool Name	EDP Order Number
1/8"	5/16"-24	1/32"	3/16"	1/2"	1"	OC-1/8-45°	25250
1/4"	5/16"-24	3/64"	5/16"	1/2"	1"	OC-1/4-45°	25251
1/2"	3/8"-24	1/8"	5/8"	7/8"	1-5/16"	OC-1/2-45°	25252
3/4"	1/2"-20	3/16"	7/8"	1-1/8"	1-5/16"	OC-3/4-45°	25253
1"	3/4"-16	1/4"	1-1/8"	1-1/2"	1-3/4"	OC-1-45°	25254
1-1/2"	3/4"-16	3/8"	1-5/8"	2"	1-7/8"	OC-1-1/2-45°	25255
2"	1"-14	7/8"	2-1/8"	2-1/2"	2-1/2"	OC-2-45°	25256
3"	1-1/4"-12	1"	3-1/4"	3-3/4"	2-7/8"	OC-3-45°	25257

See Page 45 for Rod End Forming Cutters to put a radius on the end of a rod

Tools are furnished without shanks. See pages 78-80 for available shank styles and sizes.

Severance Tool Industries, Inc.
Manufactures Code 662018
Website: www.severancetool.com



Phone: 989-777-5500 Fax: 989-777-0602

E-Mail: severancetool@sbcglobal.net

Severance Tool Industries Inc. • POB 1866 • Saginaw, MI 48605

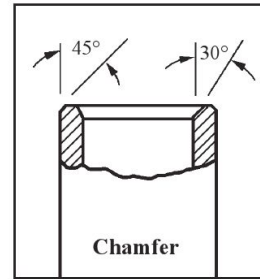

Caution: holding of tubing by hand is not recommended.

Tube End Chamfering Mills

The Chatterless™ design of the Tube End Chamfering Mills have cutting edges designed to provide a shearing action, yielding a smoothly machined surface. The standard tool produces a 30° angle on the tube inside diameter and 45° on the outside diameter. Other angles may be ordered as specials. This series of tools is offered in a range of sizes to accommodate pipe and tubing from 3/16" to 2-1/2" outside diameters. All models are adjustable for different wall thicknesses. The cutting teeth are developed as to preclude chatter and provide ample chip room for every operating condition. Moderate speeds of about 100 R.P.M. for 1-inch steel tubing to about 200 R.P.M. for 1/2-inch tubing are recommended for these cutters. It is advisable to start at a slower speed on any given material or size and increase until best results are obtained.

High Speed Steel

30° C/L inside diameter & 45° C/L outside diameter.

Std Pipe Size	Std. Tubing O.D. Size	Wall Thickness		Plug Dia.	Shank Dia.	Shank Length	Severance Tool Name	EDP Order Number
		Min.	Max.					
1/8"	3/16"	.022"	.045"	.152"	1/4"	7/8"	T-6	34960
	1/4"	.022"	.065"	.228"	1/4"	1"	T-8	34961
	5/16"	.022"	.095"	.290"	1/4"	1"	T-10	34962
	3/8"	.022"	.095"	.353"	3/8"	1"	T-12	34963
	7/16"	.028"	.095"	.409"	3/8"	1"	T-14	34964
1/4"	1/2"	.028"	.095"	.472"	3/8"	1"	T-16	34965
	9/16"	.028"	.120"	.534"	1/2"	1"	T-18	34966
3/8"	5/8"	.028"	.120"	.597"	1/2"	1"	T-20	34967
1/2"	3/4"	.028"	.120"	.722"	1/2"	1"	T-24	34968
	7/8"	.022"	.156"	.847"	1/2"	1"	T-28	34969
3/4"	1"	.035"	.156"	.965"	1/2"	1-5/16"	T-32	34970
	1-1/8"	.035"	.187"	1.090"	1/2"-20	-	T-36	34971
	1-1/4"	.035"	.187"	1.215"	5/8"-18	-	T-40	34972
	1-5/16"	.035"	.187"	1.280"	5/8"-18	-	T-42	34973
	1-3/8"	.035"	.187"	1.340"	5/8"-18	-	T-44	34974
1-1/2"	1-1/2"	.035"	.250"	1.465"	3/4"-16	-	T-48	34975
1-1/4"	1-5/8"	.035"	.250"	1.590"	3/4"-16	-	T-52	34976
1-1/2"	1-3/4"	.035"	.250"	1.715"	3/4"-16	-	T-56	34977
	1-7/8"	.035"	.250"	1.840"	3/4"-16	-	T-60	34978
2"	2"	.035"	.312"	1.965"	1"-14	-	T-64	34979
	2-1/4"	.058"	.312"	2.195"	1"-14	-	T-72	34980
	2-3/8"	.065"	.375"	2.310"	1"-14	-	T-76	34981
	2-1/2"	.065"	.375"	2.435"	1"-14	-	T-80	34982

High Speed Steel Tube End Chamfering tools T-36 through T-80 require threaded shanks, priced separately. Tools furnished without shanks. See pages 78-80 for available shank styles and sizes.



Phone: 989-777-5500 Fax: 989-777-0602

E-Mail: severancetool@sbcglobal.net

Severance Tool Industries Inc. • POB 1866 • Saginaw, MI 48605

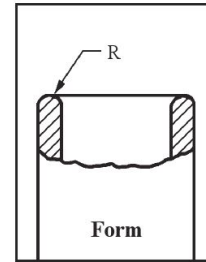

Caution: holding of tubing by hand is not recommended.

Tube End Forming Cutters

These cutters are used to produce a smooth, round lip on all types of tubing, including steel, copper, aluminum, plastic and other materials. They are not recommended for tubing with irregular wall thickness or for interrupted cutting. Larger sizes (A-6 x .025 and up) can be supplied in carbide. Special cutting shapes can also be provided. Speeds of about 50 to 350 RPM are suggested for these cutters. It is advisable to start at a slower speed on any given material or size, and increase until best results are obtained. Order by tool number plus wall thickness of tubing: A-6-.035, A-16-.065, etc. If possible, provide a sample of your tubing when ordering, or, at least, give material specification.

High Speed Steel

Tubing Size	Wall Thickness		Shank Dia.	Head Dia.	Overall Length	Shank Length	Severance Tool Name	EDP Order Number
	Gauge	Inch						
1/8"	31	.010"	1/4"	1/4"	2-1/4"	2"	A-2-010	35460
1/8"	27	.016"	1/4"	1/4"	2-1/4"	2"	A-2-016	35461
1/8"	25	.020"	1/4"	1/4"	2-1/4"	2"	A-2-020	35462
1/8"	22	.028"	1/4"	1/4"	2-1/4"	2"	A-2-028	35463
1/8"	21	.032"	1/4"	1/4"	2-1/4"	2"	A-2-032	35464
1/8"	21	.035"	1/4"	1/4"	2-1/4"	2"	A-2-035	35465
3/16"	25	.020"	3/8"	1/2"	1-9/16"	1"	A-3-020	35466
3/16"	22	.028"	3/8"	1/2"	1-9/16"	1"	A-3-028	35467
3/16"	21	.032"	3/8"	1/2"	1-9/16"	1"	A-3-032	35468
3/16"	20	.035"	3/8"	1/2"	1-9/16"	1"	A-3-035	35469
1/4"	25	.020"	3/8"	1/2"	1-9/16"	1"	A-4-020	35470
1/4"	22	.028"	3/8"	1/2"	1-9/16"	1"	A-4-028	35471
1/4"	21	.032"	3/8"	1/2"	1-9/16"	1"	A-4-032	35472
1/4"	20	.035"	3/8"	1/2"	1-9/16"	1"	A-4-035	35473
1/4"	18	.049"	3/8"	1/2"	1-9/16"	1"	A-4-049	35474
1/4"	16	.065"	3/8"	1/2"	1-9/16"	1"	A-4-065	35475
5/16"	25	.020"	3/8"	9/16"	1-9/16"	1"	A-5-020	35476
5/16"	22	.028"	3/8"	9/16"	1-9/16"	1"	A-5-028	35477
5/16"	21	.032"	3/8"	9/16"	1-9/16"	1"	A-5-032	35478
5/16"	20	.035"	3/8"	9/16"	1-9/16"	1"	A-5-035	35479
5/16"	18	.049"	3/8"	9/16"	1-9/16"	1"	A-5-049	35480
5/16"	17	.058"	3/8"	9/16"	1-9/16"	1"	A-5-058	35481
5/16"	16	.065"	3/8"	9/16"	1-9/16"	1"	A-5-065	35482
3/8"	25	.020"	1/2"	3/4"	1-9/16"	1"	A-6-020	35483
3/8"	22	.028"	1/2"	3/4"	1-9/16"	1"	A-6-028	35484
3/8"	21	.032"	1/2"	3/4"	1-9/16"	1"	A-6-032	35485
3/8"	20	.035"	1/2"	3/4"	1-9/16"	1"	A-6-035	35486
3/8"	18	.049"	1/2"	3/4"	1-9/16"	1"	A-6-049	35487
3/8"	17	.058"	1/2"	3/4"	1-9/16"	1"	A-6-058	35488
3/8"	16	.065"	1/2"	3/4"	1-9/16"	1"	A-6-065	35489
7/16"	25	.020"	1/2"	3/4"	1-9/16"	1"	A-7-020	35490
7/16"	22	.028"	1/2"	3/4"	1-9/16"	1"	A-7-028	35491

Severance Tool Industries, Inc.
 Manufactures Code 662018
 Website: www.severancetool.com



Phone: 989-777-5500 Fax: 989-777-0602

E-Mail: severancetool@sbcglobal.net

Severance Tool Industries Inc. • POB 1866 • Saginaw, MI 48605

Tube end forming cutters continued...

High Speed Steel

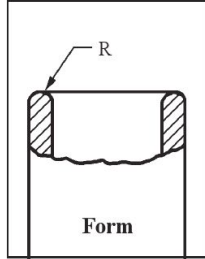

Holding of tubing by hand is not recommended.



Other Sizes, Shapes, and Form available as a special. Metric sizes also available as a special.

Tube End Forming Cutters for tubing 7/8" and larger, require threaded shanks. See pages 78-80 for available shank styles and sizes.

Tubing Size	Wall Thickness		Shank Dia.	Head Dia.	Overall Length	Shank Length	Severance Tool Name	EDP Order Number
	Gauge	Inch						
7/16"	21	.032"	1/2"	3/4"	1-9/16"	1"	A-7-032	35492
7/16"	20	.035"	1/2"	3/4"	1-9/16"	1"	A-7-035	35493
7/16"	18	.049"	1/2"	3/4"	1-9/16"	1"	A-7-049	35494
7/16"	16	.065"	1/2"	3/4"	1-9/16"	1"	A-7-065	35495
1/2"	25	.020"	1/2"	3/4"	1-9/16"	1"	A-8-020	35496
1/2"	22	.028"	1/2"	3/4"	1-9/16"	1"	A-8-028	35497
1/2"	21	.032"	1/2"	3/4"	1-9/16"	1"	A-8-032	35498
1/2"	20	.035"	1/2"	3/4"	1-9/16"	1"	A-8-035	35499
1/2"	18	.049"	1/2"	3/4"	1-9/16"	1"	A-8-049	35500
1/2"	17	.058"	1/2"	3/4"	1-9/16"	1"	A-8-058	35501
1/2"	16	.065"	1/2"	3/4"	1-9/16"	1"	A-8-065	35502
1/2"	14	.083"	1/2"	3/4"	1-9/16"	1"	A-8-083	35503
9/16"	22	.028"	1/2"	7/8"	1-5/8"	1"	A-9-028	35504
9/16"	20	.035"	1/2"	7/8"	1-5/8"	1"	A-9-035	35505
9/16"	18	.049"	1/2"	7/8"	1-5/8"	1"	A-9-049	35506
9/16"	16	.065"	1/2"	7/8"	1-5/8"	1"	A-9-065	35507
9/16"	13	.095"	1/2"	7/8"	1-5/8"	1"	A-9-095	35508
5/8"	22	.028"	1/2"	7/8"	1-5/8"	1"	A-10-028	35509
5/8"	21	.032"	1/2"	7/8"	1-5/8"	1"	A-10-032	35510
5/8"	20	.035"	1/2"	7/8"	1-5/8"	1"	A-10-035	35511
5/8"	18	.049"	1/2"	7/8"	1-5/8"	1"	A-10-049	35512
5/8"	17	.058"	1/2"	7/8"	1-5/8"	1"	A-10-058	35513
5/8"	16	.065"	1/2"	7/8"	1-5/8"	1"	A-10-065	35514
5/8"	14	.083"	1/2"	7/8"	1-5/8"	1"	A-10-083	35515
5/8"	13	.095"	1/2"	7/8"	1-5/8"	1"	A-10-095	35516
3/4"	22	.028"	1/2"	1"	1-5/8"	1"	A-12-028	35517
3/4"	21	.032"	1/2"	1"	1-5/8"	1"	A-12-032	35518
3/4"	20	.035"	1/2"	1"	1-5/8"	1"	A-12-035	35519
3/4"	18	.049"	1/2"	1"	1-5/8"	1"	A-12-049	35520
3/4"	17	.058"	1/2"	1"	1-5/8"	1"	A-12-058	35521
3/4"	16	.065"	1/2"	1"	1-5/8"	1"	A-12-065	35522
3/4"	14	.083"	1/2"	1"	1-5/8"	1"	A-12-083	35523
3/4"	13	.095"	1/2"	1"	1-5/8"	1"	A-12-095	35524
3/4"	11	.120"	1/2"	1"	1-5/8"	1"	A-12-120	35525
7/8"	22	.028"	1/2"-20	1-1/4"	1-1/8"	-	A-14-028	35526
7/8"	21	.032"	1/2"-20	1-1/4"	1-1/8"	-	A-14-032	35527
7/8"	20	.035"	1/2"-20	1-1/4"	1-1/8"	-	A-14-035	35528
7/8"	18	.049"	1/2"-20	1-1/4"	1-1/8"	-	A-14-049	35529
7/8"	17	.058"	1/2"-20	1-1/4"	1-1/8"	-	A-14-058	35530
7/8"	16	.065"	1/2"-20	1-1/4"	1-1/8"	-	A-14-065	35531
7/8"	14	.083"	1/2"-20	1-1/4"	1-1/8"	-	A-14-083	35532
7/8"	13	.095"	1/2"-20	1-1/4"	1-1/8"	-	A-14-095	35533
1"	22	.028"	1/2"-20	1-3/8"	1-1/8"	-	A-16-028	35534
1"	20	.035"	1/2"-20	1-3/8"	1-1/8"	-	A-16-035	35535
1"	18	.049"	1/2"-20	1-3/8"	1-1/8"	-	A-16-049	35536
1"	17	.058"	1/2"-20	1-3/8"	1-1/8"	-	A-16-058	35537
1"	16	.065"	1/2"-20	1-3/8"	1-1/8"	-	A-16-065	35538
1"	14	.083"	1/2"-20	1-3/8"	1-1/8"	-	A-16-083	35539
1"	13	.095"	1/2"-20	1-3/8"	1-1/8"	-	A-16-095	35540
1"	11	.120"	1/2"-20	1-3/8"	1-1/8"	-	A-16-120	35541
1-1/8"	22	.028"	1/2"-20	1-1/2"	1-1/8"	-	A-18-028	35542
1-1/8"	20	.035"	1/2"-20	1-1/2"	1-1/8"	-	A-18-035	35543
1-1/8"	18	.049"	1/2"-20	1-1/2"	1-1/8"	-	A-18-049	35544
1-1/8"	17	.058"	1/2"-20	1-1/2"	1-1/8"	-	A-18-058	35545
1-1/8"	16	.065"	1/2"-20	1-1/2"	1-1/8"	-	A-18-065	35546
1-1/4"	20	.035"	1/2"-20	1-1/2"	1-1/8"	-	A-20-035	35547
1-1/4"	18	.049"	1/2"-20	1-1/2"	1-1/8"	-	A-20-049	35548
1-1/4"	16	.065"	1/2"-20	1-1/2"	1-1/8"	-	A-20-065	35549
1-1/4"	14	.083"	1/2"-20	1-1/2"	1-1/8"	-	A-20-083	35550



Phone: 989-777-5500 Fax: 989-777-0602

E-Mail: severancetool@sbcglobal.net

Severance Tool Industries Inc. • POB 1866 • Saginaw, MI 48605

High Speed Steel Tube End Forming Cutters (continued)



Tubing Size	Wall Thickness		Shank Dia.	Head Dia.	Overall Length	Shank Length	Severance Tool Name	EDP Order Number
	GAUGE	INCH						
1-1/4"	11	.120	1/2"-20	1-1/2"	1-1/8"	-	A-20-120	35551
1-3/8"	20	.035	1/2"-20	1-5/8"	1-1/8"	-	A-22-035	35552
1-3/8"	18	.049	1/2"-20	1-5/8"	1-1/8"	-	A-22-049	35553
1-1/2"	18	.049	5/8"-18	2"	1-1/4"	-	A-24-049	35554
1-1/2"	17	.058	5/8"-18	2"	1-1/4"	-	A-24-058	35555
1-1/2"	16	.065	5/8"-18	2"	1-1/4"	-	A-24-065	35556
1-1/2"	14	.083	5/8"-18	2"	1-1/4"	-	A-24-083	35557
1-1/2"	13	.095	5/8"-18	2"	1-1/4"	-	A-24-095	35558
1-5/8"	16	.065	5/8"-18	2"	1-1/4"	-	A-26-065	35559

The above Tube End Forming Cutters require threaded shanks. See pages 78-80 for available shank styles and sizes.



EMT Tube End Forming Cutters

EMT for electrical conduit, standard thin wall type

Holding of tubing by hand is not recommended.

High Speed Steel



Tube O.D. Size	O.D.	I.D.	Wall Thickness	Shank Dia.	Shank Dia.	Severance Tool Name	EDP Order Number
3/8"	0.577	0.493	0.042	7/16"	1"	A-3/8-EMT	35579
1/2"	0.706	0.622	0.042	1/2"	1"	A-1/2-EMT	35580
3/4"	0.922	0.824	0.049	1/2"-20	-	A-3/4-EMT	35581
1"	1.163	1.049	0.057	1/2"-20	-	A-1-EMT	35582
1-1/4"	1.51	1.38	0.065	1/2"-20	-	A-1-1/4-EMT	35583
1-1/2"	1.74	1.61	0.065	5/8"-18	-	A-1-1/2-EMT	35584
2"	2.197	2.067	0.065	3/4" -16	-	A-2-EMT	35585

Tube End Forming Cutters for electrical conduit sizes 3/4" and larger require threaded shanks. See pages 78-80 for available shank styles and sizes.



Tube Hole Deburring Cutters

Inside Tube - Place cutter head inside hole, bring back against inner wall edge; follow around inner contour of hole letting the shank act as a guide.

Outside Tube - Place cutter in hole at right angle to tubing length. Geometrically (for any size hole) the diameter of the tool and the outside diameter of the tubing should equal.

High Speed Steel
Inside Style

Cutting Dia.	Neck Dia.	Shank Dia.	Severance Tool Name	EDP Order Number
7/32"	.109"	1/4"	7/32-IAD	35660
1/4"	.125"	1/4"	1/4-IAD	35661
5/16"	.187"	1/4"	5/16-IAD	35662
3/8"	.187"	1/4"	3/8-IAD	35663
7/16"	.250"	1/4"	7/16-IAD	35664
1/2"	.250"	1/4"	1/2-IAD	35665

High Speed Steel
Outside Style

Cutting Dia.	Cutting Length	Shank Dia.	Severance Tool Name	EDP Order Number
5/16"	1"	1/4"	DLA-LHS	35666
3/8"	1"	1/4"	ELA-LHS	35667
1/2"	1/2"	1/4"	GGA-LHS	35668
3/8"	1"	1/4"	ILA-LHS	35669
3/4"	3/4"	1/4"	JJA-LHS	35670
1"	1"	1/4"	LLA-LHS	35671

Severance® Tool Industries, Inc.
Manufactures Code 662018
Website: www.severancetool.com



Phone: 989-777-5500 Fax: 989-777-0602

E-Mail: severancetool@sbcglobal.net

Severance Tool Industries Inc. • POB 1866 • Saginaw, MI 48605

Specialty Tools

Whirly-Gig® Handle

The Severance Whirly-Gig® Handle is designed for fast efficient part deburring. A wide range of standard Severance deburring tools can be quickly interchanged for performing and finishing a variety of hand deburring operations.

How does the Severance Whirly-Gig® Handle work?



Severance has a wide variety of deburring tools to fit the Whirly-Gig® Handle

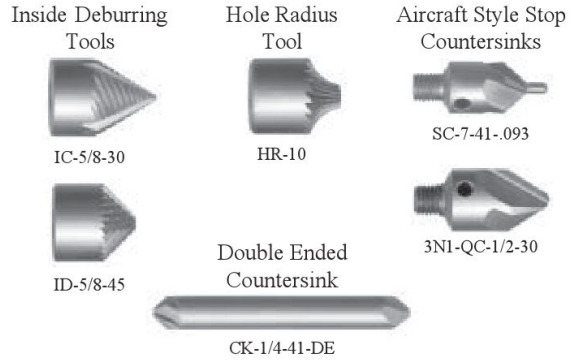

Tools	EDP#
Whirly-Gig® Handle	34266
Whirly-Gig® Extension	34267
Whirly-Gig® Holder-1/4	34273
Whirly-Gig® Set #344	34268
Whirly-Gig® Set #345	34271
Whirly-Gig® Set #346	34272

Whirly-Gig® Handle Accessories

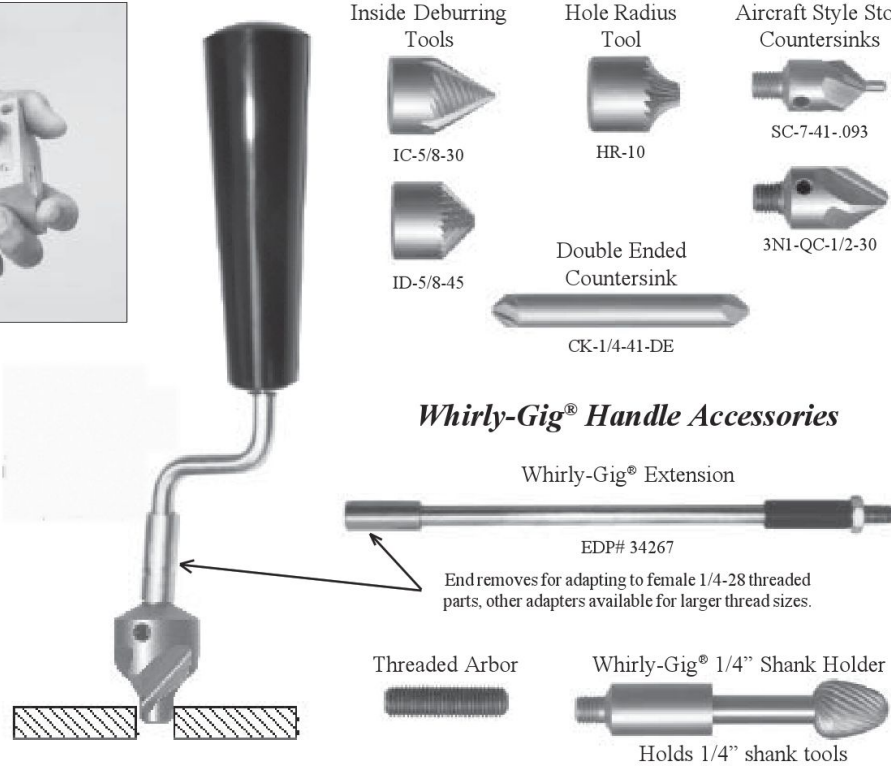

Whirly-Gig® Sets		
Whirly-Gig® Set #344 EDP# 34268 1 Whirly-Gig® Handle 1 Whirly-Gig® Extension 1 ID-5/8-30 1 ID-5/8-45 1 SC-7-41-.093 1 SC-7-45-.093 1 HR-10 1 Threaded Arbor	Whirly-Gig® Set #345 EDP# 34271 1 Whirly-Gig® Handle 1 Whirly-Gig® Holder-1/4 1 CK-1/4-45-DE 1 3N1-QC-1/2-45 1 Hex Wrench	Whirly-Gig® Set #346 EDP# 34272 1 Whirly-Gig® Handle 1 Whirly-Gig® Holder-1/4 1 CK-1/4-45-DE 1 CK-1/4-41-DE 1 3N1-QC-1/2-45 1 3N1-QC-3/8-45 1 IC-5/8-30 1 HR-10 1 Hex Wrench 1 Threaded Arbor



Phone: 989-777-5500 Fax: 989-777-0602
 E-Mail: severancetool@sbcglobal.net

Severance Tool Industries Inc. • POB 1866 • Saginaw, MI 48605

Mini-Scraper™

High Speed Steel triangular shaped scraper, ideal for removing burrs and sharp edges. Special ground surface, three sharp edges, and no teeth. High Speed Steel heat treated for durable use.

Shipped in a convenient storage tube. Should be in every Machinists tool box.

NEW!!



H.S.S.
Mini-Scraper™

Aprox. Overall Length	Cut Length	Severance Tool Name	EDP Order Number
6-1/2"	2"	Mini-Scraper™	20300

Speedy Handle™

The Severance Speed Handle™ is designed for fast efficient part deburring. A wide range of standard Severance 1/4" deburring and chamfering tools can be quickly interchanged for performing and finishing a variety of hand deburring operations.

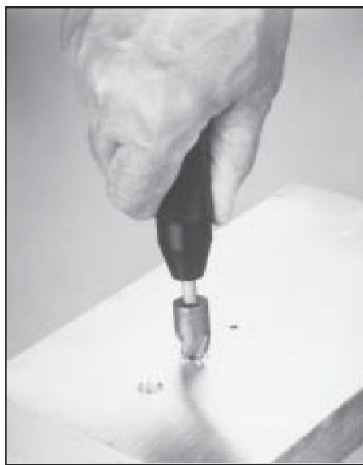

Able to take a variety of 1/4" shank standard and special tools.



Tools	EDP#
Speedy Handle™	34269



How Does The Severance Speedy Handle™ Work?

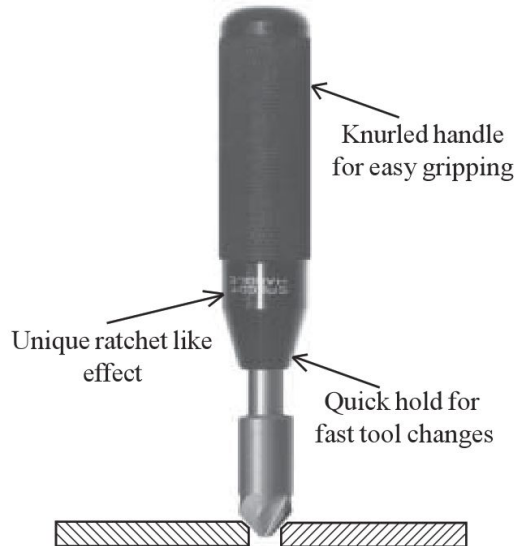

Speedy Handle™ Set 349	
EDP# 34270	
Speedy Handle™	
IIB	Ball Shaped Midget Mill®
ICS-5/8-45	Inside Chamfering Mill
ES-5/8-45-1/4	Four Flute Countersink

Severance Tool Industries, Inc.
 Manufactures Code 662018
 Website: www.severancetool.com



Phone: 989-777-5500 Fax: 989-777-0602

E-Mail: severancetool@sbcglobal.net

Severance Tool Industries Inc. • POB 1866 • Saginaw, MI 48605



Hole Radius Deburring Cutters

Rounds hole edges often an improvement over the chamfer. The multi-flute design keeps cutter centered in hole. May be used manually, mounted on a handle (see comfy grip handles below), just a twist of the wrist easily removes burrs safely from holes already sized. Also, can be shank-mounted and chucked in a machine (see shanks on pages 78-80). Safer than ordinary deburring tools. May be reground many times. Shanks and handles sold separately

High Speed Steel

Use For Nominal Hole Size	Cutting Dia.	Cutting Length	Radius	Nose Dia.	Overall Length	Internal Thread	Severance Tool Name	EDP Order Number
3/32"	3/16"	1/16"	3/32"	0.046	7/8"	1/4"-28	HR-1	25140
1/8"	9/32"	3/32"	1/8"	0.063	7/8"	1/4"-28	HR-2	25141
3/16"	3/8"	1/8"	3/16"	0.093	7/8"	1/4"-28	HR-3	25142
1/4"	9/16"	3/16"	1/4"	1/8"	3/4"	1/4"-28	HR-5	25143
5/16"	5/8"	1/4"	5/16"	3/16"	3/4"	1/4"-28	HR-10	25144
3/8"	3/4"	1/4"	3/8"	1/4"	3/4"	1/4"-28	HR-15	25145
7/16"-1/2"	1"	3/8"	3/8"	5/16"	3/4"	5/16"-24	HR-20	25146
9/16"-5/8"	1-1/8"	1/4"	1/2"	3/8"	5/8"	5/16"-24	HR-25	25147
3/4"	1-3/8"	3/8"	9/16"	7/16"	3/4"	3/8"-24	HR-30	25148
7/8"-1"	1-1/2"	3/8"	5/8"	9/16"	11/16"	3/8"-24	HR-35	25149
1-3/8"	2"	1/2"	1"	1"	3/4"	3/8"-24	HR-40	25150
1-5/8"-1-3/4"	2-1/2"	5/8"	1-1/4"	1-1/8"	1"	1/2"-20	HR-45	25151
2"	2-3/4"	3/4"	1-3/8"	1-1/2"	1-1/8"	1/2"-20	HR-50	25152



Threaded Handles

Fits This Rad. Dbr. Ctr	Severance Tool Name	EDP Order Number
HR-1	H-100	34260
HR-2	H-100	34260
HR-3	H-100	34260
HR-5	H-100	34260
HR-10	H-100	34260
HR-15	H-100	34260
HR-20	H-110	34261
HR-25	H-110	34261
HR-30	H-121	34262
HR-35	H-121	34262
HR-40	H-121	34262
HR-45	H-131	34263
HR-50	H-131	34263

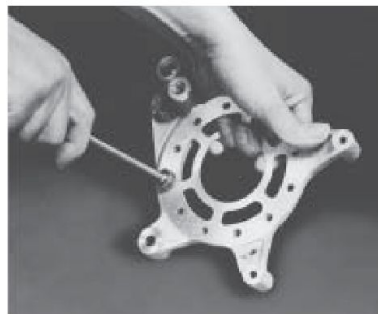

Handles generally used with radius deburr tools. For other shanks, see pages 78-80.

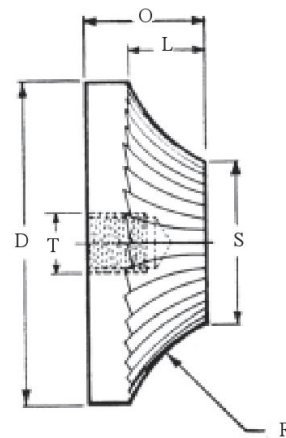



Phone: 989-777-5500 Fax: 989-777-0602
 E-Mail: severancetool@sbcglobal.net

Severance Tool Industries Inc. • POB 1866 • Saginaw, MI 48605

Rod End Forming Cutters

These cutters are used to form rounded ends on rods, wire, parts, etc. They perform well on many "Space Age" materials, as well as on the more common metals, plastics, etc. SPECIALS – Rod-End Forming Cutters may be obtained to produce various radii, straight chamfers, etc. Send sketch of desired form and sample of part, if feasible.

High Speed Steel

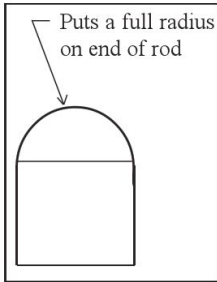

For Rod Diameter	Radius Formed	Body Dia.	Shank Dia.	Overall Length	Severance Tool Name	EDP Order Number
1/32"	1/64"	1/4"	1/4"	1-1/2"	RFC-0	28630
1/16"	1/32"	5/16"	1/4"	1-3/4"	RFC-1	28631
3/32"	3/64"	3/8"	1/4"	1-3/4"	RFC-1-1/2	28632
1/8"	1/16"	1/2"	3/8"	2-1/8"	RFC-2	28633
3/16"	3/32"	1/2"	3/8"	2-1/8"	RFC-3	28634
1/4"	1/8"	3/4"	1/2"	2-11/16"	RFC-4	28635
5/16"	5/32"	3/4"	1/2"	2-11/16"	RFC-5	28636
3/8"	3/16"	3/4"	1/2"	2-11/16"	RFC-6	28637
7/16"	7/32"	1"	1/2"	2-13/16"	RFC-7	28638
1/2"	1/4"	1"	1/2"	2-13/16"	RFC-8	28639
9/16"	9/32"	1"	1/2"	2-13/16"	RFC-9	28640
5/8"	5/16"	1-1/4"	3/4"	3-3/8"	RFC-10	28641
3/4"	3/8"	1-1/2"	3/4"	3-1/2"	RFC-12	28642
7/8"	7/16"	1-3/4"	1"	4-1/4"	RFC-14	28643
1"	1/2"	2"	1"	4-3/8"	RFC-16	28644

See Page36 for Outside Chamfer Mills to put a angle on the end of a rod

Special Rod End Forming Cutters

Special diameters, Radii, flutes, and angles available.



REF.#55362

Here is an example of a special carbide insert rod end forming cutter made by Severance Tool to fill a customers needs.



REF.#55361

Severance can make special hollow mills to fit customer applications.

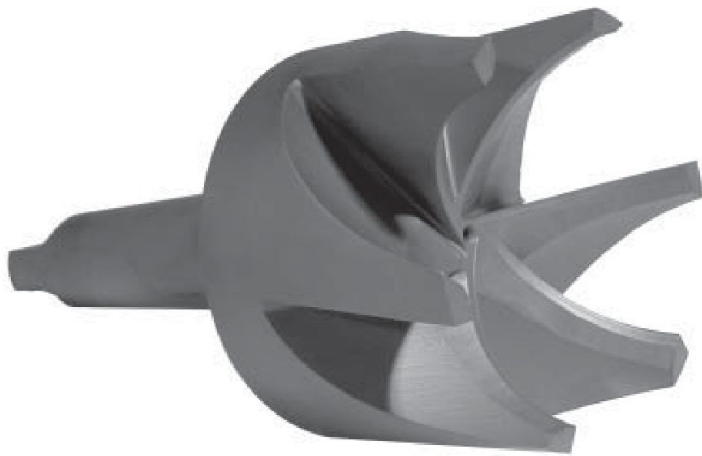

REF.#53690

Here is an example of a large Rod End Forming Cutting.

Severance® Tool Industries, Inc.
 Manufactures Code 662018
 Website: www.severancetool.com



Phone: 989-777-5500 Fax: 989-777-0602

E-Mail: severancetool@sbcglobal.net

Severance Tool Industries Inc. • POB 1866 • Saginaw, MI 48605

Disc Cutters

Severance Disc Cutters are used to replace sanding discs, snagging wheels and milling cutters on deburring applications. Unless otherwise specified, all double-face disc cutters are furnished with reversible faces. That is, only one side rotates in the cutting direction. Other disc sizes, pitches or mounting designs can be made up as specials. Severance applications engineers can recommend disc designs suitable for your type of power tool, speeds available and mounting requirements.

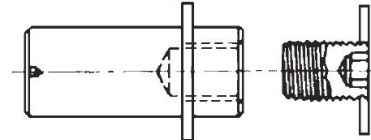
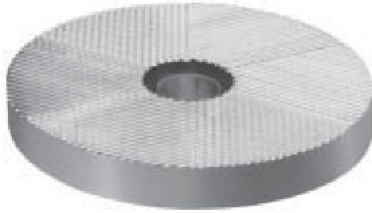
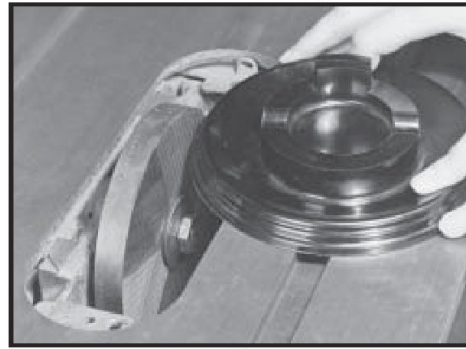

For shanks and arbors, see pages 78-80.

High Speed Steel

Dia.	Thickness	Use Arbor (See page 79)	Center Bore Dia.	Cut Number
3"	3/8"	SH-3, SH-4	3/4"	7
4"	1/2"	SH-3, SH-4	3/4"	7
5"	5/8"	SH-5	1-1/8"	8
6"	3/4"	SH-6	1-5/8"	10
8"	7/8"	SH-8	1-7/8"	12

High Speed Steel Single Face

Severance Tool Name	EDP Order Number
DISC-3-SF	17360
DISC-4-SF	17361
DISC-5-SF	17362
DISC-6-SF	17363
DISC-8-SF	17364

High Speed Steel Double Face

Severance Tool Name	EDP Order Number
DISC-3-DF	17370
DISC-4-DF	17371
DISC-5-DF	17372
DISC-6-DF	17373
DISC-8-DF	17374



Edge Deburring Cutters

Replaces laborious hand filing, scraping, grinding, etc. Severance Edging Cutters are made to deburr one face of an edge or both faces simultaneously. They are furnished with two cutting members having cutting teeth opposed and set for right hand rotation. Opposite ends of each member have faces ground to the same 75° angle with C/L without cutting teeth. By reversing one member, the safe face will act as a guide opposing the cutting member, and may be positioned to give more or less depth of cut as required.

High Speed Steel

1/4" shank w/ 3/8" mounting diameter.

Description	Cutter Dia.	Cutter Centerline Angle	Hole Dia.	Arbor Dia.	Overall Length	Severance Tool Name	EDP Order Number
Complete tool	3/4"	75°	3/8"	3/8"	4"	EG-750	17420
Complete tool	1"	75°	3/8"	3/8"	4"	EG-1000	17425

Extra or Replacement Parts

Arbor, fits both sizes				3/8"	4"	EG-750-A	17430
750F - Front cutter	3/4"	75°	3/8"		3/4"	EG-750-LC	17431
750B - Back cutter	3/4"	75°	3/8"		3/4"	EG-750-RC	17432
1000F - Front cutter	1"	75°	3/8"		7/8"	EG-1000-LC	17433
1000B - Back cutter	1"	75°	3/8"		7/8"	EG-1000-RC	17434
Socket head set screws (2 required for each cutter)					3/16"	6-32 X 1/4"	17435



Phone: 989-777-5500 Fax: 989-777-0602
 E-Mail: severancetool@sbcglobal.net

Severance Tool Industries Inc. • POB 1866 • Saginaw, MI 48605



ED-1

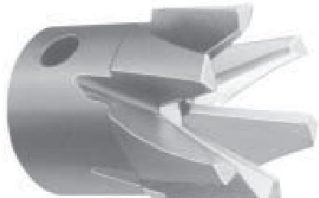

EDE-2



ED-T2

Electrode Forming Cutters For "Spot Weld" Electrodes

Reconditioning Electrode tips is an economical solution that minimizes downtime. Replacing worn tips with new electrode tips can be costly and time consuming. But reconditioning the worn tip will extend the life of your electrodes, and cuts down wasted production time.

Electrode Forming Cutters are available in threaded, extended, and flush styles.

- **Threaded (ED-1)** cutters are ideal where the center-to-center distance between electrodes is less than 1", as is the case in many multiple-point and short-stroke stationary welders. Comes with an adjustable nose flat.

- **Extended (EDE-2)** cutters are ideal where the center-to-center distance between electrodes is less than 1", as is the case in many multiple-point and short-stroke stationary welders.

- **Flush (ED-T2)** cutters allow access in confined areas, requiring a minimum clearance of only 3/4" between welding faces.

Severance can make up cutters to fit any electrode dresser holder, and to produce any desired tip shape. Severance makes high-quality double end type dressers to be used on robotics and automated machinery. Combinations of radius and angles can be produced to obtain the optimum in strength and repeated high quality welds. To request a quotation on nonstandard cutters, please specify equipment used and provide a sketch of the required tip shape.

See Special Forms Page 65-66

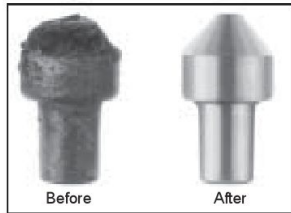

Before

After

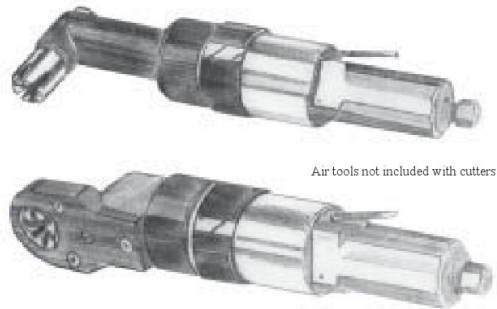

Air tools not included with cutters

High Speed Steel

Threaded Style Electrode Forming Cutter

Shape Centerline Angle	Dia. of Flat Nose Cutting Insert And Comb. Stop	Severance Tool Name	EDP Order Number
30°	3/16"	ED-1	17470
30°	1/8"	ED-2	17471

High Speed Steel

Extended Style Electrode Forming Cutter

Shape Centerline Angle	Dia. of Flat Nose Cutting Insert And Comb. Stop	Severance Tool Name	EDP Order Number
30°	1/8"	EDE-1	17490
30°	3/16"	EDE-2	17491
30°	1/4"	EDE-3	17492
5/16 Radius	1/4"	EDE-6	17493

High Speed Steel

Flush Style Electrode Forming Cutter

Shape Centerline Angle	Dia. of Flat Nose Cutting Insert And Comb. Stop	Severance Tool Name	EDP Order Number
Reform No. 1 Pointed Tips	3/16"	ED-T1	17530
Reform No. 2 Pointed Tips	1/4"	ED-T2	17531

Severance Tool Industries, Inc.
 Manufactures Code 662018
 Website: www.severancetool.com



Phone: 989-777-5500 Fax: 989-777-0602

E-Mail: severancetool@sbcglobal.net

Severance Tool Industries Inc. • POB 1866 • Saginaw, MI 48605

Specialty Electrode Cutter Forms

For "Spot Weld" Electrodes (For styles/shapes of actual cutters, see bottom of next page).

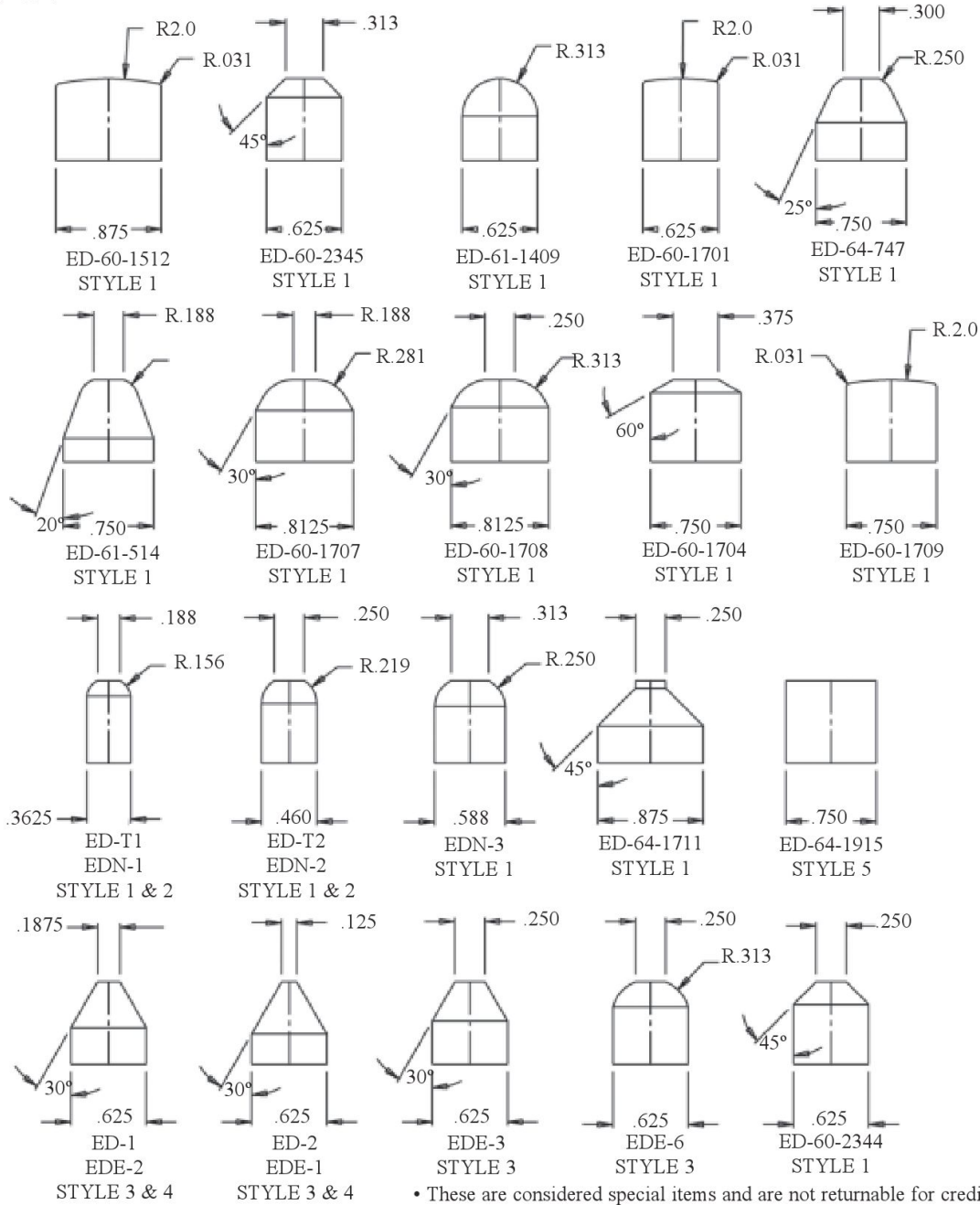



Phone: 989-777-5500 Fax: 989-777-0602

E-Mail: severancetool@sbcglobal.net

Severance Tool Industries Inc. • POB 1866 • Saginaw, MI 48605

Specialty Electrode Cutter Forms (Continued..)

For "Spot Weld" Electrodes (For styles/shapes of actual cutters, see bottom of page).

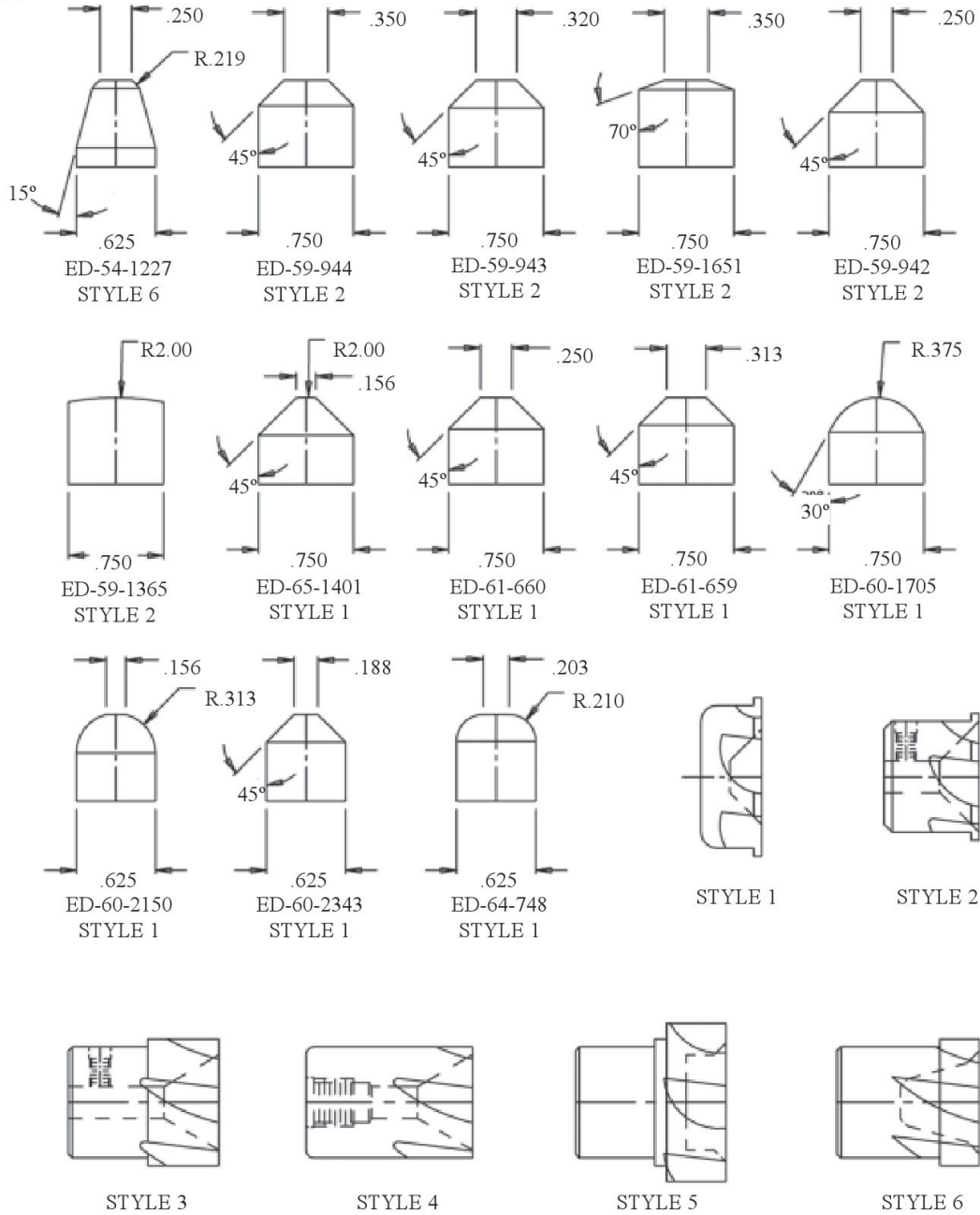

• These are considered special items and are not returnable for credit.

Severance® Tool Industries, Inc.
 Manufactures Code 662018
 Website: www.severancetool.com

Severance®

Phone: 989-777-5500 Fax: 989-777-0602

E-Mail: severancetool@sbcglobal.net

Severance Tool Industries Inc. • POB 1866 • Saginaw, MI 48605

A Countersink For Every Use

Severance Tool Industries, Inc. manufactures countersinks with one, four and six flutes, carbide and high speed steel, countersinks with pilots and drill points, heavy-duty tools and specials. Sizes range from 1/8" to 3", and almost any centerline angle can be specified. These standard tools will handle at least 99% of all countersinking applications ... and we can build specials to satisfy any other need.

Carbide or Steel?

When machining hard or abrasive materials, carbide countersinks will often give 10 or more times the service life of high speed steel tools. As a rule of thumb, consider carbide for production operations with cast iron, alloy steel or glass-reinforced plastics. High speed steel is generally more economical in low carbon steel and nonferrous machining applications. In automated production operations, the cost of changing a tool can exceed the cost of the tool. Consider long-running carbide in such situations.

1, 4, or 6 Flutes?

In general, a six-fluted countersink will remove more material per revolution than will a four-flute or single-flute tool. While the single-flute countersink is slow cutting, it will work well in a non-rigid machining setup. Four flutes provide more chip clearance than six do. This is a consideration in machining stringy materials such as some plastics and nonferrous alloys. Other factors being equal, the six-flute countersink will give more service life than the four-flute tool because the cutting load is distributed over more edges.

Chatterless™ Design

Resonant vibration is the cause of chatter in rotating cutting tools. Every tool/machine/workpiece system has natural frequencies at which such vibration will occur. Severance countersinks are designed with staggered cutting edges, which inhibit the occurrence of resonant, or harmonic vibration. Tools with symmetrical cutting edges tend to multiply the frequencies at which chatter occurs, and to reinforce the vibration. Chatterless™ design can't change the natural frequencies of the system, but it takes tool geometry out of the problem.

Proprietary Countersinks for Special Jobs

What makes the Severance line unique is the number of proprietary and special tools we can supply to fit some specific applications.

- **3N1® Drill Points** (see page 57 - 59) offer some cost-cutting opportunities to the creative tool engineer.
- **CNC-K™ Precision Countersinks** (pages 53 - 54) are used in numerical control and other preset tooling systems. Such applications exist in almost any modern production machining facility.
- **Stop Countersink Systems** (pages 64-67) are in wide use in the aircraft industry, where they are used with hand-held power tools to countersink rivet holes.
- **Special Tools** which combine countersinks with drills, steps, pilots, radii and other custom shapes are readily available from Severance. Just send in a sketch or description for quotation.

Regrinding Countersinks

Very few tool rooms or sharpening services are equipped to recondition worn chatterless™ countersinks. Our regrinding service is fast, competent and economical. Whenever you sell chatterless cutters, be sure to recommend Severance regrinding.

Please note when ordering Severance countersinks. We go by centerline angle not included.

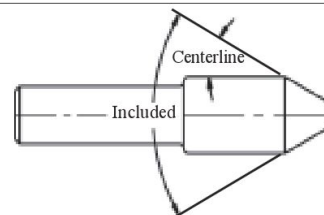

Example: Severance CK-1/2-30° is 60° included.

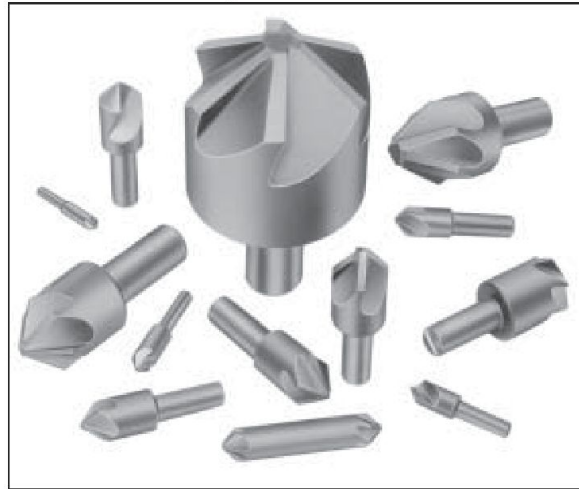



Phone: 989-777-5500 Fax: 989-777-0602
 E-Mail: severancetool@sbcglobal.net

Severance Tool Industries Inc. • POB 1866 • Saginaw, MI 48605



All Carbide Countersinks over 1-1/2" diameter are individually tipped teeth.

The Original 6-Flute Chatterless-Countersinks™

Developed by Severance Tool, the flutes of the 6-flute Chatterless-Countersinks™ are designed with staggered cutting angles to eliminate the harmonics that cause chatter in conventional tools. Our tools feature a positive shearing action, are designed to take heavy cuts and produce exceptionally smooth seats. These six fluted countersinks give long service life because the cutting load is distributed over six cutting edges.

Use them in your milling machine, drill press, screw machine, lathes, automatics, special machines, feed units, and hand tools. See also page 53-54 for our CNC-K™ Chatterless-Countersinks™ for CNC lathes and Machining Centers. Our countersinks may be factory resharpened many times, see pages 89-90.

Available in a wide range of standard angles and sizes, or submit your request for special angles, diameters, double angles, pilots, or radii to our Engineering Dept.

High Speed Steel

We're The Originators! We've Been "Copied" But Not Surpassed.

Head Dia.	Shank Dia.	Overall Length	Shank Length	Centerline Angle											
				30°		41°		45°		50°		55°		60°	
				Included Angle		82°		90°		100°		110°		120°	
				Severance Name	Order Number	Order Number	Order Number	Order Number	Order Number	Order Number	Order Number	Order Number			
1/8"	1/8"	1-5/8"	1-5/8"	CK-1/8	02370	02390	02410	02430	02450	02470					
3/16"	3/16"	1-1/2"	1-1/2"	CK-3/16	02371	02391	02411	02431	02451	02471					
1/4"	3/16"	1-1/2"	3/4"	CK-1/4	02372	02392	02412	02432	02452	02472					
5/16"	1/4"	1-3/4"	7/8"	CK-5/16	02373	02393	02413	02433	02453	02473					
3/8"	1/4"	1-3/4"	7/8"	CK-3/8	02374	02394	02414	02434	02454	02474					
1/2"	3/8"	2-1/8"	1-1/8"	CK-1/2	02375	02395	02415	02435	02455	02475					
1/2"	1/4"	2-1/8"	1-1/8"	CK-1/2-1/4	02376	02396	02416	02436	02456	02476					
5/8"	3/8"	2-3/8"	1-1/8"	CK-5/8	02377	02397	02417	02437	02457	02477					
5/8"	1/4"	2-3/8"	1-1/8"	CK-5/8-1/4	02378	02398	02418	02438	02458	02478					
3/4"	1/2"	2-11/16"	1-5/16"	CK-3/4	02379	02399	02419	02439	02459	02479					
7/8"	1/2"	2-13/16"	1-5/16"	CK-7/8	02380	02400	02420	02440	02460	02480					
1"	1/2"	2-13/16"	1-5/16"	CK-1	02381	02401	02421	02441	02461	02481					
1-1/4"	3/4"	3-3/8"	1-5/8"	CK-1-1/4	02382	02402	02422	02442	02462	02482					
1-1/2"	3/4"	3-1/2"	1-5/8"	CK-1-1/2	02383	02403	02423	02443	02463	02483					
1-3/4"	1"	4-1/4"	2-1/8"	CK-1-3/4	02384	02404	02424	02444	02464	02484					
2"	1"	4-3/8"	2-1/8"	CK-2	02385	02405	02425	02445	02465	02485					
2-1/2"	1"	4-3/4"	2-1/8"	CK-2-1/2	02386	02406	02426	02446	02466	02486					
3"	1"	5"	2-1/8"	CK-3	02387	02407	02427	02447	02467	02487					

Carbide

Head Dia.	Shank Dia.	Overall Length	Shank Length	Centerline Angle											
				30°		41°		45°		50°		55°		60°	
				Included Angle		82°		90°		100°		110°		120°	
				Severance Name	Order Number	Order Number	Order Number	Order Number	Order Number	Order Number	Order Number	Order Number			
1/8"	1/8"	1-1/2"	1-1/2"	CK-1/8-W	02520	02540	02560	02580	02600	02620					
3/16"	3/16"	1-1/2"	1-1/2"	CK-3/16-W	02521	02541	02561	02581	02601	02621					
1/4"	3/16"	1-1/2"	1-3/16"	CK-1/4-W	02522	02542	02562	02582	02602	02622					
5/16"	1/4"	2-1/4"	1-3/4"	CK-5/16-W	02523	02543	02563	02583	02603	02623					
3/8"	1/4"	2-1/4"	1-3/4"	CK-3/8-W	02524	02544	02564	02584	02604	02624					
1/2"	3/8"	2-1/2"	2"	CK-1/2-W	02525	02545	02565	02585	02605	02625					
1/2"	1/4"	2-1/4"	1-3/4"	CK-1/2-W-1/4	02526	02546	02566	02586	02606	02626					
5/8"	3/8"	2-5/8"	2"	CK-5/8-W	02527	02547	02567	02587	02607	02627					
5/8"	1/4"	2-3/8"	1-3/4"	CK-5/8-W-1/4	02528	02548	02568	02588	02608	02628					
3/4"	1/2"	2-3/4"	2"	CK-3/4-W	02529	02549	02569	02589	02609	02629					
7/8"	1/2"	2-7/8"	2"	CK-7/8-W	02530	02550	02570	02590	02610	02630					
1"	1/2"	3"	2"	CK-1-W	02531	02551	02571	02591	02611	02631					
1-1/4"	3/4"	3-3/8"	1-5/8"	CK-1-1/4-W	02532	02552	02572	02592	02612	02632					
1-1/2"	3/4"	3-1/2"	1-5/8"	CK-1-1/2-W	02533	02553	02573	02593	02613	02633					
1-3/4"	1"	4-1/4"	2-1/8"	CK-1-3/4-W	02534	02554	02574	02594	02614	02634					
2"	1"	4-3/8"	2-1/8"	CK-2-W	02535	02555	02575	02595	02615	02635					

Severance Tool Industries, Inc.
 Manufactures Code 662018
 Website: www.severancetool.com



Phone: 989-777-5500 Fax: 989-777-0602
 E-Mail: severancetool@sbcglobal.net

Severance Tool Industries Inc. • POB 1866 • Saginaw, MI 48605



The Original 6-Flute Double Ended Chatterless-Countersinks™

Reduces tooling investment, since one dual-ended countersink costs less than the alternative two single end tools. These tools feature our positive shear cutting edge and six staggered flutes to reduce chatter.

High Speed Steel

Head Dia.	Overall Length	Centerline Angle		30°	41°	45°	50°	55°	60°
		Included Angle		60°	82°	90°	100°	110°	120°
		Severance Name	Order Number	Order Number	Order Number	Order Number	Order Number	Order Number	
1/8"	1-1/2"	CK-1/8-DE	02670	02685	02700	02715	02730	02745	
3/16"	1-7/8"	CK-3/16-DE	02671	02686	02701	02716	02731	02746	
1/4"	2"	CK-1/4-DE	02672	02687	02702	02717	02732	02747	
5/16"	2-1/8"	CK-5/16-DE	02673	02688	02703	02718	02733	02748	
3/8"	2-1/2"	CK-3/8-DE	02674	02689	02704	02719	02734	02749	
1/2"	3"	CK-1/2-DE	02675	02690	02705	02720	02735	02750	
5/8"	3-1/4"	CK-5/8-DE	02676	02691	02706	02721	02736	02751	
3/4"	3-1/2"	CK-3/4-DE	02677	02692	02707	02722	02737	02752	

Carbide

Head Dia.	Overall Length	Centerline Angle		30°	41°	45°	50°	55°	60°
		Included Angle		60°	82°	90°	100°	110°	120°
		Severance Name	Order Number	Order Number	Order Number	Order Number	Order Number	Order Number	
1/8"	1-1/2"	CK-1/8-W-DE	02820	02835	02850	02865	02880	02895	
3/16"	2"	CK-3/16-W-DE	02821	02836	02851	02866	02881	02896	
1/4"	2"	CK-1/4-W-DE	02822	02837	02852	02867	02882	02897	
5/16"	2-1/8"	CK-5/16-W-DE	02823	02838	02853	02868	02883	02898	
3/8"	2-1/2"	CK-3/8-W-DE	02824	02839	02854	02869	02884	02899	
1/2"	3"	CK-1/2-W-DE	02825	02840	02855	02870	02885	02900	
5/8"	3-1/4"	CK-5/8-W-DE	02826	02841	02856	02871	02886	02901	
3/4"	3-1/2"	CK-3/4-W-DE	02827	02842	02857	02872	02887	02902	

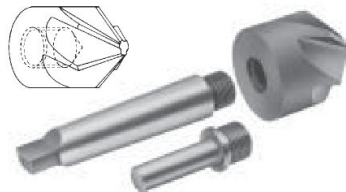

The Original 6-Flute Threaded Chatterless-Countersinks™

These countersink have a threaded back for use with separately ordered shanks. Ideal for use on radial drills, lathes, and Mills.

High Speed Steel

Head Dia.	Overall Length	Thread Size	Centerline Angle		30°	41°	45°	50°	55°	60°
			Included Angle		60°	82°	90°	100°	110°	120°
			Severance Name	Order Number	Order Number	Order Number	Order Number	Order Number	Order Number	
3/4"	1-1/2"	3/8"-24	CK-3/4-T	03270	03280	03290	03300	03310	03320	
7/8"	1-1/2"	3/8"-24	CK-7/8-T	03271	03281	03291	03301	03311	03321	
1"	1-1/2"	1/2"-20	CK-1-T	03272	03282	03292	03302	03312	03322	
1-1/4"	1-3/4"	5/8"-18	CK-1-1/4-T	03273	03283	03293	03303	03313	03323	
1-1/2"	1-7/8"	3/4"-16	CK-1-1/2-T	03274	03284	03294	03304	03314	03324	
1-3/4"	2-1/8"	3/4"-16	CK-1-3/4-T	03275	03285	03295	03305	03315	03325	
2"	2-1/4"	3/4"-16	CK-2-T	03276	03286	03296	03306	03316	03326	
2-1/2"	3"	1"-14	CK-2-1/2-T	03277	03287	03297	03307	03317	03327	
3"	3-1/4"	1-1/4"-12	CK-3-T	03278	03288	03298	03308	03318	03328	

See pages 78-80 for other available shank styles and sizes.



Phone: 989-777-5500 Fax: 989-777-0602
 E-Mail: severancetool@sbcglobal.net

Severance Tool Industries Inc. • POB 1866 • Saginaw, MI 48605



Style "F"



Style "N"

6-Flute Heavy Duty Chatterless – Countersinks™

For heavy-duty work in conjunction with the Glenzer sleeve on drill presses, lathes, screw-machines, etc. These countersinks are designed to take heavy cuts and at the same time produce a very smooth seat. These heavy-duty tools are available in two styles without flutes (style N) and with flutes (style F). Ideal for use in bushings, Other angles are available as specials.

High Speed Steel

Head Dia.	Shank Dia.	Overall Length	Shank Length	Centerline Angle				
				Included		30°	41°	45°
				Severance Name	Order Number	Order Number	Order Number	
3/8"	13/32"	2-13/16"	1-7/16"	HD-3/8-N	03920	03940	03960	
3/8"	13/32"	2-13/16"	1-7/16"	HD-3/8-F	03921	03941	03961	
1/2"	13/32"	3-1/16"	1-11/16"	HD-1/2-N	03922	03942	03962	
1/2"	13/32"	3-1/16"	1-11/16"	HD-1/2-F	03923	03943	03963	
3/4"	3/4"	3-7/8"	2-1/8"	HD-3/4-N	03924	03944	03964	
3/4"	3/4"	3-7/8"	2-1/8"	HD-3/4-F	03925	03945	03965	
1"	3/4"	4-5/16"	1-3/4"	HD-1-N	03926	03946	03966	
1"	3/4"	4-5/16"	1-3/4"	HD-1-F	03927	03947	03967	
1-1/4"	1"	5"	2-1/4"	HD-1-1/4-N	03928	03948	03968	
1-1/4"	1"	5"	2-1/4"	HD-1-1/4-F	03929	03949	03969	
1-1/2"	1"	5-1/4"	2-1/4"	HD-1-1/2-N	03930	03950	03970	
1-1/2"	1"	5-1/4"	2-1/4"	HD-1-1/2-F	03931	03951	03971	
2"	1"	5-3/4"	2-1/4"	HD-2-N	03932	03952	03972	
2"	1"	5-3/4"	2-1/4"	HD-2-F	03933	03953	03973	



Steel



O.D. Taper	Fits Shank Diameter	Glenzer NO.	EDP Order Number
2 M.T.	13/32"	778932	36210
3 M.T.	3/4"	778954	36211
4 M.T.	1"	778970	36212

Glenzer Sleeve

To be used with Severance Heavy Duty Countersinks above and straight tanged shanks seen on page 76.



6-Flute Chatterless – Countersinks™ for Wheels

Severance developed the Chatterless™ Wheel Countersinks for use in the wheel manufacturing industry. Available in Heavy Duty style F and N, and our standard style tools. Our tools have been used on Semi truck and trailer wheels. For use on off the road wheels, heavy equipment wheels, car and truck wheels, custom wheels, break drums, wheel components, hubs, trailer wheels, and motorcycle wheels to produce a smooth seat and angle for the lug nuts. Custom designed for each specific application, diameter, angle, form and radius in High Speed Steel, Carbide, or Coated.

Severance Tool Industries, Inc.
 Manufactures Code 662018
 Website: www.severancetool.com



Phone: 989-777-5500 Fax: 989-777-0602

E-Mail: severancetool@sbcglobal.net

Severance Tool Industries Inc. • POB 1866 • Saginaw, MI 48605



See Page 87 for programming and setup assistance

CNC-K™ Precision Chatterless-Countersinks™

Designed for use in NC, CNC, Vertical and Horizontal, also CNC Lathes, and Multi Axis machines. These Precision countersinks feature our 6 flute Chatterless™ tooth geometry. Tighter tolerances on angles, diameters, and lengths assure setting accuracy. See page 87 for programming and setup assistance.

High Speed Steel

BODY DIA.	NOSE DIA. +.001-.000	SHANK DIA.	OVERALL LENGTH	SHANK LENGTH	CENTERLINE ANGLE INCLUDED ANGLE	30°	41°	45°	50°	55°	60°
						SEVERANCE NAME	ORDER NUMBER	ORDER NUMBER	ORDER NUMBER	ORDER NUMBER	ORDER NUMBER
1/4"	.078	3/16"	1-1/2"	3/4"	60°	CNC-K-1/4	02970	-	-	-	-
1/4"	.046	3/16"	1-1/2"	3/4"	82°	CNC-K-1/4	-	02980	02990	03000	03010 03020
3/8"	.125	1/4"	1-3/4"	7/8"	90°	CNC-K-3/8	02971	-	-	-	-
3/8"	.078	1/4"	1-3/4"	7/8"	100°	CNC-K-3/8	-	02981	02991	03001	-
3/8"	.062	1/4"	1-3/4"	7/8"	110°	CNC-K-3/8	-	-	-	03011	03021
1/2"	.156	3/8"	2-1/8"	1-1/8"	120°	CNC-K-1/2	02972	-	-	-	-
1/2"	.109	3/8"	2-1/8"	1-1/8"		CNC-K-1/2	-	02982	02992	03002	-
1/2"	.078	3/8"	2-1/8"	1-1/8"		CNC-K-1/2	-	-	-	03012	03022
5/8"	.203	3/8"	2-3/8"	1-1/8"		CNC-K-5/8	02973	-	-	-	-
5/8"	.125	3/8"	2-3/8"	1-1/8"		CNC-K-5/8	-	02983	02993	03003	-
5/8"	.109	3/8"	2-3/8"	1-1/8"		CNC-K-5/8	-	-	-	03013	03023
3/4"	.250	1/2"	2-11/16"	1-5/16"		CNC-K-3/4	02974	-	-	-	-
3/4"	.156	1/2"	2-11/16"	1-5/16"		CNC-K-3/4	-	02984	02994	03004	-
3/4"	.125	1/2"	2-11/16"	1-5/16"		CNC-K-3/4	-	-	-	03014	03024
7/8"	.281	1/2"	2-13/16"	1-5/16"		CNC-K-7/8	02975	-	-	-	-
7/8"	.172	1/2"	2-13/16"	1-5/16"		CNC-K-7/8	-	02985	02995	03005	-
7/8"	.140	1/2"	2-13/16"	1-5/16"		CNC-K-7/8	-	-	-	03015	03025
1"	.328	1/2"	2-13/16"	1-5/16"		CNC-K-1	02976	-	-	-	-
1"	.203	1/2"	2-13/16"	1-5/16"		CNC-K-1	-	02986	02996	03006	-
1"	.171	1/2"	2-13/16"	1-5/16"		CNC-K-1	-	-	-	03016	03026



See Page 87 for programming and setup assistance

CNC-K™ Precision Double Ended Countersinks

These precision countersinks have our 6-Flute chatterless™ design. Double-Ended Countersinks can help reduce manufacturing costs by lowering tool inventories and labor costs. When one end of the countersink dulls, simply reverse the tool and continue machining operations.

High Speed Steel

Head Dia.	Overall Length	Nose Dia.	Severance Name	Centerline Angle	30°	41°	45°	50°	55°	60°
				Included Angle	60°	82°	90°	100°	110°	120°
1/8"	1-1/2"	See single ended above for nose flats	CNC-K-1/8-DE	Order Number	03177	03185	03193	03201	03209	03217
3/16"	1-7/8"		CNC-K-3/16-DE	Order Number	03178	03186	03194	03202	03210	03218
1/4"	2"		CNC-K-1/4-DE	Order Number	03179	03187	03195	03203	03211	03219
5/16"	2-1/8"		CNC-K-5/16-DE	Order Number	03180	03188	03196	03204	03212	03220
3/8"	2-1/2"	for nose flats	CNC-K-3/8-DE	Order Number	03181	03189	03197	03205	03213	03221
1/2"	3"		CNC-K-1/2-DE	Order Number	03182	03190	03198	03206	03214	03222
5/8"	3-1/4"		CNC-K-5/8-DE	Order Number	03183	03191	03199	03207	03215	03223
3/4"	3-1/2"		CNC-K-3/4-DE	Order Number	03184	03192	03200	03208	03216	03224



Phone: 989-777-5500 Fax: 989-777-0602
 E-Mail: severancetool@sbcglobal.net

Severance Tool Industries Inc. • POB 1866 • Saginaw, MI 48605



See Page 87 for programming and setup assistance

CNC-K™ Precision Chatterless-Countersinks™

Designed for use in NC, CNC, Vertical and Horizontal, also CNC Lathes, and Multi Axis machines. These Precision countersinks feature our 6 flute Chatterless™ tooth geometry. Tighter tolerances on angles, diameters, and lengths assure setting accuracy. See page 87 for programing and setup assistance.

Carbide

BODY DIA.	NOSE DIA. +.001-.000	SHANK DIA.	OVERALL LENGTH	SHANK LENGTH	CENTERLINE ANGLE INCLUDED ANGLE	30°	41°	45°	50°	55°	60°
						60°	82°	90°	100°	110°	120°
						SEVERANCE NAME	ORDER NUMBER	ORDER NUMBER	ORDER NUMBER	ORDER NUMBER	ORDER NUMBER
1/4"	.078	3/16"	1-1/2"	1-3/16"	CNC-K-1/4-W	03120	-	-	-	-	-
1/4"	.046	3/16"	1-1/2"	1-3/16"	CNC-K-1/4-W	-	03130	03140	03150	03160	03170
3/8"	.125	1/4"	2-1/4"	1-3/4"	CNC-K-3/8-W	03121	-	-	-	-	-
3/8"	.078	1/4"	2-1/4"	1-3/4"	CNC-K-3/8-W	-	03131	03141	03151	-	-
3/8"	.062	1/4"	2-1/4"	1-3/4"	CNC-K-3/8-W	-	-	-	-	03161	03171
1/2"	.156	3/8"	2-1/2"	2"	CNC-K-1/2-W	03122	-	-	-	-	-
1/2"	.109	3/8"	2-1/2"	2"	CNC-K-1/2-W	-	03132	03142	03152	-	-
1/2"	.078	3/8"	2-1/2"	2"	CNC-K-1/2-W	-	-	-	-	03162	03172
5/8"	.203	3/8"	2-5/8"	2"	CNC-K-5/8-W	03123	-	-	-	-	-
5/8"	.125	3/8"	2-5/8"	2"	CNC-K-5/8-W	-	03133	03143	03153	-	-
5/8"	.109	3/8"	2-5/8"	2"	CNC-K-5/8-W	-	-	-	-	03163	03173
3/4"	.250	1/2"	2-3/4"	2"	CNC-K-3/4-W	03124	-	-	-	-	-
3/4"	.156	1/2"	2-3/4"	2"	CNC-K-3/4-W	-	03134	03144	03154	-	-
3/4"	.125	1/2"	2-3/4"	2"	CNC-K-3/4-W	-	-	-	-	03164	03174
7/8"	.281	1/2"	2-7/8"	2"	CNC-K-7/8-W	03125	-	-	-	-	-
7/8"	.172	1/2"	2-7/8"	2"	CNC-K-7/8-W	-	03135	03145	03155	-	-
7/8"	.140	1/2"	2-7/8"	2"	CNC-K-7/8-W	-	-	-	-	03165	03175
1"	.328	1/2"	3"	2"	CNC-K-1-W	03126	-	-	-	-	-
1"	.203	1/2"	3"	2"	CNC-K-1-W	-	03136	03146	03156	-	-
1"	.171	1/2"	3"	2"	CNC-K-1-W	-	-	-	-	03166	03176



See Page 87 for programming and setup assistance

CNC-K™ Precision Double Ended Countersinks

These precision countersinks have our 6-Flute Chatterless™ design. Double-Ended Countersinks can help reduce manufacturing costs by lowering tool inventories and labor costs. When one end of the countersink dulls, simply reverse the tool and continue machining operations.

Carbide

Head Dia.	Overall Length	Nose Dia.	Severance Name	Centerline Angle	30°	41°	45°	50°	55°	60°
				Included Angle	60°	82°	90°	100°	110°	120°
				Order Number	Order Number	Order Number	Order Number	Order Number	Order Number	Order Number
1/8"	1-1/2"	See single ended above for nose flats	CNC-K-1/8-W-DE	03423	03431	03439	03447	03455	03463	
3/16"	1-7/8"		CNC-K-3/16-W-DE	03424	03432	03440	03448	03456	03464	
1/4"	2"		CNC-K-1/4-W-DE	03425	03433	03441	03449	03457	03465	
5/16"	2-1/8"		CNC-K-5/16-W-DE	03426	03434	03442	03450	03458	03466	
3/8"	2-1/2"	for nose flats	CNC-K-3/8-W-DE	03427	03435	03443	03451	03459	03467	
1/2"	3"		CNC-K-1/2-W-DE	03428	03436	03444	03452	03460	03468	
5/8"	3-1/4"		CNC-K-5/8-W-DE	03429	03437	03445	03453	03461	03469	
3/4"	3-1/2"		CNC-K-3/4-W-DE	03430	03438	03446	03454	03462	03470	

Severance Tool Industries, Inc.
 Manufactures Code 662018
 Website: www.severancetool.com



Phone: 989-777-5500 Fax: 989-777-0602

E-Mail: severancetool@sbcglobal.net

Severance Tool Industries Inc. • POB 1866 • Saginaw, MI 48605



Multi-Flute Countersinks

Teeth as regularly furnished on these cutters are for quick light chamfering only. Stocked in 30° C/L and 45° C/L. The Inside Deburring Cutter is designed so that one tool can deburr many different hole diameters. The multi-flute design is self-piloting. For heavier countersinking, special arbors, or special angles, submit details to our Engineering Department.

High Speed Steel 30° C/L (60° Included) Solid

Head Dia.	Nose Point or Flat Dia.	Overall Length	Severance Tool Name	EDP Order Number
1/4"	P	2-1/4"	ID-1/4-30	20770
5/16"	1/32"	2-1/4"	ID-5/16-30	20771
3/8"	P	2-1/4"	ID-3/8-30	20772
1/2"	9/64"	2-1/4"	IDS-1/2-30	20773
1/2"	P	2-1/4"	IDL-1/2-30	20774
5/8"	13/64"	2-1/4"	IDS-5/8-30	20775

High Speed Steel 45° C/L (90° Included) Solid

Head Dia.	Nose Point or Flat Dia.	Overall Length	Severance Tool Name	EDP Order Number
1/4"	P	2-1/4"	ID-1/4-45	20805
5/16"	1/16"	2-1/4"	ID-5/16-45	20806
3/8"	P	2-1/4"	ID-3/8-45	20807
1/2"	1/8"	2-1/4"	IDS-1/2-45	20808
1/2"	P	2-1/4"	IDL-1/2-45	20809
5/8"	1/8"	2-1/4"	IDS-5/8-45	20810



Tools are furnished without shanks.
See pages 78-80 for available shank styles and sizes.

High Speed Steel 30° C/L (60° Included) Threaded

Head Dia.	Nose Point or Flat Dia.	Overall Length	Thread Size	Severance Tool Name	EDP Order Number
5/8"	3/64"	7/8"	1/4"-28	ID-5/8-30	20776
3/4"	1/32"	1"	5/16"-24	ID-3/4-30	20777
7/8"	5/32"	1"	3/8"-24	ID-7/8-30	20778
1"	9/32"	1-1/8"	3/8"-24	IDS-1-30	20779
1"	1/8"	1-1/8"	3/8"-24	IDL-1-30	20780
1-1/8"	1/8"	1-1/8"	3/8"-24	ID-1-1/8-30	20781
1-1/4"	17/32"	1"	3/8"-24	IDS-1-1/4-30	20782
1-1/4"	3/32"	1-1/4"	3/8"-24	IDL-1-1/4-30	20783
1-1/2"	31/64"	1-1/8"	1/2"-20	IDS-1-1/2-30	20784
1-1/2"	13/64"	1-1/2"	1/2"-20	IDL-1-1/2-30	20785
1-3/4"	3/4"	1-1/4"	1/2"-20	IDS-1-3/4-30	20786
1-3/4"	5/16"	1-1/2"	1/2"-20	IDL-1-3/4-30	20787
2"	63/64"	1-1/4"	5/8"-18	IDS-2-30	20788
2"	27/32"	1-1/4"	5/8"-18	IDL-2-30	20789
2-1/4"	1-3/32"	1-3/8"	3/4"-16	IDS-2-1/4-30	20790
2-1/4"	33/64"	1-7/8"	3/4"-16	IDL-2-1/4-30	20791
2-1/2"	1-31/64"	1-1/4"	3/4"-16	IDS-2-1/2-30	20792
2-1/2"	29/32"	1-3/4"	3/4"-16	IDL-2-1/2-30	20793
3"	1-63/64"	1-1/4"	1"-14	ID-3-30	20794

High Speed Steel 45° C/L (90° Included) Threaded

Head Dia.	Nose Point or Flat Dia.	Overall Length	Thread Size	Severance Tool Name	EDP Order Number
5/8"	1/8"	11/16"	1/4"-28	ID-5/8-45	20811
3/4"	P	13/16"	5/16"-24	ID-3/4-45	20812
7/8"	5/32"	1"	3/8"-24	ID-7/8-45	20813
1"	1/4"	7/8"	3/8"-24	IDS-1-45	20814
1"	P	7/8"	3/8"-24	IDL-1-45	20815
1-1/4"	3/8"	3/4"	3/8"-24	IDS-1-1/4-45	20816
1-1/4"	P	1"	3/8"-24	IDL-1-1/4-45	20817
1-1/2"	1/2"	7/8"	1/2"-20	IDS-1-1/2-45	20818
1-1/2"	1/4"	1-1/16"	1/2"-20	IDL-1-1/2-45	20819
1-3/4"	5/8"	7/8"	1/2"-20	ID-1-3/4-45	20820
2"	1"	1"	5/8"-18	IDS-2-45	20821
2"	1/4"	1-1/2"	5/8"-18	IDL-2-45	20822
2-1/4"	1"	1"	5/8"-18	IDS-2-1/4-45	20823
2-1/4"	1/4"	1-3/8"	5/8"-18	IDL-2-1/4-45	20824
2-1/2"	3/4"	1-3/8"	3/4"-16	IDS-2-1/2-45	20825
2-1/2"	1/4"	1-5/8"	3/4"-16	IDL-2-1/2-45	20826
3"	3/4"	1-3/4"	1"-14	IDS-3-45	20827
3"	1/4"	1-7/8"	1"-14	IDL-3-45	20828



Phone: 989-777-5500 Fax: 989-777-0602
 E-Mail: severancetool@sbcglobal.net

Severance Tool Industries Inc. • POB 1866 • Saginaw, MI 48605



Multi-Flute Countersinks

All carbide Inside Deburring Cutters are designed with a pointed nose. Tools with a head diameter measuring 3/32" thru 1/4" are made of solid carbide and are double ended. Inside Deburring Cutters with a head diameter measuring 5/16" thru 1" have solid carbide heads brazed to hardened alloy precision ground shanks.

Carbide

30° C/L (60° Included)

Carbide

45° C/L (90° Included)

Head Dia.	Shank Dia.	Overall Length	Severance Tool Name	EDP Order Number	Severance Tool Name	EDP Order Number
3/32"	3/32"	1-1/2"	3Z-W-DE	20620	3Y-W-DE	20680
1/8"	1/8"	1-1/2"	4Z-W-DE	22250	4Y-W-DE	22249
3/16"	3/16"	2"	6Z-W-DE	20622	6Y-W-DE	20682
1/4"	1/4"	2"	8Z-W-DE	22411	8Y-W-DE	22412
5/16"	1/4"	2-1/4"	ID-5/16-30-W	20628	ID-5/16-45-W	20688
3/8"	1/4"	2-1/4"	ID-3/8-30-W	20629	ID-3/8-45-W	20689
1/2"	1/4"	2-1/4"	ID-1/2-30-W	20633	ID-1/2-45-W	20693
1/2"	3/8"	2-1/8"	ID-1/2-30-W-3/8	20634	ID-1/2-45-W-3/8	20694
5/8"	1/4"	2-3/8"	ID-5/8-30-W	20639	ID-5/8-45-W	20699
5/8"	3/8"	2-3/8"	ID-5/8-30-W-3/8	20640	ID-5/8-45-W-3/8	20700
3/4"	1/2"	2-11/16"	ID-3/4-30-W	20644	ID-3/4-45-W	20704
7/8"	1/2"	2-13/16"	ID-7/8-30-W	20649	ID-7/8-45-W	20709
1"	1/2"	2-13/16"	ID-1-30-W	20650	ID-1-45-W	20710



Multi-Flute Countersinks

Severance Inside Chamfering Mills can be depended upon to produce smooth, burrless, chamfers on most machinable materials and are suitable for fairly heavy chamfering. For still heavier chamfering, consider Severance's Chatterless™ countersinks.

High Speed Steel

30° C/L (60° Included) Solid

Head Dia.	Nose Point or Flat Dia.	Overall Length	Severance Tool Name	EDP Order Number
1/4"	P	2-1/4"	IC-1/4-30	20470
5/16"	1/32"	2-1/4"	IC-5/16-30	20471
3/8"	P	2-1/4"	IC-3/8-30	20472
1/2"	9/64"	2-1/4"	ICS-1/2-30	20473
1/2"	P	2-1/4"	ICL-1/2-30	20474
5/8"	13/64"	2-1/4"	ICS-5/8-30	20475

High Speed Steel

45° C/L (90° Included) Solid

Head Dia.	Nose Point or Flat Dia.	Overall Length	Severance Tool Name	EDP Order Number
1/4"	P	2-1/4"	IC-1/4-45	20505
5/16"	1/16"	2-1/4"	IC-5/16-45	20506
3/8"	P	2-1/4"	IC-3/8-45	20507
1/2"	1/8"	2-1/4"	ICS-1/2-45	20508
1/2"	P	2-1/4"	ICL-1/2-45	20509
5/8"	1/8"	2-1/4"	ICS-5/8-45	20510

Miniature Multi-Flute Countersinks

3/32" Shank Diameter – 1-5/8"

Used on small hole and parts to chamfer or break the edge. May be resharpened many times. 3/32" shanks 25° C/L angle.

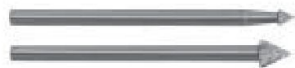

Head Dia.	Flute Length	Severance Tool Name	EDP Order Number
-----------	--------------	---------------------	------------------

Cone, Pointed Nose, 25° C/L Angle

1/16"	.081"	LM2-062	22626
3/32"	.122"	LM2-093	22627
1/8"	.162"	LM2-125	22628
3/16"	.244"	LM2-187	22629
1/4"	.325"	LM2-250	22630
5/16"	.407"	LM2-312	22631

Severance Tool Industries, Inc.

Manufactures Code 662018

Website: www.severancetool.com



Phone: 989-777-5500 Fax: 989-777-0602

E-Mail: severancetool@sbcglobal.net

Severance Tool Industries Inc. • POB 1866 • Saginaw, MI 48605

Multi-Flute Countersinks Continued...

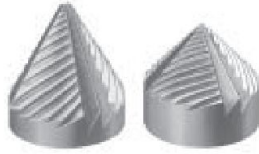

Tools are furnished without shanks.
See pages 78-80 for available shank styles and sizes.

High Speed Steel
30° C/L (60° Included) Threaded

Head Dia.	Nose Point or Flat Dia.	Overall Length	Thread Size	Severance Tool Name	EDP Order Number
5/8"	3/64"	7/8"	1/4"-28	IC-5/8-30	20476
3/4"	1/32"	1"	5/16"-24	IC-3/4-30	20477
7/8"	5/32"	1"	3/8"-24	IC-7/8-30	20478
1"	9/32"	1-1/8"	3/8"-24	ICS-1-30	20479
1"	1/8"	1-1/8"	3/8"-24	ICL-1-30	20480
1-1/8"	1/8"	1-1/8"	3/8"-24	IC-1-1/8-30	20481
1-1/4"	17/32"	1"	3/8"-24	ICS-1-1/4-30	20482
1-1/4"	3/32"	1-1/4"	3/8"-24	ICL-1-1/4-30	20483
1-1/2"	31/64"	1-1/8"	1/2"-20	ICS-1-1/2-30	20484
1-1/2"	13/64"	1-1/2"	1/2"-20	ICL-1-1/2-30	20485
1-3/4"	3/4"	1-1/4"	1/2"-20	ICS-1-3/4-30	20486
1-3/4"	5/16"	1-1/2"	1/2"-20	ICL-1-3/4-30	20487
2"	63/64"	1-1/4"	5/8"-18	ICS-2-30	20488
2"	27/32"	1-1/4"	5/8"-18	ICL-2-30	20489
2-1/4"	1-3/32"	1-3/8"	3/4"-16	ICS-2-1/4-30	20490
2-1/4"	33/64"	1-7/8"	3/4"-16	ICL-2-1/4-30	20491
2-1/2"	1-31/64"	1-1/4"	3/4"-16	ICS-2-1/2-30	20492
2-1/2"	29/32"	1-3/4"	3/4"-16	ICL-2-1/2-30	20493
3"	1-63/64"	1-1/4"	1"-14	IC-3-30	20494

High Speed Steel
45° C/L (90° Included) Threaded

Head Dia.	Nose Point or Flat Dia.	Overall Length	Thread Size	Severance Tool Name	EDP Order Number
5/8"	1/8"	11/16"	1/4"-28	IC-5/8-45	20511
3/4"	P	13/16"	5/16"-24	IC-3/4-45	20512
7/8"	5/32"	1"	3/8"-24	IC-7/8-45	20513
1"	1/4"	7/8"	3/8"-24	ICS-1-45	20514
1"	P	7/8"	3/8"-24	ICL-1-45	20515
1-1/4"	3/8"	3/4"	3/8"-24	ICS-1-1/4-45	20516
1-1/4"	P	1"	3/8"-24	ICL-1-1/4-45	20517
1-1/2"	1/2"	7/8"	1/2"-20	ICS-1-1/2-45	20518
1-1/2"	1/4"	1-1/16"	1/2"-20	ICL-1-1/2-45	20519
1-3/4"	5/8"	7/8"	1/2"-20	IC-1-3/4-45	20520
2"	1"	1"	5/8"-18	ICS-2-45	20521
2"	1/4"	1-1/2"	5/8"-18	ICL-2-45	20522
2-1/4"	1"	1"	5/8"-18	ICS-2-1/4-45	20523
2-1/4"	1/4"	1-3/8"	5/8"-18	ICL-2-1/4-45	20524
2-1/2"	3/4"	1-3/8"	3/4"-16	ICS-2-1/2-45	20525
2-1/2"	1/4"	1-5/8"	3/4"-16	ICL-2-1/2-45	20526
3"	3/4"	1-3/4"	1"-14	ICS-3-45	20527
3"	1/4"	1-7/8"	1"-14	ICL-3-45	20528



3N1® Drill Point Double Ended Countersinks

We have developed a unique tool, which combines the functions of a drill point, countersink, and edge chamfer. One double ended countersink is less costly than two single ended tools.

High Speed Steel

Head Dia.	Overall Length	Drill Point Dia.	Centerline Angle		30°		41°		45°		50°		55°		60°	
			Included Angle		60°		82°		90°		100°		110°		120°	
			Severance Name	Order Number	Order Number	Order Number	Order Number	Order Number	Order Number	Order Number						
1/8"	1-1/2"	.047"	3N1-1/8-DE	01585	01595	01605	01615	01625	01635							
3/16"	1-7/8"	.078"	3N1-3/16-DE	01586	01596	01606	01616	01626	01636							
1/4"	2"	.109"	3N1-1/4-DE	01587	01597	01607	01617	01627	01637							
5/16"	2-1/8"	.125"	3N1-5/16-DE	01588	01598	01608	01618	01628	01638							
3/8"	2-1/2"	.141"	3N1-3/8-DE	01589	01599	01609	01619	01629	01639							
1/2"	3"	.219"	3N1-1/2-DE	01590	01600	01610	01620	01630	01640							
5/8"	3-1/4"	.25"	3N1-5/8-DE	01591	01601	01611	01621	01631	01641							
3/4"	3-1/2"	.313"	3N1-3/4-DE	01592	01602	01612	01622	01632	01642							

Carbide

Head Dia.	Overall Length	Drill Point Dia.	Centerline Angle		30°		41°		45°		50°		55°		60°	
			Included Angle		60°		82°		90°		100°		110°		120°	
			Severance Name	Order Number	Order Number	Order Number	Order Number	Order Number	Order Number	Order Number						
1/8"	1-1/2"	.047"	3N1-1/8-W-DE	01650	01670	01680	01690	01700	01710							
3/16"	2"	.078"	3N1-3/16-W-DE	01651	01671	01681	01691	01701	01711							
1/4"	2"	.109"	3N1-1/4-W-DE	01652	01672	01682	01692	01702	01712							
5/16"	2-1/8"	.125"	3N1-5/16-W-DE	01653	01673	01683	01693	01703	01713							
3/8"	2-1/2"	.141"	3N1-3/8-W-DE	01654	01674	01684	01694	01704	01714							
1/2"	3"	.219"	3N1-1/2-W-DE	01655	01675	01685	01695	01705	01715							
5/8"	3-1/4"	.25"	3N1-5/8-W-DE	01656	01676	01686	01696	01706	01716							
3/4"	3-1/2"	.313"	3N1-3/4-W-DE	01657	01677	01687	01697	01707	01717							



Phone: 989-777-5500 Fax: 989-777-0602

E-Mail: severancetool@sbcglobal.net

Severance Tool Industries Inc. • POB 1866 • Saginaw, MI 48605

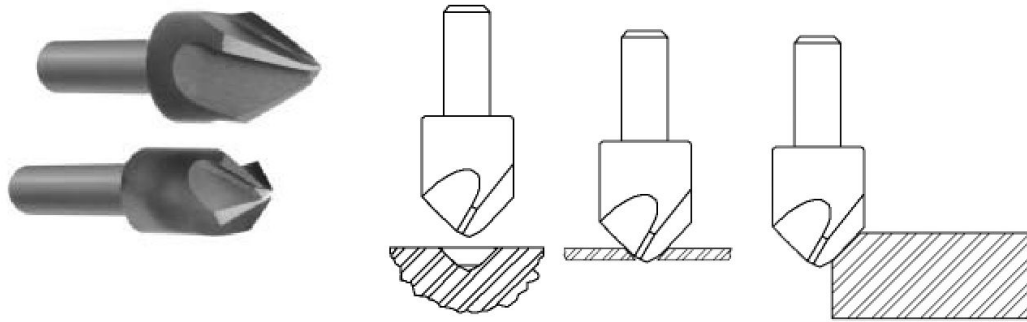

3N1® Drill Point Countersinks

We have developed a unique tool, which combines the functions of a **drill point** and **countersink** and **edge chamfer**. A conventional thin-web drill point is blended into two flutes of a four-flute chatter-free™ countersink ... to perform two or all three of the steps in a spot-drill-countersink and edge chamfer operations. Save steps, setup, production time, and lower scrap rates with a Severance 3N1® spotting tool. Specifically designed to give a true start spot and an accurate countersink chamfer on your part. See 3N1® Double Ended Countersinks on page 57.

High Speed Steel

Head Dia.	Shank Dia.	Overall Length	Shank Length	Centerline Angle		30°		41°		45°		50°		55°		60°	
				Included Angle		60°		82°		90°		100°		110°		120°	
				Severance Name	Order Number	Order Number	Order Number	Order Number	Order Number	Order Number	Order Number						
1/8"	1/8"	1-5/8"	1-5/8"	3N1-1/8	01473	01488	01503	01518	01533	01548							
3/16"	3/16"	1-1/2"	1-1/2"	3N1-3/16	01474	01489	01504	01519	01534	01549							
1/4"	3/16"	1-1/2"	3/4"	3N1-1/4	01470	01485	01500	01515	01530	01545							
1/4"	1/4"	2"	1-3/4"	3N1-1/4-1/4	01464	01465	01466	01467	01468	01469							
5/16"	1/4"	1-3/4"	7/8"	3N1-5/16	01475	01490	01505	01520	01535	01550							
3/8"	1/4"	1-3/4"	7/8"	3N1-3/8	01471	01486	01501	01516	01531	01546							
1/2"	3/8"	2-1/8"	1-1/8"	3N1-1/2	01472	01487	01502	01517	01532	01547							
5/8"	3/8"	2-3/8"	1-1/8"	3N1-5/8	01476	01491	01506	01521	01536	01551							
3/4"	1/2"	2-11/16"	1-5/16"	3N1-3/4	01477	01492	01507	01522	01537	01552							
7/8"	1/2"	2-13/16"	1-5/16"	3N1-7/8	01478	01493	01508	01523	01538	01553							
1"	1/2"	2-13/16"	1-5/16"	3N1-1	01479	01494	01509	01524	01539	01554							

Carbide

Head Dia.	Shank Dia.	Overall Length	Shank Length	Centerline Angle		30°		41°		45°		50°		55°		60°	
				Included Angle		60°		82°		90°		100°		110°		120°	
				Severance Name	Order Number	Order Number	Order Number	Order Number	Order Number	Order Number	Order Number						
1/8"	1/8"	1-1/2"	1-1/2"	3N1-1/8-W	01903	01923	01943	01963	01983	02003							
3/16"	3/16"	1-1/2"	1-1/2"	3N1-3/16-W	01904	01924	01944	01964	01984	02004							
1/4"	3/16"	1-1/2"	1-3/16"	3N1-1/4-W	01905	01925	01945	01965	01985	02005							
1/4"	1/4"	2"	2"	3N1-1/4-W-1/4	01906	01926	01946	01966	01986	02006							
5/16"	1/4"	2-1/4"	1-3/4"	3N1-5/16-W	01907	01927	01947	01967	01987	02007							
3/8"	1/4"	2-1/4"	1-3/4"	3N1-3/8-W	01908	01928	01948	01968	01988	02008							
1/2"	3/8"	2-1/2"	2"	3N1-1/2-W	01909	01929	01949	01969	01989	02009							
5/8"	3/8"	2-5/8"	2"	3N1-5/8-W	01910	01930	01950	01970	01990	02010							
3/4"	1/2"	2-3/4"	2"	3N1-3/4-W	01911	01931	01951	01971	01991	02011							
7/8"	1/2"	2-7/8"	2"	3N1-7/8-W	01912	01932	01952	01972	01992	02012							
1"	1/2"	3"	2"	3N1-1 -W	01913	01933	01953	01973	01993	02013							

Severance Tool Industries, Inc.
 Manufactures Code 662018
 Website: www.severancetool.com



Phone: 989-777-5500 Fax: 989-777-0602

E-Mail: severancetool@sbcglobal.net

Severance Tool Industries Inc. • POB 1866 • Saginaw, MI 48605

3N1-QC™ Quick Change Countersink System

Patent Pending

Benefits of a 3N1-QC™ Drill Point Countersink

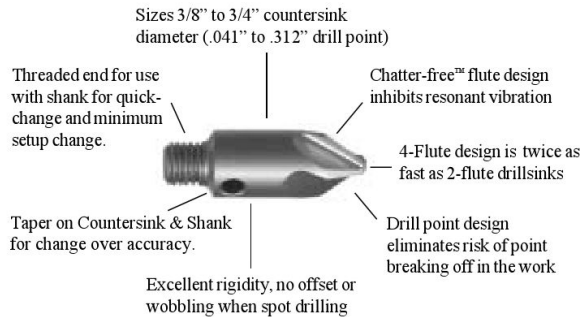

Save steps, setup, production time, and lower scrap rates with a Severance 3N1-QC™ Spotting tool. Specifically designed to give a true start spot and an accurate countersink chamfer on your part.

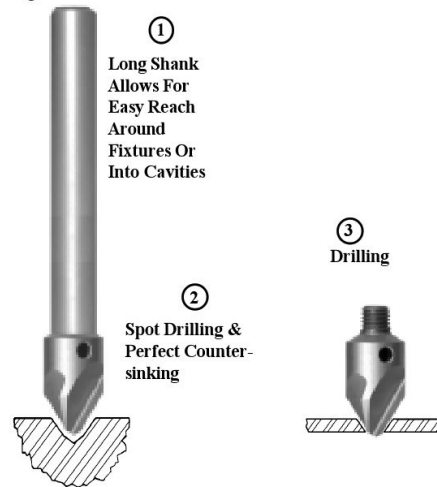

Quick Change Countersink System

Severance Tool introduces the new 3N1-QC™ Quick Change Countersink System. Featuring standard shanks in 4", 6", and 8" over all lengths, this system is designed to allow quick change of the countersink head for fast tool changes while maintaining dimensional integrity. The quick-change head has a positive lock up on a 60° seat angle and with a threaded lock, tool changes are fast and simple. All 3N1-QC™ threaded countersinks are factory resharpenable.

How Does a 3N1-QC™ Work?

Severance has developed a unique tool, which combines the functions of a drill point starter and true countersink in a quick-change tool. A conventional thin-web drill point is blended into two flutes of a four-flute chatter-free™ countersink ... to perform two or all three of the steps in a spot-drill-countersink and edge chamfer operations. Once you have established a tool in a chuck, you can leave the shank in place and quickly change out the dull 3N1® head with a sharp 3N1®, fast change over. On thin material, such as above, drilling could be optional.

High Speed Steel

Head Dia.	Overall Length	Drill Point Dia.	Thread Size	Centerline Angle									
				30°		41°		50°		60°			
				Included Angle	Severance Name	Included Angle	Severance Name	Included Angle	Severance Name	Included Angle	Severance Name		
3/8"	1-5/32"	.141"	1/4"-28	60°	3N1-QC-3/8	82°	3N1-QC-7/16	90°	3N1-QC-1/2	100°	3N1-QC-5/8	120°	3N1-QC-3/4
7/16"	1-5/32"	.188"	1/4"-28	Order Number	01800	Order Number	01810	Order Number	01820	Order Number	01830	Order Number	01840
1/2"	1-5/32"	.219"	1/4"-28	Order Number	01801	Order Number	01811	Order Number	01821	Order Number	01831	Order Number	01841
5/8"	1-5/32"	.25"	1/4"-28	Order Number	01802	Order Number	01812	Order Number	01822	Order Number	01832	Order Number	01842
3/4"	1-13/16"	.313"	3/8"-24	Order Number	01803	Order Number	01813	Order Number	01823	Order Number	01833	Order Number	01843
				Order Number	01804	Order Number	01814	Order Number	01824	Order Number	01834	Order Number	01844

Note: When Ordering 3N1-QC™ Make Sure To Specify Angle, Example (3N1-QC-3/8-45)

Shanks for 3N1-QC™ Cutters

Thread Size	Shank		Overall Length	Shoulder Dia.	Severance Shank Name	EDP Order Number
	Frac.	Dec.				
1/4"-28	1/4"	.250	4"	7/16"	FM-2 Shank	34235
1/4"-28	1/2"	.500	6"	1/2"	FM-2x6 Shank	34239
1/4"-28	1/2"	.500	8"	1/2"	FM-2x8 Shank	34240
3/8"-24	1/4"	.250	4"	9/16"	FM-3 Shank	34236
3/8"-24	5/8"	.625	6"	5/8"	FM-3x6 Shank	34241
3/8"-24	5/8"	.625	8"	5/8"	FM-3x8 Shank	34242

See pages 78-80 for other available shank styles and sizes.



Phone: 989-777-5500 Fax: 989-777-0602

E-Mail: severancetool@sbcglobal.net

Severance Tool Industries Inc. • POB 1866 • Saginaw, MI 48605

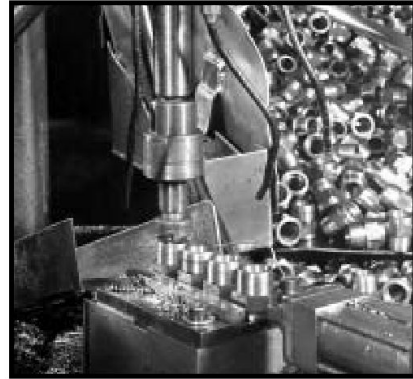

4-Flute Chatter-Free® Econo-Sinks®

Severance Econo-Sinks® features a Chatter-Free®, four-flute design. Econo-Sinks® are designed with four staggered cutting teeth arranged to insure free chip flow and rapid Chatter-Free® cutting. You will find the Econo-Sinks® give you better finishes, higher production, and more economic value than a single flute tool. Ideal on a wide range of materials including non-ferrous and other stringy materials and cast iron. Other diameters and angles available upon request.

High Speed Steel

Head Dia.	Shank Dia.	Overall Length	Shank Length	Centerline Angle		30°		41°		45°		50°		55°		60°	
				Included Angle		60°		82°		90°		100°		110°		120°	
				Severance Name	Order Number	Order Number	Order Number	Order Number	Order Number	Order Number	Order Number						
1/8"	1/8"	1-5/8"	1-5/8"	ES-1/8	00970	00991	01012	01033	01054	01075							
3/16"	3/16"	1-1/2"	1-1/2"	ES-3/16	00971	00992	01013	01034	01055	01076							
1/4"	3/16"	1-1/2"	3/4"	ES-1/4	00972	00993	01014	01035	01056	01077							
5/16"	1/4"	1-3/4"	7/8"	ES-5/16	00973	00994	01015	01036	01057	01078							
3/8"	1/4"	1-3/4"	7/8"	ES-3/8	00974	00995	01016	01037	01058	01079							
1/2"	3/8"	2-1/8"	1-1/8"	ES-1/2	00976	00997	01018	01039	01060	01081							
1/2"	1/4"	2-1/8"	1-1/8"	ES-1/2-1/4	00977	00998	01019	01040	01061	01082							
5/8"	3/8"	2-3/8"	1-1/8"	ES-5/8	00978	00999	01020	01041	01062	01083							
5/8"	1/4"	2-3/8"	1-1/8"	ES-5/8-1/4	00979	01000	01021	01042	01063	01084							
3/4"	1/2"	2-11/16"	1-5/16"	ES-3/4	00980	01001	01022	01043	01064	01085							
7/8"	1/2"	2-13/16"	1-5/16"	ES-7/8	00982	01003	01024	01045	01066	01087							
1"	1/2"	2-13/16"	1-5/16"	ES-1	00983	01004	01025	01046	01067	01088							
1-1/4"	3/4"	3-3/8"	1-5/8"	ES-1-1/4	00984	01005	01026	01047	01068	01089							
1-1/2"	3/4"	3-1/2"	1-5/8"	ES-1-1/2	00985	01006	01027	01048	01069	01090							
1-3/4"	1"	4-1/4"	2-1/8"	ES-1-3/4	00987	01008	01029	01050	01071	01092							
2"	1"	4-3/8"	2-1/8"	ES-2	00988	01009	01030	01051	01072	01093							
2-1/2"	1"	4-3/4"	2-1/8"	ES-2-1/2	00989	01010	01031	01052	01073	01094							
3"	1"	5"	2-1/8"	ES-3	00990	01011	01032	01053	01074	01095							

Carbide

Head Dia.	Shank Dia.	Overall Length	Shank Length	Centerline Angle		30°		41°		45°		50°		55°		60°	
				Included Angle		60°		82°		90°		100°		110°		120°	
				Severance Name	Order Number	Order Number	Order Number	Order Number	Order Number	Order Number	Order Number						
1/8"	1/8"	1-1/2"	1-1/2"	ES-1/8-W	01120	01135	01150	01165	01180	01195							
1/4"	3/16"	1-1/2"	1-3/16"	ES-1/4-W	01121	01136	01151	01166	01181	01196							
3/8"	1/4"	2-1/4"	1-3/4"	ES-3/8-W	01122	01137	01152	01167	01182	01197							
1/2"	3/8"	2-1/4"	1-3/4"	ES-1/2-W	01125	01140	01155	01170	01185	01200							
5/8"	3/8"	2-5/8"	2"	ES-5/8-W	01126	01141	01156	01171	01186	01201							
3/4"	1/2"	2-3/4"	2"	ES-3/4-W	01127	01142	01157	01172	01187	01202							
1"	1/2"	3"	2"	ES-1-W	01128	01143	01158	01173	01188	01203							

Severance Tool Industries, Inc.
 Manufactures Code 662018
 Website: www.severancetool.com



Phone: 989-777-5500 Fax: 989-777-0602

E-Mail: severancetool@sbcglobal.net

Severance Tool Industries Inc. • POB 1866 • Saginaw, MI 48605



4-Flute Chatter-Free® Double Ended Econo-Sinks®

Severance 4-Flute chatter-free™ countersinks feature a 2+2 staggered cutting flute design. This tool provides lots of chip clearance and is ideal for non-ferrous materials including aluminum and plastics.

High Speed Steel

Head Dia.	Overall Length	Centerline Angle		30°	41°	45°	50°	55°	60°
		Included Angle		60°	82°	90°	100°	110°	120°
		Severance Name	Order Number	Order Number	Order Number	Order Number	Order Number	Order Number	
1/8"	1-1/2"	ES-1/8-DE	01204	01212	01220	01228	01236	01244	
3/16"	1-7/8"	ES-3/16-DE	01205	01213	01221	01229	01237	01245	
1/4"	2"	ES-1/4-DE	01206	01214	01222	01230	01238	01246	
5/16"	2-1/8"	ES-5/16-DE	01207	01215	01223	01231	01239	01247	
3/8"	2-1/2"	ES-3/8-DE	01208	01216	01224	01232	01240	01248	
1/2"	3"	ES-1/2-DE	01209	01217	01225	01233	01241	01249	
5/8"	3-1/4"	ES-5/8-DE	01210	01218	01226	01234	01242	01250	
3/4"	3-1/2"	ES-3/4-DE	01211	01219	01227	01235	01243	01251	

Carbide

Head Dia.	Overall Length	Centerline Angle		30°	41°	45°	50°	55°	60°
		Included Angle		60°	82°	90°	100°	110°	120°
		Severance Name	Order Number	Order Number	Order Number	Order Number	Order Number	Order Number	
1/8"	1-1/2"	ES-1/8-W-DE	01252	01260	01268	01276	01284	01292	
3/16"	2"	ES-3/16-W-DE	01253	01261	01269	01277	01285	01293	
1/4"	2"	ES-1/4-W-DE	01254	01262	01270	01278	01286	01294	
5/16"	2-1/8"	ES-5/16-W-DE	01255	01263	01271	01279	01287	01295	
3/8"	2-1/2"	ES-3/8-W-DE	01256	01264	01272	01280	01288	01296	
1/2"	3"	ES-1/2-W-DE	01257	01265	01273	01281	01289	01297	
5/8"	3-1/4"	ES-5/8-W-DE	01258	01266	01274	01282	01290	01298	
3/4"	3-1/2"	ES-3/4-W-DE	01259	01267	01275	01283	01291	01299	



Single Flute Double Ended Countersinks

Severance Single Flute Countersinks features our positive shear cutting edge. Single flutes are ideal for non-rigid machining applications, or for machines with less than precision spindles.

High Speed Steel

Head Dia.	Overall Length	Centerline Angle		30°	41°	45°	50°	55°	60°
		Included Angle		60°	82°	90°	100°	110°	120°
		Severance Name	Order Number	Order Number	Order Number	Order Number	Order Number	Order Number	
1/8"	1-1/2"	1/8-SF-DE	00536	00544	00552	00560	00568	00576	
3/16"	1-7/8"	3/16-SF-DE	00537	00545	00553	00561	00569	00577	
1/4"	2"	1/4-SF-DE	00538	00546	00554	00562	00570	00578	
5/16"	2-1/8"	5/16-SF-DE	00539	00547	00555	00563	00571	00579	
3/8"	2-1/2"	3/8-SF-DE	00540	00548	00556	00564	00572	00580	
1/2"	3"	1/2-SF-DE	00541	00549	00557	00565	00573	00581	
5/8"	3-1/4"	5/8-SF-DE	00542	00550	00558	00566	00574	00582	
3/4"	3-1/2"	3/4-SF-DE	00543	00551	00559	00567	00575	00583	

Carbide

Head Dia.	Overall Length	Centerline Angle		30°	41°	45°	50°	55°	60°
		Included Angle		60°	82°	90°	100°	110°	120°
		Severance Name	Order Number	Order Number	Order Number	Order Number	Order Number	Order Number	
1/8"	1-1/2"	1/8-SF-W-DE	00600	00609	00617	00625	00633	00641	
3/16"	2"	3/16-SF-W-DE	00601	00610	00618	00626	00634	00642	
1/4"	2"	1/4-SF-W-DE	00602	00611	00619	00627	00635	00643	
5/16"	2-1/8"	5/16-SF-W-DE	00603	00612	00620	00628	00636	00644	
3/8"	2-1/2"	3/8-SF-W-DE	00604	00613	00621	00629	00637	00645	
1/2"	3"	1/2-SF-W-DE	00605	00614	00622	00630	00638	00646	
5/8"	3-1/4"	5/8-SF-W-DE	00606	00615	00623	00631	00639	00647	
3/4"	3-1/2"	3/4-SF-W-DE	00607	00616	00624	00632	00640	00648	



Phone: 989-777-5500 Fax: 989-777-0602
 E-Mail: severancetool@sbcglobal.net

Severance Tool Industries Inc. • POB 1866 • Saginaw, MI 48605



Single Flute Countersinks

Single flute countersinks produce excellent results for light burr-free countersinking operations, are excellent at small hole chamfers, can operate at slightly higher RPM's, and may be reground many times. Other Diameters and angles can be provided as specials. Countersinks larger than 1" are not pointed, but have flat ends.

High Speed Steel

Head Dia.	Shank Dia.	Overall Length	Shank Length	Centerline Angle		30°	41°	45°	50°	55°	60°
				Included Angle		60°	82°	90°	100°	110°	120°
				Severance Name	Order Number	Order Number	Order Number	Order Number	Order Number		
1/8"	1/8"	1-5/8"	1-5/8"	1/8-SF	00270	00288	00306	00324	00342	00360	
3/16"	3/16"	1-1/2"	1-1/2"	3/16-SF	00271	00289	00307	00325	00343	00361	
1/4"	3/16"	1-1/2"	3/4"	1/4-SF	00272	00290	00308	00326	00344	00362	
5/16"	1/4"	1-3/4"	7/8"	5/16-SF	00273	00291	00309	00327	00345	00363	
3/8"	1/4"	1-3/4"	7/8"	3/8-SF	00274	00292	00310	00328	00346	00364	
1/2"	3/8"	2-1/8"	1-1/8"	1/2-SF	00275	00293	00311	00329	00347	00365	
1/2"	1/4"	2-1/8"	1-1/8"	1/2-SF-1/4	00276	00294	00312	00330	00348	00366	
5/8"	3/8"	2-3/8"	1-1/8"	5/8-SF	00277	00295	00313	00331	00349	00367	
5/8"	1/4"	2-3/8"	1-1/8"	5/8-SF-1/4	00278	00296	00314	00332	00350	00368	
3/4"	1/2"	2-11/16"	1-5/16"	3/4-SF	00279	00297	00315	00333	00351	00369	
7/8"	1/2"	2-13/16"	1-5/16"	7/8-SF	00280	00298	00316	00334	00352	00370	
1"	1/2"	2-13/16"	1-5/16"	1-SF	00281	00299	00317	00335	00353	00371	
1-1/4"	3/4"	3-3/8"	1-5/8"	1-1/4-SF	00282	00300	00318	00336	00354	00372	
1-1/2"	3/4"	3-1/2"	1-5/8"	1-1/2-SF	00283	00301	00319	00337	00355	00373	
1-3/4"	1"	4-1/4"	2-1/8"	1-3/4-SF	00284	00302	00320	00338	00356	00374	
2"	1"	4-3/8"	2-1/8"	2-SF	00285	00303	00321	00339	00357	00375	
2-1/2"	1"	4-3/4"	2-1/8"	2-1/2-SF	00286	00304	00322	00340	00358	00376	
3"	1"	5"	2-1/8"	3-SF	00287	00305	00323	00341	00359	00377	

Carbide

Head Dia.	Shank Dia.	Overall Length	Shank Length	Centerline Angle		30°	41°	45°	50°	55°	60°
				Included Angle		60°	82°	90°	100°	110°	120°
				Severance Name	Order Number	Order Number	Order Number	Order Number	Order Number		
1/8"	1/8"	1-1/2"	1-1/2"	1/8-SF-W	00420	00440	00460	00480	00500	00520	
3/16"	3/16"	1-1/2"	1-1/2"	3/16-SF-W	00421	00441	00461	00481	00501	00521	
1/4"	3/16"	1-1/2"	1-3/16"	1/4-SF-W	00422	00442	00462	00482	00502	00522	
5/16"	1/4"	2-1/4"	1-3/4"	5/16-SF-W	00423	00443	00463	00483	00503	00523	
3/8"	1/4"	2-1/4"	1-3/4"	3/8-SF-W	00424	00444	00464	00484	00504	00524	
1/2"	3/8"	2-1/2"	2"	1/2-SF-W	00425	00445	00465	00485	00505	00525	
1/2"	1/4"	2-1/4"	1-3/4"	1/2-SF-W-1/4	00426	00446	00466	00486	00506	00526	
5/8"	3/8"	2-5/8"	2"	5/8-SF-W	00427	00447	00467	00487	00507	00527	
5/8"	1/4"	2-3/8"	1-3/4"	5/8-SF-W-1/4	00428	00448	00468	00488	00508	00528	
3/4"	1/2"	2-3/4"	2"	3/4-SF-W	00429	00449	00469	00489	00509	00529	
7/8"	1/2"	2-7/8"	2"	7/8-SF-W	00430	00450	00470	00490	00510	00530	
1"	1/2"	3"	2"	1-SF-W	00431	00451	00471	00491	00511	00531	
1-1/4"	3/4"	3-3/8"	1-5/8"	1-1/4-SF-W	00432	00452	00472	00492	00512	00532	
1-1/2"	3/4"	3-1/2"	1-5/8"	1-1/2-SF-W	00433	00453	00473	00493	00513	00533	
1-3/4"	1"	4-1/4"	2-1/8"	1-3/4-SF-W	00434	00454	00474	00494	00514	00534	
2"	1"	4-3/8"	2-1/8"	2-SF-W	00435	00455	00475	00495	00515	00535	

Severance Tool Industries, Inc.
 Manufactures Code 662018
 Website: www.severancetool.com



Phone: 989-777-5500 Fax: 989-777-0602

E-Mail: severancetool@sbcglobal.net

Severance Tool Industries Inc. • POB 1866 • Saginaw, MI 48605



High Speed Steel

AC-Adjustable Countersinks

Severance AC Countersinks are designed out of high speed steel as an economical means of combining drilling and countersinking into a continuous operation. They are well adapted to a wide range of applications, and can be used for countersinking wood or light metals, such as mild steel, magnesium, brass and die cast, and for some plastics.

They can be used with any standard twist drill in sizes as indicated, so they need not be discarded if the drill breaks or is used up. They can be positioned at any point along the fluted section of a drill and work best if adjusted to start countersinking when the drilling has been completed.

The cutting teeth are arranged to give a shearing cut, to produce a seat free from chatter and to avoid corkscrew jamming.

These Tools can be factory resharpened many times for cost efficiency. See pages 89-90 for more details.

Drill not included.

C'Sink Body Dia.	Drill Size	Overall Length	Centerline Angle		
			Included Angle		45°
			Severance Name	Order Number	Order Number
			41°	82°	90°
3/8"	1/8" (.1250)	1"	6-AC-2	03572	03622
3/8"	29 (.1360)	1"	6-AC-29	03573	03623
3/8"	28 (.1405)	1"	6-AC-28	03574	03624
3/8"	25 (.1495)	1"	6-AC-25	03575	03625
3/8"	21 (.1590)	1"	6-AC-21	03576	03626
3/8"	19 (.1660)	1"	6-AC-19	03577	03627
1/2"	16 (.1770)	1-1/8"	8-AC-16	03579	03629
1/2"	14 (.1820)	1-1/8"	8-AC-14	03580	03630
1/2"	3/16" (.1875)	1-1/8"	8-AC-3/16	03578	03628
1/2"	10 (.1935)	1-1/8"	8-AC-10	03582	03632
1/2"	7 (.2010)	1-1/8"	8-AC-7	03583	03633
1/2"	7/32" (.2188)	1-1/8"	8-AC-7/32	03581	03631
5/8"	3 (.2130)	1-1/8"	10-AC-3	03586	03636
5/8"	7/32" (.2188)	1-1/8"	10-AC-7/32	03584	03634
5/8"	2 (.2210)	1-1/8"	10-AC-2	03587	03637
5/8"	D (.2460)	1-1/8"	10-AC-D	03590	03640
5/8"	1/4" (.2500)	1-1/8"	10-AC-4	03585	03635
5/8"	F (.2570)	1-1/8"	10-AC-F	03603	03604
5/8"	I (.2720)	1-1/8"	10-AC-I	03591	03641
5/8"	9/32" (.2813)	1-1/8"	10-AC-9/32	03588	03638
5/8"	5/16" (.3125)	1-1/8"	10-AC-5/16	03589	03639
7/8"	Q (.3320)	1-1/2"	14-AC-Q	03592	03642
7/8"	R (.3390)	1-1/2"	14-AC-R	03593	03643
7/8"	S (.3480)	1-1/2"	14-AC-S	03594	03644
7/8"	U (.3680)	1-1/2"	14-AC-U	03596	03646
7/8"	3/8" (.3750)	1-1/2"	14-AC-3/8	03595	03645
7/8"	25/64" (.3906)	1-1/2"	14-AC-25/64	03597	03647
1-1/8"	27/64" (.4219)	1-3/4"	18-AC-27/64	03598	03648
1-1/8"	7/16" (.4375)	1-3/4"	18-AC-7/16	03599	03649
1-1/8"	29/64" (.4531)	1-3/4"	18-AC-29/64	03600	03650
1-1/8"	31/64" (.4844)	1-3/4"	18-AC-31/64	03602	03652
1-1/8"	1/2" (.5000)	1-3/4"	18-AC-1/2	03601	03651

Special Adjustable Countersinks

Special diameters, drill sizes, flute configurations, and angles are available as specials. This Adjustable countersink is designed for non-ferrous materials such as aluminum and magnesium.



REF. # 55381



Phone: 989-777-5500 Fax: 989-777-0602

E-Mail: severancetool@sbcglobal.net

Severance Tool Industries Inc. • POB 1866 • Saginaw, MI 48605

Micrometer Stop-Countersink Units

The Micrometer Micro Stop-Countersink Unit was invented and patented (USP 3028774) by Severance Tool for the aircraft industry to allow precise depth control countersinking and deburring. These units ensure perpendicular alignment with the workpiece and easy to adjust exact depth control in increments of .001". They feature hardened and ground spindles supported by ball bearings, bronze sleeves, or needle bearings, and thrust bearings, and a lock nut to maintain "preset" depth dimensions. Overhang is at a minimum making it possible to work in close quarters.

These units are still widely used in Aircraft manufacturing and maintenance, in sheet metal part production areas, and have found wide use in Transportation, electronic, medical, defense, and telecommunications where precise depth control countersinking is required. Used in hand drills, drill presses, mills, lathes, etc. Bases can be modified for special applications or contours. See "NEW" high speed roller bearing units RSC-24 & RSC-36.



Recommended Maximum Cutter	Unit Shank Dia.	Standard Outside Dia.	Overall Length Retracted	Overall Length Extended	Length of Stroke	Internal Thread	Severance Tool Name	EDP Order Number
7/16"	1/4"	7/8"	3.243"	3.544"	.180	1/4"-28	SC-14	21220
3/4"	1/4"	1-1/16"	3.265"	3.513"	.180	1/4"-28	SC-24	21221
3/4"	1/4"	1-1/16"	3.265"	3.513"	.180	1/4"-28	RSC-24	21227
3/4"	3/8"	1-1/16"	3.310"	3.521"	.180	3/8"-24	SC-36	21222
3/4"	3/8"	1-1/16"	3.310"	3.521"	.180	3/8"-24	RSC-36	21228
1-1/4"	1/2"	1-3/4"	4.270"	4.715"	.280	7/16"-20	SC-47	21223
1-1/4"	3/8"	1-3/4"	4.700"	5.185"	.280	3/8"-24	SC-57	21224



Special Override Micro-Stop Countersink Units Available by Application

Non-Marking Nylon Foot	Maximum Cutting Diameter With Foot	Part Number	EDP Number
	7/16"	SC-14-11	21245
5/8"	SC-24-11	21264	
5/8"	SC-36-11	21264	
1-1/4"	SC-47-11	21302	
1-1/4"	SC-57-11	21302	

Special units and cutters can be made to fit customers applications

A Severance Precision Stop Countersink Unit is designed for hand power-tool and drill-press use.

This unit converts your drill-press into a precision countersinking unit, giving you identical countersinks on parts of various thicknesses.

#2 Morse Taper Adapter for SC-47 Unit

Part No.	EDP No.
FM-4-MT	34238

If adapter is ordered at the same time as SC-47 UNIT, unit will be provided with a whistle notch.

Severance Tool Industries, Inc.
 Manufactures Code 662018
 Website: www.severancetool.com



Phone: 989-777-5500 Fax: 989-777-0602

E-Mail: severancetool@sbcglobal.net

Severance Tool Industries Inc. • POB 1866 • Saginaw, MI 48605

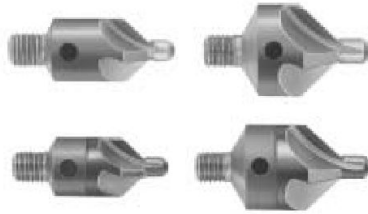

Chatter-Free® Stop-Countersinks Cutters

Also known as Aircraft style Stop-Countersinks. These tools feature our patented 4 flute Chatter-Free® flute design for smooth finishes, fast production, and quick chip removal. These precision ground tools are made from High Speed Steel or Carbide and may be factory resharpened many times for long useful tool life. Also available with special pilot sizes, angles, forms, and no pilots upon request.

High Speed Steel

Head Dia.	Pilot Dia.	Thread Dia.	Overall Length	Centerline Angle									
				39°		41°		45°		50°		60°	
				Included Angle		78°		82°		90°		100°	
Severance Name	Order Number	Order Number	Order Number	Order Number	Order Number	Order Number	Order Number	Order Number	Order Number	Order Number	Order Number		
3/8"	3/32 (.0938)	1/4"-28	1-5/32"	SC-6	15340	15485	15629	15774	15919				
3/8"	#40 (.0980)	1/4"-28	1-5/32"	SC-6	15341	15486	15630	15775	15920				
3/8"	1/8 (.1250)	1/4"-28	1-5/32"	SC-6	15342	15487	15631	15776	15921				
3/8"	#30 (.1285)	1/4"-28	1-5/32"	SC-6	15343	15488	15632	15777	15922				
3/8"	5/32 (.1562)	1/4"-28	1-5/32"	SC-6	15345	15489	15634	15779	15924				
3/8"	#21 (.1590)	1/4"-28	1-5/32"	SC-6	15346	15490	15635	15780	15925				
3/8"	3/16 (.1875)	1/4"-28	1-5/32"	SC-6	15347	15491	15636	15781	15926				
3/8"	#10 (.1935)	1/4"-28	1-5/32"	SC-6	15348	15492	15637	15782	15927				
7/16"	3/32 (.0938)	1/4"-28	1-5/32"	SC-7	15350	15494	15639	15784	15929				
7/16"	#40 (.0980)	1/4"-28	1-5/32"	SC-7	15351	15495	15640	15785	15930				
7/16"	1/8 (.1250)	1/4"-28	1-5/32"	SC-7	15352	15496	15641	15786	15931				
7/16"	#30 (.1285)	1/4"-28	1-5/32"	SC-7	15353	15497	15642	15787	15932				
7/16"	5/32 (.1562)	1/4"-28	1-5/32"	SC-7	15355	15499	15644	15789	15934				
7/16"	#21 (.1590)	1/4"-28	1-5/32"	SC-7	15356	15500	15645	15790	15935				
7/16"	3/16 (.1875)	1/4"-28	1-5/32"	SC-7	15357	15501	15646	15791	15936				
7/16"	#10 (.1935)	1/4"-28	1-5/32"	SC-7	15358	15502	15647	15792	15937				
1/2"	3/32 (.0938)	1/4"-28	1-5/32"	SC-8	15360	15504	15649	15794	15939				
1/2"	#40 (.0980)	1/4"-28	1-5/32"	SC-8	15361	15505	15650	15795	15940				
1/2"	1/8 (.1250)	1/4"-28	1-5/32"	SC-8	15362	15506	15651	15796	15941				
1/2"	#30 (.1285)	1/4"-28	1-5/32"	SC-8	15363	15507	15652	15797	15942				
1/2"	5/32 (.1562)	1/4"-28	1-5/32"	SC-8	15364	15508	15653	15798	15943				
1/2"	#21 (.1590)	1/4"-28	1-5/32"	SC-8	15366	15510	15655	15800	15945				
1/2"	3/16 (.1875)	1/4"-28	1-5/32"	SC-8	15367	15511	15656	15801	15946				
1/2"	#10 (.1935)	1/4"-28	1-5/32"	SC-8	15368	15512	15657	15802	15947				
1/2"	7/32 (.2187)	1/4"-28	1-5/32"	SC-8	15369	15513	15658	15803	15948				
1/2"	1/4 (.2500)	1/4"-28	1-5/32"	SC-8	15370	15514	15659	15804	15949				
5/8"	1/8 (.1250)	1/4"-28	1-5/32"	SC-10	15372	15516	15661	15806	15951				
5/8"	#30 (.1285)	1/4"-28	1-5/32"	SC-10	15373	15517	15662	15807	15952				
5/8"	5/32 (.1562)	1/4"-28	1-5/32"	SC-10	15374	15518	15663	15808	15953				
5/8"	#21 (.1590)	1/4"-28	1-5/32"	SC-10	15375	15519	15664	15809	15954				
5/8"	3/16 (.1875)	1/4"-28	1-5/32"	SC-10	15376	15520	15665	15810	15955				
5/8"	#10 (.1935)	1/4"-28	1-5/32"	SC-10	15378	15522	15667	15812	15957				
5/8"	7/32 (.2187)	1/4"-28	1-5/32"	SC-10	15379	15523	15668	15813	15958				
5/8"	1/4 (.2500)	1/4"-28	1-5/32"	SC-10	15380	15524	15669	15814	15959				
5/8"	5/16 (.3125)	1/4"-28	1-5/32"	SC-10	15381	15525	15670	15815	15960				
5/8"	3/8 (.3750)	1/4"-28	1-5/32"	SC-10	15382	15526	15671	15816	15961				
3/4"	5/32 (.1562)	1/4"-28	1-3/16"	SC-12	15384	15528	15673	15818	15963				
3/4"	#21 (.1590)	1/4"-28	1-3/16"	SC-12	15385	15529	15674	15819	15964				
3/4"	3/16 (.1875)	1/4"-28	1-3/16"	SC-12	15386	15530	15675	15820	15965				
3/4"	#10 (.1935)	1/4"-28	1-3/16"	SC-12	15387	15531	15676	15821	15966				
3/4"	7/32 (.2187)	1/4"-28	1-3/16"	SC-12	15389	15533	15678	15823	15968				
3/4"	1/4 (.2500)	1/4"-28	1-3/16"	SC-12	15390	15534	15679	15824	15969				
3/4"	"F" (.2570)	1/4"-28	1-3/16"	SC-12	15391	15535	15680	15825	15970				
3/4"	5/16 (.3125)	1/4"-28	1-3/16"	SC-12	15392	15536	15681	15826	15971				
3/4"	3/8 (.3750)	1/4"-28	1-3/16"	SC-12	15393	15537	15682	15827	15972				
3/4"	5/32 (.1562)	3/8"-24	1-3/16"	S3-12	15395	15539	15684	15829	15974				
3/4"	#21 (.1590)	3/8"-24	1-3/16"	S3-12	15396	15540	15685	15830	15975				



Phone: 989-777-5500 Fax: 989-777-0602

E-Mail: severancetool@sbcglobal.net

Severance Tool Industries Inc. • POB 1866 • Saginaw, MI 48605

Chatter-Free™ Stop-Countersinks Cutters continued....



High Speed Steel

Head Dia.	Pilot Dia.	Thread Dia.	Overall Length	Centerline Angle		39°	41°	45°	50°	60°
				Included Angle		78°	82°	90°	100°	120°
				Severance Name	Order Number	Order Number	Order Number	Order Number	Order Number	
3/4"	3/16 (.1875)	3/8"-24	1-3/16"	S3-12	15397	15541	15686	15831	15976	
3/4"	#10 (.1935)	3/8"-24	1-3/16"	S3-12	15398	15542	15687	15832	15977	
3/4"	7/32 (.2187)	3/8"-24	1-3/16"	S3-12	15400	15544	15689	15834	15979	
3/4"	1/4 (.2500)	3/8"-24	1-3/16"	S3-12	15401	15545	15690	15835	15980	
3/4"	"F" (.2570)	3/8"-24	1-3/16"	S3-12	15402	15546	15691	15836	15981	
3/4"	5/16 (.3125)	3/8"-24	1-3/16"	S3-12	15403	15547	15692	15837	15982	
3/4"	3/8 (.3750)	3/8"-24	1-3/16"	S3-12	15404	15548	15693	15838	15983	
1-1/4"	3/16 (.1875)	7/16"-20	1-3/8"	SC-20	15406	15550	15695	15840	15985	
1-1/4"	#10 (.1935)	7/16"-20	1-3/8"	SC-20	15407	15551	15696	15841	15986	
1-1/4"	7/32 (.2187)	7/16"-20	1-3/8"	SC-20	15408	15552	15697	15842	15987	
1-1/4"	1/4 (.2500)	7/16"-20	1-3/8"	SC-20	15409	15553	15698	15843	15988	
1-1/4"	"F" (.2570)	7/16"-20	1-3/8"	SC-20	15411	15555	15700	15845	15990	
1-1/4"	5/16 (.3125)	7/16"-20	1-3/8"	SC-20	15412	15556	15701	15846	15991	
1-1/4"	3/8 (.3750)	7/16"-20	1-3/8"	SC-20	15413	15557	15702	15847	15992	
1-1/4"	1/2 (.5000)	7/16"-20	1-3/8"	SC-20	15414	15558	15703	15848	15993	



Carbide

Head Dia.	Pilot Dia.	Thread Dia.	Overall Length	Centerline Angle		39°	41°	45°	50°	60°
				Included Angle		78°	82°	90°	100°	120°
				Severance Name	Order Number	Order Number	Order Number	Order Number	Order Number	
3/8"	3/32 (.0938)	1/4"-28	1-5/32"	SC-6-W	13840	13985	14129	14274	14419	
3/8"	#40 (.0980)	1/4"-28	1-5/32"	SC-6-W	13841	13986	14130	14275	14420	
3/8"	1/8 (.1250)	1/4"-28	1-5/32"	SC-6-W	13842	13987	14131	14276	14421	
3/8"	#30 (.1285)	1/4"-28	1-5/32"	SC-6-W	13843	13988	14132	14277	14422	
3/8"	5/32 (.1562)	1/4"-28	1-5/32"	SC-6-W	13845	13989	14134	14279	14424	
3/8"	#21 (.1590)	1/4"-28	1-5/32"	SC-6-W	13846	13990	14135	14280	14425	
3/8"	3/16 (.1875)	1/4"-28	1-5/32"	SC-6-W	13847	13991	14136	14281	14426	
3/8"	#10 (.1935)	1/4"-28	1-5/32"	SC-6-W	13848	13992	14137	14282	14427	
7/16"	3/32 (.0938)	1/4"-28	1-5/32"	SC-7-W	13850	13994	14139	14284	14429	
7/16"	#40 (.0980)	1/4"-28	1-5/32"	SC-7-W	13851	13995	14140	14285	14430	
7/16"	1/8 (.1250)	1/4"-28	1-5/32"	SC-7-W	13852	13996	14141	14286	14431	
7/16"	#30 (.1285)	1/4"-28	1-5/32"	SC-7-W	13853	13997	14142	14287	14432	
7/16"	5/32 (.1562)	1/4"-28	1-5/32"	SC-7-W	13855	13999	14144	14289	14434	
7/16"	#21 (.1590)	1/4"-28	1-5/32"	SC-7-W	13856	14000	14145	14290	14435	
7/16"	3/16 (.1875)	1/4"-28	1-5/32"	SC-7-W	13857	14001	14146	14291	14436	
7/16"	#10 (.1935)	1/4"-28	1-5/32"	SC-7-W	13858	14002	14147	14292	14437	
1/2"	3/32 (.0938)	1/4"-28	1-5/32"	SC-8-W	13860	14004	14149	14294	14439	
1/2"	#40 (.0980)	1/4"-28	1-5/32"	SC-8-W	13861	14005	14150	14295	14440	
1/2"	1/8 (.1250)	1/4"-28	1-5/32"	SC-8-W	13862	14006	14151	14296	14441	
1/2"	#30 (.1285)	1/4"-28	1-5/32"	SC-8-W	13863	14007	14152	14297	14442	
1/2"	5/32 (.1562)	1/4"-28	1-5/32"	SC-8-W	13864	14008	14153	14298	14443	
1/2"	#21 (.1590)	1/4"-28	1-5/32"	SC-8-W	13866	14010	14155	14300	14445	
1/2"	3/16 (.1875)	1/4"-28	1-5/32"	SC-8-W	13867	14011	14156	14301	14446	
1/2"	#10 (.1935)	1/4"-28	1-5/32"	SC-8-W	13868	14012	14157	14302	14447	
1/2"	7/32 (.2187)	1/4"-28	1-5/32"	SC-8-W	13869	14013	14158	14303	14448	
1/2"	1/4 (.2500)	1/4"-28	1-5/32"	SC-8-W	13870	14014	14159	14304	14449	
5/8"	1/8 (.1250)	1/4"-28	1-5/32"	SC-10-W	13872	14016	14161	14306	14451	
5/8"	#30 (.1285)	1/4"-28	1-5/32"	SC-10-W	13873	14017	14162	14307	14452	
5/8"	5/32 (.1562)	1/4"-28	1-5/32"	SC-10-W	13874	14018	14163	14308	14453	
5/8"	#21 (.1590)	1/4"-28	1-5/32"	SC-10-W	13875	14019	14164	14309	14454	
5/8"	3/16 (.1875)	1/4"-28	1-5/32"	SC-10-W	13876	14020	14165	14310	14455	
5/8"	#10 (.1935)	1/4"-28	1-5/32"	SC-10-W	13878	14022	14167	14312	14457	

See more sizes page 67

Severance Tool Industries, Inc.
 Manufactures Code 662018
 Website: www.severancetool.com



Phone: 989-777-5500 Fax: 989-777-0602

E-Mail: severancetool@sbcglobal.net

Severance Tool Industries Inc. • POB 1866 • Saginaw, MI 48605

Chatter-Free™ Stop-Countersinks Cutters continued....



Carbide

Head Dia.	Pilot Dia.	Thread Dia.	Overall Length	Centerline Angle		41°		50°		60°	
				Included Angle	78°	82°	90°	100°	120°		
				Severance Name	Order Number	Order Number	Order Number	Order Number	Order Number	Order Number	
5/8"	7/32 (.2187)	1/4"-28	1-5/32"	SC-10-W	13879	14023	14168	14313	14458		
5/8"	1/4 (.2500)	1/4"-28	1-5/32"	SC-10-W	13880	14024	14169	14314	14459		
5/8"	5/16 (.3125)	1/4"-28	1-5/32"	SC-10-W	13881	14025	14170	14315	14460		
5/8"	3/8 (.3750)	1/4"-28	1-5/32"	SC-10-W	13882	14026	14171	14316	14461		
3/4"	5/32 (.1562)	3/8"-24	1-3/16"	S3-12-W	13895	14039	14184	14329	14474		
3/4"	#21 (.1590)	3/8"-24	1-3/16"	S3-12-W	13896	14040	14185	14330	14475		
3/4"	3/16 (.1875)	3/8"-24	1-3/16"	S3-12-W	13897	14041	14186	14331	14476		
3/4"	#10 (.1935)	3/8"-24	1-3/16"	S3-12-W	13898	14042	14187	14332	14477		
3/4"	7/32 (.2187)	3/8"-24	1-3/16"	S3-12-W	13900	14044	14189	14334	14479		
3/4"	1/4 (.2500)	3/8"-24	1-3/16"	S3-12-W	13901	14045	14190	14335	14480		
3/4"	"F" (.2570)	3/8"-24	1-3/16"	S3-12-W	13902	14046	14191	14336	14481		
3/4"	5/16 (.3125)	3/8"-24	1-3/16"	S3-12-W	13903	14047	14192	14337	14482		
3/4"	3/8 (.3750)	3/8"-24	1-3/16"	S3-12-W	13904	14048	14193	14338	14483		

Aircraft Style Rivet Shavers

Severance Rivet Shavers are used with Micro-Stop units. These end-cutting tools are designed to cut rivet heads, etc., flush to the surrounding surface. They are available in two series, multi-flute for fine finishing and two-flute for fast material removal.

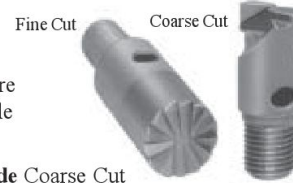

Carbide Fine Cut

Carbide Coarse Cut

Tool Dia.	Overall Length	Thread Size
5/16"	27/32"	1/4"-28
3/8"	27/32"	1/4"-28
7/16"	27/32"	1/4"-28
1/2"	27/32"	1/4"-28
9/16"	27/32"	1/4"-28
5/8"	27/32"	1/4"-28
3/4"	31/32"	3/8"-24
7/8"	31/32"	3/8"-24
1"	31/32"	3/8"-24

Number of Flutes	Severance Tool Name	EDP Order Number
14	RS-11	28480
14	RS-12	28481
14	RS-13	28482
14	RS-14	28483
16	RS-15	28484
16	RS-16	28485
18	RS-37	28486
24	RS-38	28487
24	RS-39	28488

Number of Flutes	Severance Tool Name	EDP Order Number
2	RS-21	28490
2	RS-22	28491
2	RS-23	28492
2	RS-24	28493
2	RS-25	28494
2	RS-26	28495
2	RS-47	28496
2	RS-48	28497
2	RS-49	28498

See pages 41 and 80 for handles



Special Stop-Countersinks and Units

Special diameters, pilots, flutes, and threads available on the stop countersinks. Special Units can be made like this vacuum unit pictured here.



REF. # 55370



Phone: 989-777-5500 Fax: 989-777-0602
 E-Mail: severancetool@sbcglobal.net

Severance Tool Industries Inc. • POB 1866 • Saginaw, MI 48605



Carbide End Mills

Severance solid micro grain carbide end mills are stocked in four-flute design, and are available in two and three-flute designs to order. Indicate the number of flutes desired at the end of the Tool Number' EM-250-W-3, for example. Experiment within the speed ranges listed at the right to produce the best chip on a given machine, workpiece, depth of cut, etc.

MATERIAL	S.F.P.M.
Cast Iron	75-200
Malleable Iron	75-200
Nickel Chrome	75-250
Stainless Steel	75-250
Carbon Steel	100-250
Nickel	100-250
Monel Metal	100-250
Free Cutting Steel	125-300
Brass/Bronze	125-300
Aluminum and Aluminum Alloys	125-375
Copper	125-375
Hard Rubber	150-450
Zinc Alloys	200-400
Fibre	200-400
Plastics	200-500

NOTE: S.F.P.M. = Surface Feet Per Minute

Standard Spiral

Head Dia.	Cutting Length	Overall Length	Severance Tool Name	EDP Order Number
1/8"	1/2"	1-1/2"	EM-125-W	36180
3/16"	5/8"	2"	EM-1875-W	36181
1/4"	3/4"	2"°	EM-250-W	36182
5/16"	3/4"	2-1/2"	EM-3125-W	36183
3/8"	7/8"	2-1/2"	EM-375-W	36184
1/2"	1"	3"	EM-500-W	36185
5/8"	1-1/4"	3-1/2"	EM-625-W	36186
3/4"	1-1/2"	4"	EM-750-W	36187

Slow Spiral

Head Dia.	Cutting Length	Overall Length	Severance Tool Name	EDP Order Number
1/8"	3/8"	1-1/2"	EMS-2-W	36188
3/16"	1/2"	1-1/2"	EMS-3-W	36189
1/4"	5/8"	2"	EMS-4-W	36190
5/16"	11/16"	2"	EMS-5-W	36191
3/8"	3/4"	2"	EMS-6-W	36192
1/2"	15/16"	2"	EMS-8-W	36193
5/8"	1-1/8"	2-1/2"	EMS10-W	36194
3/4"	1-1/4"	2-5/8"	EMS-12-W	36195



Carbide Carbo-Routs™

These solid carbide, multi-tooth routing mills will produce good finishes over a wide range of speeds. Fluting and tooth arrangements are designed to provide fast stock removal on many different materials.

Plain End

Cutting Dia.	Flute Length	Shank Dia.	Overall Length	Severance Tool Name	EDP Order Number
1/8"	1/2"	1/8"	1-1/2"	R-1	28685
3/16"	5/8"	1/4"	2"	R-2	28687
1/4"	1-1/4"	1/4"	3"	R-3	28691
3/8"	1-3/8"	3/8"	2-1/2"	R-4	28694
1/2"	1-1/2"	1/2"	3"	R-5	28696

Drill Style, End Cut

Cutting Dia.	Flute Length	Shank Dia.	Overall Length	Severance Tool Name	EDP Order Number
1/8"	1/2"	1/8"	1-1/2"	R-1-DP	28745
3/16"	1"	1/4"	2"	R-2-DP	28747
1/4"	1-1/4"	1/4"	3"	R-3-DP	28751
3/8"	1-3/8"	3/8"	2-1/2"	R-4-DP	28754
1/2"	1-1/2"	1/2"	3"	R-5-DP	28756

Severance Tool Industries, Inc.
 Manufactures Code 662018
 Website: www.severancetool.com



Phone: 989-777-5500 Fax: 989-777-0602

E-Mail: severancetool@sbcglobal.net

Severance Tool Industries Inc. • POB 1866 • Saginaw, MI 48605



Drill-Reamers

Severance Drill-Reamers are designed to drill and ream in one pass. The maximum length of holes recommended for standard drill-reamers is twice their respective diameters. Drill-Reamers of special design can be made for holes of greater length. For best results, drilling should be completed before starting to ream.

Severance Drill-Reamers are well suited for use with jigs and require only one size jig bushing.

High Speed Steel

Drill Reamer Size	Suggested Ream Length	Overall Length	Approx. Drill Length	Drill Dia. <small>-.001 +.000</small>	Severance Tool Name	EDP Order Number
3/16"	0.560	3-1/2"	0.20	.182	DR-3/16	26480
1/4"	0.750	4"	0.30	.242	DR-1/4	26503
5/16"	0.940	4-1/2"	0.40	.302	DR-5/16	26519
3/8"	1.130	5"	0.40	.368	DR-3/8	26534
1/2"	1.500	6"	0.60	.492	DR-1/2	26548



Ball Seat Reamers

Six-Flute Chatterless™ Design

Sizes – Tolerances – Radius size (1/2 tool diameter) is held to a plus or minus .0005". Variations from this tolerance, and other sizes at a nominal extra charge.

Uses – Severance Chatterless™ Ball Seat and Cavity Reamers are being used with outstanding success on steering gear, ball pin sockets, fuel injector plungers, valve push rod caps, gear shift lever seats, molds, etc.

High Speed Steel

Cutting Dia.	Ball Seat Radius	Overall Length	Shank Dia.	Shank Length	Severance Tool Name	EDP Order Number
1/4"	.1247/.1253	1-7/16"	3/16"	3/4"	BS-1/4	26030
3/8"	.1872/.1877	1-11/16"	1/4"	7/8"	BS-3/8	26031
1/2"	.2497/.2503	1-15/16"	3/8"	1-1/8"	BS-1/2	26032
5/8"	.3122/.3127	2-3/16"	3/8"	1-1/8"	BS-5/8	26033
3/4"	.3747/.3753	2-1/2"	1/2"	1-5/16"	BS-3/4	26034
7/8"	.4372/.4377	2-5/8"	1/2"	1-5/16"	BS-7/8	26035
1"	.4997/.5003	2-5/8"	1/2"	1-5/16"	BS-1	26036
1-1/4"	.6247/.6253	3"	3/4"	1-5/8"	BS-1-1/4	26037
1-1/2"	.7497/.7503	3-1/4"	3/4"	1-5/8"	BS-1-1/2	26038

Special Ball Seat Reamer

Special ball seat reamer for use on valve seats for a automotive valve lifter application.



REF. # 55350



Phone: 989-777-5500 Fax: 989-777-0602

E-Mail: severancetool@sbcglobal.net

Severance Tool Industries Inc. • POB 1866 • Saginaw, MI 48605



Micro Reamers™

Designed for smooth, chatter-free™ action, Micro-Reamers™ perform well in cast and malleable iron and in many nonferrous materials such as plastics, aluminum, etc. These tools feature solid carbide head with a steel body. The chatter-free tooth design and unique wiping flute geometry. A rigid setup, perfect alignment between the hole to be reamed, and the Micro-Reamer™, and the guide bushing, will produce accurate, finely finished holes. The drilled hole, to be reamed, should be approximately .006 to .016 undersize in holes from 3/8 to 1 inch in diameter. Standard tool tolerance is +.0002/-0.0000. Other sizes and tolerance specifications on request.

Carbide

Cutting Dia.	Shank Dia.	Overall Length	Shank Length	Severance Tool Name	EDP Order Number
1/8"	7/64"	2-3/4"	1-3/4"	RW-1250	26170
3/16"	11/64"	3-1/2"	2-3/8"	RW-1875	26171
3/8"	5/16"	5"	3-1/4"	RW-3750	26172
1/2"	7/16"	6"	4"	RW-5000	26173
9/16"	7/16"	6"	4"	RW-5625	26174



REF #53260

Other style Reamers are available as a special. Here is an example of a large taper reamer.



Micro-Center Reamers™

These tools are used to clean center holes in parts after heat treat or other processes. Micro-Center Reamers™ are particularly well suited in center lapping operations where speed is a factor and close tolerances must be maintained. They can be used in shifting centers to correct misalignment. Replace grinding wheels for: Dressing centers in hardened steel materials (will not chip out like center laps).

They will do an outstanding job on a wide variety of materials such as hardened tool steels; heat-treated forgings; and cast steels; Melanite and chilled iron, pitch and cut can be readily made to suit unusual conditions not responsive to the standard tool.

Carbide

Cutting Dia.	Nose Dia.	Shank Dia.	Overall Length	Shank Length	C/L Angle	Severance Tool Name	EDP Order Number
1/4"	.015	3/16"	1-1/2"	1-3/16"	30°	MCR-4-W	26130
3/8"	.020	1/4"	1-3/4"	1-3/4"	30°	MCR-6-W	26131
1/2"	.040	1/4"	2-1/4"	1-3/4"	30°	MCR-8-W	26132
5/8"	.050	3/8"	2-3/8"	1-1/2"	30°	MCR-10-W	26133
3/4"	.060	1/2"	2-11/16"	1-5/16"	30°	MCR-12-W	26134
1"	.090	1/2"	2-13/16"	1-5/16"	30°	MCR-16-W	26135

Note: All Micro-Center Reamers™ are TiN Coated at no extra charge!

Severance® Tool Industries, Inc.
 Manufactures Code 662018
 Website: www.severancetool.com

Severance®

Phone: 989-777-5500 Fax: 989-777-0602

E-Mail: severancetool@sbcglobal.net

Severance Tool Industries Inc. • POB 1866 • Saginaw, MI 48605

Hand Files are Great for Many Application

*Filing • Deburring • Shaping • Forming • Chamfering • Sharpening
Smoothing • Beveling • De-Flashing • Trimming and De-Scaling*

Severance Offers Four Types of Hand Files To Solve Virtually Every Application

Carbide – Severance Tool originated the Carbide Hand files which are ideal for use on hard materials, which quickly dull ordinary steel files. They are available in several sizes, styles, cuts and tooth patterns to meet almost any application requirements. Carbide files are stocked in coarse, medium and fine cuts, and in standard tooth pattern. Other cuts and patterns can be supplied promptly to order. **Severance Tool can regrind dull carbide files many times for a fraction of the new file cost.**

Cubic Boron Nitride – The CBN file segment has thousands of cubic boron nitride particles on its surface. Low heat generation makes it ideal for high speed rotary applications (such as working on a lathe or turning machinery) versus conventional files. Removes material quickly and easily without clogging or loading up. Ideal for use on High Speed Tool Steels, High Nickel Alloys, Hardened Structural Steels.

Standard Tooth Patterns



Standard Tooth

Curved Tooth

Diamond Grid
CBN Grid

Tooth Patterns Available

Standard Tooth – Used in deburring and smoothing many different types of materials; M-2, M-42, Cold and Hot Roll Steels. Used with light pressure for smooth finishes or to sharpen cutting surfaces on Steel, Aluminum, Cast Iron, Bronze.

Curved Tooth – Used in removing and smoothing different types of surfaces: Flat, Curved, and Round. Used for fast material removal with less material loading up on file. Used in the Auto Industries for shaping Sheet Metals, also used in Aluminum, Cast Iron, Bronze, Lead Zinc, and Plastics.

Diamond Grid – High stock removal rate makes jobs easier and faster. Deep recesses remove material quickly without clogging or loading up. Available in coarse or fine grits. Works on Carbide, Hardened Steel, Ceramics, Glass, Fiberglass, Composites, and more.

CBN Grid (Cubic Boron Nitride) – Used in high speed rotary applications because it will not generate heat. Removes material

Diamond – The diamond file segment has thousands of diamonds on its surface. Deep recesses remove material quickly and easily without clogging or loading up. High stock removal rate makes jobs faster and easier than conventional files. Very little pressure is used, thereby reducing worker fatigue and increasing output. Works on: Carbide, Glass, Fiberglass, Laminates, Graphite, Plexiglas, Hard Alloys, Hardened Dies, and more.

Steel – Tough, fatigue-resistant select grade of Molybdenum steel. Heat treated before final grinding to provide the optimum combination of properties for high performance. Steel Files will produce the same cutting action as our Carbide Files and are the ideal “medium” material where inexpensive files do not hold up and where chipping might occur using Carbide Files on an interrupted cut. Steel files may also be reground for new tool life.

Special Tooth Patterns

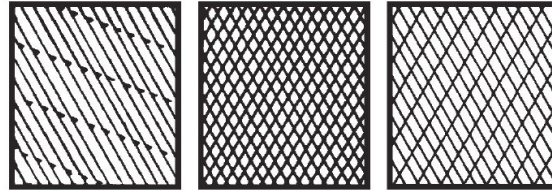

Chip Breaker

Rasp Tooth

Double Cut

NOTE: Standard tooth patterns will be supplied, unless specified.

easily without clogging or loading up. Available in coarse or fine grits. Works on High Speed Tool Steels, High Nickel Alloys and more.

Chip Breaker – Adding chip breakers will not reduce the finish but will make them cut a little better since no large shavings are produced.

Rasp Tooth – Ideal for fast material removal on relatively soft materials. Used with heavy pressure for rough finishes, shaping or sharpening cutting surfaces on Steel, Aluminum, Cast Iron, Bronze, Wood and other soft material. Rasp tooth pattern will produce a rougher finish than other tooth patterns.

Double Cut – Used with medium pressure for medium finishes, shaping or sharpening cutting surface on Steel, Aluminum, Cast Iron, and Bronze.



Phone: 989-777-5500 Fax: 989-777-0602

E-Mail: severancetool@sbcglobal.net

Severance Tool Industries Inc. • POB 1866 • Saginaw, MI 48605

Hand Files

6" Stroke, In Line Style
Cutting Area: 3/4" x 6"
Overall Length 11 3/4"



Carbide Hand Files Can Work on Materials That an Ordinary Steel File Won't Even Touch

High Speed Steel

Cut	Teeth Per Inch	Severance Tool Name	EDP Order Number
-----	----------------	---------------------	------------------

Standard Cut

Fine	40	FJ-3	20070
Med. Fine	31	FJ-4	20071
Medium	25	FJ-5	20072
Med. Coarse	20	FJ-6	20073
Coarse	16	FJ-7	20074

Curved Cut

Fine	40	FCT-3	20075
Med. Fine	31	FCT-4	20076
Medium	25	FCT-5	20077
Med. Coarse	20	FCT-6	20078
Coarse	16	FCT-7	20079

Chip Breaker

Fine	40	FJ-3-CB	20080
Med. Fine	31	FJ-4-CB	20081
Medium	25	FJ-5-CB	20082
Med. Coarse	20	FJ-6-CB	20083
Coarse	16	FJ-7-CB	20084

Rasp Cut

Fine	40	FJ-3-RASP	20085
Med. Fine	31	FJ-4-RASP	20086
Medium	25	FJ-5-RASP	20087
Med. Coarse	20	FJ-6-RASP	20088
Coarse	16	FJ-7-RASP	20089

Double Cut

Fine	40	FJ-3-DBL	20090
Med. Fine	31	FJ-4-DBL	20091
Medium	25	FJ-5-DBL	20092
Med. Coarse	20	FJ-6-DBL	20093
Coarse	16	FJ-7-DBL	20094

Borazon (CBN)

Abrasive Action	Grit SIZE	Severance Tool Name	EDP Order Number
Fine	200	FJ-CBN-F	19720
Coarse	100	FJ-CBN-C	19722

Carbide

Cut	Teeth Per Inch	Severance Tool Name	EDP Order Number
-----	----------------	---------------------	------------------

Standard Cut

Fine	40	FJ-3-W	19770
Med. Fine	31	FJ-4-W	19771
Medium	25	FJ-5-W	19772
Med. Coarse	20	FJ-6-W	19773
Coarse	16	FJ-7-W	19774

Curved Cut

Fine	40	FCT-3-W	19775
Med. Fine	31	FCT-4-W	19776
Medium	25	FCT-5-W	19777
Med. Coarse	20	FCT-6-W	19778
Coarse	16	FCT-7-W	19779

Chip Breaker

Fine	40	FJ-3-W-CB	19780
Med. Fine	31	FJ-4-W-CB	19781
Medium	25	FJ-5-W-CB	19782
Med. Coarse	20	FJ-6-W-CB	19783
Coarse	16	FJ-7-W-CB	19784

Rasp Cut

Fine	40	FJ-3-W-RASP	19785
Med. Fine	31	FJ-4-W-RASP	19786
Medium	25	FJ-5-W-RASP	19787
Med. Coarse	20	FJ-6-W-RASP	19788
Coarse	16	FJ-7-W-RASP	19789

Double Cut

Fine	40	FJ-3-W-DBL	19790
Med. Fine	31	FJ-4-W-DBL	19791
Medium	25	FJ-5-W-DBL	19792
Med. Coarse	20	FJ-6-W-DBL	19793
Coarse	16	FJ-7-W-DBL	19794

Diamond (DCF)

Abrasive Action	Grit SIZE	Severance Tool Name	EDP Order Number
Fine	200	FJ-DCF-F	19970
Coarse	100	FJ-DCF-C	19974

Severance hand files pay for themselves:

A customer reported: Hand filing long beads of tough titanium weld. The previous method consumed 40 to 60 16" steel files each day. Costing \$15.00 each, a total daily cost of approximately \$750.00. One Severance FJ-7-W carbide file did the same amount of work as 15 of the steel bastard files. A single savings of over \$500 per day. Plus Severance hand files may be reground many times at a fraction of the list price.

Severance Tool Industries, Inc.
Manufactures Code 662018
Website: www.severancetool.com



Phone: 989-777-5500 Fax: 989-777-0602

E-Mail: severancetool@sbcglobal.net

Severance Tool Industries Inc. • POB 1866 • Saginaw, MI 48605

Hand Files

3" Stroke, Offset Handle
With Knob, Cutting Area: 3/4" x 3"
Overall Length 9 1/2"

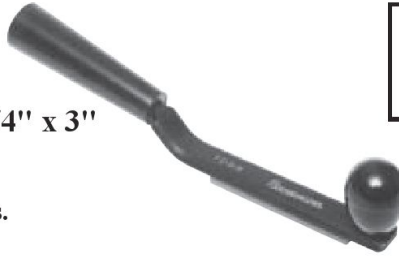

How much is your hand filing costing you?
 Severance Carbide Hand Files often outlast regular files 1 to 100, and the Severance files can be resharpened over and over again!

Can Be Resharpend Many Times.

High Speed Steel

Cut	Teeth Per Inch	Severance Tool Name	EDP Order Number
-----	----------------	---------------------	------------------

Standard Cut

Fine	40	FZ-3-K	20120
Med. Fine	31	FZ-4-K	20121
Medium	25	FZ-5-K	20122
Med. Coarse	20	FZ-6-K	20123
Coarse	16	FZ-7-K	20124

Curved Cut

Fine	40	FCZ-3-K	20125
Med. Fine	31	FCZ-4-K	20126
Medium	25	FCZ-5-K	20127
Med. Coarse	20	FCZ-6-K	20128
Coarse	16	FCZ-7-K	20129

Chip Breaker

Fine	40	FZ-3-K-CB	20130
Med. Fine	31	FZ-4-K-CB	20131
Medium	25	FZ-5-K-CB	20132
Med. Coarse	20	FZ-6-K-CB	20133
Coarse	16	FZ-7-K-CB	20134

Rasp Cut

Fine	40	FZ-3-K-RASP	20135
Med. Fine	31	FZ-4-K-RASP	20136
Medium	25	FZ-5-K-RASP	20137
Med. Coarse	20	FZ-6-K-RASP	20138
Coarse	16	FZ-7-K-RASP	20139

Double Cut

Fine	40	FZ-3-K-DBL	20140
Med. Fine	31	FZ-4-K-DBL	20141
Medium	25	FZ-5-K-DBL	20142
Med. Coarse	20	FZ-6-K-DBL	20143
Coarse	16	FZ-7-K-DBL	20144

Borazon (CBN)

Abrasive Action	Grit SIZE	Severance Tool Name	EDP Order Number
Fine	200	FZ-CBN-K-F	19747
Coarse	100	FZ-CBN-K-C	19749

Carbide

Cut	Teeth Per Inch	Severance Tool Name	EDP Order Number
-----	----------------	---------------------	------------------

Standard Cut

Fine	40	FZ-3-W-K	19820
Med. Fine	31	FZ-4-W-K	19821
Medium	25	FZ-5-W-K	19822
Med. Coarse	20	FZ-6-W-K	19823
Coarse	16	FZ-7-W-K	19824

Curved Cut

Fine	40	FCZ-3-W-K	19825
Med. Fine	31	FCZ-4-W-K	19826
Medium	25	FCZ-5-W-K	19827
Med. Coarse	20	FCZ-6-W-K	19828
Coarse	16	FCZ-7-W-K	19829

Chip Breaker

Fine	40	FZ-3-W-K-CB	19830
Med. Fine	31	FZ-4-W-K-CB	19831
Medium	25	FZ-5-W-K-CB	19832
Med. Coarse	20	FZ-6-W-K-CB	19833
Coarse	16	FZ-7-W-K-CB	19834

Rasp Cut

Fine	40	FZ-3-W-K-RASP	19835
Med. Fine	31	FZ-4-W-K-RASP	19836
Medium	25	FZ-5-W-K-RASP	19837
Med. Coarse	20	FZ-6-W-K-RASP	19838
Coarse	16	FZ-7-W-K-RASP	19839

Double Cut

Fine	40	FZ-3-W-K-DBL	19840
Med. Fine	31	FZ-4-W-K-DBL	19841
Medium	25	FZ-5-W-K-DBL	19842
Med. Coarse	20	FZ-6-W-K-DBL	19843
Coarse	16	FZ-7-W-K-DBL	19844

Diamond (DCF)

Abrasive Action	Grit SIZE	Severance Tool Name	EDP Order Number
Fine	200	FZ-DCF-K-F	19996
Coarse	100	FZ-DCF-K-C	20000

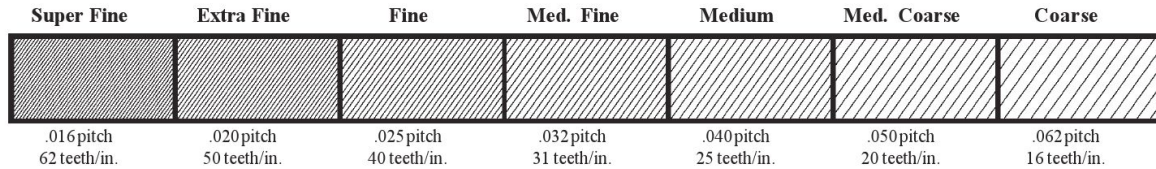



Phone: 989-777-5500 Fax: 989-777-0602

E-Mail: severancetool@sbcglobal.net

Severance Tool Industries Inc. • POB 1866 • Saginaw, MI 48605

Hand Files

Offset Handle, No Knob

3" Stroke, Cutting Area: 3/4" x 3"

Overall Length 8 3/4"

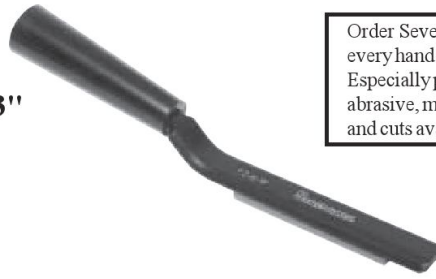

Order Severance Carbide Hand Files for every hand filing spot in your plant. Especially profitable when working hard, abrasive, materials. Special shapes, sizes, and cuts available on short notice.

Can Be Resharpend Many Times.

High Speed Steel

Cut	Teeth Per Inch	Severance Tool Name	EDP Order Number
-----	----------------	---------------------	------------------

Standard Cut

Fine	40	FZ-3	20095
Med. Fine	31	FZ-4	20096
Medium	25	FZ-5	20097
Med. Coarse	20	FZ-6	20098
Coarse	16	FZ-7	20099

Curved Cut

Fine	40	FCZ-3	20100
Med. Fine	31	FCZ-4	20101
Medium	25	FCZ-5	20102
Med. Coarse	20	FCZ-6	20103
Coarse	16	FCZ-7	20104

Chip Breaker

Fine	40	FZ-3-CB	20105
Med. Fine	31	FZ-4-CB	20106
Medium	25	FZ-5-CB	20107
Med. Coarse	20	FZ-6-CB	20108
Coarse	16	FZ-7-CB	20109

Rasp Cut

Fine	40	FZ-3-RASP	20110
Med. Fine	31	FZ-4-RASP	20111
Medium	25	FZ-5-RASP	20112
Med. Coarse	20	FZ-6-RASP	20113
Coarse	16	FZ-7-RASP	20114

Double Cut

Fine	40	FZ-3-DBL	20115
Med. Fine	31	FZ-4-DBL	20116
Medium	25	FZ-5-DBL	20117
Med. Coarse	20	FZ-6-DBL	20118
Coarse	16	FZ-7-DBL	20119

Borazon (CBN)

Abrasive Action	Grit SIZE	Severance Tool Name	EDP Order Number
Fine	200	FZ-CBN-F	19738
Coarse	100	FZ-CBN-C	19740

Carbide

Cut	Teeth Per Inch	Severance Tool Name	EDP Order Number
-----	----------------	---------------------	------------------

Standard Cut

Fine	40	FZ-3-W	19795
Med. Fine	31	FZ-4-W	19796
Medium	25	FZ-5-W	19797
Med. Coarse	20	FZ-6-W	19798
Coarse	16	FZ-7-W	19799

Curved Cut

Fine	40	FCZ-3-W	19800
Med. Fine	31	FCZ-4-W	19801
Medium	25	FCZ-5-W	19802
Med. Coarse	20	FCZ-6-W	19803
Coarse	16	FCZ-7-W	19804

Chip Breaker

Fine	40	FZ-3-W-CB	19805
Med. Fine	31	FZ-4-W-CB	19806
Medium	25	FZ-5-W-CB	19807
Med. Coarse	20	FZ-6-W-CB	19808
Coarse	16	FZ-7-W-CB	19809

Rasp Cut

Fine	40	FZ-3-W-RASP	19810
Med. Fine	31	FZ-4-W-RASP	19811
Medium	25	FZ-5-W-RASP	19812
Med. Coarse	20	FZ-6-W-RASP	19813
Coarse	16	FZ-7-W-RASP	19814

Double Cut

Fine	40	FZ-3-W-DBL	19815
Med. Fine	31	FZ-4-W-DBL	19816
Medium	25	FZ-5-W-DBL	19817
Med. Coarse	20	FZ-6-W-DBL	19818
Coarse	16	FZ-7-W-DBL	19819

Diamond (DCF)

Abrasive Action	Grit SIZE	Severance Tool Name	EDP Order Number
Fine	200	FZ-DCF-F	19983
Coarse	100	FZ-DCF-C	19987

Super Fine	Extra Fine	Fine	Med. Fine	Medium	Med. Coarse	Coarse
.016pitch 62 teeth/in.	.020pitch 50 teeth/in.	.025pitch 40 teeth/in.	.032pitch 31 teeth/in.	.040pitch 25 teeth/in.	.050pitch 20 teeth/in.	.062pitch 16 teeth/in.

Severance Tool Industries, Inc.
Manufactures Code 662018
Website: www.severancetool.com



Phone: 989-777-5500 Fax: 989-777-0602

E-Mail: severancetool@sbcglobal.net

Severance Tool Industries Inc. • POB 1866 • Saginaw, MI 48605

Hand Files

3" Stroke, Plain Style

Cutting Area: 3/4" x 3"

Overall Length 6"



These Carbide Files are "Designed" for One Hand Operations!

High Speed Steel

Cut	Teeth Per Inch	Severance Tool Name	EDP Order Number
-----	----------------	---------------------	------------------

Standard Cut

Fine	40	FS-3	20145
Med. Fine	31	FS-4	20146
Medium	25	FS-5	20147
Med. Coarse	20	FS-6	20148
Coarse	16	FS-7	20149

Curved Cut

Fine	40	FCS-3	20150
Med. Fine	31	FCS-4	20151
Medium	25	FCS-5	20152
Med. Coarse	20	FCS-6	20153
Coarse	16	FCS-7	20154

Chip Breaker

Fine	40	FS-3-CB	20155
Med. Fine	31	FS-4-CB	20156
Medium	25	FS-5-CB	20157
Med. Coarse	20	FS-6-CB	20158
Coarse	16	FS-7-CB	20159

Rasp Cut

Fine	40	FS-3-RASP	20160
Med. Fine	31	FS-4-RASP	20161
Medium	25	FS-5-RASP	20162
Med. Coarse	20	FS-6-RASP	20163
Coarse	16	FS-7-RASP	20164

Double Cut

Fine	40	FS-3-DBL	20165
Med. Fine	31	FS-4-DBL	20166
Medium	25	FS-5-DBL	20167
Med. Coarse	20	FS-6-DBL	20168
Coarse	16	FS-7-DBL	20169

Borazon (CBN)

Abrasive Action	Grit SIZE	Severance Tool Name	EDP Order Number
Fine	200	FS-CBN-F	19750
Coarse	100	FS-CBN-C	19751

Carbide

Cut	Teeth Per Inch	Severance Tool Name	EDP Order Number
-----	----------------	---------------------	------------------

Standard Cut

Fine	40	FS-3-W	19845
Med. Fine	31	FS-4-W	19846
Medium	25	FS-5-W	19847
Med. Coarse	20	FS-6-W	19848
Coarse	16	FS-7-W	19849

Curved Cut

Fine	40	FCS-3-W	19850
Med. Fine	31	FCS-4-W	19851
Medium	25	FCS-5-W	19852
Med. Coarse	20	FCS-6-W	19853
Coarse	16	FCS-7-W	19854

Chip Breaker

Fine	40	FS-3-W-CB	19855
Med. Fine	31	FS-4-W-CB	19856
Medium	25	FS-5-W-CB	19857
Med. Coarse	20	FS-6-W-CB	19858
Coarse	16	FS-7-W-CB	19859

Rasp Cut

Fine	40	FS-3-W-RASP	19860
Med. Fine	31	FS-4-W-RASP	19861
Medium	25	FS-5-W-RASP	19862
Med. Coarse	20	FS-6-W-RASP	19863
Coarse	16	FS-7-W-RASP	19864

Double Cut

Fine	40	FS-3-W-DBL	19865
Med. Fine	31	FS-4-W-DBL	19866
Medium	25	FS-5-W-DBL	19867
Med. Coarse	20	FS-6-W-DBL	19868
Coarse	16	FS-7-W-DBL	19869

Diamond (DCF)

Abrasive Action	Grit SIZE	Severance Tool Name	EDP Order Number
Fine	200	FS-DCF-F	20009
Coarse	100	FS-DCF-C	20013

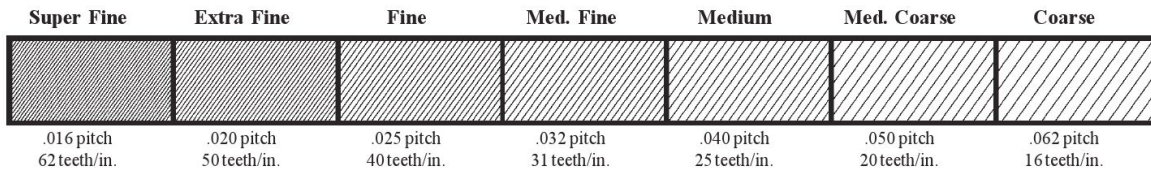



Phone: 989-777-5500 Fax: 989-777-0602
 E-Mail: severancetool@sbcglobal.net

Severance Tool Industries Inc. • POB 1866 • Saginaw, MI 48605



Hand Files
 1-1/2" Stroke, Plain Style
 Cutting Area: 3/8" x 1-1/2"
 Overall Length 6"

Can Be Resharpend Many Times.

High Speed Steel

Cut	Teeth Per Inch	Severance Tool Name	EDP Order Number
-----	----------------	---------------------	------------------

Standard Cut

Super Fine	62	FE-1	20170
Extra Fine	50	FE-2	20171
Fine	40	FE-3	20172
Med. Fine	31	FE-4	20173
Medium	25	FE-5	20174

Curved Cut

Super Fine	62	FCE-1	20175
Extra Fine	50	FCE-2	20176
Fine	40	FCE-3	20177
Med. Fine	31	FCE-4	20178
Medium	25	FCE-5	20179

Chip Breaker

Super Fine	62	FE-1-CB	20180
Extra Fine	50	FE-2-CB	20181
Fine	40	FE-3-CB	20182
Med. Fine	31	FE-4-CB	20183
Medium	25	FE-5-CB	20184

Rasp Cut

Super Fine	62	FE-1-RASP	20185
Extra Fine	50	FE-2-RASP	20186
Fine	40	FE-3-RASP	20187
Med. Fine	31	FE-4-RASP	20188
Medium	25	FE-5-RASP	20189

Double Cut

Super Fine	62	FE-1-DBL	20190
Extra Fine	50	FE-2-DBL	20191
Fine	40	FE-3-DBL	20192
Med. Fine	31	FE-4-DBL	20193
Medium	25	FE-5-DBL	20194

Borazon (CBN)

Abrasive Action	Grit Size	Severance Tool Name	EDP Order Number
Fine	200	FE-CBN-F	19756
Coarse	100	FE-CBN-C	19758

Carbide

Cut	Teeth Per Inch	Severance Tool Name	EDP Order Number
-----	----------------	---------------------	------------------

Standard Cut

Super Fine	62	FE-1-W	19870
Extra Fine	50	FE-2-W	19871
Fine	40	FE-3-W	19872
Med. Fine	31	FE-4-W	19873
Medium	25	FE-5-W	19874

Curved Cut

Super Fine	62	FCE-1-W	19875
Extra Fine	50	FCE-2-W	19876
Fine	40	FCE-3-W	19877
Med. Fine	31	FCE-4-W	19878
Medium	25	FCE-5-W	19879

Chip Breaker

Super Fine	62	FE-1-W-CB	19880
Extra Fine	50	FE-2-W-CB	19881
Fine	40	FE-3-W-CB	19882
Med. Fine	31	FE-4-W-CB	19883
Medium	25	FE-5-W-CB	19884

Rasp Cut

Super Fine	62	FE-1-W-RASP	19885
Extra Fine	50	FE-2-W-RASP	19886
Fine	40	FE-3-W-RASP	19887
Med. Fine	31	FE-4-W-RASP	19888
Medium	25	FE-5-W-RASP	19889

Double Cut

Super Fine	62	FE-1-W-DBL	09890
Extra Fine	50	FE-2-W-DBL	19891
Fine	40	FE-3-W-DBL	19892
Med. Fine	31	FE-4-W-DBL	19893
Medium	25	FE-5-W-DBL	19894

Diamond (DCF)

Abrasive Action	Grit Size	Severance Tool Name	EDP Order Number
Fine	200	FE-DCF-F	20022
Coarse	100	FE-DCF-C	20026

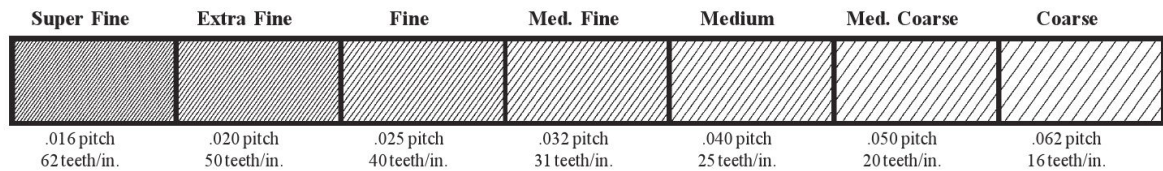

Severance Tool Industries, Inc.
 Manufactures Code 662018
 Website: www.severancetool.com



Phone: 989-777-5500 Fax: 989-777-0602
 E-Mail: severancetool@sbcglobal.net

Severance Tool Industries Inc. • POB 1866 • Saginaw, MI 48605



Die Files

Severance carbide Die Files are used for finishing work on hardened materials. All have 2" long cutting surfaces and are available in cuts and tooth patterns to specification. Handles are supplied with all Die Files.

Below tools will be supplied with standard spiral – medium cut.

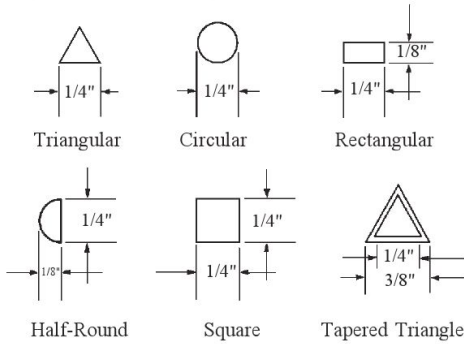

Carbide

Cutting Surface	Severance Shape	Severance Tool Name	EDP Order Number
2"	Triangular	DFT-1/4-STD	20270
2"	Circular	DFC-1/4-STD	20275
2"	Rectangular	DFR-1/4-STD	20280
2"	Half-Round	DFHR-1/4-STD	20285
2"	Square	DFS-1/4-STD	20290
2"	Tapered Triangle	DFTT-1/4-STD	20295

Carbide Machine Files

Carbide machine files can cut hardened steel, often eliminating the need for annealing and rehardening critical tools. These files are custom made to specified sizes, shapes, cuts and mounting dimensions. Many variations of the Severance Carbide Hand File maybe obtained for unusual filing applications. Machine mounted, automatic deburring applications of Special Severance Carbide Files are steadily increasing and proving very successful. Submit details of your filing and deburring problems - attention to our Engineering Department.

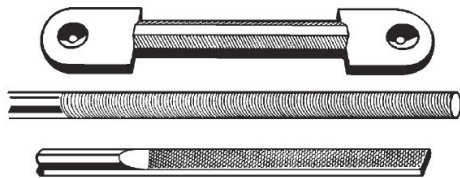

Tools Made To Your Specifications

How much is your hand filing costing you? Severance Carbide Hand Files often outlast regular files 1 to 100, and the Severance files can be resharpened over and over again!



Carbide Way Scraper

Over all length is approximately 21 inches, the Carbide Scraper Blade has a 3" radius cutting edge, is 1/16" thick, 1-1/4" wide, and is hollow ground. Easy to hold handle and end designed to scrape and resrape machine ways.

REF. #55000
This is a special Way Scraper used for machine way repair.



REF. #55533
This is a special hand file made with a special handle for a customers application.



Phone: 989-777-5500 Fax: 989-777-0602
 E-Mail: severancetool@sbcglobal.net

Severance Tool Industries Inc. • POB 1866 • Saginaw, MI 48605

Steel

Straight Shanks

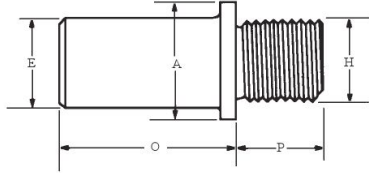

"H" Thread Size	"E" Shank Dia.	"P" Thread Length	"O" Shank Length	"A" Shoulder Dia.	Severance Tool Name	EDP Order Number
1/4"-28	1/4"	1/4"	1-3/4"	3/8"	4	34060
1/4"-28	3/8"	1/4"	1-3/4"	3/8"	E-2	34061
1/4"-28	1/2"	1/4"	1-3/4"	1/2"	G-2	34062
5/16"-24	1/4"	5/16"	1-3/4"	7/16"	14	34063
5/16"-24	3/8"	5/16"	1-3/4"	7/16"	E-12	34064
5/16"-24	1/2"	5/16"	1-3/4"	1/2"	G-12	34065
3/8"-24	1/4"	3/8"	1-3/4"	1/2"	24	34066
3/8"-24	3/8"	3/8"	1-3/4"	1/2"	E-22	34067
3/8"-24	1/2"	3/8"	1-3/4"	1/2"	G-22	34068
3/8"-24	5/8"	3/8"	1-3/4"	5/8"	I-22	34069
1/2"-20	3/8"	1/2"	1-3/4"	5/8"	E-32	34070
1/2"-20	1/2"	1/2"	1-3/4"	5/8"	G-32	34071
1/2"-20	5/8"	1/2"	1-3/4"	5/8"	I-32	34072
1/2"-20	3/4"	1/2"	1-3/4"	3/4"	J-33	34073
1/2"-20	1"	1/2"	1-3/4"	2"	L-33	34074
5/8"-18	3/8"	5/8"	1-3/4"	3/4"	E-42	34075
5/8"-18	1/2"	5/8"	1-3/4"	3/4"	G-42	34076
5/8"-18	5/8"	5/8"	1-3/4"	3/4"	I-42	34077
5/8"-18	3/4"	5/8"	1-3/4"	7/8"	J-43	34078
5/8"-18	1"	5/8"	2"	1"	L-43	34079
3/4"-16	1/2"	5/8"	1-3/4"	7/8"	G-52	34080
3/4"-16	5/8"	5/8"	1-3/4"	7/8"	I-52	34081
3/4"-16	3/4"	5/8"	1-3/4"	7/8"	J-53	34082
3/4"-16	1"	5/8"	2"	1"	L-53	34083
1"-14	1"	3/4"	2"	1-3/16"	L-63	34084
1-1/4"-12	1"	3/4"	2"	1-1/2"	L-73	34085

Steel



Glenzer Sleeve

O.D. Taper	Fits Shank Diameter	Glenzer NO.	EDP Order Number
2 M.T.	13/32"	778932	36210
3 M.T.	3/4"	778954	36211
4 M.T.	1"	778970	36212

Glenzer Sleeve

To be used with Severance Heavy Duty Countersinks and straight tanged shanks below. Other sizes available upon request.

Straight Shanks with Tang

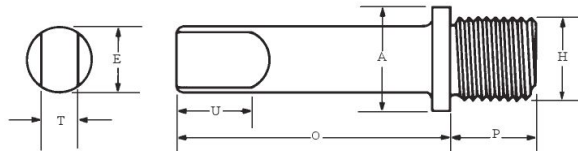

Steel

"H" Thread Size	"E" Shank Dia.	"P" Thread Length	"O" Shank Length	"A" Shoulder Dia.	"U" Tang Length	"T" Tang Thickness	Severance Tool Name	EDP Order Number
1/4"-28"	1/4"	1/4"	1/3/4"	3/8"	5/16"	.122	TX-4	34135
1/4"-28	13/32"	1/4"	1/3/4"	13/32"	7/16"	.242	TZ-3	34136
5/16"-24	1/4"	5/16"	1/3/4"	7/16"	5/16"	.122	TX-14	34137
5/16"-24	13/32"	5/16"	1/3/4"	7/16"	7/16"	.242	TZ-13	34138
3/8"-24	1/4"	3/8"	1/3/4"	1/2"	5/16"	.122	TX-24	34139
3/8"-24	13/32"	3/8"	1/3/4"	1/2"	7/16"	.242	TZ-23	34140
1/2"-20	13/32"	1/2"	1/3/4"	5/8"	7/16"	.242	TZ-33	34141
1/2"-20	9/16"	1/2"	1/3/4"	5/8"	1/2"	.303	TH-33	34142
5/8"-18	13/32"	5/8"	1/3/4"	7/8"	7/16"	.242	TZ-43	34143
5/8"-18	9/16"	5/8"	1/3/4"	3/4"	1/2"	.303	TH-43	34144
3/4"-16	9/16"	5/8"	1/3/4"	7/8"	1/2"	.303	TH-53	34145

Severance Tool Industries, Inc.
 Manufactures Code 662018
 Website: www.severancetool.com



Phone: 989-777-5500 Fax: 989-777-0602

E-Mail: severancetool@sbcglobal.net

Severance Tool Industries Inc. • POB 1866 • Saginaw, MI 48605

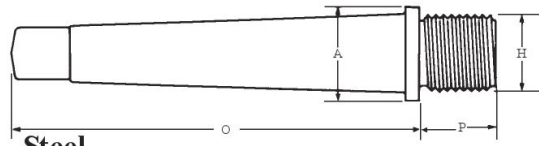

Tapered Shanks

Steel

"H" Thread Size	Morse Taper #	"E" Shank Dec.	"P" Thread Length	"O" Shank Length	"A" Shoulder Dia.	Severance Tool Name	EDP Order Number
1/4"-28	#1 MT	(.475)	1/4"	2-13/16"	1/2"	M1-C	34160
1/4"-28	#2 MT	(.700)	1/4"	3-3/8"	23/32"	M2-C	34161
5/16"-24	#1 MT	(.475)	5/16"	2-3/4"	1/2"	M1-D	34162
5/16"-24	#2 MT	(.700)	5/16"	3-5/16"	23/32"	M2-D	34163
3/8"-24	#1 MT	(.475)	3/8"	2-11/16"	1/2"	M1-E	34164
3/8"-24	#2 MT	(.700)	3/8"	3-1/4"	23/32"	M2-E	34165
3/8"-24	#3 MT	(.938)	3/8"	4"	15/16"	M3-E	34166
1/2"-20	#1 MT	(.475)	1/2"	2-3/4"	5/8"	M1-G	34167
1/2"-20	#2 MT	(.700)	1/2"	3-1/8"	23/32"	M2-G	34168
1/2"-20	#3 MT	(.938)	1/2"	3-7/8"	15/16"	M3-G	34169
5/8"-18	#1 MT	(.475)	5/8"	2-11/16"	13/32"	M1-I	34170
5/8"-18	#2 MT	(.700)	5/8"	3-1/4"	15/16"	M2-I	34171
5/8"-18	#3 MT	(.938)	5/8"	3-7/8"	15/16"	M3-I	34172
5/8"-18	#4 MT	(1.231)	5/8"	5"	1-1/4"	M4-I	34173
3/4"-16	#1 MT	(.475)	5/8"	2-11/16"	15/32"	M1-J	34174
3/4"-16	#2 MT	(.700)	5/8"	3-1/4"	15/16"	M2-J	34175
3/4"-16	#3 MT	(.938)	5/8"	3-7/8"	15/16"	M3-J	34176
3/4"-16	#4 MT	(1.231)	5/8"	5"	1-1/4"	M4-J	34177
1"-14	#2 MT	(.700)	3/4"	3-1/4"	1-1/4"	M2-L	34178
1"-14	#3 MT	(.938)	3/4"	4"	1-1/4"	M3-L	34179
1"-14	#4 MT	(1.231)	3/4"	4-7/8"	1-1/4"	M4-L	34180
1-1/4"-12	#3 MT	(.938)	3/4"	4"	1-5/8"	M3-N	34181
1-1/4"-12	#4 MT	(1.231)	3/4"	5-1/8"	1-3/4"	M4-N	34182
1-1/4"-12	#5 MT	(1.748)	3/4"	6"	1-3/4"	M5-N	34183
1-1/2"-12	#3 MT	(.938)	3/4"	4"	1-5/8"	M3-P	34184
1-1/2"-12	#4 MT	(1.231)	3/4"	5-1/8"	1-3/4"	M4-P	34185
1-1/2"-12	#5 MT	(1.748)	3/4"	6"	1-3/4"	M5-P	34186

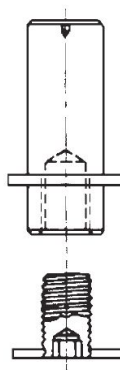

Disc Cutter Arbors

DIAMETER	SEVERANCE TOOL NAME	EDP ORDER NUMBER
1"	SH-3&4	17390
1"	SH-5	17392
1"	SH-6	17393
1"	SH-8	17394



Phone: 989-777-5500 Fax: 989-777-0602

E-Mail: severancetool@sbcglobal.net

Severance Tool Industries Inc. • POB 1866 • Saginaw, MI 48605

Straight Shanks for QC and Piloted Aircraft Countersinks

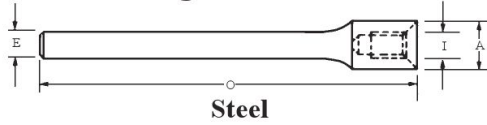

Steel

To be used with Severance Quick Change Countersinks 3N1-QC™ on page 59 and Severance Chatter Free™ Aircraft and Piloted countersinks on pages 65-67.

Thread Size	Shank Dia.		Overall Length	Shoulder Dia.	Severance Shank Name	EDP Order Number
	Frac.	Dec.				
1/4"-28	1/4"	.250	4"	7/16"	FM-2 Shank	34235
1/4"-28	1/2"	.500	6"	1/2"	FM-2x6 Shank	34239
1/4"-28	1/2"	.500	8"	1/2"	FM-2x8 Shank	34240
3/8"-24	1/4"	.250	4"	9/16"	FM-3 Shank	34236
3/8"-24	5/8"	.625	6"	5/8"	FM-3x6 Shank	34241
3/8"-24	5/8"	.625	8"	5/8"	FM-3x8 Shank	34242

Threaded Handles

Steel Shank with a Comfortable Wood Handle. Can be used with HR tools on page 43, and Deburring Tools on pages 32 & 35.

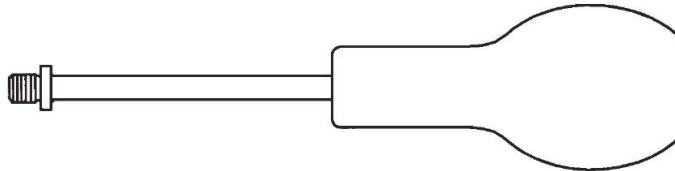

(O.A. length approx. 7")

Fits this Rad. Dbr. Ctr	Severance Tool Name	EDP Order Number
HR-1	H-100	34260
HR-2	H-100	34260
HR-3	H-100	34260
HR-5	H-100	34260
HR-10	H-100	34260
HR-15	H-100	34260
HR-20	H-110	34261
HR-25	H-110	34261
HR-30	H-121	34262
HR-35	H-121	34262
HR-40	H-121	34262
HR-45	H-131	34263
HR-50	H-131	34263

Whirly-Gig® Handle

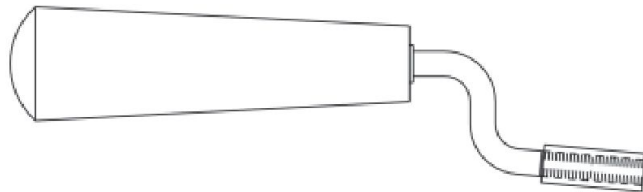

See Pages 41-42 for more details and options for Handles

The Severance Whirly-Gig® is designed for a variety of hand deburring operations. The handle holds any 1/4"-28 threaded tool. See page 41 for more details.

Whirly-Gig® Handle

Aprox. Overall Length	Thread Size	Severance Tool Name	EDP Order Number
6-1/2"	1/4"-28	Whirly-Gig®	34266

Speedy Handle™



The Severance Speedy Handle™ is designed for a variety of hand deburring operations. The handle holds any 1/4" diameter shank tool and has a ratchet like effect inside the handle. See page 42 for more details.

Speedy Handle™

Aprox. Overall Length	Arbor Hole Size	Severance Tool Name	EDP Order Number
4-1/4"	1/4"	Speedy Handle™	34269

Severance Tool Industries, Inc.

Manufactures Code 662018

Website: www.severancetool.com



Phone: 989-777-5500 Fax: 989-777-0602
 E-Mail: severancetool@sbcglobal.net

Severance Tool Industries Inc. • POB 1866 • Saginaw, MI 48605

Tool Sets & Kits



High Speed Steel Our most Popular H.S.S. Set
Midget Mills® Set 77 (7 Piece Set) EDP Order #29677

- Tools Included Are:**
 • GLA-EC • GGB • GLC • GKH • GIP • GLR • GJT



Carbide
Carbo-Mills™ Set 3-W (7 Piece Set) EDP Order #29570

- Tools Included Are:**
 • 3A-W • 3B-W • 3C-W • 3L-W • 3N-W • 3R-W • 3T-W



Carbide
Carbo-Mills™ Set 4-W (12 Piece Set) EDP Order #29571

- Tools Included Are:**
 • 4A3-W • 4A-W • 4B-W • 4C3-W • 4C-W • 4L-W • 4N-W
 • 4Q-W • 4T-W • 4R-W • 4Y-DE-W • 4Z-DE-W



Carbide
Carbo-Mills™ Set 6-W (8 Piece Set) EDP Order #29572

- Tools Included Are:**
 • 6A-W • 6B-W • 6C-W • 6L-W • 6N-W • 6Q-W • 6R-W
 • 6T-W



Carbide
Carbo-Mills™ Set 8-W (10 Piece Set) EDP Order #29573

- Tools Included Are:**
 • 8A-W • 8B-W • 8C-W • 8H-W • 8N-W • 8Q-W • 8R-W
 • 8T-W • 8Y-DE-W • 8Z-DE-W



Carbide Our most Popular Carbide Set
Carbo-Mills™ Set 16-W (10 Piece Set) EDP Order #29575

- Tools Included Are:**
 • 16A8-W • 12B8-W • 16B8-W • 16C8-W • 16H8-W • 16Q8-W • 12R8-W
 • 16R8-W • 16T8-W • 16U8-W



Carbide
Carbo-Mills™ Set 24-W (6 Piece Set) EDP Order #29576

- Tools Included Are:**
 • 12A8-W • 20A8-W • 12C8-W • 20C8-W • 12L8-W • 24R8-W



Phone: 989-777-5500 Fax: 989-777-0602
 E-Mail: severancetool@sbcglobal.net

Severance Tool Industries Inc. • POB 1866 • Saginaw, MI 48605



Carbide

Sever-Cuts™ Set 14-W (10 Piece Set) EDP Order #29574

Tools Included Are:

- CJA-W-4F • EJA-W-6F • GLA-W-8F • CJC-W-4F • EJC-W-6F • GLC-W-8F
- GKH-W-8F • EJR-W-6F • GLR-W-8F • IMR-W-8F



Carbide

Di-Car Mills™ Set 40-W (6 Piece Set) EDP Order #29646

Tools Included Are:

- A-44-H-W • A-48-D-W • B-44-H-W • C-48-H-W • C-44-D-W • H-44-H-W
- R-44-D-W • R-48-H-W



High Speed Steel

Our most Popular H.S.S. Junior Mill® Set

Junior Mills® Set 100 (10 Piece Set) EDP Order #29690

Tools Included Are:

- JR-1 • JR-2 • JR-3 • JR-4 • JR-5 • JR-6 • JR-7
- JR-8 • JR-9 • JR-10



High Speed Steel

Junior Mills® Set 101 (14 Piece Set) EDP Order #29692

Tools Included Are:

- JR-1 • JR-2 • JR-3 • JR-4 • JR-5 • JR-6 • JR-7
- JR-8 • JR-9 • JR-10 • JR-11 • JR-12 • JR-13 • JR-14



High Speed Steel

Junior Mills® Set 102 (20 Piece Set) EDP Order #29694

Tools Included Are:

- JR-1 • JR-2 • JR-3 • JR-4 • JR-5 • JR-6 • JR-7
- JR-8 • JR-9 • JR-10 • JR-11 • JR-12 • JR-13 • JR-14
- JR-15 • JR-16 • JR-17 • JR-18 • JR-19 • JR-20



Carbide

Our most Popular Carbide Junior Mill® Set

Junior Mills® Set 100-W (10 Piece Set) EDP Order #29691

Tools Included Are:

- JR-1-W • JR-2-W • JR-3-W • JR-4-W • JR-5-W • JR-6-W • JR-7-W
- JR-8-W • JR-9-W • JR-10-W



Carbide

Junior Mills® Set 101-W (14 Piece Set) EDP Order #29693

Tools Included Are:

- JR-1-W • JR-2-W • JR-3-W • JR-4-W • JR-5-W • JR-6-W • JR-7-W
- JR-8-W • JR-9-W • JR-10-W • JR-11-W • JR-12-W • JR-13-W • JR-14-W

Severance® Tool Industries, Inc.
 Manufactures Code 662018
 Website: www.severancetool.com



Phone: 989-777-5500 Fax: 989-777-0602

E-Mail: severancetool@sbcglobal.net

Severance Tool Industries Inc. • POB 1866 • Saginaw, MI 48605



Carbide

Junior Mills® Set 102-W (20 Piece Set) EDP Order #29695

Tools Included Are:

- JR-1-W • JR-2-W • JR-3-W • JR-4-W • JR-5-W • JR-6-W
- JR-7-W • JR-8-W • JR-9-W • JR-10-W • JR-11-W • JR-12-W
- JR-13-W • JR-14-W • JR-15-W • JR-16-W • JR-17-W • JR-18-W
- JR-19-W • JR-20-W



High Speed Steel

Our most Popular Miniature Deburring Tool Set

Lab Mills™ Set 60 (12 Piece Set) EDP Order #29666

Tools Included Are:

- LM1-093 • LM1-187 • LM2-093 • LM2-187 • LM3-187 • LM4-093
- LM4-187 • LM5-093 • LM6-187 • LM7-093 • LM8-093 • LM9-093



High Speed Steel

Extra Length Lab Mills™ Set 80 (12 Piece Set) EDP Order #29680

Tools Included Are:

- JD-1 • JD-2 • JD-3 • JD-4 • JD-5 • JD-6
- JD-7 • JD-8 • JD-9 • JD-10 • JD-11 • JD-12



High Speed Steel

Single Flute Countersinks Set 35 (5 Piece Set)

Tools include 1 piece of each of the following tool diameters:

- 1/4" 1/2" 3/4" 1"
- 1-1/4"

Centerline Angle	30°	41°	45°	50°	55°	60°
Included Angle	60°	82°	90°	100°	110°	120°
Severance Name	Order Number	Order Number	Order Number	Order Number	Order Number	Order Number
Set #35	29626	29627	29628	29629	29630	29631



High Speed Steel

Our most Popular Single Flute Set

Single Flute Countersinks Set 36 (6 Piece Set)

Tools include 1 piece of each of the following tool diameters:

- 1/4" 3/8" 1/2" 5/8"
- 3/4" 1"

Centerline Angle	30°	41°	45°	50°	55°	60°
Included Angle	60°	82°	90°	100°	110°	120°
Severance Name	Order Number	Order Number	Order Number	Order Number	Order Number	Order Number
Set #36	29632	29633	29634	29635	29636	29637



Phone: 989-777-5500 Fax: 989-777-0602

E-Mail: severancetool@sbcglobal.net

Severance Tool Industries Inc. • POB 1866 • Saginaw, MI 48605



High Speed Steel

Single Flute Countersinks Set 37 (10 Piece Set)

Tools include 1 piece of each of the following tool diameters:

- 1/4" 3/8" 1/2" 5/8"
- 3/4" 1" 1-1/4" 1-1/2"
- 1-3/4" 2"

Centerline Angle	30°	41°	45°	50°	55°	60°
Included Angle	60°	82°	90°	100°	110°	120°
Severance Name	Order Number	Order Number	Order Number	Order Number	Order Number	Order Number
Set #37	29638	29639	29640	29641	29642	29643



High Speed Steel

4-Flute Chatter-Free™ Econo-Sink® Set 30 (6 Piece Set)

Tools include 1 piece of each of the following tool diameters:

- 1/4" 3/8" 1/2" 5/8"
- 3/4" 1"

Centerline Angle	30°	41°	45°	50°	55°	60°
Included Angle	60°	82°	90°	100°	110°	120°
Severance Name	Order Number	Order Number	Order Number	Order Number	Order Number	Order Number
Set #30	29614	29615	29616	29617	29618	29619



Carbide

4-Flute Chatter-Free™ Econo-Sink® Set 30-W (6 Piece Set)

Tools include 1 piece of each of the following tool diameters:

- 1/4" 3/8" 1/2" 5/8"
- 3/4" 1"

Centerline Angle	30°	41°	45°	50°	55°	60°
Included Angle	60°	82°	90°	100°	110°	120°
Severance Name	Order Number	Order Number	Order Number	Order Number	Order Number	Order Number
Set #30-W	29620	29621	29622	29623	29624	29625



High Speed Steel

3N1® Drill Point Countersink Set 38 (4 Piece Set)

Tools include 1 piece of each of the following tool diameters:

- 1/4" 3/8" 1/2" 3/4"

Centerline Angle	30°	41°	45°	50°	55°	60°
Included Angle	60°	82°	90°	100°	110°	120°
Severance Name	Order Number	Order Number	Order Number	Order Number	Order Number	Order Number
Set #38	29700	29701	29702	29703	29704	29705



Carbide

3N1® Drill Point Countersink Set 38-W (4 Piece Set)

Tools include 1 piece of each of the following tool diameters:

- 1/4" 3/8" 1/2" 3/4"

Centerline Angle	30°	41°	45°	50°	55°	60°
Included Angle	60°	82°	90°	100°	110°	120°
Severance Name	Order Number	Order Number	Order Number	Order Number	Order Number	Order Number
Set #38-W	29730	29731	29732	29733	29734	29735

Severance® Tool Industries, Inc.
 Manufactures Code 662018
 Website: www.severancetool.com



Phone: 989-777-5500 Fax: 989-777-0602

E-Mail: severancetool@sbcglobal.net

Severance Tool Industries Inc. • POB 1866 • Saginaw, MI 48605



Tools include 1 piece of each of the following tool diameters:

- 1/4" 3/8" 1/2" 5/8"
- 3/4" 1"



Tools include 1 piece of each of the following tool diameters:

- 1/4" 3/8" 1/2" 5/8"
- 3/4" 1"

High Speed Steel

3N1® Drill Point Countersink Set 39 (6 Piece Set)

Centerline Angle	30°	41°	45°	50°	55°	60°
Included Angle	60°	82°	90°	100°	110°	120°
Severance Name	Order Number	Order Number	Order Number	Order Number	Order Number	Order Number
Set #39	29710	29711	29712	29713	29714	29715

Carbide

3N1® Drill Point Countersink Set 39-W (6 Piece Set)

Centerline Angle	30°	41°	45°	50°	55°	60°
Included Angle	60°	82°	90°	100°	110°	120°
Severance Name	Order Number	Order Number	Order Number	Order Number	Order Number	Order Number
Set #39-W	29740	29741	29742	29743	29744	29745



Tools include 1 piece of each of the following tool diameters:

- 1/4" 3/8" 1/2" 3/4"

High Speed Steel

Our most Popular H.S.S. Set

6-Flute Chatterless - Countersink™ Set 27 (4 Piece Set)

Centerline Angle	30°	41°	45°	50°	55°	60°
Included Angle	60°	82°	90°	100°	110°	120°
Severance Name	Order Number	Order Number	Order Number	Order Number	Order Number	Order Number
Set #27	29590	29591	29592	29593	29594	29595



Tools include 1 piece of each of the following tool diameters:

- 1/4" 3/8" 1/2" 3/4"

Carbide

Our most Popular Carbide Set

6-Flute Chatterless - Countersink™ Set 27-W (4 Piece Set)

Centerline Angle	30°	41°	45°	50°	55°	60°
Included Angle	60°	82°	90°	100°	110°	120°
Severance Name	Order Number	Order Number	Order Number	Order Number	Order Number	Order Number
Set #27-W	29596	29597	29598	29599	29600	29601



Tools include 1 piece of each of the following tool diameters:

- 1/4" 3/8" 1/2" 5/8"
- 3/4" 1"

High Speed Steel

6-Flute Chatterless - Countersink™ Set 29 (6 Piece Set)

Centerline Angle	30°	41°	45°	50°	55°	60°
Included Angle	60°	82°	90°	100°	110°	120°
Severance Name	Order Number	Order Number	Order Number	Order Number	Order Number	Order Number
SET #29	29602	29603	29604	29605	29606	29607



Phone: 989-777-5500 Fax: 989-777-0602

E-Mail: severancetool@sbcglobal.net

Severance Tool Industries Inc. • POB 1866 • Saginaw, MI 48605



Carbide

6-Flute Chatterless – Countersink™ Set 29-W (6 Piece Set)

Tools include 1 piece of each of the following tool diameters:

- 1/4"
- 3/8"
- 1/2"
- 5/8"
- 3/4"
- 1"

Centerline Angle	30°	41°	45°	50°	55°	60°
Included Angle	60°	82°	90°	100°	110°	120°
Severance Name	Order Number	Order Number	Order Number	Order Number	Order Number	Order Number
SET #29-W	29608	29609	29610	29611	29612	29613



Whirly-Gig® Sets		
<p>Whirly-Gig® Set #344 EDP#34268</p> <ul style="list-style-type: none"> 1 Whirly-Gig® Handle 1 Whirly-Gig® Extension 1 ID-5/8-30 1 ID-5/8-45 1 SC-7-41-.093 1 SC-7-45-.093 1 HR-10 1 Threaded Arbor 	<p>Whirly-Gig® Set #345 EDP#34271</p> <ul style="list-style-type: none"> 1 Whirly-Gig® Handle 1 Whirly-Gig® Holder-1/4 1 CK-1/4-45-DE 1 3N1-QC-1/2-45 1 Hex Wrench 	<p>Whirly-Gig® Set #346 EDP#34272</p> <ul style="list-style-type: none"> 1 Whirly-Gig® Handle 1 Whirly-Gig® Holder-1/4 1 CK-1/4-45-DE 1 CK-1/4-41-DE 1 3N1-QC-1/2-45 1 3N1-QC-3/8-45 1 IC-5/8-30 1 HR-10 1 Hex Wrench 1 Threaded Arbor

Set #344 is very popular.

One of our most popular sets. See Page 42 for more details



Speedy Handle™ Set 349	
EDP# 34270	
Speedy Handle™	
IIB	Ball Shaped Midget Mill®
ICS-5/8-45	Inside Chamfering Mill
ES-5/8-45-1/4	Four Flute Countersink



Countertop Display - Tool Master Set 811

Severance Tool Industries new Tool Master set is ideal for tool cribs, maintenance departments, and factory deburring areas. This set has been carefully designed and filled with our most popular cutting tools. This will allow you to have available, a wide variety of problem solving deburring tools for your various applications. This new unique display set has only an 8 1/2" x 11" foot print. Lay this page on your countertop for a quick size chart. This is available in **High Speed Steel (EDP #29696)** and **Carbide (EDP #29697)**. This is also an ideal distributor countertop display, and will assist your customer applications using a minimum amount of counter space.

Severance Tool Master Display Contains



<p>Midget Mills®</p> <p>GLA-EC GGB GLC GKH GIP GLR GJT</p>	<p>Tube End Deburring Cutter</p> <p>ED-TUBE</p>	<p>Junior Mills®</p> <p>JR-1 JR-2 JR-3 JR-4 JR-5 JR-6 JR-8 JR-9 JR-10 JR-11 JR-12 JR-20</p>	<p>Stop Countersinks</p> <p>SC-6-41-.125 SC-7-41-.156 SC-8-45-.187 SC-10-45-.250</p>
<p>Single Flute Countersinks</p> <p>1/4-SF-30 3/8-SF-30 1/2-SF-30 3/4-SF-30 1-SF-30</p>	<p>3N1® Drill Point Countersinks</p> <p>3N1-1/4-45 3N1-3/8-45 3N1-1/2-45 3N1-3/4-45 3N1-1-45</p>	<p>6 Flute Chatterless™ Countersinks</p> <p>CK-1/4-41 CK-3/8-41 CK-1/2-41 CK-3/4-41 CK-1-41</p>	<p>Stop Countersink Unit</p> <p>SC-24 UNIT</p>

Severance® Tool Industries, Inc.
Manufactures Code 662018
Website: www.severancetool.com



Phone: 989-777-5500 Fax: 989-777-0602

E-Mail: severancetool@sbcglobal.net

Severance Tool Industries Inc. • POB 1866 • Saginaw, MI 48605

Recommended Countersink Speeds and Feeds

MATERIAL	FEED PER TOOTH (FPT)	H.S.S. SPEED (SFM)	CARBIDE SPEED (SFM)
ALUMINUM/ALUMINUMALLOYS	.001-.002	150-250	300-500
BRASS/BRONZE	.001-.002	75-125	150-250
IRON - CAST (SOFT)	.001-.002	75-125	125-225
IRON - CAST (MEDIUM HARD)	.001-.002	50-100	100-175
IRON - MALLEABLE	.001-.002	80-90	90-150
MAGNESIUM/MAGNESIUMALLOYS	.001-.002	125-250	250-400
HIGH NICKEL STEEL	.001-.002	30-50	50-75
PLASTIC, BAKELITE	.001-.002	100-250	250-400
STEEL - MILD	.001-.002	70-100	80-170
STEEL - TOOL	.001-.002	50-60	60-100
STEEL - FORGINGS	.001-.002	40-50	50-80
STEEL - ALLOY (300-400 BRINELL)	.001-.002	20-30	30-50
STEEL - HIGH TENSILE (35-45 RC)	.001-.002	25-40	35-60
STEEL - HIGH TENSILE (45-50 RC)	.001-.002	15-25	25-40
STEEL - HIGH TENSILE (50-55 RC)	.001-.002	7-15	15-20
STAINLESS STEEL (FREE MACHINING)	.001-.002	30-80	80-125
STAINLESS STEEL (WORK HARDENING)	.001-.002	15-50	50-75
INCONELALLOY, HASTELLOY WROUGHT	.001-.002	15-20	25-35
HASTELLOY (CAST)	.001-.002	5-7	7-15

RPM = SFM x 3.82 ÷ CUTTER O.D.
IPR = FPT x NUMBER OF TEETH
IPM = IPR x RPM

THE ABOVE SURFACE FEET PER MINUTE ARE TO BE USED AS A GUIDE.
 USE OF GOOD QUALITY CUTTING FLUID IS RECOMMENDED.
 FOR ADDITIONAL INFORMATION CALL (989) 777-5500

CNC-K™ Precision Countersink Programming/Technical Information

Designed specifically for use in NC, CNC and preset machine tools, these precision countersinks feature Chatterless™ tooth geometry. Tight tolerances on angles, diameters and lengths assure setting accuracy. Available in 30°, 41°, 45°, 50°, 55° and 60° centerline angles. Other angles and sizes available upon request.

Technical and Programming Information

NOTE: For any depth the Countersink diameter expands in a direct ratio. As you travel in the (A) direction along the axis of the Countersink (X) expands in a direct relationship to angle (K) (forming an angle with the tangent of X/A).

Since the angle expands on both sides of the drilled hole; you must use 2 times the tangent of the angle for your ratio (R).

Angle (K)	Ratio (R) = $2 \frac{X}{A}$
30°	1.15
41°	1.74
45°	2.00
50°	2.38
55°	2.86
60°	3.46

Calculations
$C = H + RA$
$A = \frac{C - H}{R}$
$S = \frac{C - D}{R}$
$X = \frac{C - H}{2}$

Angle (K) TANGENT = $\frac{X}{A}$

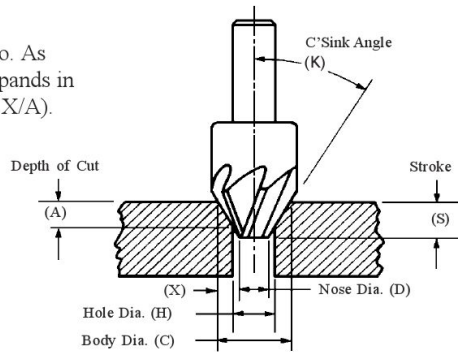

Example:

.500 hole diameter, countersink to .875 cut diameter with 41° angle (use NCK-1" - 41°)

$A = \frac{.875 - .500}{1.74} = .216$ $S = \frac{.875 - .203}{1.74} = .386$



Phone: 989-777-5500 Fax: 989-777-0602

E-Mail: severancetool@sbcglobal.net

Severance Tool Industries Inc. • POB 1866 • Saginaw, MI 48605

Severance[®] Contract Services

Severance Tool's Contract Service Division offers precision turning and grinding to the manufacturing industry from large corporations to smaller specialized companies. For over 75 years we have gained a wealth of experience in precision turning and grinding. Our experienced staff specialize in finishing your custom parts from wear parts, production parts, OEM parts, shafts, sleeves, and tooling.

We serve a varied customer base including Aircraft Industry, Communication, Oil Industry, Automotive, Defense, Medical Device Mfgs., OEM, Maintenance, R & D, Labs, and many more commercial manufacturers.

From a "one of a kind" (including research & development), to small batches, to continual runs... Its not a problem for us.

With our highly motivated and experienced staff and utilizing both traditional machinery and the latest in computerized precision technologies, we know that we can fulfill your specific requirements.

The company is proud of the reputation that it has established through the ability to fulfill its customers requirements and is determined to maintain the success it has enjoyed through continuing to provide a high quality service.

For more information call us at 989-777-5500 or e-mail to severancetool@sbcglobal.net

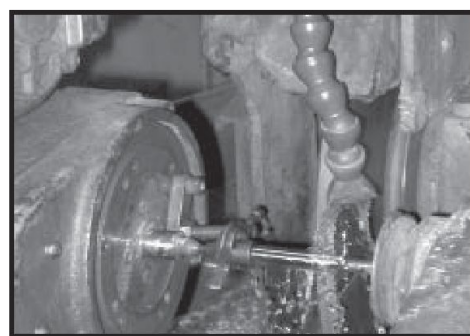
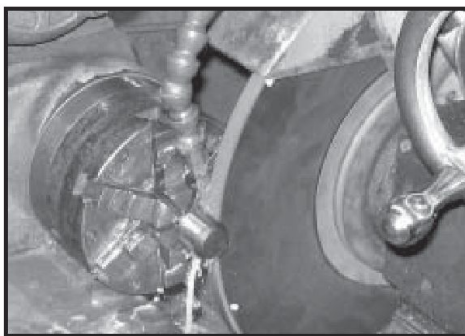
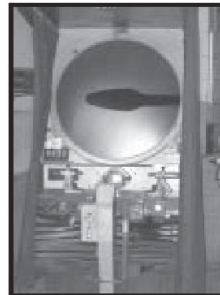
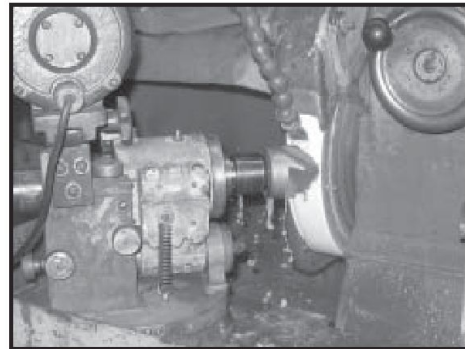

Severance[®] Tool Industries, Inc.
Manufactures Code 662018
Website: www.severancetool.com

Phone: 989-777-5500 Fax: 989-777-0602

E-Mail: severancetool@sbcglobal.net

Severance®

Severance Tool Industries Inc. • POB 1866 • Saginaw, MI 48605

Severance® Regrind Services

Severance Tool Industries, Inc. was founded in 1931, as a tool sharpening service for the automotive plants in the Saginaw area. Grinding techniques developed by Mr. Severance proved so successful that his reconditioned tools significantly outperformed the original cutters. After nearly eight decades, Severance has become a leading manufacturer of rotary cutting tools, but is still the nation's largest regrinding service.

Experience Pays

The Severance Regrind Department is staffed by the company's most experienced personnel because restoration is a more exacting task than original manufacture. The first challenge is to correctly identify incoming tools as to their brand, size, shape and catalog number (or drawing number in the case of specials). Then, the degree of damage is evaluated for each tool to determine the processing steps needed to restore it to original specifications.

Attention to Detail

Severance receives many tools for regrinding that are neither cataloged items (ours or other brands) nor Severance-manufactured specials. If these tools are not accompanied by a description or drawing, they go to our inspection department. Engineering prepares a drawing, based on identifiable dimensions and features of the tool. The customer may be called to resolve any remaining questions. A print is then retained in the incoming inspection file against future appearances of the tool.

Establishing Shape

Tools that need anything more than a light sharpening cut goes to the machine grinding department. Here, the basic shape of the tool is reestablished by removing enough material to get rid of dull edges and chips. After repeated regrindings, or when major damage is involved, the

tool may need refluting. This operation is also done in the machine regrinding department.

The Cutting Edge

The final step in the reconditioning of a cutting tool is "backing off" the cutting edge. This hand grinding operation removes material behind the edge at a specified angle, leaving a thin land to support the cutting edge. Final cutting tooth geometry determines the performance and durability of the tool, so our craftsmen adhere very closely to established specifications.

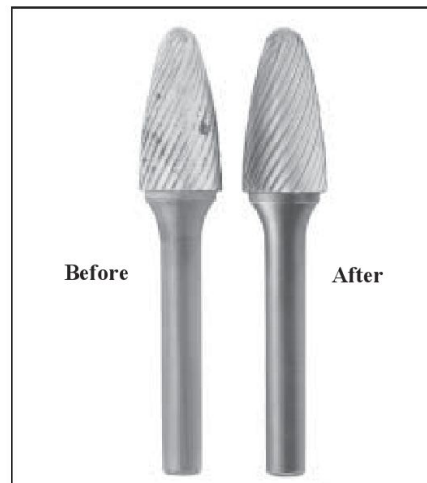

Severance®

Phone: 989-777-5500 Fax: 989-777-0602

E-Mail: severancetool@sbcglobal.net

Severance Tool Industries Inc. • POB 1866 • Saginaw, MI 48605

Regrinding

The photo at the right shows a six-flute Chatterless-Countersink™ which has become dull in service and was returned to Severance for restoration. It will receive our basic regrind service to the price listed in the current Price Supplement. After grinding, the tool will be slightly shorter than its original length, but will be functionally the same as new. When side cutting tools, such as Midget Mills®, router bits, milling cutters and saws, are reground, their working diameters are necessarily reduced.



Recutting

This Chatterless-Countersink™, identical when new to the one above, has been chipped rather badly. It is salvageable by grinding the teeth down to a point below the chips, then backing off the edges. As the amount of material that must be removed becomes larger, each tooth becomes thicker and the central diameter becomes larger. At some point, the flutes will have to be recut to preserve the working range of the tool. Recutting the flutes adds to the cost of reconditioning the tool. This expense can't be standardized, but it will be quoted on request.

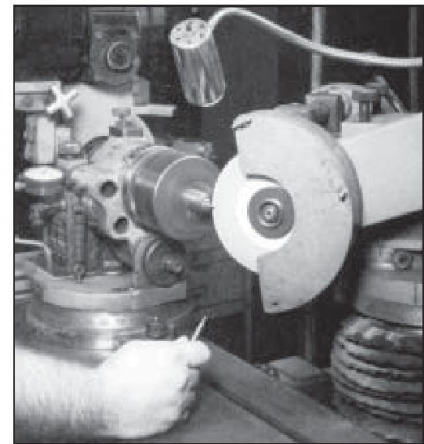

Reconditioning

The Chatterless-Countersink™ pictured here has experienced a real disaster. The damage extends so deeply into the carbide that there's not enough material left to re flute and regrind. This tool will require extra work and will be priced accordingly. We will provide a quotation before any work is done if requested to do so by the customer. Tools that are beyond repair will be returned at no charge, with no work done.

Some regrind customers request that a quotation be provided before work is begun on their orders. This can be done by telephone, fax, or correspondence, per your request. Most customers who have worked with Severance on a regular basis simply leave the regrind / recut / recondition decisions to us, knowing that they will get the best possible service at the most reasonable price.

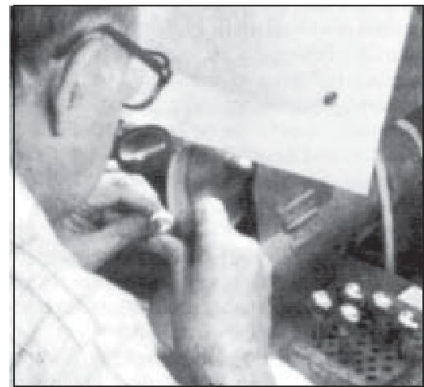

Severance® Tool Industries, Inc.
Manufactures Code 662018
Website: www.severancetool.com

90



Phone: 989-777-5500 Fax: 989-777-0602

E-Mail: severancetool@sbcglobal.net

Severance Tool Industries Inc. • POB 1866 • Saginaw, MI 48605

Special Tools And Modified Standards

Tooling

These special tools are designed to produce a complex hole shape in a single pass. They can incorporate as many steps, tapers, radii or contours as necessary. They are manufactured in sizes ranging from less than 1/8 inch in diameter to over four inches. They can usually be produced in either steel or carbide, and may be reground many times for extended service.

Modified Standard

Standard rotary tools can be customized in a variety of ways to better solve specific cutting applications. Special material removal requirements, nonstandard tooth pitches or cuts; meeting special material requirements or machine speeds . . . special shanks; extra long, threaded, flatted, over or under sized can be supplied. Even flexible shafts for deburring impossible-to-reach surfaces, have been created. Tools that are cataloged only in high speed steel can usually be supplied in carbide or titanium nitride coated, to extend tool life.

Severance has the advanced technology to solve most tooling requirements.

If It Can Be Machined With A Rotary Tool. Severance Can Provide The Tool To Do It.

Just send us your customer's special tool problem for prompt engineering analysis, recommendation and quotation via FAX (989)-777-0602. We'll respond with a solution that will be cost effective for your customer and profitable for you.

Some examples of specials and their uses

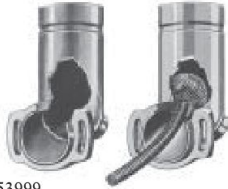

REF. # 53999
A Special Severance Flex-Shank Midget Mill®. Flexible shanks are used for those hard to reach inside deburring applications. Flex-Shanks are available in several diameters.

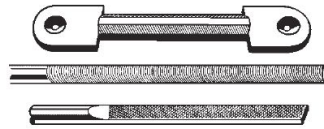

REF. # 55375
Special Severance Hand and Die Files. Special files for different customer applications. Available in carbide, high speed steel, diamond (DCF), or borazon (CBN).



REF. # 51916
Special Severance Deburring Tools. Special deburring tool with special cuts to meet customer needs.



REF. # 50766
A Special Severance Radius Countersink. Radius Countersinks are used to round off the edge of holes.



REF. # 55376
Special Severance Stop Countersinks. Special designs such as special number of flutes, special angles, special pilots, and special diameters.



REF. # 55374
Special Severance Chamfering Tools. Special inside and outside chamfering tool that is spring loaded to meet customer requirements.



REF. # 53260
A Special Severance Taper Reamer. Taper reamers for reaming pipe.



REF. # 51564
Here is a special threaded milling cutter.



REF. # 55377
A Special Severance Milling Cutter. Used to mill watchcases and backs without chatter and without collapsing the case is the feat performed by this tool.



REF. # 55378
Severance can do either small or large runs on special tools. Such as these Midget Mills® with a special cut.

These are considered special items and are not returnable for credit

Phone: 989-777-5500 Fax: 989-777-0602
 E-Mail: severancetool@sbcglobal.net

Severance[®]

Severance Tool Industries Inc. • POB 1866 • Saginaw, MI 48605

Some examples of specials and their uses



REF. # 55337
 This extra large Midget Mill[®] has a 4" diameter and was 8" long.



REF. # 55338
 This special Severance tool was put on the end of a handle and used to change light bulbs in high hard to reach places. Bulb Snatcher.



REF. # 55339
 This special Severance Midget Mill[®] was designed with a guard on each end.



REF. # 55340
 This special outside chamfer mill with a guide on it was designed to put a sharp angle on a customers part. Such as grounding rods.



REF. # 55341
 These Special Pencil Mills are used for milling teeth on oil and water rotary drilling bits (rock bits).



REF. # 55342
 Here is a special piloted counterbore.



REF. # 55343
 Here is a special designed piloted milling cutter made for a customers special needs.



REF. # 50766
 These Tools are used to deburr holes in automotive crank shafts. These tools can also be made to deburr a variety of hole applications.



REF. # 55344
 This tool was used to polish the inside of the old flash bulb shields on older cameras.



REF. # 55345
 This special pipe forming tool was use on the end of a pipe threader to form the end of a certain size pipe.



REF. # 55346
 Here is an example of a larger pipe forming cutter like the one seen to the left.



REF. # 55347
 This tool was used to radius the corner of a special part. This tool has a ring around the outside so that the cutter will only go so deep and is used as a stop.

These are considered special items and are not returnable for credit

Severance[®] Tool Industries, Inc.
 Manufactures Code 662018
 Website: www.severancetool.com



Phone: 989-777-5500 Fax: 989-777-0602

E-Mail: severancetool@sbcglobal.net

Severance Tool Industries Inc. • POB 1866 • Saginaw, MI 48605

Some examples of specials and their uses



REF. # 55348
A Special Severance Tough-Sink™. This countersink has 3 flats on the shank to prevent spinning in a drill chuck.



REF. # 55349
Special Severance ball shaped deburring tool.



REF. # 55350
Special Severance chatterless™ ball seat reamers. These tools are used on steering gears, ball pin sockets, fuel injector plungers, valve push rod caps, gear shift lever seats, molds, and many other applications.



REF. # 70502
Special Severance carbide metric chatterless-Countersink™ with a morse taper shank.

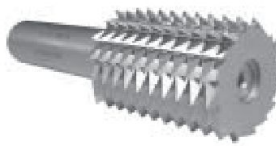

REF. # 51926
Special Flute geometry is used on this cutter to cut wafered cardboard.



REF. # 55351
A Special Fish Tail Severance Carbo-Routs™. For drilling and Contouring in fiberglass composite.



REF. # 55396
Severance Wheel Dresser. Used for dressing wheels



REF. # 51213
These special Severance crowning tools are used by the military for guns.



REF. # 55353



REF. # 51342



REF. # 51965

Special Severance Valve Seat Tools. These tools are used to form angles on pressure seating valves. Available in both inside and outside styles.



REF. # 55355
Special Severance carbide and H.S.S. disc and milling cutters can be provided for many applications.



REF. # 55356
Special drill point countersinks can be provided in a variety of angles and sizes.



REF. # 55357
here is an example of a special Severance forming tools. Used to form the mouthpiece on a coronet musical instrument.

These are considered special items and are not returnable for credit



Phone: 989-777-5500 Fax: 989-777-0602

E-Mail: severancetool@sbcglobal.net

Severance Tool Industries Inc. • POB 1866 • Saginaw, MI 48605

Some examples of specials and their uses



REF. # 51813
This is a midget mill made with straight teeth and chipbreakers to meet a customers needs. This design was used for surgical.



REF. # 50935
This special surgical burrs were made out of stainless steel for the medical industry.



REF. # 55359
Severance can grind the teeth on customer hip rasps for surgical applications.



REF. # 50656
Special Severance fining cutters are used for deburring in confined areas that are hard to reach.



REF. # 50600
Special grooving tools are available for a variety of grooving applications.



REF. # 55358
Special Severance end mills and counterbores can be supplied. Can be supplied with pilots on the end also.



REF. # 55360
Special hole saws can be provided for an array of applications



REF. # 55361
Severance can make special hollow mills to fit customer applications.



REF. # 55362
Here is an example of a special carbide insert rod end forming cutter made by Severance tool to fill a customer's needs.



REF. # 54443
This special Severance inside chamfer mill was used for deburring holes on a fiberglass boat.



REF. # 55363
This special cutter was used to cut Jean material for a fabric producer.



REF. # 52210
This tool was made to mill a groove in blocks of brick for kilns. The groove is used for heat coils.

These are considered special items and are not returnable for credit

Severance Tool Industries, Inc.
Manufactures Code 662018
Website: www.severancetool.com



Phone: 989-777-5500 Fax: 989-777-0602

E-Mail: severancetool@sbcglobal.net

Severance Tool Industries Inc. • POB 1866 • Saginaw, MI 48605

Some examples of specials and their uses



REF. # 55365

This is a Wood Burr with a coarse cut, double cut, and a large radius in the bottom of the flutes for removing chips when working on wood.



REF. # 55365

Solid finish ground rod can be ordered special with square unfinished ends with tolerances $+ .0000/- .0005$. Used for locating pins and special tools.



REF. # 55366

Solid finish ground rod can be ordered special with split both ends with tolerances $+ .0000/- .0005$ diameters and split of $.001/.000$ above centerline. Used for quick custom lathe tools, burring tools, and other types of special tools.



REF. # 55367

This special radius formed milling cutter was used to radius the edge of a customers part.



REF. # 55368

Here is another example of a special radius cutter to form a customers part.



REF. # 50530

Here is a special rivet shaver use in the aircraft industry for removing old rivets off aircrafts.



REF. # 53690

This large special end hollow mill was use to form a part for a plastic injection mold machine.



REF. # 50148

This special router-bit was made to put a special form on the edge of a customers part.



REF. # 51585

Slotting cutters can be made in a variety of diameters and widths to fit special needs.



REF. # 55369

Specialty countersinks can be made to do an array of countersinking needs. Can be made for sizing and chamfering special wheel bolt holes and lug nuts.



REF. # 54479

This specialty cutter was used by the military for a special gun lug applications and gun sights. A larger tool was used for cruise control arm lever hole.



REF. # 50661

This is a special spiraled end mill made for the oil drilling industry.

These are considered special items and are not returnable for credit



Phone: 989-777-5500 Fax: 989-777-0602

E-Mail: severancetool@sbcglobal.net

Severance Tool Industries Inc. • POB 1866 • Saginaw, MI 48605

Some examples of specials and their uses



REF. # 55370
Special stop-countersinks can be ordered in a variety of diameters, angles, pilot sizes, and thread sizes.



REF. # 52012
Here is a shell mill made by Severance to a customers print.

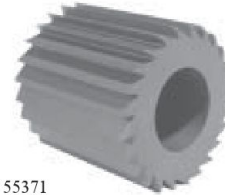

REF. # 55371
Milling cutters can be made with both special sizes and special flute configurations to meet customers needs.



REF. # 53260
Here is an example of a special taper reamers to taper the inside of a hole. Used on spindles and torches.



REF. # 50916
Here is an example of a special router bit with a bearing on the end in a router made for deburring the inside of plastic pipe.

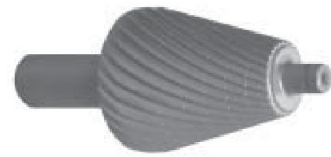

REF. # 50916
Here is the cutter used in the router to the left. A bearing is put on the end of this cutter to use as a guide. The tool bevels the inside of PVC tubing.

WB-Wood Burrs™

REF.#54884

Severance Tool developed WB-Wood Burrs™ that are Midget Mills® made with a special cut for the carving of wood. Different shapes and sizes can be made with this style of cut.

fine cut

medium cut

coarse cut

REF. # 53260

Severance has even made float files for equestrian use on horse teeth. The blades go into a float handle to be used to file down uneven horse teeth.

These are considered special items and are not returnable for credit

Severance Tool Industries, Inc.
Manufactures Code 662018
Website: www.severancetool.com



Phone: 989-777-5500 Fax: 989-777-0602

E-Mail: severancetool@sbcglobal.net

Severance Tool Industries Inc. • POB 1866 • Saginaw, MI 48605

Severance[®] Tool Industries, Inc.
Special Product Quotation Request

New Quote # _____
Old Quote # _____

Salesperson: _____
Computer #: _____
Date of Inquiry: _____
Complete Engineering: _____
Sales Response Date: _____
Follow-Up: _____

Distributor Data:

Company: _____
Address: _____
City/State/Zipcode: _____
Contact: _____
Phone: _____
Cell Phone: _____
Fax: _____

End-User Data:

Company: _____
Address: _____
City/State/Zipcode: _____
Contact: _____
Phone: _____
Cell Phone: _____
Fax: _____

Application:

Machine Held: _____ Coolant: _____
Hand Held: _____ Dry: _____
Curently Used: _____
Unit: _____

Material to be Machined:

Stainless Steel: _____ Specific Type: _____
Wood: _____
Plastic: _____
Aluminum: _____
Other: _____
Work Hardening: _____

Quantity & Discription:

Quantity: 1 2 5 10 25 50 100 250 _____
Type of Tool: _____
Second Tool: _____
Third Tool: _____
Over All Length: _____
Length of Cut: _____
Number of Flutes: _____
Angle: _____ C/L or Included
Shank: _____
Straight: _____ Diameter: _____
Threaded: _____ Threads: _____
Tapered: _____ Taper: _____
Additional Information: _____

Material of Item:

4140: _____
M-2: _____
M-42: (cobalt): _____
C-2(Tungesten Carbide): _____
Other: _____
Rockwell Desired: _____

Coatings:

Black Oxide: _____
TIN Coating: _____
TIALN Coating: _____
Diamind Grit: _____
Other: _____

Drawing or Sketch:



Phone: 989-777-5500 Fax: 989-777-0602

E-Mail: severancetool@sbcglobal.net

Severance Tool Industries Inc. • POB 1866 • Saginaw, MI 48605

Numerical Index

EDP Numbers	Tool Name	Page No.	EDP Numbers	Tool Name	Page No.
00245-00249	Ball Nose Deburring Cutters, HSS	27	17470-17563	Electrode Forming Cutters, HSS	46 thru 48
00250-00258	Bore-Mills™, Carbide	29	19720-19758	CBN -Boron Hand Files	71 thru 76
00270-00377	Single Flute Countersinks, HSS	62	19770-19894	Carbide Hand Files	71 thru 76
00420-00535	Single Flute Countersinks, Carbide	62	19970-20026	Diamond Hand Files	71 thru 76
00536-00583	Single Flute Double Ended Countersinks, HSS	61	20070-20194	Steel Hand Files	71 thru 76
00600-00648	Single Flute Double Ended Countersinks, Carbide	61	20470-20528	Inside Chamfering Mills, HSS	35
00970-01095	Econo-Sinks® (4 Flute Chatter-Free®), HSS	60	20470-20528	Multi-Flute Countersinks, HSS	56
01120-01203	Econo-Sinks® (4 Flute Chatter-Free®), Carbide	60	20620-20710	Inside Deburring Cutters, Carbide	33
01204-01251	Econo-Sinks® Double Ended (4 Flute Chatter-Free®), HSS	61	20770-20828	Inside Deburring Cutters, HSS	32
01252-01299	Econo-Sinks® Double Ended (4 Flute Chatter-Free®), Carbide	61	21120-21129	Micro-Mills™, Carbide	29
01470-01554	3N1® Drill Point Countersink, HSS	58	21220-21223	Micrometer Stop-Countersink Units	64
01585-01642	3N1® Drill Point Double Ended Countersink, HSS	57	21720-21742	Ecarno-Mills™ - 3/32" Shank, Carbide	24
01650-01717	3N1® Drill Point Double Ended Countersink, Carbide	57	21770-21798	Ecarno-Mills™ - 1/8" Shank, Carbide	23
01903-02013	3N1® Drill Point Countersink, Carbide	58	21920-21937	Ecarno-Mills™ - 3/16" Shank, Carbide	22
02370-02487	Six Flute Chatterless-Countersinks™, HSS	50	22150-22157	Di-Car Mills™, Carbide	30
02520-02635	Six Flute Chatterless-Countersinks™, Carbide	50	22149-22164	d-burr™, Carbide	28
02670-02752	Six Flute Double Ended Chatterless-Countersinks™, HSS	51	22180-22198	Carbo-Mills™ - 3/32" Shank, Carbide	24
02820-02902	Six Flute Double Ended Chatterless-Countersinks™, Carbide	51	22230-22249	Carbo-Mills™ - 1/8" Shank, Carbide	23
02970-03026	CNC-K™ Precision Chatterless-Countersinks™, HSS	53	22280-22298	Carbo-Mills™ - 3/16" Shank, Carbide	22
03120-03176	CNC-K™ Precision Chatterless-Countersinks™, Carbide	54	22380-22592	Carbo-Mills™-1/4" Shank, Carbide	4 thru 21
03177-03224	CNC-K™ Precision Double Ended Chatterless-Countersinks™, HSS	53	22620-22673	Lab Mills, HSS	26
03423-03470	CNC-K™ Precision Double Ended Chatterless-Countersinks™, Carbide	54	22720-22747	Junior Mills®, HSS	25
03270-03328	Six Flute Threaded Chatterless-Countersinks™, HSS	51	22820-22847	Junior Mills®, Carbide	25
03572-03651	AC-Adjustable Countersinks, HSS	63	22850-22871	Junior d-burrs™, Carbide	28
03920-03973	Heavy Duty Chatterless-Countersinks™, HSS	52	22930-23237	Midget Mills®, HSS	4 thru 21
13840-14483	Stop-Countersink Cutters, Carbide	66,67	23280-23424	Midget Mills®, Carbide	4 thru 21
15340-15993	Stop-Countersink Cutters, HSS	65,66	23680-23710	Sever-Cuts™, Carbide	4 thru 21
15349-15973	3N1-QC™ Quick Change Drill Point Countersinks	59	23730-23756	Midget Mills®, 8" Shank, HSS	21
17260-17290	Die Mills, Carbide	30	23780-23806	Midget Mills®, 8" Shank, Carbide	21
17310-17326	Die Mills, HSS	30	25140-25152	HR-Hole Radius Deburring Cutters, HSS	43
17360-17374	Disc Cutters, HSS	45	25230-25257	Outside Chamfering Mills, HSS	36
17420-17435	Edge Deburring Tools, HSS	45	25430-25470	Outside Deburring Cutters, HSS	33
			26030-26038	Ball Seat Reamers, HSS	69
			26130-26135	Micro-Center™ Reamers, Carbide	70
			26170-26174	Micro-Reamers™, Carbide	70
			26480-26548	Drill Reamers, HSS	69
			28480-28498	Rivet Shavers, Carbide	67
			28630-28644	Rod End Forming Cutters, HSS	44
			28685-28756	Carbo-Routs™, Carbide	68
			29570-29695	Sets	81 thru 86
			34060-34265	Shanks-HSS	78 thru 80
			34266-34272	Whirly-Gig®, Speedy Handle™	41, 80, 86
			34310-34327	Extra Length Lab Mills®, HSS	27
			34960-34982	Tube End Chamfering Mills, HSS	37
			35060-35078	Tube End Deburring Cutters, HSS	34
			35160-35170	Tube End Deburring Cutters, Carbide	34
			35460-35559	Tube End Forming Cutters, HSS	38 thru 40
			35579-35585	Tube End Forming Cutters - EMT, HSS	40
			35660-35671	Tube Hole Deburring Cutters, HSS	16, 40
			36180-36195	End Mills, Carbide	68
				Special Tool Examples	91 thru 97

Severance™ Tool Industries, Inc.
Manufactures Code 662018
Website: www.severancetool.com

Severance[®] Tool Industries, Inc.

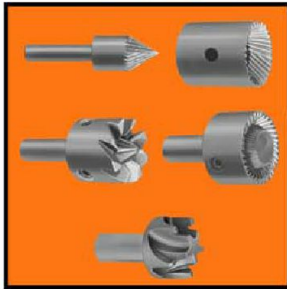

Tube Deburring Tools
 These tools are designed to either deburr, chamfer, or form the end of tubing. A variety of tools and sizes to do inside or outside or both inside and outside diameters are available. Also Special Diameters, Forms, and angles are available.



Chatterless-Countersinks[™]
 Severance Tool originated the Chatterless-Countersinks[™], the Chatter-free[®] Countersinks, and the precision CNC-K[™] Chatterless-Countersinks[™]. We also manufacture Heavy Duty Chatterless-Countersinks[™], Single Flute countersinks, and Multi-Flute finishing countersinks. We are known for our custom designed countersinks, with special angles and sizes to your part requirements.



Micrometer Stop-Countersink Units, Widely used the Aircraft and transportation industry for exact control. The patented Severance Micrometer Stop Unit features an easy to use micrometer like depth control setting. Severance Micro Stop countersinks available in High Speed Steel or Carbide which features our Chatter-free[®] flute design for fast production, quick chip removal and smooth finishes.



Midget Mills[®]
 Severance Tool originated the ground flute Midget Mills[®] and the ground flute rotary files. We are known for our "Ground from the solid" after heat treat finishing tools. These tools are available in a wide range of styles and sizes. Midget Mills[®] are used for precision finishing, milling, and deburring applications.



Carbide Hand Files
 Also known as flat files. Widely used in Die finishing, aircraft components, and similar very hard materials.

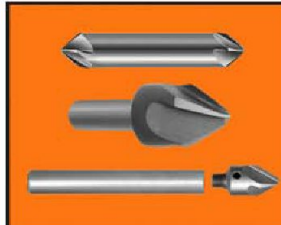

3N1[™] and QC-Countersinks[™]
 Severance Tool has developed a unique tool, the 3N1[™] tool which combines the functions of a drill point, a countersink, and an edge chamfer. Severance QC-Countersinks[™] and QC-3N1[™] tools save change over times, reduce tooling costs, and also feature available long and extra long shank sizes for reaching around fixtures or into parts.



Small Diameter Midget Mills[®]
 These tool are designed for fast precision finishing in small or confined applications.



Unique Tools
 Severance Tool offers a variety of unique tools to solve customer applications and problems. Some of these are Chatterless[™] Ball Seat Reamers, Electrode Dressing Cutters, and Rod End Forming Cutters.



Specials
 Severance Tool does a wide variety of altered standards and made to print cutters. Severance Tool has prints of specials dating all the way back to the 1930's. We would be glad to quote your special cutting tool needs.

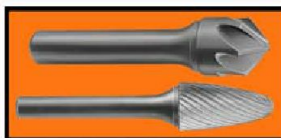

Resharping Service
 Severance does a complete regrind service of our tools. This is an economical way to extend the life of a tool, and lower your tooling costs.

Over 75 Years of Quality Tool Manufacturing in Saginaw, Michigan USA



Severance[®]

Tool Industries Inc.

3790 Orange St, P.O. Box 1866

Saginaw, Michigan 48605

Phone: 989-777-5500

Fax: 989-777-0602

Website: www.severancetool.com

Copyright © 2011 Severance Tool Ind. Inc.