



GLOSSARY OF TERMS
RELATING TO VALCO^{fi} SNAP-BUTTONS

MATERIAL ALL VALCO^{fi} SNAP-BUTTONS are made from 1050 Spring Steel, heat treated, unless otherwise noted.

VALCO^{fi} SNAP-BUTTONS with an (X) as a suffix are made from 410 Stainless Steel, e.g. A-130-X

Certain VALCO^{fi} SNAP-BUTTONS can be furnished in 300 Series Stainless Steel assemblies. (See II, JJ, KK)

PLATING All VALCO^{fi} SNAP-BUTTONS are Zinc Plated .0051 minimum, unless otherwise noted.

For items plated otherwise:

- Specify -B for Black Zinc finish
- G for Zinc/Gold Dichromate finish
- N for Nickel plated finish, e.g. A-103-N

For prices, please consult Sales Department.

STIFFENER  Edges of material on Button leg are formed at approx. 45° chamfers to reduce flexing.

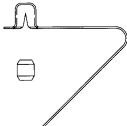
(S)  As a suffix indicates a solid steel insert is crimped in the Button Head. e.g. A-130-S

(X) As a suffix indicates that part is available in 410 Stainless Steel, e.g. A-130-X

(R) As a prefix indicates a solid contoured one-way ramp is riveted securely to a VALCO^{fi} spring. e.g.

 RR-160 - Contoured one-way ramp riveted to a single end straight spring leg. Please consult Sales Department.

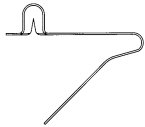
DOME HEAD  Has a spherical radius on top of the button head, as opposed to a flat surface on a standard VALCO^{fi} SNAP-BUTTON head. It can be furnished on special order in production quantities. Please contact Sales Department.

Specifications subject to change without notice.



Made exclusively by VALCO^{fi} VALLEY TOOL & DIE, INC.

10020 York Theta Drive, North Royalton, Ohio 44133

(440) 237-0160 Fax (440) 237-0089 Website: <http://www.valcocleve.com>

VALCO^{fi} A, B, D, and E Style snap - buttons eliminate the need for rivets and screws. Also, they can simplify assembly of your products.

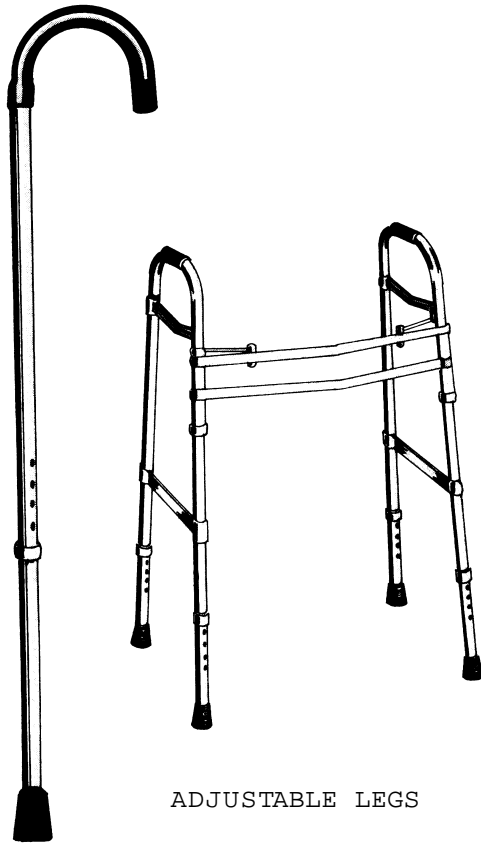

FOR BEST RESULTS IN THICK WALL TUBING, DRILL THRU AND RECESS TUBE WALL WITH 25.40 BALL MILL

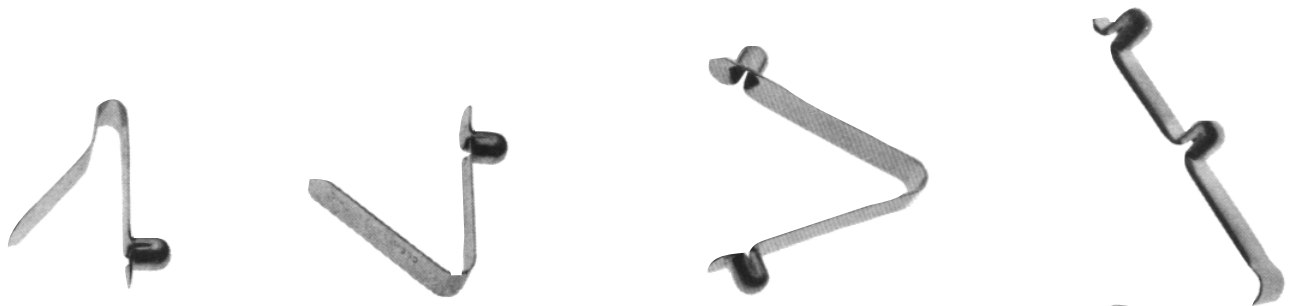
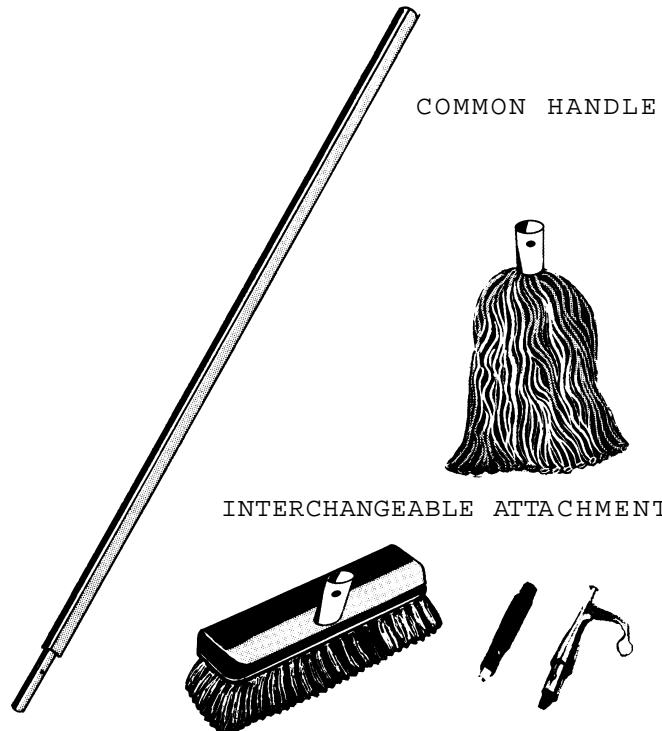
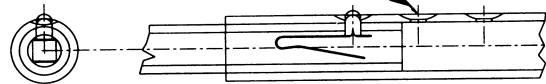

Made exclusively by VALCO^{fi} VALLEY TOOL & DIE, INC.

10020 York Theta Drive, North Royalton, Ohio 44133

(440) 237-0160 Fax (440) 237-0089 Website: <http://www.valcocleve.com>

VALCO^{fi} SNAP-BUTTON

A - SINGLE END

- STRAIGHT

SPRING LEG

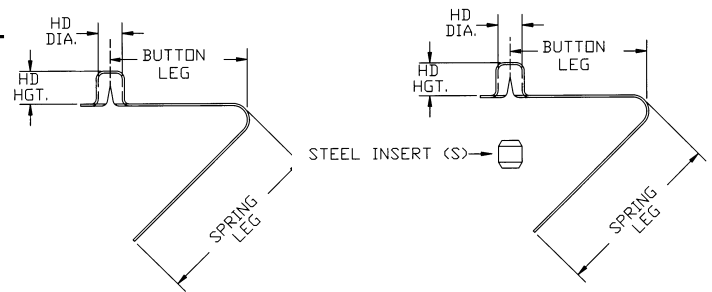

P/N	OLD P/N	HD. DIA.	HD. HGT.	MATERIAL SIZE	FEATURES	TUBING I.D.	
						ROUND	SQUARE
A-050		3.18	4.06	.30x4.32		6.1/11	5/11
A-051		3.18	4.06	.30x4.32	Stiffener	6.1/11	5/11
A-070		3.96	7.37	.46x5.33	Dome Head	10.2/16.5	9.4/16.5
A-071		3.96	7.37	.46x5.33	Dome Head	13/31.5	13/31.5
A-072		3.96	5.21	.46x5.33	Dome Head	9.4/16.5	8/16.5
A-100		4.75	6.10	.46x6.48		11/15.5	9.4/15.5
A-101		4.75	6.10	.46x6.48	Small V	8.2/12.5	8/11
A-101-D		4.75	6.10	.46x6.48	Dome Head	8.2/12.5	8/11
A-102		4.75	5.33	.46x5.59		9.4/19	8/19
A-103		4.75	7.11	.46x6.48		9.2/12.5	9/11
A-104		4.75	6.10	.46x6.48	1 Short Leg	13/16.5	13/16.5
A-105		4.75	10.92	.46x6.60	Dome Head	14.3/20	13.5/20
A-107		4.75	9.14	.46x5.72	Stiffener	14.3/20	13/20
A-110	(0116-219-22)	5.56	5.59	.46x8.26		10.5/15.5	8.2/15.5
A-111	(0116-219-28)	5.56	7.11	.46x8.26		11/19	10.2/19
A-112	(0116-219-30)	5.56	7.62	.46x8.26	W/Stiffener	11/15.5	10/15.5
A-113	(0173-219)	5.56	7.37	.46x8.26	Small V	10.2/11	10.2/11
A-114		5.56	5.33	.38x8.26	20.83 Spring Leg	9.4/12.5	6.4/11
A-115		5.56	7.62	.46x8.26	Small V	9.4	9.4/9.4
A-116		5.56	7.11	.46x8.26	Small V	9.4/15.5	9.4/15.5
A-117		5.56	5.59	.46x8.26	10 Bend By Head	14.3/22	14.3/22
A-118		5.56	5.59	.46x8.26	Small V	14.3/22	14.3/22
A-119		5.56	9.02	.46x8.26		16.6/22	13/22
A-120	(0116-240-28)	6.00	7.11	.46x8.89		11.5/22	11/22
A-120-X	(0116-240-28-X)	6.00	7.11	.46x8.89		11.5/22	11/22
A-121	(0183-240-39)	6.00	9.91	.64x8.51	47.50 Spring Leg	13/31.5	11.5/31.5
A-122*		6.35	9.91	.64x9.02		20.4/35	20.4/35
A-130	(0116-250-28)	6.35	7.11	.46x9.27		11.5/22	11/22
A-230		6.35	5.59	.46x9.27	43.18 Legs	11.2/15.5	8x15.5
A-130-X	(0116-250-28-X)	6.35	7.11	.46x9.27		11.5/22	11/22
A-130-S	(0116-250-28-S)	6.35	7.11	.46x9.27		11.5/22	11/22
A-131*	(0135-250-28)	6.35	7.11	.51x9.27		17/34.5	15/34.5
A-231		6.35	7.11	.46x9.27	Small V	9.4/15.5	9.4/15.5
A-132	(0135-250-T)	6.35	7.11	.64x8.89		18/34.5	15.3/34.5
A-232-X		6.35	4.83	.46x9.27	Dome Head	9.4/15.5	9.4/15.5
A-233		6.73	7.62	.51x9.27		13/31.5	13/31.5
A-134	(0183-250-39)	6.35	9.91	.46x9.27	47.50 Spring Leg	13/31.5	11/31.5
A-134-S		6.35	9.91	.46x9.27		13/31.5	11/31.5
A-134-X		6.35	9.91	.46x9.27		13/31.5	11/31.5
A-134-X-S		6.35	9.91	.46x9.27		13/31.5	11/31.5
A-234		6.35	7.92	.46x9.27	Short Legs	15.3/17.5	11.2/14
A-135*	(0214-250)	6.35	7.11	.64x8.89	47.50 Spring Leg	22.1/34.5	22.1/34.5
A-235*		6.35	9.91	.46x9.27	Large Radius	22.1/34.5	19.1/31.5
A-136		6.35	7.11	.46x9.27	23.88 Legs	13/17	11/17
A-137		6.35	9.40	.46x9.27	23.88 Legs	13/17	11/17
A-138		6.35	7.11	.46x8.89	23.88 Legs	13/17	11/17
A-139		6.35	7.11	.64x8.89	60.20 Legs	28/44	28/44
A-140	(0116-302-37)	7.67	9.40	.51x11.18		15/31.5	12.5/31.5
A-140-X	(0116-302-37)	7.67	9.40	.51x11.18		15/31.5	12.5/31.5
A-140-S	(0116-302-37-S)	7.67	9.40	.51x11.18		15/31.5	12.5/31.5
A-143		7.67	9.40	.51x11.18	W/Stiffener	15/31.5	12.5/31.5
A-144		7.67	8.13	.51x11.18	Short Legs	14.3/16.5	12/14

*are for 9.5 x 34.8 I.D. Rectangular Tube
CONTINUED ON PAGE 4

ALL VALCO^{fi} SNAP-BUTTONS are 1050 Spring Steel and .0051 Zinc Plated minimum, unless otherwise noted.

For items plated otherwise:

Specify: -B for Black Zinc finish

-N Nickel plated finish, e.g. A-130-N

-G for Zinc/Gold Dichromate finish

-D = Dome Head

-S = Standard item with steel insert crimped in button head

-X = Standard item in 410 Stainless Steel



Made exclusively by VALCO^{fi} VALLEY TOOL & DIE, INC.

10020 York Theta Drive, North Royalton, Ohio 44133

(440) 237-0160 Fax (440) 237-0089 Website: <http://www.valcocleve.com>

VALCO^{fi} SNAP-BUTTON

A - SINGLE END
 - STRAIGHT
 SPRING LEG

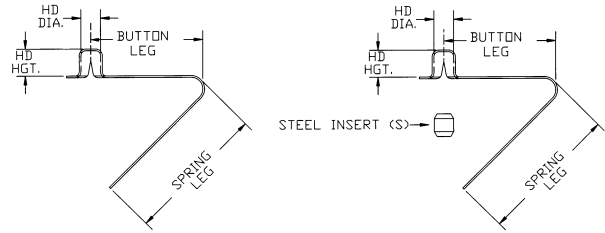

P/N	OLD P/N	HD. DIA.	HD. HGT.	MATERIAL SIZE	FEATURES	TUBING I.D. S	
						ROUND	SQUARE
A-145		7.67	9.53	.64x10.67		17.3/34.5	14/34.5
A-146		7.67	8.13	.38x10.67	Short Leg	15/31.5	13/31.5
A-150	(0116-312-37)	7.92	9.40	.51x11.18		15/31.5	12.5/31.5
A-150-S	(0116-312-37-S)	7.92	9.40	.51x11.18		15/31.5	12.5/31.5
A-151	(0140-312-50)	7.92	12.70	.51x11.18	55.12 Spring Leg	17.3/38	16/38
A-151-D		7.92	12.70	.51x11.18	Dome Head	17.3/38	16/38
A-152-X		7.92	11.18	.51x11.18	Square Ends	16/31.5	15/31.5
A-153	(A-150-D)	7.92	9.40	.51x11.18	Dome Head	15/31.5	12.5/31.5
A-154		7.92	6.86	.51x11.18	Short Leg	15/25	13/25
A-155		7.92	12.70	.51x11.18		25.4/38	22.1/38
A-160	(0116-365-31)	9.27	7.87	.64x12.95		15.3/34.5	13.3/34.5
A-260		9.27	11.18	.64x12.95	Dome Head	28/38	22.1/38
A-260-X		9.27	11.18	.64x12.95	Notched(46.99) Leg	28/38	22.1/38
A-161	(0116-365-37)	9.27	9.40	.64x12.95		17.3/34.5	13.3/34.5
A-161-X	(0116-365-37)	9.27	9.40	.64x12.95		17.3/34.5	13.3/34.5
A-161-S	(0116-365-37-S)	9.27	9.40	.64x12.95		17.3/34.5	13.3/34.5
A-261		9.27	11.18	.64x12.95	DM HD/SM/V	16/28	16/28
A-162	(0116-365--.530)	9.27	9.40	.64x13.46		18/34.5	14.3/34.5
A-262		9.27	9.40	.64x12.95	Dome Head	22.1/47.5	22.1/47.5
A-163	(0116-365-44)	9.27	11.18	.64x12.95		18/34.5	14.5/34.5
A-163-D		9.27	11.18	.64x12.95	Dome Head	18/34.5	14.5/34.5
A-263-D		9.27	11.18	.51x12.95	Dome Head	19.1/38	19.1/38
A-164	(0196-365)	9.27	9.40	.64x13.46	W/Stifener	38.1/63.5	38.1/63.5
A-165	(0227-365)	9.27	9.40	.64x12.95	50.80 Spring Leg	19.1/25	16/25
A-165-S	(0227-365-S)	9.27	9.40	.64x12.95	50.80 Spring Leg	19.1/25	16/25
A-166	(0122-365)	9.27	9.40	.64x12.95	60.20 Button Leg	19.1/34.5	13.3/34.5
A-167	(0122-365-ST)	9.27	9.40	.64x12.95	W/Stifener	19.1/34.5	13.3/34.5
A-267		9.27	9.40	.64x12.95	Stifener	13/38	13/38
A-168	(0116-365-56)	9.27	14.22	.64x12.95		20.4/38	20.4/38
A-169	(0116-365-31)	9.27	7.87	.64x12.95	Dome Head	15.3/34.5	13.3/34.5
A-170		9.27	9.40	.64x13.46		32/44	28.5/44
A-170-S		9.27	9.40	.64x13.46		32/44	28.5/44
A-171		9.27	9.40	.64x12.95		18/38	16/38
A-172		9.27	12.70	.64x13.46		32/44	28.5/44
A-173		9.27	12.70	.51x12.95	Light Touch(45.72 Leg)	23/47.5	22.1/47.5
A-174		9.27	14.22	.51x12.95	Light Touch	25.4/38	25.4/38
A-175		9.27	14.22	.51x12.95	Light Touch	24.2/35.5	24.2/35.5
A-176		9.27	7.87	.64x12.95	Small V	16/24	16/24
A-180	(0116-375-37)	9.53	9.40	.64x12.95		18/34.5	14/34.5
A-181	(0122-375)	9.53	9.40	.64x12.95	60.20 Button Leg	19.1/34.5	13.3/34.5
A-182	(0140-375)	9.53	9.40	.64x12.95	41.40 Button Leg	18/38	15/38
A-183	(0230-375)	9.53	6.35	.64x13.46	35.56Legs DomeHead	13/25	13/25
A-184		9.53	9.40	.51x12.95	Short Legs	19.1/25	19.1/25
A-185		9.53	10.29	.64x13.46	Small V	22/38	22/38
A-190	(0119-500-56)	12.70	14.22	.76x17.27		29/57	21/57
A-191		12.75	14.22	.76x17.27	Sheared Tab	29/57	21/57
A-192	(0119-500-59)	12.70	14.99	.76x17.27		29/57	22.1/57
A-192-S	(0119-500-59S)	12.70	14.99	.76x17.27		29/57	22.1/57
A-193		12.70	13.97	.76x17.27	Dome Head	28/57	22.1/57
A-194		12.70	14.99	.76x17.27	Double Stifener	28/57	22.1/57

ALL VALCO^{fi} SNAP-BUTTONS are 1050 Spring Steel and .0051 Zinc Plated minimum, unless otherwise noted.

For items plated otherwise:

- Specify: -B for Black Zinc finish
 -G for Zinc/Gold Dichromate finish
 -N Nickel plated finish, e.g. A-130-N
- D = Dome Head
 -S = Standard item with steel insert crimped in button head
 -X = Standard item in 410 Stainless Steel



Made exclusively by VALCO^{fi} VALLEY TOOL & DIE, INC.

10020 York Theta Drive, North Royalton, Ohio 44133

(440) 237-0160 Fax (440) 237-0089 Website: <http://www.valcocleve.com>

Rev. 02/00

VALCO^{fi} SNAP-BUTTON

B - SINGLE END - DOG LEG

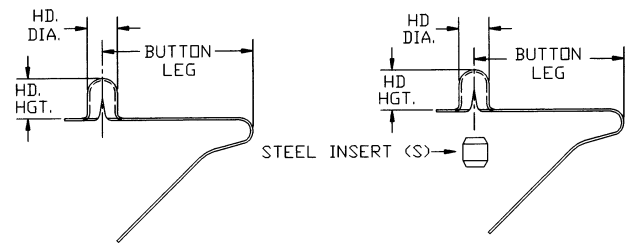

P/N	OLD P/N	HD. DIA.	HD. HGT.	MATERIAL SIZE	FEATURES	TUBING I. D. S	
						ROUND	SQUARE
B-100	(0123-187-.23)	4.75	5.84	.46x6.60		9/19	8/19
B-100-X	(0123-187-23-X)	4.75	5.84	.46x6.60		9/19	8/19
B-100-S	(0123-187-23-S)	4.75	5.84	.46x6.60		9/19	8/19
B-101	(0195-187-23)	4.75	5.84	.46x6.60	35.56 Btn. Leg	9/19	8/19
B-101-S	(0195-187-23-S)	4.75	5.84	.46x6.60	35.56 Btn. Leg	9/19	8/19
B-102-S	(0123-187-SPF)	4.75	6.35	.46x6.60	W/Stiffener	9/19	8/19
B-103		4.75	6.35	.46x6.60	Dome Head	9/19	8/19
B-104		4.75	7.11	.46x6.60	Dome Head	9.4/20.5	9.4/20.5
B-104-X		4.75	7.11	.46x6.60	Dome Head	9.4/20.5	9.4/20.5
B-111	(0123-219-29)	5.56	7.37	.46x8.26		11.5/20	9.4/20
B-120	(0123-240-29)	6.00	7.37	.46x8.89		13/20	9.4/20
B-121	(0123-240-32)	6.00	8.13	.46x8.89		13/20	10.2/20
B-122	(0123-240-39)	6.00	9.91	.46x8.89		13/17.5	11.5/17.5
B-123		6.00	9.91	.46x8.89	Long Tab	16/20.5	16/20.5
B-130	(0123-250-28)	6.35	7.11	.46x9.27		11.5/20	9.4/20
B-130-X	(0123-250-28)	6.35	7.11	.46x9.27		11.5/20	9.4/20
B-130-S	(0123-250-28-S)	6.35	7.11	.46x9.27		11.5/20	9.4/20
B-131	(0123-250-28)	6.35	7.11	.46x9.27	W/Stiffener	11.5/20	9.4/20
B-131-S	(0123-250-28)	6.35	7.11	.46x9.27	W/Stiffener	11.5/20	9.4/20
B-132	(0123-250-28)	6.35	7.11	.46x9.27	Smaller Form	11/20	9.4/20
B-134		6.35	9.91	.51x8.89		14/25	14/25
B-134-D		6.35	9.91	.51x8.89	Dome Head	14/25	14/25
B-135		6.35	7.11	.46x9.27	25.40 Spring Legs	10/15.5	10/15.5
B-140	(0123-302-32)	7.67	8.13	.51x11.18		13.3/25	11.5/25
B-141	(0123-302-37)	7.67	9.40	.51x11.18		14/25	11.5/25
B-141-X	(0123-302-37)	7.67	9.40	.51x11.18		14/25	11.5/25
B-141-S	(0123-302-37-S)	7.67	9.40	.51x11.18		14/25	11.5/25
B-142	(0123-302-30)	7.67	7.62	.51x11.18	Dome Head	13/25	9.4/25
B-142-X	(0123-302-30-X)	7.67	7.62	.51x11.18	Dome Head	13/25	9.4/25
B-143		7.67	8.26	.51x11.18	Short Spg. Leg	16/25	13.3/25
B-144-D		7.67	12.70	.51x11.18	Dome Head	19.1/25	18/25
B-145		7.67	15.88	.51x11.18		19.1/25	18/25
B-145-D		7.67	15.88	.51x11.18	Dome Head	24.2/28	22.1/28
B-150	(0123-312-37)	7.92	9.40	.51x11.18		14/25	11.5/25
B-255		8.38	9.40	.64x12.45		17.8/21	17.8/21
B-160	(0123-365-37)	9.27	9.40	.64x12.95	Button Leg:	15.3/28	13.3/28
B-160-X	(0123-365-37)	9.27	9.40	.64x12.95	45.72	15.3/28	13.3/28
B-160-S	(0123-365-37-S)	9.27	9.40	.64x12.95	Spring Leg	15.3/28	13.3/28
B-161	(0123-365-44)	9.27	11.18	.64x12.95	53.85	15.3/28	13.3/28
B-162	(0123-365-28)	9.27	7.11	.64x12.95		15.3/28	13.3/28
B-163		9.27	9.53	.64x12.95	Small Radius in V	16/22	16/15.5
B-170		9.27	9.40	.64x13.46		23/49.5	23/49.5
B-172		9.27	12.70	.64x13.46	Dome Head	25.4/49.5	25.4/49.5
B-180	(0123-375-37)	9.53	9.40	.64x12.95		16/28	13.3/28
B-180-X	(0123-375-37)	9.53	9.40	.64x12.95		16/28	13.3/28
B-201		10.85	12.70	.64x15.24	Dome Head	19.1/29	17.3/29.5
B-200		11.05	7.87	.64x15.88		18/38	16/34.5
B-202		11.10	10.67	.64x15.88		20.4/38	17/38
B-190	(0123-500-62)	12.70	15.75	.76x17.27		32/47.5	28.5/47.5
B-191	(0123-500-NV)	12.70	15.75	.76x17.27	W/Stiffener	25.4/41	22.1/41
B-191-S	(0123-500-SNV)	12.70	15.75	.76x17.27	W/Stiffener	25.4/41	22.1/41
B-210		12.70	10.67	.76x17.27		23/43	19.1/43
B-211		12.70	10.67	.76x17.27	Notched Spring	23/43	19.1/43

ALL VALCO^{fi} SNAP-BUTTONS are 1050 Spring Steel and .0051 Zinc Plated minimum, unless otherwise noted.

For items plated otherwise:

Specify: -B for Black Zinc finish

-N Nickel plated finish, e.g. B-130-N

-G for Zinc/Gold Dichromate finish

-D = Dome Head

-S = Standard item with steel insert crimped in button head

-X = Standard item in 410 Stainless Steel



Made exclusively by VALCO^{fi} VALLEY TOOL & DIE, INC.

10020 York Theta Drive, North Royalton, Ohio 44133

(440) 237-0160 Fax (440) 237-0089 Website: <http://www.valcocleve.com>

For unobstructed tube application try our C-TYPE VALCO^{fi} SNAP-BUTTONS

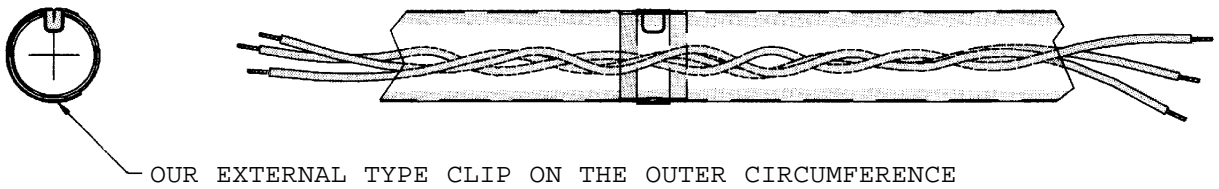
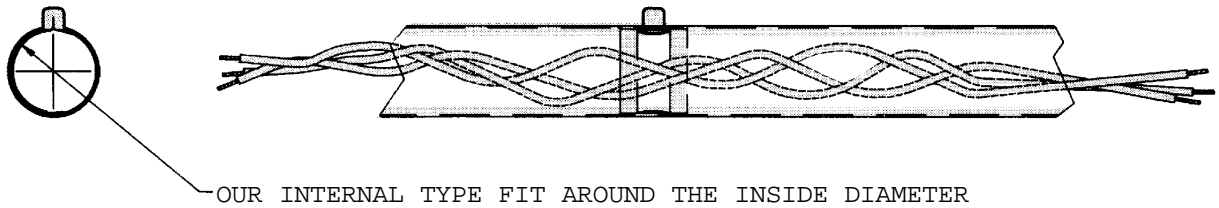

SOLID STEEL HEADS ARE ALSO AVAILABLE

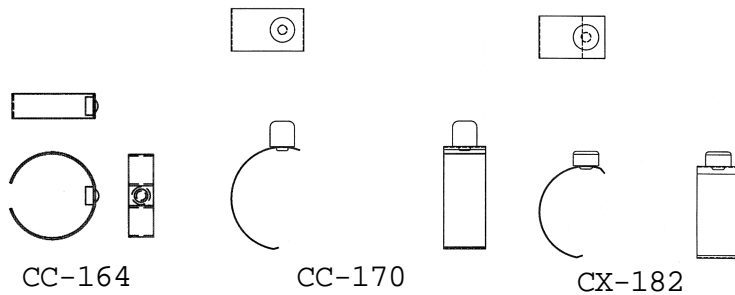

VALCO^{fi} SNAP-BUTTON

C-TYPE

P/N	OLD P/N	HD. DIA.	HD. HGT.	M ATERIAL SIZE	FITS TUBING I.D.
C-100		3.18	4.75	.25x6.10	19
C-110		4.75	4.83	.46x6.60	32
C-110-X	0133-187-1.2	4.75	4.83	.46x6.60	32
C-130	0133-250-.7	6.35	4.57	.31x9.27	19
C-230		6.35	7.87	.31x9.27	33
C-131	0133-250-.7	6.35	6.35	.31x9.27	19
C-231		6.35	6.35	.31x9.27	19/22
C-132	0133-250-.8	6.35	6.35	.31x9.27	22
C-232		6.35	6.35	.31x9.27	19
C-133		6.35	4.83	.31x9.27	22
C-133-X	0133-250-.8	6.35	4.83	.31x9.27	22
C-134		6.35	4.57	.31x9.27	29
C-134-X	0133-250-1.1	6.35	4.83	.31x9.27	29
C-234-X		6.35	5.21	.31x9.27	25.4
C-135	0133-250-1.2	6.35	4.83	.31x9.27	32
C-235-X		6.35	5.21	.31x9.27	33
C-136	0133-250-1.2	6.35	6.35	.31x9.27	32
C-137	0133-250-1.2	6.35	4.83	.31x9.27	32
C-137-X	0133-250-1.2	6.35	4.83	.31x9.27	32
C-138	0133-250-1.2	6.35	6.35	.46x9.27	32
C-139		6.35	6.35	.31x9.27	26/28
C-139-X		6.35	6.35	.31x9.27	26/28
C-180		9.53	9.40	.51x12.95	37
C-182		9.53	9.40	.46x13.46	51/54
C-233		6.27	5.08	.25x9.27	16
C-240		7.67	6.76	.76x17.27	51
C-250	0208-240-1.0	7.87	8.64	.31x11.18	32/38
C-251		.310	.34	.012/.625	1.25/1.50

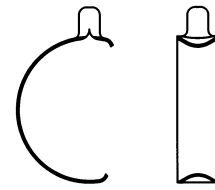

C-110/C-130

C-150	0208-219-1.2	5.56	6.35	.38x15.24	32
C-151	0208-219-1.5	5.56	6.35	.38x15.24	38
C-152	0208-240-1.0	6.10	6.35	.31x15.24	26
C-153		6.35	6.35	.31x12.70	26

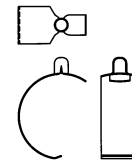

C-150/C-153

P/N	OLD P/N	HD. DIA.	HD. HGT.	M ATERIAL SIZE	FITS TUBING O.D.	FEATURES
CI-100-B	RD-1774-A	3.18	3.18	.46x4.32	13	Inverted Head
CI-101-B	RD-1774-B	3.18	3.81	.46x4.32	13	Inverted Head
CI-110	C-160	4.75	5.84	.46x6.60	22	Inverted Head
CI-111	C-163	4.75	5.59	.46x6.73	26	Inverted Head
CI-112	C-161	4.75	6.35	.46x6.60	32	Inverted Head
CI-131	C-164	6.35	7.11	.51x9.27	38	Inverted Head
CI-113	C-165	4.75	8.43	.46x6.48	45/48	Inv.Hd. w/Pull tab
CI-132	C-166	6.35	6.35	.51x9.27	38	Inverted Head
CI-133	C-167	6.35	6.35	.51x9.27	38	Inverted Head
CI-168	C-168	8.76	9.53	.38x11.18	32	Spec.Dimple Btn.

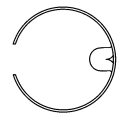

CI-110

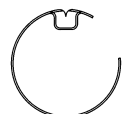

CI-130

P/N	OLD P/N	HD. DIA.	HD. HGT.	M ATERIAL SIZE	FITS TUBING I.D.	FEATURES
CX-130		6.35	4.83	.31x9.27	32	
CR-160		9.47	7.87	.31x15.88	32	Contour Ramp
CD-160		9.53(2x)	12.95(2x)	.64x13.46	109	Double Button
CC-120		3.96	3.76	.25x11.18	14	Min.Tool Bit Ret.
CC-164		4.78	2.41	.51x6.60	23 O.D.	Invert. Solid Btn.
CC-170		9.27	9.40	.31x15.88	33	SOLID STAINLESS
CC-180		9.53	9.40	.31x15.88	37	STEEL BUTTON
CX-182		9.53	5.46	.31x15.88	32	Solid Stainless

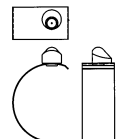

CR-160

ALL VALCO^{fi} SNAP-BUTTONS are 1050 Spring Steel and .0051 Zinc Plated minimum, unless otherwise noted.

For items plated otherwise:

Specify: -B for Black Zinc finish

-G for Zinc/Gold Dichromate finish

-N Nickel plated finish, e.g. C-130-N

-D = Dome Head

-S = Standard item with steel insert crimped in button head

-X = Standard item in 410 Stainless Steel



D-STYLE SNAP-BUTTONS provide a more positive and safe connection where assembly is required.

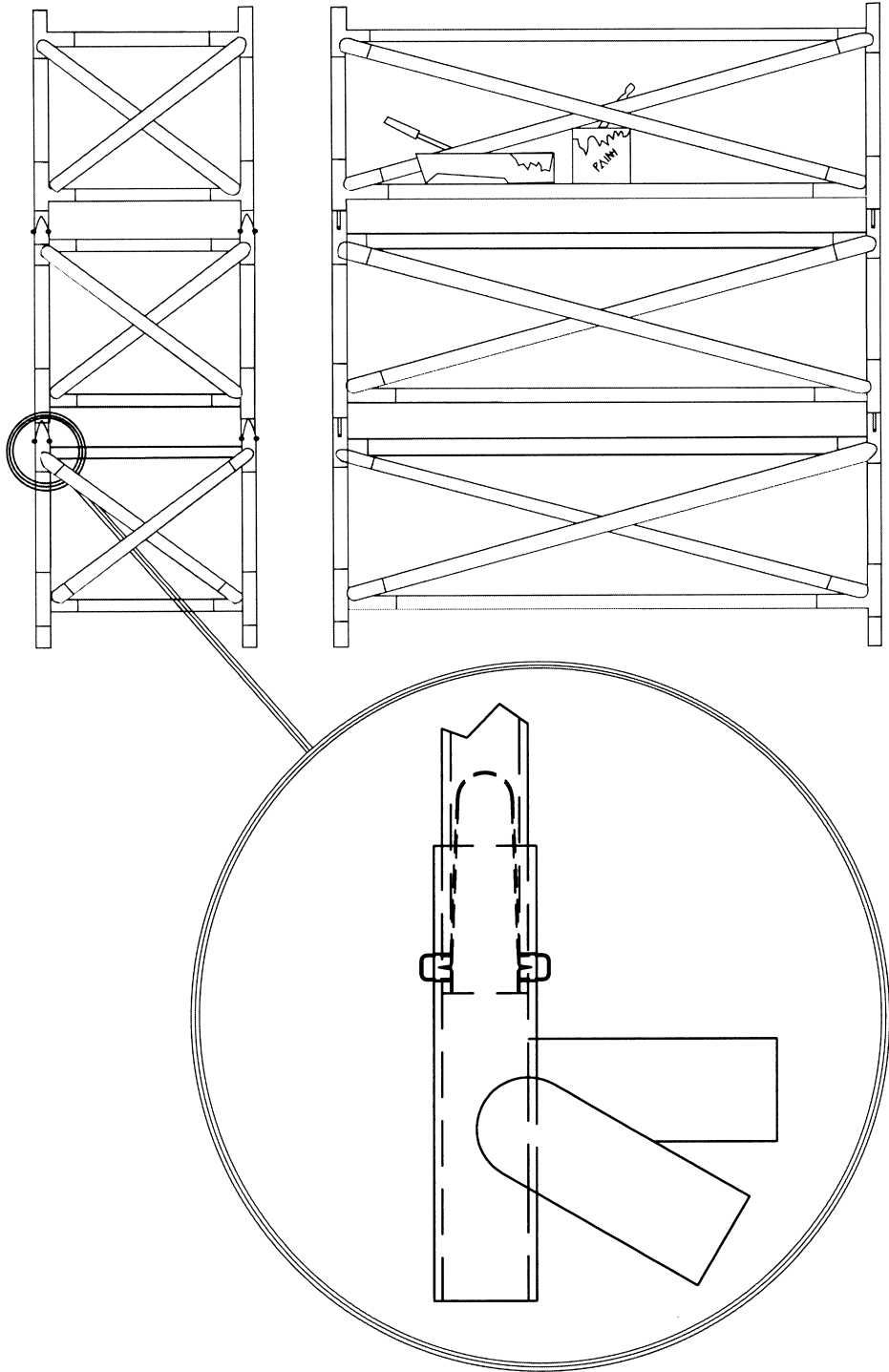

VALCO^{fi} SNAP-BUTTON D-DOUBLE END

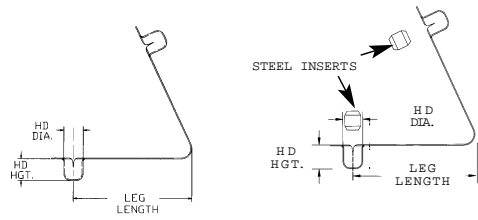

P/N	OLD P/N	HD. DIA.	HD. HGT.	M ATERIAL SIZE	LEG LENGTH	TUBING I.D. S	
						ROUND	SQUARE
D-050		3.18	3.56	.30x4.32	19.69	8/12.5	8/12.5
D-051		3.18	3.05	.30x4.32	11.43	10/12	10/12
D-100	(0117-187-M)	4.75	5.08	.46x6.60	33.02	13/22	13/22
D-101		4.75	5.08	.46x6.60	Dome Head	13/22	13/22
D-102		4.75	5.08	.46x6.60		13/22	13/22
D-104-X		4.93	7.24	.64x7.62	Dome Head	19.1/31.5	19.1/31.5
D-105		4.93	6.99	.64x7.62	Special	19.1/25	19.1/25
D-120		6.00	10.41	.64x8.89	139.70 Flat	48.3/82.5	48.3/82.5
D-120-X	(0215-240)	6.00	10.41	.64x8.89	Flat (No Bend)	48.3/82.5	48.3/82.5
D-120-S-X	(0215-240-S)	6.00	10.41	.64x8.89	Flat (No Bend)	48.3/82.5	48.3/82.5
D-121	(0234-240)	6.00	7.62	.64x8.51	36.07	38.1/41	35/38
D-122		6.00	7.14	.46x8.89	39.12	19.1/25	19.1/25
D-130	(0117-250-.012)	6.35	7.11	.30x9.27	38.61	16/22	16/22
D-131	(0117-250-.018)	6.35	7.11	.46x9.27	38.61	16/22	16/22
D-131-X	(0117-250-.018)	6.35	7.11	.46x9.27	38.61	16/22	16/22
D-131-S	(0117-250-.018S)	6.35	7.11	.46x9.27	38.61	16/22	16/22
D-132	(0117-250-.020)	6.35	7.11	.51x9.27	38.61	16/22	16/22
D-133	(0194-250)	6.35	7.11	.46x9.27	28.70	18/22	18/22
D-134		6.35	7.14	.51x9.27	66.80/26.67	18	16.5
D-135		6.35	7.11	.46x9.27	26.67/26.67	19.1/19.5	19.1/19.5
D-136		6.35	7.62	.64x8.89	36.07	38.1/41	35/38
D-137		6.35	6.35	.46x8.89	Uneven Legs	16/31.5	16/31.5
D-138		6.35	6.35	.46x8.89	Uneven Legs	16/31.5	16/31.5
D-139		6.35	5.59	.46x9.27	39.12	14.3/22	13.3/22
D-230		6.63	7.11	.51x9.27	Small V	19.1/29	19.1/29
D-140	(0117-302)	7.67	9.40	.51x11.18	52.07	21/28	21/28
D-140-S	(0117-302-S)	7.67	9.40	.51x11.18	52.07	21/28	21/28
D-140-X	(0117-302)	7.67	9.40	.51x11.18	52.07	21/28	21/28
D-140-X-S	(0117-302-X-S)	7.67	9.40	.51x11.18	52.07	21/28	21/28

ALL VALCO^{fi} SNAP-BUTTONS are 1050 Spring Steel and .0051 Zinc Plated minimum, unless otherwise noted.

For items plated otherwise, Specify: -B for Black Zinc finish

-G for Zinc/Gold Dichromate finish

-N Nickel plated finish, e.g. D-130-N

-D = Dome Head, e.g. D-130-D

-S = Standard item with steel insert crimped in button head

-X = Standard item in 410 Stainless Steel



Made exclusively by VALCO^{fi} VALLEY TOOL & DIE, INC.

10020 York Theta Drive, North Royalton, Ohio 44133

(440) 237-0160 Fax (440) 237-0089 Website: <http://www.valcocleve.com>

VALCO^{fi} SNAP-BUTTON D-DOUBLE END

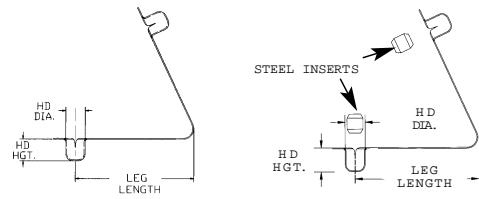

P/N	OLD P/N	HD. DIA.	HD. HGT.	MATERIAL SIZE	LEG LENGTH	TUBING I.D. S	
						ROUND	SQUARE
D-150	(0117-312)	7.92	9.40	.51x11.18	52.07	21/28	21/28
D-150-S	(0117-312)	7.92	9.40	.51x11.18	52.07	21/28	21/28
D-151	(0117-312)	7.92	7.87	.51x11.18	52.07	20/28	19.1/28
D-152		7.87	6.35	.51x11.18	52.07	22/25	22/25
D-153		7.87	9.40	.51x11.18	52.07	25.4/38	25.4/38
D-154-X		7.87	8.38	.64x12.95	44.70	21.6/33	
D-160	(0117-365)	9.27	11.18	.64x12.95	71.63	25.4/47.5	25.4/47.5
D-161		9.27	9.40	.64x12.95	50.80/50.80	25.4/34.5	25.4/34.5
D-162		9.27	11.18	.64x12.95	92.20	28.5/69.5	28.5/69.5
D-163-X		9.22	9.40	.51x11.18	51.31	24.9/34.5	
D-281		9.27	9.40	.64x12.95	Large Radius	44.5	44.5
D-170	(RD-251)	9.53	7.87	.64x12.95	44.45	20.4/25	19.1/25
D-171		9.53	6.86	.64x12.95	44.45	19.1/25	18/25
D-180	(0117-375-31)	9.53	7.87	.64x13.46	71.63	18.3/47.5	18/47.5
D-280		9.53	8.38	.51x12.70	53.85	25.4/38	22.1/38
D-181	(0117-375-37)	9.53	9.40	.64x13.46	71.63	22.1/47.5	22.1/47.5
D-182	(0117-375-44)	9.53	11.18	.64x13.46	71.63	25.4/47.5	25.4/47.5
D-182-X	(0117-375-44)	9.53	11.18	.64x13.46	71.63	25.4/47.5	25.4/47.5
D-182-S	(0117-375-44-S)	9.53	11.18	.64x13.46	71.63	25.4/47.5	25.4/47.5
D-282-X		9.53	14.22	.64x13.46	187.45 Flat	74/88.5	74/88.5
D-183	(0117-375-.50)	9.53	12.70	.64x13.46	70.36	28.5/44	28/44
D-183-S	(0117-375-.50)	9.53	12.70	.64x13.46	70.36	28.5/44	28/44
D-283		9.53	6.35	.64x13.46	73.66	22.1/34.5	22.1/34.5
D-184	(0127-375)	9.53	11.18	.64x13.46	125.22	25.4/63.5	25.4/63.5
D-284		9.53	11.30	.64x13.46	71.12	U-Channel	25.4W x 28.5H
D-185		9.53	12.70	.64x13.46	91.95	38.1/63.5	38.1/63.5
D-285		9.53	8.89	.46x13.46	43.94	22.1/28	22/28
D-186		9.53	12.70	.64x13.46	92.20	38.1/66.5	38.1/66.5
D-186-X		9.53	12.70	.64x13.46	92.20	38.1/66.5	38.1/66.5
D-286		9.53	9.42	.64x13.46	44.45	92/107.5	92/107.5
D-187		9.53	8.89	.46x13.46	43.43/43.43	23/38	23/38
D-188		9.53	9.40	.64x13.46	72.39/72.39	24.2/50.5	24.2/50.5
D-189		9.53	7.87	.64x13.46	92.20	38.1/66.5	38.1/66.5
D-190		10.92	14.22	.64x15.88	27.94	64/69.5	60.2/69.5
D-190-X	(0223-43)	10.92	14.22	.64x15.88	27.94	64/69.5	60.2/69.5
D-191		10.92	12.70	.64x15.88	35.56	76.2/88.5	76.2/88.5
D-200		12.70	13.21	.76x17.27	78.49	32/38	32/38

ALL VALCO^{fi} SNAP-BUTTONS are 1050 Spring Steel and .0051 Zinc Plated minimum, unless otherwise noted.
 For items plated otherwise, Specify: -B for Black Zinc finish -D = Dome Head, e.g. D-130-D
 -G for Zinc/Gold Dichromate finish -S = Standard item with steel insert crimped in button head
 -N Nickel plated finish, e.g. D-130-N -X = Standard item in 410 Stainless Steel



Made exclusively by VALCO^{fi} VALLEY TOOL & DIE, INC.

10020 York Theta Drive, North Royalton, Ohio 44133

(440) 237-0160 Fax (440) 237-0089 Website: <http://www.valcocleve.com>

VALCO^{fi} E STYLE SNAP-BUTTONS

are an excellent choice for your folding applications!

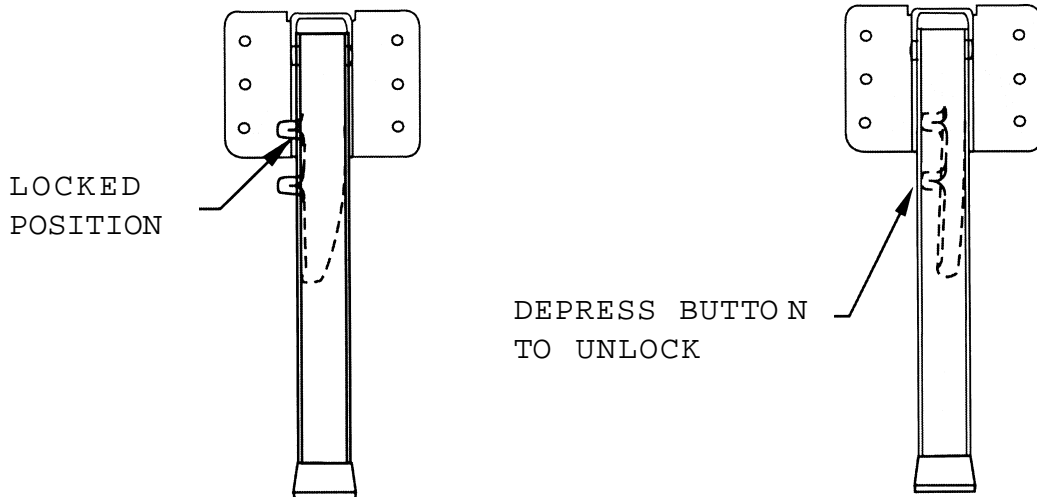
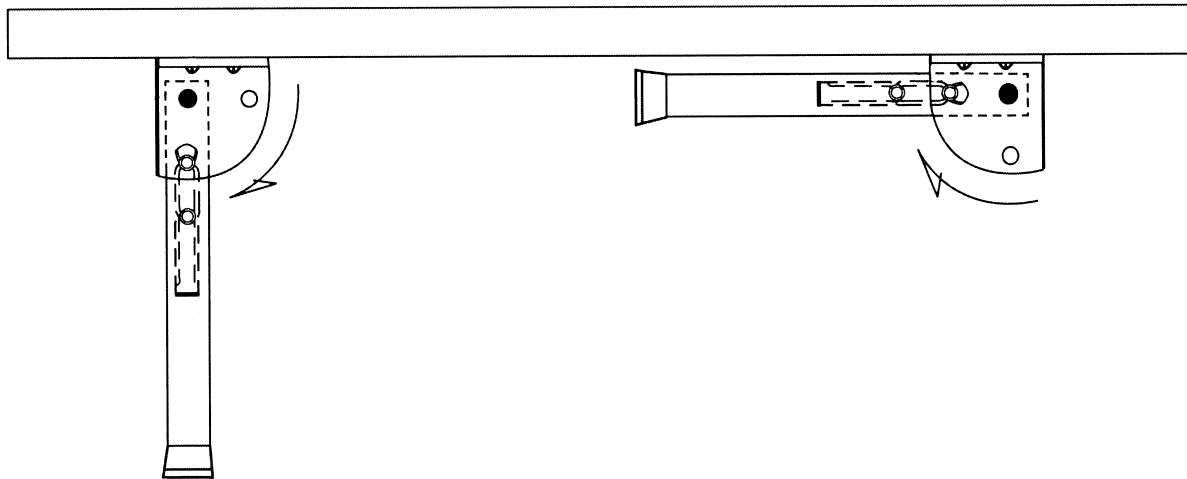

Made exclusively by VALCO^{fi} VALLEY TOOL & DIE, INC.

10020 York Theta Drive, North Royalton, Ohio 44133

(440) 237-0160 Fax (440) 237-0089 Website: <http://www.valcocleve.com>

VALCO^{fi} SNAP-BUTTON E-DUAL TYPE

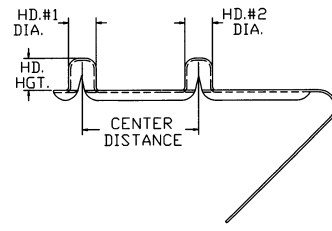

P/N	OLD P/N OR FEATURES	BUTTON HEAD DIAMETERS		BUTTON HEAD HEIGHTS		CENTER DISTANCE	TUBING I.D. S	
		#1	#2	#1	#2		ROUND	SQUARE
E-070	Dog Leg	3.91	3.91	6.35	6.35	19.05	11.5/15.5	11.5/15.5
E-100		4.75	4.75	6.35	6.35	25.40	13/22	13/22
E-110	(0118-219-28)	5.56	5.56	7.11	7.11	25.40	11.2/19	11.2/19
E-112	Short Dog Leg	5.56	5.56	6.86	6.86	25.40	13/19	13/19
E-130	(0118-250)	6.10	6.10	7.11	7.11	25.40	13/19	11.2/19
E-130-X	(0118-250)	6.10	6.10	7.11	7.11	25.40	13/19	11.2/19
E-131	(0190-250)	6.35	6.35	7.87	5.08	25.40	13/19	11.2/19
E-132		6.10	6.10	9.40	7.11	25.40	13/19	13/19
E-133		6.10	6.10	7.11	7.11	38.10	16/22	16/22
E-140	(0118-302K)	7.67	7.67	9.40	7.37	25.40	13.3/25	13.3/25
E-141	(0118-302)	7.67	7.67	9.40	9.40	25.40	16/25	16/25
E-141-X	(0118-302)	7.67	7.67	9.40	9.40	25.40	16/25	16/25
E-142	(0237-302)	7.67	7.67	9.91	8.13	25.40	17.3/31.5	15.3/31.5
E-143	(0118-302G)	7.67	7.67	9.40	6.35	25.40	13.3/25	13.3/25
E-144		7.62	7.62	9.40	9.40	15.88	13.3/25	11.5/25
E-145		7.62	7.62	9.40	9.40	38.10	22.1/31.5	22.1/31.5
E-146		7.67	7.67	7.87	7.87	25.40	13/25	13/25
E-146-X		7.67	7.67	7.87	7.87	25.40	13/25	13/25
E-147		4.75	7.62	5.59	7.37	19.05	18/25	16/25
E-148		7.62	7.62	7.11	7.11	25.40	20.4/35.5	20.4/35.5
E-149		4.75	7.62	6.35	7.37	19.05	16/22.5	16/22.5
E-150		7.67	7.67	9.40	7.37	38.10	16/22.5	16/22.5
E-160	(0118-365)	9.27	9.27	9.40	9.40	25.40	17.1/34.5	17.1/34.5
E-161	(0136-365)	9.27	9.27	7.87	9.91	25.40	17.1/34.5	17.1/34.5
E-162		9.27	9.27	9.40	9.40	25.40	25.4/34	19.1/34
E-163	Dog Leg	9.27	9.27	10.92	10.92	25.40	25.4/33	24/33
E-181	(0134-375-25)	6.35	9.27	7.62	9.40	19.05	17.1/34.5	17.1/34.5

VALCO^{fi} SNAP-BUTTON ED-DOUBLE DUAL TYPE

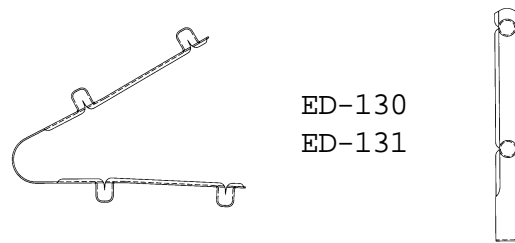

P/N	OLD P/N OR FEATURES	BUTTON HEAD DIAMETERS		BUTTON HEAD HEIGHTS		CENTER DISTANCE	TUBING I.D. S	
		#1	#2	#1	#2		ROUND	SQUARE
ED-100		4.98	4.98	5.59	5.59	25.40	17.5	17.5
ED-130	4 Button	6.35	6.35	7.11	7.11	44.45	28	28
ED-131	Heads	6.35	6.35	6.35	5.59	44.45	15.5	19
ED-132		6.35	6.35	6.35	5.59	73.15	19	19
ED-140		7.67	7.67	8.13	8.13	25.40	25	25

ALL VALCO^{fi} SNAP-BUTTONS are 1050 Spring Steel and .0051 Zinc Plated minimum, unless otherwise noted.

For items plated otherwise:

- B = for Black Zinc finish
- N = Nickel plated finish, e.g. E-130-N
- G = Zinc/Gold Dichromate finish
- D = Dome Head
- S = Standard item with steel insert crimped in button head
- X = Standard item in 410 Stainless Steel



Made exclusively by VALCO^{fi} VALLEY TOOL & DIE, INC.

10020 York Theta Drive, North Royalton, Ohio 44133

(440) 237-0160 Fax (440) 237-0089 Website: <http://www.valcocleve.com>

VALCO^{fi} SNAP-BUTTON E-DUAL TYPE

P/N	OLD P/N OR FEATURES	BUTTON HEAD DIAMETERS		BUTTON HEAD HEIGHTS		CENTER DISTANCE	TUBING I.D. S	
		#1	#2	#1	#2		ROUND	SQUARE
EC-144	EE-144	7.62	7.62	9.40	9.40	15.88	20.4/28	17.1/28
EC-145		7.62	7.62	10.16	10.16	15.88	24/27.5	21.4/27.5

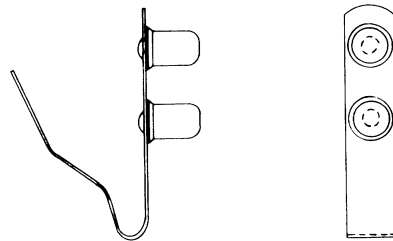

EC-145

P/N	OLD P/N OR FEATURES	BUTTON HEAD DIAMETERS		BUTTON HEAD HEIGHTS		CENTER DISTANCE	TUBING I.D. S	
		#1	#2	#1	#2		ROUND	SQUARE
ER-180		9.53	9.53	11.18	7.87	17.65	25.4/44	25.4/44

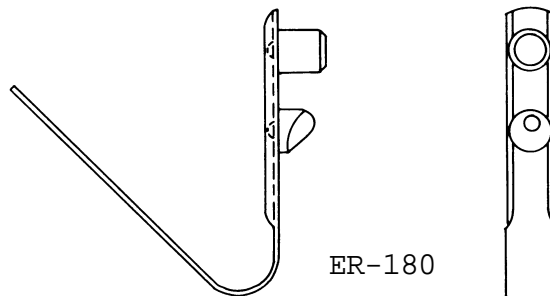

ER-180

ALL VALCO^{fi} SNAP-BUTTONS are 1050 Spring Steel and .0051 Zinc Plated minimum, unless otherwise noted.

For items plated otherwise:

- B = for Black Zinc finish
- G = Zinc/Gold Dichromate finish
- N = Nickel plated finish, e.g. E-130-N
- D = Dome Head
- S = Standard item with steel insert crimped in button head
- X = Standard item in 410 Stainless Steel



Made exclusively by VALCO^{fi} VALLEY TOOL & DIE, INC.

10020 York Theta Drive, North Royalton, Ohio 44133

(440) 237-0160 Fax (440) 237-0089 Website: <http://www.valcocleve.com>

F STYLE VALCO^{fi} SNAP-BUTTONS rivet into place where an obstruction-free application is needed. F STYLE SNAP-BUTTONS fit round or rectangle tubing as well as various sliding extrusions.

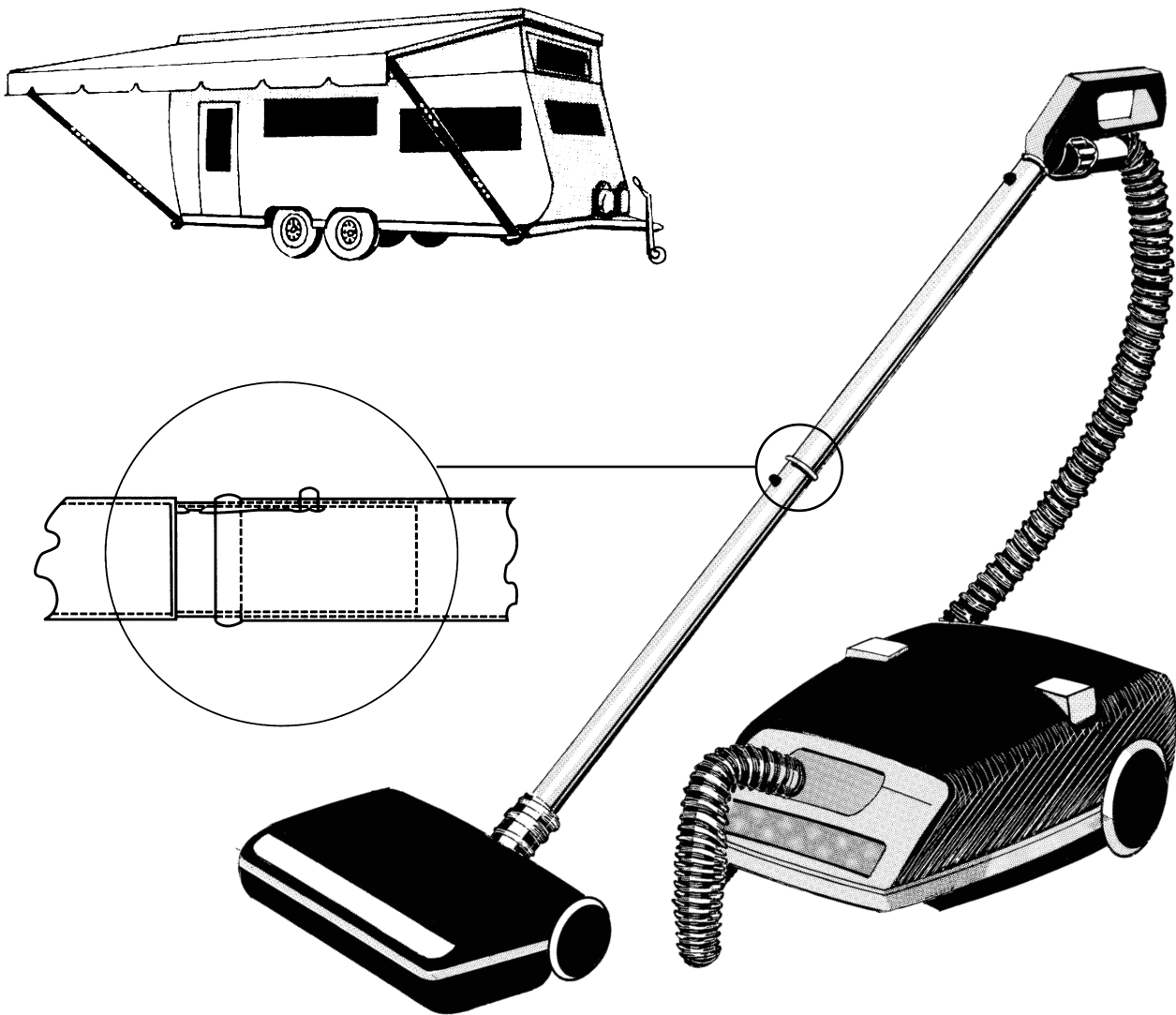

Made exclusively by VALCO^{fi} VALLEY TOOL & DIE, INC.

10020 York Theta Drive, North Royalton, Ohio 44133

(440) 237-0160 Fax (440) 237-0089 Website: <http://www.valcocleve.com>

VALCO^{fi} SNAP-BUTTON

F-DUAL TYPE

P/N	SPECIAL FEATURES	BUTTON HEAD DIAMETERS		BUTTON HEAD HEIGHTS		HOLE DIA.	CENTER DISTANCE	OVERALL LENGTH
		#1	#2	#1	#2			
FE-135		6.35	6.35	10.92	10.92	5.08	41.28	88.90
FE-135-S		6.35	6.35	10.92	10.92	5.08	41.28	88.90
FE-145	90° End Tab	7.62	7.62	9.65	9.65	-	38.10	113.79

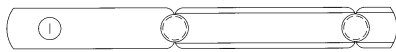

FE-135, FE-135-S



FE-145



P/N	SPECIAL FEATURES	BUTTON HEAD DIAMETERS		BUTTON HEAD HEIGHTS		HOLE DIA.	CENTER DISTANCE	OVERALL LENGTH
		#1	#2	#1	#2			
FEC-160	1 Solid Head	6.35	9.27	7.62	9.53	3.25	27.94	57.40
FEC-180	2 Solid Heads	6.35	9.40	7.14	7.87	3.25	28.58	77.72
FLX-180	Rectang. ramp	6.35	9.53	10.16	14.99	3.30	47.63	122.43



FEC-160

FD-140

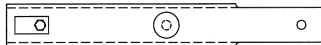
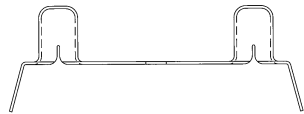

FLX-180



P/N	OLD P/N OR FEATURES	BUTTON HEAD DIAMETERS		BUTTON HEAD HEIGHTS		HOLE DIA.	CENTER DISTANCE	OVERALL LENGTH
		#1	#2	#1	#2			
FD-140		7.62	7.62	10.92	10.92	4.01	38.10	57.15
FDC-181		9.53	9.53	12.70	12.70		128.27	147.32

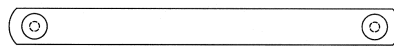

ALL VALCO^{fi} SNAP-BUTTONS are 1050 Spring Steel and .0051 Zinc Plated minimum, unless otherwise noted.

For items plated otherwise:

Specify: -B for Black Zinc finish

-N Nickel plated finish, e.g. FE-135-N

-G for Zinc/Gold Dichromate finish

-D = Dome Head

-S = Standard item with steel insert crimped in button head

-X = Standard item in 410 Stainless Steel



Made exclusively by VALCO^{fi} VALLEY TOOL & DIE, INC.

10020 York Theta Drive, North Royalton, Ohio 44133

(440) 237-0160 Fax (440) 237-0089 Website: <http://www.valcocleve.com>

VALCO^{fi} SNAP-BUTTON

F-FLAT TYPE

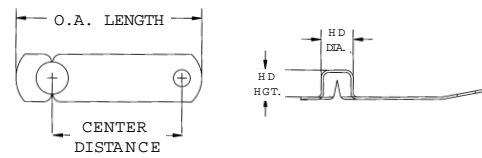

P/N	OLD P/N	HD. DIA.	HD. HGT.	MATERIAL SIZE	HOLE DIA.	CENTER DISTANCE	OVERALL LENGTH	ILLUSTRATION NUMBER
F-100-D		4.57	7.11	.46x6.60	3.28	38.10	49.78	1
F-100-X	(0142-180)	4.57	7.11	.46x6.60	3.28	38.10	49.78	1
F-100-X-S	(0142-180)	4.57	7.11	.46x6.60	3.28	38.10	49.78	1
FM-100	4.76 Mushroom HD	4.70	4.83	.51x6.48	3.33	25.27	39.62	31
F-101		4.57	7.11	.46x6.60	3.28	38.10	49.78	1
F-102		4.57	7.11	.46x6.60	N/A	N/A	49.53	2
F-103		4.70	4.06	.46x9.27		25.27	39.62	2
F-110-.012		5.56	4.57	.31x9.27	3.25	21.59	33.78	2
F-110-.018	(0138-219)	5.56	4.57	.46x8.26	3.25	21.59	33.78	2
F-111	(0212-219-A)	5.56	8.13	.51x12.70	6.73	39.62 in Flat		3
F-112	(0212-219-B)	5.56	9.40	.51x12.70	6.73	63.50 In Flat		4
F-113		5.56	9.40	.51x12.70	3.58	63.50 In Flat		4
F-114		5.49	8.13	.51x12.70	6.73	39.67	61.98	5
F-115		5.51	7.11	.51x8.25	3.30	50.80	127.00	6
F-116		5.49	8.13	.51x12.70	6.73	39.67	57.15	4
F-120	(0141-250-1CD)	6.35	5.33	.46x9.27	3.58	25.40	36.32	8
F-121	(0141-250-25)	6.35	6.35	.46x9.27	3.58	24.64	36.32	8
F-122	(0141-250-31)	6.35	7.87	.46x9.27	3.58	24.64	35.31	8
F-123	(0142-250-B)	6.35	4.57	.46x9.27	3.25	38.10	50.80	8
F-124	(0142-250-M)	6.35	7.11	.46x9.27	3.25	38.10	50.80	8
F-125		6.35	8.89	.46x9.27	2.64	21.34	31.75	8
F-126		6.35	8.89	.46x9.27	3.58	21.34	31.75	8
F-127		6.35	6.35	.46x9.27	5.56	24.64	36.32	8
F-128		6.35	7.11	.46x9.27	3.25	27.94	38.86	8
F-129		6.35	4.57	.46x9.27	3.25	25.40/38.10	50.80	31
F-130	(0124-250)	6.35	5.33	.46x9.27	3.25	21.44 in flat	31.75	9
F-230		6.35	7.11	.51x12.70	5.18	50.80	88.90	10
F-131	(0129-250)	6.35	5.33	.46x9.27	3.25	29.97	50.80	13
F-231		6.35	5.08	.46x9.27	3.30	34.80	50.80	13
F-132	(0210-250)	6.35	7.87	.46x6.35	N/A	N/A	63.50	11
F-232		6.35	7.11	.46x9.27	3.25	38.10	57.15	19
F-133	(0216-250)	6.35	7.11	.46x9.27	3.25	38.10	57.15	10
F-134	(0222-250)	6.35	7.11	.46x9.27	N/A	N/A	74.17	11
F-234		6.35	5.33	.46x9.27	3.38	21.44 in flat	31.75	9
F-135		7.14	9.40	.76x14.22	6.35x12.70	57.15	76.20	12
F-235		6.35	5.33	.41x9.53	3.38	34.80	50.80	26
F-136	(0235-250-30)	6.35	7.62	.46x9.27	3.25	34.80	50.80	13
F-236		6.35	7.62	.46x9.27	2.44	34.93	50.80	13
F-137	(0235-250-20)	6.35	5.08	.46x9.27	2.41	34.80	50.80	13
F-138		6.35	8.64	.46x9.27	N/A		79.50	11
F-138-X		6.35	8.64	.46x9.27	N/A		79.50	11
F-139		6.35	8.64	.46x9.27	3.25(2)	25.40/46.02	79.25	14
F-140	(0206-302)	7.67	9.65	.51x11.18	N/A		90.30	11
F-140-S	(0206-302)	7.67	9.65	.51x11.18	N/A		90.30	11
F-141	(0166-302)	7.67	9.40	.51x11.18	4.83	44.45	76.20	15
F-241		7.67	12.70	.64x11.18	4.85	45.34	77.22	15
F-142	(0229-302)	7.67	7.62	.51x11.18	5.16	38.10	60.45	8
F-143	(0159-302)	7.62(2)	9.40(2)	.51x11.18	3.58(2)			16
F-144	F-141 w/o Lift Tab	7.67	9.40	.51x11.18	4.83	44.45	58.67	17
F-145		7.67	10.92	.51x11.18	5.16	38.10	60.45	8
F-146		7.67	12.70	.51x11.18	5.16	45.21	63.75	18
F-148		7.67	9.40	.51x11.18	3.66	47.63	63.50	11
F-246		7.62	12.70	.51x11.18	5.16	45.24	63.50	23

ALL VALCO^{fi} SNAP-BUTTONS are 1050 Spring Steel and .0051 Zinc Plated minimum, unless otherwise noted.

For items plated otherwise:

Specify: -B for Black Zinc finish

-N Nickel plated finish, e.g. F-130-N

-G for Zinc/Gold Dichromate finish

-D = Dome Head

-S = Standard item with steel insert crimped in button head

-X = Standard item in 410 Stainless Steel



Made exclusively by VALCO^{fi} VALLEY TOOL & DIE, INC.

10020 York Theta Drive, North Royalton, Ohio 44133

(440) 237-0160 Fax (440) 237-0089 Website: <http://www.valcocleveland.com>

VALCO^{fi} SNAP-BUTTON

F-FLAT TYPE

P/N	OLD P/N	HD. DIA.	HD. HGT.	MATERIAL SIZE	HOLE DIA.	CENTER DISTANCE	OVERALL LENGTH	ILLUSTRATION NUMBER
F-147		7.62	12.70	.51x11.18	5.16	45.24	63.50	23
F-247		7.62	12.70	.64x11.18	5.16	45.24	63.50	23
F-150	(0141-312)	7.92	6.35	.51x11.18	3.58	24.64	36.32	8
F-151		7.92	9.40	.51x11.18	4.37(2x)	A-35.81/B-45.21	63.50	14
F-152	(0142-312)	7.92	6.35	.51x11.18	3.30	15.88	26.92	18
F-153		7.92	12.70	.51x11.184	.37(2x)	A-35.81/B-45.21	63.50	14
F-154		7.92	9.65	.51x11.18	4.37	31.75	44.45	8
F-155		7.92	15.75	.51x11.18	4.75	50.80/69.85	88.90	20
F-155-S		7.92	15.75	.51x11.18	4.75	50.80/69.85	88.90	20
F-156		8.00	5.21	.51x11.18		Clip	65.02	29
F-157		7.92	9.53	.51x11.18	4.85	38.10	50.80	1
F-158		7.87	5.08	.46x11.18		Clip	64.77	29
F-159		7.87	15.88	.51x11.18	4.85	50.80	71.37	
F-250		8.74	6.60	.46x12.70	3.25	28.58	47.75	19
F-160	(0141-365-25)	9.27	6.35	.64x12.95	3.25	32.51	54.61	8
F-161	(0141-365-50)	9.27	12.70	.64x12.95	3.25	50.80	72.90	8
F-162	(0231-365)	9.27	12.70	.64x12.95	3.25	50.80	76.20	10
F-163	(0146-365)	9.27	7.11	.64x12.95	3.30	50.80	79.76	18
F-164		9.27	12.70	.64x12.95	3.25	50.80	76.20	21
F-165		9.27	15.88	.64x12.95	3.96	50.80	63.50	8
F-166		9.27	11.18	.64x12.95	6.63	38.10 in flat	53.85	30
F-167		9.27	11.18	.64x12.95	8.13	31.75	50.80	18
F-168		9.27	11.18	.64x12.95	3.66	38.10 flat	53.85	30
F-169		9.27	12.95	.64x12.95	3.25	50.80	72.90	19
F-180	(0175-375)	9.53	7.62	.64x12.95	4.75	50.80	70.61	22
F-181	(0205-375)	9.53	9.40	.64x12.95	3.30(2x)	A-71.37/B-93.73	111.00	14
F-182		9.53	9.40	.64x12.95	7.14	63.50	83.06	22
F-183		9.53	9.40	.64x12.95	4.83(2x)	33.35	72.90	14
F-184		9.53	11.18	.64x13.46			38.61	27
F-185		9.53	9.53	.64x12.95	3.25	55.63	73.15	32
F-222		6.27	8.38	.46x9.27	3.58	24.59	41.15	10
F-228		6.30	7.11	.51x9.27	3.25	27.94	38.86	2
F-233		6.27	9.53	.51x9.27	3.25	38.10		10
F-237		6.35	5.33	.46x8.89	3.25	25.40	51.31	21
F-238		6.27	9.53	.46x9.27	3.25(2x)	38.10/50.80(F)	77.72(Flat)	33
F-239		6.27	7.62	.46x9.27	3.25	38.10(Flat)	50.80	20
F-251		7.92	9.53	.51x11.18	4.37(2x)	1.406/1.781	63.50	34
F-330		6.30	.207	.31x9.27	3.25	21.34	31.75	9

FLAT TYPE SOLID BUTTON

P/N	OLD P/N	HD. DIA.	HD. HGT.	MATERIAL SIZE	HOLE DIA.	CENTER DISTANCE	OVERALL LENGTH	ILLUSTRATION NUMBER
FC-117		5.56	8.13	.76x12.70	6.73	39.62	60.45	7
FC-118		5.54	8.13	.76x12.70	6.73	39.67	60.45	35
FC-120		6.10	7.87	.64x9.53	4.78	38.10 in flat	47.50	28
FC-132		6.35	9.40	.51x11.18	4.83	41.28	73.15	24
FC-133		6.35	14.22	.51x11.18	4.83	41.28	73.15	24
FC-134		6.30	7.11	.51x6.35			69.85	36
FC-135		6.35	9.53	.64x12.95	4.75	50.80	70.61	37
FC-151		7.92	12.70	.51x11.18	4.83	44.45	80.01	25
FC-152		7.92	15.75	.51x11.18	4.85	44.45	77.22	25
FC-153		7.87	7.92	.51x11.18	4.85	44.45	77.22	
FC-154		7.87	9.53	.51x11.18	4.85	44.45	77.22	
FC-155		11.18	7.87	.64x11.18	4.85	31.75	52.83	
FC-156		7.95	8.74	.64x16.66	3.25	31.75	50.80	38
FC-180		9.53	11.18	.76x12.70	4.78(2x)	33.35/50.80	73.28	
FC-181		9.53	12.70	.64x13.46			147.32	



Made exclusively by VALCO^{fi} VALLEY TOOL & DIE, INC.

10020 York Theta Drive, North Royalton, Ohio 44133

(440) 237-0160 Fax (440) 237-0089 Website: <http://www.valcocleveland.com>

VALCO^{fi} SNAP-BUTTON

F-FLAT TYPE

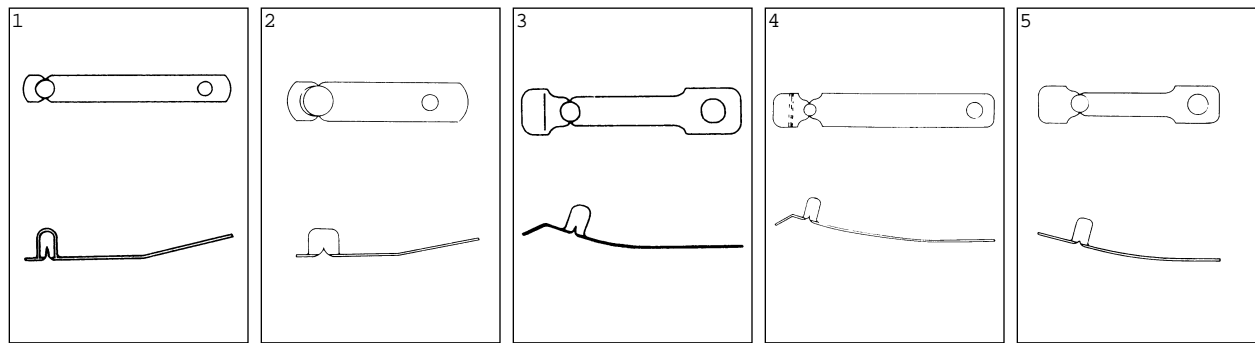

F-100, F-101
F-157

F-110, F-128

F-111

F-112, F-113
F-116

F-114

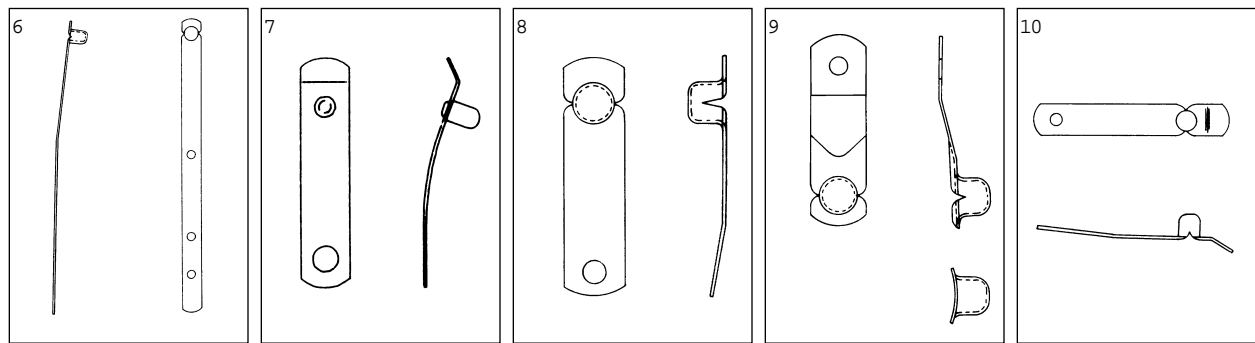

F-115

FC-117, FC-133

F-120, F-121, F-122
F-123, F-124, F-125
F-126, F-127, F-128
F-142, F-145, F-150
F-154, F-160, F-161

F-130

F-133, F-162
F-222, F-230
F-233

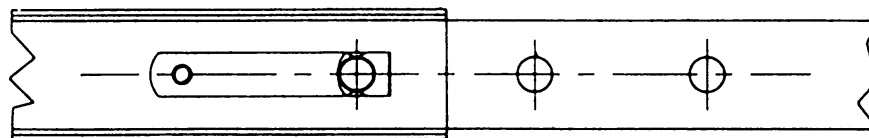
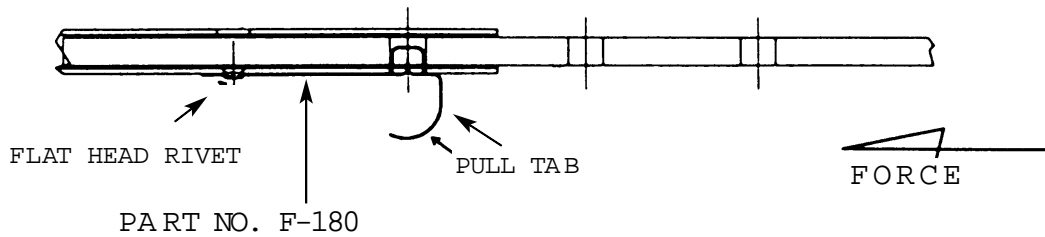

Please Note: Above drawings illustrate contours only. They are not to scale.



Made exclusively by VALCO^{fi} VALLEY TOOL & DIE, INC.

10020 York Theta Drive, North Royalton, Ohio 44133

(440) 237-0160 Fax (440) 237-0089 Website: <http://www.valcocleve.com>

VALCO^{fi} SNAP-BUTTON

F-FLAT TYPE

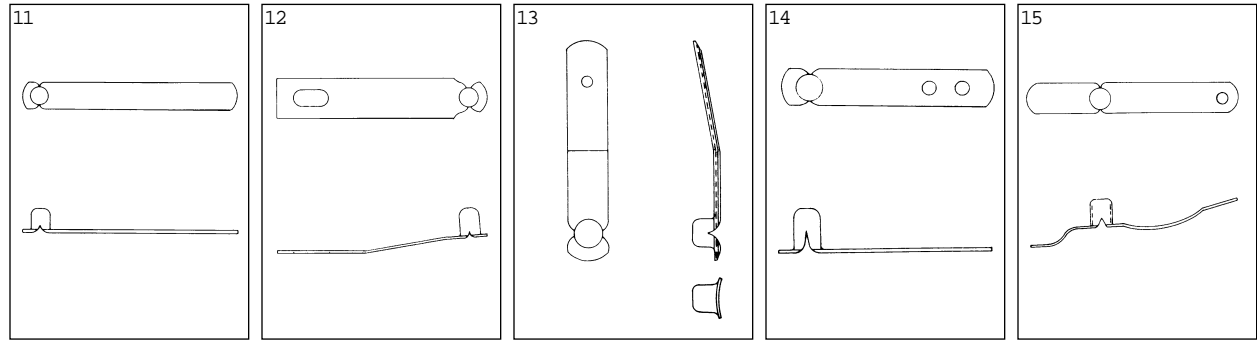

F-132, F-134
F-138, F-140

F-135

F-131, F-136, F-137
F-231, F-236

F-139, F-151,
F-153, F-181
F-183

F-141

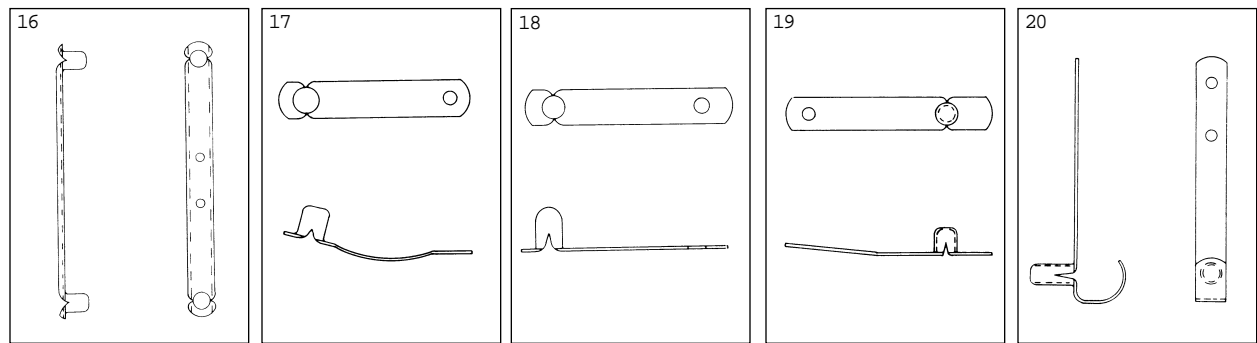

F-143

F-144

F-146, F-152, F-163

F-232, F-250, F-169

F-155, F-239

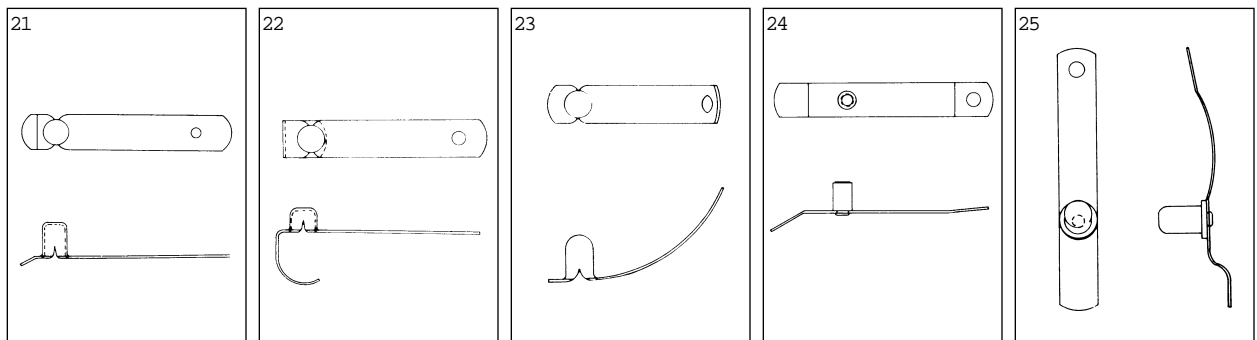

F-164, F-237

F-180, F-182

F-147, F-246

FC-132

FC-151

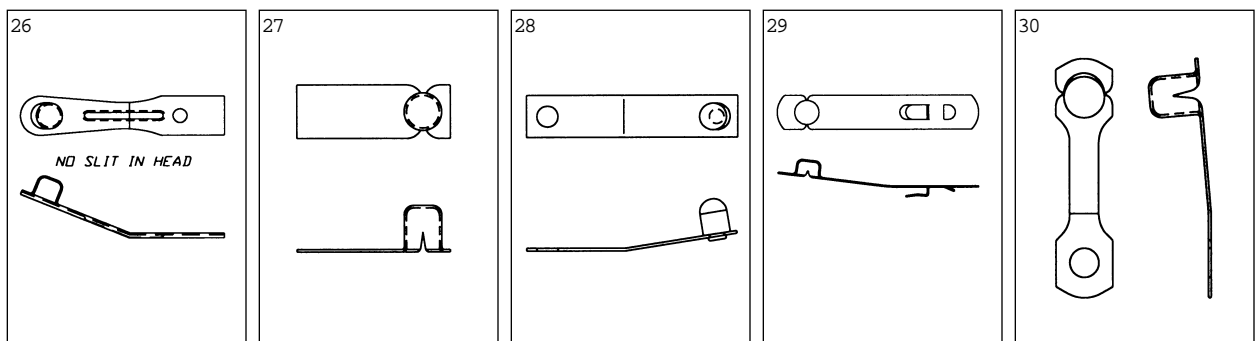

F-235

F-184

FC-120
FC-250

F-156, F-158

F-166, F-168

Please Note: Above drawings illustrate contours only. They are not to scale.



Made exclusively by VALCO^{fi} VALLEY TOOL & DIE, INC.

10020 York Theta Drive, North Royalton, Ohio 44133

(440) 237-0160 Fax (440) 237-0089 Website: <http://www.valcocleve.com>

VALCO^{fi} SNAP-BUTTON

F-FLAT TYPE

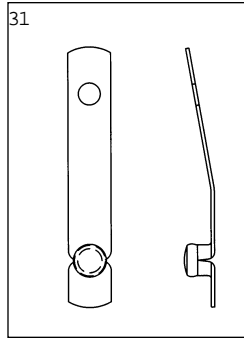

FM-100

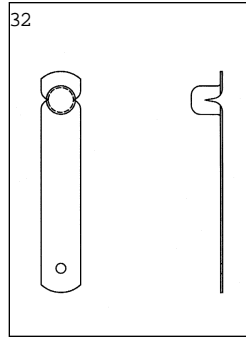

F-185

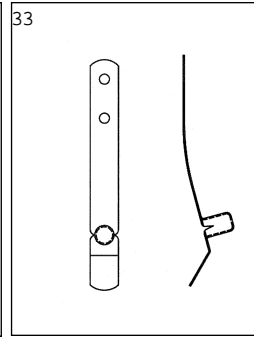

F-238

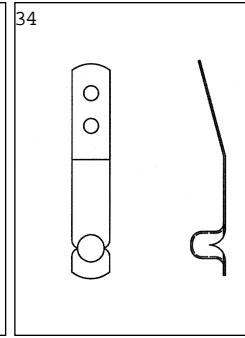

F-251

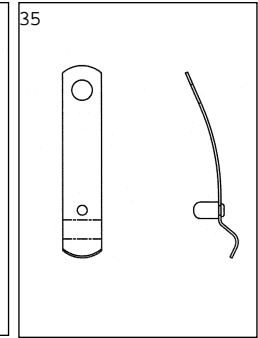

FC-118

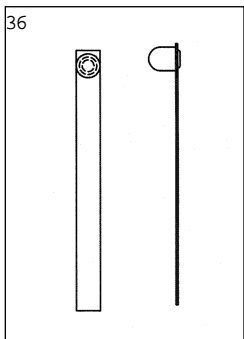

FC-134

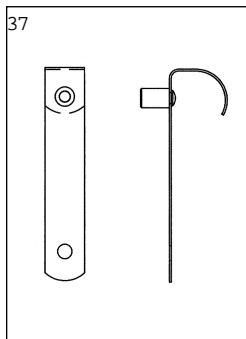

FC-135

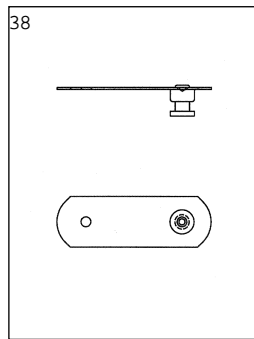

FC-156

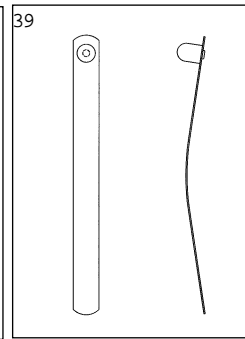

FC-181

Please Note: Above drawings illustrate contours only. They are not to scale.



Made exclusively by VALCO^{fi} VALLEY TOOL & DIE, INC.

10020 York Theta Drive, North Royalton, Ohio 44133

(440) 237-0160 Fax (440) 237-0089 Website: <http://www.valcocleve.com>

VALCO^{fi} SNAP-BUTTON G - TYPE

P/N	OLD P/N	HD. DIA.	HD. HGT.
G-120	0137-250	6.35	12.70
G-121		6.35	12.70
G-122		5.99	7.11
G-130		6.35	6.86
G-131		6.35	6.35
G-132		6.35	7.87
G-134		6.35	9.65
G-135		6.35	5.08
G-136		6.35	6.86
G-152		7.92	9.65
G-153		7.87	7.62
G-154		7.92	9.65
G-155		7.92	9.65
G-231		6.35	7.87
G-300		15.75	11.18

P/N	OLD P/N	HD. DIA.	HD. HGT.
GC-137		6.35	9.40
GC-140		7.62	12.70
GC-141		7.92	11.68
GC-142		7.62	11.18
GC-150		7.87	14.22
GC-152		8.33	7.11

P/N	OLD P/N	BUTTON HEAD DIAMETERS		BUTTON HEAD HEIGHTS	
		#1	#2	#1	#2
		GR-151-L		7.92	
GR-151-R		7.92		7.75	
GR-180		9.53		4.85	
GR-181		6.35	9.53	3.18	7.87

ALL VALCO^{fi} SNAP-BUTTONS are 1050 Spring Steel and .0051 Zinc Plated minimum, unless otherwise noted.

For items plated otherwise:

Specify: -B for Black Zinc finish

-G for Zinc/Gold Dichromate finish

-N Nickel plated finish, e.g. G-150-N

-D = Dome Head

-S = Standard item with steel insert crimped in button head

-X = Standard item in 410 Stainless Steel



Made exclusively by VALCO^{fi} VALLEY TOOL & DIE, INC.

10020 York Theta Drive, North Royalton, Ohio 44133

(440) 237-0160 Fax (440) 237-0089 Website: <http://www.valcocleve.com>

VALCO^{fi} SNAP-BUTTON G - TYPE

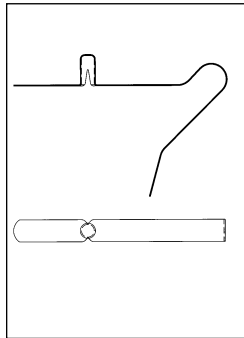

G-120

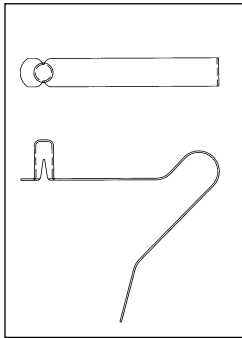

G-121

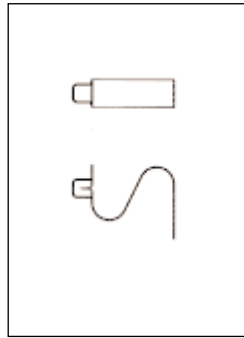

G-131

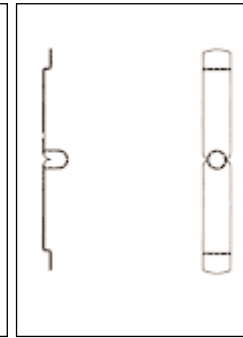

G-132

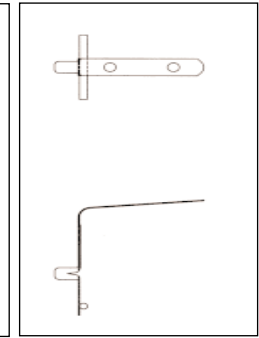

G-134

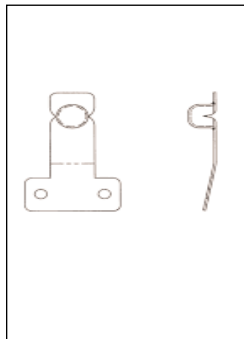

G-135

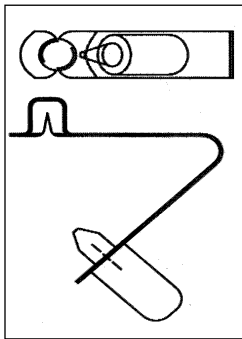

G-136

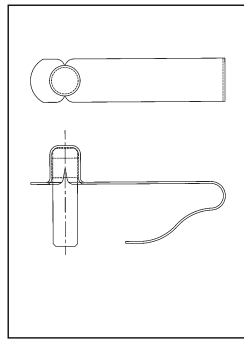

G-150

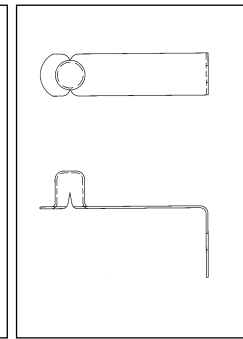

G-151

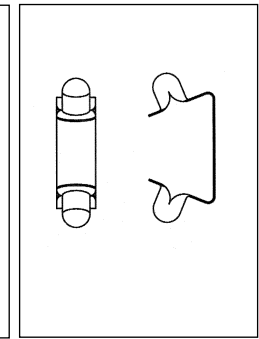

G-152

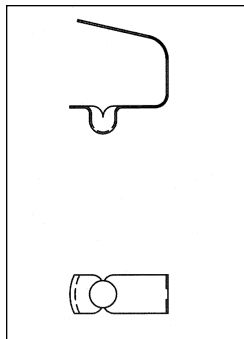

G-153

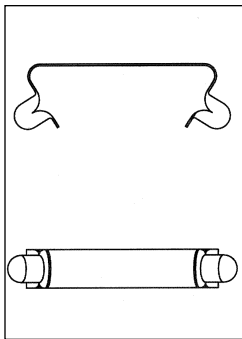

G-154

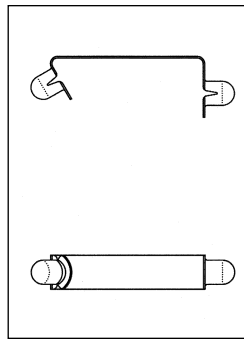

G-155

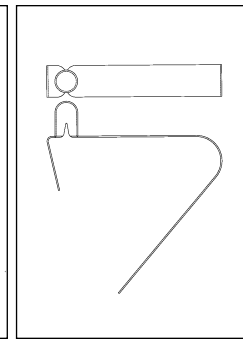

G-160

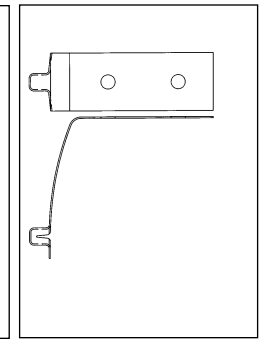

G-230

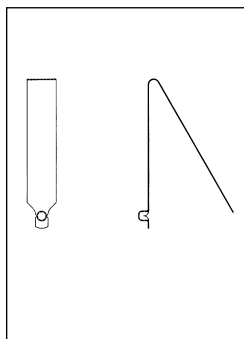

G-231

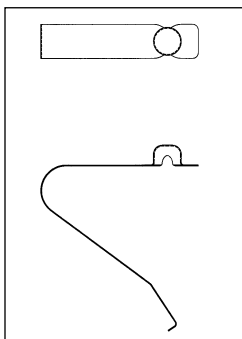

G-300-B



Made exclusively by VALCO^{fi} VALLEY TOOL & DIE, INC.

10020 York Theta Drive, North Royalton, Ohio 44133

(440) 237-0160 Fax (440) 237-0089 Website: <http://www.valcocleve.com>

VALCO^{fi} SNAP-BUTTON G - TYPE

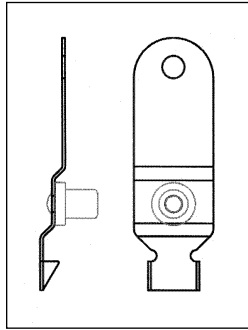

GC-137

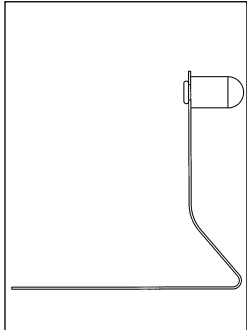

GC-140

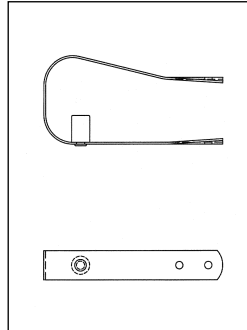

GC-141

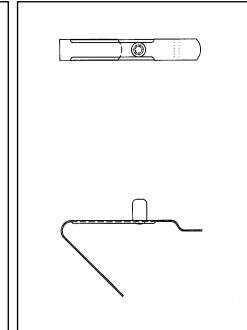

GC-142

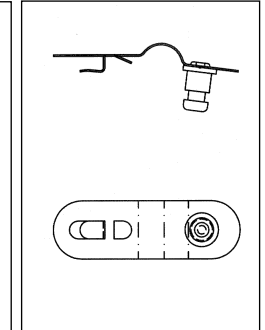

GC-150

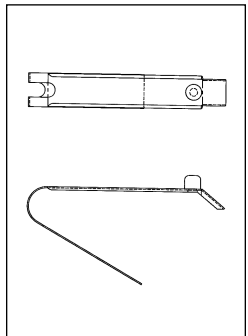

GC-152

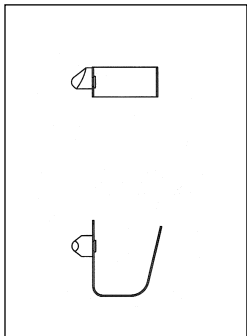

GR-151-L

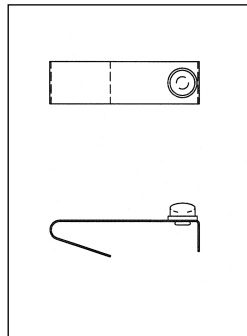

GR-180-L

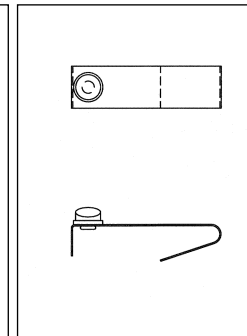

GR-180-R

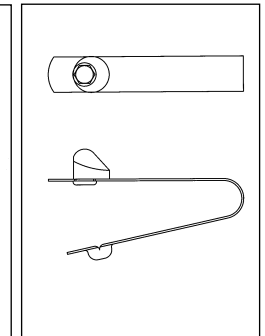

GR-181



Made exclusively by VALCO^{fi} VALLEY TOOL & DIE, INC.

10020 York Theta Drive, North Royalton, Ohio 44133

(440) 237-0160 Fax (440) 237-0089 Website: <http://www.valcocleve.com>

VALCO^{fi} SNAP-BUTTON

H - LEAF TYPE

DRAWN BUTTON

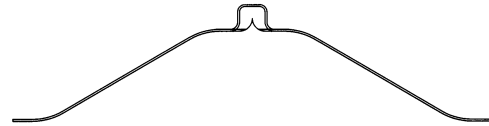

P/N	OLD P/N	HD.	HD.	MATERIAL SIZE	OVERALL LENGTH	TUBING I.D. S		
		DIA.	HGT.			ROUND	SQUARE	RECTANGLE
H-140		7.62	5.59	.51x11.18	50.80	13/13.5	-	11.5x10.2
H-160	(0120-365-TA)	9.27	7.87	.64x13.46	152.40	14/31.5	14/31.5	12.7x14-25
H-160-S	(0120-365-TSA)	9.27	7.87	.64x13.46	152.40	14/31.5	14/31.5	12x14-25
H-161	RD-897	9.27	7.87	.51x12.95	107.95	10/19	10/19	9.7x13.5-19
H-170	(0236-365)	9.27	7.87	.51x12.95	177.80	14/17.5	14/17.5	14x14-17.5
H-170-S	(0236-365-S)	9.27	7.87	.51x12.95	177.80	14/17.5	14/17.5	14x14-17.5
H-180	(0120-375-A)	9.53	11.18	.64x13.46	142.75	19.1/31.5	19.1/31.5	14x19.1-31.5
H-181	(0120-375-B)	9.53	11.18	.64x13.46	117.35	18/25	18/25	14x18-25
H-182		9.53	11.18	.51x12.95	66.55	12.7/15.3	12.7/15.3	14x12.7-15.75

VALCO^{fi} SNAP-BUTTONS

HC - TYPE

SOLID STEEL BUTTON ASSEMBLED TO SPRING

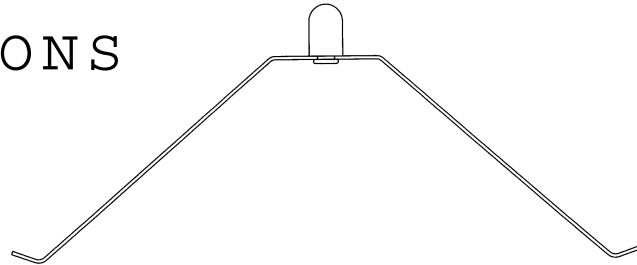

P/N	HD.	HD.	MATERIAL SIZE	OVERALL LENGTH	TUBING I.D. S		
	DIA.	HGT.			ROUND	SQUARE	RECTANGLE
HC-130	6.35	7.11	.64x8.89	146.05	19.1/38	19.1/38	9.4/38
HC-131	6.35	9.65	.64x8.89	146.05	19.1/38	19.1/38	9.4/38
HC-132	6.35	9.65	.51x8.89	146.05	19.1/38	19.1/38	9.4/38
HC-133	6.35	7.11	.38x8.89	146.05	13/31.5	13/31.5	9.7x13-31.5
HC-140	7.62	12.70	.51x8.76	114.30	25.4/38	19.1/38	9.4/38
HC-141	7.62	12.70	.51x8.25	114.30	19.1/31.5	19.1/31.5	9.4/31.5
HC-150	7.92	9.40	.51x8.89	146.05	19.1/38	19.1/38	9.4/38
HC-151	7.92	9.40	.64x8.89	146.05	19.1/38	19.1/38	9.4/38
HC-152	7.92	9.40	.38x8.89	146.05	19.1/38	19.1/38	9.4/38
HC-180	9.53	9.40	.38x10.67	75.18	15.3/15.5	15.3/41	13/41
HC-181	9.53	6.35	.31x10.67	75.18	13/15.5	13/41	13/41
HC-182	9.53	9.40	.64x8.89	146.05	19.1/38	19.1/38	9.4/38
HC-183	9.53	19.05	.64x8.89	146.05	28.5/38	28.5/38	9.4/38

ALL VALCO^{fi} SNAP-BUTTONS are 1050 Spring Steel and .0051 Zinc Plated minimum, unless otherwise noted.

For items plated otherwise:

Specify: -B for Black Zinc finish
 -G for Zinc/Gold Dichromate finish
 -N Nickel plated finish, e.g. H-130-N

-D = Dome Head
 -S = Standard item with steel insert crimped in button head
 -X = Standard item in 410 Stainless Steel



Made exclusively by VALCO^{fi} VALLEY TOOL & DIE, INC.

10020 York Theta Drive, North Royalton, Ohio 44133

(440) 237-0160 Fax (440) 237-0089 Website: <http://www.valcocleve.com>

VALCO^{fi} SNAP-BUTTON ASSEMBLIES

300 SERIES STAINLESS STEEL

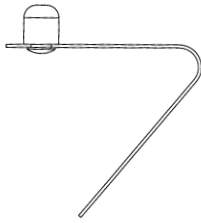

II-130

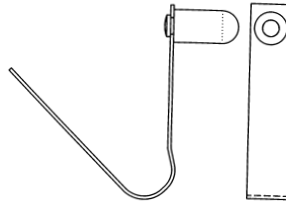

II-134

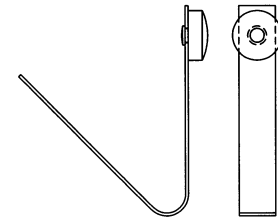

II-200

P/N	OLD P/N	H D DIA.	HD. HGT.	M ATERIAL SIZE	TUBING I.D. S	
					ROUND	SQUARE
II-050		3.18	4.06	.30x4.32	6.4/15	6.4/15
II-071		3.96	7.37	.46x5.33	14.5/16	14.5/16
II-130	(0202-250-28)	6.35	7.11	.55x6.35	11/22	10.5/22
II-132		6.35	9.40	.64x7.92	14/22	11/22
II-133	(0202-250-N)	6.35	9.40	.64x7.92	15/25	14/25
II-134		6.35	12.70	.64x7.92	19.1/25	19.1/25
II-135		6.35	15.75	.64x7.92	22.3/38	20.4/38
II-136		6.35	9.65	.46x9.27	19.1/36.5	19.1/36.5
II-150	(0202--312-37)	7.92	9.40	.64x7.92	14/25	13/25
II-174		9.53	14.99	.51x11.18	25.4/44	25.4/44
II-180	(0202-375-37)	9.53	9.40	.76x9.53	15.3/28	14/28
II-181		9.53	5.33	.76x9.53	19.1/38	19.1/38
II-200		12.70	5.08	.76x9.53	19.1/38	19.1/38
II-175		9.27	9.53	.51x11.18	20.4/35.5	20.4/35.5

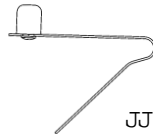

JJ 130

P/N	OLD P/N	H D DIA.	HD. HGT.	M ATERIAL SIZE	TUBING I.D. S	
					ROUND	SQUARE
JJ-100		4.75	3.81	.46x4.78	17/19	17/19
JJ-130	(0203-250-28)	6.35	7.11	.55x6.35	11/15.5	10.2/15.5
JJ-131		6.35	7.11	.55x6.35	18/22	18/22
JJ-150	(0203-312-37)	7.92	9.40	.64x7.92	14/22	11.5/22
JJ-180	(0203-375-37)	9.53	9.40	.64x9.53	15.3/23.5	14.3/22

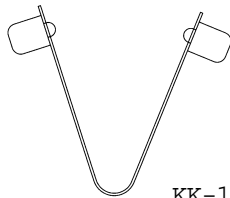

KK-130

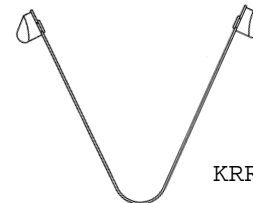

KRR-166

P/N	OLD P/N	H D DIA.	HD. HGT.	M ATERIAL SIZE	TUBING I.D. S	
					ROUND	SQUARE
KK-130	(0201-250-28)	6.35	7.11	.55x6.35	18.1/25	17.3/25
KK-131		6.35	6.35	.55x7.92	16/25	16/25
KK-132		6.35	7.11	.46x9.27	19.1/20	19.1/20
KK-133		6.35	8.64	.55x6.35	22/25	22/25
KK-150	(0201-312-37)	7.92	9.40	.64x7.92	24.4/34	24.4/34
KK-180	(0201-375-37)	9.53	9.40	.76x9.53	24.2/50.5	24.2/50.5
KRR-166		9.53 (ramp)	8.64	.76x9.53	29.3/55.5	29.3/55.5
KRR-167		9.53 (ramp)	10.31	.76x9.53	25.4/47.5	25.4/47.5

BUTTON HEAD - T303 STAINLESS
 SPRINGS - T301 STAINLESS



Made exclusively by VALCO^{fi} VALLEY TOOL & DIE, INC.

10020 York Theta Drive, North Royalton, Ohio 44133

(440) 237-0160 Fax (440) 237-0089 Website: <http://www.valcocleve.com>

VALCO^{fi} SNAP-BUTTON L-LATCH TYPE

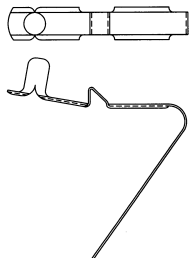

L-130

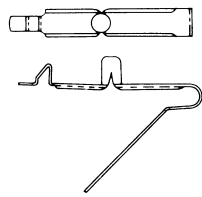

L-135

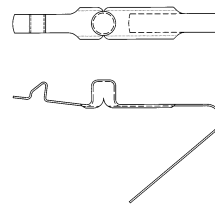

L-180

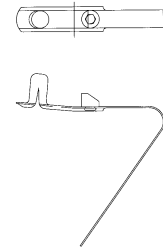

LL-130

P/N	HD DIA.	HD. HGT.	CENTER DISTANCE	RAMP TYPE	RAMP SIZE DIA (WIDTH) . x HGT.	TUBING I.D. s ROUND	TUBING I.D. s SQUARE
L-130	6.35	10.80	18.42	Formed	6.35x5.08	14/28	13.3/28
L-135	6.35	9.53	22.23	Formed	4.57x6.35	16/19	16/19
L-180	9.27	9.53	25.40	Formed	7.13x6.86	16/31.5	13.3/31.5

P/N	HD DIA.	HD. HGT.	CENTER DISTANCE	RAMP TYPE	RAMP SIZE DIA (WIDTH) . x HGT.	TUBING I.D. s ROUND	TUBING I.D. s SQUARE
LL-130	6.35	10.80	19.05	Solid brass	6.35x4.75	14/28	13.3/28
LL-131	6.35	10.80	19.05	Solid brass	6.35x5.08	14/28	13.3/28
LL-132	6.35	10.80	10.80	Solid brass	6.35x6.35	14/28	13.3/28
LL-133	6.35	10.80	19.05	Solid brass	6.35x7.92	16/28	16/28
LL-134	6.35	10.80	19.05	Solid brass	6.35x4.75	18/28	18/28
LL-135	6.35	9.53	22.10	Solid brass	6.35x4.75	16/19	15/19
LL-136	6.35	7.92	41.28	Solid brass	6.35x4.75	22.1/47.5	22.1/47.5
LL-137	6.35	6.35	25.40	Solid brass	6.35x4.75	13/22	13/22
LL-138	6.35	6.35	22.23	Solid brass	6.35x4.75	13/22	13/22

P/N	HD DIA.	HD. HGT.	FEATURES	RAMP TYPE	RAMP SIZE DIA (WIDTH) . x HGT.	TUBING I.D. s ROUND	TUBING I.D. s SQUARE
LD-100-X	6.60	4.95	Double end	Formed 2x	4.57x4.57	13/18	12/18
LR-180	9.27	9.53	Contoured ramp	Solid steel	9.53x7.87	16/22	13/22
LFC-130	6.35	10.31	Solid flat button	Formed	6.35x7.06	13 min.	13 min.

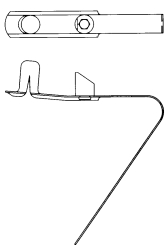

LL-131
LL-133
LL-134

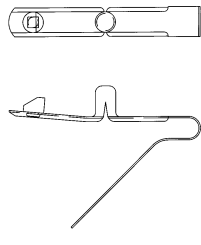

LL-135

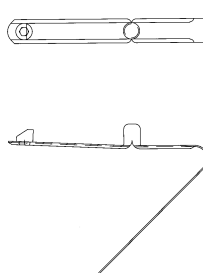

LL-136
LL-138

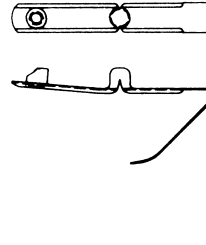

LL-137

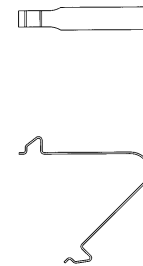

LD-100-X

ALL VALCO^{fi} SNAP-BUTTONS are 1050 Spring Steel and .0051 Zinc Plated minimum, unless otherwise noted. For items plated otherwise:

- Specify:
- B = Black Zinc finish
 - G = Zinc/Gold Dichromate finish
 - N = Nickel plated finish, e.g. L-130-N
 - X = Standard item in 410 Stainless Steel
 - D = Dome Head
 - S = Standard item with steel insert crimped in button head

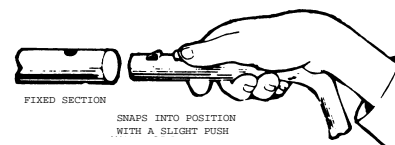

FIXED SECTION
SNAPS INTO POSITION
WITH A SLIGHT PUSH

How the Valco Dual Snap-Button and Valco Latch Button Work.



Made exclusively by VALCO^{fi} VALLEY TOOL & DIE, INC.

10020 York Theta Drive, North Royalton, Ohio 44133

(440) 237-0160 Fax (440) 237-0089 Website: <http://www.valcocleve.com>

VALCO^{fi} SNAP-BUTTON ASSEMBLIES

FEATURE SOLID BUTTON HEADS

RIVETED TO HEAT-TREATED LEAF SPRING

P/N SPECIAL SQUARE	H D		M ATERIAL	TUBING I.D. S		SIZE ROUND
	FEATURES			DIA.	HGT.	
AC -100	4.75	9.53	.76x8.89	38.1/50.5	38.1/50.5	
AC -101	4.75	3.81	.76x6.48	8/12.5	8/12.5	
AC -102	4.75	3.78	.51x4.57	7/11	6.1/11	Short Button Leg
AC -120	5.99	6.00	.51x6.35	10.2/19	10.2/19	
AC -130	6.35	7.11	.55x6.35	11/22	10.5/22	
AC -131	6.35	5.59	.55x6.35	10/22	10/22	
AC -132	6.35	9.40	.64x7.92	14/22	11/22	
AB -133	6.35	7.62	.51x6.35	19.1/22	19.1/22	
AB -134	6.35	7.62	.51x6.35	15.3/32	15.3/32	
AC -141	7.62	12.70	.64x8.89	32/44	32/44	
AC -142	7.62	12.70	.46x8.89	22.1/38	22.1/38	
AC -143	7.62	12.70	.51x8.89	22.1/38	22.1/38	
AC -150	7.92	9.40	.64x7.92	14/25	13/25	
AC -151	7.92	15.88	.51x9.27	22.4/38	22/38	
AC -152	7.92	12.70	.64x8.89	27/44	27/45	Dome Head
AC -153	7.87	7.14	.91x11.18	22.1/31.5	22.1/31.5	
AC -155	7.92	12.70	.51x11.18	17.1/31.5	16/31.5	
AC -156	8.03	8.13	.64x9.53	16.2/64	33.3/63.5	50.80 I.D. Tube
AC -170	9.27	9.40	.64x13.46	27/66.5	25.4/66.5	
AC -171	9.27	14.22	.64x13.46	27/66.5	25.4/66.5	
AC -172	9.27	14.22	.64x13.46	27/66.5	25.4/66.5	Flanged Heads
AC -173	9.27	14.22	.51x11.18	18.3/27.5	17.1/27.5	
AC -180	9.53	9.40	.76x9.53	15.3/28	14/28	
AC -190	12.70	14.22	.76x12.70	29/57	21/57	
AC -191	12.70	14.22	.76x12.70	38.1/63.5	38.1/63.5	
AC -181	9.53	9.40	.64x9.53	30/41	32/41.5	
AC -182	9.53	8.38	.55x11.18	15.3/35	14/35	
AC -183	9.53	8.38	.64x12.95	17/35.5	14/35.5	
AC -184	9.53	9.53	1.02x9.53	42/47.5	38.1/47.5	
AC -185	9.53	9.53	.76x12.70	38.1/53.5	38.1/53.5	
AC -187	9.53	11.18	.76x12.70	22/41	19.1/41	Full Radius Head
AC -190-D	12.70	15.49	.76x12.70	3/28	23/28	Full Radius Head
AC -186	9.53	9.53	.51x9.27	25.4/38	25.4/38	

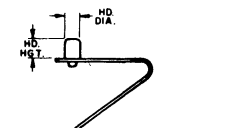

A -130

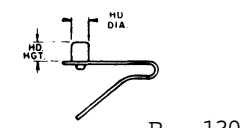

B -130

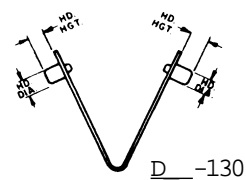

D -130

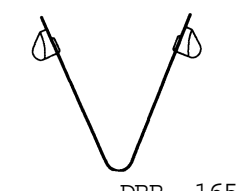

DRR -165

CODE :

AA-Part No. = Aluminum
 AB-Part No. = Brass
 AC-Part No. = Cold Drawn Steel
 AX-Part No. = Type 410
 Stainless Steel

eg: AA-130
 A=Style, A=Aluminum, 130=Size

BA-Part No. = Aluminum
 BB-Part No. = Brass
 BC-Part No. = Cold Drawn Steel
 BX-Part No. = Type 410
 Stainless Steel

DA-Part No. = Aluminum
 DB-Part No. = Brass
 DC-Part No. = Cold Drawn Steel
 DX-Part No. = Type 410
 Stainless Steel

Button Heads can be made from any free machining type material; generally Steel, Brass or Aluminum. Standard finish on steel button heads is Zinc plating. Leaf Spring thickness and width may be varied to fit the applications.

* BC-142 comes standard with case hardened steel button head and Zinc plating.



Made exclusively by VALCO^{fi} VALLEY TOOL & DIE, INC.
 10020 York Theta Drive, North Royalton, Ohio 44133
 (440) 237-0160 Fax (440) 237-0089 Website: <http://www.valcocleve.com>

VALCO^{fi} SNAP-BUTTON ASSEMBLIES

FEATURE SOLID BUTTON HEADS

RIVETED TO HEAT-TREATED LEAF SPRING

P/N SPECIAL SQUARE	HD		MATERIAL	TUBING I.D. S		SIZE ROUND
	FEATURES			DIA.	HGT.	
BC_-130	6.35	7.11	.55x6.35	11/15.5	10.2/15.5	
BC_-142	7.67	9.40	.51x11.18	14/22	11.5/22	
BC_-150	7.92	9.40	.64x7.92	14/22	11.5/22	
BC_-151	7.92	9.40	.51x11.18	15.3/23.5	14.3/22	
BC_-160	9.27	12.70	.64x9.53	20.4/25	19.1/25	Dog Leg
BC_-161	9.27	6.48	.64x9.53	11/22	10.2/22	Dog Leg
BC_-180	9.53	9.40	.64x9.53	15.3/23.5	14.3/22	
BB_-100	4.75	5.08	.31x6.60	10.2/19	10.2/19	
BB_-101	4.75	5.08	.51x6.35	11.5/19	11.5/19	
*BC_-141	7.67	9.53	.51x11.18	16/19	16/19	
BR_-100	4.75	6.99	.46x6.35	13/19	13/19	
DC_-130	6.35	7.11	.51x6.35	18.1/25	17.3/25	
DC_-131	6.35	7.14	.64x6.35	19.1/28	19.1/28	
DB_-132	6.35	8.38	.51x6.35	22.1/31.5	22.1/31.5	
DC_-133	6.35	11.10	.76x8.89	64/88.5	64/88.5	Large Radius
DC_-150	7.92	9.40	.64x7.92	24.2/31.5	24.2/31.5	
DC_-160	9.27	14.22	.64x13.46	33.1/41	24.2/38	
DRR_-165	9.53	7.87	.51x9.27	24.2/41	24.2/41	Ramp Heads
DC_-171	9.27	14.22	.64x13.46	38.1/57	38.1/57	
DC_-180	9.53	9.40	.76x9.53	24.2/50.5	24.2/50.5	
DC_-181	9.53	12.70	.76x12.70	41/50.5	41/50.5	
DC_-182	9.53	5.46	.76x12.70	32/50.5	32/50.5	Large Radius
DC_-183	9.53	9.53	.76x12.70	32/50.5	32/50.5	Large Radius
DC_-200	12.70	9.40	.76x17.27	25.4/41	25.4/41	
DX_-200	12.70	9.40	.76x17.27	25.4/41	28.5/41	
DC_-201	12.70	14.22	.76x12.70	44.5/53.5	40/60	

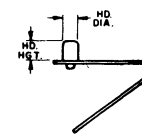

A_-130

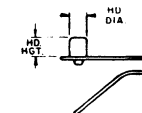

B_-130

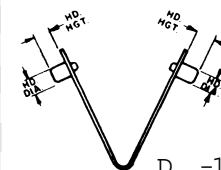

D_-130

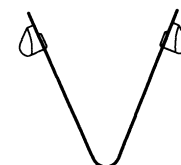

DRR_-165

CODE :

AA-Part No. = Aluminum
 AB-Part No. = Brass
 AC-Part No. = Cold Drawn Steel
 AX-Part No. = Type 410
 Stainless Steel
 eg: AA-130
 A=Style, A=Aluminum, 130=Size

BA-Part No. = Aluminum
 BB-Part No. = Brass
 BC-Part No. = Cold Drawn Steel
 BX-Part No. = Type 410
 Stainless Steel

DA-Part No. = Aluminum
 DB-Part No. = Brass
 DC-Part No. = Cold Drawn Steel
 DX-Part No. = Type 410
 Stainless Steel

Button Heads can be made from any free machining type material; generally Steel, Brass or Aluminum. Standard finish on steel button heads is Zinc plating. Leaf Spring thickness and width may be varied to fit the applications.

* BC-142 comes standard with case hardened steel button head and Zinc plating.



Made exclusively by VALCO^{fi} VALLEY TOOL & DIE, INC.

10020 York Theta Drive, North Royalton, Ohio 44133

(440) 237-0160 Fax (440) 237-0089 Website: <http://www.valcocleve.com>

VALCO^{fi} SNAP-BUTTON ASSEMBLIES

RAMP TYPE

FOR ONE-WAY LOCKING SELF-DEPRESSING OPERATION IN SQUARE OR RECTANGULAR TUBING APPLICATIONS

SOLID CONTOURED RAMP TYPE BUTTONS ASSEMBLED TO SPRING

P/N	RAMP DIA.	RAMP HGT.	MATERIAL SIZE	SQUARE TUBING I.D. RANGE
RR-130	6.35	5.59	.31x6.73	11.5/19
RR-150	7.92	8.00	.51x9.27	13/25
RR-151	7.92	7.75	.51x9.27	19.1/35
RR-152	7.92	7.75	.64x11.18	25.4/31.5
RR-153-L	7.92	7.92	.51x9.27	18/31.5
RR-160	9.53	8.00	.51x9.27	13/25
RR-161-AL	9.53	8.00	.38x7.92	13/19
RR-162	9.53	8.00	.51x12.95	19.1/31.5
RR-163	9.53	8.00	.51x9.27	11/25
RR-164	9.53	8.00	.51x9.27	11/25
RR-165	9.53	8.00	.51x9.27	11/25
RR-166	9.53	7.92	.46x9.27	20.4/31.5
RR-167	9.47	6.10	.51x12.95	19.1/31.5
RR-168	9.53	7.92	.51x9.27	19.1/31.5
RR-170	10.31	7.37	.51x9.53	13/25
HR-160	9.53	8.00	.38x10.67	12/16
HR-280	10.31	8.00	.38x10.67	13/19
HR-281	10.31	8.00	.38x12.70	14.3/19
HR-282	10.31	8.00	.64x12.95	15.3/22
HR-283	10.31	8.00	.64x12.95	20.4/38
HR-284	10.31	8.00	.64x12.95	Special Application

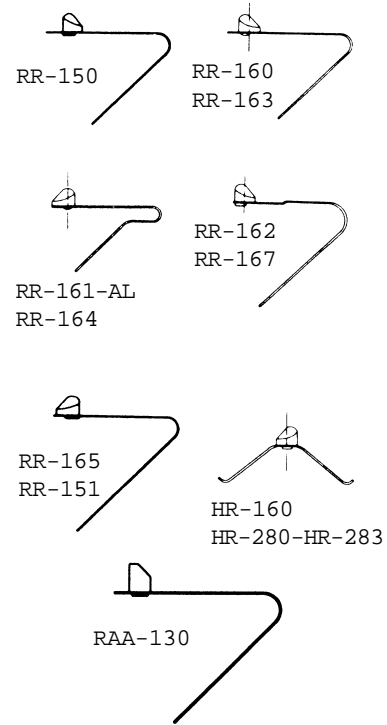

MILLED RAMP TYPE BUTTONS ASSEMBLED TO SPRING

P/N	RAMP DIA.	RAMP HGT.	MATERIAL SIZE	SQUARE TUBING I.D. RANGE
RAA-130	6.35	8.38	.46x9.27	19.1/35
RAA-180	9.53	6.35	.64x12.95	19.1/31.5
RAA-181	9.53	6.35	.51x12.95	19.1/31.5
RAA-182	9.53	6.60	.51x12.95	19.1/31.5
HR-182	9.53	6.35	.38x10.67	12/16
HR-183	9.53	9.14	.38x10.67	12/16
HR-184	9.53	6.35	.31x10.67	12/16
HR-185	9.53	6.35	.31x10.67	10.2/12
HR-186	9.53	6.35	.64x12.95	Special Application

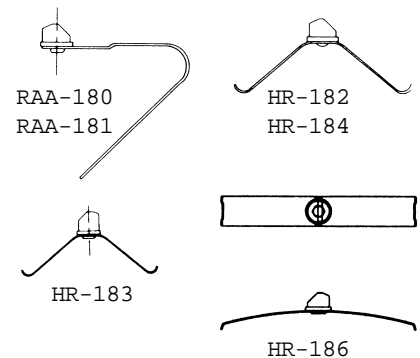

FLAT TYPE RAMP BUTTON

P/N	RAMP DIA.	RAMP HGT.	MATERIAL SIZE	HOLE DIA.	CENTER DISTANCE
FR-110	5.56	4.06	.51x10.67	3.68	39.62 in Flat
FR-111	5.54	4.06	.51x10.67	3.68	39.62
FR-130	6.35	4.57	.64x8.25	3.25	38.10
FR-131	6.35	8.38	.64x12.70	6.73	50.80
FR-160	9.47	7.87	.64x12.95	3.30	44.07
FR-180	9.53	9.14	.64x12.95	3.30	45.21
FR-181	9.53	9.14	.64x12.95	3.30	45.85
FR-182	9.14	9.53	.51x11.18	4.85	44.45
FRC-140	7.62	11.68	.64x12.95	3.25	25.40

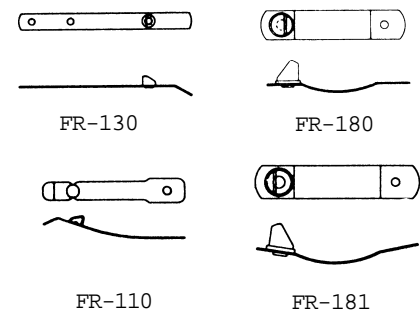

Made exclusively by VALCO^{fi} VALLEY TOOL & DIE, INC.

10020 York Theta Drive, North Royalton, Ohio 44133

(440) 237-0160 Fax (440) 237-0089 Website: <http://www.valcocleve.com>

VALCO^{fi} SNAP-BUTTON

W- WITH SOLID BUTTON HEADS AND
GALVANIZED MUSIC WIRE SPRING

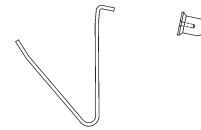

P/N	HD		TUBING I.D. S		STANDARD SPRING DIAMETER	SPRING PART NO.	BUTTO N PART NO.
	DIA.	HGT.	ROUND	SQUARE			
W_-100	4.75	5.33	8.2/14	8/14	.91	WS-100	1932
W_-120	5.56	5.59	8.4/14	8.4/14	.91	WS-100	1892
W_-125	6.35	4.57	8.4/14	8.4/14	.91	WS-100	1921
W_-130	6.35	7.11	10.2/14	10.2/14	.91	WS-100	1933
W_-132	6.35	7.11	11.5/22	11.5/22	.91	WS-101	1933
W_-133	6.35	7.11	28/40	28/40	.91	WS-102	2281
W_-150	7.92	9.40	13.5/31.5	13/31.5	1.52	WS-200	1934
W_-151	7.92	7.87	17/25.5	17/25.5	1.22	WS-150	2201
W_-152	7.92	9.40	21.1/30	21.1/30	1.52	WS-200	1934
W_-160	9.14	8.89	14/25	13/25	1.52	WS-200	1817
WB_-161	9.19	8.89	14/25	13/25	1.52	WS-200-X	1991-B
WN_-161	9.27	13.72	28/33	28/33	1.52	WS-200-X	2036-N
W_-180	9.53	9.40	14/25	13.3/25	1.52	WS-200	1935

Button heads can be made from any free machining material.

CODE: WA-Part Number = Aluminum
 WB-Part Number = Brass
 WC-Part Number = Cold Drawn Steel
 WX-Part Number = Stainless Steel
 WN-Part Number = Nylon

Wire Spring can be made from Stainless Steel. Special sizes and shapes can be made to your print. Standard finish on steel button heads is Zinc plating.

e.g. WC-130 = A steel button head, Zinc plated, is furnished along with a galvanized music wire spring.

SPECIAL WIRE BUTTONS

P/N	HD		TUBING I.D. S		STANDARD SPRING DIAMETER	SPRING PART NO.	BUTTO N PART NO.
	DIA.	HGT.	ROUND	SQUARE			
WA-131	6.35	13.82	22/33	22/33	1.52	WS-210	2096
WA-140	7.62	7.11	13/28	13/28	1.52	WS-200	2214
WSB-050	3.30	5.33	10/20	10/20	1.22	One Piece	N/A

DOUBLE WIRE BUTTONS

P/N	HD		TUBING I.D. S		STANDARD SPRING DIAMETER	SPRING PART NO.	BUTTO N PART NO.
	DIA.	HGT.	ROUND	SQUARE			
WDA-125	6.35	4.83	15/25	15/19	.91	WDS-100	1921-A
WDA-130	6.35	7.11	20/25	20/25	.91	WDS-100	1933-A
WDA-131	6.35	7.11	19.1/28	19.1/28	.91	WDS-101	1933-A
WDB-231	6.35	6.60	19/28	19/28	1.52	WDS-201	2046-B
WDC-225	6.35	4.57	14.3/19	14.3/19	1.52	WDS-200	1930-C



Made exclusively by VALCO^{fi} VALLEY TOOL & DIE, INC.

10020 York Theta Drive, North Royalton, Ohio 44133

(440) 237-0160 Fax (440) 237-0089 Website: <http://www.valcocleve.com>

INTRODUCING VALCO^{fi} PLASTIC SNAP-BUTTON

WILL NOT RUST
SMOOTH QUIET OPERATION
EASIER INSTALLATION
FOR USE IN LIGHTER LOAD APPLICATIONS
LIGHTER IN WEIGHT
MORE COST EFFECTIVE

VALCO^{fi} PLASTIC SNAP-BUTTONS are available in Delrin Nylon and PVC material. Custom colors are available per your request at an additional charge.

VALCO^{fi} PLASTIC SNAP-BUTTONS are produced with the same precision and quality that our customers receive from our steel products. The versatility and flexibility of this new product line allows VALCO^{fi} to provide its customers with a wider range of products to fulfill their needs.

VALCO^{fi}'s Engineering staff is always willing to consult and assist with your individual application needs.

Please call our Sales Department for price quotes.

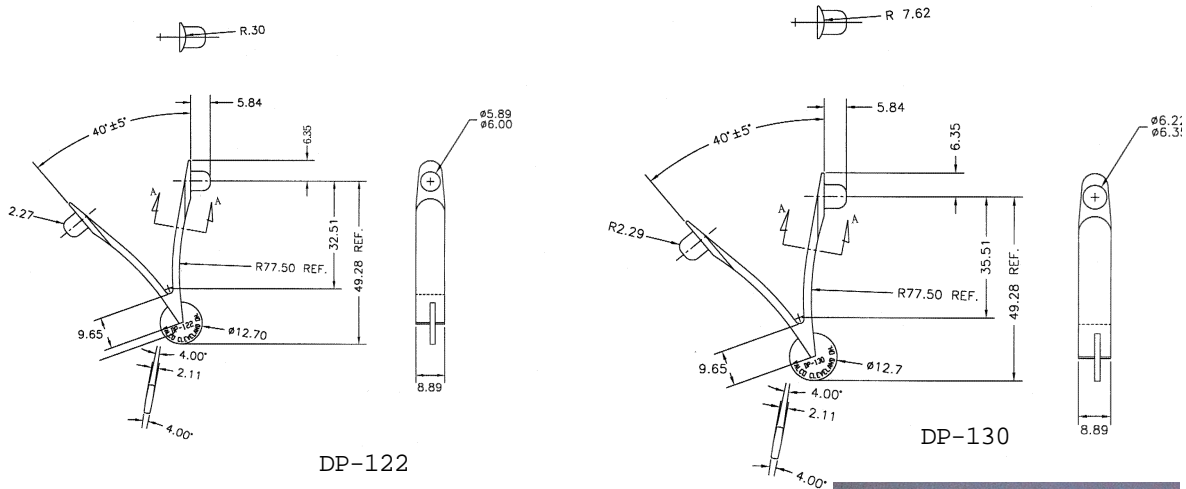

P/N	BUTTON HEAD	BUTTON HEAD	TUBING I.D.	
	DIAMETER	HEIGHT	ROUND	SQUARE
DP-122	6	5.8	16.0/20.3	15.7/ 20.3
DP-130	6.4	5.8	16.0/20.3	15.7/ 20.3



VALCO^{fi} SNAP-BUTTON

M - MINING DRILL-BIT RETAINING CLIP

Material: 1074 Spring Steel

P/N	HD. DIA.	HD. HTS.	MATERIAL SIZE	LENGTH
M-100	4.57	6.07	.460x6.80	13.97
M-100-S	4.57	6.07	.460x6.80	13.97
M-101	4.57	6.07	.460x6.80	12.19
M-101-S	4.57	6.07	.460x6.80	12.19
M-102	4.57	6.07	.460x6.80	12.22
M-103	4.57	6.07	.460x6.48	11.94
M-104	4.57	6.07	.460x6.48	16.26
M-180	9.40	9.40	.635x12.95	38.10

Specify: -B = Black Zinc finish
 -G = Zinc/Gold Dichromate finish
 -S = Standard item with steel insert crimped in button head e.g. M-100-B or M-100-B-S

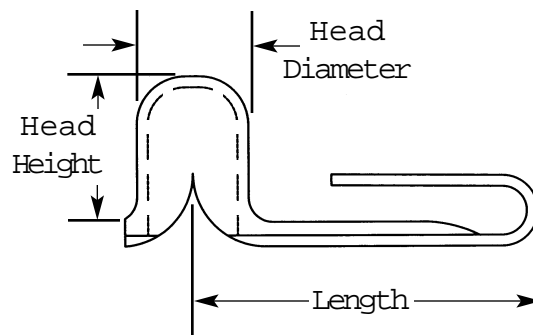

VALCO^{fi} DUST HOG V CLIP

Material: C-1050 -74 Spring Steel

P/N	DRILL STEEL	MATERIAL SIZE
M-120	22.23	.51x6.6
M-121	28.56	.51x8.9

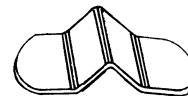

Standard Finish: Black Oxide



Made exclusively by VALCO^{fi} VALLEY TOOL & DIE, INC.

10020 York Theta Drive, North Royalton, Ohio 44133

(440) 237-0160 Fax (440) 237-0089 Website: <http://www.valcocleve.com>

VALCO^{fi} PIGGY BACK

DRILL BIT RETAINER

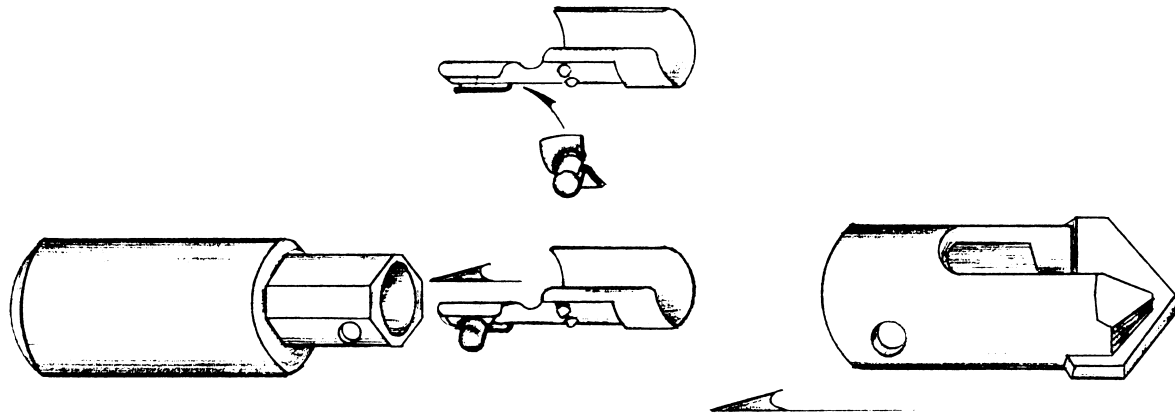

For 25.40 Drill Bits with 12.70 I.D. in the Drill Extension

P/N	SPRING P/N	BUTTON P/N	BUTTON DIA	BUTTON HGT.
M-112	M-111	M-110	4.75	4.62
M-112-S	M-111	M-110-S	4.75	4.62

For 34.93 Drill Bits with 17.46 I.D. in the Drill Extension

P/N	SPRING P/N	BUTTON P/N	BUTTON DIA	BUTTON HGT.
M-115	M-114	M-113	4.75	5.51
M-115-S	M-114	M-113-S	4.75	5.51

DRILL STEEL CHUCK

WEDDING BAND SPRING CLIPS

P/N	DRILL STEEL	ID.	MATERIAL SIZE
M-150	22.23	14.29	.64x9.65
M-151	22.23	14.29	.64x6.35
M-200	28.58	19.05	.76x12.70
M-201	28.58	19.05	.64x6.35

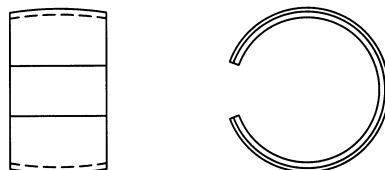

Made exclusively by VALCO^{fi} VALLEY TOOL & DIE, INC.

10020 York Theta Drive, North Royalton, Ohio 44133

(440) 237-0160 Fax (440) 237-0089 Website: <http://www.valcocleve.com>

VALCO^{fi} LOOP SPRINGS

SIMPLIFY YOUR TUBULAR PRODUCT, TIE-DOWN
OR ATTACHMENT NEEDS.

ELIMINATE EXPENSIVE EYEBOLTS.

INSTALLS QUICKLY WITH A SNAP!

MADE OF SPRING STEEL HEAT TREATED AND ZINC PLATED.

WILL ACCEPT UP TO 6.35 ROPE
OR HOOK FASTENERS.

VALCO^{fi} SINGLE LOOP SPRING

P/N LPS-250

FTIS: 29 TO 44 I.D.
ROUND OR SQUARE
TUBING

ONE 12.70 ROUND OR 9.53
SQUARE HOLE REQUIRED FOR
LOOP

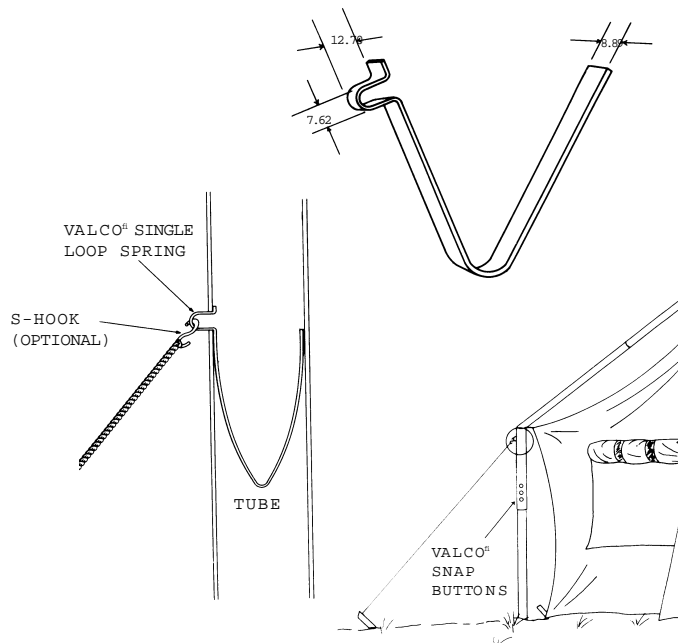

VALCO^{fi} DOUBLE LOOP SPRING

P/N LPD-250

FTIS: 29 TO 44 I.D.
ROUND OR SQUARE TUBING

TWO 12.70 ROUND OR 9.53
SQUARE HOLES REQUIRED
FOR LOOP

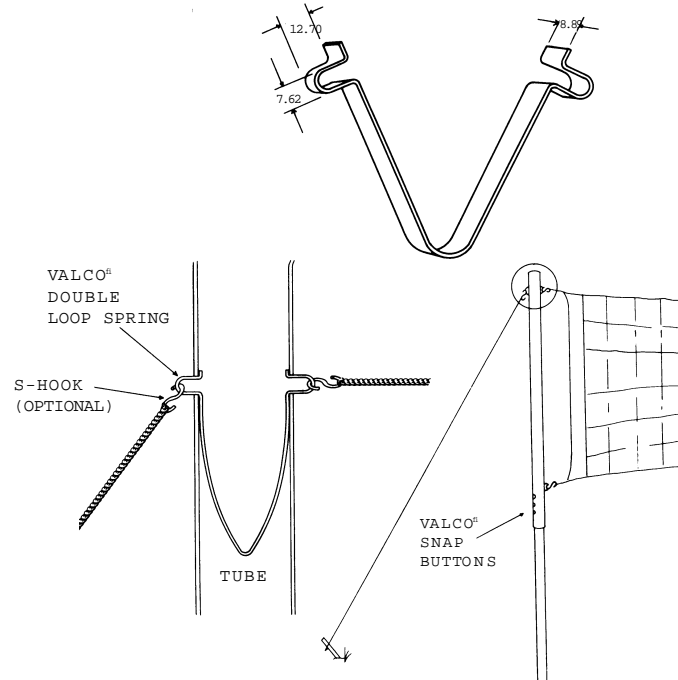

VALCO^{fi} CUBE STOPS FOR GARMENT RACKS!

P/N #1740

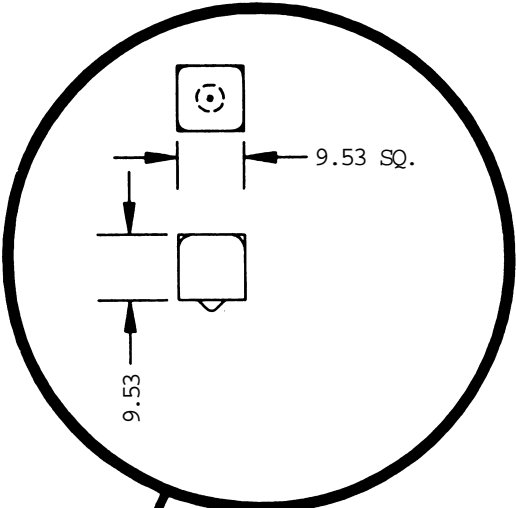

WELDS EASILY TO TUBING

MADE FROM COLD DRAWN
STEEL

TUMBLE POLISHED FOR BETTER
FINISH

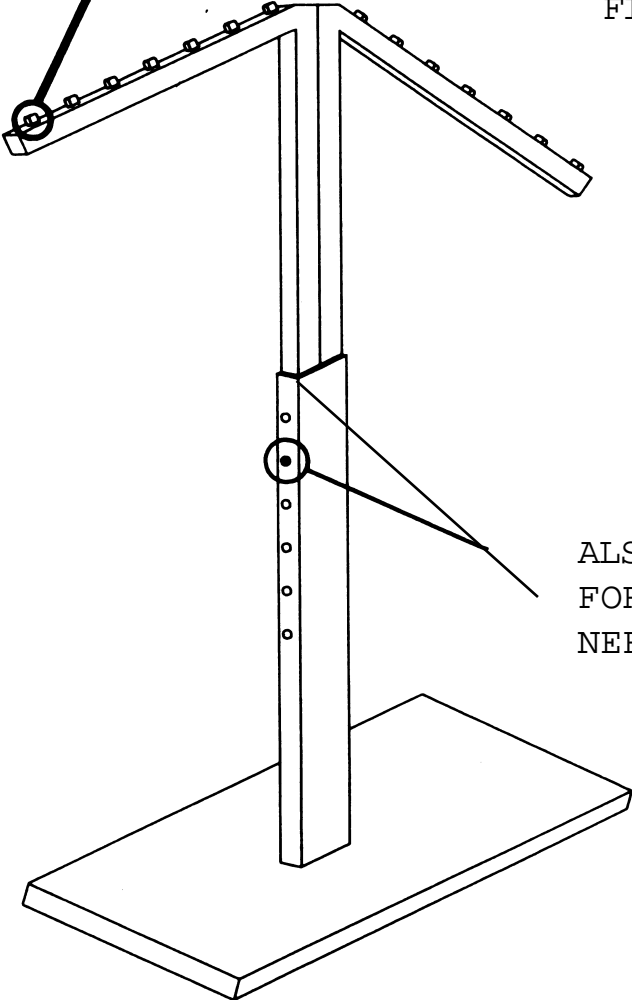

ALSO VALCO^{fi} SNAP BUTTONS
FOR YOUR TUBING ADJUSTMENT
NEEDS!



NEW VALCO^{fi} SIGN HANGERS PUT AN END TO FLY AWAY SIGNS!

Valco's new clasp lock design prevents our hangers from opening up in extreme wind conditions.

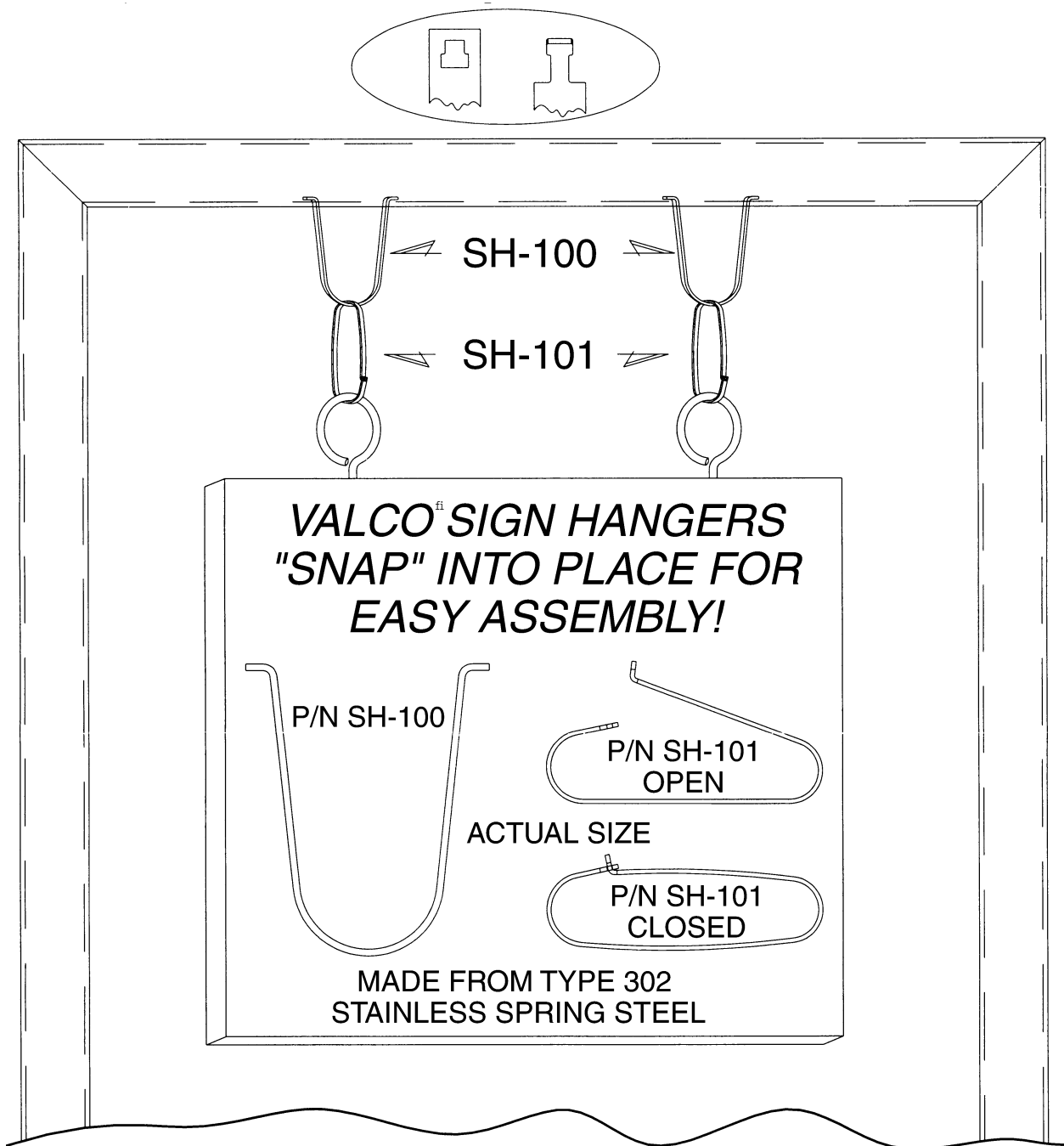

Made exclusively by VALCO^{fi} VALLEY TOOL & DIE, INC.

10020 York Theta Drive, North Royalton, Ohio 44133

(440) 237-0160 Fax (440) 237-0089 Website: <http://www.valcocleve.com>

NEW VALCO^{fi} SPRING PLUNGERS

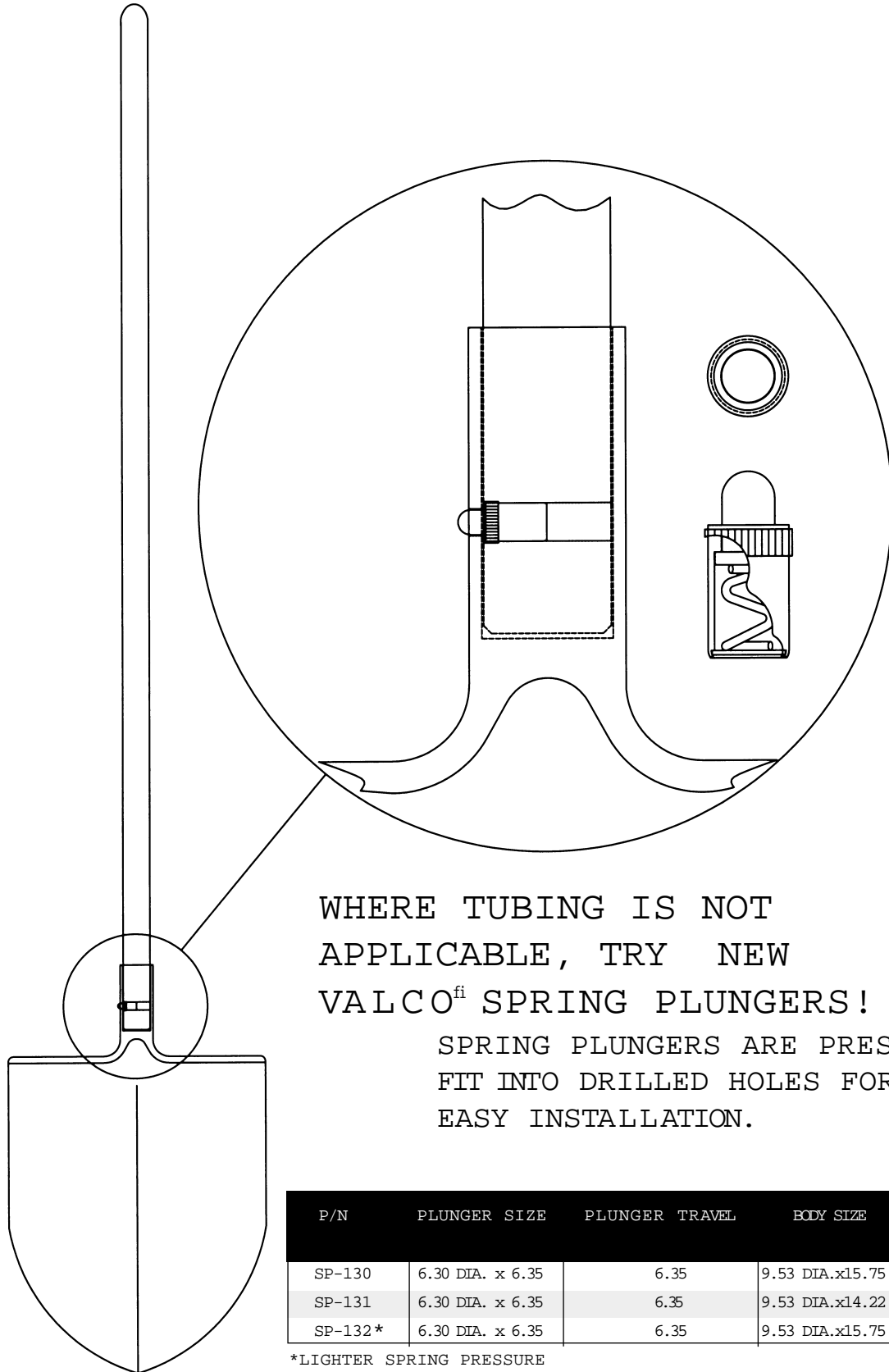

WHERE TUBING IS NOT
APPLICABLE, TRY NEW
VALCO^{fi} SPRING PLUNGERS!

SPRING PLUNGERS ARE PRESS-
FIT INTO DRILLED HOLES FOR
EASY INSTALLATION.

P/N	PLUNGER SIZE	PLUNGER TRAVEL	BODY SIZE	SPRING RATE INITIAL / FINAL
SP-130	6.30 DIA. x 6.35	6.35	9.53 DIA.x15.75	.45kg. / 1.36kg.
SP-131	6.30 DIA. x 6.35	6.35	9.53 DIA.x14.22	.45kg. / 1.36kg.
SP-132*	6.30 DIA. x 6.35	6.35	9.53 DIA.x15.75	.23kg. / .656kg.

*LIGHTER SPRING PRESSURE



Made exclusively by VALCO^{fi} VALLEY TOOL & DIE, INC.

10020 York Theta Drive, North Royalton, Ohio 44133

(440) 237-0160 Fax (440) 237-0089 Website: <http://www.valcocleve.com>

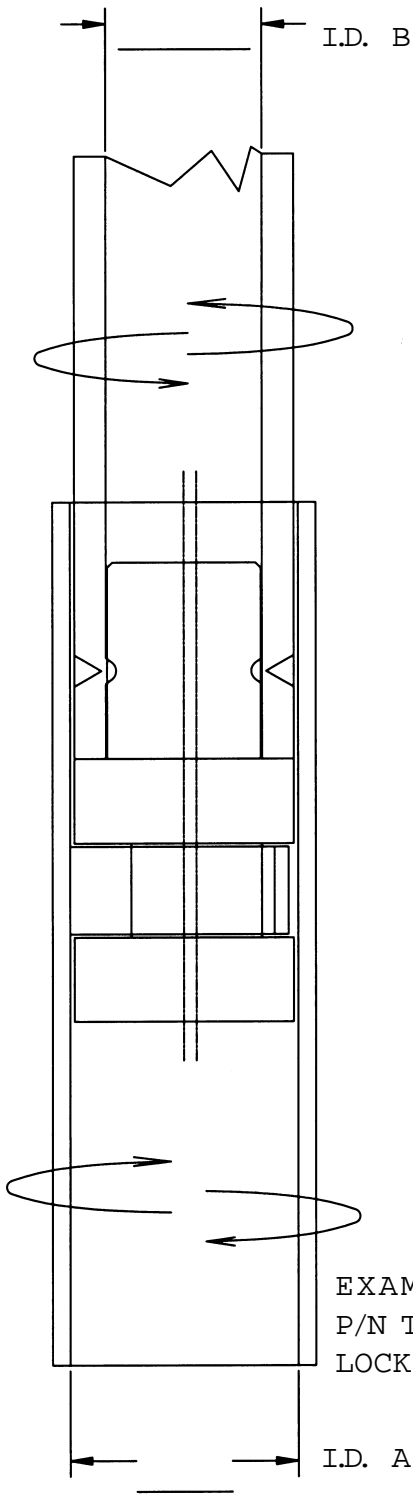

NEW VALCO^{fi} TWIST LOCK PLUGS

VALCO S NEW TWIST LOCK PLUGS LET YOU ADJUST TELESCOPIC TUBING TO ANY LENGTH BY SIMPLY TWISTING FIRMLY.

FILL IN TUBE INSIDE DIAMETERS A & B AND FAX US FOR A QUOTATION. FAX # (440) 237-0089

EXAMPLE
P/N TL-4362
LOCKS 11 I.D. TUBE INTO 16 I.D. TUBE

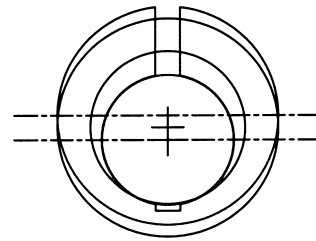
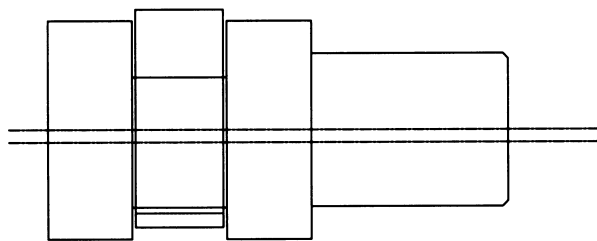

P/N TL-4362
EXAMPLE



Made exclusively by VALCO^{fi} VALLEY TOOL & DIE, INC.

10020 York Theta Drive, North Royalton, Ohio 44133

(440) 237-0160 Fax (440) 237-0089 Website: <http://www.valcocleve.com>

Let VALCO^{fi} supply your stamping requirements with the highest quality precision-made products at competitive prices

PROGRESSIVE DIE STAMPINGS

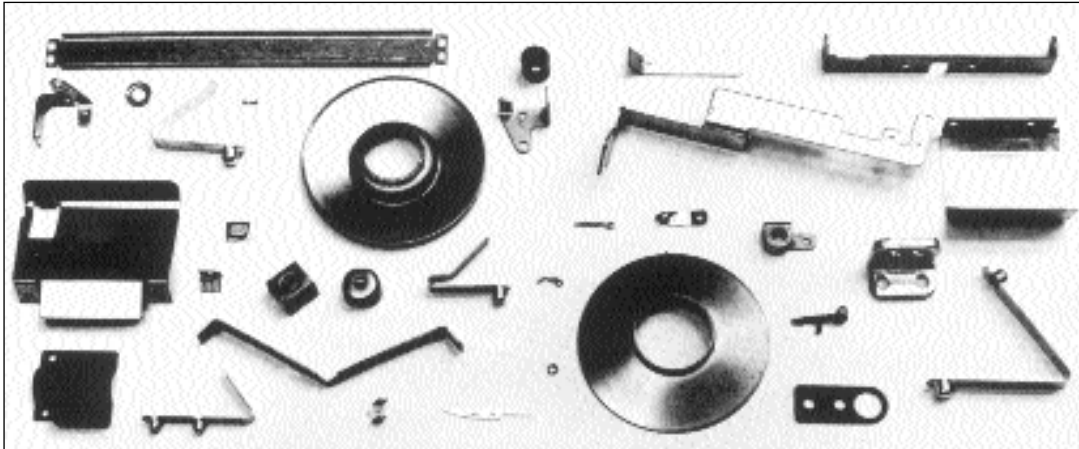

FOUR SLIDE STAMPINGS

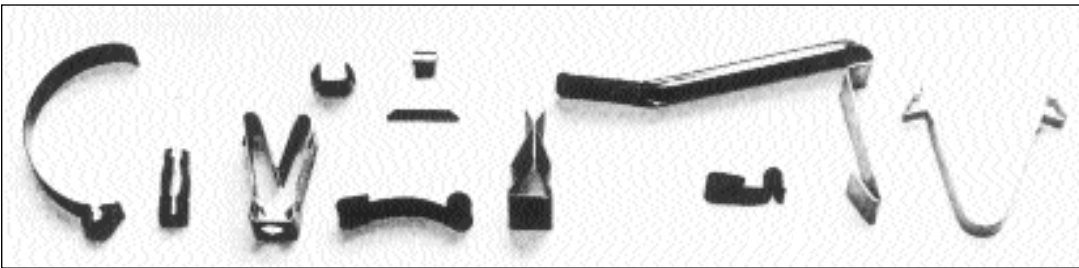

ASSEMBLIES

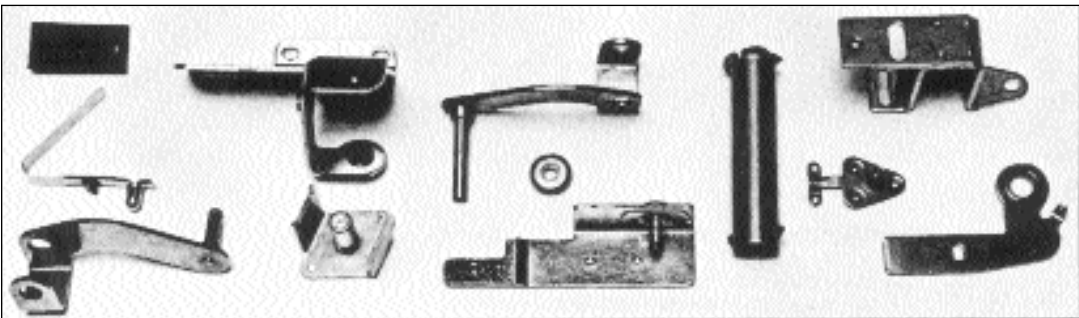

In addition, we provide secondary operations including Drilling, Tapping, Spot Welding and many others.

All tools and dies are designed and produced in our comprehensive tooling department. When required, our engineering staff will help design and develop parts to your exact specifications.

FOR PROMPT EXECUTIVE ATTENTION TO YOUR ORDERS, CALL:



Made exclusively by VALCO^{fi} VALLEY TOOL & DIE, INC.
10020 York Theta Drive, North Royalton, Ohio 44133
(440) 237-0160 Fax (440) 237-0089 Website: <http://www.valcocleve.com>

VALCO^{fi} can help you maintain your high standards of quality with a comprehensive range of screw machine parts and services including:

MILLING, DRILLING, TAPPING, COUNTERSINKING, BRAZING, POINTING, KNURLING, HEAT TREATING AND PLATING.

A variety of our screw machine products are illustrated below.



VALCO^{fi} is fully staffed and equipped to design and manufacture any combination of a screw machine part and a metal or plastic stamping assembly.

Let us quote on your requirements. Call:



Made exclusively by VALCO^{fi} VALLEY TOOL & DIE, INC.

10020 York Theta Drive, North Royalton, Ohio 44133

(440) 237-0160 Fax (440) 237-0089 Website: <http://www.valcocleve.com>

VALCO^{fi} VALLEY TOOL & DIE, INC.

TERMS OF SALES

Any Agreement, order of Sale of goods or services referenced is expressly limited to and made conditional upon the terms and conditions herein, and any of the Buyer's terms in addition to or different from those contained herein, whether added to this form or contained in any purchase order, acknowledgement or confirmation prepared by Buyer, sent to Valco^{fi}/Valley Tool & Die, Inc. (Valco^{fi}), are hereby objected to and shall be of no effect.

(1) Cancellation. Any order placed for the goods or services listed may not be canceled by Buyer, except upon terms agreeable to Valco that will fully compensate Valco^{fi} for all expenses incurred by Valco^{fi} to the date of cancellation, together with any lost profits Valco^{fi} would have realized on such canceled order.

(2) Prices. All prices are quoted without consideration of taxes, and all taxes applicable to any order placed hereunder, including, but not limited to, Ohio or other applicable sales or use taxes, are additional and shall be paid by Buyer. All prices are F.O.B. Valco's plant, North Royalton, Ohio. All freight and shipping shall be the responsibility of the Buyer.

(3) Payment. Payment in full is due net within 30 days from the date of the invoice.

(4) Delivery Date. The delivery dates are approximate. Valco^{fi} can take no responsibility and shall not be deemed to be in default of any of its obligations due to any delays caused by acts of God, fires, floods, strikes, work stoppages, equipment failure, accidents, allocation, or other controls or regulations, of federal, state or local government, shortages of cars, fuels, materials or labor, or any other cause beyond its reasonable control.

(5) Claims. All claims of any nature shall be barred unless notice thereof is given to Valco^{fi} at its address set forth in writing by certified or registered mail, postmarked within ten days after receipt of the goods, and the goods relating to such claims are held intact and properly protected, unless instructed otherwise by Valco^{fi}, pending inspection by Valco's authorized inspector.

(6) Transportation and Risk of Loss. Upon delivery to a common carrier or to Buyer or Buyer's agent or representative of any material or goods owned by or made for Buyer, risk of loss or damage to such material or goods shall pass to Buyer, and Valco^{fi} shall have no further liability therefor.

(7) Insolvency. Valco^{fi} shall have the unrestricted right to cancel, withhold or delay its performance or delivery hereunder in the event of the happening of any of the following or any other comparable events, in which event Valco^{fi} shall have no liability for any losses or damages claimed by Buyer: (i) Buyer's insolvency or commission of an act of bankruptcy; (ii) commencement of proceedings by, for or against Buyer under any law relating to bankruptcy or the relief of debtors; (iii) the appointment of a receiver or trustee for Buyer; (iv) the execution of Buyer of an assignment for the benefit of the creditors; and (v) the determination by Valco^{fi} in its sole judgment, that Buyer's financial condition is such as to endanger its performance hereunder.

(8) Limited Warranty. Valco^{fi} warrants that all goods sold pursuant hereto shall conform to the specification set forth or to Valco's printed specifications for such goods, where applicable, or, where applicable, to written plans and specifications approved by both Valco^{fi} and the Buyer. THE AFORESAID IS THE SOLE WARRANTY GIVEN BY VALCO^{fi}, AND THERE ARE NO WARRANTIES, EXPRESS, IMPLIED OR STATUTORY, INCLUDING WARRANTIES OF MERCHANTABILITY AND FITNESS FOR USE, WHICH EXTEND BEYOND THE AFORESAID WARRANTY.

(9) Limitations of Remedy. BUYER'S SOLE REMEDY FOR ANY ALLEGED BREACH OF ANY OF VALCO'S WARRANTIES OR OBLIGATIONS HEREUNDER SHALL BE FOR VALCO^{fi}, AT VALCO'S SOLE OPTION, TO REPLACE OR REPAIR ANY DEFECTIVE OR NON-CONFORMING GOODS OR TO REFUND TO BUYER THE PURCHASE PRICE FOR ANY DEFECTIVE OR NON-CONFORMING GOODS.

(10) Limitation of Liability. VALCO'S LIABILITY WITH RESPECT TO ANY BREACH HEREUNDER OR RELATING TO ANY GOODS SOLD PURSUANT HERETO SHALL BE LIMITED TO THE AMOUNT PAID BY BUYER FOR ANY DEFECTIVE OR NON-CONFORMING GOODS. UNDER NO CIRCUMSTANCES SHALL VALCO^{fi} BE LIABLE FOR ANY INCIDENTAL OR CONSEQUENTIAL DAMAGES OR FOR ANY CLAIMS FOR LOST PROFITS.

(11) Complete Agreement. Any dispute which may arise from any agreement, order or sale based upon a quotation shall be governed by the laws of the State of Ohio.

(12) Governing Law. Any dispute which may arise from any agreement, order or sale based upon a quotation shall be governed by the laws of the State of Ohio.

(13) Disputes. No litigation arising from or relating to the manufacture, delivery, sale or performance of the goods or services referred to may be prosecuted against Valco^{fi} in any courts other than those located in Cuyahoga County, Ohio. Buyer consents to jurisdiction and venue in Cuyahoga County, Ohio.

In no event may any claim by Buyer for breach of any agreement or order of sale arising be brought in any court more than one year after the date of delivery of the date of any alleged breach, whichever shall be earlier.

(14) Headings. The headings used in this agreement are solely for the convenience of the parties and shall have no force or effect upon the interpretation of any provision hereof.



Made exclusively by VALCO^{fi} VALLEY TOOL & DIE, INC.

10020 York Theta Drive, North Royalton, Ohio 44133

(440) 237-0160 Fax (440) 237-0089 Website: <http://www.valcocleve.com>



VALCO[®] VALLEY TOOL & DIE, INC.
CREDIT APPLICATION FORM

COMPANY NAME _____

ADDRESS _____

CITY, STATE, ZIP _____

TELEPHONE NUMBER _____ FAX _____

HOW LONG IN BUSINESS _____ FEDERAL TAX ID _____

ESTIMATED ANNUAL SALES \$ _____ NUMBER OF EMPLOYEES _____

NAME OF OWNERS OR OFFICERS

NAME _____ TITLE _____

NAME _____ TITLE _____

TRADE REFERENCES

COMPANY NAME _____

TELEPHONE _____ FAX _____

COMPANY NAME _____

TELEPHONE _____ FAX _____

COMPANY NAME _____

TELEPHONE _____ FAX _____

COMPANY NAME _____

TELEPHONE _____ FAX _____

BANK REFERENCES

BANK NAME _____ ACCOUNT # _____

CONTACT _____ TELEPHONE _____

We certify that all information is correct and that we fully understand your credit terms are NET 30 days and agree to the proper payment in consideration of extended credit. If a violation of these terms persists, the applicant agrees to pay any collection costs incurred to collect the amount of balance, including reasonable attorney's fees.

SIGNATURE _____ DATE _____

PRINTED NAME _____ TITLE _____

Please return to:

Valco[®] Valley Tool & Die, Inc.
10020 York Theta Drive
North Royalton, OH 44133
Attention: Accounting

Phone: (440) 237-0161
Fax: (440) 237-0089
Web site: <http://www.valcocleve.com>



FRACTIONS – DECIMALS – MILLIMETERS

	<u>DECIMAL</u>	<u>MM</u>		<u>DECIMAL</u>	<u>MM</u>
	$\frac{1}{64}$.0156	0.396		$\frac{33}{64}$.5156	13.096
	$\frac{1}{32}$.0312	0.793		$\frac{35}{64}$.5312	13.493
	$\frac{3}{64}$.0468	1.190		$\frac{37}{64}$.5468	13.890
$\frac{1}{16}$	$\frac{5}{64}$.0625	1.587	$\frac{9}{16}$	$\frac{39}{64}$.5625	14.287
	$\frac{7}{64}$.0781	1.984		$\frac{41}{64}$.5781	14.684
	$\frac{3}{32}$.0937	2.381	$\frac{19}{32}$	$\frac{43}{64}$.5937	15.081
	$\frac{7}{64}$.1093	2.778		$\frac{45}{64}$.6093	15.478
$\frac{1}{8}$	$\frac{9}{64}$.125	3.175	$\frac{5}{8}$	$\frac{47}{64}$.625	15.875
	$\frac{11}{64}$.1406	3.571		$\frac{49}{64}$.6406	16.271
	$\frac{5}{32}$.1562	3.968	$\frac{21}{32}$	$\frac{51}{64}$.6562	16.668
	$\frac{11}{64}$.1718	4.365		$\frac{43}{64}$.6718	17.065
$\frac{3}{16}$	$\frac{13}{64}$.1875	4.762	$\frac{11}{16}$	$\frac{45}{64}$.6875	17.462
	$\frac{7}{32}$.2031	5.159		$\frac{47}{64}$.7031	17.859
	$\frac{15}{64}$.2187	5.556	$\frac{23}{32}$	$\frac{49}{64}$.7187	18.256
	$\frac{15}{64}$.2343	5.953		$\frac{51}{64}$.7343	18.653
$\frac{1}{4}$	$\frac{17}{64}$.250	6.350	$\frac{3}{4}$	$\frac{53}{64}$.750	19.050
	$\frac{17}{64}$.2656	6.746		$\frac{55}{64}$.7656	19.446
	$\frac{9}{32}$.2812	7.143	$\frac{25}{32}$	$\frac{57}{64}$.7812	19.843
	$\frac{19}{64}$.2968	7.540		$\frac{59}{64}$.7968	20.240
$\frac{5}{16}$	$\frac{21}{64}$.3125	7.937	$\frac{13}{16}$	$\frac{61}{64}$.8125	20.637
	$\frac{21}{64}$.3281	8.334		$\frac{63}{64}$.8281	21.034
	$\frac{11}{32}$.3437	8.731	$\frac{27}{32}$	$\frac{65}{64}$.8437	21.431
	$\frac{23}{64}$.3593	9.128		$\frac{55}{64}$.8593	21.828
$\frac{3}{8}$	$\frac{23}{64}$.375	9.525	$\frac{7}{8}$	$\frac{57}{64}$.875	22.225
	$\frac{25}{64}$.3906	9.921		$\frac{59}{64}$.8906	22.621
	$\frac{13}{32}$.4062	10.318	$\frac{29}{32}$	$\frac{61}{64}$.9062	23.018
	$\frac{27}{64}$.4218	10.715		$\frac{63}{64}$.9218	23.415
$\frac{7}{16}$	$\frac{27}{64}$.4375	11.112	$\frac{15}{16}$	$\frac{65}{64}$.9375	23.812
	$\frac{29}{64}$.4531	11.509		$\frac{67}{64}$.9531	24.209
	$\frac{15}{32}$.4687	11.906	$\frac{31}{32}$	$\frac{69}{64}$.9687	24.606
	$\frac{31}{64}$.4843	12.303		$\frac{71}{64}$.9843	25.003
$\frac{1}{2}$	$\frac{31}{64}$.500	12.700	1	$\frac{73}{64}$ 1.000	25.400



Made exclusively by VALCO VALLEY TOOL & DIE, INC.

10020 York Theta Drive, North Royalton, Ohio 44133

(440) 237-0160 Fax (440) 237-0089 Website: <http://www.valcocleve.com>

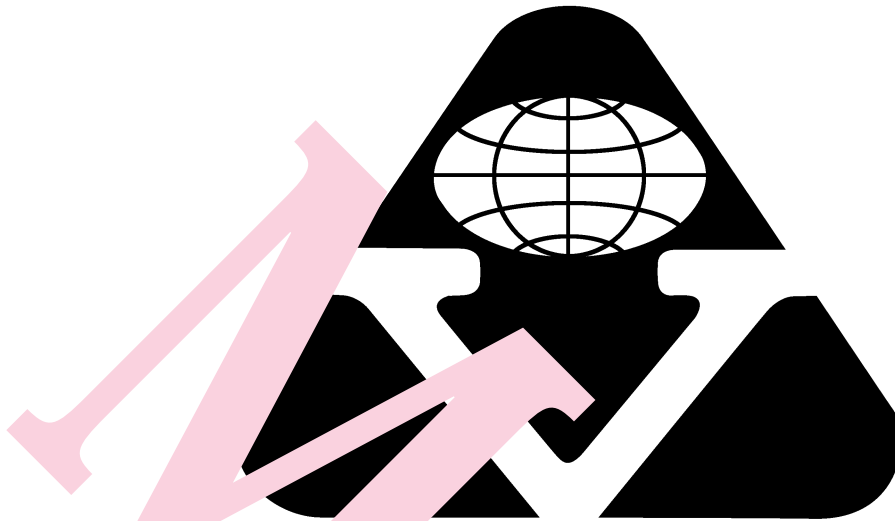

The Symbol of the highest Quality
stampings, assemblies and
made-to-order punch press
and screw machine products.

VALCO[®] / VALLEY TOOL & DIE, INC.

VALCO[®] / VALLEY TOOL & DIE, INC.

10020 York Theta Drive North Royalton, Ohio 44133 (440) 237-0160 Fax (440) 237-0089 Website: <http://www.valcocleveland.com>