

C-1102

Rigid Conduit Clamps

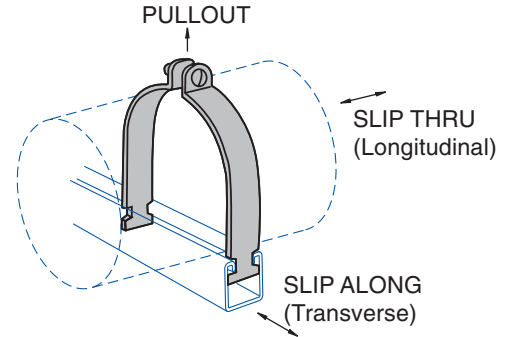

Pipe Size	O. D. Size	Steel Ga.	Wt./ 100 Pcs.	Std. Pkg.
3/8"	0.675	16	12	100
1/2"	0.840	16	13	100
3/4"	1.050	14	15	100
1"	1.315	14	18	100
1 1/4"	1.660	14	22	50
1 1/2"	1.900	12	32	50
2"	2.375	12	37	50
2 1/2"	2.875	12	42	50
3"	3.500	12	49	50
3 1/2"	4.000	11	65	25
4"	4.500	11	69	25
5"	5.563	11	82	20
6"	6.625	10	107	20
8"	8.625	10	133	Bulk
10"	10.75	10	143	Bulk

Nominal Pipe Size	Design Loads *		
	Slip Thru (lbs)	Slip Along (lbs)	Pullout (lbs)
1/2"	213	77	907
3/4"	142	169	992
1"	131	174	806
1 1/4"	354	150	1,160
1 1/2"	335	336	1,564
2"	405	506	1,572
2 1/2"	287	548	1,610
3"	496	452	1,317
3 1/2"	434	531	1,490
4"	518	576	1,505
5"	411	567	1,313
6"	406	563	1,531
8"	580	664	2,018

* Safety Factor 3.0

FINISH: Electro-Galvanized, other finishes available upon request.

ORDERING: Specify figure number and pipe size.

SPECIFICATIONS

GENERAL

H-STRUT Pipe Clamps are all manufactured to fit into the standard openings of 1 5/8" channel to support runs of piping where desired, to secure the pipe in place.

MATERIAL

H-STRUT pipe clamps are manufactured from the following materials:

- Hot Rolled Steel SheetASTM A-1011 or Cold Rolled Steel SheetASTM A-1008
- Stainless Steel-Type 304/316LASTM A-240
- Aluminum Clamps 5052H32ASTM B-209

FINISH

H-STRUT pipe clamps are available in the following finishes:

- Electro GalvanizedASTM B-633
- Hot Dipped Galvanized.ASTM A-123
- Zinc Trivalent Chromium.ASTM B-633-85
- Powder Coated Supr-Green.ASTM B-117
- Copper Plated.ASTM B-734-84

ORDERING

Please specify catalog number, size and finish.

Project Information			
Project:	Notes:		
Address:			
Contractor:			
Engineer:			
Approval			
<input type="checkbox"/> Approved <input type="checkbox"/> Approved as Noted <input type="checkbox"/> Not Approved	Signature:	Remarks:	