

MACHINE KEYS

HUYETT.COM • 785-392-3017

BOX 232 • MINNEAPOLIS, KS • 67467
SALES@HUYETT.COM • FAX 785-392-2845

WOODRUFF – IMPERIAL

DESCRIPTION

Woodruff keys are commonly found in machine tools and automotive applications. They are designed to be installed deep into a shaft and firmly embedded. As a result, they are less likely to slip out of the key way. Both round and flat bottom designs are standard and function equally. If a specific style is required, please contact our Sales Team.

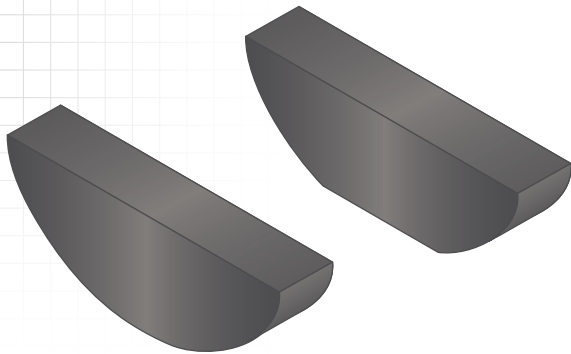

HOW TO IDENTIFY

1. Verify half-moon shape.
2. Measure diameter (B).
3. Measure width (A).
4. Find the part number in the chart on the next page.
Or, compare your part to the part silhouettes in the chart on the next page.

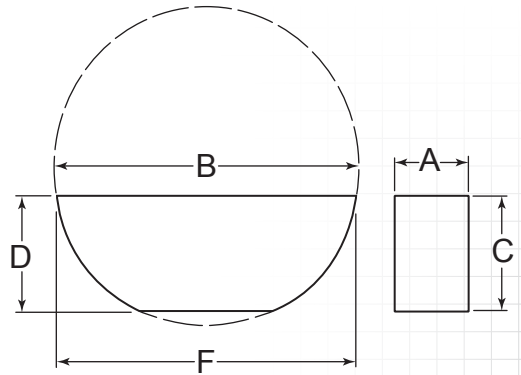

PREFIX MATERIAL/FINISH

WKA = COLD FINISHED ALLOY STEEL, PLAIN*
WKC = COLD FINISHED STEEL, PLAIN*
WKS = 300 SERIES STAINLESS STEEL, PLAIN
WKS-XXX-PAS = 300 SERIES STAINLESS STEEL, PASSIVATED

WKS-XXX-ZC = COLD FINISHED STEEL, ZINC CLEAR TRIVALENT
WKS-XXX-ZY = COLD FINISHED STEEL, ZINC YELLOW TRIVALENT
 Material/finish combinations may not be available in all sizes.

WOODRUFF KEYS CAN BE PRODUCED IN MANY HEIGHT, WIDTH, AND LENGTH COMBINATIONS

WOODRUFF TOLERANCES

MATERIAL		DIAMETER (B)		WIDTH (A)	
(Prefix)	(Material/Finish)	(Size Range)	(Tolerance)	(Size Range)	(Tolerance)
WKA	Cold Finished Alloy Steel, Plain*	All Sizes	+0/-.0100"	All Sizes	+0/-.0010"
WKC	Cold Finished Steel, Plain*				
WKS	300 Series Stainless Steel, Plain				
WKS-XXX-PAS	300 Series Stainless Steel, Passivated				
WKC-XXX-ZC	Cold Finished Steel, Zinc Clear Trivalent				
WKC-XXX-ZY	Cold Finished Steel, Zinc Yellow Trivalent				

ZINC PLATING AND OTHER FINISHES
AVAILABLE FOR ALL PARTS
SEE PAGE 16

WIDTH MEASUREMENTS

.0625" (1/16)	.0937" (3/32)	.1250" (1/8)	.1562" (3/32)	.1875" (3/16)	.2187" (7/32)	.2500" (1/4)	.3125" (5/16)	.3750" (3/8)	.4375" (7/16)	.5000" (1/2)	.6250" (5/8)	.7500" (3/4)	

FOR DETAILED SPECIFICATIONS AND TOLERANCES, VISIT HUYETT.COM.
 Prices, materials, dimensions, tolerances, designs, and grades subject to change without notice. © 2016 G.L. Huyett
 *Limited warranty for surface finish: 30 days from date of shipment. See page 12 for details.

WOODRUFF – IMPERIAL

	1/4"			5/16"			3/8"			1/2"		
ITEM NUMBER	PREFIX-201	PREFIX-206	PREFIX-207	PREFIX-211	PREFIX-212	PREFIX-213	PREFIX-001	PREFIX-002	PREFIX-003			
(B) DIAMETER	.250" (1/4)	.313" (5/16)	.313" (5/16)	.375" (3/8)	.375" (3/8)	.375" (3/8)	.500" (1/2)	.500" (1/2)	.500" (1/2)			
(A) WIDTH	.063" (1/16)	.063" (1/16)	.094" (3/32)	.063" (1/16)	.094" (3/32)	.125" (1/8)	.063" (1/16)	.094" (3/32)	.125" (1/8)			

	5/8"						3/4"		
ITEM NUMBER	PREFIX-004	PREFIX-005	PREFIX-006	PREFIX-061	PREFIX-007	PREFIX-008	PREFIX-009	PREFIX-091	
(B) DIAMETER	.625" (5/8)	.625" (5/8)	.625" (5/8)	.625" (5/8)	.750" (3/4)	.750" (3/4)	.750" (3/4)	.750" (3/4)	
(A) WIDTH	.094" (3/32)	.125" (1/8)	.156" (5/32)	.188" (3/16)	.125" (1/8)	.156" (5/32)	.188" (3/16)	.250" (1/4)	

	7/8"				2-1/8"			
ITEM NUMBER	PREFIX-010	PREFIX-011	PREFIX-012	PREFIX-00A	PREFIX-026	PREFIX-027	PREFIX-028	PREFIX-029
(B) DIAMETER	.875" (7/8)	.875" (7/8)	.875" (7/8)	.875" (7/8)	2.125" (2-1/8)	2.125" (2-1/8)	2.125" (2-1/8)	2.125" (2-1/8)
(A) WIDTH	.156" (5/32)	.188" (3/16)	.219" (7/32)	.250" (1/4)	.188" (3/16)	.250" (1/4)	.313" (5/16)	.375" (3/8)

Images are approximate actual size.

MILLING THE KEY WAY

AN ARBOR CUTTING TOOL IS USED TO CUT A SEMICIRCULAR KEY WAY IN THE SIDE OF THE SHAFT

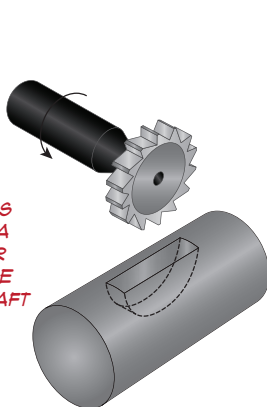

A WOODRUFF OR HI-PRO KEY IS THEN INSERTED TO MATE THE SHAFT TO THE ASSEMBLY

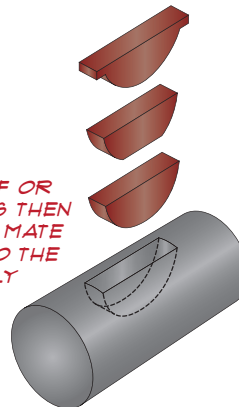

HOW TO READ A PART NUMBER

Woodruff keys come in standard diameter x width combinations.

WKC-001

ITEM
PREFIX

SIZE
CODE

MACHINE KEYS

HUYETT.COM • 785-392-3017

BOX 232 • MINNEAPOLIS, KS • 67467
SALES@HUYETT.COM • FAX 785-392-2845

WOODRUFF – IMPERIAL

PREFIX MATERIAL/FINISH

- WKA** = COLD FINISHED ALLOY STEEL, PLAIN*
 - WKC** = COLD FINISHED STEEL, PLAIN*
 - WKS** = 300 SERIES STAINLESS STEEL, PLAIN
 - WKS-XXX-PAS** = 300 SERIES STAINLESS STEEL, PASSIVATED
 - WKS-XXX-ZC** = COLD FINISHED STEEL, ZINC CLEAR TRIVALENT
 - WKS-XXX-ZY** = COLD FINISHED STEEL, ZINC YELLOW TRIVALENT
- Material/finish combinations may not be available in all sizes.

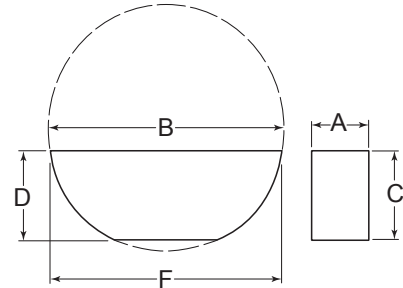

	1"					1-3/8"			
ITEM NUMBER	PREFIX-013	PREFIX-014	PREFIX-015	PREFIX-00B	PREFIX-152	PREFIX-141	PREFIX-022	PREFIX-023	PREFIX-00F
(B) DIAMETER	1.000" (1)	1.000" (1)	1.000" (1)	1.000" (1)	1.000" (1)	1.000" (1)	1.375" (1-3/8)	1.375" (1-3/8)	1.375" (1-3/8)
(A) WIDTH	.188" (3/16)	.219" (7/32)	.250" (1/4)	.313" (5/16)	.375" (3/8)	.250" (1/4)	.250" (1/4)	.313" (5/16)	.375" (3/8)

	1-1/8"				1-1/4"				
ITEM NUMBER	PREFIX-016	PREFIX-017	PREFIX-018	PREFIX-00C	PREFIX-019	PREFIX-020	PREFIX-021	PREFIX-00D	PREFIX-00E
(B) DIAMETER	1.125" (1-1/8)	1.125" (1-1/8)	1.125" (1-1/8)	1.125" (1-1/8)	1.250" (1-1/4)	1.250" (1-1/4)	1.250" (1-1/4)	1.250" (1-1/4)	1.250" (1-1/4)
(A) WIDTH	.188" (3/16)	.219" (7/32)	.250" (1/4)	.313" (5/16)	.188" (3/16)	.219" (7/32)	.250" (1/4)	.313" (5/16)	.375" (3/8)

	1-1/2"			2-1/8"			
ITEM NUMBER	PREFIX-024	PREFIX-025	PREFIX-00G	PREFIX-126	PREFIX-127	PREFIX-128	PREFIX-129
(B) DIAMETER	1.500" (1-1/2)	1.500" (1-1/2)	1.500" (1-1/2)	2.125" (2-1/8)	2.125" (2-1/8)	2.125" (2-1/8)	2.125" (2-1/8)
(A) WIDTH	.250" (1/4)	.313" (5/16)	.375" (3/8)	.188" (3/16)	.250" (1/4)	.313" (5/16)	.375" (3/8)

Images are approximate actual size.

ZINC PLATING AND OTHER FINISHES AVAILABLE FOR ALL PARTS
SEE PAGE 16

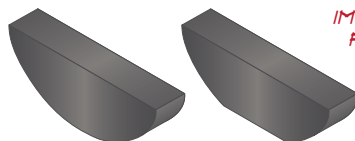

IMPERIAL WOODRUFF KEYS MAY HAVE A ROUNDED OR FLAT BOTTOM AT THE MANUFACTURERS' DISCRETION

BOTH DESIGNS ARE STANDARD

IF A SPECIFIC STYLE IS REQUIRED, PLEASE CONTACT OUR SALES TEAM

FOR DETAILED SPECIFICATIONS AND TOLERANCES, VISIT HUYETT.COM.
Prices, materials, dimensions, tolerances, designs, and grades subject to change without notice. © 2016 G.L. Huyett
*Limited warranty for surface finish: 30 days from date of shipment. See page 12 for details.

WOODRUFF – IMPERIAL

2-3/4"					
ITEM NUMBER	PREFIX-00R	PREFIX-00S	PREFIX-00T	PREFIX-00U	PREFIX-00V
(B) DIAMETER	2.750" (2-3/4)	2.750" (2-3/4)	2.750" (2-3/4)	2.750" (2-3/4)	2.750" (2-3/4)
(A) WIDTH	.250" (1/4)	.313" (5/16)	.375" (3/8)	.438" (7/16)	.500" (1/2)

2-3/4"					
ITEM NUMBER	PREFIX-0RX	PREFIX-0SX	PREFIX-0TX	PREFIX-0UX	PREFIX-0VX
(B) DIAMETER	2.750" (2-3/4)	2.750" (2-3/4)	2.750" (2-3/4)	2.750" (2-3/4)	2.750" (2-3/4)
(A) WIDTH	.250" (1/4)	.313" (5/16)	.375" (3/8)	.438" (7/16)	.500" (1/2)

3-1/2"		
ITEM NUMBER	WKC-030	WKC-032
(B) DIAMETER	3.500" (3-1/2)	3.500" (3-1/2)
(A) WIDTH	.375" (3/8)	.500" (1/2)

3-1/2"		
ITEM NUMBER	PREFIX-034	PREFIX-036
(B) DIAMETER	3.500" (3-1/2)	3.500" (3-1/2)
(A) WIDTH	.625" (5/8)	.750" (3/4)

Images are approximate actual size.

MANUFACTURING CAPABILITIES:

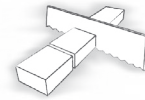

Sawing

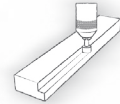

Milling

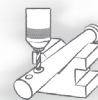

Drilling

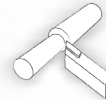

Turning



Tumbling



Centerless Grinding

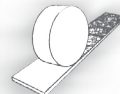

Surface Grinding

FOR MORE INFORMATION ABOUT OUR MANUFACTURING CAPABILITIES SEE "MANUFACTURING PROCESSES" ON PAGE 20



Our *Engineering Handbook* is a great companion resource to this Key Stock Catalog. To learn about the steelmaking process, different grades of steel, platings, finishes, testing hardness, heat treating, and mechanical properties of steel, visit huyett.com/catalogs to view a pdf or download a copy today.