

CHAPTER A

- Step #1: Establish bore diameter
 Step #2: Find Depth of Cut (DOC) requirements
 Step #3: Follow column and row to find correct tool type
 Step #4: Look up tool type to find available widths

		DOC (Depth of cut) t_{max}													
Bore Ø	.039 (1.0)	.059 (1.5)	.091 (2.3)	.098 (2.5)	.126 (3.2)	.138 (3.5)	.169 (4.3)	.177 (4.5)	.256 (6.5)	.315 (8.0)	.327 (8.3)	.366 (9.3)	.394 (10)	.402 (10.2)	.472 (12)
.394 (10.0)	108 306	306													
.472 (12.0)	306 606	306 606	306 606	306 606											
.539 (13.7)	111	111	111												
.630 (16.0)	*116 308 608	*116 308 608	*116 308 608	*116 308 608	*116 308 608	*116 308 608	*116 308 608								
.709 (18.0)	311 611	311 611	311 611	311 611	311 611	311 611									
.819 (20.8)	116	116	116	116	116	116	116								
.866 (22.0)	313 313.D 613 713	313 313.D 613 713	313 313.D 613 713	313 313.D 613 713	313 313.D 613 713	313 313.D 613 713	313 313.D 613 713	313 313.D 613 713							
1.102 (28.0)	328 628	328 628	328 628	328 628	328 628	328 628	328 628	328 628	328 628	*328 *628	*328 *628	*328 *628			
1.260 (32)	332 632	332 632	332 632	332 632	332 632	332 632	332 632	332 632	332 632	332 632	332 632	*332 *632	*332 *632		
1.378 (35)	335	335	335	335	335	335	335	335	335	335					
1.417 (36)	636	636	636	636	636	636	636	636	636	636	636	636	636	636	*636

		Tool Type											
	108	306	606	111	308	608	311	611	116	313	313.D	613	713
Max. width as Standard	.079 (2.0)	.098 (2.5)	.098 (2.5)	.125 (3.2)	.125 (3.2)	.098 (2.5)	.125 (3.2)	.118 (3.0)	.157 (4.0)	.250 (6.3)	.128 (3.25)	.157 (4.0)	.118 (3.0)
Max. width as Special	.126 (3.2)	.157 (4.0)	.126 (3.2)	.173 (4.4)	.165 (4.2)	.185 (4.7)	.315 (8.0)	.236 (6.0)	.231 (5.4)	.354 (9.0)	.130 (3.3)	.283 (7.2)	.150 (3.8)
Page number	A9	A12	A21	A31	A34	A39	A49	A54	A60	A71	A87	A82	A84

		Tool Type (continued)					
	328	628	332	632	636	335	
Max. width as Standard	.157 (4.0)	.157 (4.0)	.157 (4.0)	.157 (4.0)	.118 (3.0)	.236 (6.0)	
Max. width as Special	.398 (10.1)	.303 (7.7)	.398 (10.1)	.299 (5.8)	.228 (5.8)	.598 (15.2)	
Page number	A101	A105	A117	A117	A122	A129	

*116 - With oriented spindle stopped offset of center line (single flute effective, see page A57).

*328 - Requires holder for increased milling depth from page A95.

*332 / 632 / 636 - Requires holder for increased milling depth from pages A112-A113.

Dimensions in inch (mm)

MILLING SHANK type **MU / M306**

from bore \varnothing .394" (10.0 mm)



MILLING SHANK Type

MU306

with through coolant supply

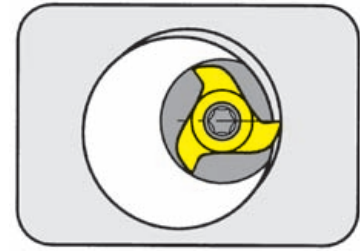
Cutting edge \varnothing

Ds .378 - .461"

Material of shank: Carbide - Giving a good vibration resistance

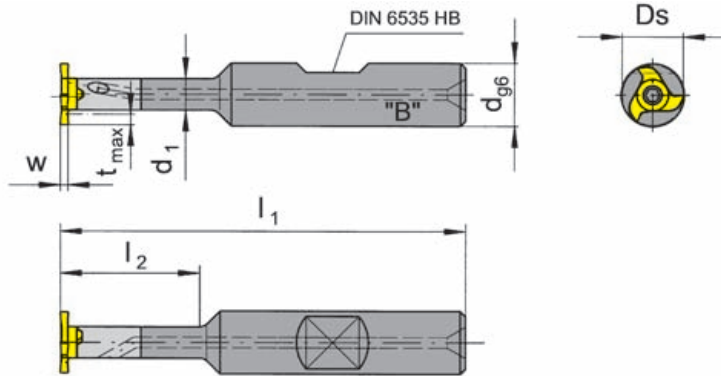

for use with Insert

Type U108
U306
108
306
606

Picture = right hand cutting version

Part number	l_1	l_2	d_1	d
MU306.0500.01B	3.150	.827		
MU306.0500.02B	3.543	1.181	.236	.500
MU306.0500.03B	3.937	1.654		
MU306.0625.01B	3.937	.984	.287	.625

Further sizes upon request

w, Ds, t_{max} see inserts

Dimensions in inch

Ordering note:All milling cutter shanks can be used for **right** and **left** hand inserts type 108.

Milling cutter shanks with damaged seating can be repaired by HORN.

For torque specifications of the screw, please see Technical Instructions.

Spare parts

Milling shank	Screw	TORX PLUS® Wrench
MU306.0...	2.6.5T8EP	T8PL

MILLING SHANK Type

M306

with through coolant supply

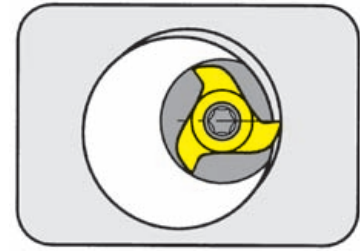

Cutting edge \varnothing

Ds 9.6/11.7 mm

Material of shank: Carbide - Giving a good vibration resistance

for use with Insert

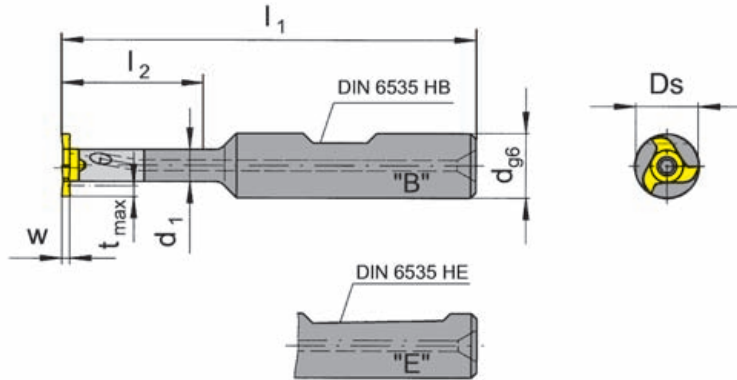

Type U108
U306
108
306
606

Picture = right hand cutting version

Part number	l_1	l_2	d_1	d	Form
M306.0012.01B	80	21	6	12	B
M306.0012.02B	90	30			
M306.0012.03B	100	42			
M306.0012.01E	80	21	6	12	E
M306.0012.02E	90	30			
M306.0012.03E	100	42			

Further sizes upon request

w, Ds, t_{max} see inserts

Dimensions in mm

Ordering note:

All milling cutter shanks can be used for **right** and **left** hand inserts type 108.

Milling cutter shanks with damaged seating can be repaired by HORN.

For torque specifications of the screw, please see Technical Instructions.

Spare parts

Milling shank	Screw	TORX PLUS® Wrench
M306.0012.0...	2.6.5T8EP	T8PL

MILLING SHANK Type

M306

with through coolant supply

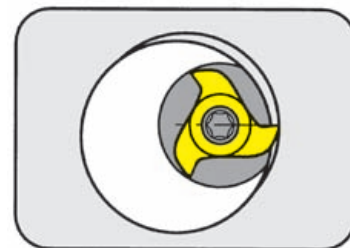
Cutting edge \emptyset

Ds 9.6/11.7 mm

Material of shank: Carbide - Giving a good vibration resistance

for use with Insert

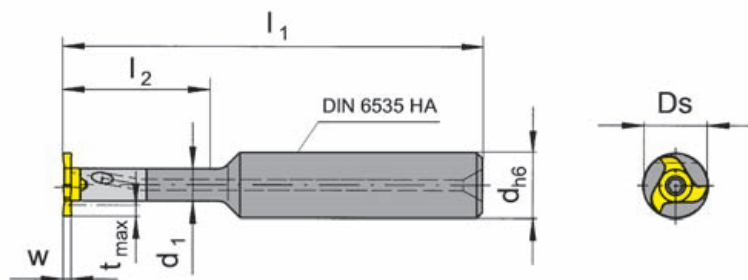
 Type U108
 U306
 108
 306
 606

Picture = right hand cutting version

Part number	l_1	l_2	d_1	d
M306.0012.01A	80	21	6	12
M306.0012.02A	90	30		
M306.0012.03A	100	42		

Further sizes upon request

w, Ds, t_{max} see inserts

Dimensions in mm

Ordering note:

Milling cutter shanks with damaged seating can be repaired by HORN.

All milling cutter shanks can be used for **right** and **left** hand inserts type 108.

For torque specifications of the screw, please see Technical Instructions.

Spare parts

Milling shank	Screw	TORX PLUS® Wrench
M306.0012.0...	2.6.5T8EP	T8PL

MILLING SHANK Type

M306.ST

no coolant supply

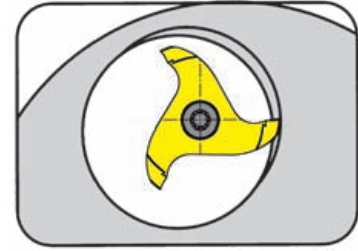

Cylindrical steel milling shank for collets Ds 9.6 / 11.7 mm

with cylindrical shank for CNC-lathes

for use with Insert

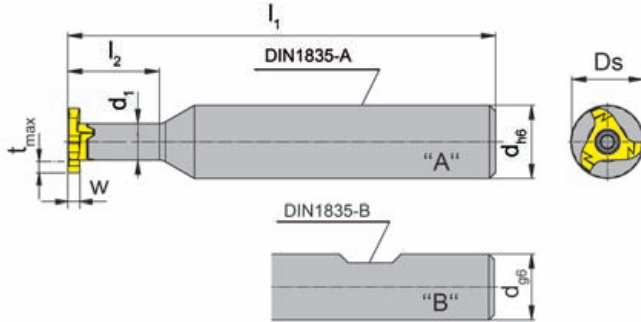

- Type
- U108
 - U306
 - 108
 - 306
 - 606

Picture = right hand cutting version

Part number	l_1	l_2	d_1	d	Form
M306.ST10.01A	60	15	6	10	A
M306.ST12.01A	70	15	6	12	A
M306.ST10.01B	60	15	6	10	B
M306.ST12.01B	70	15	6	12	B

Further sizes upon request

w, Ds, t_{max} see inserts

Dimensions in mm

Ordering note:

All milling cutter shanks can be used for **right** and **left** hand inserts type 108.

For torque specifications of the screw, please see Technical Instructions.

Spare parts

Milling shank	Screw	TORX PLUS® Wrench
M306.ST1...	2.6.5T8EP	T8PL

SCREW-IN CUTTER Type

M306.M

no coolant supply

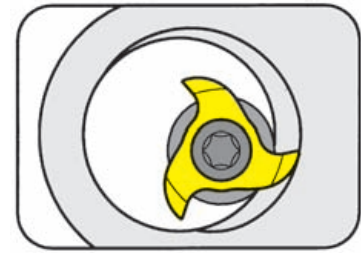

Screw-in Cutter for basic holder type WFB.20

for use with Insert

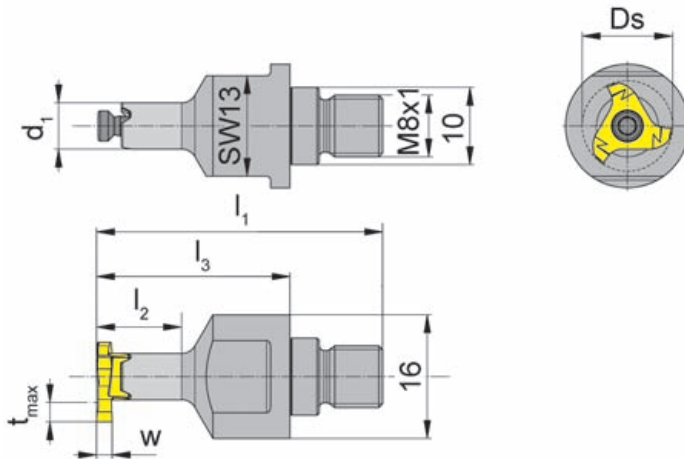
 Type U108
 U306
 108
 306
 606

Picture = right hand cutting version

Part number	l_1	l_2	l_3	d_1
M306.M081.01	37	11	25	6

Further sizes upon request

w, Ds, t_{max} see inserts

Dimensions in mm

All milling cutter shanks can be used for **right** and **left** hand inserts type 108.

For torque specifications of the screw, please see Technical Instructions.



Spare parts

Screw-in cutter	Screw	TORX PLUS® Wrench
M306.M081.01	2.6.5T8EP	T8PL

BASIC HOLDER Type

WFB

Basic holder WFB.20 for screw-in cutter

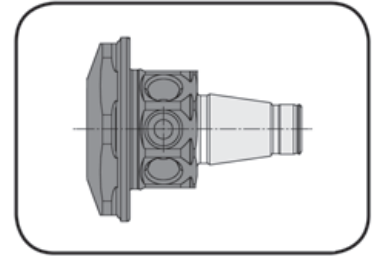

for use with Screw-in cutter

- Type
- M306.M081...
 - M308.M081...
 - M311.M081...
 - M313.M081...
 - M328.M081...
 - M332.M081...

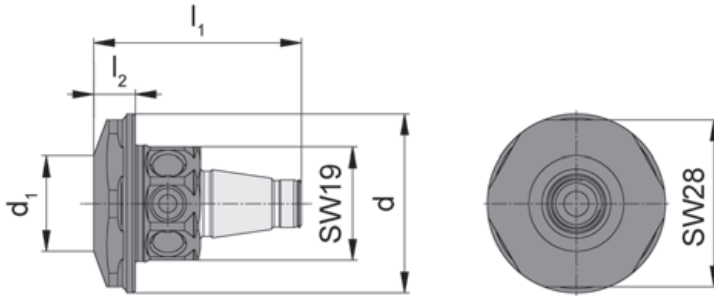

Part number	l_1	l_2	d_1	d
WFB.2012.M081.01	35	7	16	30

Further sizes upon request

Dimensions in mm



MILLING SHANK Type

M306.ER

no coolant supply

Milling shanks for collet chucks DIN6499-A (8°) Ds 9.6 / 11.7 mm

with ER taper for CNC-lathes

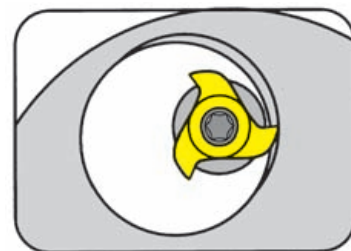

for use with Insert

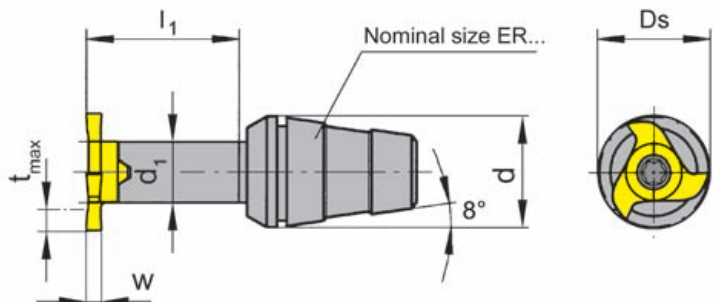
 Type U108
 U306
 108
 306
 606

Picture = right hand cutting version

Part number	l_1	d_1	d	Clamping nut
M306.ER11.02	16	6	11	ER11.6499

Further sizes upon request

w, Ds, t_{max} see inserts

Dimensions in mm

Ordering note:All milling cutter shanks can be used for **right** and **left** hand inserts type 108.

For torque specifications of the screw, please see Technical Instructions.

Clamping nut is not combined with milling shank - separate order required!

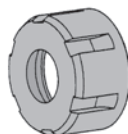
**Spare parts**

Milling shank	Screw	TORX PLUS® Wrench
M306.ER11.02	2.6.5T8EP	T8PL

INSERT Type

108/U108

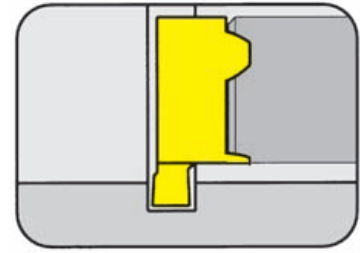

Depth of groove up to	.039"
Width of circlip Nw	.028 - .063"
Cutting edge Ø	Ds .378"

Widths for circlip grooves DIN 471/472

for use with Milling shank

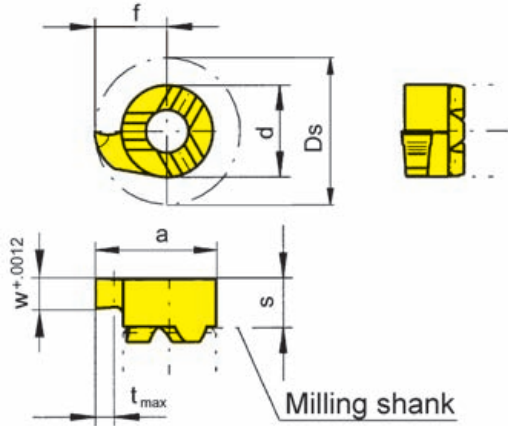

- Type
- MU306
 - M306
 - M306.ST
 - M306.ER
 - M306.M

R = right hand version shown

L = left hand version

Part number	Nw	w	s	f	a	d	t _{max}	Ds	Carbide grades			
									MG12	TN35	T125	TH35
R/LU108.0031.00	-	.031	.142	.189	.307	.236	.039	.378	Δ	▲/▲		
R/LU108.0039.00		.039							▲			
R/L108.0070.00	.028	.029	.142	.189	.307	.236	.039	.378		▲/▲		▲/▲
R/L108.0080.00	.031	.033							▲/▲	▲/▲		
R/L108.0090.00	.035	.037							▲/▲	▲/▲		
R/L108.0110.00	.043	.047	.126	.189	.307	.236	.039	.378	▲/▲	▲/▲		▲/▲
R/L108.0130.00	.051	.055							▲/▲	▲/▲	▲/▲	
R/L108.0160.00	.063	.067							▲/▲	▲/▲	▲/▲	

- ▲ on stock Δ 4 weeks
- main recommendation
- alternative recommendation
- uncoated grades
- coated grades
- brazed/Cermet

P	○	●	●	●
M	●	●	●	●
K	●	●	●	●
N	●	●	●	●
S	●	●	●	●
H				

Dimensions in inch

Carbide grades

State R or L version

Note:

Inserts with width of groove w .029" - .039" are NOT face cutting!

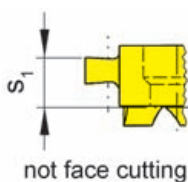

INSERT Type

108/U108

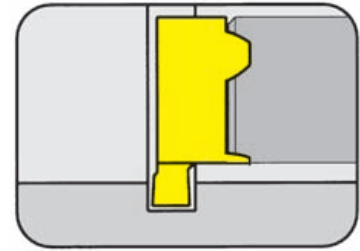

Depth of groove up to .039"
 Width of groove up to .079"
 Cutting edge \emptyset Ds .378"

for use with Milling shank

Type MU306
 M306
 M306.ST
 M306.ER
 M306.M

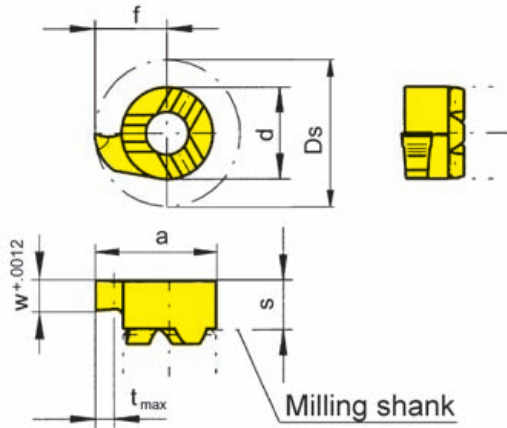

R = right hand version shown

L = left hand version

Part number	w	s	f	a	d	t _{max}	Ds	MG12	TN35	T125	TH35
R/L108.0150.00	.059							▲/▲	▲/▲		▲/▲
R/L108.0200.00	.079	.126	.189	.307	.236	.039	.378	▲/▲	▲/▲		▲/▲
R/LU108.0046.00	.046							▲/	▲/		
R/LU108.0056.00	.056								▲/▲		
R/LU108.0062.00	.062	.126	.189	.307	.236	.039	.378	▲/	▲/▲		
R/LU108.0078.00	.078								▲/▲		
								P	o	•	•
								M	•	•	•
								K	•	•	•
								N	•	•	•
								S	•	•	•
								H			

▲ on stock Δ 4 weeks
 • main recommendation
 o alternative recommendation
 □ uncoated grades
 ■ coated grades
 ■ brazed/Cermet

Carbide grades

Dimensions in inch
 State R or L version

INSERT Type

108/U108

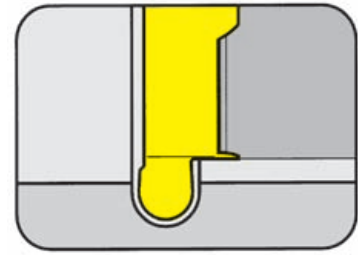

Depth of groove up to .039"
 Full radius r .015 - .039"
 Cutting edge \emptyset Ds .378"

for use with Milling shank

Type MU306
 M306
 M306.ST
 M306.ER
 M306.M

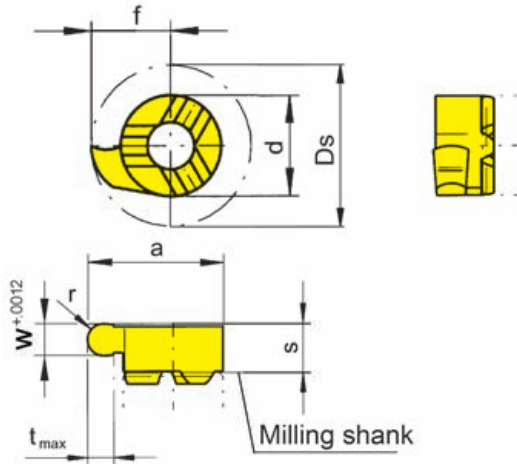

R = right hand version shown

L = left hand version

Full radius

Part number	w	r	s	f	a	d	t _{max}	Ds	Carbide grades				
									MG12	TN35	T125	TF45	TH35
R/L108.0004.08	.031	.016							▲/Δ	▲/▲			▲/▲
R/L108.0006.12	.047	.024	.126	.189	.307	.236	.039	.378	▲/▲	▲/▲			▲/▲
R/L108.0009.18	.071	.035							▲/▲	▲/▲	▲/Δ		▲/▲
R/LU108.0015.31	.031	.015								▲/▲	Δ/		
R/LU108.0023.46	.046	.023								▲/▲			
R/LU108.0031.62	.062	.031	.126	.189	.307	.236	.039	.378	▲/	▲/▲			▲/
R/LU108.0039.78	.078	.039								▲/▲			▲/

- ▲ on stock Δ 4 weeks
- main recommendation
- alternative recommendation
- uncoated grades
- coated grades
- brazed/Cermet

Dimensions in inch

State R or L version

	P	M	K	N	S	H
MG12	○	●	●	●	●	●
TN35	●	●	●	●	●	●
T125	●	●	●	●	●	●
TF45	●	●	●	●	●	●
TH35	●	●	●	●	●	●

Carbide grades

INSERT Type

306

Depth of groove up to	.045"
Width of circlip Nw	.020 - .028"
Cutting edge Ø	Ds .382"

Widths for circlip grooves DIN 471/472

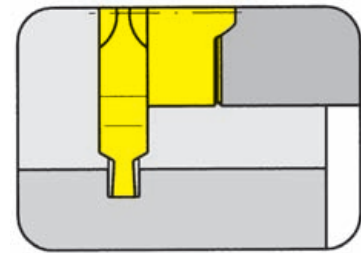

for use with Milling shank

- Type
- MU306
 - M306
 - M306.ST
 - M306.ER
 - M306.M

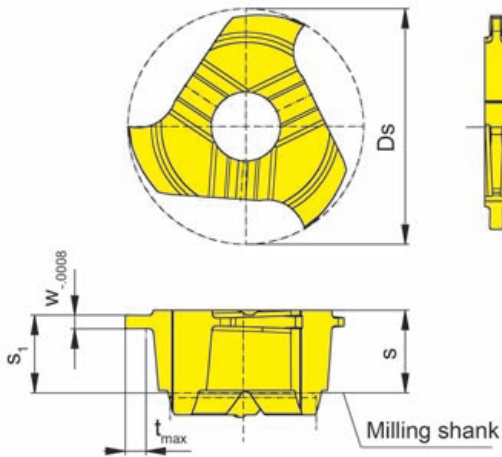

Picture = right hand cutting version

not face cutting,
limited depth of cut

Part number	Nw	w	s ₁	s	t _{max}	Ds	Carbide grades			
							MG12	TN35	TA45	AS45
306.0050.10.00	.020	.022	.126	.134	.033	.382			▲	
306.0070.10.00	.028	.030	.126	.134	.045	.382			▲	
							P		•	
							M		•	
							K		•	
							N		•	
							S		•	
							H			

- ▲ on stock Δ 4 weeks
- main recommendation
- o alternative recommendation
- uncoated grades
- coated grades
- brazed/Cermet

Dimensions in inch

INSERT Type

306

Depth of groove up to	.059"
Width of circlip Nw	.031 - .063"
Cutting edge Ø	Ds .382"

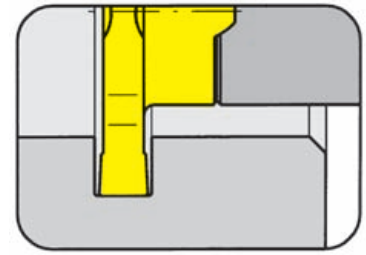

Widths for circlip grooves DIN 471/472

for use with Milling shank

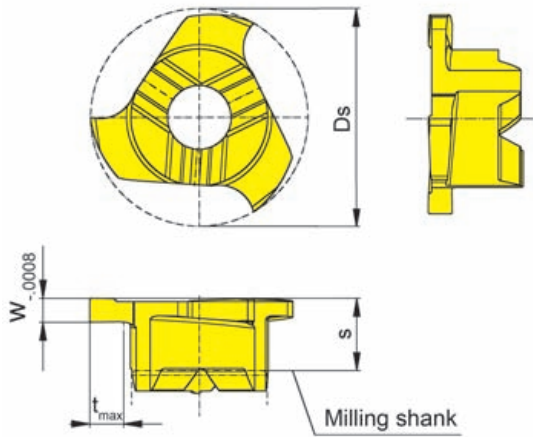

- Type
- MU306
 - M306
 - M306.ST
 - M306.ER
 - M306.M

Picture = right hand cutting version

Part number	Nw	w	s	t _{max}	Ds	Carbide grades			
						MG12	TN35	TA45	AS45
306.0080.10.00	.031	.034						▲	
306.0090.10.00	.035	.038						▲	
306.0100.10.00	.039	.042						▲	
306.0110.10.00	.043	.048	.126	.059	.382			▲	
306.0130.10.00	.051	.056						▲	▲
306.0160.10.00	.063	.067						▲	▲
<ul style="list-style-type: none"> ▲ on stock Δ 4 weeks ● main recommendation ○ alternative recommendation □ uncoated grades ■ coated grades ■ brazed/Cermet 						P		●	●
						M		●	●
						K		●	●
						N		●	○
						S		●	●
						H			

Dimensions in inch

Carbide grades

INSERT Type

306

Depth of groove up to .059"
 Width of groove up to .079"
 Cutting edge \emptyset Ds .382"

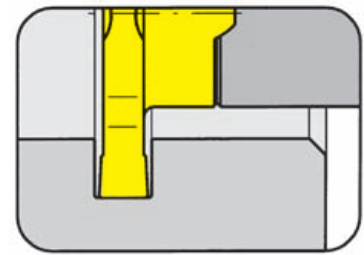

for use with Milling shank

- Type MU306
 M306
 M306.ST
 M306.ER
 M306.M

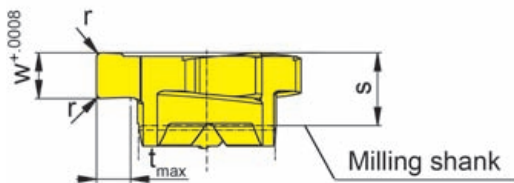
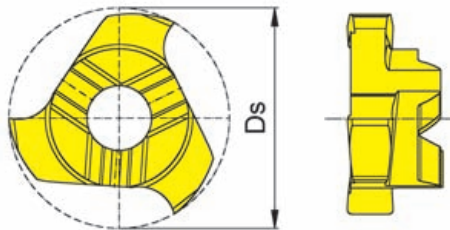

Picture = right hand cutting version

Part number	w	r	s	t _{max}	Ds	Carbide grades			
						MG12	TN35	TA45	AS45
306.0150.10.00	.059	-	.126	.059	.382			▲	▲
306.0200.10.00	.079	.008	.126	.059	.382			▲	▲
						P		•	•
						M		•	•
						K		•	•
						N		•	○
						S		•	•
						H			

- ▲ on stock Δ 4 weeks
- main recommendation
- alternative recommendation
- uncoated grades
- coated grades
- brazed/Cermet

Dimensions in inch

Carbide grades

INSERT Type

306

Depth of groove up to	.098"
Width of groove	.039"
Cutting edge \emptyset	Ds .461"

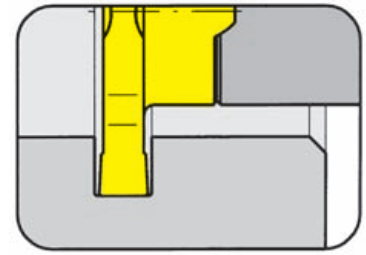

for use with Milling shank

- Type
- MU306
 - M306
 - M306.ST
 - M306.ER
 - M306.M

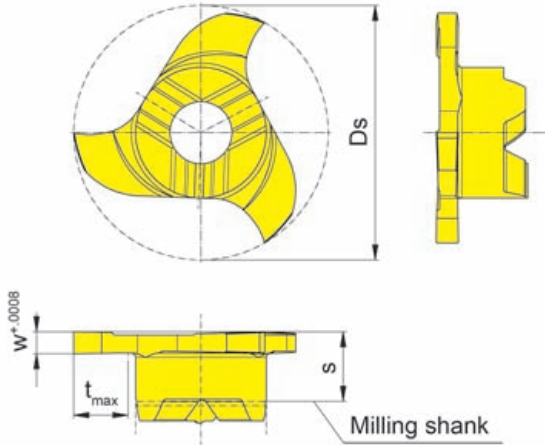

Picture = right hand cutting version

Part number	w	s	t _{max}	Ds	Carbide grades		
					MG12	TN35	AS45
306.0100.1.00	.039	.126	.098	.461		▲	
▲ on stock Δ 4 weeks					P	•	
● main recommendation					M	•	
○ alternative recommendation					K	•	
■ uncoated grades					N	•	
■ coated grades					S	•	
■ brazed/Cermet					H		

Dimensions in inch

INSERT Type

306

Depth of groove up to	.098"
Width of circlip Nw	.043 - .063"
Cutting edge Ø	Ds .461"

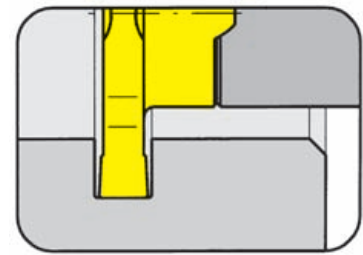

Widths for circlip grooves DIN 471/472

for use with Milling shank

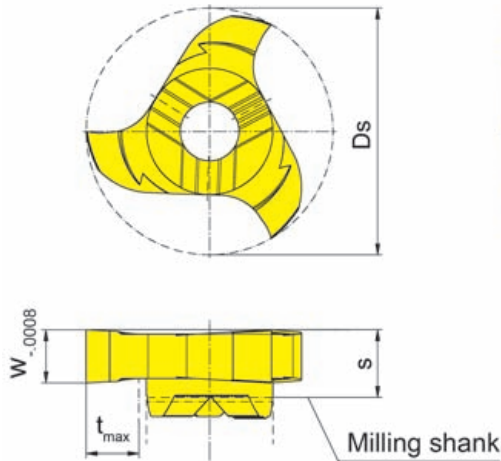

- Type
- MU306
 - M306
 - M306.ST
 - M306.ER
 - M306.M

Picture = right hand cutting version

Part number	Nw	w	s	t _{max}	Ds	Carbide grades			
						MG12	TN35	AS45	TF45
306.0110.00	.043	.048				▲	▲		▲
306.0130.00	.051	.056	.126	.098	.461		▲		
306.0160.00	.063	.067					▲		
						P	o	•	•
						M	•	•	•
						K	•	•	•
						N	•	•	•
						S	•	•	•
						H			

- ▲ on stock Δ 4 weeks
- main recommendation
- o alternative recommendation
- uncoated grades
- coated grades
- brazed/Cermet

Dimensions in inch

Carbide grades

INSERT Type

306/U306

Depth of groove up to .098"
 Width of groove up to .118"
 Cutting edge Ø Ds .461"

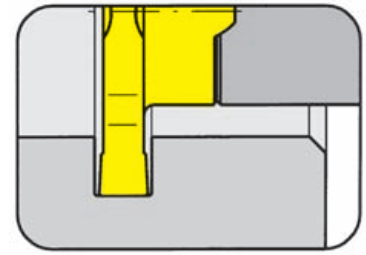

for use with Milling shank

Type MU306
 M306
 M306.ST
 M306.ER
 M306.M

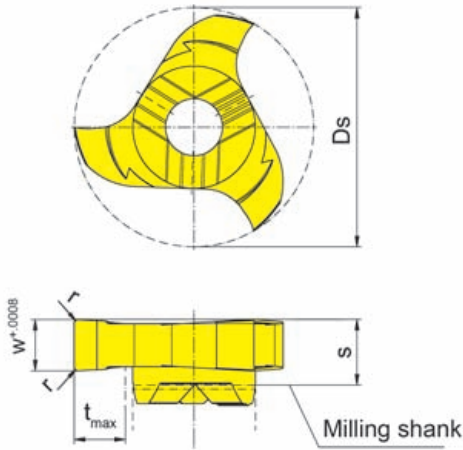

Picture = right hand cutting version

Part number	w	r	s	t _{max}	Ds	Carbide grades			
						MG12	TN35	AS45	TF45
306.0150.00	.059	-				▲	▲	▲	▲
306.0200.00	.079	.008				▲	▲	▲	▲
306.0250.00	.098	.008	.126	.098	.461	▲	▲	▲	▲
306.0300.00	.118	.008					▲		
U306.0046.00	.046					▲	▲		▲
U306.0056.00	.056						▲		
U306.0062.00	.062	-	.126	.098	.461		▲		
U306.0078.00	.078						▲		
U306.0094.00	.094						▲		△
U306.0046.08	.046						▲		▲
U306.0062.08	.062						▲		▲
U306.0078.08	.078	.008	.126	.098	.461		▲		▲
U306.0094.08	.094						▲		△

▲ on stock △ 4 weeks
 ● main recommendation
 ○ alternative recommendation
 ■ uncoated grades
 ■ coated grades
 ■ brazed/Cermet

Dimensions in inch

Carbide grades

INSERT Type

306

machining of aluminium

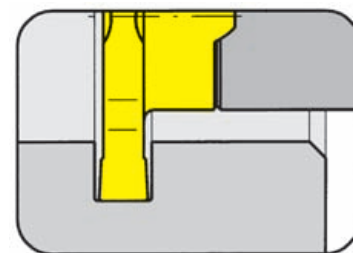

Depth of groove up to	.098"
Width of circlip Nw	.043 - .063"
Cutting edge Ø	Ds .461"

Widths for circlip grooves DIN 471/472

for use with Milling shank

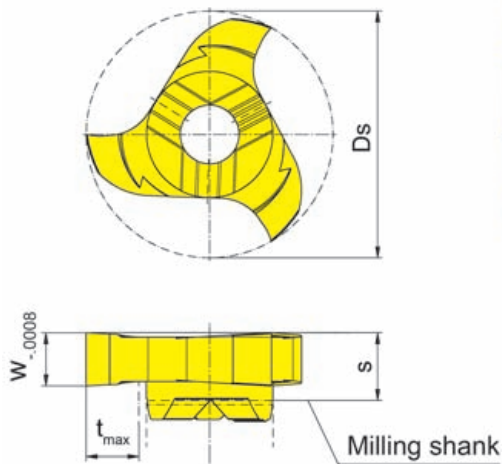

- Type
- MU306
 - M306
 - M306.ST
 - M306.ER
 - M306.M

Picture = right hand cutting version

Part number	Nw	w	s	t _{max}	Ds	Carbide grades	
						MG12	TI25
306.0110.40	.043	.048					▲
306.0130.40	.051	.056	.126	.098	.461		▲
306.0160.40	.063	.067					▲
						P	•
						M	•
						K	•
						N	•
						S	•
						H	•

Dimensions in inch

Carbide grades

- ▲ on stock Δ 4 weeks
- main recommendation
- o alternative recommendation
- uncoated grades
- coated grades
- brazed/Cermet

INSERT Type

306

machining of aluminium

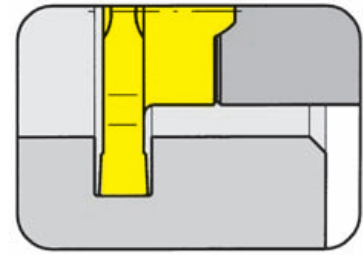

Depth of groove up to	.098"
Width of groove up to	.098"
Cutting edge Ø	Ds .461"

for use with Milling shank

- Type
- MU306
 - M306
 - M306.ST
 - M306.ER
 - M306.M

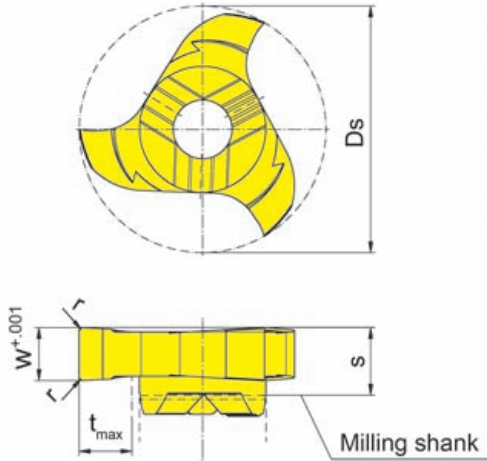

Picture = right hand cutting version

Part number	w	r	s	t _{max}	Ds	Carbide grades	
						MG12	TI25
306.0150.40	.059	-				▲	▲
306.0200.40	.079	.008	.126	.098	.461	▲	▲
306.0250.40	.098	.008				▲	▲
						P	•
						M	•
						K	•
						N	•
						S	•
						H	•

- ▲ on stock Δ 4 weeks
- main recommendation
- alternative recommendation
- uncoated grades
- coated grades
- brazed/Cermet

Dimensions in inch

Carbide grades

INSERT Type

306/U306

Depth of groove up to	.098"
Full radius	r .031 - .047"
Cutting edge Ø	Ds .461"

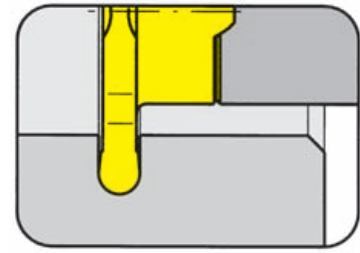

for use with Milling shank

- Type MU306
M306
M306.ST
M306.ER
M306.M

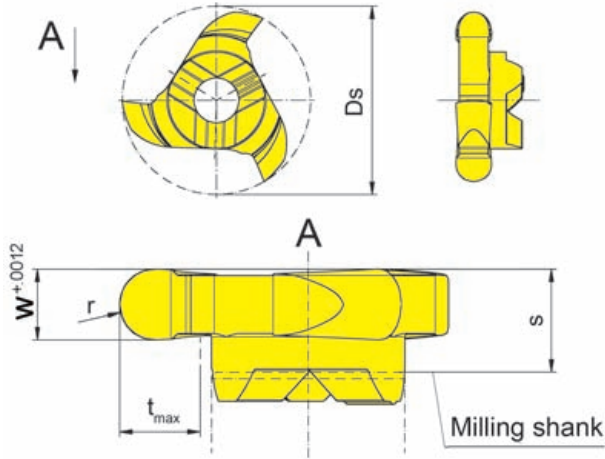

Picture = right hand cutting version

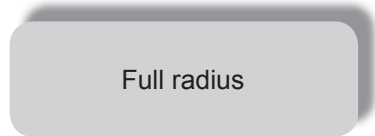

Part number	w	r	s	t _{max}	Ds	Carbide grades				
						MG12	TN35	TI25	AS45	TF45
306.0011.22	.087	.043	.126	.098	.461		▲	▲	▲	
U306.0031.62	.062	.031	.126	.098	.461		▲			▲
U306.0047.94	.094	.047	.126	.098	.461		▲			▲
						P	•	•	•	•
						M	•	•	•	•
						K	•	•	•	•
						N	•	•	○	•
						S	•	•	•	•
						H				

- ▲ on stock Δ 4 weeks
- main recommendation
- alternative recommendation
- uncoated grades
- coated grades
- brazed/Cermet

Dimensions in inch

Carbide grades

INSERT Type

606

Depth of groove up to	.098"
Width of circlip Nw	.043 - .063"
Cutting edge Ø	Ds .461"

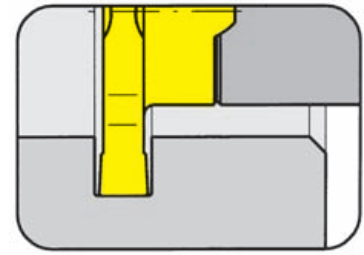

Widths for circlip grooves DIN 471/472

for use with Milling shank

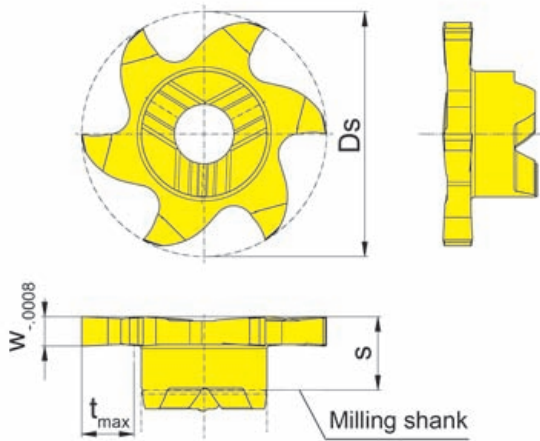

- Type
- MU306
 - M306
 - M306.ST
 - M306.ER
 - M306.M

Picture = right hand cutting version

Part number	Nw	w	s	t _{max}	Ds	Carbide grades			
						MG12	TN35	TA45	AS45
606.0110.00	.043	.048					▲		
606.0130.00	.051	.056	.138	.098	.461			▲	
606.0160.00	.063	.067						▲	▲
						P		•	•
						M		•	•
						K		•	•
						N		•	○
						S		•	•
						H			

- ▲ on stock Δ 4 weeks
- main recommendation
- alternative recommendation
- uncoated grades
- coated grades
- brazed/Cermet

Dimensions in inch

Carbide grades

INSERT Type

606

Depth of groove up to .098"
 Width of groove up to .098"
 Cutting edge \emptyset Ds .461"

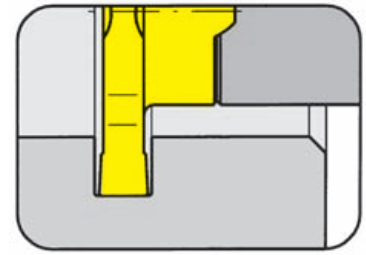

for use with Milling shank

Type MU306
 M306
 M306.ST
 M306.ER
 M306.M

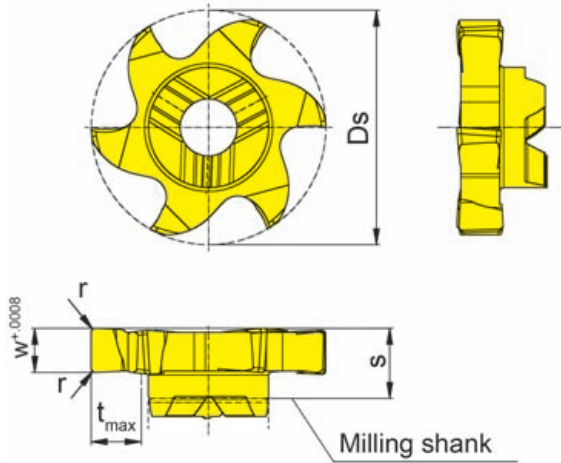

Picture = right hand cutting version

Part number	w	r	s	t _{max}	Ds	Carbide grades			
						MG12	TN35	TA45	AS45
606.0150.00	.059	-	.126					▲	▲
606.0200.00	.079	.008	.138	.098	.461			▲	▲
606.0250.00	.098	.008	.138					▲	▲
						P		●	●
						M		●	●
						K		●	●
						N		●	○
						S		●	●
						H			

- ▲ on stock Δ 4 weeks
- main recommendation
- alternative recommendation
- uncoated grades
- coated grades
- brazed/Cermet

Dimensions in inch

Carbide grades

MILLING SHANK type **MU / M308**
from bore \varnothing .539" (13.7 mm)

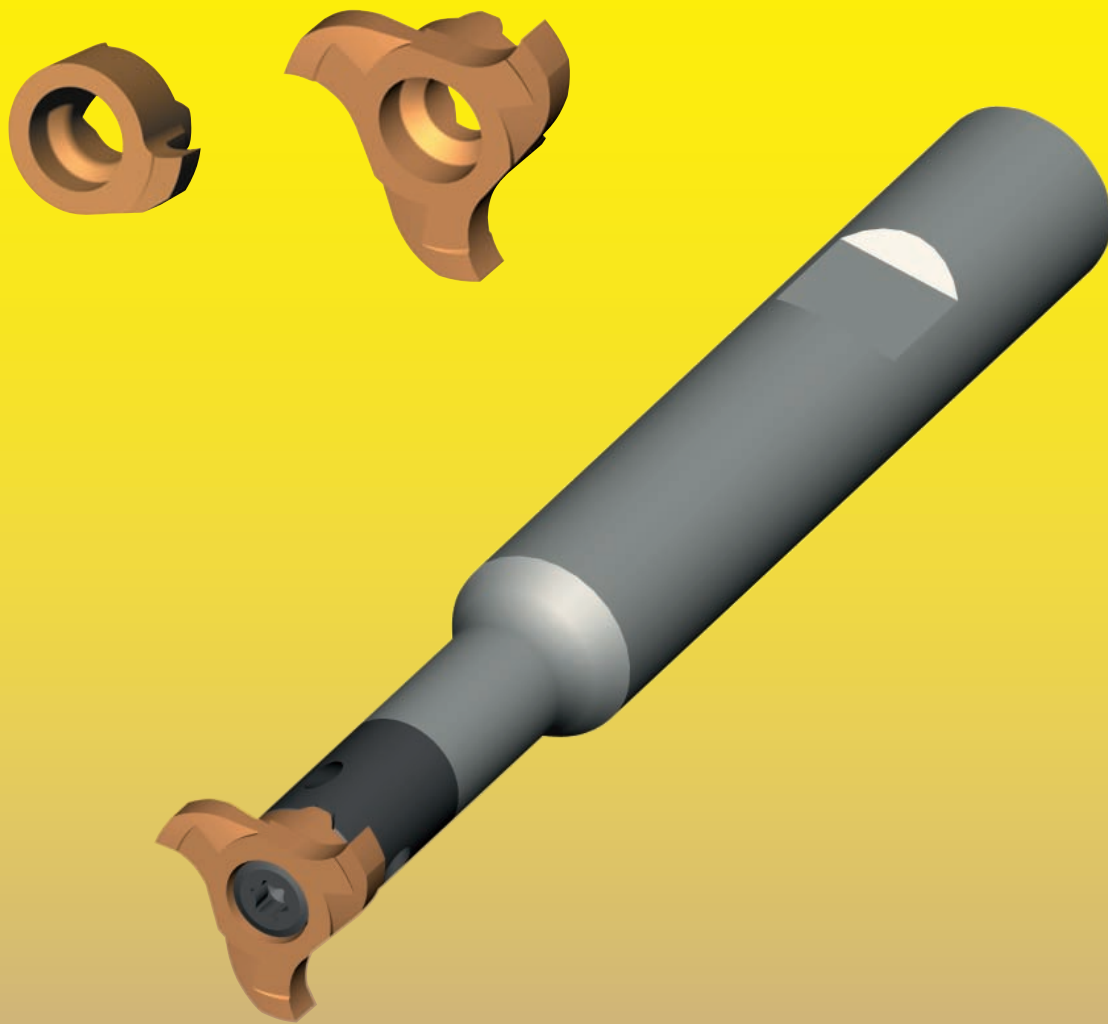

MILLING SHANK Type

MU308

with through coolant supply

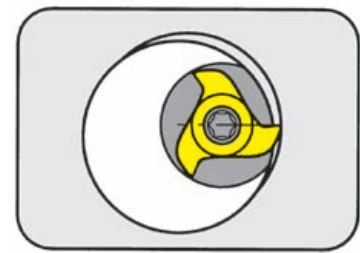
Cutting edge \emptyset

Ds .528 - .618"

Material of shank: Carbide - Giving a good vibration resistance

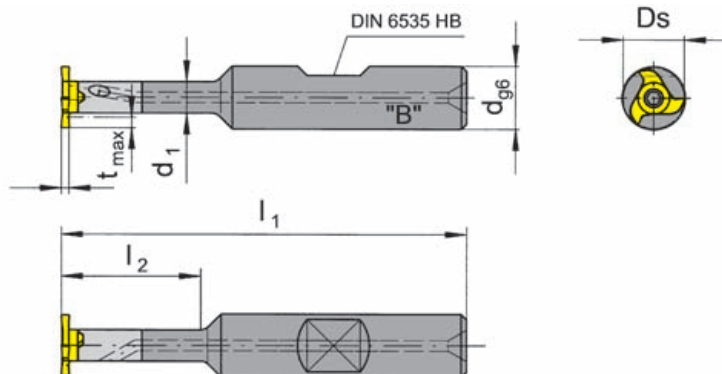

for use with Insert

Type U111
U308
111
308
608

Picture = right hand cutting version

Part number	l_1	l_2	d_1	d
MU308.0500.01B	3.740	1.142		
MU308.0500.02B	4.331	1.654	.315	.500
MU308.0500.03B	4.724	2.205		
MU308.0625.01B	4.331	1.299	.374	.625

Further sizes upon request

w, Ds, t_{max} see inserts

Dimensions in inch

Ordering note:All milling cutter shanks can be used for **right** and **left** hand inserts type 111.

Milling cutter shanks with damaged seating can be repaired by HORN.

For torque specifications of the screw, please see Technical Instructions.

Spare parts

Milling shank	Screw	TORX PLUS® Wrench
MU308.0...	3.5.12T10EP	T10PL

MILLING SHANK Type

M308

with through coolant supply

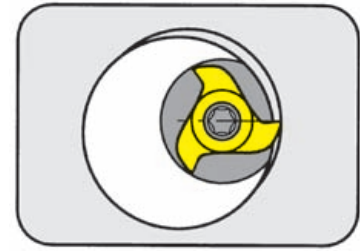

Cutting edge \varnothing

Ds 13.4/15.7 mm

Material of shank: Carbide - Giving a good vibration resistance

for use with Insert

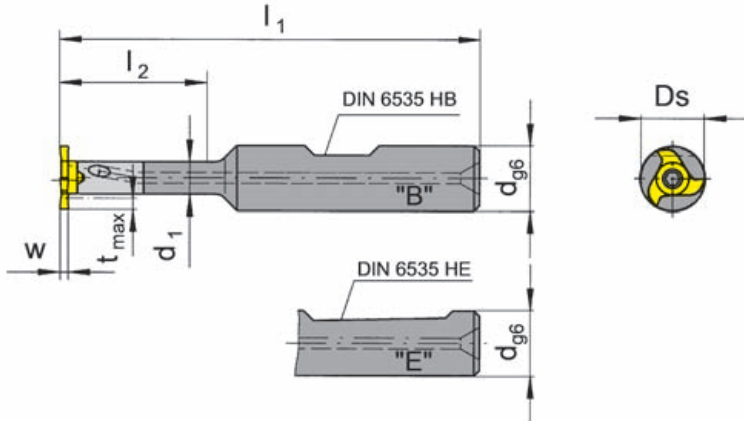

Type U111
U308
111
308
608

Picture = right hand cutting version

Part number	l_1	l_2	d_1	d	Form
M308.0012.01B	95	29	8	12	B
M308.0012.02B	110	42			
M308.0012.03B	120	56			
M308.0012.01E	95	29	8	12	E
M308.0012.02E	110	42			
M308.0012.03E	120	56			

Further sizes upon request

w, Ds, t_{max} see inserts

Dimensions in mm

Ordering note:

All milling cutter shanks can be used for **right** and **left** hand inserts type 111.

Milling cutter shanks with damaged seating can be repaired by HORN.

For torque specifications of the screw, please see Technical Instructions.

Spare parts

Milling shank	Screw	TORX PLUS® Wrench
M308.0012.0...	3.5.12T10EP	T10PL

MILLING SHANK Type

M308

with through coolant supply

Cutting edge \emptyset

Ds 13.4/15.7 mm

Material of shank: Carbide - Giving a good vibration resistance

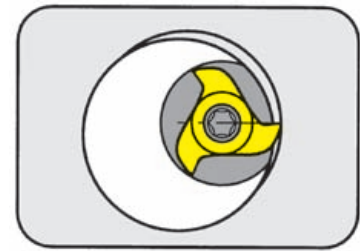

for use with Insert

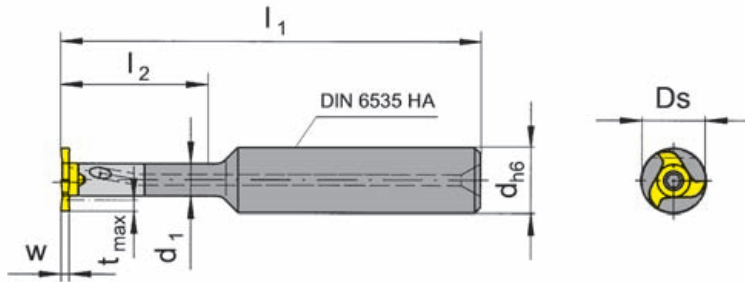
 Type U111
 U308
 111
 308
 608

Picture = right hand cutting version

Part number	l_1	l_2	d_1	d
M308.0012.01A	95	29	8	12
M308.0012.02A	110	42		
M308.0012.03A	120	56		

Further sizes upon request

w, Ds, t_{max} see inserts

Dimensions in mm

Ordering note:All milling cutter shanks can be used for **right** and **left** hand inserts type 111.

Milling cutter shanks with damaged seating can be repaired by HORN.

For torque specifications of the screw, please see Technical Instructions.

Spare parts

Milling shank	Screw	TORX PLUS® Wrench
M308.0012.0...	3.5.12T10EP	T10PL

MILLING SHANK Type

M308.ST

no coolant supply

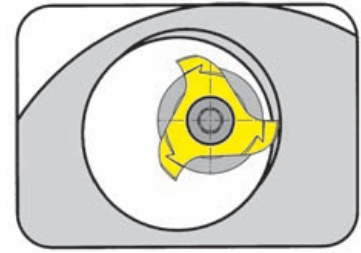

Cylindrical steel milling shank for collets Ds 13.4 / 15.7 mm

with cylindrical shank for CNC-lathes

for use with Insert

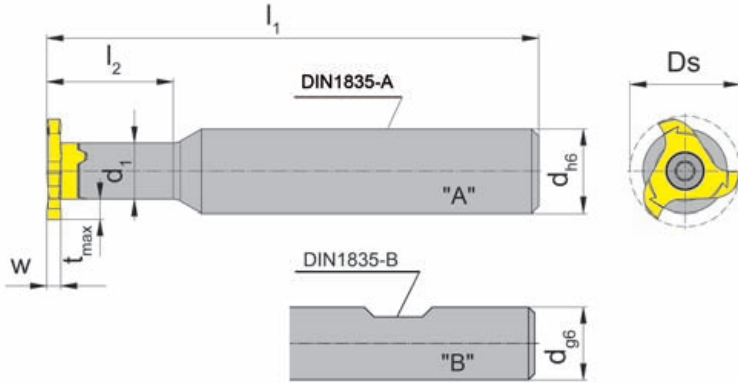

Type U11
U308
111
308
608

Picture = right hand cutting version

Part number	l_1	l_2	d_1	d	Form
M308.ST10.01A	60	18		10	A
M308.ST12.01A	70	18	8	12	
M308.ST13.01A	70	26		13	
M308.ST10.01B	60	18	8	10	B
M308.ST12.01B	70			12	

Further sizes upon request

w, Ds, t_{max} see inserts

Dimensions in mm

Ordering note:

All milling cutter shanks can be used for **right** and **left** hand inserts type 111.

For torque specifications of the screw, please see Technical Instructions.

Spare parts

Milling shank	Screw	TORX PLUS® Wrench
M308.ST1...	3.5.12T10EP	T10PL

SCREW-IN CUTTER Type

M308.M

no coolant supply

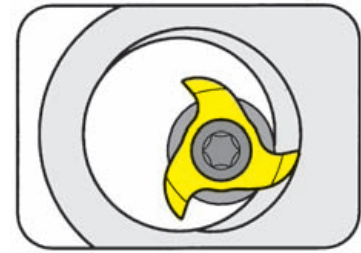

Screw-in Cutter for basic holder type WFB.20

for use with Insert

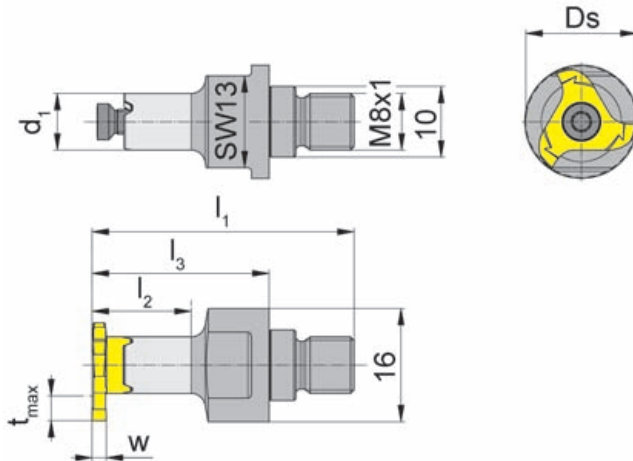
 Type U111
 U308
 111
 308
 608

Picture = right hand cutting version

Part number	l_1	l_2	l_3	d_1
M308.M081.01	37	14	25	8

Further sizes upon request

w, Ds, t_{max} see inserts

Dimensions in mm

All milling cutter shanks can be used for **right** and **left** hand inserts type 111.

For torque specifications of the screw, please see Technical Instructions.



Spare parts

Screw-in cutter	Screw	TORX PLUS® Wrench
M308.M081.01	3.5.12T10EP	T10PL

BASIC HOLDER Type

WFB

Basic shank WFB.20 for screw-in cutter

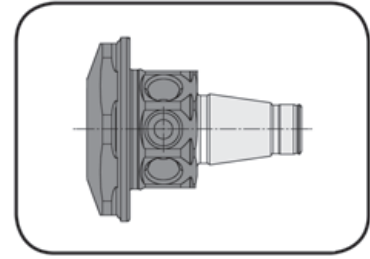

for use with Screw-in cutter

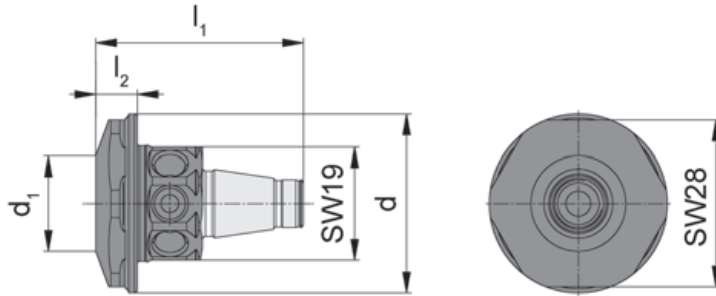

- Type
- M306.M081...
 - M308.M081...
 - M311.M081...
 - M313.M081...
 - M328.M081...
 - M332.M081...

Part number	l_1	l_2	d_1	d
WFB.2012.M081.01	35	7	16	30

Further sizes upon request

Dimensions in mm



MILLING SHANK Type

M308.ER

no coolant supply

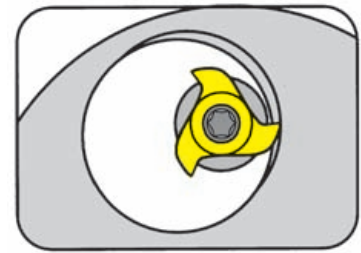

Milling shanks for collet chucks DIN6499-A (8°) Ds 13.4 / 15.7 mm

with ER taper for CNC-lathes

for use with Insert

Type U11
U308
111
308
608

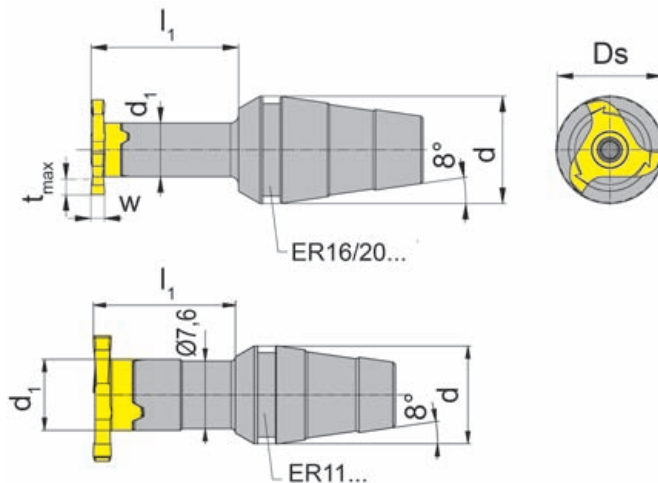

Picture = right hand cutting version

Part number	l_1	d_1	d	Clamping nut
M308.ER11.02	16		11	ER11.6499
M308.ER16.02	22	8	16	ER16.6499/ERM...
M308.ER20.02	22		20	ER20.6499/ERM...

Further sizes upon request

w, Ds, t_{max} see inserts

Dimensions in mm

Ordering note:

All milling cutter shanks can be used for **right** and **left** hand inserts type 111.

For torque specifications of the screw, please see Technical Instructions.

Clamping nut is not combined with milling shank - separate order required!

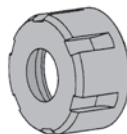

Spare parts

Milling shank	Screw	TORX PLUS® Wrench
M308.ER...	3.5.12T10EP	T10PL

INSERT Type

111

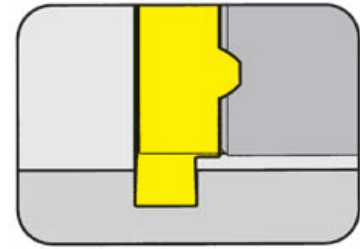

Depth of groove up to	.091"
Width of circlip Nw	.028 - .063"
Cutting edge Ø	Ds .528"

Widths for circlip grooves DIN 471/472

for use with Milling shank

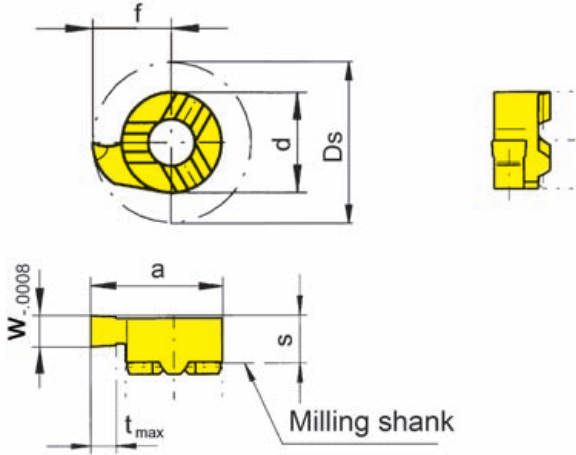

- Type
- MU308
 - M308
 - M308.ST
 - M308.ER
 - M308.M

R = right hand version shown

L = left hand version

Part number	Nw	w	s	f	a	d	t _{max}	Ds	Carbide grades			
									MG12	TN35	T125	TH35
R/L111.0070.00	.028	.029	.163				.047		▲/▲		▲/▲	
R/L111.0080.00	.031	.033	.163				.051		▲/▲		▲/▲	
R/L111.0090.00	.035	.037	.163				.059		▲/▲	▲/▲	▲/▲	▲/▲
R/L111.0110.00	.043	.047	.156	.264	.421	.315	.091	.528	▲/▲	▲/▲	▲/▲	▲/▲
R/L111.0130.00	.051	.055	.156				.091		▲/▲	▲/▲	▲/▲	▲/▲
R/L111.0160.00	.063	.067	.156				.091		▲/▲	▲/▲	▲/▲	▲/▲
									P	○	●	●
									M	●	●	●
									K	●	●	●
									N	●	●	●
									S	●	●	●
									H			

- ▲ on stock Δ 4 weeks
- main recommendation
- alternative recommendation
- uncoated grades
- coated grades
- brazed/Cermet

Dimensions in inch

Carbide grades

State R or L version

Note:

Inserts with width of groove w .029" - .039" are NOT face cutting!

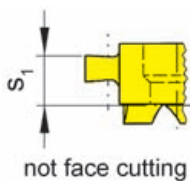

INSERT Type

111/U111

Depth of groove up to .091"
 Width of groove up to .125"
 Cutting edge \emptyset Ds .528"

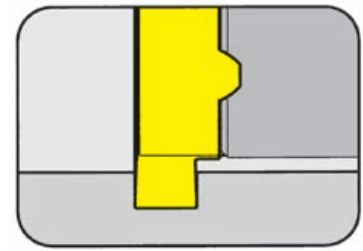

for use with Milling shank

Type MU308
 M308
 M308.ST
 M308.ER
 M308.M

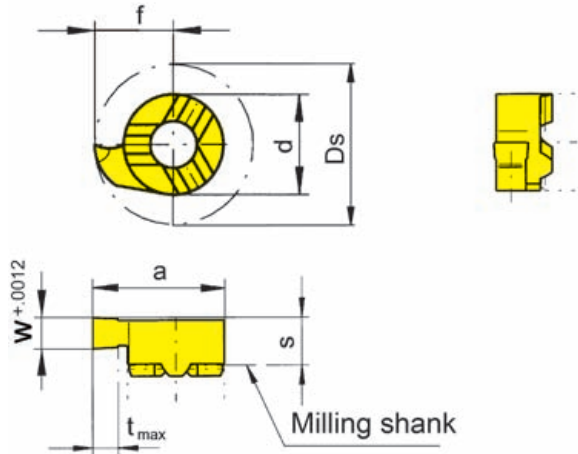

R = right hand version shown

L = left hand version

Part number	w	s	f	a	d	t _{max}	Ds	Carbide grades			
								MG12	TN35	T125	TF45
R/L111.0150.00	.059							▲/▲	▲/▲		
R/L111.0200.00	.079							▲/▲	▲/▲		
R/L111.0250.00	.098	.156	.264	.421	.315	.091	.528	▲/▲	▲/▲		
R/L111.0300.00	.118							▲/▲	▲/▲		
R/LU111.0046.00	.046							▲/	▲/▲	▲/	
R/LU111.0056.00	.056							▲/	▲/▲		
R/LU111.0062.00	.062	.156	.264	.421	.315	.091	.528	▲/	▲/▲	▲/	▲/
R/LU111.0078.00	.078								▲/▲		
R/LU111.0094.00	.094							▲/	▲/▲		
R/LU111.0125.00	.125								▲/▲		

- ▲ on stock ▲ 4 weeks
- main recommendation
- alternative recommendation
- uncoated grades
- coated grades
- brazed/Cermet

Dimensions in inch

State R or L version

	P	M	K	N	S	H
MG12	○	●	●	●	●	●
TN35	●	●	●	●	●	●
T125	●	●	●	●	●	●
TF45	●	●	●	●	●	●

Carbide grades

INSERT Type

111/U111

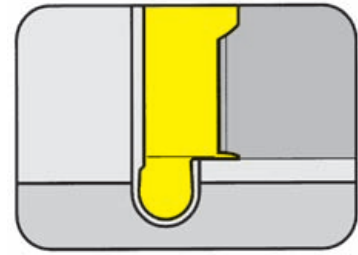

Depth of groove up to .091"
 Full radius r .015 - .059"
 Cutting edge \emptyset Ds .528"

for use with Milling shank

Type MU308
 M308
 M308.ST
 M308.ER
 M308.M

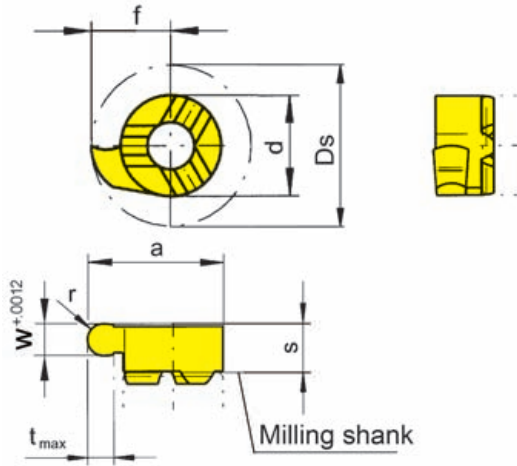

R = right hand version shown

L = left hand version

Full radius

Part number	w	r	s	f	a	d	t _{max}	Ds	Carbide grades				
									MG12	TN35	T125	TF45	TH35
R/L111.0004.08	.031	.016								▲/▲			▲/▲
R/L111.0006.12	.047	.024							▲/▲	▲/▲			▲/▲
R/L111.0009.18	.071	.035	.156	.264	.421	.315	.091	.528	▲/▲	▲/▲			▲/▲
R/L111.0010.20	.079	.039							▲/▲	▲/▲			▲/▲
R/L111.0015.30	.118	.059							▲/▲	▲/▲			▲/▲
R/LU111.0015.31	.031	.015								▲/▲			
R/LU111.0023.46	.046	.023							▲/▲	▲/▲			
R/LU111.0031.62	.062	.031	.156	.264	.421	.315	.091	.528	▲/▲	▲/▲		▲/▲	
R/LU111.0039.78	.078	.039							▲/▲	▲/▲			
R/LU111.0047.94	.094	.047							▲/▲	▲/▲			

- ▲ on stock Δ 4 weeks
- main recommendation
- alternative recommendation
- uncoated grades
- coated grades
- brazed/Cermet

	P	M	K	N	S	H
MG12	○	●	●	●	●	●
TN35	●	●	●	●	●	●
T125	●	●	●	●	●	●
TF45	●	●	●	●	●	●
TH35	●	●	●	●	●	●

Dimensions in inch

Carbide grades

State R or L version

INSERT Type

308

Depth of groove up to	.138"
Width of circlip Nw	.043 - .063"
Cutting edge Ø	Ds .618"

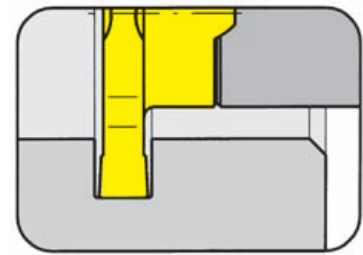

Widths for circlip grooves DIN 471/472

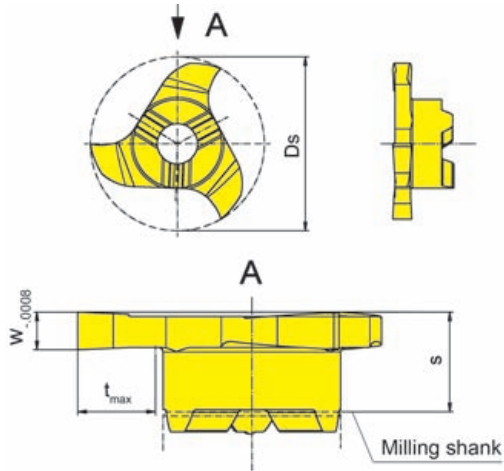

for use with Milling shank

- Type MU308
M308
M308.ST
M308.ER
M308.M

Picture = right hand cutting version

Part number	Nw	w	s	t _{max}	Ds	Carbide grades				
						MG12	TN35	T125	AS45	TF45
308.0110.00	.043	.048					▲			△
308.0130.00	.051	.056	.177	.138	.618		▲		▲	△
308.0160.00	.063	.067					▲		▲	△
						P	•	•	•	•
						M	•	•	•	•
						K	•	•	•	•
						N	•	•	○	•
						S	•	•	•	•
						H				

- ▲ on stock △ 4 weeks
- main recommendation
- alternative recommendation
- uncoated grades
- coated grades
- brazed/Cermet

Dimensions in inch

Carbide grades

INSERT Type

308/U308

Depth of groove up to .138"
 Width of groove up to .125"
 Cutting edge Ø Ds .618"

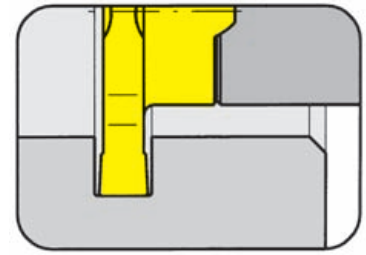

for use with Milling shank

Type MU308
 M308
 M308.ST
 M308.ER
 M308.M

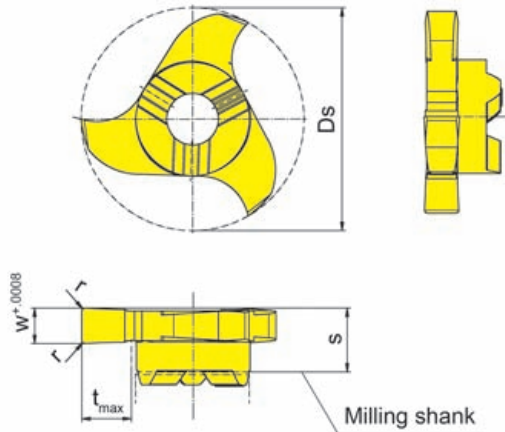

Picture = right hand cutting version

Part number	w	r	s	t _{max}	Ds	Carbide grades				
						MG12	TN35	AS45	TF45	
308.0150.00	.059	-				▲	▲	▲	▲	
308.0200.00	.079	.008	.177	.138	.618		▲	▲		
308.0250.00	.098	.008				▲	▲	▲	▲	
U308.0046.00	.046	-	.177	.138	.618		▲			
U308.0062.00	.062						▲			
U308.0046.08	.046		.177	.138	.618		▲		▲	
U308.0062.08	.062	.008	.177	.138	.618		▲		▲	
U308.0094.08	.094						▲		▲	
U308.0125.08	.125						▲		▲	
▲ on stock Δ 4 weeks ● main recommendation ○ alternative recommendation ■ uncoated grades ■ coated grades ■ brazed/Cermet						P	○	●	●	●
						M	●	●	●	●
						K	●	●	●	●
						N	●	●	○	●
						S	●	●	●	●
						H				

Dimensions in inch

Carbide grades

INSERT Type

308

machining of aluminium

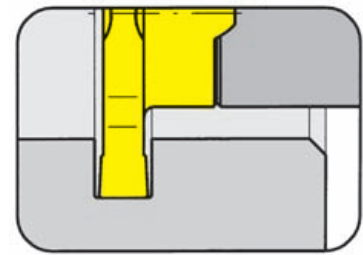

Depth of groove up to	.138"
Width of circlip Nw	.043 - .063"
Cutting edge Ø	Ds .618"

Widths for circlip grooves DIN 471/472

for use with Milling shank

- Type
- MU308
 - M308
 - M308.ST
 - M308.ER
 - M308.M

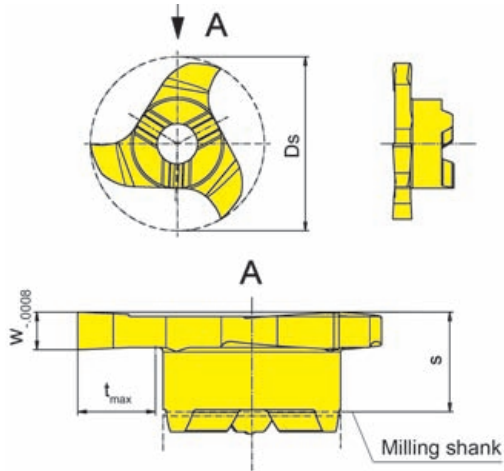

Picture = right hand cutting version

Part number	Nw	w	s	t _{max}	Ds	Carbide grades	
						MG12	TI25
308.0110.40	.043	.048	.177	.138	.618		Δ
308.0130.40	.051	.056					Δ
308.0160.40	.063	.067					Δ
						P	•
						M	•
						K	•
						N	•
						S	•
						H	

- ▲ on stock Δ 4 weeks
- main recommendation
- alternative recommendation
- uncoated grades
- coated grades
- brazed/Cermet

Dimensions in inch

Carbide grades

INSERT Type

308

machining of aluminium

Depth of groove up to	.138"
Width of groove up to	.098"
Cutting edge Ø	Ds .618"

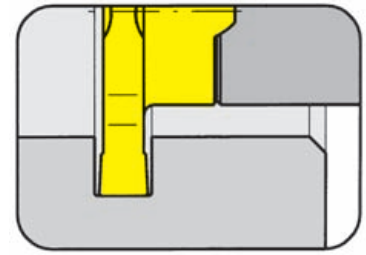

for use with Milling shank

- Type
- MU308
 - M308
 - M308.ST
 - M308.ER
 - M308.M

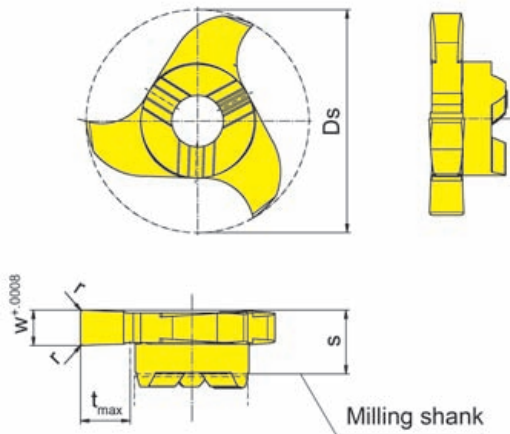

Picture = right hand cutting version

Part number	w	r	s	t _{max}	Ds	Carbide grades	
						MG12	TI25
308.0150.40	.059	-					▲
308.0200.40	.079	.008	.177	.138	.618		▲
308.0250.40	.098	.008					▲
						P	•
						M	•
						K	•
						N	•
						S	•
						H	•

- ▲ on stock Δ 4 weeks
- main recommendation
- o alternative recommendation
- uncoated grades
- coated grades
- brazed/Cermet

Dimensions in inch

Carbide grades

INSERT Type

308/U308

Depth of groove up to .138"
 Full radius r .031 - .047"
 Cutting edge \emptyset Ds .618"

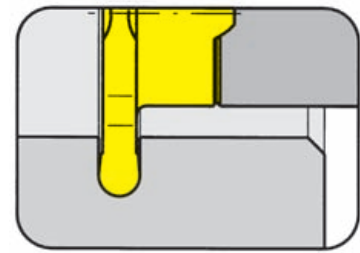

for use with Milling shank

Type MU308
 M308
 M308.ST
 M308.ER
 M308.M

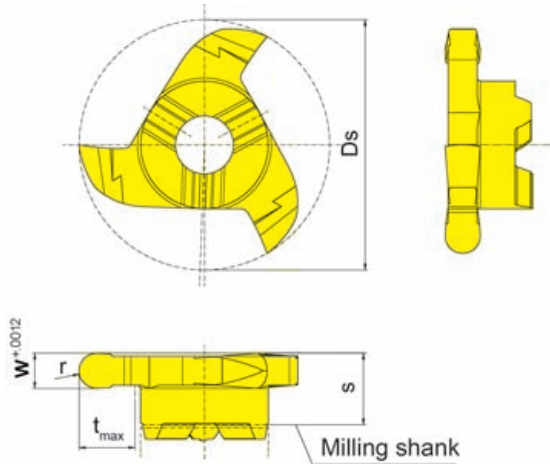

Picture = right hand cutting version

Full radius

Part number	w	r	s	t _{max}	Ds	Carbide grades				
						MG12	TN35	TI25	AS45	TF45
308.0011.22	.087	.043	.177	.138	.618		▲		▲	▲
U308.0031.62	.062	.031	.177	.138	.618		▲			
U308.0047.94	.094	.047	.177	.138	.618		▲	Δ		
▲ on stock Δ 4 weeks ● main recommendation ○ alternative recommendation ■ uncoated grades ■ coated grades ■ brazed/Cermet						P	●	●	●	●
						M	●	●	●	●
						K	●	●	●	●
						N	●	●	○	●
						S	●	●	●	●
						H				

Dimensions in inch

INSERT Type

608

Depth of groove up to	.138"
Width of groove up to	.098"
Cutting edge Ø	Ds .618"

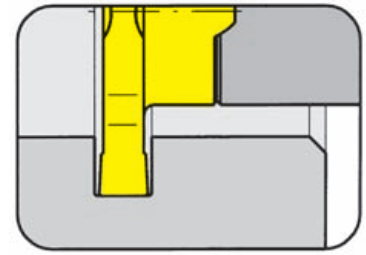

for use with Milling shank

- Type
- MU308
 - M308
 - M308.ST
 - M308.ER
 - M308.M

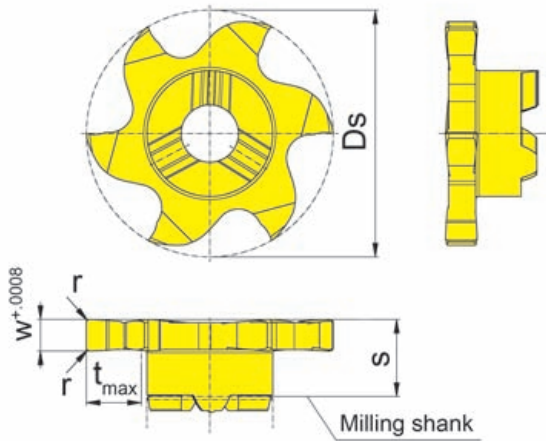

Picture = right hand cutting version

Part number	w	r	s	t _{max}	Ds	Carbide grades			
						MG12	T125	TA45	AS45
608.0150.00	.059	-					▲		▲
608.0200.00	.079	.008	.193	.138	.618		▲		▲
608.0250.00	.098	.008					▲		▲
						P	•	•	•
						M	•	•	•
						K	•	•	•
						N	•	•	○
						S	•	•	•
						H			

- ▲ on stock Δ 4 weeks
- main recommendation
- alternative recommendation
- uncoated grades
- coated grades
- brazed/Cermet

Dimensions in inch

Carbide grades

Spline Milling

Example:

- Single tooth spline profile
- Carbide shank type M335

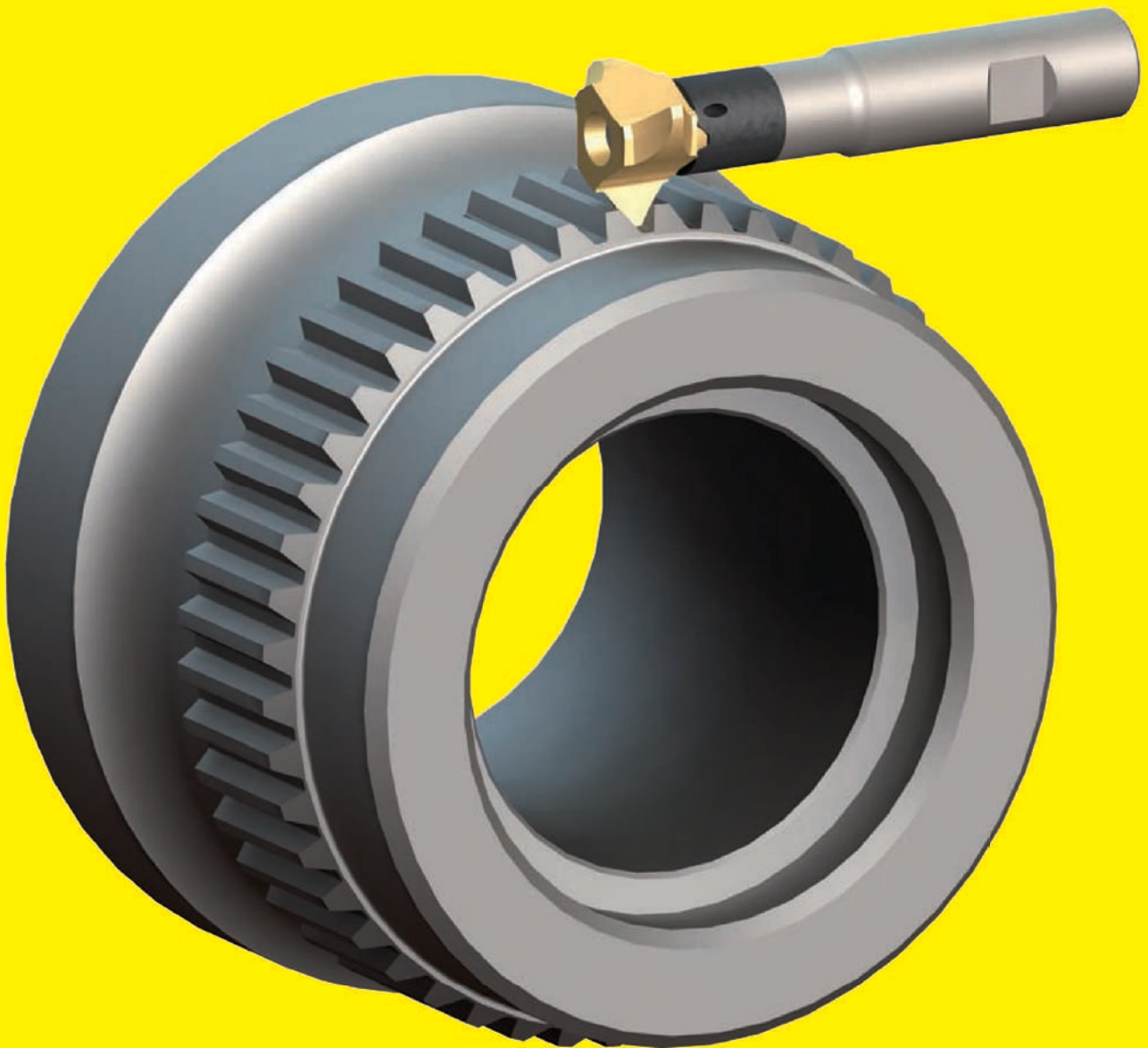

For further information, please contact HORN USA.

MILLING SHANK type **MU / M311**
from bore \varnothing .709" (18.0 mm)

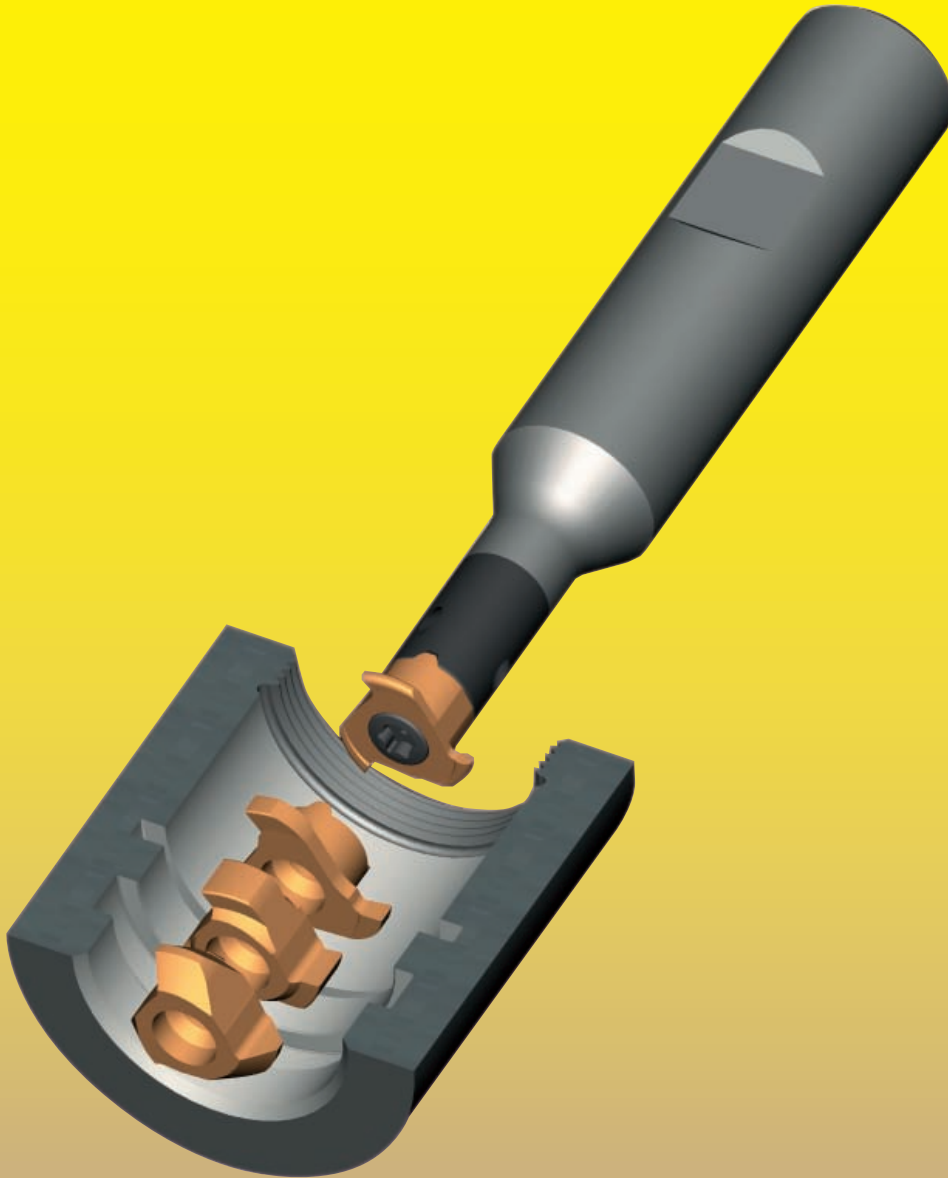

MILLING SHANK Type

MU311

with through coolant supply

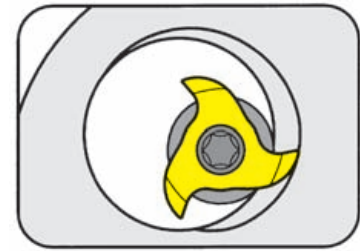
Cutting edge \varnothing

Ds .697"

Material of shank: Carbide - Giving a good vibration resistance

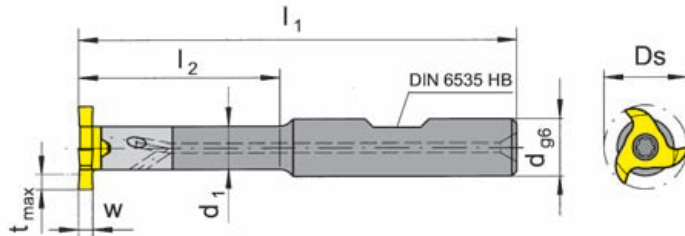

for use with Insert

 Type U311
 311
 611

Picture = right hand cutting version

Part number	l_1	l_2	d_1	d
MU311.0500.01B	3.937	1.260		
MU311.0500.02B	3.937	1.772	.354	.500
MU311.0500.03B	4.724	2.520		
MU311.0625.01B	3.937	1.260		
MU311.0625.02B	4.331	1.772	.354	.625
MU311.0625.03B	5.118	2.520		

Further sizes upon request

w, Ds, t_{max} see inserts

Dimensions in inch

Ordering note:

Milling cutter shanks with damaged seating can be repaired by HORN.

For torque specifications of the screw, please see Technical Instructions.

Spare parts

Milling shank	Screw	TORX PLUS® Wrench
MU311.0...	4.14T15P	T15PQ

MILLING SHANK Type

M311

with through coolant supply

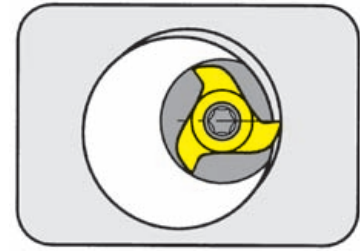

Cutting edge \varnothing

Ds 17.7 mm

Material of shank: Carbide - Giving a good vibration resistance

for use with Insert

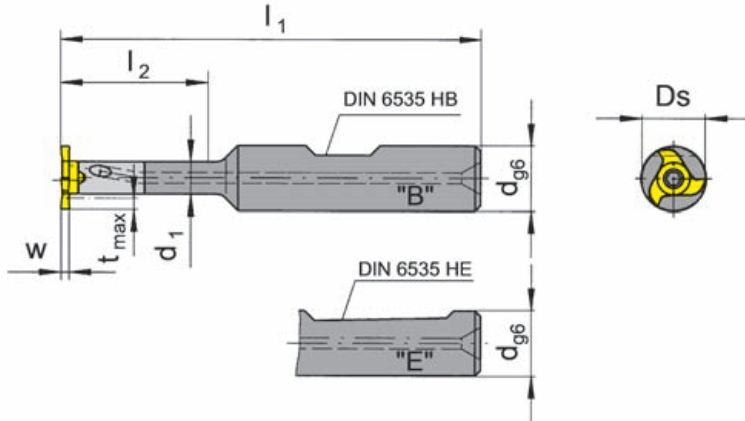

Type U311
311
611

Picture = right hand cutting version

Part number	l_1	l_2	d_1	d	Form
M311.0012.01B	100	32	9	12	B
M311.0012.02B	100	45		12	
M311.0012.03B	120	64		12	
M311.0016.01B	100	32		16	
M311.0016.02B	110	45		16	
M311.0016.03B	130	64		16	
M311.0012.01E	100	32	9	12	E
M311.0012.02E	100	45		12	
M311.0012.03E	120	64		12	
M311.0016.01E	100	32		16	
M311.0016.02E	110	45		16	
M311.0016.03E	130	64		16	

Further sizes upon request

w, Ds, t_{max} see inserts

Dimensions in mm

Ordering note:

Milling cutter shanks with damaged seating can be repaired by HORN.

For torque specifications of the screw, please see Technical Instructions.

Spare parts

Milling shank	Screw	TORX PLUS® Wrench
M311.001...	4.14T15P	T15PQ

MILLING SHANK Type

M311

with through coolant supply

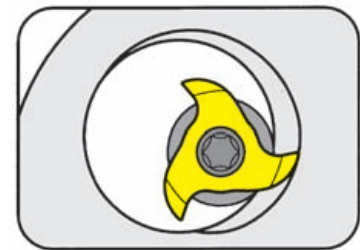
Cutting edge \varnothing

Ds 17.7 mm

Material of shank: Carbide - Giving a good vibration resistance

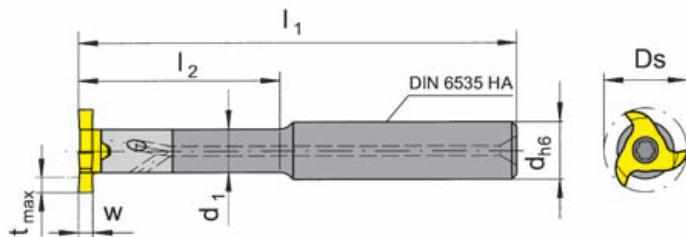

for use with Insert

 Type U311
 311
 611

Picture = right hand cutting version

Part number	l_1	l_2	d_1	d
M311.0012.01A	100	32		
M311.0012.02A	100	45	9	12
M311.0012.03A	120	64		
M311.0016.01A	100	32		
M311.0016.02A	110	45	9	16
M311.0016.03A	130	64		

Further sizes upon request

w, Ds, t_{max} see inserts

Dimensions in mm

Ordering note:

Milling cutter shanks with damaged seating can be repaired by HORN.

For torque specifications of the screw, please see Technical Instructions.

Spare parts

Milling shank	Screw	TORX PLUS® Wrench
M311.001...	4.14T15P	T15PQ

MILLING SHANK Type

M311.ST

no coolant supply

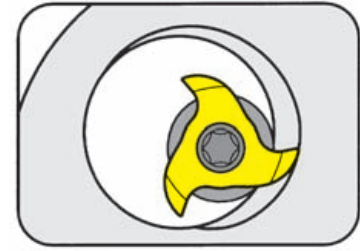

Cylindrical steel milling shank for collets Ds 17.7 mm

with cylindrical shank for CNC-lathes

for use with Insert

Type U311
311
611

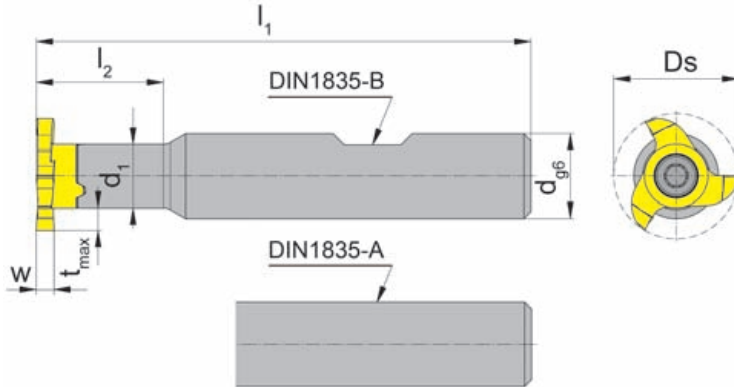

Picture = right hand cutting version

Part number	l_1	l_2	d_1	d	Form
M311.ST10.01A	60	18		10	A
M311.ST12.01A	70	18	9	12	
M311.ST13.01A	70	26		13	
M311.ST16.01A	80	26		16	
M311.ST10.01B	60		9	10	B
M311.ST12.01B	70	18		12	

Further sizes upon request

w, Ds, t_{max} see inserts

Dimensions in mm

For torque specifications of the screw, please see Technical Instructions.

Spare parts

Milling shank	Screw	TORX PLUS® Wrench
M311.ST1...	4.14T15P	T15PQ

SCREW-IN CUTTER Type

M311.M

no coolant supply

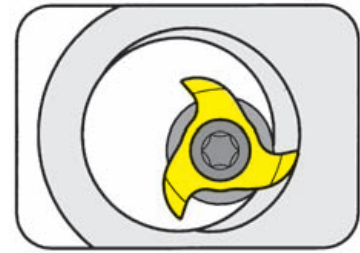

Screw-in Cutter for basic holder type WFB.20

for use with Insert

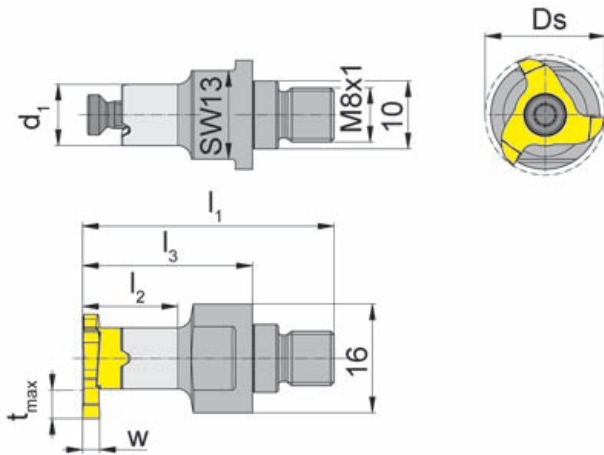
 Type U311
 311
 611

Picture = right hand cutting version

Part number	l_1	l_2	l_3	d_1
M311.M081.01	37	14	25	9

Further sizes upon request

w, Ds, t_{max} see inserts

Dimensions in mm

For torque specifications of the screw, please see Technical Instructions.



Spare parts

Screw-in cutter	Screw	TORX PLUS® Wrench
M311.M081.01	4.14T15P	T15PQ

BASIC HOLDER Type

WFB

Basic shank WFB.20 for screw-in cutter

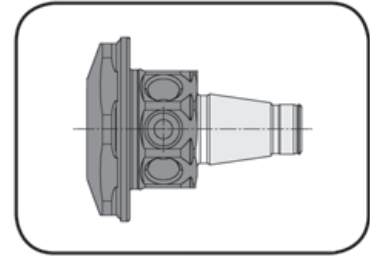

for use with Screw-in cutter

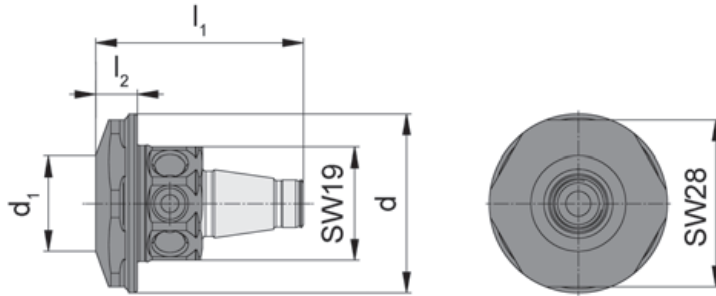

- Type
- M306.M081...
 - M308.M081...
 - M311.M081...
 - M313.M081...
 - M328.M081...
 - M332.M081...

Part number	l_1	l_2	d_1	d
WFB.2012.M081.01	35	7	16	30

Further sizes upon request

Dimensions in mm



MILLING SHANK Type

M311.ER

no coolant supply

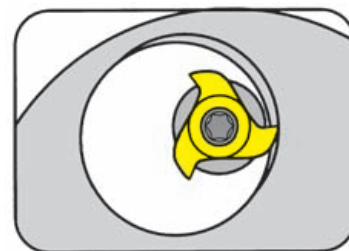

Milling shanks for collet chucks DIN6499-A (8°) Ds 17.7 mm

with ER taper for CNC-lathes

for use with Insert

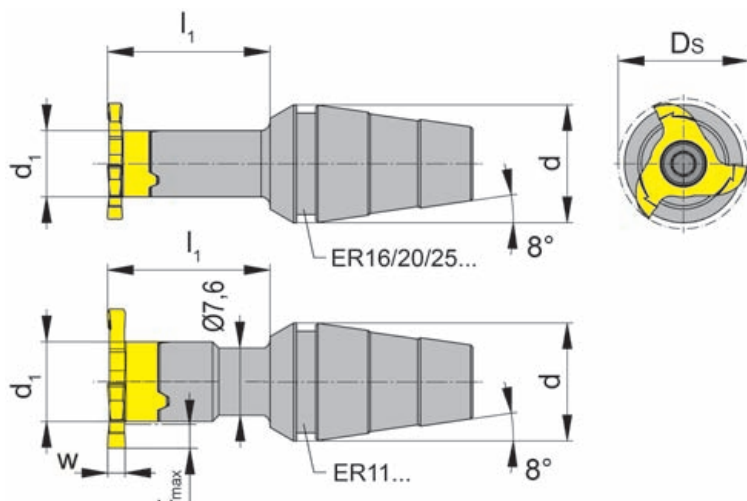
 Type U311
 311
 611

Picture = right hand cutting version

Part number	l_1	d_1	d	Clamping nut
M311.ER11.02			11	ER11.6499
M311.ER16.02	22	9	16	ER16.6499/ERM...
M311.ER20.02			20	ER20.6499/ERM...
M311.ER25.02			25	ER25.6499

Further sizes upon request

w, Ds, t_{max} see inserts

Dimensions in mm

For torque specifications of the screw, please see Technical Instructions.

Ordering note:

Clamping nut is not combined with milling shank - separate order required!

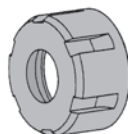
**Spare parts**

Milling shank	Screw	TORX PLUS® Wrench
M311.ER...	4.14T15P	T15PQ

INSERT Type

311

Depth of groove up to	.138"
Width of circlip Nw	.043 - .063"
Cutting edge Ø	Ds .697"

Widths for circlip grooves DIN 471/472

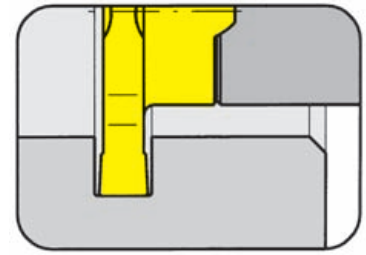

for use with Milling shank

- Type
- MU311
 - M311
 - M311.ST
 - M311.ER
 - M311.M

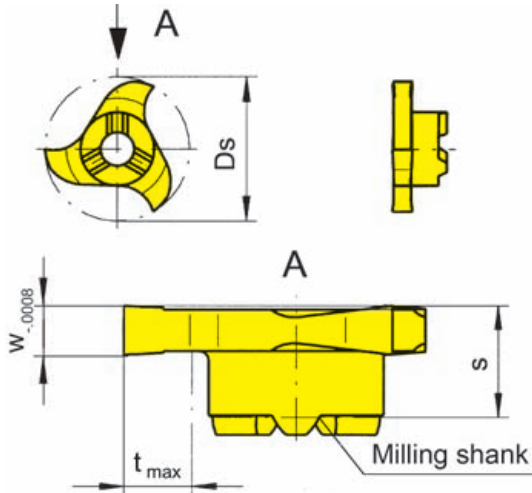

Picture = right hand cutting version

Part number	Nw	w	s	t _{max}	Ds	Carbide grades		
						MG12	TN35	AS45
311.0110.00	.043	.048					▲	
311.0130.00	.051	.056	.226	.138	.697		▲	▲
311.0160.00	.063	.067					▲	▲
						P	•	•
						M	•	•
						K	•	•
						N	•	○
						S	•	•
						H		

- ▲ on stock Δ 4 weeks
- main recommendation
- alternative recommendation
- uncoated grades
- coated grades
- brazed/Cermet

Dimensions in inch

Carbide grades

INSERT Type

311/U311

Depth of groove up to .138"
 Width of groove up to .125"
 Cutting edge \emptyset Ds .697"

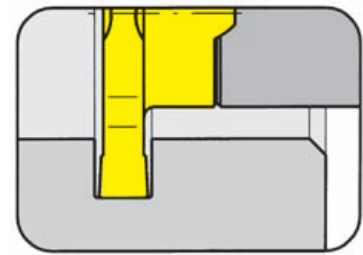

for use with Milling shank

Type MU311
 M311
 M311.ST
 M311.ER
 M311.M

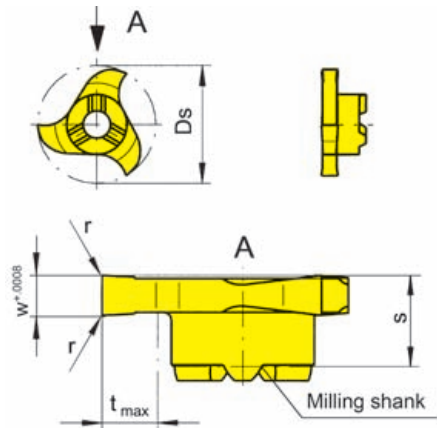

Picture = right hand cutting version

Part number	w	r	s	t _{max}	Ds	Carbide grades			
						MG12	TN35	AS45	TF45
311.0150.00	.059	-					▲	▲	
311.0200.00	.079	.008	.226	.138	.697	▲	▲	▲	
311.0250.00	.098	.008					▲	▲	
311.0300.00	.118	.008				▲	▲	▲	
U311.0046.00	.046						▲		
U311.0056.00	.056	-	.226	.138	.697		▲		
U311.0062.00	.062						▲		
U311.0046.08	.046						▲		
U311.0062.08	.062						▲		
U311.0078.08	.078	.008	.226	.138	.697	▲	▲		
U311.0094.08	.094					▲	▲		
U311.0125.08	.125					▲	▲		▲
						P	o	•	•
						M	•	•	•
						K	•	•	•
						N	•	•	o
						S	•	•	•
						H			

Dimensions in inch

- ▲ on stock Δ 4 weeks
- main recommendation
- o alternative recommendation
- uncoated grades
- coated grades
- brazed/Cermet

Carbide grades

INSERT Type

311

machining of aluminium

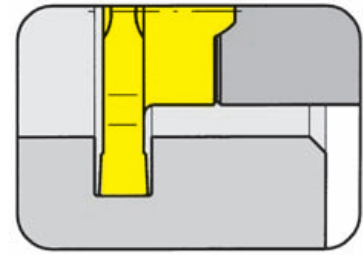

Depth of groove up to	.138"
Width of circlip Nw	.043 - .063"
Cutting edge Ø	Ds .697"

Widths for circlip grooves DIN 471/472

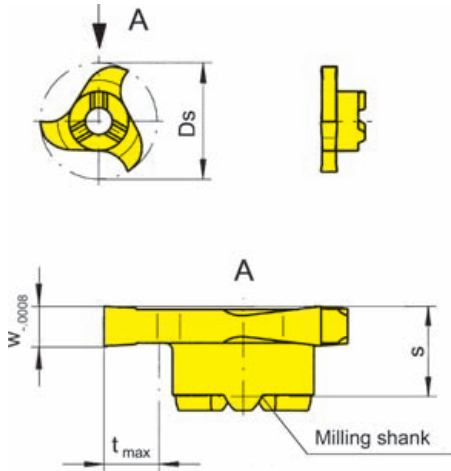

for use with Milling shank

- Type
- MU311
 - M311
 - M311.ST
 - M311.ER
 - M311.M

Picture = right hand cutting version

Part number	Nw	w	s	t _{max}	Ds	Carbide grades	
						MG12	TI25
311.0110.40	.043	.048					▲
311.0130.40	.051	.056	.226	.138	.697		▲
311.0160.40	.063	.067					▲
						P	•
						M	•
						K	•
						N	•
						S	•
						H	•

- ▲ on stock Δ 4 weeks
- main recommendation
- o alternative recommendation
- uncoated grades
- coated grades
- brazed/Cermet

Dimensions in inch

Carbide grades

INSERT Type

311

machining of aluminium

Depth of groove up to	.138"
Width of groove up to	.118"
Cutting edge \emptyset	Ds .697"

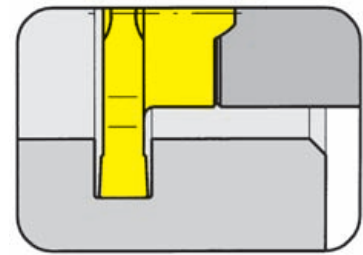

for use with Milling shank

- Type
- MU311
 - M311
 - M311.ST
 - M311.ER
 - M311.M

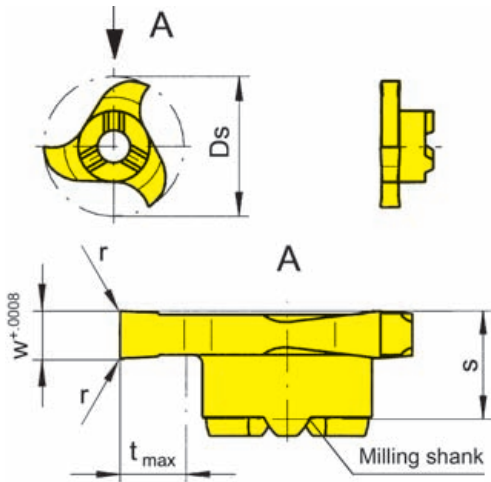

Picture = right hand cutting version

Part number	w	r	s	t _{max}	Ds	Carbide grades	
						MG12	TI25
311.0150.40	.059	-					▲
311.0200.40	.079	.008					▲
311.0250.40	.098	.008	.226	.138	.697		▲
311.0300.40	.118	.008					▲
						P	•
						M	•
						K	•
						N	•
						S	•
						H	•

- ▲ on stock Δ 4 weeks
- main recommendation
- o alternative recommendation
- uncoated grades
- coated grades
- brazed/Cermet

Dimensions in inch

Carbide grades

INSERT Type

311/U311

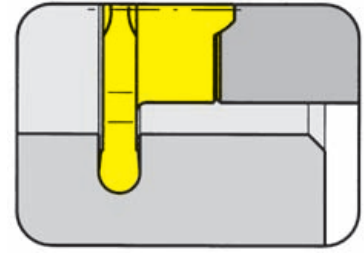

Depth of groove up to	.138"
Full radius	r .031 - .062"
Cutting edge \emptyset	Ds .697"

for use with Milling shank

- Type
- MU311
 - M311
 - M311.ST
 - M311.ER
 - M311.M

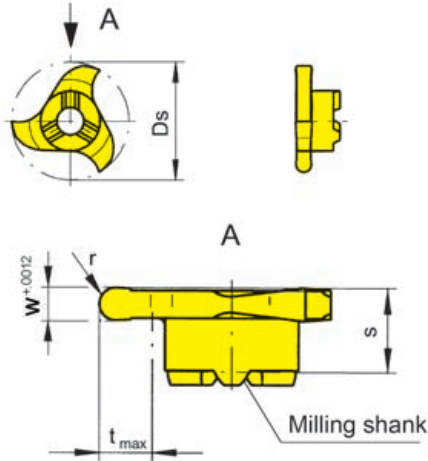

Picture = right hand cutting version

Full radius

Part number	w	r	s	t _{max}	Ds	Carbide grades				
						MG12	TN35	T125	AS45	TF45
311.0011.22	.087	.043	.226	.138	.697		▲		▲	
U311.0031.62	.062	.031					▲			
U311.0047.94	.094	.047	.226	.138	.697		▲			
U311.0062.125	.125	.062					▲			Δ
▲ on stock Δ 4 weeks ● main recommendation ○ alternative recommendation ■ uncoated grades ■ coated grades ■ brazed/Cermet						P	●	●	●	●
						M	●	●	●	●
						K	●	●	●	●
						N	●	○	●	●
						S	●	●	●	●
						H				

Dimensions in inch

INSERT Type

611

Depth of groove up to	.138"
Width of circlip Nw	.043 - .063"
Cutting edge Ø	Ds .697"

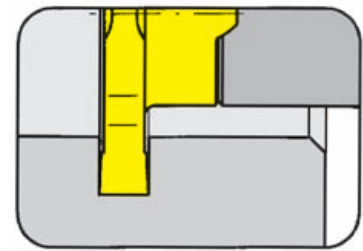

Widths for circlip grooves DIN 471/472

for use with Milling shank

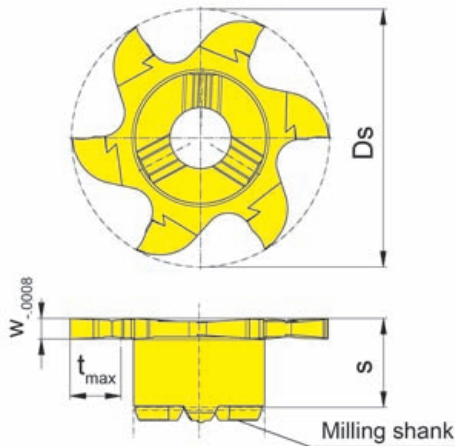

- Type
- MU311
 - M311
 - M311.ST
 - M311.ER
 - M311.M

Picture = right hand cutting version

Part number	Nw	w	s	t _{max}	Ds	Carbide grades		
						MG12	T125	AS45
611.0110.00	.043	.048					▲	
611.0130.00	.051	.056	.240	.138	.697		▲	▲
611.0160.00	.063	.067					▲	▲
						P	•	•
						M	•	•
						K	•	•
						N	•	○
						S	•	•
						H		

- ▲ on stock Δ 4 weeks
- main recommendation
- alternative recommendation
- uncoated grades
- coated grades
- brazed/Cermet

Dimensions in inch

Carbide grades

INSERT Type

611

Depth of groove up to	.138"
Width of groove up to	.118"
Cutting edge \emptyset	Ds .697"

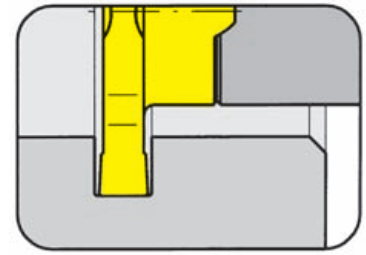

for use with Milling shank

- Type MU311
M311
M311.ST
M311.ER
M311.M

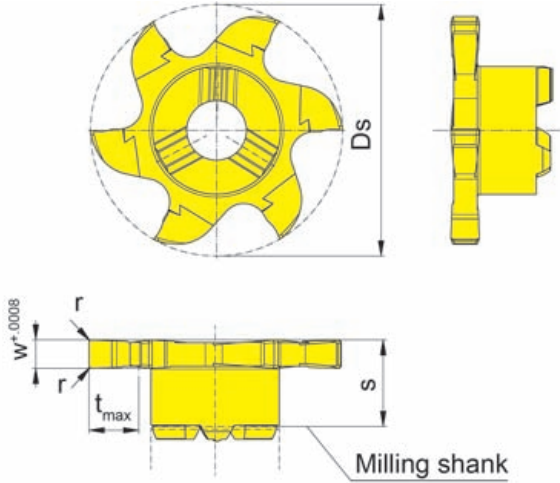

Picture = right hand cutting version

Part number	w	r	s	t _{max}	Ds	Carbide grades		
						MG12	T125	AS45
611.0150.00	.059	-					▲	▲
611.0200.00	.079	.008	.240	.138	.697		▲	▲
611.0250.00	.098	.008					▲	▲
611.0300.00	.118	.008					▲	▲
						P	•	•
						M	•	•
						K	•	•
						N	•	○
						S	•	•
						H		

- ▲ on stock Δ 4 weeks
- main recommendation
- alternative recommendation
- uncoated grades
- coated grades
- brazed/Cermet

Dimensions in inch



VDI Tool Adaptor and Square shank holder with through coolant

Direct cutting edge coolant



HORN - LEADERS IN GROOVING TECHNOLOGY

For further information, please contact HORN USA.

MILLING SHANK type

MU / M116

from bore

non rotating \varnothing .630" (16.0 mm)
rotating \varnothing .803" (20.4 mm)

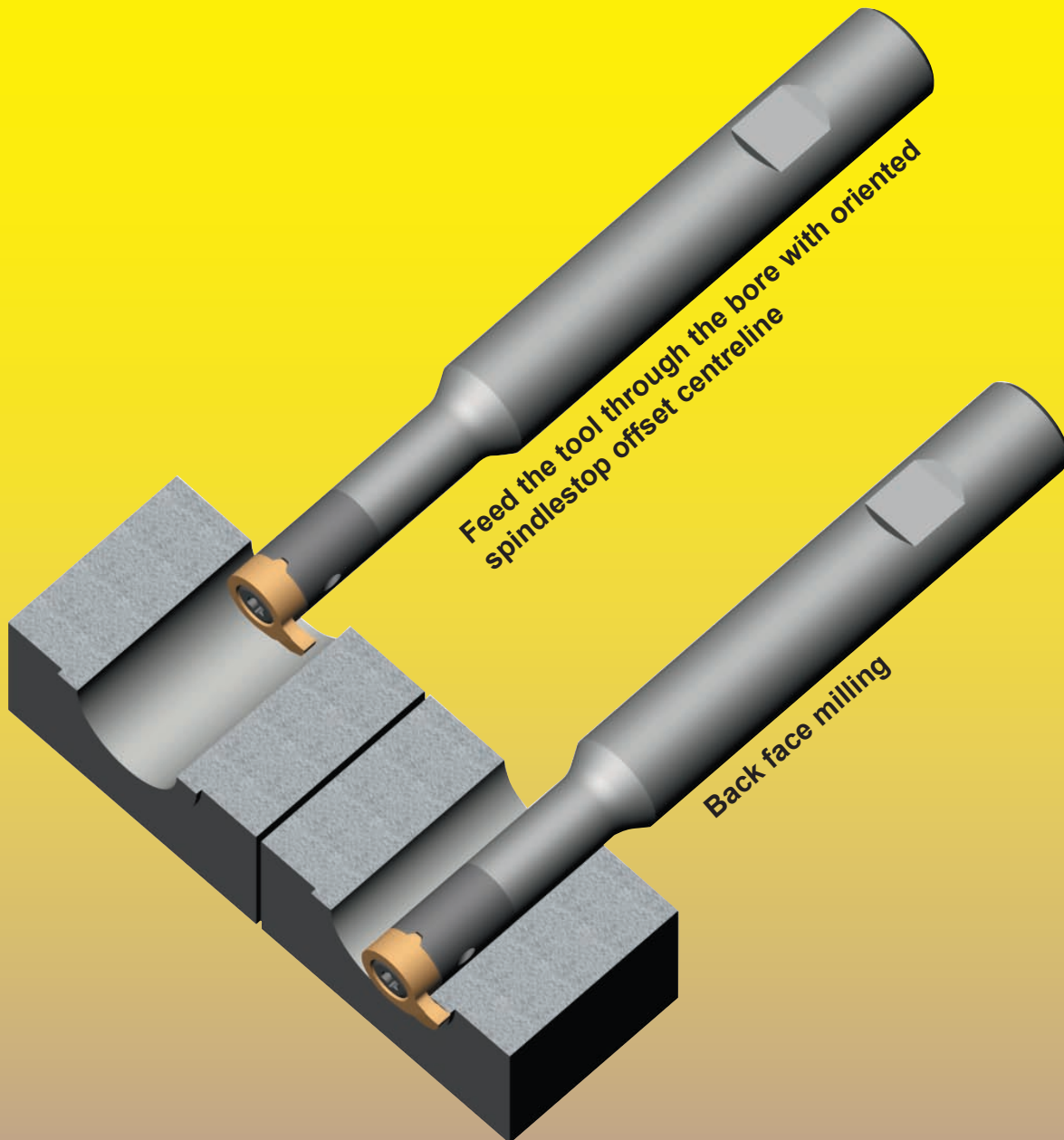

MILLING SHANK Type

MU116

with through coolant supply

Cutting edge \varnothing

Ds .803"

Material of shank: Carbide - Giving a good vibration resistance

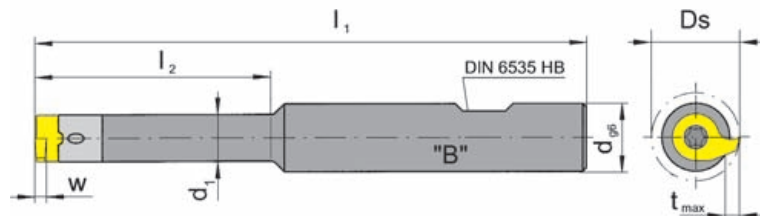

for use with Insert

Type U116
116

Picture = right hand cutting version

Part number	l_1	l_2	d_1	d
MU116.0625.01B	5.118	1.575		
MU116.0625.02B	5.118	2.205	.433	.625
MU116.0625.03B	5.906	3.150		

Further sizes upon request

w, Ds, t_{max} see inserts

Dimensions in inch

Note from \varnothing 16 mm:

Only back face milling with oriented spindlestop offset of centerline.

Ordering note:All milling cutter shanks can be used for **right** and **left** hand inserts type 116.

Milling cutter shanks with damaged seating can be repaired by HORN.

For torque specifications of the screw, please see Technical Instructions.

Spare parts

Milling shank	Screw	TORX PLUS® Wrench
MU116.0625.0...	5.13T20EP	T20PQ

MILLING SHANK Type

M116

with through coolant supply

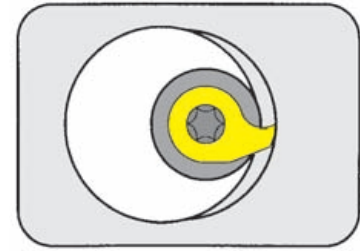

Cutting edge \varnothing

Ds 20.4 mm

Material of shank: Carbide - Giving a good vibration resistance

for use with Insert

Type U116
116

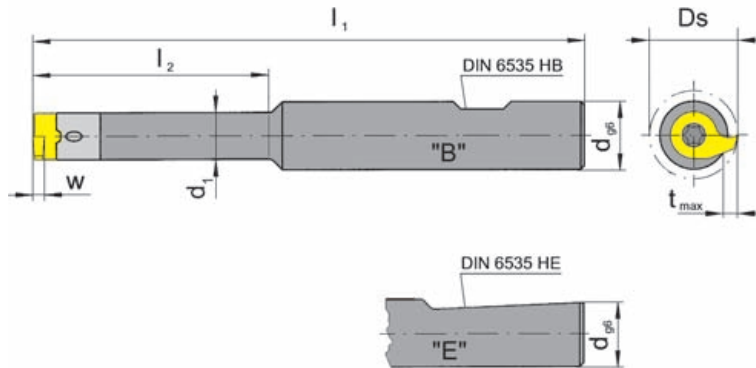

Picture = right hand cutting version

Part number	l_1	l_2	d_1	d	Form
M116.0012.01B M116.0012.02B	130	40 56	11	12	B
M116.0016.01B M116.0016.02B M116.0016.03B	130 130 150	40 56 80	11	16	B
M116.0016.01E M116.0016.02E M116.0016.03E	130 130 150	40 56 80	11	16	E

Further sizes upon request

w, Ds, t_{max} see inserts

Dimensions in mm

Note from \varnothing 16 mm:

Only back face milling with oriented spindlestop offset of centerline.

Ordering note:

All milling cutter shanks can be used for **right** and **left** hand inserts type 116.

Milling cutter shanks with damaged seating can be repaired by HORN.

For torque specifications of the screw, please see Technical Instructions.

Spare parts

Milling shank	Screw	TORX PLUS® Wrench
M116.001...	5.13T20EP	T20PQ

INSERT Type

116/U116

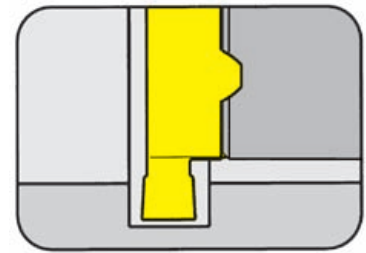

Depth of groove up to	.169"
Width of groove	.046 - .157"
Cutting edge Ø	Ds .803"

for use with Milling shank

Type MU116
M116

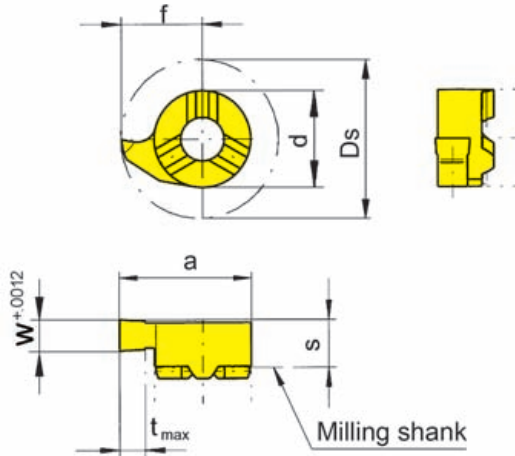

R = right hand version shown

L = left hand version

Part number	w	s	f	a	d	t _{max}	Ds	Carbide grades				
								MG12	TN35	T125	TF45	TH35
R/L116.0200.00	.079							▲/▲	▲/▲			▲/▲
R/L116.0250.00	.098							▲/▲	▲/▲			▲/▲
R/L116.0300.00	.118	.209	.402	.618	.433	.169	.803	▲/▲	▲/▲			▲/▲
R/L116.0350.00	.138							▲/▲	▲/▲			▲/▲
R/L116.0400.00	.157							▲/▲	▲/▲			▲/▲
R/LU116.0046.00	.046								▲/▲			
R/LU116.0056.00	.056								▲/▲			
R/LU116.0062.00	.062	.209	.402	.618	.433	.169	.803	▲/▲	▲/▲		▲/▲	
R/LU116.0078.00	.078							▲/▲	▲/▲			
R/LU116.0094.00	.094							▲/▲	▲/▲		▲/▲	
R/LU116.0125.00	.125							▲/▲	▲/▲		▲/▲	

- ▲ on stock Δ 4 weeks
- main recommendation
- alternative recommendation
- uncoated grades
- coated grades
- brazed/Cermet

Dimensions in inch
State R or L version

	P	M	K	N	S	H
MG12	○	●	●	●	●	●
TN35	●	●	●	●	●	●
T125	●	●	●	●	●	●
TF45	●	●	●	●	●	●
TH35	●	●	●	●	●	●

Carbide grades

INSERT Type

116

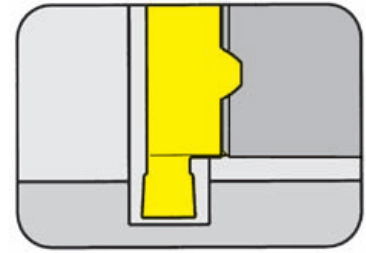

Depth of groove up to	.169"
Width of circlip Nw	.043 - .063"
Cutting edge Ø	Ds .803"

Widths for circlip grooves DIN 471/472

for use with Milling shank

Type MU116
M116

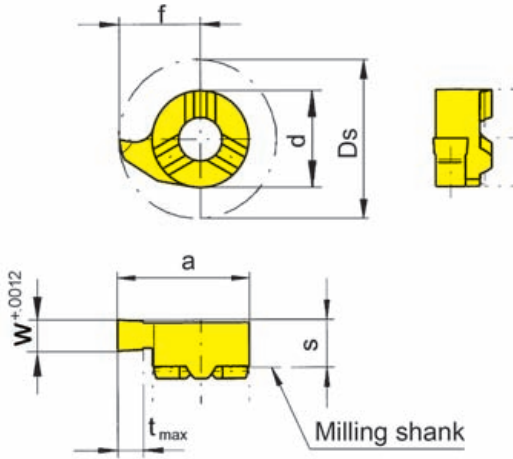

R = right hand version shown

L = left hand version

Part number	Nw	w	s	f	a	d	t _{max}	Ds	Carbide grades			
									MG12	TN35	T125	TH35
R/L116.0110.00	.043	.047							▲/▲	▲/▲		▲/▲
R/L116.0130.00	.051	.055	.209	.402	.618	.433	.169	.803	▲/▲	▲/▲		▲/▲
R/L116.0160.00	.063	.067							▲/▲	▲/▲		▲/▲
									P	o	•	•
									M	•	•	•
									K	•	•	•
									N	•	•	•
									S	•	•	•
									H			

- ▲ on stock Δ 4 weeks
- main recommendation
- o alternative recommendation
- uncoated grades
- coated grades
- brazed/Cermet

Dimensions in inch

State R or L version

Carbide grades

INSERT Type

116/U116

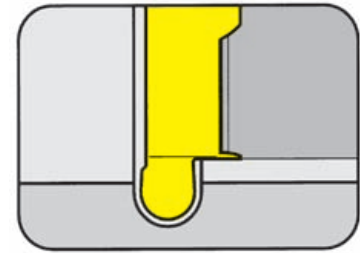

Depth of groove up to .169"
 Full radius r .031 - .079"
 Cutting edge \emptyset Ds .803"

for use with Milling shank

Type MU116
 M116

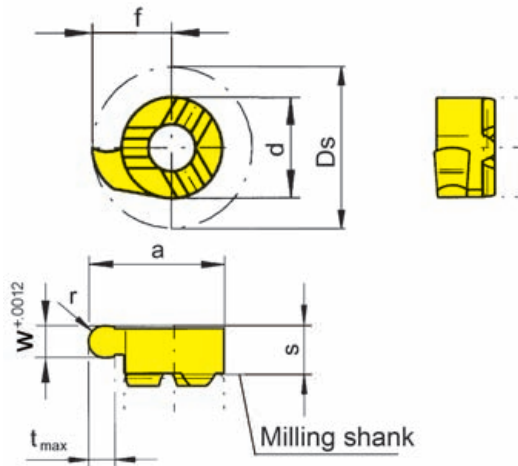

R = right hand version shown

L = left hand version

Full radius

Part number	w	r	s	f	a	d	t _{max}	Ds	Carbide grades			
									MG12	TN35	T125	TH35
R/L116.0009.18	.071	.035							▲/▲	▲/▲		▲/▲
R/L116.0011.22	.087	.043		.402	.618	.433	.169	.803	▲/▲	▲/▲		▲/▲
R/L116.0015.30	.118	.059	.209	.402	.618	.433	.169	.803	▲/▲	▲/▲		▲/▲
R/L116.0020.40	.157	.079							▲/▲	▲/▲		▲/▲
R/LU116.0031.62	.062	.031								▲/▲		
R/LU116.0039.78	.078	.039		.402	.618	.433	.169	.803		▲/▲		
R/LU116.0047.94	.094	.047	.209	.402	.618	.433	.169	.803		▲/▲		
R/LU116.0062.12	.125	.062								▲/▲		

- ▲ on stock Δ 4 weeks
- main recommendation
- alternative recommendation
- uncoated grades
- coated grades
- brazed/Cermet

	P	M	K	N	S	H
MG12	○	●	●	●	●	●
TN35	●	●	●	●	●	●
T125	●	●	●	●	●	●
TH35	●	●	●	●	●	●

Dimensions in inch

Carbide grades

State R or L version

MILLING SHANK type **MU / M313**
from bore \varnothing .866" (22.0 mm)

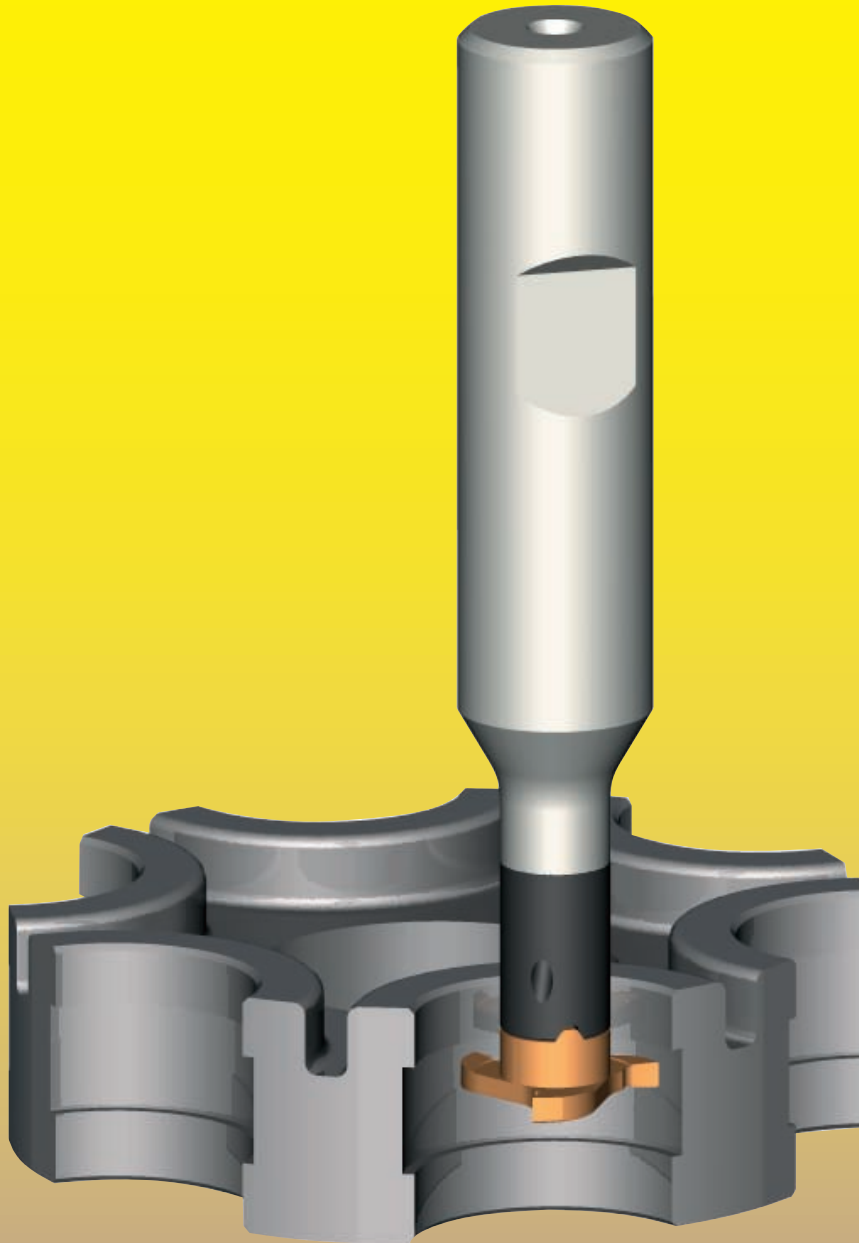

MILLING SHANK Type

MU313

with through coolant supply

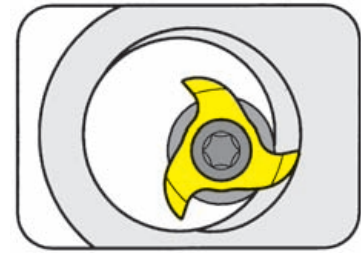
Cutting edge \emptyset

Ds .854"

Material of shank: Carbide - Giving a good vibration resistance

for use with Insert

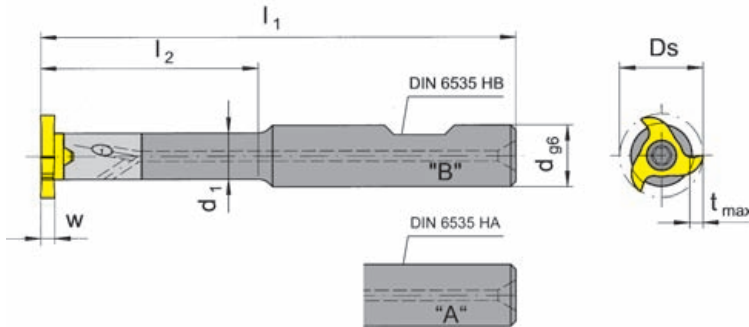

Type U313
313
313.D
613
713

Picture = right hand cutting version

Part number	l_1	l_2	d_1	d	Form
MU313.0500.01A	3.937	-	-	.500	A
MU313.0500.01B	3.937	-	-	.500	B
MU313.0500.02B	5.118	-	-	.500	B
MU313.0625.01B	3.937	1.654			
MU313.0625.02B	5.118	2.362	.472	.625	B
MU313.0625.03B	6.299	3.346			

Further sizes upon request

w, Ds, t_{max} see inserts

Dimensions in inch

Ordering note:

Milling cutter shanks with damaged seating can be repaired by HORN.

For torque specifications of the screw, please see Technical Instructions.

Spare parts

Milling shank	Screw	TORX PLUS® Wrench
MU313.0...	5.14T20P	T20PQ

MILLING SHANK Type

M313

with through coolant supply

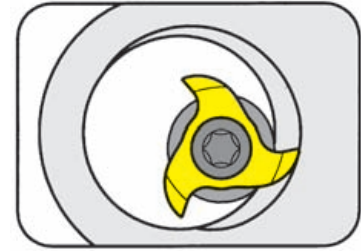

Cutting edge \varnothing

Ds 21.7 mm

Material of shank: Carbide - Giving a good vibration resistance

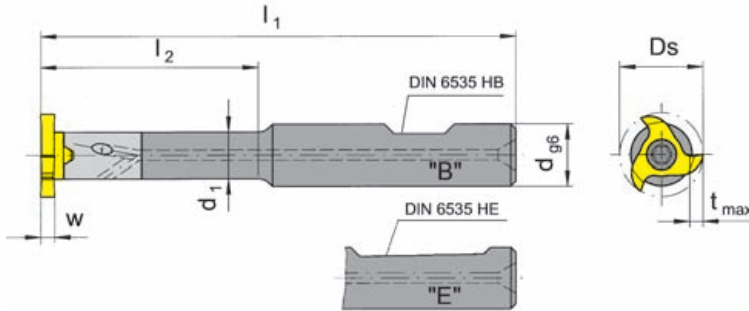

for use with Insert

Type U313
313
313.D
613
713

Picture = right hand cutting version

Part number	l_1	l_2	d_1	d	Form
M313.0012.01B	100	-	-	12	B
M313.0012.02B	130	-	-	12	B
M313.0016.01B	100	42	-	16	B
M313.0016.02B	130	60	12	16	B
M313.0016.03B	160	85	12	16	B
M313.0012.01E	100	-	-	12	E
M313.0012.02E	130	-	-	12	E
M313.0016.01E	100	42	-	16	E
M313.0016.02E	130	60	12	16	E
M313.0016.03E	160	85	12	16	E

Further sizes upon request

w, Ds, t_{max} see inserts

Dimensions in mm

Ordering note:

Milling cutter shanks with damaged seating can be repaired by HORN.

For torque specifications of the screw, please see Technical Instructions.

Spare parts

Milling shank	Screw	TORX PLUS® Wrench
M313.001...	5.14T20P	T20PQ

MILLING SHANK Type

M313

with through coolant supply

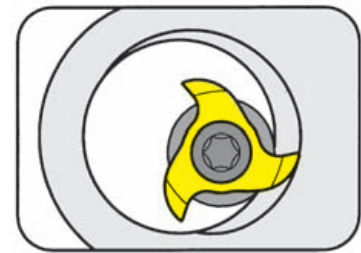
Cutting edge \varnothing

Ds 21.7 mm

Material of shank: Carbide - Giving a good vibration resistance

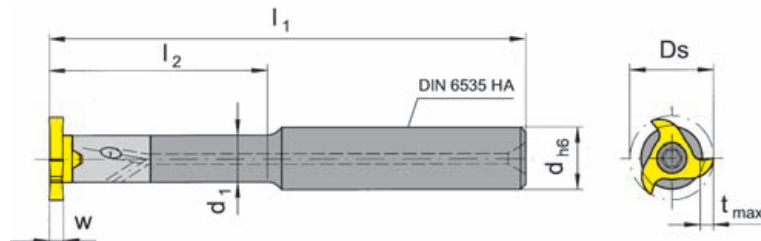

for use with Insert

Type U313
313
313.D
613
713

Picture = right hand cutting version

Part number	l_1	l_2	d_1	d
M313.0012.01A	100	-	-	12
M313.0012.02A	130	-	-	12
M313.0016.01A	100	42	12	16
M313.0016.02A	130	60	12	16
M313.0016.03A	160	85	12	16

Further sizes upon request

w, Ds, t_{max} see inserts

Dimensions in mm

Ordering note:

Milling cutter shanks with damaged seating can be repaired by HORN.

For torque specifications of the screw, please see Technical Instructions.

Spare parts

Milling shank	Screw	TORX PLUS® Wrench
M313.001...	5.14T20P	T20PQ

MILLING SHANK Type

M313.ST

no coolant supply

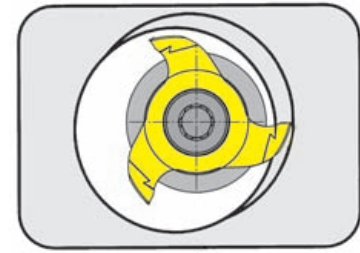

Cylindrical steel milling shank for collets Ds 21.7 mm

with cylindrical shank for CNC-lathes

for use with Insert

Type U313
313
313.D
613
713

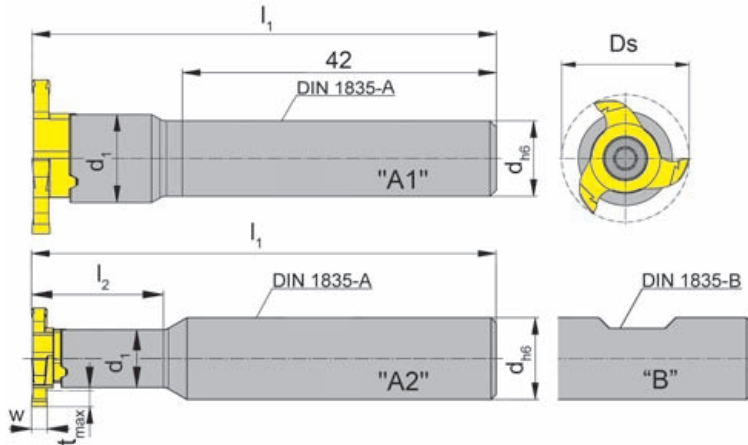

Picture = right hand cutting version

Part number	l_1	l_2	d_1	d	Form
M313.ST10.01A	60	-	11.3	10	A1
M313.ST12.01A	70	18	11.3	12	A2
M313.ST13.01A	70	26	11.3	13	
M313.ST16.01A	80	26	11.3	16	
M313.ST12.01B	70	18	11.3	12	B

Further sizes upon request

w, Ds, t_{max} see inserts

Dimensions in mm

For torque specifications of the screw, please see Technical Instructions.

Spare parts

Milling shank	Screw	TORX PLUS® Wrench
M313.ST1...	5.14T20P	T20PQ

SCREW-IN CUTTER Type

M313.M

no coolant supply

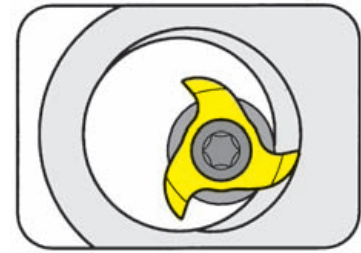

Screw-in Cutter for basic holder type WFB.20

for use with Insert

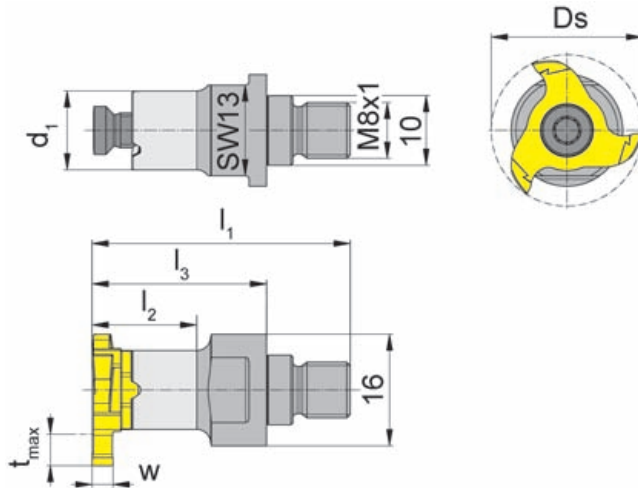
 Type U313
 313
 313.D
 613
 713

Picture = right hand cutting version

Part number	l_1	l_2	l_3	d_1
M313.M081.01	37	15	25	11.3

Further sizes upon request

w, Ds, t_{max} see inserts

Dimensions in mm

For torque specifications of the screw, please see Technical Instructions.



Spare parts

Screw-in cutter	Screw	TORX PLUS® Wrench
M313.M081.01	5.14T20P	T20PQ

BASIC HOLDER Type

WFB

Basic holder WFB.20 for screw-in cutter

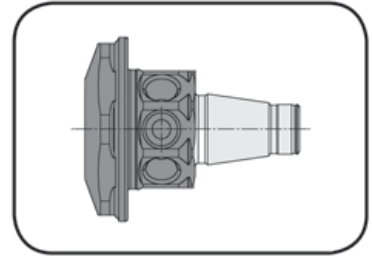

for use with Screw-in cutter

- Type
- M306.M081...
 - M308.M081...
 - M311.M081...
 - M313.M081...
 - M328.M081...
 - M332.M081...

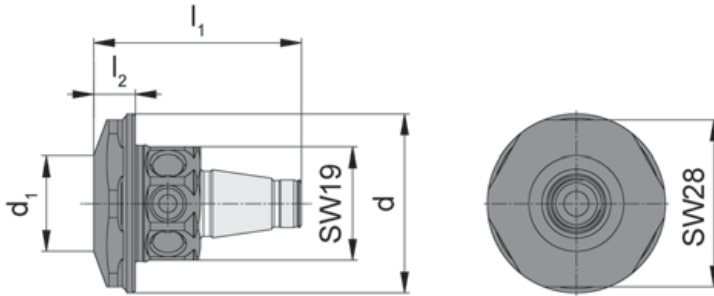

Part number	l_1	l_2	d_1	d
WFB.2012.M081.01	35	7	16	30

Further sizes upon request

Dimensions in mm



MILLING SHANK Type

M313.ER

no coolant supply

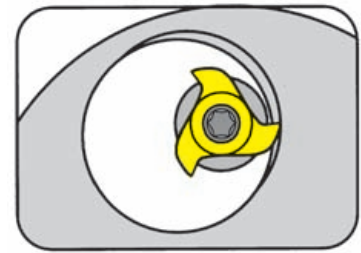

Milling shanks for collet chucks DIN6499-A (8°) Ds 21.7 mm

with ER taper for CNC-lathes

for use with Insert

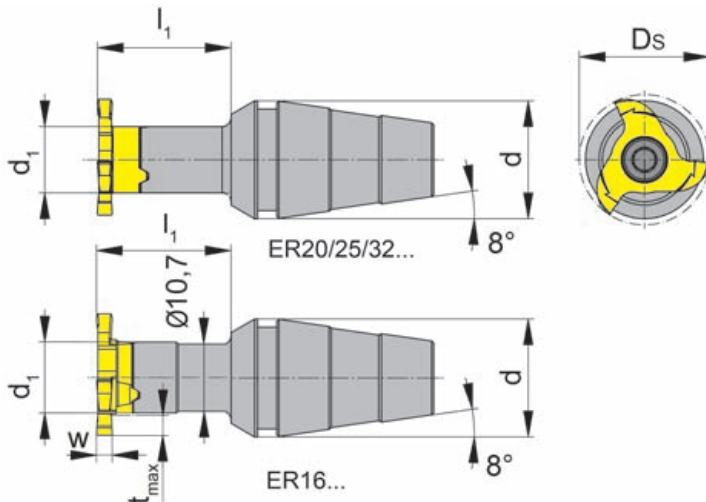
 Type U313
 313
 313.D
 613
 713

Picture = right hand cutting version

Part number	l_1	d_1	d	Clamping nut
M313.ER16.01	20	11.3	16	ER16.6499/ERM...
M313.ER20.01			20	ER20.6499/ERM...
M313.ER16.02	30	11.3	16	ER16.6499/ERM...
M313.ER20.02			20	ER20.6499/ERM...
M313.ER25.02			25	ER25.6499
M313.ER32.02			32	ER32.6499

Further sizes upon request

w, Ds, t_{max} see inserts

Dimensions in mm

For torque specifications of the screw, please see Technical Instructions.

Ordering note:

Clamping nut is not combined with milling shank - separate order required!

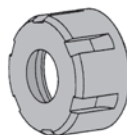
**Spare parts**

Milling shank	Screw	TORX PLUS® Wrench
M313.ER...	5.14T20P	T20PQ

INSERT Type

313/U313

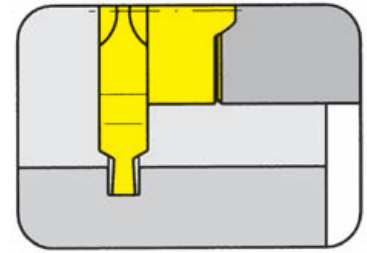

Depth of groove up to	.098"
Width of circlip Nw	.028 - .043"
Cutting edge Ø	Ds .854"

Widths for circlip grooves DIN 471/472

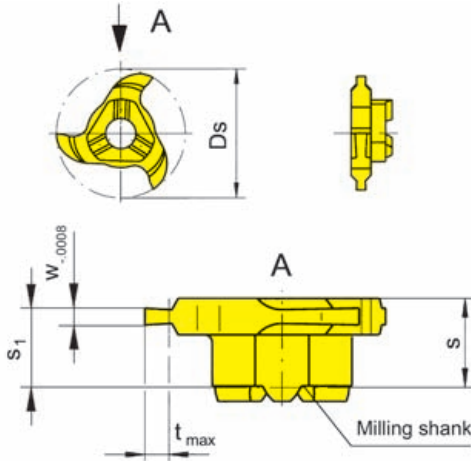

for use with Milling shank

- Type
- MU313
 - M313
 - M313.ER
 - M313.M
 - Z313

Picture = right hand cutting version

Part number	Nw	w	s ₁	s	t _{max}	Ds	MG12	TN35	AS45
*U313.0031.00		.031			.059			▲	
*U313.0039.00	-	.039	.220	.230	.075	.854		▲	
*U313.0046.00		.046			.098		Δ	▲	
313.0070.00	.028	.030			.059			▲	
313.0080.00	.031	.034			.067			▲	
313.0090.00	.035	.038	.220	.232	.075	.854	Δ	▲	
313.0100.00	.039	.042			.087			▲	
313.0110.00	.043	.048			.098			▲	

- ▲ on stock Δ 4 weeks
- main recommendation
- alternative recommendation
- uncoated grades
- coated grades
- brazed/Cermet

P	○	●
M	●	●
K	●	●
N	●	●
S	●	●
H		

Carbide grades

Dimensions in inch

* For inserts U313... the tolerance w = +.0012

INSERT Type

313

Depth of groove up to .177"
 Width of groove up to .039"
 Cutting edge \emptyset Ds .854"

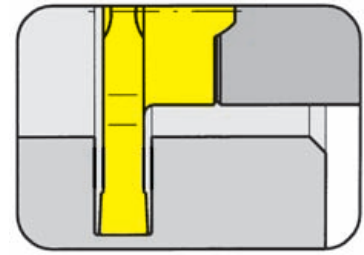

for use with Milling shank

Type MU313
 M313
 M313.ER
 M313.M
 Z313

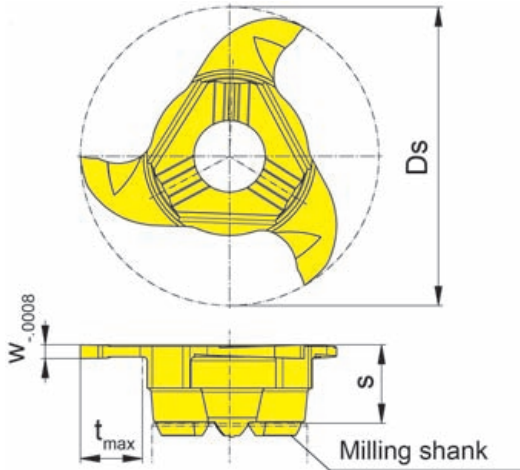

Picture = right hand cutting version

Part number	w	s	t _{max}	Ds	Carbide grades			
					MG12	TN35	TI25	AS45
313.0100.1.00	.039	.224	.177	.854		▲	▲	
▲ on stock Δ 4 weeks					P	•	•	
● main recommendation					M	•	•	
○ alternative recommendation					K	•	•	
■ uncoated grades					N	•	•	
■ coated grades					S	•	•	
■ brazed/Cermet					H			

Dimensions in inch

INSERT Type

313

Depth of groove up to .177"
 Width of circlip Nw .051 - .203"
 Cutting edge Ø Ds .854"

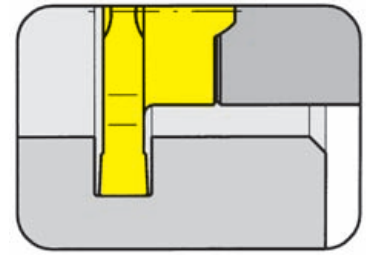

Widths for circlip grooves DIN 471/472

for use with Milling shank

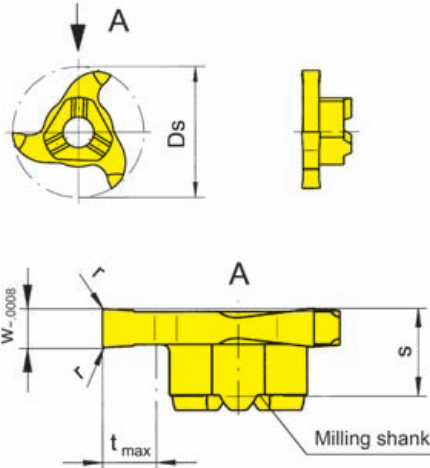

Type MU313
 M313
 M313.ER
 M313.M
 Z313

Picture = right hand cutting version

Part number	Nw	w	r	s	t _{max}	Ds	MG12	TN35	AS45
313.0130.00	.051	.056	-	.224	.177	.854	▲	▲	▲
313.0160.00	.063	.067	-	.224	.177	.854	▲	▲	▲
313.0185.00	.073	.077	-	.224	.177	.854	▲	▲	▲
313.0215.00	.085	.089	-	.224	.177	.854	▲	▲	▲
313.0265.00	.104	.109	-	.224	.177	.854	▲	▲	▲
313.0315.00	.124	.128	.008	.224	.177	.854	▲	▲	▲
313.0415.00	.163	.168	-	.224	.177	.854	▲	▲	▲
313.0515.00	.203	.207	-	.224	.177	.854	▲	▲	▲

- ▲ on stock Δ 4 weeks
- main recommendation
- alternative recommendation
- uncoated grades
- coated grades
- brazed/Cermet

P	○	●	●
M	●	●	●
K	●	●	●
N	●	●	○
S	●	●	●
H			

Carbide grades

Dimensions in inch

Inserts 313.0415.00 and 313.0515.00 only with toolholder dimension l₂ = max. 1.654"

INSERT Type

313

Depth of groove up to .177"
 Width of groove up to .236"
 Cutting edge Ø Ds .854"

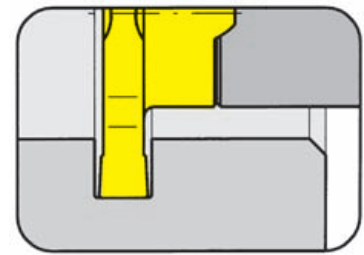

for use with Milling shank

Type MU313
 M313
 M313.ER
 M313.M
 Z313

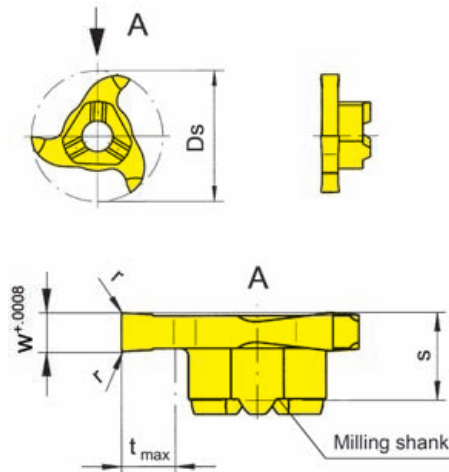

Picture = right hand cutting version

Part number	w	r	s	t _{max}	Ds	Carbide grades			
						MG12	TN35	TI25	AS45
313.0150.00	.059	-	.224	.177	.854	▲	▲		▲
313.0150.01	.059	.004	.224			▲	▲		▲
313.0200.00	.079	.008	.224			▲	▲		▲
313.0250.00	.098	.008	.224			▲	▲	▲	▲
313.0300.00	.118	.008	.224			▲	▲		▲
313.0350.00	.138	.008	.224			△	▲		▲
313.0400.00	.157	.008	.224			▲	▲		▲
313.0500.00	.197	.008	.224			▲	▲		▲
313.0600.00	.236	.008	.272			▲	▲		▲
						P	o	•	•
						M	•	•	•
						K	•	•	•
						N	•	•	o
						S	•	•	•
						H			

- ▲ on stock △ 4 weeks
- main recommendation
- o alternative recommendation
- uncoated grades
- coated grades
- brazed/Cermet

Dimensions in inch

Carbide grades

Inserts 313.0500.00 and 313.0600.00 only with toolholder dimension l₂ = max 1.654"

INSERT Type

U313

Depth of groove up to .177"
 Width of groove up to .250"
 Cutting edge Ø Ds .854"

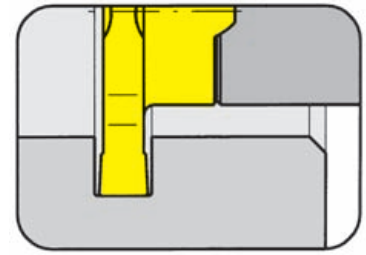

for use with Milling shank

Type MU313
 M313
 M313.ER
 M313.M
 Z313

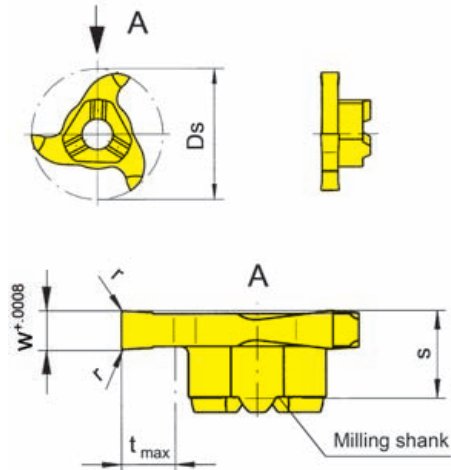

Picture = right hand cutting version

Part number	w	r	s	t _{max}	Ds	Carbide grades			
						MG12	TN35	AS45	TF45
U313.0056.00	.056	-	.224	.177	.854	Δ	▲		
U313.0062.00	.062	-	.224	.177	.854	Δ	▲		
U313.0062.08	.062		.224				▲		
U313.0078.08	.078		.224				▲		
U313.0094.08	.094		.224				▲		▲
U313.0125.08	.125	.008	.224	.177	.854	▲	▲		
U313.0157.08	.157	.008	.224	.177	.854	Δ	▲		
U313.0172.08	.172		.224				Δ		
U313.0187.08	.187		.224				Δ	▲	
U313.0250.08	.250		.272				▲	▲	

- ▲ on stock Δ 4 weeks
- main recommendation
- alternative recommendation
- uncoated grades
- coated grades
- brazed/Cermet

	P	M	K	N	S	H
MG12	○	●	●	●	●	●
TN35	●	●	●	●	●	●
AS45	●	●	●	●	●	●
TF45	●	●	●	●	●	●

Dimensions in inch

Carbide grades

Inserts **U313.0187.08** and **U313.0250.08** only with toolholder dimension $l_2 = \text{max. } 1.654''$

INSERT Type

313

machining of aluminium

Depth of groove up to .177"
 Width of groove up to .157"
 Cutting edge \varnothing Ds .854"

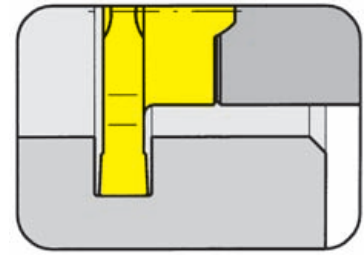

for use with Milling shank

Type MU313
 M313
 M313.ER
 M313.M
 Z313

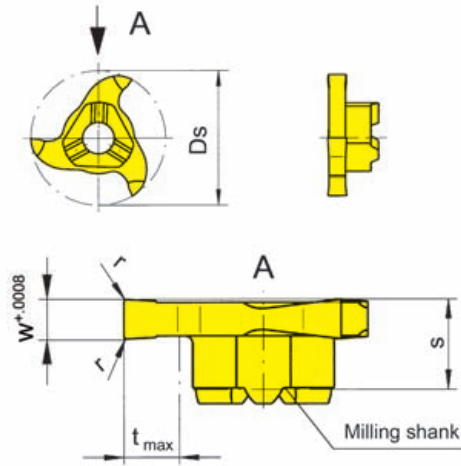

Picture = right hand cutting version

Part number	w	r	s	t _{max}	Ds	Carbide grades	
						MG12	TI25
313.0150.40	.059	-					▲
313.0200.40	.079	.008					▲
313.0250.40	.098	.008	.224	.177	.854		▲
313.0300.40	.118	.008					▲
313.0400.40	.157	.008					▲
						P	•
						M	•
						K	•
						N	•
						S	•
						H	•

- ▲ on stock Δ 4 weeks
- main recommendation
- o alternative recommendation
- uncoated grades
- coated grades
- brazed/Cermet

Dimensions in inch

Carbide grades

INSERT Type

313

machining of aluminium

Depth of groove up to	.177"
Width of circlip Nw	.051 - .203"
Cutting edge Ø	Ds .854"

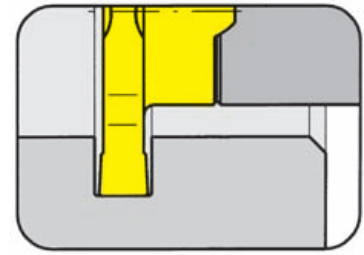

Widths for circlip grooves DIN 471/472

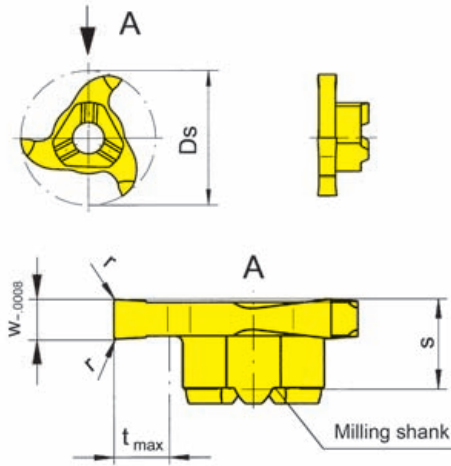

for use with Milling shank

- Type MU313
M313
M313.ER
M313.M
Z313

Picture = right hand cutting version

Part number	Nw	w	r	s	t _{max}	Ds	Carbide grades	
							MG12	TI25
313.0130.40	.051	.056	-	.224	.177	.854		▲
313.0160.40	.063	.067	-	.224	.177	.854		▲
313.0185.40	.073	.077	-	.224	.177	.854		▲
313.0215.40	.085	.089	-	.224	.177	.854		▲
313.0265.40	.104	.109	.008	.224	.177	.854		▲
313.0315.40	.124	.128	.008	.224	.177	.854		▲
313.0415.40	.163	.168	.008	.224	.177	.854	▲	▲
313.0515.40	.203	.207	.008	.224	.177	.854	▲	▲

- ▲ on stock Δ 4 weeks
- main recommendation
- alternative recommendation
- uncoated grades
- coated grades
- brazed/Cermet

Dimensions in inch

Carbide grades

Inserts 313.0415.40 and 313.0515.40 only with toolholder dimension l₂ = max. 1.654"

INSERT Type

313

Depth of groove up to .098"
 Width of circlip Nw .043 - .163"
 Cutting edge Ø Ds .854"

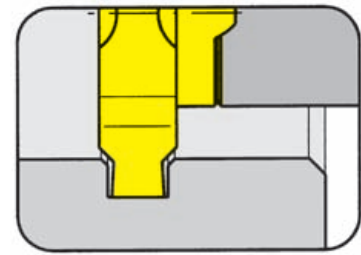

Widths for circlip grooves DIN 471/472

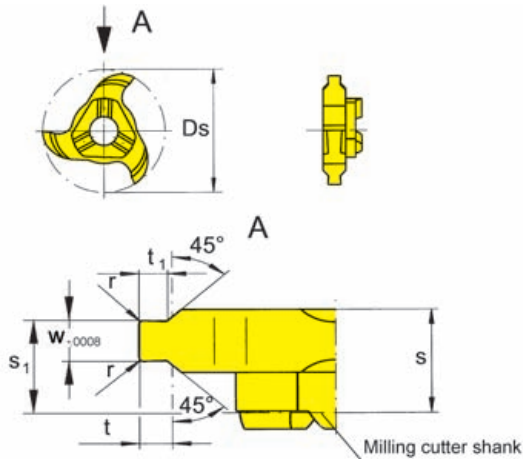

for use with Milling shank

- Type MU313
 M313
 M313.ER
 M313.M
 Z313

with chamfering

Picture = right hand cutting version

Part number	Nw	w	r	t ₁	s ₁	s	t _{max}	Ds	Carbide grades				
									MG12	TN35	TA45	AS45	
313.1105.30	.043	.048		.019	.200		.020			▲			
313.1307.30	.051	.056		.026	.204		.028			▲			
313.1308.30	.051	.056	-	.032	.204	.232	.033	.854		▲			
313.1609.35	.063	.067		.032	.200		.033			▲			
313.1610.35	.063	.067		.037	.200		.039			▲			
313.1812.35	.073	.077		.048	.204		.049			▲			
313.2115.35	.085	.089		.057	.210		.059			▲	▲		
313.2616.45	.104	.109		.057	.200		.059			▲			Δ
313.2617.45	.104	.109	.008	.067	.200	.232	.069	.854		▲			Δ
313.3118.45	.124	.128		.067	.210		.069			▲			Δ
313.4120.55	.163	.168		.077	.210		.079			▲			Δ
313.4125.55	.163	.168		.096	.210		.098			▲			Δ

- ▲ on stock Δ 4 weeks
- main recommendation
- alternative recommendation
- uncoated grades
- coated grades
- brazed/Cermet

	P	M	K	N	S	H
MG12	●	●	●	●	●	●
TN35	●	●	●	●	●	●
TA45	●	●	●	●	●	●
AS45	●	●	●	○	●	●

Dimensions in inch

Carbide grades

Inserts 313.4120.55 and 313.4125.55 only with toolholder dimension l₂ = max. 1.654"

INSERT Type

313/U313

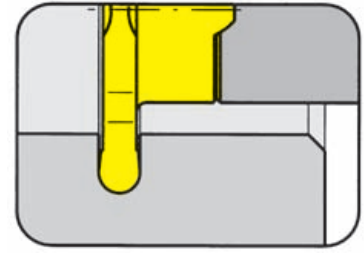

Depth of groove up to .177"
 Full radius r .020 - .125"
 Cutting edge \emptyset Ds .854"

for use with Milling shank

Type MU313
 M313
 M313.ER
 M313.M
 Z313

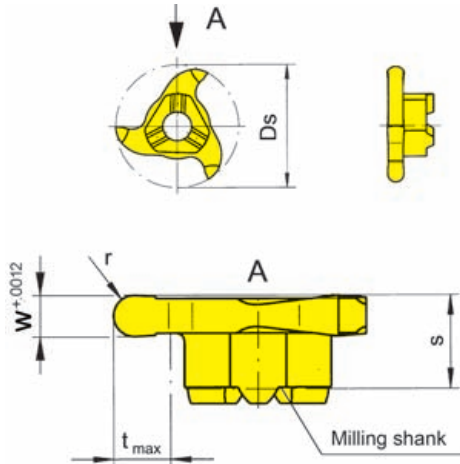

Picture = right hand cutting version

Full radius

Part number	w	r	s	t _{max}	Ds	Carbide grades				
						MG12	TN35	TI25	AS45	TF45
313.0005.10	.039	.020					▲			
313.0010.20	.079	.039					▲		▲	
313.0014.28	.110	.055	.224	.177	.854		▲		▲	
313.0015.30	.118	.059					▲		▲	
313.0020.40	.157	.079					▲		▲	
313.0025.50	.197	.098					▲		▲	
U313.0031.62	.062	.031					▲			▲
U313.0047.94	.094	.047					▲	Δ		
U313.0062.125	.125	.062	.224	.177	.854		▲			Δ
U313.0078.156	.156	.078					▲			
U313.0094.188	.188	.094					▲			Δ
U313.0125.250	.250	.125	.272	.177	.854		▲			
▲ on stock Δ 4 weeks ● main recommendation ○ alternative recommendation ■ uncoated grades ■ coated grades ■ brazed/Cermet						P	●	●	●	●
						M	●	●	●	●
						K	●	●	●	●
						N	●	●	○	●
						S	●	●	●	●
						H				

Dimensions in inch

Carbide grades

Inserts 313.0025.50, U313.0094.188 and U313.0125.250 only with toolholder dimension l₂ = max 1.654"

INSERT Type

L313

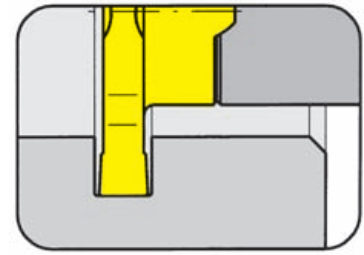

Depth of groove up to .177"
 Width of circlip Nw .051 - .203"
 Cutting edge Ø Ds .854"

Widths for circlip grooves DIN 471/472

for use with Milling shank

Type MU313
 M313
 M313.ER
 M313.M

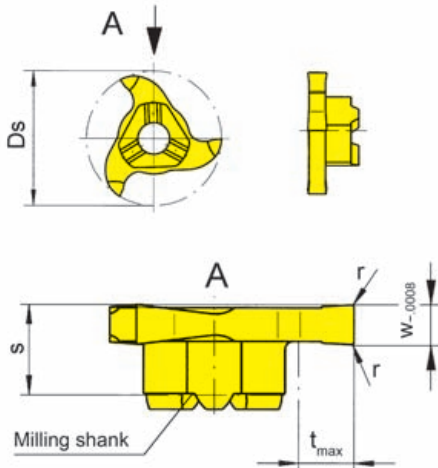

L = left hand version shown

Part number	Nw	w	r	s	t _{max}	Ds	Carbide grades			
							MG12	TN35	T125	AS45
L313.0130.00	.051	.056	-						Δ	
L313.0160.00	.063	.067	-						Δ	
L313.0185.00	.073	.077	.008						Δ	
L313.0215.00	.085	.089	.008	.224	.177	.854	Δ		Δ	
L313.0265.00	.104	.109	.008						Δ	
L313.0315.00	.124	.128	.008						Δ	
L313.0415.00	.163	.168	.008						Δ	
L313.0515.00	.203	.207	.008						Δ	
▲ on stock Δ 4 weeks ● main recommendation ○ alternative recommendation ■ uncoated grades ■ coated grades ■ brazed/Cermet							P	○	●	●
							M	●	●	●
							K	●	●	●
							N	●	●	○
							S	●	●	●
							H			

Dimensions in inch

Carbide grades

Note:

Inserts L313.0415.00 and L313.0515.00 only with toolholder dimension l₂ = max 1.654"

INSERT Type

L313

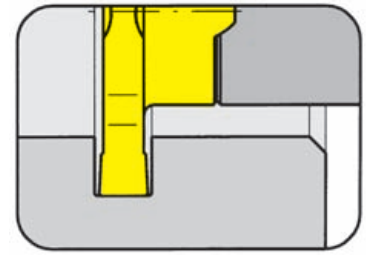

Depth of groove up to .177"
 Width of groove up to .236"
 Cutting edge Ø Ds .854"

for use with Milling shank

Type MU313
 M313
 M313.ER
 M313.M

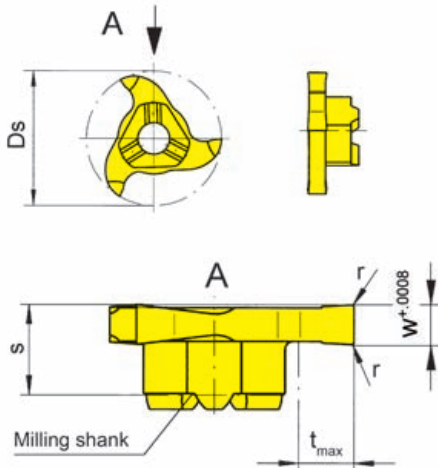

L = left hand version shown

Part number	w	r	s	t _{max}	Ds	Carbide grades			
						MG12	TN35	T125	AS45
L313.0150.00	.059	-							Δ
L313.0150.01	.059	.004							Δ
L313.0200.00	.079	.008							Δ
L313.0250.00	.098	.008							Δ
L313.0300.00	.118	.008	.224	.177	.854				Δ
L313.0350.00	.138	.008				Δ		Δ	Δ
L313.0400.00	.157	.008						Δ	Δ
L313.0500.00	.197	.008						Δ	Δ
L313.0600.00	.236	.008	.272	.177	.854			Δ	Δ

- ▲ on stock Δ 4 weeks
- main recommendation
- alternative recommendation
- uncoated grades
- coated grades
- brazed/Cermet

Dimensions in inch

Carbide grades

Note:

Inserts **L313.0500.00** and **L313.0600.00** only with toolholder dimension $l_2 = \max 1.654"$

INSERT Type

613

Depth of groove up to	.177"
Width of groove	.039"
Cutting edge Ø	Ds .854"

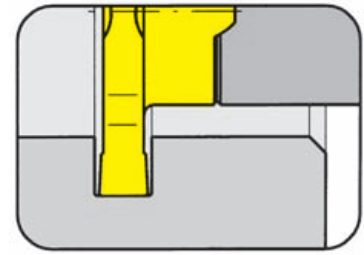

for use with Milling shank

Type MU313
M313
M313.ER
M313.M

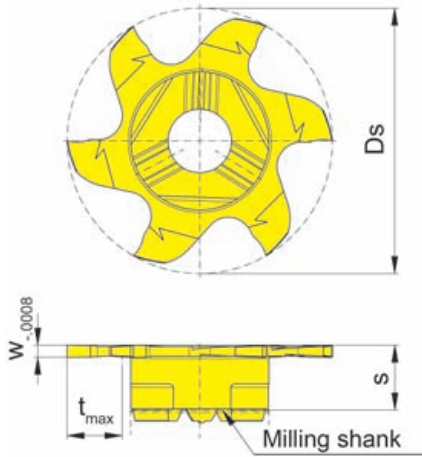

Picture = right hand cutting version

Part number	w	s	t _{max}	Ds	Carbide grades				
					MG12	TN35	TI25	TA45	AS45
613.0100.1.00	.039	.209	.177	.854			▲		
▲ on stock Δ 4 weeks					P		•		
● main recommendation					M		•		
○ alternative recommendation					K		•		
■ uncoated grades					N		•		
■ coated grades					S		•		
■ brazed/Cermet					H				

Dimensions in inch

INSERT Type

613

Depth of groove up to .177"
 Width of groove up to .157"
 Cutting edge Ø Ds .854"

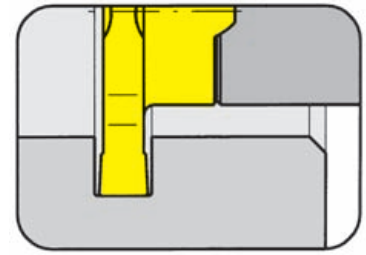

for use with Milling shank

Type MU313
 M313
 M313.ER
 M313.M

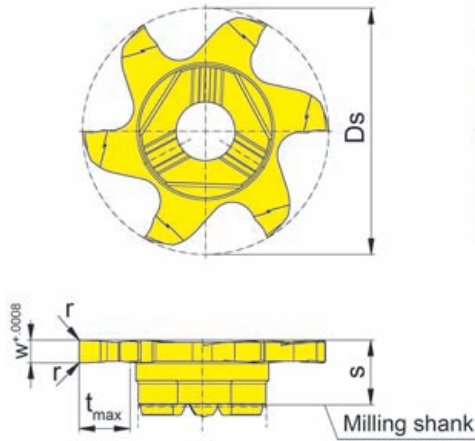

Picture = right hand cutting version

Part number	w	r	s	t _{max}	Ds	Carbide grades		
						MG12	T125	AS45
613.0150.00	.059	-					▲	▲
613.0200.00	.079	.008					▲	▲
613.0250.00	.098	.008	.224	.177	.854		▲	▲
613.0300.00	.118	.008					▲	▲
613.0400.00	.157	.008					▲	▲
						P	●	●
						M	●	●
						K	●	●
						N	●	○
						S	●	●
						H		

- ▲ on stock Δ 4 weeks
- main recommendation
- alternative recommendation
- uncoated grades
- coated grades
- brazed/Cermet

Dimensions in inch

Note:
 Insert 613.0400.00 only with toolholder dimension l₂ = max 1.654"

INSERT Type

713

Depth of groove up to .177"
 Width of groove .039 - .118"
 Cutting edge Ø Ds .854"

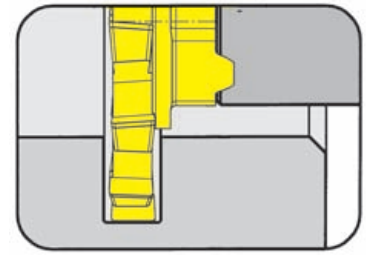

for use with Milling shank

Type MU313
 M313
 M313.ER
 M313.M

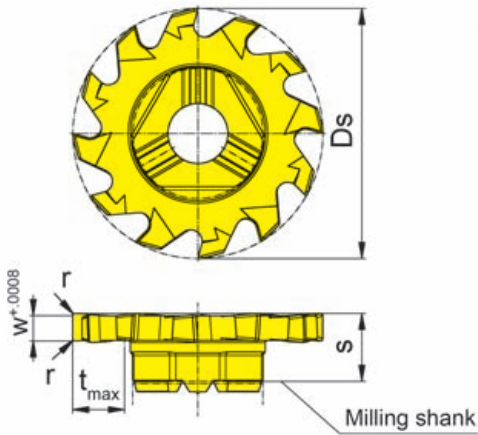

Picture = right hand cutting version

Part number	w	r	s	t _{max}	Ds	Z	Carbide grades				
							MG12	TN35	TI25	TA45	AS45
713.0100.00	.039	-							▲		
713.0150.00	.059	-							▲		
713.0200.00	.079	.008	.232	.177	.854	12			▲		
713.0250.00	.098	.008							▲		
713.0300.00	.118	.008							▲		
							P		•		
							M		•		
							K		•		
							N		•		
							S		•		
							H				

- ▲ on stock Δ 4 weeks
- main recommendation
- o alternative recommendation
- uncoated grades
- coated grades
- brazed/Cermet

Dimensions in inch

Carbide grades

MILLING SHANK type **Z313**

Double Groove Milling
with inserts **type 313 and 313.D**
from bore \varnothing .866" (22.0 mm)

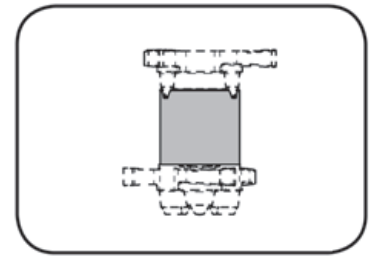

ADAPTOR Type

Z313

Adaptor for inserts type 313.D...

Material of shank: Steel

for use with Insert

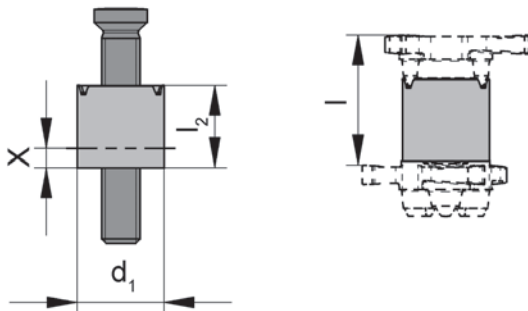
 Type U313
 313
 313.D...

Part number	l	l ₂	X	d ₁
Z.313.0011.057	9.9	3,7 - 5,7	0 - 2,0	11.3
Z.313.0011.082	11.9	5,7 - 8,2	0 - 2,5	
Z.313.0011.107	14.4	8,2 - 10,7	0 - 2,5	

Further sizes upon request

Dimensions in mm

For torque specifications of the screw, please see Technical Instructions.

Spare parts

Adaptor	Screw	TORX PLUS® Wrench
Z.313.0011.057	5.26T20P	T20PQ
Z.313.0011.082	5.28T20P	T20PQ
Z.313.0011.107	5.30T20P	T20PQ

INSERT Type

313.D

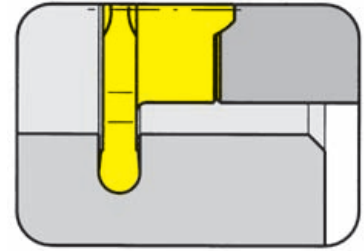

Depth of groove up to	.177"
Full radius	r .020 - .059"
Cutting edge \varnothing	Ds .854"

for use with Milling shank

Type MU313
M313
Z313

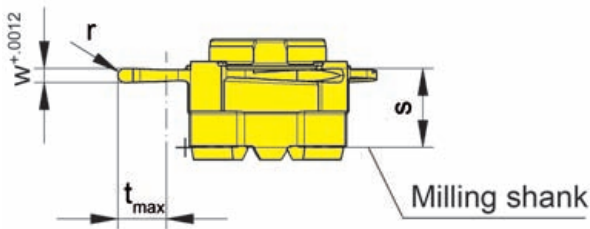
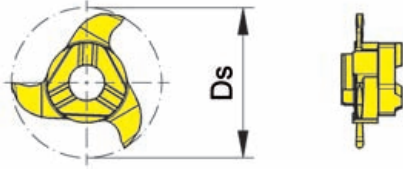

Picture = right hand cutting version

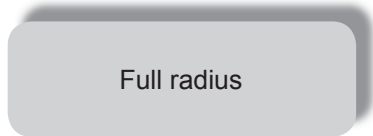

Part number	w	r	s	t _{max}	Ds	MG12	TN35	TI25	AS45
313.D.0005.10	.039	.020					▲		▲
313.D.0010.20	.079	.039					▲		▲
313.D.0014.28	.110	.055	.224	.177	.854		▲		▲
313.D.0015.30	.118	.059					▲		▲
						P	•		•
						M	•		•
						K	•		•
						N	•		○
						S	•		•
						H			

- ▲ on stock Δ 4 weeks
- main recommendation
- alternative recommendation
- uncoated grades
- coated grades
- brazed/Cermet

Dimensions in inch

Carbide grades

INSERT Type

313.D

Depth of groove up to	.177"
Width of groove	.059 - .118"
Cutting edge Ø	Ds .854"

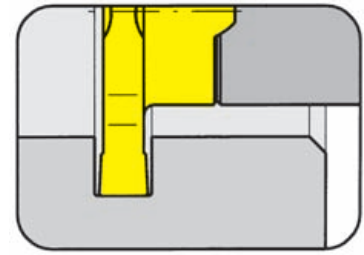

for use with Milling shank

Type MU313
M313
Z313

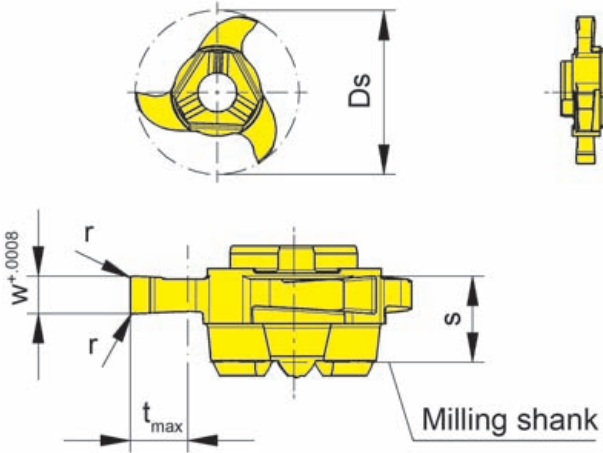

Picture = right hand cutting version

Part number	w	r	s	t _{max}	Ds	Carbide grades			
						MG12	TN35	T125	AS45
313.D.0150.00	.059	-					▲		▲
313.D.0150.01	.059	.004					▲		▲
313.D.0200.00	.079	.008	.224	.177	.854		▲		▲
313.D.0250.00	.098	.008					▲		▲
313.D.0300.00	.118	.008					▲		▲
						P	•		•
						M	•		•
						K	•		•
						N	•		○
						S	•		•
						H			

- ▲ on stock Δ 4 weeks
- main recommendation
- alternative recommendation
- uncoated grades
- coated grades
- brazed/Cermet

Dimensions in inch

Carbide grades

INSERT Type

313.D

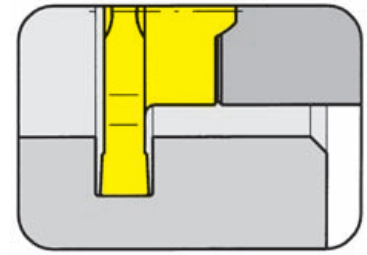

Depth of groove up to	.177"
Width of circlip Nw	.051 - .124"
Cutting edge Ø	Ds .854"

Widths for circlip grooves DIN 471/472

for use with Milling shank

Type MU313
M313
Z313

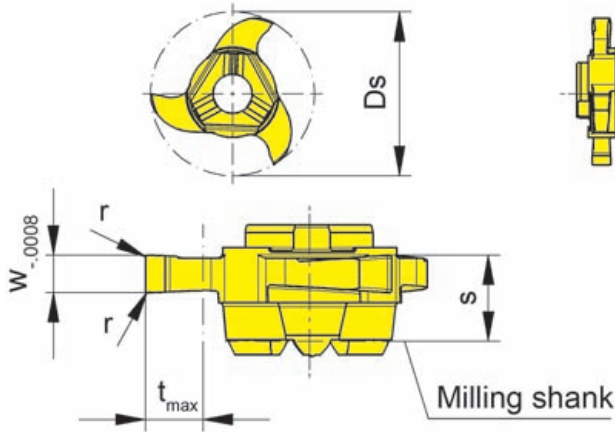

Picture = right hand cutting version

Part number	Nw	w	r	s	t _{max}	Ds	Carbide grades			
							MG12	TN35	T125	AS45
313.D.0130.00	.051	.056	-					▲	▲	
313.D.0160.00	.063	.067	-					▲	▲	
313.D.0185.00	.073	.077	.008	.224	.177	.854		▲	▲	
313.D.0215.00	.085	.089	.008					▲	▲	
313.D.0265.00	.104	.109	.008					▲	▲	
313.D.0315.00	.124	.128	.008					▲	▲	
▲ on stock Δ 4 weeks ● main recommendation ○ alternative recommendation ■ uncoated grades ■ coated grades ■ brazed/Cermet							P	●	●	
							M	●	●	
							K	●	●	
							N	●	○	
							S	●	●	
							H			

Dimensions in inch

Carbide grades

If required, the connecting pieces Z.313.0011... can be reduced by the dimension "X" through hard turning or grinding. The screw will not change.



MILLING SHANK type **MU / M328**
from bore \varnothing 1.102" (28.0 mm)

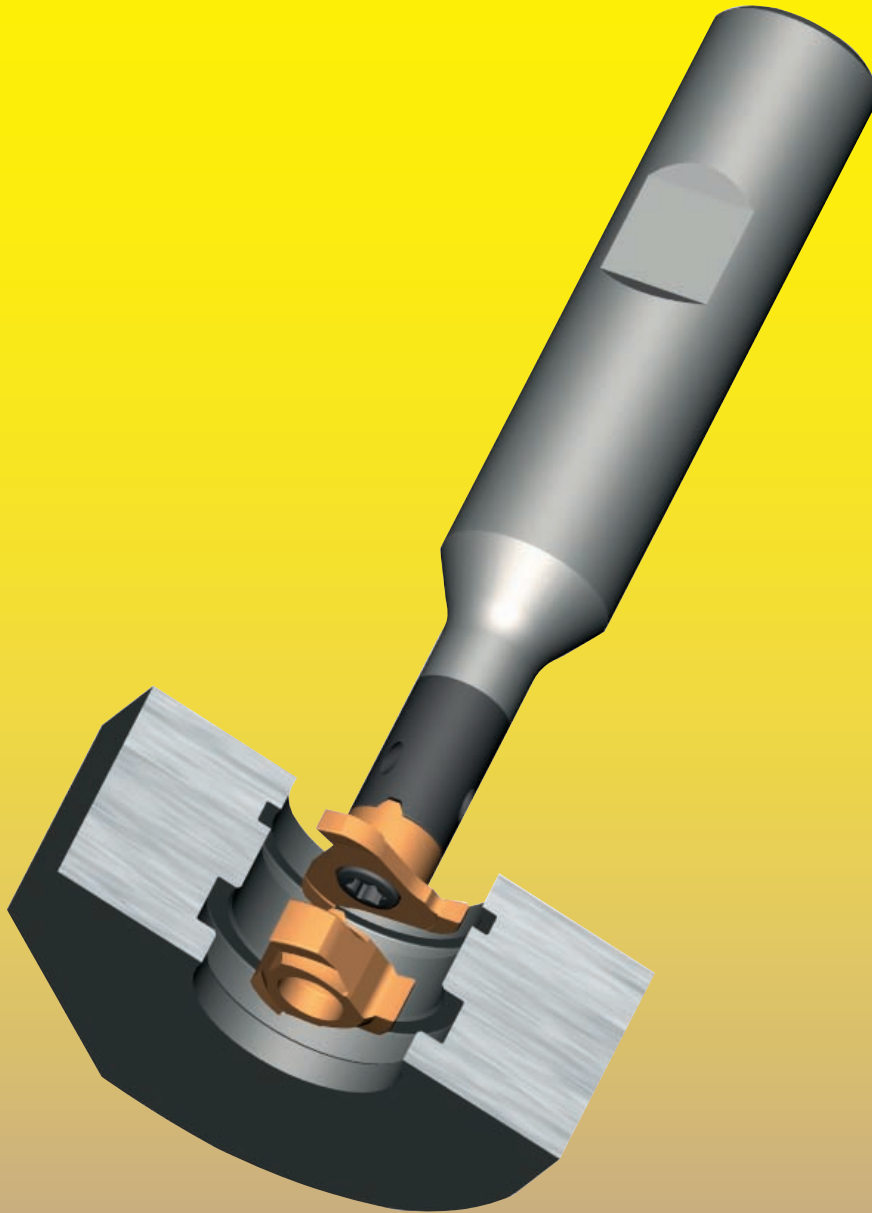

MILLING SHANK Type

MU328

with through coolant supply

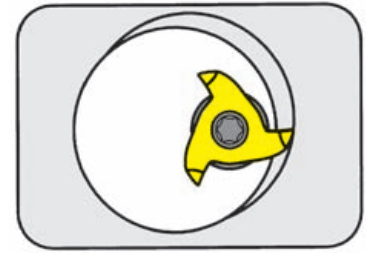
Cutting edge \varnothing

Ds .976 / 1.091 "

Material of shank: Carbide - Giving a good vibration resistance

for use with Insert

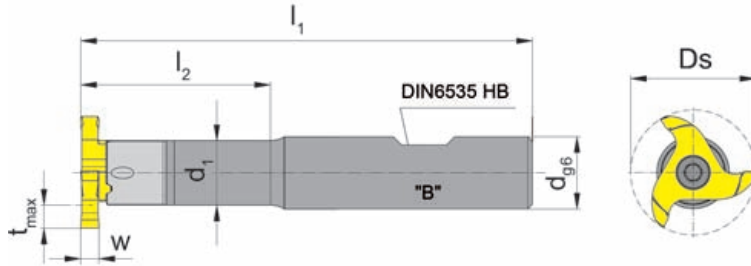

Type U325
U328
325
328
628

Picture = right hand cutting version

Part number	l_1	l_2	d_1	d
MU328.0500.01B	3.937	.815	.563	.500
MU328.0500.02B	5.118	.815	.563	.500
MU328.0625.01B	3.937	1.654	.563	.625
MU328.0625.02B	5.118	2.362	.563	.625
MU328.0625.03B	6.299	3.346	.563	.625
MU328.0750.03B	6.299	3.346	.563	.750

Further sizes upon request

w, Ds, t_{max} see inserts

Dimensions in inch

Ordering note:

Milling cutter shanks with damaged seating can be repaired by HORN.

For torque specifications of the screw, please see Technical Instructions.

Spare parts

Milling shank	Screw	TORX PLUS® Wrench
MU328.0...	5.17T20P	T20PQ

MILLING SHANK Type

M328

with through coolant supply

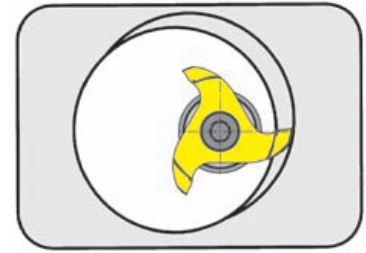

Cutting edge \varnothing

Ds 24.8/27.7 mm

Material of shank: Carbide - Giving a good vibration resistance

for use with Insert

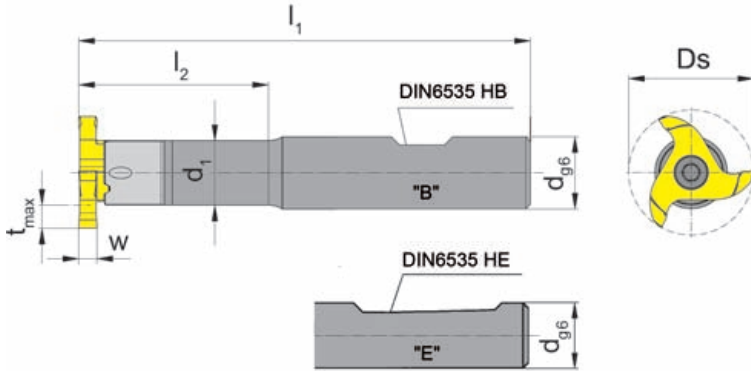

Type U325
U328
325
328
628

Picture = right hand cutting version

Part number	l_1	l_2	d_1	d	Form
M328.0016.01B	100	42	14.3	16	B
M328.0016.02B	130	60		16	
M328.0016.03B	160	85		16	
M328.0020.01B	100	42		20	
M328.0020.02B	130	60		20	
M328.0020.03B	160	85		20	
M328.0016.01E	100	42	14.3	16	E
M328.0016.02E	130	60		16	
M328.0016.03E	160	85		16	
M328.0020.01E	100	42		20	
M328.0020.02E	130	60		20	
M328.0020.03E	160	85		20	

Further sizes upon request

w, Ds, t_{max} see inserts

Dimensions in mm

Ordering note:

Milling cutter shanks with damaged seating can be repaired by HORN.

For torque specifications of the screw, please see Technical Instructions.

Spare parts

Milling shank	Screw	TORX PLUS® Wrench
M328.00...	5.14T20P	T20PQ

MILLING SHANK Type

M328

with through coolant supply

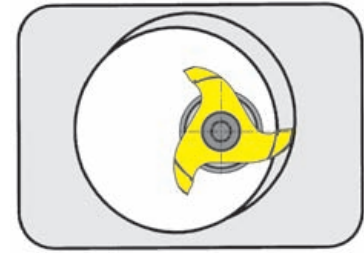
Cutting edge \varnothing

Ds 24.8/27.7 mm

Material of shank: Carbide - Giving a good vibration resistance

for use with Insert

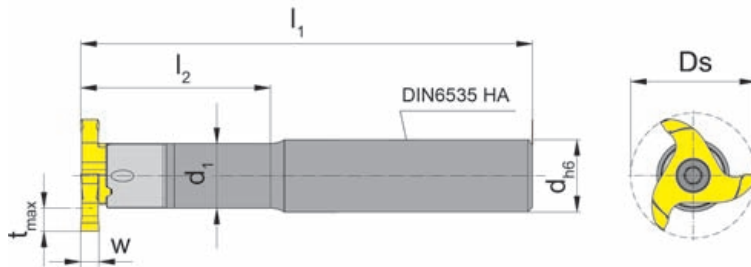
 Type U325
 U328
 325
 328
 628

Picture = right hand cutting version

Part number	l_1	l_2	d_1	d
M328.0016.01A	100	42		
M328.0016.02A	130	60	14.3	16
M328.0016.03A	160	85		
M328.0020.01A	100	42		
M328.0020.02A	130	60	14.3	20
M328.0020.03A	160	85		

Further sizes upon request

w, Ds, t_{max} see inserts

Dimensions in mm

Ordering note:

Milling cutter shanks with damaged seating can be repaired by HORN.

For torque specifications of the screw, please see Technical Instructions.

Spare parts

Milling shank	Screw	TORX PLUS® Wrench
M328.00...	5.14T20P	T20PQ

MILLING SHANK Type

M328

no coolant supply

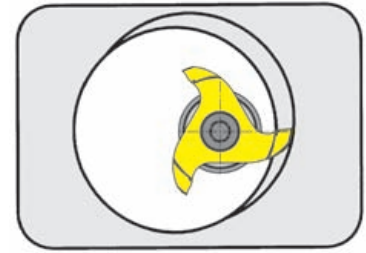

Cutting edge Ø

Ds 28.0 mm

Material of shank: Carbide - Giving a good vibration resistance

for use with Insert

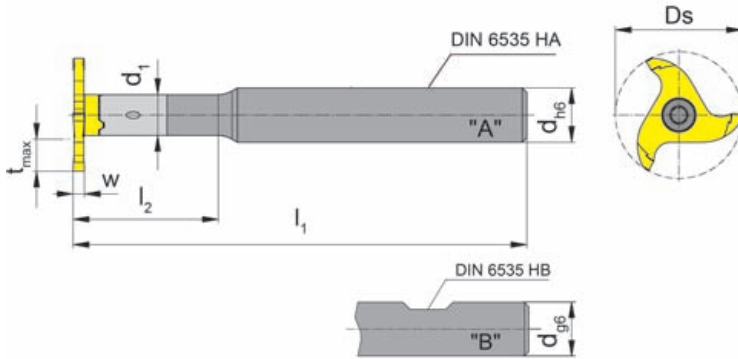

Type U325
U328
325
328
628

for inserts with increased milling depth

Picture = right hand cutting version

Part number	l_1	l_2	d_1	d	Form
M328.0909.01A*	120	-	-	9	A
M328.0912.01A	100	32	9	12	A
M328.0912.01B	100	32	-	12	B

Further sizes upon request

w, Ds, t_{max} see inserts

Dimensions in mm

* = no through coolant supply!

Ordering note:

Milling cutter shanks with damaged seating can be repaired by HORN.

For torque specifications of the screw, please see Technical Instructions.

Spare parts

Milling shank	Screw	TORX PLUS® Wrench
M328.09...	5.14T20P	T20PQ

MILLING SHANK Type

M328.ST

no coolant supply

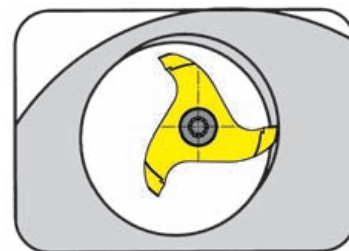

Cylindrical steel milling shank for collets Ds 24.8/27.7 mm

with cylindrical shank for CNC-lathes

for use with Insert

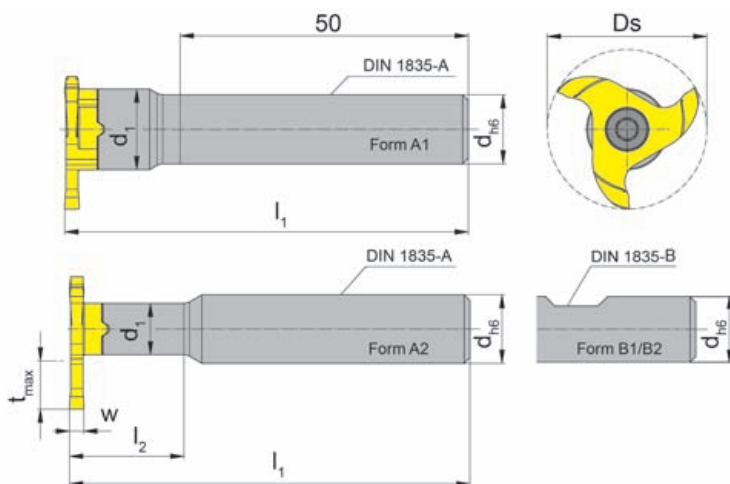
 Type U325
 U328
 325
 328
 628

Picture = right hand cutting version

Part number	l_1	l_2	d_1	d	Form
M328.ST12.01A M328.ST13.01A	70	-	14	12 13	A1
M328.ST12.2.01A M328.ST16.01A M328.ST20.01A	70 90 100	20 36 36	9 14 14	12 16 20	A2
M328.ST12.01B M328.ST12.2.01B	70	- 20	14 9	12	B1 B2

Further sizes upon request

w, Ds, t_{max} see inserts

Dimensions in mm

For torque specifications of the screw, please see Technical Instructions.

Spare parts

Milling shank	Screw	TORX PLUS® Wrench
M328.ST...	5.14T20P	T20PQ

SCREW-IN CUTTER Type

M328.M

no coolant supply

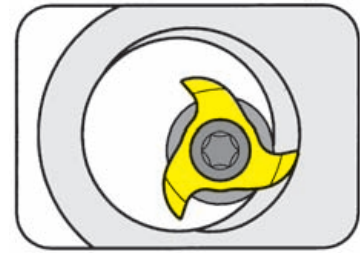

Screw-in Cutter for basic holder type WFB.20

for use with Insert

- Type U325
- U328
- 325
- 328
- 628

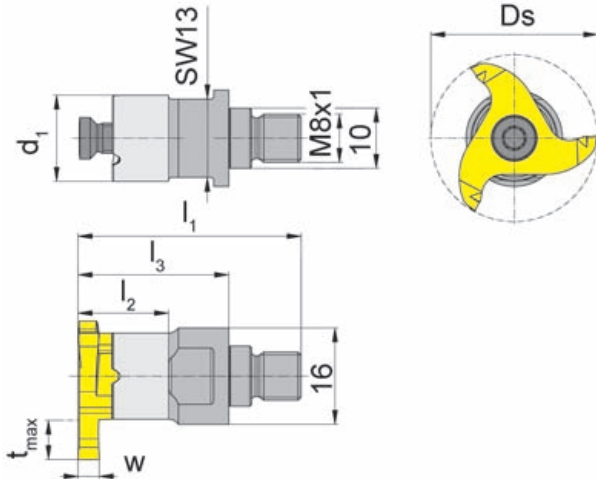

Picture = right hand cutting version

Part number	l_1	l_2	l_3	d_1
M328.M081.01	37	15	25	14.3

Further sizes upon request

w, Ds, t_{max} see inserts

Dimensions in mm

For torque specifications of the screw, please see Technical Instructions.



Spare parts

Screw-in cutter	Screw	TORX PLUS® Wrench
M328.M081.01	5.14T20P	T20PQ

BASIC HOLDER Type

WFB

Basic shank WFB.20 for screw-in cutter

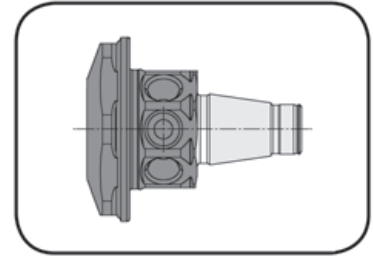

for use with Screw-in cutter

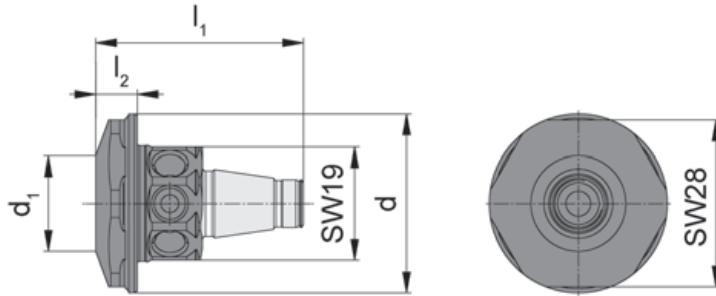

Type M306.M081...
M308.M081...
M311.M081...
M313.M081...
M328.M081...
M332.M081...

Part number	l_1	l_2	d_1	d
WFB.2012.M081.01	35	7	16	30

Further sizes upon request

Dimensions in mm



MILLING SHANK Type

M328.ER

no coolant supply

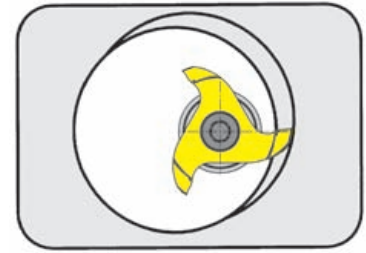

Milling shanks for collet chucks DIN6499-A (8°) Ds
24.8/27.7 mm

with ER taper for CNC-lathes

for use with Insert

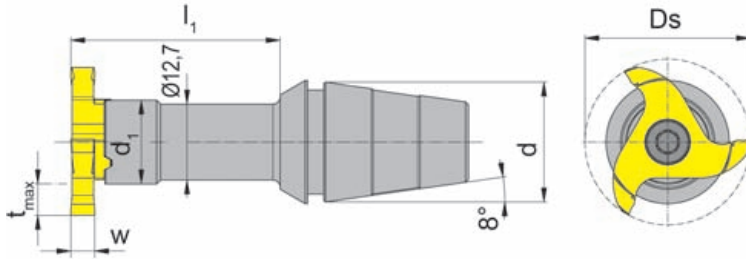

Type U325
U328
325
328
628

Picture = right hand cutting version

Part number	l_1	d_1	d	Clamping nut
M328.ER20.02	35	14	20	ER20.6499/ERM...
M328.ER25.02	35	14	25	ER25.6499
M328.ER32.02	35	14	32	ER32.6499

Further sizes upon request

w , D_s , t_{max} see inserts

Dimensions in mm

For torque specifications of the screw, please see Technical Instructions.

Ordering note:

Clamping nut is not combined with milling shank - separate order required!

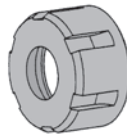

Spare parts

Milling shank	Screw	TORX PLUS® Wrench
M328.ER...	5.14T20P	T20PQ

INSERT Type

325/U325

Depth of cut up to .197"
 Cutting edge \emptyset Ds .976"

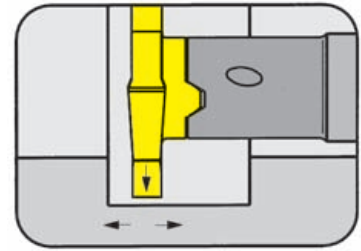

for use with Milling shank

Type MU328
 M328
 M328.ER
 M328.M

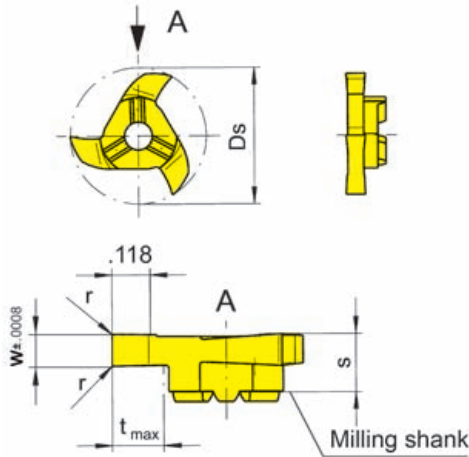

Picture = right hand cutting version

Part number	w	r	s	t _{max}	Ds	Carbide grades			
						MG12	TN35	T125	AS45
U325.0125.52	.125	.008	.197	.197	.976		▲		
325.0350.52	.138	.008	.224	.197	.976		▲		▲
						P	•	•	•
						M	•	•	•
						K	•	•	•
						N	•	•	○
						S	•	•	•
						H			

- ▲ on stock Δ 4 weeks
- main recommendation
- alternative recommendation
- uncoated grades
- coated grades
- brazed/Cermet

Dimensions in inch

Carbide grades

INSERT Type

328

Depth of groove up to	.197"
Width of groove up to	.032"
Cutting edge Ø	Ds 1.091"

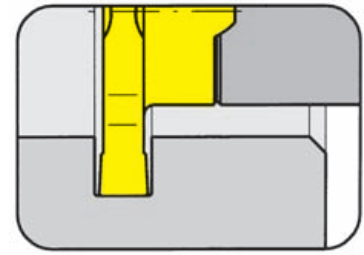

for use with Milling shank

Type MU328
M328
M328.ER
M328.M

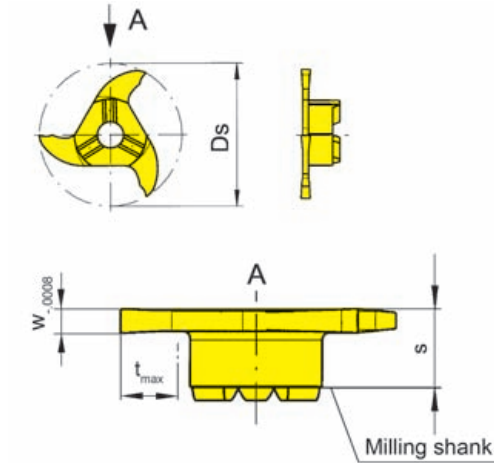

Picture = right hand cutting version

Part number	w	s	t _{max}	Ds	Carbide grades		
					MG12	TN35	TI25
328.0082.1.00	.032	.224	.197	1.091		▲	▲
▲ on stock Δ 4 weeks					P	•	•
● main recommendation					M	•	•
○ alternative recommendation					K	•	•
■ uncoated grades					N	•	•
■ coated grades					S	•	•
■ brazed/Cermet					H		

Dimensions in inch

INSERT Type

328/U328

Depth of groove up to .256"
 Width of groove up to .394"
 Cutting edge \emptyset Ds 1.091"

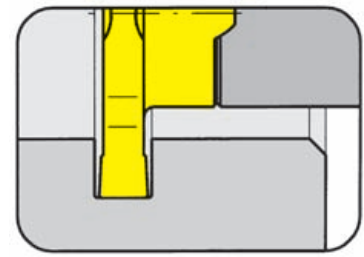

for use with Milling shank

Type MU328
 M328
 M328.ER
 M328.M

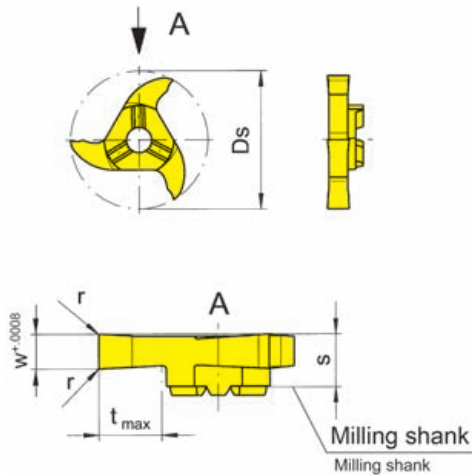

Picture = right hand cutting version

Part number	w	r	s	t _{max}	Ds	Carbide grades				
						MG12	TN35	T125	AS45	TF45
328.0200.00	.079		.224				▲		▲	
328.0250.00	.098		.224				▲		▲	
328.0300.00	.118		.224				▲		▲	
328.0350.00	.138		.224				▲		▲	
328.0400.00	.157	.008	.224	.256	1.091		▲		▲	
328.0500.00	.197		.224				▲		▲	
328.0600.00	.236		.276				▲		▲	
328.1000.00	.394		.394				▲		▲	
U328.0094.08	.094							▲		
U328.0125.08	.125							▲		Δ
U328.0157.08	.157	.008	.224	.256	1.091			▲		Δ
U328.0187.08	.187							▲		
U328.0157.16	.157							▲		
U328.0187.16	.187	.016	.224	.256	1.091			▲		Δ
▲ on stock Δ 4 weeks						P	•	•	•	•
• main recommendation						M	•	•	•	•
o alternative recommendation						K	•	•	•	•
■ uncoated grades						N	•	•	o	•
■ coated grades						S	•	•	•	•
■ brazed/Cermet						H				

Dimensions in inch

Carbide grades

Insert 328.1000.00 with staggered tooth (Z=1) and insert 328.0600.00 with chip divider!

Inserts 328.0400.00, 328.0500.00, 328.0600.00, 328.1000.00, U328.0157.08, U328.0157.16, U328.0187.08, and U328.0187.16 only with toolholder dimension l₂ = max. 1.654"

INSERT Type

328

machining of aluminium

Depth of groove up to	.256"
Width of groove up to	.157"
Cutting edge \emptyset	Ds 1.091"

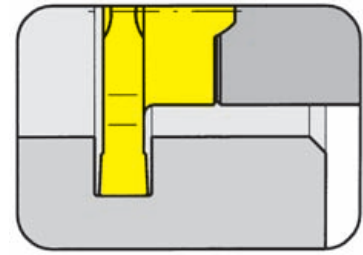

for use with Milling shank

Type MU328
M328
M328.ER
M328.M

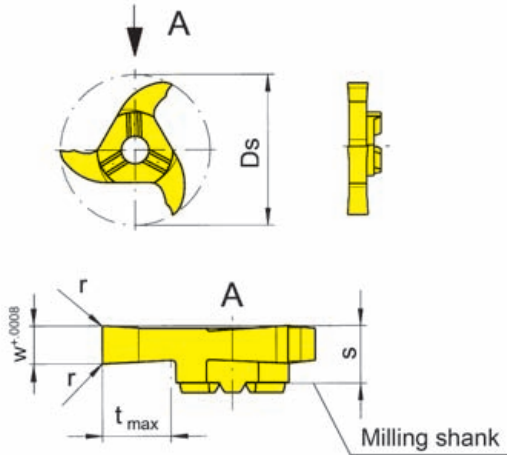

Picture = right hand cutting version

Part number	w	r	s	t _{max}	Ds	Carbide grades	
						MG12	TI25
328.0250.40	.098					▲	▲
328.0300.40	.118					▲	▲
328.0350.40	.138	.008	.224	.256	1.091	▲	▲
328.0400.40	.157					▲	▲
						P	•
						M	•
						K	•
						N	•
						S	•
						H	•

- ▲ on stock Δ 4 weeks
- main recommendation
- o alternative recommendation
- uncoated grades
- coated grades
- brazed/Cermet

Dimensions in inch

Carbide grades

Further sizes upon request

INSERT Type

328

Depth of groove up to .366"
 Width of groove up to .098"
 Cutting edge Ø Ds 1.102"

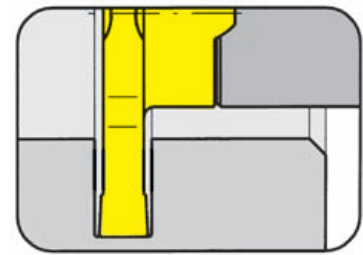

for use with Milling shank

Type M328.0909.01A
 M328.0912.01A
 M328.0912.01B

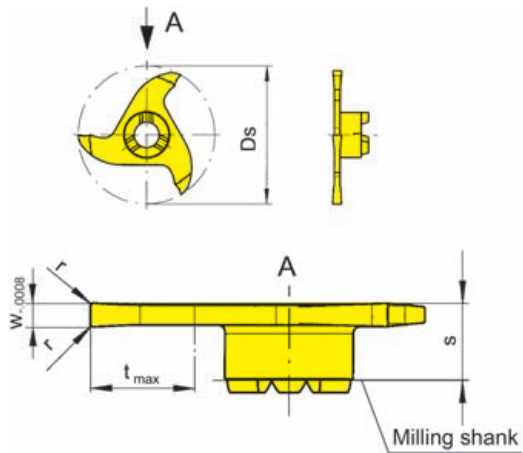

Picture = right hand cutting version

increased milling depth

Part number	w	r	s	t _{max}	Ds	Carbide grades			
						MG12	TN35	TI25	AS45
328.0110.2.00	.043	.008					▲	▲	
328.0120.2.00	.047	.008					▲	▲	
328.0132.2.00	.052	.006					▲	▲	
328.0150.2.00	.059	.008	.224	.366	1.102		▲	▲	▲
328.0160.2.00	.063	.008					▲	▲	▲
328.0200.2.00	.079	.008					▲	▲	▲
328.0250.2.00	.098	.008					▲	▲	▲
▲ on stock Δ 4 weeks ● main recommendation ○ alternative recommendation ■ uncoated grades ■ coated grades ■ brazed/Cermet						P	●	●	●
						M	●	●	●
						K	●	●	●
						N	●	●	○
						S	●	●	●
						H			

Dimensions in inch

Carbide grades

INSERT Type

628

Depth of groove up to	.256"
Width of circlip Nw	.051 - .104"
Cutting edge Ø	Ds 1.091"

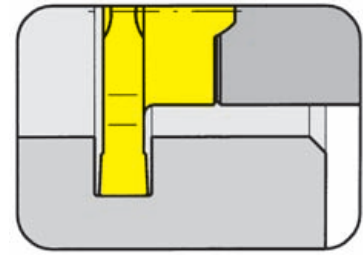

Widths for circlip grooves DIN 471/472

for use with Milling shank

Type MU328
M328
M328.ER
M328.M

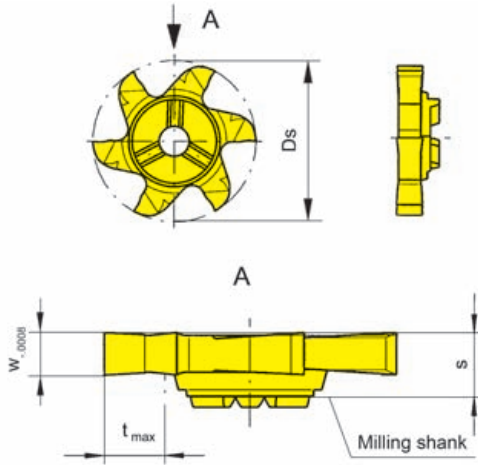

Picture = right hand cutting version

Part number	Nw	w	r	s	t _{max}	Ds	Carbide grades		
							MG12	TI25	AS45
628.0130.00	.051	.056	-					▲	
628.0160.00	.063	.067	-					▲	▲
628.0185.00	.073	.077	.008	.240	.256	1.091		▲	▲
628.0215.00	.085	.089	.008					▲	▲
628.0265.00	.104	.109	.008					▲	▲
							P	•	•
							M	•	•
							K	•	•
							N	•	○
							S	•	•
							H		

- ▲ on stock Δ 4 weeks
- main recommendation
- alternative recommendation
- uncoated grades
- coated grades
- brazed/Cermet

Dimensions in inch

Carbide grades

INSERT Type

628

Depth of groove up to .256"
 Width of groove up to .157"
 Cutting edge \emptyset Ds 1.091"

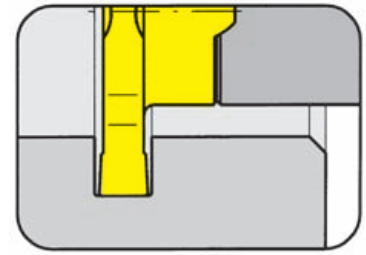

for use with Milling shank

Type MU328
 M328
 M328.ER
 M328.M

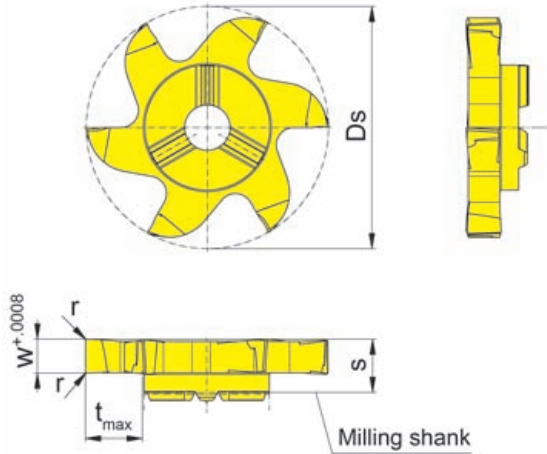

Picture = right hand cutting version

Part number	w	r	s	t _{max}	Ds	Carbide grades		
						MG12	T125	AS45
628.0250.00	.098						▲	▲
628.0300.00	.118						▲	▲
628.0350.00	.138	.008	.240	.256	1.091		▲	▲
628.0400.00	.157						▲	▲
						P	•	•
						M	•	•
						K	•	•
						N	•	○
						S	•	•
						H		

- ▲ on stock Δ 4 weeks
- main recommendation
- alternative recommendation
- uncoated grades
- coated grades
- brazed/Cermet

Dimensions in inch

Insert 628.0400.00 only with toolholder dimension l₂ = 1.654"

INSERT Type

628

Depth of groove up to .366"
 Width of groove up to .098"
 Cutting edge \emptyset Ds 1.102"



for use with Milling shank

Type M328.0909.01A
 M328.0912.01A
 M328.0912.01B

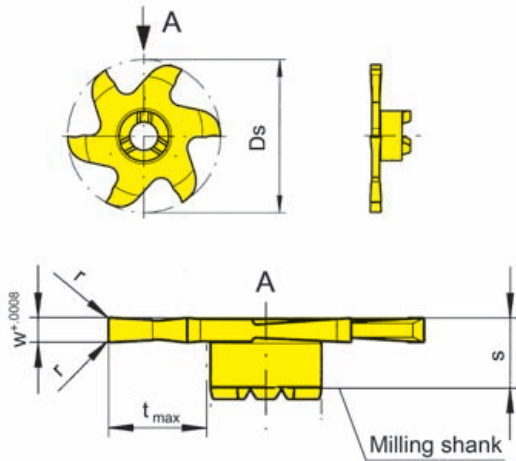

Picture = right hand cutting version

increased milling depth

Part number	w	r	s	t _{max}	Ds	MG12	TN35	TI25	AS45
628.0120.2.00	.047							▲	
628.0150.2.00	.059							▲	▲
628.0160.2.00	.063	.008	.240	.366	1.102			▲	▲
628.0200.2.00	.079							▲	▲
628.0240.2.00	.094							▲	▲
628.0250.2.00	.098							▲	▲
						P		•	•
						M		•	•
						K		•	•
						N		•	o
						S		•	•
						H			

- ▲ on stock Δ 4 weeks
- main recommendation
- o alternative recommendation
- uncoated grades
- coated grades
- brazed/Cermet

P		•	•
M		•	•
K		•	•
N		•	o
S		•	•
H			

Carbide grades

Dimensions in inch

SOLUTIONS PLUS Program

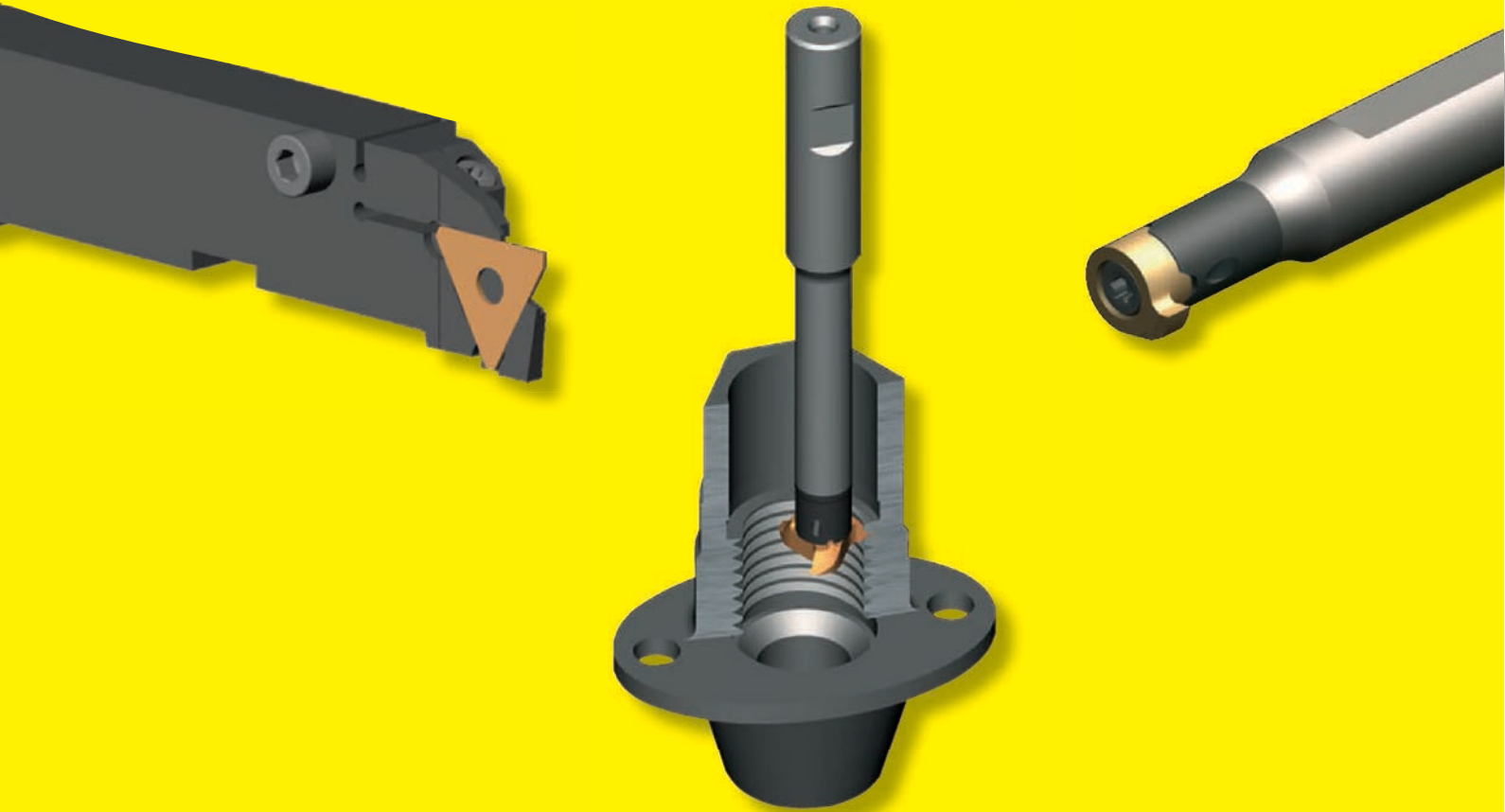

**Need faster delivery?
Inquire about our Solutions Plus Program.**



MILLING SHANK type **M332**

from bore \varnothing 1.260" (32.0 mm)



MILLING SHANK Type

MU332

with through coolant supply

Cutting edge \emptyset

Ds 1.248"

Material of shank: Carbide - Giving a good vibration resistance

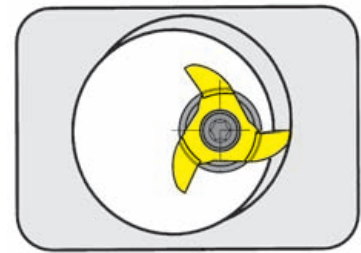

for use with Insert

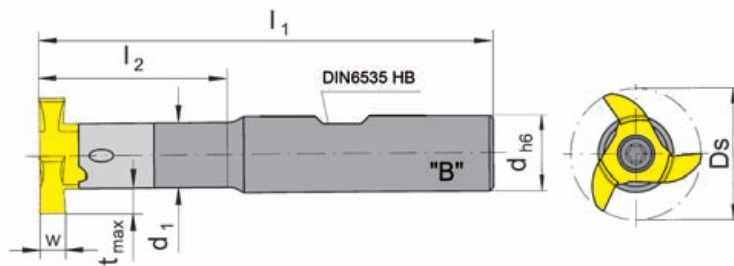
 Type 332
 632
 636

Picture = right hand cutting version

Part number	l_1	l_2	d_1	d
MU332.0625.01B	3.937	1.654		
MU332.0625.02B	5.118	2.362	.563	.625
MU332.0625.03B	6.299	3.346		
MU332.0750.01B	3.937	1.654		
MU332.0750.02B	5.118	2.362	.563	.750
MU332.0750.03B	6.299	3.346		

Further sizes upon request

w, Ds, t_{max} see inserts

Dimensions in inch

Ordering note:

Milling cutter shanks with damaged seating can be repaired by HORN.

For torque specifications of the screw, please see Technical Instructions.

Spare parts

Milling shank	Screw	TORX PLUS® Wrench
MU332.0...	5.17T20P	T20PQ

MILLING SHANK Type

M332

with through coolant supply

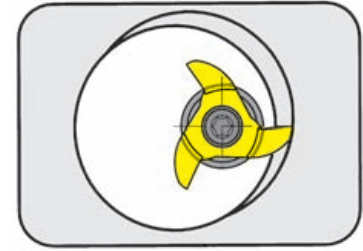

Cutting edge \emptyset

Ds 1.248" (31.7 mm)

Material of shank: Carbide - Giving a good vibration resistance

for use with Insert

Type 332
632
636

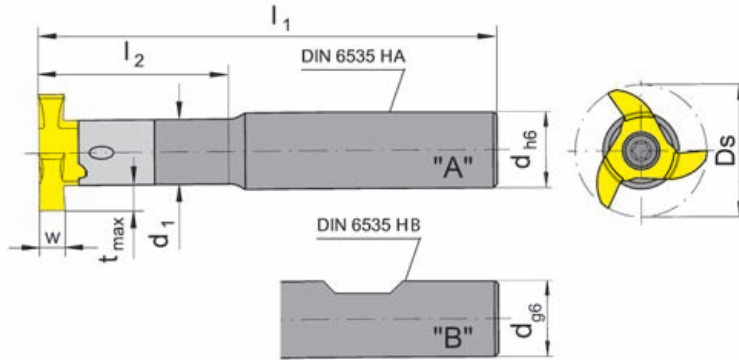

Picture = right hand cutting version

Part number	l_1	l_2	d_1	d	Form
M332.0016.01A	100	42	14.3	16	A
M332.0016.02A	130	60			
M332.0016.03A	160	85			
M332.0020.01A	100	42	14.3	20	A
M332.0020.02A	130	60			
M332.0020.03A	160	85			
M332.0016.01B	100	42	14.3	16	B
M332.0016.02B	130	60			
M332.0016.03B	160	85			
M332.0020.01B	100	42	14.3	20	B
M332.0020.02B	130	60			
M332.0020.03B	160	85			

Further sizes upon request

w, Ds, t_{max} see inserts

Dimensions in mm

Ordering note:

Milling cutter shanks with damaged seating can be repaired by HORN.

For torque specifications of the screw, please see Technical Instructions.

Spare parts

Milling shank	Screw	TORX PLUS® Wrench
M332.00...	5.17T20P	T20PQ

MILLING SHANK Type

M332

with through coolant supply

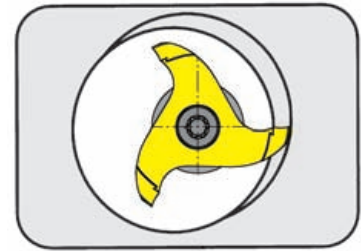
Cutting edge \varnothing

Ds 1.248" (31.7 mm)

Material of shank: Carbide - Giving a good vibration resistance

for use with Insert

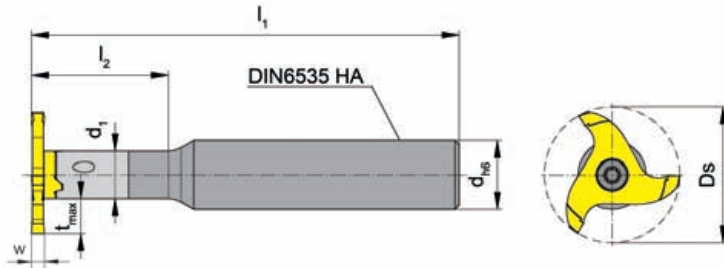
 Type 332
 632
 636

Picture = right hand cutting version

 for inserts with increased
 milling depth

Part number	l_1	l_2	d_1	d
M332.0012.2.01A	100	32	11	12
M332.0016.2.01A				16

Further sizes upon request

w, Ds, t_{max} see inserts

Dimensions in mm

Ordering note:

Milling cutter shanks with damaged seating can be repaired by HORN.

For torque specifications of the screw, please see Technical Instructions.

Spare parts

Milling shank	Screw	TORX PLUS® Wrench
M332.001...	5.17T20P	T20PQ

MILLING SHANK Type

M332.ST

no coolant supply

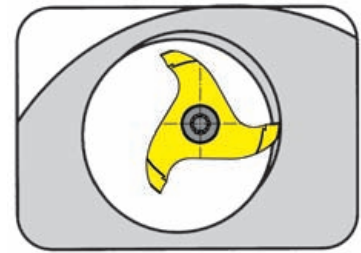

Cylindrical steel milling shank for collets Ds 31.7 mm

with cylindrical shank for CNC-lathes

for use with Insert

Type 332
632
636

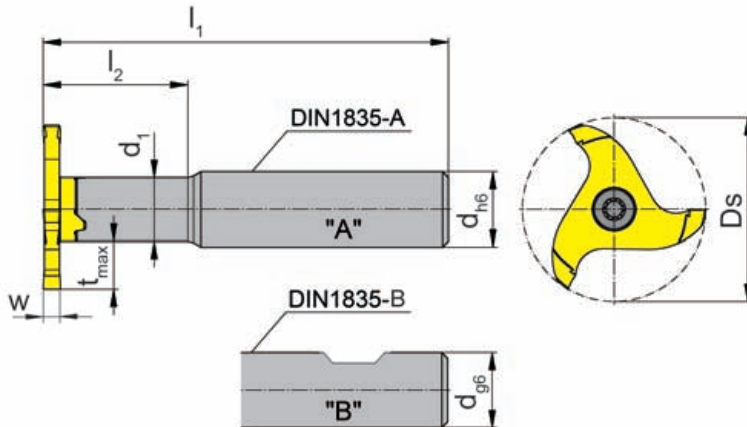

Picture = right hand cutting version

Part number	l_1	l_2	d_1	d	Form
M332.ST16.01A	90	36	14.3	16	A
M332.ST20.01A	100			20	
M332.ST12.2.01A	70	25	11.0	12	A
M332.ST13.2.01A				13	
M332.ST12.2.01B	70	25	11.0	12	B

Further sizes upon request

w, Ds, t_{max} see inserts

Dimensions in mm

Note:

Milling shanks **M332.ST12.2.01A**, **M332.ST12.2.01B** and **M332.ST13.2.01A** are usable for inserts with increased milling depth!

For torque specifications of the screw, please see Technical Instructions.

Spare parts

Milling shank	Screw	TORX PLUS® Wrench
M332.ST...	5.17T20P	T20PQ

SCREW-IN CUTTER Type

M332.M

no coolant supply

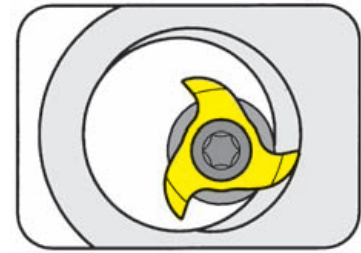

Screw-in Cutter for basic holder type WFB.20

for use with Insert

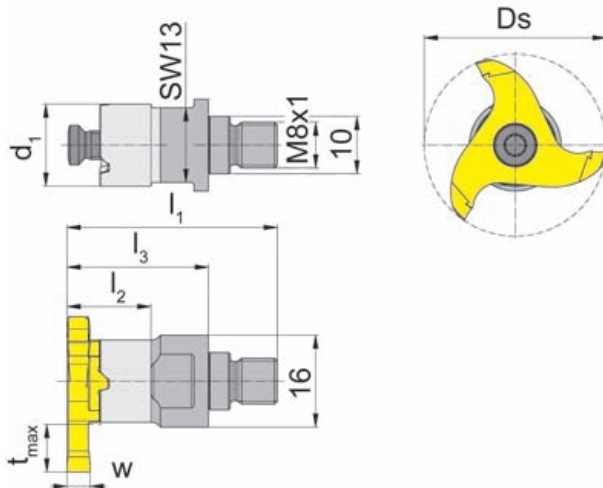
 Type 332
 632
 636

Picture = right hand cutting version

Part number	l_1	l_2	l_3	d_1
M332.M081.01	37	15	25	14.3

Further sizes upon request

w, Ds, t_{max} see inserts

Dimensions in mm

For torque specifications of the screw, please see Technical Instructions.

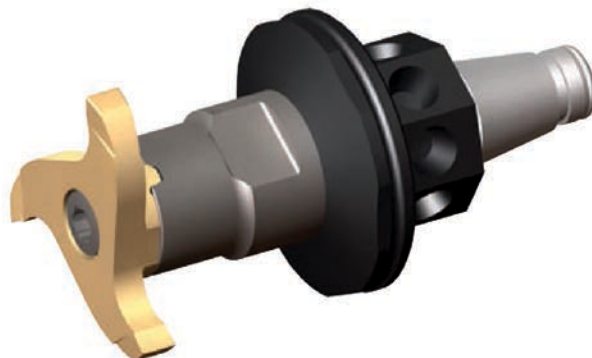

Spare parts

Screw-in cutter	Screw	TORX PLUS® Wrench
M332.M081.01	5.17T20P	T20PQ

BASIC HOLDER Type

WFB

Basic holder WFB.20 for screw-in cutter

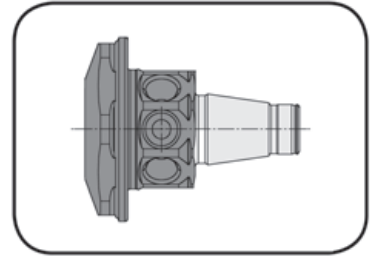

for use with Screw-in cutter

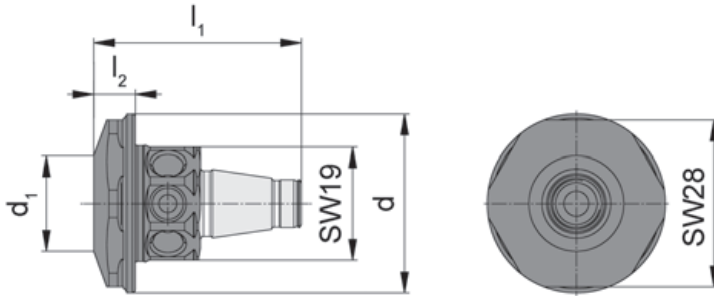

- Type
- M306.M081...
 - M308.M081...
 - M311.M081...
 - M313.M081...
 - M328.M081...
 - M332.M081...

Part number	l_1	l_2	d_1	d
WFB.2012.M081.01	35	7	16	30

Further sizes upon request

Dimensions in mm



MILLING SHANK Type

M332.ER

no coolant supply

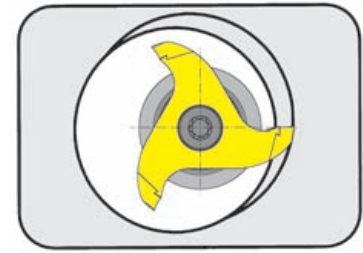

Milling shanks for collet chucks DIN6499-A (8°) Ds 31.7/35,7 mm

with ER taper for CNC-lathes

for use with Insert

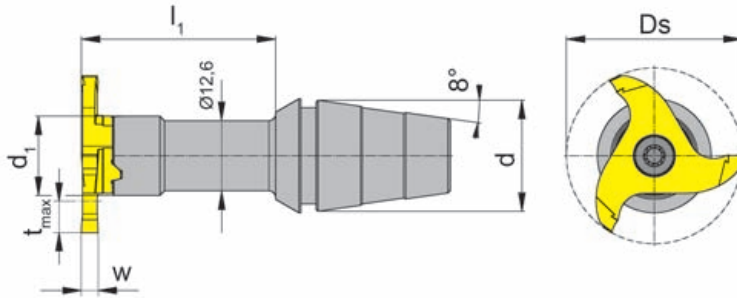
 Type 332
 632
 636

Picture = right hand cutting version

Part number	l_1	d_1	d	Clamping nut
M332.ER20.02	35	14.3	20	ER20.6499/ERM20.6499

Further sizes upon request

w, Ds, t_{max} see inserts

Dimensions in mm

For torque specifications of the screw, please see Technical Instructions.

Ordering note:

Clamping nut is not combined with milling shank - separate order required!

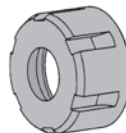
**Spare parts**

Milling shank	Screw	TORX PLUS® Wrench
M332.ER20.02	5.17T20P	T20PQ

INSERT Type

332

Depth of groove up to .327"
 Width of groove up to .157"
 Cutting edge Ø Ds 1.248"

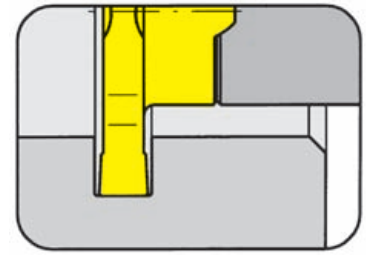

for use with Milling shank

Type MU332
 M332
 M332.ER
 M332.M

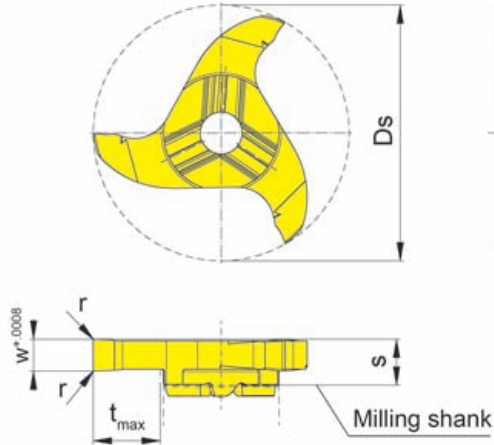

Picture = right hand cutting version

Part number	w	r	s	t _{max}	Ds	Carbide grades			
						MG12	TN35	TI25	AS45
332.0200.00	.079							▲	△
332.0250.00	.098							▲	△
332.0300.00	.118	.008	.224	.327	1.248			▲	△
332.0350.00	.138							▲	△
332.0400.00	.157							▲	△
						P		●	●
						M		●	●
						K		●	●
						N		●	○
						S		●	●
						H			

- ▲ on stock △ 4 weeks
- main recommendation
- alternative recommendation
- uncoated grades
- coated grades
- brazed/Cermet

Dimensions in inch

Carbide grades

INSERT Type

332

Depth of groove up to .394"
 Width of groove up to .118"
 Cutting edge \emptyset Ds 1.248"

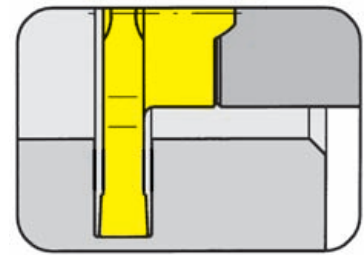

for use with Milling shank

- Type M332.0012.2.01A
 M332.0016.2.01A
 M332.ST12.2.01A
 M332.ST12.2.01B
 M332.ST13.2.01A

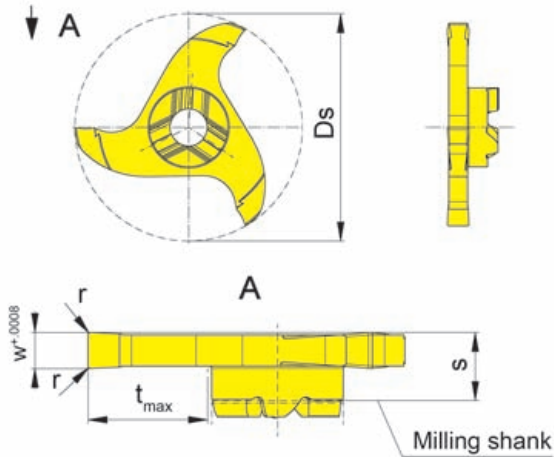

Picture = right hand cutting version

increased milling depth

Part number	w	r	s	t _{max}	Ds	Carbide grades			
						MG12	TN35	TI25	AS45
332.0150.2.00	.059							▲	△
332.0160.2.00	.063							▲	△
332.0200.2.00	.079	.008	.224	.394	1.248			▲	△
332.0250.2.00	.098							▲	△
332.0300.2.00	.118							▲	△
						P		●	●
						M		●	●
						K		●	●
						N		●	○
						S		●	●
						H			

- ▲ on stock △ 4 weeks
- main recommendation
- alternative recommendation
- uncoated grades
- coated grades
- brazed/Cermet

Dimensions in inch

Carbide grades

INSERT Type

632

Depth of groove up to .327"
 Width of groove up to .157"
 Cutting edge Ø Ds 1.248"

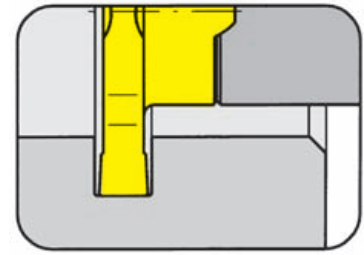

for use with Milling shank

Type MU332
 M332
 M332.ER
 M332.M

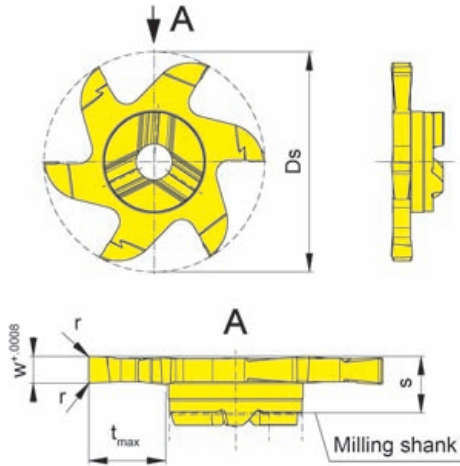

Picture = right hand cutting version

Part number	w	r	s	t _{max}	Ds	Carbide grades				
						MG12	TN35	T125	TA45	AS45
632.0200.00	.079								▲	△
632.0250.00	.098								▲	△
632.0300.00	.118	.008	.240	.327	1.248				▲	△
632.0400.00	.157								▲	△
▲ on stock △ 4 weeks ● main recommendation ○ alternative recommendation ■ uncoated grades ■ coated grades ■ brazed/Cermet						P			●	●
						M			●	●
						K			●	●
						N			●	○
						S			●	●
						H				

Dimensions in inch

Carbide grades

INSERT Type

632

Depth of groove up to .394"
 Width of groove up to .118"
 Cutting edge \emptyset Ds 1.248"

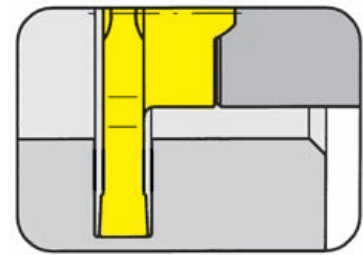

for use with Milling shank

- Type M332.0012.2.01A
 M332.0016.2.01A
 M332.ST12.2.01A
 M332.ST12.2.01B
 M332.ST13.2.01A

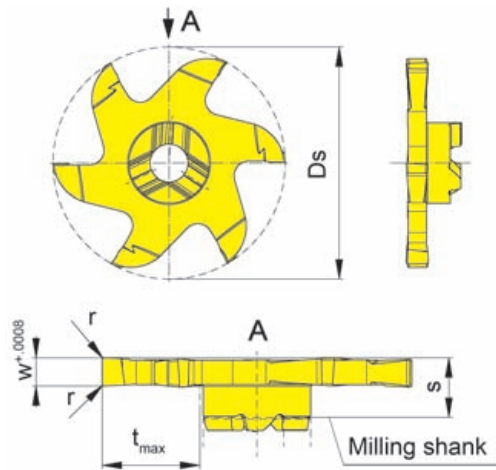

Picture = right hand cutting version

increased milling depth

Part number	w	r	s	t _{max}	Ds	Carbide grades				
						MG12	TN35	T125	TA45	AS45
632.0150.2.00	.059								▲	△
632.0160.2.00	.063								▲	△
632.0200.2.00	.079	.008	.240	.394	1.248				▲	△
632.0250.2.00	.098								▲	△
632.0300.2.00	.118								▲	△
▲ on stock △ 4 weeks ● main recommendation ○ alternative recommendation ■ uncoated grades ■ coated grades ■ brazed/Cermet						P			●	●
						M			●	●
						K			●	●
						N			●	○
						S			●	●
						H				

Dimensions in inch

INSERT Type

636

Depth of groove up to .402"
 Width of groove up to .118"
 Cutting edge \emptyset Ds 1.406"

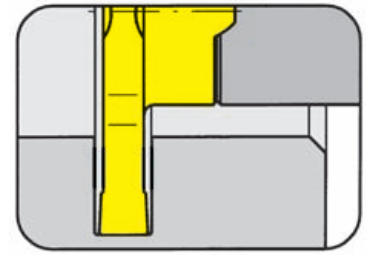

for use with Milling shank

Type MU332
 M332
 M332.ER
 M332.M

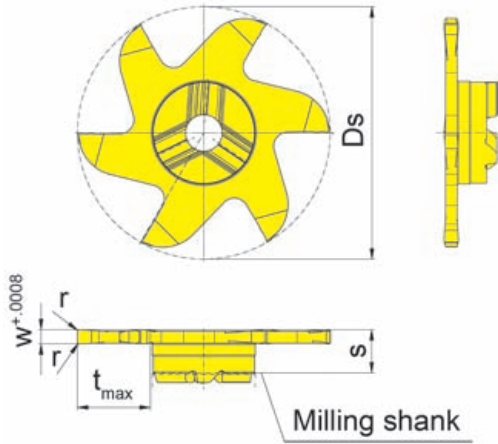

Picture = right hand cutting version

Part number	w	r	s	t _{max}	Ds	Carbide grades				
						MG12	TN35	T125	TA45	AS45
636.0150.00	.059	.004							▲	△
636.0200.00	.079	.008							▲	△
636.0250.00	.098	.008	.240	.402	1.406				▲	△
636.0300.00	.118	.008							▲	△
▲ on stock △ 4 weeks ● main recommendation ○ alternative recommendation ■ uncoated grades ■ coated grades ■ brazed/Cermet						P			●	●
						M			●	●
						K			●	●
						N			●	○
						S			●	●
						H				

Dimensions in inch

Carbide grades

INSERT Type

636

Depth of groove up to .472"
 Width of groove up to .098"
 Cutting edge Ø Ds 1.406"

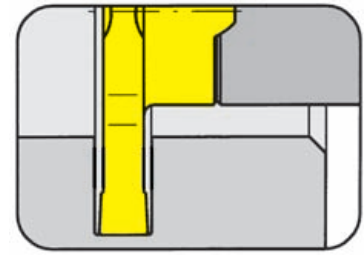

for use with Milling shank

- Type M332.0012.2.01A
 M332.0016.2.01A
 M332.ST12.2.01A
 M332.ST12.2.01B
 M332.ST13.2.01A

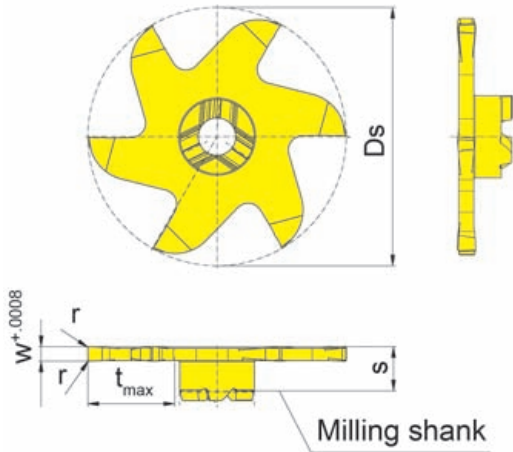

Picture = right hand cutting version

increased milling depth

Part number	w	r	s	t _{max}	Ds	Carbide grades				
						MG12	TN35	T125	TA45	AS45
636.0150.2.00	.059	.004							▲	△
636.0200.2.00	.079	.008	.240	.472	1.406				▲	△
636.0250.2.00	.098	.008							▲	△
						P			●	●
						M			●	●
						K			●	●
						N			●	○
						S			●	●
						H				

- ▲ on stock △ 4 weeks
- main recommendation
- alternative recommendation
- uncoated grades
- coated grades
- brazed/Cermet

Dimensions in inch

Carbide grades

Reducing of tool change
from Ø .709" (18 mm)

Pregrooving and Chamfering

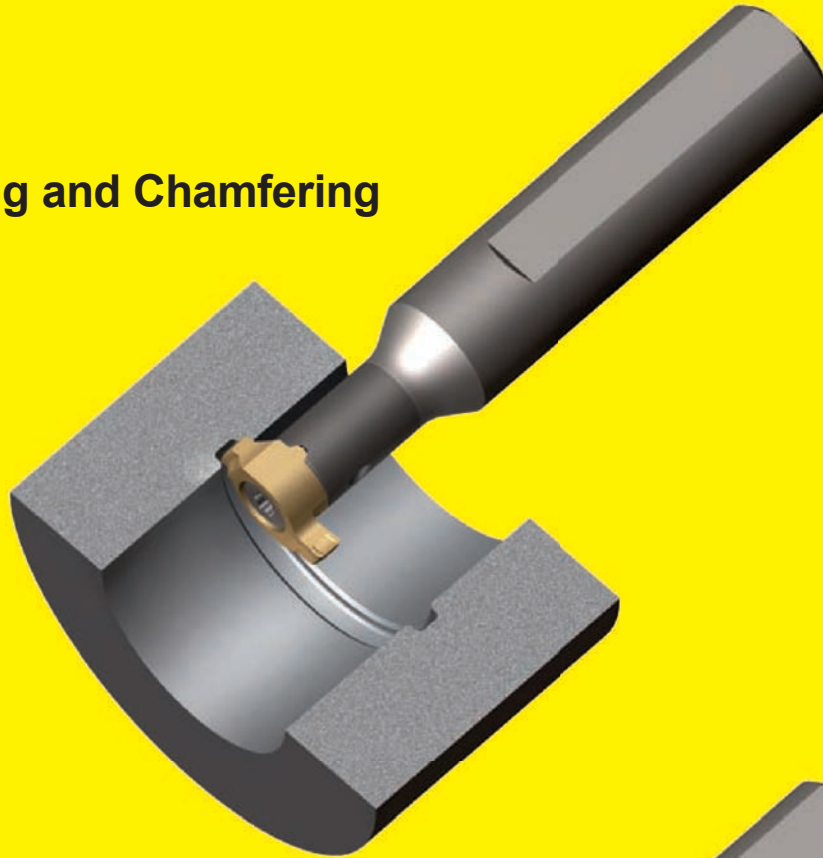

Finishing

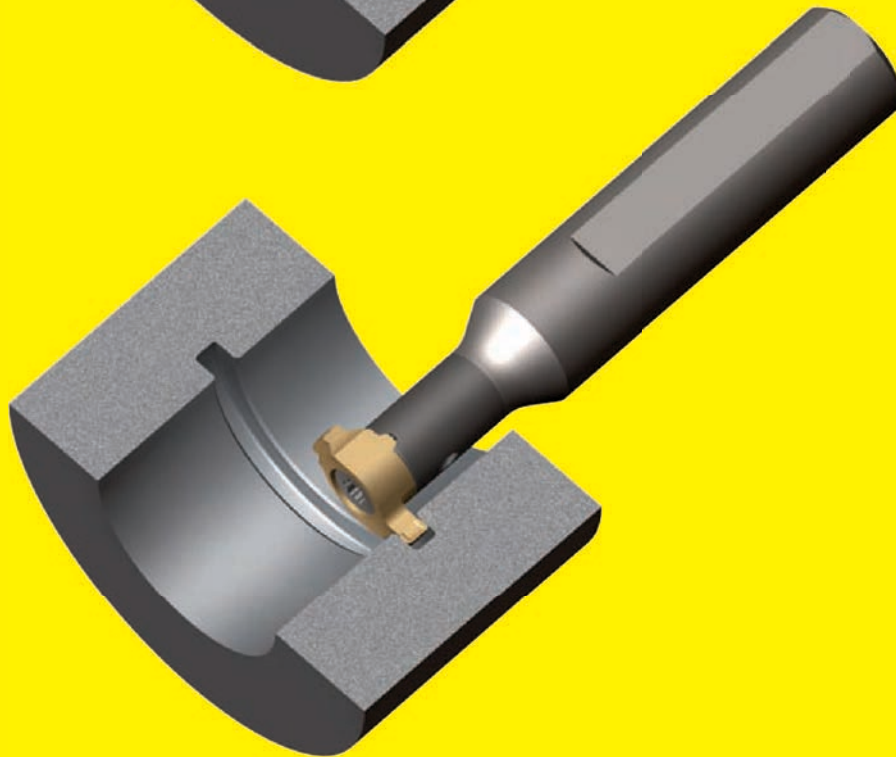

For further information, please contact HORN USA.



Carbide milling cutter shanks offer excellent antivibration properties, resulting in greater rigidity, ideally suited for holding PCD tipped inserts.



PCD tipped inserts of the 306, 308, 311, 313 and 328 range are manufactured according to customers requirements. Intermediate widths as well as complicated forms are all part of our product range.

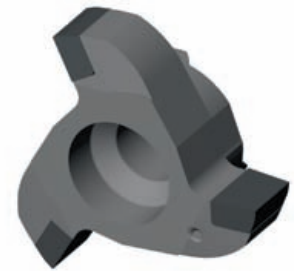

Cutting data calculated from our HCT program guarantees both optimum and economical performance of the HORN groove milling tools.



MILLING SHANK type **M335**
from bore \varnothing 1.378" (35.0 mm)



MILLING SHANK Type

MU335

with through coolant supply

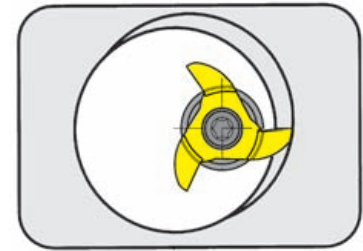
Cutting edge \emptyset

Ds 1.366"

Material of shank: Carbide - Giving a good vibration resistance

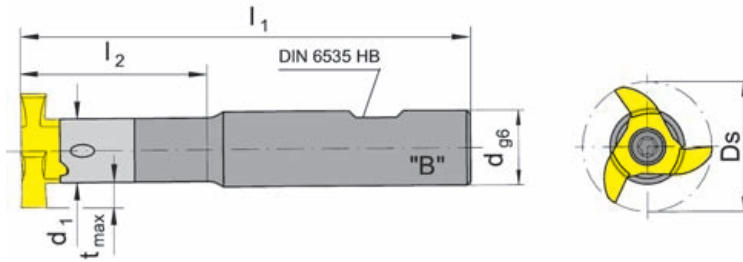

for use with Insert

Type 335

Picture = right hand cutting version

Part number	l_1	l_2	d_1	d
MU335.0750.01B	3.937	1.575		
MU335.0750.02B	5.118	2.362	.689	.750
MU335.0750.03B	6.299	3.346		

Further sizes upon request

w, Ds, t_{max} see inserts

Dimensions in inch

Ordering note:

Milling cutter shanks with damaged seating can be repaired by HORN.

For torque specifications of the screw, please see Technical Instructions.

Spare parts

Milling shank	Screw	TORX PLUS® Wrench
MU335.0750.0...	6.17T25P	T25PQ

MILLING SHANK Type

M335

with through coolant supply

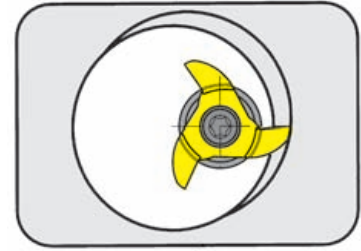

Cutting edge Ø

Ds 1.366" (34.7 mm)

Material of shank: Carbide - Giving a good vibration resistance

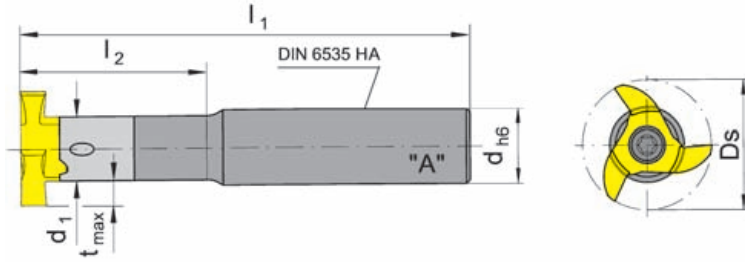

for use with Insert

Type 335

Picture = right hand cutting version

Part number	l_1	l_2	d_1	d
M335.0020.01A	100	40	17.5	20
M335.0020.02A	130	60	17.5	20

Further sizes upon request

w, Ds, t_{max} see inserts

Dimensions in mm

Ordering note:

Milling cutter shanks with damaged seating can be repaired by HORN.

For torque specifications of the screw, please see Technical Instructions.

Spare parts

Milling shank	Screw	TORX PLUS® Wrench
M335.0020.0...	6.17T25P	T25PQ

MILLING SHANK Type

M335

with through coolant supply

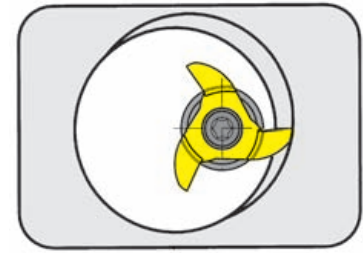
Cutting edge \emptyset

Ds 1.366" (34.7 mm)

Material of shank: Carbide - Giving a good vibration resistance

for use with Insert

Type 335

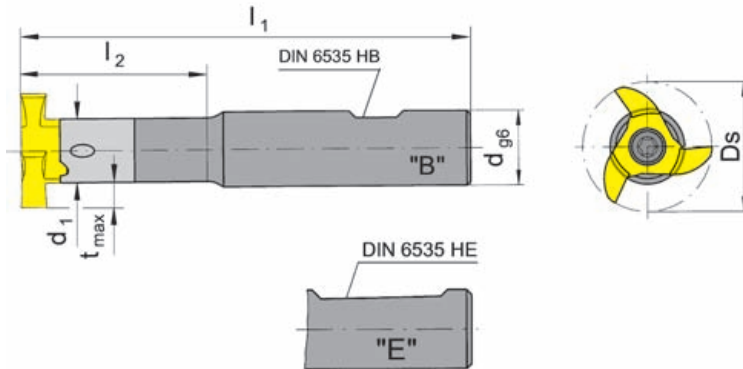

Picture = right hand cutting version

Part number	l_1	l_2	d_1	d	Form
M335.0020.01B	100	40	17.5	20	B
M335.0020.02B	130	60	17.5	20	B
M335.0020.02E	130	60	17.5	20	E

Further sizes upon request

w, Ds, t_{max} see inserts

Dimensions in mm

Ordering note:

Milling cutter shanks with damaged seating can be repaired by HORN.

For torque specifications of the screw, please see Technical Instructions.

Spare parts

Milling shank	Screw	TORX PLUS® Wrench
M335.0020.0...	6.17T25P	T25PQ

INSERT Type

335

Depth of groove up to .315"
 Width of groove up to .236"
 Cutting edge \emptyset Ds 1.366"

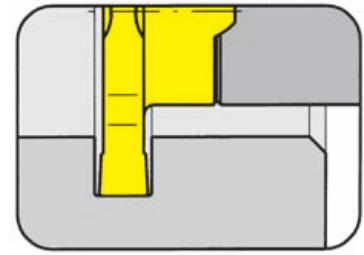

for use with Milling shank

Type M335
 MU335

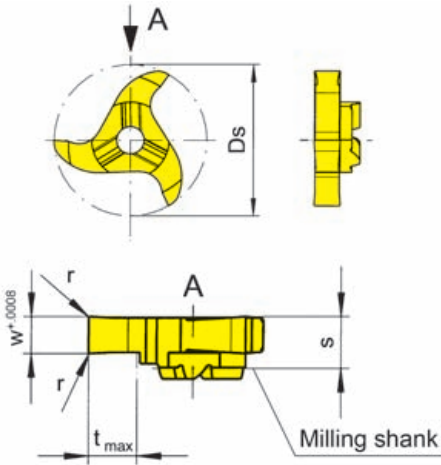

Picture = right hand cutting version

Part number	w	r	s	t _{max}	Ds	Carbide grades			
						MG12	TN35	TI25	AS45
335.0200.00	.079							▲	▲
335.0300.00	.118							▲	▲
335.0400.00	.157	.008	.343	.315	1.366			▲	▲
335.0500.00	.197							▲	▲
335.0600.00	.236							▲	▲
						P		●	●
						M		●	●
						K		●	●
						N		●	○
						S		●	●
						H			

- ▲ on stock Δ 4 weeks
- main recommendation
- alternative recommendation
- uncoated grades
- coated grades
- brazed/Cermet

Dimensions in inch

Carbide grades