

Grooving, boring, face grooving, threading $\geq \text{Ø } .008''$ (0.2 mm)

The same toolholder can be used for all inserts

Type 105

- special shaped backend of inserts guarantees accurate center height and indexability without resetting the machine
- through coolant supply
- enlarged backend of inserts gives a rigid clamping and good vibration resistance

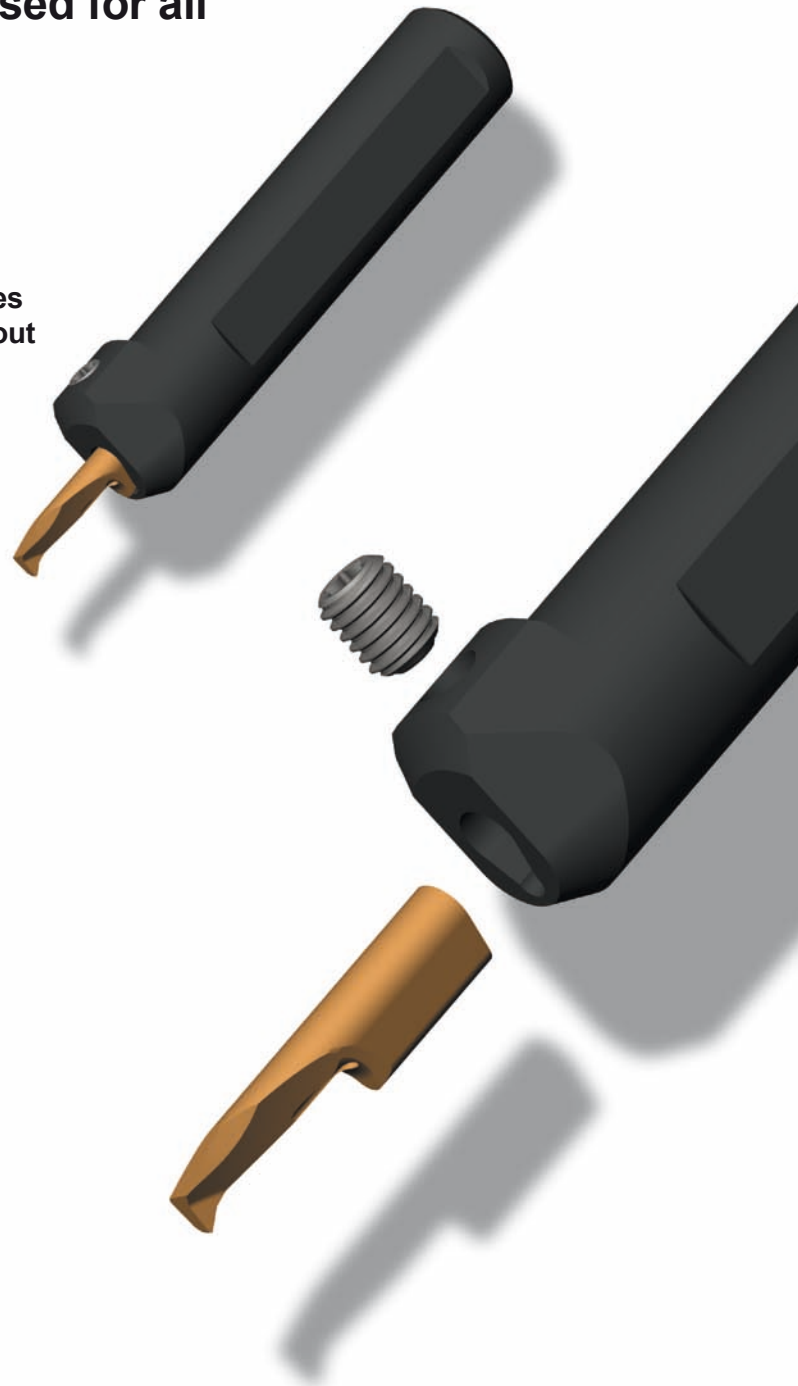

TOOLHOLDER Type

BU105

with through coolant supply

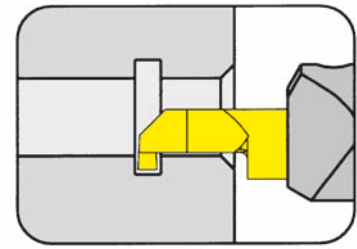

Bore Ø from	.008"
Depth of groove up to	.098"
Width of groove up to	.079"

for use with Insert

Type 105
U105

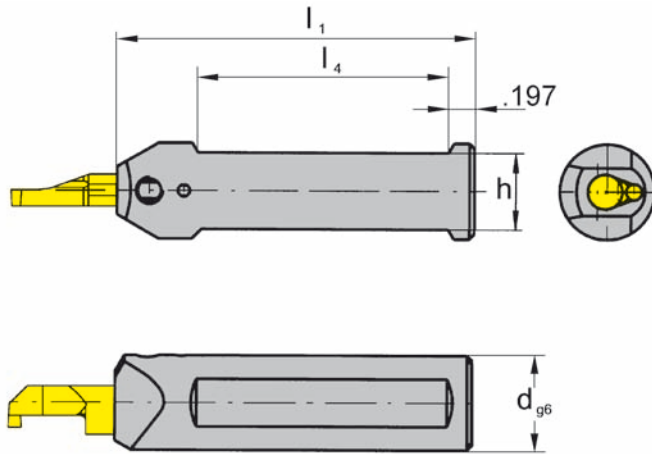

Picture = right hand cutting version shown

Part number	d	l ₁	h	l ₄
BU105.0500.01	.500	2.950	.433	2.160
BU105.0625.01	.625	2.950	.551	2.160
BU105.0750.01	.750	3.540	.671	2.750
BU105.1000.01	1.000	3.540	.921	2.750

Further sizes upon request

Dimensions in inch

Ordering note:

Toolholders can be used with right and left hand inserts.

Spare parts

Toolholder	Screw	TORX PLUS® Wrench
BU105....	6.075T15P	T15PQ

TOOLHOLDER Type

B105

with through coolant supply

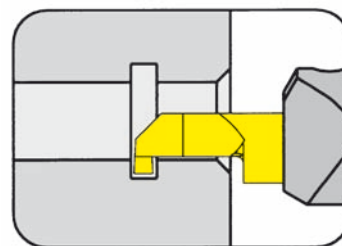

Bore Ø from	.008" (0.2 mm)
Depth of groove up to	.098" (2.5 mm)
Width of groove up to	.079" (2.0 mm)

for use with Insert

Type 105
U105

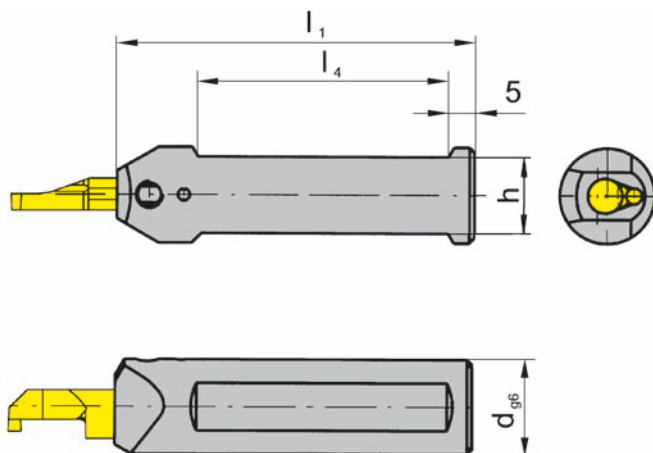

Picture = right hand cutting version shown

Part number	d	l ₁	h	l ₄
B105.0010.01	10	75	9	50
B105.0012.01	12	75	11	50
B105.0016.01	16	75	14	50
B105.0020.01	20	90	18	55
B105.0025.01	25	100	23	55

Further sizes upon request

Dimensions in mm

Ordering note:

Toolholders can be used with right and left hand inserts.

Spare parts

Toolholder	Screw	TORX PLUS® Wrench
B105.00...	6.075T15P	T15PQ

TOOLHOLDER Type

B105/BU105

with through coolant supply

Bore Ø from	.008" (0.2 mm)
Depth of groove up to	.098" (2.5 mm)
Width of groove up to	.079" (2.0 mm)

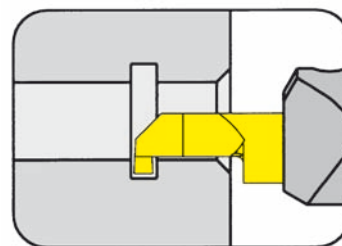

for use with Insert

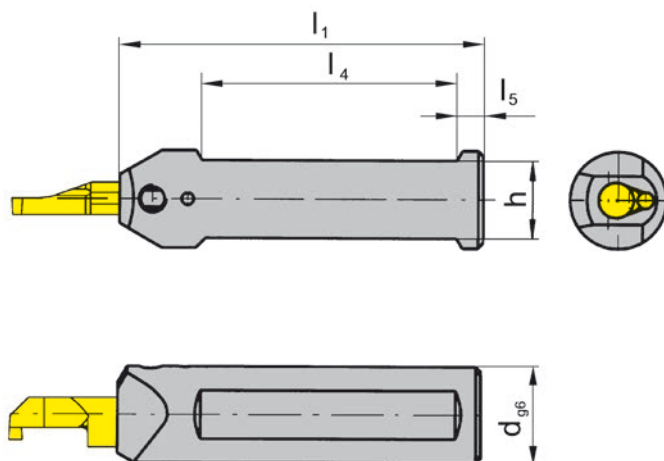
Type 105
U105

Picture = right hand cutting version shown

Part number	d	l ₁	h	l ₄	l ₅	Remark
B105.0022.01	22.00	90.0	20.00	55	5	-
B105.0028.01	28.00	120.0	26.00	72	12	**
BU105.0750.5.01	3/4"	90.0	17.04	70	5	**
BU105.0750.5.3.01	3/4"	152.5	17.05	70	5	**
BU105.1000.5.01	1"	90.0	23.40	65	5	**
BU105.1000.5.3.01	1"	152.5	23.40	70	5	**

Further sizes upon request

Dimensions in mm

** Adapter of cooling M12x1,5 for Traub

Ordering note:

Toolholders can be used with right and left hand inserts.

Spare parts

Toolholder	Screw	TORX PLUS® Wrench
B/BU105...	6.075T15P	T15PQ

TOOLHOLDER Type

B105

with through coolant supply

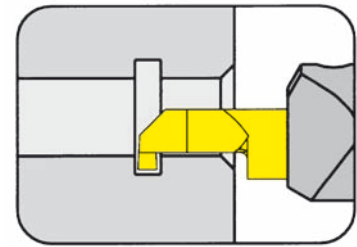

Bore Ø from	.008" (0.2 mm)
Depth of groove up to	.098" (2.5 mm)
Width of groove up to	.079" (2.0 mm)

for use with Insert

Type 105
U105

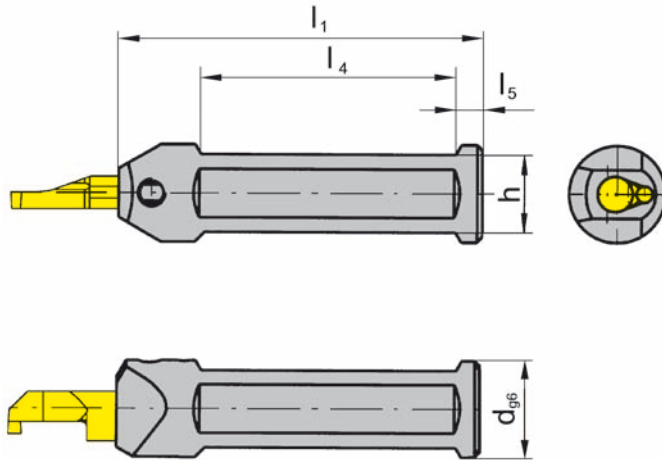

Picture = right hand cutting version shown

Part number	d	l ₁	h	l ₄	l ₅
B105.0022.1.2.01	22	120	20	72	5

Further sizes upon request

Dimensions in mm

Ordering note:

Toolholders can be used with right and left hand inserts.

Spare parts

Toolholder	Screw	TORX PLUS® Wrench
B105.0022.1.2.01	6.075T15P	T15PQ

TOOLHOLDER Type

B105

with through coolant supply

Bore Ø from	.008" (0.2 mm)
Depth of groove up to	.098" (2.5 mm)
Width of groove up to	.079" (2.0 mm)

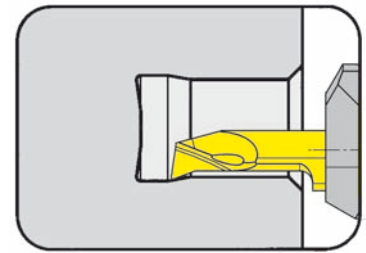

for use with Insert

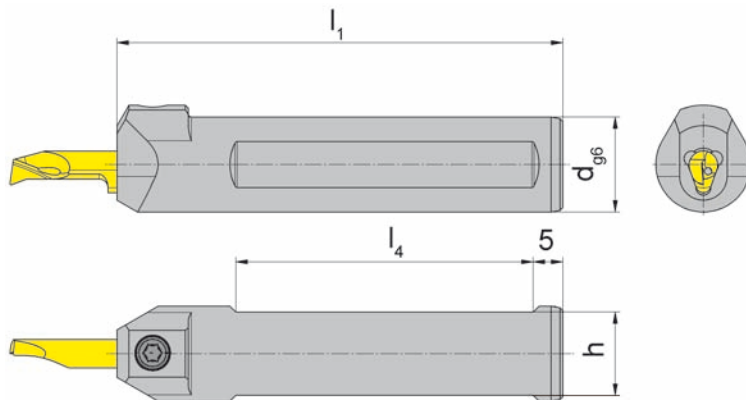
Type 105
U105

Picture = right hand cutting version shown

with additional through
coolant bores

Part number	d	l ₁	h	l ₄
B105.0012.K.01	12	75	11	50
B105.0016.K.01	16	75	14	50
B105.0020.K.01	20	90	18	50

Further sizes upon request

Dimensions in mm

Ordering note:

Toolholders can be used with right and left hand inserts.

Spare parts

Toolholder	Screw	TORX PLUS® Wrench
B105.00...	6.075T15P	T15PQ

TOOLHOLDER Type

B105

with through coolant supply

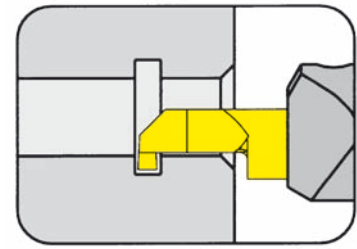

Bore Ø from	.008" (0.2 mm)
Depth of groove up to	.098" (2.5 mm)
Width of groove up to	.079" (2.0 mm)

for use with Insert

Type 105
U105

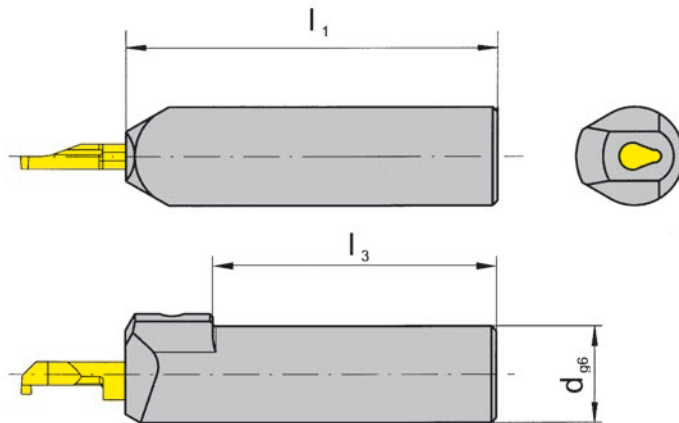

Picture = right hand cutting version shown

Part number	d	l ₁	l ₃
B105.0010.01A	10	75	57
B105.0012.01A	12	75	63
B105.0016.01A	16	75	63

Further sizes upon request

Dimensions in mm

Ordering note:

Toolholders can be used with right and left hand inserts.

Spare parts

Toolholder	Screw	TORX PLUS® Wrench
B105.001...	6.075T15P	T15PQ

TOOLHOLDER Type

B105

with through coolant supply

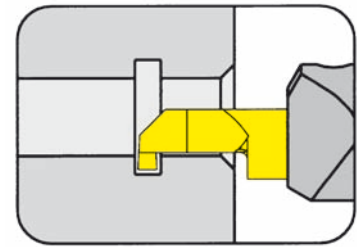

Bore Ø from	.008" (0.2 mm)
Depth of groove up to	.098" (2.5 mm)
Width of groove up to	.079" (2.0 mm)

for use with Insert

Type 105
U105

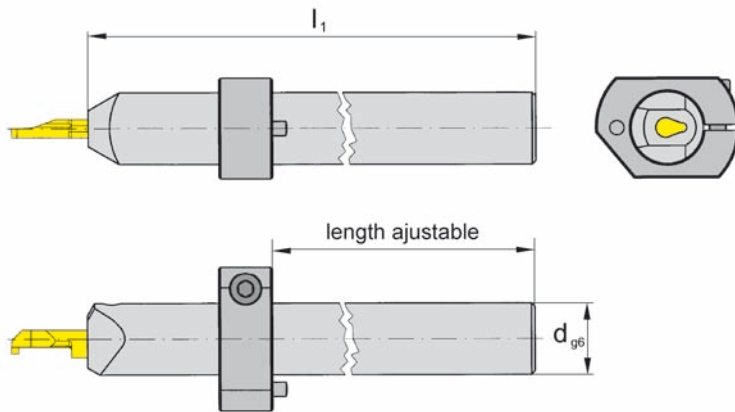

Picture = right hand cutting version shown

Part number	d	l ₁
B105.0020.2.01	20	150
B105.0025.2.01	25	150

Further sizes upon request

Dimensions in mm

Ordering note:

Toolholders can be used with right and left hand inserts.

Adjusting ring is not combined with the toolholder - separate order required!

Adjusting ring

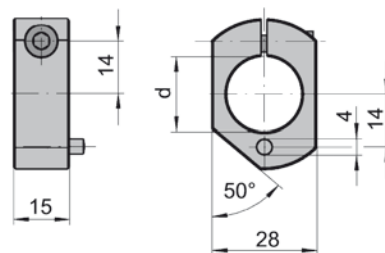

Part number "Adjusting ring"	d	Type of machine
020.0020.1665	20	Tornos DECO
020.0025.2234	25	

TOOLHOLDER Type

B105

with through coolant supply

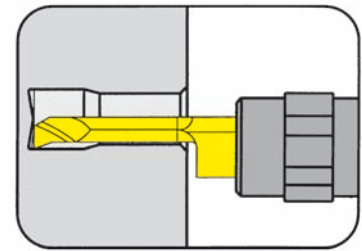

Bore Ø from $\leq .118"$ (3.0mm) or $\geq .197"$ (5.0mm)

for use with Insert

Type 105/U105
 (Ø $\leq .118"$ /3.0mm)
 (Ø $\geq .197"$ /5.0mm)

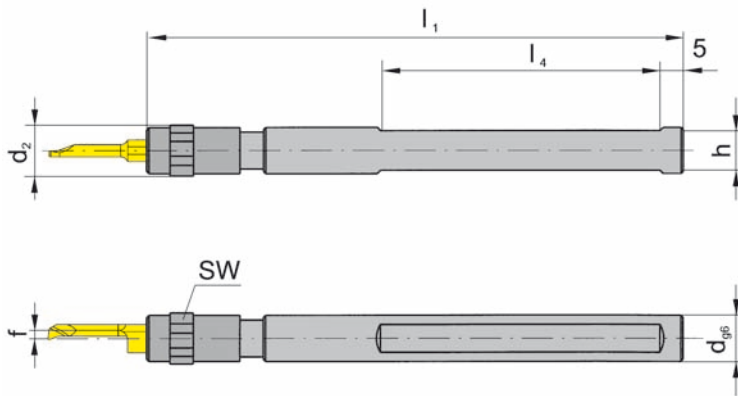

Picture = right hand cutting version shown

Part number	d	l ₁	h	d ₂	l ₄	Bore Range	SW
B105.0010.9.01	10	100	9	11	50	* ≤ 3.0	10
B105.0012.11.01	12		11				
B105.0016.11.01	16	100	15	16	50	* ≥ 5.0	13

Further sizes upon request

f see inserts type 105

Dimensions in mm

* only valid for standard inserts

Ordering note:

Toolholders can be used with right and left hand inserts.

Spare parts

Toolholder	Chucking nut
B105.0010.9.01	020.0010.1719
B105.001...01	020.0016.1999

TOOLHOLDER Type

BU105

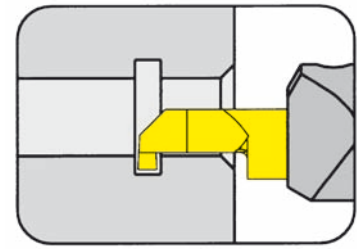

Bore Ø from	.008"
Depth of groove up to	.098"
Width of groove up to	.079"

for use with Insert

Type 105
U105

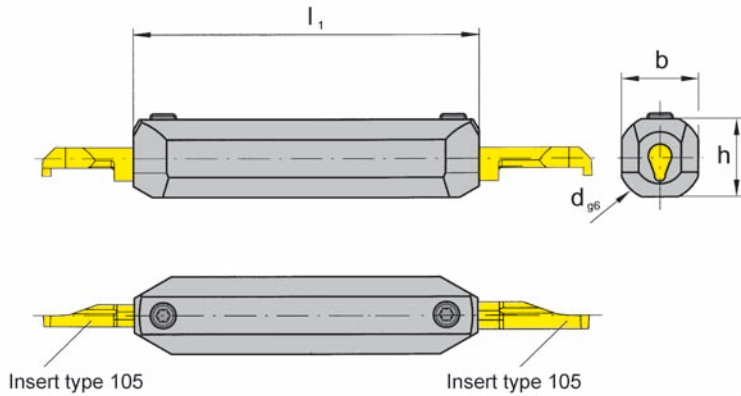

Picture = right and left hand cutting version shown

Part number	d	l ₁	h	b
BU105.0750.2.2.01	.750	4.724	.671	.671

Further sizes upon request

Dimensions in inch

Ordering note:

Toolholders can be used with right and left hand inserts.

Spare parts

Toolholder	Screw	TORX PLUS® Wrench
BU105.0750.2.2.01	6.075T15P	T15PQ

TOOLHOLDER Type

B105

no coolant supply

Bore Ø from	.008" (0.2 mm)
Depth of groove up to	.098" (2.5 mm)
Width of groove up to	.079" (2.0 mm)

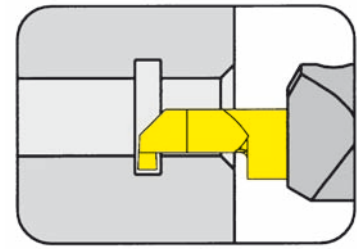

for use with Insert

Type 105
105...2
U105

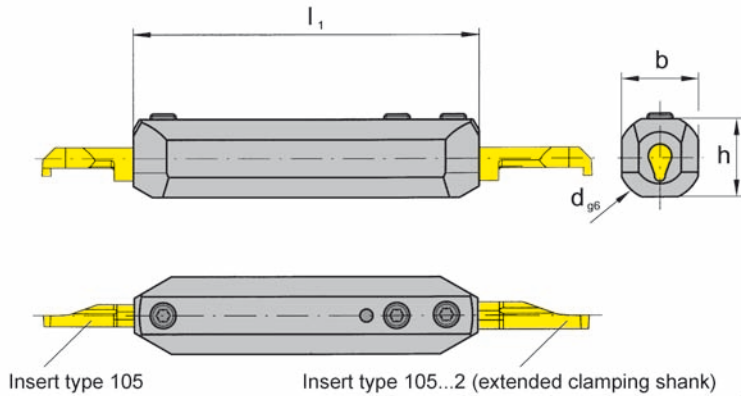

Picture = right and left hand cutting version shown

Part number	d	l ₁	h	b
B105.0020.1.03	20	80	18	18

Further sizes upon request

Dimensions in mm

Ordering note:

Toolholders can be used with right and left hand inserts.

Spare parts

Toolholder	Screw	TORX PLUS® Wrench
B105.0020.1.03	6.075T15P	T15PQ

TOOLHOLDER Type

B105

with through coolant supply

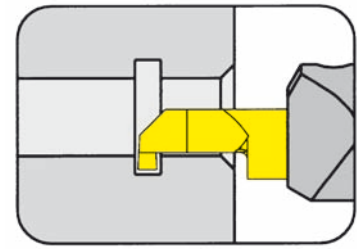

Bore Ø from	.008/.236" (0.2/6.0 mm)
Depth of groove up to	.098/.157" (2.5/4.0 mm)
Width of groove up to	.079/.118" (2.0/3.0 mm)

for use with Insert

Type 105/U105
110/U110

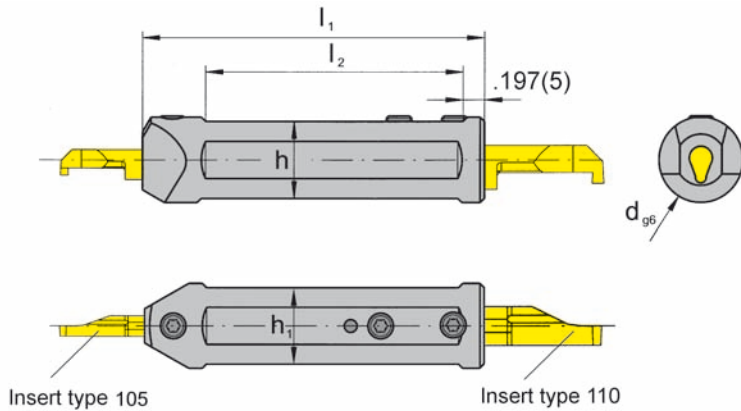

Picture = right and left hand cutting version shown

Part number	d	l ₁	l ₂	h	h ₁
B105.0020.1.10	20	80	60	18	18

Further sizes upon request

Dimensions in mm

Ordering note:

Toolholders can be used with right and left hand inserts.

Spare parts

Toolholder	Screw	TORX PLUS® Wrench
B105.0020.1.10	6.075T15P	T15PQ

SOLUTIONS PLUS Program

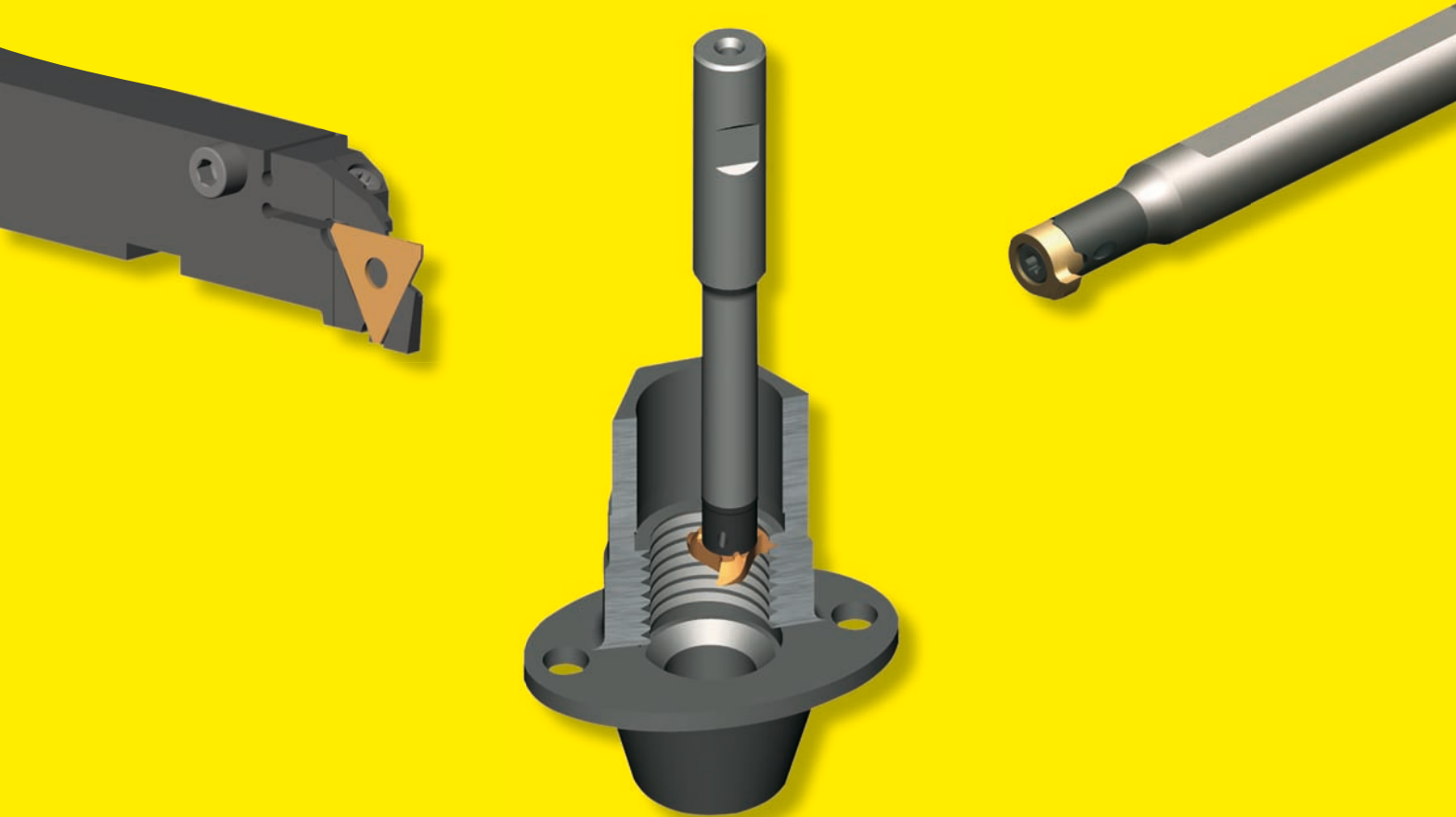

**Need faster delivery?
Inquire about our Solutions Plus Program.**

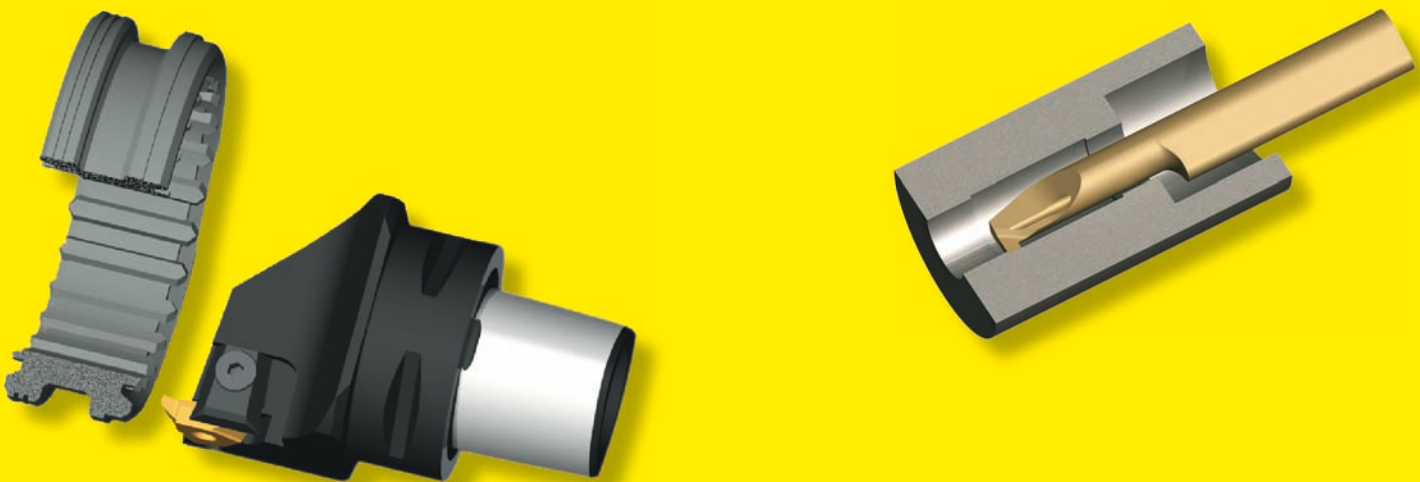

BASIC TOOLHOLDER Type

IR105

with through coolant supply



Bore Ø from

.008" (0.2 mm)

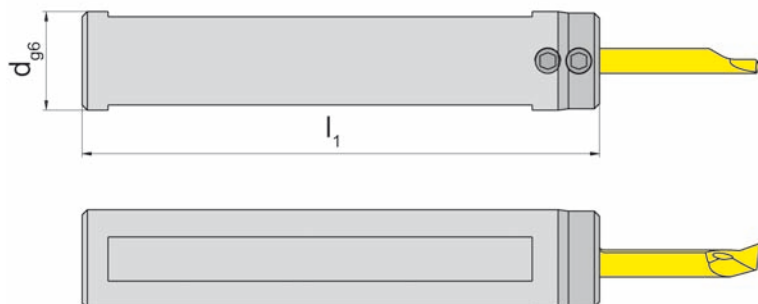

for use with Insert

Type 105
U105

Picture = right hand cutting version shown

Part number	d	l ₁	Type of machine
IR105.34.100	3/4"	100	CITIZEN
IR105.34.40	3/4"	40	
IR105.34.50	3/4"	50	
IR105.34.70	3/4"	70	
IR105.20.30	20,00	30	
IR105.20.50	20,00	50	
IR105.10.100	1"	100	
IR105.10.60	1"	60	STAR
IR105.16.30	16,00	30	
IR105.16.50	16,00	50	
IR105.16.70	16,00	70	
IR105.22.100	22,00	100	
IR105.22.120	22,00	120	
IR105.22.38	22,00	38	
IR105.22.50	22,00	50	TORNOS
IR105.22.70	22,00	70	
IR105.18.310	18,00	310	
IR105.20.170	20,00	170	
IR105.20.185	20,00	185	
IR105.25.100	25,00	100	
IR105.25.150	25,00	150	
IR105.28.80	28,00	80	

Further sizes upon request

Dimensions in mm and inch

Note:

Coolant supply must be ordered separately!

CARTRIDGE Type

IR105

with through coolant supply



Bore Ø from .008" (0.2 mm)

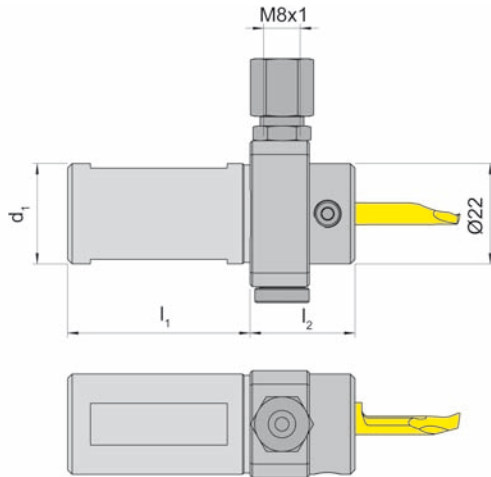

for use with Insert

Type 105
U105

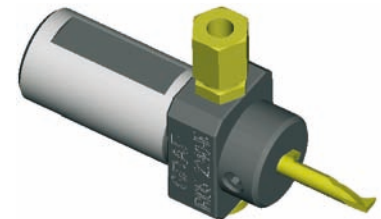

Picture = right hand cutting version shown

Part number	l_1	l_2	d_1
IR105.1640.IKV	40	23	16,00
IR105.3440.IKV	40	23	3/4"
IR105.2040.IKV	40	23	20,00
IR105.2240.IKV	40	23	22,00
IR105.2560.IKV	60	23	25,00
IR105.1060.IKV	60	23	1"

Further sizes upon request

Dimensions in mm and inch

Note:

Coolant supply must be ordered separately!

Spare parts

Cartridge Graf	Screw	TORX PLUS® Wrench
IR105....	6.075T15P	T15PQ

TOOLHOLDER Type

HC105

with screwed clamping

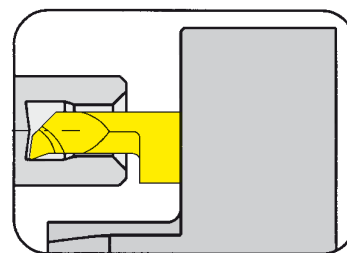

Bore Ø from

.008" (0.2 mm)

Coolant supply through cranked fitting

for use with Insert

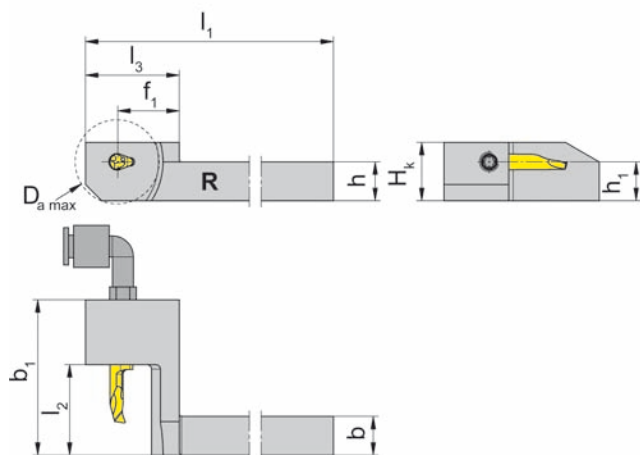
Type 105
U105

L = left hand version shown

R = right hand version

Part number	l_1	l_2	h	h_1	f_1	l_3	b	b_1	$D_{a\ max}$	H_k	Remark
R/LHC105.0707.21	99	18	7	7	19	29	7	32.0	26	13	*
R/LHC105.0808.21	99	18	8	8	19	29	8	32.0	26	13	*
RHC105.1010.11	99	8	10	10	19	29	10	22.7	26	16	*
R/LHC105.1010.21	99	18	10	10	19	29	10	38.0	26	16	
R/LHC105.1010.41	99	28	10	10	19	29	10	48.0	26	16	
R/LHC105.1212.21	99	18	12	12	19	29	12	38.0	26	18	
R/LHC105.1212.41	99	28	12	12	19	29	12	48.0	26	18	
R/LHC105.1616.21	104	18	16	16	24	34	16	38.0	36	22	
R/LHC105.1616.41	104	28	16	16	24	34	16	48.0	36	22	

State R or L version

Dimensions in mm

Further sizes upon request

Note:

* = no through coolant supply!

Spare parts

Toolholder	Screw	TORX PLUS® Wrench	Screwed angle fitting
R/LHC105...07./08...	6.075T15P	T15PQ	-
RHC105...11	6.075T15P	T15PQ	-
R/LHC105.1...21/41	6.075T15P	T15PQ	KQ2L06-M5

TOOLHOLDER Type

HC105

with screwed clamping

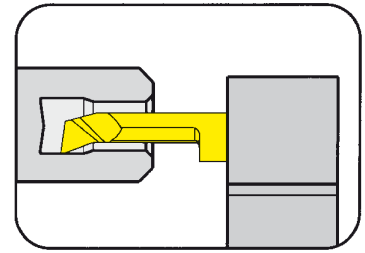

Bore Ø from .008" (0.2 mm)

for use with Insert

Type 105
U105

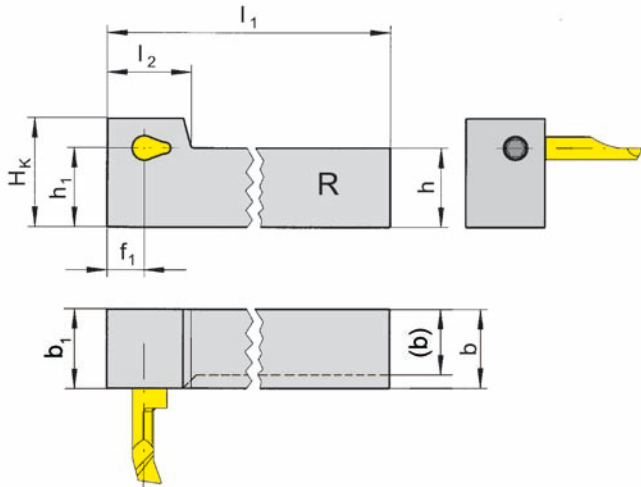

R = right hand version shown

L = left hand version

Part number	l_1	l_2	h	h_1	f_1	b	b_1	H_k
R/LHC105.1212.01	90	17	12	12	7.5	12	16	18
R/LHC105.1616.01	130	17	16	16	7.5	16	16	22

State R or L version

Dimensions in mm

Further sizes upon request

Spare parts

Toolholder	Screw	TORX PLUS® Wrench
R/LHC105.1...	6.075T15P	T15PQ

TOOLHOLDER Type

H105

with screwed clamping

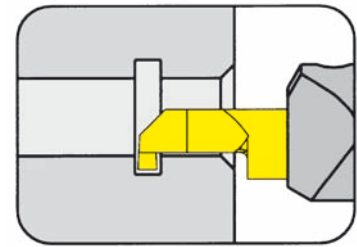

Bore Ø from

.008" (0.2 mm)

for use with Insert

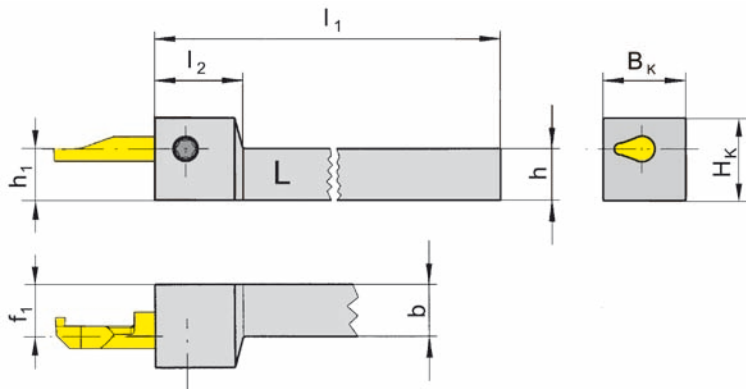
Type 105
U105

L = left hand version shown

R = right hand version

Part number	l_1	l_2	h	h_1	f_1	b	B_K	H_K
R/LH105.0808.01	90	17	8	8	7.5	8	16	14
R/LH105.1010.01	90	17	10	10	7.5	10	16	16
R/LH105.1212.01	90	17	12	12	7.5	12	16	18
R/LH105.1616.01	110	17	16	16	7.5	16	16	22

State R or L version

Dimensions in mm

Further sizes upon request

Spare parts

Toolholder	Screw	TORX PLUS® Wrench
R/LH105....	6.075T15P	T15PQ

HORN - THE LEADERS IN GROOVING TECHNOLOGY



High Performance Reaming

SYSTEM DR
URMA Licence

Large selection of base material, coatings and geometries.
High repeatability when replacing inserts.
Diameters from 11.9 mm - 140.6 mm.

HORN - INTELLIGENT TOOL DESIGN AT WORK.



For further information, please contact HORN USA.

TOOLHOLDER Type

962

with screwed clamping

Bore Ø from .008" (0.2 mm)

Coolant through fitting

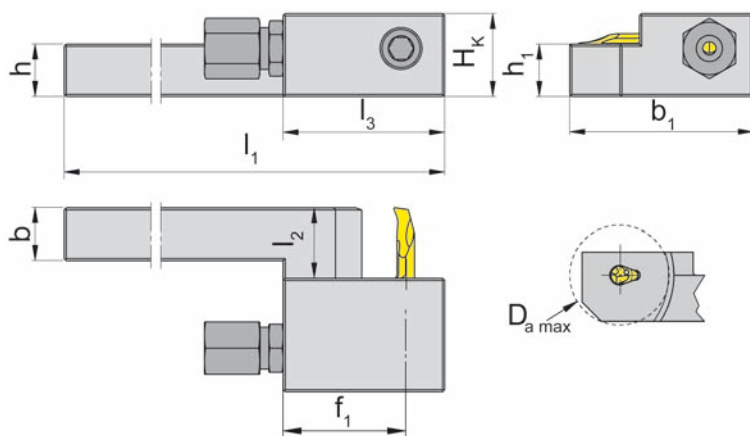

for use with Insert

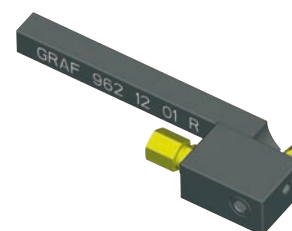
Type 105
U105

R = right hand version shown

L = left hand version

Part number	l_1	l_2	h	h_1	f_1	l_3	b	b_1	$D_{a \max}$	H_k
962.08.01R 962.08.02L	130	15	8	8	27	37	8	42	26	15
962.10.01R 962.10.02L	130	15	10	10	27	37	10	42	26	17
962.12.01R 962.12.02L	130	15	12	12	27	37	12	42	26	19
962.16.01R 962.16.02L	130	15	16	16	27	37	16	42	32	23
962.20.01R 962.20.02L	130	15	20	20	27	37	20	42	32	27

Further sizes upon request

Dimensions in mm

Note:

Coolant supply must be ordered separately!

Spare parts

Toolholder	Screw	TORX PLUS® Wrench	Coolant supply
962....	6.075T15P	T15PQ	004.00.19

TOOLHOLDER Type

962

with screwed clamping



Bore Ø from .008" (0.2 mm)

Coolant through fitting

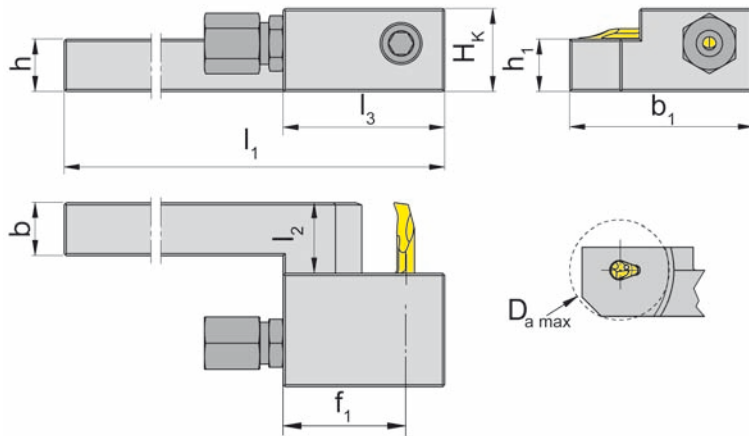

for use with Insert

Type 105
U105

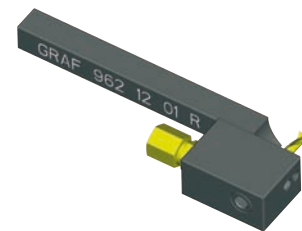

R = right hand version shown

L = left hand version

Part number	l_1	l_2	h	h_1	f_1	l_3	b	b_1	$D_{a \max}$	H_k
962.08.03R 962.08.04L	130	30	8	8	27	37	8	57	26	15
962.10.03R 962.10.04L	130	30	10	10	27	37	10	57	26	17
962.12.03R 962.12.04L	130	30	12	12	27	37	12	57	26	19
962.16.03R 962.16.04L	130	30	16	16	27	37	16	57	32	23
962.20.03R 962.20.04L	130	30	20	20	27	37	20	57	32	27

Further sizes upon request

Dimensions in mm

Note:

Coolant supply must be ordered separately!

Spare parts

Toolholder	Screw	TORX PLUS® Wrench	Coolant supply
962....	6.075T15P	T15PQ	004.00.19

TOOLHOLDER Type

963

with screwed clamping

Bore Ø from .008" (0.2 mm)

Coolant through fitting

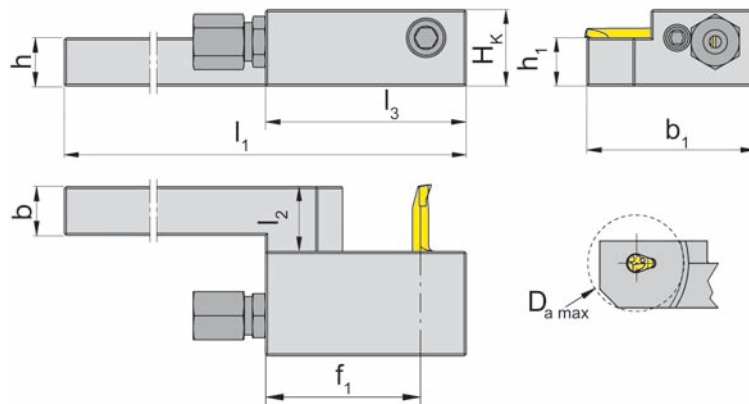

for use with Insert

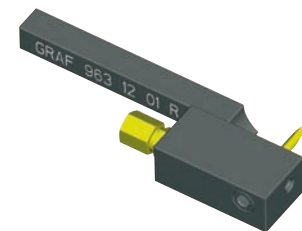
Type 105
U105

R = right hand version shown

L = left hand version

Part number	l_1	l_2	h	h_1	f_1	l_3	b	b_1	$D_{a \max}$	H_k
963.08.01R 963.08.02L	130	15	8	8	40	50	8	42	26	15
963.10.01R 963.10.02L	130	15	10	10	40	50	10	42	26	17
963.12.01R 963.12.02L	130	15	12	12	40	50	12	42	26	19
963.16.01R 963.16.02L	130	15	16	16	45	50	16	42	32	23
963.20.01R 963.20.02L	130	15	20	20	45	50	20	42	32	27

Further sizes upon request

Dimensions in mm

Note:

Coolant supply must be ordered separately!

Spare parts

Toolholder	Screw	TORX PLUS® Wrench	Coolant supply
963....	6.075T15P	T15PQ	004.00.19

TOOLHOLDER Type

AIH



Bore Ø from .008" (0.2 mm)

for use with Insert

Type 105
U105
S274

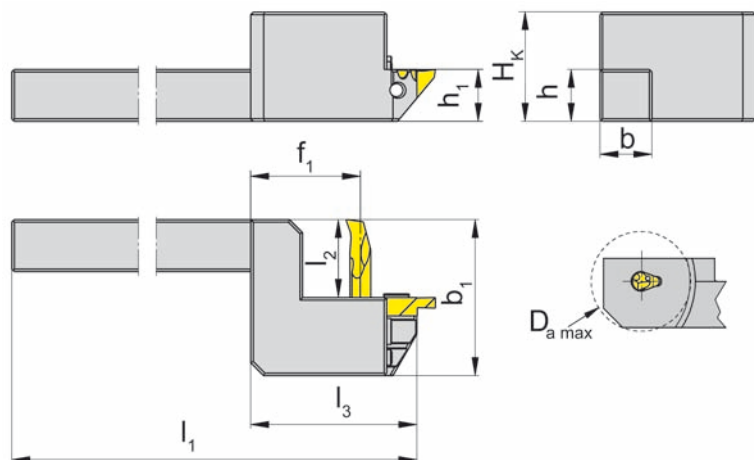

R = right hand version shown

L = left hand version

Part number	l_1	l_2	h	h_1	f_1	l_3	b	b_1	$D_{a \max}$	H_k	Remark
AIH.974.R/L1010.K04			10	10	23	35	10		20	17	
AIH.974.R/L1212.K04	130	15	12	12	23	35	12	30	20	19	*
AIH.974.R/L1616.K04			16	16	26	38	16		26	23	
AIH.974.R/L2020.K04			20	20	29	38	20		32	23	
AIH.R/L1010.K08			10	10	21		10		20	17	
AIH.R/L1212.K08	130	15	12	12	21	30	12	30	20	19	**
AIH.R/L1616.K08			16	16	24		16		26	23	
AIH.R/L2020.K08			20	20	27		20		32	23	

State R or L version

Dimensions in mm

Note:

* These toolholders can be equipped with HORN inserts type 105 and S274

** These toolholders can be equipped with HORN inserts type 105 and Graf inserts CS08

Further sizes upon request

Spare parts

Toolholder	Screw	Screw	TORX PLUS® Wrench
AIH....	030.3509.T15P	6.075T15P	T15PQ

Tools for Tornos DECO2000

for Insert

- Type 105

Bore Ø from .008" (0.2 mm)

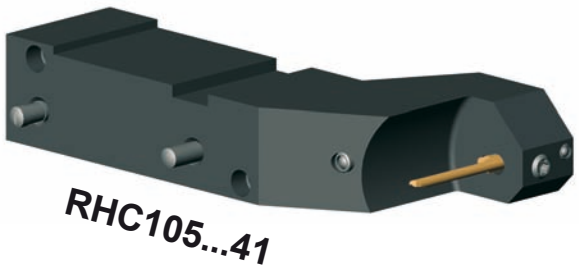
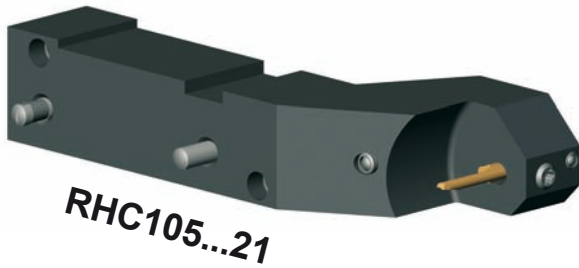

Basic toolholder	Insert	Machine
RHC105.0710.21	105...21 l ₂ up to .591" (15 mm)	DECO7/10
RHC105.0710.41	105...41 l ₂ up to .984" (25 mm)	

Dimensions in inch (mm)

Tools for Tornos DECO2000

for Cassettes

- Type RKC760

Bore Ø from .008" (0.2 mm)

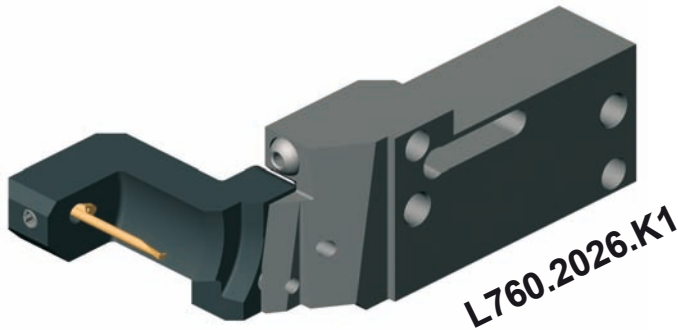
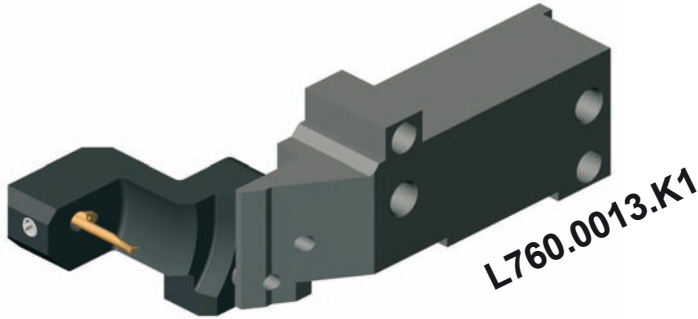

Basic toolholder	Cassette	Insert	Machine
L760.0013.K1	RKC760.0105.21	105...21 l ₂ up to .591" (15 mm)	DECO13
L760.2026.K1	RKC760.0105.41	105...41 l ₂ up to .984" (25 mm)	DECO20/26

Dimensions in inch (mm)

BASIC TOOLHOLDER Type

BGT

without cartridge

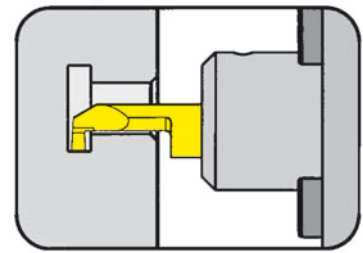

Adjustable round shanks for toolholder BKT105.2445.01/2

with through coolant supply

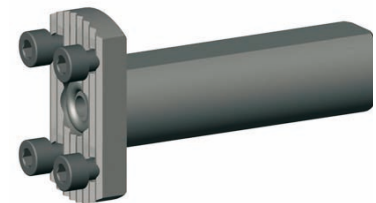
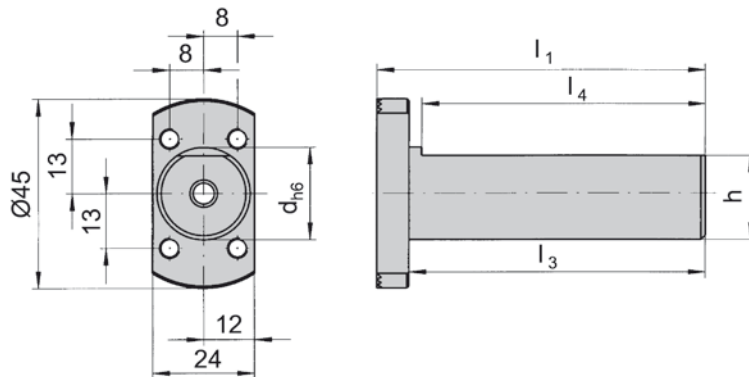

Part number	d	l_1	h	l_3	l_4	Machine tool
BGT001.0010.50	10	57.50	9	50	47	
BGT001.0016.21 BGT001.0R16.21	16	28.50	14	21	18	Star
BGT001.0020.100	20	107.50	18	100	97	Tornos
BGT001.0022.30 BGT001.0022.70	22	36.35 77.50	20	30 70	27 67	Star
BGT001.0025.70	25	77.50	23	70	67	
BGT001.0028.80	28	87.50	26	81	77	Traub

Further sizes upon request

Dimensions in mm

Note:

BGT001.0022.30 without through coolant supply

Spare parts

Basic toolholder	Screw	O-ring
BGT001.0...	DIN912M5X10	DIN37707X3

ADJUSTABLE HOLDER Type **BKT**

Bore Ø from	.008" (0.2 mm)
Depth of groove up to	.098" (2.5 mm)
Width of groove up to	.079" (2.0 mm)

with through coolant supply

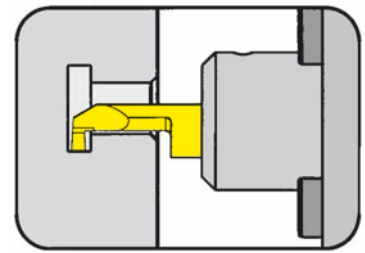

for use with Insert

Type 105
U105

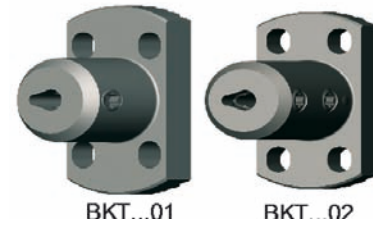
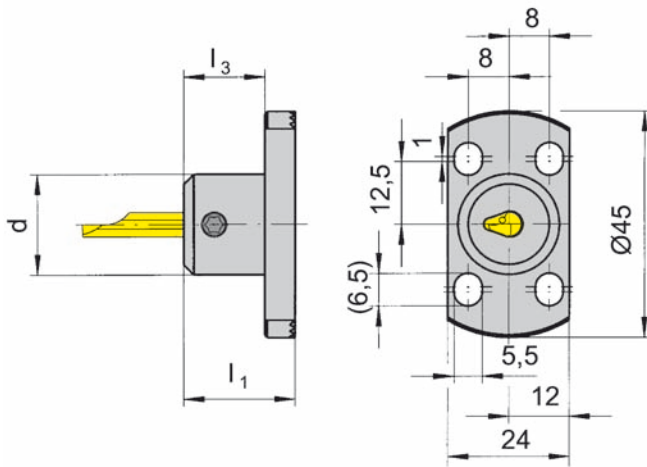

Part number	d	l ₁	l ₃
BKT105.2445.01	20	22	16
BKT105.2445.02		32	26

Further sizes upon request

Dimensions in mm

Spare parts

Adjustable holder	Screw	TORX PLUS® Wrench
BKT105.2445.0...	6.075T15P	T15PQ

BASIC TOOLHOLDER Type

BGT

without cartridge

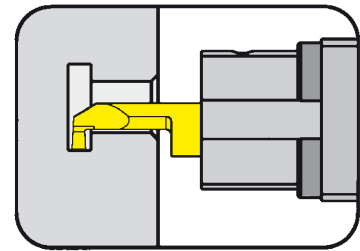

Adjustable round shanks for toolholder BKT105.2327.01

with through coolant supply

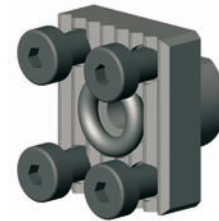
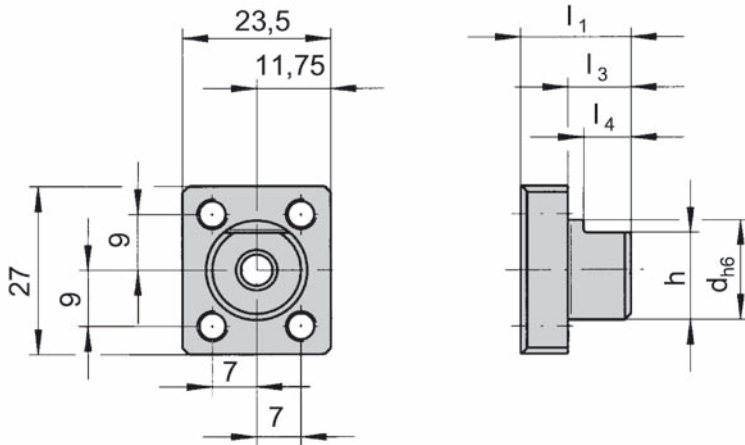

Part number	d	l ₁	h	l ₃	l ₄	Machine tool
BGT001.1627.10	16	17.5	14	10	7.5	Star

Further sizes upon request

Dimensions in mm

Spare parts

Basic toolholder	Screw	O-ring
BGT001.1627.10	DIN912M5X10	DIN37707X3

BASIC TOOLHOLDER Type

BGT

without cartridge

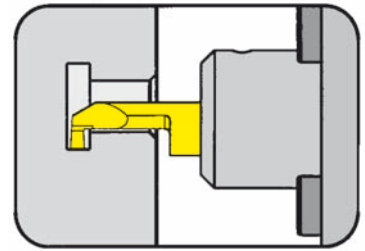

Adjustable round shanks for toolholder BKT105.2327.01

with through coolant supply

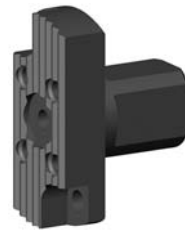
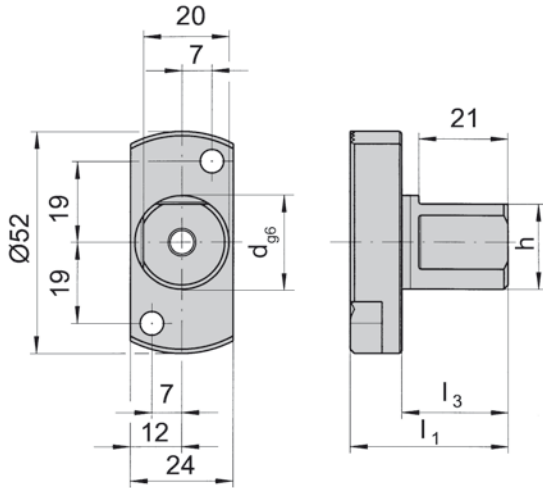

Part number	d	l ₁	h	l ₃
BGT001.0R22.25	22	37	20	25

Further sizes upon request

Dimensions in mm

Spare parts

Basic toolholder	Screw
BGT001.0R22.25	DIN912M5X10

ADJUSTABLE HOLDER Type **BKT**

Bore Ø from	.008" (0.2 mm)
Depth of groove up to	.098" (2.5 mm)
Width of groove up to	.079" (2.0 mm)

with through coolant supply

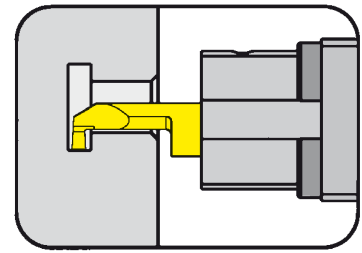

for use with Insert

Type 105
U105

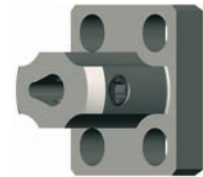
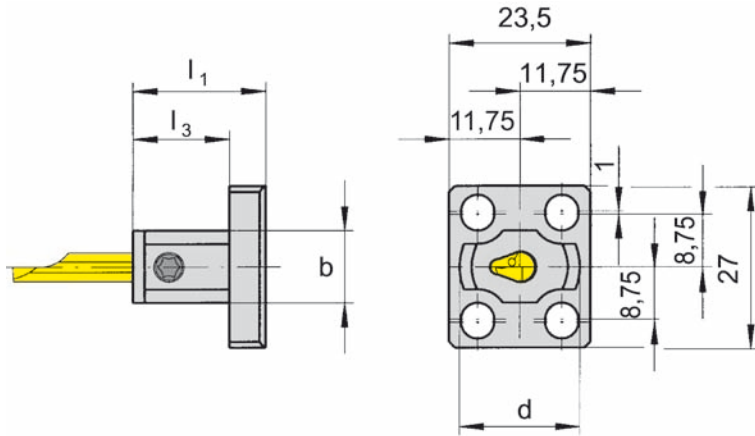

BKT105.2327.01

Part number	d	l ₁	l ₃	b
BKT105.2327.01	20	22	16	12

Further sizes upon request

Dimensions in mm

Spare parts

Adjustable holder	Screw	TORX PLUS® Wrench
BKT105.2327.01	6.075T15P	T15PQ

TOOLHOLDER Type

B105

with through coolant supply

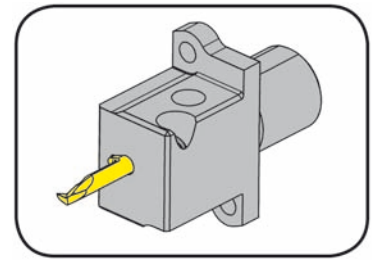

Bore Ø from	.008" (0.2 mm)
Depth of groove up to	.098" (2.5 mm)
Width of groove up to	.079" (2.0 mm)

Through coolant supply G1/8"

for use with Insert

Type 105
U105

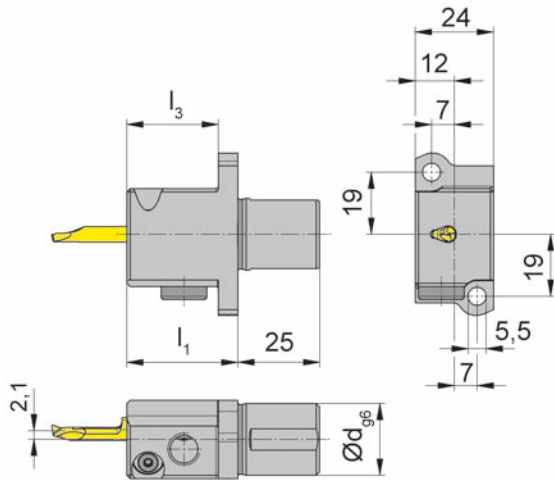

L = left hand version

Star SV 12/20/32
SR 10/20/32 and SB 16

Part number	d	l ₁	l ₃
LB105.A022.26.31	22	34	28

Further sizes upon request

Dimensions in mm

Spare parts

Toolholder	Screw	TORX PLUS® Wrench
LB105.A022.26.31	6.075T15P	T15PQ

BASIC TOOLHOLDER Type

G

without cartridge

for adjustable holder Graf type N and HORN
BKT105.2445.01/2

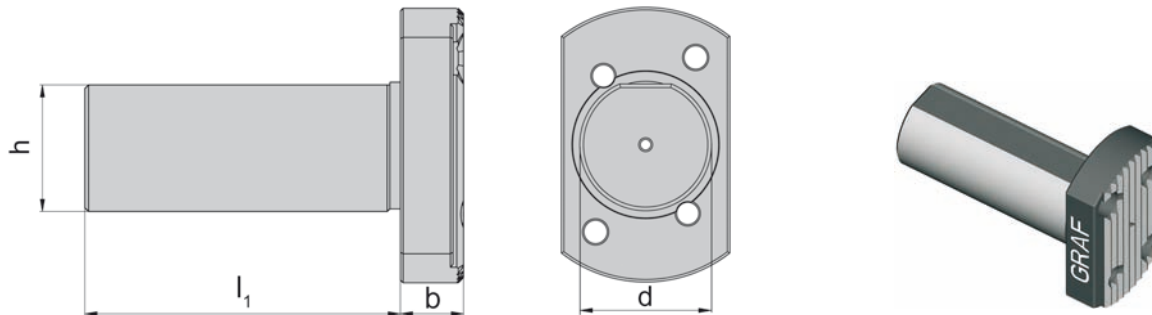

Part number	d	l ₁	h	b	Machine tool
G016021 G016040	16,00	21 40	14	6	Star Traub/Manurhin
G034040 G034050 G034120	3/4"	40 50 120	18	6	Citizen
G020030 G020040 G020100 G020150	20,00	30 40 100 150	18	6	Citizen Hanwha Tornos Manurhin/Tornos
G022023 G022025SR16/20R G022030 G022030SR32 G022070	22,00	23 25 30 30 70	20	6 12 6 12 6	Star

Further sizes upon request

Dimensions in mm and inch

BASIC TOOLHOLDER Type

G

without cartridge



for adjustable holder Graf type N and HORN
BKT105.2445.01/2

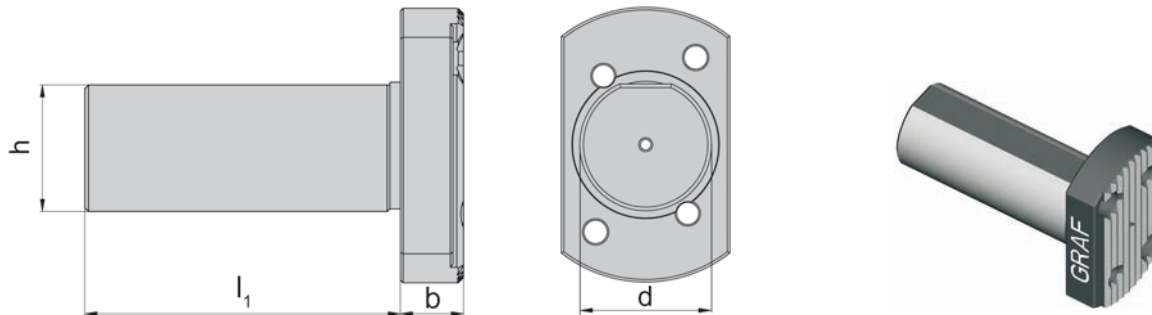

Part number	d	l ₁	h	b	Machine tool
G025060	25,0	60	23	12	Hanwha
G025070		70		6	Manurhin/Tornos
G025100		100		6	Manurhin/Tornos
G025160		160		6	Manurhin/Tornos
G010060	1"	60	23	6	Citizen
G010100		100			
G028006	28,0	6	26	12	Hanwha
G028080		80			Traub
G030045	30,0	45	27	12	Maier
G033040	33,0	40	31	12	Hanwha
G034020	34,0	20	32	12	Maier
G034044		44			Maier/Hanwha

Further sizes upon request

Dimensions in mm and inch

ADAPTOR Type

Z

without cartridge



for adjustable holder Graf type N and HORN
BKT105.2445.01/2

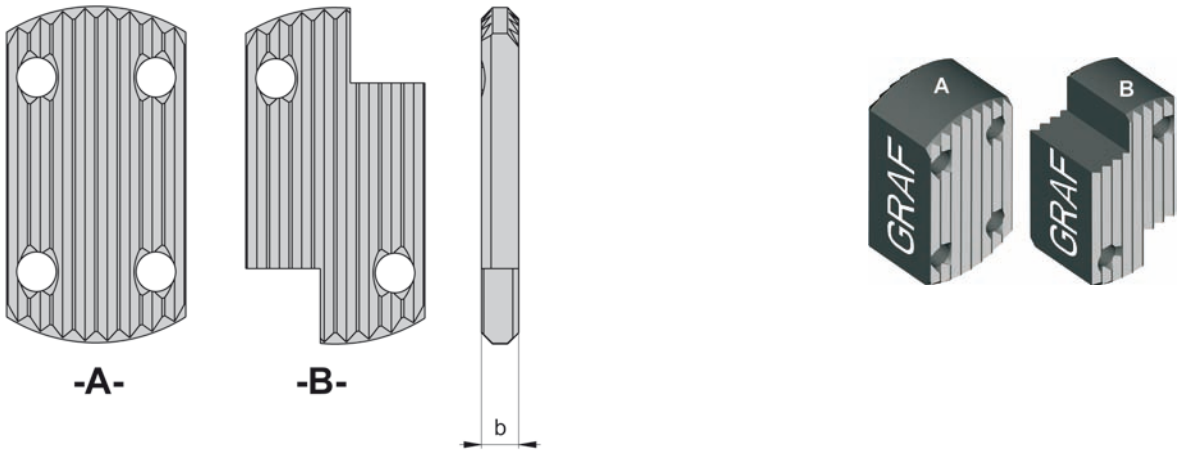

Part number	b	Form
Z5	5	A
Z10	10	
Z15	15	
Z20	20	
Z25	25	
Z30	30	
Z5SR16/20R	5	B
Z10SR16/20R	10	
Z15SR16/20R	15	
Z20SR16/20R	20	
Z25SR16/20R	25	
Z30SR16/20R	30	

Further sizes upon request

Dimensions in mm

ADAPTOR Type

Z

without cartridge

for adjustable holder HORN BKT.105.2327.01

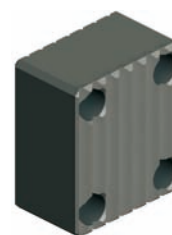
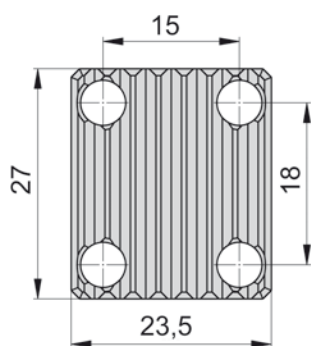

Part number	b
Z10SW7	10
Z15SW7	15
Z20SW7	20
Z25SW7	25
Z30SW7	30

Further sizes upon request

Dimensions in mm

ADAPTOR Type

N

without Cartridge



for adjustable holder Graf type N and HORN BKT105.2445.01/2

for back working

Part number N11

For alternatively 2 cartridges

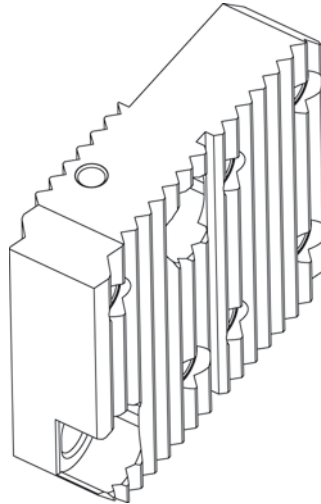
**Part number N12**

For alternatively 3 cartridges

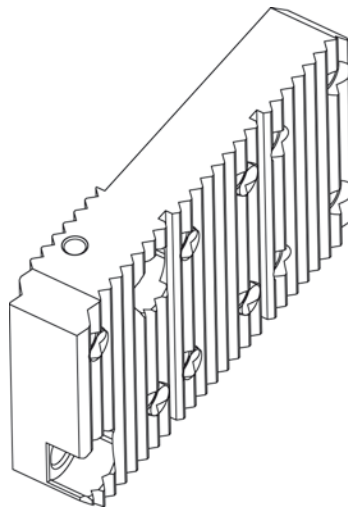
**Part number N93IK**

with through coolant supply

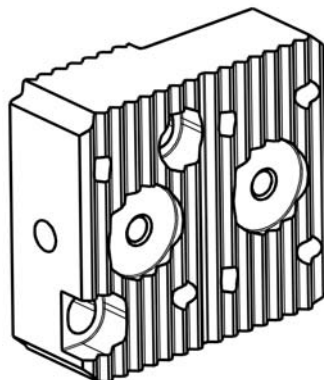

DEVICE FOR HEIGHT ADJUSTING Type **HVR40**



for back working holder HVR40

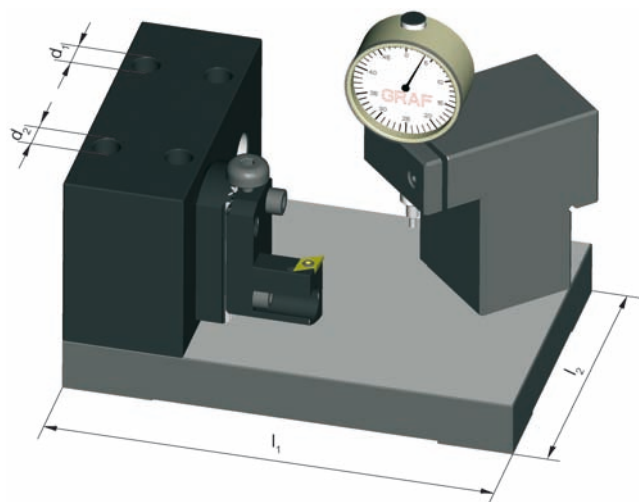

Part number	d ₁	d ₂	l ₁	l ₂	System
12.0506	16	22	250	180	STAR
12.0507	3/4"	1"			CITIZEN
12.0508	30	34			MAIER
12.0511	25	33			HANWHA
12.0523	20	28			HANWHA

Dimensions in mm and inch

ADJUSTABLE HOLDER Type

N

Bore Ø from	.008" (0.2 mm)
Depth of groove up to	.098" (2.5 mm)
Width of groove up to	.079" (2.0 mm)

with through coolant supply

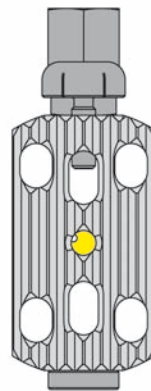
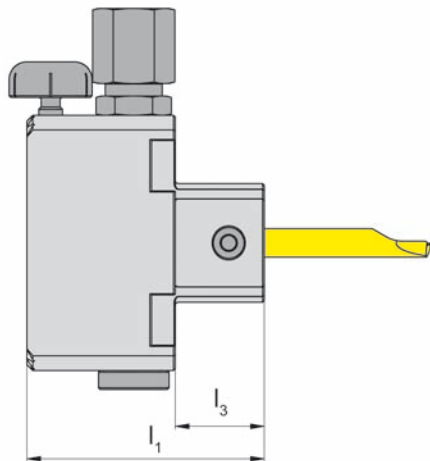

for use with Insert

Type 105
U105

Picture = right hand cutting version shown

Part number	l_1	l_3
N09IK	40	15

Further sizes upon request

Dimensions in mm

Spare parts

Adjustable holder	Screw	Height adjustment screw	Coolant supply
N09IK	6.075T15P	002.00.69	004.00.19

A40

ADJUSTABLE HOLDER Type **N**



Bore Ø from	.008" (0.2 mm)
Depth of groove up to	.098" (2.5 mm)
Width of groove up to	.079" (2.0 mm)

no through coolant supply

for use with Insert

Type 105
U105

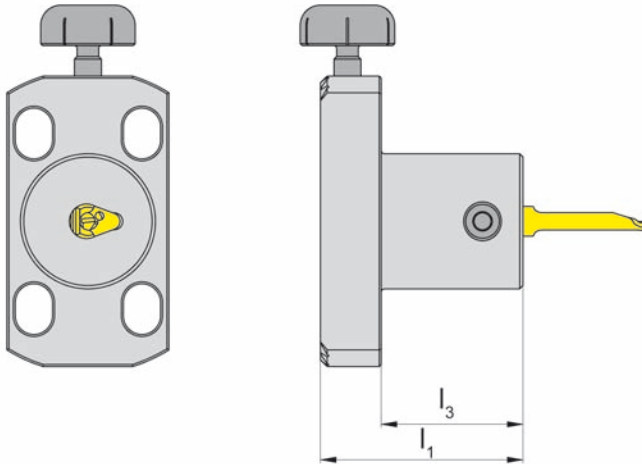

Picture = right hand cutting version shown

Part number	l_1	l_3
N09	30	20

Further sizes upon request

Dimensions in mm

Spare parts

Adjustable holder	Screw	Height adjustment screw
N09	6.075T15P	002.00.69

ADJUSTABLE HOLDER Type **N**



Bore Ø from	.008" (0.2 mm)
Depth of groove up to	.098" (2.5 mm)
Width of groove up to	.079" (2.0 mm)

with through coolant supply

for use with Insert

Type 105
U105

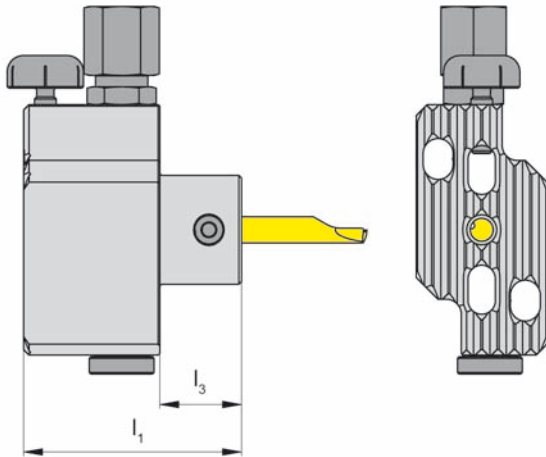

Picture = right hand cutting version shown

Part number	l_1	l_3
N73IK	40	15

Further sizes upon request

Dimensions in mm

Spare parts

Adjustable holder	Screw	Height adjustment screw	Coolant supply
N73IK	6.075T15P	002.00.69	004.00.19

ADJUSTABLE HOLDER Type **N**



Bore Ø from	.008" (0.2 mm)
Depth of groove up to	.098" (2.5 mm)
Width of groove up to	.079" (2.0 mm)

no through coolant supply

for use with Insert

Type 105
U105

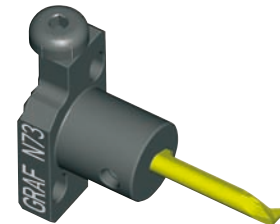
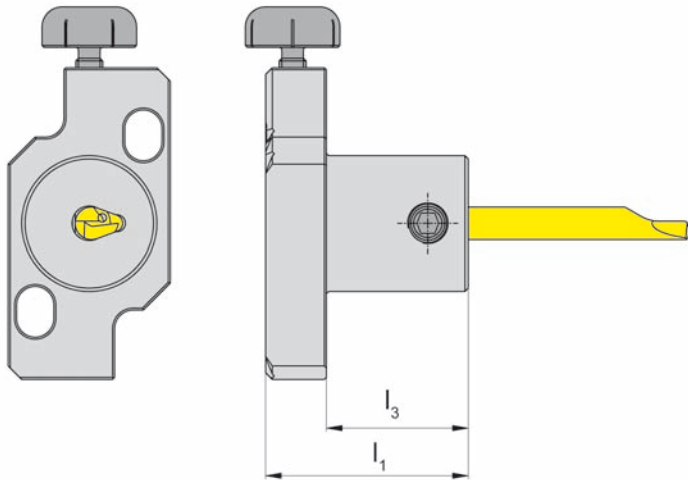

Picture = right hand cutting version shown

Part number	l_1	l_3
N73	30	20

Further sizes upon request

Dimensions in mm

Spare parts

Adjustable holder	Screw	Height adjustment screw
N73	6.075T15P	002.00.69

Standard connection for through cooling

for pipe Ø 6 mm

Connection for through cooling
004.00.19

M8 x 1



for pipe Ø 6 mm

Connection for through cooling
004.00.22



M8 x 1

Clip connection for through cooling

M10 x 1

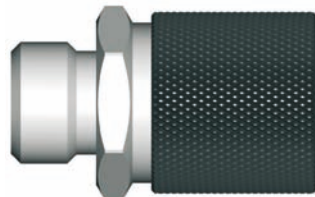

Clip connection

004.00.49

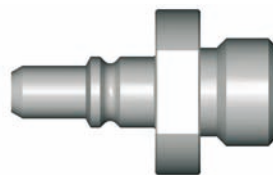

Plug

M8 x 1 - 004.00.56

G1/8" - 004.00.57

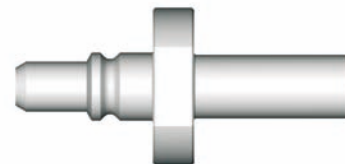

Plug

Ø 6 mm - 004.00.59

for pipe Ø 6 mm

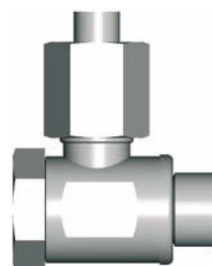

Coupling

M8 x 1 - 004.00.61

G1/8" - 004.00.16

Polygon cutter

For use on lathes with ability to machine polygon profiles

For further information, please see HORN catalog "CARBIDE MILLING TOOLS".

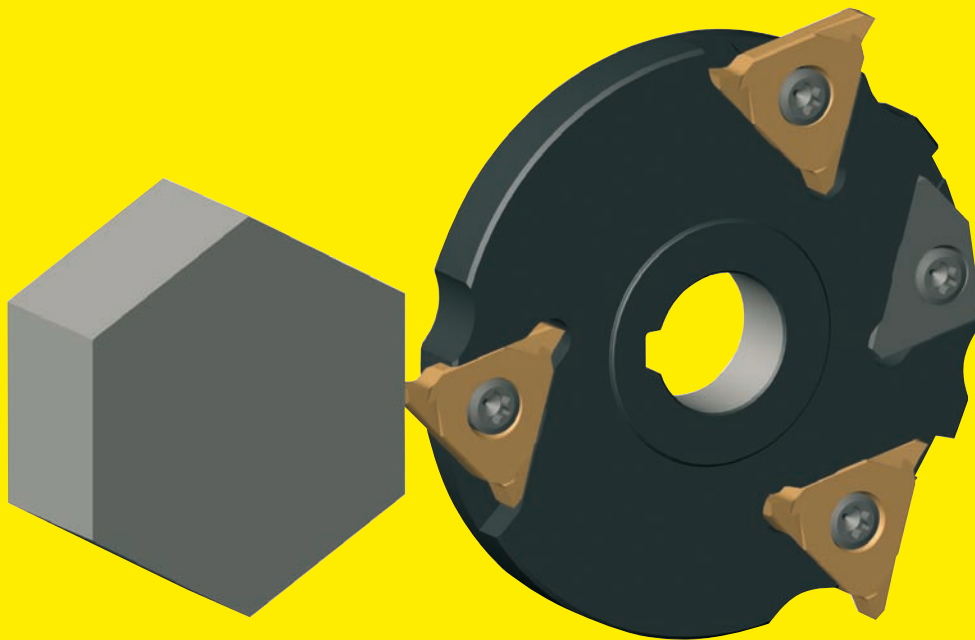

TOOLHOLDER Type

VDI

with through coolant supply

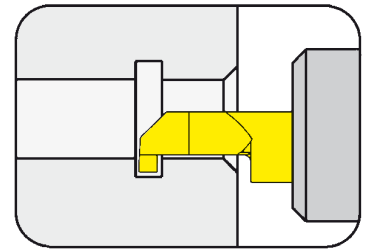

Bore Ø from

.008" (0.2 mm)

for use with Insert

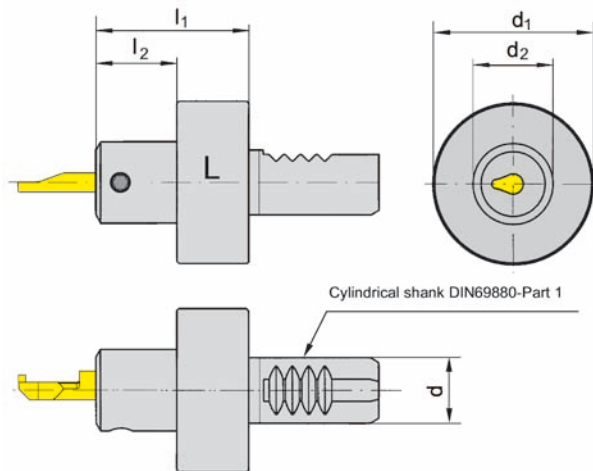
Type 105
U105

L = left hand version shown

R = right hand version

Part number	d	l_1	l_2	d_2	d_1
VDI16.R/L105.20.01	16	38	20	20	40
VDI20.R/L105.20.01	20	38	20	20	50
VDI25.R/L105.20.01	25	38	20	20	58
VDI30.R/L105.20.01	30	38	20	20	68
VDI40.R/L105.20.01	40	38	20	20	83

State R or L version

Dimensions in mm

Further sizes upon request

Spare parts

Toolholder	Screw	TORX PLUS® Wrench
VDI...	6.075T15P	T15PQ

TOOLHOLDER Type

B105C

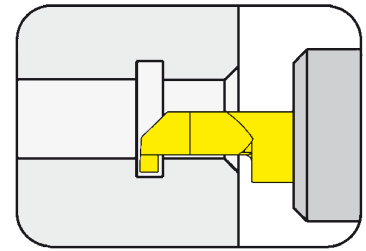

Adapter for inserts type 105 HORN-Capto

for use with Insert

Type 105
U105

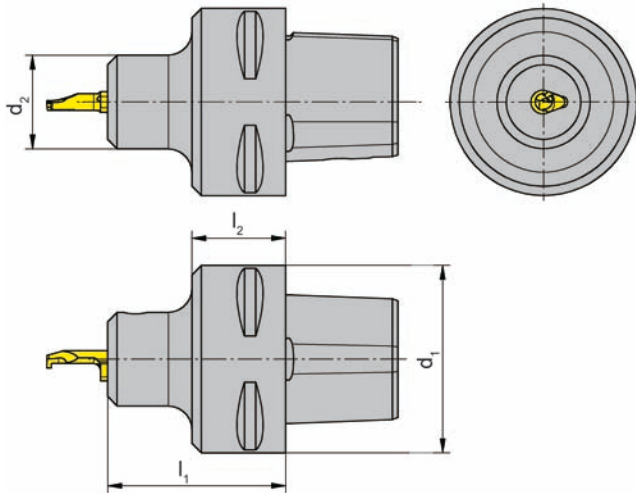

R = right hand version shown

L = left hand version

Licence Sandvik

Part number	l_1	l_2	d_2	d_1	Remark
R/LB105.00C3.20.1.01	30	15	20	32	C3
R/LB105.00C4.20.1.01	38	20		40	C4
R/LB105.00C5.20.1.01	38	20		50	C5
R/LB105.00C6.20.1.01	42	22		63	C6

State R or L version

Dimensions in mm

Further sizes upon request

Spare parts

Toolholder	Screw	TORX PLUS® Wrench
R/LB105.00C...	6.075T15P	T15PQ

TOOLHOLDER Type

B105C

Adapter for inserts type 105 HORN-Capto

for INDEX Multi spindle machines

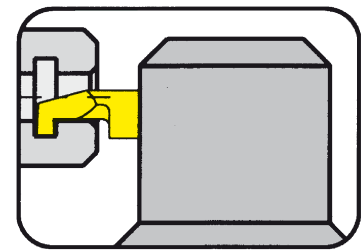

for use with Insert

Type 105
U105

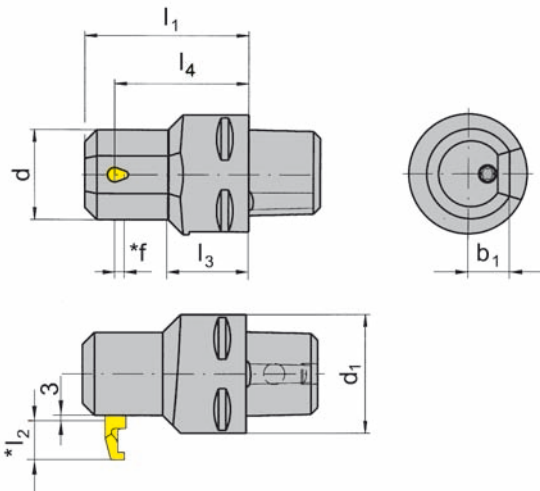

Picture = right hand cutting version shown

Licence Sandvik

Part number	d	l ₁	l ₃	b ₁	l ₄	d ₁	Type of machine
RB105.00C3.2.2.01	30	55	17	14	45	32	MS32
RB105.00C3.2.2.02	36		15	18			
RB105.00C4.2.2.01	30	55	26	14	45	40	MS52
RB105.00C4.2.2.02	36		22	18			

Further sizes upon request

f, l₂ see inserts type 105

Dimensions in mm

Spare parts

Toolholder	Screw	TORX PLUS® Wrench
RB105.00C...	6.075T15P	T15PQ



Supermini® 105 from Ø .008" (0.2 mm)
MINI 108 from Ø.315" (8.0 mm)
Grooving system 264



External and internal machining
- not only for Swiss Type Machines -

BASIC TOOLHOLDER Type

KM16

Basic toolholder for use with toolholder ...KM16...

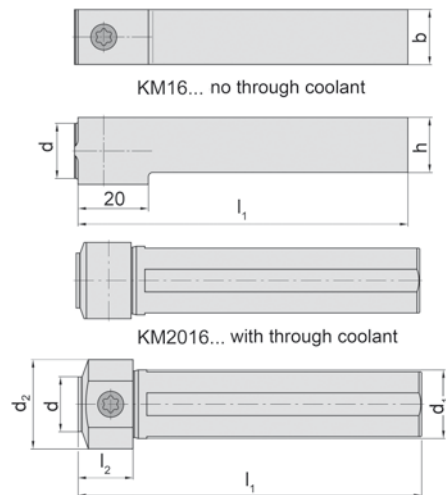
System Kennametal
KM16 Micro

Part number	d	d ₁	d ₂	l ₁	l ₂	h	b
KM16 NCM 1616 100	16	-	-	100	-	16	16
KM2016 NCM SS20 16	20	20	26	100	16	-	-
KM2016 NCM SS22 16	20	22	28	100	16	-	-

Dimensions in mm

Spare parts

Basic toolholder	Screw	TORX PLUS® Blade
KM16 NCM 1616 100 KM2016 NCM SS2...	KM16-NSPKG KM16-NAPKG	DT27PQ DT27PQ

FLANGE Type

KM16



Basic toolholder for use with toolholder ...KM16...

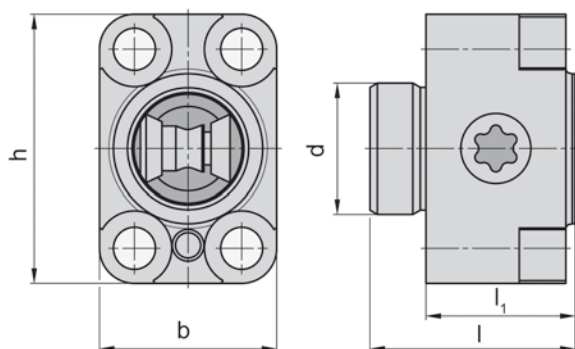

KM16... no through coolant supply

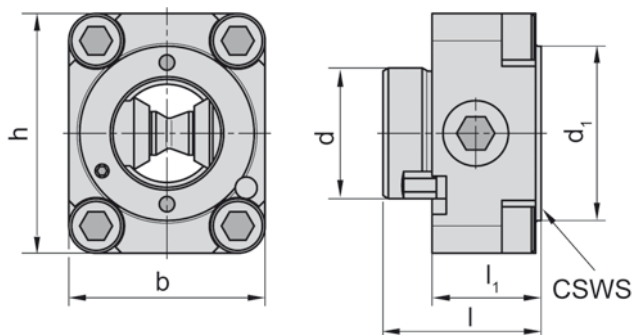

KM2016... with through coolant supply

System Kennametal
KM16 Micro

Part number	l	d	d ₁	l ₁	h	b
KM16NCMSF1928	22	14	-	16	27.5	19
KM2016NCMSF2434	22	20	20	16	33.0	25

Spare parts

Flange	Screw	TORX PLUS® Blade
KM16NCMSF1928 KM2016NCMSF2434	KM16-NSPKG KM16-NAPKG	DT27PQ DT27PQ

TOOLHOLDER Type

B105KM

with through coolant supply

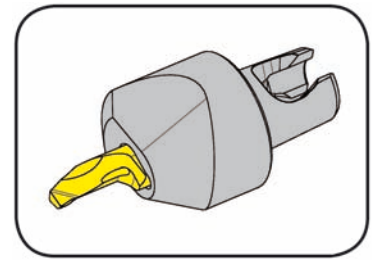

Bore Ø from .008" (0.2 mm)

for use with Insert

Type 105
U105

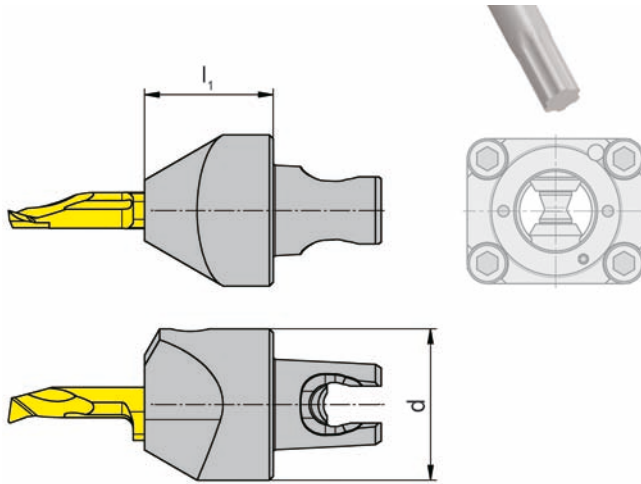

Picture = right hand cutting version shown

System Kennametal
KM16 Micro

Part number	d	l ₁
B105.KM16.90.01	20	17

Further sizes upon request

Dimensions in mm

Spare parts

Toolholder	Screw	TORX PLUS® Wrench
B105.KM16.90.01	6.075T15P	T15PQ

TOOLHOLDER Type

B105KM

with through coolant supply

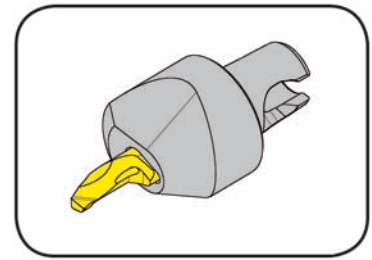

Bore Ø from .008" (0.2 mm)

for use with Insert

Type 105
U105

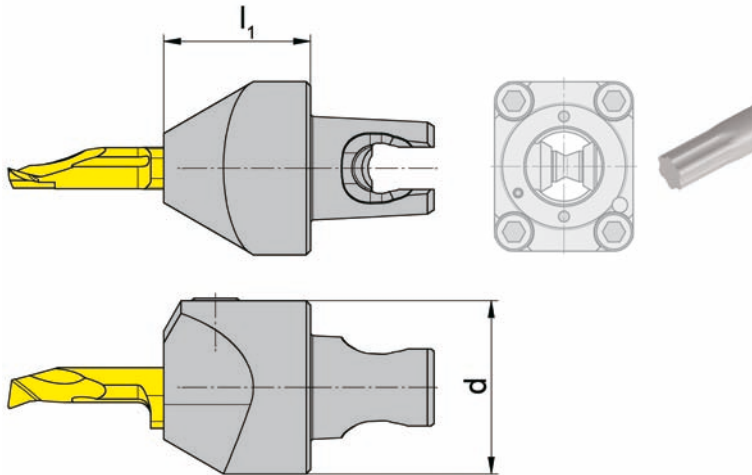

Picture = right hand cutting version shown

System Kennametal
KM16 Micro

Part number	d	l ₁
B105.KM16.01	20	17

Further sizes upon request

Dimensions in mm

Spare parts

Toolholder	Screw	TORX PLUS® Wrench
B105.KM16.01	6.075T15P	T15PQ

TOOLHOLDER Type

B105KM

with through coolant supply

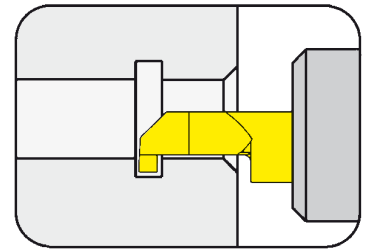

Adapter for inserts type 105 System KM

for use with Insert

Type 105
U105

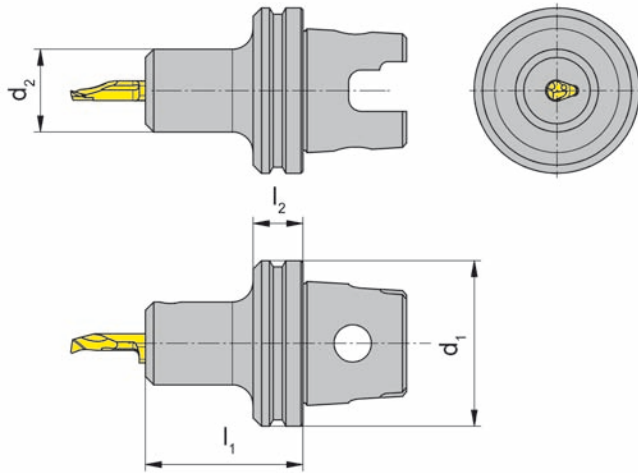

R = right hand version shown

L = left hand version

KM-System

Part number	l_1	l_2	d_2	d_1	Remark
R/LB105.KM40.20.1.01	38	12	20	40	KM40

State R or L version

Dimensions in mm

Further sizes upon request

Spare parts

Toolholder	Screw	TORX PLUS® Wrench
R/LB105.KM40.20.1.01	6.075T15P	T15PQ

TOOLHOLDER Type

B105KM

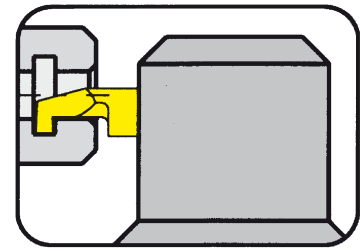

Adapter for inserts type 105 HORN-KM

for INDEX Multi spindle machines

for use with Insert

Type 105
U105

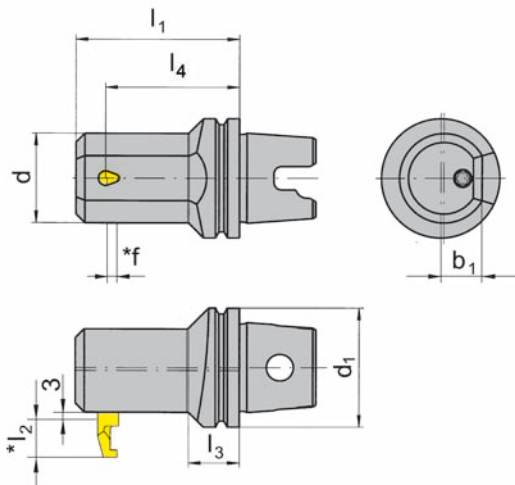

Picture = right hand cutting version shown

Licence Kennametal

Part number	d	l ₁	l ₃	b ₁	l ₄	d ₁	Type of machine
RB105.KM40.2.2.01 RB105.KM40.2.2.02	36	55	17 14	14 18	45	40	MS32
RB105.KM50.2.2.01 RB105.KM50.2.2.02	36	55	26 22	14 18	45	50	MS52

Further sizes upon request

f, l₂ see inserts type 105

Dimensions in mm

Spare parts

Toolholder	Screw	TORX PLUS® Wrench
RB105.KM...	6.075T15P	T15PQ

INSERT Type

105

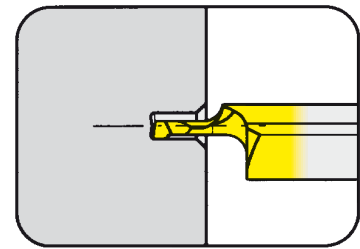

Bore Ø from .008''

for use with Toolholder

- Type BU105
 B105
 B105C
 B105KM
 BKT
 H105
 HC105
 VDI

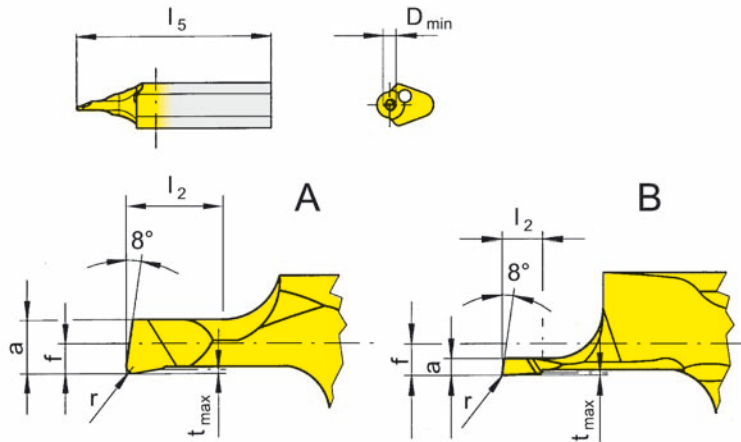

R = right hand version shown

L = left hand version

Part number	f	a	l ₂	l ₅	t _{max}	D _{min}	r	Form	Carbide grades					
									MG12	TN35	TI25	TF45	TH35	
R/L105.1802.0.02	.039	.007	.039	.906	.001	.008	.001	B	▲/▲					
R/L105.1802.0.03	.039	.010	.039	.906	.001	.012	.001	B	▲/▲					
R/L105.1802.0.05	.039	.016	.079	.906	.002	.020	.002	B	▲/▲					
R/L105.1803.0.07	.012	.024	.079	.906	.002	.028	.002	A	▲/▲					
▲ on stock Δ 4 weeks ● main recommendation ○ alternative recommendation □ uncoated grades ■ coated grades ■ brazed/Cermet										P	○			
										M	●			
										K	●			
										S	●			
										N	●			
										H				

Dimensions in inch

State R or L version

INSERT Type

105

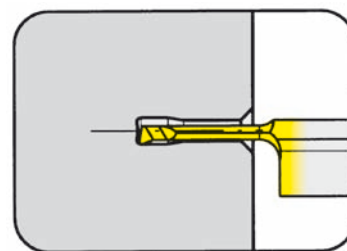

Bore Ø from .039''

for use with Toolholder

- Type BU105
 B105
 B105C
 B105KM
 BKT
 H105
 HC105
 VDI

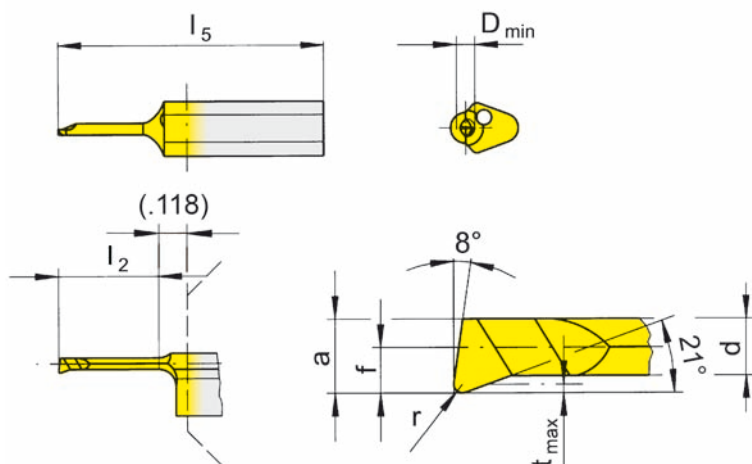

R = right hand version shown

L = left hand version

Part number	f	a	d	l ₂	l ₅	t _{max}	D _{min}	r	Carbide grades					
									MG12	TN35	TI25	TF45	TH35	
R/L105.1805.005.0.1				.157	.984	.004	.039	.002				▲▲		
R/L105.1805.005.1.1	.020	.035	.026	.236	.984	.004	.039	.002				▲▲		
R/L105.1805.005.2.1				.315								▲▲		
R/L105.1805.0.1				.157	.984	.004	.039	.004	▲/Δ	▲/▲	▲/Δ			
R/L105.1805.1.1	.020	.035	.026	.236	.984	.004	.039	.004		▲/▲	▲/▲			
R/L105.1805.2.1				.315						▲/▲	▲/▲			
R/L105.1813.005.0.15				.236	.984	.006	.059	.002				▲▲		
R/L105.1813.005.1.15	.051	.055	.043	.354	.984	.006	.059	.002				▲▲		
R/L105.1813.005.2.15				.472	1.181							▲▲		
R/L105.1813.01.0.15				.236	.984	.006	.059	.004				▲/▲		▲/▲
R/L105.1813.01.1.15	.051	.055	.043	.354	.984	.006	.059	.004				▲/▲		▲/▲
R/L105.1813.01.2.15				.472	1.181							▲/▲		▲/▲

- ▲ on stock Δ 4 weeks
- main recommendation
- alternative recommendation
- uncoated grades
- coated grades
- brazed/Cermet

Dimensions in inch

State R or L version

Carbide grades

INSERT Type

105

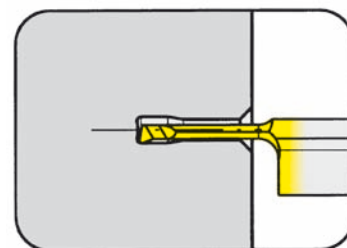

Bore Ø from .079''

for use with Toolholder

- Type BU105
 B105
 B105C
 B105KM
 BKT
 H105
 HC105
 VDI

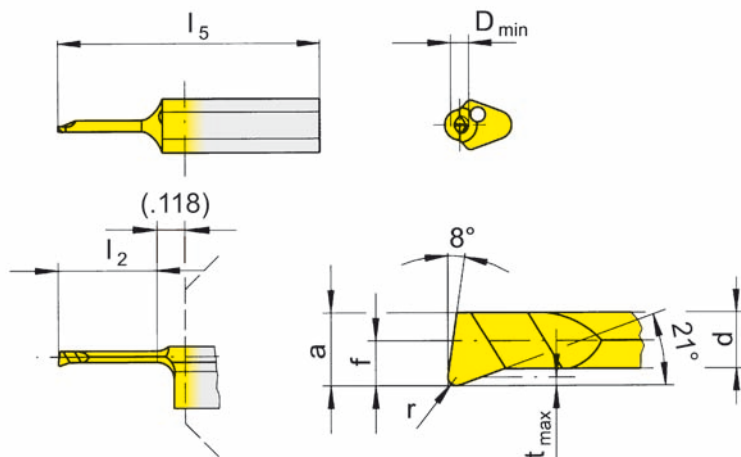

R = right hand version shown

L = left hand version

Part number	f	a	d	l ₂	l ₅	t _{max}	D _{min}	r	Carbide grades					
									MG12	TN35	TI25	TF45	TH35	
R/L105.1809.005.0.2				.236	.984							▲▲		
R/L105.1809.005.1.2	.039	.075	.063	.354	.984	.006	.079	.002				▲▲		
R/L105.1809.005.2.2				.472	1.181							▲▲		
R/L105.1809.01.0.2				.236	.984							▲▲		▲▲
R/L105.1809.01.1.2	.039	.075	.063	.354	.984	.006	.079	.004				▲▲		▲▲
R/L105.1809.01.2.2				.472	1.181							▲▲		▲▲
R/L105.1809.0.2				.236	.984				▲/Δ	▲/▲	▲/▲			▲/▲
R/L105.1809.1.2	.039	.075	.063	.354	.984	.006	.079	.006	▲/Δ	▲/▲	▲/▲			▲/▲
R/L105.1809.2.2				.472	1.181				▲/Δ	▲/▲	▲/▲			▲/▲
R/L105.1813.005.0.25				.236	.984									▲/▲
R/L105.1813.005.1.25				.354	.984									▲▲
R/L105.1813.005.2.25	.051	.091	.077	.472	1.181	.006	.098	.002				▲▲		▲▲
R/L105.1813.005.3.25				.630	1.378							▲/		

- ▲ on stock Δ 4 weeks
- main recommendation
- alternative recommendation
- uncoated grades
- coated grades
- brazed/Cermet

Dimensions in inch
 State R or L version

P	○	●	●	●	●
M	●	●	●	●	●
K	●	●	●	●	●
S	●	●	●	●	●
N	●	●	●	●	●
H					

Carbide grades

INSERT Type

105

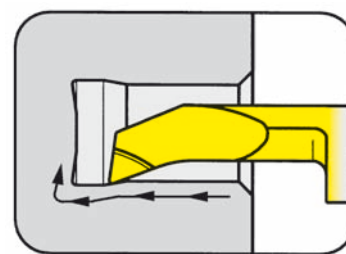

Bore Ø from .118''

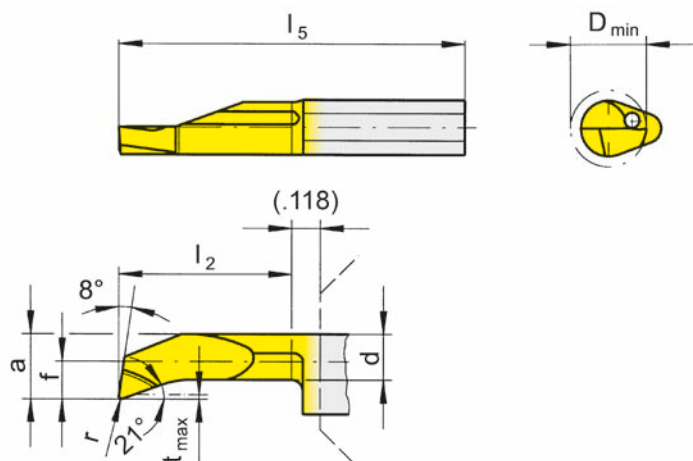

for use with Toolholder

- Type
- BU105
 - B105
 - B105C
 - B105KM
 - BKT
 - H105
 - HC105
 - VDI

R = right hand version shown

L = left hand version

Part number	f	a	d	l ₂	l ₅	t _{max}	D _{min}	r	Carbide grades					
									MG12	TN35	TI25	TF45	TH35	
R/L105.1813.005.1.3				.394	.984							▲▲		
R/L105.1813.005.2.3	.051	.102	.091	.591	1.181	.006	.118	.002				▲▲		
R/L105.1813.005.3.3				.787	1.378							▲▲		
R/L105.1813.01.1.3				.394	.984							▲▲		▲▲
R/L105.1813.01.2.3	.051	.102	.091	.591	1.181	.006	.118	.004				▲▲		▲▲
R/L105.1813.01.3.3				.787	1.378							▲▲		▲▲
R/L105.1813.1.3				.394	.984				▲/▲	▲/▲	▲/▲			▲/▲
R/L105.1813.2.3	.051	.102	.091	.591	1.181	.006	.118	.008	▲/▲	▲/▲	▲/▲			▲/▲
R/L105.1813.3.3				.787	1.378				▲/▲	▲/▲	▲/▲			▲/▲
R/L105.1819.005.1.4				.394	.984								▲▲	
R/L105.1819.005.2.4	.075	.146	.114	.591	1.181	.012	.157	.002					▲▲	
R/L105.1819.005.3.4				.787	1.378								▲▲	
R/L105.1819.1.4				.394	.984				▲/▲	▲/▲	▲/▲			▲/▲
R/L105.1819.2.4	.075	.146	.114	.591	1.181	.012	.157	.008	▲/▲	▲/▲	▲/▲			▲/▲
R/L105.1819.3.4				.787	1.378				▲/▲	▲/▲	▲/▲			▲/▲

- ▲ on stock Δ 4 weeks
- main recommendation
- alternative recommendation
- uncoated grades
- coated grades
- brazed/Cermet

Dimensions in inch

State R or L version

Carbide grades

INSERT Type

105

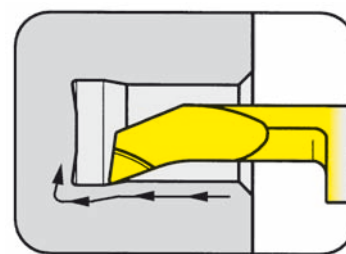

Bore Ø from .197''

for use with Toolholder

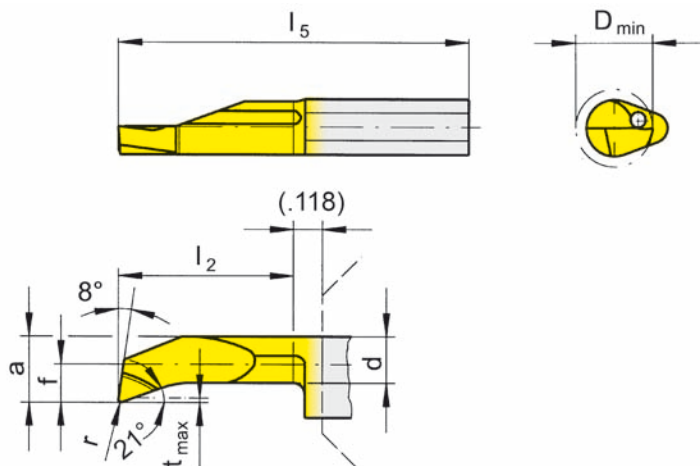

- Type BU105
B105
B105C
B105KM
BKT
H105
HC105
VDI

R = right hand version shown

L = left hand version

Part number	f	a	d	l ₂	l ₅	t _{max}	D _{min}	r	Carbide grades					
									MG12	TN35	TI25	TF45	TH35	
R/L105.1823.005.1.5				.394	.984							▲▲		
R/L105.1823.005.2.5				.591	1.181							▲▲		
R/L105.1823.005.3.5	.091	.185	.157	.787	1.378	.020	.197	.002				▲▲		
R/L105.1823.005.4.5				.984	1.575							▲▲		
R/L105.1823.005.5.5				1.181	1.772							▲▲		
R/L105.1823.1.5				.394	.984				▲/▲	▲/▲	▲/▲			▲/▲
R/L105.1823.2.5				.591	1.181				▲/▲	▲/▲	▲/▲			▲/▲
R/L105.1823.3.5	.091	.185	.157	.787	1.378	.020	.197	.008	▲/▲	▲/▲	▲/▲			▲/▲
R/L105.1823.4.5				.984	1.575				▲/▲	▲/▲	▲/▲			▲/▲
R/L105.1823.5.5				1.181	1.772				▲/▲	▲/▲	▲/▲			▲/▲

- ▲ on stock Δ 4 weeks
- main recommendation
- alternative recommendation
- uncoated grades
- coated grades
- brazed/Cermet

	P	M	K	S	N	H
MG12	○	●	●	●	●	●
TN35	●	●	●	●	●	●
TI25	●	●	●	●	●	●
TF45	●	●	●	●	●	●
TH35	●	●	●	●	●	●

Carbide grades

Dimensions in inch

State R or L version

INSERT Type

105

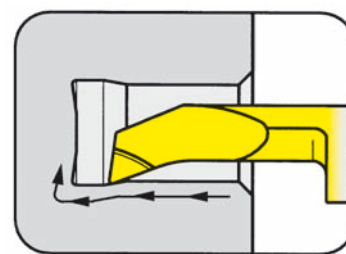

Bore Ø from .236''

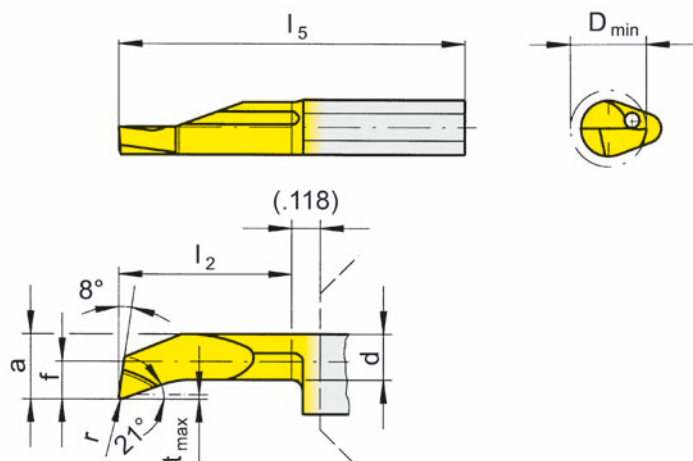

for use with Toolholder

- Type BU105
B105
B105C
B105KM
BKT
H105
HC105
VDI

R = right hand version shown

L = left hand version

Part number	f	a	d	l ₂	l ₅	t _{max}	D _{min}	r	Carbide grades				
									MG12	TN35	TI25	TF45	TH35
R/L105.1833.005.2.6	.130	.224	.185	.591	1.181	.020	.236	.002				▲▲	
R/L105.1833.005.3.6				.787	1.378				▲▲				
R/L105.1833.005.4.6				.984	1.575				▲▲				
R/L105.1833.005.5.6				1.181	1.772				▲▲				
R/L105.1833.2.6	.130	.224	.185	.591	1.181	.020	.236	.008	▲/▲	▲/▲	▲▲		▲/▲
R/L105.1833.3.6				.787	1.378				▲/▲	▲▲	▲/▲		
R/L105.1833.4.6				.984	1.575				▲/▲	▲▲	▲/▲		
R/L105.1833.5.6				1.181	1.772				▲/▲	▲▲	▲/▲		
R/L105.1840.005.3.7	.157	.252	.205	.787	1.378	.020	.268	.002				▲▲	
R/L105.1840.005.4.7				.984	1.575				▲▲				
R/L105.1840.005.5.7				1.181	1.772				▲▲				
R/L105.1840.3.7	.157	.252	.205	.787	1.378	.020	.268	.008	▲/▲	▲/▲	▲▲		▲/▲
R/L105.1840.4.7				.984	1.575				▲/▲	▲▲	▲/▲		
R/L105.1840.5.7				1.181	1.772				▲/▲	▲▲	▲/▲		

- ▲ on stock Δ 4 weeks
- main recommendation
- alternative recommendation
- uncoated grades
- coated grades
- brazed/Cermet

Dimensions in inch

State R or L version

Carbide grades

INSERT Type

105

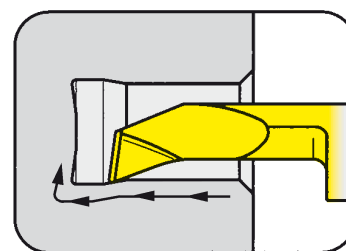

Bore Ø from .157''

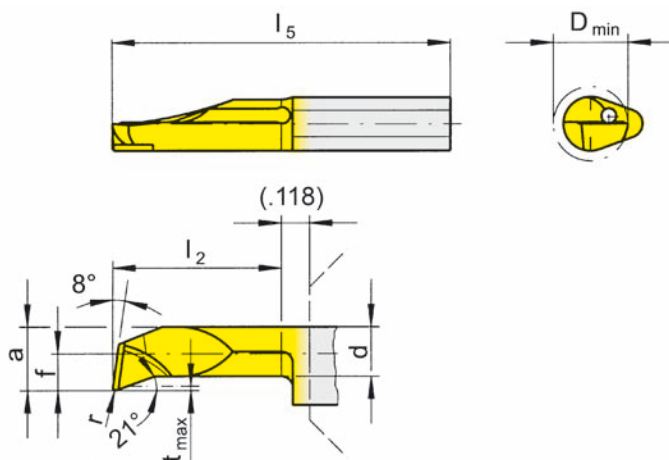

for use with Toolholder

- Type BU105
 B105
 B105C
 B105KM
 BKT
 H105
 HC105
 VDI

extended chip breaker
 (geometry HV)

R = right hand version shown

L = left hand version

Part number	f	a	d	l ₂	l ₅	t _{max}	D _{min}	r	Carbide grades					
									MG12	TN35	TI25	TF45	TH35	
R/L105.1819.1.HV4				.394	.984									▲▲
R/L105.1819.2.HV4	.075	.146	.114	.591	1.181	.012	.157	.008						▲▲
R/L105.1819.3.HV4				.787	1.378									▲▲
R/L105.1823.1.HV5				.394	.984									▲▲
R/L105.1823.2.HV5				.591	1.181									▲▲
R/L105.1823.3.HV5	.091	.185	.157	.787	1.378	.020	.197	.008						▲▲
R/L105.1823.4.HV5				.984	1.575									▲▲
R/L105.1823.5.HV5				1.181	1.772									▲▲
R/L105.1833.2.HV6				.591	1.181									▲▲
R/L105.1833.3.HV6				.787	1.378									▲▲
R/L105.1833.4.HV6	.130	.224	.185	.984	1.575	.020	.236	.008						▲▲
R/L105.1833.5.HV6				1.181	1.772									▲▲
R/L105.1840.3.HV7				.787	1.378									▲▲
R/L105.1840.4.HV7	.157	.252	.205	.984	1.575	.020	.268	.008						▲▲
R/L105.1840.5.HV7				1.181	1.772									▲▲

- ▲ on stock Δ 4 weeks
- main recommendation
- alternative recommendation
- uncoated grades
- coated grades
- brazed/Cermet

P				●
M				●
K				●
S				●
N				●
H				

Dimensions in inch

Carbide grades

State R or L version

INSERT Type

105

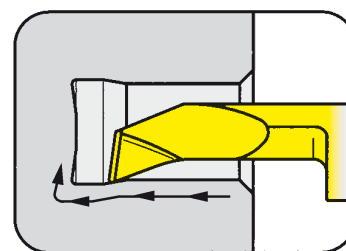

Bore Ø from .157''

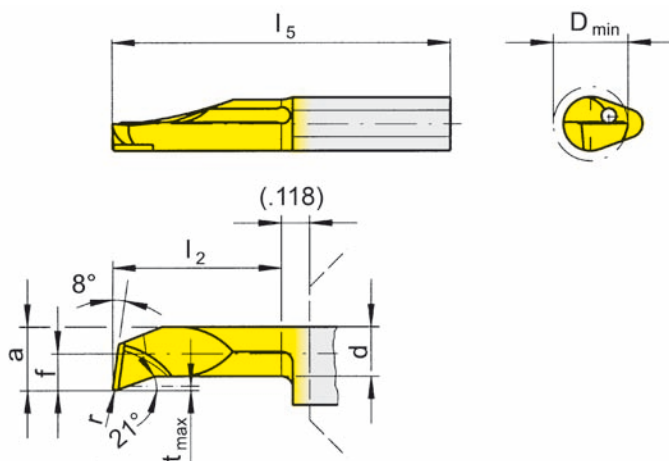

for use with Toolholder

- Type
- BU105
 - B105
 - B105C
 - B105KM
 - BKT
 - H105
 - HC105
 - VDI

extended chip breaker
(geometry HV)

R = right hand version shown

L = left hand version

Part number	f	a	d	l ₂	l ₅	t _{max}	D _{min}	r	Carbide grades					
									MG12	TN35	TI25	TF45	TH35	
R/L105.1819.04.1.HV4				.394	.984									▲▲
R/L105.1819.04.2.HV4	.075	.146	.114	.591	1.181	.012	.157	.016						▲▲
R/L105.1819.04.3.HV4				.787	1.378									▲▲
R/L105.1823.04.1.HV5				.394	.984									▲▲
R/L105.1823.04.2.HV5				.591	1.181									▲▲
R/L105.1823.04.3.HV5	.091	.185	.157	.787	1.378	.020	.197	.016						▲▲
R/L105.1823.04.4.HV5				.984	1.575									▲▲
R/L105.1823.04.5.HV5				1.181	1.772									▲▲
R/L105.1833.04.2.HV6				.591	1.181									▲▲
R/L105.1833.04.3.HV6				.787	1.378									▲▲
R/L105.1833.04.4.HV6	.130	.224	.185	.984	1.575	.020	.236	.016						▲▲
R/L105.1833.04.5.HV6				1.181	1.772									▲▲
R/L105.1840.04.2.HV7				.591	1.181									▲▲
R/L105.1840.04.3.HV7				.787	1.378									▲▲
R/L105.1840.04.4.HV7	.157	.252	.205	.984	1.575	.020	.268	.016						▲▲
R/L105.1840.04.5.HV7				1.181	1.772									▲▲

- ▲ on stock Δ 4 weeks
- main recommendation
- alternative recommendation
- uncoated grades
- coated grades
- brazed/Cermet

P					●
M					●
K					●
S					●
N					●
H					

Dimensions in inch

Carbide grades

State R or L version

INSERT Type

105

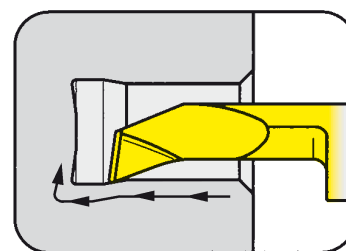

Bore Ø from .157"

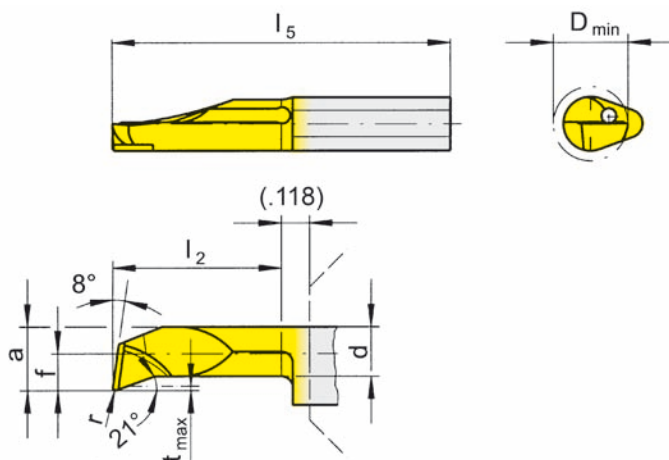

for use with Toolholder

- Type BU105
- B105
- B105C
- B105KM
- BKT
- H105
- HC105
- VDI

with chip breaker
(geometry H)

R = right hand version shown

L = left hand version

Part number	f	a	d	l ₂	l ₅	t _{max}	D _{min}	r	Carbide grades					
									MG12	TN35	TI25	TF45	TH35	
R/L105.1819.1.H4				.394	.984							▲▲	▲▲	
R/L105.1819.2.H4	.075	.146	.114	.591	1.181	.012	.157	.008				▲▲	▲▲	▲▲
R/L105.1819.3.H4				.787	1.378							▲▲	▲▲	
R/L105.1823.1.H5				.394	.984							▲▲	▲▲	▲▲
R/L105.1823.2.H5				.591	1.181							▲▲	▲▲	▲▲
R/L105.1823.3.H5	.091	.185	.157	.787	1.378	.020	.197	.008				▲▲	▲▲	▲▲
R/L105.1823.4.H5				.984	1.575							▲▲	▲▲	▲▲
R/L105.1823.5.H5				1.181	1.772							▲▲	▲▲	▲▲
R/L105.1833.2.H6				.591	1.181							▲▲	▲▲	▲▲
R/L105.1833.3.H6				.787	1.378							▲▲	▲▲	▲▲
R/L105.1833.4.H6	.130	.224	.185	.984	1.575	.020	.236	.008				▲▲	▲▲	▲▲
R/L105.1833.5.H6				1.181	1.772							▲▲	▲▲	▲▲
R/L105.1840.3.H7				.787	1.378							▲▲	▲▲	▲▲
R/L105.1840.4.H7	.157	.252	.205	.984	1.575	.020	.268	.008				▲▲	▲▲	▲▲
R/L105.1840.5.H7				1.181	1.772							▲▲	▲▲	▲▲

- ▲ on stock ▲ 4 weeks
- main recommendation
- alternative recommendation
- uncoated grades
- coated grades
- brazed/Cermet

P			●	●
M			●	●
K			●	●
S			●	●
N			●	●
H				

Carbide grades

Dimensions in inch

State R or L version

INSERT Type

105

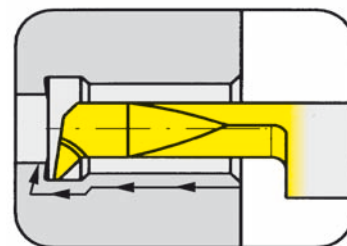

Bore Ø from .157''

for use with Toolholder

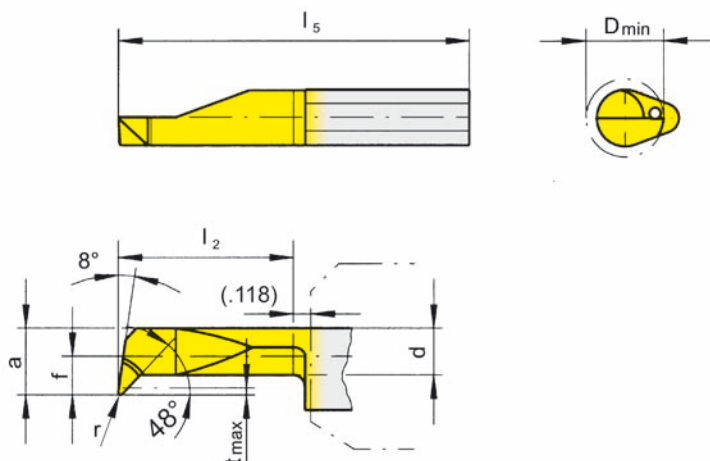

- Type BU105
B105
B105C
B105KM
BKT
H105
HC105
VDI

R = right hand version shown

L = left hand version

Part number	f	a	d	l ₂	l ₅	t _{max}	D _{min}	r	Carbide grades				
									MG12	TN35	TI25	TF45	TH35
R/L105.4719.1.4	.075	.146	.114	.394	.984	.024	.157	.006					▲/▲
R/L105.4719.3.4										▲/▲	▲/▲		▲/▲
R/L105.4723.2.5	.091	.185	.146	.591	1.181	.031	.197	.006					▲/▲
R/L105.4723.4.5										▲/▲	▲/▲		▲/▲
R/L105.4733.3.6	.130	.224	.146	.787	1.378	.071	.236	.006					▲/▲
R/L105.4733.5.6										▲/▲	Δ/		▲/▲
									P	•	•		•
									M	•	•		•
									K	•	•		•
									S	•	•		•
									N	•	•		•
									H				

- ▲ on stock Δ 4 weeks
- main recommendation
- o alternative recommendation
- uncoated grades
- coated grades
- brazed/Cermet

Dimensions in inch

State R or L version

Carbide grades

INSERT Type

105

reinforced version

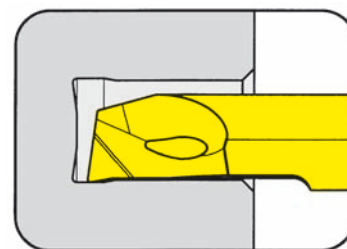

Bore Ø from .157''

for use with Toolholder

- Type
- BU105
 - B105
 - B105C
 - B105KM
 - BKT
 - H105
 - HC105
 - VDI

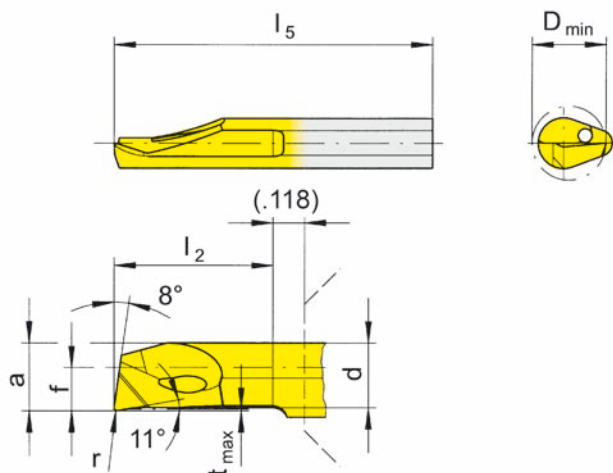

R = right hand version shown

L = left hand version

Part number	f	a	d	l ₂	l ₅	t _{max}	D _{min}	r	Carbide grades				
									MG12	TN35	TI25	TF45	TH35
R/L105.1019.005.1.4				.394	.984								▲▲
R/L105.1019.005.2.4				.591	1.181								▲▲
R/L105.1019.005.3.4	.059	.146	.134	.787	1.378	.006	.157	.002					▲▲
R/L105.1019.005.4.4				.984	1.575								▲▲
R/L105.1019.1.4				.394	.984								▲▲
R/L105.1019.2.4				.591	1.181								▲▲
R/L105.1019.3.4	.059	.146	.134	.787	1.378	.006	.157	.008					▲▲
R/L105.1019.4.4				.984	1.575								▲▲

- ▲ on stock Δ 4 weeks
- main recommendation
- alternative recommendation
- uncoated grades
- coated grades
- brazed/Cermet

	P	M	K	S	N	H
MG12						
TN35						
TI25						
TF45						
TH35	●	●	●	●	●	●

Carbide grades

Dimensions in inch

State R or L version

INSERT Type

105

reinforced version

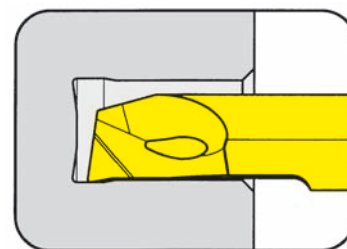

Bore Ø from .197''

for use with Toolholder

- Type
- BU105
 - B105
 - B105C
 - B105KM
 - BKT
 - H105
 - HC105
 - VDI

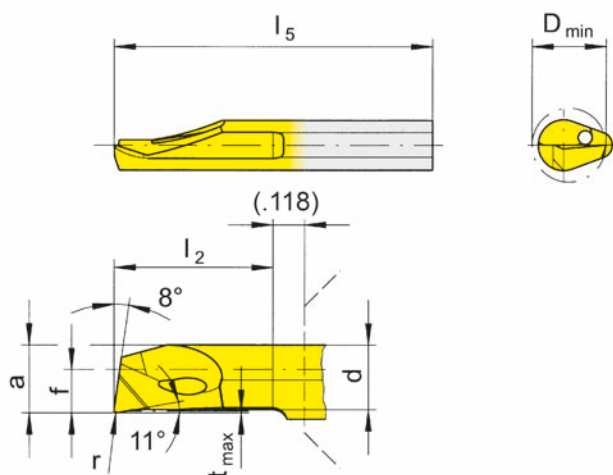

R = right hand version shown

L = left hand version

Part number	f	a	d	l ₂	l ₅	t _{max}	D _{min}	r	Carbide grades				
									MG12	TN35	TI25	TF45	TH35
R/L105.1023.005.1.5				.394	.984								▲▲
R/L105.1023.005.2.5				.591	1.181								▲▲
R/L105.1023.005.3.5	.110	.185	.173	.787	1.378	.006	.197	.002					▲▲
R/L105.1023.005.4.5				.984	1.575								▲▲
R/L105.1023.005.5.5				1.181	1.772								▲▲
R/L105.1023.005.6.5				1.378	1.969								▲▲
R/L105.1023.1.5				.394	.984								▲▲
R/L105.1023.2.5				.591	1.181								▲▲
R/L105.1023.3.5	.110	.185	.173	.787	1.378	.006	.197	.008					▲▲
R/L105.1023.4.5				.984	1.575								▲▲
R/L105.1023.5.5				1.181	1.772								▲▲
R/L105.1023.6.5				1.378	1.969								▲▲
▲ on stock Δ 4 weeks ● main recommendation ○ alternative recommendation □ uncoated grades ■ coated grades ■ brazed/Cermet									P				●
									M				●
									K				●
									S				●
									N				●
									H				

Dimensions in inch

Carbide grades

State R or L version

INSERT Type

105

reinforced version

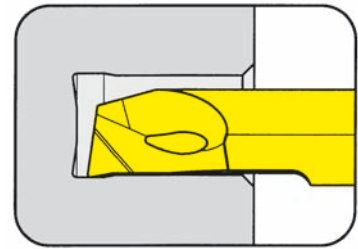

Bore Ø from .236''

for use with Toolholder

- Type BU105
 B105
 B105C
 B105KM
 BKT
 H105
 HC105
 VDI

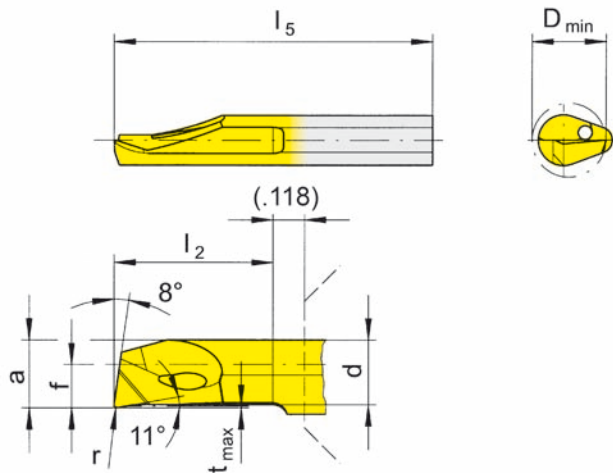

R = right hand version shown

L = left hand version

Part number	f	a	d	l ₂	l ₅	t _{max}	D _{min}	r	Carbide grades				
									MG12	TN35	TI25	TF45	TH35
R/L105.1033.005.1.6				.394	.984								▲▲
R/L105.1033.005.2.6				.591	1.181								▲▲
R/L105.1033.005.3.6	.130	.224	.213	.787	1.378	.006	.236	.002					▲▲
R/L105.1033.005.4.6				.984	1.575								▲▲
R/L105.1033.005.5.6				1.181	1.772								▲▲
R/L105.1033.005.6.6				1.378	1.969								▲▲
R/L105.1033.1.6				.394	.984								▲▲
R/L105.1033.2.6				.591	1.181								▲▲
R/L105.1033.3.6	.130	.224	.213	.787	1.378	.006	.236	.008					▲▲
R/L105.1033.4.6				.984	1.575								▲▲
R/L105.1033.5.6				1.181	1.772								▲▲
R/L105.1033.6.6				1.378	1.969								▲▲
									P				•
									M				•
									K				•
									S				•
									N				•
									H				

- ▲ on stock Δ 4 weeks
- main recommendation
- o alternative recommendation
- uncoated grades
- coated grades
- brazed/Cermet

Dimensions in inch

Carbide grades

State R or L version

INSERT Type

105

reinforced version

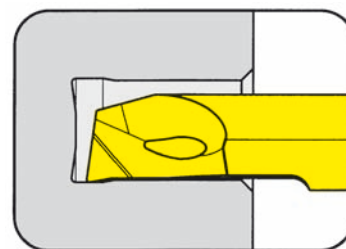

Bore Ø from .268''

for use with Toolholder

- Type
- BU105
 - B105
 - B105C
 - B105KM
 - BKT
 - H105
 - HC105
 - VDI

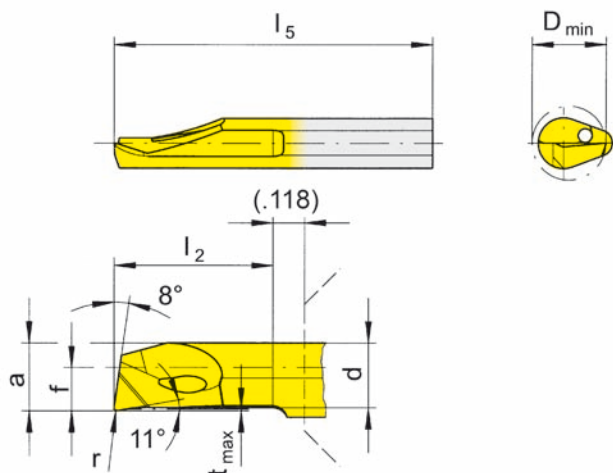

R = right hand version shown

L = left hand version

Part number	f	a	d	l ₂	l ₅	t _{max}	D _{min}	r	Carbide grades				
									MG12	TN35	TI25	TF45	TH35
R/L105.1040.1.7				.394	.984								▲▲
R/L105.1040.2.7				.591	1.181								▲▲
R/L105.1040.3.7	.157	.252	.240	.787	1.378	.006	.268	.008					▲▲
R/L105.1040.4.7				.984	1.575								▲▲
R/L105.1040.5.7				1.181	1.772								▲▲
R/L105.1040.6.7				1.378	1.969								▲▲
▲ on stock Δ 4 weeks ● main recommendation ○ alternative recommendation □ uncoated grades ■ coated grades ■ brazed/Cermet									P				●
									M				●
									K				●
									S				●
									N				●
									H				

Dimensions in inch

Carbide grades

State R or L version

INSERT Type

105

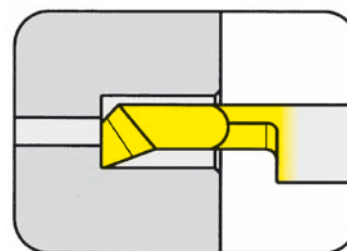

Bore Ø from .118''

for use with Toolholder

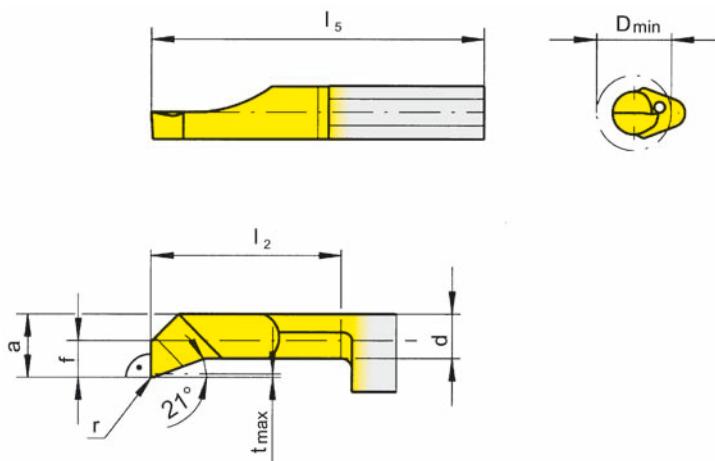

- Type
- BU105
 - B105
 - B105C
 - B105KM
 - BKT
 - H105
 - HC105
 - VDI

R = right hand version shown

L = left hand version

Part number	f	a	d	l ₂	l ₅	t _{max}	D _{min}	r	Carbide grades					
									MG12	TN35	TI25	TF45	TH35	
R/L105.9013.01.1.3	.051	.102	.091	.394	.984	.006	.118	.004					▲/▲	
R/L105.9013.01.2.3				.591	1.181									
R/L105.9013.1.3				.394	.984									
R/L105.9013.2.3				.591	1.181									
R/L105.9019.01.1.4	.075	.146	.114	.394	.984	.012	.157	.004					▲/▲	
R/L105.9019.01.2.4				.591	1.181									
R/L105.9019.01.3.4				.787	1.378									
R/L105.9019.1.4				.394	.984									
R/L105.9019.2.4				.591	1.181									

- ▲ on stock Δ 4 weeks
- main recommendation
- alternative recommendation
- uncoated grades
- coated grades
- brazed/Cermet

Dimensions in inch

State R or L version

Carbide grades

INSERT Type

105

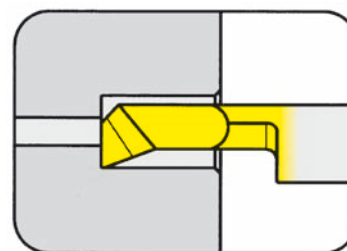

Bore Ø from .197''

for use with Toolholder

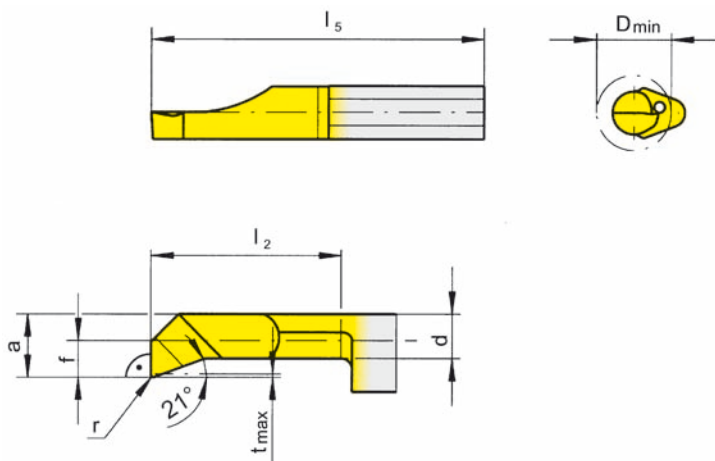

- Type BU105
B105
B105C
B105KM
BKT
H105
HC105
VDI

R = right hand version shown

L = left hand version

Part number	f	a	d	l ₂	l ₅	t _{max}	D _{min}	r	Carbide grades					
									MG12	TN35	TI25	TF45	TH35	
R/L105.9023.01.1.5				.394	.984			.004						▲/Δ
R/L105.9023.01.2.5				.591	1.181			.004						▲/Δ
R/L105.9023.01.3.5				.787	1.378			.004						▲/Δ
R/L105.9023.01.4.5	.091	.185	.157	.984	1.575	.020	.197	.004						▲/
R/L105.9023.1.5				.394	.984			.008		▲/▲				▲/
R/L105.9023.2.5				.591	1.181			.008		▲/▲				
R/L105.9023.3.5				.787	1.378			.008		▲/▲				
R/L105.9033.1.6				.394	.984									Δ/
R/L105.9033.2.6				.591	1.181									Δ/Δ
R/L105.9033.3.6	.130	.224	.185	.787	1.378	.020	.236	.008						Δ/Δ
R/L105.9033.4.6				.984	1.575									Δ/Δ
R/L105.9033.5.6				1.181	1.772									Δ/Δ
▲ on stock Δ 4 weeks ● main recommendation ○ alternative recommendation □ uncoated grades ■ coated grades ■ brazed/Cermet									P	●	■	■	●	
									M	●	■	■	●	
									K	●	■	■	●	
									S	●	■	■	●	
									N	●	■	■	●	
									H					

Dimensions in inch

Carbide grades

State R or L version

INSERT Type

105

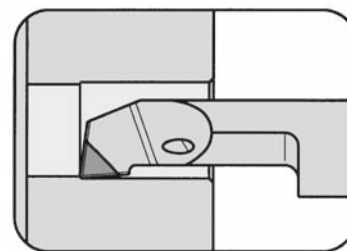

Bore Ø from .118"

for use with Toolholder

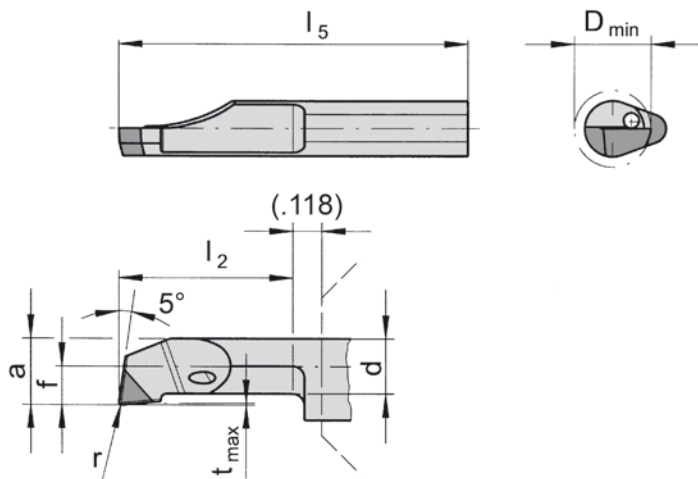

- Type BU105
 B105
 B105C
 B105KM
 BKT
 H105
 HC105
 VDI

CBN tipped

R = right hand version shown

Part number	f	a	d	l ₂	l ₅	t _{max}	D _{min}	r	CB10
R105.0513.0.3.B	.051	.106	.098	.276	.984	.004	.118	.006	▲
R105.0519.1.4.B	.059	.146	.134	.394	.984	.004	.157	.008	▲
R105.0523.2.5.B	.091	.185	.173	.591	1.181	.004	.197	.008	▲
R105.0533.2.6.B	.130	.224	.209	.591	1.181	.006	.236	.008	▲
R105.0533.3.6.B	.130	.224	.209	.787	1.378	.006	.236	.008	△
R105.0540.2.7.B	.157	.252	.236	.591	1.181	.006	.268	.008	▲

- ▲ on stock △ 4 weeks
- main recommendation
- alternative recommendation
- uncoated grades
- coated grades
- brazed/Cermet

P	■
M	■
K	■
S	■
N	■
H	●

Carbide grades

Dimensions in inch

INSERT Type

105

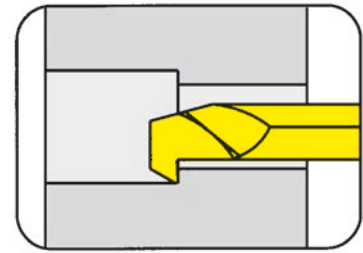

Bore Ø from .118"

for use with Toolholder

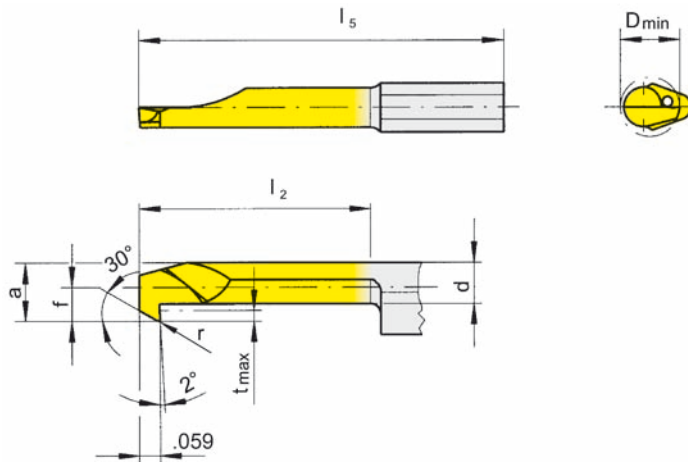

- Type
- BU105
 - B105
 - B105C
 - B105KM
 - BKT
 - H105
 - HC105
 - VDI

R = right hand version shown

L = left hand version

Part number	f	a	d	l ₂	l ₅	t _{max}	D _{min}	r	Carbide grades				
									MG12	TN35	TI25	TF45	TH35
R/L105.3013.2.3 R/L105.3013.3.3	.051	.102	.075	.591 .787	1.181 1.378	.020	.118	.004			▲/▲ ▲/Δ		
R/L105.3019.2.4 R/L105.3019.4.4	.075	.146	.106	.591 .984	1.181 1.575	.031	.157	.006			▲/▲ ▲/Δ		
R/L105.3023.3.5 R/L105.3023.5.5	.091	.185	.138	.787 1.181	1.378 1.772	.039	.197	.008			▲/▲ ▲/Δ		
R/L105.3033.3.6 R/L105.3033.5.6	.130	.224	.146	.787 1.181	1.378 1.772	.071	.236	.008			▲/▲ ▲/Δ		
R/L105.3040.3.7 R/L105.3040.5.7	.157	.252	.146	.787 1.181	1.378 1.772	.098	.268	.008			▲/▲ ▲/▲		

- ▲ on stock Δ 4 weeks
- main recommendation
- alternative recommendation

- uncoated grades
- coated grades
- brazed/Cermet

Dimensions in inch

State R or L version

	MG12	TN35	TI25	TF45	TH35
P			●		
M			●		
K			●		
S			●		
N			●		
H					

Carbide grades

INSERT Type

105

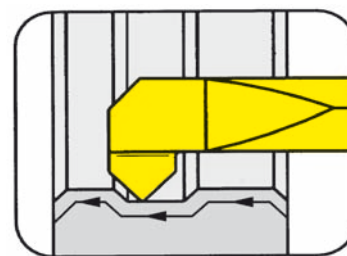

Bore Ø from .197"

for use with Toolholder

- Type
- BU105
 - B105
 - B105C
 - B105KM
 - BKT
 - H105
 - HC105
 - VDI

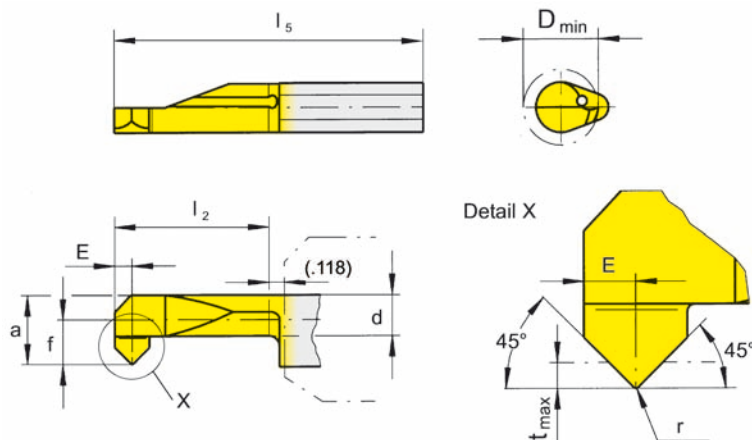

R = right hand version shown

L = left hand version

Part number	E	f	a	d	l ₂	l ₅	t _{max}	D _{min}	r	Carbide grades				
										MG12	TN35	TI25	TF45	TH35
R/L105.4545.2.5	.039	.091	.185	.138	.591	1.181	.028	.197	.008		▲/▲			
R/L105.4545.3.7	.039	.157	.252	.185	.787	1.378	.028	.276	.008		▲/▲			
										P	•			
										M	•			
										K	•			
										S	•			
										N	•			
										H				

- ▲ on stock Δ 4 weeks
- main recommendation
- o alternative recommendation
- uncoated grades
- coated grades
- brazed/Cermet

Dimensions in inch

State R or L version

Carbide grades

INSERT Type

105

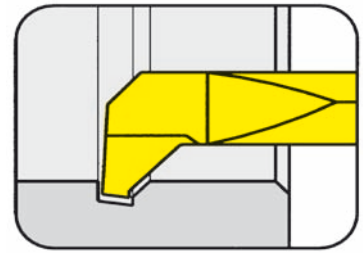

Bore Ø from .197"

for use with Toolholder

- Type BU105
 B105
 B105C
 B105KM
 BKT
 H105
 HC105
 VDI

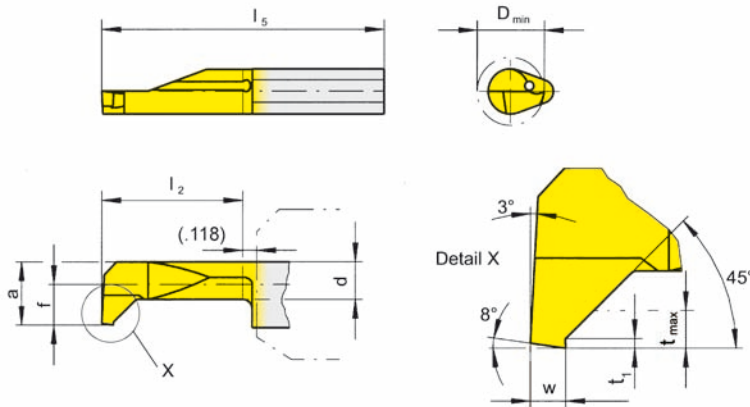

R = right hand version shown

L = left hand version

Part number	w	f	a	d	l ₂	l ₅	t ₁	t _{max}	D _{min}	Carbide grades					
										MG12	TN35	Ti25	TF45	TH35	
R/L105.0810.2.5					.591	1.181					▲/▲	▲/▲	●	●	
R/L105.0810.3.5	.039	.091	.185	.138	.787	1.378	.008	.028	.197		▲/▲	▲/▲	▲/▲	●	
R/L105.0810.4.5					.984	1.575					▲/▲	▲/▲	▲/▲	●	
											P	○	●	●	
											M	●	●	●	
											K	●	●	●	
											S	●	●	●	
											N	●	●	●	
											H				

- ▲ on stock Δ 4 weeks
- main recommendation
- alternative recommendation
- uncoated grades
- coated grades
- brazed/Cermet

Dimensions in inch

State R or L version

Carbide grades

GROOVING (internal) $\geq \text{Ø} .079''$



INSERT Type

105

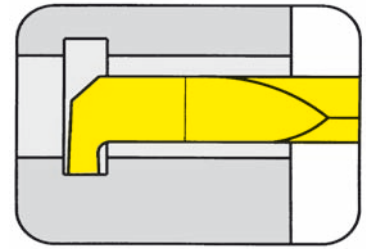

Bore Ø from	.079"
Depth of groove up to	.016"

for use with Toolholder

- Type BU105
 B105
 B105C
 B105KM
 BKT
 H105
 HC105
 VDI

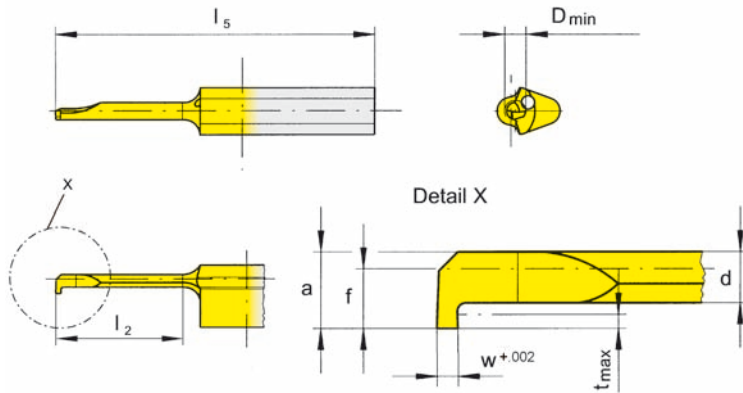

R = right hand version shown

L = left hand version

Part number	w	f	a	d	l ₂	l ₅	t _{max}	D _{min}	Carbide grades				
									MG12	TN35	TI25	TF45	TH35
R/L105.0050.0.2					.236	.984					▲▲		
R/L105.0050.1.2	.020	.055	.071	.047	.354	.984	.016	.079			▲▲		
R/L105.0050.2.2					.472	1.181					▲/▲		
											●		
											●		
											●		
											●		
											●		
											●		

- ▲ on stock Δ 4 weeks
- main recommendation
- alternative recommendation
- uncoated grades
- coated grades
- brazed/Cermet

Dimensions in inch

State R or L version

Carbide grades

GROOVING (internal) $\geq \text{Ø} .118''$



A

INSERT Type

105

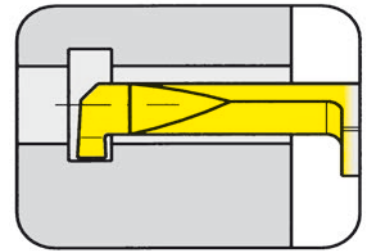

Bore Ø from $.118''$
Depth of groove up to $.024''$

for use with Toolholder

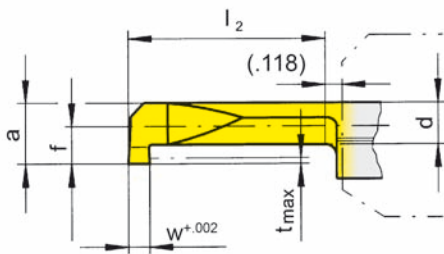
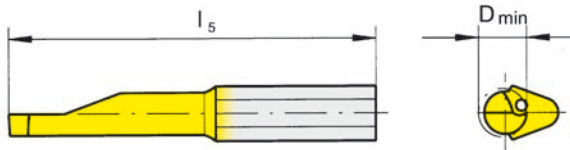

- Type BU105
B105
B105C
B105KM
BKT
H105
HC105
VDI

R = right hand version shown

L = left hand version

Part number	w	f	a	d	l ₂	l ₅	t _{max}	D _{min}	Carbide grades					
									MG12	TN35	TI25	TF45	TH35	
R/L105.0070.1.3					.315	.984					▲▲			
R/L105.0070.2.3	.028	.055	.106	.075	.472	1.181	.024	.118			▲▲			
R/L105.0070.3.3					.630	1.378					▲▲			
											●			
											●			
											○			
												■		
												■		
												■		
												■		
												■		

- ▲ on stock Δ 4 weeks
- main recommendation
- alternative recommendation
- uncoated grades
- coated grades
- brazed/Cermet

Dimensions in inch

State R or L version

Carbide grades

GROOVING (internal) $\geq \text{Ø} .157''$



INSERT Type

105

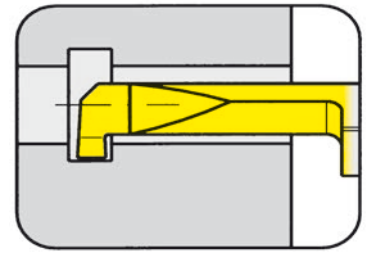

Bore Ø from .157''
 Depth of groove up to .031''

for use with Toolholder

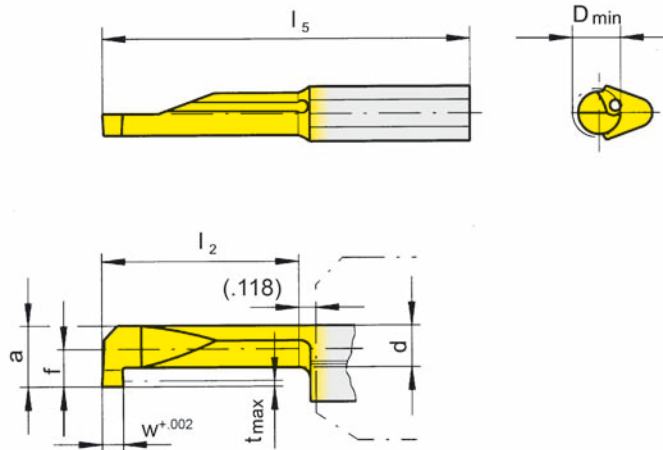

- Type BU105
 B105
 B105C
 B105KM
 BKT
 H105
 HC105
 VDI

R = right hand version shown

L = left hand version

Part number	w	f	a	d	l ₂	l ₅	t _{max}	D _{min}	Carbide grades				
									MG12	TN35	TI25	TF45	TH35
R/L105.0100.1.4					.394	.984		.157	▲/▲	▲/▲			
R/L105.0100.2.4	.039	.075	.146	.106	.591	1.181	.031	.157	▲/▲	▲/▲			
R/L105.0100.3.4					.787	1.378		.157	▲/▲	▲/▲			
									P	o	•		
									M	•	•		
									K	•	•		
									S	•	•		
									N	•	•		
									H				

- ▲ on stock Δ 4 weeks
- main recommendation
- o alternative recommendation
- uncoated grades
- coated grades
- brazed/Cermet

Dimensions in inch

State R or L version

Carbide grades

GROOVING (internal) $\geq \text{Ø} .157''$



A

INSERT Type

U105

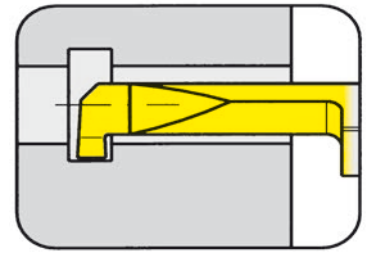

Bore Ø from $.157''$
Depth of groove up to $.031''$

for use with Toolholder

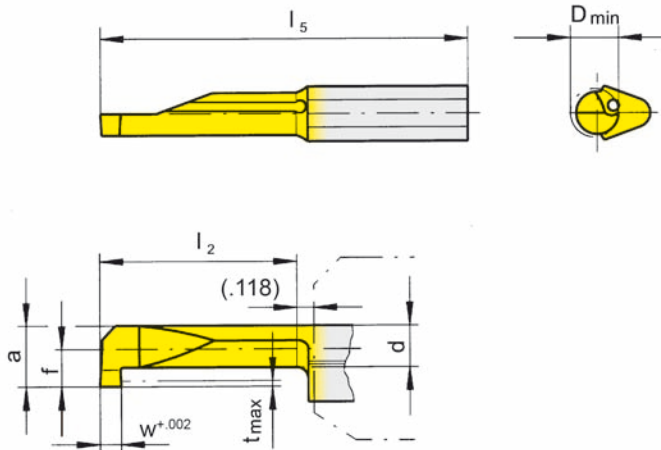

- Type BU105
B105
B105C
B105KM
BKT
H105
HC105
VDI

R = right hand version shown

L = left hand version

Part number	w	f	a	d	l ₂	l ₅	t _{max}	D _{min}	Carbide grades					
									MG12	TN35	TI25	TF45	TH35	
R/LU105.0031.1.4					.394	.984				▲/▲				▲/
R/LU105.0031.2.4	.031	.075	.146	.106	.591	1.181	.031	.157	▲/	▲/▲				▲/
R/LU105.0031.3.4					.787	1.378				▲/▲				▲/
									P	o	•			•
									M	•	•			•
									K	•	•			•
									S	•	•			•
									N	•	•			•
									H					

- ▲ on stock Δ 4 weeks
- main recommendation
- o alternative recommendation
- uncoated grades
- coated grades
- brazed/Cermet

Dimensions in inch

State R or L version

Carbide grades

GROOVING (internal) $\geq \text{Ø} .197''$



INSERT Type

105

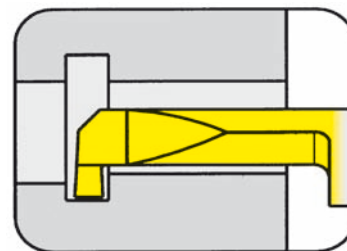

Bore Ø from $.197''$
Depth of groove up to $.039''$

for use with Toolholder

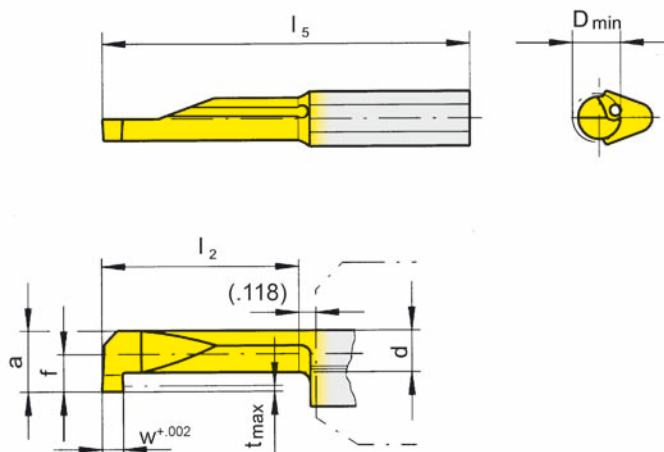

- Type BU105
B105
B105C
B105KM
BKT
H105
HC105
VDI

R = right hand version shown

L = left hand version

Part number	w	f	a	d	l ₂	l ₅	t _{max}	D _{min}	Carbide grades				
									MG12	TN35	TI25	TF45	TH35
R/L105.0100.1.5	.039								▲/▲	▲/▲			▲/▲
R/L105.0150.1.5	.059	.091	.185	.138	.394	.984	.039	.197	▲/▲	▲/▲			▲/▲
R/L105.0200.1.5	.079								▲/▲	▲/▲			▲/▲
R/L105.0100.2.5	.039								▲/▲	▲/▲			▲/▲
R/L105.0150.2.5	.059	.091	.185	.138	.591	1.181	.039	.197	▲/▲	▲/▲			▲/▲
R/L105.0200.2.5	.079								▲/▲	▲/▲			▲/▲
R/L105.0100.3.5	.039								▲/▲	▲/▲			▲/▲
R/L105.0150.3.5	.059	.091	.185	.138	.787	1.378	.039	.197	▲/▲	▲/▲			▲/▲
R/L105.0200.3.5	.079								▲/	▲/▲			▲/▲
R/L105.0100.4.5	.039									▲/▲			▲/▲
R/L105.0150.4.5	.059	.091	.185	.138	.984	1.575	.039	.197		▲/▲			▲/▲
R/L105.0200.4.5	.079									▲/▲			▲/▲
R/L105.0100.5.5	.039									▲/▲			▲/▲
R/L105.0150.5.5	.059	.091	.185	.138	1.181	1.772	.039	.197		▲/▲			▲/▲
R/L105.0200.5.5	.079									▲/▲			▲/▲

- ▲ on stock Δ 4 weeks
- main recommendation
- alternative recommendation
- uncoated grades
- coated grades
- brazed/Cermet

P	○	●	●	●
M	●	●	●	●
K	●	●	●	●
S	●	●	●	●
N	●	●	●	●
H				

Carbide grades

Dimensions in inch

State R or L version

GROOVING (internal) $\geq \text{Ø} .197''$



A

INSERT Type

U105

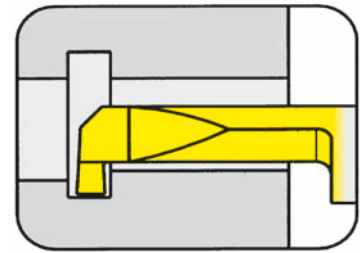

Bore Ø from $.197''$
Depth of groove up to $.039''$

for use with Toolholder

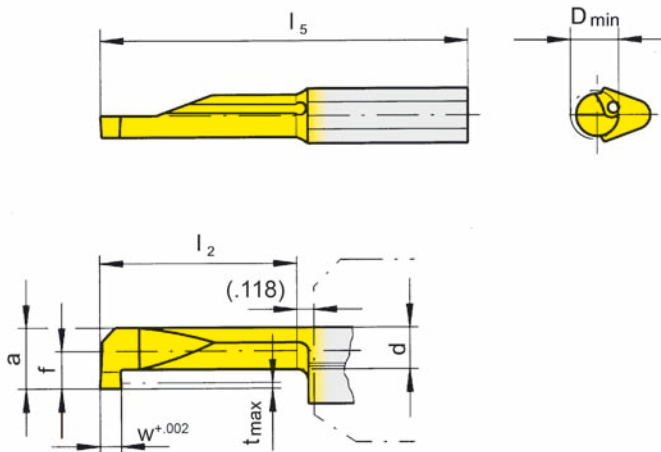

Type BU105
B105
B105C
B105KM
BKT
H105
HC105
VDI

R = right hand version shown

L = left hand version

Part number	w	f	a	d	l ₂	l ₅	t _{max}	D _{min}	Carbide grades					
									MG12	TN35	TI25	TF45	TH35	
R/LU105.0031.1.5	.031									▲/▲				▲/
R/LU105.0046.1.5	.046									▲/▲	Δ/			▲/
R/LU105.0062.1.5	.062	.091	.185	.138	.394	.984	.039	.197		▲/▲				▲/
R/LU105.0078.1.5	.078									▲/▲				▲/
R/LU105.0031.2.5	.031									▲/▲				▲/
R/LU105.0046.2.5	.046									▲/▲				▲/
R/LU105.0062.2.5	.062	.091	.185	.138	.591	1.181	.039	.197		▲/▲				▲/
R/LU105.0078.2.5	.078									▲/▲				▲/
R/LU105.0031.3.5	.031									▲/▲				▲/
R/LU105.0046.3.5	.046									▲/▲				▲/
R/LU105.0062.3.5	.062	.091	.185	.138	.787	1.378	.039	.197		▲/▲				▲/
R/LU105.0078.3.5	.078									▲/▲				▲/
R/LU105.0031.4.5	.031									▲/▲				▲/
R/LU105.0046.4.5	.046									▲/▲				▲/
R/LU105.0062.4.5	.062	.091	.185	.138	.984	1.575	.039	.197		▲/▲				▲/
R/LU105.0078.4.5	.078									▲/▲				▲/
R/LU105.0031.5.5	.031									▲/▲				▲/
R/LU105.0046.5.5	.046									▲/▲				▲/
R/LU105.0062.5.5	.062	.091	.185	.138	1.181	1.772	.039	.197		▲/▲				▲/
R/LU105.0078.5.5	.078									▲/▲				▲/

- ▲ on stock Δ 4 weeks
- main recommendation
- alternative recommendation
- uncoated grades
- coated grades
- brazed/Cermet

State R or L version

P	●	●	●	●
M	●	●	●	●
K	●	●	●	●
S	●	●	●	●
N	●	●	●	●
H				

Dimensions in inch

Carbide grades

GROOVING (internal) $\geq \text{Ø} .236''$



INSERT Type

105

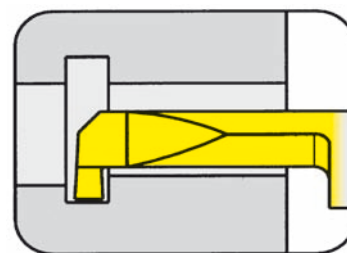

Bore Ø from $.236''$
Depth of groove up to $.071''$

for use with Toolholder

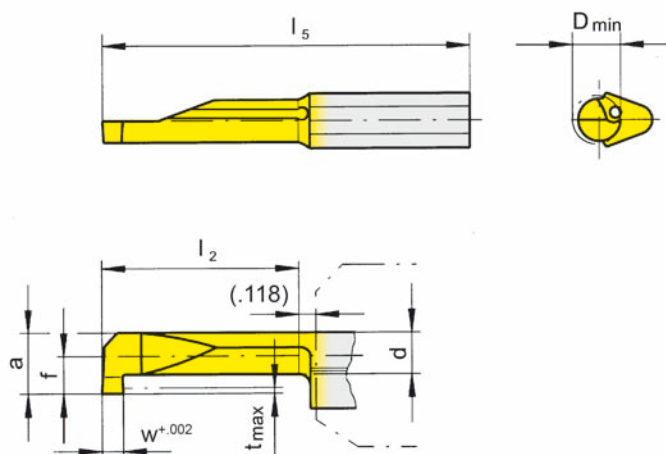

- Type BU105
B105
B105C
B105KM
BKT
H105
HC105
VDI

R = right hand version shown

L = left hand version

Part number	w	f	a	d	l ₂	l ₅	t _{max}	D _{min}	Carbide grades				
									MG12	TN35	TI25	TF45	TH35
R/L105.0100.1.6	.039								▲/▲	▲/▲			▲/▲
R/L105.0150.1.6	.059	.130	.224	.146	.394	.984	.071	.236	▲/▲	▲/▲			▲/▲
R/L105.0200.1.6	.079								▲/▲	▲/▲			▲/▲
R/L105.0100.2.6	.039								▲/▲	▲/▲			▲/▲
R/L105.0150.2.6	.059	.130	.224	.146	.591	1.181	.071	.236	▲/▲	▲/▲			▲/▲
R/L105.0200.2.6	.079								▲/▲	▲/▲			▲/▲
R/L105.0100.3.6	.039								▲/▲	▲/▲			▲/▲
R/L105.0150.3.6	.059	.130	.224	.146	.787	1.378	.071	.236	▲/▲	▲/▲			▲/▲
R/L105.0200.3.6	.079								▲/▲	▲/▲			▲/▲
R/L105.0100.4.6	.039									▲/▲			▲/▲
R/L105.0150.4.6	.059	.130	.224	.146	.984	1.575	.071	.236		▲/▲			▲/▲
R/L105.0200.4.6	.079									▲/▲			▲/▲
R/L105.0100.5.6	.039										▲/▲		▲/▲
R/L105.0150.5.6	.059	.130	.224	.146	1.181	1.772	.071	.236		▲/▲			▲/▲
R/L105.0200.5.6	.079									▲/▲			/▲

- ▲ on stock Δ 4 weeks
- main recommendation
- alternative recommendation
- uncoated grades
- coated grades
- brazed/Cermet

P	○	●	●	●
M	●	●	●	●
K	●	●	●	●
S	●	●	●	●
N	●	●	●	●
H				

Carbide grades

Dimensions in inch

State R or L version

GROOVING (internal) $\geq \text{Ø} .236''$



INSERT Type

U105

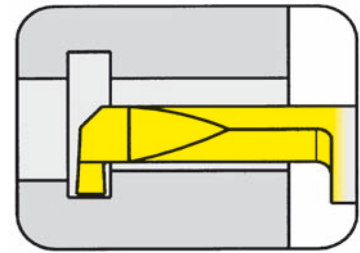

Bore Ø from $.236''$
 Depth of groove up to $.071''$

for use with Toolholder

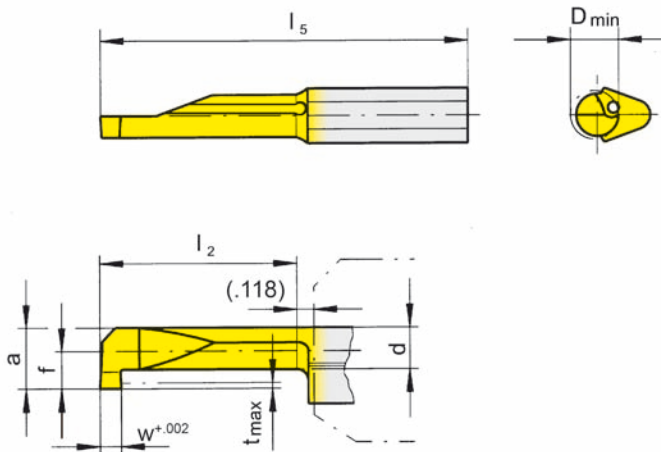

- Type BU105
 B105
 B105C
 B105KM
 BKT
 H105
 HC105
 VDI

R = right hand version shown

L = left hand version

Part number	w	f	a	d	l ₂	l ₅	t _{max}	D _{min}	Carbide grades				
									MG12	TN35	TI25	TF45	TH35
R/LU105.0031.1.6	.031								▲/	▲/▲			▲/
R/LU105.0046.1.6	.046							.236		▲/▲			▲/
R/LU105.0062.1.6	.062	.130	.224	.146	.394	.984	.071	.236		▲/▲			▲/
R/LU105.0078.1.6	.078								▲/	▲/▲			▲/
R/LU105.0031.2.6	.031									▲/▲			▲/
R/LU105.0046.2.6	.046									▲/▲			▲/
R/LU105.0062.2.6	.062	.130	.224	.146	.591	1.181	.071	.236		▲/▲			▲/
R/LU105.0078.2.6	.078								▲/	▲/▲			▲/
R/LU105.0031.3.6	.031									▲/▲			▲/
R/LU105.0046.3.6	.046									▲/▲			▲/
R/LU105.0062.3.6	.062	.130	.224	.146	.787	1.378	.071	.236		▲/▲			▲/
R/LU105.0078.3.6	.078									▲/▲			▲/
R/LU105.0031.4.6	.031									▲/▲	Δ/		▲/
R/LU105.0046.4.6	.046									▲/▲			▲/
R/LU105.0062.4.6	.062	.130	.224	.146	.984	1.575	.071	.236		▲/▲	Δ/		▲/
R/LU105.0078.4.6	.078									▲/▲			▲/

- ▲ on stock Δ 4 weeks
- main recommendation
- alternative recommendation
- uncoated grades
- coated grades
- brazed/Cermet

P	○	●	●	●	●
M	●	●	●	●	●
K	●	●	●	●	●
S	●	●	●	●	●
N	●	●	●	●	●
H					

Dimensions in inch

Carbide grades

State R or L version

GROOVING (internal) $\geq \text{Ø} .268''$



INSERT Type

105

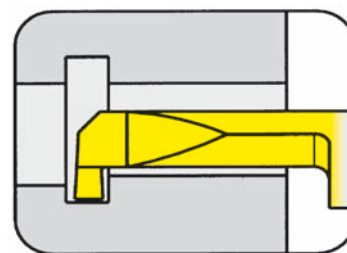

Bore Ø from .268"
 Depth of groove up to .098"

for use with Toolholder

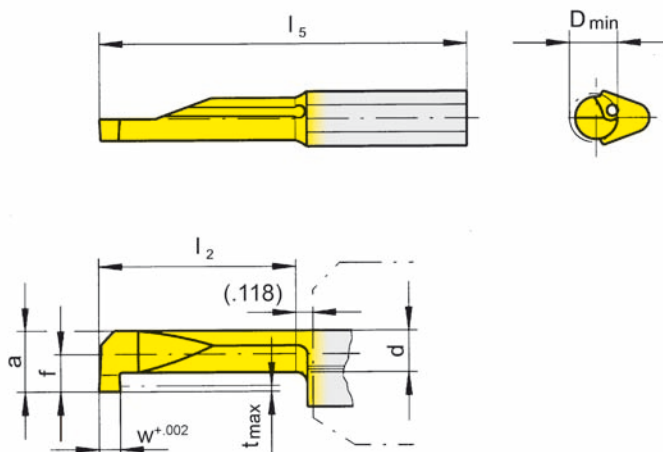

- Type BU105
 B105
 B105C
 B105KM
 BKT
 H105
 HC105
 VDI

R = right hand version shown

L = left hand version

Part number	w	f	a	d	l ₂	l ₅	t _{max}	D _{min}	Carbide grades				
									MG12	TN35	TI25	TF45	TH35
R/L105.0100.1.7	.039								▲/▲	▲/▲			▲/▲
R/L105.0150.1.7	.059	.157	.252	.146	.394	.984	.098	.268	▲/▲	▲/▲			▲/▲
R/L105.0200.1.7	.079								▲/▲	▲/▲			▲/▲
R/L105.0100.2.7	.039								▲/▲	▲/▲			▲/▲
R/L105.0150.2.7	.059	.157	.252	.146	.591	1.181	.098	.268	▲/▲	▲/▲			▲/▲
R/L105.0200.2.7	.079								▲/▲	▲/▲			▲/▲
R/L105.0100.3.7	.039								▲/▲	▲/▲			▲/▲
R/L105.0150.3.7	.059	.157	.252	.146	.787	1.378	.098	.268	▲/▲	▲/▲			▲/▲
R/L105.0200.3.7	.079								▲/▲	▲/▲			▲/▲
R/L105.0100.4.7	.039									▲/▲			▲/▲
R/L105.0150.4.7	.059	.157	.252	.146	.984	1.575	.098	.268		▲/▲			▲/▲
R/L105.0200.4.7	.079									▲/▲			▲/▲
R/L105.0100.5.7	.039										▲/▲		▲/▲
R/L105.0150.5.7	.059	.157	.252	.146	1.181	1.772	.098	.268		▲/▲			▲/▲
R/L105.0200.5.7	.079									▲/▲			▲/▲

- ▲ on stock Δ 4 weeks
- main recommendation
- alternative recommendation
- uncoated grades
- coated grades
- brazed/Cermet

P	○	●	●	●
M	●	●	●	●
K	●	●	●	●
S	●	●	●	●
N	●	●	●	●
H				

Carbide grades

Dimensions in inch

State R or L version

GROOVING (internal) $\geq \text{Ø} .268''$



A

INSERT Type

U105

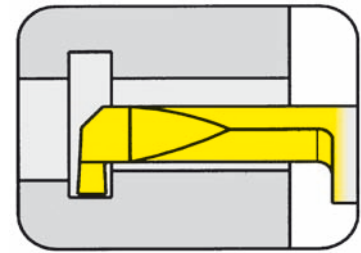

Bore Ø from $.268''$
Depth of groove up to $.098''$

for use with Toolholder

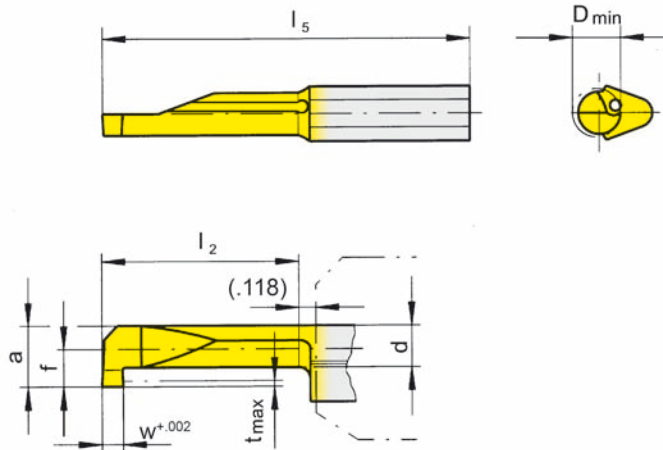

Type BU105
B105
B105C
B105KM
BKT
H105
HC105
VDI

R = right hand version shown

L = left hand version

Part number	w	f	a	d	l ₂	l ₅	t _{max}	D _{min}	Carbide grades				
									MG12	TN35	TI25	TF45	TH35
R/LU105.0031.1.7	.031								▲/	▲/▲			▲/
R/LU105.0046.1.7	.046									▲/▲	Δ/		▲/
R/LU105.0062.1.7	.062	.157	.252	.146	.394	.984	.098	.268		▲/▲			▲/
R/LU105.0078.1.7	.078									▲/▲			▲/
R/LU105.0031.2.7	.031									▲/▲			▲/
R/LU105.0046.2.7	.046									▲/▲			▲/
R/LU105.0062.2.7	.062	.157	.252	.146	.591	1.181	.098	.268		▲/▲			▲/
R/LU105.0078.2.7	.078									▲/▲			▲/
R/LU105.0031.3.7	.031									▲/▲			▲/
R/LU105.0046.3.7	.046									▲/▲			▲/
R/LU105.0062.3.7	.062	.157	.252	.146	.787	1.378	.098	.268		▲/▲			▲/
R/LU105.0078.3.7	.078									▲/▲			▲/
R/LU105.0031.4.7	.031									▲/▲			▲/
R/LU105.0046.4.7	.046									▲/Δ			▲/
R/LU105.0062.4.7	.062	.157	.252	.146	.984	1.575	.098	.268		▲/▲			▲/
R/LU105.0078.4.7	.078									▲/▲			▲/
R/LU105.0031.5.7	.031									▲/			▲/
R/LU105.0046.5.7	.046									▲/▲			▲/
R/LU105.0062.5.7	.062	.157	.252	.146	1.181	1.772	.098	.268		▲/▲			▲/
R/LU105.0078.5.7	.078									Δ/Δ			▲/

- ▲ on stock Δ 4 weeks
- main recommendation
- alternative recommendation
- uncoated grades
- coated grades
- brazed/Cermet

State R or L version

	P	M	K	S	N	H
State R or L version	○	●	●	●	●	●
Carbide grades	□	■	■	■	■	■

Dimensions in inch

Carbide grades

GROOVING (internal) $\geq \text{Ø} .197''$



INSERT Type

U105

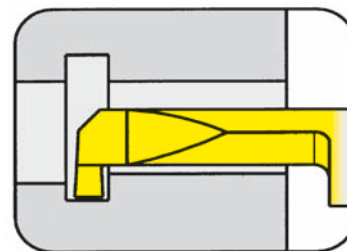

Bore Ø from .197"
 Depth of groove up to .039"

for use with Toolholder

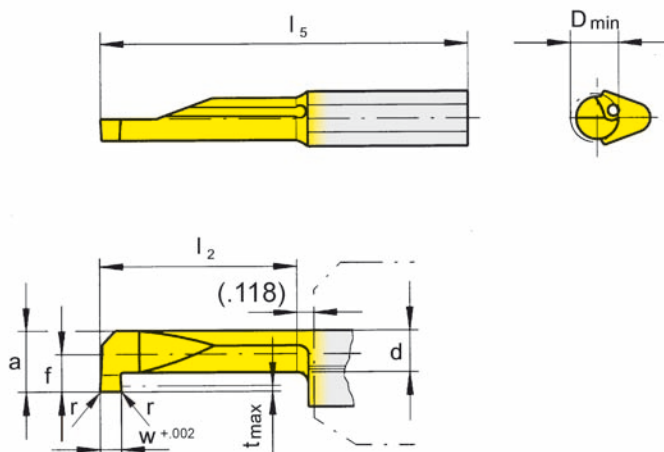

- Type BU105
 B105
 B105C
 B105KM
 BKT
 H105
 HC105
 VDI

with corner radius

R = right hand version shown

L = left hand version

Part number	w	f	a	d	l ₂	l ₅	t _{max}	D _{min}	r	Carbide grades				
										MG12	TN35	TI25	TF45	TH35
R/LU105.4604.1.5	.046										▲/			▲/
R/LU105.6204.1.5	.062	.091	.185	.138	.394	.984	.039	.197	.004		▲/			▲/
R/LU105.7804.1.5	.078										Δ/			Δ/
R/LU105.4604.3.5	.046										▲/▲			▲/
R/LU105.6204.3.5	.062	.091	.185	.138	.787	1.378	.039	.197	.004		▲/			▲/
R/LU105.7804.3.5	.078										▲/			Δ/
R/LU105.4604.5.5	.046													▲/
R/LU105.6204.5.5	.062	.091	.185	.138	1.181	1.772	.039	.197	.004		▲/			▲/
R/LU105.7804.5.5	.078										▲/			Δ/
										P	•			•
										M	•			•
										K	•			•
										S	•			•
										N	•			•
										H				

- ▲ on stock Δ 4 weeks
- main recommendation
- o alternative recommendation
- uncoated grades
- coated grades
- brazed/Cermet

Dimensions in inch
 State R or L version

GROOVING (internal) $\geq \text{Ø} .236''$



A

INSERT Type

U105

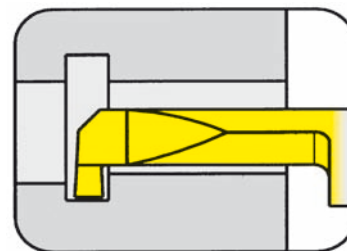

Bore Ø from $.236''$
Depth of groove up to $.071''$

for use with Toolholder

- Type BU105
B105
B105C
B105KM
BKT
H105
HC105
VDI

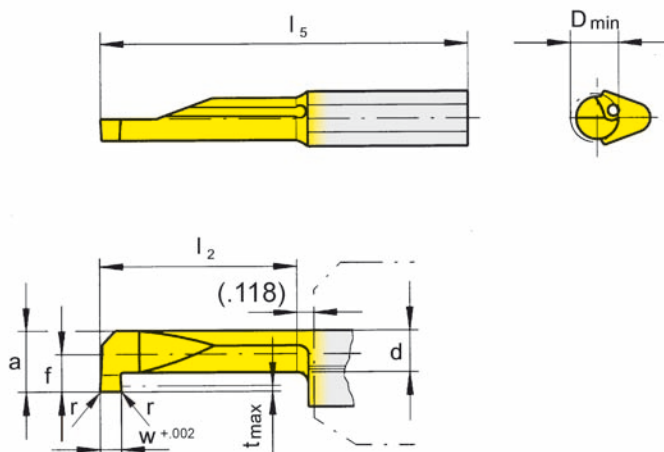

R = right hand version shown

L = left hand version

with corner radius

Part number	w	f	a	d	l ₂	l ₅	t _{max}	D _{min}	r	Carbide grades				
										MG12	TN35	TI25	TF45	TH35
R/LU105.4604.1.6	.046										▲/▲			▲/
R/LU105.6204.1.6	.062	.130	.224	.146	.394	.984	.071	.236	.004		▲/			▲/
R/LU105.7804.1.6	.078										▲/			▲/
R/LU105.4604.3.6	.046										▲/			▲/
R/LU105.6204.3.6	.062	.130	.224	.146	.787	1.378	.071	.236	.004		▲/			▲/
R/LU105.7804.3.6	.078										▲/Δ			▲/
R/LU105.4604.5.6	.046								.004		▲/			▲/
R/LU105.6204.5.6	.062	.130	.224	.146	1.181	1.772	.071	.236	.004		▲/			▲/
R/LU105.7804.5.6	.078								.004					▲/
R/LU105.7808.5.6	.078								.008		▲/			▲/
										P	•			•
										M	•			•
										K	•			•
										S	•			•
										N	•			•
										H				

- ▲ on stock Δ 4 weeks
- main recommendation
- o alternative recommendation
- uncoated grades
- coated grades
- brazed/Cermet

Dimensions in inch
State R or L version

Carbide grades

GROOVING (internal) ≥ Ø .268"



INSERT Type

U105

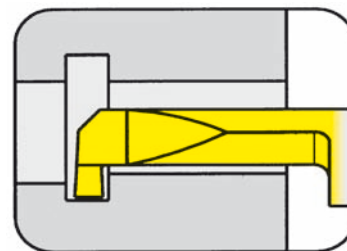

Bore Ø from .268"
Depth of groove up to .098"

for use with Toolholder

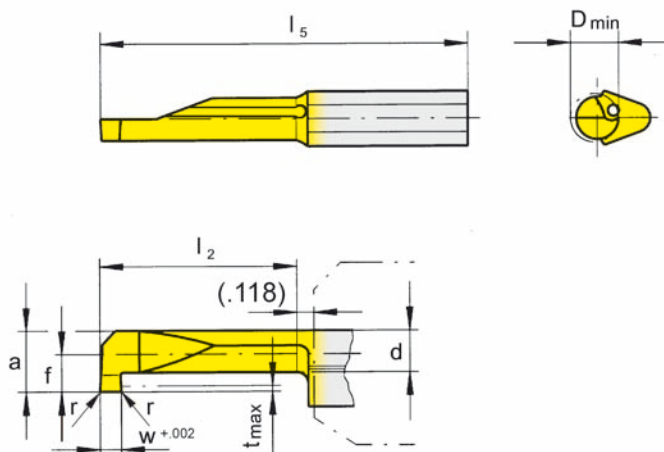

- Type BU105
B105
B105C
B105KM
BKT
H105
HC105
VDI

R = right hand version shown

L = left hand version

with corner radius

Part number	w	f	a	d	l ₂	l ₅	t _{max}	D _{min}	r	Carbide grades			
										MG12	TN35	TI25	TH35
R/LU105.4604.1.7	.046								.004		▲/		▲/
R/LU105.4608.1.7	.046								.008		▲/		▲/
R/LU105.6204.1.7	.062	.157	.252	.146	.394	.984	.098	.268	.004		▲/▲		▲/
R/LU105.6208.1.7	.062								.008		▲/		▲/
R/LU105.4604.2.7	.046								.004		▲/		▲/
R/LU105.4608.2.7	.046								.008		▲/		▲/
R/LU105.6204.2.7	.062	.157	.252	.146	.591	1.181	.098	.268	.004		▲/		▲/
R/LU105.6208.2.7	.062								.008		▲/		▲/
R/LU105.4604.3.7	.046								.004	▲/	▲/▲		▲/
R/LU105.4608.3.7	.046								.008		▲/		▲/
R/LU105.6204.3.7	.062	.157	.252	.146	.787	1.378	.098	.268	.004	▲/	▲/		▲/
R/LU105.6208.3.7	.062								.008		▲/		▲/
R/LU105.4604.4.7	.046								.004		▲/		▲/
R/LU105.4608.4.7	.046								.008		▲/		▲/
R/LU105.6204.4.7	.062	.157	.252	.146	.984	1.575	.098	.268	.004		▲/		▲/
R/LU105.6208.4.7	.062								.008		▲/		▲/
R/LU105.4604.5.7	.046								.004		▲/		▲/
R/LU105.4608.5.7	.046								.008		▲/		▲/
R/LU105.6204.5.7	.062	.157	.252	.146	1.181	1.772	.098	.268	.004		▲/		▲/
R/LU105.6208.5.7	.062								.008		▲/		▲/

- ▲ on stock Δ 4 weeks
- main recommendation
- alternative recommendation
- uncoated grades
- coated grades
- brazed/Cermet

State R or L version

P	○	●	■	■
M	●	●	■	■
K	●	●	■	■
S	●	●	■	■
N	●	●	■	■
H				

Dimensions in inch

Carbide grades

GROOVING (internal) $\geq \text{Ø} .268''$



A

INSERT Type

U105

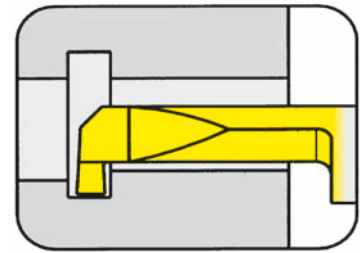

Bore Ø from $.268''$
Depth of groove up to $.098''$

for use with Toolholder

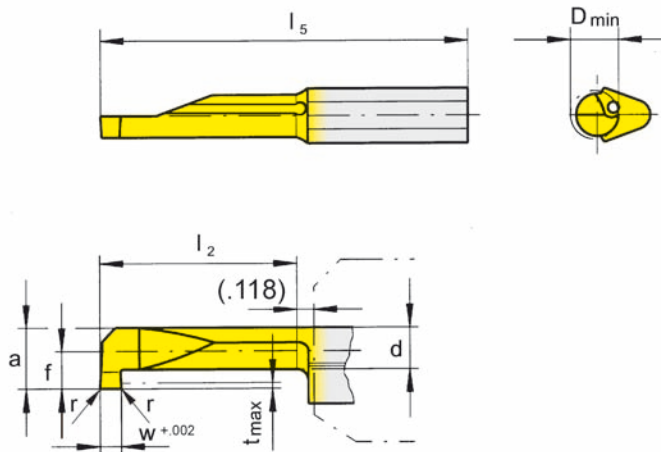

- Type BU105
B105
B105C
B105KM
BKT
H105
HC105
VDI

with corner radius

R = right hand version shown

L = left hand version

Part number	w	f	a	d	l ₂	l ₅	t _{max}	D _{min}	r	Carbide grades				
										MG12	TN35	TI25	TF45	TH35
R/LU105.7804.1.7 R/LU105.7808.1.7	.078	.157	.252	.146	.394	.984	.098	.268	.004 .008		▲/ ▲/			▲/ ▲/
R/LU105.7804.2.7 R/LU105.7808.2.7	.078	.157	.252	.146	.591	1.181	.098	.268	.004 .008		▲/ ▲/			▲/ ▲/
R/LU105.7804.3.7 R/LU105.7808.3.7	.078	.157	.252	.146	.787	1.378	.098	.268	.004 .008		▲/▲ ▲/			▲/ ▲/
R/LU105.7804.4.7 R/LU105.7808.4.7	.078	.157	.252	.146	.984	1.575	.098	.268	.004 .008		▲/ ▲/			▲/ ▲/
R/LU105.7804.5.7 R/LU105.7808.5.7	.078	.157	.252	.146	1.181	1.772	.098	.268	.004 .008		▲/ ▲/			▲/ ▲/

- ▲ on stock Δ 4 weeks
- main recommendation
- alternative recommendation

- uncoated grades
- coated grades
- brazed/Cermet

Dimensions in inch

State R or L version

P	●	●	●	●
M	●	●	●	●
K	●	●	●	●
S	●	●	●	●
N	●	●	●	●
H				

Carbide grades

GROOVING (internal) $\geq \text{Ø} .157''$



INSERT Type

105

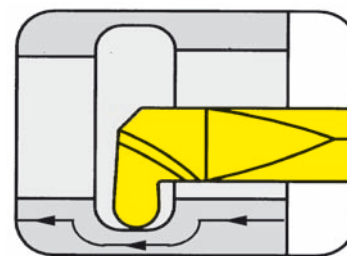

Bore Ø from $.157''$
Full radius $r .020 - .039''$

for use with Toolholder

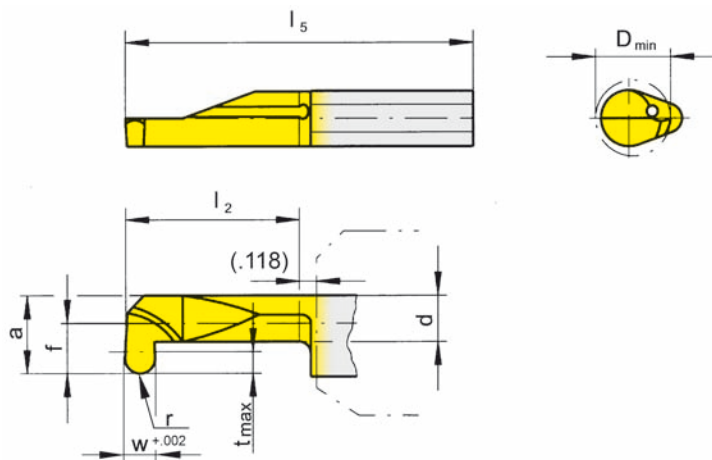

- Type BU105
B105
B105C
B105KM
BKT
H105
HC105
VDI

R = right hand version shown

L = left hand version

Full radius

Part number	w	f	a	d	l ₂	l ₅	t _{max}	D _{min}	r	Carbide grades				
										MG12	TN35	TI25	TF45	TH35
R/L105.0005.2.4	.039	.075	.146	.106	.591	1.181	.031	.157	.020		▲/▲			
R/L105.0005.3.5	.039								.020		▲/▲			
R/L105.0007.3.5	.059	.091	.185	.138	.787	1.378	.039	.197	.030		▲/▲			
R/L105.0010.3.5	.079								.039		▲/▲			
R/L105.0005.4.6	.039								.020		▲/▲			
R/L105.0007.4.6	.059	.130	.224	.146	.984	1.575	.071	.236	.030		▲/▲			
R/L105.0010.4.6	.079								.039		▲/▲			
R/L105.0005.5.7	.039								.020		▲/▲			
R/L105.0007.5.7	.059	.157	.252	.146	1.181	1.772	.098	.268	.030		▲/▲			
R/L105.0010.5.7	.079								.039		▲/▲			

- ▲ on stock Δ 4 weeks
- main recommendation
- alternative recommendation
- uncoated grades
- coated grades
- brazed/Cermet

P	●			
M	●			
K	●			
S	●			
N	●			
H				

Carbide grades

Dimensions in inch

State R or L version

INSERT Type

U105

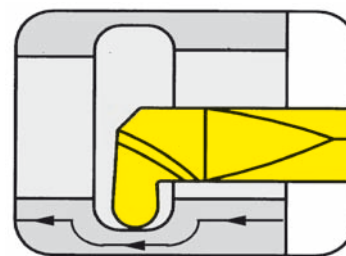

Bore Ø from $.157''$
Full radius r $.023 - .039''$

for use with Toolholder

- Type BU105
B105
B105C
B105KM
BKT
H105
HC105
VDI

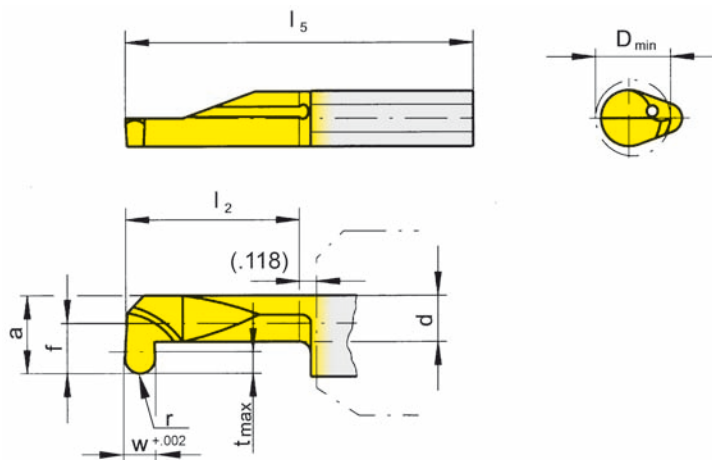

R = right hand version shown

L = left hand version

Full radius

Part number	w	f	a	d	l ₂	l ₅	t _{max}	D _{min}	r	Carbide grades				
										MG12	TN35	TI25	TF45	TH35
R/LU105.2346.2.4	.046	.075	.146	.106	.591	1.181	.031	.157	.023		▲/			▲/
R/LU105.2346.3.5	.046								.023		▲/	Δ/		▲/
R/LU105.3162.3.5	.062	.091	.185	.138	.787	1.378	.039	.197	.031		▲/			▲/
R/LU105.3978.3.5	.078								.039		▲/			▲/
R/LU105.2346.4.6	.046								.023		▲/▲			▲/
R/LU105.3162.4.6	.062	.130	.224	.146	.984	1.575	.071	.236	.031		▲/Δ			▲/
R/LU105.3978.4.6	.078								.039		▲/			▲/
R/LU105.2346.5.7	.046								.023		▲/▲			▲/
R/LU105.3162.5.7	.062	.157	.252	.146	1.181	1.772	.098	.268	.031		▲/▲			▲/
R/LU105.3978.5.7	.078								.039		▲/			▲/

- ▲ on stock Δ 4 weeks
- main recommendation
- alternative recommendation
- uncoated grades
- coated grades
- brazed/Cermet

	MG12	TN35	TI25	TF45	TH35
P	●	●	●	●	●
M	●	●	●	●	●
K	●	●	●	●	●
S	●	●	●	●	●
N	●	●	●	●	●
H	●	●	●	●	●

Carbide grades

Dimensions in inch

State R or L version

THREADING (internal) Partial profile



INSERT Type

105

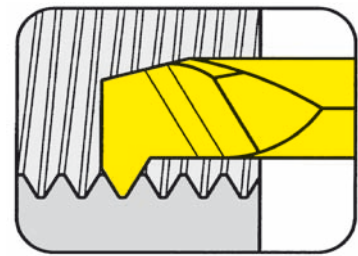

Bore Ø from Pitch .118" (3.0 mm)
P 0.25 mm

for use with Toolholder

- Type BU105
B105
B105C
B105KM
BKT
H105
HC105
VDI

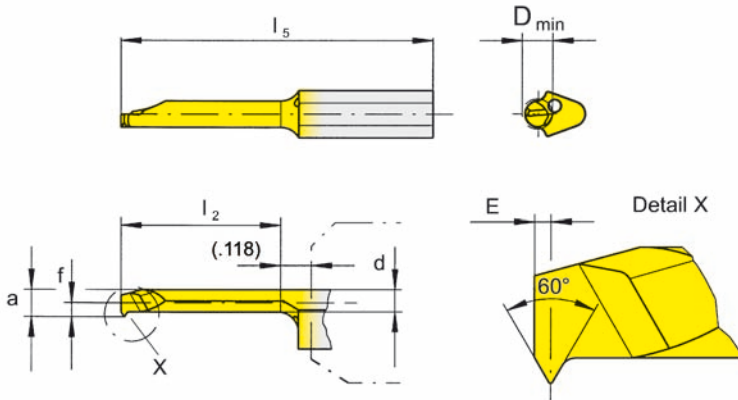

R = right hand version shown

L = left hand version

Metric ISO thread

Part number	P	E	f	a	d	l ₂	l ₅	D _{min}	Carbide grades					
									MG12	TN35	TI25	TF45	TH35	
R/L105.0102.2.3	0.25	0.3	1.4	2.7	2.2	15	30	3		▲/△				
									P	•				
									M	•				
									K	•				
									S	•				
									N	•				
									H					

- ▲ on stock Δ 4 weeks
- main recommendation
- o alternative recommendation
- uncoated grades
- coated grades
- brazed/Cermet

Dimensions in mm

State R or L version

INSERT Type

105

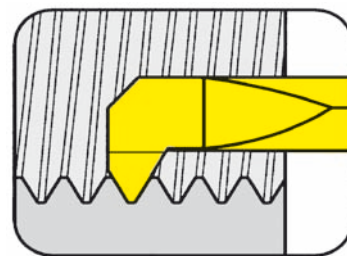

Bore Ø from Pitch .118" (3.0 mm)
P 0.35 mm

for use with Toolholder

- Type BU105
B105
B105C
B105KM
BKT
H105
HC105
VDI

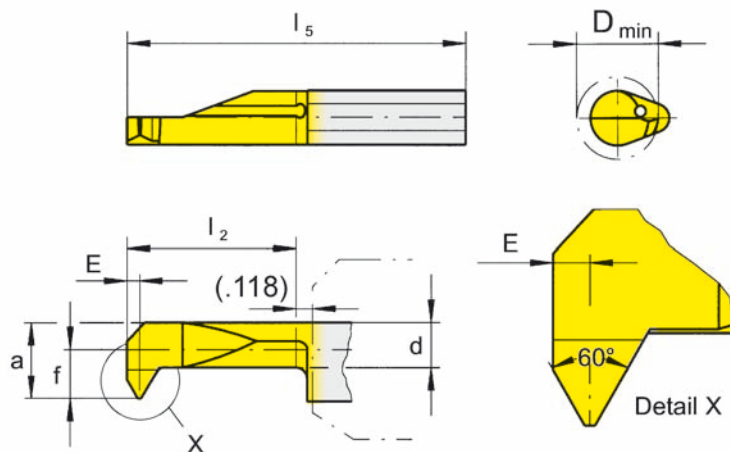

R = right hand version shown

L = left hand version

Metric ISO thread

Part number	P	E	f	a	d	I ₂	I ₅	D _{min}	Carbide grades					
									MG12	TN35	TI25	TF45	TH35	
R/L105.0203.1.3	0.35	0.3	1.4	2.7	2.1	10	25	3		▲/▲				
R/L105.0203.2.5	0.35	0.3	2.3	4.7	3.5	15	30	5		▲/▲				
									P	•				
									M	•				
									K	•				
									S	•				
									N	•				
									H					

- ▲ on stock Δ 4 weeks
- main recommendation
- o alternative recommendation
- uncoated grades
- coated grades
- brazed/Cermet

Dimensions in mm

State R or L version

Carbide grades

THREADING (internal) Partial profile



INSERT Type

105

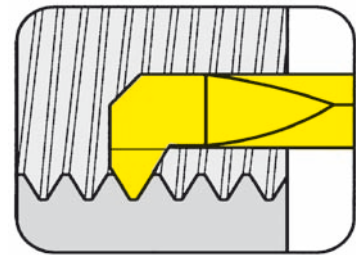

Bore Ø from Pitch .118" (3.0 mm)
P 0.50 mm

for use with Toolholder

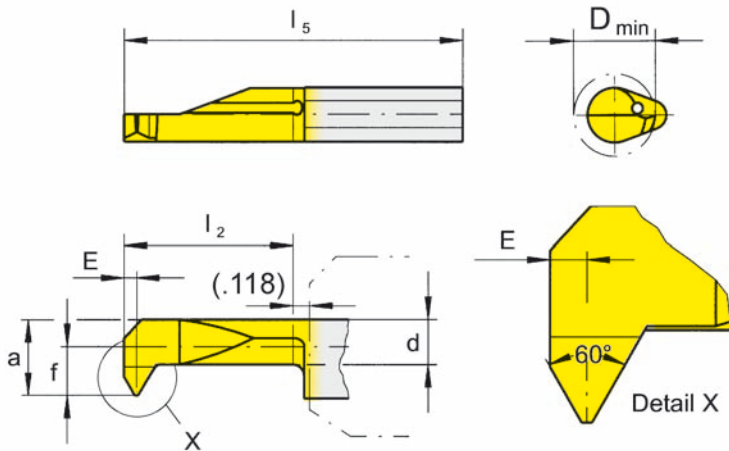

- Type
- BU105
 - B105
 - B105C
 - B105KM
 - BKT
 - H105
 - HC105
 - VDI

R = right hand version shown

L = left hand version

Metric ISO thread

Part number	P	E	f	a	d	I ₂	I ₅	D _{min}	Carbide grades					
									MG12	TN35	TI25	TF45	TH35	
R/L105.0205.2.3	0.5	0.35	1.4	2.7	2.1	15	30	3		▲/▲				
R/L105.0205.2.4	0.5	0.35	1.9	3.7	2.7	15	20	35	4	▲/▲	▲/▲			▲/▲
R/L105.0205.3.4											Δ/			
R/L105.0205.2.5	0.5	0.35	2.3	4.7	3.5	15	20	35	5	▲/▲	▲/▲			▲/▲
R/L105.0205.3.5											Δ/Δ			
R/L105.0205.4.5											▲/			
R/L105.0205.3.6	0.5	0.35	3.3	5.7	4.8	20	35	6		▲/				

▲ on stock Δ 4 weeks
 ● main recommendation
 ○ alternative recommendation
 □ uncoated grades
 ■ coated grades
 ■ brazed/Cermet

Dimensions in mm
 State R or L version

INSERT Type

105

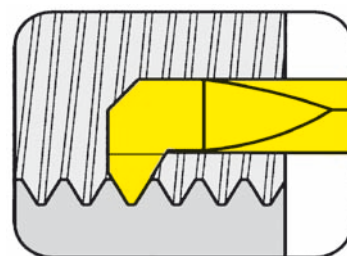

Bore Ø from Pitch .118" (3.0 mm)
P 0.50 - 0.75 mm

for use with Toolholder

- Type BU105
B105
B105C
B105KM
BKT
H105
HC105
VDI

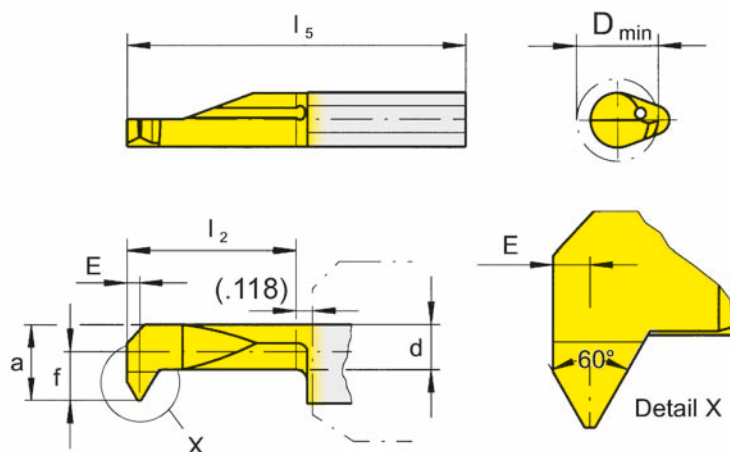

R = right hand version shown

L = left hand version

Metric ISO thread

Part number	P	P _{max}	E	f	a	d	I ₂	I ₅	D _{min}	Carbide grades				
										MG12	TN35	TI25	TF45	TH35
R/L105.0407.2.3	0.5	0.75	0.45	1.4	2.7	2.0	15	30	3		▲/			
R/L105.0407.1.4	0.5	0.75	0.45	1.9	3.7	2.7	10	25	4		▲/▲			
R/L105.0407.2.4							15	30			▲/▲			
R/L105.0407.3.4							20	35			▲/▲			
R/L105.0407.2.5	0.5	0.75	0.45	2.3	4.7	3.5	15	30	5		▲/▲		▲/▲	
R/L105.0407.3.5							20	35			▲/▲			
R/L105.0407.4.5							25	40			▲/▲			
R/L105.0407.3.6	0.5	0.75	0.45	3.3	5.7	4.7	20	35	6		▲/			

- ▲ on stock Δ 4 weeks
- main recommendation
- alternative recommendation
- uncoated grades
- coated grades
- brazed/Cermet

Dimensions in mm

State R or L version

P	●	●	●	●
M	●	●	●	●
K	●	●	●	●
S	●	●	●	●
N	●	●	●	●
H				

Carbide grades

THREADING (internal) Partial profile



INSERT Type

105

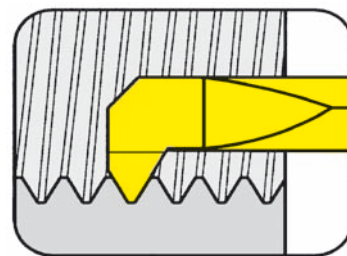

Bore Ø from Pitch .189" (4.8 mm)
P 1.00 - 1.50 mm

for use with Toolholder

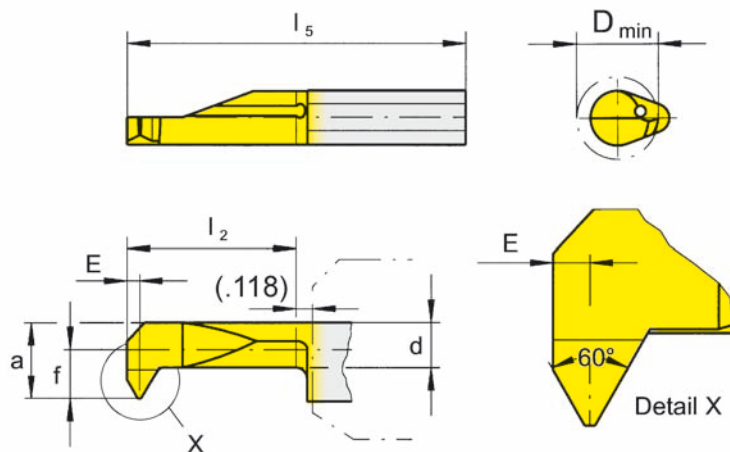

- Type BU105
B105
B105C
B105KM
BKT
H105
HC105
VDI

R = right hand version shown

L = left hand version

Metric ISO thread

Part number	P	E	f	a	d	I ₂	I ₅	D _{min}	MG12	TN35	TI25	TF45	TH35
									▲/△	▲/△			▲/△
R/L105.0510.2.5						15	30	4.8	▲/△	▲/△			▲/△
R/L105.0510.3.5	1.00	0.55	2.1	4.5	3.5	20	35			▲/△			
R/L105.0510.4.5						25	40			▲/△			
R/L105.0510.2.6	1.00	0.55				15	30	6.0		▲/△			▲/△
R/L105.0510.3.6	1.00	0.55				20	35			▲/△			
R/L105.0510.4.6	1.00	0.55				25	40			▲/△			
R/L105.0612.2.6	1.25	0.65	3.3	5.7	3.7	15	30	7.0	△/△	▲/△			▲/△
R/L105.0612.3.6	1.25	0.65				20	35			▲/△			
R/L105.0612.4.6	1.25	0.65				25	40			▲/△			
R/L105.0815.2.7						15	30	7.0		▲/△			▲/△
R/L105.0815.3.7	1.50	0.75	4.0	6.4	3.7	20	35			▲/△			
R/L105.0815.4.7						25	40			▲/△			
									P	o	•	•	•
									M	•	•	•	•
									K	•	•	•	•
									S	•	•	•	•
									N	•	•	•	•
									H				

- ▲ on stock △ 4 weeks
- main recommendation
- o alternative recommendation
- uncoated grades
- coated grades
- brazed/Cermet

Dimensions in mm

State R or L version

Carbide grades

THREADING (internal) Partial profile



A

INSERT Type

105

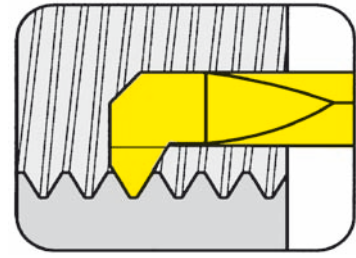

Bore Ø from
Threads per inch

.157"
16 - 40

for use with Toolholder

Type BU105
B105
B105C
B105KM
BKT
H105
HC105
VDI

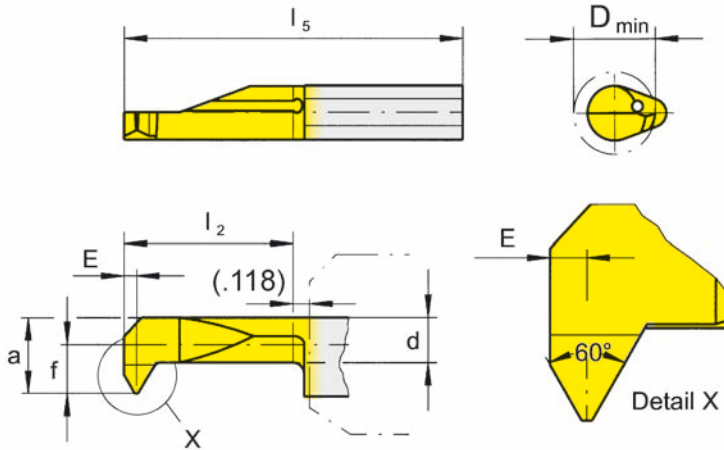

R = right hand version shown

L = left hand version

Thread UN

Part number	Threads per Inch	E	f	a	d	I ₂	I ₅	D _{min}	MG12	TN35	TI25	TF45	TH35
R/L105.3240.2.4	32 - 40	.018	.075	.146	.106	.591	1.181	.157		▲/▲	▲/	▲/▲	
R/L105.2428.2.5	24 - 28	.022	.091	.185	.138	.591	1.181	.197		▲/▲	▲/		
R/L105.3240.2.5	32 - 40	.018	.091	.185	.138	.591	1.181	.197		▲/▲	▲/	▲/▲	
R/L105.1620.2.5	16 - 20	.028	.130	.224	.146	.591	1.181	.197					▲/▲
R/L105.1620.3.5	16 - 20	.028	.130	.224	.146	.787	1.378	.197					▲/▲
R/L105.1620.2.6	16 - 20	.028	.130	.224	.146	.591	1.181	.236		▲/▲			
R/L105.1620.3.6	16 - 20	.028	.130	.224	.146	.787	1.378	.236		▲/			
R/L105.1620.4.6	16 - 20	.028	.130	.224	.146	.984	1.575	.236		▲/			
R/L105.2428.2.6	24 - 28	.022	.130	.224	.146	.591	1.181	.236		▲/▲	▲/		
R/L105.2428.3.6	24 - 28	.022	.130	.224	.146	.787	1.378	.236		▲/			
R/L105.2428.4.6	24 - 28	.022	.130	.224	.146	.984	1.575	.236		▲/▲			

- ▲ on stock Δ 4 weeks
- main recommendation
- alternative recommendation
- uncoated grades
- coated grades
- brazed/Cermet

Dimensions in inch

State R or L version

	P	M	K	S	N	H
MG12	●	●	●	●	●	●
TN35	●	●	●	●	●	●
TI25	●	●	●	●	●	●
TF45	●	●	●	●	●	●
TH35	●	●	●	●	●	●

Carbide grades

INSERT Type

105

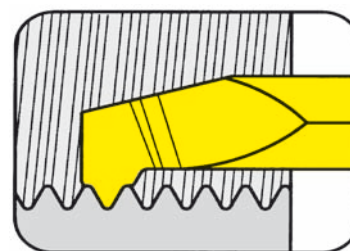

Bore Ø from Pitch .094" (2.4 mm)
P 0.50 - 1.25 mm

for use with Toolholder

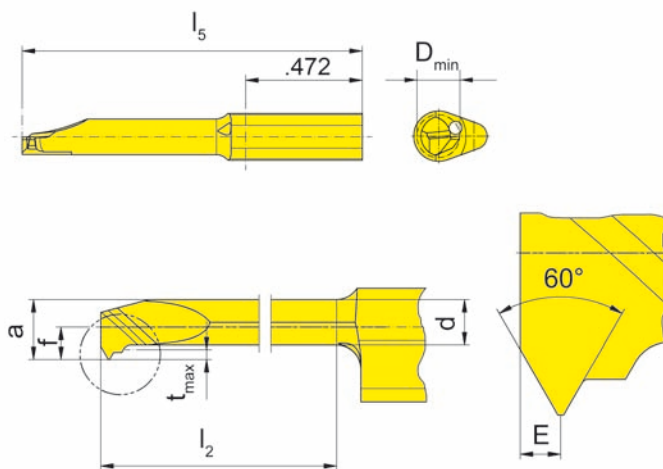

- Type
- BU105
 - B105
 - B105C
 - B105KM
 - BKT
 - H105
 - HC105
 - VDI

R = right hand version shown

L = left hand version

Metric ISO thread

Part number	P	E	f	a	d	l ₂	l ₅	D _{min}	Carbide grades				
									MG12	TN35	TI25	TF45	TH35
R/L105.VPM3.2.3 R/L105.VPM3.4.3	0.50	0.3	1.4	2.2	1.65	9 12	25 35	2.4					▲/▲
R/L105.VPM4.2.4 R/L105.VPM4.3.4									0.70	0.4	1.5	2.9	2.10
R/L105.VPM5.2.5 R/L105.VPM5.4.5	0.80	0.5	2.0	3.7	2.80	15 25	30 40	4.1					▲/▲
R/L105.VPM6.3.6 R/L105.VPM6.4.6 R/L105.VPM6.5.6									1.00	0.5	2.4	4.5	3.40
R/L105.VPM8.3.8 R/L105.VPM8.5.8	1.25	0.7	3.8	6.2	4.70	20 30	35 45	6.6					▲/▲

- ▲ on stock Δ 4 weeks
- main recommendation
- alternative recommendation
- uncoated grades
- coated grades
- brazed/Cermet

P				●
M				●
K				●
S				●
N				●
H				

Carbide grades

Dimensions in mm

State R or L version

THREADING (internal) Partial profile



A

INSERT Type

105

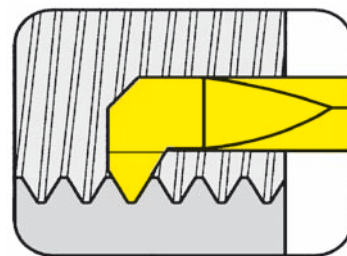

Bore Ø from .236"
Threads per inch 18 - 27

for use with Toolholder

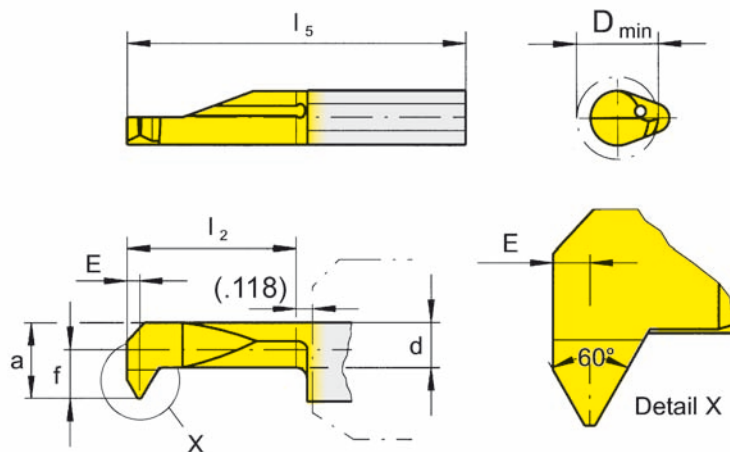

- Type
- BU105
 - B105
 - B105C
 - B105KM
 - BKT
 - H105
 - HC105
 - VDI

R = right hand version shown

L = left hand version

Thread NPT

Part number	Threads per Inch	E	f	a	d	I ₂	I ₅	D _{min}	Carbide grades					
									MG12	TN35	TI25	TF45	TH35	
R/L105.NP18.2.6	18	.039				.591	1.181	.236		▲/▲				
R/L105.NP18.3.6	18	.039				.787	1.378			Δ/Δ				
R/L105.NP18.4.6	18	.039				.984	1.575			Δ/Δ				
R/L105.NP27.2.6	27	.031	.130	.224	.146	.591	1.181			▲/▲				
R/L105.NP27.3.6	27	.031				.787	1.378			Δ/Δ				
R/L105.NP27.4.6	27	.031				.984	1.575			Δ/Δ				
<ul style="list-style-type: none"> ▲ on stock Δ 4 weeks ● main recommendation ○ alternative recommendation □ uncoated grades ■ coated grades ■ brazed/Cermet 										P	•			
										M	•			
										K	•			
										S	•			
										N	•			
										H				

Dimensions in inch

Carbide grades

State R or L version

THREADING (internal) Full profile



INSERT Type

105

Whitworth thread

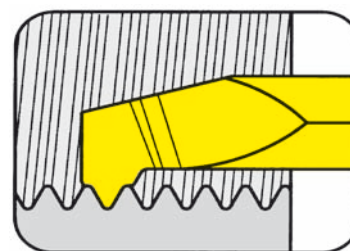

Bore Ø from .157"
Threads per inch 19 - 28

for use with Toolholder

- Type BU105
B105
B105C
B105KM
BKT
H105
HC105
VDI

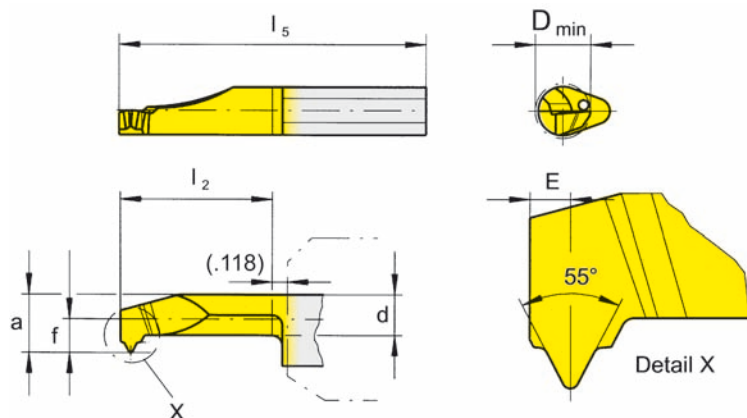

R = right hand version shown

Thread BSW/BSF

Part number	Threads per Inch	E	f	a	d	l ₂	l ₅	D _{min}	Carbide grades					
									MG12	TN35	TI25	TF45	TH35	
R105.5520.2.4	20	.039	.075	.146	.098	.591	1.181	.157		Δ				
R105.5519.3.6	19	.039								▲				
R105.5522.3.6	22	.039								Δ				
R105.5524.3.6	24	.031	.130	.224	.146	.787	1.378	.236		Δ				
R105.5526.3.6	26	.031								Δ				
R105.5528.3.6	28	.031								Δ				
										P	•			
										M	•			
										K	•			
										S	•			
										N	•			
										H				

- ▲ on stock Δ 4 weeks
- main recommendation
- o alternative recommendation
- uncoated grades
- coated grades
- brazed/Cermet

Dimensions in inch

Carbide grades

THREADING (internal) Full profile



INSERT Type

105

Whitworth thread

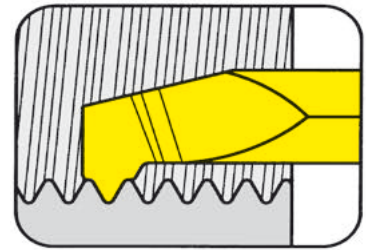

Bore Ø from
Threads per inch

.197"
19 - 28

for use with Toolholder

Type BU105
B105
B105C
B105KM
BKT
H105
HC105
VDI

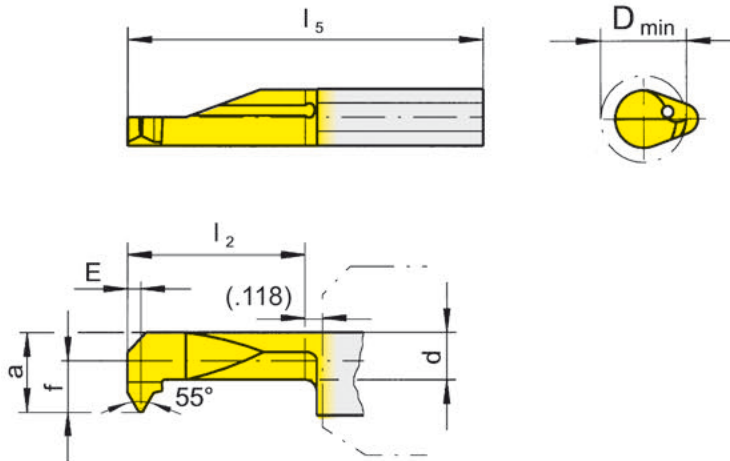

R = right hand version shown

L = left hand version

Thread BSW/BSF

Part number	Threads per Inch	E	f	a	d	I ₂	I ₅	D _{min}	Carbide grades					
									MG12	TN35	TI25	TF45	TH35	
R/L105.5524.2.5	24									▲/▲				
R/L105.5526.2.5	26	.031	.091	.185	.138	.591	1.181	.197		▲/▲				
R/L105.5528.2.5	28									▲/▲				
R/L105.5524.2.6	24									▲/▲				
R/L105.5526.2.6	26	.031	.130	.224	.146	.591	1.181	.236		▲/				
R/L105.5528.2.6	28									▲/▲				
R/L105.5519.2.6	19									▲/▲				
R/L105.5520.2.6	20	.039	.130	.224	.146	.591	1.181	.236		▲/▲				
R/L105.5522.2.6	22									▲/▲				
▲ on stock ▲ 4 weeks ● main recommendation ○ alternative recommendation □ uncoated grades ■ coated grades ■ brazed/Cermet										P	•			
										M	•			
										K	•			
										S	•			
										N	•			
										H				

Dimensions in inch

State R or L version

Carbide grades

INSERT Type

U105

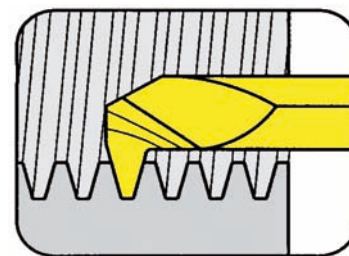

Bore Ø from .197"
Threads per inch 10 - 16

for use with Toolholder

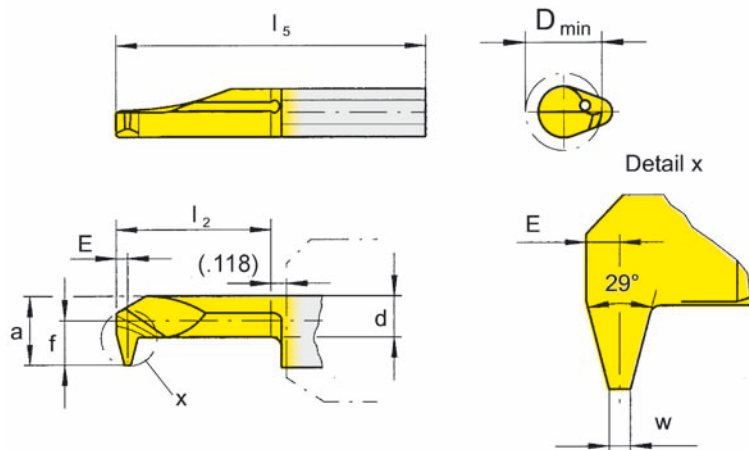

- Type BU105
B105
B105C
B105KM
BKT
H105
HC105
VDI

ACME / Stub ACME
thread

R = right hand version shown

L = left hand version

Part number	Threads per Inch	E	f	a	d	I ₂	I ₅	D _{min}	Carbide grades					
									MG12	TN35	TI25	TF45	TH35	
R/LU105.AC16.2.5 R/LU105.AC16.4.5	16	.028	.079	.173	.122	.591 .984	1.181 1.575	.197		▲/	▲/			▲/
R/LU105.AC14.2.6 R/LU105.AC14.4.6	14	.035	.130	.224	.169	.591 .984	1.181 1.575	.236		▲/				▲/
R/LU105.AC12.3.7 R/LU105.AC12.5.7	12	.039	.157	.252	.189	.787 1.181	1.378 1.772	.276		▲/				▲/
R/LU105.AC10.3.7	10	.039	.157	.252	.173	.787	1.378	.276		▲/				▲/

- ▲ on stock Δ 4 weeks
- main recommendation
- alternative recommendation
- uncoated grades
- coated grades
- brazed/Cermet

P	●	●	●	●
M	●	●	●	●
K	●	●	●	●
S	●	●	●	●
N	●	●	●	●
H				

Carbide grades

Dimensions in inch

State R or L version

INSERT Type

U105

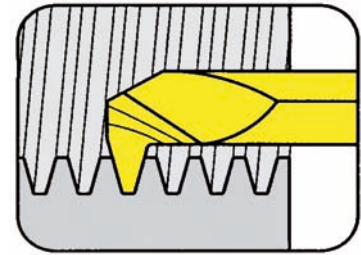

Bore Ø from .197"
Threads per inch 10 - 16

for use with Toolholder

- Type BU105
B105
B105C
B105KM
BKT
H105
HC105
VDI

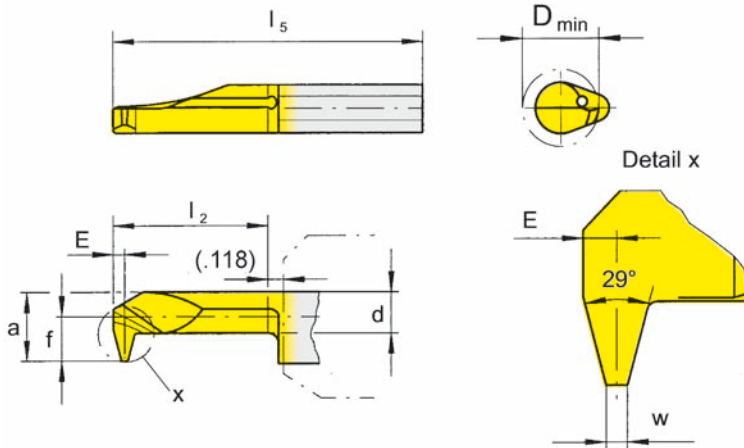

R = right hand version shown

L = left hand version

ACME / Stub ACME thread

Part number	Threads per Inch	E	f	a	d	I ₂	I ₅	D _{min}	Carbide grades				
									MG12	TN35	TI25	TF45	TH35
R/LU105.SA16.2.5 R/LU105.SA16.4.5	16	.028	.091	.185	.142	.591 .984	1.181 1.575	.197		▲/			▲/
R/LU105.SA14.2.6 R/LU105.SA14.4.6	14	.035	.131	.224	.177	.591 .984	1.181 1.575	.236		▲/			▲/
R/LU105.SA12.3.7 R/LU105.SA12.5.7	12	.039	.157	.252	.201	.787 1.181	1.378 1.772	.276		▲/	Δ/		▲/
R/LU105.SA10.3.7	10	.039	.157	.252	.193	.787	1.378	.276		Δ/			▲/
▲ on stock Δ 4 weeks ● main recommendation ○ alternative recommendation □ uncoated grades ■ coated grades ■ brazed/Cermet									P	●	●	●	●
									M	●	●	●	●
									K	●	●	●	●
									S	●	●	●	●
									N	●	●	●	●
									H				

Dimensions in inch

State R or L version

Carbide grades

INSERT Type

105

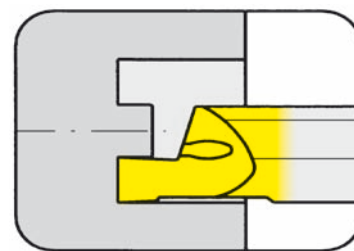

from outer groove \varnothing .197"
 Depth of groove up to .197"
 Width of groove up to .079"

for use with Toolholder

- Type BU105
 B105
 B105C
 B105KM
 BKT
 H105
 HC105
 VDI

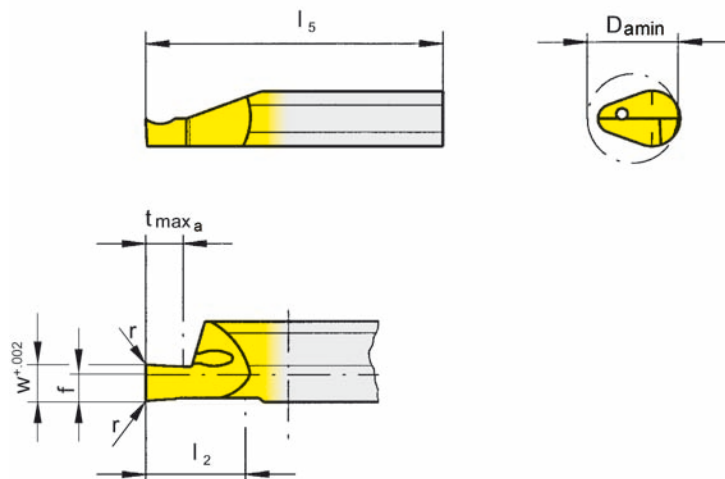

R = right hand version shown

L = left hand version

Part number	w	f	l ₂	l ₅	t _{max a}	D _{a min}	r	Carbide grades				
								MG12	TN35	TI25	TF45	TH35
R/L105.0510.1.8	.039				.079			▲/△		▲/▲		
R/L105.0515.1.8	.059	.079	.394	.984	.118	.197	.002	▲/△		▲/▲		
R/L105.0520.1.8	.079				.197			▲/△		▲/▲		
R/L105.0510.2.8	.039				.079			△/△		▲/▲		
R/L105.0515.2.8	.059	.079	.591	1.378	.118	.197	.002	△/△		▲/▲		
R/L105.0520.2.8	.079				.197			▲/▲		▲/▲		
								P	○	●	●	●
								M	●	●	●	●
								K	●	●	●	●
								S	●	●	●	●
								N	●	●	●	●
								H				

- ▲ on stock △ 4 weeks
- main recommendation
- alternative recommendation
- uncoated grades
- coated grades
- brazed/Cermet

Dimensions in inch
 State R or L version

Carbide grades

INSERT Type

105

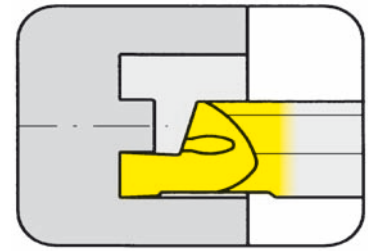

from outer groove \varnothing	.236"
Depth of groove up to	.197"
Width of groove up to	.079"

for use with Toolholder

- Type BU105
 B105
 B105C
 B105KM
 BKT
 H105
 HC105
 VDI

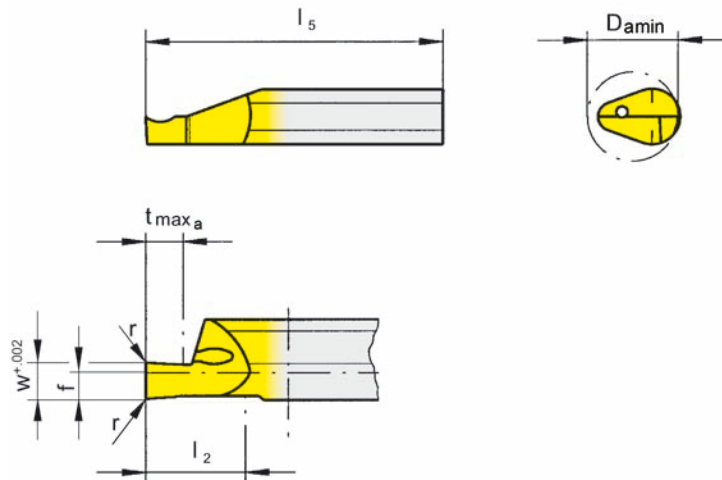

R = right hand version shown

L = left hand version

Part number	w	f	l ₂	l ₅	t _{max a}	D _{a min}	r	MG12	TN35	TI25	TF45	TH35
R/L105.0610.1.8	.039				.079			▲/▲		▲/▲		
R/L105.0615.1.8	.059	.079	.394	.984	.118	.236	.002	Δ/Δ		▲/▲		
R/L105.0620.1.8	.079				.197			▲/Δ		▲/▲		
R/L105.0610.2.8	.039				.079			Δ/Δ		Δ/▲		
R/L105.0615.2.8	.059	.079	.591	1.378	.118	.236	.002	Δ/		▲/Δ		
R/L105.0620.2.8	.079				.197			Δ/Δ		▲/▲		
								P	○	●		
								M	●	●		
								K	●	●		
								S	●	●		
								N	●	●		
								H				

- ▲ on stock Δ 4 weeks
- main recommendation
- alternative recommendation
- uncoated grades
- coated grades
- brazed/Cermet

Dimensions in inch

State R or L version

Carbide grades

INSERT Type

105

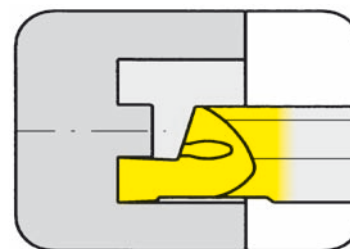

from outer groove Ø .315"
 Depth of groove up to .236"
 Width of groove up to .118"

for use with Toolholder

- Type BU105
 B105
 B105C
 B105KM
 BKT
 H105
 HC105
 VDI

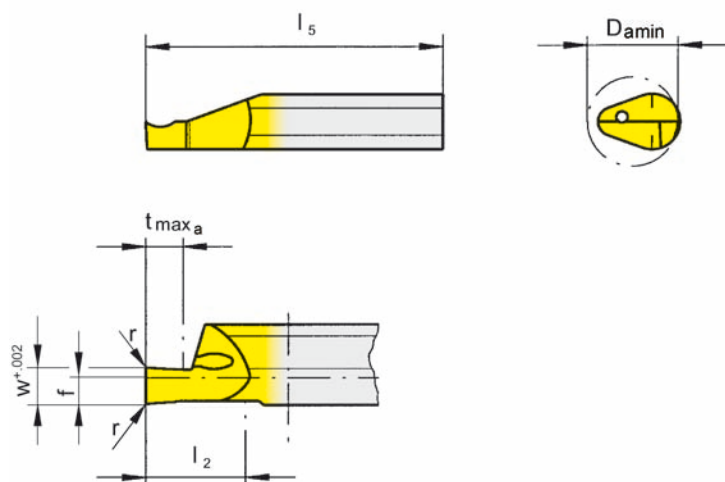

R = right hand version shown

L = left hand version

Part number	w	f	l ₂	l ₅	t _{max a}	D _{a min}	r	Carbide grades						
								MG12	TN35	TI25	TF45	TH35		
R/L105.0810.1.8	.039				.079					▲▲				
R/L105.0815.1.8	.059				.118					▲▲				
R/L105.0820.1.8	.079	.079	.394	.984	.157	.315	.006			▲▲				
R/L105.0825.1.8	.098				.197					▲▲				
R/L105.0830.1.8	.118				.236					▲▲				
R/L105.0810.2.8	.039				.079					▲▲				
R/L105.0815.2.8	.059				.118					▲▲				
R/L105.0820.2.8	.079	.079	.591	1.378	.157	.315	.006			▲▲				
R/L105.0825.2.8	.098				.197					▲▲				
R/L105.0830.2.8	.118				.236					▲▲				
								P		●				
								M		●				
								K		●				
								S		●				
								N		●				
								H						

- ▲ on stock Δ 4 weeks
- main recommendation
- alternative recommendation
- uncoated grades
- coated grades
- brazed/Cermet

Dimensions in inch

Carbide grades

State R or L version

INSERT Type

U105

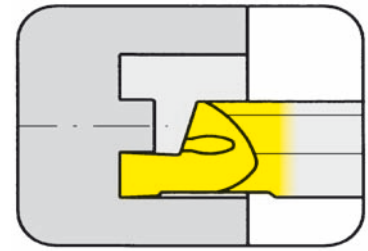

from outer groove \varnothing .315"
 Depth of groove up to .236"
 Width of groove up to .125"

for use with Toolholder

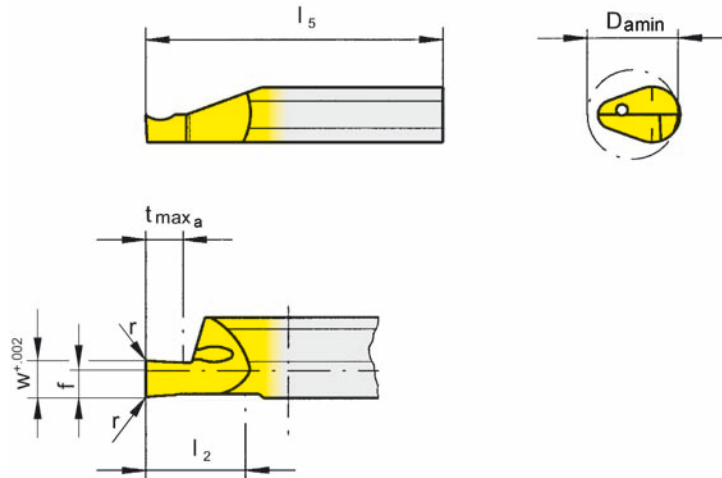

- Type BU105
 B105
 B105C
 B105KM
 BKT
 H105
 HC105
 VDI

R = right hand version shown

L = left hand version

Part number	w	f	l ₂	l ₅	t _{max a}	D _{a min}	r	Carbide grades				
								MG12	TN35	TI25	TF45	TH35
R/LU105.0846.1.8	.046				.098					▲▲		▲/
R/LU105.0862.1.8	.062				.118					▲▲		▲/
R/LU105.0878.1.8	.078	.079	.394	.984	.157	.315	.006			▲▲		▲/
R/LU105.0894.1.8	.094				.197					▲▲		▲/
R/LU105.0812.1.8	.125				.236					▲▲		▲/
R/LU105.0846.2.8	.046				.098					▲▲		▲/
R/LU105.0862.2.8	.062				.118					▲▲		▲/
R/LU105.0878.2.8	.078	.079	.591	1.378	.157	.315	.006			▲▲		▲/
R/LU105.0894.2.8	.094				.197					▲▲		▲/
R/LU105.0812.2.8	.125				.236					▲▲		▲/
								P		●		●
								M		●		●
								K		●		●
								S		●		●
								N		●		●
								H				

- ▲ on stock Δ 4 weeks
- main recommendation
- alternative recommendation
- uncoated grades
- coated grades
- brazed/Cermet

Dimensions in inch

State R or L version

Carbide grades

INSERT Type

U105

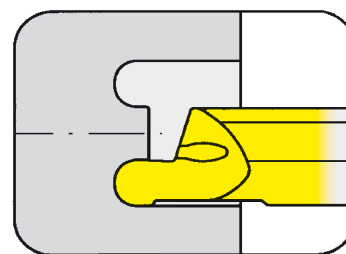

from outer groove \varnothing .315"
 Depth of groove up to .236"
 Width of groove up to .125"

for use with Toolholder

- Type BU105
 B105
 B105C
 B105KM
 BKT
 H105
 HC105
 VDI

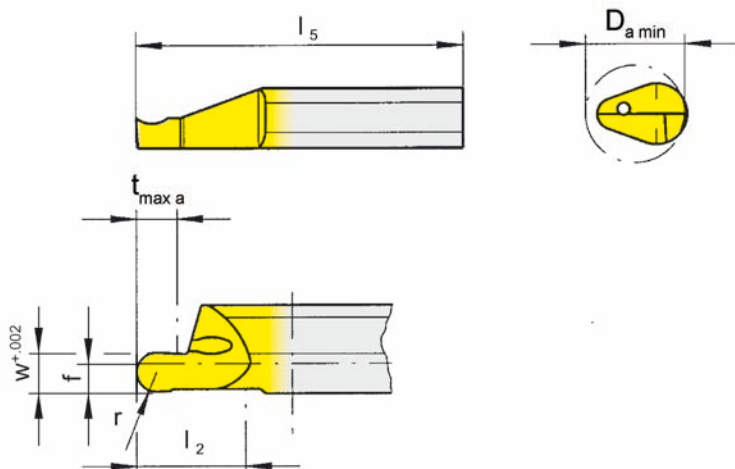

R = right hand version shown

L = left hand version

Full radius

Part number	w	f	l ₂	l ₅	t _{max a}	D _{a min}	r	Carbide grades				
								MG12	TN35	TI25	TF45	TH35
R/LU105.FF46.1.8	.046				.098		.023			▲▲		▲/
R/LU105.FF62.1.8	.062				.118		.031			▲▲		▲/
R/LU105.FF78.1.8	.078	.079	.394	.984	.157	.315	.039			▲▲		▲/
R/LU105.FF94.1.8	.094				.197		.047			▲/		▲/
R/LU105.FF12.1.8	.125				.236		.062			▲▲		▲/
R/LU105.FF46.2.8	.046				.098		.023			▲/		▲/
R/LU105.FF62.2.8	.062				.118		.031			▲/		▲/
R/LU105.FF78.2.8	.078	.079	.591	1.378	.157	.315	.039			▲/		▲/
R/LU105.FF94.2.8	.094				.197		.047			▲/		▲/
R/LU105.FF12.2.8	.125				.236		.062			▲/		▲/
								P		•		•
								M		•		•
								K		•		•
								S		•		•
								N		•		•
								H				

- ▲ on stock Δ 4 weeks
- main recommendation
- o alternative recommendation
- uncoated grades
- coated grades
- brazed/Cermet

Dimensions in inch
 State R or L version

Carbide grades

INSERT Type

105

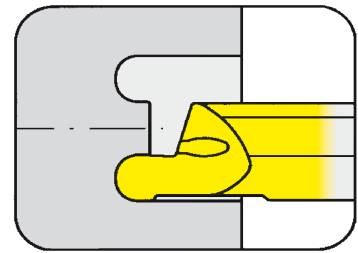

from outer groove \varnothing .315"
 Depth of groove up to .236"
 Width of groove up to .118"

for use with Toolholder

- Type BU105
 B105
 B105C
 B105KM
 BKT
 H105
 HC105
 VDI

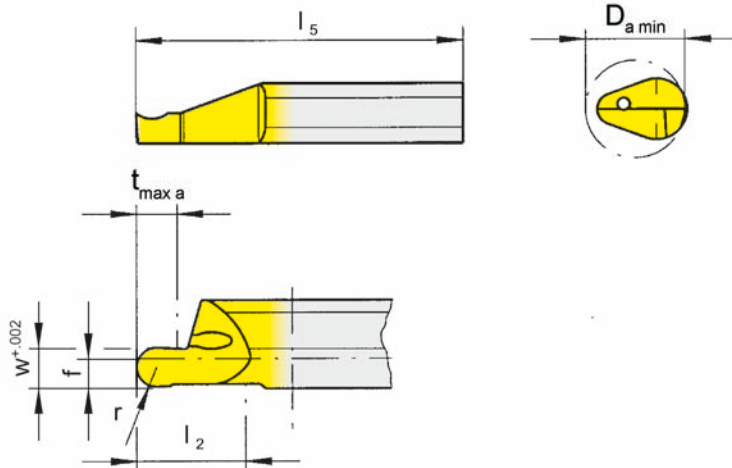

R = right hand version shown

L = left hand version

Full radius

Part number	w	f	l ₂	l ₅	t _{max a}	D _{a min}	r	Carbide grades				
								MG12	TN35	TI25	TF45	TH35
R/L105.8V10.1.8	.039				.079		.020			▲▲		
R/L105.8V16.1.8	.063				.118		.031			▲▲		
R/L105.8V20.1.8	.079	.079	.394	.984	.157	.315	.039			▲▲		
R/L105.8V25.1.8	.098				.197		.049			▲▲		
R/L105.8V30.1.8	.118				.236		.059			▲▲		
R/L105.8V10.2.8	.039				.079		.020			▲▲		
R/L105.8V16.2.8	.063				.118		.031			▲▲		
R/L105.8V20.2.8	.079	.079	.591	1.378	.157	.315	.039			▲▲		
R/L105.8V25.2.8	.098				.197		.049			▲/▲		
R/L105.8V30.2.8	.118				.236		.059			▲/▲		
								P		•		
								M		•		
								K		•		
								S		•		
								N		•		
								H				

- ▲ on stock Δ 4 weeks
- main recommendation
- o alternative recommendation
- uncoated grades
- coated grades
- brazed/Cermet

Dimensions in inch
 State R or L version

Carbide grades

INSERT Type

105

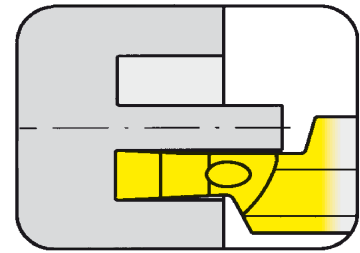

from outer groove \varnothing	.315"
Depth of groove up to	.236"
Width of groove up to	.118"

for use with Toolholder

- Type BU105
 B105
 B105C
 B105KM
 BKT
 H105
 HC105
 VDI

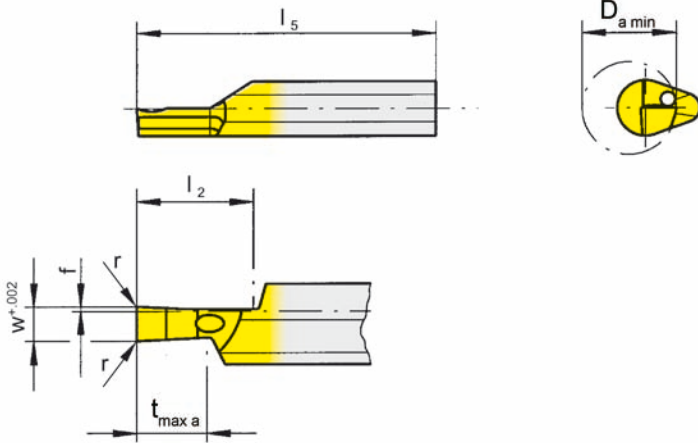

R = right hand version shown

L = left hand version

Part number	w	f	l ₂	l ₅	t _{max a}	D _{a min}	r	Carbide grades					
								MG12	TN35	TI25	TF45	TH35	
R/L105.0810.1.9	.039				.079					▲▲			
R/L105.0815.1.9	.059				.118					▲▲			
R/L105.0820.1.9	.079	.016	.394	.984	.157	.315	.006			▲▲			
R/L105.0825.1.9	.098				.197					▲▲			
R/L105.0830.1.9	.118				.236					▲▲			
								P		●			
								M		●			
								K		●			
								S		●			
								N		●			
								H					

- ▲ on stock Δ 4 weeks
- main recommendation
- alternative recommendation
- uncoated grades
- coated grades
- brazed/Cermet

Dimensions in inch
 State R or L version

Carbide grades

INSERT Type

105

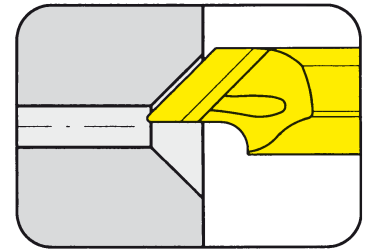

Angle of chamfer 45° / 60°
Width of chamfer up to .157"

for use with Toolholder

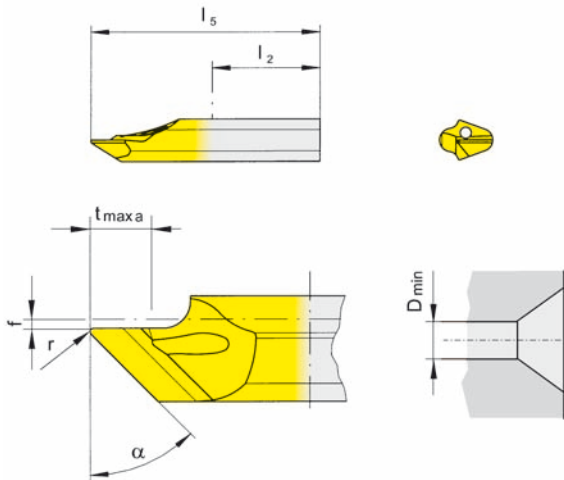

- Type BU105
B105
B105C
B105KM
BKT
H105
HC105
VDI

R = right hand version shown

L = left hand version

Part number	α	f	l ₂	l ₅	t _{max a}	D _{min}	r	Carbide grades				
								MG12	TN35	TI25	TF45	TH35
R/L105.0045.0.1	45°	.020	.472	.787	.138	.039	.008		▲/▲		/▲	
R/L105.0045.1.1									▲/▲			
R/L105.0060.0.1	60°	.020	.472	.787	.157	.039	.008				/▲	
R/L105.0060.1.1										▲/▲		
								P	•	•	•	•
								M	•	•	•	•
								K	•	•	•	•
								S	•	•	•	•
								N	•	•	•	•
								H				

- ▲ on stock Δ 4 weeks
- main recommendation
- o alternative recommendation
- uncoated grades
- coated grades
- brazed/Cermet

Dimensions in inch

State R or L version

Carbide grades

TOOLHOLDER Type

BU105

with through coolant supply

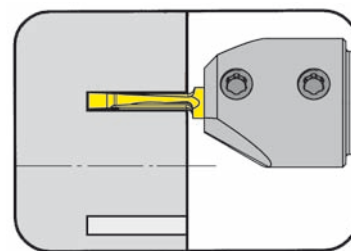

from outer groove Ø	.394"
Depth of groove up to	.591"
Width of groove up to	.118"

Clamping length 22 mm

for use with Insert

Type A105

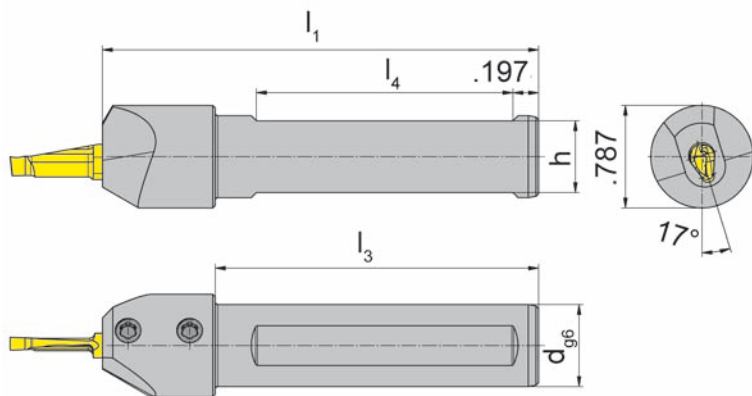

L = left hand version shown

R = right hand version

only usable for inserts with extended clamping length

Part number	d	l ₁	h	l ₃	l ₄
R/LBU105.0625.12.2	.625	3.347	.546	2.480	1.969
R/LBU105.0750.12.2	.750	3.937	.671	-	2.165
R/LBU105.1000.12.2	1.000		.921		

State R or L version

Dimensions in inch

Further sizes upon request

Spare parts

Toolholder	Screw	TORX PLUS® Wrench
R/LBU105....	6.075T15P	T15PQ

A112

TOOLHOLDER Type

B105

with through coolant supply

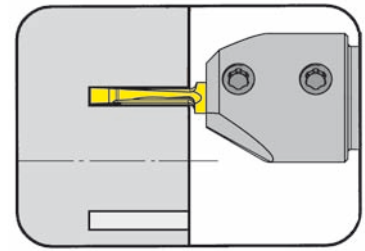

from outer groove Ø	.394" (10.0 mm)
Depth of groove up to	.591" (15.0 mm)
Width of groove up to	.118" (3.0 mm)

Clamping length 22 mm

for use with Insert

Type A105

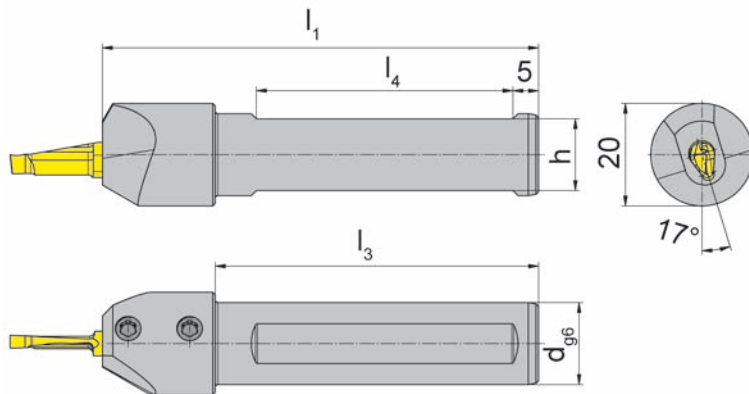

L = left hand version shown

R = right hand version

only usable for inserts with extended clamping length

Part number	d	l ₁	h	l ₃	l ₄
R/LB105.0016.12.2	16	85	14	63	50
R/LB105.0020.12.2	20	100	18	-	55

State R or L version

Dimensions in mm

Further sizes upon request

Spare parts

Toolholder	Screw	TORX PLUS® Wrench
R/LB105.00...	6.075T15P	T15PQ

INSERT Type

A105

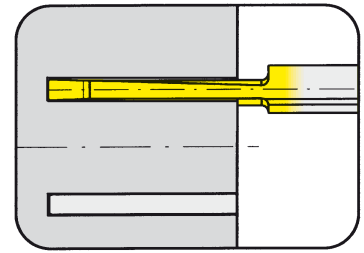

from outer groove Ø	.394"
Depth of groove up to	.591"
Width of groove up to	.118"

for use with Toolholder

Type BU105...12.2
B105...12.2

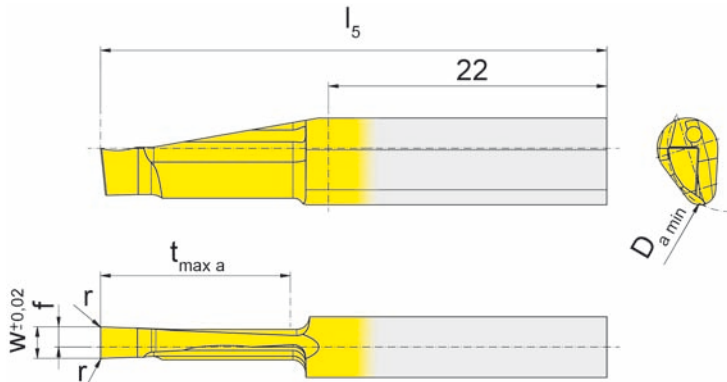

L = left hand version shown

R = right hand version

Part number	w	f	l ₅	t _{max a}	D _{a min}	r	Carbide grades				
							MG12	TN35	TI25	TF45	TH35
R/LA105.1020.2.2	.079	.055							▲▲		
R/LA105.1025.2.2	.098	.063	1.575	.591	.394	.004			▲▲		
R/LA105.1030.2.2	.118	.075							▲/▲		
							P		●		
							M		●		
							K		●		
							S		●		
							N		●		
							H				

- ▲ on stock Δ 4 weeks
- main recommendation
- alternative recommendation
- uncoated grades
- coated grades
- brazed/Cermet

Dimensions in inch

Carbide grades

State R or L version

Note:

Use insert RA105 in toolholder RB105
Use insert LA105 in toolholder LB105

Face grooving with full width of the full depth only possible between D_{amin} .394" - 1.575"!

Groove milling with System 275
from Cutting edge \emptyset

\emptyset 1.221" (31.0 mm)

Example:

Milling cutter M275.0078.A32.14

Cutting edge \emptyset 3.071" (78.0 mm)

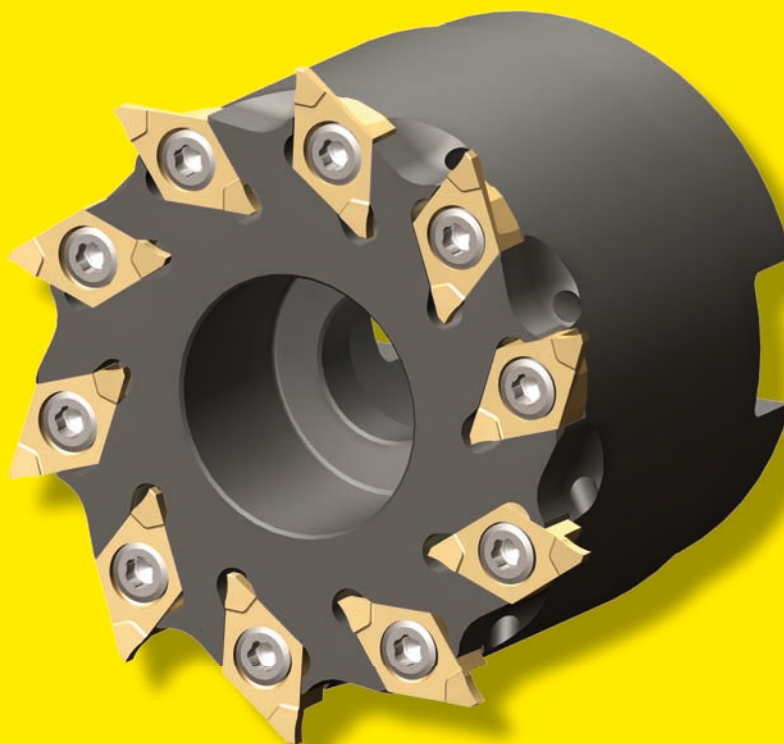

For further information, please see HORN catalog "CARBIDE MILLING TOOLS".

TOOLHOLDER Type

BU105...02

with through coolant supply

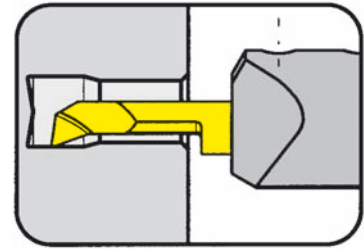

Bore Ø from .197"

for use with Insert

Type 105...2

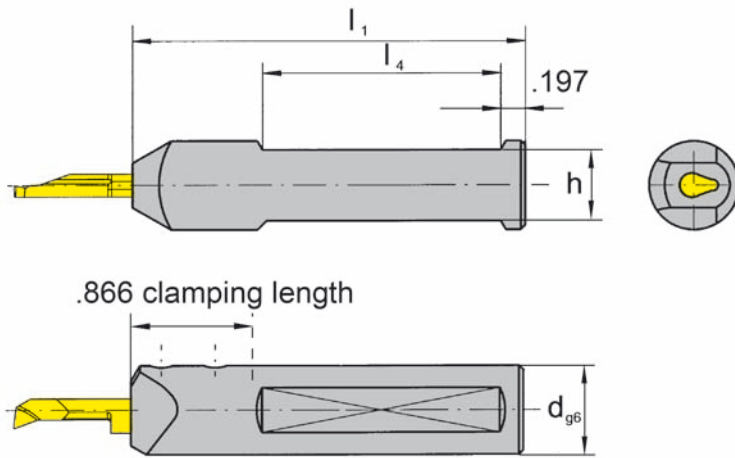

Picture = right hand cutting version shown

only usable for inserts with extended clamping length

Part number	d	l ₁	h	l ₄
BU105.0500.02	.500	3.346	.433	1.969
BU105.0625.02	.625	3.346	.551	1.969
BU105.0750.02	.750	3.937	.709	2.165

Further sizes upon request

Dimensions in inch

Spare parts

Toolholder	Screw	TORX PLUS® Wrench
BU105.0...	6.075T15P	T15PQ

TOOLHOLDER Type

B105...02

with through coolant supply

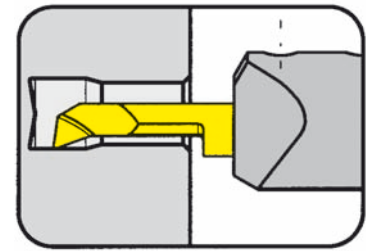

Bore Ø from .472" (12.0 mm)

for use with Insert

Type 105...2

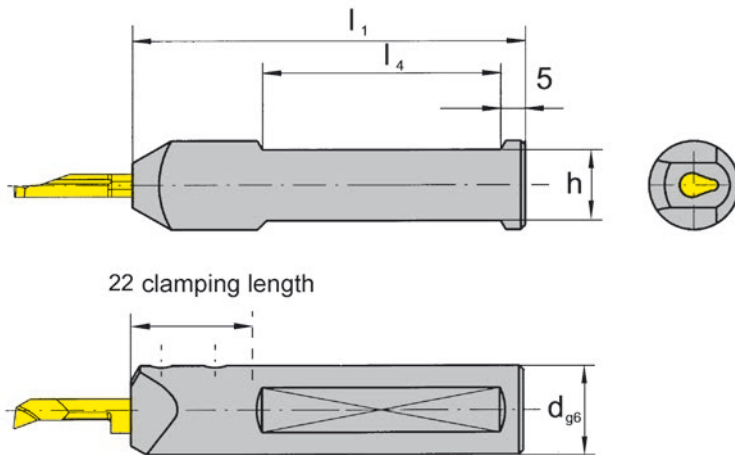

Picture = right hand cutting version shown

only usable for inserts with extended clamping length

Part number	d	l ₁	h	l ₄
B105.0012.02	12	85	11	50
B105.0016.02	16	85	14	50
B105.0020.02	20	100	18	55
B105.0022.02	22	100	20	55

Further sizes upon request

Dimensions in mm

Ordering note:

Toolholders can be used with right and left hand inserts.

Spare parts

Toolholder	Screw	TORX PLUS® Wrench
B105.00...	6.075T15P	T15PQ

TOOLHOLDER Type

B105C

with through coolant supply

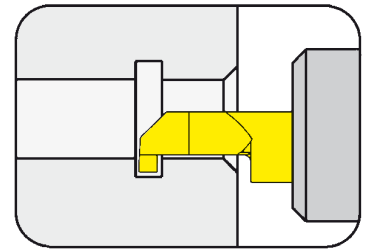

Adapter for inserts type 105 HORN-Capto

Clamping length 22 mm

for use with Insert

Type 105...2

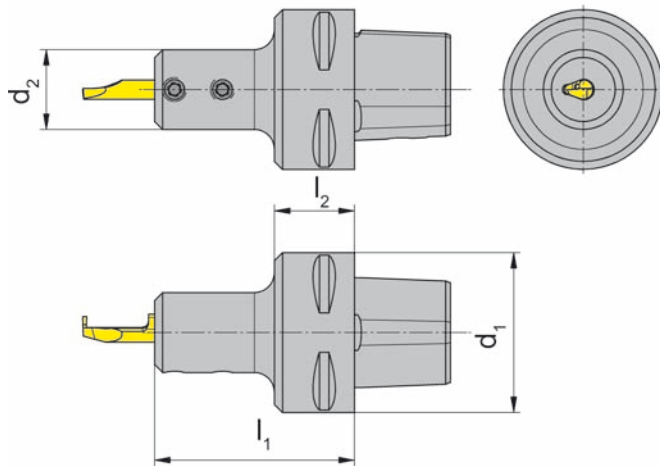

L = left hand version shown

R = right hand version

only usable for inserts with extended clamping length

Part number	l_1	l_2	d_2	d_1	Remark
R/LB105.00C4.20.1.02	50	20	20	40	C4
R/LB105.00C6.20.1.02	52	22	20	63	C6

State R or L version

Dimensions in mm

Further sizes upon request

Spare parts

Toolholder	Screw	TORX PLUS® Wrench
R/LB105.00C...	6.075T15P	T15PQ

A118

INSERT Type

105

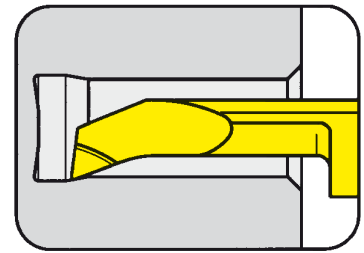

Bore Ø from .197"

Clamping length 22 mm

for use with Toolholder

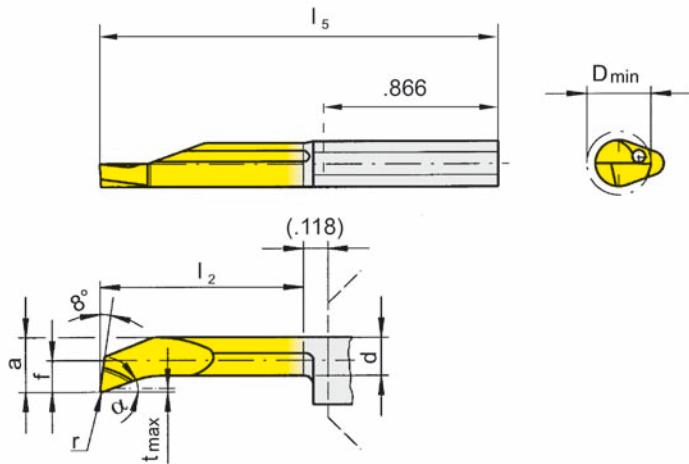

Type BU105...02
B105...02
B105C...02

with extended clamping length

R = right hand version shown

L = left hand version

Part number	f	a	d	l ₂	l ₅	t _{max}	D _{min}	r	α	Carbide grades				
										MG12	TN35	TI25	TF45	TH35
R/L105.1823.4.5.2	.091	.185	.165	.984	1.969	.012	.197	.004	20°			▲▲		▲▲
R/L105.1823.5.5.2				1.181	2.165						▲▲	▲▲		
R/L105.1833.4.6.2	.130	.224	.193	.984	1.969	.012	.236	.004	20°			▲/▲		▲/▲
R/L105.1833.5.6.2				1.181	2.165						▲▲	▲▲		
R/L105.1840.4.7.2	.157	.252	.213	.984	1.969	.012	.268	.004	20°			▲/▲		▲/▲
R/L105.1840.5.7.2				1.181	2.165						▲/▲	▲/▲		
R/L105.1840.7.7.2				1.575	2.559						▲/			
R/L105.4733.5.6.2				.130	.224					.146	1.181	2.165	.071	.236
										P		•		•
										M		•		•
										K		•		•
										S		•		•
										N		•		•
										H				

- ▲ on stock Δ 4 weeks
- main recommendation
- o alternative recommendation
- uncoated grades
- coated grades
- brazed/Cermet

Dimensions in inch

State R or L version

Carbide grades