



PT Series Manual Trolley – Installation and Safety Instructions

JET Manual Trolleys are designed to be used on either "I" or "H" wide flange beams.

JET PT Series Trolleys comply with OSHA regulations, ANSI/ASME B30.11 and B30.17 standards.



IMPORTANT SAFETY INSTRUCTIONS

To reduce risk of injury:

1. Beam must be properly installed and rated for anticipated loads.
2. Do not install trolley on beams of unknown capacity.
3. Do not install trolley on damaged or deformed beams.
4. JET trolleys are designed to be used with hoists of the same rated capacity. Never use a hoist with a capacity greater than the capacity of the trolley.
5. Never subject trolley to a side pull or load. Load must be centered directly under the hoist / trolley assembly.
6. Make sure load is stable and secure before moving.
7. Never lift load more than is necessary to safely move it.
8. Always follow installation instructions.
9. Do not use if under the influence of drugs, alcohol, or medication.

Installation Instructions

(refer to Figure 1)

1. Trolley must be installed on a beam with minimum clearance (wheels to flange) of 1/16" to maximum of 1/8". Reference "Z" on both sides of the beam.
2. To extend trolley width, remove split pins and hex nuts. Remove washers from center bolt and place between hanger plate and fixed spacer. **Note:** Washers **must** be moved in sets of two, one on either side of hanger plate, as hanger plate must always remain centered between trolley side plates.
3. Once trolley width is spaced properly, install remaining washers on center bolt (same number on both sides) on outside of side plates. Install hex nuts and split pins. **Do not over tighten nuts.** Tighten nuts and then back nuts off to align the nut with hole in shaft for split pin. Insert split pin through each hex nut and bend one end of split pin to secure.
4. Re-check wheel clearance "Z" and re-adjust if necessary

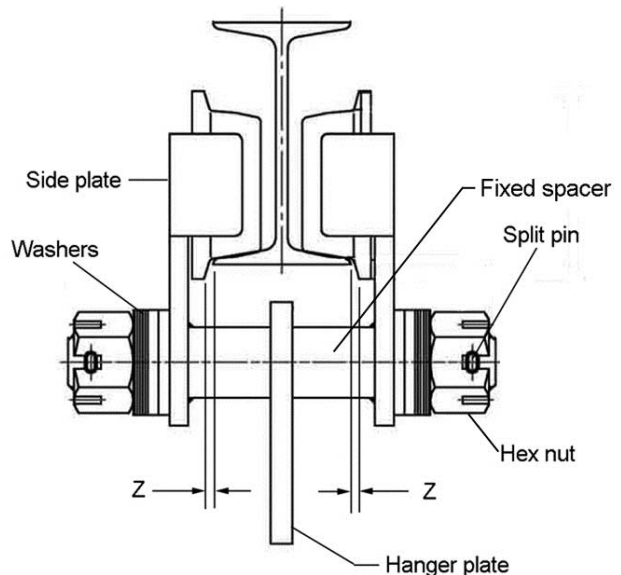

Figure 1

JET

427 New Sanford Road
LaVergne, Tennessee 37086
Ph.: 800-274-6848
www.jettools.com

Part No. M-252005

Revision C 09/2015

Copyright © 2015 JET, a Division of JPW Industries, Inc.

PT Series Trolley: Specifications

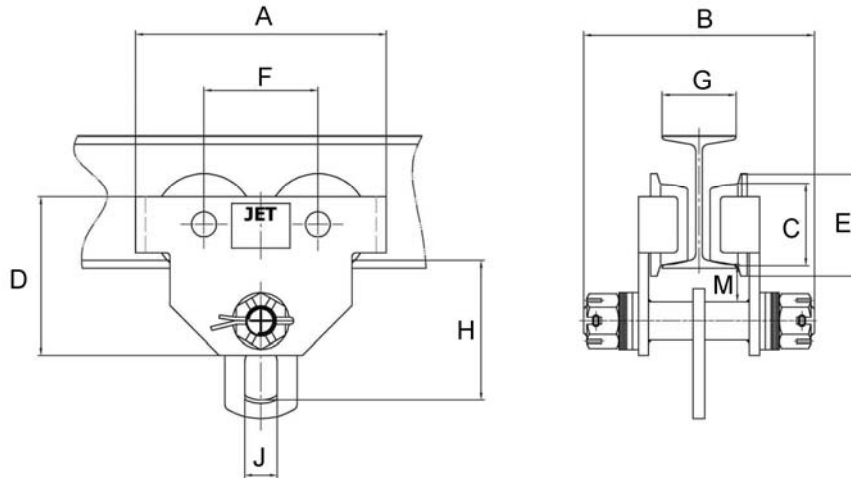

Capacity (Ton)	Stock No.		Beam Flange Width G (min-max)	Beam Height (min-max)	Min. Radius Curve	Shipping Weight	A	B	C (Ø)	D	E (Ø)	F	H	J	M
1/2 Ton	252005	mm	64-203	76-622	900	8.5 (kg)	212	312	58	130	82	102	113	24	37.5
		in.	2-1/2-8	3-24.5	35	19 (lb)	8.35	12.28	2.28	5.12	3.23	4	4.45	0.95	1.5
1 Ton	252010	mm	76-203	127-622	1000	15 (kg)	252	330	75	155	102	118	128	30.5	32.5
		in.	3-8	5-24.5	39	33 (lb)	9.92	13	2.95	6.10	4	4.65	5.04	1.20	1.28
1-1/2 Ton	252015	mm	82-203	153-622	1100	18.5 (kg)	281	336	85	162	115	124	145	33	35.5
		in.	3-1/4-8	6-24.5	43	41 (lb)	11.06	13.23	3.35	6.38	4.53	4.88	5.71	1.3	1.4
2 Ton	252020	mm	82-203	153-622	1100	23 (kg)	302	350	90	170	127	137	152	36	35.75
		in.	3-1/4-8	6-24.5	43	51 (lb)	11.89	13.78	3.54	6.69	5	5.40	5.98	1.42	1.41
3 Ton	252030	mm	102-203	203-622	1300	37.5 (kg)	346	370	110	217	147	157	186	45	50.75
		in.	4-8	8-24.5	51	83 (lb)	13.62	14.57	4.33	8.54	5.79	6.18	7.32	1.77	2
5 Ton	252050	mm	117-203	254-622	1400	54.5 (kg)	382	400	122	255	160	172	219	60	58.75
		in.	4-5/8-8	10-24.5	55	120 (lb)	15.04	15.75	4.80	10.04	6.30	6.77	8.62	2.36	2.3
10 Ton	252060	mm	120-203	254-622	1700	92 (kg)	455	432	151	295	189	200	275	82	75.25
		in.	4-3/4-8	10-24.5	67	202 (lb)	17.91	17	5.94	11.61	7.44	7.87	10.83	3.23	3

Specifications in this document were current at time of publication, but because of our policy of continuous improvement, JET reserves the right to change specifications at any time and without prior notice, without incurring obligations.

PT Series Trolley: Parts Breakdown

Index	Part No.	Description	Qty
1	1/2PT-1	Wheel (1/2 ton)	4
	1PT-1	Wheel (1 ton)	4
	1-1/2PT-1	Wheel (1-1/2 ton)	4
	2PT-1	Wheel (2 ton)	4
	3PT-1	Wheel (3 ton)	4
	5PT-1	Wheel (5 ton)	4
	10PT-1	Wheel (10 ton)	4
2	BB-6203ZZ	Bearing (1/2, 1 ton)	4
	BB-6204ZZ	Bearing (1-1/2 ton)	4
	BB-6205ZZ	Bearing (2 ton)	4
	BB-6206ZZ	Bearing (3 ton)	4
	BB-6207ZZ	Bearing (5 ton)	8
	BB-6210ZZ	Bearing (10 ton)	8
3	F006045	Snap Ring ø17mm (1/2, 1 ton)	4
	F006047	Snap Ring ø20mm (1-1/2 ton)	4
	F006050	Snap Ring ø25mm (2 ton)	4
	F006052	Snap Ring ø30mm (3 ton)	4
	F006054	Snap Ring ø35mm (5 ton)	4
	F006071	Snap Ring ø50mm (10 ton)	4
4	1/2PT-4	Shield (1/2, 1 ton)	4
	2HDT-4	Shield (1-1/2 ton)	4
	2PT-4	Shield (2 ton)	4
	3PT-4	Shield (3 ton)	4
	5HDT-4	Shield (5 ton)	4
	10PT-4	Shield (10 ton)	4
5	F006035	Snap Ring ø40mm (1/2, 1 ton)	4
	F006072	Snap Ring ø47mm (1-1/2 ton)	4
	F006073	Snap Ring ø52mm (2 ton)	4
	F006038	Snap Ring ø60mm (3 ton)	4
	PT5-5	Snap Ring ø72mm (5 ton)	4
	PT10-5	Snap Ring ø90mm (10 ton)	4
6	1/2PT-6	Shaft (1/2 ton)	1
	1PT-6	Shaft (1 ton)	1
	1-1/2PT-6	Shaft (1-1/2 ton)	1
	2PT-6	Shaft (2 ton)	1
	3PT-6	Shaft (3 ton)	1
	5PT-6	Shaft (5 ton)	1
	10PT-6	Shaft (10 ton)	1
7	1/2PT-7	Side Plate (1/2 ton)	2
	1PT-7	Side Plate (1 ton)	2
	1-1/2PT-7	Side Plate (1-1/2 ton)	2
	2PT-7	Side Plate (2 ton)	2
	3PT-7	Side Plate (3 ton)	2
	5PT-7	Side Plate (5 ton)	2
	10PT-7	Side Plate (10 ton)	2
8	1/2GBT-23	Split Pin ø4x50mm (1/2 ton)	2
	1GBT-23	Split Pin ø6x65mm (1 ton)	2
	2GBT-23	Split Pin ø6x75mm (2 ton)	2
	3GBT-23	Split Pin ø6x80mm (3 ton)	2
	5GBT-23	Split Pin ø8x80mm (5 ton)	2
	10GBT-23	Split Pin ø8x90mm (10 ton)	2

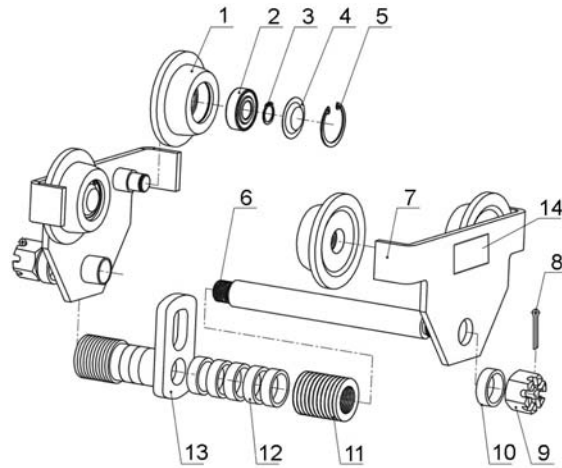

Index	Part No.	Description	Qty
9	1/2GBT-26	Nut M24 (1/2 ton)	2
	1GBT-26	Nut M30 (1, 1-1/2 ton)	2
	2GBT-26	Nut M36 (2 ton)	2
	3GBT-26	Nut M42 (3 ton)	2
	5GBT-26	Nut M42 (5 ton)	2
	10GBT-26	Nut M48 (10 ton)	2
10	5PT-10	Outer Adjusting Washer (5 ton)	2
	10PT-10	Outer Adjusting Washer (10 ton)	2
11	1/2GT-31	Adjusting Washer 8mm (1/2 ton)	18
	1GT-31	Adjusting Washer 8mm (1 ton)	10
	1-1/2PT-11	Adjusting Washer 8mm (1-1/2 ton)	16
	2GT-31	Adjusting Washer 8mm (2 ton)	16
	3GT-31	Adjusting Washer 8mm (3 ton)	16
	5GT-31	Adjusting Washer 8mm (5 ton)	16
	10GT-31	Adjusting Washer 8mm (10 ton)	16
12	1/2GT-32	Adjusting Washer 2mm (1/2 ton)	14
	1GT-32	Adjusting Washer 2mm (1 ton)	14
	1-1/2PT-12	Adjusting Washer 2mm (1-1/2 ton)	12
	2GT-32	Adjusting Washer 2mm (2 ton)	12
	3GT-32	Adjusting Washer 2mm (3 ton)	10
	5GT-32	Adjusting Washer 2mm (5 ton)	8
	10GT-32	Adjusting Washer 2mm (10 ton)	8
13	1/2GBT-29G	Hanger Plate (1/2 ton)	1
	1GBT-29G	Hanger Plate (1 ton)	1
	1-1/2PT-13G	Hanger Plate (1-1/2 ton)	1
	2GBT-29G	Hanger Plate (2 ton)	1
	3GBT-29G	Hanger Plate (3 ton)	1
	5GBT-29G	Hanger Plate (5 ton)	1
14	10GBT-29	Hanger Plate (10 ton)	1
	LM000094	Name Plate 1/2PT	1
	LM000095	Name Plate 1PT	1
	LM000096	Name Plate 1-1/2PT	1
	LM000097	Name Plate 2PT	1
	LM000098	Name Plate 3PT	1
	LM000099	Name Plate 5PT	1
LM000100	Name Plate 10PT	1	

1/2PT-SPK, Spacer Kit for 1/2 ton (includes #11 and 12)

1-1/2PT-SPK, Spacer Kit for 1 1/2 ton (includes #11 and 12)

1PT-SPK, Spacer Kit for 1 ton (includes #11 and 12)

2PT-SPK, Spacer Kit for 2 ton (includes #11 and 12)

3PT-SPK, Spacer Kit for 3 ton (includes #11 and 12)

5PT-SPK, Spacer Kit for 5 ton (includes #11 and 12)

10PT-SPK, Spacer Kit for 10 ton (includes #11 and 12)

Warranty and service

JET warrants every product it sells against manufacturers' defects. If one of our tools needs service or repair, please contact Technical Service by calling 1-800-274-6846, 8AM to 5PM CST, Monday through Friday.

Warranty Period

The general warranty lasts for the time period specified in the literature included with your product or on the official JET branded website.

- JET products carry a limited warranty which varies in duration based upon the product. (See chart below)
- Accessories carry a limited warranty of one year from the date of receipt.
- Consumable items are defined as expendable parts or accessories expected to become inoperable within a reasonable amount of use and are covered by a 90 day limited warranty against manufacturer's defects.

Who is Covered

This warranty covers only the initial purchaser of the product from the date of delivery.

What is Covered

This warranty covers any defects in workmanship or materials subject to the limitations stated below. This warranty does not cover failures due directly or indirectly to misuse, abuse, negligence or accidents, normal wear-and-tear, improper repair, alterations or lack of maintenance. JET woodworking machinery is designed to be used with Wood. Use of these machines in the processing of metal, plastics, or other materials outside recommended guidelines may void the warranty. The exceptions are acrylics and other natural items that are made specifically for wood turning.

Warranty Limitations

Woodworking products with a Five Year Warranty that are used for commercial or industrial purposes default to a Two Year Warranty. Please contact Technical Service at 1-800-274-6846 for further clarification.

How to Get Technical Support

Please contact Technical Service by calling 1-800-274-6846. **Please note that you will be asked to provide proof of initial purchase when calling.** If a product requires further inspection, the Technical Service representative will explain and assist with any additional action needed. JET has Authorized Service Centers located throughout the United States. For the name of an Authorized Service Center in your area call 1-800-274-6846 or use the Service Center Locator on the JET website.

More Information

JET is constantly adding new products. For complete, up-to-date product information, check with your local distributor or visit the JET website.

How State Law Applies

This warranty gives you specific legal rights, subject to applicable state law.

Limitations on This Warranty

JET LIMITS ALL IMPLIED WARRANTIES TO THE PERIOD OF THE LIMITED WARRANTY FOR EACH PRODUCT. EXCEPT AS STATED HEREIN, ANY IMPLIED WARRANTIES OF MERCHANTABILITY AND FITNESS FOR A PARTICULAR PURPOSE ARE EXCLUDED. SOME STATES DO NOT ALLOW LIMITATIONS ON HOW LONG AN IMPLIED WARRANTY LASTS, SO THE ABOVE LIMITATION MAY NOT APPLY TO YOU.

JET SHALL IN NO EVENT BE LIABLE FOR DEATH, INJURIES TO PERSONS OR PROPERTY, OR FOR INCIDENTAL, CONTINGENT, SPECIAL, OR CONSEQUENTIAL DAMAGES ARISING FROM THE USE OF OUR PRODUCTS. SOME STATES DO NOT ALLOW THE EXCLUSION OR LIMITATION OF INCIDENTAL OR CONSEQUENTIAL DAMAGES, SO THE ABOVE LIMITATION OR EXCLUSION MAY NOT APPLY TO YOU.

JET sells through distributors only. The specifications listed in JET printed materials and on official JET website are given as general information and are not binding. JET reserves the right to effect at any time, without prior notice, those alterations to parts, fittings, and accessory equipment which they may deem necessary for any reason whatsoever. JET® branded products are not sold in Canada by JPW Industries, Inc.

Product Listing with Warranty Period

90 Days – Parts; Consumable items
1 Year – Motors; Machine Accessories
2 Year – Metalworking Machinery; Electric Hoists, Electric Hoist Accessories; Woodworking Machinery used for industrial or commercial purposes
5 Year – Woodworking Machinery
Limited Lifetime – JET Parallel clamps; VOLT Series Electric Hoists; Manual Hoists; Manual Hoist Accessories; Shop Tools; Warehouse & Dock products; Hand Tools; Air Tools

NOTE: JET is a division of JPW Industries, Inc. References in this document to JET also apply to JPW Industries, Inc., or any of its successors in interest to the JET brand.