

High Performance End Mills



Milling

HIGH PERFORMANCE END MILLS	SERIES	DESCRIPTION	PAGE
Z-Carb-HPR	Z5	5 Flute Rougher Square End Fractional	28
	Z5CR	5 Flute Rougher Corner Radius Fractional	28
	Z5MCR	5 Flute Rougher Corner Radius Metric	35
Z-Carb-AP	Z1PCR	4 Flute Variable Rake Corner Radius Fractional	39
	Z1PLC	4 Flute Variable Rake Long Reach Corner Radius Fractional	41
	Z1PLB	4 Flute Variable Rake Ball End Long Reach Fractional	42
	Z1MPCR	4 Flute Variable Rake Corner Radius Metric	45
	Z1MPIC	4 Flute Variable Rake Intermediate Reach Corner Radius Metric	46
	Z1MPLC	4 Flute Variable Rake Long Reach Corner Radius Metric	46
	Z-Carb	Z1	4 Flute Variable Geometry Square End Fractional
Z16CR		4 Flute Variable Geometry Corner Radius Fractional	49
Z1B		4 Flute Variable Geometry Ball End Fractional	50
Z1M		4 Flute Variable Geometry Square End Metric	53
Z1MB		4 Flute Variable Geometry Ball End Metric	54
Z-Carb-HTA	ZH1CR	4 Flute Variable Geometry High Temp Alloys Corner Radius Fractional	57
	ZH1MCR	4 Flute Variable Geometry High Temp Alloys Corner Radius Metric	59
	ZH1MCRS	4 Flute Variable Geometry High Temp Alloys Stub Corner Radius Metric	59
Z-Carb-MD	ZD1CR	4 Flute Variable Geometry Hard Materials Long Reach Corner Radius Fractional	61
	ZD1MCR	4 Flute Variable Geometry Hard Materials Long Reach Corner Radius Metric	61
V-Carb	55	5 Flute Finisher & Semi-Finisher Square End Fractional	63
	55CR	5 Flute Finisher & Semi-Finisher Corner Radius Fractional	63
	55M	5 Flute Finisher & Semi-Finisher Square End Metric	65
	55MCR	5 Flute Finisher & Semi-Finisher Corner Radius Metric	65
	55B	5 Flute Finisher & Semi-Finisher Ball End Fractional	68
	55MB	5 Flute Finisher & Semi-Finisher Ball End Metric	68
T-Carb®	51	6 Flute High Speed Machining Square End Fractional	74
	51CR	6 Flute High Speed Machining Corner Radius Fractional	74
	51L	6 Flute High Speed Machining Square End Long Reach Fractional	75
	51LC	6 Flute High Speed Machining Long Reach Corner Radius Fractional	75
	51M	6 Flute High Speed Machining Square End Metric	78
	51MCR	6 Flute High Speed Machining Corner Radius Metric	78
	51ML	6 Flute High Speed Machining Square End Long Reach Metric	79
	51MLC	6 Flute High Speed Machining Long Reach Corner Radius Metric	79

Speed & Feed Recommendations listed after each series

HIGH PERFORMANCE END MILLS	SERIES	DESCRIPTION	PAGE
H-Carb	77	7 Flute High Efficiency Square End Fractional	82
	77CR	7 Flute High Efficiency Corner Radius Fractional	82
	77M	7 Flute High Efficiency Square End Metric	84
	77MCR	7 Flute High Efficiency Corner Radius Metric	84
Multi-Carb	66	Multi-Flute Finisher Square End Fractional	90
	66CR	Multi-Flute Finisher Corner Radius Fractional	90
	66M	Multi-Flute Finisher Square End Metric	93
	66MCR	Multi-Flute Finisher Corner Radius Metric	93
Series 33	33CR	3 Flute Difficult to Machine Materials Corner Radius Fractional	97
	33MCR	3 Flute Difficult to Machine Materials Corner Radius Metric	100
Series 7	7	4 Flute Variable Geometry Long Length Square End Fractional	103
	7M	4 Flute Variable Geometry Long Length Square End Metric	103
	7B	4 Flute Variable Geometry Long Length Ball End Fractional	104
	7MB	4 Flute Variable Geometry Long Length Ball End Metric	104
Turbo-Carb	56B	2 Flute Contouring Long Reach Ball End Fractional	107
	56MB	2 Flute Contouring Long Reach Ball End Metric	107
Power-Carb®	57	6 Flute Finisher Square End Fractional	110
	57M	6 Flute Finisher Square End Metric	110
CFRP Slow Helix	27	4 Flute Slow Helix Square End Fractional	113
	27M	4 Flute Slow Helix Square End Metric	113
Picatinny Rail Tools		3 Flute Non-Ferrous Recoil Groove Tool Groove Fractional	116
		5 Flute Non-Ferrous Dovetail Form Tool Fractional	116
		3 Flute Ferrous Recoil Groove Tool Fractional	117
		5 Flute Ferrous Dovetail Form Tool Fractional	117

Speed & Feed Recommendations listed after each series

FRESAS DE ALTO RENDIMIENTO	SERIE	DESCRIPCIÓN	PÁGINA
Z-Carb-HPR	Z5	5 fillos, desbastador, punta cuadrada, fraccional	28
	Z5CR	5 fillos, desbastador, radio angulado, fraccional	28
	Z5MCR	5 fillos, desbastador, radio angulado, métrico	35
Z-Carb-AP	Z1PCR	4 fillos, inclinación variable, radio angulado, fraccional	39
	Z1PLC	4 fillos, inclinación variable, largo alcance, radio angulado, fraccional	41
	Z1PLB	4 fillos, inclinación variable, punta esférica, largo alcance, fraccional	42
	Z1MPCR	4 fillos, inclinación variable, radio angulado, métrico	45
	Z1MPIC	4 fillos, inclinación variable, medio alcance, radio angulado, métrico	46
	Z1MPLC	4 fillos, inclinación variable, largo alcance, radio angulado, métrico	46
	Z-Carb	Z1	4 fillos, geometría variable, punta cuadrada, fraccional
Z16CR		4 fillos, geometría variable, radio angulado, fraccional	49
Z1B		4 fillos, geometría variable, punta esférica, fraccional	50
Z1M		4 fillos, geometría variable, punta cuadrada, métrico	53
Z1MB		4 fillos, geometría variable, punta esférica, métrico	54
Z-Carb-HTA	ZH1CR	4 fillos, geometría variable, aleaciones termorresistentes, radio angulado, fraccional	57
	ZH1MCR	4 fillos, geometría variable, aleaciones termorresistentes, radio angulado, métrico	59
	ZH1MCRS	4 fillos, geometría variable, aleaciones termorresistentes, versión corta, radio angulado, métrico	59
Z-Carb-MD	ZD1CR	4 fillos, geometría variable, materiales duros, largo alcance, radio angulado, fraccional	61
	ZD1MCR	4 fillos, geometría variable, materiales duros, largo alcance, radio angulado, métrico	61
V-Carb	55	5 fillos, acabador y semiacabador, punta cuadrada, fraccional	63
	55CR	5 fillos, acabador y semiacabador, radio angulado, fraccional	63
	55M	5 fillos, acabador y semiacabador, punta cuadrada, métrico	65
	55MCR	5 fillos, acabador y semiacabador, radio angulado, métrico	65
	55B	5 fillos, acabador y semiacabador, punta esférica, fraccional	68
	55MB	5 fillos, acabador y semiacabador, punta esférica, métrico	68
T-Carb®	51	6 fillos, mecanizado de alta velocidad, punta cuadrada, fraccional	74
	51CR	6 fillos mecanizado de alta velocidad, radio angulado, fraccional	74
	51L	6 fillos, mecanizado de alta velocidad, punta cuadrada, largo alcance, fraccional	75
	51LC	6 fillos mecanizado de alta velocidad, largo alcance, radio angulado, fraccional	75
	51M	6 fillos, mecanizado de alta velocidad, punta cuadrada, métrico	78
	51MCR	6 fillos mecanizado de alta velocidad, radio angulado, métrico	78
	51ML	6 fillos, mecanizado de alta velocidad, punta cuadrada, largo alcance, métrico	79
	51MLC	6 fillos mecanizado de alta velocidad, largo alcance, radio angulado, métrico	79
	H-Carb	77	7 fillos de alta eficiencia, punta cuadrada, fraccional
77CR		7 fillos de alta eficiencia, radio angulado, fraccional	82
77M		7 fillos métrica de alta eficiencia, punta cuadrada, métrico	84
77MCR		7 fillos métrica de alta eficiencia, radio angulado, métrico	84
Multi-Carb		66	Filo múltiple, acabador, punta cuadrada, fraccional
	66CR	Filo múltiple, acabador, radio angulado, fraccional	90
	66M	Filo múltiple, acabador, punta cuadrada, métrico	93
	66MCR	Filo múltiple, acabador, radio angulado, métrico	93
	Serie 33	33CR	3 fillos, materiales difíciles de mecanizar, radio angulado, fraccional
33MCR		3 fillos, materiales difíciles de mecanizar, radio angulado, métrico	100
Serie 7	7	4 fillos, geometría variable, longitud larga, punta cuadrada, fraccional	103
	7M	4 fillos, geometría variable, longitud larga, punta cuadrada, métrico	103
	7B	4 fillos, geometría variable, longitud larga, punta esférica, fraccional	104
	7MB	4 fillos, geometría variable, longitud larga, punta esférica, métrico	104
Turbo-Carb	56B	2 fillos, contorneado, largo alcance, punta esférica, fraccional	107
	56MB	2 fillos, contorneado, largo alcance, punta esférica, métrico	107
Power-Carb®	57	6 fillos, acabador, punta cuadrada, fraccional	110
	57M	6 fillos, acabador, punta cuadrada, métrico	110
Helicoidal de avance lento CFRP	27	4 fillos, helicoidal de avance lento, punta cuadrada, fraccional	113
Herramientas de riel Picatinny	27M	4 fillos, helicoidal de avance lento, punta cuadrada, métrico	113
		Herramienta de ranura de retroceso no ferrosa de 3 fillos fraccional	116
		Herramienta de ranura de retroceso ferrosa de 3 fillos fraccional	116
		Herramienta de cola de milano ferrosa de 5 fillos fraccional	117

Recomendaciones de velocidades y avances mostradas tras cada serie

FRAISES A DETOURER UNIVERSELLES	SÉRIES	DESCRIPTION	PAGE
Z-Carb-HPR	Z5	5 dents non rayonné pour l'ébauche (fractionnel)	28
	Z5CR	5 dents rayonnée pour l'ébauche (fractionnel)	28
	Z5MCR	5 dents rayonnée pour l'ébauche (métrique)	35
Z-Carb-AP	Z1PCR	4 dents pas décalé et hélice variable rayonnés (fractionnel)	39
	Z1PLC	4 dents pas décalé et hélice variable rayonnés (fractionnel)	41
	Z1PLB	4 dents à vague de coupe variable longue portée à bout hémisphérique (fractionnel)	42
	Z1MPCR	4 dents pas décalé et hélice variable rayonnés (métrique)	45
	Z1MPIC	4 dents pas décalé, hélice variable, détalonné, rayonnés (métrique)	46
	Z1MPLC	4 dents pas décalé et hélice variable rayonnés (métrique)	46
	Z-Carb	Z1	4 dents géométrie variable non rayonné (fractionnel)
Z16CR		4 dents géométrie variable rayonné (fractionnel)	49
Z1B		4 dents géométrie variable à bout hémisphérique (fractionnel)	50
Z1M		4 dents géométrie variable non rayonné (métrique)	53
Z1MB		4 dents géométrie variable à bout hémisphérique (métrique)	54
Z-Carb-HTA	ZH1CR	4 dents géométrie variable alliages haute température rayonné (fractionnel)	57
	ZH1MCR	4 dents géométrie variable alliages haute température rayonné (métrique)	59
	ZH1MCRS	4 dents géométrie variable, alliages haute température, longueur de l'outil court, rayonné (métrique)	59
Z-Carb-MD	ZD1CR	4 dents géométrie variable matériaux durs longue portée rayonné (fractionnel)	61
	ZD1MCR	4 dents géométrie variable matériaux durs longue portée rayonné (métrique)	61
V-Carb	55	5 dents en bout de finition et semi-finition plat (fractionnel)	63
	55CR	5 dents en bout finition et semi-finition rayonné (fractionnel)	63
	55M	5 dents en bout de finition et semi-finition plat (métrique)	65
	55MCR	5 dents en bout finition et semi-finition rayonné (métrique)	65
	55B	5 dents en bout de finition et semi-finition hémisphérique (fractionnel)	68
	55MB	5 dents en bout de finition et semi-finition hémisphérique (métrique)	68
T-Carb®	51	6 dents pour usinage grande vitesse non rayonné (fractionnel)	74
	51CR	6 dents pour usinage grande vitesse rayonné (fractionnel)	74
	51L	6 dents pour usinage grande vitesse non rayonné extra longue (fractionnel)	75
	51LC	6 dents pour usinage grande vitesse extra longue rayonné (fractionnel)	75
	51M	6 dents pour usinage grande vitesse non rayonné (métrique)	78
	51MCR	6 dents pour usinage grande vitesse rayonné (métrique)	78
	51ML	6 dents pour usinage grande vitesse non rayonné extra longue (métrique)	79
	51MLC	6 dents pour usinage grande vitesse extra longue rayonné (métrique)	79
H-Carb	77	7 dents hautes performances droite côtes (fractionnel)	82
	77CR	7 dents hautes performances torique côtes (fractionnel)	82
	77M	7 dents hautes performances droite côtes (métrique)	84
	77MCR	7 dents hautes performances torique côtes (métrique)	84
Multi-Carb	66	Multi-dents non rayonné pour finition (fractionnel)	90
	66CR	Multi-dents rayonné pour finition (fractionnel)	90
	66M	Multi-dents non rayonné pour finition (métrique)	93
	66MCR	Multi-dents rayonné pour finition (métrique)	93
Série 33	33CR	3 dents rayonné pour l'ébauche dans tous les matériaux sauf non-ferreux (fractionnel)	97
	33MCR	3 dents rayonné pour l'ébauche dans tous les matériaux sauf non-ferreux (métrique)	100
Série 7	7	4 dents géométrie variable à queue longue non rayonné (fractionnel)	103
	7M	4 dents géométrie variable à queue longue non rayonné (métrique)	103
	7B	4 dents géométrie variable à queue longue à bout hémisphérique (fractionnel)	104
	7MB	4 dents géométrie variable à queue longue à bout hémisphérique (métrique)	104
Turbo-Carb	56B	2 dents contournage longue portée à bout hémisphérique (fractionnel)	107
	56MB	2 dents contournage longue portée à bout hémisphérique (métrique)	107
Power-Carb®	57	6 dents en bout de finition plat (fractionnel)	110
	57M	6 dents en bout de finition plat (métrique)	110
CFRP hélice lente	27	4 dents hélice lente non rayonné (fractionnel)	113
	27M	4 dents hélice lente non rayonné (métrique)	113
Outils de rail Picatinny		Outil de rainure de recul non ferreux à 3 dents (fractionnel)	116
		Outil de forme en queue d'aronde non ferreux à 5 dents (fractionnel)	116
		Outil de rainure de recul ferreux à 3 dents (fractionnel)	117
		Outil en queue d'aronde ferreux à 5 dents (fractionnel)	117

Recommandations de vitesse et avance indiquées après chaque série

HOCHLEISTUNGS-SCHAFTFRÄSER	SERIE	BESCHREIBUNG	SEITE	
Z-Carb-HPR	Z5	Zölliger Schruppfräser mit 5 Schneiden ohne Eckenradien	28	
	Z5CR	Zölliger Schruppfräser mit 5 Schneiden und Eckenradien	28	
	Z5MCR	Schruppfräser mit 5 Schneiden und Eckenradien	35	
Z-Carb-AP	Z1PCR	Zölliger Fräser mit 4 variablen Schneiden und Eckenradien	39	
	Z1PLC	Zölliger Langlochfräser mit 4 variablen Schneiden und Eckenradien	41	
	Z1PLB	Zölliger Radiuschaftfräser mit 4 Schneiden und variablem Spanwinkel	42	
	Z1MPCR	Fräser mit 4 Schneiden und variablen Spanwinkel	45	
	Z1MPIC	Fräser mittlerer Länge mit 4 variablen Schneiden und Eckenradien	46	
	Z1MPLC	Langlochfräser mit 4 variablen Schneiden und Eckenradien	46	
	Z1	Zölliger Schaftfräser mit 4 Schneiden ohne Eckenradien und variabler Form	49	
Z-Carb	Z16CR	Zölliger Fräser mit 4 variablen Schneiden und Eckenradien	49	
	Z1B	Zölliger Radiuschaftfräser mit 4 Schneiden und variabler Form	50	
	Z1M	Schaftfräser mit 4 Schneiden ohne Eckenradien und variabler Form	53	
	Z1MB	Radiuschaftfräser mit 4 Schneiden und variabler Form	54	
	Z1CR	Hochwarmfester zölliger Fräser mit 4 variablen Schneiden und Eckenradien	57	
Z-Carb-HTA	ZH1MCR	Hochwarmfester Fräser mit 4 variablen Schneiden und Eckenradien	59	
	ZH1MCRS	Hochwarmfester Fräser mit 4 variablen Schneiden und Eckenradien	59	
	ZD1CR	Zölliger Langlochfräser mit 4 variablen Schneiden, Eckenradien und Form aus Hartmetall	61	
Z-Carb-MD	ZD1MCR	Langlochfräser mit 4 variablen Schneiden, Eckenradien und Form aus Hartmetall	61	
	55	Zölliger Schlicht- und Halbschlichtfräser mit 5 Schneiden ohne Eckenradien und variabler Form	63	
V-Carb	55CR	Zölliger Schlicht- und Halbschlichtfräser mit 5 Schneiden ohne Eckenradien	63	
	55M	Schlicht- und Halbschlichtfräser mit 5 Schneiden ohne Eckenradien und variabler Form	65	
	55MCR	Schlicht- und Halbschlichtfräser mit 5 Schneiden und Eckenradien	65	
	55B	Schlicht- und Halbschlicht-Radiuschaftfräser mit 5 Schneiden ohne Eckenradien	68	
	55MB	Schlicht- und Halbschlicht-Radiuschaftfräser mit 5 Schneiden und variabler Form	68	
	T-Carb®	51	Zölliger Schaftfräser für die Hochgeschwindigkeitsbearbeitung mit 6 Schneiden ohne Eckenradien	74
		51CR	Zölliger Fräser für die Hochgeschwindigkeitsbearbeitung mit 6 Schneiden und Eckenradien	74
		51L	Zölliger Langloch-Schaftfräser aus Schnellstahl mit 6 Schneiden ohne Eckenradien	75
		51ML	Langloch-Schaftfräser aus Schnellstahl mit 6 Schneiden ohne Eckenradien	75
		51M	Schaftfräser für die Hochgeschwindigkeitsbearbeitung mit 6 Schneiden ohne Eckenradien	78
51MCR		Fräser für die Hochgeschwindigkeitsbearbeitung mit 6 Schneiden und Eckenradien aus Schnellstahl	78	
51LC		Zölliger Langlochfräser für die Hochgeschwindigkeitsbearbeitung mit 6 Schneiden und Eckenradien	79	
51MLC		Langlochfräser für die Hochgeschwindigkeitsbearbeitung mit 6 Schneiden und Eckenradien	79	
H-Carb		77	Zölliger Hocheffizienter mit 7 Schneiden ohne Eckenradien	82
		77CR	Zölliger Hocheffizienter mit 7 Schneiden und Eckenradien	82
	77M	Hocheffizienter mit 7 Schneiden ohne Eckenradien	84	
	77MCR	Hocheffizienter mit 7 Schneiden und Eckenradien	84	
Multi-Carb	66	Zölliger mehrschneidiger Schlichtfräser ohne Eckenradien	90	
	66CR	Zölliger mehrschneidiger Schlichtfräser mit Eckenradien	90	
	66M	mehrschneidiger Schlichtfräser ohne Eckenradien	93	
	66MCR	mehrschneidiger Schlichtfräser mit Eckenradien	93	
Serie 33	33CR	Zölliger Fräser mit 3 Schneiden und Eckenradien für schwerspanbare Werkstoffe	97	
	33MCR	Fräser mit 3 Schneiden und Eckenradien für schwerspanbare Werkstoffe	100	
Serie 7	7	Zölliger Langloch-Schaftfräser mit 4 Schneiden ohne Eckenradien und variabler Form	103	
	7M	Langloch-Schaftfräser mit 4 Schneiden ohne Eckenradien und variabler Form	103	
	7B	Zölliger Langloch-Radiuschaftfräser mit 4 Schneiden und variabler Form	104	
	7MB	Langloch-Radiuschaftfräser mit 4 Schneiden und variabler Form	104	
Turbo-Carb	56B	Zölliger Langloch-Profil-Radiuschaftfräser mit 2 Schneiden	107	
	56MB	Langloch-Profil-Radiuschaftfräser mit 2 Schneiden	107	
Power-Carb®	57	Zölliger Schlichtfräser mit 6 Schneiden ohne Eckenradien	110	
	57M	Schlichtfräser mit 6 Schneiden ohne Eckenradien	110	
CFRP Slow Helix	27	Zölliger Schaftfräser mit 4 steilen Schneiden ohne Eckenradien	113	
	27M	Schaftfräser mit 4 steilen Schneiden ohne Eckenradien	113	
Picatinny Schienenwerkzeuge		3 Flöte Nichteisen-Rückstoßnut Nut Grove Bruchteil	116	
		5 Flöte Nichteisen-Schwalbenschwanzform-Werkzeug Bruchteil	116	
		3 Rillen-Eisenrückstoß-Nutwerkzeug fraktioniert	117	
		5 Flöte Eisen Schwalbenschwanz Werkzeug gebrochen	117	

Empfehlungen für Drehzahl & Vorschub im Anhang zu jeder Serie

End Mill Matrix

SGS End Mill Matrix							Preferred Cut Type for Series					Toolpath Preference* 1st 2nd	Flute Count			
Name	Series	Page	Material				• Good	•• Better	••• Best	Not Recommended						
			Steel	Stainless Steel	Cast Iron	High Temp Alloy	Titanium Alloy	Hardened Steel	Non Ferrous	Non Ferrous	Heavy	Moderate	Light	Fine	Finish	
Series 33	33	97	●	●	●	●	●	●	●	●	●	●	●	●	Standard HEM	3
Z-Carb	Z1	49	●	●	●	●	●	●	●	●	●	●	●	●	Standard HEM	4
Z-Carb-AP	Z1P	39	●	●	●	●	●	●	●	●	●	●	●	●	Standard HEM	4
Z-Carb-HTA	ZH1	57	●	●	●	●	●	●	●	●	●	●	●	●	Standard HEM	4
Series 7	7	103	●	●	●	●	●	●	●	●	●	●	●	●	HEM Standard	4
Z-Carb HPR	Z5	28	●	●	●	●	●	●	●	●	●	●	●	●	HEM Standard	5
V-Carb	55	63	●	●	●	●	●	●	●	●	●	●	●	●	HEM Standard	5
T-Carb®	51	74	●	●	●	●	●	●	●	●	●	●	●	●	HEM Standard	6
H-Carb	77	82	●	●	●	●	●	●	●	●	●	●	●	●	HEM Standard	7
Multi Carb	66	90	●	●	●	●	●	●	●	●	●	●	●	●	HEM Standard	7, 9, 11
Turbo Carb	56B	107	●	●	●	●	●	●	●	●	●	●	●	●	HEM Standard	2
Z-Carb-MD	ZD1	61	●	●	●	●	●	●	●	●	●	●	●	●	Standard HEM	4
Power-Carb®	57	110	●	●	●	●	●	●	●	●	●	●	●	●	HEM Standard	6
Ski-Carb	44	163	●	●	●	●	●	●	●	●	●	●	●	●	Standard HEM	2
S-Carb® 2 Flute	47	157	●	●	●	●	●	●	●	●	●	●	●	●	Standard HEM	2
S-Carb® 3 Flute	43	136	●	●	●	●	●	●	●	●	●	●	●	●	Standard HEM	3
S-Carb® Chipbreaker	43CB	146	●	●	●	●	●	●	●	●	●	●	●	NR	Standard HEM	3
S-Carb® APR-3®	43APR-3	127	●	●	●	●	●	●	●	●	●	●	●	NR	Standard HEM	3
S-Carb APR-4®	43APR-4	130	●	●	●	●	●	●	●	●	●	●	●	NR	Standard HEM	4
S-Carb APF®	43APF	132	●	●	●	●	●	●	●	●	●	●	●	●	Standard HEM	4
Slow Helix	27	113	●	●	●	●	●	●	●	●	●	●	●	●	Standard HEM	4
CCR	20-CCR	338	●	●	●	●	●	●	●	●	●	●	●	NR	Standard HEM	5, 8, 10, 12
CCR	31-CCR	342	●	●	●	●	●	●	●	●	●	●	●	NR	Standard HEM	5, 7, 8, 10
Compression Router	25	345	●	●	●	●	●	●	●	●	●	●	●	●	Standard HEM	4, 6, 8
Up Cut Router	21	348	●	●	●	●	●	●	●	●	●	●	●	●	Standard HEM	2
Down Cut Router	22	349	●	●	●	●	●	●	●	●	●	●	●	●	Standard HEM	2

Preferred materials for each Series are highlighted above

Cut depths (Ae & Ap) are based on a percentage of the cutter diameter (DC)

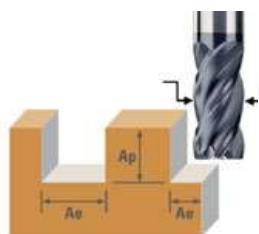

Material	Heavy 100%~40% Ae ≤ 100% Ap	Moderate 100%~40% Ae ≤ 150% Ap	Light 25%~10% Ae ≤ 250% Ap	Fine 10%~2% Ae ≤ 450% Ap	Finish 2%~0% Ae any Ap
Steel P0 to P6	●	●	●	●	●
Stainless Steel M1 to M3	●	●	●	●	●
Cast Iron K1 to K3	●	●	●	●	●
High Temp Alloy S1 to S3	●	●	●	●	●
Titanium Alloy S4	●	●	●	●	●
Hardened Steel H1 to H4	●	●	●	●	●
Non Ferrous N1 to N4	●	●	●	●	●
Non Ferrous N5 to N7	●	●	●	●	●

● Coolant required in these materials
 ○ Plunging not recommended in these materials

Material hardness and machinability affect speed, feed, and cut depths

Long flute or long reach tools require reduced rates and cut depth

Unless marked "NR", a high quality finish can be achieved with any Series tool with adjustments to speed and feed

End Mill Matrix

Cut Diameter Range inch mm	Cut Length Availability (x DC)**	Reach Option (x DC)**	End Styles Square Radius Ball	Chipbreaker Option	Shank Option Solid Round, Weldon Flat, Jet Stream, Coolant Hole	Center Cutting	Maximum Recommended Ramp Angle ***	Helix Angle	Flute Index	Coating
0.125 to 1 3 to 20	2.25 to 3	–	R	By Request	SR, WF	Yes	90	32 / 48	Unequal	Ti-Namite-A
0.125 to 1 3 to 25	1.25 to 3	–	R, B	By Request	SR, WF, JS	Yes	90	35 / 38	Unequal	Ti-Namite-A
0.0156 to 1 1 to 25	1 to 3.25	2.5 to 8.5	S, R, B	By Request	SR, WF, JS	Yes	90	35 / 38	Unequal	Ti-Namite-X
0.250 to 1 6 to 20	1.25 to 3	–	R	By Request	SR, WF	Yes	20	38 / 41	Unequal	Ti-Namite-A
0.125 to 1 3 to 25	2.25 to 8.25	–	S, B	By Request	SR	Yes	1	38	Unequal	Ti-Namite-A
0.125 - 1 6 - 25	1 to 3	–	S, R	By Request	SR, WF, CH	No	7	37	Unequal	Ti-Namite-M Ti-Namite-A
0.125 - 1 6 - 20	1.25 to 5	–	S, R, B	By Request	SR, WF	Yes	5	45	Unequal	Ti-Namite-A
0.250 to 1 6 to 20	1.25 to 3	3.25 to 5.5	S, R	By Request	SR	Yes	3	41	Unequal	Ti-Namite-X
0.250 to 1 6 to 25	2.5 to 4	–	S, R	In Stock Available	SR	No	1	37	Unequal	Ti-Namite-M Ti-Namite-A
0.188 to 1 6 to 25	1.5 to 3.25	–	S, R	By Request	SR	No	1	35	Equal	Ti-Namite-A
0.031 to 0.750 1 to 20	1	2 to 2.25	B	By Request	SR	Yes	25	30	Equal	Ti-Namite-A
0.118 to 0.750 5 to 20	1 to 1.25	2.25 to 5	R	By Request	SR	Yes	2	42 / 45	Unequal	Ti-Namite-A
0.250 to 0.500 6 to 20	2 to 2.25	–	S	By Request	SR	Yes	1	45	Equal	Ti-Namite-A
0.250 to 1 3 to 20	1.25 to 7	–	S, R	By Request	SR, WF	Yes	90	45	Equal	Ti-Namite-B
0.125 to 1 3 to 25	1 to 3	3 to 9	S, B	By Request	SR	Yes	90	35	Equal	Ti-Namite-B
0.125 to 1 3 to 25	1 to 7	2.25 to 8.5	S, R, B	By Request	SR	Yes	90	38	Equal	Ti-Namite-B
0.250 to 1 6 to 20	1 to 7	2.5 to 8.5	R	Standard	SR	Yes	90	38	Equal	Ti-Namite-B
0.750 to 1 12 to 26	1.25 to 1.75	3 to 4	S, R	Standard	CH	Yes	90	38	Unequal	Ti-Namite-B
20 to 25	1.25 to 1.75	2.25 to 3.5	S, R	Standard	CH	Yes	90	38 / 41	Unequal	Ti-Namite-B
0.500 to 0.750 6 to 25	2.5 to 4	3 to 5	S, R	By Request	CH	Yes	25	38 / 41	Unequal	Ti-Namite-B
0.250 to 0.750 6 to 16	1.75 to 4	–	S	By Request	SR	Yes	5	10, 12	Unequal	Di-Namite (optional)
0.250 to 0.500 2 to 12	2.75 to 4	–	S	Standard	SR	Based upon end style	5 (for end cut styles)	15	Equal	Di-Namite (optional)
0.250 to 0.500 6 to 12	2.75 to 4	–	S	Standard	SR	Based upon end style	5 (for end cut styles)	15	Equal	Di-Namite (optional)
0.250 to 0.500 6 to 12	2.75 to 4	–	S	By Request	SR	Yes	5	30	Equal	Di-Namite (optional)
0.125 to 0.750 3 to 12	2.5 to 4.25	–	S	By Request	SR	Yes	90	35	Equal	various optional
0.125 to 0.750 3 to 12	2.5 to 4.25	–	S	By Request	SR	Yes	–	35	Equal	various optional



Standard Toolpath



HEM Toolpath

* HEM toolpaths are usually preferred in most situations. However, standard paths may be more efficient with moderate to heavy cut types

** some variations of Cut Length and Reach are based upon Cut Diameter

*** shown is general recommendation for most materials, lower ramp angles are required for materials with lower machinability

For complete application recommendations refer to the SGS Tool Wizard®



Application Tips

Tool	<ul style="list-style-type: none"> • Whenever possible, select an end mill with the largest diameter, shortest flute length, and shortest overall length for the best rigidity • Long flute tools are not intended for pocketing, slotting, or heavy profiling – limit Ae to .02D • High Performance tools minimize cycle time and extend tool life
Tool Holders	<ul style="list-style-type: none"> • Holders with adequate gripping pressure and TIR are required • Stub holders or zero length collet style holders are recommended for heavy stock removal • When using solid holders, hand ground screw flats are not recommended
Workpiece	<ul style="list-style-type: none"> • Secure clamping of the workpiece will reduce chatter and deflection
Machine	<ul style="list-style-type: none"> • Spindle must be in optimum condition for precise TIR and maximum tool life • Sufficient horsepower is required to perform at recommended speeds and feeds • Reduce rates for low power machines to prevent workpiece and / or tool damage
Coolant	<ul style="list-style-type: none"> • Avoid re-milling chips through use of air blast or liquid coolant as necessary • Maintain clean coolant with appropriate concentration • General recommendations: <ul style="list-style-type: none"> —Water Soluble Oil or Air Blast: Tool Steels, Mold & Die Steels, Carbon or Alloy Steels —Water Soluble Oil: Stainless Steels, Titanium, High Temperature Alloys, Non-Ferrous Alloys
Methods	<ul style="list-style-type: none"> • Climb milling is generally preferred • Attention to programming details, tool holders, TIR, balance, fixturing, etc. improve cutting tool performance and extend tool life

END MILLING GUIDELINE

DC = cutting diameter APMX = flute length

Speeds and Feeds for Cut Types are based on Radial Width (A_e) and Axial Depth (A_p)

Reductions to Speeds and Feeds may be necessary when:

- Ae and Ap exceed recommendations
- Using long flute or extended reach tools
- Using long tool holders
- Machining materials harder than listed

ENTRY METHODS

Pre-Drilled Hole



Pre-drilling is the preferred entry method for most applications.

Helical Ramp



Straight Ramp

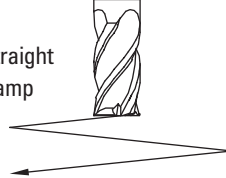

Alternative methods are helical and straight ramping. High ramp angles require reduced feed. Lower ramp angles will allow higher feed rates and extend tool life. Use slotting speeds and feeds for ramp angles of 1° to 2°. Reduce feed to 25% when ramp angles approach 6°. General purpose tools and/or difficult to machine materials will require lower ramp angles and reduced feed.

Plunge



Plunge only in non-ferrous and short-chipping materials using slotting speeds and 25% slotting feeds.

Herramientas	<ul style="list-style-type: none"> • Siempre que sea posible, seleccione la herramienta de mayor diámetro y menor longitud total y de filo para obtener una mayor rigidez. • Las herramientas con filos largos no son recomendadas para operaciones de apertura de cajas en el maquinado, operación de ranurado o perfilado pesado – limitar la profundidad radial (Ae) a .02D • Las herramientas de alto desempeño minimizan el tiempo de ciclo del maquinado y extienden la vida útil de la herramienta
Portaherramientas	<ul style="list-style-type: none"> • Los Portaherramientas deberán tener buena presión de amarre para la sujeción de la herramienta y una concentricidad máxima indicada (TIR) • Se recomienda usar portaherramientas de amarre directo cortos, o de boquilla con longitud cero para lograr un máximo arranque de viruta • Cuando se utilicen portaherramientas de amarre directo, no se recomienda hacer manualmente el plano para la sujeción del tornillo en el zanco de la herramienta
Pieza a maquinar	<ul style="list-style-type: none"> • La buena sujeción de la pieza a maquinar reducirá la vibración y la desviación de la herramienta
Máquina	<ul style="list-style-type: none"> • El husillo de la máquina debe estar en condiciones óptimas, para asegurar la concentricidad de giro (TIR) y asegurar el máximo rendimiento de la herramienta • Para lograr los avances y velocidades recomendados, se necesita suficiente potencia (HP) en la máquina • Reducir los parámetros de corte en máquinas de baja potencia (HP) para prevenir el daño en la herramienta o pieza de trabajo
Refrigeración	<ul style="list-style-type: none"> • Evite el re-maquinado de virutas usando aire a presión o líquido refrigeración según sea necesario • Mantener limpio la refrigeración con su concentración adecuada • Recomendaciones generales: <ul style="list-style-type: none"> –Para el maquinado de aceros de herramienta, para Moldes y Dados o Aleaciones de Bajo Carbón, utilice Aceite Soluble en Agua o aire a presión –Para el maquinado de Aleaciones Inoxidables, Aleaciones Termorresistentes, Titanio y Aleaciones No Ferrosas, utilice solamente Aceite Soluble en Agua
Métodos	<ul style="list-style-type: none"> • Se recomienda el maquinado en sentido ascendente o trepado • El cuidado en los detalles de la programación, la concentricidad de giro (TIR) el balance de los portaherramientas, la sujeción de la pieza a maquinar, etc. son factores que contribuyen a prolongar la vida de la herramienta

GUÍAS DE FRESADO

DC = diámetro de corte APMX = largo de filo

Las velocidades y avances para cortes están basados en la profundidad radial (A_e), y profundidad axial (A_p)

Reducciones en velocidades y avances serán necesarias cuando:

- A_e y A_p exceda las recomendaciones
- Se utilicen filos largos o herramientas de largo alcance
- Se utilicen portaherramientas largos
- Se maquinen materiales más duros que los recomendados

MÉTODOS DE ENTRADA

Barreno previo



Preferentemente usar un barreno previo como método de entrada para la mayor parte de las aplicaciones.

Rampa helicoidal



Rampa recta



Los métodos alternativos son las rampas helicoidales y rectas. Un ángulo elevado de rampa necesita un avance reducido. Un ángulo de rampa inferior permitirá tasas de avance más elevadas y una mayor duración de la herramienta. Usar velocidades y alcances de ranurado para ángulos de rampa de 1° a 2°. Disminuir el avance un 25% cuando los ángulos de rampa se aproximan a 6°. Las herramientas de uso general y/o materiales difíciles de mecanizar precisarán ángulos de rampa inferiores y un avance reducido.

Agujero o Barrenado



Este método se puede utilizar únicamente en materiales no ferrosos y materiales de formación de virutas cortas, usando la velocidad de ranurado y el 25% de su avance.

Conseils relatifs à l'application

Outil	<ul style="list-style-type: none"> • Chaque fois que possible, choisissez une fraise de plus grand diamètre possible, la plus courte possible, elle garantira la meilleure rigidité • Les outils longs ne sont pas optimum pour l'ébauche, le pocketing, le rainurage – Ae limité à 0,02 D • Les outils Haute performance optimisent les temps de cycle et de augmentent la durée de vie
Porte-outils	<ul style="list-style-type: none"> • Des attachements à serrage puissant et à faux rond précis sont recommandés • Attachements à méplats ou pinces à serrage nominale sont recommandées pour les ébauches • Lorsque vous utilisez des attachement rigides, les serrage de l'outil par vis ne sont pas recommandés
Pièce	<ul style="list-style-type: none"> • Le système de fixation et de bridage de la pièce devra permettre de réduire les vibrations et la déformation
Machine	<ul style="list-style-type: none"> • Broche doit être en bon état optimal au niveau de son faux rond • Suffisamment puissance est nécessaire pour effectuer à des vitesses recommandées et se nourrit • Réduire les efforts pour les machines de faible puissance pour éviter l'endommagement de la pièce et / ou de l'outil
Liquide de refroidissement	<ul style="list-style-type: none"> • Évitez le recyclage de copeaux par l'utilisation de soufflage d'air comprimé ou de liquide de refroidissement. • Maintenir le lubrifiant propre à la concentration appropriée • Recommandations générales – <ul style="list-style-type: none"> –Huile soluble ou Air comprimé: aciers à outils, aciers pour moules, aciers au carbone ou alliés –Huile soluble: aciers inoxydables, titane, alliages à haute température, alliages non ferreux
Méthodes	<ul style="list-style-type: none"> • L'usinage en avalant est généralement préconisé • Attention à la programmation, porte-outils, faux rond, équilibrage, fixation, etc améliorent les performances de l'outil en coupe et prolonge la durée de vie

GUIDE DU FRAISAGE

DC = diamètre de coupe APMX = longueur de coupe

Vitesses & avances pour ces cas d'usinage sont basées sur l'engagement radial (A_e), et axial (A_p)

La réduction de la vitesse et de l'avance doit être nécessaire quand:

- Les engagements A_e et A_p sont importants
- Des dentures longues ou des séries longues sont utilisées
- Des attachement longs sont utilisés
- Lors d'usinage de matériaux durs

TYPES D'ENTREE MATIERE

Preperçage



Le préperçage est la méthode préférable dans la plupart de applications.

Ramping
hélicoïdal



Ramping
droit

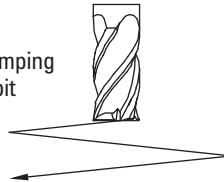

Les autres méthodes sont un ramping hélicoïdal et un ramping droit. Les angles de ramping élevés exigent une avance inférieure. Les angles de ramping inférieurs permettent les taux d'avance supérieurs et prolongeront la vie de l'outil. Utilisez des avances et vitesses de mortaisage pour les angles de ramping de 1° à 2°. Réduisez l'avance à 25 % lorsque les angles de ramping avoisinent 6°. Les outils tout usage et/ou les matériaux difficiles à usiner exigeront des angles de ramping inférieurs et une charge réduite.

Plongée



Plongée uniquement dans les non ferreux. Vitesse rainurage et avances réduites de 25%.

Werkzeug	<ul style="list-style-type: none"> • Wählen Sie möglichst immer den Schafffräser mit dem größten Durchmesser, der kürzesten Schneide und Gesamtlänge, um eine hohe Steifigkeit zu erhalten • Langlochschaftfräser sind nicht zum Taschen-, Schlitz- oder Profilfräsen bestimmt – die Dehnung auf Ae 0,2 der Streckgrenze nicht überschreiten • Hochleistungswerkzeuge minimieren die Bearbeitungszeit und verlängern die Werkzeugstandzeit
Werkzeughalter	<ul style="list-style-type: none"> • Es werden Spannzangen mit genauem Rundlauf benötigt • Steilkegel oder bündige Spannfutter werden bei hohem Materialabtrag empfohlen • Von der Verwendung fester handverschraubter Halterungen wird abgeraten
Werkstück	<ul style="list-style-type: none"> • Sicheres Werkzeugspannen verringert Vibrationen und das Auswandern aus der Spannvorrichtung
Werkzeugmaschine	<ul style="list-style-type: none"> • Die Spindel muss in optimalem Zustand sein, um einen genauen Rundlauf und maximale Standzeit zu erzielen • Für die empfohlenen Drehzahlen und Vorschubgeschwindigkeiten ist genügend Leistung bereitzustellen • Bei leistungsschwachen Antrieben sind die Werte zu verringern, um Beschädigungen am Werkstück und/oder Werkzeug zu vermeiden
Kühlmittel	<ul style="list-style-type: none"> • Das Stauen der Späne durch Luftstrahl oder flüssige Kühlmittel möglichst verhindern • Kühlmittel in geeigneter Konzentration verwenden • Allgemeine Empfehlungen: <ul style="list-style-type: none"> – Wasser-Öl-Emulsionen oder Luftstrahl: Werkzeugstähle, Form- und Schneidstähle, unlegierte oder legierte Stähle – Wasser-Öl-Emulsion: Nichtrostender Stahl, Titan, Warmfeste Legierungen, Nichteisenlegierungen
Verfahren	<ul style="list-style-type: none"> • Vorzugsweise Gleichlaufräsen anwenden • Das Beachten der Fräsparameter, Werkzeughalter, Rundlauf, Auswuchten, Einspannen, usw. verbessert die Schnittleistung und verlängert die Standzeit

RICHTWERTE ZUM FRÄSEN

DC = Fräsdurchmesser APMX = Schnittlänge

Drehzahl und Vorschub für Fräsarbeiten hängen von Radialbreite (A_e) und Frästiefe (A_p) ab

Drehzahl und Vorschub müssen ggfs. verringert werden wenn:

- die empfohlenen Werte für Ae und Ap überschritten werden
- lange Schneiden oder Langschaftfräser verwendet werden
- lange Werkzeughalter verwendet werden
- die Werkstoffe härter als vorgesehen sind

VORBEREITUNGEN

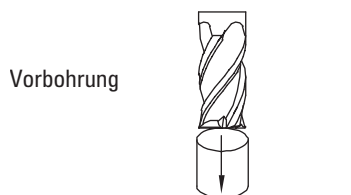

Vorbohren ist in den meisten Fällen ratsam.



Alternative Verfahren sind Zirkulareintauchen und Schrägeintauchen. Starke Tauchwinkel erfordern verringerte Vorschubgeschwindigkeiten. Geringe Tauchwinkel ermöglichen höhere Vorschubgeschwindigkeiten und verlängern die Standzeit. Verwenden Sie die Drehzahlen und Vorschübe zum Schlitzfräsen für Tauchwinkel von 1° bis 2°. Den Vorschub auf 25 % verringern, wenn der Tauchwinkel 6° erreicht. Standardwerkzeuge und / oder schwer zu bearbeitende Werkstoffe verlangen kleine Tauchwinkel und verringerte Vorschubgeschwindigkeiten.

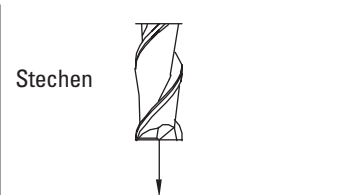

Stechen Sie in Nichteisenmetalle und kurzspanende Werkstoffe nur mit Schlitzfräsdrehzahl und 25 % der Schlitzvorschubgeschwindigkeit ein.

FRACTIONAL Z-Carb-HPR

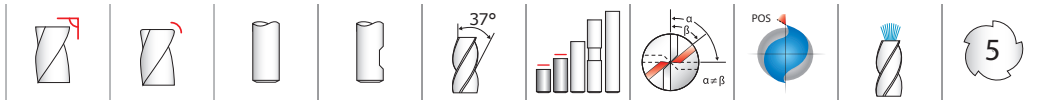

Z5 • Z5CR FRACTIONAL SERIES

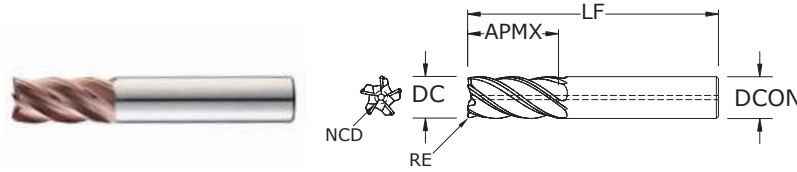

TOLERANCES (inch)

1/8–1/4 DIAMETER
DC = +0.0000/–0.0012
DCON = h_6
RE = +0.0000/–0.0020
>1/4–3/8 DIAMETER
DC = +0.0000/–0.0016
DCON = h_6
RE = +0.0000/–0.0020
>3/8–1 DIAMETER
DC = +0.0000/–0.0020
DCON = h_6
RE = +0.0000/–0.0020

- An ideal balance of helix, indexing, flute depth, rake and relief
- Variable indexing for chatter suppression and patented edge geometry for shearing and strength
- Chatter-free geometry allows deep cutting and high speed machining
- Central coolant hole delivers coolant effectively to the cutting zone enhancing chip removal when pocketing or slotting
- Excels at roughing, ramping, high speed machining and finishing in a variety of materials
- Enhanced corner geometry with tight tolerance corner radii
- Recommended for materials ≤ 45 HRc (≤ 420 Bhn)

- STEELS
- STAINLESS STEELS
- CAST IRON
- HIGH TEMP ALLOYS
- TITANIUM
- HARDENED STEELS

For patent information visit www.ksptpatents.com

inch						EDP NO.					
CUTTING DIAMETER DC	LENGTH OF CUT APMX	OVERALL LENGTH LF	SHANK DIAMETER DCON	CORNER RADIUS RE	NON-CUTTING CENTER DIAMETER NCD	TI-NAMITE-A (TA)	TI-NAMITE-A (TA) W/FLAT	TI-NAMITE-A (TA) W/INTERNAL COOLANT	TI-NAMITE-M (TM)	TI-NAMITE-M (TM) W/FLAT	TI-NAMITE-M (TM) W/INTERNAL COOLANT
1/8	1/4	1-1/2	1/8	–	0.0440	38500	–	–	37000	–	–
1/8	1/4	1-1/2	1/8	0.010	0.0440	38771	–	–	38770	–	–
1/8	1/4	1-1/2	1/8	0.015	0.0440	38525	–	–	37001	–	–
1/8	1/4	1-1/2	1/8	0.030	0.0440	38773	–	–	38772	–	–
1/8	3/8	1-1/2	1/8	–	0.0440	37180	–	–	37002	–	–
1/8	3/8	1-1/2	1/8	0.010	0.0440	38775	–	–	38774	–	–
1/8	3/8	1-1/2	1/8	0.015	0.0290	37181	–	–	37003	–	–
1/8	3/8	1-1/2	1/8	0.030	0.0290	38777	–	–	38776	–	–
3/16	5/16	2	3/16	–	0.0660	38501	–	–	37004	–	–
3/16	5/16	2	3/16	0.010	0.0660	38779	–	–	38778	–	–
3/16	5/16	2	3/16	0.015	0.0660	38526	–	–	37005	–	–
3/16	5/16	2	3/16	0.030	0.0660	38781	–	–	38780	–	–
3/16	1/2	2	3/16	–	0.0660	37182	–	–	37006	–	–
3/16	1/2	2	3/16	0.010	0.0660	38783	–	–	38782	–	–
3/16	1/2	2	3/16	0.015	0.0660	37183	–	–	37007	–	–
3/16	1/2	2	3/16	0.030	0.0660	38785	–	–	38784	–	–
1/4	3/8	2-1/2	1/4	–	0.0880	38502	–	–	37008	–	–
1/4	3/8	2-1/2	1/4	0.010	0.0880	38787	–	–	38786	–	–
1/4	3/8	2-1/2	1/4	0.015	0.0880	38527	–	–	37009	–	–
1/4	3/8	2-1/2	1/4	0.030	0.0880	38528	–	–	37010	–	–
1/4	3/8	2-1/2	1/4	0.060	0.0750	38789	–	–	38788	–	–
1/4	3/8	2-1/2	1/4	0.090	0.0880	38791	–	–	38790	–	–
1/4	1/2	2-1/2	1/4	–	0.0880	37184	–	–	37011	–	–
1/4	1/2	2-1/2	1/4	0.010	0.0880	38793	–	–	38792	–	–
1/4	1/2	2-1/2	1/4	0.015	0.0880	37185	–	–	37012	–	–
1/4	1/2	2-1/2	1/4	0.030	0.0880	37186	–	–	37013	–	–
1/4	1/2	2-1/2	1/4	0.060	0.0750	38795	–	–	38794	–	–
1/4	1/2	2-1/2	1/4	0.090	0.0880	38797	–	–	38796	–	–

continued on next page

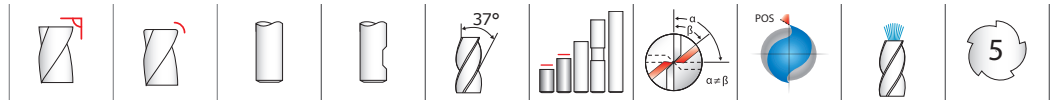

TOLERANCES (inch)

1/8-1/4 DIAMETER

DC = +0.0000/-0.0012

DCON = h₆

RE = +0.0000/-0.0020

>1/4-3/8 DIAMETER

DC = +0.0000/-0.0016

DCON = h₆

RE = +0.0000/-0.0020

>3/8-1 DIAMETER

DC = +0.0000/-0.0020

DCON = h₆

RE = +0.0000/-0.0020

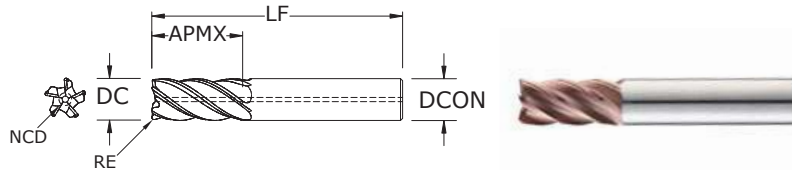

Z5 • Z5CR
FRACTIONAL SERIES

inch						EDP NO.					
CUTTING DIAMETER DC	LENGTH OF CUT APMX	OVERALL LENGTH LF	SHANK DIAMETER DCON	CORNER RADIUS RE	NON-CUTTING CENTER DIAMETER NCD	TI-NAMITE-A (TA)	TI-NAMITE-A (TA) W/FLAT	TI-NAMITE-A (TA) W/INTERNAL COOLANT	TI-NAMITE-M (TM)	TI-NAMITE-M (TM) W/FLAT	TI-NAMITE-M (TM) W/INTERNAL COOLANT
5/16	7/16	2-1/2	5/16	-	0.1090	38503	-	-	37014	-	-
5/16	7/16	2-1/2	5/16	0.010	0.1090	38799	-	-	38798	-	-
5/16	7/16	2-1/2	5/16	0.015	0.1090	38529	-	-	37015	-	-
5/16	7/16	2-1/2	5/16	0.030	0.1090	38801	-	-	38800	-	-
5/16	7/16	2-1/2	5/16	0.060	0.1090	38803	-	-	38802	-	-
5/16	7/16	2-1/2	5/16	0.090	0.0640	38805	-	-	38804	-	-
5/16	5/8	2-1/2	5/16	-	0.1090	38504	-	-	37016	-	-
5/16	5/8	2-1/2	5/16	0.010	0.0640	38807	-	-	38806	-	-
5/16	5/8	2-1/2	5/16	0.015	0.1090	38530	-	-	37017	-	-
5/16	5/8	2-1/2	5/16	0.030	0.1090	38809	-	-	38808	-	-
5/16	5/8	2-1/2	5/16	0.060	0.1090	38811	-	-	38810	-	-
5/16	5/8	2-1/2	5/16	0.090	0.0640	38813	-	-	38812	-	-
3/8	1/2	2-1/2	3/8	-	0.1310	38505	-	-	37018	-	-
3/8	1/2	2-1/2	3/8	0.010	0.1310	38815	-	-	38814	-	-
3/8	1/2	2-1/2	3/8	0.015	0.1310	38531	-	-	37019	-	-
3/8	1/2	2-1/2	3/8	0.030	0.1310	38532	-	-	37020	-	-
3/8	1/2	2-1/2	3/8	0.060	0.1310	38817	-	-	38816	-	-
3/8	1/2	2-1/2	3/8	0.090	0.0830	38819	-	-	38818	-	-
3/8	3/4	2-1/2	3/8	-	0.1310	37187	-	-	37021	-	-
3/8	3/4	2-1/2	3/8	0.010	0.1310	38821	-	-	38820	-	-
3/8	3/4	2-1/2	3/8	0.015	0.1310	37188	-	-	37022	-	-
3/8	3/4	2-1/2	3/8	0.030	0.1310	37189	37174	-	37023	-	-
3/8	3/4	2-1/2	3/8	0.060	0.1310	38823	-	-	38822	-	-
3/8	3/4	2-1/2	3/8	0.090	0.0830	38825	-	-	38824	-	-
7/16	5/8	2-1/2	7/16	0.015	0.1530	37164	-	-	37160	-	-
7/16	5/8	2-1/2	7/16	0.030	0.1530	37165	-	-	37161	-	-
7/16	7/8	2-3/4	7/16	0.015	0.1530	37166	-	-	37162	-	-
7/16	7/8	2-3/4	7/16	0.030	0.1530	37167	-	-	37163	-	-

CONTINUED

continued on next page

FRACTIONAL Z-Carb-HPR

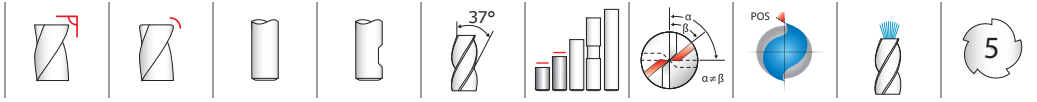

Z5 • Z5CR FRACTIONAL SERIES

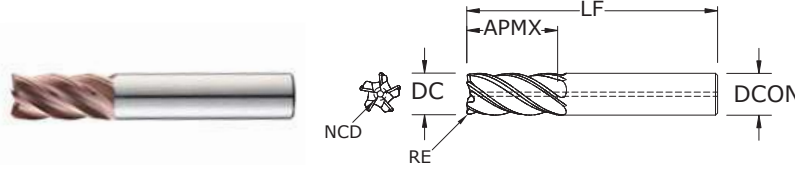

TOLERANCES (inch)

1/8-1/4 DIAMETER
DC = +0.0000/-0.0012
DCON = h ₆
RE = +0.0000/-0.0020
>1/4-3/8 DIAMETER
DC = +0.0000/-0.0016
DCON = h ₆
RE = +0.0000/-0.0020
>3/8-1 DIAMETER
DC = +0.0000/-0.0020
DCON = h ₆
RE = +0.0000/-0.0020

CONTINUED

- An ideal balance of helix, indexing, flute depth, rake and relief
- Variable indexing for chatter suppression and patented edge geometry for shearing and strength
- Chatter-free geometry allows deep cutting and high speed machining
- Central coolant hole delivers coolant effectively to the cutting zone enhancing chip removal when pocketing or slotting
- Excels at roughing, ramping, high speed machining and finishing in a variety of materials
- Enhanced corner geometry with tight tolerance corner radii
- Recommended for materials ≤ 45 HRc (≤ 420 Bhn)

- STEELS
- STAINLESS STEELS
- CAST IRON
- HIGH TEMP ALLOYS
- TITANIUM
- HARDENED STEELS

For patent information visit www.kspatents.com

inch						EDP NO.					
CUTTING DIAMETER DC	LENGTH OF CUT APMX	OVERALL LENGTH LF	SHANK DIAMETER DCON	CORNER RADIUS RE	NON-CUTTING CENTER DIAMETER NCD	TI-NAMITE-A (TA)	TI-NAMITE-A (TA) W/FLAT	TI-NAMITE-A (TA) W/INTERNAL COOLANT	TI-NAMITE-M (TM)	TI-NAMITE-M (TM) W/FLAT	TI-NAMITE-M (TM) W/INTERNAL COOLANT
1/2	5/8	3	1/2	-	0.1750	38506	38512	37320	37024	37030	37321
1/2	5/8	3	1/2	0.010	0.1750	38827	38829	38831	38826	38828	38830
1/2	5/8	3	1/2	0.015	0.1750	38533	38578	37330	37025	37031	37331
1/2	5/8	3	1/2	0.030	0.1750	38534	38579	37332	37026	37032	37333
1/2	5/8	3	1/2	0.060	0.1750	38535	38580	37334	37027	37033	37335
1/2	5/8	3	1/2	0.090	0.1750	38536	38581	37337	37028	37034	37338
1/2	5/8	3	1/2	0.120	0.1750	38537	38582	37339	37029	37035	37340
1/2	1	3	1/2	-	0.1750	38507	38513	37322	37036	37042	37323
1/2	1	3	1/2	0.010	0.1750	38833	38835	38837	38832	38834	38836
1/2	1	3	1/2	0.015	0.1750	38538	38583	37341	37037	37043	37342
1/2	1	3	1/2	0.030	0.1750	38539	38584	37343	37038	37044	37344
1/2	1	3	1/2	0.060	0.1750	38540	38585	37345	37039	37045	37346
1/2	1	3	1/2	0.090	0.1750	38541	38586	37348	37040	37046	37349
1/2	1	3	1/2	0.120	0.1750	38542	38587	37350	37041	37047	37351
1/2	1-1/4	3-1/4	1/2	-	0.1750	37190	37194	37325	37048	37054	37324
1/2	1-1/4	3-1/4	1/2	0.010	0.1750	38839	38841	38843	38838	38840	38842
1/2	1-1/4	3-1/4	1/2	0.015	0.1750	37191	37195	37352	37049	37055	37353
1/2	1-1/4	3-1/4	1/2	0.030	0.1750	37192	37196	37354	37050	37056	37355
1/2	1-1/4	3-1/4	1/2	0.060	0.1750	37193	37197	37356	37051	37057	37357
1/2	1-1/4	3-1/4	1/2	0.090	0.1750	38543	38588	37359	37052	37058	37360
1/2	1-1/4	3-1/4	1/2	0.120	0.1750	38544	38589	37361	37053	37059	37362
5/8	3/4	3-1/2	5/8	-	0.2630	38508	38514	38518	37060	37067	37260
5/8	3/4	3-1/2	5/8	0.010	0.2190	38845	38847	38849	38844	38846	38848
5/8	3/4	3-1/2	5/8	0.015	0.2190	38545	38590	38623	37061	37068	37261
5/8	3/4	3-1/2	5/8	0.030	0.2190	38546	38591	38624	37062	37069	37262
5/8	3/4	3-1/2	5/8	0.060	0.2190	38547	38592	38625	37063	37070	37263
5/8	3/4	3-1/2	5/8	0.090	0.2190	38548	38593	38626	37064	37071	37264
5/8	3/4	3-1/2	5/8	0.120	0.2190	38549	38594	38627	37065	37072	37265
5/8	3/4	3-1/2	5/8	0.190	0.2190	38550	38595	38628	37066	37073	37266
5/8	1-1/4	3-1/2	5/8	-	0.2190	37198	37202	38519	37074	37081	37267

continued on next page



FRACTIONAL Z-Carb-HPR

TOLERANCES (inch)

1/8–1/4 DIAMETER

DC = +0.0000/–0.0012

DCON = h_6

RE = +0.0000/–0.0020

>1/4–3/8 DIAMETER

DC = +0.0000/–0.0016

DCON = h_6

RE = +0.0000/–0.0020

>3/8–1 DIAMETER

DC = +0.0000/–0.0020

DCON = h_6

RE = +0.0000/–0.0020

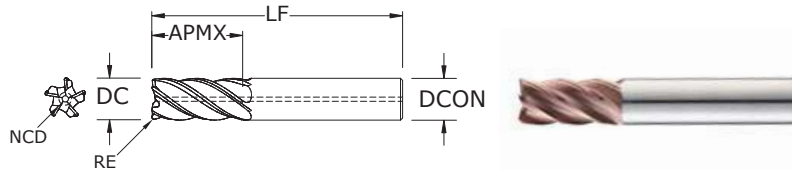
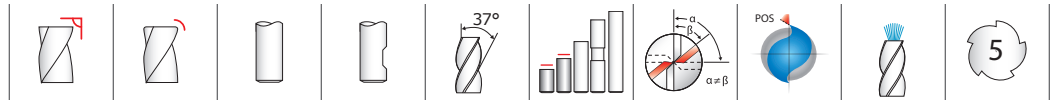

Z5 • Z5CR FRACTIONAL SERIES

inch						EDP NO.					
CUTTING DIAMETER DC	LENGTH OF CUT APMX	OVERALL LENGTH LF	SHANK DIAMETER DCON	CORNER RADIUS RE	NON-CUTTING CENTER DIAMETER NCD	TI-NAMITE-A (TA)	TI-NAMITE-A (TA) W/FLAT	TI-NAMITE-A (TA) W/INTERNAL COOLANT	TI-NAMITE-M (TM)	TI-NAMITE-M (TM) W/FLAT	TI-NAMITE-M (TM) W/INTERNAL COOLANT
5/8	1-1/4	3-1/2	5/8	0.010	0.2190	38851	38853	38855	38850	38852	38854
5/8	1-1/4	3-1/2	5/8	0.015	0.2190	37199	37203	38629	37075	37082	37268
5/8	1-1/4	3-1/2	5/8	0.030	0.2190	37200	37204	38630	37076	37083	37269
5/8	1-1/4	3-1/2	5/8	0.060	0.2190	37201	37205	38631	37077	37084	37270
5/8	1-1/4	3-1/2	5/8	0.090	0.2190	38551	38596	38632	37078	37085	37271
5/8	1-1/4	3-1/2	5/8	0.120	0.2190	38552	38597	38633	37079	37086	37272
5/8	1-1/4	3-1/2	5/8	0.190	0.2190	38553	38598	38634	37080	37087	37273
3/4	7/8	4	3/4	–	0.2630	38509	38515	38520	37088	37095	37274
3/4	7/8	4	3/4	0.010	0.2630	38857	38859	38861	38856	38858	38860
3/4	7/8	4	3/4	0.030	0.2630	38554	38599	38635	37089	37096	37275
3/4	7/8	4	3/4	0.060	0.2630	38555	38600	38636	37090	37097	37276
3/4	7/8	4	3/4	0.090	0.2630	38556	38601	38637	37091	37098	37277
3/4	7/8	4	3/4	0.120	0.2630	38557	38602	38638	37092	37099	37278
3/4	7/8	4	3/4	0.190	0.2630	38558	38603	38639	37093	37100	37279
3/4	7/8	4	3/4	0.250	0.2630	38559	38604	38640	37094	37101	37280
3/4	1-1/2	4	3/4	–	0.2630	37206	37210	38521	37102	37109	37281
3/4	1-1/2	4	3/4	0.010	0.2630	38863	38865	38867	38862	38864	38866
3/4	1-1/2	4	3/4	0.030	0.2630	37207	37211	38641	37103	37110	37282
3/4	1-1/2	4	3/4	0.060	0.2630	37208	37212	38642	37104	37111	37283
3/4	1-1/2	4	3/4	0.090	0.2630	38560	38605	38643	37105	37112	37284
3/4	1-1/2	4	3/4	0.120	0.2630	37209	37213	38644	37106	37113	37285
3/4	1-1/2	4	3/4	0.190	0.2630	38561	38606	38645	37107	37114	37286
3/4	1-1/2	4	3/4	0.250	0.2630	38562	38607	38646	37108	37115	37287
3/4	1-5/8	4	3/4	0.030	0.2630	37222	–	–	37223	–	–
3/4	1-5/8	4	3/4	0.060	0.2630	37224	–	–	37225	–	–
3/4	1-5/8	4	3/4	0.090	0.2630	37226	–	–	37227	–	–
3/4	1-5/8	4	3/4	0.120	0.2630	37228	–	–	37229	–	–
3/4	2	4-1/2	3/4	0.030	0.2630	37230	–	–	37231	–	–
3/4	2	4-1/2	3/4	0.060	0.2630	37232	–	–	37233	–	–
3/4	2	4-1/2	3/4	0.090	0.2630	37234	–	–	37235	–	–

continued on next page

FRACTIONAL Z-Carb-HPR

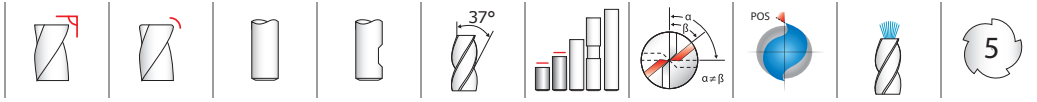

Z5 • Z5CR FRACTIONAL SERIES

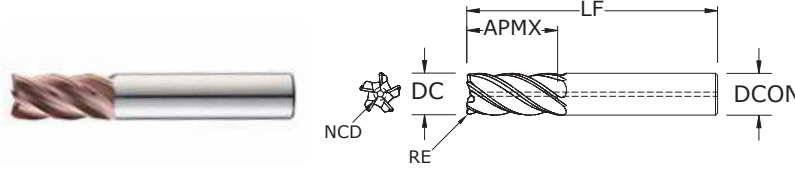

TOLERANCES (inch)

1/8–1/4 DIAMETER
DC = +0.0000/–0.0012
DCON = h_6
RE = +0.0000/–0.0020
>1/4–3/8 DIAMETER
DC = +0.0000/–0.0016
DCON = h_6
RE = +0.0000/–0.0020
>3/8–1 DIAMETER
DC = +0.0000/–0.0020
DCON = h_6
RE = +0.0000/–0.0020

CONTINUED

- An ideal balance of helix, indexing, flute depth, rake and relief
- Variable indexing for chatter suppression and patented edge geometry for shearing and strength
- Chatter-free geometry allows deep cutting and high speed machining
- Central coolant hole delivers coolant effectively to the cutting zone enhancing chip removal when pocketing or slotting
- Excels at roughing, ramping, high speed machining and finishing in a variety of materials
- Enhanced corner geometry with tight tolerance corner radii
- Recommended for materials ≤ 45 HRC (≤ 420 Bhn)

- STEELS
- STAINLESS STEELS
- CAST IRON
- HIGH TEMP ALLOYS
- TITANIUM
- HARDENED STEELS

For patent information visit www.kspatents.com

inch						EDP NO.					
CUTTING DIAMETER DC	LENGTH OF CUT APMX	OVERALL LENGTH LF	SHANK DIAMETER DCON	CORNER RADIUS RE	NON-CUTTING CENTER DIAMETER NCD	TI-NAMITE-A (TA)	TI-NAMITE-A (TA) W/FLAT	TI-NAMITE-A (TA) W/INTERNAL COOLANT	TI-NAMITE-M (TM)	TI-NAMITE-M (TM) W/FLAT	TI-NAMITE-M (TM) W/INTERNAL COOLANT
3/4	2	4-1/2	3/4	0.120	0.2630	37236	–	–	37237	–	–
1	1-1/8	4	1	–	0.3500	38510	38516	38522	37116	37123	37288
1	1-1/8	4	1	0.010	0.3500	38869	38871	38873	38868	38870	38872
1	1-1/8	4	1	0.030	0.3500	38563	38608	38647	37117	37124	37289
1	1-1/8	4	1	0.060	0.3500	38564	38609	38648	37118	37125	37290
1	1-1/8	4	1	0.090	0.3500	38565	38610	38649	37119	37126	37291
1	1-1/8	4	1	0.120	0.3500	38566	38611	38650	37120	37127	37292
1	1-1/8	4	1	0.190	0.3500	38567	38612	38651	37121	37128	37293
1	1-1/8	4	1	0.250	0.3500	38568	38613	38652	37122	37129	37294
1	1-1/2	4	1	–	0.3500	37214	37218	38523	37130	37137	37295
1	1-1/2	4	1	0.010	0.3500	38875	38877	38879	38874	38876	38878
1	1-1/2	4	1	0.030	0.3500	37215	37219	38653	37131	37138	37296
1	1-1/2	4	1	0.060	0.3500	37216	37220	38654	37132	37139	37297
1	1-1/2	4	1	0.090	0.3500	38569	38614	38655	37133	37140	37298
1	1-1/2	4	1	0.120	0.3500	37217	37221	38656	37134	37141	37299
1	1-1/2	4	1	0.190	0.3500	38570	38615	38657	37135	37142	37300
1	1-1/2	4	1	0.250	0.3500	38571	38616	38658	37136	37143	37301
1	2	4-1/2	1	–	0.3500	38511	38517	38524	37144	37151	37302
1	2	4-1/2	1	0.010	0.3500	38881	38883	38885	38880	38882	38884
1	2	4-1/2	1	0.030	0.3500	38572	38617	38659	37145	37152	37303
1	2	4-1/2	1	0.060	0.3500	38573	38618	38660	37146	37153	37304
1	2	4-1/2	1	0.090	0.3500	38574	38619	38661	37147	37154	37305
1	2	4-1/2	1	0.120	0.3500	38575	38620	38662	37148	37155	37306
1	2	4-1/2	1	0.190	0.3500	38576	38621	38663	37149	37156	37307
1	2	4-1/2	1	0.250	0.3500	38577	38622	38664	37150	37157	37308

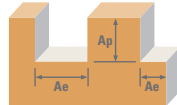

Series Z5, Z5CR Fractional	Hardness	Profile Ae x DC	Slot Ap x DC	Vc (sfm)	DC • in								
					1/8	1/4	3/8	1/2	5/8	3/4	1		
P CARBON STEELS 1018, 1040, 1080, 1090, 10L50, 1140, 1212, 12L15, 1525, 1536	≤ 275 Bhn or ≤ 28 HRc	Profile 	≤ 0.5	≤ 1.5	555 (444-666)	RPM	16961	8480	5654	4240	3392	2827	2120
						Fz	0.00046	0.0012	0.0023	0.0031	0.0034	0.0037	0.0043
						Feed (ipm)	39.0	50.9	65.0	65.7	57.7	52.3	45.6
	≤ 375 Bhn or ≤ 40 HRc	Slot 	1	≤ 1	440 (352-528)	RPM	13446	6723	4482	3362	2689	2241	1681
						Fz	0.00046	0.0012	0.0023	0.0031	0.0034	0.0037	0.0043
						Feed (ipm)	30.9	40.3	51.5	52.1	45.7	41.5	36.1
K CAST IRONS (LOW & MEDIUM ALLOY) Gray, Malleable, Ductile	≤ 220 Bhn or ≤ 19 HRc	Profile 	≤ 0.5	≤ 1.5	445 (356-534)	RPM	9626	4813	3209	2407	1925	1604	1203
						Fz	0.00034	0.0009	0.0017	0.0023	0.0026	0.0028	0.0032
						Feed (ipm)	16.4	21.7	27.3	27.7	25.0	22.5	19.3
	≤ 260 Bhn or ≤ 26 HRc	Slot 	1	≤ 1	250 (200-300)	RPM	7640	3820	2547	1910	1528	1273	955
						Fz	0.00034	0.0009	0.0017	0.0023	0.0026	0.0028	0.0032
						Feed (ipm)	13.0	17.2	21.6	22.0	19.9	17.8	15.3
M CAST IRONS (HIGH ALLOY) Gray, Malleable, Ductile	≤ 220 Bhn or ≤ 19 HRc	Profile 	≤ 0.5	≤ 1.5	445 (356-534)	RPM	13599	6800	4533	3400	2720	2267	1700
						Fz	0.00042	0.0011	0.0021	0.0028	0.0031	0.0034	0.0039
						Feed (ipm)	28.6	37.4	47.6	47.6	42.2	38.5	33.1
	≤ 260 Bhn or ≤ 26 HRc	Slot 	1	≤ 1	355 (284-426)	RPM	10849	5424	3616	2712	2170	1808	1356
						Fz	0.00042	0.0011	0.0021	0.0028	0.0031	0.0034	0.0039
						Feed (ipm)	22.8	29.8	38.0	38.0	33.6	30.7	26.4
M CAST IRONS (HIGH ALLOY) Gray, Malleable, Ductile	≤ 260 Bhn or ≤ 26 HRc	Profile 	≤ 0.5	≤ 1.5	340 (272-408)	RPM	10390	5195	3463	2598	2078	1732	1299
						Fz	0.00031	0.0008	0.0016	0.0021	0.0023	0.0025	0.0029
						Feed (ipm)	16.1	21.8	27.7	27.3	23.9	21.6	18.8
	≤ 275 Bhn or ≤ 28 HRc	Slot 	1	≤ 1	270 (216-324)	RPM	8251	4126	2750	2063	1650	1375	1031
						Fz	0.00031	0.0008	0.0016	0.0021	0.0023	0.0025	0.0029
						Feed (ipm)	12.8	17.3	22.0	21.7	19.0	17.2	15.0
M STAINLESS STEELS (FREE MACHINING) 303, 416, 420F, 430F, 440F	≤ 275 Bhn or ≤ 28 HRc	Profile 	≤ 0.5	≤ 1.5	490 (392-588)	RPM	14974	7487	4991	3744	2995	2496	1872
						Fz	0.00034	0.0009	0.0017	0.0023	0.0026	0.0028	0.0032
						Feed (ipm)	25.5	33.7	42.4	43.1	38.9	34.9	29.9
	≤ 275 Bhn or ≤ 28 HRc	Slot 	1	≤ 1	390 (312-468)	RPM	11918	5959	3973	2980	2384	1986	1490
						Fz	0.00034	0.0009	0.0017	0.0023	0.0026	0.0028	0.0032
						Feed (ipm)	20.3	26.8	33.8	34.3	31.0	27.8	23.8
M STAINLESS STEELS (DIFFICULT) 304, 304L, 316, 316L	≤ 275 Bhn or ≤ 28 HRc	Profile 	≤ 0.5	≤ 1.5	340 (272-408)	RPM	10390	5195	3463	2598	2078	1732	1299
						Fz	0.00027	0.0007	0.0014	0.0018	0.0020	0.0022	0.0025
						Feed (ipm)	14.0	18.2	24.2	23.4	20.8	19.0	16.2
	≤ 325 Bhn or ≤ 35 HRc	Slot 	1	≤ 1	270 (216-324)	RPM	8251	4126	2750	2063	1650	1375	1031
						Fz	0.00027	0.0007	0.0014	0.0018	0.0020	0.0022	0.0025
						Feed (ipm)	11.1	14.4	19.3	18.6	16.5	15.1	12.9
M STAINLESS STEELS (PH) 13-8 PH, 15-5PH, 17-4 PH, CUSTOM 450	≤ 325 Bhn or ≤ 35 HRc	Profile 	≤ 0.5	≤ 1.5	310 (248-372)	RPM	9474	4737	3158	2368	1895	1579	1184
						Fz	0.00027	0.0007	0.0014	0.0018	0.0020	0.0022	0.0025
						Feed (ipm)	12.8	16.6	22.1	21.3	18.9	17.4	14.8
	≤ 325 Bhn or ≤ 35 HRc	Slot 	1	≤ 1	250 (200-300)	RPM	7640	3820	2547	1910	1528	1273	955
						Fz	0.00027	0.0007	0.0014	0.0018	0.0020	0.0022	0.0025
						Feed (ipm)	10.3	13.4	17.8	17.2	15.3	14.0	11.9

continued on next page

FRACTIONAL Z-Carb-HPR

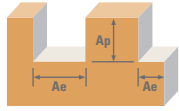

Series Z5, Z5CR Fractional	Hardness	Profile Ae x DC	Ap x DC	Vc (sfm)	DC • in								
					1/8	1/4	3/8	1/2	5/8	3/4	1		
S	SUPER ALLOYS (NICKEL, COBALT, IRON BASE) Inconel 601, 617, 625, Incoloy, Monel 400	Profile Ae x DC	≤ 0.5	≤ 1.5	80 (64-96)	RPM	2445	1222	815	611	489	407	306
						Fz	0.00025	0.00068	0.00128	0.00170	0.00187	0.00204	0.00238
						Feed (ipm)	3.1	4.2	5.2	5.2	4.6	4.2	3.6
		Slot Ae x DC	1	≤ 1	65 (52-78)	RPM	1986	993	662	497	397	331	248
						Fz	0.00025	0.00068	0.00128	0.00170	0.00187	0.00204	0.00238
						Feed (ipm)	2.5	3.4	4.2	4.2	3.7	3.4	3.0
	SUPER ALLOYS (NICKEL, COBALT, IRON BASE) Inconel 718, X-750, Incoloy, Waspaloy, Hastelloy, Rene	Profile Ae x DC	≤ 0.5	≤ 1.5	62 (50-74)	RPM	1895	947	632	474	379	316	237
						Fz	0.00018	0.00048	0.00090	0.00120	0.00130	0.00140	0.00170
						Feed (ipm)	1.7	2.3	2.8	2.8	2.5	2.2	2.0
		Slot Ae x DC	1	≤ 1	50 (40-60)	RPM	1528	764	509	382	306	255	191
						Fz	0.00018	0.00048	0.00090	0.00120	0.00130	0.00140	0.00170
						Feed (ipm)	1.4	1.8	2.3	2.3	2.0	1.8	1.6
TITANIUM ALLOYS Pure Titanium, Ti6Al4V, Ti6Al2Sn4Zr2Mo, Ti4Al4Mo2Sn0.5Si	Profile Ae x DC	≤ 0.5	≤ 1.5	215 (172-258)	RPM	6570	3285	2190	1643	1314	1095	821	
					Fz	0.0003	0.0008	0.0015	0.0020	0.0022	0.0024	0.0028	
					Feed (ipm)	9.9	13.1	16.4	16.4	14.5	13.1	11.5	
	Slot Ae x DC	1	≤ 1	170 (136-204)	RPM	5195	2598	1732	1299	1039	866	649	
					Fz	0.0003	0.0008	0.0015	0.0020	0.0022	0.0024	0.0028	
					Feed (ipm)	7.8	10.4	13.0	13.0	11.4	10.4	9.1	
TITANIUM ALLOYS (DIFFICULT) Ti10Al2Fe3Al, Ti5Al5V5Mo3Cr, Ti7Al4Mo, Ti3Al8V6Cr4Zr4Mo, Ti6Al6V6Sn, Ti15V3 Cr3Sn3Al	Profile Ae x DC	≤ 0.5	≤ 1.5	75 (60-90)	RPM	2292	1146	764	573	458	382	287	
					Fz	0.0003	0.0008	0.0015	0.0020	0.0022	0.0024	0.0028	
					Feed (ipm)	3.4	4.6	5.7	5.7	5.0	4.6	4.0	
	Slot Ae x DC	1	≤ 1	60 (48-72)	RPM	1834	917	611	458	367	306	229	
					Fz	0.0003	0.0008	0.0015	0.0020	0.0022	0.0024	0.0028	
					Feed (ipm)	2.8	3.7	4.6	4.6	4.0	3.7	3.2	
H	TOOL STEELS A2, D2, H13, L2, M2, P20, S7, T15, W2	Profile Ae x DC	≤ 0.5	≤ 1.5	185 (148-222)	RPM	5654	2827	1885	1413	1131	942	707
						Fz	0.00028	0.0007	0.0014	0.0018	0.0020	0.0022	0.0026
						Feed (ipm)	7.9	9.9	13.2	12.7	11.3	10.4	9.2
		Slot Ae x DC	1	≤ 1	145 (116-174)	RPM	4431	2216	1477	1108	886	739	554
						Fz	0.00028	0.0007	0.0014	0.0018	0.0020	0.0022	0.0026
						Feed (ipm)	6.2	7.8	10.3	10.0	8.9	8.1	7.2

Bhn (Brinell) HRc (Rockwell C)

rpm = Vc x 3.82 / DC

ipm = Fz x 5 x rpm

ramp up to 5 degrees using slotting speed and feed rates. Do not plunge.

reduce speed and feed for materials harder than listed

reduce feed and Ae when finish milling (.02 x DC maximum)

feed rates listed have chip thinning adjustments included where applicable

refer to the SGS Tool Wizard® for complete technical information (www.kyocera-sgstool.com)

TOLERANCES (mm)

6 DIAMETER

DC = +0,000/-0,030

DCON = h₆

RE = +0,000/-0,050

>6-10 DIAMETER

DC = +0,000/-0,040

DCON = h₆

RE = +0,000/-0,050

>10-25 DIAMETER

DC = +0,000/-0,050

DCON = h₆

RE = +0,000/-0,050

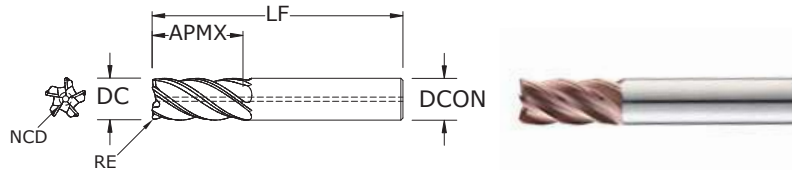
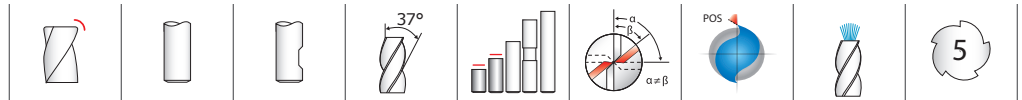

Z5MCR
METRIC SERIES

mm						EDP NO.					
CUTTING DIAMETER DC	LENGTH OF CUT APMX	OVERALL LENGTH LF	SHANK DIAMETER DCON	CORNER RADIUS RE	NON-CUTTING CENTER DIAMETER NCD	TI-NAMITE-A (TA)	TI-NAMITE-A (TA) W/FLAT	TI-NAMITE-A (TA) W/INTERNAL COOLANT	TI-NAMITE-M (TM)	TI-NAMITE-M (TM) W/FLAT	TI-NAMITE-M (TM) W/INTERNAL COOLANT
6,0	9,0	54,0	6,0	0,5	2,11	48000	-	-	47000	-	-
6,0	13,0	57,0	6,0	0,3	2,11	48001	-	-	47001	-	-
6,0	13,0	57,0	6,0	0,5	2,11	47120	-	-	47002	-	-
6,0	13,0	57,0	6,0	1,0	2,11	48002	-	-	47003	-	-
6,0	13,0	57,0	6,0	1,5	2,11	48003	-	-	47004	-	-
8,0	11,0	58,0	8,0	0,5	2,79	48004	-	-	47005	-	-
8,0	18,0	63,0	8,0	0,5	2,79	47121	-	-	47006	-	-
8,0	18,0	63,0	8,0	1,0	2,79	47122	-	-	47007	-	-
8,0	18,0	63,0	8,0	1,5	2,79	48005	-	-	47008	-	-
8,0	18,0	63,0	8,0	2,0	2,79	48006	-	-	47009	-	-
10,0	13,0	66,0	10,0	1,0	2,79	48007	-	-	47010	-	-
10,0	22,0	72,0	10,0	0,5	3,51	47123	-	-	47011	-	-
10,0	22,0	72,0	10,0	1,0	3,51	47124	-	-	47012	-	-
10,0	22,0	72,0	10,0	1,5	3,51	48008	-	-	47013	-	-
10,0	22,0	72,0	10,0	2,0	3,51	48009	-	-	47014	-	-
10,0	22,0	72,0	10,0	2,5	3,51	48010	-	-	47015	-	-
12,0	15,0	73,0	12,0	1,0	4,19	48011	48029	-	47016	47024	-
12,0	26,0	83,0	12,0	0,5	4,19	47125	47128	47160	47017	47025	47161
12,0	26,0	83,0	12,0	0,76	4,19	47126	47129	47162	47018	47026	47163
12,0	26,0	83,0	12,0	1,0	4,19	47127	47130	47164	47019	47027	47165
12,0	26,0	83,0	12,0	1,5	4,19	48012	48030	47166	47020	47028	47167
12,0	26,0	83,0	12,0	2,0	4,19	48013	48031	47168	47021	47029	47169
12,0	26,0	83,0	12,0	2,5	4,19	48014	48032	47170	47022	47030	47171
12,0	26,0	83,0	12,0	3,0	4,19	48015	48033	47172	47023	47031	47173
16,0	19,0	82,0	16,0	1,0	5,59	48016	48034	48056	47032	47039	47046
16,0	19,0	82,0	16,0	1,5	5,59	48070	-	-	48071	-	-
16,0	35,0	92,0	16,0	1,0	5,59	47131	48035	47134	47033	47040	47047
16,0	35,0	92,0	16,0	1,5	5,59	48017	48036	48057	47034	47041	47048

- An ideal balance of helix, indexing, flute depth, rake and relief
- Variable indexing for chatter suppression and patented edge geometry for shearing and strength
- Chatter-free geometry allows deep cutting and high speed machining
- Central coolant hole delivers coolant effectively to the cutting zone enhancing chip removal when pocketing or slotting
- Enhanced corner geometry with tight tolerance corner radii
- Excels at roughing, ramping, high speed machining and finishing in a variety of materials
- Recommended for materials ≤ 45 HRC (≤ 420 Bhn)

- STEELS
- STAINLESS STEELS
- CAST IRON
- HIGH TEMP ALLOYS
- TITANIUM
- HARDENED STEELS

For patent information visit www.ksptpatents.com

continued on next page

METRIC Z-Carb-HPR

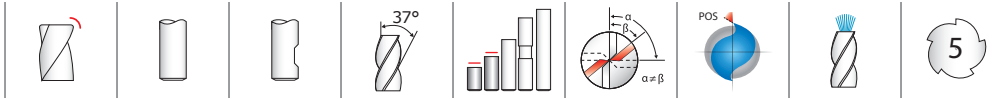

TOLERANCES (mm)

6 DIAMETER
DC = +0,000/-0,030
DCON = h_6
RE = +0,000/-0,050
>6-10 DIAMETER
DC = +0,000/-0,040
DCON = h_6
RE = +0,000/-0,050
>10-25 DIAMETER
DC = +0,000/-0,050
DCON = h_6
RE = +0,000/-0,050

Z5MCR METRIC SERIES

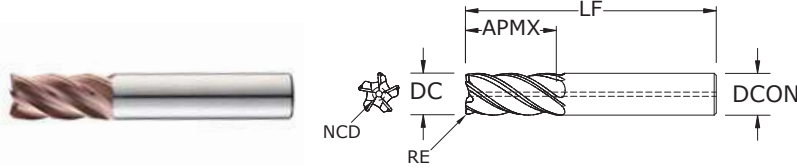

CONTINUED

- An ideal balance of helix, indexing, flute depth, rake and relief
- Variable indexing for chatter suppression and patented edge geometry for shearing and strength
- Chatter-free geometry allows deep cutting and high speed machining
- Central coolant hole delivers coolant effectively to the cutting zone enhancing chip removal when pocketing or slotting
- Enhanced corner geometry with tight tolerance corner radii
- Excels at roughing, ramping, high speed machining and finishing in a variety of materials
- Recommended for materials ≤ 45 HRC (≤ 420 Bhn)

- STEELS
- STAINLESS STEELS
- CAST IRON
- HIGH TEMP ALLOYS
- TITANIUM
- HARDENED STEELS

For patent information visit www.ksptpatents.com

mm						EDP NO.					
CUTTING DIAMETER DC	LENGTH OF CUT APMX	OVERALL LENGTH LF	SHANK DIAMETER DCON	CORNER RADIUS RE	NON-CUTTING CENTER DIAMETER NCD	TI-NAMITE-A (TA)	TI-NAMITE-A (TA) W/FLAT	TI-NAMITE-A (TA) W/INTERNAL COOLANT	TI-NAMITE-M (TM)	TI-NAMITE-M (TM) W/FLAT	TI-NAMITE-M (TM) W/INTERNAL COOLANT
16,0	35,0	92,0	16,0	2,0	5,59	47132	48037	47135	47035	47042	47049
16,0	35,0	92,0	16,0	2,5	5,59	48018	48038	48058	47036	47043	47050
16,0	35,0	92,0	16,0	3,0	5,59	47133	48039	47136	47037	47044	47051
16,0	35,0	92,0	16,0	4,0	5,59	48019	48040	48059	47038	47045	47052
20,0	23,0	92,0	20,0	1,0	7,01	48020	48041	48060	47053	47061	47069
20,0	43,0	104,0	20,0	1,0	7,01	47137	48042	47140	47054	47062	47070
20,0	43,0	104,0	20,0	1,5	7,01	48021	48043	48061	47055	47063	47071
20,0	43,0	104,0	20,0	2,0	7,01	47138	48044	47141	47056	47064	47072
20,0	43,0	104,0	20,0	2,5	7,01	48022	48045	48062	47057	47065	47073
20,0	43,0	104,0	20,0	3,0	7,01	47139	48046	47142	47058	47066	47074
20,0	43,0	104,0	20,0	4,0	7,01	48023	48047	48063	47059	47067	47075
20,0	43,0	104,0	20,0	5,0	7,01	48024	48048	48064	47060	47068	47076
25,0	28,0	100,0	25,0	1,0	8,76	48025	48049	48065	47077	47084	47091
25,0	53,0	121,0	25,0	1,0	8,76	47143	48050	47146	47078	47085	47092
25,0	53,0	121,0	25,0	2,0	8,76	47144	48051	47147	47079	47086	47093
25,0	53,0	121,0	25,0	2,5	8,76	48026	48052	48066	47080	47087	47094
25,0	53,0	121,0	25,0	3,0	8,76	47145	48053	47148	47081	47088	47095
25,0	53,0	121,0	25,0	4,0	8,76	48027	48054	48067	47082	47089	47096
25,0	53,0	121,0	25,0	5,0	8,76	48028	48055	48068	47083	47090	47097

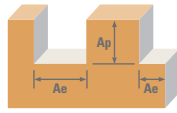

Series Z5MCR Metric	Hardness	Profile Ae x DC	Slot Ap x DC	Vc (m/min)	DC • mm								
					6	8	10	12	16	20	25		
P	CARBON STEELS 1018, 1040, 1080, 1090, 10L50, 1140, 1212, 12L15, 1525, 1536 ≤ 275 Bhn or ≤ 28 HRc	Profile Ae x DC	Slot Ap x DC	169 (135-203)	RPM	8967	6725	5380	4484	3363	2690	2152	
					Fz	0.029	0.049	0.061	0.074	0.087	0.099	0.108	
					Feed (mm/min)	1291	1650	1650	1668	1463	1327	1157	
		Slot Ap x DC	1	≤ 1	134 (107-161)	RPM	7109	5332	4265	3555	2666	2133	1706
						Fz	0.029	0.049	0.061	0.074	0.087	0.099	0.108
						Feed (mm/min)	1024	1308	1308	1322	1160	1052	917
K	ALLOY STEELS 4140, 4150, 4320, 5120, 5150, 8630, 86L20, 50100 ≤ 375 Bhn or ≤ 40 HRc	Profile Ae x DC	Slot Ap x DC	96 (77-115)	RPM	5089	3817	3054	2545	1909	1527	1221	
					Fz	0.022	0.036	0.045	0.055	0.067	0.075	0.080	
					Feed (mm/min)	550	692	692	702	635	570	489	
		Slot Ap x DC	1	≤ 1	76 (61-91)	RPM	4039	3029	2424	2020	1515	1212	969
						Fz	0.022	0.036	0.045	0.055	0.067	0.075	0.080
						Feed (mm/min)	436	549	549	557	504	452	388
M	CAST IRONS (LOW & MEDIUM ALLOY) Gray, Malleable, Ductile ≤ 220 Bhn or ≤ 19 HRc	Profile Ae x DC	Slot Ap x DC	136 (109-163)	RPM	7190	5392	4314	3595	2696	2157	1726	
					Fz	0.026	0.045	0.056	0.067	0.079	0.091	0.098	
					Feed (mm/min)	949	1208	1208	1208	1070	978	841	
		Slot Ap x DC	1	≤ 1	108 (87-130)	RPM	5736	4302	3441	2868	2151	1721	1377
						Fz	0.026	0.045	0.056	0.067	0.079	0.091	0.098
						Feed (mm/min)	757	964	964	964	853	780	671
M	CAST IRONS (HIGH ALLOY) Gray, Malleable, Ductile ≤ 260 Bhn or ≤ 26 HRc	Profile Ae x DC	Slot Ap x DC	104 (83-124)	RPM	5493	4120	3296	2747	2060	1648	1318	
					Fz	0.020	0.034	0.043	0.050	0.059	0.067	0.073	
					Feed (mm/min)	554	703	703	692	606	549	478	
		Slot Ap x DC	1	≤ 1	82 (66-99)	RPM	4362	3272	2617	2181	1636	1309	1047
						Fz	0.020	0.034	0.043	0.050	0.059	0.067	0.073
						Feed (mm/min)	440	558	558	550	482	436	380
M	STAINLESS STEELS (FREE MACHINING) 303, 416, 420F, 430F, 440F ≤ 275 Bhn or ≤ 28 HRc	Profile Ae x DC	Slot Ap x DC	149 (119-179)	RPM	7917	5938	4750	3958	2969	2375	1900	
					Fz	0.022	0.036	0.045	0.055	0.067	0.075	0.080	
					Feed (mm/min)	855	1077	1077	1092	988	887	760	
		Slot Ap x DC	1	≤ 1	119 (95-143)	RPM	6301	4726	3781	3151	2363	1890	1512
						Fz	0.022	0.036	0.045	0.055	0.067	0.075	0.080
						Feed (mm/min)	680	857	857	869	786	706	605
M	STAINLESS STEELS (DIFFICULT) 304, 304L, 316, 316L ≤ 275 Bhn or ≤ 28 HRc	Profile Ae x DC	Slot Ap x DC	104 (83-124)	RPM	5493	4120	3296	2747	2060	1648	1318	
					Fz	0.017	0.030	0.037	0.043	0.051	0.059	0.063	
					Feed (mm/min)	461	615	615	593	527	483	412	
		Slot Ap x DC	1	≤ 1	82 (66-99)	RPM	4362	3272	2617	2181	1636	1309	1047
						Fz	0.017	0.030	0.037	0.043	0.051	0.059	0.063
						Feed (mm/min)	366	489	489	471	419	384	327
M	STAINLESS STEELS (PH) 13-8 PH, 15-5PH, 17-4 PH, CUSTOM 450 ≤ 325 Bhn or ≤ 35 HRc	Profile Ae x DC	Slot Ap x DC	94 (76-113)	RPM	5009	3756	3005	2504	1878	1503	1202	
					Fz	0.017	0.030	0.037	0.043	0.051	0.059	0.063	
					Feed (mm/min)	421	561	561	541	481	441	376	
		Slot Ap x DC	1	≤ 1	76 (61-91)	RPM	4039	3029	2424	2020	1515	1212	969
						Fz	0.017	0.030	0.037	0.043	0.051	0.059	0.063
						Feed (mm/min)	339	452	452	436	388	355	303

continued on next page

Z-Carb-HPR

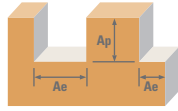

Series Z5MCR	Metric	Hardness	Ae x DC	Ap x DC	Vc (m/min)	DC • mm								
						6	8	10	12	16	20	25		
S	SUPER ALLOYS (NICKEL, COBALT, IRON BASE) Inconel 601, 617, 625, Incoloy, Monel 400	≤ 300 Bhn or ≤ 32 HRc	Profile 	≤ 0.5	≤ 1.5	24 (20-29)	RPM	1293	969	776	646	485	388	310
							Fz	0.0160	0.0272	0.0340	0.0409	0.0478	0.0531	0.0599
							Feed (mm/min)	103	132	132	132	116	103	93
			Slot 	1	≤ 1	20 (16-24)	RPM	1050	788	630	525	394	315	252
							Fz	0.0160	0.0272	0.0340	0.0409	0.0478	0.0531	0.0599
							Feed (mm/min)	84	107	107	107	94	84	75
	SUPER ALLOYS (NICKEL, COBALT, IRON BASE) Inconel 718, X-750, Incoloy, Waspaloy, Hastelloy, Rene	≤ 400 Bhn or ≤ 43 HRc	Profile 	≤ 0.5	≤ 1.5	19 (15-23)	RPM	1002	751	601	501	376	301	240
							Fz	0.0112	0.0192	0.0239	0.0284	0.0333	0.0371	0.0420
							Feed (mm/min)	56	72	72	71	63	56	50
			Slot 	1	≤ 1	15 (12-18)	RPM	808	606	485	404	303	242	194
							Fz	0.0112	0.0192	0.0239	0.0284	0.0333	0.0371	0.0420
							Feed (mm/min)	45	58	58	57	50	45	41
TITANIUM ALLOYS Pure Titanium, Ti6Al4V, Ti6Al2Sn4Zr2Mo, Ti4Al4Mo2Sn0.5Si	≤ 350 Bhn or ≤ 38 HRc	Profile 	≤ 0.5	≤ 1.5	66 (52-79)	RPM	3474	2605	2084	1737	1303	1042	834	
						Fz	0.019	0.032	0.040	0.048	0.056	0.064	0.070	
						Feed (mm/min)	333	417	417	417	367	333	292	
		Slot 	1	≤ 1	52 (41-62)	RPM	2747	2060	1648	1373	1030	824	659	
						Fz	0.019	0.032	0.040	0.048	0.056	0.064	0.070	
						Feed (mm/min)	264	330	330	330	290	264	231	
TITANIUM ALLOYS (DIFFICULT) Ti10Al2Fe3Al, Ti5Al5V5Mo3Cr, Ti7Al4Mo, Ti3Al8V6Cr4Zr4Mo, Ti6Al6V6Sn, Ti15V3 Cr3Sn3Al	≤ 440 Bhn or ≤ 47 HRc	Profile 	≤ 0.5	≤ 1.5	23 (18-27)	RPM	1212	909	727	606	454	364	291	
						Fz	0.019	0.032	0.040	0.048	0.056	0.064	0.071	
						Feed (mm/min)	116	145	145	145	128	116	103	
		Slot 	1	≤ 1	18 (15-22)	RPM	969	727	582	485	364	291	233	
						Fz	0.019	0.032	0.040	0.048	0.056	0.064	0.071	
						Feed (mm/min)	93	116	116	116	102	93	83	
H	TOOL STEELS A2, D2, H13, L2, M2, P20, S7, T15, W2	≤ 375 Bhn or ≤ 40 HRc	Profile 	≤ 0.5	≤ 1.5	56 (45-68)	RPM	2989	2242	1793	1495	1121	897	717
							Fz	0.017	0.030	0.037	0.043	0.051	0.059	0.065
							Feed (mm/min)	251	335	335	323	287	263	233
			Slot 	1	≤ 1	44 (35-53)	RPM	2343	1757	1406	1171	879	703	562
							Fz	0.017	0.030	0.037	0.043	0.051	0.059	0.065
							Feed (mm/min)	197	262	262	253	225	206	183

Bhn (Brinell) HRc (Rockwell C)
 rpm = (Vc x 1000) / (DC x 3.14)
 mm/min = Fz x 5 x rpm
 ramp up to 5 degrees using slotting speed and feed rates. Do not plunge.
 reduce speed and feed for materials harder than listed
 reduce feed and Ae when finish milling (.02 x DC maximum)
 feed rates listed have chip thinning adjustments included where applicable
 refer to the SGS Tool Wizard® for complete technical information (www.kyocera-sgstool.com)

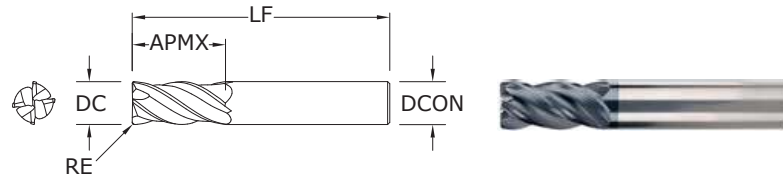
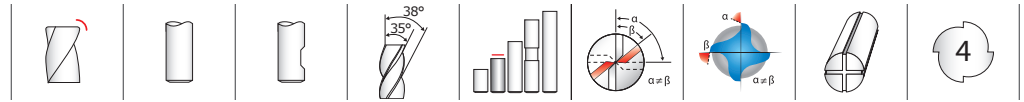

Z1PCR FRACTIONAL SERIES

TOLERANCES (inch)

<1/8 DIAMETER

DC = +0.0005/-0.0005

DCON = h_6

RE = +0.000/-0.0010

1/8-1/4 DIAMETER

DC = +0.000/-0.0012

DCON = h_6

RE = +0.000/-0.0020

>1/4-3/8 DIAMETER

DC = +0.000/-0.0016

DCON = h_6

RE = +0.000/-0.0020

>3/8-1 DIAMETER

DC = +0.000/-0.0020

DCON = h_6

RE = +0.000/-0.0020

STEELS

STAINLESS STEELS

CAST IRON

HIGH TEMP ALLOYS

TITANIUM

HARDENED STEELS

For patent
information visit
www.ksptpatents.com

CUTTING DIAMETER DC	LENGTH OF CUT APMX	inch			CORNER RADIUS RE	EDP NO.		
		OVERALL LENGTH LF	SHANK DIAMETER DCON			Ti-NAMITE-X	Ti-NAMITE-X W/FLAT	JetStream
1/64	1/32	1-1/2	1/8	.002	36874*	-	-	
1/32	5/64	1-1/2	1/8	.005	36875*	-	-	
3/64	7/64	1-1/2	1/8	.005	36876*	-	-	
1/16	3/16	1-1/2	1/8	.005	36872*	-	-	
5/64	3/16	1-1/2	1/8	.005	36877*	-	-	
3/32	9/32	1-1/2	1/8	.010	36873*	-	-	
7/64	3/8	1-1/2	1/8	.010	36878*	-	-	
1/8	3/8	1-1/2	1/8	.010	36370	-	-	
1/8	3/8	1-1/2	1/8	.015	36851	-	-	
3/16	7/16	2	3/16	.010	36371	-	-	
3/16	7/16	2	3/16	.015	36852	-	-	
3/16	7/16	2	3/16	.030	36722	-	-	
1/4	1/2	2-1/2	1/4	.010	36372	-	-	
1/4	1/2	2-1/2	1/4	.015	36723	-	-	
1/4	1/2	2-1/2	1/4	.020	36853	-	-	
1/4	1/2	2-1/2	1/4	.030	36373	-	-	
1/4	3/4	2-1/2	1/4	.010	36599	-	-	
1/4	3/4	2-1/2	1/4	.015	36600	-	-	
1/4	3/4	2-1/2	1/4	.020	36854	-	-	
1/4	3/4	2-1/2	1/4	.030	36601	-	-	
5/16	13/16	2-1/2	5/16	.015	36724	-	-	
5/16	13/16	2-1/2	5/16	.020	36855	-	-	
5/16	13/16	2-1/2	5/16	.030	36374	-	-	
3/8	7/8	2-1/2	3/8	.010	36375	36701	-	
3/8	7/8	2-1/2	3/8	.015	36725	36736	-	
3/8	7/8	2-1/2	3/8	.020	36856	36864	-	
3/8	7/8	2-1/2	3/8	.030	36376	36702	-	
3/8	7/8	2-1/2	3/8	.060	36727	36738	-	
7/16	1	2-3/4	7/16	.020	36857	36865	-	
1/2	1	3	1/2	.010	36378	36704	36804	
1/2	1	3	1/2	.015	36729	36740	36810	
1/2	1	3	1/2	.030	36858	36866	36805	
1/2	1	3	1/2	.060	36380	36706	36811	
1/2	1	3	1/2	.090	36381	36707	36812	

*Variable flute spacing. Helix and rake do not vary.

continued on next page

- Variable rake geometry alters and controls the cutting dynamic taking chatter suppression to an unprecedented level
- Unequal helix design changes the cutting angle to improve harmonics
- Unequal flute spacing helps to disrupt the rhythmic pattern created by the cutting edge helping to suppress damaging harmonics
- Enhanced corner geometry with tight tolerance corner radii
- Recommended for materials ≤ 45 HRC (≤ 420 Bhn)

FRACTIONAL Z-Carb-AP

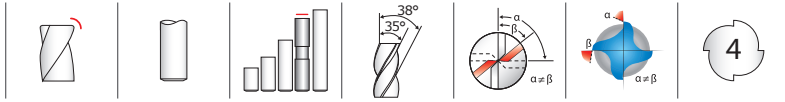

Z1PCR FRACTIONAL SERIES

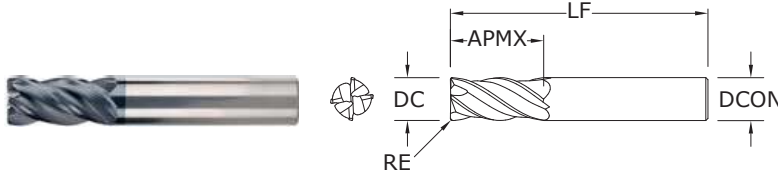

CONTINUED

CUTTING DIAMETER DC	LENGTH OF CUT APMX	inch			EDP NO.		
		OVERALL LENGTH LF	SHANK DIAMETER DCON	CORNER RADIUS RE	Ti-NAMITE-X	Ti-NAMITE-X W/FLAT	JetStream
1/2	1	3	1/2	.125	36731	36742	36813
1/2	1-1/4	3-1/4	1/2	.010	36602	36603	—
1/2	1-1/4	3-1/4	1/2	.015	36604	36605	—
1/2	1-1/4	3-1/4	1/2	.030	36859	36867	—
1/2	1-1/4	3-1/4	1/2	.060	36610	36611	—
1/2	1-1/4	3-1/4	1/2	.090	36612	36613	—
1/2	1-1/4	3-1/4	1/2	.125	36614	36615	—
9/16	1-1/8	3-1/2	9/16	.030	36860	36868	36806
5/8	1-1/4	3-1/2	5/8	.030	36383	36709	36814
5/8	1-1/4	3-1/2	5/8	.040	36861	36869	36807
5/8	1-1/4	3-1/2	5/8	.060	36384	36710	36815
5/8	1-1/4	3-1/2	5/8	.090	36385	36711	36816
5/8	1-1/4	3-1/2	5/8	.125	36733	36744	36817
3/4	1-1/2	4	3/4	.030	36386	36712	36818
3/4	1-1/2	4	3/4	.040	36862	36870	36808
3/4	1-1/2	4	3/4	.060	36387	36713	36819
3/4	1-1/2	4	3/4	.090	36388	36714	36820
3/4	1-1/2	4	3/4	.125	36389	36715	36821
1	1-1/2	4	1	.030	36390	36716	36822
1	1-1/2	4	1	.040	36863	36871	36809
1	1-1/2	4	1	.060	36391	36717	36823
1	1-1/2	4	1	.090	36392	36718	36824
1	1-1/2	4	1	.125	36393	36719	36825

TOLERANCES (inch)

<1/8 DIAMETER

DC = +0.0005/-0.0005

DCON = h₆

RE = +0.000/-0.0010

1/8-1/4 DIAMETER

DC = +0.000/-0.0012

DCON = h₆

RE = +0.000/-0.0020

>1/4-3/8 DIAMETER

DC = +0.000/-0.0016

DCON = h₆

RE = +0.000/-0.0020

>3/8-1 DIAMETER

DC = +0.000/-0.0020

DCON = h₆

RE = +0.000/-0.0020

STEELS

STAINLESS STEELS

CAST IRON

HIGH TEMP ALLOYS

TITANIUM

HARDENED STEELS

For patent information visit
www.ksptpatents.com

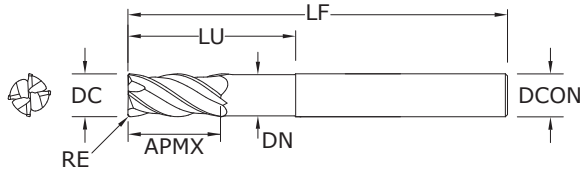

Z1PLC
FRACTIONAL SERIES

TOLERANCES (inch)

1/4 DIAMETER

DC = +0.0000/-0.0012

DCON = h_6

RE = +0.000/-0.005

>1/4-3/8 DIAMETER

DC = +0.0000/-0.0016

DCON = h_6

RE = +0.000/-0.005

>3/8-1 DIAMETER

DC = +0.0000/-0.0020

DCON = h_6

RE = +0.000/-0.005

STEELS

STAINLESS STEELS

CAST IRON

HIGH TEMP ALLOYS

TITANIUM

HARDENED STEELS

For patent information visit www.ksptpatents.com

CUTTING DIAMETER DC	LENGTH OF CUT APMX	OVERALL LENGTH LF	inch				CORNER RADIUS RE	EDP NO. Ti-NAMITE-X
			SHANK DIAMETER DCON	REACH LU	NECK DIAMETER DN			
1/4	1/2	2-1/2	1/4	1-1/8	.230	.020	36447	
1/4	1/2	3-1/2	1/4	1-5/8	.230	.020	36448	
1/4	1/2	4	1/4	1-1/4	.230	.020	36450	
1/4	1/2	4	1/4	2-1/8	.230	.020	36449	
5/16	13/16	3	5/16	1-3/8	.293	.020	36453	
5/16	13/16	4	5/16	2	.293	.020	36454	
5/16	13/16	4	5/16	1-5/8	.293	.020	36452	
3/8	7/8	3	3/8	1-5/8	.355	.020	36457	
3/8	7/8	5	3/8	1-7/8	.355	.020	36456	
3/8	7/8	4	3/8	2-3/8	.355	.020	36458	
7/16	1	6	7/16	2	.418	.020	36460	
1/2	1	4	1/2	2	.480	.030	36463	
1/2	1	5	1/2	3	.480	.030	36464	
1/2	1	6	1/2	2-1/4	.480	.030	36462	
9/16	1-1/8	6	9/16	2-1/2	.543	.030	36466	
5/8	1-1/4	5	5/8	2-1/2	.605	.040	36468	
5/8	1-1/4	6	5/8	3-3/4	.605	.040	36469	
5/8	1-1/4	6	5/8	3	.605	.040	36470	
3/4	1-1/2	6	3/4	3-1/2	.730	.040	36472	
1	1-1/2	6	1	3	.980	.040	36475	
1	1-1/2	6	1	4	.980	.040	36474	

- Variable rake geometry alters and controls the cutting dynamic taking chatter suppression to an unprecedented level
- Unequal helix design changes the cutting angle to improve harmonics
- Unequal flute spacing helps to disrupt the rhythmic pattern created by the cutting edge helping to suppress damaging harmonics
- Long reach design allows for deeper and faster cuts
- Enhanced corner geometry with tight tolerance corner radii
- Recommended for materials ≤ 45 HRc (≤ 420 Bhn)

FRACTIONAL Z-Carb-AP

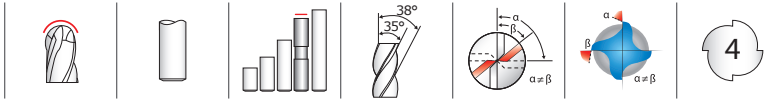

Z1PLB FRACTIONAL SERIES

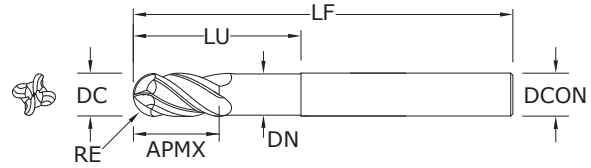

- Variable rake geometry alters and controls the cutting dynamic taking chatter suppression to an unprecedented level
- Unequal helix design changes the cutting angle to improve harmonics
- Long reach design allows for deeper and faster cuts
- Ball nose design ideal for finishing operations in complex workpieces
- Recommended for materials ≤ 45 HRc (≤ 420 Bhn)

CUTTING DIAMETER DC	LENGTH OF CUT APMX	inch				NECK DIAMETER DN	EDP NO. Ti-NAMITE-X
		OVERALL LENGTH LF	SHANK DIAMETER DCON	REACH LU			
1/4	1/2	4	1/4	1-1/4	.230	36480	
5/16	13/16	4	5/16	1-5/8	.293	36482	
3/8	7/8	5	3/8	1-7/8	.355	36486	
7/16	1	6	7/16	2	.418	38490	
1/2	1	6	1/2	2-1/4	.480	38492	
9/16	1-1/8	6	9/16	2-1/2	.543	38496	
5/8	1-1/4	6	5/8	3	.605	36500	
3/4	1-1/2	6	3/4	3-1/2	.730	36502	
1	1-1/2	6	1	4	.980	36504	

RE = 1/2 Cutting Diameter (DC)

TOLERANCES (inch)

1/4 DIAMETER

DC = +0.0000/-0.0012

DCON = h_6

RE = +0.0000/-0.0006

>1/4-3/8 DIAMETER

DC = +0.0000/-0.0016

DCON = h_6

RE = +0.0000/-0.0008

>3/8-1 DIAMETER

DC = +0.0000/-0.0020

DCON = h_6

RE = +0.0000/-0.0010

- STEELS
- STAINLESS STEELS
- CAST IRON
- HIGH TEMP ALLOYS
- TITANIUM
- HARDENED STEELS

For patent information visit www.ksptpatents.com

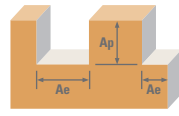

Series
Z1, Z16CR, Z1PCR,
Z1PLC, Z1PLB
Fractional

Series	Hardness	Ae x DC	Ap x DC	Vc (sfm)	DC • in										
					1/64	1/8	1/4	3/8	1/2	5/8	3/4	1			
P CARBON STEELS 1018, 1040, 1080, 1090, 10L50, 1140, 1212, 12L15, 1525, 1536	≤ 275 Bhn or ≤ 28 HRc	Profile 	≤ 0.5	≤ 1.5	555	RPM	135904	16961	8480	5654	4240	3392	2827	2120	
					(444-666)	Fz	0.00005	0.00046	0.0012	0.0023	0.0031	0.0034	0.0037	0.0043	
						Feed (ipm)	27.2	31.2	40.7	52.0	52.6	46.1	41.8	36.5	
		Slot 	1	≤ 1	440	RPM	107744	13446	6723	4482	3362	2689	2241	1681	
					(352-528)	Fz	0.00005	0.00046	0.0012	0.0023	0.0031	0.0034	0.0037	0.0043	
						Feed (ipm)	21.5	24.7	32.3	41.2	41.7	36.6	33.2	28.9	
	M ALLOY STEELS 4140, 4150, 4320, 5120, 5150, 8630, 86L20, 50100	≤ 375 Bhn or ≤ 40 HRc	Profile 	≤ 0.5	≤ 1.5	315	RPM	77135	9626	4813	3209	2407	1925	1604	1203
						(252-378)	Fz	0.00004	0.00034	0.0009	0.0017	0.0023	0.0026	0.0028	0.0032
							Feed (ipm)	12.3	13.1	17.3	21.8	22.1	20.0	18.0	15.4
			Slot 	1	≤ 1	250	RPM	61218	7640	3820	2547	1910	1528	1273	955
						(200-300)	Fz	0.00004	0.00034	0.0009	0.0017	0.0023	0.0026	0.0028	0.0032
							Feed (ipm)	9.8	10.4	13.8	17.3	17.6	15.9	14.3	12.2
K STAINLESS STEELS (FREE MACHINING) 303, 416, 420F, 430F, 440F		≤ 275 Bhn or ≤ 28 HRc	Profile 	≤ 0.5	≤ 1.5	490	RPM	119987	14974	7487	4991	3744	2995	2496	1872
						(392-588)	Fz	0.00004	0.00034	0.0009	0.0017	0.0023	0.0026	0.0028	0.0032
							Feed (ipm)	19.2	20.4	27.0	33.9	34.4	31.1	28.0	24.0
			Slot 	1	≤ 1	390	RPM	95500	11918	5959	3973	2980	2384	1986	1490
						(312-468)	Fz	0.00004	0.00034	0.0009	0.0017	0.0023	0.0026	0.0028	0.0032
							Feed (ipm)	15.3	16.2	21.5	27.0	27.4	24.8	22.2	19.1
	M STAINLESS STEELS (DIFFICULT) 304, 304L, 316, 316L	≤ 275 Bhn or ≤ 28 HRc	Profile 	≤ 0.5	≤ 1.5	340	RPM	83256	10390	5195	3463	2598	2078	1732	1299
						(272-408)	Fz	0.00003	0.00027	0.0007	0.0014	0.0018	0.0020	0.0022	0.0025
							Feed (ipm)	10.0	11.2	14.5	19.4	18.7	16.6	15.2	13.0
			Slot 	1	≤ 1	270	RPM	66115	8251	4126	2750	2063	1650	1375	1031
						(216-324)	Fz	0.00003	0.00027	0.0007	0.0014	0.0018	0.0020	0.0022	0.0025
							Feed (ipm)	7.9	8.9	11.6	15.4	14.9	13.2	12.1	10.3
K STAINLESS STEELS (PH) 13-8 PH, 15-5 PH, 17-4 PH, Custom 450		≤ 325 Bhn or ≤ 35 HRc	Profile 	≤ 0.5	≤ 1.5	310	RPM	75910	9474	4737	3158	2368	1895	1579	1184
						(248-372)	Fz	0.00003	0.00027	0.0007	0.0014	0.0018	0.0020	0.0022	0.0025
							Feed (ipm)	9.1	10.2	13.3	17.7	17.1	15.2	13.9	11.8
			Slot 	1	≤ 1	250	RPM	61218	7640	3820	2547	1910	1528	1273	955
						(200-300)	Fz	0.00003	0.00027	0.0007	0.0014	0.0018	0.0020	0.0022	0.0025
							Feed (ipm)	7.3	8.3	10.7	14.3	13.8	12.2	11.2	9.6
	K CAST IRONS (LOW & MEDIUM ALLOY) Gray, Malleable, Ductile	≤ 220 Bhn or ≤ 19 HRc	Profile 	≤ 0.5	≤ 1.5	445	RPM	108968	13599	6800	4533	3400	2720	2267	1700
						(356-534)	Fz	0.00005	0.00042	0.0011	0.0021	0.0028	0.0031	0.0034	0.0039
							Feed (ipm)	21.8	22.8	29.9	38.1	38.1	33.7	30.8	26.5
			Slot 	1	≤ 1	355	RPM	86929	10849	5424	3616	2712	2170	1808	1356
						(284-426)	Fz	0.00005	0.00042	0.0011	0.0021	0.0028	0.0031	0.0034	0.0039
							Feed (ipm)	17.4	18.2	23.9	30.4	30.4	26.9	24.6	21.2

continued on next page

FRACTIONAL Z-Carb-AP

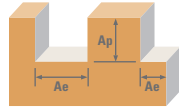

Series
Z1, Z16CR, Z1PCR,
Z1PLC, Z1PLB
Fractional

	Hardness	Ae x DC	Ap x DC	Vc (sfm)	DC • in								
					1/64	1/8	1/4	3/8	1/2	5/8	3/4	1	
K	CAST IRONS (HIGH ALLOY) Gray, Malleable, Ductile ≤ 260 Bhn or ≤ 26 HRC	Profile ≤ 0.5	≤ 1.5	340	RPM	83256	10390	5195	3463	2598	2078	1732	1299
				(272-408)	Fz	0.00004	0.00031	0.0008	0.0016	0.0021	0.0023	0.0025	0.0029
				Feed (ipm)	13.3	12.9	17.5	22.2	21.8	19.1	17.3	15.1	
		Slot 1	≤ 1	270	RPM	66115	8251	4126	2750	2063	1650	1375	1031
				(216-324)	Fz	0.00004	0.00031	0.0008	0.0016	0.0021	0.0023	0.0025	0.0029
				Feed (ipm)	10.6	10.2	13.9	17.6	17.3	15.2	13.8	12.0	
S	SUPER ALLOYS (NICKEL, COBALT, IRON BASE) Inconel 601, 617, 625, Incoloy, Monel 400 ≤ 300 Bhn or ≤ 32 HRC	Profile ≤ 0.5	≤ 1.5	80	RPM	19590	2445	1222	815	611	489	407	306
				(64-96)	Fz	0.00003	0.00025	0.0007	0.0013	0.0017	0.0019	0.0020	0.0024
				Feed (ipm)	2.4	2.4	3.3	4.2	4.2	3.7	3.3	2.9	
		Slot 1	≤ 1	65	RPM	15917	1986	993	662	497	397	331	248
				(52-78)	Fz	0.00003	0.00025	0.0007	0.0013	0.0017	0.0019	0.0020	0.0024
				Feed (ipm)	1.9	2.0	2.7	3.4	3.4	3.0	2.7	2.4	
S	SUPER ALLOYS (NICKEL, COBALT, IRON BASE) Inconel 718, X-750, Incoloy, Waspaloy, Hastelloy, Rene ≤ 400 Bhn or ≤ 43 HRC	Profile ≤ 0.5	≤ 1.5	62	RPM	15182	1895	947	632	474	379	316	237
				(50-74)	Fz	0.00002	0.00018	0.0005	0.0009	0.0012	0.0013	0.0014	0.0017
				Feed (ipm)	1.2	1.4	1.8	2.3	2.3	2.0	1.8	1.6	
		Slot 1	≤ 1	50	RPM	12244	1528	764	509	382	306	255	191
				(40-60)	Fz	0.00002	0.00018	0.0005	0.0009	0.0012	0.0013	0.0014	0.0017
				Feed (ipm)	1.0	1.1	1.5	1.8	1.8	1.6	1.4	1.3	
S	TITANIUM ALLOYS Pure Titanium, Ti6Al4V, Ti6Al2Sn4Zr2Mo, Ti4Al4Mo2Sn0.5Si ≤ 350 Bhn or ≤ 38 HRC	Profile ≤ 0.5	≤ 1.5	215	RPM	52647	6570	3285	2190	1643	1314	1095	821
				(172-258)	Fz	0.00003	0.0003	0.0008	0.0015	0.0020	0.0022	0.0024	0.0028
				Feed (ipm)	6.3	7.9	10.5	13.1	13.1	11.6	10.5	9.2	
		Slot 1	≤ 1	170	RPM	41628	5195	2598	1732	1299	1039	866	649
				(136-204)	Fz	0.00003	0.0003	0.0008	0.0015	0.0020	0.0022	0.0024	0.0028
				Feed (ipm)	5.0	6.2	8.3	10.4	10.4	9.1	8.3	7.3	
S	TITANIUM ALLOYS (DIFFICULT) Ti10Al2Fe3Al, Ti5Al5V5Mo3Cr, Ti7Al4Mo, Ti3Al8V6Cr4Zr4Mo, Ti6Al6V6Sn, Ti15V3 Cr3Sn3Al ≤ 440 Bhn or ≤ 47 HRC	Profile ≤ 0.5	≤ 1.5	75	RPM	18365	2292	1146	764	573	458	382	287
				(60-90)	Fz	0.00003	0.0003	0.0008	0.0015	0.0020	0.0022	0.0024	0.0028
				Feed (ipm)	2.2	2.8	3.7	4.6	4.6	4.0	3.7	3.2	
		Slot 1	≤ 1	60	RPM	14692	1834	917	611	458	367	306	229
				(48-72)	Fz	0.00003	0.0003	0.0008	0.0015	0.0020	0.0022	0.0024	0.0028
				Feed (ipm)	1.8	2.2	2.9	3.7	3.7	3.2	2.9	2.6	
H	TOOL STEELS A2, D2, H13, L2, M2, P20, S7, T15, W2 ≤ 375 Bhn or ≤ 40 HRC	Profile ≤ 0.5	≤ 1.5	185	RPM	45301	5654	2827	1885	1413	1131	942	707
				(148-222)	Fz	0.00003	0.00028	0.0007	0.0014	0.0018	0.0020	0.0022	0.0026
				Feed (ipm)	5.4	6.3	7.9	10.6	10.2	9.0	8.3	7.3	
		Slot 1	≤ 1	145	RPM	35506	4431	2216	1477	1108	886	739	554
				(116-174)	Fz	0.00003	0.00028	0.0007	0.0014	0.0018	0.0020	0.0022	0.0026
				Feed (ipm)	4.3	5.0	6.2	8.3	8.0	7.1	6.5	5.8	

Bhn (Brinell) HRC (Rockwell C)

rpm = Vc x 3.82 / DC

ipm = Fz x 4 x rpm

maximum Slotting Ap for Z1PCR <1/8 diameter and all Z1PLC / Z1PLB is .25 x DC

maximum Profile Ae for Z1PCR <1/8 diameter and all Z1PLC / Z1PLB is .20 x DC

reduce speed and feed for materials harder than listed

reduce feed and Ae when finish milling (.02 x DC maximum)

feed rates listed have chip thinning adjustments included where applicable

refer to the SGS Tool Wizard® for complete technical information (www.kyocera-sgstool.com)

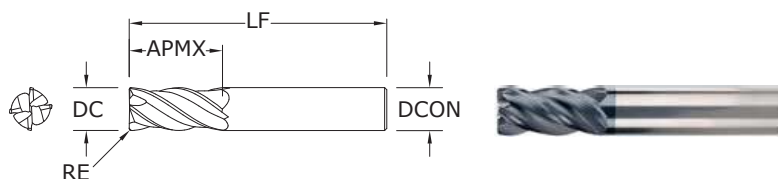
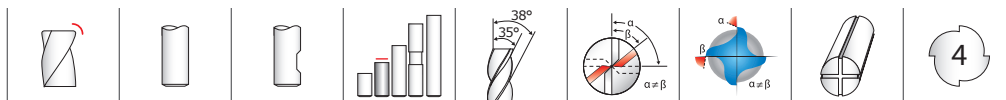

Z1MPCR
METRIC SERIES

TOLERANCES (mm)

<3 DIAMETER

DC = +0,012/-0,012

DCON = h₆

RE = +0,000/-0,025

3-6 DIAMETER

DC = +0,000/-0,030

DCON = h₆

RE = +0,000/-0,050

>6-10 DIAMETER

DC = +0,000/-0,040

DCON = h₆

RE = +0,000/-0,050

>10-25 DIAMETER

DC = +0,000/-0,050

DCON = h₆

RE = +0,000/-0,050

STEELS

STAINLESS STEELS

CAST IRON

HIGH TEMP ALLOYS

TITANIUM

For patent information visit www.ksptpatents.com

CUTTING DIAMETER DC	LENGTH OF CUT APMX	mm			EDP NO.		
		OVERALL LENGTH LF	SHANK DIAMETER DCON	CORNER RADIUS RE	Ti-NAMITE-X	Ti-NAMITE-X W/FLAT	JetStream
1,0	3,0	57,0	6,0	0,1	46873*	—	—
1,5	4,5	57,0	6,0	0,1	46849*	—	—
2,0	6,0	57,0	6,0	0,2	46850*	—	—
2,5	7,0	57,0	6,0	0,2	46874*	—	—
3,0	8,0	57,0	6,0	0,3	46851	—	—
3,0	8,0	57,0	6,0	0,5	46880	—	—
4,0	11,0	57,0	6,0	0,3	46852	—	—
4,0	11,0	57,0	6,0	0,5	46881	—	—
5,0	13,0	57,0	6,0	0,3	46853	—	—
6,0	13,0	57,0	6,0	0,25	46882	—	—
6,0	13,0	57,0	6,0	0,5	46854	—	—
6,0	13,0	57,0	6,0	1,0	46855	—	—
6,0	13,0	57,0	6,0	1,5	46884	—	—
8,0	19,0	63,0	8,0	0,5	46856	—	—
8,0	19,0	63,0	8,0	1,0	46857	—	—
8,0	19,0	63,0	8,0	1,5	46886	—	—
8,0	19,0	63,0	8,0	2,0	46887	—	—
10,0	22,0	72,0	10,0	0,5	46858	—	—
10,0	22,0	72,0	10,0	1,0	46859	—	—
10,0	22,0	72,0	10,0	1,5	46889	—	—
10,0	22,0	72,0	10,0	2,0	46890	—	—
10,0	22,0	72,0	10,0	2,5	46891	—	—
12,0	26,0	83,0	12,0	0,5	46860	46909	—
12,0	26,0	83,0	12,0	0,75	46861	46910	46493
12,0	26,0	83,0	12,0	1,0	46893	46911	—
12,0	26,0	83,0	12,0	1,5	46894	46912	—
12,0	26,0	83,0	12,0	2,0	46895	46913	—
12,0	26,0	83,0	12,0	2,5	46896	46914	—
12,0	26,0	83,0	12,0	3,0	42718	46915	42719
14,0	26,0	83,0	14,0	1,0	46862	46916	46494
16,0	32,0	92,0	16,0	1,0	46863	46917	46495
16,0	32,0	92,0	16,0	1,5	46898	46918	—
16,0	32,0	92,0	16,0	2,0	46899	46919	—
16,0	32,0	92,0	16,0	2,5	46900	46920	—
16,0	32,0	92,0	16,0	3,0	46864	46921	42721
16,0	32,0	92,0	16,0	4,0	46867	46944	—
20,0	38,0	104,0	20,0	1,0	46865	46922	46497
20,0	38,0	104,0	20,0	1,5	46903	46923	—
20,0	38,0	104,0	20,0	2,0	46904	46924	—
20,0	38,0	104,0	20,0	2,5	46905	46925	—
20,0	38,0	104,0	20,0	3,0	42722	46926	42723
20,0	38,0	104,0	20,0	4,0	46868	46945	—
20,0	38,0	104,0	20,0	5,0	46869	46946	—
25,0	38,0	104,0	25,0	1,0	46866	46927	46498

*Variable flute spacing. Helix and rake do not vary.

- Variable rake geometry alters and controls the cutting dynamic taking chatter suppression to an unprecedented level
- Unequal helix design changes the cutting angle to improve harmonics
- Unequal flute spacing helps to disrupt the rhythmic pattern created by the cutting edge helping to suppress damaging harmonics
- Enhanced corner geometry with tight tolerance corner radii
- Recommended for materials ≤ 45 HRC (≤ 420 Bhn)

METRIC Z-Carb-AP

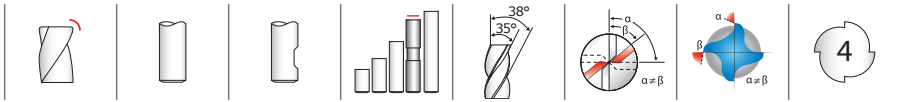

Z1MPIC • Z1MPLC METRIC SERIES

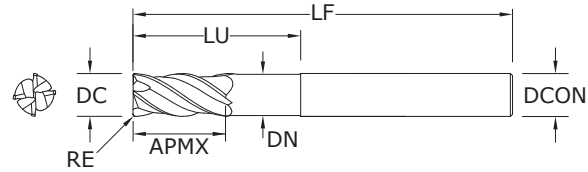

- Variable rake geometry alters and controls the cutting dynamic taking chatter suppression to an unprecedented level
- Unequal helix design changes the cutting angle to improve harmonics
- Unequal flute spacing helps to disrupt the rhythmic pattern created by the cutting edge helping to suppress damaging harmonics
- Long reach design allows for deeper and faster cuts
- Enhanced corner geometry with tight tolerance corner radii
- Recommended for materials ≤ 45 HRc (≤ 420 Bhn)

CUTTING DIAMETER DC	LENGTH OF CUT APMX	OVERALL LENGTH LF	mm				EDP NO.	
			SHANK DIAMETER DCON	REACH LU	NECK DIAMETER DN	CORNER RADIUS RE	Ti-NAMITE-X	Ti-NAMITE-X W/FLAT
6,0	8,0	75,0	6,0	24,0	5,49	0,5	46821	—
8,0	10,0	75,0	8,0	32,0	7,49	1,0	46822	—
8,0	10,0	75,0	8,0	32,0	7,49	2,0	46823	—
10,0	12,0	100,0	10,0	40,0	9,50	1,0	46824	—
10,0	12,0	100,0	10,0	40,0	9,50	2,0	46825	—
12,0	15,0	100,0	12,0	48,0	11,48	1,0	46826	46928
12,0	15,0	100,0	12,0	48,0	11,48	1,5	46827	46929
12,0	15,0	100,0	12,0	48,0	11,48	2,0	46828	46930
12,0	15,0	100,0	12,0	48,0	11,48	3,0	46829	46931
12,0	26,0	83,0	12,0	36,0	11,48	2,5	—	42731
12,0	26,0	83,0	12,0	36,0	11,48	3,0	—	42732
12,0	26,0	83,0	12,0	36,0	11,48	4,0	—	42733
16,0	32,0	92,0	16,0	42,0	15,49	2,5	—	42734
16,0	32,0	92,0	16,0	42,0	15,49	4,0	—	42735
16,0	32,0	92,0	16,0	42,0	15,49	6,0	—	42736
16,0	20,0	115,0	16,0	65,0	15,49	1,0	46830	46932
16,0	20,0	115,0	16,0	65,0	15,49	1,5	46831	46933
16,0	20,0	115,0	16,0	65,0	15,49	2,0	46832	46934
16,0	20,0	115,0	16,0	65,0	15,49	3,0	46833	46935
16,0	20,0	115,0	16,0	65,0	15,49	4,0	46834	46936
16,0	20,0	115,0	16,0	65,0	15,49	5,0	46835	46937
20,0	24,0	140,0	20,0	80,0	19,48	1,0	46836	46938
20,0	24,0	140,0	20,0	80,0	19,48	1,5	46837	46939
20,0	24,0	140,0	20,0	80,0	19,48	2,0	46838	46940
20,0	24,0	140,0	20,0	80,0	19,48	3,0	46839	46941
20,0	24,0	140,0	20,0	80,0	19,48	4,0	46840	46942
20,0	24,0	140,0	20,0	80,0	19,48	5,0	46841	46943
20,0	38,0	104,0	20,0	52,0	19,48	2,5	—	42737
20,0	38,0	104,0	20,0	52,0	19,48	4,0	—	42738
20,0	38,0	104,0	20,0	52,0	19,48	6,0	—	42739

TOLERANCES (mm)

- 6 DIAMETER**
 DC = $+0,000/-0,030$
 DCON = h_6
 RE = $+0,000/-0,050$
- >6-10 DIAMETER**
 DC = $+0,000/-0,040$
 DCON = h_6
 RE = $+0,000/-0,050$
- >10-20 DIAMETER**
 DC = $+0,000/-0,050$
 DCON = h_6
 RE = $+0,000/-0,050$

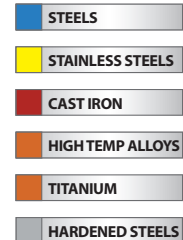

For patent information visit www.ksptpatents.com

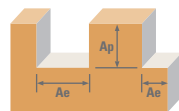

Series Z1M, Z1MPCR, Z1MPIC, Z1MPLC Metric	Hardness	Ae x DC	Ap x DC	Vc (m/min)	DC • mm										
					1	3	6	8	10	12	16	20	25		
P CARBON STEELS 1018, 1040, 1080, 1090, 10L50, 1140, 1212, 12L15, 1525, 1536	≤ 275 Bhn or ≤ 28 HRc	Profile 	≤ 0.5	≤ 1.5	169	RPM	53803	17934	8967	6725	5380	4484	3363	2690	2152
					(135-203)	Fz	0.0030	0.0109	0.029	0.049	0.061	0.074	0.087	0.099	0.108
					Feed (mm/min)	646	782	1040	1318	1313	1327	1170	1065	930	
		Slot 	1	≤ 1	134	RPM	42654	14218	7109	5332	4265	3555	2666	2133	1706
					(107-161)	Fz	0.0030	0.0109	0.029	0.049	0.061	0.074	0.087	0.099	0.108
					Feed (mm/min)	512	620	825	1045	1041	1052	928	845	737	
	≤ 375 Bhn or ≤ 40 HRc	Profile 	≤ 0.5	≤ 1.5	96	RPM	30537	10179	5089	3817	3054	2545	1909	1527	1221
					(77-115)	Fz	0.0023	0.0081	0.022	0.036	0.045	0.055	0.067	0.075	0.080
					Feed (mm/min)	281	330	448	550	550	560	511	458	391	
		Slot 	1	≤ 1	76	RPM	24235	8078	4039	3029	2424	2020	1515	1212	969
					(61-91)	Fz	0.0023	0.0081	0.022	0.036	0.045	0.055	0.067	0.075	0.080
					Feed (mm/min)	223	262	355	436	436	444	406	364	310	
M STAINLESS STEELS (FREE MACHINING) 303, 416, 420F, 430F, 440F	≤ 275 Bhn or ≤ 28 HRc	Profile 	≤ 0.5	≤ 1.5	149	RPM	47501	15834	7917	5938	4750	3958	2969	2375	1900
					(119-179)	Fz	0.0023	0.0081	0.022	0.036	0.045	0.055	0.067	0.075	0.080
					Feed (mm/min)	437	513	697	855	855	871	796	713	608	
		Slot 	1	≤ 1	119	RPM	37807	12602	6301	4726	3781	3151	2363	1890	1512
					(95-143)	Fz	0.0023	0.0081	0.022	0.036	0.045	0.055	0.067	0.075	0.080
					Feed (mm/min)	348	408	555	681	681	693	633	567	484	
	≤ 275 Bhn or ≤ 28 HRc	Profile 	≤ 0.5	≤ 1.5	104	RPM	32960	10987	5493	4120	3296	2747	2060	1648	1318
					(83-124)	Fz	0.0018	0.0064	0.017	0.030	0.037	0.043	0.051	0.059	0.063
					Feed (mm/min)	237	281	374	494	488	472	420	389	332	
		Slot 	1	≤ 1	82	RPM	26174	8725	4362	3272	2617	2181	1636	1309	1047
					(66-99)	Fz	0.0018	0.0064	0.017	0.030	0.037	0.043	0.051	0.059	0.063
					Feed (mm/min)	188	223	297	393	387	375	334	309	264	
≤ 325 Bhn or ≤ 35 HRc	Profile 	≤ 0.5	≤ 1.5	94	RPM	30052	10017	5009	3756	3005	2504	1878	1503	1202	
				(76-113)	Fz	0.0018	0.0064	0.017	0.030	0.037	0.043	0.051	0.059	0.063	
				Feed (mm/min)	216	256	341	451	445	431	383	355	303		
	Slot 	1	≤ 1	76	RPM	24235	8078	4039	3029	2424	2020	1515	1212	969	
				(61-91)	Fz	0.0018	0.0064	0.017	0.030	0.037	0.043	0.051	0.059	0.063	
				Feed (mm/min)	174	207	275	364	359	347	309	286	244		
K CAST IRONS (LOW & MEDIUM ALLOY) Gray, Malleable, Ductile	≤ 220 Bhn or ≤ 19 HRc	Profile 	≤ 0.5	≤ 1.5	136	RPM	43139	14380	7190	5392	4314	3595	2696	2157	1726
					(109-163)	Fz	0.0028	0.0099	0.026	0.045	0.056	0.067	0.079	0.091	0.098
					Feed (mm/min)	483	569	748	971	966	963	852	785	676	
		Slot 	1	≤ 1	108	RPM	34414	11471	5736	4302	3441	2868	2151	1721	1377
					(87-130)	Fz	0.0028	0.0099	0.026	0.045	0.056	0.067	0.079	0.091	0.098
					Feed (mm/min)	385	454	597	774	771	769	680	626	540	

continued on next page

Z-Carb-AP

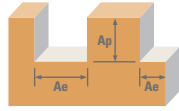

Series
Z1M, Z1MPCR,
Z1MPLC, Z1MPLB
Metric

K	Hardness	Ae x DC	Ap x DC	Vc (m/min)	DC • mm													
					1	3	6	8	10	12	16	20	25					
CAST IRONS (HIGH ALLOY) Gray, Malleable, Ductile	≤ 260 Bhn or ≤ 26 HRc	≤ 0.5	≤ 1.5	104 (83-124)	RPM	32960	10987	5493	4120	3296	2747	2060	1648	1318				
					Fz	0.0020	0.0074	0.020	0.034	0.043	0.050	0.059	0.067	0.074				
					Feed (mm/min)	264	325	439	560	567	549	486	442	390				
					Slot	1	≤ 1	82 (66-99)	RPM	26174	8725	4362	3272	2617	2181	1636	1309	1047
									Fz	0.0020	0.0074	0.020	0.034	0.043	0.050	0.059	0.067	0.074
									Feed (mm/min)	209	258	349	445	450	436	386	351	310
SUPER ALLOYS (NICKEL, COBALT, IRON BASE) Inconel 601, 617, 625, Incoloy, Monel 400	≤ 300 Bhn or ≤ 32 HRc	≤ 0.5	≤ 1.5	24 (20-29)	RPM	7755	2585	1293	969	776	646	485	388	310				
					Fz	0.0018	0.0061	0.016	0.027	0.034	0.041	0.048	0.053	0.060				
					Feed (mm/min)	56	63	83	105	105	106	93	82	74				
					Slot	1	≤ 1	20 (16-24)	RPM	6301	2100	1050	788	630	525	394	315	252
									Fz	0.0018	0.0061	0.016	0.027	0.034	0.041	0.048	0.053	0.060
									Feed (mm/min)	45	51	67	85	86	86	76	67	60
SUPER ALLOYS (NICKEL, COBALT, IRON BASE) Inconel 718, X-750, Incoloy, Waspaloy, Hastelloy, Rene	≤ 400 Bhn or ≤ 43 HRc	≤ 0.5	≤ 1.5	19 (15-23)	RPM	6010	2003	1002	751	601	501	376	301	240				
					Fz	0.0013	0.0043	0.011	0.019	0.024	0.028	0.033	0.037	0.042				
					Feed (mm/min)	31	34	44	57	58	56	50	44	40				
					Slot	1	≤ 1	15 (12-18)	RPM	4847	1616	808	606	485	404	303	242	194
									Fz	0.0013	0.0043	0.011	0.019	0.024	0.028	0.033	0.037	0.042
									Feed (mm/min)	25	28	36	46	47	45	40	36	33
TITANIUM ALLOYS Pure Titanium, Ti6Al4V, Ti6Al2Sn4Zr2Mo, Ti4Al4Mo2Sn0.5Si	≤ 350 Bhn or ≤ 38 HRc	≤ 0.5	≤ 1.5	66 (52-79)	RPM	20842	6947	3474	2605	2084	1737	1303	1042	834				
					Fz	0.0020	0.0071	0.019	0.032	0.040	0.048	0.056	0.064	0.070				
					Feed (mm/min)	167	197	264	333	333	333	292	267	233				
					Slot	1	≤ 1	52 (41-62)	RPM	16480	5493	2747	2060	1648	1373	1030	824	659
									Fz	0.0020	0.0071	0.019	0.032	0.040	0.048	0.056	0.064	0.070
									Feed (mm/min)	132	156	209	264	264	264	231	211	185
TITANIUM ALLOYS (DIFFICULT) Ti10Al2Fe3Al, Ti5Al5V5Mo3Cr, Ti7Al4Mo, Ti3Al8V6Cr4Zr4Mo, Ti6Al6V6Sn, Ti15V3 Cr3Sn3Al	≤ 440 Bhn or ≤ 47 HRc	≤ 0.5	≤ 1.5	23 (18-27)	RPM	7271	2424	1212	909	727	606	454	364	291				
					Fz	0.0020	0.0071	0.019	0.032	0.040	0.048	0.056	0.064	0.070				
					Feed (mm/min)	58	69	92	116	116	116	102	93	81				
					Slot	1	≤ 1	18 (15-22)	RPM	5816	1939	969	727	582	485	364	291	233
									Fz	0.0020	0.0071	0.019	0.032	0.040	0.048	0.056	0.064	0.070
									Feed (mm/min)	47	55	74	93	93	93	81	74	65
TOOL STEELS A2, D2, H13, L2, M2, P20, S7, T15, W2	≤ 375 Bhn or ≤ 40 HRc	≤ 0.5	≤ 1.5	56 (45-68)	RPM	17934	5978	2989	2242	1793	1495	1121	897	717				
					Fz	0.0018	0.0066	0.017	0.030	0.037	0.043	0.051	0.059	0.065				
					Feed (mm/min)	129	158	203	269	265	257	229	212	187				
					Slot	1	≤ 1	44 (35-53)	RPM	14057	4686	2343	1757	1406	1171	879	703	562
									Fz	0.0018	0.0066	0.017	0.030	0.037	0.043	0.051	0.059	0.065
									Feed (mm/min)	101	124	159	211	208	201	179	166	146

Bhn (Brinell) HRc (Rockwell C)

$$\text{rpm} = (\text{Vc} \times 1000) / (\text{DC} \times 3.14)$$

$$\text{mm/min} = \text{Fz} \times 4 \times \text{rpm}$$

maximum Slotting Ap for Z1PCR <3mm diameter and all Z1MPLC / Z1MPLB is .25 x DC

maximum Profile Ae for Z1PCR <3mm diameter and all Z1MPLC / Z1MPLB is .20 x DC

reduce speed and feed for materials harder than listed

reduce feed and Ae when finish milling (.02 x DC maximum)

feed rates listed have chip thinning adjustments included where applicable

refer to the SGS Tool Wizard® for complete technical information (www.kyocera-sgstool.com)

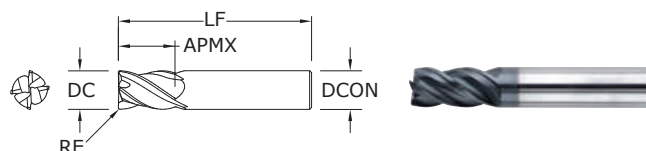

Z1 • Z16CR FRACTIONAL SERIES

TOLERANCES (inch)

1/8–1/4 DIAMETER

DC = +0.0000/–0.0012

DCON = h_6

RE = +0.000/–0.002

>1/4–3/8 DIAMETER

DC = +0.0000/–0.0016

DCON = h_6

RE = +0.000/–0.002

>3/8–3/4 DIAMETER

DC = +0.0000/–0.0020

DCON = h_6

RE = +0.000/–0.002

STEELS

STAINLESS STEELS

CAST IRON

HIGH TEMP ALLOYS

TITANIUM

HARDENED STEELS

For patent
information visit
www.ksptpatents.com

CUTTING DIAMETER DC	LENGTH OF CUT APMX	inch			EDP NO.		
		OVERALL LENGTH LF	SHANK DIAMETER DCON	CORNER RADIUS RE	Ti-NAMITE-X	Ti-NAMITE-X W/FLAT	JetStream
1/8	1/4	1-1/2	1/8	.015	36505	–	–
1/8	3/8	1-1/2	1/8	–	36404	–	–
5/32	5/16	2	3/16	.015	36506	–	–
5/32	7/16	2	3/16	–	36406	–	–
3/16	3/8	2	3/16	.015	36507	–	–
3/16	7/16	2	3/16	–	36408	–	–
7/32	3/8	2	1/4	.020	36508	–	–
1/4	1/2	2-1/2	1/4	–	36416	–	–
1/4	7/16	2	1/4	.020	36509	–	–
1/4	3/4	2-1/2	1/4	–	36596	–	–
9/32	5/8	2-1/2	5/16	–	36418	–	–
5/16	1/2	2	5/16	.020	36511	–	–
5/16	13/16	2-1/2	5/16	–	36420	–	–
11/32	13/16	2-1/2	3/8	–	36422	–	–
3/8	5/8	2	3/8	.020	36513	–	–
3/8	7/8	2-1/2	3/8	–	36424	36530	–
13/32	15/16	2-3/4	7/16	–	36426	36531	–
7/16	5/8	2-1/2	7/16	.020	36515	–	–
7/16	1	2-3/4	7/16	–	36428	36532	–
15/32	1	3	1/2	–	36430	36533	–
1/2	5/8	2-1/2	1/2	.030	36517	–	–
1/2	1	3	1/2	–	36432	36534	36826
1/2	1-1/4	3-1/4	1/2	–	36597	36598	–
9/16	1-1/8	3-1/2	9/16	–	36436	36535	36827
5/8	3/4	3	5/8	.040	36519	–	–
5/8	1-1/4	3-1/2	5/8	–	36440	36536	36828
3/4	1	3	3/4	.040	36520	–	–
3/4	1-1/2	4	3/4	–	36442	36537	36829
1	1-1/2	4	1	–	36444	36538	36830

Refer to page 43 for speed & feed recommendations

- Variable rake geometry alters and controls the cutting dynamic taking chatter suppression to an unprecedented level
- Unequal helix design reduces damaging harmonics by changing the angle at which each cutting edge enters and exits the material
- Unequal flute spacing helps to disrupt the rhythmic pattern created by the cutting edge helping to suppress damaging harmonics
- Optimal material removal rates through increased feed and depths of cut
- Enhanced corner geometry with tight tolerance corner radii
- Recommended for materials ≤ 45 HRc (≤ 420 Bhn)

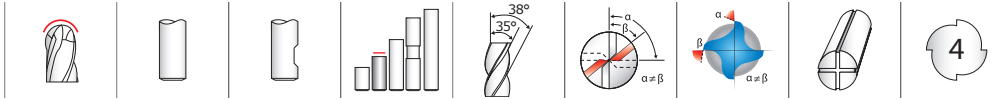

Z1B FRACTIONAL SERIES

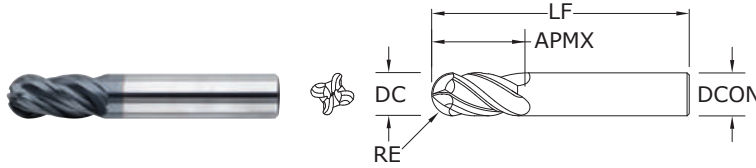

- Unequal helix design reduces damaging harmonics by changing the angle at which each cutting edge enters and exits the material
- Unequal flute spacing helps to disrupt the rhythmic pattern created by the cutting edge helping to suppress damaging harmonics
- Optimal material removal rates through increased feed and depths of cut
- Ball nose design ideal for finishing operations in complex workpieces
- Recommended for materials ≤ 45 HRc (≤ 420 Bhn)

CUTTING DIAMETER DC	inch			EDP NO.		
	LENGTH OF CUT APMX	OVERALL LENGTH LF	SHANK DIAMETER DCON	Ti-NAMITE-X (TX)	Ti-NAMITE-X (TX) W/FLAT	JetStream
1/8	3/8	1-1/2	1/8	36358	—	—
5/32	7/16	2	3/16	36357	—	—
3/16	7/16	2	3/16	36359	—	—
7/32	7/16	2-1/2	1/4	36361	—	—
1/4	1/2	2-1/2	1/4	36344	—	—
1/4	3/4	2-1/2	1/4	36590	—	—
9/32	5/8	2-1/2	5/16	36353	—	—
5/16	13/16	2-1/2	5/16	36345	—	—
11/32	13/16	2-1/2	3/8	36354	—	—
3/8	7/8	2-1/2	3/8	36346	36539	—
13/32	15/16	2-3/4	7/16	36355	36540	—
7/16	1	2-3/4	7/16	36347	36541	—
15/32	1	3	1/2	36356	36542	—
1/2	1	3	1/2	36348	36543	36846
1/2	1-1/4	3-1/4	1/2	36591	36592	—
9/16	1-1/8	3-1/2	9/16	36349	36544	36847
5/8	1-1/4	3-1/2	5/8	36350	36545	36848
3/4	1-1/2	4	3/4	36351	36546	36849
1	1-1/2	4	1	36352	36547	36850

RE = 1/2 Cutting Diameter (DC)

TOLERANCES (inch)

- 1/8–1/4 DIAMETER**
 DC = +0.0000/–0.0012
 DCON = h_6
 RE = +0.0000/–0.0006
- >1/4–3/8 DIAMETER**
 DC = +0.0000/–0.0016
 DCON = h_6
 RE = +0.0000/–0.0008
- >3/8–1 DIAMETER**
 DC = +0.0000/–0.0020
 DCON = h_6
 RE = +0.0000/–0.0010

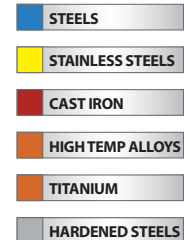

For patent information visit www.ksptpatents.com

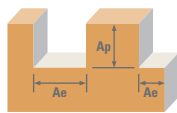





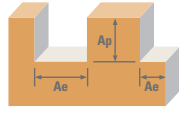

Series Z1B Fractional	Hardness	Ae x DC	Ap x DC	Vc (sfm)	DC • in									
					1/8	1/4	3/8	1/2	5/8	3/4	1			
P CARBON STEELS 1018, 1040, 1080, 1090, 10L50, 1140, 1212, 12L15, 1525, 1536	≤ 275 Bhn or ≤ 28 HRc	Profile 	≤ 0.5	≤ 1.5	555	RPM	16961	8480	5654	4240	3392	2827	2120	
					(444-666)	Fz	0.0004	0.0010	0.0019	0.0025	0.0031	0.0032	0.0035	
						Feed (ipm)	25.8	33.9	43.0	42.4	42.1	36.5	29.7	
		Slot 	1	≤ 1	440	RPM	13446	6723	4482	3362	2689	2241	1681	
					(352-528)	Fz	0.0004	0.0010	0.0019	0.0025	0.0031	0.0032	0.0035	
						Feed (ipm)	20.4	26.9	34.1	33.6	33.3	29.0	23.5	
	M ALLOY STEELS 4140, 4150, 4320, 5120, 5150, 8630, 86L20, 50100	≤ 375 Bhn or ≤ 40 HRc	Profile 	≤ 0.5	≤ 1.5	315	RPM	9626	4813	3209	2407	1925	1604	1203
						(252-378)	Fz	0.0003	0.0008	0.0014	0.0019	0.0024	0.0025	0.0027
							Feed (ipm)	10.8	15.4	18.0	18.3	18.5	16.0	13.0
			Slot 	1	≤ 1	250	RPM	7640	3820	2547	1910	1528	1273	955
						(200-300)	Fz	0.0003	0.0008	0.0014	0.0019	0.0024	0.0025	0.0027
							Feed (ipm)	8.6	12.2	14.3	14.5	14.7	12.7	10.3
K STAINLESS STEELS (FREE MACHINING) 303, 416, 420F, 430F, 440F		≤ 275 Bhn or ≤ 28 HRc	Profile 	≤ 0.5	≤ 1.5	490	RPM	14974	7487	4991	3744	2995	2496	1872
						(392-588)	Fz	0.0003	0.0007	0.0014	0.0018	0.0023	0.0024	0.0025
							Feed (ipm)	18.0	21.0	28.0	27.0	27.6	24.0	18.7
			Slot 	1	≤ 1	390	RPM	11918	5959	3973	2980	2384	1986	1490
						(312-468)	Fz	0.0003	0.0007	0.0014	0.0018	0.0023	0.0024	0.0025
							Feed (ipm)	14.3	16.7	22.2	21.5	21.9	19.1	14.9
	K STAINLESS STEELS (DIFFICULT) 304, 304L, 316, 316L	≤ 275 Bhn or ≤ 28 HRc	Profile 	≤ 0.5	≤ 1.5	340	RPM	10390	5195	3463	2598	2078	1732	1299
						(272-408)	Fz	0.0002	0.0006	0.0011	0.0014	0.0018	0.0019	0.0020
							Feed (ipm)	8.3	12.5	15.2	14.5	15.0	13.2	10.4
			Slot 	1	≤ 1	270	RPM	8251	4126	2750	2063	1650	1375	1031
						(216-324)	Fz	0.0002	0.0006	0.0011	0.0014	0.0018	0.0019	0.0020
							Feed (ipm)	6.6	9.9	12.1	11.6	11.9	10.5	8.3
K STAINLESS STEELS (PH) 13-8 PH, 15-5 PH, 17-4 PH, Custom 450		≤ 325 Bhn or ≤ 35 HRc	Profile 	≤ 0.5	≤ 1.5	310	RPM	9474	4737	3158	2368	1895	1579	1184
						(248-372)	Fz	0.0002	0.0006	0.0011	0.0014	0.0018	0.0019	0.0020
							Feed (ipm)	7.6	11.4	13.9	13.3	13.6	12.0	9.5
			Slot 	1	≤ 1	250	RPM	7640	3820	2547	1910	1528	1273	955
						(200-300)	Fz	0.0002	0.0006	0.0011	0.0014	0.0018	0.0019	0.0020
							Feed (ipm)	6.1	9.2	11.2	10.7	11.0	9.7	7.6
	K CAST IRONS (LOW & MEDIUM ALLOY) Gray, Malleable, Ductile	≤ 220 Bhn or ≤ 19 HRc	Profile 	≤ 0.5	≤ 1.5	445	RPM	13599	6800	4533	3400	2720	2267	1700
						(356-534)	Fz	0.0004	0.0010	0.0018	0.0024	0.0030	0.0031	0.0034
							Feed (ipm)	19.0	27.2	32.6	32.6	32.6	28.1	23.1
			Slot 	1	≤ 1	355	RPM	10849	5424	3616	2712	2170	1808	1356
						(284-426)	Fz	0.0004	0.0010	0.0018	0.0024	0.0030	0.0031	0.0034
							Feed (ipm)	15.2	21.7	26.0	26.0	26.0	22.4	18.4

continued on next page

FRACTIONAL Z-Carb



Series Z1B Fractional	Hardness	Ae x DC	Ap x DC	Vc (sfm)	DC • in								
					1/8	1/4	3/8	1/2	5/8	3/4	1		
K CAST IRONS (HIGH ALLOY) Gray, Malleable, Ductile	≤ 260 Bhn or ≤ 26 HRc	Profile 	≤ 0.5	≤ 1.5	340	RPM	10390	5195	3463	2598	2078	1732	1299
					(272-408)	Fz	0.0003	0.0007	0.0014	0.0018	0.0023	0.0024	0.0025
						Feed (ipm)	12.5	14.5	19.4	18.7	19.1	16.6	13.0
					270	RPM	8251	4126	2750	2063	1650	1375	1031
					(216-324)	Fz	0.0003	0.0007	0.0014	0.0018	0.0023	0.0024	0.0025
						Feed (ipm)	9.9	11.6	15.4	14.9	15.2	13.2	10.3
S SUPER ALLOYS (NICKEL, COBALT, IRON BASE) Inconel 601, 617, 625, Incoloy, Monel 400	≤ 300 Bhn or ≤ 32 HRc	Profile 	≤ 0.5	≤ 1.5	80	RPM	2445	1222	815	611	489	407	306
					(64-96)	Fz	0.0002	0.0004	0.0008	0.0010	0.0013	0.0014	0.0015
						Feed (ipm)	2.2	2.0	2.6	2.4	2.5	2.3	1.8
					65	RPM	1986	993	662	497	397	331	248
					(52-78)	Fz	0.0002	0.0004	0.0008	0.0010	0.0013	0.0014	0.0015
						Feed (ipm)	1.6	1.6	2.1	2.0	2.1	1.9	1.5
S SUPER ALLOYS (NICKEL, COBALT, IRON BASE) Inconel 718, X-750, Incoloy, Waspaloy, Hastelloy, Rene	≤ 400 Bhn or ≤ 43 HRc	Profile 	≤ 0.5	≤ 1.5	62	RPM	1895	947	632	474	379	316	237
					(50-74)	Fz	0.0001	0.0003	0.0005	0.0007	0.0008	0.0009	0.0010
						Feed (ipm)	0.8	1.1	1.3	1.3	1.2	1.1	0.9
					50	RPM	1497	749	499	374	299	250	187
					(40-60)	Fz	0.0001	0.0003	0.0005	0.0007	0.0008	0.0009	0.0010
						Feed (ipm)	0.6	0.9	1.0	1.0	1.0	0.9	0.7
S TITANIUM ALLOYS Pure Titanium, Ti6Al4V, Ti6Al2Sn4Zr2Mo, Ti4Al4Mo2Sn0.5Si	≤ 350 Bhn or ≤ 38 HRc	Profile 	≤ 0.5	≤ 1.5	215	RPM	6570	3285	2190	1643	1314	1095	821
					(172-258)	Fz	0.0002	0.0005	0.0010	0.0013	0.0016	0.0017	0.0018
						Feed (ipm)	5.3	6.6	8.8	8.5	8.4	7.4	5.9
					170	RPM	5195	2598	1732	1299	1039	866	649
					(136-204)	Fz	0.0002	0.0005	0.0010	0.0013	0.0016	0.0017	0.0018
						Feed (ipm)	4.2	5.2	6.9	6.8	6.6	5.9	4.7
S TITANIUM ALLOYS (DIFFICULT) Ti10Al2Fe3Al, Ti5Al5V5Mo3Cr, Ti7Al4Mo, Ti3Al8V6Cr4Zr4Mo, Ti6Al6V6Sn, Ti15V3 Cr3Sn3Al	≤ 440 Bhn or ≤ 47 HRc	Profile 	≤ 0.5	≤ 1.5	75	RPM	2292	1146	764	573	458	382	287
					(60-90)	Fz	0.0002	0.0005	0.0010	0.0013	0.0016	0.0017	0.0018
						Feed (ipm)	1.8	2.3	3.1	3.0	2.9	2.6	2.1
					60	RPM	1834	917	611	458	367	306	229
					(48-72)	Fz	0.0002	0.0005	0.0010	0.0013	0.0016	0.0017	0.0018
						Feed (ipm)	1.5	1.8	2.4	2.4	2.3	2.1	1.7
H TOOL STEELS A2, D2, H13, L2, M2, P20, S7, T15, W2	≤ 375 Bhn or ≤ 40 HRc	Profile 	≤ 0.5	≤ 1.5	185	RPM	5654	2827	1885	1413	1131	942	707
					(148-222)	Fz	0.0002	0.0005	0.0010	0.0013	0.0016	0.0017	0.0018
						Feed (ipm)	4.5	5.7	7.5	7.3	7.2	6.4	5.1
					145	RPM	4431	2216	1477	1108	886	739	554
					(116-174)	Fz	0.0002	0.0005	0.0010	0.0013	0.0016	0.0017	0.0018
						Feed (ipm)	3.5	4.4	5.9	5.8	5.7	5.0	4.0

Bhn (Brinell) HRc (Rockwell C)
 $rpm = Vc \times 3.82 / DC$
 $ipm = Fz \times 4 \times rpm$
 reduce speed and feed for materials harder than listed
 reduce feed and Ae when finish milling (.02 x DC maximum)
 refer to the SGS Tool Wizard® for complete technical information (www.kyocera-sgstool.com)

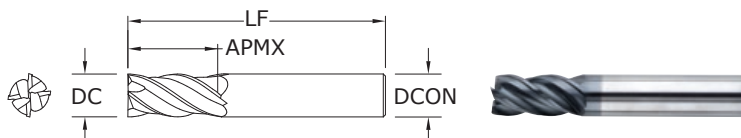
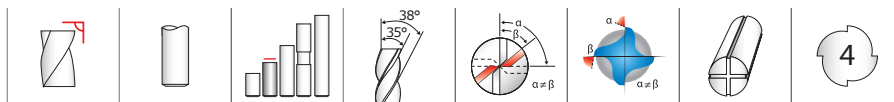

Z1M
METRIC SERIES

TOLERANCES (mm)

3–6 DIAMETER

DC = +0,000/-0,030

DCON = h₆

>6–10 DIAMETER

DC = +0,000/-0,040

DCON = h₆

>10–25 DIAMETER

DC = +0,000/-0,050

DCON = h₆

STEELS

STAINLESS STEELS

CAST IRON

HIGH TEMP ALLOYS

TITANIUM

HARDENED STEELS

CUTTING DIAMETER DC	LENGTH OF CUT APMX	OVERALL LENGTH LF	SHANK DIAMETER DCON	EDP NO.	
				Ti-NAMITE-X (TX)	JetStream
3,0	8,0	57,0	6,0	46357	—
4,0	11,0	57,0	6,0	46358	—
5,0	13,0	57,0	6,0	46359	—
6,0	13,0	57,0	6,0	46360	—
8,0	19,0	63,0	8,0	46362	—
10,0	22,0	72,0	10,0	46364	—
12,0	26,0	83,0	12,0	46366	—
14,0	26,0	83,0	14,0	46368	46506
16,0	32,0	92,0	16,0	46370	46507
18,0	32,0	92,0	18,0	46372	46508
20,0	38,0	104,0	20,0	46374	46509
25,0	38,0	104,0	25,0	46376	46510

Refer to page 47 for speed & feed recommendations

- Variable rake geometry alters and controls the cutting dynamic taking chatter suppression to an unprecedented level
- Unequal helix design reduces damaging harmonics by changing the angle at which each cutting edge enters and exits the material
- Unequal flute spacing helps to disrupt the rhythmic pattern created by the cutting edge helping to suppress damaging harmonics
- Optimal material removal rates through increased feed and depths of cut
- Recommended for materials ≤ 45 HRC (≤ 420 Bhn)

For patent information visit www.ksptpatents.com

METRIC Z-Carb

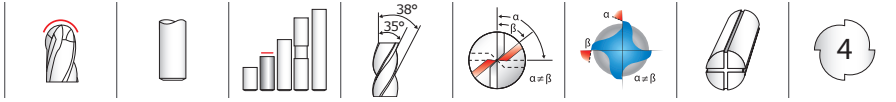

Z1MB METRIC SERIES

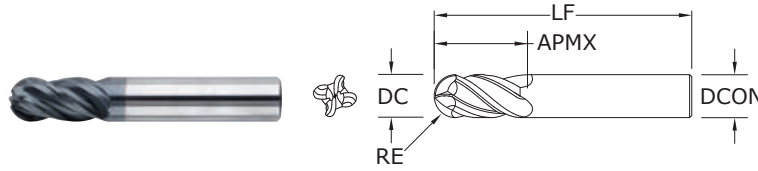

- Unequal helix design reduces damaging harmonics by changing the angle at which each cutting edge enters and exits the material
- Unequal flute spacing helps to disrupt the rhythmic pattern created by the cutting edge helping to suppress damaging harmonics
- Optimal material removal rates through increased feed and depths of cut
- Ball nose design ideal for finishing operations in complex workpieces
- Recommended for materials ≤ 45 HRc (≤ 420 Bhn)

CUTTING DIAMETER DC	LENGTH OF CUT APMX	mm		EDP NO.	
		OVERALL LENGTH LF	SHANK DIAMETER DCON	Ti-NAMITE-X (TX)	JetStream
3,0	8,0	57,0	6,0	46354	—
4,0	11,0	57,0	6,0	46355	—
5,0	13,0	57,0	6,0	46356	—
6,0	13,0	57,0	6,0	46343	—
8,0	19,0	63,0	8,0	46344	—
10,0	22,0	72,0	10,0	46345	—
12,0	26,0	83,0	12,0	46346	—
14,0	26,0	83,0	14,0	46347	46518
16,0	32,0	92,0	16,0	46348	46519
18,0	32,0	92,0	18,0	46349	46520
20,0	38,0	104,0	20,0	46350	46521
25,0	38,0	104,0	25,0	46351	46522

RE = 1/2 Cutting Diameter (DC)

TOLERANCES (mm)

3–6 DIAMETER

DC = $+0,000/-0,030$
DCON = h_6

RE = $+0,000/-0,015$

>6–10 DIAMETER

DC = $+0,000/-0,040$

DCON = h_6

RE = $+0,000/-0,020$

>10–25 DIAMETER

DC = $+0,000/-0,050$

DCON = h_6

RE = $+0,000/-0,025$

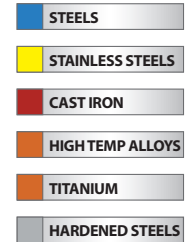

For patent information visit www.ksptpatents.com

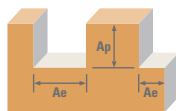

Series Z1MB Metric	Hardness	Ae x DC	Ap x DC	Vc (m/min)	DC • mm									
					3	6	8	10	12	16	20	25		
CARBON STEELS 1018, 1040, 1080, 1090, 10L50, 1140, 1212, 12L15, 1525, 1536	≤ 275 Bhn or ≤ 28 HRc	Profile 	≤ 0.5	≤ 1.5	169	RPM	17934	8967	6725	5380	4484	3363	2690	2152
					(135-203)	Fz	0.009	0.024	0.041	0.051	0.060	0.079	0.086	0.088
						Feed (mm/min)	654	861	1091	1090	1076	1067	927	753
	Slot 	1	≤ 1	134	RPM	14218	7109	5332	4265	3555	2666	2133	1706	
				(107-161)	Fz	0.009	0.024	0.041	0.051	0.060	0.079	0.086	0.088	
					Feed (mm/min)	519	682	865	864	853	846	735	597	
ALLOY STEELS 4140, 4150, 4320, 5120, 5150, 8630, 86L20, 50100	≤ 375 Bhn or ≤ 40 HRc	Profile 	≤ 0.5	≤ 1.5	96	RPM	10179	5089	3817	3054	2545	1909	1527	1221
					(77-115)	Fz	0.007	0.019	0.030	0.037	0.046	0.061	0.067	0.068
						Feed (mm/min)	274	391	456	456	464	469	407	330
	Slot 	1	≤ 1	76	RPM	8078	4039	3029	2424	2020	1515	1212	969	
				(61-91)	Fz	0.007	0.019	0.030	0.037	0.046	0.061	0.067	0.068	
					Feed (mm/min)	217	310	362	362	368	372	323	262	
STAINLESS STEELS (FREE MACHINING) 303, 416, 420F, 430F, 440F	≤ 275 Bhn or ≤ 28 HRc	Profile 	≤ 0.5	≤ 1.5	149	RPM	15834	7917	5938	4750	3958	2969	2375	1900
					(119-179)	Fz	0.007	0.017	0.030	0.037	0.043	0.059	0.064	0.063
						Feed (mm/min)	456	532	709	709	684	699	608	475
	Slot 	1	≤ 1	119	RPM	12602	6301	4726	3781	3151	2363	1890	1512	
				(95-143)	Fz	0.007	0.017	0.030	0.037	0.043	0.059	0.064	0.063	
					Feed (mm/min)	363	423	565	565	544	557	484	378	
STAINLESS STEELS (DIFFICULT) 304, 304L, 316, 316L	≤ 275 Bhn or ≤ 28 HRc	Profile 	≤ 0.5	≤ 1.5	104	RPM	10987	5493	4120	3296	2747	2060	1648	1318
					(83-124)	Fz	0.005	0.014	0.023	0.029	0.034	0.046	0.051	0.050
						Feed (mm/min)	211	316	387	387	369	380	334	264
	Slot 	1	≤ 1	82	RPM	8725	4362	3272	2617	2181	1636	1309	1047	
				(66-99)	Fz	0.005	0.014	0.023	0.029	0.034	0.046	0.051	0.050	
					Feed (mm/min)	168	251	307	307	293	302	265	209	
STAINLESS STEELS (PH) 13-8 PH, 15-5 PH, 17-4 PH, Custom 450	≤ 325 Bhn or ≤ 35 HRc	Profile 	≤ 0.5	≤ 1.5	94	RPM	10017	5009	3756	3005	2504	1878	1503	1202
					(76-113)	Fz	0.005	0.014	0.023	0.029	0.034	0.046	0.051	0.050
						Feed (mm/min)	192	288	353	353	337	346	305	240
	Slot 	1	≤ 1	76	RPM	8078	4039	3029	2424	2020	1515	1212	969	
				(61-91)	Fz	0.005	0.014	0.023	0.029	0.034	0.046	0.051	0.050	
					Feed (mm/min)	155	233	284	284	271	279	246	194	
CAST IRONS (LOW & MEDIUM ALLOY) Gray, Malleable, Ductile	≤ 220 Bhn or ≤ 19 HRc	Profile 	≤ 0.5	≤ 1.5	136	RPM	14380	7190	5392	4314	3595	2696	2157	1726
					(109-163)	Fz	0.008	0.024	0.038	0.048	0.058	0.077	0.083	0.085
						Feed (mm/min)	483	690	828	828	828	828	713	587
	Slot 	1	≤ 1	108	RPM	11471	5736	4302	3441	2868	2151	1721	1377	
				(87-130)	Fz	0.008	0.024	0.038	0.048	0.058	0.077	0.083	0.085	
					Feed (mm/min)	385	551	661	661	661	661	569	468	

continued on next page

METRIC Z-Carb

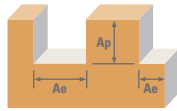

Series Z1MB Metric	Hardness	Ae x DC	Ap x DC	Vc (m/min)	DC • mm															
					3	6	8	10	12	16	20	25								
K	CAST IRONS (HIGH ALLOY) Gray, Malleable, Ductile	≤ 260 Bhn or ≤ 26 HRc	Profile 	≤ 0.5	≤ 1.5	104	RPM	10987	5493	4120	3296	2747	2060	1648	1318					
						(83-124)	Fz	0.007	0.017	0.030	0.037	0.043	0.059	0.064	0.063					
						Feed (mm/min)	316	369	492	492	475	485	422	330						
						82	RPM	8725	4362	3272	2617	2181	1636	1309	1047					
						(66-99)	Fz	0.007	0.017	0.030	0.037	0.043	0.059	0.064	0.063					
						Feed (mm/min)	251	293	391	391	377	385	335	262						
S	SUPER ALLOYS (NICKEL, COBALT, IRON BASE) Inconel 601, 617, 625, Incoloy, Monel 400	≤ 300 Bhn or ≤ 32 HRc	Profile 	≤ 0.5	≤ 1.5	24	RPM	2585	1293	969	776	646	485	388	310					
						(20-29)	Fz	0.005	0.010	0.017	0.021	0.024	0.033	0.037	0.038					
						Feed (mm/min)	55	50	66	53	62	65	58	47						
						20	RPM	2100	1050	788	630	525	394	315	252					
						(16-24)	Fz	0.005	0.010	0.017	0.021	0.024	0.033	0.037	0.038					
						Feed (mm/min)	40	40	54	54	50	52	47	38						
						SUPER ALLOYS (NICKEL, COBALT, IRON BASE) Inconel 718, X-750, Incoloy, Waspaloy, Hastelloy, Rene	≤ 400 Bhn or ≤ 43 HRc	Profile 	≤ 0.5	≤ 1.5	19	RPM	2003	1002	751	601	501	376	301	240
											(15-23)	Fz	0.002	0.007	0.011	0.013	0.017	0.020	0.024	0.025
											Feed (mm/min)	19	29	32	32	34	31	29	24	
											15	RPM	1583	792	594	475	396	297	238	190
											(12-18)	Fz	0.002	0.007	0.011	0.013	0.017	0.020	0.024	0.025
											Feed (mm/min)	15	23	25	25	27	24	23	19	
TITANIUM ALLOYS Pure Titanium, Ti6Al4V, Ti6Al2Sn4Zr2Mo, Ti4Al4Mo2Sn0.5Si	≤ 350 Bhn or ≤ 38 HRc	Profile 	≤ 0.5	≤ 1.5	66	RPM	6947	3474	2605	2084	1737	1303	1042	834						
					(52-79)	Fz	0.005	0.012	0.021	0.027	0.031	0.041	0.045	0.045						
					Feed (mm/min)	133	167	222	222	217	213	189	150							
					52	RPM	5493	2747	2060	1648	1373	1030	824	659						
					(41-62)	Fz	0.005	0.012	0.021	0.027	0.031	0.041	0.045	0.045						
					Feed (mm/min)	105	132	176	176	171	169	149	119							
TITANIUM ALLOYS (DIFFICULT) Ti10Al2Fe3Al, Ti5Al5V5Mo3Cr, Ti7Al4Mo, Ti3Al8V6Cr4Zr4Mo, Ti6Al6V6Sn, Ti15V3 Cr3Sn3Al	≤ 440 Bhn or ≤ 47 HRc	Profile 	≤ 0.5	≤ 1.5	23	RPM	2424	1212	909	727	606	454	364	291						
					(18-27)	Fz	0.005	0.012	0.021	0.027	0.031	0.041	0.045	0.045						
					Feed (mm/min)	47	58	78	78	76	74	66	52							
					18	RPM	1939	969	727	582	485	364	291	233						
					(15-22)	Fz	0.005	0.012	0.021	0.027	0.031	0.041	0.045	0.045						
					Feed (mm/min)	37	47	62	62	60	60	53	42							
H	TOOL STEELS A2, D2, H13, L2, M2, P20, S7, T15, W2	≤ 375 Bhn or ≤ 40 HRc	Profile 	≤ 0.5	≤ 1.5	56	RPM	5978	2989	2242	1793	1495	1121	897	717					
						(45-68)	Fz	0.005	0.012	0.021	0.027	0.031	0.041	0.045	0.045					
						Feed (mm/min)	115	143	191	191	186	184	163	129						
						44	RPM	4686	2343	1757	1406	1171	879	703	562					
						(35-53)	Fz	0.005	0.012	0.021	0.027	0.031	0.041	0.045	0.045					
						Feed (mm/min)	90	112	150	150	146	144	127	101						

Bhn (Brinell) HRc (Rockwell C)
 $rpm = (Vc \times 1000) / (DC \times 3.14)$
 $mm/min = Fz \times 4 \times rpm$
 reduce speed and feed for materials harder than listed
 reduce feed and Ae when finish milling (.02 x DC maximum)
 feed rates listed have chip thinning adjustments included where applicable
 refer to the SGS Tool Wizard® for complete technical information (www.kyocera-sgstool.com)

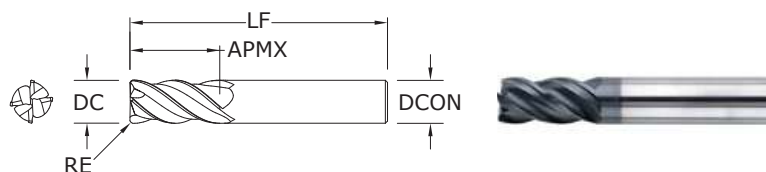
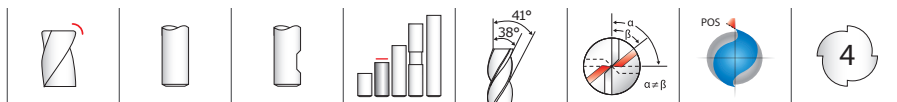

ZH1CR
FRACTIONAL SERIES

TOLERANCES (inch)

1/4 DIAMETER

DC = +0.0000/-0.0012

DCON = h_6

RE = +0.0000/-0.0020

>1/4-3/8 DIAMETER

DC = +0.0000/-0.0016

DCON = h_6

RE = +0.0000/-0.0020

>3/8-1 DIAMETER

DC = +0.0000/-0.0020

DCON = h_6

RE = +0.0000/-0.0020

HIGH TEMP ALLOYS

TITANIUM







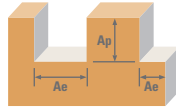

For patent information visit
www.ksptpatents.com

CUTTING DIAMETER DC	LENGTH OF CUT APMX	inch			EDP NO.	
		OVERALL LENGTH LF	SHANK DIAMETER DCON	CORNER RADIUS RE	Ti-NAMITE-A (AlTiN)	Ti-NAMITE-A (AlTiN) W/FLAT
1/4	1/2	2-1/2	1/4	.020	36570	—
1/4	3/4	2-1/2	1/4	.020	36616	—
5/16	13/16	2-1/2	5/16	.020	36571	—
3/8	7/8	2-1/2	3/8	.020	36572	36555
7/16	1	2-3/4	7/16	.020	36573	36556
1/2	1	3	1/2	.030	36574	36557
1/2	1-1/4	3-1/4	1/2	.030	36618	36617
9/16	1-1/8	3-1/2	9/16	.030	36575	36558
5/8	1-1/4	3-1/2	5/8	.040	36576	36559
3/4	1-1/2	4	3/4	.040	36577	36560
1	1-1/2	4	1	.040	36578	36561

- The original Z-Carb design with an enhanced core and higher helix suited for the demands of high temperature alloys
- Unequal flute spacing helps to disrupt the rhythmic pattern created by the cutting edge helping to suppress damaging harmonics
- Optimal material removal rates through increased feed and depths of cut for difficult to machine materials
- Enhanced corner geometry with tight tolerance corner radii
- Recommended for materials ≤ 45 HRc (≤ 420 Bhn)

FRACTIONAL Z-Carb-HTA



Series ZH1CR Fractional	Hardness	Ae x DC	Ap x DC	Vc (sfm)	Diameter (DC) (inch)					
					1/4	3/8	1/2	3/4	1	
SUPER ALLOYS (NICKEL, COBALT, IRON BASE) Inconel 601, 617, 625, Incoloy, Monel 400	Profile  ≤ 300 Bhn or ≤ 32 HRc	≤ 0.5	≤ 1.5	85	RPM	1299	866	649	433	325
				(68-102)	Fz	0.0007	0.0012	0.0017	0.0020	0.0023
					Feed (ipm)	3.6	4.2	4.4	3.5	3.0
	Slot  1	≤ 1	70	RPM	1070	713	535	357	267	
			(56-84)	Fz	0.0007	0.0012	0.0017	0.0020	0.0023	
				Feed (ipm)	3.0	3.4	3.6	2.9	2.5	
SUPER ALLOYS (NICKEL, COBALT, IRON BASE) Inconel 718, X-750, Incoloy, Waspaloy, Hastelloy, Rene	Profile  ≤ 400 Bhn or ≤ 43 HRc	≤ 0.5	≤ 1.5	70	RPM	1070	713	535	357	267
				(56-84)	Fz	0.0005	0.0009	0.0012	0.0014	0.0016
					Feed (ipm)	2.1	2.6	2.6	2.0	1.7
	Slot  1	≤ 1	55	RPM	840	560	420	280	210	
			(44-66)	Fz	0.0005	0.0009	0.0012	0.0014	0.0016	
				Feed (ipm)	1.7	2.0	2.0	1.6	1.3	
TITANIUM ALLOYS Pure Titanium, Ti6Al4V, Ti6Al2Sn4Zr2Mo, Ti4Al4Mo2Sn0.5Si	Profile  ≤ 350 Bhn or ≤ 38 HRc	≤ 0.5	≤ 1.5	215	RPM	3285	2190	1643	1095	821
				(172-258)	Fz	0.0008	0.0015	0.0020	0.0024	0.0028
					Feed (ipm)	10.5	13.1	13.1	10.5	9.2
	Slot  1	≤ 1	170	RPM	2598	1732	1299	866	649	
			(136-204)	Fz	0.0008	0.0015	0.0020	0.0024	0.0028	
				Feed (ipm)	8.3	10.4	10.4	8.3	7.3	
TITANIUM ALLOYS (DIFFICULT) Ti10Al2Fe3Al, Ti5Al5V5Mo3Cr, Ti7Al4Mo, Ti3Al8V6Cr4Zr4Mo, Ti6Al6V6Sn, Ti15V3 Cr3Sn3Al	Profile  ≤ 440 Bhn or ≤ 47 HRc	≤ 0.5	≤ 1.5	75	RPM	1146	764	573	382	287
				(60-90)	Fz	0.0008	0.0015	0.0020	0.0024	0.0028
					Feed (ipm)	3.7	4.6	4.6	3.7	3.2
	Slot  1	≤ 1	60	RPM	917	611	458	306	229	
			(48-72)	Fz	0.0008	0.0015	0.0020	0.0024	0.0028	
				Feed (ipm)	2.9	3.7	3.7	2.9	2.6	

Bhn (Brinell) HRc (Rockwell C)

rpm = Vc x 3.82 / DC

ipm = Fz x 4 x rpm

reduce speed and feed for materials harder than listed

reduce feed and Ae when finish milling (.02 x DC maximum)

feed rates listed have chip thinning adjustments included where applicable

refer to the SGS Tool Wizard® for complete technical information (www.kyocera-sgstool.com)

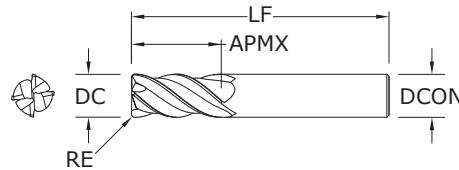
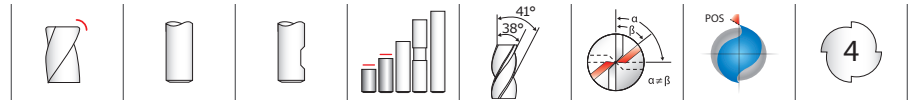

**ZH1MCRS •
ZH1MCR**
METRIC SERIES

TOLERANCES (mm)

6 DIAMETER

DC = +0,000/-0,030

DCON = h_6

RE = +0,000/-0,050

>6-10 DIAMETER

DC = +0,000/-0,040

DCON = h_6

RE = +0,000/-0,050

>10-20 DIAMETER

DC = +0,000/-0,050

DCON = h_6

RE = +0,000/-0,050

HIGH TEMP ALLOYS

TITANIUM





For patent
information visit
www.ksptpatents.com

CUTTING DIAMETER DC	LENGTH OF CUT APMX	mm			EDP NO.	
		OVERALL LENGTH LF	SHANK DIAMETER DCON	CORNER RADIUS RE	Ti-NAMITE-A (AlTiN)	Ti-NAMITE-A (AlTiN) W/FLAT
6,0	10,0	54,0	6,0	0,50	—	42712
6,0	13,0	57,0	6,0	0,5	46450	—
6,0	13,0	57,0	6,0	1,0	46451	—
6,0	13,0	57,0	6,0	1,5	46452	—
8,0	12,0	58,0	8,0	0,50	—	42713
8,0	19,0	63,0	8,0	0,5	46453	—
8,0	19,0	63,0	8,0	1,0	46454	—
8,0	19,0	63,0	8,0	1,5	46455	—
10,0	14,0	66,0	10,0	0,50	—	42714
10,0	22,0	72,0	10,0	0,5	46456	—
10,0	22,0	72,0	10,0	1,0	46457	—
10,0	22,0	72,0	10,0	1,5	46458	—
10,0	22,0	72,0	10,0	2,0	46459	—
12,0	16,0	73,0	12,0	0,75	—	42715
12,0	26,0	83,0	12,0	0,5	46460	46471
12,0	26,0	83,0	12,0	1,0	46461	46472
12,0	26,0	83,0	12,0	1,5	46462	46473
12,0	26,0	83,0	12,0	2,0	46463	46474
12,0	26,0	83,0	12,0	3,0	46464	46475
16,0	22,0	82,0	16,0	1,00	—	42716
16,0	32,0	92,0	16,0	1,5	46465	46476
16,0	32,0	92,0	16,0	2,0	46466	46477
16,0	32,0	92,0	16,0	3,0	46467	46478
16,0	32,0	92,0	16,0	4,0	46482	46483
20,0	26,0	92,0	20,0	1,00	—	42717
20,0	38,0	104,0	20,0	3,0	46468	46479
20,0	38,0	104,0	20,0	4,0	46469	46480
20,0	38,0	104,0	20,0	5,0	46470	46481

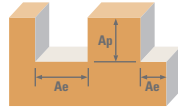
- The original Z-Carb design with an enhanced core and higher helix suited for the demands of high temperature alloys
- Unequal flute spacing helps to disrupt the rhythmic pattern created by the cutting edge helping to suppress damaging harmonics
- Optimal material removal rates through increased feed and depths of cut for difficult to machine materials
- Enhanced corner geometry with tight tolerance corner radii
- Recommended for materials ≤ 45 HRc (≤ 420 Bhn)

Z-Carb-HTA



Series ZH1MCRS, ZH1MCR Metric	Hardness	Ae x DC	Ap x DC	Vc (m/min)	DC • mm					
					6	10	12	20		
SUPER ALLOYS (NICKEL, COBALT, IRON BASE) Inconel 601, 617, 625, Incoloy, Monel 400	≤ 300 Bhn or ≤ 32 HRc	Profile 	≤ 0.5	≤ 1.5	26	RPM	1373	824	687	412
					(21-31)	Fz	0.017	0.032	0.041	0.053
						Feed (mm/min)	93	105	113	87
					21	RPM	1131	679	565	339
					(17-26)	Fz	0.017	0.032	0.041	0.053
						Feed (mm/min)	77	87	93	72
SUPER ALLOYS (NICKEL, COBALT, IRON BASE) Inconel 718, X-750, Incoloy, Waspaloy, Hastelloy, Rene	≤ 400 Bhn or ≤ 43 HRc	Profile 	≤ 0.5	≤ 1.5	21	RPM	1131	679	565	339
					(17-26)	Fz	0.012	0.024	0.029	0.037
						Feed (mm/min)	54	65	66	50
					17	RPM	889	533	444	267
					(13-20)	Fz	0.012	0.024	0.029	0.037
						Feed (mm/min)	43	51	52	39
TITANIUM ALLOYS Pure Titanium, Ti6Al4V, Ti6Al2Sn4Zr2Mo, Ti4Al4Mo2Sn0.5Si	≤ 350 Bhn or ≤ 38 HRc	Profile 	≤ 0.5	≤ 1.5	66	RPM	3474	2084	1737	1042
					(52-79)	Fz	0.019	0.041	0.049	0.057
						Feed (mm/min)	264	342	340	238
					52	RPM	2747	1648	1373	824
					(41-62)	Fz	0.019	0.041	0.049	0.057
						Feed (mm/min)	209	270	269	188
TITANIUM ALLOYS (DIFFICULT) Ti10Al2Fe3Al, Ti5Al5V5Mo3Cr, Ti7Al4Mo, Ti3Al8V6Cr4Zr4Mo, Ti6Al6V6Sn, Ti15V3 Cr3Sn3Al	≤ 440 Bhn or ≤ 47 HRc	Profile 	≤ 0.5	≤ 1.5	23	RPM	1212	727	606	364
					(18-27)	Fz	0.019	0.041	0.049	0.057
						Feed (mm/min)	92	119	119	83
					18	RPM	969	582	485	291
					(15-22)	Fz	0.019	0.041	0.049	0.057
						Feed (mm/min)	74	95	95	66

Bhn (Brinell) HRc (Rockwell C)
 rpm = (Vc x 1000) / (DC x 3.14)
 ipm = Fz x 4 x rpm
 reduce speed and feed for materials harder than listed
 reduce feed and Ae when finish milling (.02 x DC maximum)
 feed rates listed have chip thinning adjustments included where applicable
 refer to the SGS Tool Wizard® for complete technical information (www.kyocera-sgstool.com)

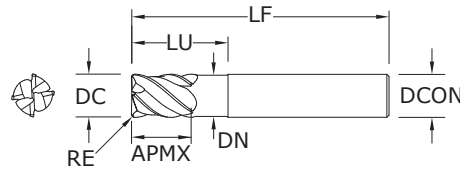

ZD1CR FRACTIONAL SERIES

TOLERANCES (inch)

1/8-1/4 DIAMETER

DC = +0.0000/-0.0012

DCON = h₆

RE = +0.0000/-0.0020

>1/4-3/8 DIAMETER

DC = +0.0000/-0.0016

DCON = h₆

RE = +0.0000/-0.0020

>3/8-3/4 DIAMETER

DC = +0.0000/-0.0020

DCON = h₆

RE = +0.0000/-0.0020

HARDENED STEELS

For patent information visit www.ksptpatents.com

CUTTING DIAMETER DC	LENGTH OF CUT APMX	OVERALL LENGTH LF	inch				CORNER RADIUS RE	EDP NO. Ti-NAMITE-X
			SHANK DIAMETER DCON	REACH LU	NECK DIAMETER DN			
1/8	5/32	2-1/2	1/4	1/2	.110	.010	36780	
3/16	7/32	2-1/2	1/4	3/4	.172	.020	36781	
1/4	9/32	2-1/2	1/4	3/4	.235	.020	36782	
5/16	13/32	2-1/2	5/16	1	.297	.040	36783	
3/8	15/32	2-1/2	3/8	1	.360	.040	36784	
7/16	9/16	2-3/4	7/16	1	.422	.040	36785	
1/2	5/8	3	1/2	1-1/4	.485	.040	36786	
1/2	5/8	4-1/2	1/2	2-1/4	.485	.040	36787	
5/8	3/4	3-1/2	5/8	1-1/2	.610	.040	36788	
5/8	3/4	4-1/2	5/8	2-1/4	.610	.040	36789	
5/8	3/4	5-1/2	5/8	3-1/4	.610	.040	36790	
3/4	15/16	4	3/4	1-3/4	.735	.060	36791	
3/4	15/16	4-1/2	3/4	2-1/4	.735	.060	36792	
3/4	15/16	5-1/2	3/4	3-1/4	.735	.060	36793	

- The original Z-Carb design with negative rake, heavy core, and higher helix for strength and shearing of hard mold & die materials
- Unequal flute spacing helps to disrupt the rhythmic pattern created by the cutting edge helping to suppress damaging harmonics
- Enhanced corner geometry with tight tolerance corner radii
- Recommended for materials 35-60HRC (327 to 654 Bhn)

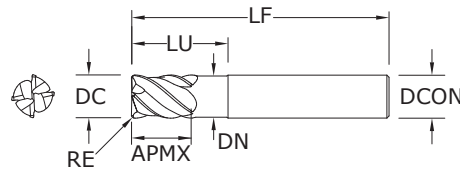

ZD1MCR METRIC SERIES

TOLERANCES (mm)

3-6 DIAMETER

DC = +0,000/-0,030

DCON = h₆

RE = +0,000/-0,050

>6-10 DIAMETER

DC = +0,000/-0,040

DCON = h₆

RE = +0,000/-0,050

>10-20 DIAMETER

DC = +0,000/-0,050

DCON = h₆

RE = +0,000/-0,050

HARDENED STEELS

For patent information visit www.ksptpatents.com

CUTTING DIAMETER DC	LENGTH OF CUT APMX	OVERALL LENGTH LF	mm				CORNER RADIUS RE	EDP NO. Ti-NAMITE-X
			SHANK DIAMETER DCON	REACH LU	NECK DIAMETER DN			
3,0	4,0	57,0	6,0	15,0	2,62	0,2	46560	
4,0	5,0	57,0	6,0	15,0	3,61	0,3	46561	
5,0	6,0	57,0	6,0	15,0	4,60	0,5	46562	
6,0	7,0	57,0	6,0	15,0	5,61	1,0	46563	
8,0	10,0	63,0	8,0	25,0	7,62	1,0	46564	
10,0	12,0	72,0	10,0	30,0	9,60	1,0	46565	
12,0	15,0	83,0	12,0	35,0	11,61	1,0	46566	
16,0	20,0	92,0	16,0	45,0	15,60	1,5	46567	
20,0	24,0	104,0	20,0	55,0	19,61	2,0	46568	

- The original Z-Carb design with negative rake, heavy core, and higher helix for strength and shearing of hard mold & die materials
- Unequal flute spacing helps to disrupt the rhythmic pattern created by the cutting edge helping to suppress damaging harmonics
- Enhanced corner geometry with tight tolerance corner radii
- Recommended for materials 35-60HRC (327 to 654 Bhn)

Z-Carb-MD

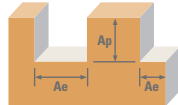

Series ZD1CR Fractional	Hardness	Ae x DC	Ap x DC	Vc (sfm)	Diameter (DC) (inch)							
					1/8	1/4	3/8	1/2	5/8	3/4		
TOOL STEELS A2, D2, H13, L2, M2, P20, S7, T15, W2	≤ 375 Bhn or ≤ 40 HRc	Profile 	≤ 0.4	≤ 1	405	RPM	12377	6188	4126	3094	2475	2063
					(324-486)	Fz	0.0005	0.0012	0.0023	0.0030	0.0039	0.0042
						Feed (ipm)	24.8	29.7	38.0	37.1	38.6	34.7
	≤ 475 Bhn or ≤ 50 HRc	Slot 	1	≤ 0.4	320	RPM	9779	4890	3260	2445	1956	1630
					(256-384)	Fz	0.0005	0.0012	0.0023	0.0030	0.0039	0.0042
						Feed (ipm)	19.6	23.5	30.0	29.3	30.5	27.4
TOOL STEELS A2, D2, H13, L2, M2, P20, S7, T15, W2	≤ 475 Bhn or ≤ 50 HRc	Profile 	≤ 0.4	≤ 1	210	RPM	6418	3209	2139	1604	1284	1070
					(168-252)	Fz	0.0004	0.0010	0.0019	0.0025	0.0032	0.0035
						Feed (ipm)	10.3	12.8	16.3	16.0	16.4	15.0
	≤ 655 Bhn or ≤ 60 HRc	Slot 	1	≤ 0.4	170	RPM	5195	2598	1732	1299	1039	866
					(136-204)	Fz	0.0004	0.0010	0.0019	0.0025	0.0032	0.0035
						Feed (ipm)	8.3	10.4	13.2	13.0	13.3	12.1
TOOL STEELS A2, D2, H13, L2, M2, P20, S7, T15, W2	≤ 655 Bhn or ≤ 60 HRc	Profile 	≤ 0.4	≤ 1	90	RPM	2750	1375	917	688	550	458
					(72-108)	Fz	0.0002	0.0005	0.0010	0.0013	0.0017	0.0018
						Feed (ipm)	2.2	2.8	3.7	3.6	3.7	3.3
TOOL STEELS A2, D2, H13, L2, M2, P20, S7, T15, W2	≤ 655 Bhn or ≤ 60 HRc	Slot 	1	≤ 0.4	70	RPM	2139	1070	713	535	428	357
					(56-84)	Fz	0.0002	0.0005	0.0010	0.0013	0.0017	0.0018
						Feed (ipm)	1.7	2.1	2.9	2.8	2.9	2.6

Bhn (Brinell) HRc (Rockwell C)
 rpm = Vc x 3.82 / DC
 ipm = Fz x 4 x rpm
 reduce speed and feed for materials harder than listed
 reduce feed and Ae when finish milling (.02 x DC maximum)
 feed rates listed have chip thinning adjustments included where applicable
 refer to the SGS Tool Wizard® for complete technical information (www.kyocera-sgstool.com)

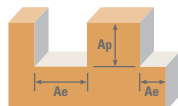

Series ZD1MCR Metric	Hardness	Ae x DC	Ap x DC	Vc (m/min)	Diameter (DC) (mm)								
					3	6	8	10	12	16	20		
TOOL STEELS A2, D2, H13, L2, M2, P20, S7, T15, W2	≤ 375 Bhn or ≤ 40 HRc	Profile 	≤ 0.4	≤ 1	123	RPM	13087	6544	4908	3926	3272	2454	1963
					(99-148)	Fz	0.012	0.029	0.049	0.061	0.072	0.083	0.112
						Feed (mm/min)	628	754	963	963	942	817	879
	≤ 475 Bhn or ≤ 50 HRc	Slot 	1	≤ 0.4	98	RPM	10340	5170	3878	3102	2585	1939	1551
					(78-117)	Fz	0.012	0.029	0.049	0.061	0.072	0.083	0.112
						Feed (mm/min)	496	596	761	761	744	645	695
TOOL STEELS A2, D2, H13, L2, M2, P20, S7, T15, W2	≤ 475 Bhn or ≤ 50 HRc	Profile 	≤ 0.4	≤ 1	64	RPM	6786	3393	2545	2036	1696	1272	1018
					(51-77)	Fz	0.010	0.024	0.041	0.051	0.060	0.068	0.093
						Feed (mm/min)	261	326	413	413	407	347	380
	≤ 655 Bhn or ≤ 60 HRc	Slot 	1	≤ 0.4	52	RPM	5493	2747	2060	1648	1373	1030	824
					(41-62)	Fz	0.010	0.024	0.041	0.051	0.060	0.068	0.093
						Feed (mm/min)	211	264	334	334	330	281	308
TOOL STEELS A2, D2, H13, L2, M2, P20, S7, T15, W2	≤ 655 Bhn or ≤ 60 HRc	Profile 	≤ 0.4	≤ 1	27	RPM	2908	1454	1091	872	727	545	436
					(22-33)	Fz	0.005	0.012	0.021	0.027	0.031	0.036	0.048
						Feed (mm/min)	56	70	93	93	91	79	84
TOOL STEELS A2, D2, H13, L2, M2, P20, S7, T15, W2	≤ 655 Bhn or ≤ 60 HRc	Slot 	1	≤ 0.4	21	RPM	2262	1131	848	679	565	424	339
					(17-26)	Fz	0.005	0.012	0.021	0.027	0.031	0.036	0.048
						Feed (mm/min)	43	54	72	72	71	62	65

Bhn (Brinell) HRc (Rockwell C)
 rpm = (Vc x 1000) / (DC x 3.14)
 ipm = Fz x 4 x rpm
 reduce speed and feed for materials harder than listed
 reduce feed and Ae when finish milling (.02 x DC maximum)
 feed rates listed have chip thinning adjustments included where applicable
 refer to the SGS Tool Wizard® for complete technical information (www.kyocera-sgstool.com)

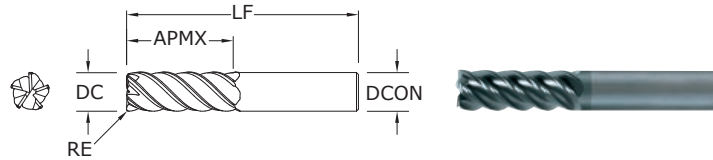
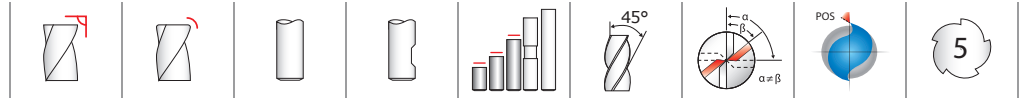

55 • 55CR FRACTIONAL SERIES

TOLERANCES (inch)

DC = +0.0000/-0.0020

DCON = h_6

RE = +0.0000/-0.0020

- STEELS
- STAINLESS STEELS
- CAST IRON
- HIGH TEMP ALLOYS
- TITANIUM
- HARDENED STEELS

For patent information visit www.ksptpatents.com

CUTTING DIAMETER DC	LENGTH OF CUT APMX	inch			EDP NO.	
		OVERALL LENGTH LF	SHANK DIAMETER DCON	CORNER RADIUS RE	Ti-NAMITE-A (AITiN)	Ti-NAMITE-A (AITiN) W/FLAT
1/8	1/4	1-1/2	1/8	—	32672	—
1/8	1/4	1-1/2	1/8	.010	32606	—
1/8	1/2	1-1/2	1/8	—	32655	—
1/8	1/2	1-1/2	1/8	.010	32607	—
5/32	5/16	2	3/16	.010	32608	—
5/32	9/16	2	3/16	—	32656	—
5/32	9/16	2	3/16	.010	32609	—
3/16	5/16	2	3/16	—	32673	—
3/16	5/16	2	3/16	.010	32610	—
3/16	5/8	2	3/16	—	32657	—
3/16	5/8	2	3/16	.010	32611	—
7/32	3/8	2	1/4	.015	32612	—
7/32	3/4	2-1/2	1/4	.015	32613	—
7/32	3/4	2-1/2	1/4	—	32658	—
1/4	3/8	2	1/4	.015	32614	—
1/4	3/8	2	1/4	—	32674	—
1/4	3/4	2-1/2	1/4	—	32659	—
1/4	3/4	2-1/2	1/4	.015	32615	—
1/4	1-1/4	4	1/4	.015	32616	—
5/16	7/16	2	5/16	—	32675	—
5/16	7/16	2	5/16	.015	32619	—
5/16	13/16	2-1/2	5/16	—	32660	—
5/16	13/16	2-1/2	5/16	.015	32620	—
5/16	1-1/4	4	5/16	.015	32621	—
3/8	1/2	2	3/8	—	32676	32677
3/8	1/2	2	3/8	.015	32625	32591
3/8	1/2	2	3/8	.030	32592	32593
3/8	1	2-1/2	3/8	—	32661	32662
3/8	1	2-1/2	3/8	.015	32626	32628
3/8	1	2-1/2	3/8	.030	32573	32574
3/8	1-1/2	4	3/8	.015	32627	—
3/8	1-1/2	4	3/8	.030	32569	—

continued on next page

- Unequal indexing, high helix and an ideal rake and relief combination for unmatched finishing capability
- The choice when peak finish quality is the requirement
- Enhanced corner geometry with tight tolerance corner radii
- Recommended for materials ≤ 45 HRc (≤ 420 Bhn)

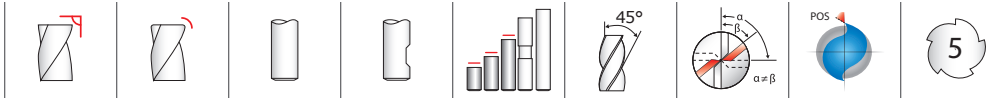

**55 •
55CR**
FRACTIONAL SERIES

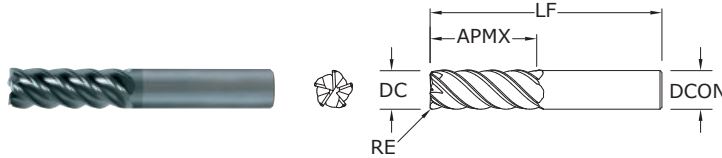

CONTINUED

CUTTING DIAMETER DC	LENGTH OF CUT APMX	inch			EDP NO.	
		OVERALL LENGTH LF	SHANK DIAMETER DCON	CORNER RADIUS RE	Ti-NAMITE-A (AITiN)	Ti-NAMITE-A (AITiN) W/FLAT
7/16	1	2-3/4	7/16	—	32663	—
7/16	1	2-3/4	7/16	.015	32632	—
7/16	2	4	7/16	.015	32633	—
1/2	5/8	2-1/2	1/2	—	32678	32679
1/2	5/8	2-1/2	1/2	.030	32594	32595
1/2	5/8	2-1/2	1/2	.060	32596	32597
1/2	1-1/4	3	1/2	—	32664	32665
1/2	1-1/4	3	1/2	.030	32575	32576
1/2	1-1/4	3	1/2	.060	32577	32578
1/2	2	4	1/2	.030	32685	—
1/2	2	4	1/2	.060	32686	—
5/8	3/4	3	5/8	—	32680	32681
5/8	3/4	3	5/8	.030	32598	32599
5/8	3/4	3	5/8	.060	32600	32601
5/8	1-5/8	3-1/2	5/8	—	32666	32667
5/8	1-5/8	3-1/2	5/8	.030	32579	32580
5/8	1-5/8	3-1/2	5/8	.060	32581	32582
5/8	2-1/2	5	5/8	.030	32570	—
5/8	2-1/2	5	5/8	.060	32687	—
3/4	1	3	3/4	.030	32602	32603
3/4	1	3	3/4	.060	32604	32605
3/4	1-5/8	4	3/4	—	32668	32669
3/4	1-5/8	4	3/4	.030	32583	32584
3/4	1-5/8	4	3/4	.060	32585	32586
3/4	3-1/4	6	3/4	.030	32571	—
3/4	3-1/4	6	3/4	.060	32688	—
1	1-1/2	4	1	—	32670	32671
1	1-1/2	4	1	.030	32587	32588
1	1-1/2	4	1	.060	32589	32590
1	2-5/8	6	1	.030	32572	—
1	2-5/8	6	1	.060	32689	—

TOLERANCES (inch)

DC = +0.0000/-0.0020
DCON = \pm h₆
RE = +0.0000/-0.0020

- STEELS
- STAINLESS STEELS
- CAST IRON
- HIGH TEMP ALLOYS
- TITANIUM
- HARDENED STEELS

For patent information visit www.ksptpatents.com

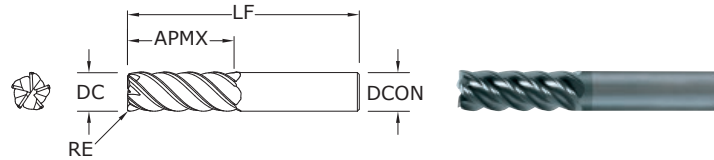
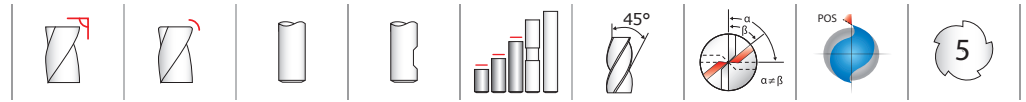

**55M •
55MCR**
METRIC SERIES

TOLERANCES (mm)

DC = +0,000/-0,050

DCON = h₆

RE = +0,000/-0,050

- STEELS
- STAINLESS STEELS
- CAST IRON
- HIGH TEMP ALLOYS
- TITANIUM
- HARDENED STEELS

For patent information visit www.ksptpatents.com

CUTTING DIAMETER DC	LENGTH OF CUT APMX	mm			EDP NO.	
		OVERALL LENGTH LF	SHANK DIAMETER DCON	CORNER RADIUS RE	Ti-NAMITE-A (AITIN)	Ti-NAMITE-A (AITIN) W/FLAT
6,0	12,0	50,0	6,0	—	42606	—
6,0	12,0	50,0	6,0	0,5	42660	—
6,0	19,0	63,0	6,0	—	42607	—
6,0	19,0	63,0	6,0	0,25	42661	—
6,0	19,0	63,0	6,0	0,5	42662	—
6,0	19,0	63,0	6,0	1,0	42663	—
6,0	19,0	63,0	6,0	1,5	42664	—
6,0	25,0	75,0	6,0	—	42608	—
6,0	25,0	75,0	6,0	0,5	42665	—
8,0	12,0	50,0	8,0	—	42609	—
8,0	12,0	50,0	8,0	0,5	42666	—
8,0	20,0	63,0	8,0	—	42610	—
8,0	20,0	63,0	8,0	0,5	42667	—
8,0	20,0	63,0	8,0	1,0	42668	—
8,0	20,0	63,0	8,0	1,5	42669	—
8,0	20,0	63,0	8,0	2,0	42670	—
8,0	25,0	75,0	8,0	—	42611	—
8,0	25,0	75,0	8,0	0,5	42671	—
10,0	16,0	50,0	10,0	—	42612	—
10,0	16,0	50,0	10,0	0,5	42672	—
10,0	22,0	75,0	10,0	—	42622	42613
10,0	22,0	75,0	10,0	0,5	42673	—
10,0	22,0	75,0	10,0	1,0	42674	—
10,0	22,0	75,0	10,0	1,5	42675	—
10,0	22,0	75,0	10,0	2,0	42676	—
10,0	22,0	75,0	10,0	2,5	42677	—
10,0	38,0	100,0	10,0	—	42614	—
10,0	38,0	100,0	10,0	0,5	42678	—
12,0	19,0	63,0	12,0	—	42615	—
12,0	19,0	63,0	12,0	0,5	42679	—
12,0	25,0	75,0	12,0	—	42616	42623
12,0	25,0	75,0	12,0	0,5	42680	—

continued on next page

- Unequal indexing, high helix and an ideal rake and relief combination for unmatched finishing capability
- The choice when peak finish quality is the requirement
- Enhanced corner geometry with tight tolerance corner radii
- Recommended for materials ≤ 45 HRC (≤ 420 Bhn)

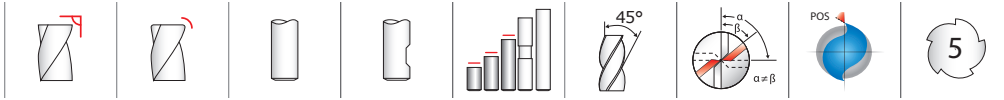

**55M •
55MCR**
METRIC SERIES

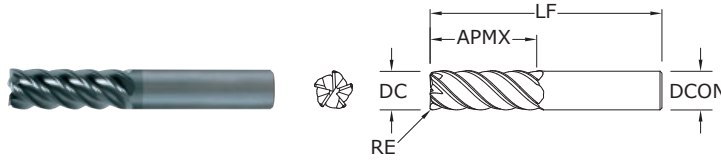

- Unequal indexing, high helix and an ideal rake and relief combination for unmatched finishing capability
- The choice when peak finish quality is the requirement
- Enhanced corner geometry with tight tolerance corner radii
- Recommended for materials ≤ 45 HRc (≤ 420 Bhn)

CUTTING DIAMETER DC	LENGTH OF CUT APMX	mm			EDP NO.	
		OVERALL LENGTH LF	SHANK DIAMETER DCON	CORNER RADIUS RE	Ti-NAMITE-A (AlTiN)	Ti-NAMITE-A (AlTiN) W/FLAT
12,0	25,0	75,0	12,0	1,0	42681	—
12,0	25,0	75,0	12,0	1,5	42682	—
12,0	25,0	75,0	12,0	2,0	42683	—
12,0	25,0	75,0	12,0	2,5	42684	—
12,0	25,0	75,0	12,0	3,0	42685	—
12,0	50,0	100,0	12,0	—	42617	—
12,0	50,0	100,0	12,0	0,5	42686	—
12,0	50,0	100,0	12,0	3,0	42630	—
12,0	50,0	100,0	12,0	4,0	42631	—
16,0	32,0	89,0	16,0	—	42618	42624
16,0	32,0	89,0	16,0	1,0	42687	—
16,0	32,0	89,0	16,0	1,5	42688	—
16,0	32,0	89,0	16,0	2,0	42689	—
16,0	32,0	89,0	16,0	2,5	42690	—
16,0	32,0	89,0	16,0	3,0	42691	—
16,0	32,0	89,0	16,0	4,0	42692	—
16,0	50,0	100,0	16,0	—	42626	—
16,0	50,0	100,0	16,0	2,0	42656	—
16,0	50,0	100,0	16,0	2,5	42657	—
16,0	50,0	100,0	16,0	3,0	42658	—
16,0	50,0	100,0	16,0	4,0	42659	—
16,0	50,0	100,0	16,0	5,0	42628	—
16,0	75,0	150,0	16,0	—	42619	—
16,0	75,0	150,0	16,0	1,0	42693	—
16,0	75,0	150,0	16,0	3,0	42632	—
16,0	75,0	150,0	16,0	4,0	42633	—
20,0	38,0	100,0	20,0	—	42620	42625
20,0	38,0	100,0	20,0	1,0	42694	—
20,0	38,0	100,0	20,0	1,5	42695	—
20,0	38,0	100,0	20,0	2,0	42696	—
20,0	38,0	100,0	20,0	2,5	42697	—
20,0	38,0	100,0	20,0	3,0	42698	—
20,0	38,0	100,0	20,0	4,0	42699	—
20,0	38,0	100,0	20,0	5,0	42700	—

TOLERANCES (mm)

DC = +0,000/-0,050
DCON = h_6
RE = +0,000/-0,050

- STEELS
- STAINLESS STEELS
- CAST IRON
- HIGH TEMP ALLOYS
- TITANIUM
- HARDENED STEELS

For patent information visit www.ksptpatents.com

continued on next page

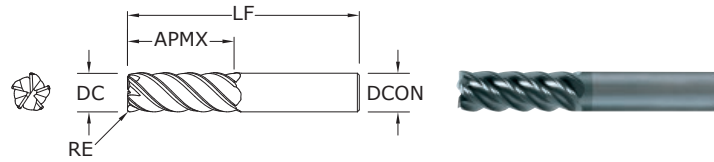
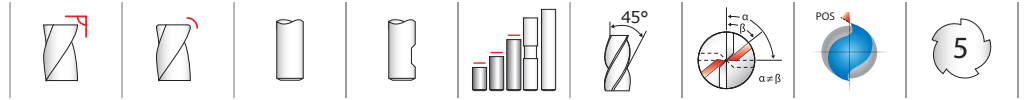

**55M •
55MCR**
METRIC SERIES

CONTINUED

TOLERANCES (mm)

DC = +0,000/-0,050

DCON = h_6

RE = +0,000/-0,050

- STEELS
- STAINLESS STEELS
- CAST IRON
- HIGH TEMP ALLOYS
- TITANIUM
- HARDENED STEELS

For patent information visit www.ksptpatents.com

CUTTING DIAMETER DC	LENGTH OF CUT APMX	mm			EDP NO.	
		OVERALL LENGTH LF	SHANK DIAMETER DCON	CORNER RADIUS RE	Ti-NAMITE-A (AITiN)	Ti-NAMITE-A (AITiN) W/FLAT
20,0	38,0	100,0	20,0	6,0	42648	—
20,0	50,0	100,0	20,0	—	42627	—
20,0	50,0	100,0	20,0	2,0	42649	—
20,0	50,0	100,0	20,0	2,5	42650	—
20,0	50,0	100,0	20,0	3,0	42651	—
20,0	50,0	100,0	20,0	4,0	42652	—
20,0	50,0	100,0	20,0	5,0	42653	—
20,0	50,0	100,0	20,0	6,0	42654	—
20,0	75,0	150,0	20,0	—	42621	—
20,0	75,0	150,0	20,0	1,0	42701	—
20,0	75,0	150,0	20,0	2,0	42702	—
20,0	75,0	150,0	20,0	3,0	42703	—
20,0	75,0	150,0	20,0	4,0	42704	—
20,0	75,0	150,0	20,0	5,0	42705	—
20,0	75,0	150,0	20,0	6,0	42655	—

V-Carb



55B

FRACTIONAL SERIES

- Unequal indexing, high helix and an ideal rake and relief combination for unmatched finishing capability
- The choice when peak finish quality is the requirement
- Ball nose design ideal for finishing operations in complex workpieces
- Recommended for materials ≤ 45 HRc (≤ 420 Bhn)

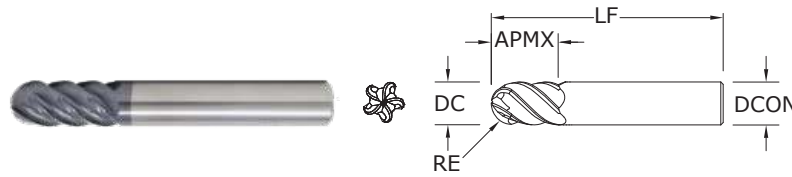

inch				EDP NO.
CUTTING DIAMETER DC	LENGTH OF CUT APMX	OVERALL LENGTH LF	SHANK DIAMETER DCON	Ti-NAMITE-A (AITiN)
1/4	3/4	2-1/2	1/4	32500
5/16	13/16	2-1/2	5/16	32501
3/8	1	2-1/2	3/8	32502
1/2	1-1/4	3	1/2	32503
5/8	1-5/8	3-1/2	5/8	32504
3/4	1-5/8	4	3/4	32505
1	1-1/2	4	1	32506

RE = 1/2 Cutting Diameter (DC)

TOLERANCES (inch)

DC = +0.0000/-0.0020
 DCON = h_6
 RE = +0.0005/-0.0010

- STEELS
- STAINLESS STEELS
- CAST IRON
- HIGH TEMP ALLOYS
- TITANIUM
- HARDENED STEELS

For patent information visit www.ksptpatents.com

55MB

METRIC SERIES

- Unequal indexing, high helix and an ideal rake and relief combination for unmatched finishing capability
- The choice when peak finish quality is the requirement
- Ball nose design ideal for finishing operations in complex workpieces
- Recommended for materials ≤ 45 HRc (≤ 420 Bhn)

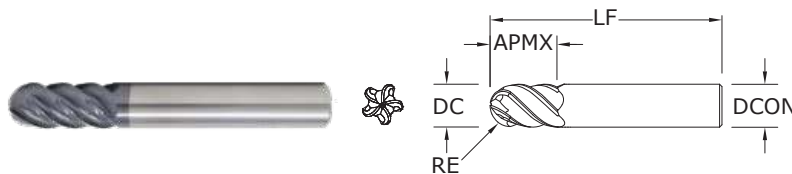

mm				EDP NO.
CUTTING DIAMETER DC	LENGTH OF CUT APMX	OVERALL LENGTH LF	SHANK DIAMETER DCON	Ti-NAMITE-A (AITiN)
6,0	13,0	57,0	6,0	42750
8,0	19,0	63,0	8,0	42751
10,0	22,0	72,0	10,0	42752
12,0	26,0	83,0	12,0	42753
16,0	32,0	92,0	16,0	42754
20,0	38,0	104,0	20,0	42755

RE = 1/2 Cutting Diameter (DC)

TOLERANCES (mm)

DC = +0,000/-0,050
 DCON = h_6
 RE = +0,000/-0,025

- STEELS
- STAINLESS STEELS
- CAST IRON
- HIGH TEMP ALLOYS
- TITANIUM
- HARDENED STEELS

For patent information visit www.ksptpatents.com

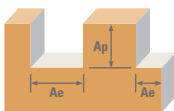

Series	Hardness	Ae x DC	Ap x DC	Vc (sfm)	DC • in								
					1/8	1/4	3/8	1/2	5/8	3/4	1		
Series 55, 55CR, 55B Fractional CARBON STEELS 1018, 1040, 1080, 1090, 10L50, 1140, 1212, 12L15, 1525, 1536 ALLOY STEELS 4140, 4150, 4320, 5120, 5150, 8630, 86L20, 50100 STAINLESS STEELS (FREE MACHINING) 303, 416, 420F, 430F, 440F STAINLESS STEELS (DIFFICULT) 304, 304L, 316, 316L STAINLESS STEELS (PH) 13-8 PH, 15-5 PH, 17-4 PH, Custom 450 CAST IRONS (LOW & MEDIUM ALLOY) Gray, Malleable, Ductile	≤ 275 Bhn or ≤ 28 HRc	Profile 	≤ 0.25	≤ 1.5	385	RPM	11766	5883	3922	2941	2353	1961	1471
					(308-462)	Fz	0.0004	0.0009	0.0017	0.0023	0.0029	0.0028	0.0032
						Feed (ipm)	20.6	26.5	33.3	33.8	34.1	27.5	23.5
		HSM 	≤ 0.05	≤ 2	630	RPM	19253	9626	6418	4813	3851	3209	2407
					(504-756)	Fz	0.0007	0.0018	0.0034	0.0046	0.0057	0.0055	0.0064
						Feed (ipm)	67.4	86.6	109.1	110.7	109.7	88.2	77.0
	≤ 375 Bhn or ≤ 40 HRc	Profile 	≤ 0.25	≤ 1.5	325	RPM	9932	4966	3311	2483	1986	1655	1242
					(260-390)	Fz	0.0003	0.0007	0.0013	0.0017	0.0022	0.0021	0.0024
						Feed (ipm)	12.9	17.4	21.5	21.1	21.9	17.4	14.9
		HSM 	≤ 0.05	≤ 2	530	RPM	16197	8098	5399	4049	3239	2699	2025
					(424-636)	Fz	0.0005	0.0014	0.0026	0.0034	0.0043	0.0041	0.0048
						Feed (ipm)	42.1	56.7	70.2	68.8	69.6	55.3	48.6
≤ 275 Bhn or ≤ 28 HRc	Profile 	≤ 0.25	≤ 1.5	370	RPM	11307	5654	3769	2827	2261	1885	1413	
				(296-444)	Fz	0.0003	0.0007	0.0013	0.0017	0.0022	0.0023	0.0024	
					Feed (ipm)	14.7	19.8	24.5	24.0	24.9	21.7	17.0	
	HSM 	≤ 0.05	≤ 2	560	RPM	17114	8557	5705	4278	3423	2852	2139	
				(448-672)	Fz	0.0005	0.0014	0.0026	0.0034	0.0043	0.0044	0.0048	
					Feed (ipm)	44.5	59.9	74.2	72.7	73.6	62.7	51.3	
≤ 275 Bhn or ≤ 28 HRc	Profile 	≤ 0.25	≤ 1.5	255	RPM	7793	3896	2598	1948	1559	1299	974	
				(204-306)	Fz	0.0002	0.0006	0.0012	0.0016	0.0020	0.0021	0.0023	
					Feed (ipm)	9.4	11.7	15.6	15.6	15.6	13.6	11.2	
	HSM 	≤ 0.05	≤ 2	385	RPM	11766	5883	3922	2941	2353	1961	1471	
				(308-462)	Fz	0.0005	0.0013	0.0024	0.0032	0.0040	0.0041	0.0045	
					Feed (ipm)	28.2	38.2	47.1	47.1	47.1	40.2	33.1	
≤ 325 Bhn or ≤ 35 HRc	Profile 	≤ 0.25	≤ 1.5	235	RPM	7182	3591	2394	1795	1436	1197	898	
				(188-282)	Fz	0.0002	0.0006	0.0010	0.0014	0.0017	0.0018	0.0019	
					Feed (ipm)	7.5	10.8	12.0	12.6	12.2	10.8	8.5	
	HSM 	≤ 0.05	≤ 2	355	RPM	10849	5424	3616	2712	2170	1808	1356	
				(284-426)	Fz	0.0004	0.0011	0.0021	0.0028	0.0034	0.0036	0.0039	
					Feed (ipm)	22.2	29.8	38.0	38.0	36.9	32.5	26.4	
≤ 220 Bhn or ≤ 19 HRc	Profile 	≤ 0.25	≤ 1.5	470	RPM	14363	7182	4788	3591	2873	2394	1795	
				(376-564)	Fz	0.0004	0.0009	0.0017	0.0023	0.0029	0.0030	0.0032	
					Feed (ipm)	25.1	32.3	40.7	41.3	41.7	35.9	28.7	
	HSM 	≤ 0.05	≤ 2	705	RPM	21545	10772	7182	5386	4309	3591	2693	
				(564-846)	Fz	0.0007	0.0018	0.0034	0.0046	0.0057	0.0059	0.0064	
					Feed (ipm)	75.4	97.0	122.1	123.9	122.8	105.9	86.2	

continued on next page

FRACTIONAL V-Carb

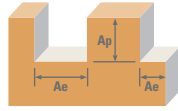

Series	Hardness	Ae x DC	Ap x DC	Vc (sfm)	DC • in									
					1/8	1/4	3/8	1/2	5/8	3/4	1			
K CAST IRONS (HIGH ALLOY) Gray, Malleable, Ductile	≤ 260 Bhn or ≤ 26 HRc	Profile	≤ 0.25	≤ 1.5	360	RPM	11002	5501	3667	2750	2200	1834	1375	
					(288-432)	Fz	0.0003	0.0007	0.0013	0.0017	0.0022	0.0023	0.0024	
					Feed (ipm)	14.3	19.3	23.8	23.4	24.2	21.1	16.5		
		HSM	≤ 0.05	≤ 2	540	RPM	16502	8251	5501	4126	3300	2750	2063	
					(432-648)	Fz	0.0005	0.0014	0.0026	0.0034	0.0043	0.0044	0.0048	
					Feed (ipm)	42.9	57.8	71.5	70.1	71.0	60.5	49.5		
	S SUPER ALLOYS (NICKEL, COBALT, IRON BASE) Inconel 601, 617, 625, Incoloy, Monel 400	≤ 300 Bhn or ≤ 32 HRc	Profile	≤ 0.25	≤ 1.5	70	RPM	2139	1070	713	535	428	357	267
						(56-84)	Fz	0.0002	0.0006	0.0010	0.0014	0.0017	0.0018	0.0019
						Feed (ipm)	2.2	3.2	3.6	3.7	3.6	3.2	2.5	
			HSM	≤ 0.05	≤ 2	107	RPM	3270	1635	1090	817	654	545	409
						(86-128)	Fz	0.0004	0.0011	0.0021	0.0028	0.0034	0.0036	0.0039
						Feed (ipm)	6.7	9.0	11.4	11.4	11.1	9.8	8.0	
≤ 400 Bhn or ≤ 43 HRc		Profile	≤ 0.25	≤ 1.5	55	RPM	1681	840	560	420	336	280	210	
					(44-66)	Fz	0.0002	0.0004	0.0008	0.0010	0.0013	0.0014	0.0015	
					Feed (ipm)	1.3	1.7	2.2	2.1	2.2	2.0	1.6		
		HSM	≤ 0.05	≤ 2	85	RPM	2598	1299	866	649	520	433	325	
					(68-102)	Fz	0.0003	0.0008	0.0015	0.0021	0.0026	0.0027	0.0029	
					Feed (ipm)	4.0	5.2	6.5	6.8	6.8	5.8	4.7		
≤ 350 Bhn or ≤ 38 HRc	Profile	≤ 0.25	≤ 1.5	235	RPM	7182	3591	2394	1795	1436	1197	898		
				(188-282)	Fz	0.0002	0.0006	0.0012	0.0016	0.0020	0.0021	0.0023		
				Feed (ipm)	7.2	10.8	14.4	14.4	14.4	12.6	10.3			
	HSM	≤ 0.05	≤ 2	390	RPM	11918	5959	3973	2980	2384	1986	1490		
				(312-468)	Fz	0.0005	0.0013	0.0024	0.0032	0.0040	0.0041	0.0045		
				Feed (ipm)	29.8	38.7	47.7	47.7	47.7	40.7	33.5			
≤ 440 Bhn or ≤ 47 HRc	Profile	≤ 0.25	≤ 1.5	85	RPM	2598	1299	866	649	520	433	325		
				(68-102)	Fz	0.0002	0.0006	0.0012	0.0016	0.0020	0.0021	0.0023		
				Feed (ipm)	2.6	3.9	5.2	5.2	5.2	4.5	3.7			
	HSM	≤ 0.05	≤ 2	140	RPM	4278	2139	1426	1070	856	713	535		
				(112-168)	Fz	0.0005	0.0013	0.0024	0.0032	0.0040	0.0042	0.0045		
				Feed (ipm)	10.7	13.9	17.1	17.1	17.1	15.0	12.0			
≤ 375 Bhn or ≤ 40 HRc	Profile	≤ 0.25	≤ 1.5	175	RPM	5348	2674	1783	1337	1070	891	669		
				(140-210)	Fz	0.0002	0.0005	0.0010	0.0013	0.0016	0.0017	0.0018		
				Feed (ipm)	5.3	6.7	8.9	8.7	8.6	7.6	6.0			
	HSM	≤ 0.05	≤ 2	290	RPM	8862	4431	2954	2216	1772	1477	1108		
				(232-348)	Fz	0.0004	0.0010	0.0019	0.0025	0.0032	0.0033	0.0035		
				Feed (ipm)	17.7	22.2	28.1	27.7	28.4	24.4	19.4			
H TOOL STEELS A2, D2, H13, L2, M2, P20, S7, T15, W2	≤ 375 Bhn or ≤ 40 HRc	Profile	≤ 0.25	≤ 1.5	175	RPM	5348	2674	1783	1337	1070	891	669	
					(140-210)	Fz	0.0002	0.0005	0.0010	0.0013	0.0016	0.0017	0.0018	
					Feed (ipm)	5.3	6.7	8.9	8.7	8.6	7.6	6.0		
	HSM	≤ 0.05	≤ 2	290	RPM	8862	4431	2954	2216	1772	1477	1108		
				(232-348)	Fz	0.0004	0.0010	0.0019	0.0025	0.0032	0.0033	0.0035		
				Feed (ipm)	17.7	22.2	28.1	27.7	28.4	24.4	19.4			

Bhn (Brinell) HRc (Rockwell C) HSM (High Speed Machining)
 rpm = Vc x 3.82 / DC
 ipm = Fz x 5 x rpm
 reduce speed and feed for materials harder than listed
 reduce feed and Ae when finish milling (.02 x DC maximum)
 reduce Ap to 1 x DC (maximum) when profile milling with long or extra long flute length tools
 feed rates listed have chip thinning adjustments included where applicable
 refer to the SGS Tool Wizard® for complete technical information (www.kyocera-sgstool.com)

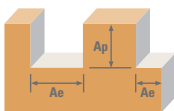





Series 55M, 55MCR, 55MB Metric	Hardness	Ae x DC	Ap x DC	Vc (m/min)	DC • mm							
					6	8	10	12	16	20		
P CARBON STEELS 1018, 1040, 1080, 1090, 10L50, 1140, 1212, 12L15, 1525, 1536	≤ 275 Bhn or ≤ 28 HRc	Profile 	≤ 0.25	≤ 1.5	117	RPM	6220	4665	3732	3110	2333	1866
					(94-141)	Fz	0.022	0.036	0.061	0.070	0.072	0.085
					Feed (mm/min)	672	846	1145	1082	836	796	
		HSM 	≤ 0.05	≤ 2	192	RPM	10179	7634	6107	5089	3817	3054
					(154-230)	Fz	0.043	0.073	0.123	0.137	0.141	0.154
					Feed (mm/min)	2198	2769	3746	3481	2687	2345	
	≤ 375 Bhn or ≤ 40 HRc	Profile 	≤ 0.25	≤ 1.5	99	RPM	5251	3938	3151	2626	1969	1575
					(79-119)	Fz	0.017	0.028	0.045	0.053	0.054	0.064
					Feed (mm/min)	441	546	571	693	529	504	
		HSM 	≤ 0.05	≤ 2	162	RPM	8563	6422	5138	4282	3211	2569
					(129-194)	Fz	0.034	0.055	0.091	0.103	0.105	0.128
					Feed (mm/min)	1438	1781	2329	2209	1685	1644	
M STAINLESS STEELS (FREE MACHINING) 303, 416, 420F, 430F, 440F	≤ 275 Bhn or ≤ 28 HRc	Profile 	≤ 0.25	≤ 1.5	113	RPM	5978	4484	3587	2989	2242	1793
					(90-135)	Fz	0.017	0.028	0.045	0.053	0.059	0.064
					Feed (mm/min)	502	622	813	789	660	574	
		HSM 	≤ 0.05	≤ 2	171	RPM	9048	6786	5429	4524	3393	2714
					(137-205)	Fz	0.034	0.055	0.091	0.103	0.113	0.128
					Feed (mm/min)	1520	1882	2461	2334	1911	1737	
	≤ 275 Bhn or ≤ 28 HRc	Profile 	≤ 0.25	≤ 1.5	78	RPM	4120	3090	2472	2060	1545	1236
					(62-93)	Fz	0.014	0.026	0.043	0.048	0.054	0.061
					Feed (mm/min)	297	396	527	494	415	379	
		HSM 	≤ 0.05	≤ 2	117	RPM	6220	4665	3732	3110	2333	1866
					(94-141)	Fz	0.031	0.051	0.085	0.096	0.105	0.120
					Feed (mm/min)	970	1194	1592	1493	1224	1120	
≤ 325 Bhn or ≤ 35 HRc	Profile 	≤ 0.25	≤ 1.5	72	RPM	3797	2848	2278	1898	1424	1139	
				(57-86)	Fz	0.014	0.021	0.037	0.041	0.046	0.051	
				Feed (mm/min)	273	304	425	387	328	289		
	HSM 	≤ 0.05	≤ 2	108	RPM	5736	4302	3441	2868	2151	1721	
				(87-130)	Fz	0.026	0.045	0.075	0.082	0.092	0.104	
				Feed (mm/min)	757	964	1285	1170	991	895		

continued on next page

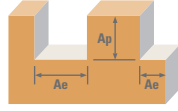
METRIC V-Carb

Series
55M, 55MCR,
55MB



Metric	Hardness	Ae x DC	Ap x DC	Vc (m/min)	DC • mm								
					6	8	10	12	16	20			
K	CAST IRONS (LOW & MEDIUM ALLOY) Gray, Malleable, Ductile	≤ 220 Bhn or ≤ 19 HRc	Profile 	≤ 0.25	≤ 1.5	143	RPM	7594	5695	4556	3797	2848	2278
						(115-172)	Fz	0.022	0.036	0.061	0.070	0.077	0.085
							Feed (mm/min)	820	1033	1397	1321	1093	972
						215	RPM	11391	8543	6834	5695	4271	3417
						(172-258)	Fz	0.043	0.073	0.123	0.137	0.151	0.171
							Feed (mm/min)	2460	3099	4192	3895	3226	2916
	CAST IRONS (HIGH ALLOY) Gray, Malleable, Ductile	≤ 260 Bhn or ≤ 26 HRc	Profile 	≤ 0.25	≤ 1.5	110	RPM	5816	4362	3490	2908	2181	1745
						(88-132)	Fz	0.017	0.028	0.045	0.053	0.059	0.064
							Feed (mm/min)	489	605	791	768	642	558
						165	RPM	8725	6544	5235	4362	3272	2617
						(132-198)	Fz	0.034	0.055	0.091	0.103	0.113	0.128
							Feed (mm/min)	1466	1815	2373	2251	1843	1675
S	SUPER ALLOYS (NICKEL, COBALT, IRON BASE) Inconel 601, 617, 625, Incoloy, Monel 400	≤ 300 Bhn or ≤ 32 HRc	Profile 	≤ 0.25	≤ 1.5	21	RPM	1131	848	679	565	424	339
						(17-26)	Fz	0.014	0.021	0.037	0.041	0.046	0.051
							Feed (mm/min)	81	90	127	115	98	86
						33	RPM	1729	1297	1037	864	648	519
						(26-39)	Fz	0.026	0.045	0.075	0.082	0.092	0.104
							Feed (mm/min)	228	290	387	353	299	270
	SUPER ALLOYS (NICKEL, COBALT, IRON BASE) Inconel 718, X-750, Incoloy, Waspaloy, Hastelloy, Rene	≤ 400 Bhn or ≤ 43 HRc	Profile 	≤ 0.25	≤ 1.5	17	RPM	889	666	533	444	333	267
						(13-20)	Fz	0.010	0.017	0.027	0.031	0.036	0.040
							Feed (mm/min)	43	57	71	69	60	53
						26	RPM	1373	1030	824	687	515	412
						(21-31)	Fz	0.019	0.032	0.056	0.062	0.069	0.077
							Feed (mm/min)	132	165	231	214	178	159

continued on next page

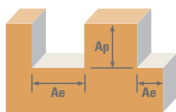

Series	Hardness	Ae x DC	Ap x DC	Vc (m/min)	DC • mm							
					6	8	10	12	16	20		
S	TITANIUM ALLOYS Pure Titanium, Ti6Al4V, Ti6Al2Sn4Zr2Mo, Ti4Al4Mo2Sn0.5Si ≤ 350 Bhn or ≤ 38 HRc	Profile	≤ 0.25	≤ 1.5	72	RPM	3797	2848	2278	1898	1424	1139
					(57-86)	Fz	0.014	0.026	0.043	0.048	0.054	0.061
					Feed (mm/min)	273	365	486	456	383	349	
		HSM	≤ 0.05	≤ 2	119	RPM	6301	4726	3781	3151	2363	1890
					(95-143)	Fz	0.031	0.051	0.085	0.096	0.105	0.120
					Feed (mm/min)	983	1210	1613	1512	1240	1134	
	TITANIUM ALLOYS (DIFFICULT) Ti10Al2Fe3Al, Ti5Al5V5Mo3Cr, Ti7Al4Mo, Ti3Al8V6Cr4Zr4Mo, Ti6Al6V6Sn, Ti15V3 Cr3Sn3Al ≤ 440 Bhn or ≤ 47 HRc	Profile	≤ 0.25	≤ 1.5	26	RPM	1373	1030	824	687	515	412
					(21-31)	Fz	0.014	0.026	0.043	0.048	0.054	0.061
					Feed (mm/min)	99	132	176	165	138	126	
		HSM	≤ 0.05	≤ 2	43	RPM	2262	1696	1357	1131	848	679
					(34-51)	Fz	0.031	0.051	0.085	0.096	0.108	0.120
					Feed (mm/min)	353	434	579	543	456	407	
H	TOOL STEELS A2, D2, H13, L2, M2, P20, S7, T15, W2 ≤ 375 Bhn or ≤ 40 HRc	Profile	≤ 0.25	≤ 1.5	53	RPM	2827	2121	1696	1414	1060	848
					(43-64)	Fz	0.012	0.021	0.035	0.038	0.044	0.048
					Feed (mm/min)	170	226	294	271	231	204	
		HSM	≤ 0.05	≤ 2	88	RPM	4686	3514	2811	2343	1757	1406
					(71-106)	Fz	0.024	0.041	0.067	0.077	0.084	0.093
					Feed (mm/min)	562	712	937	900	742	656	

Bhn (Brinell) HRc (Rockwell C) HSM (High Speed Machining)
 rpm = (Vc x 1000) / (DC x 3.14)
 mm/min = Fz x 5 x rpm
 reduce speed and feed for materials harder than listed
 reduce feed and Ae when finish milling (.02 x DC maximum)
 reduce Ap to 1 x DC (maximum) when profile milling with long or extra long flute length tools
 feed rates listed have chip thinning adjustments included where applicable
 refer to the SGS Tool Wizard® for complete technical information (www.kyocera-sgstool.com)

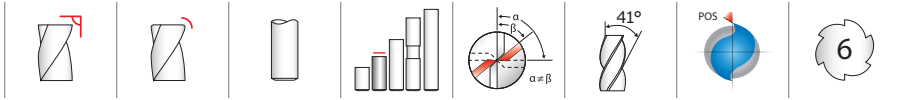

**51 •
51CR**
FRACTIONAL SERIES

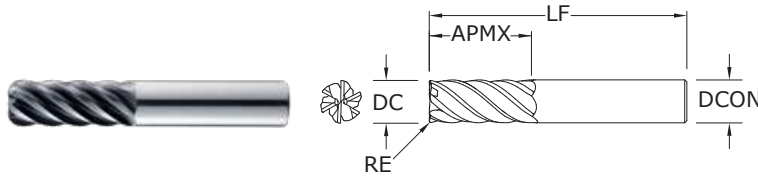

- Engineered for High Speed Milling using Trochoidal and Peel Milling techniques
- Eccentric relief provides superior strength and smoother surface finish
- Enhanced corner geometry with tight tolerance corner radii
- Recommended for materials ≤ 45 HRc (≤ 420 Bhn)

CUTTING DIAMETER DC	LENGTH OF CUT APMX	inch			CORNER RADIUS RE	EDP NO. TI-NAMITE-X (TX)
		OVERALL LENGTH LF	SHANK DIAMETER DCON			
1/4	3/4	2-1/2	1/4	—	35100	
1/4	3/4	2-1/2	1/4	.015	35112	
1/4	3/4	2-1/2	1/4	.030	35150	
3/8	1	2-1/2	3/8	—	35101	
3/8	1	2-1/2	3/8	.015	35113	
3/8	1	2-1/2	3/8	.030	35114	
1/2	1-1/4	3	1/2	—	35102	
1/2	1-1/4	3	1/2	.015	35151	
1/2	1-1/4	3	1/2	.030	35115	
1/2	1-1/4	3	1/2	.060	35152	
1/2	1-1/4	3	1/2	.090	35116	
1/2	1-1/4	3	1/2	.120	35117	
5/8	1-5/8	3-1/2	5/8	—	35103	
5/8	1-5/8	3-1/2	5/8	.015	35153	
5/8	1-5/8	3-1/2	5/8	.030	35118	
5/8	1-5/8	3-1/2	5/8	.060	35154	
5/8	1-5/8	3-1/2	5/8	.090	35119	
5/8	1-5/8	3-1/2	5/8	.120	35120	
5/8	1-5/8	3-1/2	5/8	.190	35155	
3/4	1-5/8	4	3/4	—	35104	
3/4	1-5/8	4	3/4	.030	35121	
3/4	1-5/8	4	3/4	.060	35156	
3/4	1-5/8	4	3/4	.090	35122	
3/4	1-5/8	4	3/4	.120	35123	
3/4	1-5/8	4	3/4	.190	35157	
3/4	1-5/8	4	3/4	.250	35158	
1	2-5/8	6	1	—	35105	
1	2-5/8	6	1	.030	35124	
1	2-5/8	6	1	.060	35159	
1	2-5/8	6	1	.090	35125	
1	2-5/8	6	1	.120	35126	
1	2-5/8	6	1	.190	35160	
1	2-5/8	6	1	.250	35161	

TOLERANCES (inch)

- DC = +0.0000/-0.0020
 DCON = H6
 RE = +0.0000/-0.0020

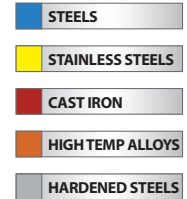

For patent information visit www.kspatents.com

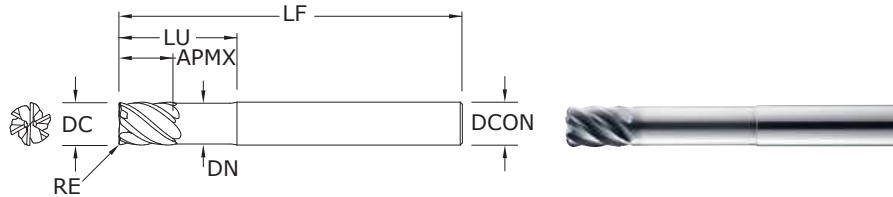
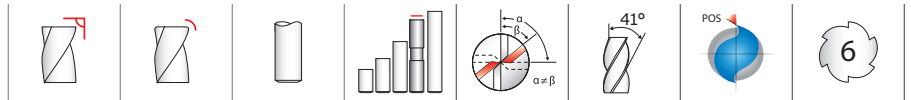
**51L •
51LC**
FRACTIONAL SERIES
TOLERANCES (inch)
DC = +0.0000/-0.0020

DCON = h_6
RE = +0.0000/-0.0020

- STEELS
- STAINLESS STEELS
- HIGH TEMP ALLOYS
- TITANIUM
- HARDENED STEELS

 For patent information visit
www.kspatents.com

CUTTING DIAMETER DC	LENGTH OF CUT APMX	OVERALL LENGTH LF	inch				CORNER RADIUS RE	EDP NO. TI-NAMITE-X (TX)
			SHANK DIAMETER DCON	REACH LU	NECK DIAMETER DN			
1/4	3/8	4	1/4	1-1/8	.237	—	35106	
1/4	3/8	4	1/4	1-1/8	.237	.015	35127	
1/4	3/8	4	1/4	1-1/8	.237	.030	35180	
3/8	1/2	4	3/8	2-1/8	.356	—	35107	
3/8	1/2	4	3/8	2-1/8	.356	.015	35128	
3/8	1/2	4	3/8	2-1/8	.356	.030	35129	
1/2	5/8	4	1/2	2-1/4	.475	—	35108	
1/2	5/8	4	1/2	2-1/4	.475	.015	35181	
1/2	5/8	4	1/2	2-1/4	.475	.030	35130	
1/2	5/8	4	1/2	2-1/4	.475	.060	35182	
1/2	5/8	4	1/2	2-1/4	.475	.090	35131	
1/2	5/8	4	1/2	2-1/4	.475	.120	35132	
5/8	3/4	5	5/8	2-1/2	.594	—	35109	
5/8	3/4	5	5/8	2-1/2	.594	.015	35183	
5/8	3/4	5	5/8	2-1/2	.594	.030	35133	
5/8	3/4	5	5/8	2-1/2	.594	.060	35184	
5/8	3/4	5	5/8	2-1/2	.594	.090	35134	
5/8	3/4	5	5/8	2-1/2	.594	.120	35135	
5/8	3/4	5	5/8	2-1/2	.594	.190	35185	
3/4	1	6	3/4	3-3/8	.712	—	35110	
3/4	1	6	3/4	3-3/8	.712	.030	35136	
3/4	1	6	3/4	3-3/8	.712	.060	35186	
3/4	1	6	3/4	3-3/8	.712	.090	35137	
3/4	1	6	3/4	3-3/8	.712	.120	35138	
3/4	1	6	3/4	3-3/8	.712	.190	35187	
3/4	1	6	3/4	3-3/8	.712	.250	35188	
1	1-1/4	6	1	3-3/8	.950	—	35111	
1	1-1/4	6	1	3-3/8	.950	.030	35139	
1	1-1/4	6	1	3-3/8	.950	.060	35189	
1	1-1/4	6	1	3-3/8	.950	.090	35140	
1	1-1/4	6	1	3-3/8	.950	.120	35141	
1	1-1/4	6	1	3-3/8	.950	.190	35190	
1	1-1/4	6	1	3-3/8	.950	.250	35191	

- Engineered for High Speed Milling using Trochoidal and Peel Milling techniques
- Eccentric relief provides superior strength and smoother surface finish
- Necked design with blended diameter transitions provide clearance to reach
- Enhanced corner geometry with tight tolerance corner radii
- Recommended for materials \leq 45 HRC (\leq 420 Bhn)

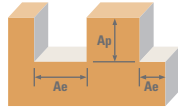

Series
51, 51CR, 51L,
51LC

Fractional	Hardness	Ae x DC	Ap x DC	Vc (sfm)	DC • in							
					1/4	3/8	1/2	5/8	3/4	1		
P CARBON STEELS 1018, 1040, 1080, 1090, 10L50, 1140, 1212, 12L15, 1525, 1536	≤ 275 Bhn or ≤ 28 HRc	Profile 	≤ 0.1	≤ 1	720	RPM	11002	7334	5501	4401	3667	2750
					(576-864)	Fz	0.0020	0.0035	0.0050	0.0055	0.0061	0.0071
					Feed (ipm)	132	154	165	145	134	117	
		HSM 	≤ 0.05	≤ 2	915	RPM	13981	9321	6991	5592	4660	3495
					(732-1098)	Fz	0.0028	0.0053	0.0070	0.0077	0.0085	0.0100
					Feed (ipm)	235	296	294	258	238	210	
	≤ 375 Bhn or ≤ 40 HRc	Profile 	≤ 0.1	≤ 1	490	RPM	7487	4991	3744	2995	2496	1872
					(392-588)	Fz	0.0015	0.0029	0.0038	0.0042	0.0046	0.0054
					Feed (ipm)	67	87	85	75	69	61	
		HSM 	≤ 0.05	≤ 2	620	RPM	9474	6316	4737	3789	3158	2368
					(496-744)	Fz	0.0021	0.0039	0.0052	0.0057	0.0062	0.0073
					Feed (ipm)	119	148	148	130	117	104	
M STAINLESS STEELS (FREE MACHINING) 303, 416, 420F, 430F, 440F	≤ 275 Bhn or ≤ 28 HRc	Profile 	≤ 0.1	≤ 1	510	RPM	7793	5195	3896	3117	2598	1948
					(459-561)	Fz	0.0015	0.0028	0.0038	0.0041	0.0045	0.0053
					Feed (ipm)	70	87	89	77	70	62	
		HSM 	≤ 0.05	≤ 2	650	RPM	9932	6621	4966	3973	3311	2483
					(585-715)	Fz	0.0021	0.0038	0.0051	0.0056	0.0061	0.0072
					Feed (ipm)	125	151	152	133	121	107	
	≤ 275 Bhn or ≤ 28 HRc	Profile 	≤ 0.1	≤ 1	350	RPM	5348	3565	2674	2139	1783	1337
					(315-385)	Fz	0.0012	0.0023	0.0030	0.0033	0.0036	0.0042
					Feed (ipm)	39	49	48	42	39	34	
		HSM 	≤ 0.05	≤ 2	450	RPM	6876	4584	3438	2750	2292	1719
					(405-495)	Fz	0.0017	0.0032	0.0042	0.0046	0.0050	0.0059
					Feed (ipm)	70	88	87	76	69	61	
STAINLESS STEELS (PH) 13-8 PH, 15-5 PH, 17-4 PH, Custom 450	≤ 325 Bhn or ≤ 35 HRc	Profile 	≤ 0.1	≤ 1	325	RPM	4966	3311	2483	1986	1655	1242
					(293-358)	Fz	0.0012	0.0023	0.0030	0.0033	0.0036	0.0042
					Feed (ipm)	36	46	45	39	36	31	
	HSM 	≤ 0.05	≤ 2	410	RPM	6265	4177	3132	2506	2088	1566	
				(369-451)	Fz	0.0017	0.0032	0.0042	0.0046	0.0050	0.0059	
				Feed (ipm)	64	80	79	69	63	55		

continued on next page

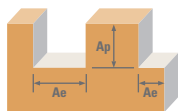

Series	Fractional	Hardness	Ae x DC	Ap x DC	Vc (sfm)	DC • in							
						1/4	3/8	1/2	5/8	3/4	1		
S	SUPER ALLOYS (NICKEL, COBALT, IRON BASE) Inconel 601, 617, 625, Incoloy, Monel 400	≤ 300 Bhn or ≤ 32 HRc	Profile 	≤ 0.1	≤ 1	105	RPM	1604	1070	802	642	535	401
						(84-126)	Fz	0.0014	0.0027	0.0036	0.0039	0.0043	0.0050
							Feed (ipm)	13	17	17	15	14	12
						130	RPM	1986	1324	993	795	662	497
						(104-156)	Fz	0.0016	0.0036	0.0048	0.0053	0.0058	0.0067
							Feed (ipm)	19	29	29	25	23	20
	SUPER ALLOYS (NICKEL, COBALT, IRON BASE) Inconel 718, X-750, Incoloy, Waspaloy, Hastelloy, Rene	≤ 400 Bhn or ≤ 43 HRc	Profile 	≤ 0.1	≤ 1	80	RPM	1222	815	611	489	407	306
						(64-96)	Fz	0.0010	0.0018	0.0025	0.0027	0.0029	0.0034
							Feed (ipm)	7	9	9	8	7	6
						100	RPM	1528	1019	764	611	509	382
						(80-120)	Fz	0.0013	0.0025	0.0034	0.0037	0.0041	0.0047
							Feed (ipm)	12	15	16	14	13	11
TITANIUM ALLOYS Pure Titanium, Ti6Al4V, Ti6Al2Sn4Zr2Mo, Ti4Al4Mo2Sn0.5Si	≤ 350 Bhn or ≤ 38 HRc	Profile 	≤ 0.1	≤ 1	280	RPM	4278	2852	2139	1711	1426	1070	
					(224-336)	Fz	0.0010	0.0018	0.0025	0.0027	0.0029	0.0034	
						Feed (ipm)	26	31	32	28	25	22	
					355	RPM	5424	3616	2712	2170	1808	1356	
					(284-426)	Fz	0.0013	0.0025	0.0034	0.0037	0.0041	0.0047	
						Feed (ipm)	42	54	55	48	44	38	
TITANIUM ALLOYS (DIFFICULT) Ti10Al2Fe3Al, Ti5Al5V5Mo3Cr, Ti7Al4Mo, Ti3Al8V6Cr4Zr4Mo, Ti6Al6V6Sn, Ti15V3 Cr3Sn3Al	≤ 440 Bhn or ≤ 47 HRc	Profile 	≤ 0.1	≤ 1	155	RPM	2368	1579	1184	947	789	592	
					(124-186)	Fz	0.0010	0.0018	0.0025	0.0027	0.0029	0.0034	
						Feed (ipm)	14	17	18	15	14	12	
					200	RPM	3056	2037	1528	1222	1019	764	
					(160-240)	Fz	0.0013	0.0025	0.0034	0.0037	0.0041	0.0047	
						Feed (ipm)	24	31	31	27	25	22	
H	TOOL STEELS A2, D2, H13, L2, M2, P20, S7, T15, W2	≤ 375 Bhn or ≤ 40 HRc	Profile 	≤ 0.1	≤ 1	240	RPM	3667	2445	1834	1467	1222	917
						(192-288)	Fz	0.0012	0.0023	0.0030	0.0034	0.0037	0.0043
							Feed (ipm)	26	34	33	30	27	24
						305	RPM	4660	3107	2330	1864	1553	1165
						(244-366)	Fz	0.0017	0.0032	0.0042	0.0046	0.0050	0.0059
							Feed (ipm)	48	60	59	51	47	41

Bhn (Brinell) HRc (Rockwell C) HSM (High Speed Machining)
 rpm = Vc x 3.82 / DC
 ipm = Fz x 6 x rpm
 reduce speed and feed for materials harder than listed
 reduce feed and Ae when finish milling (.02 x DC maximum)
 feed rates listed have chip thinning adjustments included where applicable
 refer to the SGS Tool Wizard® for complete technical information (www.kyocera-sgstool.com)

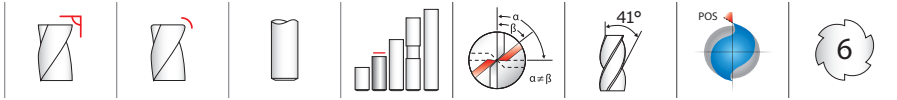

51M • 51MCR
METRIC SERIES

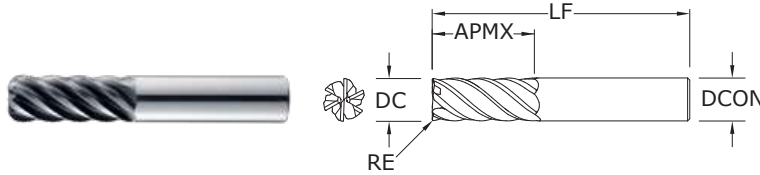

- Engineered for High Speed Milling using Trochoidal and Peel Milling techniques
- Eccentric relief provides superior strength and smoother surface finish
- Enhanced corner geometry with tight tolerance corner radii
- Recommended for materials ≤ 45 HRc (≤ 420 Bhn)

mm					EDP NO.
CUTTING DIAMETER DC	LENGTH OF CUT APMX	OVERALL LENGTH LF	SHANK DIAMETER DCON	CORNER RADIUS RE	TI-NAMITE-X (TX)
6,0	19,0	63,0	6,0	—	45100
6,0	19,0	63,0	6,0	0,5	45112
6,0	19,0	63,0	6,0	1,0	45170
6,0	19,0	63,0	6,0	1,5	45171
8,0	20,0	63,0	8,0	—	45101
8,0	20,0	63,0	8,0	0,5	45113
8,0	20,0	63,0	8,0	1,0	45114
8,0	20,0	63,0	8,0	1,2	45150
8,0	20,0	63,0	8,0	1,5	45172
8,0	20,0	63,0	8,0	2,0	45173
10,0	22,0	75,0	10,0	—	45102
10,0	22,0	75,0	10,0	0,5	45174
10,0	22,0	75,0	10,0	1,0	45115
10,0	22,0	75,0	10,0	1,5	45116
10,0	22,0	75,0	10,0	2,0	45117
10,0	22,0	75,0	10,0	2,5	45175
12,0	26,0	83,0	12,0	—	45103
12,0	26,0	83,0	12,0	0,5	45176
12,0	26,0	83,0	12,0	0,76	45177
12,0	26,0	83,0	12,0	1,0	45118
12,0	26,0	83,0	12,0	1,5	45119
12,0	26,0	83,0	12,0	2,0	45120
12,0	26,0	83,0	12,0	2,5	45178
12,0	26,0	83,0	12,0	3,0	45179
16,0	32,0	92,0	16,0	—	45104
16,0	32,0	92,0	16,0	1,0	45121
16,0	32,0	92,0	16,0	1,5	45122
16,0	32,0	92,0	16,0	2,0	45123
16,0	32,0	92,0	16,0	2,5	45180
16,0	32,0	92,0	16,0	3,0	45181
16,0	32,0	92,0	16,0	4,0	45182
20,0	38,0	104,0	20,0	—	45105
20,0	38,0	104,0	20,0	1,0	45124
20,0	38,0	104,0	20,0	1,5	45125
20,0	38,0	104,0	20,0	2,0	45126
20,0	38,0	104,0	20,0	2,5	45183
20,0	38,0	104,0	20,0	3,0	45184
20,0	38,0	104,0	20,0	4,0	45185
20,0	38,0	104,0	20,0	5,0	45186

TOLERANCES (mm)

DC = +0,000/-0,050
DCON = h_6
RE = +0,000/-0,050

- STEELS
- STAINLESS STEELS
- HIGH TEMP ALLOYS
- TITANIUM
- HARDENED STEELS

For patent information visit www.kspatents.com

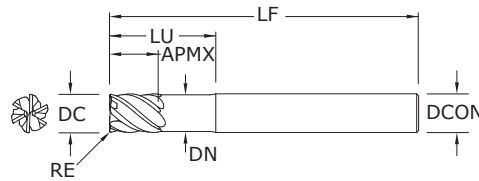
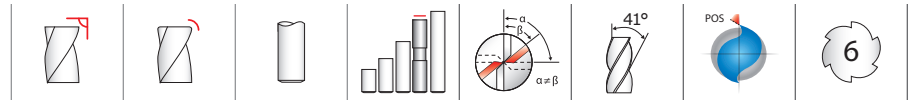

**51ML •
51MLC**
METRIC SERIES

TOLERANCES (mm)

DC = +0,000/-0,050
DCON = h₆
RE = +0,000/-0,050

- STEELS
- STAINLESS STEELS
- HIGH TEMP ALLOYS
- TITANIUM
- HARDENED STEELS

For patent information visit www.ksptpatents.com

mm							EDP NO.
CUTTING DIAMETER DC	LENGTH OF CUT APMX	OVERALL LENGTH LF	SHANK DIAMETER DCON	REACH LU	NECK DIAMETER DN	CORNER RADIUS RE	TI-NAMITE-X (TX)
6,0	8,0	75,0	6,0	32,0	5,69	—	45106
6,0	8,0	75,0	6,0	32,0	5,69	0,5	45127
6,0	8,0	75,0	6,0	32,0	5,69	1,0	45187
6,0	8,0	75,0	6,0	32,0	5,69	1,5	45188
8,0	10,0	75,0	8,0	32,0	7,59	—	45107
8,0	10,0	75,0	8,0	32,0	7,59	0,5	45128
8,0	10,0	75,0	8,0	32,0	7,59	1,0	45129
8,0	10,0	75,0	8,0	32,0	7,59	1,5	45189
8,0	10,0	75,0	8,0	32,0	7,59	2,0	45190
10,0	12,0	100,0	10,0	40,0	9,50	—	45108
10,0	12,0	100,0	10,0	40,0	9,50	0,5	45191
10,0	12,0	100,0	10,0	40,0	9,50	1,0	45130
10,0	12,0	100,0	10,0	40,0	9,50	1,5	45131
10,0	12,0	100,0	10,0	40,0	9,50	2,0	45132
10,0	12,0	100,0	10,0	40,0	9,50	2,5	45192
12,0	15,0	100,0	12,0	48,0	11,38	—	45109
12,0	15,0	100,0	12,0	48,0	11,38	0,5	45193
12,0	15,0	100,0	12,0	48,0	11,38	0,76	45194
12,0	15,0	100,0	12,0	48,0	11,38	1,0	45133
12,0	15,0	100,0	12,0	48,0	11,38	1,5	45134
12,0	15,0	100,0	12,0	48,0	11,38	2,0	45135
12,0	15,0	100,0	12,0	48,0	11,38	2,5	45195
12,0	15,0	100,0	12,0	48,0	11,38	3,0	45196
16,0	20,0	115,0	16,0	65,0	15,19	—	45110
16,0	20,0	115,0	16,0	65,0	15,19	1,0	45136
16,0	20,0	115,0	16,0	65,0	15,19	1,5	45137
16,0	20,0	115,0	16,0	65,0	15,19	2,0	45138
16,0	20,0	115,0	16,0	65,0	15,19	2,5	45197
16,0	20,0	115,0	16,0	65,0	15,19	3,0	45198
16,0	20,0	115,0	16,0	65,0	15,19	4,0	45199
20,0	24,0	150,0	20,0	80,0	19,00	—	45111
20,0	24,0	150,0	20,0	80,0	19,00	1,0	45139
20,0	24,0	150,0	20,0	80,0	19,00	1,5	45140
20,0	24,0	150,0	20,0	80,0	19,00	2,0	45141
20,0	24,0	150,0	20,0	80,0	19,00	2,5	45200
20,0	24,0	150,0	20,0	80,0	19,00	3,0	45201
20,0	24,0	150,0	20,0	80,0	19,00	4,0	45202
20,0	24,0	150,0	20,0	80,0	19,00	5,0	45203

- Engineered for High Speed Milling using Trochoidal and Peel Milling techniques
- Eccentric relief provides superior strength and smoother surface finish
- Necked design with blended diameter transitions provide clearance to reach
- Enhanced corner geometry with tight tolerance corner radii
- Recommended for materials ≤ 45 HRc (≤ 420 Bhn)

Series
51M, 51MCR,
51ML, 51MLC
Metric

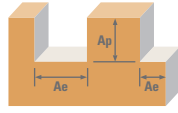

	Hardness	Ae x DC	Ap x DC	Vc (m/min)	DC • mm							
					6	8	10	12	16	20		
P	CARBON STEELS 1018, 1040, 1080, 1090, 10L50, 1140, 1212, 12L15, 1525, 1536	Profile 	≤ 0.1	≤ 1	219	RPM	11633	8725	6980	5816	4362	3490
					(176-263)	Fz	0.048	0.081	0.101	0.121	0.142	0.158
					Feed (mm/min)	3350	4240	4230	4223	3717	3308	
		HSM 	≤ 0.05	≤ 2	279	RPM	14784	11088	8870	7392	5544	4435
					(223-335)	Fz	0.066	0.113	0.141	0.169	0.197	0.220
					Feed (mm/min)	5854	7517	7504	7495	6553	5854	
	ALLOY STEELS 4140, 4150, 4320, 5120, 5150, 8630, 86L20, 50100	Profile 	≤ 0.1	≤ 1	149	RPM	7917	5938	4750	3958	2969	2375
					(119-179)	Fz	0.036	0.061	0.077	0.092	0.107	0.119
					Feed (mm/min)	1710	2173	2195	2185	1906	1696	
		HSM 	≤ 0.05	≤ 2	189	RPM	10017	7513	6010	5009	3756	3005
					(151-227)	Fz	0.049	0.083	0.104	0.125	0.146	0.163
					Feed (mm/min)	2945	3741	3750	3756	3291	2939	
M	STAINLESS STEELS (FREE MACHINING) 303, 416, 420F, 430F, 440F	Profile 	≤ 0.1	≤ 1	155	RPM	8240	6180	4944	4120	3090	2472
					(140-171)	Fz	0.035	0.060	0.075	0.090	0.105	0.117
					Feed (mm/min)	1730	2225	2225	2225	1947	1735	
		HSM 	≤ 0.05	≤ 2	198	RPM	10502	7877	6301	5251	3938	3151
					(178-218)	Fz	0.048	0.082	0.102	0.122	0.143	0.159
					Feed (mm/min)	3025	3875	3856	3844	3379	3006	
	STAINLESS STEELS (DIFFICULT) 304, 304L, 316, 316L	Profile 	≤ 0.1	≤ 1	107	RPM	5655	4241	3393	2827	2121	1696
					(96-117)	Fz	0.029	0.049	0.061	0.073	0.086	0.096
					Feed (mm/min)	984	1247	1242	1238	1094	977	
		HSM 	≤ 0.05	≤ 2	137	RPM	7271	5453	4362	3635	2726	2181
					(123-151)	Fz	0.040	0.069	0.086	0.103	0.120	0.134
					Feed (mm/min)	1745	2258	2251	2247	1963	1754	
STAINLESS STEELS (PH) 13-8 PH, 15-5 PH, 17-4 PH, Custom 450	Profile 	≤ 0.1	≤ 1	99	RPM	5251	3938	3151	2626	1969	1575	
				(89-109)	Fz	0.029	0.049	0.061	0.073	0.086	0.096	
				Feed (mm/min)	914	1158	1153	1150	1016	907		
	HSM 	≤ 0.05	≤ 2	125	RPM	6624	4968	3975	3312	2484	1987	
				(112-137)	Fz	0.040	0.069	0.086	0.103	0.120	0.134	
				Feed (mm/min)	1590	2057	2051	2047	1789	1598		

continued on next page

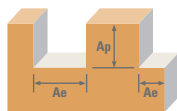

Series 51M, 51MCR, 51ML, 51MLC Metric	Hardness	Ae x DC	Ap x DC	Vc (m/min)	DC • mm							
					6	8	10	12	16	20		
SUPER ALLOYS (NICKEL, COBALT, IRON BASE) Inconel 601, 617, 625, Incoloy, Monel 400	≤ 300 Bhn or ≤ 32 HRc	Profile 	≤ 0.1	≤ 1	32	RPM	1696	1272	1018	848	636	509
					(26-38)	Fz	0.034	0.057	0.071	0.085	0.100	0.110
					Feed (mm/min)	346	435	434	433	382	336	
		HSM 	≤ 0.05	≤ 2	40	RPM	2100	1575	1260	1050	788	630
					(32-48)	Fz	0.046	0.077	0.097	0.120	0.140	0.150
					Feed (mm/min)	580	728	733	756	662	567	
	≤ 400 Bhn or ≤ 43 HRc	Profile 	≤ 0.1	≤ 1	24	RPM	1293	969	776	646	485	388
					(20-29)	Fz	0.023	0.039	0.049	0.059	0.068	0.077
					Feed (mm/min)	178	227	228	229	198	179	
		HSM 	≤ 0.05	≤ 2	30	RPM	1616	1212	969	808	606	485
					(24-37)	Fz	0.032	0.054	0.068	0.081	0.095	0.110
					Feed (mm/min)	310	393	396	393	345	320	
TITANIUM ALLOYS Pure Titanium, Ti6Al4V, Ti6Al2Sn4Zr2Mo, Ti4Al4Mo2Sn0.5Si	≤ 350 Bhn or ≤ 38 HRc	Profile 	≤ 0.1	≤ 1	85	RPM	4524	3393	2714	2262	1696	1357
					(68-102)	Fz	0.023	0.039	0.049	0.059	0.068	0.077
					Feed (mm/min)	624	794	798	801	692	627	
		HSM 	≤ 0.05	≤ 2	108	RPM	5736	4302	3441	2868	2151	1721
					(87-130)	Fz	0.032	0.054	0.068	0.081	0.095	0.110
					Feed (mm/min)	1101	1394	1404	1394	1226	1136	
TITANIUM ALLOYS (DIFFICULT) Ti10Al2Fe3Al, Ti5Al5V5Mo3Cr, Ti7Al4Mo, Ti3Al8V6Cr4Zr4Mo, Ti6Al6V6Sn, Ti15V3 Cr3Sn3Al	≤ 440 Bhn or ≤ 47 HRc	Profile 	≤ 0.1	≤ 1	47	RPM	2504	1878	1503	1252	939	751
					(38-57)	Fz	0.023	0.039	0.049	0.059	0.068	0.077
					Feed (mm/min)	346	440	442	443	383	347	
		HSM 	≤ 0.05	≤ 2	61	RPM	3231	2424	1939	1616	1212	969
					(49-73)	Fz	0.032	0.054	0.068	0.081	0.095	0.110
					Feed (mm/min)	620	785	791	785	691	640	
TOOL STEELS A2, D2, H13, L2, M2, P20, S7, T15, W2	≤ 375 Bhn or ≤ 40 HRc	Profile 	≤ 0.1	≤ 1	73	RPM	3878	2908	2327	1939	1454	1163
					(59-88)	Fz	0.029	0.049	0.061	0.073	0.086	0.096
					Feed (mm/min)	675	855	852	849	750	670	
		HSM 	≤ 0.05	≤ 2	93	RPM	4928	3696	2957	2464	1848	1478
					(74-112)	Fz	0.040	0.069	0.086	0.103	0.120	0.134
					Feed (mm/min)	1183	1530	1526	1523	1331	1189	

Bhn (Brinell) HRc (Rockwell C) HSM (High Speed Machining)
 $rpm = (Vc \times 1000) / (DC \times 3.14)$
 $mm/min = Fz \times 6 \times rpm$
 reduce speed and feed for materials harder than listed
 reduce feed and Ae when finish milling (.02 x DC maximum)
 feed rates listed have chip thinning adjustments included where applicable
 refer to the SGS Tool Wizard® for complete technical information (www.kyocera-sgstool.com)



**77 •
77CR**
FRACTIONAL SERIES

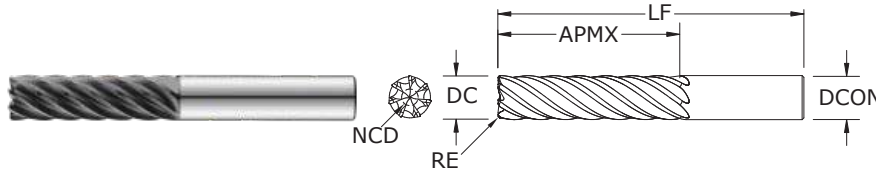

- Specializes in deep axial trochoidal and high-speed milling applications
- Optimized core improves rigidity, chip flow and reduces deflection
- Chip Breaker design breaks up chips from the long flute length allowing for better chip flow and evacuation in deep pocketing operations
- Recommended for materials ≤ 45 HRc (≤ 420 Bhn)

inch						EDP NO.			
CUTTING DIAMETER DC	LENGTH OF CUT APMX	OVERALL LENGTH LF	SHANK DIAMETER DCON	CORNER RADIUS RE	NON-CUTTING CENTER DIAMETER NCD	TI-NAMITE-A (TA) EDP NO.	TI-NAMITE-A (TA) CHIP BREAKER EDP NO.	TI-NAMITE-M (TM) EDP NO.	TI-NAMITE-M (TM) CHIP BREAKER EDP NO.
1/4	5/8	2-1/2	1/4	-	0.0845	77100	77102	77101	77103
1/4	5/8	2-1/2	1/4	.015	0.0845	77104	77106	77105	77107
1/4	5/8	2-1/2	1/4	.030	0.0845	77108	77110	77109	77111
1/4	3/4	2-1/2	1/4	-	0.0845	77112	77114	77113	77115
1/4	3/4	2-1/2	1/4	.015	0.0845	77116	77118	77117	77119
1/4	3/4	2-1/2	1/4	.030	0.0845	77120	77122	77121	77123
1/4	1	3	1/4	-	0.0845	77124	77126	77125	77127
1/4	1	3	1/4	.015	0.0845	77128	77130	77129	77131
1/4	1	3	1/4	.030	0.0845	77132	77134	77133	77135
3/8	15/16	3	3/8	-	0.1268	77136	77138	77137	77139
3/8	15/16	3	3/8	.015	0.1268	77140	77142	77141	77143
3/8	15/16	3	3/8	.030	0.1268	77144	77146	77145	77147
3/8	1-1/8	3-1/4	3/8	-	0.1268	77148	77150	77149	77151
3/8	1-1/8	3-1/4	3/8	.015	0.1268	77152	77154	77153	77155
3/8	1-1/8	3-1/4	3/8	.030	0.1268	77156	77158	77157	77159
3/8	1-1/2	3-1/2	3/8	-	0.1268	77160	77162	77161	77163
3/8	1-1/2	3-1/2	3/8	.015	0.1268	77164	77166	77165	77167
3/8	1-1/2	3-1/2	3/8	.030	0.1268	77168	77170	77169	77171
1/2	1-1/4	3-1/4	1/2	-	0.1690	77172	77174	77173	77175
1/2	1-1/4	3-1/4	1/2	.030	0.1690	77176	77178	77177	77179
1/2	1-1/4	3-1/4	1/2	.060	0.1690	77180	77182	77181	77183
1/2	1-1/2	3-1/2	1/2	-	0.1690	77184	77186	77185	77187
1/2	1-1/2	3-1/2	1/2	.030	0.1690	77188	77190	77189	77191
1/2	1-1/2	3-1/2	1/2	.060	0.1690	77192	77194	77193	77195
1/2	2	4	1/2	-	0.1690	77196	77198	77197	77199
1/2	2	4	1/2	.030	0.1690	77200	77202	77201	77203
1/2	2	4	1/2	.060	0.1690	77204	77206	77205	77207
5/8	1-9/16	3-3/4	5/8	-	0.2113	77208	77210	77209	77211
5/8	1-9/16	3-3/4	5/8	.030	0.2113	77212	77214	77213	77215
5/8	1-9/16	3-3/4	5/8	.060	0.2113	77216	77218	77217	77219

TOLERANCES (inch)

- 1/8-1/4 DIAMETER**
 DC = +0.0000/-0.0012
 DCON = h_6
 RE = +0.000/-0.002
- >1/4-3/8 DIAMETER**
 DC = +0.0000/-0.0016
 DCON = h_6
 RE = +0.000/-0.002
- >3/8-1 DIAMETER**
 DC = +0.0000/-0.0020
 DCON = h_6
 RE = +0.000/-0.002

- STEELS
- STAINLESS STEELS
- CAST IRON
- HIGH TEMP ALLOYS
- TITANIUM
- NON-FERROUS
- HARDENED STEELS

For patent information visit www.ksptpatents.com

continued on next page

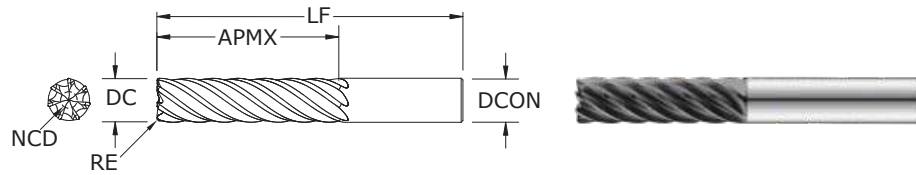

**77 •
77CR**
FRACTIONAL SERIES

TOLERANCES (inch)

1/8–1/4 DIAMETER

DC = +0.0000/-0.0012

DCON = h_6

RE = +0.000 / -0.002

>1/4–3/8 DIAMETER

DC = +0.0000/-0.0016

DCON = h_6

RE = +0.000 / -0.002

>3/8–1 DIAMETER

DC = +0.0000/-0.0020

DCON = h_6

RE = +0.000 / -0.002

- STEELS
- STAINLESS STEELS
- CAST IRON
- HIGH TEMP ALLOYS
- TITANIUM
- NON-FERROUS
- HARDENED STEELS

For patent information visit www.ksptpatents.com

inch						EDP NO.			
CUTTING DIAMETER DC	LENGTH OF CUT APMX	OVERALL LENGTH LF	SHANK DIAMETER DCON	CORNER RADIUS RE	NON-CUTTING CENTER DIAMETER NCD	TI-NAMITE-A (TA) EDP NO.	TI-NAMITE-A (TA) CHIP BREAKER EDP NO.	TI-NAMITE-M (TM) EDP NO.	TI-NAMITE-M (TM) CHIP BREAKER EDP NO.
5/8	1-7/8	4	5/8	—	0.2113	77220	77222	77221	77223
5/8	1-7/8	4	5/8	.030	0.2113	77224	77226	77225	77227
5/8	1-7/8	4	5/8	.060	0.2113	77228	77230	77229	77231
5/8	2-1/2	4-1/2	5/8	—	0.2113	77232	77234	77233	77235
5/8	2-1/2	4-1/2	5/8	.030	0.2113	77236	77238	77237	77239
5/8	2-1/2	4-1/2	5/8	.060	0.2113	77240	77242	77241	77243
3/4	1-7/8	4	3/4	—	0.2535	77244	77246	77245	77247
3/4	1-7/8	4	3/4	.030	0.2113	77248	77250	77249	77251
3/4	1-7/8	4	3/4	.060	0.2113	77252	77254	77253	77255
3/4	1-7/8	4	3/4	.120	0.2113	77256	77258	77257	77259
3/4	2-1/4	4-1/2	3/4	—	0.2535	77260	77262	77261	77263
3/4	2-1/4	4-1/2	3/4	.030	0.2535	77264	77266	77265	77267
3/4	2-1/4	4-1/2	3/4	.060	0.2535	77268	77270	77269	77271
3/4	2-1/4	4-1/2	3/4	.120	0.2535	77272	77274	77273	77275
3/4	3	5-1/4	3/4	—	0.2535	77276	77278	77277	77279
3/4	3	5-1/4	3/4	.030	0.2535	77280	77282	77281	77283
3/4	3	5-1/4	3/4	.060	0.2535	77284	77286	77285	77287
3/4	3	5-1/4	3/4	.120	0.2535	77288	77290	77289	77291
1	2-1/2	5-1/2	1	—	0.3380	77292	77294	77293	77295
1	2-1/2	5-1/2	1	.030	0.3380	77296	77298	77297	77299
1	2-1/2	5-1/2	1	.060	0.3380	77300	77302	77301	77303
1	2-1/2	5-1/2	1	.120	0.3380	77304	77306	77305	77307
1	3	6	1	—	0.3380	77308	77310	77309	77311
1	3	6	1	.030	0.3380	77312	77314	77313	77315
1	3	6	1	.060	0.3380	77316	77318	77317	77319
1	3	6	1	.120	0.3380	77320	77322	77321	77323
1	4	7	1	—	0.3380	77324	77326	77325	77327
1	4	7	1	.030	0.3380	77328	77330	77329	77331
1	4	7	1	.060	0.3380	77332	77334	77333	77335
1	4	7	1	.120	0.3380	77336	77338	77337	77339

CONTINUED



**77M •
77MCR**
METRIC SERIES

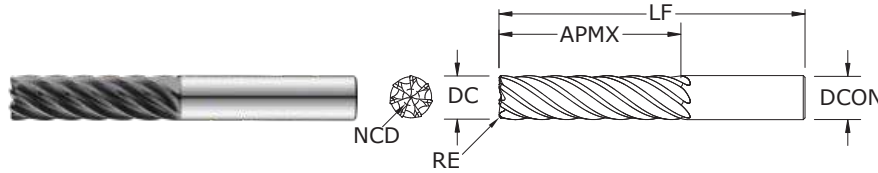

- Specializes in deep axial trochoidal and high-speed milling applications
- Optimized core improves rigidity, chip flow and reduces deflection
- Chip Breaker design breaks up chips from the long flute length allowing for better chip flow and evacuation in deep pocketing operations
- Recommended for materials ≤ 45 HRc (≤ 420 Bhn)

mm						EDP NO.			
CUTTING DIAMETER DC	LENGTH OF CUT APMX	OVERALL LENGTH LF	SHANK DIAMETER DCON	CORNER RADIUS RE	NON-CUTTING CENTER DIAMETER NCD	TI-NAMITE-A (TA) EDP NO.	TI-NAMITE-A (TA) CHIP BREAKER EDP NO.	TI-NAMITE-M (TM) EDP NO.	TI-NAMITE-M (TM) CHIP BREAKER EDP NO.
6,0	15,0	63,0	6,0	–	2,03	74300	74302	74301	74303
6,0	15,0	63,0	6,0	0,3	2,03	74304	74306	74305	74307
6,0	15,0	63,0	6,0	0,5	2,03	74308	74310	74309	74311
6,0	18,0	63,0	6,0	–	2,03	74316	74318	74317	74319
6,0	18,0	63,0	6,0	0,3	2,03	74320	74322	74321	74323
6,0	18,0	63,0	6,0	0,5	2,03	74324	74326	74325	74327
6,0	24,0	75,0	6,0	–	2,03	74332	74334	74333	74335
6,0	24,0	75,0	6,0	0,3	2,03	74336	74338	74337	74339
6,0	24,0	75,0	6,0	0,5	2,03	74340	74342	74341	74343
8,0	20,0	75,0	8,0	–	2,71	74348	74350	74349	74351
8,0	20,0	75,0	8,0	0,5	2,71	74352	74354	74353	74355
8,0	20,0	75,0	8,0	1,0	2,71	74356	74358	74357	74359
8,0	20,0	75,0	8,0	2,0	2,71	74360	74362	74361	74363
8,0	24,0	75,0	8,0	–	2,71	74364	74366	74365	74367
8,0	24,0	75,0	8,0	0,5	2,71	74368	74370	74369	74371
8,0	24,0	75,0	8,0	1,0	2,71	74372	74374	74373	74375
8,0	24,0	75,0	8,0	2,0	2,71	74376	74378	74377	74379
8,0	32,0	85,0	8,0	–	2,71	74380	74382	74381	74383
8,0	32,0	85,0	8,0	0,5	2,71	74384	74386	74385	74387
8,0	32,0	85,0	8,0	1,0	2,71	74388	74390	74389	74391
8,0	32,0	85,0	8,0	2,0	2,71	74392	74394	74393	74395
10,0	25,0	75,0	10,0	–	3,38	74396	74398	74397	74399
10,0	25,0	75,0	10,0	0,5	3,38	74400	74402	74401	74403
10,0	25,0	75,0	10,0	1,0	3,38	74404	74406	74405	74407
10,0	30,0	80,0	10,0	–	3,38	74408	74410	74409	74411
10,0	30,0	80,0	10,0	0,5	3,38	74412	74414	74413	74415
10,0	30,0	80,0	10,0	1,0	3,38	74416	74418	74417	74419
10,0	40,0	100,0	10,0	–	3,38	74420	74422	74421	74423
10,0	40,0	100,0	10,0	0,5	3,38	74424	74426	74425	74427
10,0	40,0	100,0	10,0	1,0	3,38	74428	74430	74429	74431
12,0	30,0	83,0	12,0	–	4,06	74432	74434	74433	74435
12,0	30,0	83,0	12,0	0,5	4,06	74436	74438	74437	74439
12,0	30,0	83,0	12,0	1,0	4,06	74440	74442	74441	74443
12,0	36,0	83,0	12,0	–	4,06	74444	74446	74445	74447
12,0	36,0	83,0	12,0	0,5	4,06	74448	74450	74449	74451
12,0	36,0	83,0	12,0	1,0	4,06	74452	74454	74453	74455

TOLERANCES (mm)

- 6 DIAMETER**
 DC = +0,000/-0,030
 DCON = h_6
 RE = +0,000 / -0,050
- >6-10 DIAMETER**
 DC = +0,000/-0,040
 DCON = h_6
 RE = +0,000 / -0,050
- >10-25 DIAMETER**
 DC = +0,000/-0,050
 DCON = h_6
 RE = +0,000 / -0,050

- STEELS
- STAINLESS STEELS
- CAST IRON
- HIGH TEMP ALLOYS
- TITANIUM
- NON-FERROUS
- HARDENED STEELS

For patent information visit www.ksptpatents.com

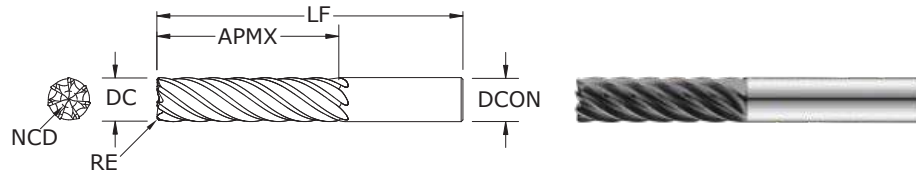

**77M •
77MCR**
METRIC SERIES

TOLERANCES (mm)

6 DIAMETER

DC = +0,000/-0,030
DCON = h₆
RE = +0,000 / -0,050

>6-10 DIAMETER

DC = +0,000/-0,040
DCON = h₆
RE = +0,000 / -0,050

>10-25 DIAMETER

DC = +0,000/-0,050
DCON = h₆
RE = +0,000 / -0,050

- STEELS
- STAINLESS STEELS
- CAST IRON
- HIGH TEMP ALLOYS
- TITANIUM
- NON-FERROUS
- HARDENED STEELS

For patent information visit www.kspatents.com

mm						EDP NO.			
CUTTING DIAMETER DC	LENGTH OF CUT APMX	OVERALL LENGTH LF	SHANK DIAMETER DCON	CORNER RADIUS RE	NON-CUTTING CENTER DIAMETER NCD	TI-NAMITE-A (TA) EDP NO.	TI-NAMITE-A (TA) CHIP BREAKER EDP NO.	TI-NAMITE-M (TM) EDP NO.	TI-NAMITE-M (TM) CHIP BREAKER EDP NO.
12,0	48,0	100,0	12,0	—	4,06	74456	74458	74457	74459
12,0	48,0	100,0	12,0	0,5	4,06	74460	74462	74461	74463
12,0	48,0	100,0	12,0	1,0	4,06	74464	74466	74465	74467
16,0	40,0	92,0	16,0	—	5,41	74468	74470	74469	74471
16,0	40,0	92,0	16,0	0,5	5,41	74472	74474	74473	74475
16,0	40,0	92,0	16,0	1,0	5,41	74476	74478	74477	74479
16,0	48,0	100,0	16,0	—	5,41	74480	74482	74481	74483
16,0	48,0	100,0	16,0	0,5	5,41	74484	74486	74485	74487
16,0	48,0	100,0	16,0	1,0	5,41	74488	74490	74489	74491
16,0	64,0	115,0	16,0	—	5,41	74492	74494	74493	74495
16,0	64,0	115,0	16,0	0,5	5,41	74496	74498	74497	74499
16,0	64,0	115,0	16,0	1,0	5,41	74500	74502	74501	74503
20,0	50,0	100,0	20,0	—	6,76	74504	74506	74505	74507
20,0	50,0	100,0	20,0	0,5	6,76	74508	74510	74509	74511
20,0	50,0	100,0	20,0	1,0	6,76	74512	74514	74513	74515
20,0	50,0	100,0	20,0	2,0	6,76	74516	74518	74517	74519
20,0	60,0	115,0	20,0	—	6,76	74520	74522	74521	74523
20,0	60,0	115,0	20,0	0,5	6,76	74524	74526	74525	74527
20,0	60,0	115,0	20,0	1,0	6,76	74528	74530	74529	74531
20,0	60,0	115,0	20,0	2,0	6,76	74532	74534	74533	74535
20,0	80,0	140,0	20,0	—	6,76	74536	74538	74537	74539
20,0	80,0	140,0	20,0	0,5	6,76	74540	74542	74541	74543
20,0	80,0	140,0	20,0	1,0	6,76	74544	74546	74545	74547
20,0	80,0	140,0	20,0	2,0	6,76	74548	74550	74549	74551
25,0	63,0	135,0	25,0	—	8,45	74552	74554	74553	74555
25,0	63,0	135,0	25,0	1,0	8,45	74556	74558	74557	74559
25,0	63,0	135,0	25,0	2,0	8,45	74560	74562	74561	74563
25,0	63,0	135,0	25,0	3,0	8,45	74564	74566	74565	74567
25,0	75,0	150,0	25,0	—	8,45	74568	74570	74569	74571
25,0	75,0	150,0	25,0	1,0	8,45	74572	74574	74573	74575
25,0	75,0	150,0	25,0	2,0	8,45	74576	74578	74577	74579
25,0	75,0	150,0	25,0	3,0	8,45	74580	74582	74581	74583
25,0	100,0	170,0	25,0	—	8,45	74584	74586	74585	74587
25,0	100,0	170,0	25,0	1,0	8,45	74588	74590	74589	74591
25,0	100,0	170,0	25,0	2,0	8,45	74592	74594	74593	74595
25,0	100,0	170,0	25,0	3,0	8,45	74596	74598	74597	74599

CONTINUED

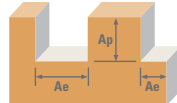

Series 77, 77CR Fractional	Hardness	Ae x D ₁	Ap x D ₁	Vc (sfm)	D ₁ • inch						
					1/4	3/8	1/2	5/8	3/4	1	
P CARBON STEELS 1018, 1040, 1080, 1090, 10L50, 1140, 1212, 12L15, 1525, 1536	≤ 275 Bhn or ≤ 28 HRc	HSM	2.5xD	816	RPM	11552	7701	5776	4621	3851	2888
			≤ 0.2 ≤ APMX (653-979)	Fz	0.0015	0.0024	0.0031	0.0035	0.0038	0.0042	
		HSM	3xD	845	Fz	0.0017	0.0027	0.0035	0.0040	0.0043	0.0047
			≤ 0.15 ≤ APMX (676-1014)	Feed (ipm)	121	129	125	113	102	85	
		HSM	4xD	756	Fz	0.0018	0.0028	0.0036	0.0041	0.0044	0.0049
			≤ 0.1 ≤ APMX (605-907)	Feed (ipm)	136	146	140	129	116	95	
	≤ 375 Bhn or ≤ 40 HRc	HSM	2.5xD	595	RPM	8419	5613	4210	3368	2806	2105
			≤ 0.2 ≤ APMX (476-714)	Fz	0.0009	0.0019	0.0026	0.0028	0.0031	0.0035	
		HSM	3xD	616	Fz	0.0010	0.0021	0.0030	0.0033	0.0035	0.0039
			≤ 0.15 ≤ APMX (493-739)	Feed (ipm)	53	75	77	66	61	52	
		HSM	4xD	551	Fz	0.0011	0.0022	0.0031	0.0034	0.0036	0.0041
			≤ 0.1 ≤ APMX (441-661)	Feed (ipm)	59	83	88	78	69	57	
M STAINLESS STEELS (FREE MACHINING) 303, 416, 420F, 430F, 440F	≤ 275 Bhn or ≤ 28 HRc	HSM	2.5xD	646	RPM	9137	6092	4569	3655	3046	2284
			≤ 0.2 ≤ APMX (517-775)	Fz	0.0009	0.0017	0.0023	0.0025	0.0028	0.0032	
		HSM	3xD	669	Fz	0.0010	0.0019	0.0026	0.0029	0.0031	0.0036
			≤ 0.15 ≤ APMX (535-803)	Feed (ipm)	64	81	83	74	66	58	
		HSM	4xD	598	Fz	0.0011	0.0020	0.0027	0.0030	0.0033	0.0037
			≤ 0.1 ≤ APMX (478-718)	Feed (ipm)	70	85	86	77	70	59	
	≤ 275 Bhn or ≤ 28 HRc	HSM	2.5xD	425	RPM	6020	4014	3010	2408	2007	1505
			≤ 0.2 ≤ APMX (340-510)	Fz	0.0007	0.0014	0.0019	0.0023	0.0026	0.0030	
		HSM	3xD	440	Fz	0.0008	0.0016	0.0021	0.0025	0.0029	0.0034
			≤ 0.15 ≤ APMX (352-528)	Feed (ipm)	29	39	40	39	37	32	
		HSM	4xD	394	Fz	0.0008	0.0016	0.0022	0.0026	0.0030	0.0035
			≤ 0.1 ≤ APMX (315-473)	Feed (ipm)	34	45	44	42	41	36	
≤ 325 Bhn or ≤ 35 HRc	HSM	2.5xD	408	RPM	5776	3851	2888	2310	1925	1444	
		≤ 0.2 ≤ APMX (326-490)	Fz	0.0007	0.0014	0.0019	0.0023	0.0026	0.0030		
	HSM	3xD	422	Fz	0.0008	0.0016	0.0021	0.0025	0.0029	0.0034	
		≤ 0.15 ≤ APMX (338-506)	Feed (ipm)	28	38	38	37	35	30		
	HSM	4xD	378	Fz	0.0008	0.0016	0.0022	0.0026	0.0030	0.0035	
		≤ 0.1 ≤ APMX (302-454)	Feed (ipm)	32	43	42	40	39	34		
P CAST IRONS (LOW & MEDIUM ALLOY) Gray, Malleable, Ductile	≤ 220 Bhn or ≤ 19 HRc	HSM	2.5xD	714	RPM	10100	6733	5050	4040	3367	2525
			≤ 0.2 ≤ APMX (571-857)	Fz	0.0010	0.0018	0.0024	0.0028	0.0033	0.0037	
		HSM	3xD	739	Fz	0.0011	0.0020	0.0027	0.0033	0.0037	0.0042
			≤ 0.15 ≤ APMX (591-887)	Feed (ipm)	71	85	85	79	78	65	
		HSM	4xD	661	Fz	0.0012	0.0021	0.0028	0.0034	0.0039	0.0043
			≤ 0.1 ≤ APMX (529-793)	Feed (ipm)	78	94	95	93	87	73	
	≤ 260 Bhn or ≤ 26 HRc	HSM	2.5xD	425	RPM	6020	4014	3010	2408	2007	1505
			≤ 0.2 ≤ APMX (340-510)	Fz	0.0007	0.0014	0.0019	0.0023	0.0026	0.0030	
		HSM	3xD	440	Fz	0.0008	0.0016	0.0021	0.0025	0.0029	0.0037
			≤ 0.15 ≤ APMX (352-528)	Feed (ipm)	34	45	44	42	41	39	
		HSM	4xD	394	Fz	0.0008	0.0016	0.0022	0.0026	0.0030	0.0035
			≤ 0.1 ≤ APMX (315-473)	Feed (ipm)	34	45	46	44	42	37	
CAST IRONS (HIGH ALLOY) Gray, Malleable, Ductile	≤ 260 Bhn or ≤ 26 HRc	HSM	2.5xD	425	RPM	6020	4014	3010	2408	2007	1505
			≤ 0.2 ≤ APMX (340-510)	Fz	0.0007	0.0014	0.0019	0.0023	0.0026	0.0030	
		HSM	3xD	440	Fz	0.0008	0.0016	0.0021	0.0025	0.0029	0.0037
			≤ 0.15 ≤ APMX (352-528)	Feed (ipm)	29	39	40	39	37	32	
		HSM	4xD	394	Fz	0.0008	0.0016	0.0022	0.0026	0.0030	0.0035
			≤ 0.1 ≤ APMX (315-473)	Feed (ipm)	34	45	44	42	41	39	

continued on next page

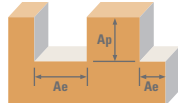

	Series 77, 77CR Fractional	Hardness	Ae x D ₁	Ap x D ₁	Vc (sfm)	D ₁ • inch							
						1/4	3/8	1/2	5/8	3/4	1		
N NON-FERROUS MATERIALS	Not Recommended for this Material Group												
	SUPER ALLOYS (NICKEL, COBALT, IRON BASE) Inconel 601, 617, 625, Incoloy, Monel 400	≤ 300 Bhn or ≤ 32 HRc	HSM	2.5xD	136	RPM	1925	1284	963	770	642	481	
				≤ 0.2	≤ APMX	(109-163)	Fz	0.0006	0.0011	0.0016	0.0018	0.0021	0.0025
				Feed (ipm)	8	10	11	10	9	8			
		HSM	3xD	141	Fz	0.0007	0.0012	0.0018	0.0021	0.0024	0.0028		
				≤ 0.15	≤ APMX	(113-169)	Feed (ipm)	9	11	12	11	11	9
				HSM	4xD	126	Fz	0.0007	0.0013	0.0018	0.0022	0.0025	0.0029
	SUPER ALLOYS (NICKEL, COBALT, IRON BASE) Inconel 718, X-750, Incoloy, Waspaloy, Hastelloy, Rene	≤ 400 Bhn or ≤ 43 HRc	HSM	2.5xD	85	RPM	1207	805	604	483	402	302	
				≤ 0.2	≤ APMX	(68-102)	Fz	0.0005	0.0009	0.0013	0.0015	0.0018	0.0022
				Feed (ipm)	4	5	5	5	5	5			
		HSM	3xD	88	Fz	0.0005	0.0010	0.0015	0.0018	0.0020	0.0025		
				≤ 0.15	≤ APMX	(70-106)	Feed (ipm)	4	6	6	6	6	5
HSM				4xD	79	Fz	0.0006	0.0011	0.0015	0.0018	0.0021	0.0026	
TITANIUM ALLOYS Pure Titanium, Ti6Al4V, Ti6Al2Sn4Zr2Mo, Ti4Al4Mo2Sn0.5Si	≤ 350 Bhn or ≤ 38 HRc	HSM	2.5xD	289	RPM	4095	2730	2048	1638	1365	1024		
			≤ 0.2	≤ APMX	(231-347)	Fz	0.0008	0.0015	0.0021	0.0024	0.0028	0.0032	
			Feed (ipm)	23	29	30	28	27	23				
	HSM	3xD	299	Fz	0.0009	0.0017	0.0023	0.0025	0.0028	0.0036			
			≤ 0.15	≤ APMX	(239-359)	Feed (ipm)	26	32	33	29	27	26	
			HSM	4xD	268	Fz	0.0009	0.0018	0.0024	0.0029	0.0033	0.0037	
TITANIUM ALLOYS (DIFFICULT) Ti10Al2Fe3Al, Ti5Al5V5Mo3Cr, Ti7Al4Mo, Ti3Al8V6Cr4Zr4Mo, Ti6Al6V6Sn, Ti15V3 Cr3Sn3Al	≤ 440 Bhn or ≤ 47 HRc	HSM	2.5xD	170	RPM	2399	1599	1199	960	800	600		
			≤ 0.2	≤ APMX	(136-204)	Fz	0.0008	0.0015	0.0021	0.0024	0.0028	0.0032	
			Feed (ipm)	13	17	18	16	16	13				
	HSM	3xD	176	Fz	0.0009	0.0017	0.0023	0.0025	0.0028	0.0036			
			≤ 0.15	≤ APMX	(141-211)	Feed (ipm)	15	19	19	17	16	15	
			HSM	4xD	157	Fz	0.0009	0.0018	0.0024	0.0029	0.0033	0.0037	
TOOL STEELS A2, D2, H13, L2, M2, P20, S7, T15, W2	≤ 375 Bhn or ≤ 40 HRc	HSM	2.5xD	272	RPM	3851	2567	1925	1540	1284	963		
			≤ 0.2	≤ APMX	(218-326)	Fz	0.0006	0.0011	0.0014	0.0017	0.0020	0.0024	
			Feed (ipm)	16	20	19	18	18	16				
	HSM	3xD	282	Fz	0.0007	0.0012	0.0016	0.0019	0.0022	0.0027			
			≤ 0.15	≤ APMX	(226-338)	Feed (ipm)	19	22	22	20	20	18	
			HSM	4xD	252	Fz	0.0007	0.0013	0.0017	0.0020	0.0023	0.0028	
	≤ 0.1	≤ APMX	(202-302)	Feed (ipm)	19	23	23	22	21	19			

Bhn (Brinell) HRc (Rockwell C) HSM (High Speed Machining)
 rpm = Vc x 3.82 / DC
 mm/min = Fz x 7 x rpm
 reduce speed and feed for materials harder than listed
 reduce feed and Ae when finish milling (.02 x DC maximum)
 feed rates listed have chip thinning adjustments included where applicable
 refer to the SGS Tool Wizard® for complete technical information (www.kyocera-sgstool.com)

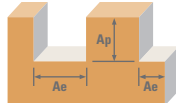

Series 77M, 77MCR Metric	Hardness	Ae x D ₁	Ap x D ₁	Vc (m/min)	D ₁ • mm							
					6	8	10	12	16	20	25	
P CARBON STEELS 1018, 1040, 1080, 1090, 10L50, 1140, 1212, 12L15, 1525, 1536	≤ 275 Bhn or ≤ 28 HRC	HSM	2.5xD	284	RPM	12208	9156	7325	6104	4578	3662	2930
			≤ 0.2 ≤ APMX	(227-341)	Fz	0.0413	0.0411	0.0640	0.0711	0.0889	0.1013	0.1050
		HSM	3xD	257	Feed (ipm)	3529	2634	3282	3038	2849	2597	2154
			≤ 0.15 ≤ APMX	(206-308)	Fz	0.0347	0.0461	0.0717	0.0797	0.0996	0.1135	0.1176
		HSM	4xD	230	Feed (ipm)	2965	2955	3676	3405	3192	2910	2412
			≤ 0.1 ≤ APMX	(184-276)	Fz	0.0362	0.0480	0.0747	0.0830	0.1037	0.1182	0.0919
	≤ 375 Bhn or ≤ 40 HRC	HSM	2.5xD	132	RPM	8068	6051	4841	4034	3025	2420	1936
			≤ 0.2 ≤ APMX	(106-159)	Fz	0.0213	0.0285	0.0512	0.0610	0.0711	0.0827	0.0875
		HSM	3xD	138	Feed (ipm)	1203	1207	1735	1723	1506	1401	1186
			≤ 0.15 ≤ APMX	(111-166)	Fz	0.0239	0.0319	0.0574	0.0683	0.0797	0.0926	0.0980
		HSM	4xD	152	Feed (ipm)	1350	1351	1945	1929	1688	1569	1328
			≤ 0.1 ≤ APMX	(122-182)	Fz	0.0249	0.0332	0.0597	0.0711	0.0830	0.0964	0.1021
M STAINLESS STEELS (FREE MACHINING) 303, 416, 420F, 430F, 440F	≤ 275 Bhn or ≤ 28 HRC	HSM	2.5xD	197	RPM	9660	7245	5796	4830	3623	2898	2318
			≤ 0.2 ≤ APMX	(158-236)	Fz	0.0216	0.0285	0.0448	0.0533	0.0635	0.0747	0.0800
		HSM	3xD	204	Feed (ipm)	1461	1445	1818	1803	1610	1515	1298
			≤ 0.15 ≤ APMX	(163-245)	Fz	0.0242	0.0319	0.0502	0.0598	0.0711	0.0837	0.0896
		HSM	4xD	182	Feed (ipm)	1636	1618	2037	2022	1803	1698	1454
			≤ 0.1 ≤ APMX	(146-218)	Fz	0.0252	0.0332	0.0523	0.0622	0.0741	0.0871	0.0933
	≤ 275 Bhn or ≤ 28 HRC	HSM	2.5xD	130	RPM	6369	4777	3822	3185	2389	1911	1529
			≤ 0.2 ≤ APMX	(104-156)	Fz	0.0168	0.0221	0.0371	0.0432	0.0584	0.0693	0.0750
		HSM	3xD	134	Feed (ipm)	749	739	993	963	976	927	803
			≤ 0.15 ≤ APMX	(107-161)	Fz	0.0188	0.0248	0.0416	0.0484	0.0655	0.0777	0.0840
		HSM	4xD	120	Feed (ipm)	838	829	1113	1079	1095	1039	899
			≤ 0.1 ≤ APMX	(96-144)	Fz	0.0196	0.0258	0.0433	0.0504	0.0682	0.0809	0.0875
≤ 325 Bhn or ≤ 35 HRC	HSM	2.5xD	124	RPM	6104	4578	3662	3052	2289	1831	1465	
		≤ 0.2 ≤ APMX	(99-149)	Fz	0.0168	0.0221	0.0371	0.0432	0.0584	0.0693	0.0750	
	HSM	3xD	129	Feed (ipm)	718	708	952	923	936	888	769	
		≤ 0.15 ≤ APMX	(103-155)	Fz	0.0188	0.0248	0.0416	0.0484	0.0655	0.0777	0.0840	
	HSM	4xD	115	Feed (ipm)	803	795	1066	1034	1050	996	861	
		≤ 0.1 ≤ APMX	(92-138)	Fz	0.0196	0.0258	0.0433	0.0504	0.0682	0.0809	0.0875	
P CAST IRONS (LOW & MEDIUM ALLOY) Gray, Malleable, Ductile	≤ 220 Bhn or ≤ 19 HRC	HSM	2.5xD	218	RPM	10722	8041	6433	5361	4021	3217	2573
			≤ 0.2 ≤ APMX	(174-262)	Fz	0.0239	0.0315	0.0474	0.0559	0.0762	0.0880	0.0925
		HSM	3xD	225	Feed (ipm)	1794	1773	2135	2098	2145	1981	1666
			≤ 0.15 ≤ APMX	(180-270)	Fz	0.0268	0.0353	0.0531	0.0626	0.0854	0.0986	0.1036
		HSM	4xD	202	Feed (ipm)	2011	1987	2391	2349	2404	2220	1866
			≤ 0.1 ≤ APMX	(162-242)	Fz	0.0279	0.0368	0.0553	0.0652	0.0889	0.1027	0.1079
	≤ 260 Bhn or ≤ 26 HRC	HSM	2.5xD	130	RPM	6369	4777	3822	3185	2389	1911	1529
			≤ 0.2 ≤ APMX	(104-156)	Fz	0.0168	0.0221	0.0371	0.0432	0.0584	0.0693	0.0750
		HSM	3xD	134	Feed (ipm)	749	739	993	963	976	927	803
			≤ 0.15 ≤ APMX	(107-161)	Fz	0.0188	0.0248	0.0416	0.0484	0.0655	0.0777	0.0840
		HSM	4xD	120	Feed (ipm)	838	829	1113	1079	1095	1039	899
			≤ 0.1 ≤ APMX	(96-144)	Fz	0.0196	0.0258	0.0433	0.0504	0.0682	0.0809	0.0875
N NON-FERROUS MATERIALS	Not Recommended for this Material Group											

continued on next page

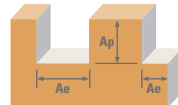

Series 77M, 77MCR Metric	Hardness	Ae x D ₁	Ap x D ₁	Vc (m/min)	D ₁ • mm							
					6	8	10	12	16	20	25	
SUPER ALLOYS (NICKEL, COBALT, IRON BASE) Inconel 601, 617, 625, Incoloy, Monel 400	≤ 300 Bhn or ≤ 32 HRc	HSM	2.5xD	41 (33-49)	RPM							
					Fz	2017	1513	1210	1008	756	605	484
		Feed (ipm)	198	194	249	251	242	237	212			
		HSM	3xD	43 (34-52)	Fz	0.0157	0.0205	0.0330	0.0398	0.0512	0.0627	0.0700
					Feed (ipm)	222	217	280	281	271	266	237
		HSM	4xD	38 (30-46)	Fz	0.0163	0.0213	0.0344	0.0415	0.0533	0.0653	0.0729
	Feed (ipm)				230	226	291	293	282	277	247	
	≤ 400 Bhn or ≤ 43 HRc	HSM	2.5xD	26 (21-31)	RPM							
					Fz	1274	955	764	637	478	382	306
		Feed (ipm)	102	102	130	136	127	128	118			
		HSM	3xD	27 (22-32)	Fz	0.0128	0.0171	0.0273	0.0342	0.0427	0.0538	0.0616
					Feed (ipm)	114	114	146	152	143	144	132
HSM		4xD	24 (19-29)	Fz	0.0133	0.0178	0.0284	0.0356	0.0445	0.0560	0.0642	
	Feed (ipm)			119	119	152	159	149	150	137		
TITANIUM ALLOYS Pure Titanium, Ti6Al4V, Ti6Al2Sn4Zr2Mo, Ti4Al4Mo2Sn0.5Si	≤ 350 Bhn or ≤ 38 HRc	HSM	2.5xD	88 (70-106)	RPM							
					Fz	4352	3264	2611	2176	1632	1306	1045
		Feed (ipm)	582	580	726	736	725	683	585			
		HSM	3xD	91 (73-109)	Fz	0.0213	0.0285	0.0445	0.0541	0.0711	0.0837	0.0896
					Feed (ipm)	649	651	813	824	812	765	655
		HSM	4xD	82 (66-98)	Fz	0.0222	0.0296	0.0463	0.0563	0.0741	0.0871	0.0933
	Feed (ipm)				676	676	846	858	847	796	682	
	≤ 440 Bhn or ≤ 47 HRc	HSM	2.5xD	52 (42-62)	RPM							
					Fz	2548	1911	1529	1274	955	764	611
		Feed (ipm)	291	340	425	431	425	400	342			
		HSM	3xD	54 (43-65)	Fz	0.0182	0.0285	0.0445	0.0541	0.0711	0.0837	0.0896
					Feed (ipm)	325	381	476	482	476	448	384
HSM		4xD	48 (38-58)	Fz	0.0190	0.0296	0.0463	0.0563	0.0741	0.0871	0.0933	
	Feed (ipm)			339	396	495	502	496	466	399		
TOOL STEELS A2, D2, H13, L2, M2, P20, S7, T15, W2	≤ 375 Bhn or ≤ 40 HRc	HSM	2.5xD	83 (66-100)	RPM							
					Fz	4087	3065	2452	2044	1533	1226	981
		Feed (ipm)	401	393	505	509	490	481	429			
		HSM	3xD	86 (69-103)	Fz	0.0157	0.0205	0.0330	0.0398	0.0512	0.0627	0.0700
					Feed (ipm)	449	440	566	569	549	538	481
		HSM	4xD	77 (62-92)	Fz	0.0163	0.0213	0.0344	0.0415	0.0533	0.0653	0.0729
	Feed (ipm)				466	457	590	594	572	560	501	

Bhn (Brinell) HRc (Rockwell C) HSM (High Speed Machining)
 rpm = (Vc x 1000) / (DC x 3.14)
 mm/min = Fz x 7 x rpm
 reduce speed and feed for materials harder than listed
 reduce feed and Ae when finish milling (.02 x DC maximum)
 feed rates listed have chip thinning adjustments included where applicable
 refer to the SGS Tool Wizard® for complete technical information (www.kyocera-sgtool.com)

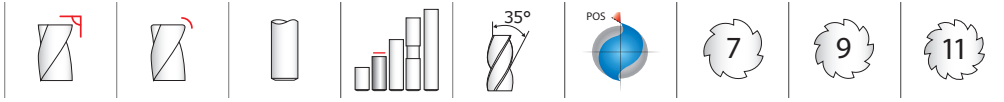

**66 •
66CR**
FRACTIONAL SERIES

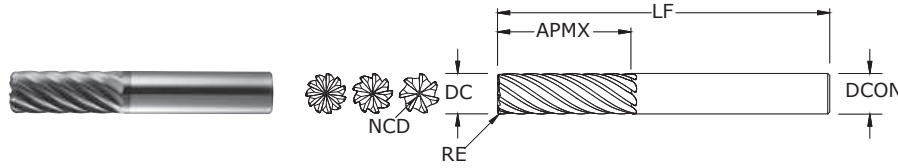

- Heavy core and rigid design allow for straight walls
- High flute count design results in smoother cutting performance and enhanced tool life in precise finishing applications
- Enhanced corner geometry with tight tolerance corner radii
- Recommended for materials ≤ 45 HRc (≤ 420 Bhn)

inch							EDP NO.
CUTTING DIAMETER DC	LENGTH OF CUT APMX	OVERALL LENGTH LF	SHANK DIAMETER DCON	CORNER RADIUS RE	NON-CUTTING CENTER DIAMETER NCD	NO. OF FLUTES	TI-NAMITE-X
3/16	5/8	2	3/16	—	0.0550	7	36620
3/16	5/8	2	3/16	.010	0.0550	7	36627
1/4	3/4	2-1/2	1/4	—	0.0650	7	36621
1/4	3/4	2-1/2	1/4	.015	0.0650	7	36628
3/8	1	3	3/8	—	0.0810	7	36622
3/8	1	3	3/8	.015	0.0810	7	36629
1/2	1-1/4	3	1/2	—	0.1340	9	36623
1/2	1-1/4	3	1/2	.030	0.1340	9	36630
1/2	1-1/4	3	1/2	.090	0.1340	9	36631
1/2	1-1/4	3	1/2	.120	0.1340	9	36632
5/8	1-5/8	3-1/2	5/8	—	0.1150	9	36624
5/8	1-5/8	3-1/2	5/8	.030	0.1150	9	36633
5/8	1-5/8	3-1/2	5/8	.090	0.1150	9	36634
5/8	1-5/8	3-1/2	5/8	.120	0.1150	9	36635
3/4	1-5/8	4	3/4	—	0.1750	11	36625
3/4	1-5/8	4	3/4	.030	0.1750	11	36636
3/4	1-5/8	4	3/4	.090	0.1750	11	36637
3/4	1-5/8	4	3/4	.120	0.1750	11	36638
1	2	6	1	—	0.3000	11	36626
1	2	6	1	.030	0.3000	11	36639
1	2	6	1	.090	0.3000	11	36640
1	2	6	1	.120	0.3000	11	36641

Neck Option Available

TOLERANCES (inch)

DC = +0.0000/-0.0020
DCON = h_6
RE = +0.0000/-0.0020

- STEELS
- STAINLESS STEELS
- CAST IRON
- HIGH TEMP ALLOYS
- TITANIUM
- HARDENED STEELS

For patent information visit www.ksptpatents.com

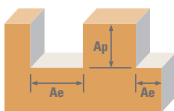

Series	Hardness	Ae x DC	Ap x DC	Vc (sfm)	DC • in								
					3/16	1/4	3/8	1/2	5/8	3/4	1		
Series 66, 66CR Fractional CARBON STEELS 1018, 1040, 1080, 1090, 10L50, 1140, 1212, 12L15, 1525, 1536 ALLOY STEELS 4140, 4150, 4320, 5120, 5150, 8630, 86L20, 50100	≤ 275 Bhn or ≤ 28 HRc	Profile	≤ 0.05	≤ 1	635	RPM	12937	9703	6469	4851	3881	3234	2426
					(508-762)	Fz	0.0008	0.0012	0.0022	0.0030	0.0037	0.0038	0.0042
					Feed (ipm)	72.4	81.5	99.6	131.0	129.2	135.2	112.1	
		Finish	≤ 0.02	≤ 2	762	RPM	15524	11643	7762	5822	4657	3881	2911
					(610-914)	Fz	0.0006	0.0010	0.0018	0.0024	0.0030	0.0030	0.0034
					Feed (ipm)	69.5	78.2	95.6	125.7	124.1	129.8	107.6	
	≤ 375 Bhn or ≤ 40 HRc	Profile	≤ 0.05	≤ 1	360	RPM	7334	5501	3667	2750	2200	1834	1375
					(288-432)	Fz	0.0006	0.0009	0.0017	0.0023	0.0029	0.0030	0.0032
					Feed (ipm)	30.8	34.7	43.6	56.9	57.4	60.5	48.4	
		Finish	≤ 0.02	≤ 2	432	RPM	8801	6601	4401	3300	2640	2200	1650
					(346-518)	Fz	0.0005	0.0007	0.0014	0.0018	0.0023	0.0024	0.0026
					Feed (ipm)	29.6	33.3	41.9	54.7	55.1	58.1	46.5	
STAINLESS STEELS (FREE MACHINING) 303, 416, 420F, 430F, 440F STAINLESS STEELS (DIFFICULT) 304, 304L, 316, 316L STAINLESS STEELS (PH) 13-8 PH, 15-5 PH, 17-4 PH, Custom 450 CAST IRONS (LOW & MEDIUM ALLOY) Gray, Malleable, Ductile	≤ 275 Bhn or ≤ 28 HRc	Profile	≤ 0.05	≤ 1	560	RPM	11409	8557	5705	4278	3423	2852	2139
					(448-672)	Fz	0.0006	0.0009	0.0017	0.0023	0.0029	0.0030	0.0032
					Feed (ipm)	47.9	53.9	67.9	88.6	89.3	94.1	75.3	
		Finish	≤ 0.02	≤ 2	448	RPM	9127	6845	4564	3423	2738	2282	1711
					(358-538)	Fz	0.0005	0.0007	0.0014	0.0018	0.0023	0.0024	0.0026
					Feed (ipm)	30.7	34.5	43.4	56.7	57.2	60.2	48.2	
	≤ 275 Bhn or ≤ 28 HRc	Profile	≤ 0.05	≤ 1	385	RPM	7844	5883	3922	2941	2353	1961	1471
					(308-462)	Fz	0.0005	0.0007	0.0014	0.0018	0.0023	0.0024	0.0026
					Feed (ipm)	27.5	28.8	38.4	47.7	48.7	51.8	42.1	
		Finish	≤ 0.02	≤ 2	462	RPM	9412	7059	4706	3530	2824	2353	1765
					(370-554)	Fz	0.0004	0.0006	0.0011	0.0014	0.0018	0.0019	0.0021
					Feed (ipm)	26.4	27.7	36.9	45.7	46.8	49.7	40.4	
≤ 325 Bhn or ≤ 35 HRc	Profile	≤ 0.05	≤ 1	355	RPM	7233	5424	3616	2712	2170	1808	1356	
				(284-426)	Fz	0.0005	0.0007	0.0014	0.0018	0.0023	0.0024	0.0026	
				Feed (ipm)	25.3	26.6	35.4	43.9	44.9	47.7	38.8		
	Finish	≤ 0.02	≤ 2	426	RPM	8679	6509	4340	3255	2604	2170	1627	
				(341-511)	Fz	0.0004	0.0006	0.0011	0.0014	0.0018	0.0019	0.0021	
				Feed (ipm)	24.3	25.5	34.0	42.2	43.1	45.8	37.2		
≤ 220 Bhn or ≤ 19 HRc	Profile	≤ 0.05	≤ 1	705	RPM	14363	10772	7182	5386	4309	3591	2693	
				(564-846)	Fz	0.0008	0.0012	0.0022	0.0030	0.0037	0.0038	0.0042	
				Feed (ipm)	80.4	90.5	110.6	145.4	143.5	150.1	124.4		
	Finish	≤ 0.02	≤ 2	846	RPM	17236	12927	8618	6463	5171	4309	3232	
				(677-1015)	Fz	0.0006	0.0010	0.0018	0.0024	0.0030	0.0030	0.0034	
				Feed (ipm)	77.2	86.9	106.2	139.6	137.7	144.1	119.4		

continued on next page

FRACTIONAL Multi-Carb

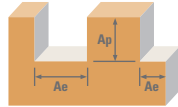

Series 66, 66CR Fractional	Hardness	Ae x DC	Ap x DC	Vc (sfm)	DC • in								
					3/16	1/4	3/8	1/2	5/8	3/4	1		
K CAST IRONS (HIGH ALLOY) Gray, Malleable, Ductile	≤ 260 Bhn or ≤ 26 HRc	Profile 	≤ 0.05	≤ 1	540	RPM	11002	8251	5501	4126	3300	2750	2063
					(432-648)	Fz	0.0006	0.0009	0.0017	0.0023	0.0029	0.0030	0.0032
					648	RPM	13202	9901	6601	4951	3961	3300	2475
		Finish 	≤ 0.02	≤ 2	(518-778)	Fz	0.0005	0.0007	0.0014	0.0018	0.0023	0.0024	0.0026
					648	RPM	13202	9901	6601	4951	3961	3300	2475
					648	RPM	13202	9901	6601	4951	3961	3300	2475
S SUPER ALLOYS (NICKEL, COBALT, IRON BASE) Inconel 601, 617, 625, Incoloy, Monel 400	≤ 300 Bhn or ≤ 32 HRc	Profile 	≤ 0.05	≤ 1	105	RPM	2139	1604	1070	802	642	535	401
					(84-126)	Fz	0.0005	0.0007	0.0014	0.0018	0.0023	0.0024	0.0026
					126	RPM	2567	1925	1284	963	770	642	481
		Finish 	≤ 0.02	≤ 2	(101-151)	Fz	0.0004	0.0006	0.0011	0.0014	0.0018	0.0019	0.0021
					126	RPM	2567	1925	1284	963	770	642	481
					126	RPM	2567	1925	1284	963	770	642	481
S SUPER ALLOYS (NICKEL, COBALT, IRON BASE) Inconel 718, X-750, Incoloy, Waspaloy, Hastelloy, Rene	≤ 400 Bhn or ≤ 43 HRc	Profile 	≤ 0.05	≤ 1	85	RPM	1732	1299	866	649	520	433	325
					(68-102)	Fz	0.0003	0.0005	0.0009	0.0011	0.0014	0.0015	0.0016
					102	RPM	2078	1559	1039	779	623	520	390
		Finish 	≤ 0.02	≤ 2	(82-122)	Fz	0.0002	0.0004	0.0007	0.0009	0.0011	0.0012	0.0013
					102	RPM	2078	1559	1039	779	623	520	390
					102	RPM	2078	1559	1039	779	623	520	390
S TITANIUM ALLOYS Pure Titanium, Ti6Al4V, Ti6Al2Sn4Zr2Mo, Ti4Al4Mo2Sn0.5Si	≤ 350 Bhn or ≤ 38 HRc	Profile 	≤ 0.05	≤ 1	390	RPM	7946	5959	3973	2980	2384	1986	1490
					(312-468)	Fz	0.0005	0.0008	0.0015	0.0021	0.0026	0.0027	0.0029
					468	RPM	9535	7151	4767	3576	2860	2384	1788
		Finish 	≤ 0.02	≤ 2	(374-562)	Fz	0.0004	0.0006	0.0012	0.0017	0.0021	0.0022	0.0023
					468	RPM	9535	7151	4767	3576	2860	2384	1788
					468	RPM	9535	7151	4767	3576	2860	2384	1788
S TITANIUM ALLOYS (DIFFICULT) Ti10Al2Fe3Al, Ti5Al5V5Mo3Cr, Ti7Al4Mo, Ti3Al8V6Cr4Zr4Mo, Ti6Al6V6Sn, Ti15V3 Cr3Sn3Al	≤ 440 Bhn or ≤ 47 HRc	Profile 	≤ 0.05	≤ 1	140	RPM	2852	2139	1426	1070	856	713	535
					(112-168)	Fz	0.0005	0.0008	0.0015	0.0021	0.0026	0.0027	0.0029
					168	RPM	3423	2567	1711	1284	1027	856	642
		Finish 	≤ 0.02	≤ 2	(134-202)	Fz	0.0004	0.0006	0.0012	0.0017	0.0021	0.0022	0.0023
					168	RPM	3423	2567	1711	1284	1027	856	642
					168	RPM	3423	2567	1711	1284	1027	856	642
H TOOL STEELS A2, D2, H13, L2, M2, P20, S7, T15, W2	≤ 375 Bhn or ≤ 40 HRc	Profile 	≤ 0.05	≤ 1	290	RPM	5908	4431	2954	2216	1772	1477	1108
					(232-348)	Fz	0.0004	0.0006	0.0012	0.0016	0.0020	0.0021	0.0022
					348	RPM	7090	5317	3545	2659	2127	1772	1329
		Finish 	≤ 0.02	≤ 2	(278-418)	Fz	0.0003	0.0005	0.0010	0.0013	0.0016	0.0017	0.0018
					348	RPM	7090	5317	3545	2659	2127	1772	1329
					348	RPM	7090	5317	3545	2659	2127	1772	1329

Bhn (Brinell) HRc (Rockwell C)
 $rpm = Vc \times 3.82 / DC$
 $ipm = Fz \times \text{number of flutes} \times rpm$
 reduce speed and feed for materials harder than listed
 feed rates listed have chip thinning adjustments included where applicable
 refer to the SGS Tool Wizard® for complete technical information (www.kyocera-sgstool.com)



**66M •
66MCR**
METRIC SERIES

TOLERANCES (mm)

DC = +0,000/-0,050
DCON = h_6
RE = +0,000/-0,050

- STEELS
- STAINLESS STEELS
- CAST IRON
- HIGH TEMP ALLOYS
- TITANIUM
- HARDENED STEELS

For patent information visit www.ksptpatents.com

mm							EDP NO.
CUTTING DIAMETER DC	LENGTH OF CUT APMX	OVERALL LENGTH LF	SHANK DIAMETER DCON	CORNER RADIUS RE	NON-CUTTING CENTER DIAMETER NCD	NO. OF FLUTES	TI-NAMITE-X
6,0	19,0	63,0	6,0	—	1,63	7	46620
8,0	20,0	63,0	8,0	0,5	1,63	7	46627
6,0	19,0	63,0	6,0	1,0	1,63	7	46628
8,0	20,0	63,0	8,0	—	1,78	7	46621
8,0	20,0	63,0	8,0	0,5	1,78	7	46629
8,0	20,0	63,0	8,0	1,0	1,78	7	46630
8,0	20,0	63,0	8,0	1,5	1,78	7	46631
10,0	22,0	75,0	10,0	—	2,03	7	46622
10,0	22,0	75,0	10,0	0,5	2,03	7	46632
10,0	22,0	75,0	10,0	1,0	2,03	7	46633
10,0	22,0	75,0	10,0	1,5	2,03	7	46634
10,0	22,0	75,0	10,0	2,0	2,03	7	46635
12,0	26,0	83,0	12,0	—	3,45	9	46623
12,0	26,0	83,0	12,0	1,0	3,45	9	46636
12,0	26,0	83,0	12,0	1,5	3,45	9	46637
12,0	26,0	83,0	12,0	2,0	3,45	9	46638
12,0	26,0	83,0	12,0	2,5	3,45	9	46639
12,0	26,0	83,0	12,0	3,0	3,45	9	46640
16,0	32,0	92,0	16,0	—	2,92	9	46624
16,0	32,0	92,0	16,0	1,0	2,92	9	46641
16,0	32,0	92,0	16,0	1,5	2,92	9	46642
16,0	32,0	92,0	16,0	2,0	2,92	9	46643
16,0	32,0	92,0	16,0	2,5	2,92	9	46644
16,0	32,0	92,0	16,0	3,0	2,92	9	46645
16,0	32,0	92,0	16,0	4,0	2,92	9	46646
20,0	38,0	104,0	20,0	—	4,57	11	46625
20,0	38,0	104,0	20,0	1,0	4,57	11	46647
20,0	38,0	104,0	20,0	1,5	4,57	11	46648
20,0	38,0	104,0	20,0	2,0	4,57	11	46649
20,0	38,0	104,0	20,0	2,5	4,57	11	46650
20,0	38,0	104,0	20,0	3,0	4,57	11	46651
20,0	38,0	104,0	20,0	4,0	4,57	11	46652

- Heavy core and rigid design allow for straight walls
- High flute count design results in smoother cutting performance and enhanced tool life in precise finishing applications
- Enhanced corner geometry with tight tolerance corner radii
- Recommended for materials \leq 45 HRC (\leq 420 Bhn)

continued on next page

Neck Option Available

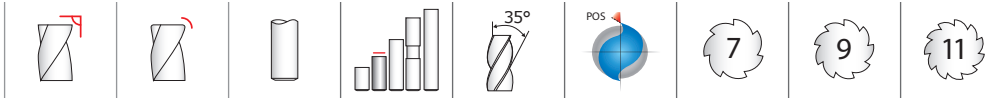

66M • 66MCR
METRIC SERIES

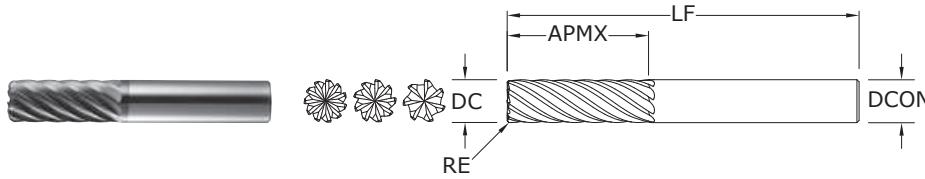

CONTINUED

mm							EDP NO.
CUTTING DIAMETER DC	LENGTH OF CUT APMX	OVERALL LENGTH LF	SHANK DIAMETER DCON	CORNER RADIUS RE	NON-CUTTING CENTER DIAMETER NCD	NO. OF FLUTES	TI-NAMITE-X
20,0	38,0	104,0	20,0	5,0	4,57	11	46653
25,0	38,0	104,0	25,0	—	7,49	11	46626
25,0	38,0	104,0	25,0	1,0	7,49	11	46654
25,0	38,0	104,0	25,0	1,5	7,49	11	46655
25,0	38,0	104,0	25,0	2,0	7,49	11	46656
25,0	38,0	104,0	25,0	2,5	7,49	11	46657
25,0	38,0	104,0	25,0	3,0	7,49	11	46658
25,0	38,0	104,0	25,0	4,0	7,49	11	46659
25,0	38,0	104,0	25,0	5,0	7,49	11	46660

Neck Option Available

TOLERANCES (mm)

DC = +0,000/-0,050
DCON = h_g
RE = +0,000/-0,050

- STEELS
- STAINLESS STEELS
- CAST IRON
- HIGH TEMP ALLOYS
- TITANIUM
- HARDENED STEELS

For patent information visit www.ksptpatents.com

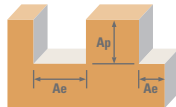

Series 66M, 66MCR Metric	Hardness	Ae x DC	Ap x DC	Vc (m/min)	DC • mm								
					6	8	10	12	16	20	25		
P	CARBON STEELS 1018, 1040, 1080, 1090, 10L50, 1140, 1212, 12L15, 1525, 1536	Profile 	≤ 0.05	≤ 1	194	RPM	10260	7695	6156	5130	3847	3078	2462
					(155-232)	Fz	0.029	0.047	0.059	0.072	0.095	0.101	0.105
					Feed (mm/min)	2068	2528	2528	3324	3280	3431	2844	
		Finish 	≤ 0.02	≤ 2	232	RPM	12312	9234	7387	6156	4617	3693	2955
					(186-279)	Fz	0.023	0.038	0.047	0.058	0.076	0.081	0.084
					Feed (mm/min)	1985	2427	2427	3191	3149	3294	2730	
	ALLOY STEELS 4140, 4150, 4320, 5120, 5150, 8630, 86L20, 50100	Profile 	≤ 0.05	≤ 1	110	RPM	5816	4362	3490	2908	2181	1745	1396
					(88-132)	Fz	0.022	0.036	0.045	0.055	0.074	0.080	0.080
					Feed (mm/min)	879	1108	1107	1445	1457	1536	1229	
		Finish 	≤ 0.02	≤ 2	132	RPM	6980	5235	4188	3490	2617	2094	1675
					(105-158)	Fz	0.017	0.029	0.036	0.044	0.059	0.064	0.064
					Feed (mm/min)	844	1063	1063	1387	1399	1474	1179	
M	STAINLESS STEELS (FREE MACHINING) 303, 416, 420F, 430F, 440F	Profile 	≤ 0.05	≤ 1	171	RPM	9048	6786	5429	4524	3393	2714	2171
					(137-205)	Fz	0.022	0.036	0.045	0.055	0.074	0.080	0.080
					Feed (mm/min)	1368	1723	1723	2247	2267	2389	1911	
		Finish 	≤ 0.02	≤ 2	137	RPM	7238	5429	4343	3619	2714	2171	1737
					(109-164)	Fz	0.017	0.029	0.036	0.044	0.059	0.064	0.064
					Feed (mm/min)	875	1103	1103	1438	1451	1529	1223	
	STAINLESS STEELS (DIFFICULT) 304, 304L, 316, 316L	Profile 	≤ 0.05	≤ 1	117	RPM	6220	4665	3732	3110	2333	1866	1493
					(94-141)	Fz	0.017	0.030	0.037	0.043	0.059	0.064	0.065
					Feed (mm/min)	731	975	975	1209	1236	1314	1067	
		Finish 	≤ 0.02	≤ 2	141	RPM	7465	5598	4479	3732	2799	2239	1791
					(113-169)	Fz	0.013	0.024	0.030	0.035	0.047	0.051	0.052
					Feed (mm/min)	702	17	936	1161	1187	1261	1025	
STAINLESS STEELS (PH) 13-8 PH, 15-5 PH, 17-4 PH, Custom 450	Profile 	≤ 0.05	≤ 1	108	RPM	5736	4302	3441	2868	2151	1721	1377	
				(87-130)	Fz	0.017	0.030	0.037	0.043	0.059	0.064	0.065	
				Feed (mm/min)	674	899	899	1115	1140	1211	984		
	Finish 	≤ 0.02	≤ 2	130	RPM	6883	5162	4130	3441	2581	2065	1652	
				(104-156)	Fz	0.013	0.024	0.030	0.035	0.047	0.051	0.052	
				Feed (mm/min)	647	863	863	1070	1094	1163	945		
K	CAST IRONS (LOW & MEDIUM ALLOY) Gray, Malleable, Ductile	Profile 	≤ 0.05	≤ 1	215	RPM	11391	8543	6834	5695	4271	3417	2734
					(172-258)	Fz	0.029	0.047	0.059	0.072	0.095	0.101	0.105
					Feed (mm/min)	2296	2807	2807	3690	3641	3809	3158	
		Finish 	≤ 0.02	≤ 2	258	RPM	13669	10252	8201	6834	5126	4101	3281
					(206-309)	Fz	0.023	0.038	0.047	0.058	0.076	0.081	0.084
					Feed (mm/min)	2204	2695	2694	3543	3496	3657	3031	

continued on next page

Multi-Carb

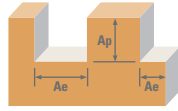

Series 66M, 66MCR	Metric	Hardness	Ae x DC	Ap x DC	Vc (m/min)	DC • mm								
						6	8	10	12	16	20	25		
K	CAST IRONS (HIGH ALLOY) Gray, Malleable, Ductile	≤ 260 Bhn or ≤ 26 HRc	Profile	≤ 0.05	≤ 1	165	RPM	8725	6544	5235	4362	3272	2617	2094
						(132-198)	Fz	0.022	0.036	0.045	0.055	0.074	0.080	0.080
						198	RPM	10470	7852	6282	5235	3926	3141	2513
						(158-237)	Fz	0.017	0.029	0.036	0.044	0.059	0.064	0.064
						Feed (mm/min)	1319	1661	1661	2167	2186	2303	1843	
						Feed (mm/min)	1266	1595	1595	2080	2099	2211	1769	
S	SUPER ALLOYS (NICKEL, COBALT, IRON BASE) Inconel 601, 617, 625, Incoloy, Monel 400	≤ 300 Bhn or ≤ 32 HRc	Profile	≤ 0.05	≤ 1	32	RPM	1696	1272	1018	848	636	509	407
						(26-38)	Fz	0.017	0.030	0.037	0.043	0.059	0.064	0.065
						38	RPM	2036	1527	1221	1018	763	611	489
						(31-46)	Fz	0.013	0.024	0.030	0.035	0.047	0.051	0.052
						Feed (mm/min)	199	266	213	330	337	358	291	
						Feed (mm/min)	192	255	255	317	324	344	279	
	SUPER ALLOYS (NICKEL, COBALT, IRON BASE) Inconel 718, X-750, Incoloy, Waspaloy, Hastelloy, Rene	≤ 400 Bhn or ≤ 43 HRc	Profile	≤ 0.05	≤ 1	26	RPM	1373	1030	824	687	515	412	330
						(21-31)	Fz	0.012	0.019	0.024	0.026	0.036	0.040	0.040
						31	RPM	1648	1236	989	824	618	494	396
						(25-37)	Fz	0.010	0.015	0.019	0.021	0.029	0.032	0.032
						Feed (mm/min)	115	138	138	163	166	181	145	
						Feed (mm/min)	111	133	133	157	159	174	139	
TITANIUM ALLOYS Pure Titanium, Ti6Al4V, Ti6Al2Sn4Zr2Mo, Ti4Al4Mo2Sn0.5Si	≤ 350 Bhn or ≤ 38 HRc	Profile	≤ 0.05	≤ 1	119	RPM	6301	4726	3781	3151	2363	1890	1512	
					(95-143)	Fz	0.019	0.032	0.040	0.050	0.067	0.072	0.073	
					143	RPM	7561	5671	4537	3781	2836	2268	1815	
					(114-171)	Fz	0.015	0.026	0.032	0.040	0.053	0.058	0.058	
					Feed (mm/min)	847	1059	1059	1429	1415	1497	1206		
					Feed (mm/min)	813	1016	1016	1372	1359	1437	1158		
TITANIUM ALLOYS (DIFFICULT) Ti10Al2Fe3Al, Ti5Al5V5Mo3Cr, Ti7Al4Mo, Ti3Al8V6Cr4Zr4Mo, Ti6Al6V6Sn, Ti15V3 Cr3Sn3Al	≤ 440 Bhn or ≤ 47 HRc	Profile	≤ 0.05	≤ 1	43	RPM	2262	1696	1357	1131	848	679	543	
					(34-51)	Fz	0.019	0.032	0.040	0.050	0.067	0.072	0.073	
					51	RPM	2714	2036	1629	1357	1018	814	651	
					(41-61)	Fz	0.015	0.026	0.032	0.040	0.053	0.058	0.058	
					Feed (mm/min)	304	380	380	513	508	537	433		
					Feed (mm/min)	292	365	365	492	488	516	416		
H	TOOL STEELS A2, D2, H13, L2, M2, P20, S7, T15, W2	≤ 375 Bhn or ≤ 40 HRc	Profile	≤ 0.05	≤ 1	88	RPM	4686	3514	2811	2343	1757	1406	1125
						(71-106)	Fz	0.014	0.026	0.032	0.038	0.051	0.056	0.055
						106	RPM	5623	4217	3374	2811	2108	1687	1349
						(85-127)	Fz	0.012	0.020	0.026	0.031	0.041	0.045	0.044
						Feed (mm/min)	472	630	630	810	810	866	680	
						Feed (mm/min)	453	605	605	777	777	831	653	

Bhn (Brinell) HRc (Rockwell C)
 rpm = (Vc x 1000) / (DC x 3.14)
 mm/min = Fz x number of flutes x rpm
 reduce speed and feed for materials harder than listed
 feed rates listed have chip thinning adjustments included where applicable
 refer to the SGS Tool Wizard® for complete technical information (www.kyocera-sgstool.com)

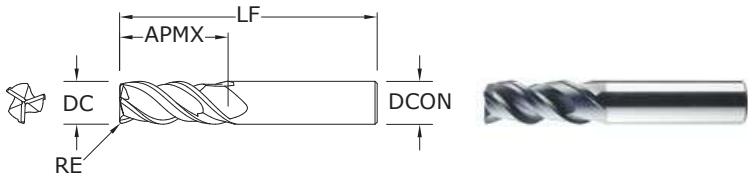

33CR
FRACTIONAL SERIES

TOLERANCES (inch)

1/8–1/4 DIAMETER
DC = +0.0000/–0.0012
DCON = h_6
RE = +0.0000/–0.0020

>1/4–3/8 DIAMETER
DC = +0.0000/–0.0016
DCON = h_6
RE = +0.0000/–0.0020

>3/8–1 DIAMETER
DC = +0.0000/–0.0020
DCON = h_6
RE = +0.0000/–0.0020

- STEELS
- STAINLESS STEELS
- CAST IRON
- HIGH TEMP ALLOYS
- TITANIUM
- HARDENED STEELS

For patent information visit www.ksptpatents.com

CUTTING DIAMETER DC	LENGTH OF CUT APMX	inch			CORNER RADIUS RE	EDP NO. TI-NAMITE-A (AITiN)
		OVERALL LENGTH LF	SHANK DIAMETER DCON			
1/8	3/8	2-1/2	1/4	.015	33345	
3/16	9/16	2-1/2	1/4	.015	33346	
1/4	3/4	2-1/2	1/4	.020	33347	
5/16	13/16	2-1/2	5/16	.020	33348	
3/8	1	2-1/2	3/8	.020	33349	
7/16	1-1/8	2-3/4	7/16	.020	33350	
1/2	1-1/4	3-1/4	1/2	.030	33351	
5/8	1-1/2	3-1/2	5/8	.040	33352	
3/4	1-3/4	4	3/4	.040	33353	
1	2-1/4	5	1	.040	33354	

- Specially engineered step core design provides stability for aggressive ramping and rigidity when flutes are completely engaged
- Open design at axial end accommodates material flow and load reduction during machining operations
- Enhanced corner geometry with tight tolerance corner radii
- Recommended for materials ≤ 45 HRc (≤ 420 Bhn)

FRACTIONAL
Series 33

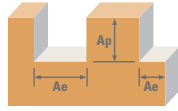

Series 33CR Fractional	Hardness	Ae x DC	Ap x DC	Vc (sfm)	DC • in									
					1/8	1/4	3/8	1/2	5/8	3/4	1			
P CARBON STEELS 1018, 1040, 1080, 1090, 10L50, 1140, 1212, 12L15, 1525, 1536	≤ 275 Bhn or ≤ 28 HRc	Profile 	≤ 0.5	≤ 1.5	550	RPM	16808	8404	5603	4202	3362	2801	2101	
					(440-660)	Fz	0.0005	0.0012	0.0023	0.0031	0.0039	0.0040	0.0043	
						Feed (ipm)	25.2	30.3	38.7	39.1	39.3	33.6	27.1	
		Slot 	1	≤ 1	440	RPM	13446	6723	4482	3362	2689	2241	1681	
					(352-528)	Fz	0.0005	0.0012	0.0023	0.0031	0.0039	0.0040	0.0043	
						Feed (ipm)	20.2	24.2	30.9	31.3	31.5	26.9	21.7	
	ALLOY STEELS 4140, 4150, 4320, 5120, 5150, 8630, 86L20, 50100	≤ 375 Bhn or ≤ 40 HRc	Profile 	≤ 0.5	≤ 1.5	315	RPM	9626	4813	3209	2407	1925	1604	1203
						(252-378)	Fz	0.0004	0.0009	0.0017	0.0023	0.0029	0.0030	0.0032
							Feed (ipm)	11.6	13.0	16.4	16.6	16.7	14.4	11.6
			Slot 	1	≤ 1	250	RPM	7640	3820	2547	1910	1528	1273	955
						(200-300)	Fz	0.0004	0.0009	0.0017	0.0023	0.0029	0.0030	0.0032
							Feed (ipm)	9.2	10.3	13.0	13.2	13.3	11.5	9.2
M STAINLESS STEELS (FREE MACHINING) 303, 416, 420F, 430F, 440F	≤ 275 Bhn or ≤ 28 HRc	Profile 	≤ 0.5	≤ 1.5	490	RPM	14974	7487	4991	3744	2995	2496	1872	
					(392-588)	Fz	0.0004	0.0010	0.0019	0.0025	0.0031	0.0032	0.0035	
						Feed (ipm)	17.1	22.5	28.5	28.1	27.9	24.0	19.7	
		Slot 	1	≤ 1	390	RPM	11918	5959	3973	2980	2384	1986	1490	
					(312-468)	Fz	0.0004	0.0010	0.0019	0.0025	0.0031	0.0032	0.0035	
						Feed (ipm)	13.6	17.9	22.6	22.3	22.2	19.1	15.6	
	STAINLESS STEELS (DIFFICULT) 304, 304L, 316, 316L	≤ 275 Bhn or ≤ 28 HRc	Profile 	≤ 0.5	≤ 1.5	340	RPM	10390	5195	3463	2598	2078	1732	1299
						(272-408)	Fz	0.0003	0.0008	0.0015	0.0020	0.0025	0.0026	0.0028
							Feed (ipm)	9.4	12.5	15.6	15.6	15.6	13.5	10.9
			Slot 	1	≤ 1	270	RPM	8251	4126	2750	2063	1650	1375	1031
						(216-324)	Fz	0.0003	0.0008	0.0015	0.0020	0.0025	0.0026	0.0028
							Feed (ipm)	7.4	9.9	12.4	12.4	12.4	10.7	8.7
STAINLESS STEELS (PH) 13-8 PH, 15-5 PH, 17-4 PH, Custom 450	≤ 325 Bhn or ≤ 35 HRc	Profile 	≤ 0.5	≤ 1.5	310	RPM	9474	4737	3158	2368	1895	1579	1184	
					(248-372)	Fz	0.0003	0.0008	0.0015	0.0020	0.0025	0.0026	0.0028	
						Feed (ipm)	8.5	11.4	14.2	14.2	14.2	12.3	9.9	
		Slot 	1	≤ 1	250	RPM	7640	3820	2547	1910	1528	1273	955	
					(200-300)	Fz	0.0003	0.0008	0.0015	0.0020	0.0025	0.0026	0.0028	
						Feed (ipm)	6.9	9.2	11.5	11.5	11.5	9.9	8.0	
K CAST IRONS (LOW & MEDIUM ALLOY) Gray, Malleable, Ductile	≤ 220 Bhn or ≤ 19 HRc	Profile 	≤ 0.5	≤ 1.5	445	RPM	13599	6800	4533	3400	2720	2267	1700	
					(356-534)	Fz	0.0004	0.0011	0.0021	0.0028	0.0035	0.0036	0.0039	
						Feed (ipm)	14.3	22.4	28.6	28.6	28.6	24.5	19.9	
		Slot 	1	≤ 1	355	RPM	10849	5424	3616	2712	2170	1808	1356	
					(284-426)	Fz	0.0004	0.0011	0.0021	0.0028	0.0035	0.0036	0.0039	
						Feed (ipm)	11.4	17.9	22.8	22.8	22.8	19.5	15.9	

continued on next page

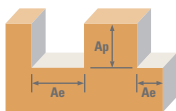

Series 33CR Fractional	Hardness	Ae x DC	Ap x DC	Vc (sfm)	DC • in									
					1/8	1/4	3/8	1/2	5/8	3/4	1			
K CAST IRONS (HIGH ALLOY) Gray, Malleable, Ductile	≤ 260 Bhn or ≤ 26 HRC	Profile 	≤ 0.5	≤ 1.5	340	RPM	10390	5195	3463	2598	2078	1732	1299	
					(272-408)	Fz	0.0003	0.0008	0.0016	0.0021	0.0026	0.0027	0.0029	
					Feed (ipm)	9.4	12.5	16.6	16.4	16.2	14.0	11.3		
		Slot 	1	≤ 1	270	RPM	8251	4126	2750	2063	1650	1375	1031	
					(216-324)	Fz	0.0003	0.0008	0.0016	0.0021	0.0026	0.0027	0.0029	
					Feed (ipm)	7.4	9.9	13.2	13.0	12.9	11.1	9.0		
	S SUPER ALLOYS (NICKEL, COBALT, IRON BASE) Inconel 601, 617, 625, Incoloy, Monel 400	≤ 300 Bhn or ≤ 32 HRC	Profile 	≤ 0.5	≤ 1.5	80	RPM	2445	1222	815	611	489	407	306
						(64-96)	Fz	0.0003	0.0007	0.0013	0.0017	0.0021	0.0022	0.0024
						Feed (ipm)	1.9	2.6	3.2	3.1	3.1	2.7	2.2	
			Slot 	1	≤ 1	65	RPM	1986	993	662	497	397	331	248
						(52-78)	Fz	0.0003	0.0007	0.0013	0.0017	0.0021	0.0022	0.0024
						Feed (ipm)	1.5	2.1	2.6	2.5	2.5	2.2	1.8	
≤ 400 Bhn or ≤ 43 HRC		Profile 	≤ 0.5	≤ 1.5	62	RPM	1895	947	632	474	379	316	237	
					(50-74)	Fz	0.0002	0.0005	0.0009	0.0012	0.0015	0.0016	0.0017	
					Feed (ipm)	1.1	1.4	1.7	1.7	1.7	1.5	1.2		
		Slot 	1	≤ 1	49	RPM	1497	749	499	374	299	250	187	
					(39-59)	Fz	0.0002	0.0005	0.0009	0.0012	0.0015	0.0016	0.0017	
					Feed (ipm)	0.9	1.1	1.3	1.3	1.3	1.2	1.0		
S TITANIUM ALLOYS Pure Titanium, Ti6Al4V, Ti6Al2Sn4Zr2Mo, Ti4Al4Mo2Sn0.5Si	≤ 350 Bhn or ≤ 38 HRC	Profile 	≤ 0.5	≤ 1.5	215	RPM	6570	3285	2190	1643	1314	1095	821	
					(172-258)	Fz	0.0003	0.0008	0.0015	0.0020	0.0025	0.0026	0.0028	
					Feed (ipm)	5.9	7.9	9.9	9.9	9.9	8.5	6.9		
		Slot 	1	≤ 1	170	RPM	5195	2598	1732	1299	1039	866	649	
					(136-204)	Fz	0.0003	0.0008	0.0015	0.0020	0.0025	0.0026	0.0028	
					Feed (ipm)	4.7	6.2	7.8	7.8	7.8	6.8	5.5		
	≤ 440 Bhn or ≤ 47 HRC	Profile 	≤ 0.5	≤ 1.5	75	RPM	2292	1146	764	573	458	382	287	
					(60-90)	Fz	0.0003	0.0008	0.0015	0.0020	0.0025	0.0026	0.0028	
					Feed (ipm)	2.1	2.8	3.4	3.4	3.4	3.0	2.4		
		Slot 	1	≤ 1	60	RPM	1834	917	611	458	367	306	229	
					(48-72)	Fz	0.0003	0.0008	0.0015	0.0020	0.0025	0.0026	0.0028	
					Feed (ipm)	1.7	2.2	2.8	2.8	2.8	2.4	1.9		
H TOOL STEELS A2, D2, H13, L2, M2, P20, S7, T15, W2	≤ 375 Bhn or ≤ 40 HRC	Profile 	≤ 0.5	≤ 1.5	185	RPM	5654	2827	1885	1413	1131	942	707	
					(148-222)	Fz	0.0003	0.0007	0.0014	0.0018	0.0023	0.0024	0.0025	
					Feed (ipm)	5.1	5.9	7.9	7.6	7.8	6.8	5.3		
		Slot 	1	≤ 1	145	RPM	4431	2216	1477	1108	886	739	554	
					(116-174)	Fz	0.0003	0.0007	0.0014	0.0018	0.0023	0.0024	0.0025	
					Feed (ipm)	4.0	4.7	6.2	6.0	6.1	5.3	4.2		

Bhn (Brinell) HRC (Rockwell C)

rpm = Vc x 3.82 / DC

ipm = Fz x 3 x rpm

reduce speed and feed for materials harder than listed

reduce feed and Ae when finish milling (.02 x DC maximum)

feed rates listed have chip thinning adjustments included where applicable

refer to the SGS Tool Wizard® for complete technical information (www.kyocera-sgstoool.com)



33MCR METRIC SERIES

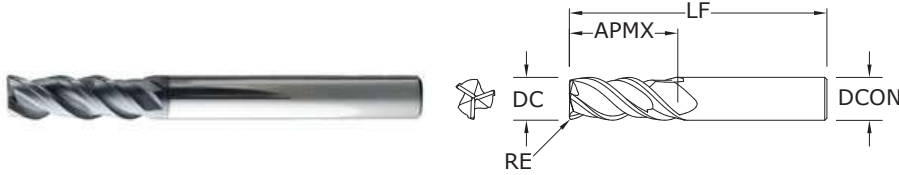

- Specially engineered step core design provides stability for aggressive ramping and rigidity when flutes are completely engaged
- Open design at axial end accommodates material flow and load reduction during machining operations
- Enhanced corner geometry with tight tolerance corner radii
- Recommended for materials ≤ 45 HRc (≤ 420 Bhn)

CUTTING DIAMETER DC	LENGTH OF CUT APMX	mm			CORNER RADIUS RE	EDP NO. TI-NAMITE-A (AlTiN)
		OVERALL LENGTH LF	SHANK DIAMETER DCON			
3,0	9,0	57,0	6,0	0,3	43445	
3,0	9,0	57,0	6,0	0,5	43470	
4,0	12,0	57,0	6,0	0,3	43446	
4,0	12,0	57,0	6,0	0,5	43471	
5,0	15,0	57,0	6,0	0,3	43447	
5,0	15,0	57,0	6,0	0,5	43472	
6,0	18,0	57,0	6,0	0,5	43448	
6,0	18,0	57,0	6,0	1,0	43473	
6,0	18,0	57,0	6,0	1,5	43474	
6,0	18,0	57,0	6,0	2,0	43475	
8,0	20,0	63,0	8,0	0,5	43449	
8,0	20,0	63,0	8,0	1,0	43476	
8,0	20,0	63,0	8,0	1,5	43477	
8,0	20,0	63,0	8,0	2,0	43478	
10,0	27,0	72,0	10,0	0,5	43450	
10,0	27,0	72,0	10,0	1,0	43479	
10,0	27,0	72,0	10,0	1,5	43480	
10,0	27,0	72,0	10,0	2,0	43481	
10,0	27,0	72,0	10,0	2,5	43482	
12,0	30,0	83,0	12,0	0,5	43451	
12,0	30,0	83,0	12,0	1,0	43483	
12,0	30,0	83,0	12,0	1,5	43484	
12,0	30,0	83,0	12,0	2,0	43485	
12,0	30,0	83,0	12,0	2,5	43486	
12,0	30,0	83,0	12,0	3,0	43487	
12,0	30,0	83,0	12,0	4,0	43488	
16,0	38,0	92,0	16,0	1,0	43452	
16,0	38,0	92,0	16,0	1,5	43489	
16,0	38,0	92,0	16,0	2,0	43490	
16,0	38,0	92,0	16,0	2,5	43491	
16,0	38,0	92,0	16,0	3,0	43492	
16,0	38,0	92,0	16,0	4,0	43493	
20,0	46,0	104,0	20,0	1,0	43453	
20,0	46,0	104,0	20,0	2,0	43494	
20,0	46,0	104,0	20,0	2,5	43495	
20,0	46,0	104,0	20,0	3,0	43496	
20,0	46,0	104,0	20,0	4,0	43497	

TOLERANCES (mm)

3-6 DIAMETER

DC = +0,000/-0,030
 DCON = h_6
 RE = +0,000/-0,050

>6-10 DIAMETER

DC = +0,000/-0,040
 DCON = h_6
 RE = +0,000/-0,050

>10-20 DIAMETER

DC = +0,000/-0,050
 DCON = h_6
 RE = +0,000/-0,050

- STEELS
- STAINLESS STEELS
- CAST IRON
- HIGH TEMP ALLOYS
- TITANIUM
- HARDENED STEELS

For patent information visit www.kspatents.com

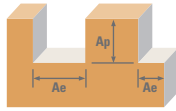

Series 33MCR Metric	Hardness	Ae x DC	Ap x DC	Vc (m/min)	DC • mm									
					3	6	8	10	12	16	20			
P CARBON STEELS 1018, 1040, 1080, 1090, 10L50, 1140, 1212, 12L15, 1525, 1536	≤ 275 Bhn or ≤ 28 HRc	Profile 	≤ 0.5	≤ 1.5	168	RPM	17773	8886	6665	5332	4443	3332	2666	
					(134-201)	Fz	0.012	0.029	0.049	0.061	0.074	0.100	0.107	
					Feed (mm/min)	640	768	981	981	992	998	853		
		Slot 	1	≤ 1	134	RPM	14218	7109	5332	4265	3555	2666	2133	
					(107-161)	Fz	0.012	0.029	0.049	0.061	0.074	0.100	0.107	
					Feed (mm/min)	512	614	785	785	793	798	682		
	ALLOY STEELS 4140, 4150, 4320, 5120, 5150, 8630, 86L20, 50100	≤ 375 Bhn or ≤ 40 HRc	Profile 	≤ 0.5	≤ 1.5	96	RPM	10179	5089	3817	3054	2545	1909	1527
						(77-115)	Fz	0.010	0.022	0.036	0.045	0.055	0.074	0.080
						Feed (mm/min)	293	330	415	415	421	425	366	
			Slot 	1	≤ 1	76	RPM	8078	4039	3029	2424	2020	1515	1212
						(61-91)	Fz	0.010	0.022	0.036	0.045	0.055	0.074	0.080
						Feed (mm/min)	233	262	330	330	334	337	291	
M STAINLESS STEELS (FREE MACHINING) 303, 416, 420F, 430F, 440F	≤ 275 Bhn or ≤ 28 HRc	Profile 	≤ 0.5	≤ 1.5	149	RPM	15834	7917	5938	4750	3958	2969	2375	
					(119-179)	Fz	0.009	0.024	0.041	0.051	0.060	0.079	0.085	
					Feed (mm/min)	433	570	722	722	712	707	608		
		Slot 	1	≤ 1	119	RPM	12602	6301	4726	3781	3151	2363	1890	
					(95-143)	Fz	0.009	0.024	0.041	0.051	0.060	0.079	0.085	
					Feed (mm/min)	345	454	575	575	567	563	484		
	STAINLESS STEELS (DIFFICULT) 304, 304L, 316, 316L	≤ 275 Bhn or ≤ 28 HRc	Profile 	≤ 0.5	≤ 1.5	104	RPM	10987	5493	4120	3296	2747	2060	1648
						(83-124)	Fz	0.007	0.019	0.032	0.040	0.048	0.064	0.069
						Feed (mm/min)	237	316	396	396	395	396	343	
			Slot 	1	≤ 1	82	RPM	8725	4362	3272	2617	2181	1636	1309
						(66-99)	Fz	0.007	0.019	0.032	0.040	0.048	0.064	0.069
						Feed (mm/min)	188	251	314	314	314	314	272	
STAINLESS STEELS (PH) 13-8 PH, 15-5 PH, 17-4 PH, Custom 450	≤ 325 Bhn or ≤ 35 HRc	Profile 	≤ 0.5	≤ 1.5	94	RPM	10017	5009	3756	3005	2504	1878	1503	
					(76-113)	Fz	0.007	0.019	0.032	0.040	0.048	0.064	0.069	
					Feed (mm/min)	216	288	361	361	361	361	313		
		Slot 	1	≤ 1	76	RPM	8078	4039	3029	2424	2020	1515	1212	
					(61-91)	Fz	0.007	0.019	0.032	0.040	0.048	0.064	0.069	
					Feed (mm/min)	174	233	291	291	291	291	252		
K CAST IRONS (LOW & MEDIUM ALLOY) Gray, Malleable, Ductile	≤ 220 Bhn or ≤ 19 HRc	Profile 	≤ 0.5	≤ 1.5	136	RPM	14380	7190	5392	4314	3595	2696	2157	
					(109-163)	Fz	0.008	0.026	0.045	0.056	0.067	0.090	0.096	
					Feed (mm/min)	362	569	725	725	725	725	621		
		Slot 	1	≤ 1	108	RPM	11471	5736	4302	3441	2868	2151	1721	
					(87-130)	Fz	0.008	0.026	0.045	0.056	0.067	0.090	0.096	
					Feed (mm/min)	289	454	578	578	578	578	496		

continued on next page

Series 33

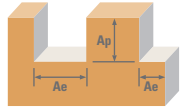

Series 33MCR Metric	Hardness	Ae x DC	Ap x DC	Vc (m/min)	DC • mm									
					3	6	8	10	12	16	20			
K CAST IRONS (HIGH ALLOY) Gray, Malleable, Ductile	≤ 260 Bhn or ≤ 26 HRC	Profile 	≤ 0.5	≤ 1.5	104	RPM	10987	5493	4120	3296	2747	2060	1648	
					(83-124)	Fz	0.007	0.019	0.034	0.043	0.050	0.067	0.072	
					Feed (mm/min)	237	316	422	422	415	411	356		
		Slot 	1	≤ 1	82	RPM	8725	4362	3272	2617	2181	1636	1309	
					(66-99)	Fz	0.007	0.019	0.034	0.043	0.050	0.067	0.072	
					Feed (mm/min)	188	251	335	335	330	327	283		
	S SUPER ALLOYS (NICKEL, COBALT, IRON BASE) Inconel 601, 617, 625, Incoloy, Monel 400	≤ 300 Bhn or ≤ 32 HRC	Profile 	≤ 0.5	≤ 1.5	24	RPM	2585	1293	969	776	646	485	388
						(20-29)	Fz	0.006	0.017	0.028	0.035	0.041	0.054	0.059
						Feed (mm/min)	48	65	81	65	79	78	68	
			Slot 	1	≤ 1	20	RPM	2100	1050	788	630	525	394	315
						(16-24)	Fz	0.006	0.017	0.028	0.035	0.041	0.054	0.059
						Feed (mm/min)	39	53	66	66	64	64	55	
≤ 400 Bhn or ≤ 43 HRC		Profile 	≤ 0.5	≤ 1.5	19	RPM	2003	1002	751	601	501	376	301	
					(15-23)	Fz	0.005	0.012	0.019	0.024	0.029	0.038	0.043	
					Feed (mm/min)	29	36	43	43	43	43	38		
		Slot 	1	≤ 1	15	RPM	1583	792	594	475	396	297	238	
					(12-18)	Fz	0.005	0.012	0.019	0.024	0.029	0.038	0.043	
					Feed (mm/min)	23	28	34	34	34	34	30		
TITANIUM ALLOYS Pure Titanium, Ti6Al4V, Ti6Al2Sn4Zr2Mo, Ti4Al4Mo2Sn0.5Si	≤ 350 Bhn or ≤ 38 HRC	Profile 	≤ 0.5	≤ 1.5	66	RPM	6947	3474	2605	2084	1737	1303	1042	
					(52-79)	Fz	0.007	0.019	0.032	0.040	0.048	0.064	0.069	
					Feed (mm/min)	150	200	250	250	250	250	217		
		Slot 	1	≤ 1	52	RPM	5493	2747	2060	1648	1373	1030	824	
					(41-62)	Fz	0.007	0.019	0.032	0.040	0.048	0.064	0.069	
					Feed (mm/min)	119	158	198	198	198	198	171		
	≤ 440 Bhn or ≤ 47 HRC	Profile 	≤ 0.5	≤ 1.5	23	RPM	2424	1212	909	727	606	454	364	
					(18-27)	Fz	0.007	0.019	0.032	0.040	0.048	0.064	0.069	
					Feed (mm/min)	52	70	87	87	87	87	76		
		Slot 	1	≤ 1	18	RPM	1939	969	727	582	485	364	291	
					(15-22)	Fz	0.007	0.019	0.032	0.040	0.048	0.064	0.069	
					Feed (mm/min)	42	56	70	70	70	70	60		
H TOOL STEELS A2, D2, H13, L2, M2, P20, S7, T15, W2	≤ 375 Bhn or ≤ 40 HRC	Profile 	≤ 0.5	≤ 1.5	56	RPM	5978	2989	2242	1793	1495	1121	897	
					(45-68)	Fz	0.007	0.017	0.030	0.037	0.043	0.059	0.064	
					Feed (mm/min)	129	151	201	201	194	198	172		
		Slot 	1	≤ 1	44	RPM	4686	2343	1757	1406	1171	879	703	
					(35-53)	Fz	0.007	0.017	0.030	0.037	0.043	0.059	0.064	
					Feed (mm/min)	101	118	157	157	152	155	135		

Bhn (Brinell) HRC (Rockwell C)
 rpm = (Vc x 1000) / (DC x 3.14)
 mm/min = Fz x 3 x rpm
 reduce speed and feed for materials harder than listed
 reduce feed and Ae when finish milling (.02 x DC maximum)
 feed rates listed have chip thinning adjustments included where applicable
 refer to the SGS Tool Wizard® for complete technical information (www.kyocera-sgstool.com)

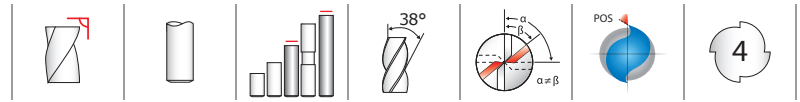

7
FRACTIONAL SERIES

TOLERANCES (inch)

DC = +0.0000/-0.0020
DCON = h₆

- STEELS
- STAINLESS STEELS
- CAST IRON
- HIGH TEMP ALLOYS
- TITANIUM
- HARDENED STEELS

For patent information visit www.kspatents.com

inch				EDP NO.
CUTTING DIAMETER DC	LENGTH OF CUT APMX	OVERALL LENGTH LF	SHANK DIAMETER DCON	Ti-NAMITE-X
1/8	3/4	2-1/4	1/8	70470
1/8	1	3	1/8	70471
3/16	3/4	2-1/2	3/16	70472
3/16	1-1/8	3	3/16	70473
1/4	1-1/8	3	1/4	70474
1/4	1-1/2	4	1/4	70475
5/16	1-1/8	3	5/16	70476
5/16	1-5/8	4	5/16	70477
3/8	1-1/8	3	3/8	70478
3/8	1-3/4	4	3/8	70479
7/16	2	4-1/2	7/16	70480
7/16	3	6	7/16	70481
1/2	2	4-1/2	1/2	70482
1/2	3	6	1/2	70483
5/8	2-1/4	5	5/8	70484
5/8	3	6	5/8	70485
3/4	2-1/4	5	3/4	70486
3/4	3	6	3/4	70487
1	2-1/4	5	1	70488
1	3	6	1	70489

- Variable pitch allows for improved chatter suppression along with improved surface finish and enhanced tool life
- Raised land and increased core diameter designed to enhance tool life and decrease tool deflection
- Recommended for materials ≤ 45 HRc (≤ 420 Bhn)



7M
METRIC SERIES

TOLERANCES (mm)

DC = +0,000/+0,050
DCON = h₆

- STEELS
- STAINLESS STEELS
- CAST IRON
- HIGH TEMP ALLOYS
- TITANIUM
- HARDENED STEELS

For patent information visit www.kspatents.com

mm				EDP NO.
CUTTING DIAMETER DC	LENGTH OF CUT APMX	OVERALL LENGTH LF	SHANK DIAMETER DCON	Ti-NAMITE-X
3,0	25,0	75,0	3,0	70551
4,0	25,0	75,0	4,0	70552
5,0	25,0	75,0	5,0	70553
6,0	25,0	75,0	6,0	70554
8,0	25,0	75,0	8,0	70555
10,0	38,0	100,0	10,0	70556
12,0	50,0	100,0	12,0	70557
12,0	75,0	150,0	12,0	70558
14,0	75,0	150,0	14,0	70559
16,0	75,0	150,0	16,0	70560
18,0	75,0	150,0	18,0	70561
20,0	75,0	150,0	20,0	70562
25,0	75,0	150,0	25,0	70563

- Variable pitch allows for improved chatter suppression along with improved surface finish and enhanced tool life
- Raised land and increased core diameter designed to enhance tool life and decrease tool deflection
- Recommended for materials ≤ 45 HRc (≤ 420 Bhn)

Series 7

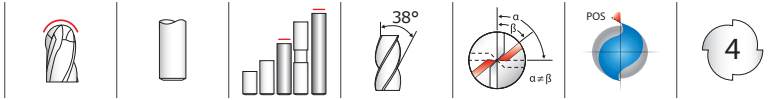

7B FRACTIONAL SERIES

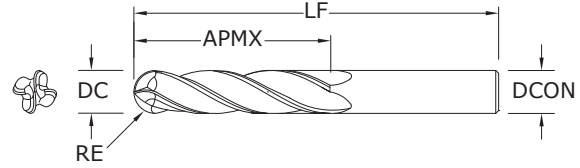

- Variable pitch allows for improved chatter suppression along with improved surface finish and enhanced tool life
- Raised land and increased core diameter designed to enhance tool life and decrease tool deflection
- Ball nose design ideal for finishing operations in complex workpieces
- Recommended for materials ≤ 45 HRc (≤ 420 Bhn)

inch				EDP NO.
CUTTING DIAMETER DC	LENGTH OF CUT APMX	OVERALL LENGTH LF	SHANK DIAMETER DCON	Ti-NAMITE-X
1/8	3/4	2-1/4	1/8	70441
1/8	1	3	1/8	70442
3/16	3/4	2-1/2	3/16	70444
3/16	1-1/8	3	3/16	70445
1/4	1-1/8	3	1/4	70447
1/4	1-1/2	4	1/4	70448
5/16	1-1/8	3	5/16	70450
5/16	1-5/8	4	5/16	70451
3/8	1-1/8	3	3/8	70453
3/8	1-3/4	4	3/8	70454
7/16	2	4-1/2	7/16	70456
7/16	3	6	7/16	70457
1/2	2	4-1/2	1/2	70459
1/2	3	6	1/2	70460
5/8	2-1/4	5	5/8	70462
5/8	3	6	5/8	70463
3/4	2-1/4	5	3/4	70465
3/4	3	6	3/4	70466
1	2-1/4	5	1	70468
1	3	6	1	70469

RE = 1/2 Cutting Diameter (DC)

TOLERANCES (inch)
 DC = +0.0000/-0.0020
 DCON = h_6
 RE = +0.0000/-0.0010

- STEELS
- STAINLESS STEELS
- CAST IRON
- HIGH TEMP ALLOYS
- TITANIUM
- HARDENED STEELS

For patent information visit www.ksptpatents.com

7MB METRIC SERIES

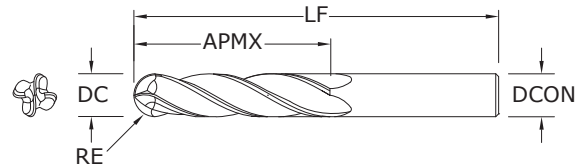

- Variable pitch allows for improved chatter suppression along with improved surface finish and enhanced tool life
- Raised land and increased core diameter designed to enhance tool life and decrease tool deflection
- Ball nose design ideal for finishing operations in complex workpieces
- Recommended for materials ≤ 45 HRc (≤ 420 Bhn)

mm				EDP NO.
CUTTING DIAMETER DC	LENGTH OF CUT APMX	OVERALL LENGTH LF	SHANK DIAMETER DCON	Ti-NAMITE-X
3,0	25,0	75,0	3,0	70527
4,0	25,0	75,0	4,0	70529
5,0	25,0	75,0	5,0	70531
6,0	25,0	75,0	6,0	70533
8,0	25,0	75,0	8,0	70535
10,0	38,0	100,0	10,0	70537
12,0	50,0	100,0	12,0	70539
12,0	75,0	150,0	12,0	70540
14,0	75,0	150,0	14,0	70542
16,0	75,0	150,0	16,0	70544
18,0	75,0	150,0	18,0	70546
20,0	75,0	150,0	20,0	70548
25,0	75,0	150,0	25,0	70550

RE = 1/2 Cutting Diameter (DC)

TOLERANCES (mm)
 DC = +0,000/+0,050
 DCON = h_6
 RE = +0,000/-0,025

- STEELS
- STAINLESS STEELS
- CAST IRON
- HIGH TEMP ALLOYS
- TITANIUM
- HARDENED STEELS

For patent information visit www.ksptpatents.com

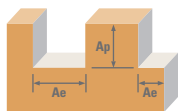

Series	7, 7B	Hardness	Finish	Ae x DC	Ap x DC	Vc (sfm)	DC • in							
							1/8	1/4	3/8	1/2	5/8	3/4	1	
P	CARBON STEELS 1018, 1040, 1080, 1090, 10L50, 1140, 1212, 12L15, 1525, 1536	≤ 275 Bhn or ≤ 28 HRc		≤ 0.02	≤ 2	480	RPM	14669	7334	4890	3667	2934	2445	1834
		(384-576)				Fz	0.0004	0.0010	0.0019	0.0025	0.0032	0.0033	0.0035	
		Feed (ipm)				23.5	29.3	37.2	36.7	37.6	32.3	25.7		
P	ALLOY STEELS 4140, 4150, 4320, 5120, 5150, 8630, 86L20, 50100	≤ 375 Bhn or ≤ 40 HRc		≤ 0.02	≤ 2	275	RPM	8404	4202	2801	2101	1681	1401	1051
		(220-330)				Fz	0.0003	0.0007	0.0014	0.0018	0.0023	0.0024	0.0026	
		Feed (ipm)				10.1	11.8	15.7	15.1	15.5	13.4	10.9		
M	STAINLESS STEELS (FREE MACHINING) 303, 416, 420F, 430F, 440F	≤ 275 Bhn or ≤ 28 HRc		≤ 0.02	≤ 2	420	RPM	12835	6418	4278	3209	2567	2139	1604
		(336-504)				Fz	0.0004	0.0010	0.0019	0.0025	0.0032	0.0033	0.0035	
		Feed (ipm)				20.5	25.7	32.5	32.1	32.9	28.2	22.5		
M	STAINLESS STEELS (DIFFICULT) 304, 304L, 316, 316L	≤ 275 Bhn or ≤ 28 HRc		≤ 0.02	≤ 2	290	RPM	8862	4431	2954	2216	1772	1477	1108
		(232-348)				Fz	0.0003	0.0007	0.0014	0.0018	0.0023	0.0024	0.0026	
		Feed (ipm)				10.6	12.4	16.5	16.0	16.3	14.2	11.5		
M	STAINLESS STEELS (PH) 13-8 PH, 15-5 PH, 17-4 PH, Custom 450	≤ 325 Bhn or ≤ 35 HRc		≤ 0.02	≤ 2	265	RPM	8098	4049	2699	2025	1620	1350	1012
		(212-318)				Fz	0.0003	0.0007	0.0014	0.0018	0.0023	0.0024	0.0026	
		Feed (ipm)				9.7	11.3	15.1	14.6	14.9	13.0	10.5		
K	CAST IRONS (LOW & MEDIUM ALLOY) Gray, Malleable, Ductile	≤ 220 Bhn or ≤ 19 HRc		≤ 0.02	≤ 2	605	RPM	18489	9244	6163	4622	3698	3081	2311
		(484-726)				Fz	0.0006	0.0015	0.0028	0.0037	0.0046	0.0047	0.0051	
		Feed (ipm)				44.4	55.5	69.0	68.4	68.0	57.9	47.1		
K	CAST IRONS (HIGH ALLOY) Gray, Malleable, Ductile	≤ 260 Bhn or ≤ 26 HRc		≤ 0.02	≤ 2	465	RPM	14210	7105	4737	3553	2842	2368	1776
		(372-558)				Fz	0.0004	0.0011	0.0021	0.0028	0.0034	0.0036	0.0039	
		Feed (ipm)				22.7	31.3	39.8	39.8	38.7	34.1	27.7		
S	SUPER ALLOYS (NICKEL, COBALT, IRON BASE) Inconel 601, 617, 625, Incoloy, Monel 400	≤ 300 Bhn or ≤ 32 HRc		≤ 0.02	≤ 2	80	RPM	2445	1222	815	611	489	407	306
		(64-96)				Fz	0.0003	0.0007	0.0014	0.0018	0.0023	0.0024	0.0026	
		Feed (ipm)				2.9	3.4	4.6	4.4	4.5	3.9	3.2		
S	SUPER ALLOYS (NICKEL, COBALT, IRON BASE) Inconel 718, X-750, Incoloy, Waspaloy, Hastelloy, Rene	≤ 400 Bhn or ≤ 43 HRc		≤ 0.02	≤ 2	65	RPM	1986	993	662	497	397	331	248
		(52-78)				Fz	0.0002	0.0006	0.0010	0.0014	0.0017	0.0018	0.0019	
		Feed (ipm)				1.6	2.4	2.6	2.8	2.7	2.4	1.9		
S	TITANIUM ALLOYS Pure Titanium, Ti6Al4V, Ti6Al2Sn4Zr2Mo, Ti4Al4Mo2Sn0.5Si	≤ 350 Bhn or ≤ 38 HRc		≤ 0.02	≤ 2	300	RPM	9168	4584	3056	2292	1834	1528	1146
		(240-360)				Fz	0.0004	0.0011	0.0021	0.0028	0.0034	0.0036	0.0039	
		Feed (ipm)				14.7	20.2	25.7	25.7	24.9	22.0	17.9		
S	TITANIUM ALLOYS (DIFFICULT) Ti10Al2Fe3Al, Ti5Al5V5Mo3Cr, Ti7Al4Mo, Ti3Al8V6Cr4Zr4Mo, Ti6Al6V6Sn, Ti15V3 Cr3Sn3Al	≤ 440 Bhn or ≤ 47 HRc		≤ 0.02	≤ 2	105	RPM	3209	1604	1070	802	642	535	401
		(84-126)				Fz	0.0004	0.0011	0.0021	0.0028	0.0034	0.0036	0.0039	
		Feed (ipm)				5.1	7.1	9.0	9.0	8.7	7.7	6.3		
H	TOOL STEELS A2, D2, H13, L2, M2, P20, S7, T15, W2	≤ 375 Bhn or ≤ 40 HRc		≤ 0.02	≤ 2	230	RPM	7029	3514	2343	1757	1406	1171	879
		(184-276)				Fz	0.0002	0.0006	0.0012	0.0016	0.0020	0.0021	0.0022	
		Feed (ipm)				5.6	8.4	11.2	11.2	11.2	9.8	7.7		

Bhn (Brinell) HRc (Rockwell C)

$rpm = Vc \times 3.82 / DC$

$ipm = Fz \times 4 \times rpm$

reduce speed and feed for materials harder than listed

feed rates listed have chip thinning adjustments included where applicable

refer to the SGS Tool Wizard® for complete technical information (www.kyocera-sgtool.com)

Series 7

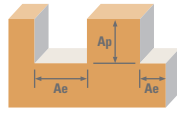

Series 7M, 7MB Metric	Hardness	Finish	Ae x DC	Ap x DC	Vc (m/min)	DC • mm									
						3	6	8	10	12	16	20	25		
P	CARBON STEELS 1018, 1040, 1080, 1090, 10L50, 1140, 1212, 12L15, 1525, 1536	≤ 275 Bhn or ≤ 28 HRc	Finish	≤ 0.02	≤ 2	146	RPM	15511	7755	5816	4653	3878	2908	2327	1861
						(117-176)	Fz	0.0166	0.043	0.075	0.093	0.110	0.125	0.147	0.160
						Feed (mm/min)	1030	1334	1745	1731	1706	1454	1368	1191	
ALLOY STEELS 4140, 4150, 4320, 5120, 5150, 8630, 86L20, 50100	≤ 375 Bhn or ≤ 40 HRc	Finish	≤ 0.02	≤ 2	84	RPM	8886	4443	3332	2666	2222	1666	1333	1066	
						(67-101)	Fz	0.0122	0.034	0.051	0.069	0.082	0.091	0.109	0.120
						Feed (mm/min)	434	604	680	736	729	606	581	512	
M	STAINLESS STEELS (FREE MACHINING) 303, 416, 420F, 430F, 440F	≤ 275 Bhn or ≤ 28 HRc	Finish	≤ 0.02	≤ 2	128	RPM	13572	6786	5089	4072	3393	2545	2036	1629
						(102-154)	Fz	0.0086	0.024	0.040	0.048	0.058	0.065	0.077	0.087
						Feed (mm/min)	467	651	814	782	787	662	627	567	
STAINLESS STEELS (DIFFICULT) 304, 304L, 316, 316L	≤ 275 Bhn or ≤ 28 HRc	Finish	≤ 0.02	≤ 2	88	RPM	9371	4686	3514	2811	2343	1757	1406	1125	
						(71-106)	Fz	0.0082	0.022	0.037	0.045	0.048	0.060	0.072	0.078
						Feed (mm/min)	307	412	520	506	450	422	405	351	
STAINLESS STEELS (PH) 13-8 PH, 15-5 PH, 17-4 PH, Custom 450	≤ 325 Bhn or ≤ 35 HRc	Finish	≤ 0.02	≤ 2	81	RPM	8563	4282	3211	2569	2141	1606	1284	1028	
						(65-97)	Fz	0.0070	0.019	0.029	0.040	0.048	0.055	0.064	0.070
						Feed (mm/min)	240	325	372	411	411	353	329	288	
K	CAST IRONS (LOW & MEDIUM ALLOY) Gray, Malleable, Ductile	≤ 220 Bhn or ≤ 19 HRc	Finish	≤ 0.02	≤ 2	184	RPM	19550	9775	7331	5865	4887	3666	2932	2346
						(148-221)	Fz	0.0132	0.036	0.052	0.075	0.089	0.099	0.117	0.130
						Feed (mm/min)	1032	1408	1525	1759	1740	1452	1372	1220	
CAST IRONS (HIGH ALLOY) Gray, Malleable, Ductile	≤ 260 Bhn or ≤ 26 HRc	Finish	≤ 0.02	≤ 2	142	RPM	15026	7513	5635	4508	3756	2817	2254	1803	
						(113-170)	Fz	0.0132	0.036	0.052	0.075	0.089	0.099	0.117	0.130
						Feed (mm/min)	793	1082	1172	1352	1337	1116	1055	938	
S	SUPER ALLOYS (NICKEL, COBALT, IRON BASE) Inconel 601, 617, 625, Incoloy, Monel 400	≤ 300 Bhn or ≤ 32 HRc	Finish	≤ 0.02	≤ 2	24	RPM	2585	1293	969	776	646	485	388	310
						(20-29)	Fz	0.0072	0.019	0.029	0.037	0.046	0.053	0.061	0.085
						Feed (mm/min)	74	98	112	90	119	103	95	105	
SUPER ALLOYS (NICKEL, COBALT, IRON BASE) Inconel 718, X-750, Incoloy, Waspaloy, Hastelloy, Rene	≤ 400 Bhn or ≤ 43 HRc	Finish	≤ 0.02	≤ 2	20	RPM	2100	1050	788	630	525	394	315	252	
						(16-24)	Fz	0.0075	0.016	0.021	0.030	0.038	0.044	0.051	0.070
						Feed (mm/min)	63	67	66	76	80	69	64	71	
TITANIUM ALLOYS Pure Titanium, Ti6Al4V, Ti6Al2Sn4Zr2Mo, Ti4Al4Mo2Sn0.5Si	≤ 350 Bhn or ≤ 38 HRc	Finish	≤ 0.02	≤ 2	91	RPM	9694	4847	3635	2908	2424	1818	1454	1163	
						(73-110)	Fz	0.0091	0.024	0.040	0.050	0.060	0.070	0.080	0.088
						Feed (mm/min)	353	465	51	59	582	509	465	409	
TITANIUM ALLOYS (DIFFICULT) Ti10Al2Fe3Al, Ti5Al5V5Mo3Cr, Ti7Al4Mo, Ti3Al8V6Cr4Zr4Mo, Ti6Al6V6Sn, Ti15V3 Cr3Sn3Al	≤ 440 Bhn or ≤ 47 HRc	Finish	≤ 0.02	≤ 2	32	RPM	3393	1696	1272	1018	848	636	509	407	
						(26-38)	Fz	0.0082	0.019	0.029	0.037	0.046	0.053	0.061	0.085
						Feed (mm/min)	111	129	148	151	156	135	124	138	
H	TOOL STEELS A2, D2, H13, L2, M2, P20, S7, T15, W2	≤ 375 Bhn or ≤ 40 HRc	Finish	≤ 0.02	≤ 2	70	RPM	7432	3716	2787	2230	1858	1394	1115	892
						(56-84)	Fz	0.0070	0.019	0.040	0.043	0.048	0.057	0.064	0.070
						Feed (mm/min)	208	282	446	384	357	318	285	250	

Bhn (Brinell) HRc (Rockwell C)

$$\text{rpm} = (\text{Vc} \times 1000) / (\text{DC} \times 3.14)$$

$$\text{mm/min} = \text{Fz} \times 4 \times \text{rpm}$$

reduce speed and feed for materials harder than listed

feed rates listed have chip thinning adjustments included where applicable

refer to the SGS Tool Wizard® for complete technical information (www.kyocera-sgstool.com)

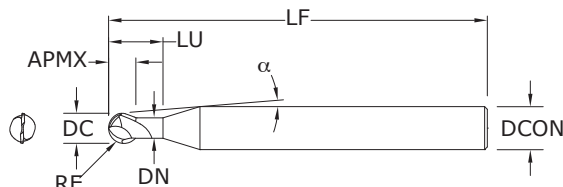
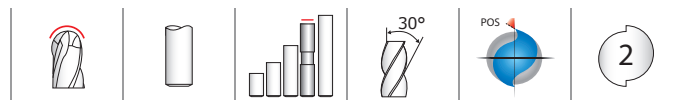

56B
FRACTIONAL SERIES

TOLERANCES (inch)

1/32–3/32 DIAMETER

DC = +0.0000/–0.0010

DCON = h_6

RE = +0.0000/–0.0005

>3/32–1/4 DIAMETER

DC = +0.0000/–0.0012

DCON = h_6

RE = +0.0000/–0.0006

>1/4–3/8 DIAMETER

DC = +0.0000/–0.0016

DCON = h_6

RE = +0.0000/–0.0008

>3/8–3/4 DIAMETER

DC = +0.0000/–0.0020

DCON = h_6

RE = +0.0000/–0.0010

HARDENED STEELS

For patent information visit www.ksptpatents.com

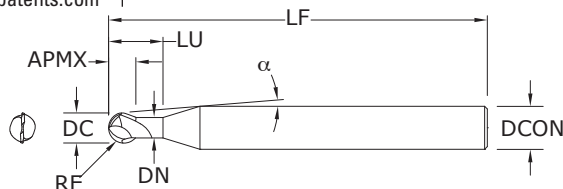

56MB
METRIC SERIES

TOLERANCES (mm)

1–2,5 DIAMETER

DC = +0,000/–0,025

DCON = h_6

RE = +0,000/–0,0013

>2,5–6 DIAMETER

DC = +0,000/–0,030

DCON = h_6

RE = +0,000/–0,0013

>6–10 DIAMETER

DC = +0,000/–0,040

DCON = h_6

RE = +0,000/–0,0020

>10–20 DIAMETER

DC = +0,000/–0,050

DCON = h_6

RE = +0,000/–0,0025

HARDENED STEELS

For patent information visit www.ksptpatents.com

	inch							EDP NO.
	CUTTING DIAMETER DC	LENGTH OF CUT APMX	OVERALL LENGTH LF	SHANK DIAMETER DCON	CENTER LINE ANGLE α	REACH LU	NECK DIAMETER DN	Ti-NAMITE-X
	1/32	1/32	3	1/4	8°20'	1/16	.025	93272
	1/16	1/16	3	1/4	7°40'	1/8	.055	93273
	3/32	3/32	3	1/4	6°50'	3/16	.085	93274
	1/8	1/8	3	1/4	6°	1/4	.114	93275
	3/16	3/16	3	1/4	3°35'	3/8	.171	93276
	1/4	1/4	3-1/2	1/4	–	1/2	.230	93277
	5/16	5/16	4	5/16	–	5/8	.292	93278
	3/8	3/8	4	3/8	–	3/4	.355	93279
	1/2	1/2	4-1/2	1/2	–	1	.480	93280
	5/8	5/8	5-1/2	5/8	–	1-1/4	.610	93281
	3/4	3/4	6-1/2	3/4	–	1-1/2	.735	93282

Neck Option Available
RE = 1/2 Cutting Diameter (DC)

- Short flute length and rigid design to reduce deflection
- S-Gash Ball geometry minimizes load and heat produced during the cutting process, ultimately enhancing tool life
- Ideal for machining complex contoured shapes in hardened steels
- Recommended for materials 35 to 60 HRc (327 to 654 Bhn)

	mm							EDP NO.
	CUTTING DIAMETER DC	LENGTH OF CUT APMX	OVERALL LENGTH LF	SHANK DIAMETER DCON	CENTER LINE ANGLE α	REACH LU	NECK DIAMETER DN	Ti-NAMITE-X
	1,0	1,0	76,0	6,0	8°10'	2,0	0,91	91349
	1,5	1,5	76,0	6,0	7°45'	3,0	1,37	91350
	2,0	2,0	76,0	6,0	7°10'	4,0	1,83	91351
	2,5	2,5	76,0	6,0	6°35'	5,0	2,29	91352
	3,0	3,0	76,0	6,0	6°	6,0	2,72	91353
	4,0	4,0	76,0	6,0	4°30'	8,0	3,63	91354
	5,0	5,0	89,0	6,0	2°30'	10,0	4,55	91355
	6,0	6,0	89,0	6,0	–	12,0	5,49	91356
	8,0	8,0	102,0	8,0	–	16,0	7,49	91357
	10,0	10,0	102,0	10,0	–	20,0	9,47	91358
	12,0	12,0	114,0	12,0	–	24,0	11,48	91359
	16,0	16,0	140,0	16,0	–	32,0	15,62	91360
	20,0	20,0	165,0	20,0	–	40,0	19,61	91361

Neck Option Available
RE = 1/2 Cutting Diameter (DC)

- Short flute length and rigid design to reduce deflection
- S-Gash Ball geometry minimizes load and heat produced during the cutting process, ultimately enhancing tool life
- Ideal for machining complex contoured shapes in hardened steels
- Recommended for materials 35 to 60 HRc (327 to 654 Bhn)

Turbo-Carb

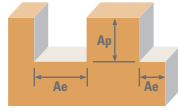

Series 56B Fractional	Hardness	Ae x DC	Ap x DC	Vc (sfm)	DC • in									
					1/32	1/16	1/8	3/16	1/4	3/8	1/2	3/4		
H	TOOL STEELS MOLD AND DIE STEEL 300M, 4340, 52100, HP-9-4-20, M50, A2, D2, H13, L2, M2, P20, S7, T15, W2 ≤ 375 Bhn or ≤ 40 HRc	Rough 	≤ 0.4	≤ 0.1	625	RPM	76400	38200	19100	12733	9550	6367	4775	3183
					(500-750)	Fz	0.0006	0.0015	0.0030	0.0040	0.0050	0.0080	0.0100	0.0120
					Feed (ipm)	92	115	115	102	96	102	96	76	
		HSM 	≤ 0.4	≤ 0.03	950	RPM	116128	58064	29032	19355	14516	9677	7258	4839
					(760-1140)	Fz	0.0007	0.0017	0.0033	0.0044	0.0060	0.0088	0.0110	0.0130
					Feed (ipm)	163	197	192	170	174	170	160	126	
	TOOL STEELS MOLD AND DIE STEEL 300M, 4340, 52100, HP-9-4-20, M50, A2, D2, H13, L2, M2, P20, S7, T15, W2 ≤ 475 Bhn or ≤ 50 HRc	Rough 	≤ 0.4	≤ 0.05	750	RPM	91680	45840	22920	15280	11460	7640	5730	3820
					(600-900)	Fz	0.0005	0.0011	0.0023	0.0030	0.0038	0.0060	0.0075	0.0085
					Feed (ipm)	92	101	105	92	87	92	86	65	
		HSM 	≤ 0.4	≤ 0.02	1150	RPM	140576	70288	35144	23429	17572	11715	8786	5857
					(920-1380)	Fz	0.0006	0.0012	0.0025	0.0033	0.0042	0.0066	0.0082	0.0100
					Feed (ipm)	169	169	176	155	148	155	144	117	
TOOL STEELS MOLD AND DIE STEEL 300M, 4340, 52100, HP-9-4-20, M50, A2, D2, H13, L2, M2, P20, S7, T15, W2 ≤ 655 Bhn or ≤ 60 HRc	Rough 	≤ 0.4	≤ 0.04	500	RPM	61120	30560	15280	10187	7640	5093	3820	2547	
				(400-600)	Fz	0.0004	0.0008	0.0017	0.0023	0.0029	0.0045	0.0057	0.0063	
				Feed (ipm)	49	49	52	47	44	46	44	32		
	HSM 	≤ 0.4	≤ 0.01	1000	RPM	122240	61120	30560	20373	15280	10187	7640	5093	
				(800-1200)	Fz	0.0005	0.0009	0.0019	0.0025	0.0032	0.0050	0.0063	0.0071	
				Feed (ipm)	122	110	116	102	98	102	96	72		

Bhn (Brinell) HRc (Rockwell C) HSM (High Speed Machining)
 rpm = Vc x 3.82 / DC
 ipm = Fz x 2 x rpm
 reduce speed and feed for materials harder than listed
 reduce feed and Ae when finish milling (.02 x DC maximum)
 feed rates listed have chip thinning adjustments included where applicable
 refer to the SGS Tool Wizard® for complete technical information (www.kyocera-sgstool.com)

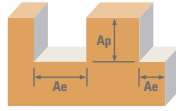

Series 56MB Metric	Hardness	Ae x DC	Ap x DC	Vc (m/min)	DC • mm									
					1	1.5	3	5	6	10	12	20		
H	TOOL STEELS MOLD AND DIE STEEL 300M, 4340, 52100, HP-9-4-20, M50, A2, D2, H13, L2, M2, P20, S7, T15, W2 ≤ 375 Bhn or ≤ 40 HRc	Rough 	≤ 0.4	≤ 0.1	191	RPM	60748	40498	20249	12150	10125	6075	5062	3037
					(153-229)	Fz	0.015	0.038	0.076	0.102	0.127	0.203	0.254	0.305
		HSM 	≤ 0.4	≤ 0.03	290	RPM	92235	61490	46117	18447	15372	9223	7686	4612
					(232-348)	Fz	0.018	0.043	0.084	0.112	0.117	0.224	0.279	0.330
		HSM 	≤ 0.4	≤ 0.03	290	RPM	92235	61490	46117	18447	15372	9223	7686	4612
					(232-348)	Feed (mm/min)	1822	3078	3078	2479	2572	2466	2572	1853
	TOOL STEELS MOLD AND DIE STEEL 300M, 4340, 52100, HP-9-4-20, M50, A2, D2, H13, L2, M2, P20, S7, T15, W2 ≤ 475 Bhn or ≤ 50 HRc	Rough 	≤ 0.4	≤ 0.05	229	RPM	72833	48556	24278	14567	12139	7283	6069	3642
					(183-275)	Fz	0.013	0.028	0.058	0.076	0.097	0.152	0.191	0.216
		HSM 	≤ 0.4	≤ 0.02	351	RPM	111636	74424	37212	22327	18606	11164	9303	5582
					(281-421)	Fz	0.015	0.030	0.064	0.084	0.107	0.168	0.208	0.254
		HSM 	≤ 0.4	≤ 0.02	351	RPM	111636	74424	37212	22327	18606	11164	9303	5582
					(281-421)	Feed (mm/min)	3349	4465	4763	3751	3982	3751	3870	2836
TOOL STEELS MOLD AND DIE STEEL 300M, 4340, 52100, HP-9-4-20, M50, A2, D2, H13, L2, M2, P20, S7, T15, W2 ≤ 655 Bhn or ≤ 60 HRc	Rough 	≤ 0.4	≤ 0.04	152	RPM	48344	32229	16115	9669	8057	4834	4029	2417	
				(122-182)	Fz	0.010	0.020	0.043	0.058	0.074	0.114	0.145	0.160	
	HSM 	≤ 0.4	≤ 0.01	305	RPM	97005	64670	32335	19401	16168	9701	8084	4850	
				(244-366)	Fz	0.013	0.023	0.048	0.064	0.081	0.127	0.160	0.180	
	HSM 	≤ 0.4	≤ 0.01	305	RPM	97005	64670	32335	19401	16168	9701	8084	4850	
				(244-366)	Feed (mm/min)	2522	2975	3104	2483	2619	2464	2587	1746	

Bhn (Brinell) HRc (Rockwell C) HSM (High Speed Machining)
 $rpm = (Vc \times 1000) / (DC \times 3.14)$
 $mm/min = Fz \times 2 \times rpm$
 reduce speed and feed for materials harder than listed
 reduce feed and Ae when finish milling (.02 x DC maximum)
 feed rates listed have chip thinning adjustments included where applicable
 refer to the SGS Tool Wizard® for complete technical information (www.kyocera-sgtool.com)

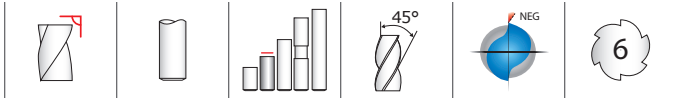

57

FRACTIONAL SERIES

- Ideal in Trochoidal milling applications in hardened steels and dry machining
- Short flute length and large core design to reduce deflection
- Unsurpassed edge strength with extreme negative rake and eccentric relief
- Recommended for materials 45 to 65 HRc (421 to 739 Bhn)

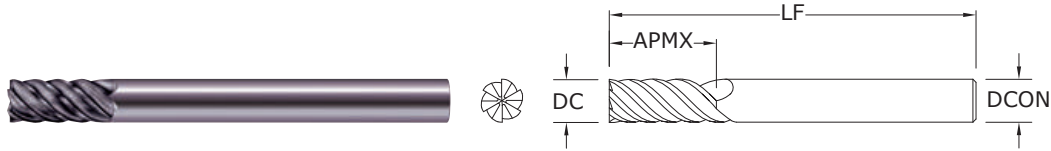

inch				EDP NO.
CUTTING DIAMETER DC	LENGTH OF CUT APMX	OVERALL LENGTH LF	SHANK DIAMETER DCON	Ti-NAMITE-X
1/4	17/32	3-1/2	1/4	36140
5/16	11/16	4	5/16	36141
3/8	13/16	4	3/8	36142
1/2	1-3/32	4-1/2	1/2	36143

Neck Option Available

TOLERANCES (inch)

- 1/4 DIAMETER**
DC = +0.0000/-0.0012
DCON = h₆
- 5/16 DIAMETER**
DC = +0.0000/-0.0016
DCON = h₆
- 3/8 DIAMETER**
DC = +0.0000/-0.0016
DCON = h₆
- 1/2 DIAMETER**
DC = +0.0000/-0.0020
DCON = h₆

HARDENED STEELS

For patent information visit www.ksptpatents.com

57M

METRIC SERIES

- Ideal in Trochoidal milling applications in hardened steels and dry machining
- Short flute length and large core design to reduce deflection
- Unsurpassed edge strength with extreme negative rake and eccentric relief
- Recommended for materials 45 to 65 HRc (421 to 739 Bhn)

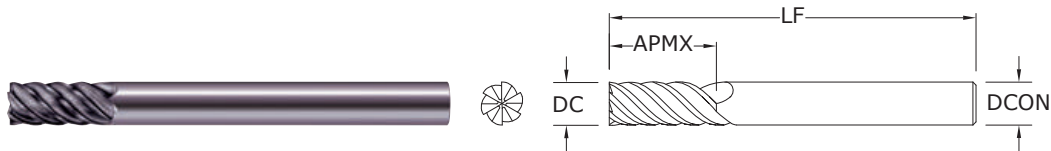

mm				EDP NO.
CUTTING DIAMETER DC	LENGTH OF CUT APMX	OVERALL LENGTH LF	SHANK DIAMETER DCON	Ti-NAMITE-X
6,0	13,0	89,0	6,0	46140
8,0	18,0	102,0	8,0	46141
10,0	22,0	102,0	10,0	46142
12,0	26,0	114,0	12,0	46143
16,0	32,0	140,0	16,0	46145
20,0	38,0	165,0	20,0	46147

Neck Option Available







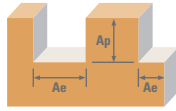

TOLERANCES (mm)

- 6 DIAMETER**
DC = +0,000/-0,030
DCON = h₆
- 8 DIAMETER**
DC = +0,000/-0,040
DCON = h₆
- 10 DIAMETER**
DC = +0,000/-0,040
DCON = h₆
- 12-20 DIAMETER**
DC = +0,000/-0,050
DCON = h₆

HARDENED STEELS

For patent information visit www.ksptpatents.com



Series 57 Fractional	Hardness	Ae x DC	Ap x DC	Vc (sfm)	DC • in								
					1/4	5/16	3/8	1/2					
TOOL STEELS MOLD AND DIE STEEL 300M, 4340, 52100, HP-9-4-20, M50, A2, D2, H13, L2, M2, P20, S7, T15, W2	≤ 420 Bhn or ≤ 45 HRc	Slot 	1	≤ 0.3	215	RPM	3285	2628	2190	1643			
					(172-258)	Fz	0.0013	0.0019	0.0025	0.0031			
						Feed (ipm)	26	30	33	31			
						265	RPM	4049	3239	2699	2025		
					(212-318)	Fz	0.0018	0.0026	0.0035	0.0044			
						Feed (ipm)	44	51	57	53			
	HSM 	≤ 0.04	≤ 1.5	560		RPM	8557	6845	5705	4278			
				(448-672)	Fz	0.0022	0.0033	0.0044	0.0055				
					Feed (ipm)	113	136	151	141				
	TOOL STEELS MOLD AND DIE STEEL 300M, 4340, 52100, HP-9-4-20, M50, A2, D2, H13, L2, M2, P20, S7, T15, W2	≤ 560 Bhn or ≤ 55 HRc	Slot 	1	≤ 0.3	120	RPM	1834	1467	1222	917		
						(96-144)	Fz	0.0010	0.0015	0.0020	0.0025		
							Feed (ipm)	11	13	15	14		
Profile 							≤ 0.1	≤ 1.5	150	RPM	2292	1834	1528
						(120-180)			Fz	0.0014	0.0021	0.0028	0.0035
									Feed (ipm)	19	23	26	24
HSM 		≤ 0.04	≤ 1.5	490	RPM	7487	5990	4991	3744				
				(392-588)	Fz	0.0018	0.0026	0.0035	0.0044				
					Feed (ipm)	81	93	105	99				
TOOL STEELS MOLD AND DIE STEEL 300M, 4340, 52100, HP-9-4-20, M50, A2, D2, H13, L2, M2, P20, S7, T15, W2		≤ 740 Bhn or ≤ 65 HRc	Slot 	1	≤ 0.3	65	RPM	993	795	662	497		
						(52-78)	Fz	0.0008	0.0011	0.0015	0.0019		
							Feed (ipm)	5	5	6	6		
	Profile 						≤ 0.1	≤ 1.5	80	RPM	1222	978	815
						(64-96)			Fz	0.0011	0.0016	0.0021	0.0026
									Feed (ipm)	8	9	10	10
	HSM 	≤ 0.04	≤ 1.5	250	RPM	3820	3056	2547	1910				
				(200-300)	Fz	0.0013	0.0019	0.0025	0.0031				
					Feed (ipm)	30	35	38	36				

Bhn (Brinell) HRc (Rockwell C) HSM (High Speed Machining)
 rpm = Vc x 3.82 / DC
 ipm = Fz x 6 x rpm
 reduce speed and feed for materials harder than listed
 reduce feed and Ae when finish milling (.02 x DC maximum)
 feed rates listed have chip thinning adjustments included where applicable
 refer to the SGS Tool Wizard® for complete technical information (www.kyocera-sgstool.com)

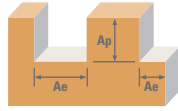

Series 57M	Metric	Hardness	Ae x DC	Ap x DC	Vc (m/min)	DC • mm										
						6	8	10	12	16	20					
TOOL STEELS MOLD AND DIE STEEL 300M, 4340, 52100, HP-9-4-20, M50, A2, D2, H13, L2, M2, P20, S7, T15, W2	Slot	≤ 420 Bhn or ≤ 45 HRc	1	≤ 0.3	66	RPM	3499	2624	2099	1749	1312	1050				
					(53-79)	Fz	0.032	0.048	0.064	0.079	0.094	0.109				
					Feed (mm/min)	672	756	806	829	740	686					
					81	RPM	4294	3220	2576	2147	1610	1288				
					(65-97)	Fz	0.046	0.066	0.089	0.112	0.132	0.152				
					Feed (mm/min)	1185	1275	1376	1443	1275	1175					
	HSM	≤ 0.04	≤ 1.5	171	RPM	9064	6798	5439	4532	3399	2719					
				(137-205)	Fz	0.056	0.084	0.112	0.140	0.170	0.200					
				Feed (mm/min)	3046	3426	3655	3807	3467	3263						
				TOOL STEELS MOLD AND DIE STEEL 300M, 4340, 52100, HP-9-4-20, M50, A2, D2, H13, L2, M2, P20, S7, T15, W2	Slot	≤ 560 Bhn or ≤ 55 HRc	1	≤ 0.3	37	RPM	1961	1471	1177	981	735	588
									(30-44)	Fz	0.025	0.038	0.051	0.064	0.077	0.090
									Feed (mm/min)	294	335	360	377	340	318	
46	RPM	2438	1829						1463	1219	914	732				
(37-55)	Fz	0.036	0.053						0.071	0.089	0.107	0.125				
Feed (mm/min)	527	582	623						651	587	549					
HSM	≤ 0.04	≤ 1.5	149	RPM	7898	5924	4739	3949	2962	2369						
			(119-179)	Fz	0.046	0.066	0.089	0.112	0.135	0.158						
			Feed (mm/min)	2180	2346	2531	2654	2399	2246							
			TOOL STEELS MOLD AND DIE STEEL 300M, 4340, 52100, HP-9-4-20, M50, A2, D2, H13, L2, M2, P20, S7, T15, W2	Slot	≤ 740 Bhn or ≤ 65 HRc	1	≤ 0.3	20	RPM	1060	795	636	530	398	318	
								(16-24)	Fz	0.020	0.028	0.038	0.048	0.058	0.068	
								Feed (mm/min)	127	134	145	153	138	130		
24	RPM	1272						954	763	636	477	382				
(19-29)	Fz	0.028						0.041	0.053	0.066	0.078	0.090				
Feed (mm/min)	214	235						243	252	223	206					
HSM	≤ 0.04	≤ 1.5	76	RPM	4029	3021	2417	2014	1511	1209						
			(61-91)	Fz	0.033	0.048	0.064	0.079	0.094	0.109						
			Feed (mm/min)	798	870	928	955	852	790							

Bhn (Brinell) HRc (Rockwell C) HSM (High Speed Machining)
 rpm = (Vc x 1000) / (DC x 3.14)
 mm/min = Fz x 6 x rpm
 reduce speed and feed for materials harder than listed
 reduce feed and Ae when finish milling (.02 x DC maximum)
 feed rates listed have chip thinning adjustments included where applicable
 refer to the SGS Tool Wizard® for complete technical information (www.kyocera-sgstool.com)

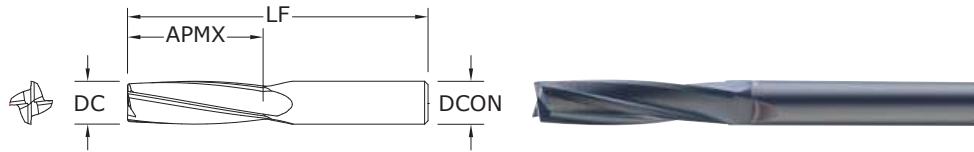

27
FRACTIONAL SERIES

TOLERANCES (inch)

DC = +0.0000/-0.0030
DCON = h_6

PLASTICS/COMPOSITES

For patent information visit www.ksptpatents.com

CUTTING DIAMETER DC	LENGTH OF CUT APMX	OVERALL LENGTH LF	SHANK DIAMETER DCON	EDP NO.	
				UNCOATED	Di-NAMITE® (Diamond)
1/4	1	2-1/2	1/4	72978	72979
3/8	1-1/8	2-1/2	3/8	72980	72981
1/2	1-1/2	3-1/2	1/2	72982	72983
3/4	1-3/8	4	3/4	72984	72985

- Slow helix design adds strength to the edge allowing ease for milling highly abrasive materials
- Two levels of chatter suppression: variable helix and indexing
- Excels at roughing (slotting, profiling) and finishing in a variety of plastics and composites

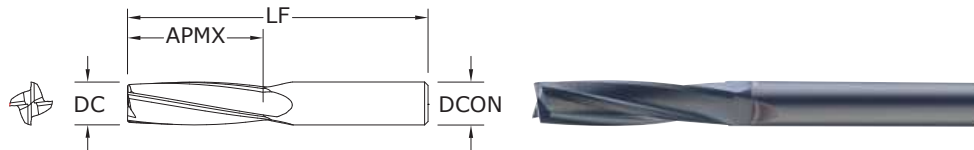

27M
METRIC SERIES

TOLERANCES (mm)

DC = +0,000/-0,080
DCON = h_6

PLASTICS/COMPOSITES

For patent information visit www.ksptpatents.com

CUTTING DIAMETER DC	LENGTH OF CUT APMX	OVERALL LENGTH LF	SHANK DIAMETER DCON	EDP NO.	
				UNCOATED	Di-NAMITE® (Diamond)
6,0	25,0	63,0	6,0	83056	83057
8,0	25,0	63,0	8,0	83058	83059
10,0	28,0	63,0	10,0	83060	83061
12,0	38,0	89,0	12,0	83062	83063
16,0	48,0	115,0	16,0	83064	83065

- Slow helix design adds strength to the edge allowing ease for milling highly abrasive materials
- Two levels of chatter suppression: variable helix and indexing
- Excels at roughing (slotting, profiling) and finishing in a variety of plastics and composites

FRACTIONAL Series 27

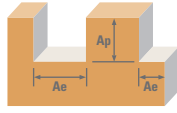

Series 27 Fractional			Vc (sfm)	DC • in				
	Ae x DC	Ap x DC		1/4	3/8	1/2	3/4	
CFRP, AFRP (CARBON FIBER, ARAMID FIBER)	Slot 	1 ≤ 1	400	RPM	6112	4075	3056	2037
			(320-480)	Fz	0.0016	0.0030	0.0040	0.0048
				Feed (ipm)	39	49	49	39
	Profile 	≤ 0.5 ≤ 1.5	500	RPM	7640	5093	3820	2547
			(400-600)	Fz	0.0016	0.0030	0.0040	0.0048
				Feed (ipm)	49	61	61	49
	HSM 	≤ 0.5 ≤ 2	825	RPM	12606	8404	6303	4202
			(660-990)	Fz	0.0037	0.0069	0.0092	0.0110
				Feed (ipm)	187	232	232	185
GFRP (FIBERGLASS)	Slot 	1 ≤ 1	320	RPM	4890	3260	2445	1630
			(256-384)	Fz	0.0016	0.0030	0.0040	0.0048
				Feed (ipm)	31	39	39	31
	Profile 	≤ 0.5 ≤ 1.5	400	RPM	6112	4075	3056	2037
			(320-480)	Fz	0.0016	0.0030	0.0040	0.0048
				Feed (ipm)	39	49	49	39
	HSM 	≤ 0.5 ≤ 2	660	RPM	10085	6723	5042	3362
			(528-792)	Fz	0.0037	0.0069	0.0092	0.0110
				Feed (ipm)	149	186	186	148
N CARBON, GRAPHITE	Slot 	1 ≤ 1	480	RPM	7334	4890	3667	2445
			(384-576)	Fz	0.0020	0.0038	0.0050	0.0060
				Feed (ipm)	59	74	73	59
	Profile 	≤ 0.5 ≤ 1.5	600	RPM	9168	6112	4584	3056
			(480-720)	Fz	0.0020	0.0038	0.0050	0.0060
				Feed (ipm)	73	93	92	73
	HSM 	≤ 0.5 ≤ 2	990	RPM	15127	10085	7564	5042
			(792-1188)	Fz	0.0046	0.0086	0.0115	0.0138
				Feed (ipm)	278	347	348	278
PLASTICS	Slot 	1 ≤ 1	800	RPM	12224	8149	6112	4075
			(640-690)	Fz	0.0020	0.0038	0.0050	0.0060
				Feed (ipm)	98	124	122	98
	Profile 	≤ 0.5 ≤ 1.5	1000	RPM	15280	10187	7640	5093
			(800-1200)	Fz	0.0020	0.0038	0.0050	0.0060
				Feed (ipm)	122	155	153	122
	HSM 	≤ 0.5 ≤ 2	1650	RPM	25212	16808	12606	8404
			(1320-1980)	Fz	0.0046	0.0086	0.0115	0.0138
				Feed (ipm)	464	578	580	464
MACHINABLE CERAMICS MACHINABLE GLASS	Slot 	1 ≤ 1	40	RPM	611	407	306	204
			(32-48)	Fz	0.0008	0.0015	0.0020	0.0024
				Feed (ipm)	2.0	2.4	2.4	2.0
	Profile 	≤ 0.5 ≤ 1.5	50	RPM	764	509	382	255
			(40-60)	Fz	0.0008	0.0015	0.0020	0.0024
				Feed (ipm)	2.4	3.1	3.1	2.4
	HSM 	≤ 0.5 ≤ 2	85	RPM	1299	866	649	433
			(68-102)	Fz	0.0018	0.0034	0.0046	0.0055
				Feed (ipm)	9.4	11.8	11.9	9.5

HSM (High Speed Machining)
 $rpm = Vc \times 3.82 / DC$
 $ipm = Fz \times 4 \times rpm$
 adjust parameters based on resin type and fiber structure
 reduce speed when overheating causes melting or damage to resin
 reduce feed if delamination or fraying occur
 finish cuts typically required reduced feed and cutting depths

rates shown are for use without coolant; rates may be increased with coolant
 dust collection is vital when machining dry
 diamond coating will increase tool life in graphite and composite materials
 feed rates listed have chip thinning adjustments included where applicable
 refer to the SGS Tool Wizard® for complete technical information
 (www.kyocera-sgstool.com)

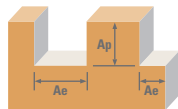

Series 27M Metric	Ae x DC	Ap x DC	Vc (m/min)	DC • mm						
				6	8	10	12	16		
CFRP, AFRP (CARBON FIBER, ARAMID FIBER)	Slot 	1	≤ 1	120	RPM	6361	4771	3817	3181	2385
					Fz	0.040	0.065	0.075	0.100	0.120
					Feed (mm/min)	1018	1240	1145	1272	1145
	Profile 	≤ 0.5	≤ 1.5	150	RPM	7951	5963	4771	3976	2982
					Fz	0.040	0.065	0.075	0.100	0.120
					Feed (mm/min)	1272	1550	1431	1590	1431
	HSM 	≤ 0.5	≤ 2	250	RPM	13252	9939	7951	6626	4970
					Fz	0.095	0.145	0.175	0.235	0.280
					Feed (mm/min)	5036	5765	5566	6228	5566
GFRP (FIBERGLASS)	Slot 	1	≤ 1	100	RPM	5301	3976	3181	2650	1988
					Fz	0.040	0.065	0.075	0.100	0.120
					Feed (mm/min)	848	1034	954	1060	954
	Profile 	≤ 0.5	≤ 1.5	120	RPM	6361	4771	3817	3181	2385
					Fz	0.040	0.065	0.075	0.100	0.120
					Feed (mm/min)	1018	1240	1145	1272	1145
	HSM 	≤ 0.5	≤ 2	200	RPM	10602	7951	6361	5301	3976
					Fz	0.095	0.145	0.175	0.235	0.280
					Feed (mm/min)	4029	4612	4453	4983	4453
N CARBON, GRAPHITE	Slot 	1	≤ 1	145	RPM	7686	5765	4612	3843	2882
					Fz	0.050	0.080	0.095	0.125	0.150
					Feed (mm/min)	1537	1845	1752	1922	1729
	Profile 	≤ 0.5	≤ 1.5	185	RPM	9807	7355	5884	4903	3677
					Fz	0.050	0.080	0.095	0.125	0.150
					Feed (mm/min)	1961	2354	2236	2452	2206
	HSM 	≤ 0.5	≤ 2	300	RPM	15903	11927	9542	7951	5963
					Fz	0.115	0.185	0.220	0.290	0.350
					Feed (mm/min)	7315	8826	8397	9223	8349
PLASTICS	Slot 	1	≤ 1	245	RPM	12987	9740	7792	6494	4870
					Fz	0.050	0.080	0.095	0.125	0.150
					Feed (mm/min)	2597	3117	2961	3247	2922
	Profile 	≤ 0.5	≤ 1.5	305	RPM	16168	12126	9701	8084	6063
					Fz	0.050	0.080	0.095	0.125	0.150
					Feed (mm/min)	3234	3880	3686	4042	3638
	HSM 	≤ 0.5	≤ 2	505	RPM	26769	20077	16062	13385	10038
					Fz	0.115	0.185	0.220	0.290	0.350
					Feed (mm/min)	12314	14857	14134	15526	14054
MACHINABLE CERAMICS MACHINABLE GLASS	Slot 	1	≤ 1	10	RPM	530	398	318	265	199
					Fz	0.020	0.035	0.045	0.050	0.060
					Feed (mm/min)	42	56	57	53	48
	Profile 	≤ 0.5	≤ 1.5	15	RPM	795	596	477	398	298
					Fz	0.020	0.035	0.045	0.050	0.060
					Feed (mm/min)	64	83	86	80	72
	HSM 	≤ 0.5	≤ 2	25	RPM	1325	994	795	663	497
					Fz	0.045	0.075	0.085	0.115	0.140
					Feed (mm/min)	239	298	270	305	278

HSM (High Speed Machining)
 $rpm = Vc \times 3.82 / DC$
 $mm/min = Fz \times 4 \times rpm$
 adjust parameters based on resin type and fiber structure
 reduce speed when overheating causes melting or damage to resin
 reduce feed if delamination or fraying occur
 finish cuts typically require reduced feed and cutting depths

rates shown are for use without coolant; rates may be increased with coolant
 dust collection is vital when machining dry
 diamond coating will increase tool life in graphite and composite materials
 feed rates listed have chip thinning adjustments included where applicable
 refer to the SGS Tool Wizard® for complete technical information
 (www.kyocera-sgstoool.com)

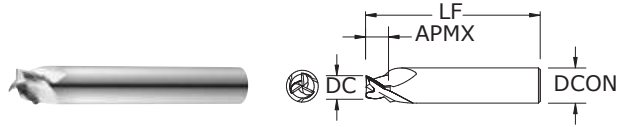
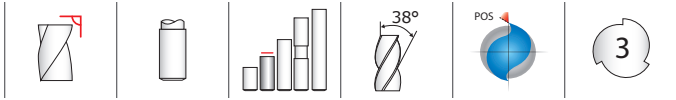

Non-Ferrous Recoil Groove Tool

FRACTIONAL SERIES

- Open Flute design improves chip removal at high feed rates.
- Circular land improves surface finish and chatter suppression.
- Symmetrical end gashing improves balance in high speed operations.
- 45 degree chamfer enables slot and deburr in one operation.
- Meets MIL-STD 1913.

CUTTING DIAMETER DC	inch			EDP NO.	
	SHANK DIAMETER DCON	LENGTH OF CUT APMX	OVERALL LENGTH LF	UNCOATED	Ti-NAMITE-B (TiB ₂)
0.2100	1/4	0.118	1-3/4	34760	34761

TOLERANCES (inch)

DC = +0.0080/-0.0000

APMX = +0.0060/-0.0000

DCON = h₆

NON-FERROUS

For patent information visit www.ksptpatents.com

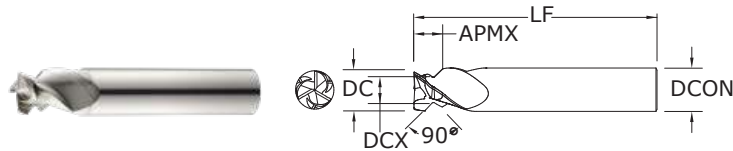
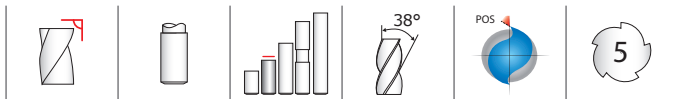

Non-Ferrous Dovetail Form Tool

FRACTIONAL SERIES

- Open Flute design improves chip removal at high feed rates.
- Specially engineered flute shape for improved chip control.
- Circular land improves surface finish and chatter suppression.
- Symmetrical end gashing improves balance in high speed operations.
- Meets MIL-STD 1913.

CUTTING DIAMETER DC	INNER CUTTING DIAMETER DCX	inch			EDP NO.	
		SHANK DIAMETER DCON	LENGTH OF CUT APMX	OVERALL LENGTH LF	UNCOATED	Ti-NAMITE-B (TiB ₂)
0.6050	0.384	5/8	0.410	3-1/2	34762	34763

TOLERANCES (inch)

DC = +0.0010/-0.0010

DCON = h₆

NON-FERROUS

For patent information visit www.ksptpatents.com

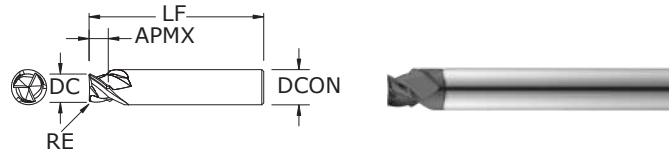
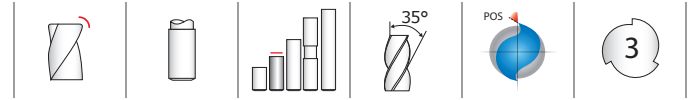

Ferrous Recoil Groove Tool

FRACTIONAL SERIES

TOLERANCES (inch)

DC = +0.0080/-0.0000

APMX = +0.0060/-0.0000

DCON = h_6

RE = +0.0000/-0.0005

- STEELS
- STAINLESS STEELS
- TITANIUM
- HARDENED STEELS

For patent information visit www.ksptpatents.com

CUTTING DIAMETER DC	SHANK DIAMETER DCON	inch			EDP NO.	
		LENGTH OF CUT APMX	OVERALL LENGTH LF	CORNER RADIUS RE	Ti-NAMITE-A (TA)	Ti-NAMITE-M (TM)
0.2100	1/4	0.118	1-3/4	.010	33360	33361

- Heavy core design adds rigidity for cutting difficult to machine materials.
- Tight corner radius tangency tolerance for quality recoil grooves.
- Specially engineered flute design adds strength and improves chip flow.
- Meets MIL-STD 1913.

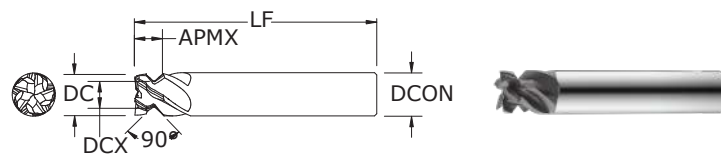

Ferrous Dovetail Form Tool

FRACTIONAL SERIES

TOLERANCES (inch)

DC = +0.0010/-0.0010

DCON = h_6

- STEELS
- STAINLESS STEELS
- TITANIUM
- HARDENED STEELS

For patent information visit www.ksptpatents.com

CUTTING DIAMETER DC	INNER CUTTING DIAMETER DCX	inch			EDP NO.	
		SHANK DIAMETER DCON	LENGTH OF CUT APMX	OVERALL LENGTH LF	Ti-NAMITE-A (TA)	Ti-NAMITE-M (TM)
0.6050	0.384	5/8	0.410	3-1/2	37391	37390

- Five-flute design allows for higher machining parameters.
- Open end work design allows for increased chip space.
- Square end configuration with enhanced corner strength to improve corner durability.
- Meets MIL-STD 1913.

Picatinny Rail Ferrous Recoil Groove Tool

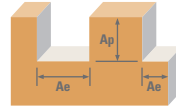

Picatinny Rail Ferrous Recoil Groove Tool 3 Flute Made to MIL-STD-1913			Hardness	Ae x DC	Ap x DC	Vc (sfm)	DC • in 0.2100
P	CARBON STEELS 1018, 1040, 1080, 1090, 10L50, 1140, 1212, 12L15, 1525, 1536	≤ 275 Bhn or ≤ 28 HRc	Slot 	0.210	0.118	440 (352-528)	RPM 8004
							Fz 0.0009
							Feed (ipm) 22.99
M	ALLOY STEELS 4140, 4150, 4320, 5120, 5150, 8630, 86L20, 50100	≤ 375 Bhn or ≤ 40 HRc	Slot 	0.210	0.118	250 (200-300)	RPM 4548
							Fz 0.0006
							Feed (ipm) 9.79
M	STAINLESS STEELS (FREE MACHINING) 303, 416, 420F, 430F, 440F	≤ 275 Bhn or ≤ 28 HRc	Slot 	0.210	0.118	390 (312-468)	RPM 7094
							Fz 0.0007
							Feed (ipm) 17.01
M	STAINLESS STEELS (DIFFICULT) 304, 304L, 316, 316L	≤ 275 Bhn or ≤ 28 HRc	Slot 	0.210	0.118	270 (216-324)	RPM 4911
							Fz 0.0006
							Feed (ipm) 9.41
M	STAINLESS STEELS (PH) 13-8 PH, 15-5 PH, 17-4 PH, Custom 450	≤ 325 Bhn or ≤ 35 HRc	Slot 	0.210	0.118	250 (200-300)	RPM 4548
							Fz 0.0006
							Feed (ipm) 8.74
K	CAST IRONS (LOW & MEDIUM ALLOY) Gray, Malleable, Ductile	≤ 220 Bhn or ≤ 19 HRc	Slot 	0.210	0.118	270 (216-324)	RPM 4911
							Fz 0.0006
							Feed (ipm) 9.41
N	ALUMINUM ALLOYS 2017, 2024, 356, 6061, 7075 Tool not recommended for this material group						
	ALUMINUM DIE CAST ALLOYS (HIGH SILICONE) A-390, A-392, B-390 Tool not recommended for this material group						
	COPPER ALLOYS Alum Bronze, C110, Muntz Brass Tool not recommended for this material group						
S	PLASTICS Polycarbonate, PVC, Polypropylene Tool not recommended for this material group						
	SUPER ALLOYS (NICKEL, COBALT, IRON BASE) Inconel 601, 617, 625, Incoloy, Monel 400	≤ 300 Bhn or ≤ 32 HRc	Slot 	0.210	0.118	65 (52-78)	RPM 1182
							Fz 0.0005
Feed (ipm) 2.00							
S	SUPER ALLOYS (NICKEL, COBALT, IRON BASE) Inconel 718, X-750, Incoloy, Waspaloy, Hastelloy, Rene	≤ 400 Bhn or ≤ 43 HRc	Slot 	0.210	0.118	49 (39-59)	RPM 891
							Fz 0.0004
							Feed (ipm) 1.05
S	TITANIUM ALLOYS Pure Titanium, Ti6Al4V, Ti6Al2Sn4Zr2Mo, Ti4Al4Mo2Sn0.5Si	≤ 350 Bhn or ≤ 38 HRc	Slot 	0.210	0.118	170 (136-204)	RPM 3092
							Fz 0.0006
							Feed (ipm) 5.89
S	TITANIUM ALLOYS (DIFFICULT) Ti10Al2Fe3Al, Ti5Al5V5Mo3Cr, Ti7Al4Mo, Ti3Al8V6Cr4Zr4Mo, Ti6Al6V6Sn, Ti15V3 Cr3Sn3Al	≤ 440 Bhn or ≤ 47 HRc	Slot 	0.210	0.118	60 (48-72)	RPM 1091
							Fz 0.0006
							Feed (ipm) 2.09
H	TOOL STEELS A2, D2, H13, L2, M2, P20, S7, T15, W2	≤ 375 Bhn or ≤ 40 HRc	Slot 	0.210	0.118	145 (116-174)	RPM 2638
							Fz 0.0005
							Feed (ipm) 4.47

Bhn (Brinell) HRc (Rockwell C)
 when recommended speed exceeds your capability, use maximum available and recalculate ipm
 $rpm = Vc \times 3.82 / DC$
 $ipm = Fz \times 3 \times rpm$
 reduce speed and feed for materials harder than listed
 reduce feed and Ae when finish milling (.02 x DC maximum)
 refer to the SGS Tool Wizard® for complete technical information (www.kyocera-sgstool.com)



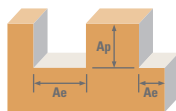

Picatinny Rail Non-Ferrous Recoil Groove Tool

Picatinny Rail
Non-Ferrous Recoil
Groove Tool
3 Flute
Made to MIL-STD-1913



DC • in

0.2100

	Hardness		Ae x DC	Ap x DC	Vc (sfm)		
P	CARBON STEELS 1018, 1040, 1080, 1090, 10L50, 1140, 1212, 12L15, 1525, 1536					Tool not recommended for this material group	
	ALLOY STEELS 4140, 4150, 4320, 5120, 5150, 8630, 86L20, 50100					Tool not recommended for this material group	
M	STAINLESS STEELS (FREE MACHINING) 303, 416, 420F, 430F, 440F					Tool not recommended for this material group	
	STAINLESS STEELS (DIFFICULT) 304, 304L, 316, 316L					Tool not recommended for this material group	
	STAINLESS STEELS (PH) 13-8 PH, 15-5 PH, 17-4 PH, Custom 450					Tool not recommended for this material group	
K	CAST IRONS (LOW & MEDIUM ALLOY) Gray, Malleable, Ductile					Tool not recommended for this material group	
N	ALUMINUM ALLOYS 2017, 2024, 356, 6061, 7075	≤ 150 Bhn or ≤ 7 HRc	Slot 	0.210	0.118	1600 (1280-1920)	RPM 29105 Fz 0.0026 Feed (ipm) 227.89
	ALUMINUM DIE CAST ALLOYS (HIGH SILICONE) A-390, A-392, B-390	≤ 125 Bhn or ≤ 77 HRb	Slot 	0.210	0.118	600 (480-720)	RPM 10914 Fz 0.0026 Feed (ipm) 85.46
	COPPER ALLOYS Alum Bronze, C110, Muntz Brass	≤ 140 Bhn or ≤ 3 HRc	Slot 	0.210	0.118	345 (276-414)	RPM 6276 Fz 0.0022 Feed (ipm) 40.79
	PLASTICS Polycarbonate, PVC, Polypropylene		Slot 	0.210	0.118	1600 (1280-1920)	RPM 29105 Fz 0.0044 Feed (ipm) 380.58
S	SUPER ALLOYS (NICKEL, COBALT, IRON BASE) Inconel 601, 617, 625, Incoloy, Monel 400					Tool not recommended for this material group	
	SUPER ALLOYS (NICKEL, COBALT, IRON BASE) Inconel 718, X-750, Incoloy, Waspaloy, Hastelloy, Rene					Tool not recommended for this material group	
	TITANIUM ALLOYS Pure Titanium, Ti6Al4V, Ti6Al2Sn4Zr2Mo, Ti4Al4Mo2Sn0.5Si					Tool not recommended for this material group	
	TITANIUM ALLOYS (DIFFICULT) Ti10Al2Fe3Al, Ti5Al5V5Mo3Cr, Ti7Al4Mo, Ti3Al8V6Cr4Zr4Mo, Ti6Al6V6Sn, Ti15V3 Cr3Sn3Al					Tool not recommended for this material group	
H	TOOL STEELS A2, D2, H13, L2, M2, P20, S7, T15, W2					Tool not recommended for this material group	

Bhn (Brinell) HRc (Rockwell C)
when recommended speed exceeds your capability, use maximum available and recalculate ipm
rpm = Vc x 3.82 / DC
ipm = Fz x 3 x rpm
reduce speed and feed for materials harder than listed
reduce feed and Ae when finish milling (.02 x DC maximum)
refer to the SGS Tool Wizard® for complete technical information (www.kyocera-sgstool.com)

Picatinny Rail Ferrous Dovetail Form Tool

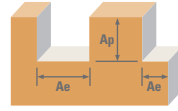

Picatinny Rail
Ferrous Dovetail Form Tool
5 Flute
Made to MIL-STD-1913

		Hardness			Vc (sfm)	DC • in		
			Ae x DC	Ap x DC		0.6050		
P	CARBON STEELS 1018, 1040, 1080, 1090, 10L50, 1140, 1212, 12L15, 1525, 1536	≤ 275 Bhn or ≤ 28 HRc	Profile 	≤ .50	APMX	450 (360-540)	RPM	2841
		Fz					0.0032	
		Feed (ipm)					46.03	
M	ALLOY STEELS 4140, 4150, 4320, 5120, 5150, 8630, 86L20, 50100	≤ 375 Bhn or ≤ 40 HRc	Profile 	≤ .50	APMX	260 (208-312)	RPM	1642
		Fz					0.0024	
		Feed (ipm)					19.68	
M	STAINLESS STEELS (FREE MACHINING) 303, 416, 420F, 430F, 440F	≤ 275 Bhn or ≤ 28 HRc	Profile 	≤ .50	APMX	400 (320-480)	RPM	2526
		Fz					0.0024	
		Feed (ipm)					30.28	
M	STAINLESS STEELS (DIFFICULT) 304, 304L, 316, 316L	≤ 275 Bhn or ≤ 28 HRc	Profile 	≤ .50	APMX	280 (224-336)	RPM	1768
		Fz					0.0019	
		Feed (ipm)					16.61	
M	STAINLESS STEELS (PH) 13-8 PH, 15-5 PH, 17-4 PH, Custom 450	≤ 325 Bhn or ≤ 35 HRc	Profile 	≤ .50	APMX	260 (208-312)	RPM	1642
		Fz					0.0019	
		Feed (ipm)					15.42	
K	CAST IRONS (LOW & MEDIUM ALLOY) Gray, Malleable, Ductile	≤ 220 Bhn or ≤ 19 HRc	Profile 	≤ .50	APMX	280 (224-336)	RPM	1768
		Fz					0.0029	
		Feed (ipm)					25.78	
N	ALUMINUM ALLOYS 2017, 2024, 356, 6061, 7075		Tool not recommended for this material group					
	ALUMINUM DIE CAST ALLOYS (HIGH SILICONE) A-390, A-392, B-390		Tool not recommended for this material group					
	COPPER ALLOYS Alum Bronze, C110, Muntz Brass		Tool not recommended for this material group					
S	PLASTICS Polycarbonate, PVC, Polypropylene		Tool not recommended for this material group					
	SUPER ALLOYS (NICKEL, COBALT, IRON BASE) Inconel 601, 617, 625, Incoloy, Monel 400	≤ 300 Bhn or ≤ 32 HRc	Profile 	≤ .50	APMX	75 (60-90)	RPM	474
		Fz					0.0018	
Feed (ipm)		4.22						
S	SUPER ALLOYS (NICKEL, COBALT, IRON BASE) Inconel 718, X-750, Incoloy, Waspaloy, Hastelloy, Rene	≤ 400 Bhn or ≤ 43 HRc	Profile 	≤ .50	APMX	60 (48-72)	RPM	379
		Fz					0.0013	
		Feed (ipm)					2.39	
S	TITANIUM ALLOYS Pure Titanium, Ti6Al4V, Ti6Al2Sn4Zr2Mo, Ti4Al4Mo2Sn0.5Si	≤ 350 Bhn or ≤ 38 HRc	Profile 	≤ .50	APMX	180 (144-216)	RPM	1137
		Fz					0.0021	
		Feed (ipm)					11.97	
S	TITANIUM ALLOYS (DIFFICULT) Ti10Al2Fe3Al, Ti5Al5V5Mo3Cr, Ti7Al4Mo, Ti3Al8V6Cr4Zr4Mo, Ti6Al6V6Sn, Ti15V3 Cr3Sn3Al	≤ 440 Bhn or ≤ 47 HRc	Profile 	≤ .50	APMX	70 (56-84)	RPM	442
		Fz					0.0021	
		Feed (ipm)					4.65	
H	TOOL STEELS A2, D2, H13, L2, M2, P20, S7, T15, W2	≤ 375 Bhn or ≤ 40 HRc	Profile 	≤ .50	APMX	145 (116-174)	RPM	916
		Fz					0.0019	
		Feed (ipm)					8.60	

Bhn (Brinell) HRc (Rockwell C)
 when recommended speed exceeds your capability, use maximum available and recalculate ipm
 $rpm = Vc \times 3.82 / DC$
 $ipm = Fz \times 5 \times rpm$
 reduce speed and feed for materials harder than listed
 reduce feed and Ae when finish milling (.02 x DC maximum)
 refer to the SGS Tool Wizard® for complete technical information (www.kyocera-sgstool.com)



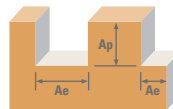

Picatinny Rail Non-Ferrous Dovetail Form Tool

Picatinny Rail
Non-Ferrous Dovetail
Form Tool
3 Flute
Made to MIL-STD-1913



DC • in

0.6050

	Hardness		Ae x DC	Ap x DC	Vc (sfm)		
P	CARBON STEELS 1018, 1040, 1080, 1090, 10L50, 1140, 1212, 12L15, 1525, 1536						Tool not recommended for this material group
	ALLOY STEELS 4140, 4150, 4320, 5120, 5150, 8630, 86L20, 50100						Tool not recommended for this material group
M	STAINLESS STEELS (FREE MACHINING) 303, 416, 420F, 430F, 440F						Tool not recommended for this material group
	STAINLESS STEELS (DIFFICULT) 304, 304L, 316, 316L						Tool not recommended for this material group
	STAINLESS STEELS (PH) 13-8 PH, 15-5 PH, 17-4 PH, Custom 450						Tool not recommended for this material group
K	CAST IRONS (LOW & MEDIUM ALLOY) Gray, Malleable, Ductile						Tool not recommended for this material group
N	ALUMINUM ALLOYS 2017, 2024, 356, 6061, 7075	≤ 150 Bhn or ≤ 7 HRc	Profile 	≤ .50	APMX	2000 (1600-2400)	RPM 12628 Fz 0.0056 Feed (ipm) 211.39
	ALUMINUM DIE CAST ALLOYS (HIGH SILICONE) A-390, A-392, B-390	≤ 125 Bhn or ≤ 77 HRb	Profile 	≤ .50	APMX	750 (600-900)	RPM 4736 Fz 0.0056 Feed (ipm) 79.27
	COPPER ALLOYS Alum Bronze, C110, Muntz Brass	≤ 140 Bhn or ≤ 3 HRc	Profile 	≤ .50	APMX	430 (344-516)	RPM 2715 Fz 0.0046 Feed (ipm) 37.72
	PLASTICS Polycarbonate, PVC, Polypropylene		Profile 	≤ .50	APMX	2000 (1600-2400)	RPM 12628 Fz 0.0093 Feed (ipm) 353.03
	SUPER ALLOYS (NICKEL, COBALT, IRON BASE) Inconel 601, 617, 625, Incoloy, Monel 400						Tool not recommended for this material group
S	SUPER ALLOYS (NICKEL, COBALT, IRON BASE) Inconel 718, X-750, Incoloy, Waspaloy, Hastelloy, Rene						Tool not recommended for this material group
	TITANIUM ALLOYS Pure Titanium, Ti6Al4V, Ti6Al2Sn4Zr2Mo, Ti4Al4Mo2Sn0.5Si						Tool not recommended for this material group
	TITANIUM ALLOYS (DIFFICULT) Ti10Al2Fe3Al, Ti5Al5V5Mo3Cr, Ti7Al4Mo, Ti3Al8V6Cr4Zr4Mo, Ti6Al6V6Sn, Ti15V3 Cr3Sn3Al						Tool not recommended for this material group
H	TOOL STEELS A2, D2, H13, L2, M2, P20, S7, T15, W2						Tool not recommended for this material group

Bhn (Brinell) HRc (Rockwell C)
when recommended speed exceeds your capability, use maximum available and recalculate ipm
rpm = Vc x 3.82 / DC
ipm = Fz x 3 x rpm
reduce speed and feed for materials harder than listed
reduce feed and Ae when finish milling (.02 x DC maximum)
refer to the SGS Tool Wizard® for complete technical information (www.kyocera-sgstool.com)