



SERVICE PARTS LIST

BULLETIN NO.
54-40-2570

SPECIFY CATALOG NO. AND SERIAL NO. WHEN ORDERING PARTS		REVISED BULLETIN	DATE
M12™ FUEL™ Hatchet™ Pruning Saw			Apr. 2022
CATALOG NO.	2527-20	STARTING SERIAL	L34A
		WIRING INSTRUCTION SEE PAGE 2	

FIG.	PART NO.	DESCRIPTION OF PART	NO. REQ.
4	34-40-9002	O-Ring	(1)
6	05-78-5316	M4 x14mm Pan Hd. Taptite T-20 Scr.	(12)
7	43-44-0022	Gasket	(1)
8	-----	Oil Tank	(1)
9	45-76-3005	Inlet Tube	(1)
10	-----	Cone Spring	(1)
11	05-78-0105	M4 x 10mm Pan Hd. Taptite T-20 Scr.	(1)
12	44-66-0053	Retaining Plate	(1)
13	45-76-2005	Outlet Tube	(1)
14	42-86-0012	Connector	(1)
15	34-40-4004	O-Ring	(1)
16	05-89-8005	Chain Tensioner Main Screw	(1)
17	05-89-2001	Chain Tensioning Post	(1)
18	05-81-9001	Chain Tensioner Adjustment Screw	(1)
19	05-85-0012	M8 x 28mm Hex Hd. Machine Screw	(1)

20	49-16-2732	6" Chain (Accessory)	(1)
21	49-62-2001	Scabbard	(1)
22	49-16-2733	6" Guide Bar (Accessory)	(1)
23	44-52-0018	Sealing Pad	(1)
24	05-55-5001	M8 Flange Nut	(1)
25	-----	Chain Cover	(1)

26	42-70-5268	E-Ring	(1)
27	45-88-7001	Chain Washer	(1)
28	45-44-0212	Sprocket	(1)
42	05-81-0015	M3 x 8.5mm Pan Hd. T-10 Mach. Scr.	(2)
43	-----	Motor Insulator Support - Right	(1)
52	-----	Motor Insulator Cover - Left	(1)
53	06-82-6351	M3 x 16mm Pan Hd. ST T-10 Screw	(15)
54	05-78-0870	M4 x 24mm Pan Hd. Taptite T-20 Scr.	(1)
55	43-54-0102	Knuckle Guard	(1)
56	-----	Handle Cover - Left	(1)
57	-----	Handle Support - Right	(1)
58	40-50-0209	Spring	(1)
59	-----	Lock-Off Button	(1)
60	45-96-1001	Wrench	(1)
62	05-81-1275	M4 x 19mm Pan Hd. Taptite T-20 Scr.	(1)
63	12-20-2533	Service Nameplate	(1)

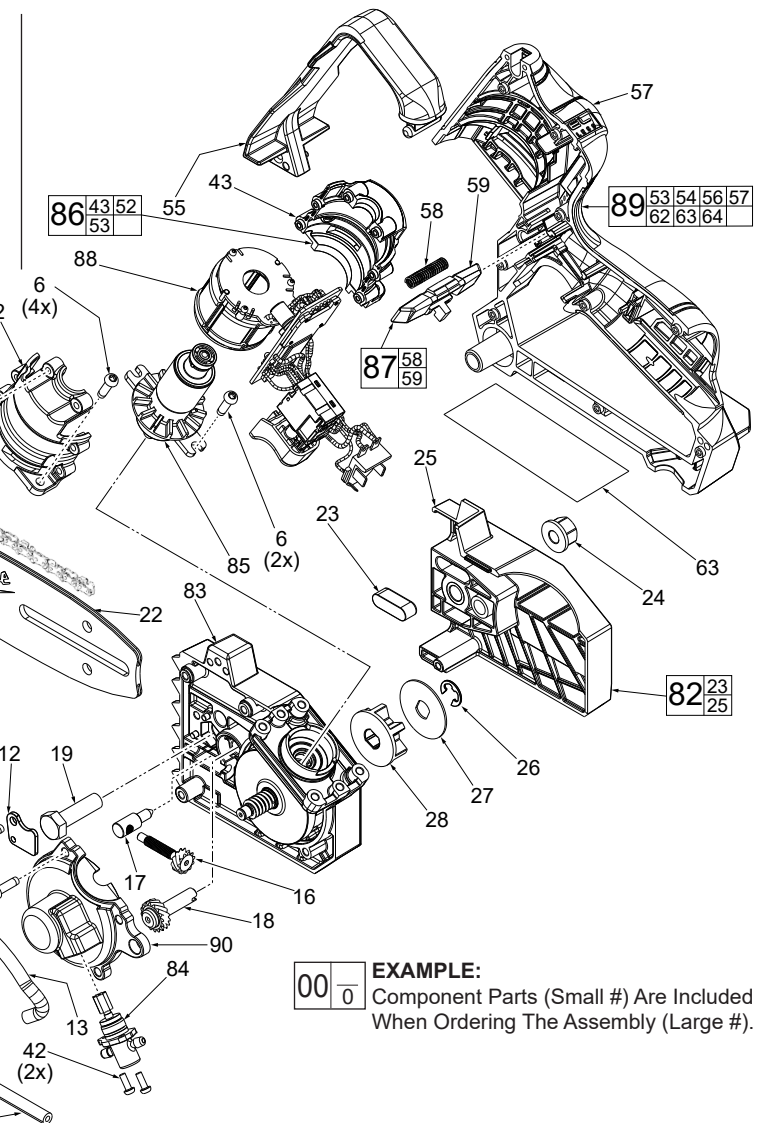

EXAMPLE:
Component Parts (Small #) Are Included
When Ordering The Assembly (Large #).

FIG.	PART NO.	DESCRIPTION OF PART	NO. REQ.
64	10-20-8033	Warning Label	(1)
80	42-52-3005	Oil Cap Assembly	(1)
81	45-66-3005	Oil Tank Assembly	(1)
82	43-72-0123	Chain Cover Kit	(1)
83	14-30-2527	Gearcase Assembly	(1)
84	42-54-0210	Oil Pump Assembly	(1)
85	16-01-1015	Rotor Assembly	(1)
86	23-16-0043	Motor Insulator Kit	(1)
87	42-42-2010	Lock-Off Button kit	(1)
88	14-20-1003	Electronics Assembly	(1)
89	14-34-0135	Handle Kit	(1)
90	42-92-0044	Gearcase Cover Assembly	(1)

SCREW TORQUE SPECIFICATIONS				
FIG.	PART NO.	WHERE USED	SEAT TORQUE	
			(KG/CM)	(IN/LBS)
6	05-78-5316	Gearcase Cover	25±3	22±3
11	05-78-0105	Gearcase	20±3	17±3
53	06-82-6351	Ground Plate	10±1	8±1

As an aid to reassembly, take notice of wire routings and position in wire guides and traps while dismantling tool.

Be sure that all components of electronics kit are seated firmly and squarely in housing recesses.

Avoid pinched wires, be sure that all wires and sleeves are pressed completely down in wire traps.

Prior to securing housing cover onto the housing support, be sure that there are no interferences.

Before installing the battery, check for proper functionality of shuttles and triggers.

Install battery and depress switch triggers to assure tool is operating properly.

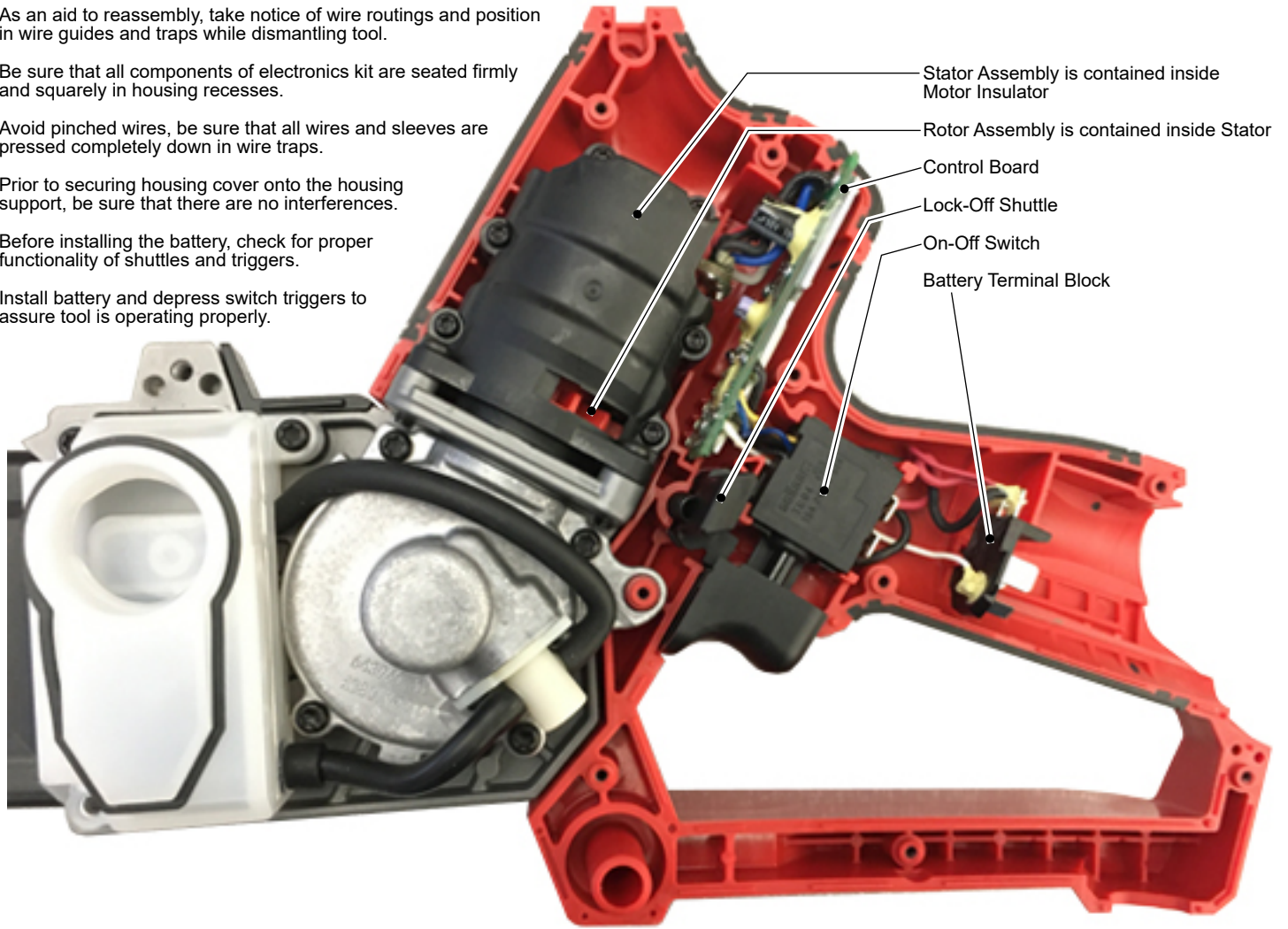

- Stator Assembly is contained inside Motor Insulator
- Rotor Assembly is contained inside Stator
- Control Board
- Lock-Off Shuttle
- On-Off Switch
- Battery Terminal Block

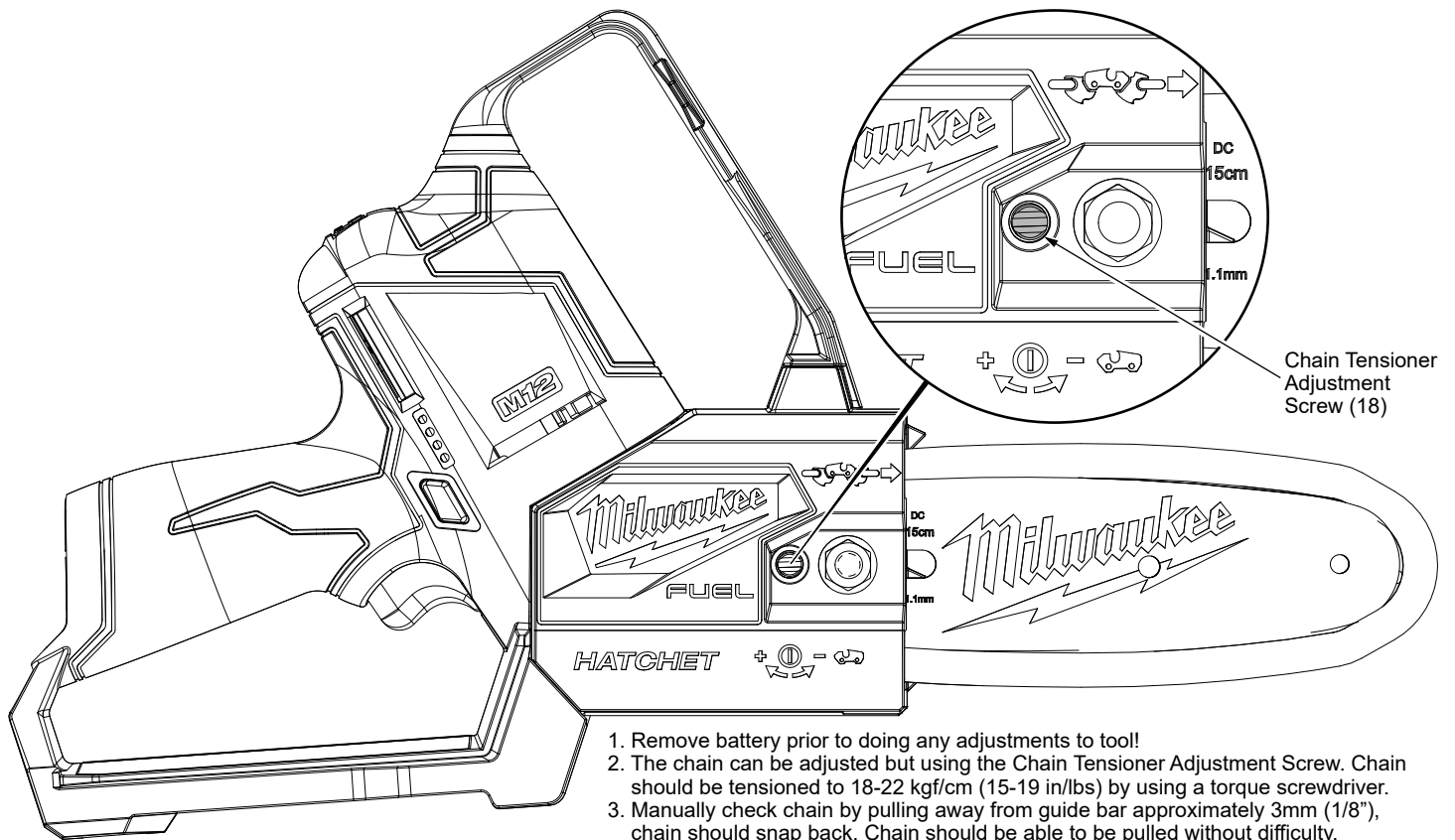

Chain Tensioner Adjustment Screw (18)

1. Remove battery prior to doing any adjustments to tool!
2. The chain can be adjusted but using the Chain Tensioner Adjustment Screw. Chain should be tensioned to 18-22 kgf/cm (15-19 in/lbs) by using a torque screwdriver.
3. Manually check chain by pulling away from guide bar approximately 3mm (1/8"), chain should snap back. Chain should be able to be pulled without difficulty.

Lubrication

