

NORTON

SAINT-GOBAIN

THE NORTON FULL LINE OF STOCK ABRASIVE PRODUCTS

EFFECTIVE | 2011

BONDED ABRASIVE PRODUCTS



COATED ABRASIVE PRODUCTS



NON-WOVEN PRODUCTS



SUPERABRASIVE PRODUCTS



NON-ABRASIVE PRODUCTS



THE **MUSCLE**
BEHIND THE MACHINE.™

www.nortonabrasives.com

TABLE OF CONTENTS

BONDED ABRASIVE PRODUCTS



Depressed Center Wheels	6
Small Diameter Cut-off Wheels	16
Right Angle Grinder Cut-off Wheels	18
Circular Saw Cut-off Wheels	22
High Speed Cut-off Wheels	23
Rail Cut-off Wheels	25, 26
Walk-Behind Cut-off Wheels	27
Chop Saw Cut-off Wheels	28
Stationary Cut-off Wheels	31
Foundry Cut-off Wheels	32
Toolroom Cut-off Wheels	34
Metallurgical Cut-off Wheels	36
Portable Snagging Wheels, Cones, Plugs	37
Floorstand and Swingframe Snagging Wheels	40
Bench and Pedestal Wheels	42
Mounted Points	45
Sharpening Stones	50
Rubbing Bricks	65
Dressing Sticks	283

NON-WOVEN PRODUCTS



Right Angle Grinder Discs	170
Brushes	175
Discs	176
Hand Pads, Rolls and Sponges	184
Surface Stripping Wheels	186
Unified Wheels	186
Convolute Wheels	190
Belts	194
Flap Wheels	196

DIAMOND TOOLS



Stationary Dressing Tools	236
Stationary Fliesen Tools	255

DIAMOND AND CBN WHEELS

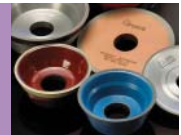

Norton Stock Wheels	258
Norton/Winter Toolroom Wheels	275
Norton B99 Express Wheels	276
CNC Wheels	279
Saw Grinding Wheels	280
Truing Devices	281
Truing and Dressing Guide	282
Dressing Sticks	283
Electroplated Products	286
Lapping Compound	298

NON-ABRASIVE PRODUCTS



Wire Brushes	198
Cloth Wipes	204
Polishing Pads	204
Masking Tape	205

COATED ABRASIVE PRODUCTS



Fiber Discs	66
Flap Discs	74
Paper Discs	83
Cloth PSA Discs	94
Flexible Diamond Discs	97
Quick-Change Discs	98
Paper Sheets and Rolls	111
Cloth Sheets and Rolls	118
Abrasive Sponges	120
Diamond Hand Pads	122
File Belts	124
Portable Belts	127
Narrow Belts	129
Wide Belts	135
NORaX Belts	138
FastTrack Belts	139
Flap Wheels and Sand-O-Flex Wheels	141
Specialties	153
Coated Abrasive Basics	299

PRECISION PRODUCTION



Toolroom Vitrified Wheels	206
Large Surface Grinding Wheels	223
Surface Grinding Segments	224
Cylindrical Wheels	226
Centerless and Feed Wheels	229
Creepfeed Blank Stock FastTrack Service	232
Norton Quantum Blank Stock FastTrack Service	233
55A Blank Stock FastTrack Service	234
Gear Wheel Blank Stock FastTrack Service	235

GENERAL INFORMATION



Catalog Navigation	4
Coated Abrasive Basics	299
Product Specification Key	300
Product Warranties	300
Safety Guidelines	301
Wheel Speed Conversion Table	307
Merchandising	308
Contact Information	309



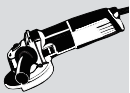

THE **MUSCLE**
BEHIND THE MACHINE.™

MACHINE INDEX

RIGHT ANGLE/VERTICAL SHAFT PORTABLE GRINDERS

	Depressed Center Grinding Wheels, Notchers,	8-15
	Saucers and Type 29 Wheels	
	Right Angle Grinder Reinforced Cut-off Wheels,	18-22
	Type O1 and Type 27	
	Coated Abrasive Fiber Discs	66-73
	Coated Abrasive Flap Discs	74-82
	Coated Abrasive Paper Discs	83-93
	Coated Abrasive Cloth PSA Discs	94
	Flexible Diamond PSA & Quick-Change Discs.	97
	Coated Abrasive Quick-Change Discs	98-110
	Non-Woven Depressed Center Wheels	172-174
	Non-Woven Discs	175-182
	Non-Woven Abrasive Brushes	175
	Wire Brushes	202

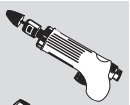
HORIZONTAL/STRAIGHT SHAFT PORTABLE GRINDERS

	Small Diameter Reinforced Cut-off	19-20
	Wheels (1-1/2"-6" wheels)	
	Cones and Plugs	37, 39
	Snagging Straight Wheels	37-38
	Mounted Points	45-49
	Coated Abrasive Large Diameter Flap	148
	Wheels (3-1/2"-5" wheels)	
	Non-Woven Unified Wheels	186-189
	Non-Woven Flap Wheels	197
	Wire Brushes	202

RIGHT ANGLE/VERTICAL SHAFT PORTABLE CUP GRINDERS

	Snagging Cup Wheels	37-38
	Wire Cup Brushes	200-201

PORTABLE CIRCULAR SAWS

	Circular Saw Reinforced Cut-off Wheels	22
---	--	----

HAND-HELD GAS OR ELECTRIC SAWS

	High Speed Reinforced Cut-off Wheels	23-25
	Rail Reinforced Cut-off Wheels	25-26

WALK-BEHIND SAWS

	Reinforced Cut-off Wheels	27
	Wire Brushes	202

CHOP SAW MACHINES

	Chop Saw Reinforced Cut-off Wheels	28-30
---	--	-------

STATIONARY CHOP STROKE MACHINES

	Large Diameter Reinforced Cut-off Wheels	31
	Foundry Cut-off Wheels	32-33

FLEXIBLE SHAFT MOTORS

	Non-Woven Surface Stripping Wheels.	187
	Non-Woven Unified Wheels	187-189



DRILLS

	Small Diameter Reinforced Cut-off Wheels	19-20
	(2" and 3" wheels with mandrel)	
	Coated Abrasive Small Diameter Flap Wheels	141-147
	Sand-O-Flex Wheels	152
	Non-Woven Surface Stripping & Unified Wheels	186-189

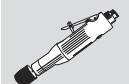
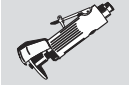
DIE AND PENCIL GRINDERS

	Mounted Points	45-49
	Coated Abrasive Small Diameter Flap Wheels	141-147, 151
	Coated Abrasive Specialties	153-165
	Non-Woven Flap Wheels (2"-4" wheels)	196
	Non-Woven Surface Stripping and	186-189
	Unified Wheels (1"-4" wheels)	
	Wire Brushes	202-203

BENCH AND PEDESTAL GRINDERS

	Vitrified Bench and Pedestal Wheels	42-44
	Coated Abrasive Large Diameter Flap Wheels	148-151
	Sand-O-Flex Wheels	152
	Non-Woven Discs (6"-12" discs)	183
	Non-Woven Unified Wheels (6" wheels)	188-189
	Non-Woven Convolute Wheels (6"-14" wheels)	190-193
	Non-Woven Flap Wheels (6"-8" wheels)	196-197
	Wire Brushes	201

ORBITAL SANDERS

	Coated Abrasive Paper Discs	83-93
	Coated Abrasive Small Diameter Cloth PSA Discs	95
	Flexible Diamond PSA Discs	97

STATIONARY DISC SANDERS

	Coated Abrasive Large Diameter Cloth	96
	PSA Discs (10"-24" discs)	

PORTABLE FILE BELT SANDERS

	Coated Abrasive File Belts	125-127
	Non-Woven File Belts	194

PORTABLE BELT SANDERS

	Coated Abrasive Portable Belts	128-129
	Non-Woven Portable Belts	194-195

IN-LINE DRUM SANDERS

	Coated Abrasive Portable Belts	128-129
	Non-Woven Portable Belts	194-195

BENCHSTAND GRINDERS

	Coated Abrasive Benchstand Belts.	130-133, 138-140
	Non-Woven Benchstand Belts	194-195

BACKSTAND BELT GRINDERS

	Coated Abrasive Backstand Belts.	130-131, 134, 138-140
	Non-Woven Backstand Belts	194-195

JITTERBUG SANDERS

	Coated Abrasive Sheets and Rolls	111-120
	Non-Woven Rolls	184-185

HAND FINISHING APPLICATIONS

	Sharpening Stones and Rubbing Bricks	50-65
	Coated Abrasive Paper Discs	93
	Coated Abrasive Sheets, Rolls and Sponges	111-122
	Flexible Diamond Hand Pads	123
	Non-Woven Hand Pads, Rolls and Sponges	184-185
	Wire Brushes	203
	Micro-fiber Cloths, Polishing Pads, Masking Tape	204-205

SANDING BOARDS

	Sanding Boards and Coated Abrasive File Strips.	115
---	---	-----

FLAP DISCS

MACHINES USED **C**



A CATEGORY DEFINITION

Flap discs are versatile grinding and finishing tools, consisting of three main components: a backing plate, adhesive, and abrasive cloth flaps. The rectangular flaps are overlapped and glued to the backing plate. Flap discs are designed for right angle grinder applications ranging from heavy stock removal to surface blending.

APPLICATIONS: Grinding, stock removal, edge chamfering/beveling, weld blending, deburring/deflashing, rust removal, blending, cleaning and finishing

SIZE RANGE: 4" - 5/8" hole
4-1/2" - 7": 5/8"-11 discard mount and 7/8" hole

B GRIT RANGE: 24 - 120

ABRASIVE GRAIN: Ceramic Alumina, Zirconia Alumina, Aluminum Oxide, Silicon Carbide

ABRASIVE FLAPS: Polyester or cotton

FLAP DISC SHAPE: Type 27 Flat and Type 29 Conical

ABRASIVE FLAP DENSITY: Standard or high

BACKING PLATE MATERIAL: Fiberglass, plastic or aluminum

FLAP DISC SHAPES



Type 27 Flat – The Best Choice for Finishing

- Used primarily on flat surfaces
- The best choice for blending and smooth finishing

GRIND AT FLATTER ANGLES:
0° - 15°



Type 29 Conical – The Best Choice for Aggressive Stock Removal

- Conical flap discs have angled flaps and may be used on both contoured and edge work
- The angle provides greater surface contact for stock removal on flat surfaces
- The best choice when speed and stock removal are primary considerations

GRIND AT STEEPER ANGLES:
15° - 25°

D

ABRASIVE FLAP DENSITIES



Standard Density

- Excellent for heavy-duty applications and rapid stock removal



High Density

- Ideal when working on uneven or curved surfaces, as well as finer grit blending

BACKING PLATE MATERIALS

All flap discs are a combination of abrasive flaps adhered to a rigid backing plate. It is the backing plate that provides stability during operation. There are three main materials used: fiberglass, plastic or aluminum. The fiberglass backing plate, along with the flap shape, helps to absorb vibration and is consumed during use with no smearing. Fiberglass is the most popular material because of its high strength and light weight. The plastic backing plate offers some additional conformability and is trimmable. The aluminum backing plate provides extra high strength and rigid support as needed. While not consumable during use, an aluminum plate can be recycled.



WHY CHOOSE FLAP DISCS? **E**

Flap discs replace both grinding wheels and fiber discs. The same flap disc can be used for applications:

Flap Discs vs. Grinding Wheels

- Faster stock removal
- Smother finish, no gouging
- Cooler cutting, less glazing
- Lightweight, easier to control
- Less vibration, less operator fatigue
- Reduced noise

Flap Discs vs. Fiber Discs

- 20X longer life
- Fewer discs
- More control
- No burn-through
- Easier to use
- Reduces dust
- Use in confined spaces

Easy to Follow Page Guide
Key Questions to Simplify Product Selection

Am I in the Right Section?

- A** Product category overview
- B** General attributes
- C** Correct machine use

How Do I Narrow my Choices?

- D** Product design variations
- E** Like product comparisons

FLAP DISCS

MACHINE USED **C**

MATERIAL-TO-PRODUCT RECOMMENDATION GUIDE

	BEST HIGHEST PRODUCTIVITY LOWEST TOTAL COST	BETTER EXCELLENT BLEND OF PERFORMANCE & PRICE	GOOD CONSISTENT PERFORMANCE LOW INITIAL PRICE
TYPE 29 FOR STOCK REMOVAL			
Stainless Steel / Titanium / Super Alloys	Norton SG Blaze R980P	NorZon BlueFire R884	Merit Metal
Mild Carbon Steel / Welds	Norton TwinFiber	NorZon BlueFire R884	Merit Metal
Ferrous Metals / Cast Iron	Norton TwinFiber	NorZon BlueFire R884	Merit Metal
Brass / Bronze / Aluminum	–	NorZon BlueFire R884	Merit Silicon Carbide
Paint / Glue / Adhesive	–	–	Merit Silicon Carbide
Concrete / Stone / Fiberglass	–	–	Merit Silicon Carbide
TYPE 27 FOR BLENDING AND FINISHING			
Stainless Steel / Titanium / Super Alloys	Norton SG Blaze R920	NorZon BlueFire R884	Merit Metal
Mild Carbon Steel / Welds	Norton TwinStar	NorZon BlueFire R884	Merit Metal
Ferrous Metals / Cast Iron	Norton TwinStar	NorZon BlueFire R884	Merit Metal
Brass / Bronze / Aluminum	–	NorZon BlueFire R884	Merit Metal

APPLICATION/GRIT RECOMMENDATION GUIDE **H**

COARSER (GRINDING)

GRIT: 24 36 40 50 60 80 100 120

HEAVY STOCK REMOVAL

EDGE CHAMFERING, BEVELING, WELD BLENDING

DEBURRING, DEFLASHING, RUST REMOVAL, BLENDING

CLEANING AND FINISHING

STANDARD DENSITY

FINER (FINISHING)

HIGH DENSITY

CROSS REFERENCE GUIDE **I**

	TOTAL PERFORMANCE		INITIAL PRICE	SPECIALTY
NORTON	BEST SG Blaze R980P/R920	TwinFiber / TwinStar	BETTER NorZon BlueFire R884	GOOD Metal / Zirconia Silicon Carbide
MERIT	947D	747D	5630, 5460	–
3M	–	–	–	–
DeWalt	–	–	–	Z/A
Camel	–	C3	Z-Stainless	Z3, A3
Flexovit	–	–	Zircotec Premium, Zircotec HP	–
Garryson	–	–	Zirc+, Zirconium	Aluminum Oxide
Gem-Tex	–	Ceramic	–	Zirconia, A/O
Hermes	–	–	–	–
Klingspor	–	–	SMT 630	SMT 618, 619, 624, 626, 627, 628, 640
Metabo	–	–	–	Z/A
Pearl	–	Stainless Max	Zirconia Premium, TuffMax	Z/A Silver Line, Premium A/O Classic, Silver Line
Piersl	–	Ceramic	Cool Zirconia, CO-COOL	Zirconia, Cool Aluminum Oxide, Aluminum Oxide
Salt	–	–	Z	Z/A, Z/A
SIA	–	–	–	Z/A
Standard	–	Ceramic Oxide	Zirconia Pro	Zirconia
Tyrolit	–	–	Z/A	A/O
Walter	–	–	Enduro Flex	–
Weiler	–	Saber Tooth Ceramic	–	Tiger Zirconium, A/O, Vortec

How Do I Match My End-User Needs?

- F** Application recommendations
- G** Best / Better / Good performance color coding
- H** Full application / grit guide

How Do I Match or Upgrade from a Competitive Product?

- I** Cross reference guide



FLAP DISCS

MACHINE USED **C**

MATERIAL-TO-PRODUCT RECOMMENDATION GUIDE

	BEST HIGHEST PRODUCTIVITY LOWEST TOTAL COST	BETTER EXCELLENT BLEND OF PERFORMANCE & PRICE	GOOD CONSISTENT PERFORMANCE LOW INITIAL PRICE
TYPE 29 FOR STOCK REMOVAL			
Stainless Steel / Titanium / Super Alloys	Norton SG Blaze R980P	NorZon BlueFire R884	Merit Metal
Mild Carbon Steel / Welds	Norton TwinFiber	NorZon BlueFire R884	Merit Metal
Ferrous Metals / Cast Iron	Norton TwinFiber	NorZon BlueFire R884	Merit Metal
Brass / Bronze / Aluminum	–	NorZon BlueFire R884	Merit Silicon Carbide
Paint / Glue / Adhesive	–	–	Merit Silicon Carbide
Concrete / Stone / Fiberglass	–	–	Merit Silicon Carbide
TYPE 27 FOR BLENDING AND FINISHING			
Stainless Steel / Titanium / Super Alloys	Norton SG Blaze R920	NorZon BlueFire R884	Merit Metal
Mild Carbon Steel / Welds	Norton TwinStar	NorZon BlueFire R884	Merit Metal
Ferrous Metals / Cast Iron	Norton TwinStar	NorZon BlueFire R884	Merit Metal
Brass / Bronze / Aluminum	–	NorZon BlueFire R884	Merit Metal

APPLICATION/GRIT RECOMMENDATION GUIDE **H**

COARSER (GRINDING)

GRIT: 24 36 40 50 60 80 100 120

HEAVY STOCK REMOVAL

EDGE CHAMFERING, BEVELING, WELD BLENDING

DEBURRING, DEFLASHING, RUST REMOVAL, BLENDING

CLEANING AND FINISHING

STANDARD DENSITY

FINER (FINISHING)

HIGH DENSITY

CROSS REFERENCE GUIDE **I**

	TOTAL PERFORMANCE		INITIAL PRICE	SPECIALTY
NORTON	BEST SG Blaze R980P/R920	TwinFiber / TwinStar	BETTER NorZon BlueFire R884	GOOD Metal / Zirconia Silicon Carbide
MERIT	947D	747D	5630, 5460	–
3M	–	–	–	–
DeWalt	–	–	–	Z/A
Camel	–	C3	Z-Stainless	Z3, A3
Flexovit	–	–	Zircotec Premium, Zircotec HP	–
Garryson	–	–	Zirc+, Zirconium	Aluminum Oxide
Gem-Tex	–	Ceramic	–	Zirconia, A/O
Hermes	–	–	–	–
Klingspor	–	–	SMT 630	SMT 618, 619, 624, 626, 627, 628, 640
Metabo	–	–	–	Z/A
Pearl	–	Stainless Max	Zirconia Premium, TuffMax	Z/A Silver Line, Premium A/O Classic, Silver Line
Piersl	–	Ceramic	Cool Zirconia, CO-COOL	Zirconia, Cool Aluminum Oxide, Aluminum Oxide
Salt	–	–	Z	Z/A, Z/A
SIA	–	–	–	Z/A
Standard	–	Ceramic Oxide	Zirconia Pro	Zirconia
Tyrolit	–	–	Z/A	A/O
Walter	–	–	Enduro Flex	–
Weiler	–	Saber Tooth Ceramic	–	Tiger Zirconium, A/O, Vortec





NORZON PLUS

Charger™

Gemini



CATEGORY DEFINITION

Depressed center wheels may also be referred to as raised hub wheels or by their shape designation of "Type", with Type 27 being the most popular. The depressed center design allows the flange/lock nut to recess within the wheel so that it can be used for various grinding and cutting applications. Depressed center wheels are designed to handle the most severe right angle grinding applications from heavy stock removal to rough blending. More recently, depressed center wheels have been designed to increase the utility of the tool for cut-off applications. While large right angle grinders (7" & 9") have been around for many years, small or mini grinders that handle 4", 4-1/2" and 5" wheels have made this machine, and wheel category, the most popular in power tools.

- APPLICATIONS: Grinding, stock removal, edge chamfering, beveling, weld blending, and cutting-off
- SIZE RANGE: 2" – 9"
- THICKNESS RANGE: .040 (1/32) – .250 (1/4")
- GRIT RANGE: 24 – 46 grits for stock removal; 60, 80, 120 grits for blending and finishing
- ABRASIVE GRAIN: Ceramic Alumina, Zirconia Alumina, Aluminum Oxide, Silicon Carbide
- MOUNTING OPTIONS: Plain hole (5/8" and 7/8") and discard mount (3/8-24" and 5/8-11")
- SHAPE: Type 27, Type 28, Type 29

TYPE-TO-APPLICATION RECOMMENDATION GUIDE

WHEEL TYPE/THICKNESS

APPLICATIONS

TYPE 27

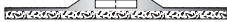

Type 27 wheels are essentially straight wheels that have a "depressed center/raised hub". Different types of fiberglass reinforcement mesh give the product stability for use on the periphery, on the face, or a combination of the two.

			
	90° ANGLE	30° ANGLE	
.040", .045", .060", and .090" Type 27 RightCut	■		
.090" Type 27 RightCut	■		
.125" Type 27 RightCut	■		
1/8" Type 27	■	■	
5/32" Type 27	■	■	
1/8" Type 27 Flexible	■		
1/8" Type 27 Foundry Notchers	■	■	
1/4" Type 27	■	■	
1/4" Type 27 Foundry Snaggers	■	■	
1/4" Type 27 Heavy-Duty Foundry	■	■	

TYPE 28

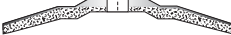

Type 28 wheels are constructed with a downward angle built into the grinding section to facilitate a flatter grinding angle. These wheels can only be used on the face and never on the periphery for cutting-off.

			
			15° ANGLE
1/4" Type 28 Saucers			■

TYPE 29



Type 29 wheels are constructed with an upward angle built into the grinding section to provide full face contact for light stock removal and blending operations. These wheels can only be used on the face and never on the periphery for cutting-off.

			
			15° ANGLE
1/8" Type 29 Flexible, AVOS			■



MATERIAL/APPLICATION-TO-PRODUCT RECOMMENDATION GUIDE

	BEST HIGHEST PRODUCTIVITY LOWEST TOTAL COST	BETTER EXCELLENT BLEND OF PERFORMANCE & PRICE	GOOD CONSISTENT PERFORMANCE LOW INITIAL PRICE
CUTTING			
Mild Carbon / High Tensile Steel	NorZon Plus	Charger Plus	Metal
Stainless Steel / Alloys	NorZon Plus	Charger Plus	Gemini
Contaminate Free		Charger Plus INOX	Gemini INOX
Cast Iron	NorZon Plus	Charger Plus	Gemini
Gray Iron		Charger Foundry	
Aluminum / Bronze / Brass			Gemini Aluminum
Asphalt / Brick / Concrete			Masonry
Fiberglass / Plastic			Masonry
NOTCHING			
Mild Carbon / High Tensile Steel	NorZon Plus	Charger Plus	Metal
Stainless Steel / Alloys	NorZon Plus	Charger Plus	Gemini
Contaminate Free		Charger Plus INOX	Gemini INOX
Cast Iron	NorZon Plus	Charger Plus	Gemini
GRINDING			
Mild Carbon / High Tensile Steel	NorZon Plus	Charger Plus	Metal
Stainless Steel / Alloys	NorZon Plus	Charger Plus	Gemini
Contaminate Free		Charger Plus INOX	Gemini INOX
Cast Iron	NorZon Plus	Charger Plus	Gemini
Gray Iron	NorZon Plus Foundry	Charger Foundry	Gemini
Aluminum / Bronze / Brass			Gemini Aluminum
Asphalt / Brick / Concrete			Masonry
BLENDING			
Mild Carbon / High Tensile Steel		Charger AVOS Flexible	Gemini Flexible
Stainless Steel / Alloys		Charger AVOS Flexible	Gemini Flexible
Aluminum / Bronze / Brass		Charger AVOS Flexible	Gemini Flexible
Fiberglass / Plastic		Charger AVOS Flexible	Gemini Flexible

TYPICAL STEEL, STAINLESS STEEL, CAST IRON PRODUCTS: ANGLE IRON, BAR STOCK, DUCTILE PIPE, CHANNEL IRON, DECKING, REBAR, I-BEAMS, RAIL STEEL, STUDS, TUBING, AND WELDS

HOW TO PICK THE RIGHT BOND TYPE

Standard	<i>Unmarked</i>	Where an excellent blend of cut rate and life is needed
Fast Cut	FC	Where fast stock removal is needed, or the application only allows for low-pressure or under-horsepowered grinders
Long Life	LL	Where durability is needed due to severe application, and when horsepower of the grinder allows for heavy pressure
Contaminate Free	INOX	Contain <0.1% iron, sulfur or chlorine for rust-free and corrosion-free results. Will not contaminate stainless steel

HOW TO PICK THE RIGHT MOUNT

Most wheel sizes come with a plain hole or a discard mount option. While the plain hole has a small, initial cost advantage, the discard mount can provide a labor cost advantage with the quicker wheel change.

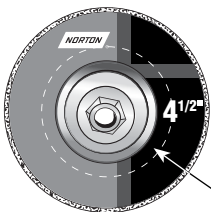

Mini-Mount Hub

Our unique, patented mini-mount hub used on 4-1/2" and 5" depressed center wheels provides up to 30% more wheel life because the hub covers just a small surface area, providing maximum grinding area exposure and usage.

STANDARD THROW-AWAY HUB SIZE

WHY CHOOSE DEPRESSED CENTER WHEELS?

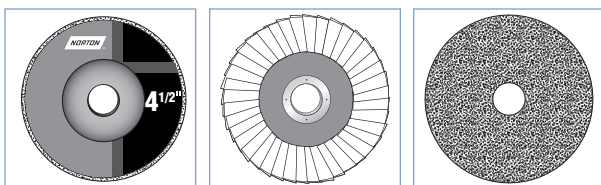

Depressed Center Wheels vs. Flap Discs or Fiber Discs

- Up to 5X life over flap discs, less downtime
- Up to 100X life over fiber discs, less downtime
- Rigidity for severe operations and high power grinders
- 1/8" wheels can be used for cutting and grinding
- Can be used to grind inside corners at outer edge of wheel



CROSS REFERENCE GUIDES

TYPE 27 RIGHTCUT – .040" - .125"

	TOTAL PERFORMANCE			INITIAL PRICE			SPECIALTY
	BEST NorZon Plus	BETTER Charger Plus	GOOD Gemini INOX	Gemini Long Life	Gemini	Metal	GOOD Gemini Aluminum
Brilliant	—	—	—	Brill-Blade Heavy Duty	Brill-Blade Extra FC	Hornet	—
Bullard	—	ZA60T	—	TA46T, TA60T TA60U	SGA60U	A46T, A60T Comp.	AL46N
Camel	—	ZA Quickie Cut	A60-T-BF, WA60R Quickie Cut	Super Quickie Cut	A36-S-BF	—	A46 Quickie Cut
Flexovit	—	—	—	Razorblade A60SST	Razorblade A24T, 30V, 36T	—	—
Pearl	—	Redline Max Slimcut	—	Slimcut	—	Slimcut Pro-V, Silverline	—
Pferd	—	SGP-ZA-Q- INOX	SG-A-R-INOX, SGP-A-S-INOX	SG-A-S, SGP-A-T	—	PSF-A-P	S-G-N-ALU
Sait	Saitech	Z-tech	XA46R	A60S	SAIT.M.X	—	A46N
SpedeCut	—	—	—	—	—	A46, 60 TBXX	—
Walter	—	—	A-60SS-ZIP	A-60-ZIP	A-30-ZIP	—	A-60-ZIP-ALU

TYPE 27 AND 28 – 1/8" AND 1/4"

	TOTAL PERFORMANCE					INITIAL PRICE				SPECIALTY	
	BEST NorZon Plus	NorZon Plus Long Life	BETTER Charger Plus INOX	Charger Plus	Charger Plus Foundry	GOOD Gemini	Gemini Fast Cut	Gemini INOX	Metal	GOOD Gemini Aluminum	Masonry
Brilliant	—	—	Brill-Max Z24R	—	—	Brill-Tex A24UHPXL, A30T	Brill-Tex A24R Super-G	Brill-Tex A30P	Hornet Metal	Brill-Tex A30ALU	Brill-Tex C30P, Hornet Concrete
Bullard	TA24S	—	ZA24R	ZA24R Competitor	—	A24R	A24N	A46Q	A24R Competitor	AL36N	C24R
Camel	—	—	ZA24T	—	—	A24R	Ultra A24-N-BF, A24T Super Quickie Cut	WA24S	A24N, R & T Fast Cut	A30N, Fast Cut	C24R
Flexovit	Flexon ZA20Q	Flexon ZA24P ZA30T	—	Metalhog AXT24S	Flexon ZA16U	High Performance A24/30T	High Performance A30S, Specialist A30Q & R	Free Grind A30Q	—	Specialist A24ALU	High Performance C24/30P
Metabo	—	—	ZA24T	—	—	A24R & T	A24N	A36Q	—	A36M	C24N
Pearl	—	—	Z24T	—	—	Premium Metal A24S, Redline Max A/WA24S	Premium Metal A24R, Redline Max A/WA24R	WA24R, SRT24	Silver Line A24R & S	D.A. Series AL24M	Silver Line C24S
Pferd	—	—	ZA R SGP, Z-SG	ZA S GP, ZA T SGP	—	A-PS, A-SG	—	A-SG INOX, A-PS INOX	—	A-SG ALU	S-SG, Masonry
Sait	Saitech Attacker, Pipeline	Saitech Ultimate Performance	Z24R Z-tech	—	CA24R - Foundry	A24R, A24 Turbo	A24N	XA24Q	—	A46N - Aluminum	C24N
Tyrolit	—	—	ZA24N-BFX	ZA24P-BFX	ZZA24R-BFX	A30S & Q-BFX	A30R-BFX	A30-BF INOX	A30-BF	A36N-BFX WA46-BF	C30-BF
Walter	—	—	Double-X, Allsteel	Allsteel XX	—	HP	—	Stainless	—	Aluminum	Concrete

TYPE 27 – FLEXIBLE 1/8"

	TOTAL PERFORMANCE		INITIAL PRICE
	BETTER Charger Flex	GOOD Gemini Flex	
Brilliant	—	Brill-Flex	
Bullard	—	Flexlite AC	
Camel	—	FGF, Special Wheel	
Flexovit	—	Flexcel	
Metabo	—	Z-Plus	
Pearl	—	Flexible AC	
Pferd	SG-Flex	—	
Sait	—	Challenger II	
Walter	—	Flexcut	



FEATURED PRODUCTS



NORZON PLUS

BEST/HIGHEST PRODUCTIVITY FOR STEEL, STAINLESS STEEL AND ALL OTHER FERROUS METALS

FEATURES

- Combination of patented Norton SG (ceramic alumina) and NorZon (zirconia alumina) with an advanced bond system
- Foundry Snagger

BENEFITS

- 50 to 200% better overall performance vs. competitive zirconia and ceramic wheels
- Lowest total grinding cost; highest productivity
- Up to 10X the performance of aluminum oxide wheels
- 50% or better cut rate than competitive zirconia wheels
- Easy on the operator and equipment
- Designed to withstand the most aggressive foundry application



CHARGER PLUS

BETTER CHOICE FOR STEEL, STAINLESS STEEL AND ALL OTHER FERROUS METALS

FEATURES

- High-ratio zirconia alumina blend with aluminum oxide
- Charger Contaminate Free **INOX**
- Charger Foundry
- AVOS Charger Flexible (with aluminum oxide grain)

BENEFITS

- 3 times the life of aluminum oxide wheels
- Ideal for stainless steel and carbon steel applications, efficiently grinds a variety of materials from alloys to gray iron
- Excellent performance to price ratio lowers total grinding costs
- Contain <0.1% iron, sulfur or chlorine for rust-free and corrosion-free result; will not contaminate stainless steel
- Zirconia alumina/silicon carbide abrasive and reinforcement structure designed for aggressive foundry applications
- Patented shape design provides complete vision of the grinding zone, for more efficient grinding, less gouging, and heat-reducing interrupted cuts
- Uniquely-patterned face creates cooler grinding and minimal gouging



GEMINI

GOOD CHOICE FOR STEEL AND FERROUS METALS AS WELL AS SPECIALTY APPLICATIONS IN ALUMINUM AND FOUNDRIES

FEATURES

- Quality aluminum oxide
- Gemini Contaminate Free **INOX**
- Gemini Aluminum

BENEFITS

- Consistent performance at a competitive price
- Contain <0.1% iron, sulfur or chlorine for rust-free and corrosion-free results; will not contaminate stainless steel
- Grind aluminum and soft metals without loading
- Contain no wax or rubber fillers



NORTON METAL/MASONRY

GOOD CHOICE FOR STEEL/FERROUS METAL AND MASONRY APPLICATIONS WITH LOW INITIAL PRICE

FEATURES

- Competitive initial price point
- Metal – aluminum oxide
- Masonry – sharp silicon carbide

BENEFITS

- Best starting specification for end user unable to measure performance
- Engineered for all steel/ferrous materials
- Engineered for all masonry materials such as concrete, brick and asphalt

Norton Fine, Hard Back Depressed Center Wheels Boost Productivity and Wheel Life

Versus Competitors' Monolithic Design (2 coarse layers)

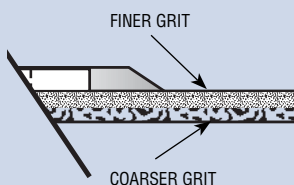

Our fine, hard back (a finer-grit mixture in the top half of the grinding wheel) limits premature shedding or “spalling” and allows for a smoother grinding action from the periphery to the hub.

- At the proper grinding angle, a sharp bevel is produced at the wheel periphery
- As the wheel wears, this thin edge become susceptible to stress
- A coarse grit back is much more likely to break away prematurely resulting in unnecessary wheel loss and quite possibly an injury to operator and others



AVAILABILITY



TIER:	BEST	BETTER	GOOD	GOOD
TRADENAME:	NORZON PLUS	CHARGER PLUS	GEMINI	NORTON METAL
SHAPE:	Type 27	Type 27	Type 27	Type 27
ABRASIVE:	Ceramic Alumina/ Zirconia Alumina	Zirconia Alumina/ Aluminum Oxide	Aluminum Oxide	Aluminum Oxide
MATERIAL:	STAINLESS STEEL / METAL	STAINLESS STEEL / METAL	STAINLESS STEEL / METAL	STAINLESS STEEL / METAL

SIZE (D X T X H)	MAX. RPM	STD. PKG.	PART NO.	PART NO.	PART NO.	PART NO.
.040, .045, .060, .090, .125 – RIGHTCUT CUT-OFF – TYPE 27						
4 x .045 x 5/8	15,280	20			66252833840	07660705249
4 x .125 x 3/8	15,280	20	66243529883			
4-1/2 x .040 x 5/8-11	13,580	20		66252837013		
4-1/2 x .045 x 5/8-11	13,580	20	66252830748	66252832009	66252819549	
4-1/2 x .045 x 7/8	13,580	20	66252830742	66252830125	66252819548	INOX 66252836497
4-1/2 x .090 x 5/8-11	13,580	20			66252823102	
4-1/2 x .090 x 7/8	13,580	20			66252835320	
		20			66252823103	INOX
4-1/2 x .125 x 5/8-11	13,580	20	66252815010		66252813301	
4-1/2 x .125 x 7/8	13,580	20	66252830443		66252801860	
5 x .040 x 5/8-11	12,225	20		66252837014		
5 x .045 x 5/8-11	12,225	20			66252830586	
5 x .045 x 7/8	12,225	20	66252830744	66252830126	66252819550	
5 x .090 x 7/8	12,225	20			66252823106	INOX
		20			66252836984	LL
5 x .125 x 7/8	12,225	20			66252801862	
6 x .045 x 5/8-11	10,185	20			66252830587	
6 x .045 x 7/8	10,185	20	66252830745	66252830127	66252819551	
6 x .090 x 7/8	10,185	20			66252832487	INOX
7 x .060 x 7/8	8,600	20			66252912626	
		10				07660705251
7 x .090 x 7/8	8,600	20			66252914638	INOX
7 x .125 x 5/8-11	8,600	10	66252912625			
7 x .125 x 7/8	8,600	20	66252912624		66252900619	
9 x .060 x 5/8-11	6,600	10			66253019115	

RIGHTCUT WHEELS ARE TO BE USED FOR CUTTING ONLY.

1/8" – PIPE NOTCHING – TYPE 27						
7 x 1/8 x 5/8-11	8,600	10	66252939184			
9 x 1/8 x 5/8-11	6,600	10	66253049066			

PIPE NOTCHERS ARE TO BE USED FOR CUTTING/NOTCHING ONLY.

1/8", 5/32" – CUTTING / NOTCHING / LIGHT GRINDING – TYPE 27						
3 x 1/8 x 3/8	18,000	20	66243528697			
4 x 1/8 x 3/8	15,280	20	66243529884	66243529893	66243529686	
4 x 1/8 x 5/8	15,280	20	66243529885	66243529851	66243530619	
		10				07660775930
4-1/2 x 1/8 x 5/8-11	13,580	20	66252830445	66252829853	66252830435	07660702677
		20		66243578249	INOX	
4-1/2 x 1/8 x 7/8	13,580	20	66252830444	66252829854	66252830609	66252836798
		20		66243578248	INOX	
5 x 1/8 x 5/8-11	12,225	20	66252832398	66252829857		
		20		66243578253	INOX	
		5				07660775915
5 x 1/8 x 7/8	12,225	20	66252830789	66252829858	66252830614	
		20		66243578252	INOX	
		10				07660775916
5 x 5/32 x 7/8	13,580	20			66252835579	
6 x 1/8 x 5/8-11	10,185	10		66243578257	INOX	66252833965
6 x 1/8 x 7/8	10,185	20		66252809367		66252801864
		20		66243578256	INOX	
6 x 5/32 x 7/8	10,185	20			66252835580	

CONTINUED

DEPRESSED CENTER DESCRIPTION CODES

INOX = CONTAMINANT FREE	FC = FAST CUT	LL = LONG LIFE	HD = HEAVY DUTY	BLANK = ALL PURPOSE
■ = STAINLESS	■ = STEEL / METAL	■ = FOUNDRY	■ = MASONRY	■ = ALUMINUM



AVAILABILITY



TIER:	BEST	BETTER	GOOD	GOOD
TRADENAME:	NORZON PLUS	CHARGER PLUS	GEMINI	NORTON METAL
SHAPE:	Type 27 and Type 28	Type 27 and Type 28	Type 27 and Type 28	Type 27
ABRASIVE:	Ceramic Alumina/ Zirconia Alumina	Zirconia Alumina/ Aluminum Oxide	Aluminum Oxide	Aluminum Oxide
MATERIAL:	STAINLESS STEEL / METAL	STAINLESS STEEL / METAL	STAINLESS STEEL / METAL	STAINLESS STEEL / METAL

SIZE (D X T X H)	MAX. RPM	STD. PKG.	PART NO.	PART NO.	PART NO.	PART NO.
1/8", 5/32" – CUTTING / NOTCHING / LIGHT GRINDING – TYPE 27						
7 x 1/8 x 5/8-11	8,600	10	66252938855	66252929862	66252939259	07660702678
		10		66243578241 INOX		
7 x 1/8 x 7/8	8,600	20	66252938854	66252929863	66252939207	
		20		66243578240 INOX		07660775956
		5				
7 x 5/32 x 7/8	8,600	20			66252835581	
9 x 1/8 x 5/8-11	6,600	10	66253048897	66253029866		
		10		66243578245 INOX		07660775939
		5				
9 x 1/8 x 7/8	6,600	20	66253048896	66253029867	66253048994	
		20		66243578244 INOX		
1/4" – GRINDING – TYPE 27						
3 x 1/4 x 3/8	18,000	20	66243528809		66243528855	
4 x 1/4 x 3/8	15,280	20	66243529886	66243529899	66243529748	
4 x 1/4 x 5/8	15,280	20	66243529887	66243529852	66243519884 FC	66252836797
		20			66243530620	
		20			66252830575	
4-1/2 x 3/16 x 7/8	13,580	20	66252830446		66252817084 FC	66252819559
4-1/2 x 1/4 x 5/8-11	13,580	20	66252828804	66252829855	66252830432	
		20	66252835576 LL	66243578251 INOX	66252819568 INOX	
		20			66252830612 FC	66252836796
4-1/2 x 1/4 x 7/8	13,580	20	66252828803	66252829856	66252830611	
		20		66243578250 INOX	66252819567	
		20			66252837010	
5 x 1/4 x 5/8-11	12,225	20	66252828806	66252829859		
		20	66252835577 LL	66243578255 INOX		07660775913
		5				
5 x 1/4 x 7/8	12,225	20	66252828805	66252829861	66252830617 FC	
		20		66243578254 INOX	66252830615	
		20			66252819570 INOX	07660775918
		5				
6 x 1/4 x 5/8-11	10,185	10		66252832391	66252832390	
		10		66243578259 INOX		
6 x 1/4 x 7/8	10,185	20	66252809376	66252809372	66252801865	
		20		66243578258 INOX		
7 x 1/4 x 5/8-11	8,600	10	66252917881	66252929864	66252940147 FC	66252912633
		10	66252835578 LL	66243578243 INOX	66252940148	
7 x 1/4 x 7/8	8,600	20	66252917880	66252929865	66252940099 FC	
		20		66243578242 INOX	66252940098	07660775936
		5				
9 x 1/4 x 5/8-11	6,600	10	66253021634	66253029868	66253049105 FC	07660775938
		10	66252830728 LL	66243578247 INOX	66253049104	
		5				07660775938
9 x 1/4 x 7/8	6,600	20	66253021633	66253029869	66253049077 FC	
		20		66243578246 INOX		07660775935
		5				
1/4" – GRINDING – TYPE 28 SAUCER						
7 x 1/4 x 5/8-11	8,600	10	66252905369	66252905367	66252940149	
7 x 1/4 x 7/8	8,600	20	66252905368		66252940095	
9 x 1/4 x 5/8-11	6,600	10	66253006335	66253006334	66253049106	
9 x 1/4 x 7/8	6,600	20			66253049081	

DEPRESSED CENTER DESCRIPTION CODES

INOX = CONTAMINANT FREE	FC = FAST CUT	LL = LONG LIFE	HD = HEAVY DUTY	BLANK = ALL PURPOSE
■ = STAINLESS	■ = STEEL / METAL	■ = FOUNDRY	■ = MASONRY	■ = ALUMINUM



AVAILABILITY



TIER:	BEST	BETTER
TRADENAME:	NORZON PLUS	CHARGER PLUS
SHAPE:	Type 27	Type 27
ABRASIVE:	Ceramic Alumina/ Zirconia Alumina	Zirconia Alumina/ Silicon Carbide
MATERIAL:	FOUNDRY	FOUNDRY

SIZE (D X T X H)	MAX. RPM	STD. PKG.	PART NO.	PART NO.
1/8", 1/4" – GRINDING / CUTTING – TYPE 27				
4 x 1/4 x 3/8	15,280	20		66243531504
4 x 1/4 x 5/8	15,280	20		66243531502
4-1/2 x 1/8 x 5/8-11	13,580	20		66252824508
4-1/2 x 1/8 x 7/8	13,580	20		66252824504
4-1/2 x 1/4 x 5/8-11	13,580	20		66252824509
4-1/2 x 1/4 x 7/8	13,580	20		66252824505
7 x 1/8 x 5/8-11	8,600	10		66252915529
7 x 1/4 x 5/8-11	8,600	10		66252915528
7 x 1/4 x 7/8	8,600	20		66252915527
9 x 1/8 x 5/8-11	6,600	10		66253018579
9 x 1/8 x 7/8	6,600	20		66253018574
		20		66253018940
9 x 1/4 x 5/8-11	6,600	10	66253007014	66253018580
		10		66253020902 HD
9 x 1/4 x 7/8	6,600	20	66253007013	66253018575
		20	66252832897 HD	66253020901 HD



TIER:	GOOD
TRADENAME:	GEMINI
SHAPE:	Type 27
ABRASIVE:	Aluminum Oxide
MATERIAL:	ALUMINUM

SIZE (D X T X H)	MAX. RPM	STD. PKG.	PART NO.
1/8", 1/4" – GRINDING / CUTTING / BLENDING – TYPE 27			
4 x 1/4 x 5/8	15,280	20	66243529741
4-1/2 x 1/8 x 5/8-11	13,580	20	66252819555
4-1/2 x 1/8 x 7/8	13,580	20	66252819554
4-1/2 x 1/4 x 5/8-11	13,580	20	66252830433
4-1/2 x 1/4 x 7/8	13,580	20	66252830627
5 x 1/4 x 7/8	12,225	20	66252823273
7 x 1/4 x 5/8-11	8,600	10	66252940514
		10	66252940515
7 x 1/4 x 7/8	8,600	20	66252940516
9 x 1/4 x 5/8-11	6,600	10	66253049045



TIER:	GOOD
TRADENAME:	NORTON MASONRY
SHAPE:	Type 27
ABRASIVE:	Silicon Carbide
MATERIAL:	MASONRY

SIZE (D X T X H)	MAX. RPM	STD. PKG.	PART NO.
1/8", 1/4" – GRINDING / CUTTING – TYPE 27			
4 x 1/8 x 5/8	15,280	10	07660775914
4 x 1/4 x 5/8	15,280	10	07660775912
4-1/2 x 1/8 x 5/8-11	13,580	10	07660775909
4-1/2 x 1/4 x 5/8-11	13,580	5	07660775993
4-1/2 x 1/4 x 7/8	13,580	10	07660775944
5 x 1/8 x 7/8	12,225	10	07660775945
5 x 1/4 x 7/8	12,225	5	07660775902
7 x 1/4 x 5/8-11	8,600	5	07660775942
7 x 1/4 x 7/8	8,600	5	07660775946
9 x 1/4 x 5/8-11	6,600	5	07660775937

DEPRESSED CENTER DESCRIPTION CODES

INOX = CONTAMINANT FREE	FC = FAST CUT	LL = LONG LIFE	HD = HEAVY DUTY	BLANK = ALL PURPOSE
■ = STAINLESS	■ = STEEL / METAL	■ = FOUNDRY	■ = MASONRY	■ = ALUMINUM



AVAILABILITY



TIER:	BETTER	BETTER	GOOD
TRADENAME:	AVOS CHARGER FLEXIBLE	CHARGER FLEXIBLE	GEMINI FLEXIBLE
SHAPE:	Type 29	Type 29	Type 27
ABRASIVE:	Aluminum Oxide	Aluminum Oxide	Aluminum Oxide
MATERIAL:	ALUMINUM STEEL / METAL	ALUMINUM STEEL / METAL	ALUMINUM STEEL / METAL

SIZE (D X T X H)	MAX. RPM	STD. PKG.	GRIT	PART NO.	PART NO.	PART NO.
1/8" FLEXIBLE – BLENDING – TYPE 29 AND 27						
2 x 1/8 x 3/8	30,560	25	60			66252835632*
		25	80			66252835633*
		25	120			66252835634*
4 x 1/8 x 5/8	13,500	20	36			66243529721#
		20	60			66243529722#
4-1/2 x 1/8 x 5/8-11	13,580	20	36	66252825236	66252833455	
4-1/2 x 1/8 x 7/8	13,580	20	36	66252823473	66252833454	
		20	46	66252823475		
		20	60	66252823474		
		12,000	20	36		
		20	60			66252830425#
5 x 1/8 x 7/8	12,225	20	36	66252823478	66252833456	
7 x 1/8 x 5/8-11	8,600	10	36		66252917052	66252939024
7 x 1/8 x 7/8	8,600	20	36		66252917051	66252939028#

* 5 WHEELS PER DISPLAY PACK; 5 DISPLAY PACKS PER STANDARD PACKAGE.
#USE WITH BACK PLATE. TWO BACK PLATES ARE INCLUDED IN EACH BOX OF 20 WHEELS.



Norton Depressed Center Adapter Kit

This reusable adapter kit contains everything you need to mount depressed center wheels and saucers with 7/8" center holes on to a portable right angle or vertical shaft grinders. Adapter hubs are threaded for mounting on to standard 5/8"-11 NCRH spindles.

KIT NO.	WHEEL DIAMETER	WHEEL THICKNESS	PART NO.	STD. PKG.
114	6" thru 9"	1/16" thru 1/4"	07660789275	1

Norton Type 01 & 27 RightCut Line – 4" - 9"

Norton RightCut wheels provide lowest total cost versus competitive initial cutting solutions for right angle grinders. Available in 4" through 9" diameters in Type 01 straight and Type 27 depressed center shapes.

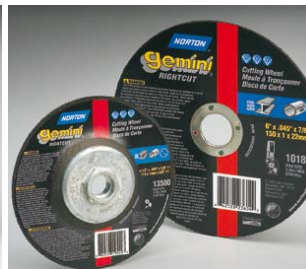

BEST NorZon Plus RightCut

Highest Productivity, Lowest Total Cost
Advanced grain technology – a blend of Norton SG® (seeded gel) ceramic alumina and NorZon zirconia alumina abrasives – in the fastest cutting bond system. Across all grinding jobs, testing shows performance up to 100% better than competitive high-performance wheels and up to 10 times better than aluminum oxide wheels.

BETTER Charger RightCut

Exceptional Blend of Performance and Price
Zirconia alumina and aluminum oxide combination provides up to 2X cut rate and up to 3X longer life over conventional aluminum oxide products on stainless and carbon steel.

GOOD Gemini RightCut

Good Performance, Wide Variety and Good Initial Price
Engineered blend of high-performance aluminum oxide provides the best starting specification on a wide variety of sizes and thicknesses at a good initial price.

GOOD Norton Metal RightCut

Good Performance, Low Initial Price
Popular aluminum oxide starting specification where good performance at a low price is the primary consideration.





NORZON PLUS

Charger

Gemini

SMALL DIAMETER REINFORCED CUT-OFF WHEELS

MACHINES USED



CATEGORY DEFINITION

The Norton small diameter cut-off wheel line consists of Type 01 straight and Type 27 depressed center cut-off wheels from 1-1/2" to 9" diameters. These wheels come in ultra thin .035 for quick burn/burr free cutting to .125" for more durable applications. All are reinforced for the demanding nature of portable cut-off.

APPLICATIONS:	Cutting sheet metal, cutting pipe, and metal plate dimensioning (metal fabrication)
SIZE RANGE:	1-1/2" – 9" diameter
THICKNESS RANGE:	.035, .040, .045, .060, .090, and .125
ABRASIVE GRAIN:	Ceramic Alumina/Zirconia Alumina, Zirconia Alumina/Aluminum Oxide, Aluminum Oxide, Silicon Carbide
SHAPE:	Type 01 Straight and Type 27 Depressed Center

TYPE-TO-APPLICATION RECOMMENDATION GUIDE

WHEEL TYPE/THICKNESS	APPLICATIONS		
TYPE 01	Type 1 cut-off wheels are designed for traditional cut-off applications. All are supplied with full fiberglass reinforcing.		
.035, .040, .045, .060	Where fast cutting and low kerf loss are desired	■	■
.090, .125	For tough cutting and notching applications where stability is important	■	■
TYPE 27	Type 27 cut-off wheels are designed with a depressed center to provide a recess for the hub, which allows flush cutting		
.040, .045, .060	Where fast cutting and low kerf loss are desired		■
.090, .125	For tough cutting and notching applications where stability is important		■

HOW TO PICK THE RIGHT BOND TYPE

All Purpose	<i>Unmarked</i>	Where an excellent blend of cut rate and life is needed
Fast Cut	FC	Where fast stock removal is needed, or the application only allows for low-pressure or under-horsepowered grinders
Long Life	LL	Where durability is needed due to severe application, and when horsepower of the grinder allows for heavy pressure
Contaminate Free	INOX	Contain <0.1% iron, sulfur or chlorine for rust-free and corrosion-free results; will not contaminate stainless steel
Aluminum	ALU	Specially formulated bond for reduced loading/surface contamination cutting aluminum/soft materials

MATERIAL-TO-PRODUCT RECOMMENDATION GUIDE

	BEST HIGHEST PRODUCTIVITY LOWEST TOTAL COST	BETTER EXCELLENT BLEND OF PERFORMANCE & PRICE	GOOD CONSISTENT PERFORMANCE LOW INITIAL PRICE
CUTTING			
Mild Carbon / High Tensile Steel	NorZon Plus	Charger	Metal
Stainless Steel / Alloys	NorZon Plus	Charger	Gemini
Contaminate Free		Charger INOX	Gemini INOX
Cast Iron	NorZon Plus	Charger	Gemini
Aluminum / Bronze / Brass			Gemini ALU
Asphalt / Brick / Concrete			Masonry



CROSS REFERENCE GUIDES

TYPE 01 .035 - .125 CUT-OFF WHEELS FOR DIE GRINDERS

	TOTAL PERFORMANCE			INITIAL PRICE		SPECIALTY	
	BEST NorZon Plus	BETTER Charger	GOOD Gemini Fast Cut	Gemini	Metal	GOOD Gemini INOX	
Brilliant	—	Brill-Max ZA	—	—	Safe-Tex FC, LL	—	
Bullard	—	ZA46T, ZA60T	TA36T	TA46T, TA60T	A36T, A60T Comp.	—	
Camel	—	ZA60-TBF	A36 RBF	A60 RBF	Fast Cut RBF	—	
Flexovit	Flexon Fast Cut A46, 60	—	High Perf Fast Grind A36	High Perf Fast Cut A36, 46, 60	—	—	
Pearl	—	SRT, Zirconia	—	Premium	Silver Line	—	
Pferd	—	—	—	—	PSF-A	SG-A-R-INOX	
Sait	Saittech	—	A60S	A24R, A36T, A60T	—	—	
SpedeCut	—	—	—	—	A46, 60 TBXX	—	
Walter	—	—	A24 ZIP	A60 ZIP	—	—	

TYPE 01 AND 27 .040 - .125 CUT-OFF WHEELS FOR RIGHT ANGLE GRINDERS

	TOTAL PERFORMANCE				INITIAL PRICE			SPECIALTY		
	BEST NorZon Plus Fast Cut	NorZon Plus	BETTER Charger Fast Cut	Charger	GOOD Gemini Fast Cut	Gemini	Metal	GOOD Gemini ALU	Gemini INOX	Masonry
Brilliant	—	—	—	—	Brill-Blade Extra FC	Brill-Blade Heavy Duty	Hornet Stinger	—	—	—
Bullard	—	—	—	ZA60T	SGA60U	TA46T, TA60T, TA60U	A46T, A60T Comp.	AL46N	—	C24R
Camel	—	—	—	ZA Quickie Cut	A36-S-BF	Super Quickie Cut	Quickie Cut	A46 Quickie Cut	A60-T-BF, WA60R Quickie Cut	—
Flexovit	—	—	—	—	Razorblade A60SST	Razorblade A24T, 30V, 36T	—	Razorblade A30Q	—	C30U
Metabo	—	—	—	A 60 XP Super Slicer	—	A 60 TX Slicer-Plus	A 60 TZ Slicer	—	—	—
Pearl	—	—	—	Redline Max Slimcut	—	Slimcut	Slimcut Pro-V, Silverline	—	—	—
Pferd	—	—	—	SGP-ZA-Q-INOX	—	SG-A-S, SGP-A-T	PSF-A-P	S-G-N-ALU	SG-A-R-INOX, SGP-A-S-INOX	SG-C-R
Sait	—	Saittech	—	Z-tech	SAIT.M.X	A60S	—	A46N	XA46R	—
SpedeCut	—	—	—	—	—	—	A46, 60 TBXX	—	—	—
Walter	—	—	—	—	A-30-ZIP	A-60-ZIP	—	A-60-ZIP-ALU	A60-SS-ZIP	C-30-ZIP

FEATURED PRODUCTS



NORZON PLUS CUT-OFF / RIGHTCUT

BEST CHOICE FOR HIGHEST PRODUCTIVITY FOR STEEL, STAINLESS STEEL AND ALL OTHER FERROUS METALS

FEATURES

- Patented Norton SG (ceramic alumina) / NorZon (zirconia alumina) grain combination
- Highly advanced bond system

BENEFITS

- Fastest cutting wheel available on the market, up to 3X faster cutting versus aluminum oxide
- 3X – 10X life versus aluminum oxide wheels on carbon steel, stainless and cast iron



CHARGER CUT-OFF / RIGHTCUT

BETTER CHOICE FOR ALL STEEL AND STAINLESS STEEL APPLICATIONS

FEATURES

- A unique blend of premium NorZon (zirconia alumina) and aluminum oxide grain

BENEFITS

- 2X – 3X the life of aluminum oxide wheels
- Up to 2X faster cutting versus aluminum oxide wheels

SMALL DIAMETER REINFORCED CUT-OFF WHEELS

MACHINES USED

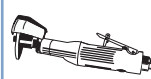

AVAILABILITY

TIER:
TRADENAME:

BEST	BETTER	BETTER	GOOD	GOOD	GOOD
NORZON PLUS	CHARGER	A60-OBNA2	GEMINI	GEMINI LONG LIFE	NORTON METAL

SHAPE:
ABRASIVE:

Type 01	Type 01	Type 01	Type 01	Type 01	Type 01
Ceramic Alumina/ Zirconia Alumina	Zirconia Alumina/ Aluminum Oxide	Aluminum Oxide	Aluminum Oxide	Aluminum Oxide	Aluminum Oxide

MATERIAL:

STAINLESS STEEL / METAL	STAINLESS STEEL / METAL	STAINLESS STEEL / METAL	STAINLESS STEEL / METAL	STAINLESS STEEL / METAL	STAINLESS STEEL / METAL
--	--	--	--	--	--

SIZE
(D X T X H)

MAX.
RPM

STD.
PKG.

PART NO.

PART NO.

PART NO.

PART NO.

PART NO.

PART NO.

TYPE 01 – CUT-OFF

SIZE (D X T X H)	MAX. RPM	STD. PKG.	PART NO.	PART NO.	PART NO.	PART NO.	PART NO.	PART NO.
1-1/2 x .035 x 1/16	40,745	25			66243427764			
1-1/2 x .035 x 1/8	40,745	25			66243427831			
1-1/2 x .035 x 1/4	40,745	25			66243427875			
2 x .035 x 1/8	30,560	25				66243411392	FC	
2 x .035 x 1/4	30,560	25			66243428014		66243411393	FC
2 x .035 x 3/8	30,560	25					66243411394	FC
2 x .060 x 1/8	30,560	25			66243428041			
2 x .060 x 1/4	30,560	25			66243427993			
2 x .060 x 1/4	30,560	25					66243411395	FC
2 x .060 x 3/8	30,560	25					66243411396	FC
2 x .125 x 1/4	30,560	25					66243411402	FC
2 x .125 x 3/8	30,560	25					66243411403	FC
2-1/2 x .035 x 1/8	30,560	25			66243528476			
2-1/2 x .035 x 1/4	30,560	25			66243528425			
2-1/2 x .060 x 1/4	30,560	25					66243510640	FC
2-1/2 x .060 x 3/8	30,560	25					66243510641	FC
2-7/8 x .035 x 1/4	25,465	25						07660789019
3 x .035 x 1/4	25,465	25	66243510668		66243528573		66243510627	FC
3 x .035 x 3/8	25,465	25	66243510669	66243527753	66243528574		66243510628	FC
3 x .060 x 1/4	25,465	25	66243510670		66243528471		66243510645	FC
3 x .060 x 3/8	25,465	25	66243510671	66243527755	66243528552		66243510647	FC
		25	66243510835	LL			66243510648	LL
3 x .125 x 1/4	25,465	25					66243510650	FC
3 x .125 x 3/8	25,465	25	66243510673				66243510652	LL
4 x .035 x 1/4	19,100	25			66243529606		66243510651	FC
4 x .035 x 3/8	19,100	25	66243510675	66243527340	66243529621		66243510653	LL
4 x .035 x 1/2	19,100	25			66243529622			
4 x .035 x 5/8	15,280	25			66243529590			
4 x .035 x 3/4	19,100	25			66243529609			
4 x .040 x 5/8	15,280	25						07660701616
4 x .045 x 5/8	15,280	25					66243527956	
4 x .060 x 1/4	19,100	25	66243510676				66243510654	FC
4 x .060 x 3/8	19,100	25	66243510677	66243527338	66243529604		66243510655	FC
4 x .090 x 5/8	15,280	25					66243527955	
4 x .125 x 1/4	19,100	25					66243510658	FC
4 x .125 x 3/8	19,100	25	66243510841	66243527339			66243510659	FC
		25	66243510680	LL			66243510661	LL
5 x .035 x 3/8	12,225	25			66252830653			
6 x .035 x 3/8	10,185	25			66252835064			
6 x .035 x 1/2	10,185	25			66252835053			
6 x .035 x 5/8	10,185	25			66252835054		66252809714	
6 x .040 x 3/8	12,225	25						66252840608
6 x .060 x 5/8	10,185	25					66252809718	
7 x .060 x 5/8	8,730	25					66252905957	
8 x .060 x 5/8	7,640	25			66253017771	LL	66253007025	
		10					66253017795	
Drill Mount Mandrel		5						07660747769*

* FOR MOUNTING 2" AND 3" x 3/8" HOLE CUT-OFF WHEELS ON TO A DRILL

CUT-OFF DESCRIPTION CODES

INOX = CONTAMINANT FREE	FC = FAST CUT	LL = LONG LIFE	BLANK = ALL PURPOSE
■ = STAINLESS	■ = STEEL / METAL	■ = MASONRY	



AVAILABILITY

TIER:
TRADENAME:
SHAPE:
ABRASIVE:
MATERIAL:

	BEST	BETTER	GOOD	GOOD
	NORZON PLUS RIGHTCUT	CHARGER RIGHTCUT	GEMINI RIGHTCUT	NORTON METAL RIGHTCUT
	Type 01	Type 01	Type 01	Type 01
	Ceramic Alumina/ Zirconia Alumina	Zirconia Alumina/ Aluminum Oxide	Aluminum Oxide	Aluminum Oxide
	STAINLESS STEEL / METAL	STAINLESS STEEL / METAL	STAINLESS STEEL / METAL	STAINLESS STEEL / METAL
	PART NO.	PART NO.	PART NO.	PART NO.

SIZE (D X T X H) MAX. RPM STD. PKG.

TYPE 01 – RIGHTCUT CUT-OFF

4 x .040 x 5/8	15,280	25				07660701616
4 x .045 x 5/8	15,280	25			66243527956	
4 x .090 x 5/8	15,280	25			66243527955	
4-1/2 x .040 x 7/8	13,580	25		66252837011		66252840001
4-1/2 x .045 x 7/8	13,580	25	66252830730	66252826569	66252823602	
		25			66252832906	
4-1/2 x .090 x 7/8	13,580	25			66252823599	
5 x .040 x 7/8	12,225	25		66252837012		
		15				07660701618
5 x .045 x 7/8	12,225	25	66252830731	66252826570	66252823603	
		25			66252832907	
5 x .090 x 7/8	12,225	25			66252823600	
6 x .040 x 3/8	12,225	25				66252840608
6 x .040 x 7/8	10,185	25				07660702757
6 x .045 x 7/8	10,185	25	66252830734	66252826571	66252823604	
		25			66252832908	
6 x .090 x 7/8	10,185	25			66252823601	
7 x .060 x 7/8	8,600	25	66252900652		66252832323	07660704732

Norton Type 01 & 27 RightCut Line – 4" - 9"

Norton RightCut wheels provide lowest total cost versus competitive initial cutting solutions for right angle grinders. Available in 4" through 9" diameters in Type 01 straight and Type 27 depressed center shapes.



BEST NorZon Plus RightCut

Highest Productivity, Lowest Total Cost
Advanced grain technology – a blend of Norton SG® (seeded gel) ceramic alumina and NorZon zirconia alumina abrasives – in the fastest cutting bond system. Across all grinding jobs, testing shows performance up to 100% better than competitive high-performance wheels and up to 10 times better than aluminum oxide wheels.



BETTER Charger RightCut

Exceptional Blend of Performance and Price
Zirconia alumina and aluminum oxide combination provides up to 2X cut rate and up to 3X longer life over conventional aluminum oxide products on stainless and carbon steel.

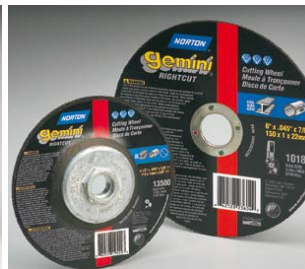

GOOD Gemini RightCut

Good Performance, Wide Variety and Good Initial Price
Engineered blend of high-performance aluminum oxide provides the best starting specification on a wide variety of sizes and thicknesses at a good initial price.



GOOD Norton Metal RightCut

Good Performance, Low Initial Price
Popular aluminum oxide starting specification where good performance at a low price is the primary consideration.



AVAILABILITY



TIER:	BEST	BETTER	GOOD	GOOD
TRADENAME:	NORZON PLUS RIGHTCUT	CHARGER PLUS RIGHTCUT	GEMINI RIGHTCUT	NORTON METAL RIGHTCUT
SHAPE:	Type 27	Type 27	Type 27	Type 27
ABRASIVE:	Ceramic Alumina/ Zirconia Alumina	Zirconia Alumina/ Aluminum Oxide	Aluminum Oxide	Aluminum Oxide
MATERIAL:	STAINLESS STEEL / METAL	STAINLESS STEEL / METAL	STAINLESS STEEL / METAL	STAINLESS STEEL / METAL

SIZE (D X T X H)	MAX. RPM	STD. PKG.	PART NO.	PART NO.	PART NO.	PART NO.
TYPE 27 – RIGHTCUT CUT-OFF						
4 x .045 x 5/8	15,280	20			66252833840	07660705249
4 x .125 x 3/8	15,280	20	66243529883			
4-1/2 x .040 x 5/8-11	13,580	20		66252837013		
4-1/2 x .045 x 5/8-11	13,580	20	66252830748	66252832009	66252819549	
4-1/2 x .045 x 7/8	13,580	20	66252830742	66252830125	66252819548	66252836497
4-1/2 x .090 x 5/8-11	13,580	20			66252823102	INOX
4-1/2 x .090 x 7/8	13,580	20			66252835320	
		20			66252823103	INOX
4-1/2 x .125 x 5/8-11	13,580	20	66252815010		66252813301	
4-1/2 x .125 x 7/8	13,580	20	66252830443		66252801860	
5 x .040 x 5/8-11	12,225	20		66252837014		
5 x .045 x 5/8-11	12,225	20			66252830586	
5 x .045 x 7/8	12,225	20	66252830744	66252830126	66252819550	
5 x .090 x 7/8	12,225	20			66252823106	INOX
		20			66252836984	LL
5 x .125 x 7/8	12,225	20			66252801862	
6 x .045 x 5/8-11	10,185	20			66252830587	
6 x .045 x 7/8	10,185	20	66252830745	66252830127	66252819551	66252840486
6 x .090 x 7/8	10,185	20			66252832487	INOX
7 x .060 x 7/8	8,600	20			66252912626	
		10				07660705251
7 x .090 x 7/8	8,600	20			66252914638	INOX
7 x .125 x 5/8-11	8,600	10	66252912625			
7 x .125 x 7/8	8,600	20			66252900619	
9 x .060 x 5/8-11	6,600	10			66253019115	

RIGHTCUT WHEELS ARE TO BE USED FOR CUTTING ONLY



TIER:	BETTER	GOOD	GOOD	GOOD
TRADENAME:	CHARGER	GEMINI	NORTON METAL	NORTON MASONRY
SHAPE:	Type 01	Type 01	Type 01	Type 01
ABRASIVE:	Zirconia Alumina/ Aluminum Oxide	Aluminum Oxide	Aluminum Oxide	Silicon Carbide
MATERIAL:	STEEEL / METAL	STEEEL / METAL	STEEEL / METAL	MASONRY

SIZE (D X T X H)	MAX. RPM	STD. PKG.	PART NO.	PART NO.	PART NO.	PART NO.
TYPE 01 – CIRCULAR SAW						
6 x .035 x 5/8	10,185	25		66252809714		
6 x .060 x 5/8	10,185	25		66252809718		
6-1/2 x 1/8 x DM-5/8	9,405	10			07660789098	07660789089
7 x .060 x 5/8	8,730	25		66252905957		
7 x 1/8 x DM-5/8	8,730	25			07660789097	07660789088
8 x .060 x 5/8	7,640	25	66253017771 LL	66253007025		
		10		66253017795		
8 x 1/8 x DM-5/8	7,640	10			07660789096	07660789086

DM DENOTES DIAMOND MOUNT; 5/8" HOLE BUSHINGS INCLUDED

CUT-OFF DESCRIPTION CODES

INOX = CONTAMINANT FREE	FC = FAST CUT	LL = LONG LIFE	BLANK = ALL PURPOSE
■ = STAINLESS	■ = STEEL / METAL	■ = MASONRY	

**HIGH SPEED
CUT-OFF WHEELS**





CATEGORY DEFINITION

Norton high speed cut-off abrasive wheels provide the industry's leading performance in all high speed gas and electric-powered applications.

APPLICATIONS:	<p>Metalworking: steel, stainless, ductile, cast iron, rail steel and metal decking</p> <p>Non-Metal Building Materials: concrete, brick, masonry, asphalt, aggregate, stone and schedule 40 and 80 PVC pipe</p> <p>Rescue and Demolition: steel, acrylic, fiberglass, rubber, glass, wood, concrete, brick and asphalt</p>
SIZE RANGE:	12" – 16" diameter
THICKNESS RANGE:	1/8"
ABRASIVE GRAIN:	Aluminum Oxide, Silicon Carbide
SHAPE:	Type 01 Straight
REINFORCEMENT:	Wheels are offered in standard two layer reinforcement as well as three layer reinforcement for higher speed saws and heavy-duty applications
ARBOR:	Wheels are offered with a patent-pending universal arbor that accommodates both 20mm (Stihl®) and all other machines with 1" arbors

MATERIAL / APPLICATION-TO-PRODUCT RECOMMENDATION GUIDE

ICON	APPLICATION
	Metal High-performance aluminum oxide grain wheels designed for general purpose cutting of all steel and stainless parts including rebar, steel pipe, structural steel, sheet metal, cable and small to medium diameter solid pieces
	Metal Decking High-performance aluminum oxide abrasive combined with a thicker wheel that stands up to the sharp edges of sheet metal and roof decking.
	Rail Steel A finer grit, harder grade aluminum oxide wheel designed for straight, fast cuts on all sizes of rail track. Additional high-performance lines of rail cut wheels are available for production applications.
	Ductile/Cast Iron A special blend of silicon carbide abrasive for cutting and aluminum oxide abrasive for life, designed to cut ductile and cast iron pipe, concrete-lined water pipes, sewer construction and heavy duty PVC.
	Rescue For ventilation, forcible entry, rescue and demolition. A versatile abrasive formula that can be used on a wide range of materials including all types of metals and masonry
	Concrete Coarse grit silicon carbide abrasive provides a low initial cost solution for cutting brick, block, concrete or other masonry materials. For higher-production applications that require optimum speed of cut and product life, please see our complete selection of high speed diamond wheels in our Norton Construction diamond product line.
	Asphalt A special blend of extra coarse silicon carbide abrasive grains provides a low initial cost solution for cutting asphalt, green concrete, asphalt over concrete, a wide range of aggregates and abrasive materials. For higher-production applications that require optimum speed of cut and product life, please see our Norton Construction diamond product line.

HOW TO PICK THE RIGHT REINFORCEMENT

	Two full layers of reinforcing are offered for lower power machines, and light to medium applications where speed of cut is the primary selection criterion.
	Three full layers of reinforcing are recommended for high speed, high horsepower machines where the application is heavy-duty, and durability is the primary selection criterion.

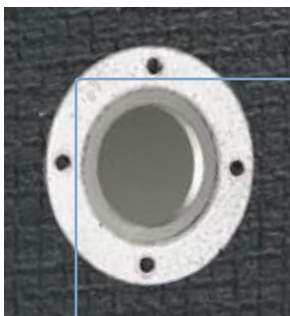

Universal Arbor

Two Blade Sizes in One

Our Norton patent-pending 1 1/20mm knock-out arbor fits all gas and electric high speed saws. A 20mm bushing is pre-mounted into the 1" molded arbor hole. The wheel, with the 20mm bushing, can be mounted directly on any 20mm arbor high speed saw. With the bushing removed, exposing the 1" arbor hole, the wheel can be mounted on any 1" arbor high speed saw. Combining this arbor, with heavy-duty triple reinforcing results in a higher performing, extra strong, longer lasting cutting wheel. Once the 20mm bushing is removed, it cannot be replaced.



CROSS REFERENCE GUIDE

SPECIALTY

NORTON

	GOOD Metal	Metal Decking	Rail Steel	Ductile	Concrete	Asphalt
Abmast	A 24 R, Kompetitor Metal	A 24 T	Rail-Kut A 24 Z	AC 24 R, Kompetitor Ductile Iron	C 24 R, Kompetitor Concrete	C 16 T, Kompetitor Asphalt
Brilliant	Metal/Stainless	—	A24PB	—	Concrete/Masonry	—
Bullard Blaze & Road Warrior	A24R, ZA24Q, The Competitor	TA24R	A30R	AC24R	C24R, The Competitor	CC20R
Camel	A24-R	A24-T	—	AC24-R	C24-R	C16-U
Flexovit	A24/30SB	A24TB	A30PB	AC24SB	C30UB	C16UB
Husqvarna	Blue XHS, Blue QMS-CM, Blue EHS	Grey QMS-CM	Yellow QMS-CM	Green QMS-CM, Green EHS	Red XHS, Red QHS-CM, Red EHS	Black QMS-AS
Pearl	SRT, Premium A36S, Silver Line A30R	—	—	AC30S	Premium C36S, Silver Line C24R	—
Pferd	A 24 R SG	A 24 Q SG-RAIL	A 24 Q SG-RAIL	AC 24 Q SG	C 24 R SG	—
Sait	A24R, A30S, XFC	Brute	Hobo	Ductile	C24R	Big M.A.C, XFC
Tyrolit	A30P, A30BF	—	—	AC24, AC30BF	1C24, C30BF	—
Virginia Abrasives	Metal	—	—	Ductile	Concrete	Asphalt
Walter	A-24	—	—	—	—	—

AVAILABILITY



TIER:	GOOD	GOOD	GOOD	GOOD	GOOD
TRADENAME:	METAL HD	METAL	METAL DECKING	RAIL STEEL	RESCUE
SHAPE:	Type 01	Type 01	Type 01	Type 01	Type 01
ABRASIVE:	Aluminum Oxide	Aluminum Oxide	Aluminum Oxide	Aluminum Oxide	Aluminum Oxide
REINFORCING:	3 layers	2 layers	2 layers	2 layers	2 layers
MATERIAL:					

SIZE D X T X H	MAX. RPM	STD. PKG.	PART NO.	PART NO.	PART NO.	PART NO.	PART NO.
TYPE 01 CUT-OFF – FOR GAS & ELECTRIC-POWERED SAWS							
12 x 1/8 x 1" / 20mm	6,360	10	66252836708	66252837838			
14 x 1/8 x 1" / 20mm	5,400	10	66252835386	66252837841	66252832521		66243578262
14 x 1/8 x 1"	5,400	10				66253260462	
16 x 1/8 x 1" / 20mm	4,800	10		66252830886			
16 x 1/8 x 1"	4,800	10				66253259935	



TIER:	GOOD	GOOD	GOOD	GOOD	GOOD
TRADENAME:	DUCTILE HD	DUCTILE	CONCRETE HD	CONCRETE	ASPHALT
SHAPE:	Type 01	Type 01	Type 01	Type 01	Type 01
ABRASIVE:	Silicon Carbide	Silicon Carbide	Silicon Carbide	Silicon Carbide	Silicon Carbide
REINFORCING:	3 layers	2 layers	3 layers	2 layers	2 layers
MATERIAL:					

SIZE D X T X H	MAX. RPM	STD. PKG.	PART NO.	PART NO.	PART NO.	PART NO.	PART NO.
TYPE 01 CUT-OFF – FOR GAS & ELECTRIC-POWERED SAWS							
12 x 1/8 x 1" / 20mm	6,360	10		66252837840	66252836709	66252837839	70184670243
14 x 1/8 x 1" / 20mm	5,400	10	66252835388	66252837843	66252835387	66252837842	70184672877
16 x 1/8 x 1" / 20mm	4,800	10				70184623029	



CATEGORY DEFINITION

The Norton RailCut line is designed for high-speed fixtured hydraulic or gas-powered rail saws.

APPLICATIONS:	Fixed rail track cutting
SIZE RANGE:	14" and 16" diameter
THICKNESS RANGE:	1/8"
GRIT RANGE:	24 – 36
ABRASIVE GRAIN:	Zirconia Alumina and Aluminum Oxide
SHAPE:	Type 01 Straight
REINFORCEMENT:	Side reinforced with R sides
SPEED RATING:	All wheels are rated for 20,000 SFPM applications

CROSS REFERENCE GUIDE AND MACHINE-TO-PRODUCT RECOMMENDATION GUIDE

NORTON	BEST	GOOD
	NorZon IV Rail FastCut and BETTER NorZon III	A30X
Bullard Abrasive	Trackmaster Pro ZA24 Q-BF (Blue)	Trackmaster A30 R-BF (Red)
Flexovit USA	-	A30-PB
Giesmar	AM303-R	NR242-Q
Klingspor	A 24 SX Special	-
Portaco	A30 R-BF	-
Racine Kwik Kut	A24R	-

	BEST	BETTER	GOOD
	HIGHEST PRODUCTIVITY / LOWEST TOTAL COST	EXCELLENT BLEND OF PERFORMANCE & PRICE	CONSISTENT PERFORMANCE / LOW INITIAL PRICE
Hydraulic Saw	NorZon IV Rail FastCut		A30X
Gas Saw			
High Horsepower / Newer Machine		NorZon III RailCut	A30X
Low Horsepower / Older Machine		NorZon III FastCut	A30X

FEATURED PRODUCTS



NORZON IV RAIL FASTCUT

BEST CHOICE FOR HIGH PERFORMANCE CUTTING OF RAILS ON APPLICATIONS WHERE THE HYDRAULIC OR GAS SAW IS FIXTURED AND HAS ADEQUATE POWER

FEATURES

- Zirconia alumina abrasive blend
- New, free cutting bond

BENEFITS

- Ideal for high powered, well-maintained machines
- Maximized cut rate, while maintaining straight cuts

AVAILABILITY

SIZE (D X T X H)	MAX. RPM	STD. PKG.	TIER:	ABRASIVE:			
				BEST	BETTER	BETTER	GOOD
			TRADENAME:	NORZON IV RAIL FASTCUT	NORZON III RAILCUT	NORZON III RAIL FASTCUT	A30X RAILCUT
			ABRASIVE:	Zirconia Alumina	Zirconia Alumina	Zirconia Alumina	Aluminum Oxide
				PART NO.	PART NO.	PART NO.	PART NO.
TYPE 01 CUT-OFF							
14 x 1/8 x 1	5,400	10		66253048511	66253360493	66253363694	66253260462
16 x 1/8 x 1	4,800	10		69936614383	66253464607	66253464415	66253259935



CATEGORY DEFINITION

These powerful, self-propelled machines are designed to cut concrete slabs and asphalt and are normally fitted with diamond blades. For inexperienced operators or small jobs, the machines can accommodate low initial cost, conventional abrasives wheels.



APPLICATIONS:	Cutting straight sections of concrete surfaces
SIZE RANGE:	14" and 18" diameter
THICKNESS RANGE:	3/16" – 3/8"
ABRASIVE GRAIN:	Silicon Carbide
SHAPE:	Type 01 Straight
BOND:	Hot Pressed (HP) – for higher horsepower machine applications where additional durability is needed, may be used wet or dry Cold Pressed (CP) – for lower horsepower machines, which need a free-cutting wheel
ARBOR:	All are 1" with a drive pin



CROSS REFERENCE GUIDE

	SPECIALTY		
	BETTER Norton Asphalt / Green Concrete – HP	GOOD Norton Asphalt	GOOD Norton Concrete
Abmast	—	C 16 T. Kompetitor Asphalt/Concrete	C 24 R
Bullard Blaze & Road Warrior	—	C16R & T, C16R3	—
Camel	—	C16-U	C24-R
Flexovit	HPC16AG	C16 G.P. C16UB	C20SB/C16TB
Husqvarna	Red GC-7A	Black EWC	Gold RTC, Blue RTC, Blue EWC
Pearl	—	—	Premium C36S, Silver Line C24R
Pferd	—	C 24 R SG ASP	C 24 R SG GP
Sait	Street Runner	C16	C24R, Street Walker
Tyrolit	Concrete/Asphalt CHP	Asphalt CP	Concrete CP
Virginia Abrasives	—	GC/Asphalt	Concrete
Walter	—	—	C-24

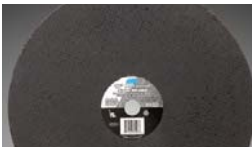
AVAILABILITY

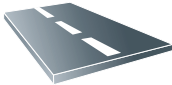
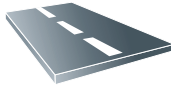
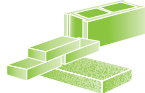
	 BETTER	 GOOD	 GOOD		
TIER:	BETTER	GOOD	GOOD		
TRADENAME:	ASPHALT – HP	ASPHALT – CP	CONCRETE		
SHAPE:	Type 01	Type 01	Type 01		
ABRASIVE:	Silicon Carbide	Silicon Carbide	Silicon Carbide		
BOND:	Hot Pressed	Cold Pressed	Cold Pressed		
MATERIAL:					
SIZE (D X T X H)	MAX. RPM	STD. PKG.	PART NO.	PART NO.	PART NO.
TYPE 01 CUT-OFF – FOR WALK-BEHIND SAWS					
14 x 3/16 x 1 Pin Hole	4,365	10	70184670100	70184680324	70184680323
14 x 1/4 x 1 Pin Hole	4,365	5	70184670099	70184670535	70184670533
18 x 1/4 x 1 Pin Hole	4,250	5	70184670103	70184670098	
18 x 3/8 x 1 Pin Hole	4,250	5	70184648998		



For higher-production applications, that require optimum speed of cut and product life, please see our complete selection of high-speed diamond blades in our Diamond, Abrasives and Equipment for the Construction Market Catalog #7719 found on www.nortonconstructionproducts.com.



NORZON PLUS

Charger

Gemini



CATEGORY DEFINITION

A chop saw is a light, low horsepower portable machine. Although very similar to a compound miter saw, it is designed for cutting denser materials, like metal bar, tubing or pipe. Chop saw cut-off wheels are designed specifically for this machine with finer grit, softer grades, and reinforcement layers that match the application.

- APPLICATIONS: Cutting small diameter metal pieces, bar stock, metal pipe, tubing, decking, cable, drywall studs, and metal plate dimensioning
- SIZE RANGE: 10" - 16" diameter
- THICKNESS RANGE: 7/64"
- ABRASIVE GRAIN: Zirconia Alumina/Aluminum Oxide Blend, Aluminum Oxide, Silicon Carbide
- SHAPE: Type O1 Straight
- REINFORCEMENT TYPE: Side reinforced, centrally reinforced

CROSS REFERENCE GUIDE

	TOTAL PERFORMANCE ←			INITIAL PRICE →			SPECIALTY →		
	BETTER			GOOD			GOOD		
NORTON	Charger Fast Cut	Charger Rapid Cut	Charger Long Life	Gemini Fast Cut	Gemini Rapid Cut	Gemini Long Life	Stud Cutter	Gemini Aluminum	Masonry
Brilliant	—	—	—	Super-G	Tube/Pipe	—	Drywall Stud	Aluminum	—
Bullard	ZA36T	—	—	TA36T A46T The Competitor	A36R The Competitor	A36R Ironmaster	A46T Studmaster	AL36R	—
Camel	—	—	ZA24-S	A36-P, WA36-P	—	A36-S	A30-R Mr. Stud	A30-N	—
Dewalt	—	—	XP	GP, Stainless Fabrication	—	—	Stud Cutting	—	—
Flexovit	—	—	—	A30R Fast Cut A30-Q Free Cut	—	A30S Long Life	A30T Drywall Stud	—	—
Makita	—	—	—	—	General Purpose	—	—	—	—
Pearl	SRT36	—	—	A36P Premium	A30P Silver Line	—	A46S Stud Cutting	—	—
Pferd	—	—	—	A 36 K SG CHOP	PSF CHOP	—	A 36 K SG-STUD	—	C 36 K SG-CHOP
Sait	Saitech Steel Worker	Z-tech	—	EZ-Chop	EZ-Chop Attacker	Iron Worker	Stud King	Aluminum	—
Walter	—	—	—	—	A-30	A-30-HC+	—	A30-ALU	—

APPLICATION-TO-PRODUCT RECOMMENDATION GUIDE

WHEEL TYPE/REINFORCEMENT

TYPE O1 STRAIGHT SIDE REINFORCED CUT-OFF WHEEL



Side reinforced wheels have two full layers of reinforcing and are designed for a fast cut and the most aggressive applications. All Purpose, Fast Cut, and Long Life are side reinforced.

TYPE O1 STRAIGHT CENTRALLY REINFORCED CUT-OFF WHEEL



Centrally reinforced wheels have a single layer of reinforcing with exposed rough sides for free-cutting, non-binding applications where minimal burr and burn are the key requirements. Rapid Cut wheels are centrally reinforced.

HOW TO PICK THE RIGHT BOND TYPE

All Purpose	UNMARKED	Where an excellent blend of cut rate and life is needed
Fast Cut	FC	Used when fast cutting is desired or when cutting pieces with larger cross sections
Long Life	LL	Where durability is needed due to severe application, and when cutting parts with small cross sections
Rapid Cut	RC	Where a free cutting, non-binding wheel is needed for burn-free and burr-free cuts
High-Performance	STUD	High-performance aluminum oxide/resin bond combination designed for cleaner cuts and longer life when cutting steel studs
Aluminum	ALU	Specially formulated bond for reduced loading/surface contamination when cutting aluminum/soft materials



FEATURED PRODUCTS



CHARGER CHOP SAW REINFORCED CUT-OFF WHEELS

BETTER CHOICE FOR STEEL, STAINLESS STEEL AND ALL OTHER FERROUS METALS

FEATURES

- Zirconia alumina/aluminum oxide abrasive blend
- Fast Cut: side reinforced
- Long Life: side reinforced
- Rapid Cut: centrally reinforced, rough sides

BENEFITS

- 2X the life and cut rate of aluminum oxide
- Engineered for larger cross-sections and/or hard-to-cut materials
- Ideal for small cross-section workpieces
- Free cutting, non-binding; burr- and burn-free cuts



GEMINI CHOP SAW REINFORCED CUT-OFF WHEELS

GOOD CHOICE FOR ALL STEEL AND FERROUS METALS AS WELL AS SPECIALTY APPLICATIONS IN ALUMINUM

FEATURES

- Fast Cut: side reinforced
- Long Life: side reinforced
- Rapid Cut: centrally reinforced, rough sides
- Aluminum: specially formulated bond for aluminum and other soft, nonferrous metals; no wax or rubber fillers

BENEFITS

- Engineered for larger cross-sections and/or hard-to-cut materials
- Ideal for small cross-section workpieces
- Free cutting, non-binding; burr- and burn-free cuts
- Free cutting; resist loading
- No surface contamination



METAL STUD CUTTER CHOP SAW REINFORCED CUT-OFF WHEELS

GOOD CHOICE FOR DRYWALL STUDS

FEATURES

- Stud Cutter: thin, side-reinforced; with high-performance aluminum oxide abrasive

BENEFITS

- Designed specifically for cutting steel studs

AVAILABILITY



TIER:	BETTER	BETTER	GOOD	GOOD	GOOD	GOOD
TRADENAME:	CHARGER	CHARGER	GEMINI	GEMINI	METAL	MASONRY
SHAPE:	Type 01	Type 01	Type 01	Type 01	Type 01	Type 01
ABRASIVE:	Zirconia Alumina/ Aluminum Oxide	Zirconia Alumina/ Aluminum Oxide	Aluminum Oxide	Aluminum Oxide	Aluminum Oxide	Silicon Carbide
REINFORCEMENT:	Side	Central	Side	Central	Side	Side
MATERIAL:	STAINLESS STEEL / METAL	STAINLESS STEEL / METAL	STAINLESS STEEL / METAL	STAINLESS STEEL / METAL	STAINLESS STEEL / METAL	MASONRY

SIZE (D X T X H)	MAX. RPM	STD. PKG.	PART NO.	PART NO.	PART NO.	PART NO.	PART NO.	PART NO.
TYPE 01 STRAIGHT CUT-OFF								
10 x 7/64 x 1	6,110	10			66253106109	LL		
12 x 7/64 x 1	5,095	10	66253207552		66253207554	LL	66253214561	RC
14 x 7/64 x 1	4,365	10	66253306624	FC	66253309614	RC	66253306627	FC
			66253306625	LL		66253306626	LL	
						66253314816	ALU	
							07660789405	STUD
							07660703970	
								07660789402
16 x 7/64 x 1	3,820	10	66253410196	FC			66253410198	LL
			66253410197	LL				

DEPRESSED CENTER DESCRIPTION CODES

FC = FAST CUT	LL = LONG LIFE	RC = RAPID CUT	ALU = ALUMINUM	STUD = STUD CUTTER
■ = STAINLESS	■ = STEEL / METAL	■ = MASONRY		



CATEGORY DEFINITION

The Norton stationary saw reinforced cut-off wheel line consists of Type 01 straight 10" - 24" wheels, designed to fit on fixed-base stationary saws that are free-standing or mounted on a workbench.

APPLICATIONS:	Primary applications are cutting of all metal parts (flat stock, bars, studs, pipes, tubes, angle iron, cable), wire rope and hydraulic hose used in fabrication, construction and plant maintenance.
SIZE RANGE:	10" – 24" diameter
THICKNESS RANGE:	3/32", 1/8", 5/32", 3/16"
ABRASIVE GRAIN:	Zirconia Alumina/Aluminium Oxide Blend, Aluminum Oxide, Silicon Carbide
SHAPE:	Type 01 Straight

CROSS REFERENCE GUIDE

	TOTAL PERFORMANCE				INITIAL PRICE	SPECIALTY
	BETTER	GOOD				GOOD
<i>NORTON</i>	Charger	Gemini Fast Cut	Gemini Long Life	Gemini Rapid Cut*	Norton Masonry	Foundry Cut**
Abmast	Z 24 R3	A 30 R	—	—	—	AC 24 R3
Brilliant	—	GP Fast Cut	GPX Long Life	XL , XLX	—	—
Bullard	—	A30-R	A30-T	A300	C20R	—
Camel	ZA24-R	A24-R, A46-T	—	—	C24-R	WA24-S
Flexovit	—	A30RB Multi Purpose	A30SB Long Life, A24TB Long Life	—	C24RB	AC24PB Heavy Duty
Metabo	—	A30N, A30R	A30S, A30V	—	C30S	—
Pearl	SRT36	A30P Premium, A30Q Silver Line	A30S Premium, A36R Premium	—	C24 Silver Line	—
Pferd	ZA 24 Q/R SG-HD	A 24 N/P SG-HD	A 24 Q/S SG-HD	—	C 24 0 SG	—
Sait	—	A24N, A36R	A24R	—	C24R	—
Tyrolit	—	A30BF	—	—	C30BF	—
Walter	—	A-24-FC	A-24-RIP	—	—	—

* FOR BURR-FREE APPLICATIONS, PLEASE REFER TO GEMINI RAPID CUT WHEELS IN CHOP SAW CUT-OFF WHEEL SECTION OR AT WWW.NORTONABRASIVES.COM
 ** FOR FOUNDRY AND OTHER PRODUCTION CUT-OFF WHEELS, PLEASE REFER TO THAT SECTION OF THE NORTON FULL LINE CATALOG #7362 OR AT WWW.NORTONABRASIVES.COM

AVAILABILITY

TIER:	BETTER	GOOD	GOOD	GOOD
TRADENAME:	CHARGER	GEMINI FAST CUT	GEMINI LONG LIFE	MASONRY
SHAPE:	Type 01	Type 01	Type 01	Type 01
ABRASIVE:	Zirconia Alumina/Aluminum Oxide	Aluminum Oxide	Aluminum Oxide	Silicon Carbide
MATERIAL:	STAINLESS STEEL / METAL	STAINLESS STEEL / METAL	STAINLESS STEEL / METAL	MASONRY

SIZE (D X T X H)	MAX. RPM	STD. PKG.	PART NO.	PART NO.	PART NO.	PART NO.
TYPE 01 STRAIGHT CUT-OFF						
10 x 3/32 x 5/8	6,110	10	66253106108	66253106101	66253106102	07660789391
12 x 1/8 x 1	5,095	10	66253207550	66253207547	66253207548	07660789350
14 x 1/8 x 1	4,365	10	66253306623	66253306609	66253306611	07660789353
16 x 1/8 x 1	3,820	10		66253422942		70184623029
16 x 5/32 x 1	3,820	10	66253410194	66253410183	66253410184	
18 x 5/32 x 1	3,015	10		66253410185		
20 x 5/32 x 1	2,710	5	69078609045 FC 69078609046 LL	69078609031	69078609032	
20 x 3/16 x 1	2,710	5		69078609033	69078609034	
24 x 3/16 x 1-3/4	2,260	5		61463650196		

DEPRESSED CENTER DESCRIPTION CODES

FC = FAST CUT	LL = LONG LIFE	BLANK = ALL PURPOSE
■ = STAINLESS	■ = STEEL / METAL	■ = MASONRY



CATEGORY DEFINITION

Foundry cut-off wheels are designed with abrasives, bonds and reinforcement types specific to machine parameters and materials.

- SIZE RANGE: Reinforced: 12" – 30" diameter; Non-reinforced: 12" – 20" diameter
- GRIT RANGE: 20 – 46 grit
- ABRASIVE GRAIN: Ceramic Alumina, Zirconia Alumina, Aluminum Oxide
- REINFORCEMENT: Strengthening fabric or filaments, which make wheels resistant to cross-bending breakage. All portable cut-off, swingframe, locked-head push-through and foundry chop stroke operations require reinforced cut-off wheels.

B: One or more full diameter pieces of filament molded inside each wheel. This construction leaves the abrasive exposed on the side of the wheel, improving freeness of cut. Used for fixed work operations with low probability of side pressure.

N: Full diameter pieces of reinforcement on the side of the wheel. Offers greatest possible resistance to side pressure and bending.

W: Reinforcement around the center hole only. These wheels are not considered to be truly reinforced.

Non-Reinforced: Designed for use on fixed-base types of machines where the work is securely clamped and guarded, and where the wheel operates on a controlled cutting plane.

SIDE PATTERNS: **Smooth sides:** Used for precision cutting applications

Rough (R) sides: Abrasive particles protrude from sides of wheel
Used wet or dry on most metals

MATERIAL-TO-PRODUCT RECOMMENDATION GUIDE

	BEST HIGHEST PRODUCTIVITY LOWEST TOTAL COST	BETTER EXCELLENT BLEND OF PERFORMANCE & PRICE	GOOD CONSISTENT PERFORMANCE LOW INITIAL PRICE
Investment Cast Alloys			
SS	B97	NZ Foundry	Foundry AP
Carbon and Alloy Steel	Norton Quantum	NZ Foundry	Foundry AP
Nickel and Cobalt Based (Hastalloy, Inconel, Waspalloy)	Norton Quantum	NZ Foundry	Foundry AP
Titanium		NZ Foundry	Foundry AP
Cast Iron		NZ Foundry Casting Cut	Foundry AP
Cast Steel			
Carbon & Low Alloy		NZ Foundry Casting Cut	Foundry AP
SS & High Alloy	Norton Quantum	NZ Foundry	Foundry AP
Aluminum Alloy			Foundry AP
Copper Alloys, Brass, Bronze		NZ Foundry Free Cut	Foundry AP

CROSS REFERENCE GUIDE

	TOTAL PERFORMANCE ←			→ INITIAL PRICE
	BEST Norton Quantum	BETTER NorZon Foundry	BETTER NorZon Foundry Casting Cut	GOOD Foundry All Purpose
NORTON				
Allison	TA362 R6 8045HA, YW462MRB2HA	TA302-T6-B6HA, A46-T6-BX5T6A	HF 1247 K – CHALLENGER	
Avery		TA30-V680		A 3226 C7A, C11922 W071
Buckeye			Steel Shark	
Dia-Tool	BV1734R 710	BV 1397-5284-C		
Flexovit		A24PB, A30RB		
Klingpor	20A24-QBF			
NATAB				T 1584 HA
Rappoid		6Z30U-B3F2		



FEATURED PRODUCTS

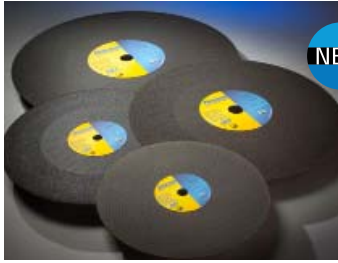

NEW

NORTON QUANTUM CERAMIC REINFORCED
BEST CHOICE ON AEROSPACE ALLOYS, CAST IRONS, AND STEEL

FEATURES

- New engineered ceramic grain shape and chemistry

BENEFITS

- Superior performance on steel, aerospace alloys, and cast iron with advanced Norton bond technology
- More aggressive; can withstand demanding applications
- Longer wheel life; shorter cycle times



NORZON FOUNDRY REINFORCED
BETTER CHOICE ON STAINLESS STEEL, AEROSPACE ALLOYS, CAST IRONS, AND STEEL

FEATURES

- Durable zirconia alumina abrasive

BENEFITS

- For premium performance on stainless steel, aerospace alloys, cast irons and steel

- New, thicker Casting Cut with extra reinforcement

NEW

AVAILABILITY REINFORCED



TIER:
TRADENAME:
ABRASIVE:

BEST	BEST	BETTER	GOOD
NORTON QUANTUM	B97	NORZON	U57A
Ceramic Alumina	Zirconia Alumina/ Aluminum Oxide	Zirconia Alumina/ Aluminum Oxide	Aluminum Oxide

SIZE (D X T X H)	MAX. RPM	STD. PKG.	SPEC.	PART NO.	SPEC.	PART NO.	SPEC.	PART NO.	SPEC.	PART NO.
TYPE O1 FLAT CUT-OFF – FOUNDRY REINFORCED										
12 x 1/8 x 1	5,095	10					AP	66253249600		
14 x 1/8 x 1	4,365	10					AP	66253319576	AP	66253464576
16 x 5/32 x 1	3,820	10	FC	61463619480	90A244-TB97N	66253422205	AP	66253466437		
			LL	61463619481			LL	66253431488		
20 x 5/32 x 1	2,710	10	FC	61463619482	90A244-YB97B	69078650375	AP	69078627986	AP	69078627989
			LL	61463619484	90A244-YB97N	69078650377	FC	69078627987		
							LL	69078627988		
							CC	69078608926		
20 x 3/16 x 1	2,710	10	FC	61463619486	90A204-YB97B	69078650380	AP	69078649613	AP	69078649612
			LL	61463619487			LL	69078627993		
24 x 7/32 x 1-3/4	2,260	10	FC	61463619488	90A204-YB97B	69083150382	AP	69083149615	AP	69083125993
			LL	61463619489			FC	69083125991	FC	69083125994
							LL	69083125992		
24 x 1/4 x 1-3/4	2,260	10					CC	69936666839		
26 x 7/32 x 1-3/4	2,090	10					U57A244-YB65B	69083166431		
30 x 1/4 x 1-3/4	1,810	10	FC	61463619492	90A204-YB97B	69210450386	4NZ24-TB65B	69210466453		
			LL	61463619493	90A204-ZB97B	69210450387	4NZ24-YB65B	69210466464		

AVAILABILITY NON-REINFORCED



TIER:
TRADENAME:
ABRASIVE:

BETTER	GOOD
U57A	GEMINI
Aluminum Oxide	Aluminum Oxide

SIZE (D X T X H)	MAX. RPM	STD. PKG.	SPEC.	PART NO.	SPEC.	PART NO.
TYPE O1 FLAT CUT-OFF – FOUNDRY NON-REINFORCED R-SIDES						
12 x 3/32 x 1	5,095	10	U57A461-PB25	66253261887		
16 x 1/8 x 1	3,820	10			AP	66253422942
20 x 1/8 x 1	2,710	10	U57A304-VB25W	69078665497		

CUT-OFF DESCRIPTION CODES

AP = ALL PURPOSE
Where an excellent blend of cut rate and life is needed

CC = CASTING CUT
Extra Reinforcement for straighter cuts

FC = FREE CUT
Where fast stock removal is needed, or the application only allows for low-pressure or under-horsepowered grinders

LL = LONG LIFE
Where durability is needed due to severe application, and when horsepower of the grinder allows for heavy pressure



CATEGORY DEFINITION

Reinforced and non-reinforced engineered cut-off wheels for cutting all types of tool steel with fixed-based cut-off machines.

APPLICATIONS:	Reinforced cut-off wheels are designed to resist breakage caused by severe cross-bending and are required on any operation where the work is not securely clamped.
	Non-Reinforced cut-off wheels are designed for use on fixed-based machines where the work is securely clamped, guarded, and where the wheel operates on a controlled cutting plane.
SIZE RANGE:	6" – 12" diameter
GRIT RANGE:	36 – 90 grit
ABRASIVE GRAIN:	Aluminum Oxide
BOND:	Resinoid, Rubber, and Shellac
SHAPE:	Type O1 Straight

CROSS REFERENCE GUIDE

NORTON	BETTER		
	Reinforced A60-OBNA2	Reinforced 57A364-TB25N	Non-Reinforced 57A60-M8B
Bates	A602-T-BF	A36-R-BF	-
Buffalo	A60-R-BF2	-	-
Dia. Tool	A80-SP	A46-SP	-
Radiac	A54-N6-B20	-	A54-N6-B20
Tyrolit	A60-QBF38A2	-	-

TECHtip

- Smooth side pattern – Used when a precise thickness tolerance is needed
- Rough (R) sides pattern – Abrasive particles protrude from sides of wheel; used wet or dry on most metals

TROUBLESHOOTING GUIDE

PROBLEM	POSSIBLE CAUSES	SUGGESTED CORRECTION
Poor cut rate	Insufficient power used Wheel too hard Contact area too large Wheel too coarse Wheel side out of truth	Increase feed or pressure to full power Use softer grade, or thinner wheel Reduce contact area Use finer grit Check spindle runout
Non-square cuts	Work not clamped properly Misaligned spindle bearings Poor coolant distribution Wheel is too hard	Check clamp and clean to remove swarf Check for bearing truth and alignment Ensure equal volume of coolant to each wheel side Use softer acting wheel: softer grade, or finer grit
Workpiece burn	Insufficient feed rate Poor coolant flow Wheel is too coarse Wheel is too hard Wheel is running out Wheel speed is too slow	Work machine to maximum power available Increase volume and direct at cutting point Use finer grit or more machine power Use softer grade wheel Check spindle and flanges Ensure tight flanges and maximum safe operating speed being used
Poor finish	Too much burr Wheel too coarse	Use finer grit, or softer grade Use finer grit

TECHtip

- Wheels with a "W" reinforcement (reinforcement around the hole) are not considered to be truly reinforced.
- Clamp or fixture the workpiece for straightest cuts
- Run wheels at the highest possible speed marked on the wheel and make cuts as quickly as possible. Do not overspeed wheels.
- It is recommended that a cut-off machine should have 1 horsepower for every inch of wheel diameter. For less than this, we recommend using a softer specification.
- Using a harder grade wheel increases wheel life, but it also increases burn, power required and decreases cut rate.
- Using a coarser grit wheel increases wheel life and cut rate, but it also increases burr and power required.

FEATURED PRODUCTS



TOOLROOM REINFORCED CUT-OFF WHEELS

BETTER CHOICE FOR CUTTING TOOL STEEL ON FIXED-BASED MACHINES WHEN WORK IS NOT SECURELY CLAMPED

FEATURES

- OBNA2 – side reinforced, resin bond
- B25N – constructed with full diameter fiberglass reinforcement

BENEFITS

- Yields maximum cut rate and minimum kerf loss; ideal when thin cut is desired
- Versatile; durable, free cutting; offer greatest stiffness

AVAILABILITY

TIER:

BETTER

SIZE (D X T X H)	MAX. RPM	STD. PKG.	SPEC.	PART NO.
TYPE 01 FLAT CUT-OFF – REINFORCED				
6 x .035 x 1/2	10,190	25	A60-OBNA2	66252835053
6 x .035 x 1-1/4	10,190	25	A60-OBNA2	66252835055
6 x .060 x 1/2	10,190	25	A60-OBNA2	66252835164
6 x .060 x 1/2	10,190	25	57A364-TB25N	66252822969
6 x .060 x 1-1/4	10,190	25	A60-OBNA2	66252835165
7 x .035 x 1/2	8,730	25	A60-OBNA2	66252938786
7 x .035 x 1-1/4	8,730	25	A60-OBNA2	66252938788
7 x .060 x 1/2	8,730	25	A60-OBNA2	66252938816
7 x .060 x 1-1/4	8,730	25	A60-OBNA2	66252938796
7 x .060 x 1-1/4	8,730	25	57A364-TB25N	66252922676

TIER:

BETTER

SIZE (D X T X H)	MAX. RPM	STD. PKG.	SPEC.	PART NO.
TYPE 01 FLAT CUT-OFF – REINFORCED				
8 x .035 x 1/2	7,640	25	A60-OBNA2	66253043014
8 x .035 x 1-1/4	7,640	25	A60-OBNA2	66253042980
8 x .060 x 1/2	7,640	25	A60-OBNA2	66253043009
8 x .060 x 1-1/4	7,640	25	A60-OBNA2	66253042983
8 x .060 x 1-1/4	7,640	25	57A364-TB25N	66253022705
10 x .060 x 5/8	6,110	25	A60-OBNA2	66253149317
10 x .060 x 1-1/4	6,110	25	A60-OBNA2	66253149186
12 x .060 x 1	5,095	10	A60-OBNA2	66253261811
12 x .075 x 1	5,095	10	A60-OBNA2	66253261910
12 x .075 x 1-1/4	5,095	10	A60-OBNA2	66253261858



TOOLROOM NON-REINFORCED CUT-OFF WHEELS

BETTER CHOICE FOR CUTTING TOOL STEEL ON FIXED-BASED MACHINES WHEN THE WORK IS SECURELY CLAMPED

FEATURES

- B bond (smooth sides)
- B25 bond (smooth sides)
- E7 bond (smooth sides)
- R30 bond (smooth sides)
- R55 bond (rough sides)

BENEFITS

- A mild acting resin bond for light cut-off applications
- A versatile, free-cutting, more durable resin bond
- Ideal for dry cutting metal in high production runs
- A shellac bond with very mild cutting action, recommended for highly critical applications where no burr, heat checks, or discoloration is permitted
- Mild acting rubber bond primarily for wet, ultra-thin cutting
- Versatile, free cutting, rubber bond used primarily for wet cut-off

AVAILABILITY

TIER:

BETTER

SIZE (D X T X H)	MAX. RPM	STD. PKG.	SPEC.	PART NO.
TYPE 01 FLAT CUT-OFF – NON-REINFORCED				
6 x .015 x 1-1/4	6,370	25	57A90-R0R30	66252822953
6 x .020 x 1-1/4	6,370	25	57A90-R0R30	66252822954
6 x .035 x 1-1/4	6,370	25	57A60-M8B	66252822958
6 x .060 x 1/2	7,640	25	57A541-RB25	66252822970
6 x .060 x 1-1/4	7,640	25	57A60-M8B	66252822975
7 x .035 x 1-1/4	5,460	25	57A60-M8B	66252922983
			57A60-Q8B	66252922986
			57A60-Q8B	66252922987
7 x .035 x 1-1/4	5,460	25	57A601-PB25	66252922988
			57A601-RB25	66252922989
7 x .035 x 1-1/4	5,185	25	57A60-OE7	66252922985
7 x .035 x 1-1/4	5,460	25	23A601-PB25	66252938701
7 x .050 x 1-1/4	5,460	25	23A601-PB25	66252938724*
7 x .060 x 1/2	6,550	25	57A60-Q8B	66252922672
7 x .060 x 1-1/4	6,550	25	57A46-M8B	66252922677
			57A60-M8B	66252922681
			57A60-Q8B	66252922684

TIER:

BETTER

SIZE (D X T X H)	MAX. RPM	STD. PKG.	SPEC.	PART NO.
TYPE 01 FLAT CUT-OFF – NON-REINFORCED				
7 x .060 x 1-1/4	5,185	25	57A60-OE7	66252922683
7 x .090 x 1-1/4	6,550	25	57A60-M8B	66252922690
7 x .125 x 1-1/4	6,550	25	57A60-M8B	66252922692
8 x .035 x 1-1/4	4,775	25	57A60-N8B	66253022694
8 x .060 x 1/2	5,730	25	57A60-M8B	66253022702
8 x .060 x 1-1/4	5,730	25	57A60-M8B	66253022708
8 x .060 x 1-1/4	4,540	25	57A60-OE7	66253022709
10 x .060 x 5/8	4,585	25	57A46-Q8BW	66253122816
			57A60-M8BW	66253122818
10 x .060 x 5/8	4,585	25	57A46-P4R55	66253122815
			57A80-P6R55	66253122819
10 x .090 x 5/8	4,585	25	57A60-M8BW	66253122824

*EXCEPTION: ROUGH SIDES



CATEGORY DEFINITION

The Norton metallurgical line of Type O1 straight cut-off wheels was developed specifically for sectioning of metal samples; burr-free cutting, minimal burn and distortion.

APPLICATIONS: Designed specifically for cutting off metal samples ranging from mild steel to super alloys on fixed-based machinery by scientists, engineers, and lab technicians

SIZE RANGE: 9" – 14" diameter

MATERIALS CUT: Steels, Nonferrous Materials, and Titanium / Titanium Alloys

CROSS REFERENCE GUIDE

SIZE	MATERIAL	Norton		Buehler		LECO		Struers	
		SPEC.	UPC	METABRASE PART NO.	BUHLERMET II PART NO.	PART NO.	PART NO.	PART NO.	AXITOM/-5 PART NO.
9 x .063 x 1-1/4 (229mm x 1.6mm x 32mm)	Very Hard Steels (Rc 55 - 68)	ML-109	66253117874	10-4110-010					60A24*
	Hard Steels (Rc 40 - 55)	ML-209	66253117875	10-4112-010	10-5110-010	811-035-010			50A24*
	Medium Steels (Rc 30 - 40)	ML-309	66253117877	10-4116-010	10-5112-010	811-043-010			40A24*
	Soft Steels (Rc 20 - 30)	ML-409	66253117828	10-4120-010	10-5116-010	811-049-010			30A24*
	Nonferrous Materials	ML-509	66253117829	10-4145-010		811-053-010			10S24*
Titanium / Titanium Alloys	ML-609	66253117878	10-4150-010		811-053-010			20S24*	
10 x .063 x 1-1/4 (254mm x 1.6mm x 32mm)	Very Hard Steels (Rc 55 - 68)	ML-110	66253117879	10-4210-010		808-673	812-231		60A25•
	Hard Steels (Rc 40 - 55)	ML-210	66253117880	10-4212-010	10-5210-010	811-059-010	810-310-010		54A25•
	Medium Steels (Rc 30 - 40)	ML-310	66253117881	10-4216-010	10-5212-010	811-067-010	810-310-010		40A25•
	Soft Steels (Rc 20 - 30)	ML-410	66253117830	10-4220-010	10-5216-010	811-073-010			30A25•
	Nonferrous Materials	ML-510	66253117831	10-4245-010	10-5245-010	810-313-010			10S25•
Titanium / Titanium Alloys	ML-610	66253117882	10-4246-010		810-313-010	811-077-010		20S25•	
12 x .078 x 1-1/4 (305mm x 2.0mm x 32mm)	Very Hard Steels (Rc 55 - 68)	ML-112	66253322151	10-4410-010		808-674	811-065-010		60A30†
	Hard Steels (Rc 40 - 55)	ML-212	66253322152	10-4412-010	10-5410-010	811-081-010	810-311-010		50A30†
	Medium Steels (Rc 30 - 40)	ML-312	66253322153	10-4416-010	10-5412-010	811-089-010	810-311-010		40A30†
	Soft Steels (Rc 20 - 30)	ML-412	66253322099	10-4420-010	10-5416-010	811-095-010	810-311-010		30A30†
	Nonferrous Materials	ML-512	66253322100	10-4445-010	10-5445-010	810-314-010			10S30†
Titanium / Titanium Alloys	ML-612	66253322154	10-4450-010		810-314-010			20S30†	
13.75 x .098 x 1-1/4 (350mm x 2.5mm x 32mm)	Very Hard Steels (Rc 55 - 68)	ML-114	66253322863	10-4310-010		808-675	812-232		60A35▲ 50A35
	Hard Steels (Rc 40 - 55)	ML-214	66253322156	10-4312-010	10-5310-010	809-346	811-977-010		50A35▲ 40A35
	Medium Steels (Rc 30 - 40)	ML-314	66253322157	10-4316-010	10-5312-010	811-976-010	811-977-010		40A35▲ 30A35
	Soft Steels (Rc 20 - 30)	ML-414	66253322158	10-4320-010		811-978-010			30A35▲ 20A35
	Nonferrous Materials	ML-514	66253322159	10-4345-010	10-5345-010	811-980-010			10S35▲ 10S35
Titanium / Titanium Alloys	ML-614	66253322160	10-4350-010		811-980-010			30S35▲ 20S35	

*DISCOTOM/LABOTOM • DISCOTOM-5/-6/LABOTOM-3 † UNITOM/DISCOTOM-50/-60/-65 ▲ EXOTOM/UNITOM-2/-5/-50

AVAILABILITY

SIZE (D X T X H)	MAX. RPM	STD. PKG.	PRODUCT NO.	APPLICATION	TIER:	
						BEST
TYPE O1 CUT-OFF – NON-REINFORCED						
9 x .063 x 1-1/4 (229mm x 1.6mm x 32mm)	4,025	10	ML-109	Very Hard Steels (Rc 55 - 68)		66253117874
			ML-209	Hard Steels (Rc 40 - 55)		66253117875
			ML-309	Medium Steels (Rc 30 - 40)		66253117877
			ML-409	Soft Steels (Rc 20 - 30)		66253117828
			ML-509	Nonferrous Materials		66253117829
10 x .063 x 1-1/4 (254mm x 1.6mm x 32mm)	3,500	10	ML-609	Titanium / Titanium Alloys		66253117878
			ML-110	Very Hard Steels (Rc 55 - 68)		66253117879
			ML-210	Hard Steels (Rc 40 - 55)		66253117880
			ML-310	Medium Steels (Rc 30 - 40)		66253117881
			ML-410	Soft Steels (Rc 20 - 30)		66253117830
12 x .078 x 1-1/4 (305mm x 2.0mm x 32mm)	3,820	10	ML-510	Nonferrous Materials		66253117831
			ML-610	Titanium / Titanium Alloys		66253117882
			ML-112	Very Hard Steels (Rc 55 - 68)		66253322151
			ML-212	Hard Steels (Rc 40 - 55)		66253322152
			ML-312	Medium Steels (Rc 30 - 40)		66253322153
13.75 x .098 x 1-1/4 (350mm x 2.5mm x 32mm)	2,770	10	ML-412	Soft Steels (Rc 20 - 30)		66253322099
			ML-512	Nonferrous Materials		66253322100
			ML-612	Titanium / Titanium Alloys		66253322154
			ML-114	Very Hard Steels (Rc 55 - 68)		66253322863
			ML-214	Hard Steels (Rc 40 - 55)		66253322156
	3,330		ML-314	Medium Steels (Rc 30 - 40)		66253322157
			ML-414	Soft Steels (Rc 20 - 30)		66253322158
			ML-514	Nonferrous Materials		66253322159
			ML-614	Titanium / Titanium Alloys		66253322160

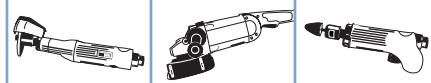

CATEGORY DEFINITION

For consistent, quality performance in foundries, welding shops, fabrication facilities, steel mills and shipyards, Norton snagging wheels maximize your productivity. Used on horizontal/straight shaft grinders or right angle cup portable grinders.

APPLICATIONS: Removing flaws, cracks, gates, risers and parting lines, smoothing weld seams, cleaning castings, and rough beveling

SIZE RANGE: Type 01 Straight Wheels: 2-1/2" – 8" diameter
Type 06 and 11 Cup Wheels: 4" – 6" diameter
Cones and Plugs: Type 16, 17, 17R, 18 and 18R

GRIT RANGE: 14 – 24

ABRASIVE TYPES: Zirconia Alumina NZ, Zirconia Alumina/Aluminum Oxide Blend AZ, Zirconia Alumina/Silicon Carbide Blend AZC, Aluminum Oxide 57A, Aluminum Oxide/Silicon Carbide Blend 57AC, Silicon Carbide 37C



MATERIAL-TO-PRODUCT RECOMMENDATION GUIDE

		BEST HIGHEST PRODUCTIVITY LOWEST TOTAL COST	BETTER EXCELLENT BLEND OF PERFORMANCE & PRICE	GOOD CONSISTENT PERFORMANCE LOW INITIAL PRICE
Iron	Gray	NorZon NZ14-R	Charger AZ14-R	Gemini 57A16-Q
	Ductile/Malleable	NorZon NZ14-R	Charger AZ14-R	Gemini 57A16-Q
	Dirty/Scale-covered		Charger AZC16-Q	Gemini 57AC16-Q
Steel	Carbon and Low Alloy	NorZon NZ16-Q	Charger AZ16-Q	Gemini 57A16-Q
	Stainless and High Alloy	NorZon NZ16-P	Charger AZ16-Q	Gemini 57A16-Q
Aluminum, Copper, Brass, & Bronze Alloys			Charger AZC16-Q	Gemini 57AC16-Q

NOTE: GRADE, GRIT AND ABRASIVE TUNING MAY BE NECESSARY TO OBTAIN OPTIMUM PERFORMANCE

CROSS REFERENCE GUIDE FOR TYPE 01, 06 AND 11

	TOTAL PERFORMANCE ←			INITIAL PRICE →		
	BEST NorZon NZ	BETTER Charger AZ	BETTER Charger AZC	GOOD Gemini 57A	GOOD Gemini 57AC	GOOD Gemini 37C
Brilliant	—	ZA16QB	—	A16QB	—	C16QB
Bullard	—	ZA16PB	—	A16R	AC16	C16P
Camel	—	—	—	A	CA	C
Flexovit	ZA16PB	—	—	A16QB	AC16QB	C16PB
Gulf States	Zirconium	—	—	A16	—	C16
Pacific	Z, Z-GPC	—	—	A	CA	—
Pearl	—	—	—	A16Q	—	C16-Q
Pferd	ZA 16 Q SG	—	—	A 16 Q SG	—	C 16 Q SG
Sait	—	Z16	—	A16, 20	CA16	C16
Tyrolit	—	—	—	A16PB	—	C16PB
Walter	—	—	—	A	—	C

FEATURED PRODUCTS



NORZON PLUS WHEELS, CONES AND PLUGS

BEST CHOICE FOR HEAVY-DUTY STOCK REMOVAL ON HIGH HORSEPOWER GRINDERS

FEATURES

- NZ (NorZon) – premium zirconia alumina grain

BENEFITS

- Engineered for high-powered machines
- 10X life, 50% faster grinding versus aluminum oxide



CHARGER SNAGGING WHEELS, CONES AND PLUGS

BETTER CHOICE FOR STOCK REMOVAL WITH MEDIUM TO LOW HORSEPOWER GRINDERS

FEATURES

- AZ – zirconia alumina/aluminum oxide blend
- AZC – zirconia alumina/silicon carbide blend

BENEFITS

- Fast, smooth grinding
- Up to 5X the life of aluminum oxide with better grinding action
- Use on dirty, scale-covered castings

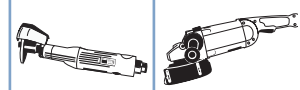

AVAILABILITY

TIER:
BRAND:
TRADENAME:
ABRASIVE:



BEST

Norton

NORZON PLUS

Zirconia Alumina



BETTER

Norton

CHARGER

Zirconia Alumina/Aluminum Oxide AZ
Zirconia Alumina/Silicon Carbide AZC



GOOD

Norton

GEMINI

Aluminum Oxide 57A
Silicon Carbide 37C
Aluminum Oxide/Silicon Carbide 57AC

SIZE (D X T X H)	MAX. RPM	STD. PKG.	SPEC	PART NO.	SPEC	PART NO.	SPEC	PART NO.
TYPE 01 STRAIGHT								
2-1/2 x 1/2 x 3/8	21,700	10					57A24-R	66243522381
3 x 1/4 x 3/8	20,370	10			AZ20-T	66243509999	57A24-T	66243528831
3 x 3/8 x 3/8	18,080	10					57A24-R	66243522415
3 x 1/2 x 3/8	18,080	10					57A24-P	66243522417
4 x 1/4 x 3/8	15,280	10			AZ20-T	66243510000	57A24-R	66243522221
6 x 1 x 5/8	8,000	5	NZ14-Q	66252838075	AZ14-R	66252809564*	57A16-QS	66252809563*
S Webs			NZ14-R	66252837961	AZC16-Q	66252837965		
8 x 3/4 x 5/8	6,000	10			AZ14-R	66253006674		
S Webs								
8 x 1 x 5/8	6,000	5	NZ16-O	66253030778	AZ14-R	66253006672*		
S Webs			NZ16-Q	66253044532	AZ14-T	66253006673*		
		10			AZC14-Q	66253030782		
					AZ16-Q	66253006670		
					AZC16-Q	66253006671		
TYPE 06 STRAIGHT CUP								
6 x 2 x 5/8-11	6,000	5	NZ16-R	66252838577				
Rim 2" Back 3/4"								
TYPE 11 FLARING CUP								
4/3 x 2 x 5/8-11	9,070	10	NZ16-Q	66243530761	AZ16-Q	66243509998	57A16-Q	66243510512
Rim 3/4" Back 3/4"								
5/3-3/4 x 2 x 5/8-11	7,260	10			AZ16-Q	66252809208	57A16-Q	66252809598
Rim 1" Back 3/4"								
6/4-3/4 x 2 x 5/8-11	6,000	5	NZ16-Q	66252838568	AZ16-P	66252825197	57A16-Q	66252825201
Rim 1" Back 3/4"			NZ16-R	66252838566				
6/4-3/4 x 2 x 5/8-11	6,000	5	NZ16-P	66252830765	AZ14-R	66252809211	37C16-P	66252809609
Rim 1-1/2" Back 3/4"					AZ16-Q	66252809209	57A16-Q	66252809618
					AZC16-Q	66252809210	57AC16-Q	66252809608
TYPE 11 FLARING CUP WITH STEEL BACK								
4/3 x 2 x 5/8-11	9,070	10			AZ16-Q	66243527807		
Rim 3/4" Back 3/4"								
5/3-13/16 x 2 x 5/8-11	7,260	10			AZ16-Q	66252823518		
Rim 1" Back 3/4"								
6/4-13/16 x 2 x 5/8-11	6,000	5			AZ14-R	66252809213	57A16-Q	66252809599
Rim 1-1/2" Back 3/4"					AZ16-Q	66252809212	57AC16-Q	66252809600
					AZC16-Q	66252825195		

*STD. PKG. = 10



AVAILABILITY

BEST	BETTER	GOOD
Norton	Norton	Norton
NORZON PLUS	CHARGER	GEMINI
Zirconia Alumina	Zirconia Alumina/Aluminum Oxide Blend	Aluminum Oxide

SIZE (D X T X H)	MAX. RPM	STD. PKG.	SPEC	PART NO.	SPEC	PART NO.	SPEC	PART NO.
TYPE 16 CONES								
1 x 3 x 3/8-24 (ME 107019)	36,290	10					57A24-R	61463622342
1-1/2 x 2-1/2 x 3/8-24 (ME 44436)	24,190	10					57A24-R	61463622349
1-1/2 x 3 x 3/8-24 (ME 139029)	24,190	10			AZ24-R	61463614587		
1-1/2 x 3 x 5/8-11 (ME 70535)	24,190	10	NZ20-R	61463644231	AZ20-R	61463614588	57A24-R	61463622190
1-3/4 x 3 x 3/8-24 (ME49226)	20,735	10					57A24-R	61463614503
1-3/4 x 3 x 5/8-11 (ME 33432)	20,740	10					57A24-R	61463622195
2 x 3 x 5/8-11 (ME 28229)	18,145	10	NZ20-R	61463644232	AZ20-R	61463614604	57A24-R	61463622218
2-3/4 x 3-1/2 x 5/8-11 (ME 18265)	13,195	10			AZ16-R	61463614599	57A24-R	61463622387
TYPE 17 CONES, SQUARE TIP								
1-1/2 / 1/2 x 3 x 3/8-24	24,190	10					57A24-R	61463622194
2 / 1/2 x 3 x 5/8-11	18,145	10					57A24-R	61463615722
TYPE 17R CONES, ROUND TIP								
2 / 3/4 x 3 x 5/8-11 (ME 151373)	18,145	10			AZ20-R	61463615866		
TYPE 18 PLUGS, SQUARE TIP								
1-1/2 x 2-1/2 x 3/8-24	24,190	10					57A24-R	61463622217
1-1/2 x 2-1/2 x 5/8-11	24,190	10	NZ20-R	61463644224	AZ20-R	61463644256	57A24-R	61463622351
1-1/2 x 3 x 5/8-11	24,190	10			AZ20-R	61463644257	57A24-R	61463622191
2 x 3 x 5/8-11	18,145	10	NZ20-R	61463644234	AZ20-R	61463614601	57A24-R	61463622219
					AZ24-R	61463614595		
2 x 4 x 5/8-11	18,145	10					57A24-R	61463622366
TYPE 18R PLUGS, ROUND TIP								
1-1/2 x 3 x 3/8-24	24,190	10					57A24-R	61463622192
2 x 3 x 5/8-11	18,145	10			AZ20-R	61463644259	57A24-R	61463622220

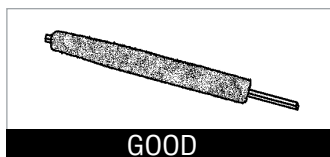

TIER: **GOOD**
 BRAND: Norton
 ABRASIVE: Silicon Carbide

SIZE (T X W X L)	STD. PKG.	SPEC	PART NO.
STOCK RESINOID CORE FILES – SILICON CARBIDE			
1/2 x 1 x 10	5	37C24-SB	61463610314

FLOORSTAND AND SWINGFRAME SNAGGING WHEELS



CATEGORY DEFINITION

Norton snagging wheels maximize your productivity in foundries, welding shops, fabrication facilities, steel mills, and ship yards.

APPLICATIONS:	Removing unwanted metal on castings, removing flaws and cracks, removing gates, risers and parting lines
SIZE RANGE:	24" and 30" diameters in stock; other diameters available as made-to-order
ABRASIVE GRAIN:	Zirconia Alumina, Zirconia Alumina/Silicon Carbide blend, Aluminum Oxide
SHAPE:	Type 01 Straight
REINFORCEMENT:	Strong fiberglass webbing and steel rings for maximum strength

FLOORSTAND SNAGGING WHEEL MATERIAL-TO-PRODUCT RECOMMENDATION GUIDE

Casting Type		BEST HIGHEST PRODUCTIVITY LOWEST TOTAL COST	BETTER EXCELLENT BLEND OF PERFORMANCE & PRICE	GOOD CONSISTENT PERFORMANCE LOW INITIAL PRICE
Iron	Gray	4ZF1434-R5B38S, ZI/25-R, ZI/26-Q	Charger Long Life	Gemini All Purpose
	Ductile / Malleable	4ZF1434-Q5B38S, ZI/25-R, ZI/26-Q	Charger Long Life	Gemini All Purpose
Steel	Carbon and Low Alloy	4NZ1434-R5B38S	Charger Free Cut	Gemini All Purpose
	Stainless and High Alloy	4NZ1634-Q5B38S	Charger Free Cut	Gemini All Purpose

NOTE: GRADE, GRIT AND ABRASIVE TUNING MAY BE NECESSARY TO OBTAIN OPTIMUM PERFORMANCE

SWINGFRAME SNAGGING WHEEL MATERIAL-TO-PRODUCT RECOMMENDATION GUIDE

Casting Type		BEST HIGHEST PRODUCTIVITY LOWEST TOTAL COST	GOOD CONSISTENT PERFORMANCE LOW INITIAL PRICE
Iron	Gray	4ZF1234-R5B38S, ZI/25-R, ZI/26-Q	Gemini All Purpose
	Ductile / Malleable	4ZF1234-R5B38S, ZI/25-R, ZI/26-Q	Gemini All Purpose
Steel	Carbon and Low Alloy	4ZF1434-R5B38S	Gemini All Purpose
	Stainless and High Alloy		Gemini All Purpose
Aluminum Alloy		NZC142-R5B38S	
Copper Alloys / Brass / Bronze		NZC142-R5B38S	

NOTE: GRADE, GRIT AND ABRASIVE TUNING MAY BE NECESSARY TO OBTAIN OPTIMUM PERFORMANCE

TROUBLESHOOTING GUIDE

PROBLEM	POSSIBLE CAUSES	SUGGESTED CORRECTION
Poor stock removal	Insufficient pressure applied Wheel too coarse or hard Inadequate abrasive	Increase pressure to use all available power Use finer grit and/or softer grade wheel Try NorZon, 4ZF, or ZI/25 specification
Grinding costs too high	Wheel acting too soft Low performance specification	Use harder and/or coarser wheel Try NorZon or ZI products
Wheel loading or glazing	Grade too hard Grit too coarse Dirty, scale-covered parts	Try softer grade Try finer grit Try NZC wheels
Wheels "dusty"	Wheel too soft	Try harder grade
Wheel doesn't hold corner or wheel spalling	Wheel too coarse Wheel too soft	Use finer grit and/or 2 grit combination Use harder grade
Burning the workpiece	Wheel too hard Wheel glazed or loaded Grinding pressure too low Grinding pressure too high	Use softer grade Dress the wheel face Increase grinding force Reduce grinding force
Surface finish too rough	Wheel too coarse Wheel speed too slow Worn machine bearings	Try finer grit or try ZI/26 specification Try higher speed machine (Do not exceed maximum operating speed of wheel) Rebuild machine
Vibration	Wheel worn out of round Faulty flanges Bent machine spindle Worn machine bearings	Try truing the wheel Check flanges for flatness and burrs (see ANSI B7.1) Check spindle run-out Rebuild machine
Wheel stalls or slows	Grinding force too high Wheel too hard Machine power too low	Reduce pressure or contact area Use softer grade wheel Replace machine with higher power grinder

FEATURED PRODUCTS

4ZF, 4NZ, ZI, AND NZC WHEELS

BEST CHOICE FOR DEMANDING APPLICATIONS

FEATURES

- 4ZF – for long life
- 4NZ – for sharpness
- NEW! ZI – new zirconia grain stays sharper, longer
- NZC – zirconia alumina and silicon carbide blend

BENEFITS

- Engineered for high-pressure, heavy-duty, snagging operations, particularly on iron
- Exceptional wheel life
- Developed for low- to medium-pressure operations, especially on steel and steel castings
- Exceptionally high cut rate
- The most operator-friendly wheels
- The choice for iron castings: ZI/25 for tough metal removal, ZI/26 for finer surface finish
- Ideal for dirty, scale-covered castings

CHARGER WHEELS

BETTER CHOICE FOR STRONG PERFORMANCE TO PRICE RATIO

FEATURES

- Strong zirconia alumina abrasive

BENEFITS

- Very good cut rate and life

5ZF AND GEMINI WHEELS

GOOD CHOICE FOR NUMEROUS SMALL JOBS

FEATURES

- Gemini – versatile aluminum oxide formulation
- Competitively priced
- 5ZF – zirconia alumina

BENEFITS

- Works well with a variety of machines, horsepower, and operations
- The choice for initial-price-conscious end-users
- Ideal for lower horsepower or low-pressure applications

AVAILABILITY

AVAILABILITY		TIER:	BEST		BETTER		GOOD	
SIZE STD. (D X T X H)	MAX. RPM	PKG.	SPEC.	PART NO.	SPEC.	PART NO.	SPEC.	PART NO.
TYPE 01 STRAIGHT								
24 x 3 x 12	1,990	1	4ZF1234-R5B38S	69083166310			5ZF14-QS	69083166858
HS Steel Rings with Fine Centers, S Webs		1	ZI/25-R	66253119637			5ZF14-QS	69083123732*
		1	ZI/26-Q	66253119639			Gemini All Purp.	69083167173
30 x 2 x 12	1,595	1	4NZ1634-Q5B38S	69210421412	Charger Free Cut	69210421417	5ZF14-R	69210467105
HS Steel Rings with Fine Centers, S Webs			4ZF1434-R5B38S	69210466458	Charger Long Life	69210421418	Gemini All Purp.	69210417463
			4ZF1634-Q5B38S	69210466460				
			ZI/25-R	66253119636				
			ZI/26-Q	66253119638				
			NZC142-R5B38S	69210421414				

* PACKAGED 10 WHEELS PER PALLET. MUST BE ORDERED IN MULTIPLES OF 10.

FOR YOUR SAFETY: ALL FLOORSTAND AND SWINGFRAME WHEELS HAVE STRONG FINE CENTERS, STEEL RINGS AND HIGH-STRENGTH FIBERGLASS REINFORCEMENT CONSTRUCTION.

TECHtip

- Always ensure proper mounting of floorstand and swingframe wheels by mounting with arrow down as marked on wheel.
- Always use safety guard.
- Always run wheel for 1 minute before grinding.
- For optimum performance, ensure adequate air pressure and air volume when using pneumatic machines.
- Use constant surface foot per minute machines for highest efficiency.
- Do not overdress the wheel face.
- Avoid loading or glazing by changing the contact angle.
- Use pressure assist whenever possible to obtain maximum cut rate.



It is the user's responsibility to refer to and comply with ANSI B7.1



CATEGORY DEFINITION

The Norton Bench and Pedestal wheel line consists of all wheel diameters and arbor sizes, abrasive types and grit sizes – to answer all your metal removal, deburring, shaping and sharpening needs: white aluminum oxide for high speed tool steels, gray aluminum oxide for carbon steel, and silicon carbide for nonferrous metals and carbide tooling.

- APPLICATIONS: Offhand deburring and sharpening of parts and tools
- SIZE RANGE: 5" – 18"
- GRIT RANGE: 24 – 150
- ABRASIVE TYPES: Aluminum Oxide, Silicon Carbide
- BUSHINGS: Telescopic arbor bushings to fit all popular grinders are packaged with the wheel

APPLICATION/GRIT RECOMMENDATION GUIDE

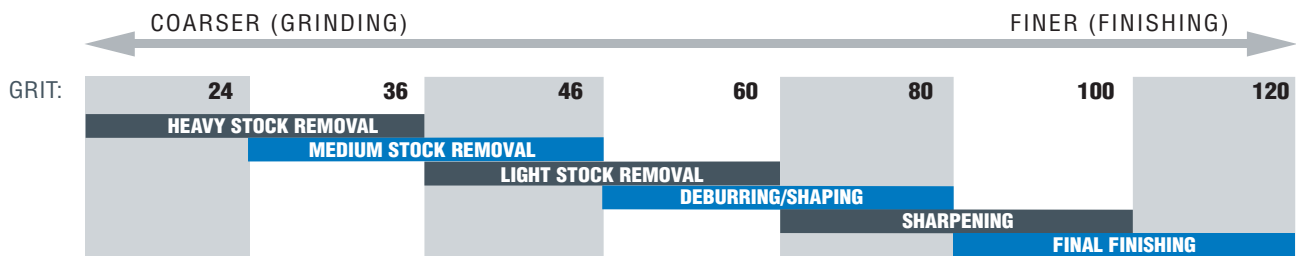

FEATURED PRODUCTS



PREMIUM WHITE ALUMINUM OXIDE

BETTER CHOICE FOR LIGHT METAL REMOVAL AND SHARPENING OF HIGH SPEED TOOL STEELS (55 RC AND HIGHER)

FEATURES

- White aluminum oxide in a premium vitrified bond

BENEFITS

- Maximum cut rate and cool grinding action on hardened or high-speed tool steels



57A AND 39C ENGINEERED

BETTER CHOICE FOR END USER THAT NEEDS SPECIFIC GRIT SIZE AND HARDNESS FOR ENGINEERED APPLICATIONS

FEATURES

- High quality aluminum oxide or silicon carbide abrasive in a premium vitrified bond system

BENEFITS

- Precision engineered grit size and hardness to maximize cut rate, finish and wheel life
- 57A for ferrous metals: 39C for nonferrous materials
- Non-stock available by calling customer service



GEMINI ALUMINUM OXIDE

GOOD CHOICE FOR ALL GENERAL-PURPOSE BENCH AND PEDESTAL APPLICATIONS ON METAL

FEATURES

- Quality, gray aluminum oxide

BENEFITS

- Economical prices; ideal for small job shops and numerous general-purpose applications



GEMINI SILICON CARBIDE

GOOD CHOICE FOR ALL GENERAL-PURPOSE BENCH AND PEDESTAL APPLICATIONS ON NONFERROUS MATERIALS AND CARBIDE TOOLING

FEATURES

- Sharp, green silicon carbide

BENEFITS

- Economical prices; ideal for small job shops and numerous general-purpose applications

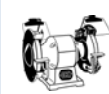

AVAILABILITY



TIER: **BETTER**
 BRAND: Norton
 TRADENAME: **PREMIUM ALUNDUM**
 ABRASIVE: White Aluminum Oxide



TIER: **BETTER**
 BRAND: Norton
 TRADENAME: **57A**
 ABRASIVE: Aluminum Oxide



TIER: **GOOD**
 BRAND: Norton
 TRADENAME: **GEMINI ALUNDUM**
 ABRASIVE: Aluminum Oxide

SIZE (D X T X H)	MAX. RPM	MIN./ STD. PKG.	PART NO.		MIN./ STD. PKG.	PART NO.		MIN./ STD. PKG.	PART NO.	
5 x 1/2 x 1	4,965							1/5	Medium 60/80 Fine 100/120	07660788202 07660788201
5 x 3/4 x 1	4,965							1/5	Coarse 36/46 Medium 60/80 Fine 100/120	07660788215 07660788210 07660788205
5 x 1 x 1	4,965							1/5	Coarse 36/46 Medium 60/80	07660788230 07660788225
6 x 1/2 x 1	4,140							1/5	Coarse 36/46 Medium 60/80 Fine 100/120	66252836132 66252836131 66252836133
6 x 3/4 x 1	4,140	1/5	Medium 60 Fine 100 Very Fine 150	07660788246 07660788247 07660788248					Coarse 36/46 Medium 60/80 Fine 100/120	07660788245 07660788240 07660788235
6 x 1 x 1	4,140	1/5	Medium 60 Fine 100 Very Fine 150	07660788261 07660788262 07660788263					Coarse 36/46 Medium 60/80 Fine 100/120	07660788260 07660788255 07660788250
7 x 1 x 1	3,600							1/5	Coarse 36/46 Medium 60/80 Fine 100/120	07660788275 07660788270 07660788265
8 x 3/4 x 1	3,600							1/5	Coarse 36/46 Medium 60/80 Fine 100/120	07660788278 07660788277 66253042317
8 x 1 x 1	3,600	1/5	Medium 60 Fine 100 Very Fine 150	07660788281 07660788282 07660788283					Very Coarse 24 Coarse 36/46 Medium 60/80 Fine 100/120	66253044454 07660788286 07660788285 07660788280
10 x 1 x 1-1/4	2,485				1/5	57A46-MVBE 57A60-MVBE	66253116274 66253116273	1/2	Very Coarse 24 Coarse 36/46 Medium 60/80 Fine 100/120	66253160788 07660788295 07660788290 66253160350
10 x 1-1/4 x 1-1/4	2,485							1/2	Coarse 36/46 Medium 60/80	66253161250 66253161251
10 x 1-1/2 x 1-1/4	2,485				1/5	57A46-MVBE	66253116280	1/2	Coarse 36/46 Medium 60/80	66253161393 66253161395
12 x 1 x 1-1/4	2,070				1/5	57A46-MVBE	66253220947			
12 x 1-1/2 x 1-1/2	2,070							1/2	Coarse 36/46 Medium 60/80	66253263052 66253263053
12 x 2 x 1-1/2	2,070				1/4	57A30-MVBE 57A36-OVBE 57A46-MVBE 57A60-MVBE	66253220951 66253220952 66253220953 66253220955	1/2	Very Coarse 24 Coarse 36/46 Medium 60/80	66253263054 66253263055 66253263056
14 x 2 x 1-1/2	1,800				1/3	57A24-QVBE 57A36-OVBE 57A46-MVBE	66253319972 66253319973 66253319974			
14 x 2-1/2 x 1-1/2	1,800				1/2	57A24-QVBE 57A46-MVBE	66253319976 66253319975			
14 x 3 x 1-1/2	1,800				1/2	57A36-OVBE	66253319977			
18 x 3 x 1-1/2	1,275				1/2	57A24-QVBE	66253462610			



AVAILABILITY



BETTER

Norton

39C/37C

Silicon Carbide



GOOD

Norton

GEMINI CRYSTOLON

Silicon Carbide

TIER:
BRAND:
TRADENAME:
ABRASIVE:

SIZE (D X T X H)	MAX. RPM	MIN./STD. PKG.	PART NO.		MIN./STD. PKG.	PART NO.	
6 x 1/2 x 1	4,140				1/5	Medium 60 Fine 80 Extra Fine 120	66252836571 66252836572 66252836573
6 x 3/4 x 1	4,140				1/5	Medium 60 Fine 80 Extra Fine 120	66252837190 66252837191 66252837192
6 x 1 x 1	4,140				1/5	Medium 60 Fine 80 Extra Fine 120	66252837187 66252837193 66252837194
7 x 1 x 1	3,600				1/5	Medium 60 Fine 80 Extra Fine 120	66252942300 66252942301 66252942302
8 x 1 x 1	3,600				1/5	Medium 60 Fine 80 Extra Fine 120	66253044087 66253044534 66253044535
10 x 1 x 1-1/4	2,485	1/5	39C60-IVK	66253116262	1/2	Medium 60 Fine 80	66253144536 66253160366
10 x 1-1/2 x 1-1/4	2,485	1/5	39C60-IVK	66253116265			
12 x 2 x 1-1/4	2,070				1/2	Medium 60 Fine 80	66253263359 66253263360
12 x 2 x 1-1/2	2,070	1/4	39C60-KVK	66253220942			
14 x 2 x 1-1/2	1,800	1/3	37C24-RVK	66253319967			

Bench and Pedestal Wheel Arbor Bushings

WHEEL DIAMETER	WHEEL CENTER HOLE	1/2"	5/8"	3/4"	7/8"	1"	1-1/4"
5", 6", 7"	1"	•	•	•	•		
8"	1"		•	•	•		
10"	1-1/4"			•	•	•	
12" X 1"	1-1/4"			•	•	•	
12" X 2"	1-1/4"					•	
12"	1-1/2"					•	•
14"	1-1/2"					•	•

THESE SIZE BUSHINGS SHIPPED FREE OF CHARGE WITH YOUR WHEEL ORDER.

TECHtip

- All bench and pedestal wheels must be dressed to prevent loading. Loading can cause excessive heat, damage to the workpiece, and wheel breakage. Dressing exposes new cutting edges and provides chip clearance.
- Recommended Starting Dressing Stick: 1 x 1 x 6 37C24-SVK Part No. 61463610462. Single Point Dressing Tools may also be used. See Dressing Stick and Diamond Tool sections for additional recommendations.
- Do not grind wood, plastic or any other non-metallic material on a bench or pedestal grinder.
- Unsecured machines can move, causing grinding breakage and injury. Fixed-based bench and pedestal grinders MUST be secured.



It is the user's responsibility to refer to and comply with ANSI B7.1



CATEGORY DEFINITION

Resin bond, vitrified bond, center lap, and cotton fiber mounted points are available in a wide range of shapes.

- INDUSTRIES:
- Aerospace
 - Tool and Die
 - Construction
 - Metal Fabrication
 - Automotive
 - Cutlery
 - Mold Shops
 - Stainless Steel Equipment
 - Foundries

ABRASIVE GRAIN: Ceramic Alumina, Zirconia Alumina, Aluminum Oxide, Silicon Carbide

SHAPE AVAILABILITY: A, B, and W



MEASUREMENT GUIDE

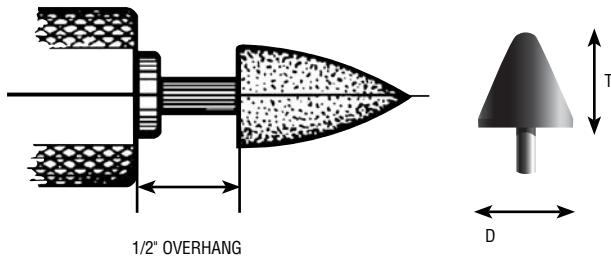

DESCRIPTION OF OVERHANG

Overhang is the distance between the grinder chuck and the abrasive on the spindle. The larger the overhang, the lower the maximum safe operating speed.

SIZE

Measured by diameter (D) x thickness (T)

FEATURED PRODUCTS



CENTER LAP MOUNTED POINTS FOR EXCELL-O CENTER LAP AND SIMILAR MACHINES

FEATURES

- Specially formulated wheel treatment (#5 wood resin)
- Larger diameter spindle
- Precise dimensional tolerances

BENEFITS

- Adds lubricity to the wheel, minimizing risk of metallurgical damage
- Minimum deflection, rigid support
- Ensure accurate location of part centers

AVAILABILITY

TIER:	BETTER
BRAND:	Norton
TRADENAME:	CENTER LAP
ABRASIVE:	Aluminum Oxide

SHAPE	SIZE (D X T)	SPINDLE DIA. †	MAX. RPM*	MIN./STD. PKG.	SPEC	PART NO.
CENTER LAP MOUNTED POINTS						
–	1/2 x 2**	1/2	65,000	5/25	A80-VVM	61463621421
–	1 x 2**	1/2	15,900	5/25	A80-VVM	61463622926

** POINTED 60°

† SPINDLE LENGTH IS 1-1/4"

* MAXIMUM OPERATING SPEED BASED ON 1/2" OVERHANG

TECHtip

Dress the center lap mounted points frequently to ensure accurate and smooth center holes.



It is the user's responsibility to refer to and comply with ANSI B7.1



COTTON FIBER MOUNTED POINTS

GOOD FOR BLENDING AND POLISHING

FEATURES

- 80 grit
- 120 grit

BENEFITS

- For most materials
- For polishing and stainless steel applications

AVAILABILITY

TIER:	GOOD
BRAND:	Norton
TRADENAME:	COTTON FIBER
ABRASIVE:	Aluminum Oxide

SHAPE	SIZE (D X T)	SPINDLE DIA. †	MAX. RPM*	MIN./STD. PKG.	SPEC	PART NO.
COTTON FIBER MOUNTED POINTS						
A11	7/8 x 2	1/4	25,420	25/25	A80-HBF3	61463622664
B52	3/8 x 3/4	1/8	64,810	25/25	A120-HBF3	61463620242
B121	1/2" Ball	1/8	62,420	25/25	A80-HBF3	61463622657
W163	1/4 x 1/2	1/8	59,990	25/25	A80-HBF3 A120-HBF3	61463622655 61463622656
W176	3/8 x 1/2	1/8	50,460	25/25	A80-HBF3	61463622654
W185	1/2 x 1/2	1/8	42,750	25/25	A80-HBF3	61463622649
W187	1/2 x 1	1/8	22,630	25/25	A80-HBF3	61463622651
W220	1 x 1	1/4	30,370	25/25	A80-HBF3	61463622646

† SPINDLE LENGTH IS 1-1/2" * MAXIMUM OPERATING SPEED BASED ON 1/2" OVERHANG

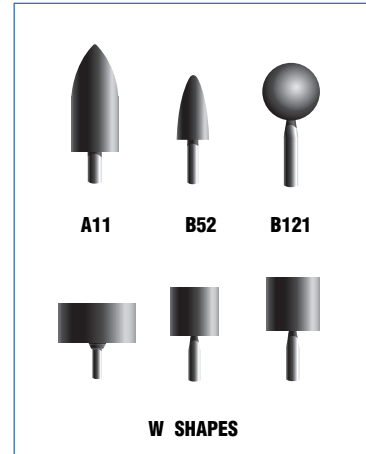

NORZON – RESIN BOND MOUNTED POINTS

BEST CHOICE FOR FAST STOCK REMOVAL

FEATURES

- NZ (NorZon) zirconia alumina self-sharpening abrasive and durable organic bond
- 2X faster stock removal than competitive aluminum oxide products
- Last 4X longer



CHARGER – RESIN BOND MOUNTED POINTS

BETTER CHOICE FOR FAST STOCK REMOVAL AND LONG LIFE

FEATURES

- Zirconia alumina / aluminum oxide abrasive blend
- 35% faster cut rate than standard aluminum oxide
- An aggressive, free cut
- More parts cleaned in less time to substantially increase productivity
- Specially formulated organic bond
- 2X greater life than ordinary aluminum oxide
- Reduces vibration and wheel chatter

AVAILABILITY

TIER:	BEST	BETTER
BRAND:	Norton	Norton
TRADENAME:	NORZON	CHARGER
ABRASIVE:	Zirconia Alumina	Zirconia Alumina/Aluminum Oxide

SHAPE	SIZE (D X T)	SPINDLE DIA. †	MAX. RPM*	MIN./STD. PKG.	SPEC	PART NO.	SPEC	PART NO.
RESIN BOND MOUNTED POINTS								
A1	3/4 x 2-1/2	1/4	20,960	5/25	NZ24-UBXR1	61463616457	Charger	61463616458
A3	1 x 2-3/4	1/4	15,530	5/25	NZ24-UBXR1	61463616459	Charger	61463616460
A5	3/4 x 1-1/8	1/4	38,550	5/25			Charger	61463616462
A11	7/8 x 2	1/4	25,420	5/25	NZ24-UBXR1	61463616463	Charger	61463616464
W189	1/2 x 2	1/4	26,830	5/25	NZ24-UBXR1	61463616465	Charger	61463616466
W197	5/8 x 2	1/4	24,550	5/25	NZ24-UBXR1	61463616467		
W207	3/4 x 1-1/2	1/4	27,070	5/25			Charger	61463616470
W208	3/4 x 2	1/4	22,830	5/25	NZ24-UBXR1	61463616471	Charger	61463616472
W220	1 x 1	1/4	30,370	5/25	NZ24-UBXR1	61463617520	Charger	61463617521
W221	1 x 1-1/2	1/4	24,490	5/25	NZ24-UBXR1	61463616473	Charger	61463616474
W222	1 x 2	1/4	20,250	5/25	NZ24-UBXR1	61463616475	Charger	61463616476

† SPINDLE LENGTH IS 1-1/2" * MAXIMUM OPERATING SPEED BASED ON 1/2" OVERHANG

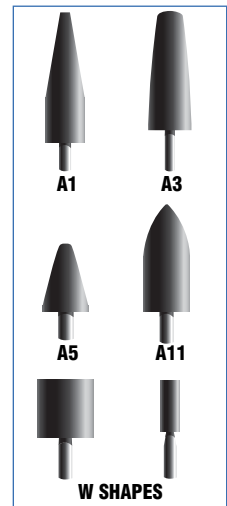



NORTON QUANTUM (NQ) – VITRIFIED BOND MOUNTED POINTS

BEST CHOICE FOR HIGH VOLUME OPERATIONS

FEATURES

- Unique, engineered ceramic grain shape and chemistry with proven bond technology

BENEFITS

- Ideal for high-volume foundry operations – grinding Inconel and similar alloy turbine blade components
- Minimal loading and heat build-up
- 33% + longer life vs. competitive ceramic products
- 30% + higher metal removal rates
- Versatile, optimized for all low-, medium- and high-force applications
- Exceptional productivity and life



GEMINI – VITRIFIED BOND MOUNTED POINTS

GOOD VALUE FOR GENERAL PURPOSE, SMALL JOB SHOP APPLICATIONS

FEATURES

- 38A abrasive
- Diverse shapes and sizes

BENEFITS

- Cool cutting, less burn
- Ideal when initial price is the main purchasing consideration

AVAILABILITY

TIER:	BEST	GOOD
BRAND:	Norton	Norton
TRADENAME:	QUANTUM	GEMINI
ABRASIVE:	Ceramic Alumina	38A

SHAPE	SIZE (D X T)	SPINDLE DIA. †	MAX. RPM*	MIN./STD. PKG.	SPEC	PART NO.	SPEC	PART NO.
VITRIFIED BOND MOUNTED POINTS – A SHAPES								
A1	3/4 x 2-1/2	1/4	20,960	5/25	3NQ80	69083149139	38A36-T	61463624374
A1	3/4 x 2-1/2	1/4	20,960	5/25			38A60-P	61463624375
A3	1 x 2-3/4	1/4	15,530	5/25			38A36-T	61463624377
A3	1 x 2-3/4	1/4	15,530	5/25			38A60-P	61463624378
A4	1-1/4 x 1-1/4	1/4	28,550	5/25			38A60-P	61463624380
A5	3/4 x 1-1/8	1/4	38,550	5/25			38A36-T	61463624381
A5	3/4 x 1-1/8	1/4	38,550	5/25			38A60-P	61463624382
A11	7/8 x 2	1/4	25,420	5/25	3NQ80	69083149141	38A36-T	61463624384
A11	7/8 x 2	1/4	25,420	5/25			38A60-P	61463624385
A12	11/16 x 1-1/4	1/4	38,050	5/25	3NQ60	61463677679		
A12	11/16 x 1-1/4	1/4	38,050	5/25			38A60-P	61463624388
A13	1-1/8 x 1-1/8	1/4	31,850	5/25			38A60-P	61463624389
A14	11/16 x 7/8	1/4	43,440	5/25			38A60-P	61463624390
A15	1/4 x 1-1/16	1/4	50,510	5/25			38A60-P	61463624391
A21	1 x 1	1/4	35,510	5/25	3NQ80	69083149144	38A60-P	61463624392
A23	3/4 x 1	1/4	40,300	5/25	3NQ80	69083149143	38A60-P	61463624394
A24	1/4 x 3/4	1/4	56,000	5/25			38A60-P	61463624395
A25	1" Ball	1/4	35,510	5/25	3NQ80	61463677680	38A60-P	61463624396
A26	5/8" Ball	1/4	48,980	5/25	3NQ80	69083149145	38A60-P	61463624397
A31	1-3/8 x 1	1/4	27,780	5/25			38A60-P	61463624399
A34	1-1/2 x 3/8	1/4	25,460	5/25			38A60-P	61463624402
A36	1-5/8 x 3/8	1/4	23,510	5/25	3NQ80	69083149146	38A60-P	61463624404
A37	1-1/4 x 1/4	1/4	30,560	5/25			38A60-P	61463624405
A38	1 x 1	1/4	35,510	5/25	3NQ80	61463677682	38A60-P	61463624406
A39	3/4 x 3/4	1/4	44,030	5/25	3NQ80	69083149147	38A60-P	61463624407
A40	3/4" Ball	1/4	44,030	5/25			38A60-P	61463624408

† STANDARD SPINDLE SIZE IS 1/4" x 1-1/2"

* MAXIMUM OPERATING SPEED BASED ON 1/2" OVERHANG





AVAILABILITY

TIER:	BEST	GOOD
BRAND:	Norton	Norton
TRADENAME:	QUANTUM	GEMINI
ABRASIVE:	Ceramic Alumina	38A

SHAPE	SIZE (D X T)	SPINDLE DIA. †	MAX. RPM*	MIN./STD. PKG.	SPEC	PART NO.	SPEC	PART NO.
VITRIFIED BOND MOUNTED POINTS – B SHAPES								
B41	5/8 x 5/8	1/8	59,560	5/25			38A60-P	61463624410
B42	1/2 X 3/4	1/8	61,320	5/25	3NQ80	69083149045	38A60-P	61463624412
B43	1/4 x 5/16	1/8	76,160	5/25			38A60-P	61463624413
B44	7/32 x 3/8	1/8	75,840	5/25			38A60-P	61463624414
B45	3/16 x 5/16	1/8	79,600	5/25			38A60-P	61463624415
B46	1/8 x 5/16	1/8	83,530	5/25			38A60-P	61463624416
B51	7/16 x 3/4	1/8	62,820	5/25			38A60-P	61463624418
B52	3/8 x 3/4	1/8	64,810	5/25	3NQ80	69083149046	38A60-P	61463624420
B52	3/8 x 3/4	1/4	78,340	5/25			38A60-P	61463624419
B52	3/8 x 3/4	1/8	64,810	5/25			38A90-Q	61463624422
B53	5/16 x 5/8	1/8	67,070	5/25			38A60-P	61463624423
B54	1/4 x 1/2	1/8	71,340	5/25			38A60-P	61463624424
B55	1/8 x 1/4	1/8	85,900	5/25			38A60-P	61463624425
B81	3/4 x 3/16	1/8	50,930	5/25			38A60-P	61463624437
B91	1/2 x 5/8	1/8	61,110	5/25			38A60-P	61463624443
B96	1/8 x 1/4	1/8	85,900	5/25			38A60-P	61463624448
B96	1/8 x 1/4	1/8	85,900	5/25			38A90-Q	61463624449
B97	1/8 x 3/8	1/8	81,550	5/25	3NQ80	69083149048	38A60-P	61463624451
B98	3/32 x 1/4	1/8	88,040	5/25			38A60-P	61463624452
B121	1/2" Ball	1/8	62,420	5/25			38A60-P	61463624466
B122	3/8" Ball	1/8	68,740	5/25	3NQ80	69083149050	38A60-P	61463624470
B122	3/8" Ball	1/8	68,740	5/25			38A90-Q	61463624471
B123	3/16" Ball	1/8	84,720	5/25			38A60-P	61463624472
B124	1/8" Ball	1/8	91,770	5/25			38A90-Q	61463624474
B131	1/2 x 1/2	1/8	62,420	5/25	3NQ80	69083149049	38A60-P	61463624475
B132	3/8 x 1/2	1/8	65,910	5/25			38A60-P	61463624479
B133	3/8 x 3/8	1/8	68,740	5/25			38A60-P	61463624481
B134	5/16 x 3/8	1/8	71,220	5/25			38A60-P	61463624482
B135	1/4 x 1/2	1/8	71,340	5/25			38A60-P	61463624484
B136	1/4 x 5/16	1/8	76,160	5/25			38A60-P	61463624485

† STANDARD SPINDLE SIZE IS 1/8" OR 1/4" x 1-1/2"
 * MAXIMUM OPERATING SPEED BASED ON 1/2" OVERHANG

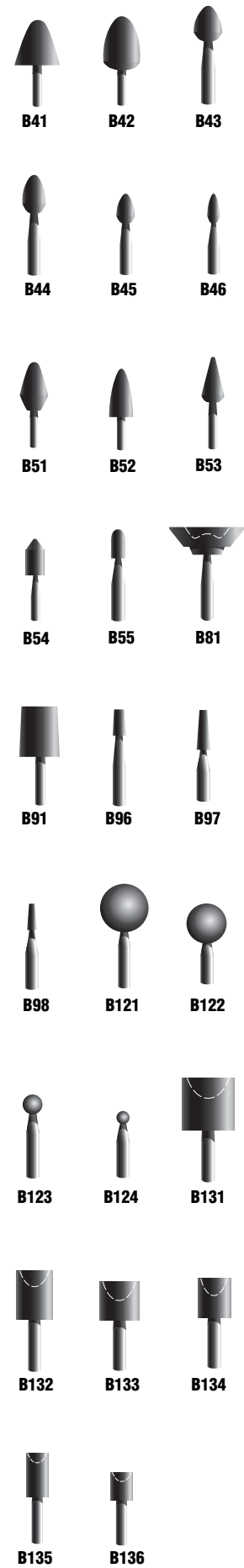



AVAILABILITY	TIER:	BEST	GOOD
	BRAND:	Norton	Norton
	TRADENAME:	QUANTUM	GEMINI
	ABRASIVE:	Ceramic Alumina	38A

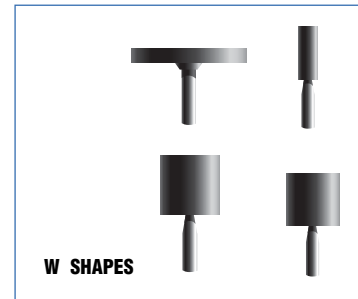

SHAPE	SIZE (D X T)	SPINDLE DIA. †	MAX. RPM*	MIN./STD. PKG.	SPEC	PART NO.	SPEC	PART NO.
VITRIFIED BOND MOUNTED POINTS – W SHAPES								
W144	1/8 x 1/4	1/8	92,460	5/25			38A60-P	61463624488
W145	1/8 x 3/8	1/8	84,190	5/25			38A60-P	61463624489
W146	1/8 x 1/2	1/8	76,820	5/25			38A60-P	61463624491
W152	3/16 x 1/4	1/8	82,070	5/25			38A60-P	61463624495
W153	3/16 x 3/8	1/8	73,880	5/25			38A60-P	61463624496
W154	3/16 x 1/2	1/8	66,580	5/25	3NQ80	69083149133	38A60-P	61463624497
W160	1/4 x 1/4	1/8	75,330	5/25			38A60-P	61463624501
W162	1/4 x 3/8	1/8	67,210	5/25			38A60-P	61463624503
W163	1/4 x 1/2	1/8	59,990	5/25			38A60-P	61463624504
W164	1/4 x 3/4	1/8	47,880	5/25	3NQ80	69083149135	38A60-P	61463624505
W170	5/16 x 1/2	1/8	54,860	5/25			38A60-P	61463624511
W175	3/8 x 3/8	1/8	57,530	5/25			38A60-P	61463624516
W176	3/8 x 1/2	1/8	50,460	5/25			38A60-P	61463624517
W177	3/8 x 3/4	1/8	38,640	5/25			38A60-P	61463624518
W185	1/2 x 1/2	1/8	42,750	5/25	3NQ80	69083149137	38A60-P	61463624525
W185	1/2 x 1/2	1/4	44,470	5/25			38A60-P	61463624526
W186	1/2 X 3/4	1/4	40,500	5/25			38A60-P	61463624528
W188	1/2 x 1-1/2	1/4	31,070	5/25			38A60-P	61463624530
W189	1/2 x 2	1/4	26,830	5/25	3NQ80	61463677683	38A60-P	61463624531
W196	5/8 x 1	1/4	34,670	5/25			38A60-P	61463624539
W200	3/4 x 1/8	1/8	50,930	5/25			38A60-P	61463624543
W200	3/4 x 1/8	1/8	50,930	5/25			38A90-Q	61463624544
W204	3/4 x 3/4	1/4	36,510	5/25			38A60-P	61463624549
W205	3/4 x 1	1/4	32,950	5/25			38A60-P	61463624550
W208	3/4 x 2	1/4	22,830	5/25	3NQ80	61463677684	38A60-P	61463624553
W215	1 x 1/8	1/8	38,200	5/25	3NQ80	69083149138	38A60-P	61463624560
W216	1 x 1/4	1/4	38,200	5/25			38A60-P	61463624562
W218	1 x 1/2	1/4	37,890	5/25			38A60-P	61463624564
W220	1 x 1	1/4	30,370	5/25	3NQ80	61463677685	38A60-P	61463624566
W221	1 x 1-1/2	1/4	24,490	5/25			38A60-P	61463624567
W222	1 x 2	1/4	20,250	5/25			38A60-P	61463624569
W230	1-1/4 x 1-1/4	1/4	25,200	5/25			38A60-P	61463624578
W235	1-1/2 x 1/4	1/4	25,460	5/25			38A60-P	61463624583
W236	1-1/2 x 1/2	1/4	25,460	5/25	3NQ80	61463677686	38A60-P	61463624585
W237	1-1/2 x 1	1/4	25,460	5/25			38A60-P	61463624587
W238	1-1/2 x 1-1/2	1/4	20,720	5/25			38A60-P	61463624588
W242	2 x 1	1/4	19,100	5/25			38A60-P	61463624592

† STANDARD SPINDLE SIZE IS 1/8" OR 1/4" x 1-1/2" * MAXIMUM OPERATING SPEED BASED ON 1/2" OVERHANG

TECHtip

- For best mounted point performance, always run the mounted point at the maximum allowable speed according to ANSI B7.1. Refer to the speed chart included in each shipment for proper operating speeds.
- Use "A" shapes for medium- to heavy-duty blending.
- Use "B" shapes for light deburring and finishing/polishing.
- Use "W" shapes for offhand and precision grinding of medium to heavy stock.
- Use 36 grit and coarser for rough grinding.
- Use 60 and 90 grits for imparting fine finishes or when grinding on narrow surfaces.

! It is the user's responsibility to refer to and comply with ANSI B7.1



50-Piece Mounted Point Kits

- Each kit contains 5 each of 10 of our best selling mounted point shapes and specifications
- The 1/4" spindle kit contains "A"-shaped points that are ideal for general maintenance and metalworking applications
- The 1/8" spindle kits contain "B"-shaped points for light deburring machine parts or finishing/polishing dies
- The "W"-shaped points in both these kits work well for precision grinding of medium to heavy stock

TIER:	BEST	GOOD
BRAND:	Norton	Norton
TRADENAME:	QUANTUM	GEMINI

SHAPE	SPINDLE DIA. †	MIN./STD. PKG.		PART NO.	PART NO.
MOUNTED POINT KITS					
Assorted	1/4	1	50 piece Premium Norton Quantum 1/4" Spindle Mounted Point Kit contains 5 each of A1, A5, A11, A21, A23, A26, A36, A39, W242 Norton Quantum and 5 W220 A80-HBF3	69083147810	
Assorted	1/8	1	50 piece Premium Norton Quantum 1/8" Spindle Mounted Point Kit contains 5 each of B42, B52, B97, B122, B131, W154, W164, W185, W215 Norton Quantum and W163 A80-HBF3	69083147806	
Assorted	1/4	1	50 piece 38A60-P 1/4" Spindle Gemini Mounted Point Kit contains 5 each of A1, A5, A11, A21, A23, A26, A36, A39, W242 Gemini and 5 W220 A80-HBF3		69083147789
Assorted	1/8	1	50 piece 38A60-P 1/8" Spindle Gemini Mounted Point Kit contains 5 each of B42, B52, B97, B122, B131, W154, W164, W185, W215 Gemini and W163 A80-HBF3		69083147669

† STANDARD SPINDLE SIZE IS 1/8" OR 1/4" x 1-1/2"





CATEGORY DEFINITION

Since 1823, Norton has been the leading supplier of conventional and diamond benchstones, waterstones, sharpening systems, files, slips and specialty stones for industrial, commercial and DIY sharpening applications. Our comprehensive line of sharpening and finishing products is the industry's broadest line with premier performance and quality.

- APPLICATIONS: Deburring, dimensioning, sharpening, honing
 GRIT RANGE: Coarse, Medium, Fine, Extra Fine, Ultra Fine
 ABRASIVE TYPES: Aluminum Oxide, Silicon Carbide, Arkansas, Diamond

APPLICATION-TO-PRODUCT RECOMMENDATION GUIDE

Benchstones

	Coarse/Medium Sharpening	Fine Stoning	Finish Honing
Chip Breakers	–	Fine Crystolon Benchstone	–
Draw Knives	Coarse Crystolon Benchstone	Fine India Benchstone	Hard Arkansas Benchstone
Scrapers	Coarse Crystolon Benchstone	Fine India Benchstone	Hard Arkansas Benchstone
Chisels (Wood)	Coarse Crystolon Benchstone 1000 Waterstone	Fine India Benchstone 4000 Waterstone	Hard Arkansas Benchstone 8000 Waterstone
Plane Blades	Coarse Crystolon Benchstone 1000 Waterstone	Fine India Benchstone 4000 Waterstone	Hard Arkansas Benchstone 8000 Waterstone

Slips

	Coarse/Medium Sharpening	Fine Stoning
Milling Cutter	Medium India Round Edge Slip	Fine India Round Edge Slip
Carbide Tools		Fine Crystolon Slip for Carbide Tools

Abrasive Files

	Coarse/Medium Sharpening	Fine Stoning	Finish Honing
Form Cutter	Coarse or Medium India Knife Blade	Fine India Knife Blade	–
Keyways	Coarse or Medium India Square File	Fine India Square File	–
Lathe Bits	Medium India Square File	Fine India Square File	–
Radius Tools	Medium India Round File	Fine India Round File	–
Reamers	Medium India Reamer Stone	Fine India Reamer Stone	–
Router Bits	–	Fine India Square File	–
Saws	Coarse India Triangular File	Fine India Tapered Triangular File	–
Center Punches	Medium India Triangular File	Fine India Triangular File	–
Magnetic Chucks	Medium Crystolon Round File	Fine India Round File	–
Molding Cutters*	Coarse or Medium India File	Fine India File	–
Countersinks	Coarse India Triangular File	Fine India Triangular File	Hard Arkansas Triangular File
Tap Threads	–	Fine India Triangular File	–

* SELECT SHAPE TO FIT CONFIGURATION



Relative Sharpening Comparisons for Norton Products

CRYSTOLON (SILICON CARBIDE) INDIA (ALUMINUM OXIDE)	ARKANSAS (SOFT, HARD TRANSLUCENT)	DIAMOND STONES	WATERSTONES			DIAMOND COMPOUND
			JIS (JAPAN)	CAMI (USA)	FEPA (EUROPE)	
					P100	141
Coarse Crystolon					P120	127
				120		116
Coarse India					P150	97
				150		93
Medium Crystolon				180	P180	78
		Extra Coarse Diamond (220)	Norton 220		P220	65
				220		60
					P240	58
Medium India				240		53.5
					P280	52.5
						50
					P320	46
Fine Crystolon						45
		Coarse Diamond (325)		280		43
					P360	40.5
			360	320		36
Fine India					P400	35
				360		29
					P600	25.8
				400		23
	Soft Arkansas	Fine Diamond (600)	600		P800	22
						20
			800	600	P1200	16
			Norton 1000	700		14
				800	P1500	12.6
			1200			11
					P2000	10.3
			1500	1000		9.2
						9
				1500	P2500	8.4
						7.5
	Hard Translucent Arkansas		Norton 4000	2000		6
						5
			Norton 8000			3
						1.2
						1
			15000			0.5



Benchstone Display

- Part No. 66253096034
- Pre-loaded, full-color Benchstone Display with 12 Crystolon (silicon carbide) benchstones, anniversary boxed.



FEATURED PRODUCTS

Benchstones



SINGLE GRIT ABRASIVE BENCHSTONES BETTER CHOICE FOR EDGE SHAPING AND HONING

FEATURES

- Crystolon – Premium silicon carbide abrasive
- India – Smooth cutting aluminum oxide abrasive; our best product for a fine finish
- Arkansas – Natural premium Novaculite quarried in Arkansas and available in Soft or Hard Translucent

BENEFITS

- Fast cutting stone; ideal for general sharpening of cutting tools
- Fast stock removal for quick edge shaping with minimal loading
- Long lasting cutting edge
- The choice of artisans, craftsmen and mechanics
- Ideal for clean deburring, generating keen edges and quality finishes
- Sharpest possible razor edges
- Near mirror finishes
- Use for finer honing after India stone

AVAILABILITY

TIER:

BETTER

SIZE (L X W X H)	QTY./PKG.	QTY./CASE	SPEC.	PRODUCT NO.	PART NO.
SINGLE GRIT BENCHSTONES – CRYSTOLON (SILICON CARBIDE)					
4 x 1 x 1/4	1	5	Coarse	CJB14	61463685470
			Medium	MJB14	61463685465
			Fine	FJB14	61463685460
4 x 1 x 1/2	1	5	Coarse	CJB24	61463685485
			Medium	MJB24	61463685480
			Fine	FJB24	61463685475
5 x 2 x 5/8	1	5	Medium	MJB35	61463685495
			Fine	FJB35	61463685490
6 x 2 x 1	1	5	Coarse	CJB6	61463685510
			Medium	MJB6	61463685505
			Fine	FJB6	61463685500
8 x 2 x 1	1	5	Coarse	CJB8	61463685525
			Medium	MJB8	61463685520
			Fine	FJB8	61463685515
SINGLE GRIT BENCHSTONES – ARKANSAS SOFT ARKANSAS					
4 x 2 x 3/4-1	1	5	Extra Fine	SB4	61463685670
6 x 2 x 3/4-1	1	5	Extra Fine	SB6	61463685675
8 x 2 x 3/4-1	1	5	Extra Fine	SB8	61463685680

AVAILABILITY

TIER:

BETTER

SIZE (L X W X H)	QTY./PKG.	QTY./CASE	SPEC.	PRODUCT NO.	PART NO.
SINGLE GRIT BENCHSTONES – INDIA (ALUMINUM OXIDE)					
4 x 1 x 1/4	1	5	Coarse	CB14	61463685580
			Medium	MB14	61463685575
			Fine	FB14	61463685570
4 x 1 x 1/2	1	5	Coarse	CB24	61463685595
			Medium	MB24	61463685590
			Fine	FB24	61463685585
5 x 2 x 5/8	1	5	Medium	MB35	61463685605
			Fine	FB35	61463685600
6 x 2 x 1	1	5	Coarse	CB6	61463685620
			Medium	MB6	61463685615
			Fine	FB6	61463685610
8 x 2 x 1	1	5	Coarse	CB8	61463685635
			Medium	MB8	61463685630
			Fine	FB8	61463685625
SINGLE GRIT BENCHSTONES – ARKANSAS HARD TRANSLUCENT					
4 x 2 x 3/4-1	1	5	Ultra Fine	HB4	61463685655
6 x 2 x 3/4-1	1	5	Ultra Fine	HB6	61463685660
8 x 2 x 3/4-1	1	5	Ultra Fine	HB8	61463685665



PRECISION BENCHSTONES BETTER CHOICE FOR SHARPENING TOOLS AND KNIVES

FEATURES AND APPLICATIONS

- Jewelers' Benchstones – These stones are excellent for sharpening the fine, precision cutting tools used by jewelers, engravers and artisans.
- Penknife Precision Benchstones – Ideal for sharpening cutting tools, laboratory blades, surgical instruments, engravers' and die makers' tools, and pocket knives to the keenest edge.

AVAILABILITY

TIER:

BETTER

SIZE (L X W X H)	QTY./PKG.	QTY./CASE	SPEC.	PRODUCT NO.	PART NO.
PRECISION BENCHSTONES – JEWELERS'					
4 x 2 x 3/8	1	5	Ultra Fine – Hard Translucent Arkansas	HB24	61463687525
6 x 2 x 3/8	1	5	Ultra Fine – Hard Translucent Arkansas	HB26	61463687530
PRECISION BENCHSTONES – PENKNIFE					
3 x 1 x 3/8	5	10	Ultra Fine – Soft Arkansas	SB13	61463687560
			Ultra Fine – Hard Translucent Arkansas	HB13	61463687550
4 x 1 x 3/8	5	10	Ultra Fine – Soft Arkansas	SB14	61463687565
			Ultra Fine – Hard Translucent Arkansas	HB14	61463687555



Benchstones CONTINUED



COMBINATION GRIT ABRASIVE BENCHSTONES

BETTER CHOICE FOR ECONOMICAL SOLUTION FOR GENERAL SHARPENING AND FINISHING WITH ONE STONE

FEATURES AND APPLICATIONS

Crystolon Combination

Coarse and fine grit sharp-cutting silicon carbide abrasive surfaces for general sharpening (to moderate tolerances) when the speed of sharpening is more important than the fineness of the cutting edges. Gray in color.

India Combination

Coarse and fine grit aluminum oxide abrasive surfaces produce strong, keen, long-lasting edges on quality tools. Orange/brown in color.

Crystolon/India Combination

Fast-sharpening, medium grit silicon carbide (Crystolon) and fine aluminum oxide (India) abrasive surfaces for keen, long-lasting edges on quality tools. Crystolon side is dark gray in color, India side is orange.

Giant Combination Stones

11-1/2" and 12" bench oil stones are used to sharpen large edge tools with long sweeping strokes.

AVAILABILITY

TIER: **BETTER**

SIZE (L X W X H)	QTY./ PKG.	QTY./ CASE	SPEC.	PRODUCT NO.	PART NO.
COMBINATION GRIT BENCHSTONES – CRYSTOLON (SILICON CARBIDE)					
4 x 1 Round	1	5	Coarse/Fine	JB64	61463685435
4 x 1-3/4 x 5/8	1	5	Coarse/Fine	JB134	61463685440
5 x 2 x 3/4	1	5	Coarse/Fine	JB45	61463685445
6 x 2 x 1	1	5	Coarse/Fine with Anniversary Box	JB6	61463685450
8 x 2 x 1	1	5	Coarse/Fine with Anniversary Box	JB8	61463685455
11-1/2 x 2-1/2 x 1	1	2	Coarse/Fine	JUM3	61463685840
12 x 2-1/2 x 1-1/2	1	2	Coarse/Fine	JUM4	61463685855
COMBINATION GRIT BENCHSTONES – INDIA (ALUMINUM OXIDE)					
4 x 1 Round	1	5	Coarse/Fine	IB64	61463685545
4 x 1-3/4 x 5/8	1	5	Coarse/Fine	IB134	61463685550
5 x 2 x 3/4	1	5	Coarse/Fine	IB45	61463685555
6 x 2 x 1	1	5	Coarse/Fine with Anniversary Box	IB6	61463685560
8 x 2 x 1	1	5	Coarse/Fine with Anniversary Box	IB8	61463685565
11-1/2 x 2-1/2 x 1	1	2	Coarse/Fine	IM2	61463685851
COMBINATION GRIT BENCHSTONES – CRYSTOLON/INDIA					
6 x 2 x 1	1	5	Medium/Fine	IC6	61463685643
11-1/2 x 2 x 1	1	2	Medium/Fine	IC11	61463687239
OIL STONE INSTRUCTIONAL DVD					
N/A	1	1	Oil Stone DVD		07660787945

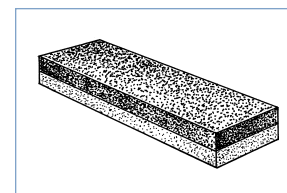

APPLICATION-TO-PRODUCT RECOMMENDATION GUIDE

	FAST CUT STOCK REMOVAL	INITIAL SHARPENING	FINAL SHARPENING	HONING	SHARPEST EDGE
Grit Size	Coarse	Medium	Fine	Extra Fine	Ultra Fine
Abrasive	Crystolon	Crystolon	India	Soft Arkansas	Hard Arkansas
Product/Color	Grey	Grey	Orange	Milky White	Translucent



Instructional DVD Offering

Waterstone: 07660787944
Oil Stone: 07660787945

Ideal for sales training and end-user self-study. Learn to efficiently use these sharpening products to maintain tools at peak performance and prolong their life – to make all your sharpening, honing, etc. application easier.



Waterstones

Waterstones are synthetic stones designed to be softer than oil stones. These softer grade stones are used with water as the lubricant (versus oil) to develop a fast cutting slurry. The Norton Waterstone system was designed in a carefully planned sequence to create sharpening efficiency. You get the level of abrasiveness you need at each stage, without wasting time trying to sharpen your tools on a grit that is too fine, too soon.

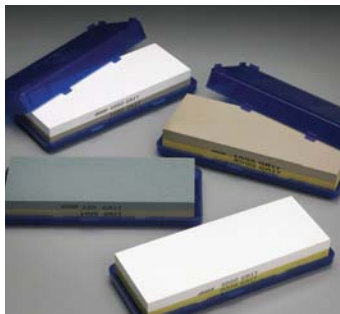

WATERSTONES

BETTER CHOICE FOR PRODUCING SUPERIOR EDGES FOR PLANES AND STRAIGHT CHISELS

FEATURES

- System of four synthetic “Japanese-type” stones designed to work together, with water
- Softer than traditional oilstones – providing lapping action
- Color-coded by grit

BENEFITS

- Fast sharpening, fine finish
- Superb results with low pressure
- Easy to differentiate grit



PREP STONE

BETTER CHOICE FOR RAISING SLURRY

FEATURES

- This synthetic stone raises the slurry

BENEFITS

- Speeds up the slurry-making process needed to cut and polish with waterstones

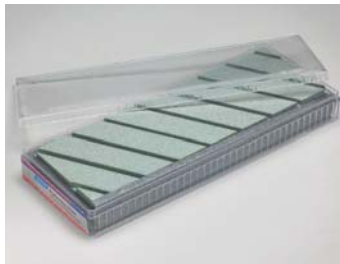

FLATTENING STONE

BETTER CHOICE FOR PRODUCING FLAT RESULTS ON WATERSTONES

FEATURES

- Coarse grit silicon carbide stone
- Diagonal grooves
- Superbly flat with hard bond

BENEFITS

- Promotes maximum cutting for all grit sizes of waterstones
- Provide swarf removal
- Produces extremely flat results on all waterstones

AVAILABILITY

SIZE (L X W X H) QTY./PKG. QTY./CASE SPEC.

WATERSTONES – SINGLE GRIT (BULK-PACKED)

SIZE (L X W X H)	QTY./PKG.	QTY./CASE	SPEC.
8 x 3 x 1	1	5	220 1000 4000 8000
Set	1	1	4 Stones: 220, 1000, 4000, 8000 Grit

WATERSTONES – COMBINATION GRIT (BULK-PACKED)

SIZE (L X W X H)	QTY./PKG.	QTY./CASE	SPEC.
8 x 3 x 1	1	5	220 / 1000 1000 / 4000 1000 / 8000 4000 / 8000

PREP STONE

SIZE (L X W X H)	QTY./PKG.	QTY./CASE	SPEC.
20mm x 20mm x 3"	1	5	Aluminum Oxide

FLATTENING STONE

SIZE (L X W X H)	QTY./PKG.	QTY./CASE	SPEC.
9 x 3 x 3/4	1	5	Silicon Carbide

WATERSTONE INSTRUCTIONAL DVD

SIZE (L X W X H)	QTY./PKG.	QTY./CASE	SPEC.
N/A	1	1	Waterstone DVD

TIER:

BETTER

PART NO.

61463689505
61463689506
61463689507
61463689508
61463624334

61463624335
61463624450
69936655039
61463624336

66243439361

69936687444

07660787944



Instructional DVD Offering

Waterstone: 07660787944

Oil Stone: 07660787945

Ideal for sales training and end-user self-study. Learn to efficiently use these sharpening products to maintain tools at peak performance and prolong their life – to make all your sharpening, honing, etc. application easier.

TECHtip

MAXIMIZING WATERSTONE PERFORMANCE

- Wet waterstone
- Rub evenly with the prep stone to create slurry
- Evening off the high spots will make for less-frequent flattening of the waterstones
- Waterstones wear concave with use; periodically flatten with flattening stone



Diamond Benchstones

Made in the USA, these benchstones have unique stackable non-skid rubber feet designed to keep the diamond plate steady while you sharpen, and efficiently stacked for space-saving storage when not in use. Our simple grit-size color-coding makes them easy to differentiate.

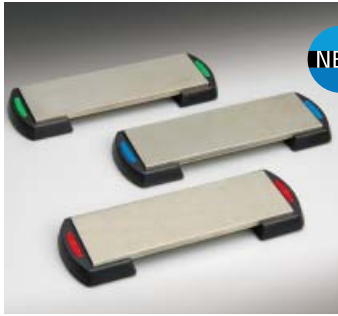

NEW

STACKABLE DIAMOND BENCHSTONES

BETTER CHOICE FOR PRODUCING SUPERIOR EDGES FOR PLANES AND STRAIGHT CHISELS

FEATURES

- Made in the USA
- Flat, diamond surface plated onto a nickel-coated steel bar precision ground to a tolerance of .001"
- Even diamond distribution; continuous diamond sharpening surface
- Available in 3 grit sizes: 220 (red), 325 (blue), 600 (green), and 2 sizes: 6" and 8"
- Color-coded tabs on stones and packaging
- Stackable; the stones firmly stack on top of each other
- Non-skid rubber base

BENEFITS

- Quality industrial diamonds and workmanship
- Fast, even blade and tool edge sharpening
- Easily lubricated with water, but oil may be used
- Excellent sharpening performance across entire surface of stone
- Quicker sharpening than conventional interrupted-surface diamond stones
- Pointed tools will not snag, as on interrupted-surface diamond stones
- Ideal for all your large and small tool sharpening and finishing needs
- Easy identification of grit sizes for use and displaying
- Easy, small-profile storage
- Stays in place while sharpening for smoother, efficient sharpening

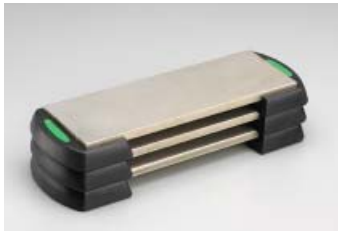

AVAILABILITY

SIZE WITH RUBBER FEET (L X W X H)	QTY./ PKG.	QTY./ CASE	SPEC.	TIER: BETTER	PART NO.
STACKABLE DIAMOND BENCHSTONES					
6 x 2 x 1/4	1	5	D220		66253268082
6 x 2 x 1/4	1	5	D325		66253268081
6 x 2 x 1/4*	1	5	D600		66253268080
8 x 2 x 1/4	1	5	D220		66253268087
8 x 2 x 1/4	1	5	D325		66253268086
8 x 2 x 1/4	1	5	D600		66253268083



6" STONES COME RETAIL PACKAGED

Sharpening Stone Oil



SHARPENING STONE OIL

BETTER CHOICE FOR IMPROVING SHARPENING STONE PERFORMANCE

FEATURES

- Norton oil is a highly refined lubricating oil
- Meets U.S. Pharmacopoeia standards for mineral oil purity

BENEFITS

- Specifically formulated for sharpening stone use
- Equally ideal for all lubricating jobs
- It will not load or "gum-up" sharpening stones
- May be used around food preparation operations

AVAILABILITY

SIZE	QTY./ PKG.	QTY./ CASE	SPEC.	TIER: BETTER	PRODUCT NO.	PART NO.
SHARPENING STONE OIL						
4-1/2 oz.	1	20	Oil		XB1	61463687760
1 Pint	1	20	Oil		XB5	61463687770
1 Quart	1	5	Oil		XB2	61463687775

TECHtip

- All oil stones are porous in nature; oil is required to keep the pores open and working efficiently
- Use Norton oil to optimize the performance of Crystolon, India and Arkansas stones.
- While sharpening knives, blades and tools, be careful to keep fingers away from sharp edges.



Sharpening Systems

Tri-Stone Systems

The base of the tri-stone system acts as an oil reservoir permitting continuous submersion of the unused stones, keeping them clean and saturated, ready for immediate use and years of utility. Rotating the handle brings the desired stone into position for sharpening. All offer a range of replacement stones to replace worn or damaged stones, or substitute different specifications to customize the system.



IM313 MULTI-OILSTONE SHARPENING SYSTEM BETTER CHOICE FOR LARGE, STRAIGHT-EDGED TOOL SHARPENING

FEATURES AND BENEFITS

Considered by many to be the ultimate sharpening system, the IM313 contains three oil stones. The 11-1/2" stone length permits long, sweeping strokes for faster and more precise sharpening and honing of all large, wider straight-edged tools. The heavy base has a non-skid bottom. A pint of Norton oil, plastic angle guide, and reservoir unit are included with each IM313 system. For general sharpening – coarse Crystolon quickly restores worn edges; medium Crystolon produces the average edge needed for most tools; and fine India stone hones for a sharper edge.



IM200 PROFESSIONAL SHARPENING SYSTEM BETTER CHOICE FOR A VERSATILE, MULTI-SIZE TOOL AND KNIFE SHARPENER

FEATURES AND BENEFITS

The smaller 8" stone IM200 system provides the same quality sharpening features as the IM313 – making it the perfect choice for small restaurants and home DIYers. The system contains 4-1/2 oz. of lubricating oil, plastic angle guide, and the reservoir unit. For general sharpening – coarse Crystolon quickly restores worn edges; medium Crystolon produces the average edge needed for most tools; and fine India stone hones for a sharper edge.



IM100 3-IN-1 TOOL AND KNIFE SHARPENING SYSTEM BETTER CHOICE FOR SMALL STRAIGHT-EDGED TOOL SHARPENING

FEATURES AND BENEFITS

The smallest system, designed for general sharpening, the IM100 is an affordable choice for small knives, cutlery, and woodworking tools. 4-1/2 oz. of lubricating oil and a reservoir unit complete the system. For general sharpening – coarse Crystolon quickly restores worn edges; medium Crystolon produces the average edge needed for most tools; and fine India stone hones for a sharper edge.

Portable Sharpening Systems



IM83 PORTABLE SHARPENING STONE SYSTEM BETTER CHOICE FOR ALL SHARPENING ENTHUSIAST WHO WANT TO CARRY THEIR SYSTEM WITH THEM

FEATURES AND BENEFITS

These unique "tool-box" portable systems allow you to sharpen tools wherever needed. Sturdy metal latches secure the cover and storage case – where small tools can be housed. The IM83 is designed like all our other sharpening systems; the stones can be replaced to customize the unit to individual requirements. These systems are ideal for industrial toolrooms, restaurants, knife manufacturers as well as home DIYers and sportsmen.

Both IM83 systems include 3 sharpening stones, an instructional DVD in the base, and a reservoir carrying case. The oil stone system also includes 4-1/2 oz. oil.

IM83-W Portable Waterstone System – Tool Repair to Fine Finishes

This portable sharpening system is equipped with a carefully engineered sequence of waterstones for clean, efficient sharpening. The waterstones can easily be maintained with the flattening stone provided.

IM83-O Portable Oil Stone System – Straight-Edged Tool Sharpening

The coarse silicon carbide (Crystolon) stone in this system repairs damaged edges quickly; the medium aluminum oxide (India) stone imparts a durable, smooth cutting edge; and the fine aluminum oxide (India) stone provides the final sharpening and polishing stage.





Sharpening Systems CONTINUED

AVAILABILITY

SIZE	QTY./ PKG.	QTY./ CASE	SPEC.	TIER: BETTER	
				PRODUCT NO.	PART NO.
IM313 MULTI-OILSTONE SHARPENING SYSTEM					
11-1/2 x 2-1/2 x 1/2	1	1	1 Coarse Crystolon, 1 Medium Crystolon, 1 Fine India, 1 Pint Oil, Angle Guide, Reservoir Unit	IM313	61463685960
IM200 PROFESSIONAL SHARPENING SYSTEM					
8 x 2 x 3/8	1	1	1 Coarse Crystolon, 1 Medium Crystolon, 1 Fine India, 4-1/2 oz. Oil, Angle Guide, Reservoir Unit	IM200	61463691260
IM100 3-IN-1 TOOL AND KNIFE SHARPENING SYSTEM					
6 x 2 x 1/2	1	5	1 Coarse Crystolon, 1 Medium Crystolon, 1 Fine India, 4-1/2 oz. Oil, Reservoir Unit	IM100	61463685356
IM83 PORTABLE SYSTEMS					
8 x 3 x 1/2	1	1	Oilstones: 1 Coarse Crystolon, 1 Medium India, 1 Fine India, 4-1/2 oz. Oil, Instructional DVD in Base, Reservoir Carrying Case	IM83-O	66243582823
8 x 3 x 1	1	1	Waterstones: 1 ea. of 1000, 4000, 8000 Grit, 1 Flattening Stone, Instructional DVD in Base, Reservoir Carrying Case	IM83-W	66243582825

SEE WWW.NORTONSTONES.COM OR YOUR NORTON REPRESENTATIVE FOR SHARPENING SYSTEM REPLACEMENT STONES – WHICH MAY BE USED AS REPLACEMENTS OR TO CUSTOMIZE YOUR SYSTEM

Abrasive Files

Norton abrasive files hold their shape while imparting the finest, most uniform finish on precision machine parts and in tool and die making. They are ideal for any deburring, chamfering or radiusing job, or for filing delicate parts. Select the file shape that matches the contour of the surface being stoned.



ABRASIVE FILES

BETTER CHOICE FOR ANY DEBURRING, CHAMFERING OR RADIUSING JOB, OR FOR FILING DELICATE PARTS

FEATURES AND APPLICATIONS

Crystolon Files – Fast-acting silicon carbide products, Crystolon files are designed for use where moderate tolerances are acceptable, and speed of sharpening is more important than fineness.

India Files – India files are ideal when close tolerance, and strong, keen, long lasting edges are needed.

Hard Translucent Arkansas Files – Hard Arkansas has an ultra fine grit that produces the finest edge possible while maintaining tolerances unequalled by any other abrasive file. It will also produce a highly polished finish.

Square Abrasive Files

Square File applications range from dimensioning keyways to maintain fit, stoning faces on router bits, touching-up edges of reamer teeth, and lapping/honing to close tolerances to produce the finest edge on precision instruments, die work and delicate tools.



AVAILABILITY

SIZE (L X W X H)	QTY./ PKG.	QTY./ CASE	SPEC.	TIER: BETTER	
				PRODUCT NO.	PART NO.
SQUARE ABRASIVE FILES – CRYSTOLON (SILICON CARBIDE)					
4 x 3/8	5	20	Fine	FJF34	61463686030
4 x 1/2	5	20	Medium	MJF44	61463686045
			Fine	FJF44	61463686040
6 x 1	5	20	Medium	MJF76	61463625039
SQUARE ABRASIVE FILES – HARD TRANSLUCENT ARKANSAS					
3 x 1/4	5	10	Ultra Fine	HF13	61463686590
3 x 3/8	5	10	Ultra Fine	HF33	61463686595
3 x 1/2	5	10	Ultra Fine	HF43	61463686600

ALL SQUARE FILES ARE BULK PACKED

AVAILABILITY

SIZE (L X W X H)	QTY./ PKG.	QTY./ CASE	SPEC.	TIER: BETTER	
				PRODUCT NO.	PART NO.
SQUARE ABRASIVE FILES – INDIA (ALUMINUM OXIDE)					
4 x 1/4	5	20	Coarse	CF14	61463686075
			Medium	MF14	61463686070
			Fine	FF14	61463686065
4 x 3/8	5	20	Coarse	CF34	61463686090
			Medium	MF34	61463686085
			Fine	FF34	61463686080
4 x 1/2	5	20	Coarse	CF44	61463686105
			Medium	MF44	61463686100
			Fine	FF44	61463686095
6 x 1/2	5	20	Coarse	CF46	61463686120
			Medium	MF46	61463686115
			Fine	FF46	61463686110
6 x 5/8	5	20	Medium	MF56	61463686130
			Fine	FF56	61463686125
6 x 3/4	5	20	Coarse	CF66	61463686150
			Medium	MF66	61463686145
			Fine	FF66	61463686140
6 x 1	5	20	Coarse	CF76	61463686165
			Medium	MF76	61463686160
			Fine	FF76	61463686155



Abrasive Files CONTINUED

Triangular Abrasive Files

Triangular Files are used for a variety of deburring, chamfering and radiusing applications including cleaning tap threads, stoning cutting surfaces of milling cutters, lapping honing tools, dies and molds, and putting precision points on center punches.

The India line also offers Tapered Triangles...used by mechanics and tool and die makers to impart the correct edge in the least time.



AVAILABILITY

TIER: BETTER

SIZE (L X W X H)	QTY./ PKG.	QTY./ CASE	SPEC.	PRODUCT NO.	PART NO.
TRIANGULAR ABRASIVE FILES – CRYSTOLON (SILICON CARBIDE)					
4 x 1/4	5	20	Fine	FJF114	61463686185
4 x 1/2	5	20	Fine	FJF144	61463686205
TRIANGULAR ABRASIVE FILES – HARD TRANSLUCENT ARKANSAS					
3 x 1/4	5	10	Ultra Fine	HF113	61463686620
3 x 3/8	5	10	Ultra Fine	HF133	61463686625
3 x 1/2	5	10	Ultra Fine	HF143	61463686630

ALL TRIANGULAR FILES ARE BULK PACKED

Round Abrasive Files

Half Round Files offer both a round and a flat surface for imparting a fine finish on precision machine parts, tools and dies.

Round Files are ideal for deburring, chamfering, radiusing, lapping, honing, cleaning radius tools to a burr-free edge, and dimensioning compound curves on templates.

Round Pointed Files are ideally suited for engravers and die sinkers for stoning difficult recesses on instruments and die tools.

Round Tapered Files are used by craftsmen, woodworkers, and die makers as their unique shape imparts the correct edge quickly.

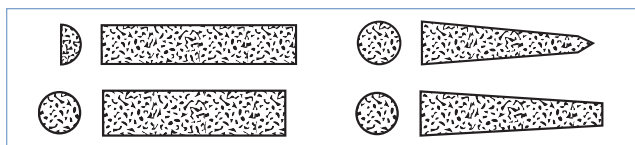

AVAILABILITY

TIER: BETTER

SIZE (L X W X H)	QTY./ PKG.	QTY./ CASE	SPEC.	PRODUCT NO.	PART NO.
HALF ROUND ABRASIVE FILES – INDIA (ALUMINUM OXIDE)					
4 x 1/4	5	20	Medium	MF314	61463686355
			Fine	FF314	61463686350
4 x 3/8	5	20	Medium	MF334	61463686385
			Fine	FF334	61463686380
4 x 1/2	5	20	Coarse	CF344	61463686405
			Medium	MF344	61463686400
			Fine	FF344	61463686395
ROUND ABRASIVE FILES – CRYSTOLON (SILICON CARBIDE)					
4 x 1/4	5	20	Medium	MJF214	61463686430
			Fine	FJF214	61463686425
4 x 3/8	5	20	Medium	MJF234	61463686440

ALL HALF-ROUND AND ROUND FILES ARE BULK PACKED

AVAILABILITY

TIER: BETTER

SIZE (L X W X H)	QTY./ PKG.	QTY./ CASE	SPEC.	PRODUCT NO.	PART NO.
TRIANGULAR ABRASIVE FILES – INDIA (ALUMINUM OXIDE)					
4 x 1/4	5	20	Coarse	CF114	61463686240
			Medium	MF114	61463686235
			Fine	FF114	61463686230
4 x 3/8	5	20	Coarse	CF134	61463686255
			Medium	MF134	61463686250
			Fine	FF134	61463686245
4 x 1/2	5	20	Coarse	CF144	61463686270
			Medium	MF144	61463686265
			Fine	FF144	61463686260
6 x 1/2	5	20	Coarse	CF146	61463686285
			Medium	MF146	61463686280
			Fine	FF146	61463686275
6 x 5/8	5	20	Medium	MF156	61463686295
			Fine	FF156	61463686290
6 x 3/4	5	20	Medium	MF166	61463686310
			Fine	FF166	61463686305
6 x 1	5	20	Medium	MF176	61463686325
			Fine	FF176	61463686320
TRIANGULAR TAPERED ABRASIVE FILES – INDIA (ALUMINUM OXIDE)					
4 x 1/2 x 1/4	5	20	Medium	MF544	61463686685
			Fine	FF544	61463686680

AVAILABILITY

TIER: BETTER

SIZE (L X W X H)	QTY./ PKG.	QTY./ CASE	SPEC.	PRODUCT NO.	PART NO.
ROUND ABRASIVE FILES – INDIA (ALUMINUM OXIDE)					
4 x 1/4	5	20	Coarse	CF214	61463686480
			Medium	MF214	61463686475
			Fine	FF214	61463686470
4 x 3/8	5	20	Coarse	CF234	61463686495
			Medium	MF234	61463686490
			Fine	FF234	61463686485
4 x 1/2	5	20	Coarse	CF244	61463686510
			Medium	MF244	61463686505
			Fine	FF244	61463686500
6 x 1/2	5	20	Coarse	CF246	61463686525
			Medium	MF246	61463686520
			Fine	FF246	61463686515
6 x 5/8	5	20	Medium	MF256	61463686535
6 x 3/4	5	20	Medium	MF266	61463686550
6 x 1	5	20	Medium	MF276	61463686565
ROUND ABRASIVE FILES – HARD TRANSLUCENT ARKANSAS					
3 x 1/4	5	10	Ultra Fine	HF813	61463686800
ROUND POINTED ABRASIVE FILES – INDIA (ALUMINUM OXIDE)					
3 x 5/16 Base	5	20	Coarse	CF723	61463686750
			Medium	MF723	61463686745
			Fine	FF723	61463686740
ROUND POINTED ABRASIVE FILES – HARD TRANSLUCENT ARKANSAS					
3 x 1/4 Base	5	10	Ultra Fine	HF863	61463686825
ROUND TAPERED ABRASIVE FILES – INDIA (ALUMINUM OXIDE)					
4 x 1/2 x 1/4	5	20	Coarse	CF644	61463686660
			Medium	MF644	61463686655
			Fine	FF644	61463686650



Abrasive Files CONTINUED

Diamond-shaped Abrasive Files

Diamond-shaped Files are precision sharpening favorites for cleaning acute angles in dies and molds, and for stoning geometric chasers and sewing machine feeds.



AVAILABILITY TIER: BETTER

SIZE (L X W X H)	QTY./ PKG.	QTY./ CASE	SPEC.	PRODUCT NO.	PART NO.
DIAMOND-SHAPED ABRASIVE FILES – INDIA (ALUMINUM OXIDE)					
4 x 9/16 x 3/16	5	20	Coarse	CT134	61463686720
			Medium	MT134	61463686715
			Fine	FT134	61463686710

DIAMOND-SHAPED ABRASIVE FILE – HARD TRANSLUCENT ARKANSAS					
3 x 1/2 x 3/16	5	10	Ultra Fine	HF843	61463686815

ALL DIAMOND-SHAPED FILES ARE BULK PACKED

Beveled Abrasive Files

Beveled Files are preferred by exacting artisans, jewelers, mechanics, and watchmakers for honing the finest of finishes. These extremely hard files provide years of service.



AVAILABILITY TIER: BETTER

SIZE (L X W X H)	QTY./ PKG.	QTY./ CASE	SPEC.	PRODUCT NO.	PART NO.
BEVELED ABRASIVE FILE – HARD TRANSLUCENT ARKANSAS					
3 x 3/8 x 1/8	5	10	Ultra Fine	HF833	61463686810

ALL BEVELED FILES ARE BULK PACKED

Flat Abrasive Files

The Flat File is the choice of mechanics, artisans and jewelers. This long lasting file produces the finest finishes.



AVAILABILITY TIER: BETTER

SIZE (L X W X H)	QTY./ PKG.	QTY./ CASE	SPEC.	PRODUCT NO.	PART NO.
FLAT ABRASIVE FILE – HARD TRANSLUCENT ARKANSAS					
3 x 3/8 x 1/8	5	10	Ultra Fine	HF823	61463686805

ALL FLAT FILES ARE BULK PACKED

Oval Abrasive Files

The Oval File's shape makes it ideal for finishing and honing recesses or curved edges of precision instruments.



AVAILABILITY TIER: BETTER

SIZE (L X W X H)	QTY./ PKG.	QTY./ CASE	SPEC.	PRODUCT NO.	PART NO.
OVAL ABRASIVE FILE – HARD TRANSLUCENT ARKANSAS					
3 x 1/2 x 3/16	5	10	Ultra Fine	HF853	61463686820

ALL OVAL FILES ARE BULK PACKED

Knife Blade Abrasive Files

Knife Blade Files are used by clock and watch makers to quickly sharpen, hone, and maintain the edges and points of cutting tools.

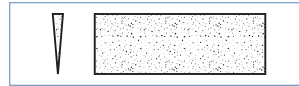

AVAILABILITY TIER: BETTER

SIZE (L X W X H)	QTY./ PKG.	QTY./ CASE	SPEC.	PRODUCT NO.	PART NO.
KNIFE BLADE ABRASIVE FILES – INDIA (ALUMINUM OXIDE)					
4 x 1 x 1/8 Back	5	20	Coarse	CF724	61463686780
			Medium	MF724	61463686775
			Fine	FF724	61463686770

KNIFE BLADE ABRASIVE FILE – HARD TRANSLUCENT ARKANSAS					
3 x 3/4 x 1/8	5	10	Ultra Fine	HF873	61463686830

ALL KNIFE BLADE FILES ARE BULK PACKED

Abrasive File Sets

Hard Translucent Arkansas File Set

This set provides a selection of our most popular square, triangular, round and knife blade files in ultra fine Hard Translucent Arkansas for honing and polishing a wide range of configurations.

Hard Translucent Arkansas-India File Set

This set contains an assortment of files for finishing, honing and polishing applications. It contains a selection of the most popular square, triangular, round and knife blade files in both fine grit India and ultra fine grit Hard Translucent Arkansas.

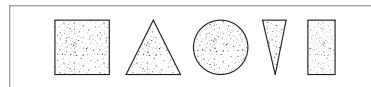

AVAILABILITY TIER: BETTER

SIZE (L X W X H)	QTY./ PKG.	QTY./ CASE	SPEC.	PRODUCT NO.	PART NO.
---------------------	---------------	---------------	-------	----------------	----------

FILE SET – HARD TRANSLUCENT ARKANSAS					
	1	5			61463686839
1 Each of Ultra Fine Hard Arkansas HF13, HF113, HF813, and HF873					

FILE SET – HARD TRANSLUCENT ARKANSAS AND INDIA					
	1	5			61463686840
1 Each of Ultra Fine Hard Arkansas HF13, HF43, HF113, HF813, HF873, and Fine India FF14, FF44, FF114, FF214, FF724					

See the “Norton Professional Sharpening Products and Dressing Sticks Catalog #200” on www.nortonstones.com to view the complete list and descriptions of our many sharpening products.



Abrasive Files CONTINUED

Engravers' Chuck & Points

Engravers' Points are the choice of professional die-makers for cleaning tight corners and recesses where close tolerances and accuracy are a must. The Engravers' Chuck is a knurled nickel-plated tool designed to hold the Engravers' Point.

AVAILABILITY

SIZE WITH RUBBER FEET (L X W X H)	QTY./ PKG.	QTY./ CASE	SPEC.	TIER: BETTER	
				PRODUCT NO.	PART NO.
ENGRAVERS' CHUCK					
Engravers' Chuck	5	10		XT1	61463687485
ENGRAVERS'S POINT – INDIA (ALUMINUM OXIDE)					
1 x 1/8 Point	5	20	Fine	FT11	61463687495
ENGRAVERS'S POINT – SOFT ARKANSAS					
1 x 1/8 Point	5	20	Extra Fine	AT11	61463687490

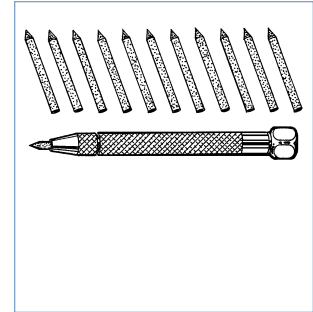

Silversmith Precision Files

These aluminum oxide precision-shaped stones are designed for use by silversmiths and mechanics for close tolerance lapping, touching-up instruments, and for cleaning tools and dies.

AVAILABILITY

SIZE WITH RUBBER FEET (L X W X H)	QTY./ PKG.	QTY./ CASE	SPEC.	TIER: BETTER	
				PRODUCT NO.	PART NO.
SILVERSMITH PRECISION FILES – INDIA (ALUMINUM OXIDE)					
4 x 5/16 x 3/16 x 5/16 x 1/16 - X	5	20	Medium	MF414	61463686855
			Fine	FF414	61463686850
4 x 3/8 x 3/16 x 1/8 x 1/16 - Y	5	20	Medium	MF424	61463686915
			Fine	FF424	61463686910
4 x 7/16 x 3/16 x 1/8	5	20	Fine	FF434	61463686940
4 x 1/2 x 1/16 - BB	5	20	Coarse	CF444	61463686965
			Medium	MF444	61463686960
			Fine	FF444	61463686955
4 x 1/2 x 1/4 x 5/16 x 1/8 - DD	5	20	Fine	FF464	61463686985
4 x 1/2 x 1/4 x 5/16 x 1/8 - EE	5	20	Medium	MF474	61463687005
			Fine	FF474	61463687000

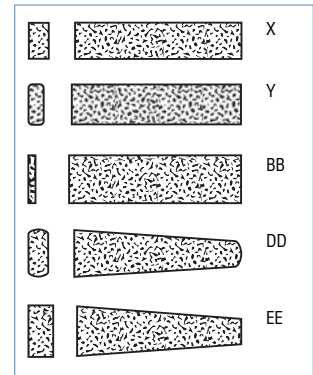

Pocket Stones



POCKET STONES

BETTER CHOICE FOR OUTDOOR ENTHUSIASTS

FEATURES AND BENEFITS

- Convenient and easily transported.
- Ideal for outdoor enthusiasts to sharpen scissors, knives, axes, etc.
- Available in a protective case.

AVAILABILITY

SIZE	QTY./ PKG.	QTY./ CASE	SPEC.	TIER: BETTER	
				PRODUCT NO.	PART NO.
POCKET STONE – INDIA SPORTSMAN					
3 x 1-1/2 x 1/2	1	50	Coarse/Fine	IBP34	61463690705
POCKET STONE – INDIA					
4 x 3/4 x 1/4	1	25	Fine	IBP4	61463624153
POCKET STONE WITH CASE – CRYSTOLON					
3 x 7/8 x 3/8 with Case	50		Fine	JP14	61463690703
FISH HOOK STONE WITH POUCH – CRYSTOLON HALF-ROUND					
3" x 1/2" with Pouch	50		Fine		61463624072



Abrasive Slips



ABRASIVE SLIPS

BETTER CHOICE FOR IMPARTING FINE, UNIFORM FINISHES

FEATURES AND BENEFITS

- Norton abrasive slips impart the finest, most uniform finishes on curved knives and tools, molders' knives, wood gouges, bead planers, and carbide-tipped tools. These fast-acting slips hold their shape and are long lasting.
- The Crystolon and India stones are designed for preliminary sharpening and the Norton Hard Translucent Arkansas stones are the choice for achieving the finest finish possible.

Carbide Tool Slips

Crystolon (silicon carbide) Slips are used to maintain the edge of carbide tools – keeping regrinding costs and time to an absolute minimum. Not oil-filled.



Round Edge Slips

Round Edge Slips are ideal for precision sharpening and honing of bead planers, curved knives and tools, molders' knives and wood gouges.



AVAILABILITY

TIER:

BETTER

SIZE	QTY./ PKG.	QTY./ CASE	SPEC.	PRODUCT NO.	PART NO.
CARBIDE TOOL SLIPS – CRYSTOLON (SILICON CARBIDE)					
3-1/2 x 3/4 x 1/2	5	20	Coarse	CJT63	61463687295
			Medium	MJT63	61463687290
			Fine	FJT63	61463687285
Set of Three Above	5	10	Coarse, Medium & Fine	J63	61463687300
ROUND EDGE SLIPS – CRYSTOLON (SILICON CARBIDE)					
4-1/2 x 1-3/4 x 1/4 x 1/16	5	10	Medium	MJS24	61463687080
			Fine	FJS24	61463687075
4-1/2 x 1-3/4 x 1/2 x 3/16	5	10	Coarse	CJS44	61463687100
			Medium	MJS44	61463687095
			Fine	FJS44	61463687090
6 x 2-1/4 x 3/4 x 3/8	5	10	Medium	MJS66	61463687110
			Fine	FJS66	61463687105
ROUND EDGE SLIPS – INDIA (ALUMINUM OXIDE)					
4 x 1 x 7/16 x 3/16	5	10	Medium	MS14	61463687140
			Fine	FS14	61463687135
4-1/2 x 1-3/4 x 1/4 x 1/16	5	10	Coarse	CS24	61463687155
			Medium	MS24	61463687150
			Fine	FS24	61463687145
4-1/2 x 1-3/4 x 3/8 x 1/8	5	10	Coarse	CS34	61463687170
			Medium	MS34	61463687165
			Fine	FS34	61463687160
4-1/2 x 1-3/4 x 1/2 x 3/16	5	10	Coarse	CS44	61463687185
			Medium	MS44	61463687180
			Fine	FS44	61463687175
5 x 1 x 5/16 x 3/32	5	10	Medium	MS15	61463687195
			Fine	FS15	61463687190
ROUND EDGE SLIPS – SOFT ARKANSAS					
4 x 1-3/4 x 3/8 x 1/8	5	10	Extra Fine	SS4	61463687055
ROUND EDGE SLIPS – HARD TRANSLUCENT ARKANSAS					
3 x 1-3/4 x 1/4 x 1/16	5	10	Ultra Fine	HS3	61463687040
4 x 1-1/4 x 1/4 x 1/8	5	10	Ultra Fine	HS14	61463687050
4 x 1-3/4 x 3/8 x 1/8	5	10	Ultra Fine	HS4	61463687045



Specialty Stones



SPECIALTY STONES

BETTER CHOICE FOR SPECIFIC SHARPENING OR DEBURRING APPLICATIONS

FEATURES AND BENEFITS

- Norton continues to offer specialty stones with optimum specifications and unique shapes that conform to, and quickly sharpen, specific tools

Specialty Stones for Machine Tools

Machine Knife Stone

Crystolon (silicon carbide) Machine Knife Stones offer both coarse and fine sides for sharpening and honing paper and cloth-cutting knives and planer knives on the machine. The groove around the middle of the stone protects fingers and provides a secure hold.

Reamer Stones

India (aluminum oxide) Reamer Stones are durable, fast-cutting stones designed for imparting a professional edge on reamers, taps, and rough rounders on shoe machine tools.

Boat Stones

Boat Stones are medium grit, medium grade stones that are easy to hold and use. Excellent for deburring and breaking sharp edges on dies, fixtures and machined parts, and for deburring grinder magnetic chucks.

AVAILABILITY

SIZE	QTY./ PKG.	QTY./ CASE	SPEC.	TIER: BETTER	
				PRODUCT NO.	PART NO.
MACHINE KNIFE STONE – CRYSTOLON (SILICON CARBIDE)					
4" Diam. x 1-1/2" Thick	1	5	Coarse/Fine	JB74	61463687570
REAMER STONES – INDIA (ALUMINUM OXIDE)					
4-1/2 x 1 x 5/16	5	10	Medium Fine	MT124 FT124	61463687420 61463687415
5 x 1 x 3/16	5	10	Medium Fine	MT125 FT125	61463687430 61463687425
6 x 1 x 1/4	5	10	Medium Fine	MT126 FT126	61463687440 61463687435
BOAT STONE – CRYSTOLON (SILICON CARBIDE)					
9 x 2-1/2 x 1-1/2	10	50	37C80-HV		61463610369
BOAT STONE – INDIA (ALUMINUM OXIDE)					
9 x 2-1/2 x 1-1/2	10	50	38A60-IVBE		61463610503

BOAT STONES ARE BULK PACKED

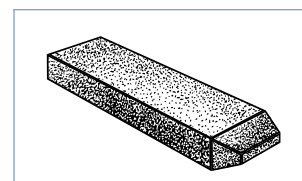
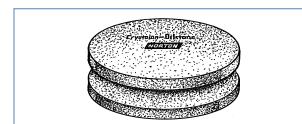

Large Specialty Stones

Tradesmen's Utility Stones

Used for sharpening trimming knives and as an abrasive file in many different industries. The JT910 does not have a handle, while the JT920 and JT930 have wooden handles.

Utility File

A long wedge-shaped stone with four flat sides designed for sharpening coarse cutting edges on cutting implements and edged garden tools. Wooden handles make them easy to use. They will outlast and out-sharpen metal files.

AVAILABILITY

SIZE	QTY./ PKG.	QTY./ CASE	SPEC.	TIER: BETTER	
				PRODUCT NO.	PART NO.
TRADESMEN'S UTILITY STONES – CRYSTOLON (SILICON CARBIDE)					
10 x 1-1/4 x 3/4 (Bulk-Packed)	5	10	Medium	JT910	61463687665
14-3/4 Overall (w/ Handle)	5	10	Coarse/Fine Medium	JT930 JT920	61463687675 61463687670
UTILITY FILE – CRYSTOLON (SILICON CARBIDE) (BULK-PACKED)					
14 Overall (w/ Handle)	5	10	Coarse	JD2	61463687750

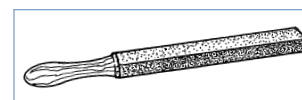



Retail Packaged Sharpening Products



AVAILABILITY

TIER: **BETTER**

BRAND Norton

SIZE (L X W X H)	SPECIFICATION	QTY/CASE	PART NO.
ABRASIVE SHARPENING STONES			
Axe & Hatchet Sharpener			
3 x 5/8 round	Coarse/Fine Crystolon	10	07660785316
Pocket Knife Sharpener			
3 x 7/8 x 3/8 with case	Medium Aluminum Oxide	5	07660787937
3 x 1-1/2 x 1/2 with case	Coarse/Fine Aluminum Oxide	5	07660787630
Economy Tool & Knife Bench Stone			
6 x 2 x 3/4	Coarse/Fine Aluminum Oxide	5	07660787933
8 x 2 x 3/4	Coarse/Fine Aluminum Oxide	10	07660787934
High Quality Tool & Knife Bench Stone			
6 x 2 x 3/4	Coarse/Fine Crystolon	5	07660787935
Chisel & Planer Blade Sharpener			
8 x 2 x 3/4	Coarse/Fine India	10	07660787936
Household Knife & Tool Sharpener			
7-1/2	Fine Crystolon	5	07660787939
Farm Tool Sharpener			
10 x 1-1/4 x 3/4	Coarse Crystolon	10	07660787730
Lawn & Garden Tool Sharpener			
9-1/2 x 1-3/8 x 1/2	Medium Crystolon	10	07660787938
Sharpening Stone Oil			
4-1/2 oz.	Oil	5	07660787940



Rolling Wheel Knife Sharpener

The compact, handheld **Rolling Wheel Knife Sharpener** has two slots, to sharpen each side of the blade. It has a built-in proper angle for sharpening. No lubricant needed.

SPECIFICATION	QTY/CASE.	PART NO.
Slotted, handheld	12	66253092616



Knife and Scissors Sharpener

The **Knife and Scissors Mechanical Sharpener** is a quick and portable tool for hundreds of sharpening applications.

SPECIFICATION	QTY/CASE.	PART NO.
Carbide	6	07660787520

Norton Professional Sharpening Products & Dressing Sticks

See the "Norton Professional Sharpening Products and Dressing Sticks Catalog #200" on www.nortonstones.com to view the complete list and descriptions of our many sharpening products.





CATEGORY DEFINITION

Hard silicon carbide rubbing bricks are used for heavy-duty applications such as rubbing floors, cleaning and scouring castings, rubbing down concrete, and removing mold marks.

APPLICATIONS:

Floor Rubbing Bricks – are used to rub down concrete and remove mold marks. These are designed to fit the chucks of common concrete floor grinding equipment. Reusable wooden wedges anchor the bricks to the equipment chucks.

Plain Hand Rubbing Bricks – are the choice of mechanics and foundrymen for dressing grinding wheels and cleaning or scouring castings.

Fluted Hand Rubbing Bricks – are used by masons and stone workers for rubbing down concrete and removing mold marks. The diagonal flutes provide sharp edges, a clean shearing action, and carry away debris.

Fluted Hand Rubbing Bricks with Handle – make quick work of removing mold marks and rubbing down concrete. The firmly attached handle reduces fatigue and facilitates overhead, wall, and floor work.

GRIT RANGE:

6 – 120

ABRASIVE TYPE:

Silicon Carbide



AVAILABILITY

TIER:

BETTER

BRAND

Norton

ABRASIVE:

Silicon Carbide

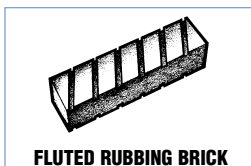
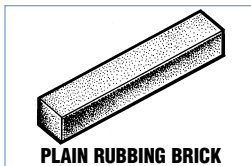
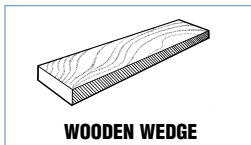

SIZE (L X W X H)	QTY/ PKG.	QTY./ CASE	SPEC	PRODUCT NO.	PART NO.
PLAIN FLOOR RUBBING BRICKS WITH WOODEN WEDGES					
4 x 2 x 2	1	6	C6-R		61463653292
			C10-R		61463653293
			C24-R		61463653294
			C80-R		61463653295
FLOOR RUBBING BRICK WITH CENTER SCORE					
8 x 2 x 2	1	5	C120-R*		61463685296*
WOODEN WEDGES					
	6	6			61463685297
PLAIN HAND RUBBING BRICKS					
8 x 2 x 2	1	5	C24	BP28	61463687830
FLUTED HAND RUBBING BRICKS					
6 x 2 x 2	1	5	C20	BF26	61463687840
8 x 2 x 2	1	5	C20	BF28	61463687845
FLUTED HAND RUBBING BRICKS WITH HANDLE					
6 x 3 x 1	1	5	C20	BFH6	61463687800
8 x 3-1/2 x 1-1/2	1	5	C20	235	61463687795

* 8" BRICK HAS A CENTER SCORE TO FACILITATE DIVIDING THE BRICK IN HALF – AN ECONOMICAL ALTERNATIVE TO BUYING TWO 4" BRICKS.





NORTON **SG**
BLAZE®

NorZon®
BLUEFIRE™

MERIT



CATEGORY DEFINITION

The most heavy-duty of coated abrasive discs with resin over resin construction on heavy-duty vulcanized fiber backing. Designed for applications ranging from heavy stock removal to surface blending. Used with back-up pads on portable angle grinders.

- APPLICATIONS: Stock removal, edge chamfering, weld blending, deburring/deflashing, rust removal, cleaning and finishing
- SIZE RANGE: 4" x 5/8" hole, 4-1/2" – 9-1/8" x 7/8" hole
- GRIT RANGE: 16 – 120
- ABRASIVE GRAIN: Ceramic Alumina, Zirconia Alumina, Aluminum Oxide, Silicon Carbide
- PRODUCT OPTIONS: Speed-Change hubs (5/8-11"), AVOS technology
- ACCESSORIES: Air-cooled and smooth-faced back-up pads

MATERIAL-TO-PRODUCT RECOMMENDATION GUIDE

	BEST HIGHEST PRODUCTIVITY LOWEST TOTAL COST	BETTER EXCELLENT BLEND OF PERFORMANCE & PRICE	GOOD CONSISTENT PERFORMANCE LOW INITIAL PRICE
Stainless Steel / Titanium / Super Alloys*	Norton SG Blaze F980	Norton NorZon BlueFire F826	Merit Metal A/O
Mild Carbon Steel / Welds	Norton SG GreenLyte F968	Norton NorZon BlueFire F826	Merit Metal A/O
Ferrous Metals / Cast Iron	Norton SG GreenLyte F968	Norton NorZon BlueFire F826	Merit Metal A/O
Brass / Bronze / Aluminum	–	Norton Metalite F220	Merit Metal A/O
Paint / Glue / Stonework	–	Norton FastCut Silicon Carbide	Merit Metal A/O

*NICKEL/COBALT BASED – HASTELLOY, ICONEL, WASPALLOY

APPLICATION/GRIT RECOMMENDATION GUIDE

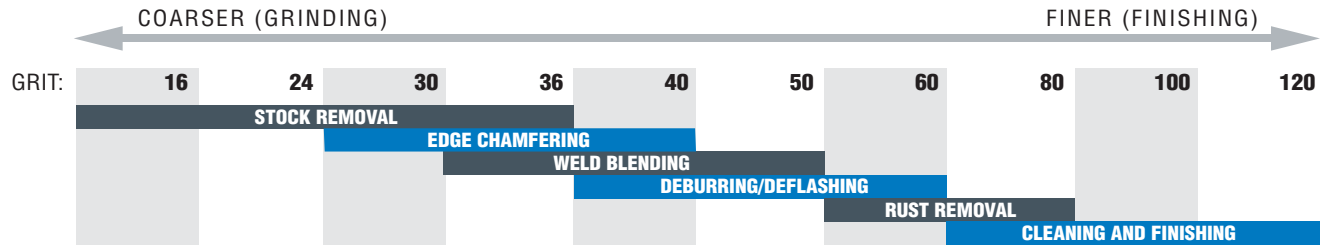

CROSS REFERENCE GUIDE

	TOTAL PERFORMANCE			INITIAL PRICE				
	BEST		BETTER			GOOD		
NORTON	SG Blaze F980	SG GreenLyte F968	NorZon BlueFire F826	Metalite F220		Metalite F226		
MERIT			Ceramic	Z/A		Metal		
3M	985C, 982C	988C, 983C	785C	501C	–	280C	381C	281C GreenCorp
Camel	–	–	Ceramic Blend	–	Zirconia	A/O Open	–	A/O
Flexovit	–	–	Flexon CG	Flexon	–	–	Specialist	High Perf
GemTex	–	–	X, PMD	–	ZEE	SMD	–	A
Hermes	CB844X	CB444X/J	–	RB414X/J	–	–	RB314X/J	–
Klingspor	CS661	–	–	CS570	CS565	–	–	CS561
Metabo	–	–	–	–	Z/A	–	–	A
Mirka	–	–	–	Blue A/Z	Gold A/Z	–	–	Red A/O
Pearl	–	–	–	–	Zirconia	–	A/O Premium	A/O Silver
Pferd	CO Cool	CO	CO-PMD	Z Cool	Z	–	A Cool	A
Sait	9S	8S	–	3Z	Z	–	3A	A, 2A
SIA	–	4515	–	4815	4819	–	–	4919
Standard	–	–	Ceramic	–	Zirconia	–	A/O Extra	A/O
VSM	XF870	XF750	ZF844	ZF745	ZF713, ZF714	–	KF808	KF708
Walter	–	–	–	Topcut, Inox	–	–	Coolcut	–
Weiler	–	–	–	–	Zirconium	–	–	A/O



FEATURED PRODUCTS



NORTON SG BLAZE F980

BEST CHOICE FOR STAINLESS STEEL, TITANIUM, AND SUPER ALLOYS

FEATURES

- Patented, new generation ceramic alumina grain
- Full-ratio / 100% ceramic alumina grain
- Self-lubricating, advanced supersize treatment
- Improved resin bond system
- Extra heavy-duty backing on 50 grit & coarser
- Foil-packed availability

BENEFITS

- Improved micro-fracturing for sharper grain edges and improved grain life
- Significant cut rate and life over competitive blended/low-ratio ceramic alumina discs
- Reduced heat, loading and glazing on stainless, titanium and super alloys
- Improved grain retention for longer life
- Increased life and durability
- Improved humidity and prevention against curl
- Fully recyclable for reduced landfill waste



NORTON SG GREENLYTE F968

BEST CHOICE FOR CARBON STEEL, WELDS, FERROUS METALS, AND CAST IRON

FEATURES

- Premium, patented, self-sharpening full-ratio ceramic abrasive grain

BENEFITS

- Faster initial cut rate, longer life and improved finishes versus competitive ceramic



NEW

NORTON NORZON BLUEFIRE F826

BETTER CHOICE FOR STAINLESS, SUPER ALLOYS, STEEL, CAST IRON, AND HIGH-PRESSURE APPLICATIONS

FEATURES

- New, improved blend of patented ceramic alumina and zirconia alumina abrasive

BENEFITS

- Fast, aggressive cutting
- Self-sharpens with use



NEW

NORTON METALITE F220

BETTER CHOICE FOR SOFT METALS

FEATURES

- High-performance aluminum oxide
- Paraffin wax coating

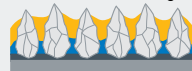

BENEFITS

- Low initial price with consistent performance
- Minimizes loading without sacrificing life, while providing excellent cut
- Reduces heat at the point of contact, so disc remains free-cutting and lasts longer
- Less pressure required for optimum performance



NEW

NORTON FASTCUT TYPE 27

BETTER CHOICE FOR PAINT, GLUE, ADHESIVE, AND STONWORK

FEATURES

- Extra coarse 16 grit, sharp silicon carbide abrasive grain
- Engineered specifically with cooling ridges
- Type 27 flat faced, depressed center shaped, with rigid fiber backing

BENEFITS

- Quickly penetrates and removes any coatings (adhesives, paint, acrylics, mastics, etc.)
- Aggressively grinds concrete, marble, granite, and other stonework
- Minimize loading by creating an interrupted cut
- Remain free-cutting and last longer
- Ideal for demanding right angle grinding, at comfortable low angles



NEW

MERIT METAL

GOOD STARTING SPECIFICATION FOR ALL METALS

FEATURES

- High-performance aluminum oxide

BENEFITS

- Low initial price with consistent performance



AVAILABILITY



TIER:	BEST	BEST	BETTER	BETTER	BETTER
BRAND:	Norton	Norton	Merit	Norton	Merit
TRADENAME:	NORTON SG BLAZE F980	SG GREENLYTE F968	CERAMIC	NORZON BLUEFIRE F826	ZA
ABRASIVE:	Ceramic Alumina	Ceramic Alumina	Ceramic Alumina	Ceramic/Zirconia	Zirconia Alumina
OTHER:	Supersize				

SIZE (D X H)	GRIT	STD. PKG.	PART NO.	PART NO.	PART NO.	PART NO.	PART NO.
4-1/2 x 7/8	24	25	69957398000	66261141313	66623355601	66261138457	66623353315
	30		66254425334				
	36		69957398001	66261141312	66623355602	66261138456	66623353316
	40			66261058701			
	50		69957398002	66261141311	66623355603	66261138454	66623353318
	60		69957398003	66261141310	66623355604	66261138453	66623353319
	80		69957398004	66261141309	66623365598	66261138452	66623353320
	100			66261141308			
	120		66254425332	66261141307			
5 x 7/8	24	25	69957398005	66261141320	66623355597	66261138563	66623357290
	50		66254464822#				
	30	25	66254425333				
	36	25	69957398006	66261141319	66623355598	66261138562	66623357291
	50		66254464821#				
	40	25		66261058702			
	50	25	69957398007	66261141318	66623355599	66261138561	66623357292
	50		66254464820#				
	60	25	69957398008	66261141317	66623355600	66261138601	66623357293
	80	25	69957398009	66261141316	66623366015	66261138600	66623357294
	100		66261141315				
	120		66254409084	66261141314			
7 x 7/8	24	25	69957398010	66261141327	66623355578	66261138594	66623357295
	50		66254464819#				
	30	25	66254420653				
	36	25	69957398011	66261141326	66623355594	66261138593	66623357296
	50		66254464816#				
	40	25		66261058703			
	50	25	69957398012	66261141325	66623355595	66261138592	66623357297
	50		66254464815#				
	60	25	69957398013	66261141324	66623355596	66261138591	66623357298
	80	25	69957398014	66261141323	66623365600	66261138590	66623357299
	100		66261141322				
	120		66254411528	66261141321			
9-1/8 x 7/8	24	25	69957398015	66261141344	05539510782	66261138584	
	36		69957398016	66261141343	05539510749	66261138583	
	50		69957398017		05539510748	66261138582	
	60			66261141341			
	80			66261141340			
	100			66261141339			

SHRINK-WRAP FOIL PACK: 10 DISCS PER PACK, 5 PACKS PER STANDARD PACKAGE

NOTE: FIBER DISCS MUST ALWAYS BE USED WITH BACK-UP PADS, SHOWN ON THE LAST PAGE OF THIS SECTION

Foil Packaging for Norton SG Blaze!

Controlled humidity prevents curl, 10 per pack



NorZon BlueFire F826

Faster and cooler cutting with new patented abrasive blend





AVAILABILITY

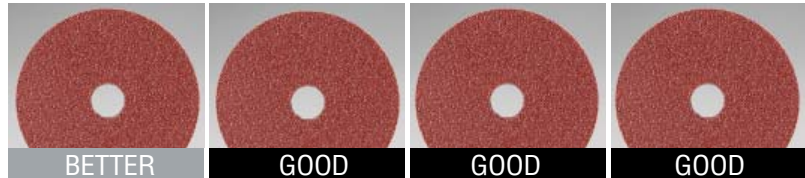

TIER:	BETTER	GOOD	GOOD	GOOD
BRAND:	Norton	Norton	Norton	Merit
TRADENAME:	METALITE F220	METALITE F226	METALITE F226	MERIT METAL
ABRASIVE:	Aluminum Oxide	Aluminum Oxide	Aluminum Oxide	Aluminum Oxide
OTHER:	Paraffin Fill		Individual UPC Barcode	

SIZE (D X H)	GRIT	STD. PKG.	PART NO.	PART NO.	PART NO.	PART NO.
4 x 5/8	24	25		66261133434	07660704709**	05539510595
	36			66261133433	07660704710**	05539510594
	50			66261133432	07660704711**	05539510593
	60			66261133431		05539510592
	80			66261133430		05539510591
	100			66261133429		
	120			66261133428		
4-1/2 x 7/8	24	25	66254400694	66261133519	07660704712**	66623353309
	36			66261133517	07660704713**	66623353306
	50			66254400696	07660704714**	66623353310
	60			66254400698		66623353311
	80			66254400700		66623353312
	100				66623353313	
	120				66623353314	
5 x 7/8	16	25	66254400692	66261133617		05539510684
	24			66261133615	07660704706**	66623357276
	36			66261133610	07660704707**	66623357277
	50			66254400688	07660704708**	66623357278
	60			66254400690		66623357279
	80			66254400691		66623357280
	100				66623357281	
120		66623357282				
7 x 7/8	16	25	66254400702	66261133760		05539510693
	24			66261133755	07660704703**	66623357283
	36			66261133750	07660704704**	66623357284
	50			66254400703	07660704705**	66623357285
	60			66254400704		66623357286
	80			66254400705		66623357287
	100				66623357288	
120		66623357289				
9-1/8 x 7/8	16	25		66261133890		
	24			66261133885		05539510702
	36			66261133880		05539510701
	50			66261133875		05539510700
	60			66261133870		05539510699
	80			66261133865		
	100			66261133860		
120	66261133855		05539510695			

** 10 PER STD. PKG.

NOTE: FIBER DISCS MUST ALWAYS BE USED WITH BACK-UP PADS, SHOWN ON THE LAST PAGE OF THIS SECTION

Norton Metalite F226 Discs

Individual UPC Bar-Coded

- High-performance aluminum oxide fiber discs at market competitive prices
- Job Packs with 10 per box; ideal for walk-in displays and small contractor purchases
- All discs are UPC bar-coded and can be sold individually





Speed-Change

These fiber discs feature Norton quick, tool-free, twist-on and off Speed-Change fasteners. Discs lock to standard back-up pads with a unique nut design and are easily removed, increasing your productivity with more time to grind.

AVAILABILITY

SIZE (D X H)	GRIT	STD. PKG.	PART NO.	PART NO.	PART NO.
4-1/2 x 5/8-11	24	25	66261023269		
	36		66261185294		
5 x 5/8-11	24	25	66254425336	66261138797	
	36		66261185801	66261138796	66261137522
	60				66261137515
7 x 5/8-11	24	25	69957349782	66261138819	66261137625
	36		66261029863	66261138818	66261137620
	50			66261138817	66261137615
	60			66261138816	
	80				66261137605
	100				66261137600
	120			66261137595	

TIER:	BEST	BETTER	GOOD
BRAND:	Norton	Norton	Norton
TRADENAME:	NORTON SG BLAZE F980	NORZON BLUEFIRE F826	METALITE F226
ABRASIVE:	Ceramic Alumina	Ceramic/Zirconia	Aluminum Oxide
OTHER:	Supersize		

NOTE: SPEED-CHANGE FIBER DISCS MUST ALWAYS BE USED WITH BACK-UP PADS, SHOWN ON THE LAST PAGE OF THIS SECTION

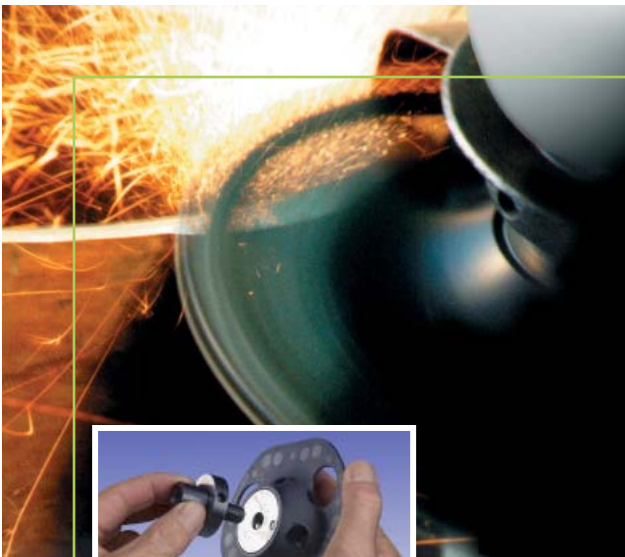

AVOS Fiber Discs and Speed-Lok Back-up Pads

- Patented, see-through design allows interrupted cut which reduces heat up to 30% over standard discs
- The scooped holes create air flow to pull swarf away from grinding zone; cool cutting and extended product life
- 5" back-up pad for full utilization of discs – no gouging
- Quick, tool-free, twist-on and -off Speed-Lok fasteners

AVAILABILITY

SIZE	GRIT	STD. PKG.	PART NO.	PART NO.
4-1/2" Speed-Lok (3 hole)	24	10	66254468389	66261129718
	36		66254468390	66261129719
	50		66254468391	66261129720
	60		66254468392	66261129721
	80		66254468393	66261129722
5" Speed-Lok (3 hole)	24	10	66254468385	66261126556
	36		66254468386	66261126557
	50		66254468387	66261126558
	60		66254468388	66261126559
	80			66261126560
7" Speed-Lok (6 hole)	24	10	66254468381	66261137454
	36		66254468382	66261137455
	50		66254468383	66261137456
	60		66254468384	66261137457
	80			66261137458

TIER:	BEST	BETTER
BRAND:	Norton	Norton
TRADENAME:	NORTON SG BLAZE F980	NORZON BLUEFIRE F826
ABRASIVE:	Ceramic Alumina	Ceramic/Zirconia

SIZE	RPM	STD. PKG.	PART NO.
AVOS Triangular Speed-Lok Back-up Pads			
4-1/2" x 5/8-11	13,000	5	63642502985
5" x 3/8-24 Pistol Grip*	20,000	5	63642503029
5" x 5/8-11	13,000	5	63642502517
5" x 7/16-20 Pistol Grip*	20,000	5	63642503030
AVOS Round Speed-Lok Back-up Pads			
7" x 5/8-11 Hard	8,600	5	63642504873
7" x 5/8-11 Medium	8,600	5	63642504874

*USE ON AIR PNEUMATIC AND HIGH-SPEED PISTOL GRIP SANDERS

NOTE: AVOS FIBER DISCS MUST BE USED WITH AVOS BACK-UP PADS SHOWN AT LEFT



Air-Cooled Standard Back-up Pad

Slotted hub design and curved ribs draw heat away from the grinding zone, reducing disc loading and increasing life. All pads have a 5/8"-11 threaded female hub for mounting. We also offer a no-nose for shorter-shafted right angle grinders.



Smooth Face Back-up Pad

Molded rubber back-up pads with a smooth face.

- Hard density pads are for aggressive cutting action
- Medium density pads are for all-purpose applications
- Soft density pads are used for contours and fine finishing work

DESCRIPTION	MAX. RPM	STD. PKG.	PART NO.
RUBBER BACK-UP PADS			
AIR COOLED STANDARD			
4" Medium	12,000	5	63642504918
4-1/2" Medium	11,000	5	63642502122
5" Medium	10,000	5	63642543421
7" Hard	8,600	5	63642543425
7" Medium	8,600	5	63642543422
9" Hard	6,600	5	63642543426
9" Medium	6,600	5	63642543423

NOTE: RETAINER NUTS ARE NOT INCLUDED WITH BACK-UP PADS. THESE MUST BE ORDERED SEPARATELY.

AIR COOLED NO-NOSE			
4-1/2" Medium	11,000	5	63642504872
5" Medium	10,000	5	63642503000
7" Medium	8,600	5	66254487375

SMOOTH FACE / SPEED-CHANGE			
4-1/2" Medium	20,000	5	66254492277
5" Medium	12,000	5	63642543235
7" Hard	8,600	5	63642543240
7" Medium	8,600	5	63642543245
7" Soft	8,600	5	63642543250
9" Medium	7,000	5	63642543270

TOOLS			
#103 Retainer Nut	—	10	63642543463
Spanner Wrench	—	5	63642543005
66NS Short Retainer Nut	—	10	63642543461

FastCut Fiber Discs

Type 27 (flat-faced), semi-rigid fiber-backed discs with extra sharp, 16 grit silicon carbide abrasive, are engineered specifically with cooling ridges for an interrupted cut to efficiently grind softer materials (marble, granite, concrete, etc.) where loading is a problem.

Cooling ridges minimize loading to remain free-cutting and last longer.

AVAILABILITY

TIER:	BETTER
BRAND:	Norton
TRADENAME:	FASTCUT TYPE 27
ABRASIVE:	Silicon Carbide
OTHER:	Semi-Rigid

SIZE (D X H)	GRIT	STD. PKG.	PART NO.
4-1/2 x 7/8	16	25	66261199054
7 x 7/8	16	25	66261199052

NOTE: FASTCUT DISCS MUST BE USED WITH BACK-UP PADS ABOVE







NORTON *SG*
BLAZE

Norton
BLUEFIRE

TWIN★STAR™

MERIT



CATEGORY DEFINITION

Flap discs are versatile grinding and finishing tools, consisting of three main components: a backing plate, adhesive, and abrasive cloth flaps. The rectangular flaps are overlapped and glued to the backing plate. Flap discs are designed for right angle grinder applications ranging from heavy stock removal to surface blending.

APPLICATIONS:	Grinding, stock removal, edge chamfering/beveling, weld blending, deburring/deflashing, rust removal, blending, cleaning and finishing
SIZE RANGE:	4": 5/8" hole 4-1/2" - 7": 5/8"-11 discard mount and 7/8" hole
GRIT RANGE:	24 – 120
ABRASIVE GRAIN:	Ceramic Alumina, Zirconia Alumina, Aluminum Oxide, Silicon Carbide
ABRASIVE FLAPS:	Polyester or cotton
FLAP DISC SHAPE:	Type 27 Flat and Type 29 Conical
ABRASIVE FLAP DENSITY:	Standard or high
BACKING PLATE MATERIAL:	Fiberglass, plastic or aluminum

FLAP DISC SHAPES

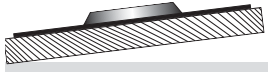

GRIND AT FLATTER ANGLES:
0° – 15°

Type 27 Flat – The Best Choice for Finishing

- Used primarily on flat surfaces
- The best choice for blending and smooth finishing

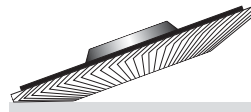

GRIND AT STEEPER ANGLES:
15° – 25°

Type 29 Conical – The Best Choice for Aggressive Stock Removal

- Conical flap discs have angled flaps and may be used on both contoured and edge work
- The angle provides greater surface contact for stock removal on flat surfaces
- The best choice when speed and stock removal are primary considerations

ABRASIVE FLAP DENSITIES



Standard Density

- Excellent for heavy-duty applications and rapid stock removal



High Density

- Ideal when working on uneven or curved surfaces, as well as finer grit blending

BACKING PLATE MATERIALS

All flap discs are a combination of abrasive flaps adhered to a rigid backing plate. It is the backing plate that provides stability during operation. There are three main materials used: fiberglass, plastic or aluminum. The fiberglass backing plate, along with the flap shape, helps to absorb vibration and is consumed during use with no smearing. Fiberglass is the most popular material because of its high strength and light weight. The plastic backing plate offers some additional conformability and is trimmable. The aluminum backing plate provides extra high strength and rigid support as needed. While not consumable during use, an aluminum plate can be recycled.

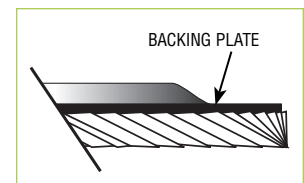

WHY CHOOSE FLAP DISCS?

Flap discs replace both grinding wheels and fiber discs. The same flap disc can be used for applications ranging from stock removal to blending.

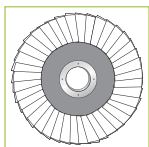

Flap Discs vs. Grinding Wheels

- Faster stock removal
- Smoother finish, no gouging
- Cooler cutting, less glazing
- Lightweight, easier to control
- Less vibration, less operator fatigue
- Reduced noise

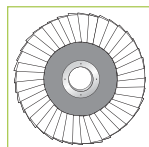
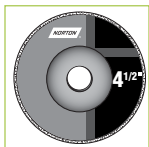

Flap Discs vs. Fiber Discs

- 20X longer life, reduced abrasive cost
- Fewer disc changes, reduced labor cost
- More consistent finish
- No back-up pad required
- Easier storage, no curling
- Reduced loading
- Use flap discs one grit size coarser than fiber discs, except in 36 grit.

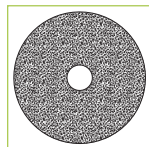



MATERIAL-TO-PRODUCT RECOMMENDATION GUIDE

	BEST HIGHEST PRODUCTIVITY LOWEST TOTAL COST	BETTER EXCELLENT BLEND OF PERFORMANCE & PRICE	GOOD CONSISTENT PERFORMANCE LOW INITIAL PRICE
TYPE 29 FOR STOCK REMOVAL			
Stainless Steel / Titanium / Super Alloys	Norton SG Blaze R980P	NorZon BlueFire R884	Merit Metal
Mild Carbon Steel / Welds	Norton TwinFiber	NorZon BlueFire R884	Merit Metal
Ferrous Metals / Cast Iron	Norton TwinFiber	NorZon BlueFire R884	Merit Metal
Brass / Bronze / Aluminum	–	NorZon BlueFire R884	Merit Silicon Carbide
Paint / Glue / Adhesive	–	–	Merit Silicon Carbide
Concrete / Stone / Fiberglass	–	–	Merit Silicon Carbide
TYPE 27 FOR BLENDING AND FINISHING			
Stainless Steel / Titanium / Super Alloys	Norton SG Blaze R980P	NorZon BlueFire R884	Merit Metal
Mild Carbon Steel / Welds	Norton TwinStar	NorZon BlueFire R884	Merit Metal
Ferrous Metals / Cast Iron	Norton TwinStar	NorZon BlueFire R884	Merit Metal
Brass / Bronze / Aluminum	–	NorZon BlueFire R884	Merit Metal

APPLICATION/GRIT RECOMMENDATION GUIDE

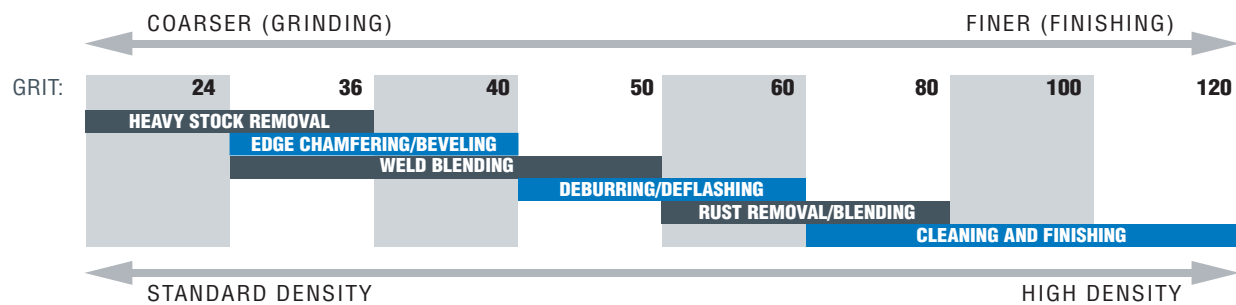

CROSS REFERENCE GUIDE

	TOTAL PERFORMANCE		INITIAL PRICE	SPECIALTY	
	BEST SG Blaze R980P	TwinFiber / TwinStar	BETTER NorZon BlueFire R884	GOOD	
				Metal / Zirconia	Silicon Carbide
NORTON					
MERIT					
3M	947D	747D	563D, 546D	–	–
DeWalt	–	–	–	Z/A	–
Camel	–	C3	Z-Stainless	Z3, A3	SC
Flexovit	–	–	–	Zircotex Premium, Zircotex HP	–
Garryson	–	–	Zirc+, Zirconium	Aluminum Oxide	–
GemTex	–	Ceramic	–	Zirconia, A/O	–
Hermes	–	–	–	–	–
Klingspor	–	–	SMT 630	SMT 618, 619, 624, 626, 627, 628, 640	–
Metabo	–	–	–	Z/A	–
Pearl	–	Stainless Max	Zirconia Premium, TuffMax	Z/A Silver Line, Premium A/O Classic, Silver Line	SC
Pferd	–	Ceramic	Cool Zirconia, CO-COOL	Zirconia, Cool Aluminum Oxide, Aluminum Oxide	Masonry Silicon Carbide
Sait	–	–	Z	2A, 3A	–
SIA	–	–	–	Z/A	–
Standard	–	Ceramic Oxide	Zirconia Pro	Zirconia	–
Tyrolit	–	–	Z/A	A/O	–
Walter	–	–	Enduro Flex	–	–
Weiler	–	Saber Tooth Ceramic	–	Tiger Zirconium, A/O, Vortec	–



FEATURED PRODUCTS



IMPROVED

NORTON SG BLAZE R980P / QUICK TRIM NORTON SG BLAZE R980P
 BEST/HIGHEST PRODUCTIVITY FOR STAINLESS STEEL, TITANIUM, AND SUPER ALLOYS

FEATURES	BENEFITS
• Latest-generation ceramic alumina abrasive grain	• Last 50% – 200% longer than any flap discs on stainless steel, cobalt, chrome, Inconel, titanium and other hard-to-grind materials
• Supersize grinding aid	• Cool, noticeably fast cut rate
• Y-wt. polyester flaps	• Significantly improve life, grain retention and fray resistance
• Durable fiberglass back	• High strength, lightweight, absorbs vibration
• NEW! Orange, flexible plastic backing plate on Type 27 Quick Trim	• New industry standard for trimmability



IMPROVED

TWINFIBER / TWINSTAR
 BEST/HIGH PRODUCTIVITY FOR MILD CARBON STEEL, AND FERROUS METALS

FEATURES	BENEFITS
• New, premium ceramic and zirconia alumina abrasive blend	• Excellent performance and efficiencies on mild carbon steel and ferrous metal/cast iron applications
• Durable, fiberglass back (Type 29 TwinFiber)	• High strength, lightweight, absorbs vibration
• New plastic backing plate material (Type 27 TwinStar)	• New industry standard for trimmability

NEW



NEW

NORZON BLUEFIRE R884
 BETTER CHOICE FOR MILD CARBON STEEL, AND WELDS

FEATURES	BENEFITS
• High performance zirconia alumina plus abrasive	• Aggressive cut and long life
• Polyester flaps	• Up to 30% longer life than competitive zirconia alumina products
• Durable, fiberglass back	• Improved durability
• Semi-open coat	• High strength, lightweight, absorbs vibration
	• Retards loading on aluminum



NEW

MERIT METAL
 GOOD CHOICE FOR STAINLESS STEEL, CAST IRON, AND ALUMINUM

FEATURES	BENEFITS
• Quality zirconia alumina abrasive	• Good cut rate and life
	• Type 29 for hard to grind materials
	• Type 27 for softer materials
• Engineered blend of X-wt. cotton and Y-wt. polyester flaps	• Longer life and wear resistance
• Durable, fiberglass back	• High strength, lightweight, absorbs vibration
• Competitive initial price point	• Best starting specification for end-user unable to measure performance



NEW

MERIT SILICON CARBIDE
 GOOD CHOICE FOR BRASS, BRONZE AND NON-METALS

FEATURES	BENEFITS
• Silicon carbide abrasive	• Good for very soft (aluminum) to very hard (concrete) materials
• Durable, fiberglass back	• High strength, lightweight, absorbs vibration
• Competitive initial price point	• Ideal starting specification for end-user unable to measure performance



AVAILABILITY

TIER:	BEST				
BRAND:	Norton				
TRADENAME:	SG BLAZE R980P	SG BLAZE R980P	TWINSTAR	SG BLAZE R980P	TWINFIBER
SHAPE:	Type 27 Flat	Type 27 Flat	Type 27 Flat	Type 29 Conical	Type 29 Conical
FLAP DENSITY:	Standard	Standard	Standard	Standard	Standard
ABRASIVE:	Ceramic Alumina	Ceramic Alumina	Ceramic Alumina/ Zirconia Alumina	Ceramic Alumina	Ceramic Alumina/ Zirconia Alumina
BACKING PLATE:	Fiberglass	Quick Trim Plastic	Quick Trim Plastic/*Plastic	Fiberglass	Fiberglass
OTHER:	Supersize	Supersize		Supersize	

SIZE (D X H)	GRIT	MAX. RPM	STD. PKG.	PART NO.	PART NO.	PART NO.	PART NO.	PART NO.
4 x 5/8	40	15,300	10			63642536153*		
	60				63642536154*			
	80				63642536155*			
	120							
4-1/2 x 5/8-11	36	13,300	10	66261100005	66254400257	63642536147•	66261183490	63642536156•
	40			66261100006	66254400258	63642536148•	66261183491	63642536157•
	60			66261100007	66254400259	63642536149•	66261183492	63642536158•
	80			66261100008	66254400261		66261183493	63642597115•
4-1/2 x 7/8	36	13,300	10	66261100001	66254400253	63642504876*	66261183486	63642504329
	40			66261100002	66254400254	63642504877*	66261183487	63642504330
	60			66261100003	66254400255	63642504878*	66261183488	63642504331
	80			66261100004	66254400256	63642504879*	66261183489	63642504332
5 x 7/8	36	12,000	10	66261100009	66254400262	63642505281*	66261190001	
	40			66261100010	66254400264	63642505282*	66261190002	
	60			66261100011	66254400265	63642505283*	66261190003	
	80			66261100012	66254400519	63642505284*	66261190004	
5 x 5/8-11	40	12,000	5			66254491941		
	60				66254491942			
	80				66254491943			
6 x 7/8	40	10,200	10					63642541406
	60							63642541407
	80							63642541408
	120							
7 x 5/8-11	36	8,600	10	66261100017	66254461066	63642536150•	66261183498	63642536159•
	40			66261100018	66254461067	63642536151•	66261183499	63642536160•
	60			66261100019	66254461068	63642536152•	66261183500	63642536161•
	80			66261100020	66254461069		66261183501	
7 x 7/8	36	8,600	10	66261100013	66254461059	63642504880*	66261183494	63642504334
	40			66261100014	66254461060	63642504881*	66261183495	63642504335
	60			66261100015	66254461061	63642504882*	66261183496	63642504336
	80			66261100016	66254461063	63642504883*	66261183497	63642504337
120					66261183497	63642504338		

* 5/8-11 (HUBBED) TWINSTAR AND TWINFIBER FLAP DISC STD. PKG. QUANTITY = 5



New Trimmable, Flexible Plastic Backing Plate

Quick Trim Norton SG Blaze R980P and TwinStar

New higher-performance abrasive flaps are mounted on our new flexible, easily-trimmable plastic backing plate. For custom sizes or to fully use the flaps, the new Quick Trim flap discs are the answer. Available in 7/8" hole or our industry standard 5/8-11 mini mount that ensures maximum safety for all right angle grinders.



AVAILABILITY



TIER:	BETTER	BETTER
BRAND:	Norton	Norton
TRADENAME:	NORZON BLUEFIRE R884	NORZON BLUEFIRE R884
SHAPE:	Type 27 Flat	Type 29 Conical
FLAP DENSITY:	Standard	Standard
ABRASIVE:	Zirconia Alumina Plus	Zirconia Alumina Plus
BACKING PLATE:	Fiberglass	Fiberglass

SIZE (D X H)	GRIT	MAX. RPM	STD. PKG.	PART NO.	PART NO.
4-1/2 x 5/8-11	36	13,300	10	66254461202	66254461165
	40			66254461203	66254461167
	60			66254461204	66254461170
	80			66254461206	66254461173
4-1/2 x 7/8	36	13,300	10	66254461196	66254461155
	40			66254461197	66254461161
	60			66254461198	66254461163
	80			66254461200	66254461164
5 x 7/8	36	12,000	10	66254461208	66254461174
	40			66254461209	66254461176
	60			66254461210	66254461177
	80			66254461212	66254461178
7 x 5/8-11	36	8,600	10	66254461219	66254461188
	40			66254461221	66254461190
	60			66254461223	66254461192
	80			66254461225	66254461193
7 x 7/8	36	8,600	10	66254461213	66254461180
	40			66254461215	66254461183
	60			66254461216	66254461185
	80			66254461217	66254461186

When You Want Fast and Tough, You Want Norton

Whether you want maximum productivity or simply the lowest initial cost solution, Norton and Merit have the product for all your right angle grinding and blending applications.



BEST Norton SG Blaze

Highest Productivity, Lowest Total Cost

Latest-generation ceramic alumina abrasive provides the industry's fastest cutting discs and 50-200% longer life over any flap disc on stainless, titanium, and super alloys.



BETTER NorZon BlueFire

Exceptional Blend of Performance and Price

New zirconia alumina plus abrasive for an increased cut rate and up to 30% longer life over conventional zirconia products on carbon steel and welds.



GOOD Merit Metal

Good Performance, Low Initial Price

Engineered blend of two high performance zirconia products provides the best starting specification when price is primary consideration.



AVAILABILITY



TIER:	GOOD	GOOD	GOOD	GOOD	GOOD	GOOD
BRAND:	Merit	Merit	Merit	Merit	Merit	Merit
TRADENAME:	METAL	ZIRCONIA	METAL	ZIRCONIA	ZIRCONIA	SILICON CARBIDE
SHAPE:	Type 27 Flat	Type 27 Flat	Type 29 Conical	Type 29 Conical	Type 29 Conical	Type 29 Conical
FLAP DENSITY:	Standard	High	Standard	Standard	High	Standard
ABRASIVE:	Zirconia Alumina	Zirconia Alumina	Zirconia Alumina	Zirconia Alumina	Zirconia Alumina	Silicon Carbide
BACKING PLATE:	Fiberglass	Fiberglass	Fiberglass	Fiberglass	Fiberglass	Fiberglass

SIZE (D X H)	GRIT	MAX. RPM*	STD. PKG.	PART NO.	PART NO.	PART NO.	PART NO.	PART NO.	PART NO.
4 x 5/8	24	15,300	10				08834193722		
	36					08834193630			
	40					08834193645			
	60					08834193631			
	80					08834193632			
	120					08834193646			
4-1/2 x 5/8-11	24	13,300	10		08834191969		08834193726		
	36			66254472655	08834199749	66254419991	08834193679	08834194447	
	40			66254437013	08834194731	66254419994	08834193680	08834193906	
	60			66254472656	08834199750	66254419996	08834193681	66261044504	66254460664
	80			66254448989	08834190330	66254419997	08834193682	66261044505	08834196277
	120			66254472657	08834191941		08834193683	66261044506	08834196275
4-1/2 x 7/8	24	13,300	10		08834194834		08834193723	08834194833	
	36			66254472653	08834192985	66254419963	08834193633	08834191427	
	40			66254437004	08834190172	66254419978	08834193647	08834190726	
	60			66254448989	08834190767	66254419984	08834193634	08834190175	66254460663
	80			66254448990	08834194360	66254419987	08834193635	08834190924	08834195676
	120				08834194841		08834193648	08834190995	08834195677
5 x 5/8-11	24	12,000	10				08834193727		
	36					08834193684			
	40					08834193685			
	60					08834193686			
	80					08834193687			
	120					08834193688			
5 x 7/8	24	12,000	10				08834193724		
	36			66254472659		66254419998	08834193649		
	40			66254472660	08834190074	66254420001	08834193650		
	60			66254472661	08834190376	66254420002	08834193651	08834190876	66254460694
	80			66254472662	08834192269	66254420003	08834193652	08834190405	66254460463
	120				08834192299		08834193653	08834192209	66254460464
6 x 5/8-11	24	10,200	10				66254407155		
	36					66254407157			
	40			66254491773		66254491779	66254407158		
	60			66254491774		66254491780	66254407159		
	80			66254491775		66254491781	66254407160		
	120						66254407161		
6 x 7/8	24	10,200	10				66261095708		
	36					66261095711			
	40			66254491770		66254491776	66261095716		
	60			66254491771		66254491777	66261095717		
	80			66254491772		66254491778	66261095718		
	120						66261095719		
7 x 5/8-11	24	8,600	10		08834191986		08834193728		
	36			66254472669	08834195073	66254420009	08834193689	08834193830	
	40			66254472670	08834191043	66254420010	08834193690	66261044540	
	60			66254472671	08834197227	66254420012	08834193691	08834199751	66254460666
	80			66254472672	08834191674	66254420013	08834193692	08834192896	08834197186
	120				08834191987		08834193693	66261044541	08834197187
7 x 7/8	24	8,600	10		08834194831		08834193725	08834190877	
	36			66254472664	08834194361	66254420004	08834193636	08834190878	
	40			66254472665	08834190933	66254420006	08834193654	08834192059	
	60			66254472666	08834194514	66254420007	08834193637	08834196985	66254460665
	80			66254472667	08834194362	66254420008	08834193638	08834196986	08834195705
	120				08834194832		08834193655	08834196988	66254460462

* MAX RPM FOR MERIT ZIRCONIA HIGH DENSITY FLAP DISCS IS 13,000



20X High Performance

- Zirconia alumina abrasive disc, packaged for retail/walk-in selling
- Individual hang card provides product selling points
- Product ships in merchandisable display case of small quantities



AVAILABILITY

TIER:	BEST
BRAND:	Norton
TRADENAME:	20X
SHAPE:	Type 29
FLAP DENSITY:	Standard
ABRASIVE:	Zirconia Alumina Plus
BACKING PLATE:	Fiberglass

SIZE (D X H)	GRIT	MAX. RPM	STD. PKG.	PART NO.
4 x 3/8-24	40	15,300	5	07660703214
	60			07660703215
	80			07660703216
4-1/2 x 5/8-11	40	13,300	5	07660703211
	60			07660703212
	80			07660703213
7 x 5/8-11	40	8,600	5	07660703205
	60			07660703206
	80			07660703207
Wire Rack			2	07660704157

Wire rack (with header card) allows merchandising of 4" and 4-1/2" product three ways: hung on pegboard, mounted on an upright, or placed on a shelf/counter



Merit Mini Flap Discs



- High performance zirconia alumina abrasive provides maximum cut rate and life
- Layered flaps wear away evenly, producing a high quality and consistent finish

AVAILABILITY

TIER:	BETTER	BETTER
ABRASIVE:	Zirconia Alumina	Zirconia Alumina
FLAP:	Cotton	Cotton
BACKING MATERIAL:	Extra Heavy Duty Plastic	Extra Heavy Duty Plastic
ATTACHMENT:	TS (Type II)	TR (Type III)



SIZE (D)	GRIT	STD. PKG.	PART NO.	PART NO.
2"	36	10	08834195020	08834194550
	40		08834195021	08834194551
	60		08834195022	08834194552
	80		08834195023	08834194553
	120		08834195024	08834194554
3"	36	10	08834195035	08834194563
	40		08834195036	08834194564
	60		08834195037	08834194565
	80		08834195038	08834194566
	120		08834195039	08834194567



TS (TYPE II)

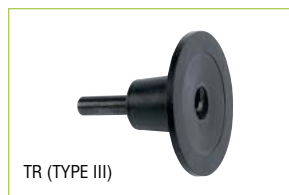

TR (TYPE III)

DESCRIPTION	STD. PKG.	MAX. RPM	PART NO.
MINI FLAP DISC BACK-UP PADS			
2" & 3" TS (Type II) Back-up Pads	1	30,000	08834168539
2" & 3" TR (Type III) Back-up Pads	1	30,000	08834160172



DRYice®



NORTON
GOLD A290™



CATEGORY DEFINITION

For use on random orbital and rotary sanders. The industry's highest performing and broadest selection of paper discs in PSA (pressure sensitive adhesive) disc rolls, individual discs, and hook and loop discs.

APPLICATIONS:	Stripping and preparing primed and painted surfaces for finishing, sanding of plastics, fiberglass and composites, bare wood sanding, light weld blending, preparing and finishing metal, and sanding of all gel coat and body filler compounds
SIZE RANGE:	3" – 8"
GRIT RANGE:	36 – 2500
ABRASIVE GRAIN:	Ceramic Alumina, Zirconia Alumina, Aluminum Oxide, Silicon Carbide
ATTACHMENT SYSTEMS:	PSA (pressure-sensitive adhesive), hook and loop
PAPER WEIGHTS:	Heavyweight – E and F Lightweight – A, B and C
VACUUM HOLES:	See product availability charts

MATERIAL/APPLICATION-TO-PRODUCT RECOMMENDATION GUIDE

	BEST HIGHEST PRODUCTIVITY LOWEST TOTAL COST		BETTER EXCELLENT BLEND OF PERFORMANCE & PRICE		GOOD CONSISTENT PERFORMANCE LOW INITIAL PRICE	
	Heavy-Medium Stock Removal	Light Stock Removal-Finishing	Heavy-Medium Stock Removal	Light Stock Removal-Finishing	Heavy-Medium Stock Removal	Light Stock Removal-Finishing
Primed, Painted Surfaces		A975	H875	A275	H290	PB273
Fiberglass / Composites / Gel Coats		A975	H875	A275	H290	PB273
Wood		A975	H875	A275	H290	PB273
Metal	H920	A975	H822	A275	H290	PB273
Body Fillers / Compounds / Plastics		A975	H875	A275	H290	PB273

APPLICATION/GRIT RECOMMENDATION GUIDE

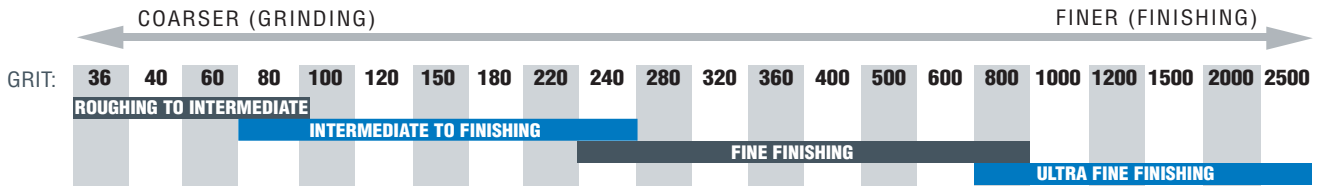

CROSS REFERENCE GUIDE

	TOTAL PERFORMANCE						INITIAL PRICE			
	BEST		BETTER			GOOD				
<i>NORTON</i>	Heavy-Wt. Norton SG H920	Light-Wt. Norton SG A975	Heavy-Wt. NorZon Plus H822	Heavy-Wt. NorZon Plus H875	Light-Wt. Adalox A275	Light-Wt. Adalox A270	Light-Wt. Durite A475	Heavy-Wt. Adalox H290	Light-Wt. Adalox A290	Light-Wt. Merit PB273
3M	763U, 7511	734U, 735U, 765L	–	750U, 751U, 740I, 745I	216U, 255L, 260L, 334U	210U, 268L, 360L	414N, 415N 405N, 415U, 435U	363I	236U	214U, 316U Red
Hermes	CB115	–	BW 115	–	VC154-LL	VC152	PSF-LL, SF168	VC152	HCAB-LL, HC135, VC151-LL	–
Indasa	–	–	–	–	RedLine	–	–	–	–	WhiteLine
Klingspor	–	PS36	PS20, PS21, PS22	–	PS33	–	PL35	–	PS33	PL36
Mirka	–	–	–	Royal Coarse Cut	Q-Silver, Royal, Silver Royal Micro	–	CaratFlex, PolarStar	–	Bulldog Gold	Carat (B)
SIA	–	1950	1820, 1919	1820, 1919	1940, 1950	–	1748	–	1947	–
VSM	–	–	–	KP510E, KP709	MPG	–	CP131A	–	KP911	MP10

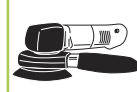

FEATURED PRODUCTS



NORTON SG H920
BEST CHOICE FOR MORE DEMANDING STOCK REMOVAL APPLICATIONS

FEATURES	BENEFITS
<ul style="list-style-type: none"> Patented Norton SG ceramic alumina abrasive Strong, heavy F-weight paper, synthetically-coated 	<ul style="list-style-type: none"> Maximum life; fast aggressive cutting action, yet cool cutting Maximum durability and chip resistance, ideal for soldered and welded areas, and unpainted metal applications



NO-FIL DRYICE NORTON SG A975
BEST CHOICE FOR THE MOST DEMANDING SANDING APPLICATIONS

FEATURES	BENEFITS
<ul style="list-style-type: none"> Patented P-graded Norton SG ceramic alumina abrasive Unique fiber-reinforced, flexible B- and C-wt. latex-saturated backing Water-based No-Fil stearate, non-pigmented 	<ul style="list-style-type: none"> Fastest cut rate; longest life of any paper disc 50-60% improvement in tear strength, longer life in all applications Flexible; can be used wet Provides maximum load resistance and extended life; no color transfer



NORZON H875
BETTER CHOICE FOR SOFT MATERIAL APPLICATIONS

FEATURES	BENEFITS
<ul style="list-style-type: none"> Patented NorZon zirconia alumina abrasive Strong, heavy, E-weight paper Open coat design 	<ul style="list-style-type: none"> Extended life over original zirconia alumina products Improved cut rate Increased durability and chip resistance, flexible Reduced loading; ideal for body-filler, fiberglass and composites



NO-FIL ADALOX A275
BETTER CHOICE FOR HIGH-PERFORMANCE DRY FINISHING ON ALL MATERIALS

FEATURES	BENEFITS
<ul style="list-style-type: none"> Premium P-graded, heat-treated aluminum oxide abrasive Unique fiber-reinforced, flexible B-wt. latex-saturated backing Water-based stearate, non-pigmented, No-Fil coating 5" and 6" individual PSA discs in fine grits have a tabbed, white translucent liner 	<ul style="list-style-type: none"> Superior life, fast cut rate, consistent finish 50-60% improvement in tear strength Flexible; can be used wet Provides maximum load resistance and extended life; no color transfer to work The PSA adhesive is protected from air-borne contaminants The tab allows easier removal of the paper liner



NEW

NO-FIL DURITE A475
BETTER CHOICE FOR HARD-TO-SAND SURFACES AND WOOD APPLICATIONS

FEATURES	BENEFITS
<ul style="list-style-type: none"> P-graded, hard, silicon carbide abrasive Water-based stearate, non-pigmented, No-Fil coating Durable, fiber-reinforced, B-wt. latex paper 	<ul style="list-style-type: none"> Easy penetration of the hardest surfaces Resists loading for the longest usable product life; no color transfer to work Provides flexibility and resistance to tearing



NEW

MERIT PB273
GOOD CHOICE FOR SANDING PAINT, PRIMER, PLASTICS, FIBERGLASS, AND WHITEWOOD AT A LOW INITIAL PRICE

FEATURES	BENEFITS
<ul style="list-style-type: none"> P-graded, aluminum oxide abrasive Flexible latex B-wt. backing, with a full resin bond and open coat Water-based stearate, non-pigmented, No-Fil coating 	<ul style="list-style-type: none"> Fast cutting action and extended life with consistent finish Improved resistance to delamination; no delamination to back-up pad Can be used moist or wet Provides improved load resistance No color transfer to work



AVAILABILITY
STICK AND SAND (PSA)
DISC ROLLS
NON-VACUUM

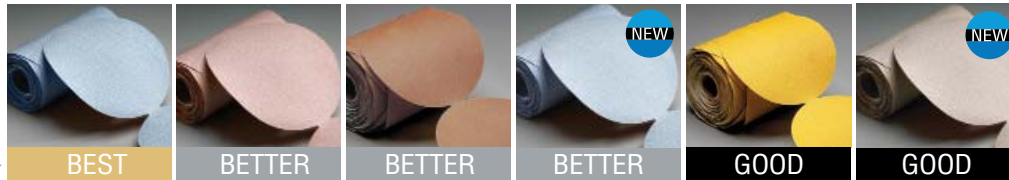

TIER:	BEST	BETTER	BETTER	BETTER	GOOD	GOOD
BRAND:	Norton	Norton	Norton	Norton	Norton	Merit
CAP CODE:	A975	A275	A270	A475	A290	PB273
ABRASIVE:	Ceramic Alumina	Aluminum Oxide	Aluminum Oxide	Silicon Carbide	Aluminum Oxide	Aluminum Oxide
PAPER BACKING WEIGHT:	Lightweight	Lightweight	Lightweight	Lightweight	Lightweight	Lightweight
OTHER:	P-Graded	P-Graded	P-Graded	P-Graded	P-Graded	P-Graded

SIZE	GRIT	ROLLS/ STD. PKG.	DISCS/ ROLL	PART NO.	PART NO.	PART NO.	PART NO.	PART NO.	PART NO.
3-1/2	80	4	100		66261136376				
	120			66261136375					
	180			66261136373					
	220			66261136372					
	320			66261136369					
	400			66261136368					
5	60	4	100					66261149831	
	80			66261140502	66261131464*		66254487415	66261149830	66623362930
	100			66261140501	66261131463*		66254487417	66261149829	66623371920
	120			66261140500	66261131462*		66254487418	66261149828	66623362929
	150			66261140499	66261131461*		66254487440	66261149827	66623362928
	180			66261140498	66261131460*		66254487441	66261149826	66623362927
	220			66261142474	66261131459*	66261127463	66254487442	66261149825	66623362926
	240			66261155380	66261131458*		66254487443	66261149824	66623362925
	280			66261155379	66261131457*			66261149823	
	320			66261155378	66261131456*	66261127465	66254487444	66261149822	66623362924
	400			66261155377	66261131454*	66261127466		66261149821	66623362923
	500				66261131453*	66261127467			
	600				66261131452*				66623362922
	800				66261131451*				66623362921
6	60	4	100					66261149847	
	80			66261140512	66261131481*		66254487446	66261149842	66623362940
	100			66261140511	66261131480*			66261149841	
	120			66261140510	66261131479*		66254487447	66261149840	66623362939
	150			66261140509	66261131478*			66261149839	66623362938
	180			66261140508	66261131477*		66254487448	66261149838	66623362937
	220			66261148340	66261131476*	66261127473	66254487449	66261149837	66623362936
	240			66261155376	66261131475*			66261149836	66623362935
	280			66261155375	66261131474*			66261149835	
	320			66261155374	66261131473*		66254487450	66261149834	66623362934
	360				66261141198*				
	400			66261155373	66261131471*			66261149833	66623362933
	500				66261131470*				
	600				66261131469*				66623362932
800		66261131468*				66623362931			
8	80	4	100		66261131617				
	120			66261131615					
	150			66261131614					
	180			66261131613					
	220			66261131612					
	320			66261131609					

* PACKAGING STANDARDS A275 = 6/100



PSA Disc Roll Dispenser

- Norton disc roll dispensers feature heavy-duty construction and a rubberized finish to protect your product, as well as the finish on your workpiece
- These versatile dispensers are designed to accommodate any 5" or 6" disc roll or sheet roll
- They can be attached to a wall or stacked for multi-grit or multi-diameter operations
- Discs are individually dispensed and removed from the roll by a cutter bar

DESCRIPTION	STD. PKG.	PART NO.
PSA DISC ROLL DISPENSER		
Single Disc Roll Dispenser	1	63642542772
Double Disc Roll Dispenser (shown)	1	63642502981

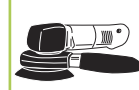

AVAILABILITY
STICK AND SAND (PSA)
DISC ROLLS
NON-VACUUM







TIER:	BEST	BETTER	BETTER
BRAND:	Norton	Norton	Norton
CAP CODE:	H920	H822	H875
ABRASIVE:	Ceramic Alumina	Zirconia Alumina	Zirconia Alumina
PAPER BACKING WEIGHT:	Heavyweight	Heavyweight	Heavyweight

SIZE	GRIT	ROLLS/ STD. PKG.	DISCS/ ROLL	PART NO.	PART NO.	PART NO.
5	60	4	100	66261149873	66261137310	
	80			66261149872	66261137309	66261124977
	100			66261149871	66261137308	66261125597
	120			66261149870	66261137307	
	150				66261137306	
6	60	4	100	66261149876	66261137323	
	80			66261149874	66261137322	66261125573
	120					
8	100	4	50	66261149879		
	120			4	100	66261137333

AVAILABILITY
STICK AND SAND (PSA)
DISC ROLLS – VACUUM



TIER:	BETTER	GOOD
BRAND:	Norton	Norton
CAP CODE:	A275	A290
ABRASIVE:	Aluminum Oxide	Aluminum Oxide
PAPER BACKING WEIGHT:	Lightweight	Lightweight
OTHER:	P-Graded	P-Graded

SIZE	GRIT	ROLLS/ STD. PKG.	DISCS/ ROLL	PART NO.	ROLLS/ STD. PKG.	DISCS/ ROLL	PART NO.
				 5 IN. X 5 HOLE DIE #3329			 5 IN. X 5 HOLE DIE #3329
5	60	6	100	66261131498	4	100	66261130266
	80			66261131497			66261130265
	100			66261131496			66261130264
	120			66261131495			66261130263
	150			66261131494			66261130262
	180			66261131493			66261130261
	220			66261131492			66261130260
	240			66261131490			66261130259
	320			66261131488			66261130258
	400			66261131487			
	500			66261131485			
				 6 IN. X 6 HOLE DIE #3333			 6 IN. X 6 HOLE DIE #3333
6	80	6	100	66261131515	4	100	66261130276
	100			66261131514			66261130275
	120			66261131513			66261130274
	150			66261131512			66261130273
	180			66261131511			66261130272
	220			66261131510			66261130271
	240			66261131509			
	280			66261131508			
	320			66261131507			66261130268
	400			66261131505			
600	66261131503						

Refer to the end of this section for back-up pads and accessories.

PAPER DISCS

MACHINES USED

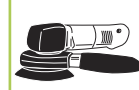

AVAILABILITY
HOOK AND LOOP
NON-VACUUM

BEST	BEST	BETTER	BETTER	BETTER	GOOD	GOOD
TIER:						
BRAND:	Norton	Norton	Norton	Norton	Merit	Norton
CAP CODE:	H920	A975	H875	A275	A475	PB273
ABRASIVE:	Ceramic Alumina	Ceramic Alumina	Zirconia Alumina	Aluminum Oxide	Silicon Carbide	Aluminum Oxide
PAPER BACKING WEIGHT:	Heavyweight	Lightweight	Heavyweight	Lightweight	Lightweight	Lightweight
OTHER:		P-Graded		P-Graded	P-Graded	P-Graded

SIZE	GRIT	MIN./ STD. PKG.	PART NO.	PART NO.	PART NO.	PART NO.	PART NO.	PART NO.	PART NO.
3	80	50/200				66261131532			
	100					66261144926			
	120					66261128688			
	150					66261140385			
	180					66261131528			
	220					66261131527			
	240					66261131526			
	320					66261131524			
	400					66261136995			
	500					66261131521			
	600					66261136996			
	800					66261131519			
	1000					66261135900			
	1500					66261147434			
5	40	25/100			66261125684				
	60	100/400	66261149864*						66261130224
	80		66261149865*	66261140522‡	66261125444•	66261131549	66623362950	66261149907	
	100		66261149866*	66261140521‡		66261131548	66623362788	66261149906	
	120		66261149867*	66261140520‡		66261131547	66623362949	66261149905	
	150			66261140519‡		66261131546	66623362948	66261149904	
	180			66261140518‡		66261131545	66623362947	66261149903	
	220			66261149541‡		66261131544	66623362946	66261149902	
	240					66261131543	66623362945		
	280					66261131542			
	320			66261149538‡		66261131541	66623362944	66261149900	
	400			66261149537‡		66261131539	66623362943	66261149899	
	500					66261131538	66261052270		
	600					66261131537	66254421221	66623362942	
	800					66261131536	66261052267	66623362941	
	1000					66261131535	66261052254		
	1200					66261131534			
	1500					66261131533			
6	36	25/100			66261123590				
	40				66261123589				
	80	100/400		66261140532‡	66261123588•	66261131566	66623362960	66261149916	
	100			66261140531‡		66261131565	66623365789	66261149915	
	120			66261140530‡		66261131564	66623362959	66261149914	
	150			66261140529‡		66261131563	66623362958	66261149913	
	180			66261140528‡		66261131562	66623362957	66261149912	
	220			66261149546‡		66261131561	66623362956	66261149911	
	240					66261131560	66623362955		
	280					66261131559		66261149910	
	320			66261149543‡		66261131558	66623362954	66261149909	
	400			66261149542‡		66261131556	66623362953	66261149908	
	500					66261131555	66261052269		
	600					66261131554		66623362952	
	800					66261131553	66261052268	66623362951	
	1000					66261131552	66261052255		
	1200					66261131551			
	1500					66261131550			
8	36	25/100			66261123593				
	40				66261123592				
	60	50/250	66261149894						
	80	25/100			66261123591				
	100	50/250	66261149896						
	120	100/400				66261131662			
	180					66261131661			

PACKAGING STANDARDS: MIN. / STD. PKG.

* H920 = 50/250

‡ A975, A975 VACUUM, A290 VACUUM = 50/200

• H875 = 25/100

Refer to the end of this section for back-up pads and accessories.

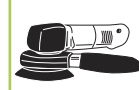

AVAILABILITY
HOOK AND LOOP
VACUUM

TIER:	BEST	BETTER	BETTER	GOOD	GOOD	GOOD
BRAND:	Norton	Norton	Norton	Norton	Norton	Merit
CAP CODE:	A975	H875	A275	A290	A290	PB273
ABRASIVE:	Ceramic Alumina	Zirconia Alumina	Aluminum Oxide	Aluminum Oxide	Aluminum Oxide	Aluminum Oxide
PAPER BACKING WEIGHT:	Lightweight	Heavyweight	Lightweight	Lightweight	Heavyweight	Lightweight
OTHER:	P-Graded		P-Graded	P-Graded	P-Graded	P-Graded

SIZE	GRIT	MIN./ STD. PKG.	PART NO.	PART NO.	PART NO.	PART NO.	PART NO.	PART NO.
			5 IN. X 5 HOLE DIE #3328		5 IN. X 5 HOLE DIE #3328	5 IN. X 5 HOLE DIE #3328	5 IN. X 8 HOLE DIE #3392	5 IN. X 8 HOLE DIE #3392
5	60	100/400				66261130236‡	66261130245‡	
	80		66261140517‡		66261131583	66261130235‡	66261130244‡	66623366071
	100				66261131582	66261130234‡	66261130243‡	
	120		66261140515‡		66261131581	66261130233‡	66261130242‡	66623369778
	150				66261131580	66261130232‡	66261130241‡	66623366073
	180				66261131579	66261130231‡	66261130240‡	66623366074
	220				66261131578	66261130230‡	66261130239‡	66623366075
	240				66261131577			
	280				66261131576			
	320				66261131575	66261130227‡	66261130238‡	66623366077
	400				66261131573	66261130226‡		
	600				66261131571			
			6 IN. X 6 HOLE DIE #3371		6 IN. X 6 HOLE DIE #3371	6 IN. X 6 HOLE DIE #3371		
6	80	100/400	66261140527‡		66261131600	66261130255‡		
	100		66261140526‡		66261131599			
	120				66261131598	66261130253‡		
	150				66261131597			
	180				66261131596			
	220				66261131595	66261130250‡		
	280				66261131593			
	320		66261149553‡		66261131592			
	400				66261131590			
	600				66261131588			
	800				66261131587			
			8 IN. X 8 HOLE DIE #3370					
8	36	25/100			66261123598			
	80				66261123596			

PACKAGING STANDARDS: ‡ A975 VACUUM, A290 VACUUM = 50/200

New for Fein/Festo Sanders

High-performance abrasives for high performance sanders. Now available: Norton SG A975 discs with center vacuum hole for Fein and Festo random orbital sanders.

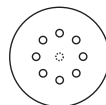

6 IN. X 9 HOLE
DIE #3408-2



BEST

TIER:	Norton
BRAND:	A975
ABRASIVE:	Ceramic Alumina
PAPER BACKING WEIGHT:	Lightweight
OTHER:	P-Graded

SIZE	GRIT	STD. PKG.	PART NO.
6	80	50/200	07660705489
	100		07660705488
	120		07660705487
	150		07660705486
	180		07660705485
	220		07660705484
	320		07660705483

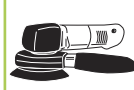

AVAILABILITY
INDIVIDUAL DISCS



TIER:	BETTER	BETTER	BETTER	GOOD	GOOD
BRAND:	Norton	Norton	Norton	Norton	Merit
CAP CODE:	H875	H875	A275	H290	PB273
ABRASIVE:	Zirconia Alumina	Zirconia Alumina	Aluminum Oxide	Aluminum Oxide	Aluminum Oxide
PAPER BACKING WEIGHT:	Heavyweight	Heavyweight	Lightweight	Heavyweight	Lightweight
FASTENING:	PSA	PSA Vacuum	PSA Tabbed	PSA	PSA Tabbed
OTHER:			P-Graded	P-Graded	P-Graded

SIZE	GRIT	MIN./ STD. PKG.	PART NO.	PART NO.	PART NO.	PART NO.	PART NO.
				<p>5" X 5 HOLE DIE #3328</p>			
5	36 40 80 100 120 150 180 220 240 320 400 600 800 1000 1200	50/200 100/400	66261125436 66261125307 66261125244	66261124919			69957348198‡ 69957348200 69957348201 69957348202 69957348203 69957348204 69957348205 69957348206 69957348207 69957348223 69957348224
				<p>6" X 6 HOLE DIE #3371</p>			
6	36 40 80 1000 1200 1500	50/200 100/400	66261123575 66261123574 66261123573	66261123580	66261131467 66261131466 66261131465	66261130834‡ 66261130833‡ 66261130832‡	
				<p>8" X 8 HOLE DIE #3370</p>			
8	36 40 80	25/100	66261123578 66261123577 66261123576	66261123584 66261123582		66261130827• 66261130826•	

PACKAGING STANDARDS:
MIN. / STD. PKG.
• H290 = 50/200
‡ H290 AND PB273 = 100/400

Refer to the end of this section for back-up pads and accessories.



FEATURED PRODUCTS



MULTI-AIR HOOK AND LOOP VACUUM
LESS DUST; MORE PRODUCTIVITY

FEATURES

- Revolutionary design for maximum vacuum assist
- Cutting surface of disc remains clean
- Highly-engineered back-up pad
- Unique SoftTouch discs on durable foam in fine grits

BENEFITS

- 30% increase in dust extraction; clogging is virtually eliminated
- Cleaner working environment; less dust and contamination
- 35% increase in productivity versus traditional vacuum systems
- No clogging; consistent cut throughout the life of the disc
- Revolutionary style for maximum dust extraction
- Sand over contours without cutting through
- Color-coded by grit size for easy identification

AVAILABILITY
HOOK AND LOOP
VACUUM

TIER:	BEST	BEST	BETTER	BETTER	BETTER	BETTER
BRAND:	Norton	Norton	Norton	Norton	Norton	Norton
CAP CODE:	A975	H835	A275	A270	A475	A275 SOFTTOUCH
ABRASIVE:	Ceramic Alumina	Zirconia Alumina	Aluminum Oxide	Aluminum Oxide	Silicon Carbide	Aluminum Oxide
OTHER:	P-Graded	P-Graded	P-Graded	P-Graded	P-Graded	P-Graded

SIZE	GRIT	MIN./STD. PKG.	PART NO.	PART NO.	PART NO.	PART NO.	PART NO.	PART NO.
5 x 11/16	80	100/400	63642563535					
	120		63642563536					
	150		63642563537					66254469673 NS
	180		63642563538					66254469674 NS
	220		63642563539					
	240		63642563540					
	280		63642563541 NS					
	320		63642563542			63642563520	66261071087 NS	
	360					63642563521 NS		
	400		63642563543			63642563522	66261029749 NS	
	500					63642563523	66261029750 NS	
	600					63642563524 NS	66254469392 NS	
	800					63642563525	66254412761 NS	
1000					66254476828 NS			
6 x 11/16	80	50/200	63642506243	66261181412				
	80	100/400			63642560561			
	100		66254412469 NS					
	120		63642506244*		63642560562 NS			
	150		63642506245*		63642560563		66254469675 NS	
	180		63642506246*		63642560564		66254469677 NS	
	220		63642506247*		63642560565			
	240		63642506248*		63642560566			
	280		63642506249*		63642560567			
	320		63642506250*		63642560568			
	360				63642560569 NS			
	400		63642506251*		63642560570		66261052264 NS	
	500		63642506252*		63642560571			
	600		63642506253*		63642560572		66254433565 NS	
	800		63642506254*		63642560573		66261052257 NS	
800	20/80						63642560577	
1000						66261052256 NS		
1000	20/80						63642560578	
1500							63642560579	
8 x 3/4	80	100/400	66254460398 NS		66254460406 NS			
	100		66254460399 NS		66254460407 NS			
	120		66254460400 NS		66254460408 NS			
	150		66254460401 NS		66254460410 NS			
	180		66254460403 NS		66254460412 NS			
	220		66254460404 NS		66254460413 NS			
	240		66254460405 NS		66254460414 NS			
	280				66254460415 NS			
	320				66254460416 NS			

PACKAGING STANDARDS: NS NON-STOCK: 5" AND 6" DISCS – MINIMUM QUANTITY = 2,000 DISCS, AND 8" DISCS – MINIMUM QUANTITY = 1,200 DISCS ,
*A975 6" DISCS: MIN./STD. PKG. - 50/200



NEW



Multi-Air Foam Interface Pads

- Allow sanding of contours and improve surface finish.
- Use with fine grit hook and loop Multi-Air sanding discs.
- Use with Multi-Air back-up pads.
- Not for use with Multi-Air SoftTouch discs.

DESCRIPTION	STD. PKG.	PART NO.
MULTI-AIR INTERFACE PADS		
5" Pad	16	63642585864
6" Pad	12	07660719359
8" Pad	10	07660782019

IMPROVED



Multi-Air Hook and Loop Back-up Pads with Vacuum Holes

- Multi-Air back-up pads are engineered to work as a system with our Multi-Air discs to enhance the performance of the discs by aligning with the discs' holes maximizing dust extraction and life of the discs.
- These pads are recommended for all Multi-Air applications.
- Pads have longer hooks for maximum hold.

DESCRIPTION	STD. PKG.	PART NO.
MULTI-AIR BACK-UP PADS WITH VACUUM HOLES		
5" (125mm) with 5/16"-24 Shank, Foam Laminate Pad	1	63642582249
6" (150mm) with 5/16"-24 Shank, Foam Laminate Pad	1	63642582245
6" (150mm) with 5/16"-24 Shank, Urethane Pad	1	63642506160
8" for Hutchins	10	66254425341

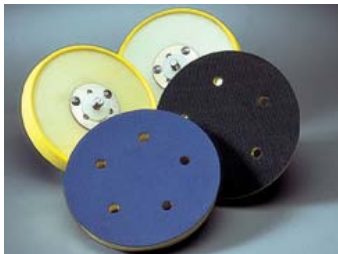

Low-Profile Pads for Dual Action / Random Orbital Sanders

- Soft density low-profile pads utilize 1/2" thick foam for fine finish sanding and offer moderate conformability.
- Medium low-profile pads have 1/2" thick urethane foam for intermediate and finish sanding.
- Firm density low-profile pads utilize 1/4" thick urethane foam for flash and seam removal.
- Available with PSA or hook and loop faces. Both designs are shock resistant and have a fiberglass backing plate with a riveted 5/16"-24 threaded shank for added strength and increased heat resistance.
- Available with standard hole patterns for vacuum-assist sanding.

DESCRIPTION	MAX. RPM	STD. PKG.	PART NO.
LOW PROFILE PADS FOR DA/RANDOM ORBITAL SANDERS			
3" Foam Polishing Pad		10	63642504295
3" Hook & Loop Soft Low-Profile	12,000	10*	63642506128
3" x 7/8" Hook & Loop Pad		10	63642541947
3-1/4" Hook & Loop Buffing Pad			66261085302
5" PSA Soft Low-Profile	12,000	5*	63642506126
5" PSA Medium Low-Profile	15,000	5*	63642506131
5" PSA Medium Low-Profile with 5 vacuum holes	15,000	5*	63642506132
5" Hook & Loop Soft Low-Profile	12,000	5*	63642506129
5" Hook & Loop Medium Low-Profile	15,000	5*	63642506135
5" Hook & Loop Medium Low-Profile with 5 vacuum holes	15,000	5*	63642506136
6" PSA Soft Low-Profile	12,000	5*	63642506127
6" PSA Medium Low-Profile	15,000	5*	63642506133
6" PSA Medium Low-Profile with 6 vacuum holes	15,000	5*	63642506134
6" Hook & Loop Soft Low-Profile	12,000	5*	63642506130
6" Hook & Loop Medium Low-Profile	15,000	5*	63642506137
6" Hook & Loop Medium Low-Profile with 6 vacuum holes	15,000	5*	63642506138
8" Hook & Loop Medium Low-Profile with 8 vacuum holes, 5 screw	1,500	5*	63642543712
8" Hook & Loop Medium Low-Profile with 8 vacuum holes, 6 screw	1,500	5*	63642543714

* PACKED IN INDIVIDUAL CLAMSHELL



Tapered Pads for Dual Action / Random Orbital Sanders

- Designed with medium density polyurethane foam and a tapered edge for conformability, these pads are firm enough for flat surfaces, yet soft enough for severe curves and contours.
- Available with either PSA (vinyl) or hook and loop faces in vacuum or non-vacuum.
- The 5" and 6" pads are shock resistant and have a fiberglass backing plate with a riveted 5/16"-24 threaded shank for use on random orbital or dual action sanders.
- The 8" pads have a 5/8"-11 threaded female hub.

DESCRIPTION	MAX. RPM	STD. PKG.	PART NO.
TAPERED PADS FOR DA/RANDOM ORBITAL SANDERS			
5" PSA Medium Tapered	15,000	5*	63642506139
5" PSA Medium Tapered with 5 vacuum holes	15,000	5*	63642506140
5" Hook & Loop Medium Tapered	15,000	5*	63642506143
5" Hook & Loop Medium Tapered with 5 vacuum holes	15,000	5*	63642506144
6" PSA Medium Tapered	15,000	5*	63642506141
6" PSA Medium Tapered with 6 vacuum holes	15,000	5*	63642506142
6" Hook & Loop Medium Tapered	15,000	5*	63642506145
6" Hook & Loop Medium Tapered with 6 vacuum holes	15,000	5*	63642506146
8" PSA Medium Tapered	6,000	5*	63642543112
8" Hook & Loop Medium Tapered	3,200	5*	63642543704

* PACKED IN INDIVIDUAL CLAMSHELL

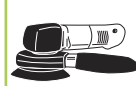

Hook & Loop Foam Interface Pads

- Designed for use with our fine grit hook and loop sanding discs.
- Improve both surface finish and cut rate.
- Use with hook and loop back-up pads.

DESCRIPTION	STD. PKG.	PART NO.
FOAM HOOK & LOOP INTERFACE PADS		
3" Diameter, 1/2" Thick Interface	10	63642505457
6" Diameter, 1/2" Thick Interface	5	63642542089
5" Diameter, 3/4" Thick Interface	2	63642502161
6" Diameter, 3/4" Thick Interface	2	63642502162



Half Moon Hand Pad

- The unique half moon pad uses a standard 5" hook and loop disc folded in half, which adheres to the hooks on the pad face.
- The straight edge of the pad allows the operator to sand corners, contours, narrow crevices and minute imperfections without over-sanding.

DESCRIPTION	STD. PKG.	PART NO.
HALF MOON HAND PAD		
5" Hook and Loop	10	63642502768



Polishing Adapter Pad

- Converts your standard hook and loop pad into a soft polishing pad.
- The foam adapter is 3/8" thick and is excellent for fine grits where minimal removal is required.
- It is ideal for either flat or contour surfaces.

DESCRIPTION	MAX. RPM	STD. PKG.	PART NO.
POLISHING ADAPTER PAD			
5" Hook and Loop Adapter Pad	3,786	10	63642503121



Ergonomic Hand Sanders

- The ergonomic palm sander is uniquely designed to be user-friendly, with finger indentations for the operator.
- It quickly converts standard 5" and 6" hook and loop discs into hand sanders for finishing flat surfaces.

DESCRIPTION	STD. PKG.	PART NO.
ERGONOMIC HAND SANDER		
5" Hook and Loop	5	63642503147
6" Hook and Loop	5	63642503726



Disc Hand Pads

- Hand pads eliminate finger sanding.
- The 1" thick pad is composed of two layers, neoprene and polyester foam, for excellent conformability and softness, resulting in fine finishes.
- The ultra-thin 3/16" thick pad is composed of a single layer of neoprene foam and is designed for maximum flexibility – producing excellent finishes.
- Each pad has an elastic hand strap to hold it firmly in place.
- Available with either PSA (vinyl) faces or hook and loop face.

DESCRIPTION	STD. PKG.	PART NO.
DISC HAND PADS		
5" x 3/16" Thick Soft Foam PSA	10	63642503111
5" x 1" Thick Soft Foam PSA	10	63642502842
5" x 1" Thick Soft Foam Hook and Loop	10	63642503117





CATEGORY DEFINITION

Norton PSA and Merit ShurStik PSA (pressure sensitive adhesive) individual cloth discs and disc rolls are used on three different types of machines and the application changes depending on which one they are used on.

- APPLICATIONS:**
- Pneumatic Die Grinders and Electric Random Orbital Sanders – for use on contours or flat surfaces for light- to medium-pressure grinding, blending, leveling, and finishing applications
 - Stationary Disc Sanders – used in woodworking and metalworking for stock removal, sanding/grinding flat surfaces, dimensioning and finishing
- SIZE RANGE:** 1/2" – 24" diameter
- GRIT RANGE:** 24 – 320
- ABRASIVE GRAIN:** Ceramic Alumina, Zirconia Alumina, Aluminum Oxide
- BACK-UP PADS:** Rubber, with hardness variations for different applications, for portable machines. Steel for stationary disc sanders



Small Diameter Cloth Discs for Pneumatic Die Grinders



AVAILABILITY

TIER:	GOOD
BRAND:	Merit
TRADENAME:	ShurStik
ABRASIVE:	Aluminum Oxide
ATTACHMENT:	PSA

GRIT	1/2"	3/4"	1"	1-1/2"	2"	3"	4"
24	-	-	08834172143	08834171143	08834171158	08834171173	08834171188
36	08834171100	08834171114	08834171129	08834171144	08834171159	08834171174	08834171189
40	08834171101	08834171115	08834171130	08834171145	08834171160	08834171175	08834171190
50	08834171102	08834171116	08834171131	08834171146	08834171161	08834171176	08834171191
60	08834171103	08834171117	08834171132	08834171147	08834171162	08834171177	08834171192
80	08834171104	08834171118	08834171133	08834171148	08834171163	08834171178	08834171193
100	08834171105	08834171119	08834171134	08834171149	08834171164	08834171179	08834171194
120	08834171106	08834171120	08834171135	08834171150	08834171165	08834171180	08834171195
150	08834171107	08834171121	08834171136	08834171151	08834171166	08834171181	08834171196
180	08834171108	08834171122	08834171137	08834171152	08834171167	08834171182	08834171197
240	08834171109	08834171123	08834171138	08834171153	08834171168	08834171183	08834171198
320	08834171110	08834171124	08834171139	08834171154	08834171169	08834171184	08834171199
QTY./ BOX	100	100	100	100	100	100	100
BACK-UP PADS	1/4" Shank 15,000 RPM 08834174096	1/4" Shank 15,000 RPM 08834174097	1/4" Shank 15,000 RPM 08834174098	1/4" Shank 15,000 RPM 08834174099	1/4" Shank 12,000 RPM 08834174100	1/4" Shank 10,000 RPM 08834174101	1/4" Shank 6,000 RPM 08834174102





Cloth PSA Discs for Random Orbital Sanders

FEATURED PRODUCTS



NORTON SG R938

BEST CHOICE FOR FLASH AND SEAM REMOVAL ON MOLDED PARTS AND A BROAD RANGE OF NONFERROUS METALWORKING AND WOODWORKING APPLICATIONS

FEATURES

- Patented, P-graded, Norton SG (ceramic alumina) grain
- All resin bond
- Strong, semi-flexible X-weight cotton cloth backing
- DL (dustless) anti-static
- Discs are tabbed

BENEFITS

- Maximum life; rapid, cool cutting; consistent finishes
- Provides excellent grain retention and load resistance
- Durable; resistant to heat
- Cleaner workpiece and equipment
- Easy application and removal

AVAILABILITY

TIER:	BEST		BEST		GOOD		GOOD	
BRAND:	Norton		Norton		Norton		Norton	
TRADENAME:	R980P		R938		Metalite R228		Metalite R228	
ABRASIVE:	Ceramic Alumina		Ceramic Alumina		Aluminum Oxide		Aluminum Oxide	
ATTACHMENT:	PSA Discs		PSA Tabbed Discs		PSA Discs		PSA Disc Roll	
OTHER:			P-Graded					

SIZE (D)	GRIT	MIN./ STD. PKG.	PART NO.	PART NO.	PART NO.	STD. PKG./ DISCS/ROLL	PART NO.
5"	36	50/250	66254461506		66261136589	4/100	66261133252
	40		66254461507		66261136588		
	50		66254461508		66261136587		
	60		66254461509		66261136586		
	80		66254461510		66261136585		
	100				66261139832		
	120				66261139833		
	150				66261139834		
	180		66254461512		66261136583		
	66261136582		66261136581				
6"	60	50/250			66261136596		
	80			66261136595			
	100			66261136594			
	120			66261136593			
	180			66261136592			
8"	36	50/250			66261136350		
	40			66261136351			
	50			66261136352			
	60			66261136576			
	80			66261136354			
	120			66261136355			

Back-up Pads for Cloth PSA Discs

DESCRIPTION	MAX. RPM	STD. PKG.	PART NO.
BACK-UP PADS FOR CLOTH PSA DISCS			
5" Diameter – Low Profile – Soft	12,000	5	63642503087
5" Diameter – Low Profile – Firm	12,000	5	63642503605
5" Diameter – Tapered – Medium	12,000	5	63642503112
6" Diameter – Tapered – Medium	10,000	5	63642543852
8" Diameter – Tapered – Medium	6,000	5	63642543112



Large Diameter Cloth PSA Discs

Used on stationary disc machines for dimensioning and finishing metal workpieces and woodworking. Pressure sensitive adhesive offers fast, convenient mounting. Made without center holes for full-face usage.



BLAZE R980P

BEST CHOICE FOR ALL HARD-TO-GRIND HIGH ALLOY STEELS

FEATURES

- Norton SG ceramic alumina abrasive
- Improved resin bond
- Self-lubricating supersize treatment
- Strong Y-weight. polyester backing

BENEFITS

- Coolest cut; significantly faster cut rate
- Better grain adhesion, edge-fray resistance
- Cool cut on harder-to-grind materials
- Long life and consistent cut



NORZON R821

BETTER CHOICE FOR GRINDING AND DEBURRING STAINLESS STEEL

FEATURES

- Self-sharpening, zirconia alumina abrasive
- Heavy Y-weight backing

BENEFITS

- Cooler cut, extended life over aluminum oxide discs
- Durable; reduced edge wear

AVAILABILITY

TIER:

TRADENAME:

ABRASIVE:

ATTACHMENT:

BETTER

BLAZE R980P

Ceramic Alumina

PSA

	10	12	16	18	20
WIDTH					
36		66254416171			66254416165
40		66254416172			66254416166
50		66254416173			66254416167
60		66254416174			66254416168
80		66254416175			66254416169
120		66254417176			66254417170
MIN./STD. PKG.		25/50			25/50

AVAILABILITY

TIER:

TRADENAME:

ABRASIVE:

ATTACHMENT:

BETTER

NORZON R821

Zirconia Alumina

PSA

	10	12	16	18	20
WIDTH					
24		66261138318			
36		66261138319		66261138337	66261138343
40	66261138314	66261138320			66261138344
50		66261138321	66261138333		
60	66261138316	66261138322	66261138334		66261138346
80	66261138317	66261138323	66261109128		
MIN./STD. PKG.	25/50	25/50	25/50	25/50	25/50

AVAILABILITY

TIER:

TRADENAME:

ABRASIVE:

ATTACHMENT:

GOOD

METALITE R228

Aluminum Oxide

PSA

	10	12	15	16	18	20	24
WIDTH							
36	66261136606	66261136635	66261136666	66261136700	66261136720	66261136710	66261136718
40	66261136604	66261136630	66261136665	66261136685		66261136709	66261136717
50	66261136607	66261136625	66261136714	66261136684		66261136711	66261136725
60	66261136602	66261136620	66261136663	66261136683	66261136696	66261136712	66261136726
80	66261136601	66261136615	66261136662	66261136701	66261136723	66261136706	66261136727
100	66261136600	66261136614					
120		66261136613					
MIN./STD. PKG.	25/50	25/50	25/50	25/50	25/50	25/50	10/10



CATEGORY DEFINITION

Norton flexible diamond products combine the durability and aggressiveness of diamond, on a flexible backing.

- APPLICATIONS: Grinding ceramic, glass, composites, carbide and ceramic coatings, fiberglass, and reinforced plastics. Removing rust and scale on other materials. Producing metallurgical stamps and coupons.
- SIZE RANGE: PSA Discs: 2" – 8"
Quick Change TR (Type III): 2" and 3"
- GRIT RANGE: 60 – 1800
- ABRASIVE TYPES: Diamond
- BACKING COLOR: Color-coded backings for easily distinguished grit size selection



FEATURED PRODUCTS



FLEXIBLE DIAMOND PSA DISCS

BETTER CHOICE FOR GRINDING GLASS, CERAMICS AND COMPOSITES, REMOVING RUST AND SCALE, AND PRODUCING METALLURGICAL STAMPS AND COUPONS

FEATURES

- Diamond
- PSA backing

BENEFITS

- Facilitates fast stock removal
- Quick and easy mounting and removal

			TIER: BETTER		
SIZE (D X H)	COLOR	GRIT	STD. PKG.	PRODUCT NO.	PART NO.
FLEXIBLE DIAMOND PSA DISCS					
2" x no hole	Green	60	1	FDD2P60	66260308159
	Black	120	1	FDD2P120	66260307722
	Red	200	1	FDD2P200	66260307723
	Yellow	400	1	FDD2P400	66260308160
	White	800	1	FDD2P800	66260307012
5" x no hole	Green	60	1	FDD5P60	66260307839
	Black	120	1	FDD5P120	66260307838
	Red	200	1	FDD5P200	66260307019
	Yellow	400	1	FDD5P400	66260307960

SEE COATED ABRASIVE CLOTH PSA DISC SECTION FOR BACK-UP PADS.

			TIER: BETTER		
SIZE (D X H)	COLOR	GRIT	STD. PKG.	PRODUCT NO.	PART NO.
FLEXIBLE DIAMOND PSA DISCS					
6" x no hole	Green	60	1	FDD6P60	66260306381
	Black	120	1	FDD6P120	66260306382
	Red	200	1	FDD6P200	66260306383
	Yellow	400	1	FDD6P400	66260308161
8" x No Hole	Green	60	1	FDD8P60	66260306389
	Black	120	1	FDD8P120	66260306387
	Red	200	1	FDD8P200	66260306388
	Yellow	400	1	FDD8P400	66260311769
	White	800	1	FDD8P800	66260306386
	Blue	1800	1	FDD8P1800	66260306390



FLEXIBLE DIAMOND QUICK-CHANGE TR (TYPE III) DISCS

BETTER CHOICE FOR IMPROVED CUT RATE AND FINISH ON CERAMICS, GLASS, FIBERGLASS, COMPOSITES, CARBIDE, AND OTHER TOUGH METALS AND COATINGS

FEATURES

- Unique abrasive pattern
- TR (Type III) fastener

BENEFITS

- Increased aggressiveness, durability and lower costs versus standard diamond discs
- Rapid, tool-free disc changes mean maximum grind time
- Discs stay firmly locked to back-up pad when in use

			TIER: BETTER		
SIZE (D)	COLOR	GRIT	STD. PKG.	PRODUCT NO.	PART NO.
TR (TYPE III) DIAMOND DISCS					
2"	Green	60	12	FDD2SL60	66260311778
	Black	120	12	FDD2SL120	66260311779
	Red	200	12	FDD2SL200	66260311780
	Yellow	400	12	FDD2SL400	66260311781
	White	800	12	FDD2SL800	66260311782

SEE COATED ABRASIVE QUICK-CHANGE DISC SECTION FOR BACK-UP PADS.

			TIER: BETTER		
SIZE (D)	COLOR	GRIT	STD. PKG.	PRODUCT NO.	PART NO.
TR (TYPE III) DIAMOND DISCS					
3"	Green	60	12	FDD3SL60	66260311783
	Black	120	12	FDD3SL120	66260311784
	Red	200	12	FDD3SL200	66260311785
	Yellow	400	12	FDD3SL400	66260311786
	White	800	12	FDD3SL800	66260311787



**NORTON SG
BLAZE**

**Norton
BLUEFIRE™**

MERIT



CATEGORY DEFINITION

Tool-free, twist-on and -off fastening systems make fast work of disc changes to maximize productivity by minimizing downtime.

- APPLICATIONS:** Mini flap, fiber, and trimmable hard plastic discs: welding grinding and blending; heavy metal removal; light deburring and finishing
Cloth discs: light- to medium-pressure grinding; blending, leveling, and finishing applications; for use on contours or flat surfaces
- SIZE RANGE:** 9/16" – 4" diameter
- GRIT RANGE:** 24 – 320
- ABRASIVE GRAIN:** Ceramic Alumina, Zirconia Alumina, Aluminum Oxide, Silicon Carbide
- BACKING:** Fiber or cloth
- CLOTH FLEX:** 3-ply (more aggressive), 2-ply (standard), or fx (more flexible) lamination
- ATTACHMENT:** Type TS (II), Type TR (III), and Type TP (I)
- BACK-UP PADS:** Rubber with hardness variations for different applications

COATED ABRASIVE QUICK-CHANGE DISC AVAILABILITY



Fiber

- The most heavy-duty discs with resin over resin construction on heavy-duty vulcanized fiber backing. Premium grain for applications from heavy stock removal to surface blending



NorKut

- Unique polymer backing resists cracking and breakage and can be cut down to the 1" core. Use the cores to grind "pinch" welds and other hard-to-reach areas.



Mini Flap

- Layered flaps wear away evenly, producing an aggressive cutting action while also providing blending capabilities



Cloth 3-Ply

- These heavy-duty, 3-ply polyester laminate construction discs are the most aggressive and durable cloth discs on the market



Cloth 2-Ply

- Our standard 2-ply laminate construction creates an aggressive and durable cloth disc for flat surfaces



Cloth Flexible (fx)

- Offer a flexible, 2-ply cotton laminate construction for added conformability on contoured surfaces or any application where added flexibility is needed

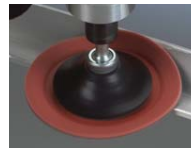

Cloth FlexEdge

- Manufactured with an abrasive cloth where the outer 3/8" is more flexible than the rest of the disc; designed to avoid gouging on contoured surfaces or soft materials

QUICK-CHANGE ATTACHMENT SYSTEMS AND CROSS REFERENCE GUIDE

Type TS (Type II)

- Features a turn-on/turn-off style fastener
- Fastener is made of metal
- Equivalent to Standard Abrasives' SocAtt® locking system



Type TR (Type III)

- Features a roll-on/roll-off style fastener
- Fastener is made of plastic
- Equivalent to 3M™ Roloc™ fastening system



Type TP (Type I)

- Snap-on/snap-off system which enables you to change discs quickly and safely, reducing downtime and operating expenses
- Fastener is made of nylon



MERIT

Type II

Type III

Type I

NORTON

TS

TR

TP

3M	Roloc TS/TSM	Roloc TR	Roloc TP
Standard	TS (SocAtt)	TR (Lockit)	TP (ClickOn)
Superior	Type S	Type R	–
Arc	Type S	Type R	Type P
Pferd	Type CD	Type CDR	–
Sait	SAIT-LOK	SAIT-LOK-R	–
Camel	Turn On	Roll On	–
Klingspor	QMC	QRC	–
Garryson	Type S	Type R	–



MATERIAL/APPLICATION-TO-PRODUCT RECOMMENDATION GUIDE

	BEST HIGHEST PRODUCTIVITY LOWEST TOTAL COST	BETTER EXCELLENT BLEND OF PERFORMANCE & PRICE	GOOD CONSISTENT PERFORMANCE LOW INITIAL PRICE
Stainless Steel / Titanium / Super Alloys	Norton SG Blaze Plus R980P	Merit Zirc Plus	Merit ALO Plus
Mild Carbon Steel / Welds	Merit Ceramic Plus	NorZon BlueFire R884	Merit ALO
Ferrous Metals / Cast Iron	Merit Ceramic Plus	NorZon BlueFire R884	Merit ALO
Brass / Bronze / Aluminum	–	NorZon BlueFire R884	Merit ALO
Paint / Glue / Adhesive	–	–	Merit ALO
Concrete / Stone / Fiberglass	–	–	Merit Silicon Carbide

APPLICATION/GRIT RECOMMENDATION GUIDE

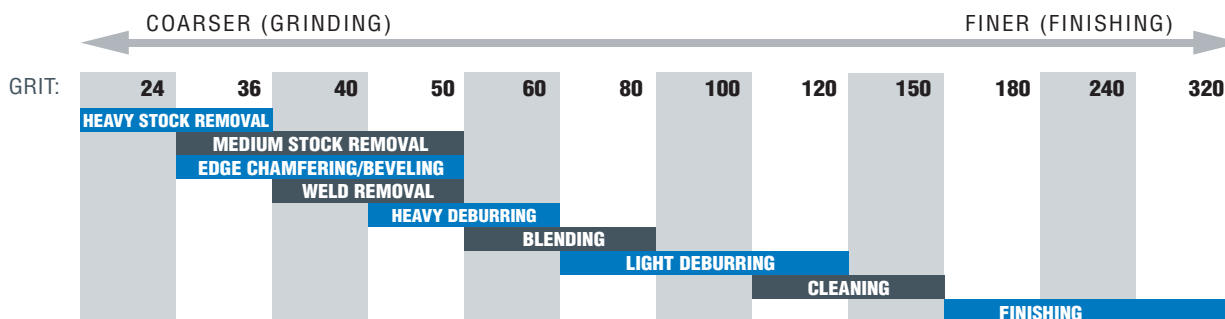

CROSS REFERENCE GUIDE

Abrasive	TOTAL PERFORMANCE						INITIAL PRICE		
	BEST		BETTER				GOOD		
Backing	Ceramic Alumina Full Ratio	Ceramic Alumina Full Ratio	Zirconia Alumina	Zirconia Alumina	Zirconia Alumina	Zirconia Alumina	Aluminum Oxide	Aluminum Oxide	Silicon Carbide
	Fiber	Cloth	Fiber	Flap	Cloth	Cloth	Cloth	Cloth	Cloth
MERIT	Ceramic Plus	Ceramic Plus	Zirconia	Zirc	Zirc Plus	Zirc	ALO Plus	ALO	Silicon Carbide
NORTON	SG Blaze F980	SG Blaze R980P	–	–	–	NorZon BlueFire R884	–	Metalite R228	–
3M	983C, 988C	963G, 977F, 785C, 777F	501C	–	–	–	–	361F	461F
Standard	–	Ceramic Pro, Ceramic	–	–	Zirconia Pro	Zirconia	A/O Extra, A/O Pro	A/O	Silicon Carbide
Superior	–	Ceramic G.A.	Zirc	–	Zirc w/ Grinding Aid	Premium Zirc	A/O w/ Grinding Aid	Premium A/O, Rigid Kut A/O	–
Arc	–	–	–	–	Zirconia/Y Plus	Zirconia/Y Standard	A/O/X Plus Coolant	A/O/Y Premium	–
Pferd	Ceramic Oxide CO	Ceramic Oxide CO	–	Zirconia Alumina Z	–	ZA Z	Aluminum Oxide A-Plus, Aluminum Oxide A-INOX-FORTE	Aluminum Oxide A, A/O A-FORTE	Silicon Carbide SiC
Sait	–	–	–	–	3Z, Z-H	Z	3A	2A-H, 2A	–
Camel	–	–	–	–	Zirconia AO w/ Grinding Aid	Zirconia AO	–	Aluminum Oxide	–
Klingspor	–	Ceramic	–	–	Alumina Zirconia-Lubricated	Alumina Zirconia	–	Aluminum Oxide	–
Garryson	–	Ceramic	–	–	Zirconia AO w/ Grinding Aid	–	–	Aluminum Oxide	–



Norton SG Blaze F980 Ceramic Fiber Discs

- Norton SG ceramic grain with self-lubricating, supersize treatment provides coolest cut; significantly faster cut rates
- Heaviest fiber backing, greater durability, longest life, and edge-fray resistance on tough applications and stainless steel



Merit Ceramic Plus Fiber Discs

- Ceramic alumina grain with self-lubricating supersize treatment, resin fiber discs resist heat build-up, cut aggressively, and are perfect for those applications that require a firm aggressive disc
- Heaviest fiber backing, greater durability, longest life, and edge-fray resistance on tough applications and stainless steel



Merit Zirconia Fiber Discs

- New, improved zirconia alumina provides a constant supply of sharp cutting edges for a fast, aggressive cutting action
- Heaviest fiber backing, greater durability, longer life, and edge fray resistance on tough applications and stainless steel

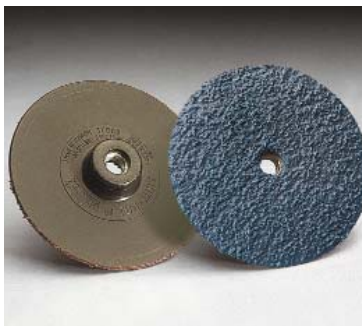

Norton NorKut Discs

- NorZon grain is resin bonded to a unique polymer backing which resists cracking and breaking and can be trimmed to the 1" core
- Use the cores to grind "pinch" welds and other hard-to-reach areas
- Used with a quick change mandrel: 7/16"-20 threaded for hand-held pneumatic grinders or 1/4" mandrel for automotive drills

AVAILABILITY

TIER:	BEST
BRAND:	Norton
ABRASIVE:	Ceramic Alumina
BACKING:	Fiber – Heavy Duty
OTHER:	Supersized
ATTACHMENT:	TR (Type III)



SIZE (D)	GRIT	STD. PKG.	PART NO.
2	36	25	66261058704
	50	25	66261058705
	60	25	66261058706
	80	25	66261058707
3	36	25	66261058708
	50	25	66261058709
	60	25	66261058711
	80	25	66261058712

AVAILABILITY

TIER:	BEST	BEST
BRAND:	Merit	Merit
ABRASIVE:	Ceramic Alumina	Ceramic Alumina
BACKING:	Fiber – Heavy Duty	Fiber – Heavy Duty
OTHER:	Supersized	Supersized
ATTACHMENT:	TS (Type II)	TR (Type III)



SIZE (D)	GRIT	STD. PKG.	PART NO.	PART NO.
2	36	100	08834165611	08834166041
	50		08834165613	08834166043
	60		08834166226	08834166044
	80		08834166227	08834166045
	120		08834165616	08834166046
3	36	50	08834166035	08834166219
	50		08834166037	08834166220
	60		08834166038	08834166221
	80		08834166039	08834166222
	120		08834166040	08834166223

AVAILABILITY

TIER:	BETTER	BETTER
BRAND:	Merit	Merit
ABRASIVE:	Zirconia Alumina	Zirconia Alumina
BACKING:	Fiber – Heavy Duty	Fiber – Heavy Duty
ATTACHMENT:	TS (Type II)	TR (Type III)



SIZE (D)	GRIT	STD. PKG.	PART NO.	PART NO.
2	36	100	08834167800	08834167810
	50		08834167802	08834167812
	60		08834167803	08834167813
	80		08834167804	08834167815
3	36	50	08834167805	08834167816
	50		08834167807	08834167818
	60		08834167806	08834167819
	80		08834167809	08834167820

AVAILABILITY

TIER:	BETTER
BRAND:	Norton
ABRASIVE:	Zirconia Alumina
BACKING:	Extra HD Polymer
ATTACHMENT:	Threaded Hole

SIZE (D)	GRIT	STD. PKG.	PART NO.
3	24	20	63642503656
	36		63642503657
	50		63642503658
7/16"-20 Mandrel		5	63642503659
1/4" Mandrel		5	63642503660



Merit Mini Zirconia Flap Discs

- High performance zirconia alumina abrasive provides maximum cut rate and life
- Layered flaps wear away evenly, producing a high-quality and consistent finish

AVAILABILITY

TIER:	BETTER	BETTER
BRAND:	Merit	Merit
ABRASIVE:	Zirconia Alumina	Zirconia Alumina
FLAP:	Cotton	Cotton
BACKING MATERIAL:	X-Heavy Duty Plastic	X-Heavy Duty Plastic
ATTACHMENT:	TS (Type II)	TR (Type III)



SIZE (D)	GRIT	STD. PKG.	PART NO.	PART NO.
2	36	10	08834195020	08834194550
	40		08834195021	08834194551
	60		08834195022	08834194552
	80		08834195023	08834194553
	120		08834195024	08834194554
3	36	10	08834195035	08834194563
	40		08834195036	08834194564
	60		08834195037	08834194565
	80		08834195038	08834194566
	120		08834195039	08834194567

DESCRIPTION	STD. PKG.	PART NO.
Mini Flap Disc 2" & 3" TS (Type II) Back-up Pad	1	08834168539
Mini Flap Disc 2" & 3" TR (Type III) Back-up Pad	1	08834160172

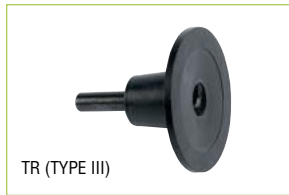

Norton SG Blaze R980P Cloth Discs

- Next-generation, Norton SG ceramic alumina grain with self-lubricating, supersize treatment provides coolest cut; significantly faster cut rates
- 3-ply heavy-duty laminate discs (Y-wt. polyester yellow backing) are more aggressive; for greatest durability, longest life, and edge-fray resistance on tough applications and stainless steel
- 2-ply laminate discs (red backing) provide durability and long life, but are more conformable and flexible

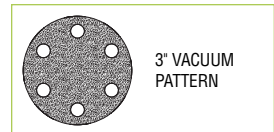
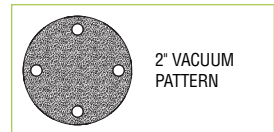

AVAILABILITY



TIER:	BEST	BEST	BEST	BEST	BEST
BRAND:	Norton	Norton	Norton	Norton	Norton
ABRASIVE:	Ceramic Alumina	Ceramic Alumina	Ceramic Alumina	Ceramic Alumina	Ceramic Alumina
BACKING:	Polyester Heavy Duty	Polyester Conformable	Polyester Heavy Duty	Polyester Heavy-Duty Vacuum	Polyester Conformable
OTHER:	Supersized	Supersized	Supersized	Supersized	Supersized
ATTACHMENT:	TS (Type II)	TS (Type II)	TR (Type III)	TR (Type III)	TR (Type III)

SIZE (D)	GRIT	STD. PKG.	PART NO.	PART NO.	PART NO.	PART NO.	PART NO.
1-1/2	36	100	66261162307	63642595401	66261162308		63642595465
	50		66261162309	63642595446	66261162310		63642595467
	60		66261162311	63642595447	66261162312		63642595468
	80		66261162313	63642595450	66261162314		63642595469
	120		66261043379	66261043416	66261043380		66261043417
2	36	25	66261162317	63642595452	66261162318		63642595470
	50		66261162319	63642595456	66261162320		63642595472
	60		66261162321	63642595458	66261162322	66254481589	63642595476
	80		66261162323	63642595459	66261162324	66254481590	63642595478
	100		66261043382	66261043418	66261043383		66261043419
	120		66261043384	66261043420	66261043386	66254481591	66261043421
3	36	25	66261162327	63642595460	66261162328		63642595479
	50		66261162329	63642595462	66261162330		63642595480
	60		66261162331	63642595463	66261162332	66254481705	63642595481
	80		66261162333	63642595464	66261162334	66254481707	63642595493
	100		66261043389	66261043422	66261043390		66261043423
	120		66261043391	66261043424	66261043392	66254481708	66261043425



Merit Ceramic Plus Cloth Discs

AVAILABILITY

TIER:	BEST	BEST	BEST
BRAND:	Merit	Merit	Merit
ABRASIVE:	Ceramic Alumina	Ceramic Alumina	Ceramic Alumina
BACKING:	Polyester Standard	Polyester Standard	Polyester Standard
OTHER:	Supersized	Supersized	Supersized
ATTACHMENT:	TS (Type II) 	TR (Type III) 	TP (Type I) 



- Ceramic alumina grain provides exceptional life and value, especially on hard-to-grind alloys
- The supersize grinding aid produces longer life and cooler cut
- Strong, Y-wt. 2-ply polyester backing provides excellent durability and grain adhesion

SIZE (D)	GRIT	STD. PKG.	PART NO.	PART NO.	PART NO.
9/16	36	100	08834163315		08834163000
	40		08834163316		08834163003
	50		08834163317		08834163004
	60		08834163318		08834163005
	80		08834163319		08834163014
	100		08834163434		08834163433
	120		08834163320		08834163017
3/4	36	100	08834163321	08834163392	08834163020
	40		08834163322	08834163393	08834163021
	50		08834163324	08834163394	08834163022
	60		08834162239	08834163395	08834163023
	80		08834163339	08834163396	08834163024
	100		66254410755	08834163438	08834163436
	120		08834163362	08834163397	08834163027
1	36	100	08834163374	08834163398	08834163028
	40		08834163375	08834163400	08834163030
	50		08834163376	08834163401	08834163031
	60		08834162240	08834163402	08834163042
	80		08834163378	08834163403	08834163043
	100		08834163440	08834163441	08834163439
	120		08834163379	08834163404	08834163112
1-1/2	36	100	08834163421	08834163405	08834163113
	40		08834163380	08834163406	08834163114
	50		08834163252	08834162620	08834163115
	60		08834160463	08834163407	08834163116
	80		08834163273	08834163408	08834163117
	100		08834163443	08834163444	08834163442
	120		08834168653	08834163409	08834168650
2	36	100	08834163118	08834160449	08834163119
	40		08834163229	08834163410	08834163120
	50		08834163259	08834163411	08834163121
	60		08834163551	08834163412	08834163231
	80		08834163381	08834165615	08834163219
	100		08834163446	08834163447	08834163445
	120		08834163382	08834168657	08834168651
3	36	50	08834163383	08834160458	08834163238
	40	08834163384	08834163413	08834163245	
	50	100	08834163385	08834163414	08834168275
	60	08834163386	08834163415	08834163266	
	80	08834163387	08834168178	08834169701	
	100	08834163449	08834163450	08834163448	
	120	08834168655	08834168658	08834168652	
4	36	50	08834162742	08834163416	08834163280
	40		08834163388	08834163417	08834163287
	50		08834162743	08834163418	08834163294
	60		08834163389	08834162992	08834163301
	80		08834163390	08834163419	08834163308
	100		08834163452	08834163453	08834163451
	120		08834163391	08834163420	08834163314



Merit Zirconia Plus Cloth Discs

AVAILABILITY

TIER:	BETTER	BETTER	BETTER
BRAND:	Merit	Merit	Merit
ABRASIVE:	Zirconia Alumina	Zirconia Alumina	Zirconia Alumina
BACKING:	Polyester Standard	Polyester Standard	Polyester Standard
OTHER:	Supersized	Supersized	Supersized
ATTACHMENT:	TS (Type II) 	TR (Type III) 	TP (Type I) 



SIZE (D)	GRIT	STD. PKG.	PART NO.	PART NO.	PART NO.
1	36	100	08834167051	08834167093	08834167009
	40		08834167052	08834167094	08834167010
	50		08834167053	08834167095	08834167011
	60		08834167054	08834167096	08834167012
	80		08834167055	08834167097	08834167013
1-1/2	36	100	08834167058	08834167100	08834167016
	40		08834167059	08834167101	08834167017
	50		08834167060	08834167102	08834167018
	60		08834167061	08834167103	08834167019
	80		08834167062	08834167104	08834167020
2	36	100	08834167065	08834167107	08834167023
	40		08834167066	08834167108	08834167024
	50		08834165583	08834167109	08834167025
	60		08834167068	08834167110	08834167026
	80		08834167069	08834167111	08834167027
3	36	50	08834167072	08834167114	08834167030
	40		08834167073	08834167115	08834167031
	50		08834167074	08834167116	08834167032
	60		08834167075	08834167117	08834167033
	80		08834167076	08834167118	08834167034
4	36	50	08834167079	08834167121	08834167037
	40		08834167080	08834167122	08834167038
	50		08834167081	08834167123	08834167039
	60		08834167082	08834167124	08834167040
	80		08834167083	08834167125	08834167041
	120		08834167085	08834167127	08834167043

- Ideal product for demanding grinding applications
- Grinding aid results in cooler cut on stainless steel, titanium and other exotic alloys
- Strong, Y-wt., 2-ply polyester backing provides excellent durability and grain adhesion
- Lubricated supersize coat runs cooler



Norton NorZon BlueFire R884 Cloth Discs NEW

AVAILABILITY

TIER:	BETTER	BETTER
BRAND:	Norton	Norton
ABRASIVE:	Zirconia Alumina	Zirconia Alumina
BACKING:	Polyester Standard	Polyester Standard
ATTACHMENT:	TS (Type II) 	TR (Type III) 

- Premium, versatile, self-sharpening zirconia alumina plus grain provides aggressive cut and up to 30% longer life than competitive zirconia alumina products
- Upgraded resin bond improves base adhesion and reduces grain shedding
- New grain coating results in longer life and faster cut rate
- Semi-open coat retards loading on soft metals (aluminum, brass, and bronze) and wood, as well as stainless steel and carbon steel
- Durable, Y-wt, 2-ply polyester backing stands up to demanding applications: high-pressure and hard-to-grind exotic alloys

SIZE (D)	GRIT	STD. PKG.	PART NO.	PART NO.
1	50	100	66261138609	
	60		66261138608	
	80		66261138607	
1-1/2	24	100	66261138625	
	36		66261138624	66261121041
	50		66261138622	
	60		66261138621	66261121043
	80		66261138620	66261121044
2	24	25	66261138638	66261138672
	36		66261138637	66261138671
	50		66261138635	66261138670
	60		66261138634	66261121048
	80		66261138633	66261121049
3	24	25	66261138665	66261138675
	36		66261138664	66261138674
	50		66261138662	66261138673
	60		66261138661	66261121053
	80		66261138660	66261121054
4	36	25	66261138683	
	50		66261138681	
	60		66261137343	
	60		66261137343	
	80		66261138679	

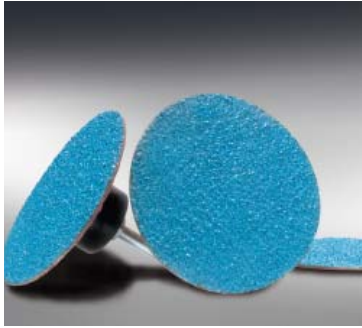

Merit Zirconia Cloth Discs

- Self-sharpening, zirconia alumina abrasive provides cooler cut, longer life
- Strong, Y-wt., 2-ply cotton backing construction for extended durability and reduced edge-wear

AVAILABILITY

TIER:	BETTER	BETTER	BETTER
BRAND:	Merit	Merit	Merit
ABRASIVE:	Zirconia Alumina	Zirconia Alumina	Zirconia Alumina
BACKING:	Cotton Standard	Cotton Standard	Cotton Standard
ATTACHMENT:	TS (Type II)	TR (Type III)	TP (Type I)

SIZE (D)	GRIT	STD. PKG.	PART NO.	PART NO.	PART NO.
1	40	100	08834165327	08834164591	08834166129
	50		08834164590	08834164596	08834166130
	60		08834165329	08834164597	08834166131
	80		08834165330	08834164304	08834166132
1-1/2	36	100	08834165341	08834166263	08834161366
	40		08834165342	08834164598	08834166162
	50		08834165343	08834166971	08834161480
	60		08834165344	08834164599	08834161118
	80		08834165345	08834161688	08834166190
2	36	100	08834165356	08834164208	08834166134
	40		08834165357	08834164600	08834166135
	50		08834165358	08834161534	08834166136
	60		08834165359	08834161116	08834166137
	80		08834165360	08834166198	08834166138
3	36	50	08834165371	08834166264	08834166140
	40		08834165372	08834164862	08834166141
	50		08834165373	08834161535	08834166142
	60		08834165374	08834166259	08834166143
	80		08834165375	08834166269	08834166144



Non-Woven Discs

Merit and Norton non-woven quick-change discs are a combination of strong synthetic mesh and quality abrasives, bonded together by a smear-resistant adhesive. They are ideal for use on portable tools to clean and remove imperfections on metal surfaces, clean, deburr or finish a variety of surfaces, blend weld seams, or create decorative finishes. The open construction of the non-woven material enables aggressive cutting action and improved surface finish while maintaining its non-loading feature.



See Non-Woven Discs section for full product listing and application information.



Merit Aluminum Oxide Plus Cloth Discs

- Aluminum Oxide Plus discs feature a grinding aid
- They run cooler and more efficiently for grinding exotic alloys
- Strong, Y-wt., 2-ply polyester backing construction for extended durability and reduced edge-wear

AVAILABILITY

TIER:	GOOD	GOOD	GOOD
BRAND:	Merit	Merit	Merit
ABRASIVE:	Aluminum Oxide	Aluminum Oxide	Aluminum Oxide
BACKING:	Polyester Standard	Polyester Standard	Polyester Standard
OTHER:	Supersized	Supersized	Supersized
ATTACHMENT:	TS (Type II) 	TR (Type III) 	TP (Type I) 

SIZE (D)	GRIT	STD. PKG.	PART NO.	PART NO.	PART NO.
3/4	36	100	08834167462	08834164467	08834164345
	40		08834167463	08834164468	08834164346
	50		08834167464	08834164469	08834164347
	60		08834167465	08834164470	08834164349
	80		08834167466	08834164471	08834164350
1	120		08834167468	08834164473	08834164361
	36	100	08834167477	08834164475	08834164363
	40		08834167478	08834164476	08834164364
	50		08834167479	08834164477	08834164365
	60		08834167480	08834164478	08834164366
80	08834167481		08834164479	08834164368	
1-1/2	120		08834167483	08834164481	08834164370
	36	100	08834166881	08834164483	08834164392
	40		08834166882	08834164484	08834164393
	50		08834166883	08834164485	08834164394
	60		08834166884	08834164486	08834164395
80	08834166885		08834164487	08834164396	
2	120		08834166887	08834164489	08834164398
	36	100	08834166896	08834164491	08834164400
	40		08834166897	08834164492	08834164401
	50		08834166898	08834164493	08834164402
	60		08834166899	08834164494	08834164403
80	08834166900		08834164495	08834164404	
3	120		08834166902	08834164496	08834164428
	36	50	08834166911	08834164498	08834164430
	40		08834166912	08834164499	08834164431
	50		08834166913	08834164500	08834164432
	60		08834166914	08834164501	08834164433
80	08834166915		08834164502	08834164434	
4	120		08834166917	08834164509	08834164436
	36	50	08834163959	08834164511	08834164459
	40		08834163960	08834164525	08834164460
	50		08834163961	08834164526	08834164461
	60		08834163962	08834164527	08834164462
80	08834163963		08834164536	08834164463	
	120		08834163965	08834164542	08834164465





Merit Metal Aluminum Oxide Cloth Discs



- Versatile aluminum oxide abrasive is tough and durable with aggressive cutting action
- Heavyweight, but smooth, cotton backing for roughing and blending
- Available in coarse grits for light to medium grinding, medium grits for blending, and fine finishing grits
- Competitive initial price point makes this product the best starting specification for end-users unable to measure performance

AVAILABILITY



TIER:	GOOD	GOOD
BRAND:	Merit	Merit
ABRASIVE:	Aluminum Oxide	Aluminum Oxide
BACKING:	Cotton Standard	Cotton Standard
ATTACHMENT:	TS (Type II) 	TR (Type III) 

SIZE (D)	GRIT	STD. PKG.	PART NO.	PART NO.
2	36	100	66254468890	66254469256
	40		66254468891	66254469257
	50		66254469251	66254469258
	60		66254469252	66254469259
	80		66254469253	66254469260
	100		66254469254	66254469261
3	120		66254469255	66254469262
	36	50	66254469263	66254469270
	40		66254469264	66254469271
	50		66254469265	66254469272
	60		66254469266	66254469273
	80		66254469267	66254469274
100	66254469268		66254469275	
	120		66254469269	66254469276



**Norton Metalite R228
Aluminum Oxide Cloth Discs**

- Premium aluminum oxide abrasive provides long life
- Strong, X-wt., 2-ply cotton backing construction for extended durability and reduced edge-wear
- Ideal for aggressive stock removal applications
- Resistant to heat

AVAILABILITY			TIER: GOOD	TIER: GOOD	TIER: GOOD			
			BRAND: Norton	BRAND: Norton	BRAND: Norton			
			ABRASIVE: Aluminum Oxide	ABRASIVE: Aluminum Oxide	ABRASIVE: Aluminum Oxide			
			BACKING: Cotton Standard	BACKING: Cotton Standard	BACKING: Cotton Standard – Vacuum			
			ATTACHMENT: TS (Type II)	ATTACHMENT: TR (Type III)	ATTACHMENT: TR (Type III)			
SIZE (D)	GRIT	STD. PKG.	PART NO.	PART NO.	PART NO.			
1	36	100	66261138098					
	50		66261138095					
	60		66261138090					
	80		66261138085					
	100		66261138080					
	120		66261138075					
1-1/2	36	100	66261138135	66261121009				
	40		66261138130					
	50		66261138125					
	60		66261138120	66261121012				
	80		66261138115	66261121013				
	100		66261138110	66261121014				
	120		66261138105	66261121015				
	180		66261138099					
	320		66261144113					
	2		24	100	66261138171	66261121018	 66254481586 66254481587 66254481588	
36		66261138170	66261121019					
40		66261138165	66261121020					
50		66261138160	66261121021					
60		66261138155	66261121022					
80		66261138150	66261121023					
100		66261138145	66261121024					
120		66261138140	66261121025					
150		66261138139	66261121026					
180		66261138138	66261121027					
240		66261138137	66261121028					
320		66261137346						
3		24	50		66261138206	66261121029		 66254481702 66254481703 66254481704
		36			66261138205	66261121030		
	40	66261138200		66261121031				
	50	66261138195		66261121032				
	60	66261138190		66261121033				
	80	66261138185		66261121034				
	100	66261138180		66261121035				
	120	66261138175		66261121036				
	150	66261137347		66261121037				
	180	66261138173		66261121038				
	240	66261138172		66261121039				



**Merit Silicon Carbide
Cloth Discs**

- Sharp, silicon carbide abrasive on X-wt. backing provides high initial cut and penetration for nonferrous materials

AVAILABILITY			TIER: GOOD	TIER: GOOD	TIER: GOOD
			BRAND: Merit	BRAND: Merit	BRAND: Merit
			ABRASIVE: Silicon Carbide	ABRASIVE: Silicon Carbide	ABRASIVE: Silicon Carbide
			BACKING: Cotton Standard	BACKING: Cotton Standard	BACKING: Cotton Standard
			ATTACHMENT: TS (Type II)	ATTACHMENT: TR (Type III)	ATTACHMENT: TP (Type I)
SIZE (D)	GRIT	STD. PKG.	PART NO.	PART NO.	PART NO.
2	40	100	08834165252	08834164275	08834162166
	60		08834165254	08834164163	08834162168
	80		08834165255	08834166155	08834162169
	120		08834165257	08834164837	08834162171
	180		08834165259	08834167313	08834162173
3	40	50	08834165267	08834164277	08834162185
	60		08834165269	08834164850	08834162187
	80		08834165270	08834166159	08834162188
	120		08834165272	08834166160	08834162190
	180		08834165274	08834168177	08834164971



Merit Aluminum Oxide Cloth Discs

- Aluminum oxide cloth discs are best used for general purpose deburring and blending on ferrous and nonferrous metals where greater edge durability is required
- Strong, Y-wt., 2-ply polyester backing construction for extended durability and reduced edge-wear

AVAILABILITY

TIER:	GOOD	GOOD	GOOD
BRAND:	Merit	Merit	Merit
ABRASIVE:	Aluminum Oxide	Aluminum Oxide	Aluminum Oxide
BACKING:	Polyester Standard	Polyester Standard	Polyester Standard
ATTACHMENT:	TS (Type II)	TR (Type III)	TP (Type I)

SIZE (D)	GRIT	STD. PKG.	PART NO.	PART NO.	PART NO.
3/4	24	100	08834165100	08834164312	08834161001
	36		08834165101	08834164319	08834161002
	40		08834165102	08834164321	08834161003
	50		08834165103	08834164322	08834161004
	60		08834165104	08834164813	08834161005
	80		08834165105	08834164323	08834161006
	100		08834165106	08834164814	08834161007
	120		08834165107	08834164324	08834161008
	150		08834165108	08834164815	08834161009
	180		08834165109	08834164325	08834161010
	240		08834165111	08834164326	08834161011
	320		08834165113	08834164327	08834161012
1	24	100	08834165115	08834164328	08834161014
	36		08834165116	08834166031	08834161015
	40		08834165117	08834161251	08834161016
	50		08834165118	08834164924	08834161017
	60		08834165119	08834161105	08834161018
	80		08834165120	08834166185	08834161019
	100		08834165121	08834161364	08834161020
	120		08834165122	08834161106	08834161021
	150		08834165123	08834164330	08834161022
	180		08834165124	08834166252	08834161023
	240		08834165126	08834166874	08834161025
	320		08834165128	08834164097	08834161026
1-1/2	24	100	08834165130	08834164969	08834161027
	36		08834165131	08834164048	08834161028
	40		08834165132	08834164804	08834161029
	50		08834165133	08834164092	08834161030
	60		08834165134	08834164902	08834161031
	80		08834165135	08834161400	08834161032
	100		08834165136	08834161288	08834161033
	120		08834165137	08834164905	08834161034
	150		08834165138	08834164810	08834161035
	180		08834165139	08834166251	08834161036
	240		08834165141	08834161602	08834161037
	320		08834165143	08834164331	08834161038
2	24	100	08834165145	08834164912	08834161041
	36		08834165146	08834164913	08834161042
	40		08834165147	08834166353	08834161043
	50		08834165148	08834164914	08834161044
	60		08834165149	08834161155	08834161045
	80		08834165150	08834164941	08834161046
	100		08834165151	08834164917	08834161047
	120		08834165152	08834161169	08834161048
	150		08834165153	08834164786	08834161049
	180		08834165154	08834164916	08834161050
	240		08834165156	08834164919	08834161051
	320		08834165158	08834166875	08834161052
3	24	50	08834165160	08834161214	08834161055
	36		08834165161	08834164938	08834161056
	40		08834165162	08834164939	08834161057
	50		08834165163	08834164940	08834161058
	60		08834165164	08834166183	08834161059
	80		08834165165	08834166191	08834161060
	100		08834165166	08834166189	08834161061
	120		08834165167	08834166184	08834161062
	150		08834165168	08834164340	08834161063
	180		08834165169	08834166187	08834161064
	240		08834165171	08834166225	08834161065
	320		08834165173	08834163205	08834161066
4	36	50	08834165176	08834166265	08834161070
	40		08834165177	08834164860	08834161071
	50		08834165178	08834164788	08834161072
	60		08834165179	08834164601	08834161073
	80		08834165180	08834166472	08834161074
	100		08834165181	08834164342	08834161075
	120		08834165182	08834166473	08834161076
	180		08834165184	08834164843	08834161078

Quick-Change Test Kit "D"



- Part No. 08834165001
- Includes 150 discs, assorted grits, in 1", 2", and 3" diameters and 3" back-up pads
- Primarily aluminum oxide cloth Quick-Change discs
- Several zirconia alumina and FlexEdge discs are included



Merit Aluminum Oxide fx and FlexEdge Cloth Discs

fx (conformable)

- These (flexible) aluminum oxide discs are designed for general purpose deburring and blending on contoured surfaces

FlexEdge

- Manufactured with special flexible aluminum oxide abrasive cloth where the outer 3/8" is more flexible than the rest of the disc
- Designed for softer metals where standard (fx) discs can gouge and for contour grinding of structural pieces
- Used in aircraft and aerospace manufacturing for structural hand polishing
- When using back-up pads for FlexEdge discs, order (use) one size smaller than the disc

AVAILABILITY		TIER:	GOOD	GOOD	GOOD
		BRAND:	Merit	Merit	Merit
		ABRASIVE:	Aluminum Oxide	Aluminum Oxide	Aluminum Oxide
		BACKING:	Cotton	Cotton	Cotton
			Flexible (fx)	FlexEdge	FlexEdge
		ATTACHMENT:	TS (Type II)	TS (Type II)	TP (Type I)
SIZE (D)	GRIT	STD. PKG.	PART NO.	PART NO.	PART NO.
1	24	100	08834168881		
	36		08834168479		
	40		08834168480		
	50		08834168481	08834163706	08834164309
	60		08834168431	08834160394	08834164296
	80		08834168432	08834160395	08834161194
	100		08834168482	08834160396	08834164215
	120		08834168434	08834160397	08834164216
	150		08834168483		
	180		08834168484		
	240		08834168485		
320	08834168486				
1-1/2	24	100	08834168882		
	36		08834168487		
	40		08834168488		
	50		08834168489	08834163713	08834166375
	60		08834168435	08834167333	08834164315
	80		08834168436	08834160399	08834164316
	100		08834168490	08834163714	08834164317
	120		08834168437	08834160401	08834164318
	150		08834168491		
	180		08834168492	08834160402	08834164320
	240		08834168493		
320	08834168494				
2	24	100	08834168883		
	36		08834168495		
	40		08834168496		
	50		08834168497	08834163721	08834164333
	60		08834168438	08834160403	08834164334
	80		08834168439	08834160404	08834164335
	100		08834168498	08834166959	08834164336
	120		08834168440	08834167363	08834164337
	150		08834168499		
	180		08834168500	08834160405	08834164339
	240		08834168501		
320	08834168502				
3	24	50	08834168884		
	36		08834168503		
	40		08834168504		
	50		08834168505	08834163728	08834164352
	60		08834168441	08834160406	08834164353
	80		08834168442	08834161282	08834164354
	100		08834168506	08834166974	08834164355
	120		08834168443	08834163729	08834164356
	150		08834168507		
	180		08834168508	08834160407	08834164358
	240		08834168509		
320	08834168510				
Back-up Pad for 3" FlexEdge Discs			Max. RPM 30,000	08834168539	08834163995

TECHtip

Avoid gouging on contours by using a smaller size back-up pad than the diameter of the discs, such as 1-1/2" back-up pad for 2" discs. For 3" discs and larger, order the special FlexEdge back-up pad that is 2" in diameter but contains the cam lock fastener for 3" and larger discs.



Quick-Change Back-up Pads

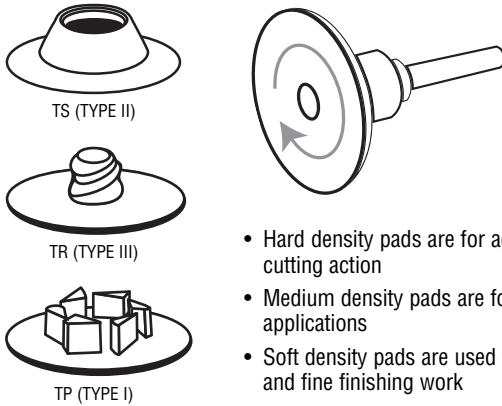

- Hard density pads are for aggressive cutting action
- Medium density pads are for all-purpose applications
- Soft density pads are used for contours and fine finishing work

DIAMETER	DENSITY	TS (TYPE II)	TR (TYPE III)	TP (TYPE I)
QUICK-CHANGE BACK-UP PADS				
9/16 40,000 RPM		66261054014		66261054013
3/4 40,000 RPM	Medium	08834164206	08834164038	08834164001
1 40,000 RPM	Medium	08834164651	08834164037	08834164002
1-1/2 30,000 RPM	Hard Medium	08834164622 08834164146	08834164640 08834161174	08834163996 08834164003
2 30,000 RPM	Hard Medium Soft	08834164624 08834164198 08834161625	08834164643 08834164922 08834164641	08834163997 08834164004 08834163949
3 20,000 RPM	Hard Medium Soft	08834161626 08834164113 08834164626	08834164036 08834164949 08834164644	08834163998 08834164005 08834163948
4 15,000 RPM	Medium	08834164135	08834164655	08834164006

ALL QUICK-CHANGE BACK-UP PADS HAVE A 1/4" SOLID STEEL SHANK. STD. PKG. = 1

Replacement Medium Density Rubber Pads for Quick-Change Back-up Pads

DIAMETER	MODEL NO.	TS (TYPE II)	TR (TYPE III)	TP (TYPE I)
QUICK-CHANGE REPLACEMENT RUBBER BACK-UP PADS				
3/4	RR75			08834164008
1	RR10			08834164009
1-1/2	RR15	08834168797	08834168885	08834164010
2	RR20	08834164973	08834163649	08834164011
3	RR30	08834164974	08834164970	08834164012
4	RR40			08834164013

WHEN THE RUBBER PAD HAS WORN AWAY, BUT THE STEEL COMPONENTS OF YOUR QUICK-CHANGE BACK-UP ARE STILL SERVICEABLE, ORDER THESE REPLACEMENT RUBBER PADS. STD. PKG. = 1

Replacement Assemblies and Shanks for Quick-Change Back-up Pad

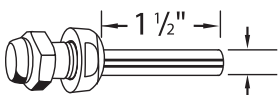

DESCRIPTION	STD. PKG.	PART NO.
REPLACEMENT MANDRELS AND NUT ASSEMBLY		
TP (Type I) Assembly RMN1 for 3/4 - 2	1	08834164015
TP (Type I) Assembly RMN3 for 3 - 4	1	08834164016
TS (Type II) & TR (Type III) Replacement 1/4" Shank	1	08834164303

ASSEMBLIES REPLACE ALL THE STEEL COMPONENTS OF A QUICK-CHANGE BACK-UP PAD. THIS SHANK REPLACES THE SCREW-IN 1/4" SOLID STEEL SHANK ONLY.

Extension Mandrels and Assembly

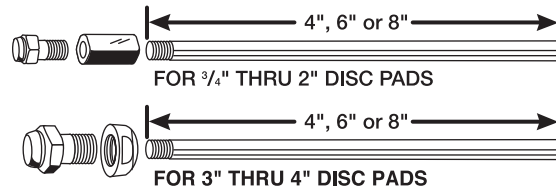

DIAMETER	MODEL NO.	LENGTH	STD. PKG.	PART NO.
EXTENSION MANDRELS AND ASSEMBLY – TP (TYPE I)				
3/4 - 2	EMN-14	4"	1	08834164017
3/4 - 2	EMN-16	6"	1	08834164018
3/4 - 2	EMN-18	8"	1	08834164019
3 - 4	EMN-34	4"	1	08834164020
3 - 4	EMN-36	6"	1	08834164026
3 - 4	EMN-38	8"	1	08834164021

MNA-1 Pad Adapters

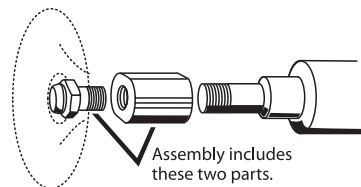

DISC DIAMETER	MODEL NO.	STD. PKG.	PART NO.
MNA-1 PAD ADAPTERS – TP (TYPE I)			
3/4 - 2	MNA 1/4-20 THD.	1	08834161176
3/4 - 2	MNA 3/8-24	1	08834164055
3/4 - 2	MNA 5/8-11	1	08834163001
3 - 4	MNA 1/4-20	1	08834163002
3 - 4	MNA 3/8-24	1	08834164041
3 - 4	MNA 5/8-11	1	08834164028

CONVERT A TP (TYPE I) BACK-UP PAD 1/4" DIAMETER SOLID SHANK TO A THREADED SHANK

MNA-23 Pad Adapters

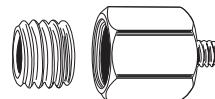

DISC DIAMETER	MODEL NO.	STD. PKG.	PART NO.
MNA-23 PAD ADAPTERS – TS (TYPE II) AND TR (TYPE III)			
3/4 - 4	MNA-23 3/8-24 THD. & 5/8-11	1	08834162764

FOR USE ON A RIGHT ANGLE GRINDER: CONVERT TS (TYPE II) AND TR (TYPE III) BACK-UP PAD 1/4" DIAMETER SOLID SHANKS TO THREADED SHANKS. THE LARGER 5/8-11 ADAPTER (FOR 4-1/2" DISCS) IS USED ALONE TO CONVERT TO A 5/8-11 THREAD. THE 3/8-24 INSERT (FOR 4" DISCS) IS SCREWED INTO THE 5/8-11 ADAPTER TO CREATE A 3/8-24 THREAD ADAPTER.

1/4" Diameter Extension Mandrel

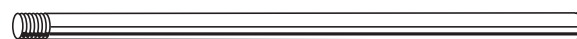

USE WITH TP (TYPE I), TS (TYPE II), TR (TYPE III)

MODEL NO.	LENGTH	STD. PKG.	PART NO.
1/4" DIAMETER EXTENSION MANDREL 1/4-20 THREAD			
EM-144	4	1	08834154185
EM-146	6	1	08834154186
EM-148	8	1	08834154187



CATEGORY DEFINITION

Paper sheets and rolls are engineered for optimum performance when sanding metal, wood, composites and painted surfaces. The sheets are packed in protective packaging to eliminate waste and permit easy, neat storage.

- CATEGORIES:** Stearated (non-loading) Ceramic Alumina, Aluminum Oxide and Silicon Carbide
Waterproof Aluminum Oxide and Silicon Carbide
All Purpose Aluminum Oxide and Garnet
Heavyweight Zirconia Alumina
- APPLICATIONS:** Light-duty metal sanding, primer sanding, defect removal from painted surfaces, filler sanding, sanding and finishing of composites and fiberglass, bare wood sanding, sanding between sealer coats
- SIZE RANGE:** Full Sheets, Cut Sheets, File Strips and Rolls
- GRIT RANGE:** 36 – 2500
- ABRASIVE GRAIN:** Ceramic Alumina, Zirconia Alumina, Aluminum Oxide, Silicon Carbide

MATERIAL-TO-PRODUCT RECOMMENDATION GUIDE

	BEST HIGHEST PRODUCTIVITY LOWEST TOTAL COST	BETTER EXCELLENT BLEND OF PERFORMANCE & PRICE	GOOD CONSISTENT PERFORMANCE LOW INITIAL PRICE
Unfinished Metal	A275	–	A251
Primed / Painted Surfaces / Between Coats	A275	A475	A251
Fiberglass / Composites	A275	A475	A251
Bare Wood	A275	–	A511, A513, A514
Clear Coat Sanding	T214, T401	–	T461
Sealer Sanding	A275	A475	A251
Lacquer Sanding	T214, T401	T414	T461
Wet Sanding	T214, T401	T414	T461
Paint Stripping	A259 (3X)	A475	A290
All Purpose Dry Sanding	A259 (3X)	–	A212, A213, A211

APPLICATION/GRIT RECOMMENDATION GUIDE

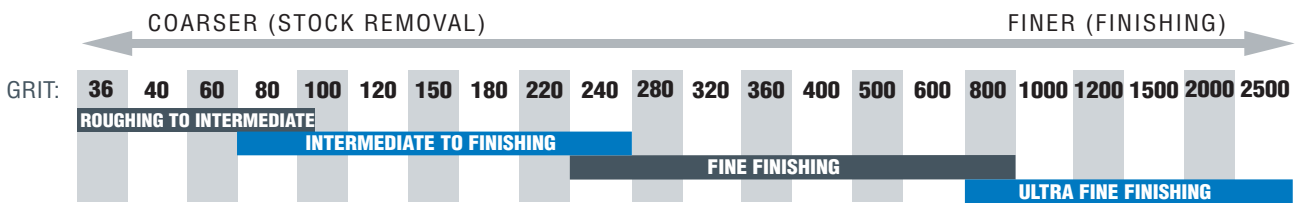

RECOMMENDED BACKING WEIGHT

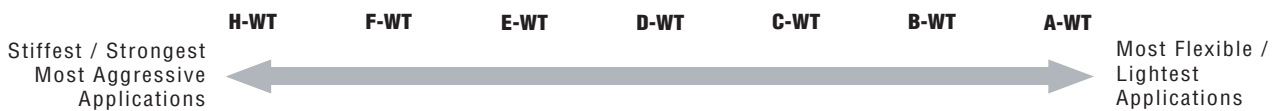



CROSS REFERENCE GUIDE

NORTON	3M	Hermes	Klingspor	Mirka	SIA	VSM
STEARATED						
A975	734U, 735U, 765L, 334U	-	-	-	1950 siaspeed	-
A275 / A259 (3X)	216U, 334U	HC133	PS33	Royal, Royal Micro	1950 siaspeed	-
A475	405N, 414N, 415N/U	PSF-LL, SA168	PL35	Carat Flex, FineFlex	1701 sialac 1748 siarexx fine	CP131A
A290	236U	HCAB-LL	PS33, PL36	Bulldog Gold	1960 siarexx cut	KP911
A251	316U, 214U	-	PL36	GoldFlex	-	-
WATERPROOF						
T214	213Q	WAFlex28B	PS12	-	1913 siawat	-
T401	401Q	WSFlex16	PS11, PS14	Waterproof (A)	-	CP918A
T414	413Q	WSFlex16	PS11, PS14	Waterproof (A)	-	CP918A
T461	438Q, 431Q	WSFlex18C	PS11, PS14	-	1727 siawat	CP918C
ALL PURPOSE/WOOD						
A211	230U, 240N, 346U	-	-	-	-	KP31C
A212	210N	HFB	PL31	-	-	-
A213	230N	HFB	PL31	-	-	KP31B
A511	110N	-	-	-	1400 sianor	-
A513	130N	GCAB	-	-	-	-
A514	140N	GCAB	-	-	-	-
HEAVYWEIGHT PAPER						
H875	750U, 751U, 740I, 745I	-	-	Royal Coarse Cut	-	KP510E, KP709

Aluminum Oxide All-Purpose Sanding and Garnet Wood Sanding 9 x 11 Paper Sheets

AVAILABILITY
9 X 11
PAPER SHEETS

		GOOD	GOOD	GOOD	GOOD	GOOD	GOOD	GOOD
		Norton	Norton	Norton	Norton	Norton	Norton	Norton
		A211	A213	A212	A211/A213/A212 MULTISAND	A514/A513	A511	A514/A513/A511 WOODSAND
		Aluminum Oxide	Aluminum Oxide	Aluminum Oxide	Aluminum Oxide	Garnet	Garnet	Garnet
		D-Weight	C-Weight	A-Weight	D-, C- & A-Weight	D- & C-Weight	A-Weight	D-, C- & A-Weight
		P-Graded	P-Graded	P-Graded	P-Graded			
SIZE	GRIT	MIN./STD. PKG.	PART NO.	PART NO.	PART NO.	PART NO.	PART NO.	PART NO.
9 x 11	36	25/125	66261100335			07660700361*		
	40		66261100330					
	50	50/250	66261100325			07660700360*	66261101565	
	60		66261100320			07660701624*	66261101560	
	80		66261100315			07660700359*	66261101555	66261101505
								07660701584
	100	100/500		66261100295		07660700358*	66261101535	66261101500
	120			66261100290		07660700357*	66261101530	66261101495
	150			66261100285		07660700356*	66261101525	66261101490
	180				66261100245	07660700355*		66261101489
	220				66261100240	07660700354*		66261101488
	240							66261101487
	280						66261101486	
	Asst*					07660700365*		

* PACKAGING STANDARDS: JOB PACKS: 25 SHEETS PER PACK / 10 PACKS PER STANDARD PACKAGE FOR A TOTAL OF 250 SHEETS
 • ASSORTED CONTAINS 6 EACH OF 60, 100, 150 GRIT AND 7 EACH OF 220 GRIT



Stearated (Non-Loading) Aluminum Oxide and Silicon Carbide 9 x 11 Paper Sheets

FEATURED PRODUCTS



NO-FIL ADALOX A275

THE BEST CHOICE FOR SANDING PAINTED SURFACES, COMPOSITES, PLASTICS, OR ANY MATERIAL THAT TENDS TO LOAD

FEATURES

- Premium P-graded, heat-treated aluminum oxide abrasive
- Unique fiber-reinforced, B-wt. latex-saturated backing
- Water-based stearate, non-pigmented, No-Fil coating
- Full resin adhesive bond

BENEFITS

- Superior life, fast cut rate, consistent finish
- 50-60% improvement in tear strength
- Exceptional flexibility, can be folded without cracking
- Provides maximum load resistance and extended life; no color transfer to work
- Provides exceptional resistance to abrasive grain shedding especially when folding to sand into corners; long life

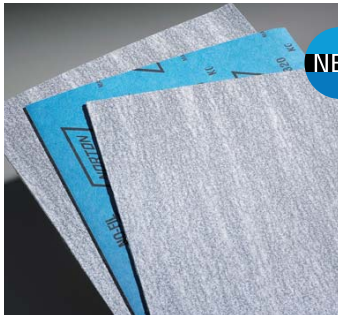

NO-FIL DURITE A475

THE BETTER CHOICE FOR GEL COATS, HARD COMPOSITE SUBSTRATES, ABRASION-RESISTANT COATINGS, AND WOODWORKING APPLICATIONS

FEATURES

- P-graded, silicon carbide abrasive
- Water-based stearate, non-pigmented, No-Fil coating
- Fiber-reinforced, latex paper backing

BENEFITS

- Easy penetration of the hardest surfaces
- Resists loading for longest usable product life, no color transfer to work
- Provides flexibility and resistance to tearing

AVAILABILITY
9 X 11
PAPER SHEETS

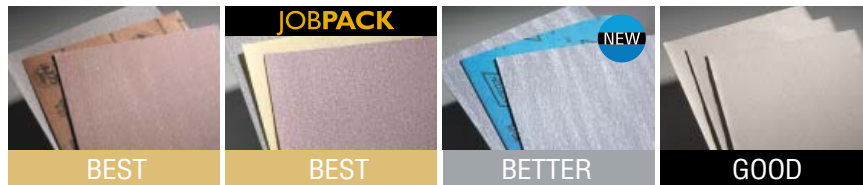

TIER:	BEST	BEST	BETTER	GOOD
BRAND:	Norton	Norton	Norton	Norton
TRADENAME:	A275 NO-FIL	A259 (3X) NO-FIL	A475 NO-FIL	A251 NO-FIL
ABRASIVE:	Aluminum Oxide	Aluminum Oxide	Silicon Carbide	Aluminum Oxide
BACKING WEIGHT:	B-Weight	B-Weight	B-Weight	A-Weight
OTHER:	P-Graded	P-Graded	P-Graded	P-Graded

SIZE	GRIT	MIN./STD. PKG.	PART NO.	PART NO.	PART NO.	PART NO.			
9 x 11	60	50/250	66261131634	07660702642*	66254487393	66261184107			
			66261131634	07660702641*		66261184106			
	100	500	66261131633	07660702640*		66254487394	66261184106		
			66261131632	07660702639*		66254487395	66261184105		
			66261131631	07660702638*		66254487396	66261184108		
			66261131630	07660702637*		66254487397	66261184104		
			66261131629	07660702636*		66254487398	66261184103		
			66261131628			66254487399	66261184102		
			66261131627						
			66261131626	07660702633*		66254487400	66261184100		
			66261131624	07660702632*			66261184098		
			66261131623						
			66261131622						
			66261131621						
			1000	100/500		66261131620			
			1200			66261131619			
			1500			66261131618			

* PACKAGING STANDARDS: A259 (3X) JOB PACKS: 20 SHEETS PER PACK / 10 PACKS PER STANDARD PACKAGE FOR A TOTAL OF 200 SHEETS



Waterproof Aluminum Oxide and Silicon Carbide 9 x 11 Paper Sheets

FEATURED PRODUCTS

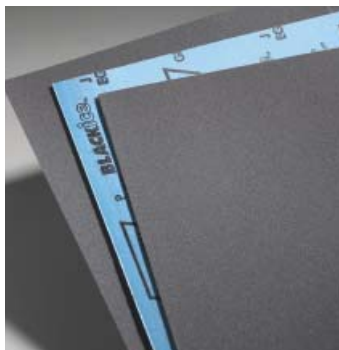

BLACK ICE T214 AND T401 WATERPROOF BEST CHOICE FOR ALL WET APPLICATIONS

FEATURES	BENEFITS
• T214: Premium, P-graded, heat-treated aluminum oxide abrasive	• Ultimate cut and life in wet applications
• T401: Premium, ultra fine (1000 – 2500 JIS graded) silicon carbide abrasive	• Ultimate finish in wet applications
• Improved resin bond system	• Long life in wet applications
• High-strength B-wt, high-latex, waterproof paper backing	• Ultimate flexibility, with wet-curl resistance • Environmentally stable, resists humidity-caused curling

AVAILABILITY
9 X 11
PAPER SHEETS

TIER:	BEST	BEST	BETTER	GOOD
BRAND:	Norton	Norton	Norton	Norton
TRADENAME:	T214	T401	T414	T461
ABRASIVE:	Aluminum Oxide	Silicon Carbide	Silicon Carbide	Silicon Carbide
BACKING WEIGHT:	B-Weight	B-Weight	B-Weight	C-Weight
OTHER:	P-Graded	JIS Graded	CAMI Graded	CAMI Graded

SIZE	GRIT	MIN./STD. PKG.	PART NO.	PART NO.	PART NO.	PART NO.	
9 x 11	60	50/250				66261101175	
	80					66261101170	
	100					66261101165	
	120					66261101160	
	150					66261101155	
	180					66261101150	
	220			66261139389		66261139367	
	240			66261139388		66261139366	66261130331
	280			66261139387		66261139365	
	320			66261139386		66261139364	66261130332
	360			66261139346		66261139363	
	400			66261139385		66261139362	66261130333
	500			66261139384		66261139361	
	600			66261139383		66261139360	66261130334
	800			66261139382			
	1000		50/250		66261139381		
	1200				66261139380		
1500			66261139379				
2000			66261139378				
2500			66261139377				

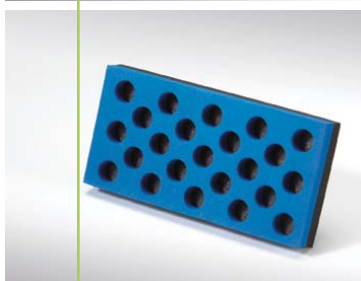

Waterproof Sanding Blocks – with “grabbing” power

Dual Density Wet Sanding Block

- No adhesive required: simply wrap a 5-1/2" x 9" (9" x 11" cut in half) sheet around the block
- The dense side is for more aggressive blocking, while the soft side is for color sanding
- Equalizes sanding pressure for fine grit applications

Holey Block

- No adhesive required: simply wrap a 5-1/2" x 9" (9" x 11" cut in half) sheet around the block
- A rugged, semi-rigid, multi-purpose sanding block engineered for flat to medium curved surfaces
- A tactical hole pattern side provides numerous cutting edges to create a 30% faster cut rate
- The plain side provides firmness and a comfortable, easy-to-hold surface

DESCRIPTION	STD. PKG.	PART NO.
Wet Sanding Block	12	63642503728
Holey Block	8	63642503729



File Strips / Hand Sanding Cut Sheets / Rolls

FEATURED PRODUCTS

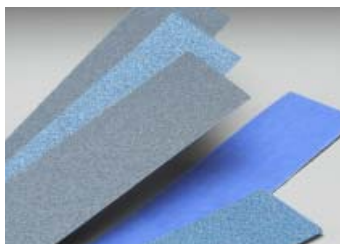

NORZON H875

EXCELLENCE FOR SOFT MATERIAL APPLICATIONS

FEATURES

- Patented NorZon zirconia abrasive
- Strong E-weight paper, latex impregnated
- Open coat design

BENEFITS

- Extended life over original NorZon products
- Increased durability and chip resistance, flexible
- Reduced loading; ideal for body filler, fiberglass and composite sanding

AVAILABILITY
PAPER
FILE STRIPS

TIER:
BRAND:
TRADENAME:
ABRASIVE:
BACKING WEIGHT:
BACKING ATTACHMENT:
OTHER:

BEST	BEST	BEST	BEST	GOOD	BETTER	BETTER	BETTER
Norton	Norton	Norton	Norton	Norton	Norton	Norton	Norton
A275 NO-FIL	A275 NO-FIL	A275 NO-FIL	A275 NO-FIL	H290	H875	H875	H875
A/O	A/O	A/O	A/O	A/O	Z/A	Z/A	Z/A
B-Wt.	B-Wt.	B-Wt.	B-Wt.	E-Wt.	E-Wt.	E-Wt.	E-Wt.
Non-PSA	PSA	Hook/Loop	Hook/Loop Vac	PSA	Non-PSA	PSA	Hook/Loop
P-Graded	P-Graded	P-Graded	P-Graded	P-Graded			

SIZE	GRIT	MIN./STD. PKG.	PART NO.	PART NO.	PART NO.	PART NO.	PART NO.	MIN./STD. PKG.	PART NO.	PART NO.	MIN./STD. PKG.	PART NO.
2-3/4 x 16	100 120 180	50/500				66261131657 66261131656 66261131654						
2-3/4 x 16-1/2	36 40 80 100 120 150 180 220	50/500		66261131640 66261131639 66261131637 66261131636	66261131646 66261131645 66261131644 66261131643 66261131642 66261131641		66261130840	50/250		66261123610 66261123609 66261123608	25/125	66261123616 66261123615 66261123614
2-3/4 x 17-1/2	36 40 80 100 120 150 180 220	50/500	66261131652 66261131651 66261131650 66261131649 66261131648 66261131647					50/250	66261123622 66261123621 66261123620 66261126512 66261126511			



VACUUM HOLE PATTERN FOR 2-3/4 X 16 FILE STRIPS

Sanding Boards



PSA/Non-PSA Sanding Board

- This sanding board has a cushioned surface
- Spring clips mounted at each end securely hold 2-3/4" x 16-1/2" PSA file strips and 2-3/4" x 17-1/2" non-PSA file strips



Hook and Loop and Non-PSA Sanding Board

- Lightweight, rugged design for easy sanding of plastic fillers
- Spring clips mounted at each end securely hold 2-3/4" x 16-1/2" hook and loop file strips and 2-3/4" x 17-1/2" non-PSA file strips

DESCRIPTION	STD. PKG.	PART NO.
Hook & Loop File Strip Sanding Board	5	63642552836
PSA File Strip Sanding Board	6	63642542724



AVAILABILITY
PAPER CUT SHEETS



TIER:	BETTER	GOOD	GOOD	GOOD
BRAND:	Norton	Norton	Norton	Norton
TRADENAME:	T414	A290 NO-FIL	A211	A213
ABRASIVE:	Silicon Carbide	Aluminum Oxide	Aluminum Oxide	Aluminum Oxide
BACKING WEIGHT:	B-Wt.	C-Wt.	D-Wt.	C-Wt.
OTHER:	Waterproof	P-graded	P-graded	P-graded



Rubber Hand Sanding Blocks

- Resilient rubber blocks that conform well to mild contours and flat surfaces

DESCRIPTION	STD. PKG.	PART NO.
2-3/4 x 5	5	07660701889
3-2/3 x 9	14	07660743140

SIZE	GRIT	MIN./STD. PKG.	PART NO.	PART NO.	PART NO.	PART NO.	
3-2/3 x 9	60	100/1000	66261139359	66261101119	66261102925	66261102920	
	80						
	100						
	120						
	150						
	180						
	220						
	280						
	320						
	400						
	600						
							66261102900
							66261102895

AVAILABILITY
PSA PAPER ROLLS



TIER:	BEST	BEST	BEST	BEST	BEST	BEST	BEST	GOOD	GOOD
BRAND:	Norton	Norton	Norton	Norton	Norton	Norton	Norton	Norton	Norton
TRADENAME:	A975 NO-FIL	A975 NO-FIL	A975 NO-FIL	A275 NO-FIL	A275 NO-FIL	A275 NO-FIL	A275 NO-FIL	A290 NO-FIL	A290 NO-FIL
ABRASIVE:	C/A	C/A	C/A	A/O	A/O	A/O	A/O	A/O	A/O
BACKING WEIGHT:	C-Wt.	C-Wt.	B-Wt.	B-Wt.	B-Wt.	B-Wt.	B-Wt.	C-Wt.	C-Wt.
OTHER:	P-Graded	P-Graded	P-Graded	P-Graded	P-Graded	P-Graded	P-Graded	P-Graded	P-Graded
SIZE:	2-3/4" x 25yd	2-3/4" x 30yd	2-3/4" x 45yd	2-3/4" x 25yd	2-3/4" x 30yd	2-3/4" x 45yd	4-1/2 x 10 yd	2-3/4" x 20yd	2-3/4" x 25yd

GRIT	MIN./STD. PKG.	PART NO.	PART NO.	PART NO.	PART NO.	PART NO.	PART NO.	PART NO.	PART NO.	
80	1/5	66261149566	66261149565	66261149562	66261131691	66261131690	66261131688	66261131697	66261160325	
100										
120										
150										
180										
220										
240										
320										
400										
600										
										66261149564
										66261149561
										66261131689
										66261131686
	66261131685									
	66261131683									
	66261131681									
	66261131679									



PSA Roll Accessories

PSA Roll Dispenser

- Heavy-duty wire dispenser has a vinyl coating to protect the work surface
- Accommodates two 2-3/4" PSA rolls; stackable for multi-grit operations. Attach to wall or mount on cabinet



PSA Sanding Blocks

- Ergonomically-shaped flexible foam blocks used with 2-3/4" rolls, fit comfortably in your hand
- Firm block produces a true flat surface
- The soft block is designed for flat surfaces and contours

DESCRIPTION	STD. PKG.	PART NO.
PSA Roll Dispenser	1	63642542773

SIZE	DESCRIPTION	STD. PKG.	PART NO.
2-3/4 x 5	PSA – Soft	5	63642542090
2-3/4 x 5	PSA – Firm	5	63642542091
2-3/4 x 7-3/4	PSA – Firm	5	63642542094



Rotolo Foam Sanding Pads

FEATURED PRODUCTS



NORTON A275

THE BETTER CHOICE FOR FINE SANDING FLAT AND CURVED SURFACES

FEATURES

- A275 (premium P-graded, aluminum oxide grain with No-Fil coating) on Rotolo foam backing
- 4-1/2" wide x 82" long roll perforated every 5-1/2"
- Convenient dispensing box

BENEFITS

- Perfect for hand sanding without leaving finger marks
- Provides outstanding finish on wood, metal, and composites, and primers, sealers and top coats
- Fast cut and long life without loading
- Compatible with all coatings
- 50% – 60% improvement in tear strength
- Standard 1/4 sheet size for hand or machine sanding; 178 sheets per roll
- Protects A275 Rotolo foam from damage

APPLICATION/GRIT RECOMMENDATION GUIDE

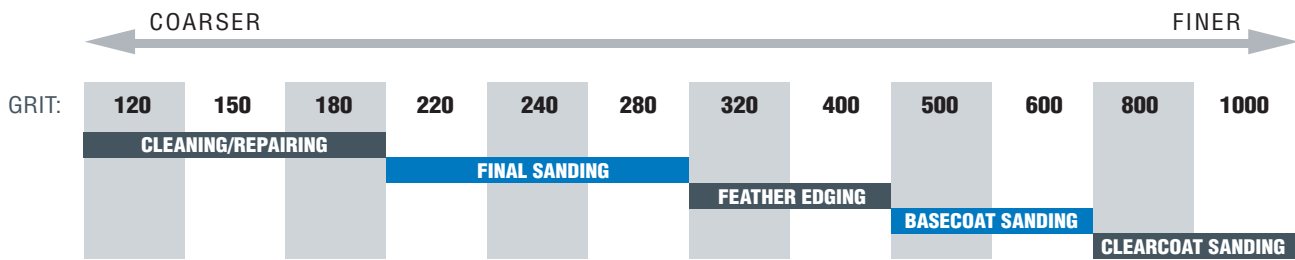

AVAILABILITY

TIER:	BETTER
BRAND:	Norton
TRADENAME:	ROTOLO
ABRASIVE:	Aluminum Oxide

SIZE (W X L)	GRIT SIZE	STD. PKG.	PART NO.
4-1/2" x 82'	P120	2	6364255316
	P150	2	63642557584
	P180	2	63642557599
	P220	2	63642557600
	P240	2	63642557602
	P280	2	63642557604
	P320	2	63642557606
	P400	2	63642557608
	P500	2	63642557611
	P600	2	63642557612
	P800	2	63642557613
P1000	2	63642557616	





CATEGORY DEFINITION

Engineered for flexibility and fast cutting, cloth sheets and rolls have a longer life than paper. They tear cleanly and straight without shedding and are packed in a protective dispenser to eliminate waste and damage.

- CATEGORIES: All Purpose Aluminum Oxide Cloth Sheets and Rolls (Metalite), Emery Cloth Sheets, Silicon Carbide Screen Sheets and Rolls
- APPLICATIONS: Scouring and light deburring, scale and rust removal, blending and fine sanding, polishing lathe turnings, rolls and cylinders, and blending machine tool marks
- SIZE RANGE: Sheets: 9" x 11"
Rolls: 1" x 10 yds., 1-1/2" – 2" x 25 yds., 1" – 4" x 50 yds.
- GRIT RANGE: 40 – 600, extra coarse, coarse, medium, fine
- ABRASIVE GRAIN: Aluminum Oxide, Silicon Carbide, Emery

CROSS REFERENCE GUIDE

	GOOD			
	Metalite K224/K225	Metalite K227	Emery K622	Screen-Bak Q421
3M	311T Three-M-lte BG 211K Electrocut	211K Three-M-lte 311K Three-M-lte	011k Crystal Bay	481Q
Hermes	RB317LX	RB232J	–	–
Klingspor	CS310X	KL361	KL371	–
Sait	DA-F	EA-F	–	Saitscreen
SIA	–	2947J	C680J	–
VSM	KK504X	KK504J, KK504X	–	–

APPLICATION/STARTING RECOMMENDATION GUIDE

Durability/Stock Removal Fast Cut	Conformability Excellent Finish	Slower Cut Fine Finish	Waterproof Load Resistant
Metalite K224/K225	Metalite K227	Emery K622	Screen-Bak Durite Q421

AVAILABILITY
CLOTH SHEETS

TIER:	GOOD	GOOD	GOOD	GOOD
BRAND:	Norton	Norton	Norton	Norton
TRADENAME:	METALITE K224/K225	METALITE K227	EMERY K622	SCREEN-BAK Q421
ABRASIVE:	Aluminum Oxide	Aluminum Oxide		Silicon Carbide
OTHER:	P-Graded	P-Graded		P-Graded/Waterproof

SIZE (D X H)	GRIT	MIN./STD. PKG.	PART NO.	PART NO.	PART NO.	MIN. STD. PKG.	PART NO.
9 x 11	40	25/125	66261058713				
	50	25/125	66261101862				
	60	25/125	66261101861				
	80	25/125	66261126340	66261101750		25/125	66261100960
	100	50/250	66261126339	66261101745		25/125	66261100955
	120	50/250	66261126338	66261101740		25/125	66261100950
	150	50/250	66261126337	66261101735		25/125	66261100945
	180	50/250	66261126336	66261101730		25/125	66261100940
	220	50/250	66261126335			25/125	66261100935
	240	50/250	66261126334				
	280	50/250	66261126333	66261101720			
	320	50/250	66261126332	66261101710		25/125	66261100920
	400	50/250	66261126331	66261101705		25/125	66261100915
	500	50/250		66261101700			
	600	50/250	66261126330				
	Extra Coarse	25/125			66261101255		
	Coarse	25/125			07660701307		
	Medium	50/250			07660701309		
	Fine	50/250			07660701308		



AVAILABILITY
CLOTH ROLLS



TIER:	GOOD	GOOD	GOOD	GOOD	GOOD
BRAND:	Norton	Norton	Norton	Norton	Norton
TRADENAME:	K224/K225	K224/K225	K224/K225	K224/K225	K224/K225
ABRASIVE:	Aluminum Oxide	Aluminum Oxide	Aluminum Oxide	Aluminum Oxide	Aluminum Oxide
SIZE:	1" x 10 yds	1" x 50 yds	1-1/2" x 50 yds	2" x 50 yds	4" x 50 yds
OTHER:	P-Graded	P-Graded	P-Graded	P-Graded	P-Graded

GRIT	MIN./STD. PKG.	PART NO.	PART NO.	PART NO.	PART NO.	PART NO.
40	1/5		66261058716	66261058715	66261058714	
50			66261127728	66261127730	66261127732	
60			66261127729	66261127731	66261127733	
80		66261134298	66261126276	66261126288	66261126299	
100		66261134299	66261126275	66261126287	66261126298	
120		66261134300	66261126274	66261126286	66261126297	66261127285
150		66261134301	66261126273	66261126285	66261126296	
180		66261134302	66261126272	66261126284	66261126295	
220			66261126271	66261126283	66261126294	
240		66261134303	66261126270	66261126282	66261126293	
280			66261126269	66261126281	66261126292	
320		66261134304	66261126268	66261126280	66261126291	
400			66261126267	66261126279	66261126290	
600			66261126266	66261126278	66261126289	

AVAILABILITY
CLOTH ROLLS



TIER:	GOOD	GOOD	GOOD	GOOD	GOOD
BRAND:	Norton	Norton	Norton	Norton	Norton
TRADENAME:	K227	K227	K227	Q421	Q421
ABRASIVE:	Aluminum Oxide	Aluminum Oxide	Aluminum Oxide	Silicon Carbide	Silicon Carbide
SIZE:	1" x 50 yds	1-1/2" x 50 yds	2" x 50 yds	1-1/2" x 25 yds	2" x 25 yds
OTHER:	P-Graded	P-Graded	P-Graded	P-Graded Waterproof	P-Graded Waterproof

GRIT	MIN./STD. PKG.	PART NO.	PART NO.	PART NO.	PART NO.	PART NO.
80	1/5	66261109180	66261109255	66261109335	66261107275*	
100		66261058721	66261058719	66261109330		
120		66261109170	66261109245	66261109325	66261107270*	66261149811*
150		66261058720	66261058717	66261109320		
180		66261109160	66261109235	66261109315	66261107265*	
240			66261109225	66261109305		
280		66261109150				
320		66261109140	66261109215	66261109295		

* PACKAGING STANDARDS: MIN. /STD. PKG.: (Q421) 1/10

FastTrack Service – Cloth Rolls

FastTrack delivery is available on made-to-order aluminum oxide R228 and K225 50-yard rolls with 5-day lead-time. Contact your local distributor for details and prices.

Availability

- Width: 2" – 12"
- Length: 50 yards

FastTrack Roll Quantity Availability

WIDTH	MINIMUM QTY.	MAXIMUM QTY.
2" to <3"	5 Rolls	10
3" to <4"	4 Rolls	8
4" to <5"	3 Rolls	6
5" through 7"	2 Rolls	4
>7" through 12"	1 Roll	2





CATEGORY DEFINITION

Flexible, abrasive sanding sponges for a wide variety of curved, contoured or flat surface applications on wood, metal, paint, plastic, ceramics and drywall.

APPLICATIONS: Light stock removal, sanding sealer and wash-coats, touch-up or repair of primer, sanding contours and intricate shapes, and finishing

- BENEFITS:**
- Can be used wet or dry
 - Clog resistant, washable, reusable
 - Easy to use, can be folded without cracking
 - Conformable
 - Generate a consistent surface finish

WHY CHOOSE ABRASIVE SPONGES VERSUS CONVENTIONAL SHEETS?

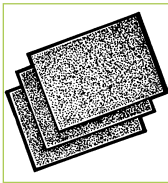

Eliminate Clogging

- The combination of flexible foam backing material and abrasive grit continually releases sanded material
- Any clogging can be washed out

Pressure Control

- Foam backing allows optimum pressure distribution to prevent sanding through surfaces
- Pressure spots are eliminated providing even surface pattern

Adapt to Contours

- Flexible foam allows adaptability to contours, shapes or areas of limited access
- No folding or buckling results in an even pattern without scratching

SURFACE FINISHING CHART – CONTOUR SPONGES VERSUS SHEETS

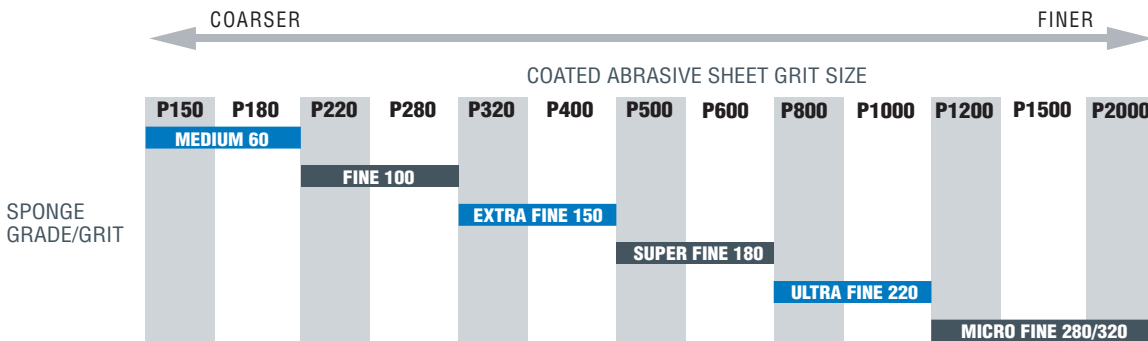

SURFACE FINISHING CHART – SPONGE PADS VERSUS SHEETS

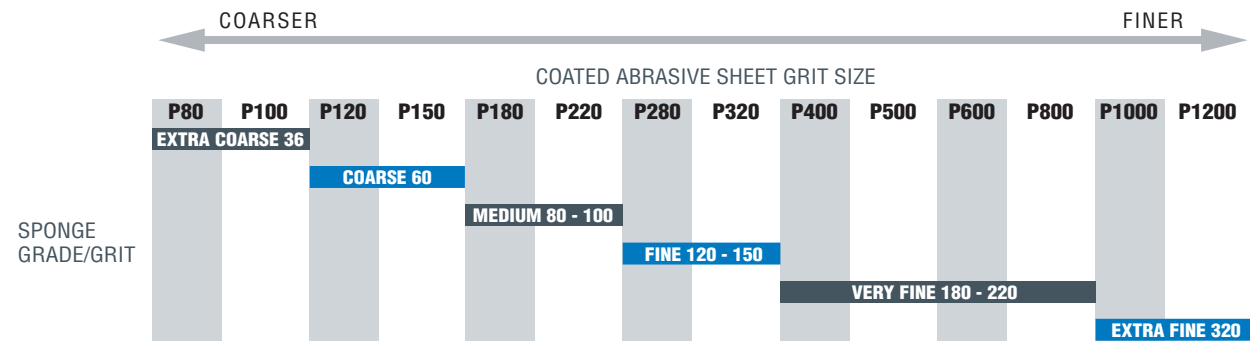

CROSS REFERENCE GUIDE

	BETTER SoftTouch	GOOD CONTOUR	GOOD SMALL AREA	GOOD PROFILE	GOOD SEALER SANDING	GOOD FLEXIBLE
NORTON						
3M	Softback	Contour	Full Size	High Flexibility	Woodworking	Pro Pads
Hermes	Single Side	-	Four Sided	-	Two Sided	-
Klingspor	-	-	-	-	Foam Sanding Pad	-
SIA	Flat Pad	-	Standard Block	-	Standard Pad	-



FEATURED PRODUCTS AND AVAILABILITY

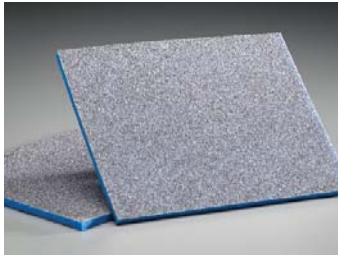

BETTER SOFTTOUCH CONTOUR SPONGES – COATED 1 SIDE

- Superior flexibility; for hand-sanding or finishing flat, curved, contoured and hard-to-reach areas on wood, metal, composites, paint and solid surfaces
- Premium foam substrate provides for an extremely smooth and uniform sanded surface

SIZE (W X L X T)	GRIT	STD. PKG.	PART NO.
4-1/2 x 5-1/2 x 3/16	60 Medium	80	07660703074
	100 Fine	80	07660703075
	180 Super Fine	80	07660703076
	220 Ultra Fine	80	07660703077
	280 Micro Fine	80	07660703078



GOOD CONTOUR SPONGES – COATED 1 SIDE

- Thin, flexible; good for sanding small diameters and contours such as ceramics, spindles, turnings and railings

SIZE (W X L X T)	GRIT	STD. PKG.	PART NO.
4-1/2 x 5-1/2 x 3/16	100 Fine	100	07660702257
	150 Extra Fine	100	07660702256
	220 Ultra Fine	100	07660702255
4-1/2 x 5-1/2 x 3/16	100 Fine	100	69957391449
	150 Extra Fine	100	66261091122
	220 Ultra Fine	100	66261041891



GOOD SMALL AREA GENERAL PURPOSE SPONGES – COATED 4 SIDES

- Good for a wide variety of materials and sanding applications where moderate flexibility is needed
- Medium to firm density open cell polyurethane foam provides uniform support and moderately aggressive cutting action while generating a smooth surface

SIZE (W X L X T)	GRIT	STD. PKG.	PART NO.	STD. PKG.	PART NO.
4 x 2-3/4 x 1	36/80 Ex. Coarse/Med	24	07660749505	250	07660704735
	80/80 Med/Med	24	07660749507	250	07660701875
	80/120 Med/Fine	24	07660749504	250	07660702600
	120/120 Fine/Fine	24	07660749506	–	–



GOOD PROFILE SPONGES – COATED 3 SIDES

- Good for corners and flat surfaces on wood, metal, plastic and paint
- Ideal for cabinet sanding of raised profile doors

SIZE (W X L X T)	GRIT	STD. PKG.	PART NO.
4 x 2-3/4 x 1/2	60 Coarse	500	63642536314
	100 Medium	500	63642536313

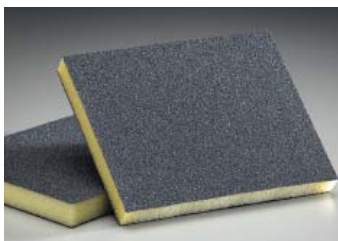

GOOD SEALER SANDING SPONGES – COATED 2 SIDES

- Very flexible; silicon carbide abrasive for sanding primers, sealers and between coats on furniture and cabinets

SIZE (W X L X T)	GRIT	STD. PKG.	PART NO.
4-3/4 x 3-3/4 x 1/2	60 Coarse	250	63642536334
	80 Medium	250	63642502538
	100 Medium	250	63642552870
	150 Fine	250	63642552869
	220 Very Fine	250	63642552868



GOOD FLEXIBLE ABRASIVE SPONGES – COATED 1 SIDE

- Ideal for final sanding of surfaces, primer sanding and between coats sanding
- Best initial price point for abrasive sponges

SIZE (W X L X T)	GRIT	STD. PKG.	PART NO.	STD. PKG.	PART NO.
3 x 4 x 1/2	60 Coarse	48	07660704068	108	07660701110
	80 Medium	48	07660704067	108	07660704070
	100 Medium	48	07660704066	108	07660700950
	150 Fine	48	07660704065	108	07660700949
	220 Very Fine	–	–	108	07660704069



CATEGORY DEFINITION

Norton flexible diamond products combine the durability and aggressiveness of diamond, on a flexible backing.

- APPLICATIONS:** Flexible Diamond Hand Pads: Shaping, rapid stock removal, touch-up and repair on ceramics, stone, marble, glass, composites and hard materials. Polishing of dies and molds.
- Quadraflex Diamond Hand Pads: Surface conditioning, repairs, and removing flash and burrs on aircraft composites. Surface conditioning and repairs on windmill blades.
- SIZE RANGE:** 3-1/2" x 2-1/8"
- GRIT RANGE:** 60 – 1800
- ABRASIVE TYPES:** Diamond

FEATURED PRODUCTS



FLEXIBLE DIAMOND HAND PADS – CONVENTIONAL AND QUADROFLEX CURVED BETTER CHOICE FOR SHAPING, RAPID STOCK REMOVAL, SURFACE CONDITIONING, TOUCH-UP, AND REPAIR

FEATURES

- Lightweight conformable backing
- Color coded
- Conventional hand pads: precision dot pattern
- Quadraflex curved hand pad

BENEFITS

- Adaptable to a variety of shapes and conditions
- Durable, long life
- Uniform finishes; improved surface quality
- Can be used wet or dry
- No dressing required
- Eases identification
- Aggressive, consistent, fast cut rate, reduces dust and loading
- Ergonomic advantages, overall lower cost

AVAILABILITY

SIZE (L X W)	COLOR	GRIT	STD. PKG.	TIER: BETTER		TIER: BETTER	
				TRADENAME: DIAMOND HAND PADS		TRADENAME: QUADROFLEX HAND PADS	
				ABRASIVE: Diamond		ABRASIVE: Diamond	
				PRODUCT NO.	PART NO.	PRODUCT NO.	PART NO.
3-1/2 x 2-1/8	Green	60	1	HP60	66260306360	QHP60	69014121517
	Black	120	1	HP120	66260306361	QHP120	69014121518
	Red	200	1	HP200A	66260306362	QHP200	69014123529
	Yellow	400	1	HP400	66260305852	QHP400	69014123530
	White	800	1	HP800	66260306363	QHP800	69014123531
	Blue	1800	1	HP1800	66260306364		
	Kit (one each of above)		1	HPK-6	66260307720		



NORTON **SG**
BLAZE

Norzon
BLUEFIRE

NORZON



CATEGORY DEFINITION

Portable file belt sanders have replaced tedious hand filing and sanding. First introduced in pneumatic, they are now available in electric. Increasingly, tool manufacturers are introducing additional fixtures for an increasing number of applications. The belts listed are popular stock sizes, but additional sizes, specifications, backing materials, and edge scallops are available made-to-order.

- APPLICATIONS: Light weld removal and blending, shape and contour sanding, surface preparation prior to coating and plating, removing cutting tool marks from molds and dies, general clean-up and finishing
- SIZE RANGE: 1/8" to 1" wide, 12" to 30" long
- GRIT RANGE: 40 – 120
- ABRASIVE GRAIN: Ceramic Alumina, Zirconia Alumina, Aluminum Oxide

150+ NEW STOCK ADDITIONS!

CROSS REFERENCE GUIDE

	BEST Norton SG Blaze R980P	BEST Norton SG R981	BETTER NorZon R823	GOOD Metalite R283
3M	977F	963G, 967F	577F, 777F	241E
Hermes	CR456	–	RB486 44 Z	RB317J, RB316EJ RB303 Flex
Klingspor	CS610YY	–	CS411YX, CS 409Y	CS310XF
SIA	–	–	–	933A, 936A
VSM	SK840X, SK750X	–	KK715X	KK711T, KK511J

MATERIAL-TO-PRODUCT RECOMMENDATION GUIDE

	HEAVY-DUTY		GENERAL-DUTY
	BEST HIGHEST PRODUCTIVITY LOWEST TOTAL COST	BETTER EXCELLENT BLEND OF PERFORMANCE & PRICE	GOOD CONSISTENT PERFORMANCE LOW INITIAL PRICE
Carbon Steel	Norton SG Blaze R980P	NorZon R823	Metalite R283
Stainless Steel / Alloys	Norton SG Blaze R980P	NorZon R823	Metalite R283
Cast Iron	Norton SG Blaze R980P	NorZon R823	Metalite R283
Brass/Bronze	–	NorZon R823	Metalite R283
Aluminum	–	NorZon R823	Metalite R283

FEATURED PRODUCTS



NEW

NORTON SG BLAZE R980P

BEST FOR STAINLESS, COBALT, CHROME, INCONEL, TITANIUM, MILD AND CARBON STEEL

FEATURES

- Next-generation cooler cutting Norton SG ceramic alumina grain
- Y-wt. polyester waterproof cloth backing
- Improved resin bond system
- Advanced "supersize" grinding lubricant

BENEFITS

- Lasts 50% to 200% longer on mild and carbon steel, stainless, cobalt, chrome, Inconel and titanium
- Cuts 20% faster than the current generation of ceramic alumina grinding belts
- Better metal integrity
- Edge-fray resistance
- Improved body-retention during use for more consistent grinding throughout belt life
- Significantly improved belt life due to exceptional grain adhesion
- Cooler cutting during the life of the belt
- Improved part finish and integrity



FEATURED PRODUCTS



NORZON R823

THE BETTER CHOICE FOR STAINLESS AND CARBON STEEL

FEATURES

- Premium, self-sharpening zirconia alumina
- Durable grain coating
- Strong X-wt. polyester waterproof backing

BENEFITS

- Aggressive abrasive, rapid cut rate
- Strong grain adhesion, longer life
- For moderate- to heavy-pressure applications

AVAILABILITY



TIER:	BEST	BEST	BETTER	GOOD
BRAND:	Norton	Norton	Norton	Norton
TRADENAME:	SG BLAZE R980P	NORTON SG R981	NORZON R823	METALITE R283
ABRASIVE:	Ceramic Alumina	Ceramic Alumina	Zirconia Alumina	Aluminum Oxide
BACKING:	Y-wt. Polyester	Y-wt. Polyester	X-wt. Polyester	X-wt. Rayon
OTHER:	Supersize			

SIZE (W X L)	GRIT	STD. PKG.	PART NO.	PART NO.	PART NO.	PART NO.
12" BELTS						
1/8 x 12	40	50	66254491518	66254491521	66254492520	66254491536
	60	50	66254405345	66254491522	66261093029	
	80	50	66261089479	66254491523	66261093030	66254491537
	120	50	66254491519	66254491524	66224491533	66254491538
1/4 x 12	40	50	66254491520	66254491525	66254492521	66254491539
	60	50	66261196480	78072760823	78072758896	
	80	50	66261063617	66254491526	78072782621	78072766143
	120	50	66261063632	66254491527	78072782622	78172763175
1/2 x 12	40	50	69957398018	66254491528	66254492522	78072727557
	50	50	66261043759	78072718700	66254492523	66254491540
	60	50	69957398019	78072718701	78072728745	78072727555
	80	50	69957398020	78072718702	78072728744	78072727554
	100	50	66261081180	66254491529	66254491534	78072727553
	120	50	66261042909	78072700518	78072728742	78072727552
1 x 12	60	50	66261063641	78072761985	78072753073	78072773813
13" BELTS						
3/8 x 13	60	50	69957345359	78072745459	78072740295	78072732112
	80	50	69957392150	78072774916	78072736062	78072771323
18" BELTS						
1/8 x 18	40	50	66254475211	66254491530	66254492524	66254491541
	60	50	66261080010	78072781570	66254491535	
	80	50	66261089120	78072789083	78072760595	63642594761
	120	50	66254475215	78072789084	63642595221	66254491542
1/4 x 18	40	50	66261027923	66261198953	66254492525	66254491543
	60	50	69957347249	78072774684	78072743583	78072771000
	80	50	69957346155	78072703284	78072753075	78072773921
	120	50	66261085071	78072785655	78072773764	78072773763
1/2 x 18	40	50	69957398021	78072766018	66254444193	78072727561
	60	50	69957398022	78072718704	78072728569	78072727560
	80	50	69957398023	78072718705	78072728568	78072727559
	120	50	66261041384	78072718706	78072728567	78072727558
3/4 x 18	40	50	69957398027	78072762476	66254492526	78072781797
	60	50	69957398028	78072745691	78072709590	78072739966
	80	50	69957398029	78072756309	78072758953	78072732289
20-1/2" BELTS						
3/4 x 20-1/2	40	50	69957398030	78072714398	66254457869	78072727573
	50	50	69957344982	78072718714	66254492527	66254491544
	60	50	69957398031	78072718715	78072728560	78072727571
	80	50	69957398032	78072718716	78072728559	78072727570
	100	50	66261055516	78072771151	66261038911	78072727569
	120	50	66261044755	78072727380	78072728557	78072727575



AVAILABILITY

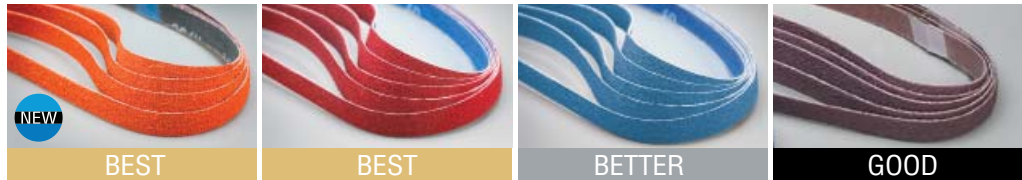

TIER:	BEST	BEST	BETTER	GOOD
BRAND:	Norton	Norton	Norton	Norton
TRADENAME:	SG BLAZE R980P	NORTON SG R981	NORZON R823	METALITE R283
ABRASIVE:	Ceramic Alumina	Ceramic Alumina	Zirconia Alumina	Aluminum Oxide
BACKING:	Y-wt. Polyester	Y-wt. Polyester	X-wt. Polyester	X-wt. Rayon
OTHER:	Supersize			

SIZE (W X L)	GRIT	STD. PKG.	PART NO.	PART NO.	PART NO.	PART NO.
24" BELTS						
1/4 x 24	40	50	66261198631	78072747823	66254473499	66254401929
	60	50	69957345451	78072756534	78072728552	78072727548
	80	50	63642596940	78072718340	78072767713	78072791441
	120	50	66261080367	78072770718	78072728550	78072722137
1/2 x 24	40	50	69957398024	78072760092	66254492528	78072727568
	50	50	66261043757	78072718707	66254452237	78072727567
	60	50	69957398025	78072718708	78072728564	78072727566
	80	50	69957398026	78072718709	78072728566	78072727565
	100	50	66261042203	78072745021	78072753076	66254491545
	120	50	66261042565	78072718710	78072728565	78072727564
1 x 24	40	50	69957350019	66254491531	66254492529	66254491546
	50	50	69957344889	78072710374	66254492530	66254491547
	60	50	69957353375	78072737318	78072798720	66254491548
	80	50	69957345419	78072772209	78072776498	66261085068
	120	50	66261085067	66254491532	78072730029	66261085069
30" BELTS						
1 x 30	40	50	66261053470	78072765229	66254478257	66261189958
	60	50	69957345985	66261198336	78072728583	66254491549
	80	50	69957346105	78072764439	78072728582	78072727579
	120	50	66261193676	78072781197	78072766992	78072727577

ADDITIONAL SIZES, GRITS AND SCALLOPED EDGE BELTS ARE AVAILABLE MTO (MADE-TO-ORDER). PLEASE CONTACT YOUR LOCAL NORTON DISTRIBUTOR TO CHECK AVAILABILITY.

40 AND 50 GRIT NORZON BELTS ARE FURNISHED IN NORZON BLUEFIRE R887 (Y-WT. POLYESTER)

JOINTS AND FLEXES – ALL BELTS ARE PG JOINTED; A BUTT JOINT JOINED WITH FLEXIBLE TAPE FOR CONTOUR GRINDING



Non-Woven File Belts

AVAILABILITY



TIER:	BETTER	GOOD
BRAND:	Norton	Norton
TRADENAME:	STE-VS	STE
ABRASIVE:	Aluminum Oxide	Aluminum Oxide

SIZE (W X L)	GRIT SIZE	STD. PKG.	PART NO.	PART NO.
NON-WOVEN FILE BELTS				
1/2 x 18	Coarse	24	66261009048	66261055309
	Medium		66261008814	66261055310
	Very Fine		66261006762	66261055311
1/2 x 24	Coarse	24		66261055312
	Medium		66261008972	66261055313
	Very Fine			66261055314
3/4 x 18	Coarse	24	66261008813*	08834194006
	Medium		66261006546*	08834194007
	Very Fine			08834194008
3/4 x 20-1/2	Coarse	24		08834194009
	Medium			08834194010
	Very Fine			08834194011

*12 PER STANDARD PACKAGE

Norton non-woven file belts are ideal for light finishing, blending, cleaning and polishing applications on all materials.

STE-VS – have a firmer backing and more aggressive cut rate for blending and finishing

STE – have a more conformable backing and more open structure, and are designed for cleaning and polishing



CATEGORY DEFINITION

Portable belts are ideal for all your metal and woodworking applications. Choose 36 – 50 grits for rough/heavy-duty applications, 60 – 100 for intermediate, and 100 – 220 for finishing/polishing applications. Stock is available for wood applications and FastTrack service is used for all other applications.

APPLICATIONS:	Grinding and finishing all metals, blending welds, sanding and finishing wood, glass seaming, and polishing
SIZE RANGE:	3" to 4" wide, 15-1/2" to 24" long
GRIT RANGE:	36 – 220
ABRASIVE GRAIN:	Ceramic Alumina, Zirconia Alumina, Aluminum Oxide

CROSS REFERENCE GUIDE

<i>NORTON</i>	BEST Norton SG Blaze R980P	BETTER NorZon R811	GOOD Metalite R215/R228
3M	977F, 967F, 963G	777F, 577F	241D, 340D
Hermes	RB346MX	RB484Z	RB316XOP
Klingspor	CS610YY	CS411Y	CS311YX, CS310X, LS309XH
Sait	–	ZH	AOX, IAX
SIA	–	–	2903XO, 2905X, 2920X
VSM	SK855X	ZK713X	KK511X, KK711X, KK504X

MATERIAL-TO-PRODUCT RECOMMENDATION GUIDE

	HEAVY-DUTY		GENERAL-DUTY
	BEST HIGHEST PRODUCTIVITY LOWEST TOTAL COST	BETTER EXCELLENT BLEND OF PERFORMANCE & PRICE	GOOD CONSISTENT PERFORMANCE LOW INITIAL PRICE
Wood	–	NorZon R811	Metalite R215
Stainless Steel / Carbon Steel	Norton SG Blaze R980P	NorZon R824	Metalite R228
Brass / Bronze / Aluminum	–	NorZon R811	Metalite R215

FEATURED PRODUCTS



NORTON SG BLAZE R980P

BEST FOR STAINLESS, COBALT, CHROME, INCONEL, TITANIUM, MILD AND CARBON STEEL

FEATURES

- Next generation cooler cutting Norton SG ceramic abrasive grain
- Y-wt. polyester waterproof cloth backing
- Improved resin bond system
- Advanced "supersize" grinding lubricant

BENEFITS

- Lasts 50% to 200% longer on mild and carbon steel, stainless, cobalt, chrome, Inconel and titanium
- Cuts 20% faster than the current generation of grinding belts
- Better metal integrity
- Greater productivity; lowest total grinding costs
- Edge-fray resistance
- Improved body retention during use for more consistent grinding throughout belt life
- Significantly improved belt life due to exceptional grain adhesion
- Cooler cutting during the life of the belt
- Improved part finish and integrity



NORZON R811

THE BETTER CHOICE FOR STAINLESS STEEL

FEATURES

- Premium, self-sharpening zirconia alumina
- Reversible butt splice
- Open-coat design, strong Y-wt. cotton backing

BENEFITS

- Aggressive abrasive, rapid cut rate, long life
- Use in either direction for longer life
- Reduced loading, extended life



Portable Belts for Belt Sanders

Portable electric belt sanders are used on wood, metal, and other materials, for applications ranging from stock removal to finishing. They consist of an electrical motor that turns a pair of drums on which an abrasive belt is mounted.

Belt sanders can be either hand-held, where the sander is moved over the material, or stationary (fixed), where the material is brought to the sanding belt.



AVAILABILITY

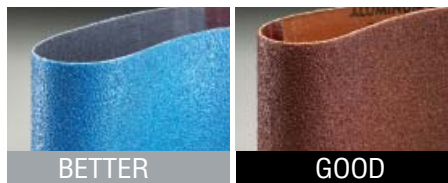

TIER:	BETTER	GOOD
BRAND:	Norton	Norton
TRADENAME:	NORZON R811	METALITE R215
ABRASIVE:	Zirconia Alumina	Aluminum Oxide
JOINT:	Plyweld	Plyweld
GRAIN COATING:	Open Coat	Open Coat

SIZE W X L	GRIT	MIN./ STD. PKG.	PART NO.	PART NO.
3 x 18	36	5/25		07660702353
	50		07660749259	07660700964
	80		07660749258	07660700968
	120		07660749256	07660700969
3 x 21	36	5/25	07660749266	07660701741
	50		07660749265	07660701740
	80		07660749264	07660702064
	100		07660749263	07660702063
	120		07660749262	07660702062
	220		07660749262	07660705287
3 x 24	36	5/25	07660749272	07660701743
	50		07660749271	07660701742
	80		07660749270	07660702067
	100		07660749269	07660702066
	120		07660749268	07660702065
	220		07660705286	
4 x 24	36	5/25	07660749278	07660701745
	50		07660749277	07660701744
	80		07660749276	07660702069
	100		07660749275	
	120		07660749274	07660702068
	180		07660705285	

Portable Belts for Pneumatic In-Line Drum Sanders



AVAILABILITY



TIER:	BEST	BEST	GOOD
BRAND:	Norton	Norton	Norton
TRADENAME:	SG BLAZE R980P	NORTON SG R981	METALITE R215
ABRASIVE:	Ceramic Alumina	Ceramic Alumina	Aluminum Oxide
JOINT:	Plyweld	Plyweld	Plyweld
GRAIN COATING:	Close Coat / Supersize	Close Coat / Supersize	Open Coat

SIZE W X L	GRIT	MIN./ STD. PKG.	PART NO.	PART NO.	PART NO.
3-1/2 x 15-1/2	36	10/50		78072700783	78072721997
	60			78072718750	78072722000
	80		63642593514	78072718751	78072721995
	120			78072718753	



CATEGORY DEFINITION

A wide selection of sizes and grits for most dimensioning, intermediate grinding and polishing applications.

APPLICATIONS: Benchstand and Backstand Belts: grinding and deburring of all metals, heavy stock removal, blending, dimensioning and shaping, polishing.
Centerless, Conveyor and Platen Belts: intermediate grinding stainless and carbon, moderate-pressure applications, dimensioning and finishing.

SIZE RANGE: 1" to 10" wide, 36" to 132" long

GRIT RANGE: 36 – 320

ABRASIVE GRAIN: Ceramic Alumina, Zirconia Alumina, Aluminum Oxide

200+ NEW STOCK ADDITIONS!

CROSS REFERENCE GUIDE

NORTON	BEST NORTON SG R980P	BEST NORTON SG R981	BETTER NORZON R801	BETTER NORZON R821	BETTER NORZON R823	BETTER NORZON R824	GOOD METALITE R228
3M	987F1, 977F, 777F, 967F, 963G, 963H	987F1, 977F, 777F, 967F, 963G, 963H	577F, 567G, 777F 977F	561D	561F Y, 551E XE 741A, 741E, 761D	561D, 561F, 563F 741A, 741E, 761D 761F	240DZ OPK, 270DZ OPK, 241D, 248D, 251D, 341I Imperial, 351D
Hermes	CR456	CR456	RB486X, RB486Y RB426-23MX	–	RB486 X, RB346-23MX RB426-23MX, RB484TY RB486XF	RB484TY, RB486Y, RB346-23MX, RB426-23MX RB480-21MX, CB440Y, RB486XY	RB3160P RB317LX RB346MX
Klingspor	CS612YY, CS610YY	CS612YY, CS610YY	CS409Y	CS411Y	CS411X	CS411Y	CS311X, CS310, CS410
SIA	–	–	–	–	–	2800, 2803, 2929	2903X0, 2905X, 2920X
VSM	SK840X, SK750X	SK840X, SK750X	KK815Y, ZK744X	–	KK715X	KK716Y, ZK713X	KK511X, KK711

MATERIAL-TO-PRODUCT RECOMMENDATION GUIDE

	BEST HIGHEST PRODUCTIVITY LOWEST TOTAL COST	BETTER EXCELLENT BLEND OF PERFORMANCE & PRICE	GOOD CONSISTENT PERFORMANCE LOW INITIAL PRICE
Aluminum	–	NorZon R824/R823	Metalite R228
Cast Iron	Norton SG Blaze R980P	NorZon R824/R823	Metalite R228
Brass / Bronze	–	NorZon R824/R823	Metalite R228
Die Castings	Norton SG Blaze R980P	NorZon R824/R823	Metalite R228
Carbon Steel	Norton SG Blaze R980P	NorZon R824/R823	Metalite R228
Glass / Ceramics	Norton SG Blaze R980P	NorZon R821	Durite R480
Stainless Steel and Alloys	Norton SG Blaze R980P	NorZon R824/R823 NorZon R801	Metalite R228
Wood	–	NorZon R811	Metalite R215

GRIT SELECTION RECOMMENDATION GUIDE





FEATURED PRODUCTS



NEW

NORTON SG BLAZE R980P

BEST FOR MILD AND CARBON STEEL, STAINLESS, COBALT, CHROME, INCONEL, TITANIUM

FEATURES

- Next-generation cooler cutting SG ceramic abrasive grain
- Y-wt. polyester waterproof cloth backing
- Improved resin bond system
- Advanced “supersize” grinding lubricant

BENEFITS

- Lasts 50% to 200% longer on mild and carbon steel, stainless, cobalt, chrome, Inconel and titanium
- Cuts 20% faster than the current generation of grinding belts
- Longer belt life
- Better metal integrity
- Greater productivity; lowest total grinding costs
- Edge-fray resistance
- Improved body retention during use for more consistent grinding throughout belt life
- Significantly improved belt life due to better grain adhesion
- Cooler cutting during the life of the belt
- Improved part finish and integrity



NORTON SG R981

EXCEPTIONAL PERFORMANCE, ESPECIALLY ON HARD-TO-GRIND ALLOYS

FEATURES

- Norton SG ceramic abrasive
- Grinding-aid enhanced
- Strong Y-weight polyester, waterproof cloth backing

BENEFITS

- Exceptional life and value, especially on hard-to-grind alloys
- Longer life, cooler cut
- Improved grain adhesion, reduced edge-fray and better body retention, result in longer life and product consistency



NORZON R821

THE BETTER CHOICE FOR NONFERROUS METALS, GLASS, AND CERAMICS

FEATURES

- Premium self-sharpening zirconia alumina abrasive
- Durable grain coating
- Y-weight cotton backing

BENEFITS

- Aggressive, rapid cut rate
- Excellent grain adhesion: longer life
- Extended life on dry grinding applications



NORZON R824/R823

BETTER CHOICE FOR HEAVIEST-PRESSURE APPLICATIONS

FEATURES

- Premium self-sharpening zirconia alumina abrasive
- R824 – Durable Y-weight polyester, waterproof cloth backing
- R823 – Strong X-weight polyester backing; waterproof

BENEFITS

- Aggressive, rapid cut rate
- Excellent grain adhesion, reduced edge-fray and better body retention, result in longer life and product consistency
- More flexible than R824
- Available in finer grit sizes

TECHtip

TROUBLESHOOTING GUIDE

PROBLEM

CORRECTION

Loading

Decrease infeed pressure or belt speed

Shedding

Reduce applied pressure
Use a less aggressive contact wheel
Dress contact wheel if worn or damaged
Use entire surface of belt





Belt breakage

Reduce belt tension
Use less aggressive contact wheel
Check tracking mechanism for belts tracking erratically



Benchstand Belts – 1" to 6" wide, 36" to 72" long

AVAILABILITY





						
			BEST	BETTER	BETTER	GOOD
TIER:			Norton	Norton	Norton	Norton
BRAND:			SG BLAZE R980P	NORZON R821	NORZON R823	METALITE R228
TRADENAME:			Ceramic Alumina	Zirconia Alumina	Zirconia Alumina	Aluminum Oxide
ABRASIVE:			Y-wt. Polyester	Y-wt. Cotton	X-wt. Polyester	X-wt. Cotton
BACKING:						
SIZE (W X L)	GRIT	MIN./STD. PKG.	PART NO.	PART NO.	PART NO.	PART NO.
1 x 42	36	50/200	66254476825			78072791710
	40		69957345887	78072726905		78072720910
	50		66254476826	78072726904		78072720905
	60		69957345486	78072726903	78072728596	78072720900
	80		66261041539	78072726902	78072728594	78072720895
	100		66261043462		78072728592	78072720890
	120		66261038660		78072728590	78072720885
	150				78072728588	78072720880
	180				78072728586	78072720875
	220				78072700001	78072720871
	240					78072720870
	320					78072720865
1-1/2 x 60	36	10/50	69957345578			78072721060
	40		63642595003			78072721055
	50		69957345664	78072726991		78072787807
	60		69957345631	78072726990		78072721045
	80		69957345579		78072726988	78072721040
	100				78072765077	69957351736
	120		66261056493		78072726984	78072721030
	220				78072758464	78072722855
				78072708871	78072756615	
2 x 48	24	10/50		78072727103		78072726130
	36		63642592057	78072727102		78072721255
	40		69957345193	78072727101		78072721250
	50		69957346716	78072727100	78072728621	78072721245
	60		69957344423	78072727099	78072728619	78072721240
	80		69957345100		78072728617	78072721235
	100		66261052522		78072728615	78072721230
	120		66261052520		78072728613	78072721225
	150				78072728611	78072723246
	180				78072728609	78072721223
	220					78072763677
	320					78072746387
2 x 60	24	10/50				66261054787
	36		69957345196			78072701170
	40		69957394425	78072727124		78072721300
	50		69957346149			78072762537
	60		69957344901	78072727122		78072721290
	80		63642592574	78072727121		78072721285
	100		66261052222		66261082976	78072721280
	120		66261042738		78072761958	78072721275
	150					78072744018
	180				78072702695	78072720441
	220				78072706282	78072744020
	320					78072761862
				78072702825		
2 x 72	24	10/50	66254433969			
	36		69957345460	78072727147		78072721335
	40		69957346729	78072727146		78072721332
	50		69957344966	78072727145		78072784894
	60		69957345157	78072727144	78072728645	78072721325
	80		69957344961	78072727142	78072728643	78072721320
	100		66261041897		66261025537	78072723235
	120		66261044095		78072728639	78072721318
	150				78072761770	78072761973
	180				78072763853	78072718488
	220				78072728633	78072765601
	320					78072721308

CONTINUED



Benchstand Belts – 1" to 6" wide, 36" to 72" long CONTINUED

AVAILABILITY

						
			BEST	BETTER	BETTER	GOOD
TIER:			Norton	Norton	Norton	Norton
BRAND:			SG BLAZE R980P	NORZON R821	NORZON R823	METALITE R228
TRADENAME:			Ceramic Alumina	Zirconia Alumina	Zirconia Alumina	Aluminum Oxide
ABRASIVE:			Y-wt. Polyester	Y-wt. Cotton	X-wt. Polyester	X-wt. Cotton
BACKING:						
SIZE (W X L)	GRIT	MIN./STD. PKG.	PART NO.	PART NO.	PART NO.	PART NO.
2-1/2 x 48	36	10/50				78072721540
	50			78072727213		78072721530
	60					78072721525
	80					78072721520
2-1/2 x 60	24	10/50				78072708296
	36		69957344963	78072727235		78072721610
	40		69957346523	78072727234		78072721605
	50		69957345300	78072727233		78072721600
	60		69957345002	78072727232	78072728692	78072721595
	80		69957346095	78072727231	78072728690	78072721590
	100		66261041380			78072721585
	120		66261041379		78072728686	78072721580
	150					78072710118
	180				78072728682	78072721570
	220				78072778217	78072721565
	4 x 36		36	10/50		
40						78072722105
50			78072727475			78072722100
60			78072727474		78072728827	78072722095
80			78072727473		78072728825	78072722090
100					78072728823	78072722085
120					78072728821	78072722080
150						78072722079
180						78072722075
240						78072722926
320						78072722071
4 x 54	36	10/50	69957346358			78072722185
	40		63642594113			78072722180
	50		66254469595			78072722175
	60		66261063419	78072727518	78072725116	78072722170
	80		69957345139		78072782996	78072722165
	100					78072722160
	120		66261088705		78072728847	78072722155
	150				78072789676	78072728381
	180				66254475370	78072759243
220			78072762311	78072762536		
4 x 60	24	10/50	66254461488			78072772342
	36		69957345298			78072705189
	40		69957391732			78072744693
	50		69957346715			78072761630
	60		63642594485		78072774790	78072762861
	80		69957345099		78072765086	78072784685
	100					78072763161
	120		66254416188		78072766229	78072787840
	150				66254482609	78072704878
	180				78072709820	78072728393
	220				78072702594	78072790168
6 x 48	36	10/20	69957345143	78072727698		78072722590
	40			78072727697		78072722585
	50			78072727696		78072722580
	60	20/20	69957344422	78072727695	78072728937	
	80			78072727694	78072728935	78072722570*
	100				78072728933	78072722565*
	120				78072728931	78072722560*
	150				78072770042	78072722555*
	180					78072722550*
	220					78072722546*
	240					78072722545*
	320					78072722543*

* MIN./STD. PKG. IS 10/50

CONTINUED



Benchstand Belts – 1" to 6" wide, 36" to 72" long CONTINUED

AVAILABILITY

						
			BEST	BETTER	BETTER	GOOD
<i>TIER:</i>			Norton	Norton	Norton	Norton
<i>BRAND:</i>			SG BLAZE R980P	NORZON R821	NORZON R823	METALITE R228
<i>TRADENAME:</i>			Ceramic Alumina	Zirconia Alumina	Zirconia Alumina	Aluminum Oxide
<i>ABRASIVE:</i>			Y-wt. Polyester	Y-wt. Cotton	X-wt. Polyester	X-wt. Cotton
<i>BACKING:</i>						
<i>SIZE (W X L)</i>	<i>GRIT</i>	<i>MIN./STD. PKG.</i>	<i>PART NO.</i>	<i>PART NO.</i>	<i>PART NO.</i>	<i>PART NO.</i>
6 x 60	36	10/20		78072727762		78072722680
	40					78072722679
	60	20/20	69957345149		78072728957	78072722665
	80				78072728955	78072722660
	100		66254477452			
	120					78072763882

Belt Cleaning Stick



- This solid, rubber cleaning stick is designed to remove wood and other non-metallic materials that build up on belt surface during use.
- Apply it to the face of the belt, while running, to remove unwanted materials and prolong the overall life of the belt up to 10 times.

<i>DESCRIPTION</i>	<i>STD. PKG.</i>	<i>PART NO.</i>
1-3/8 x 1-3/8 x 6	10	07660701717

TECHtip

A light bodied grease applied to a benchstand belt surface will reduce loading and greatly enhance the belt life and performance when grinding soft, malleable nonferrous materials such as aluminum, brass, bronze and copper.



Backstand Belts – Over 72" Long

AVAILABILITY



TIER:	BEST	BEST	BETTER	BETTER	GOOD
BRAND:	Norton	Norton	Norton	Norton	Norton
TRADENAME:	SG BLAZE R980P	SG R981	NORZON R824	NORZON R823	METALITE R228
ABRASIVE:	Ceramic Alumina	Ceramic Alumina	Zirconia Alumina	Zirconia Alumina	Aluminum Oxide
BACKING:	Y-wt. Polyester	Y-wt. Polyester	Y-wt. Polyester	X-wt. Polyester	X-wt. Cotton

SIZE (W X L)	GRIT	MIN./STD. PKG.	PART NO.	PART NO.	PART NO.	PART NO.	PART NO.	
2 x 132	36	10/50		78072753086	78072750016	78072721470		
	40				78072750015			
	50				78072750013			
	60				78072750011			
	80				78072750008			
	120				78072728662			
3 x 132	24	25/50	69957344962	78072753087*	78072750140*	78072721900		
	36		69957344710		78072750138* RR			
	36				78072750139* L			
	40		69957344964		78072701614*			
	50		69957344763		78072703709*			
	60		69957344958		78072750135*			
	80		69957344764					78072728794
	100				78072728792			
	120				78072728790			
	150				78072728789			
	180				78072728785			
	220							78072721890
4 x 132	24	10/50	69957343852	78072739662	78072750289	78072722400		
	36				78072750287			
	40							
	60				78072750281			
	80				78072750279			
	120							
8 x 107	36	10/20				78072722795	78072722773	
	50							
	60							
	80	20/20						78072749887
	80							78072722780
	100							78072722775
10 x 70-1/2	36	5/10				78072722840	78072722820	
	40							
	50							
	60	10/10						78072722835
	80							78072722830
	80							78072722825

* MIN./STD. PKG. IS 10/50

FastTrack Belt Service

For non-stock belts, FastTrack Service Centers offer all the benefits of an ISO 9001 quality manufacturer and the advantages of a coated abrasives express belt service. As the industry's leading producer of abrasive material and backings, our FastTrack service offers an extensive range of Norton made-to-order belts including Norton SG ceramic alumina, NorZon zirconia alumina, and versatile aluminum oxide and silicon carbide belts.

Also available in FastTrack are a full line of Merit brand belts. Merit belts have been developed with one simple goal in mind: to provide you economically-priced ceramic alumina, zirconia alumina, and aluminum oxide belts to meet a wide range of applications.

Manufacturing lead-time is two days for narrow belts (1/2"- 12") and three days for wide belts =>14". Please see the FastTrack belt section for complete availability and lead-times.



WIDE BELTS CLOTH AND HEAVY PAPER



CATEGORY DEFINITION

A selection of stock products to meet wide belt needs in the woodworking and metalworking industries.

APPLICATIONS: Metalworking wide belts are used for plate dimensioning, slag grinding, machining, deburring, and other general metalworking applications. They are usually cloth and are closed coat.

Cloth woodworking wide belts are used for rough stock removal and dimensioning; paper woodworking belts are used to upgrade the finish on furniture and other wood components.

SIZE RANGE: Stock: 25" – 52" wide, 48" to 103" long

GRIT RANGE: Stock: 36 – 220

ABRASIVE GRAIN: Ceramic Alumina, Zirconia Alumina, Aluminum Oxide

AVAILABILITY: Due to the wide varieties of machines and applications, the majority of wide belts are non-stock. FastTrack service is available on the majority of products with 3-day lead-time on orders up to two standard packages.

METALWORKING CLOTH BELT RECOMMENDATION GUIDE/CROSS REFERENCE

	TOTAL PERFORMANCE					INITIAL PRICE		
	BEST HIGHEST PRODUCTIVITY LOWEST TOTAL COST		BETTER EXCELLENT BLEND OF PERFORMANCE & PRICE			GOOD CONSISTENT PERFORMANCE LOW INITIAL PRICE		
	H-wt. Poly	Y-wt. Poly	H-wt. Poly	Y-wt. Poly	X-wt. Poly	Y-wt. Poly	X-wt. Poly	X-wt. Cotton
NORTON	R940P	R980P	R840	R887/R884	R823	R247	R249	R228
MERIT		SY965		SY695	SX695	SY395	SX395	KX375
3M	963G,H	977F, 967F		577F, 777F		361F	353F	241D, 341D
Ekamant				UZA0X	UZA0X	UA0X	UA0X	MKX, RKX
Hermes	CB441Z	CR456	SB488Y OP	RB484TY	RB486	RB376TY	RB376TY	RB346MX
Klingspor		CS610YY	CS414YY	CS411Y	CS411Y	CS412Y	CS412Y	CS310X
SIA			C888 DP	2800, 2803		2982		2920, 2912
VSM	SK770X, SK847Y	SK840X	KK717Y	KK716Y	KK715X	KK711Y	KK711X	KK511X

WOODWORKING CLOTH BELT RECOMMENDATION GUIDE/CROSS REFERENCE

	TOTAL PERFORMANCE				INITIAL PRICE		
	BEST HIGHEST PRODUCTIVITY LOWEST TOTAL COST		BETTER EXCELLENT BLEND OF PERFORMANCE & PRICE		GOOD CONSISTENT PERFORMANCE LOW INITIAL PRICE		
	Y-wt. Cotton Dust-Less	F-wt. Paper Dust-Less	Y-wt. Cotton	Y-wt. Cotton Dust-Less	X-wt. Cotton	F-wt. Paper Dust-Less	F-wt. Paper Dust-Less
NORTON	R989	H968	R811	R216	R215		
MERIT			KY685		KX395	P55F	P55FOP
3M	970DZ	961UZ	777F	240D, 248D, 370DZ	240DZ, 340D	260UZ	241
Ekamant					PKX, RKX		PKFO, APKFO
Hermes		CB115	RB484TY, RB346MX	RB316YOP, RB372YOP	RB316XOP	BW112	BW114
Klingspor			CS414Y, SMT624	CS412, CS311Y	CS3110C	PS26	PS20
SIA	2829	1919	2803, 2820, 2829	2918, 2920, 2928	2928, 2920	1919FO	1939
VSM			KK716X	KK711Y, KK524Y	KK504X	KK508E	KP709

FEATURED PRODUCTS



NORZON R824/R823/R811 CLOTH BELTS

BETTER CHOICE FOR ALL METAL AND WOOD APPLICATIONS DUE TO THE CUT RATE AND LIFE OF THE PROPRIETARY NORTON NORZON GRAIN

FEATURES

- Premium self-sharpening zirconia alumina abrasive
- R824 – Durable Y-wt. polyester, waterproof cloth backing
- R823 – Strong X-wt. polyester, waterproof cloth backing
- R811 - Y-wt. cotton cloth backing

BENEFITS

- Aggressive cut and long life
- Long life on high-pressure, dry or wet, heavy-duty metal applications
- Moderate flexibility, dry or wet, fine grit applications
- Durable open coat cotton belt designed for excellent stock removal on wood with limited loading

AVAILABILITY CLOTH WIDE BELTS

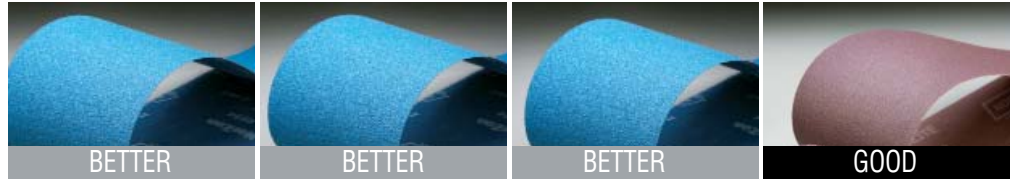

TIER:	BETTER	BETTER	BETTER	GOOD
TRADENAME:	NORZON R824	NORZON R823	NORZON R811	METALITE R215
ABRASIVE:	Zirconia Alumina	Zirconia Alumina	Zirconia Alumina	Aluminum Oxide
BACKING:	Y-wt. Polyester Cloth	X-wt. Polyester Cloth	Y-wt. Cotton Cloth	X-wt. Cotton Cloth
JOINT/FLEX:	Plyweld, RR	Plyweld, RR	Plyweld, RR	Plyweld, RR

SIZE (W X L)	GRIT	MIN./STD. PKG.	PART NO.	PART NO.	PART NO.	PART NO.
25 x 48	80	3/3		69957344781		
25 x 60	80	3/3		69957328117		
	120	5/5		69957328115		
25 x 75	120	5/5		69957344791		
36 x 75	36	2/2	69957350934			
	50	3/3			69957328320	
	60	3/3	69957350931			
	80	3/3			69957328317	69957323872
	100	5/5				69957323871
	120	5/5		69957329014		69957323870
	150	5/5				69957323869
37 x 60	180	5/5		69957344869		
	50	3/3	69957306219			
	80	3/3		69957329019		69957325709
	100	5/5		69957328103		69957325708
	120	5/5		69957329018		69957325707
	150	5/5		69957328102		69957302955
	180	5/5		69957328101		
37 x 75	220	5/5		69957328100		
	36	2/2	69957350959			
	50	3/3	69957305107			69957325957
	80	3/3	69957350955			69957323880
	100	5/5			69957307358	69957325760
	120	5/5				69957305737
	150	5/5				
180	5/5		69957306734			
50 x 103	36	2/2			69957328027	
	60	3/3			69957328385	
	80	3/3			69957328383	
	100	5/5				69957325795
	120	5/5				69957325790
52 x 103	36	2/2				69957325786
	80	3/3			69957328082	
	120	5/5				69957305904
						69957306968

FEATURED PRODUCTS



NORTON SG H968 HEAVY PAPER BELTS

BEST CHOICE FOR HIGH PERFORMANCE SANDING OF WOOD WHERE DURABILITY OF CLOTH IS NOT NEEDED

FEATURES

- P-graded Norton seeded-gel ceramic abrasive, F-wt. backing
- Antistatic properties
- Semi-open coat

BENEFITS

- Longest life; greatest productivity; most cost-effective
- High performance cutting; dust-free environment
- Excellent load resistance

AVAILABILITY PAPER WIDE BELTS



TIER:	BEST
TRADENAME:	H968
ABRASIVE:	Ceramic Alumina
BACKING:	F-wt. Paper
JOINT/FLEX:	Channel, RR
OTHER:	P-Graded

SIZE (W X L)	GRIT	MIN./STD. PKG.	PART NO.
37 x 75	80	3/3	69957327784
	100	5/5	69957327785
	150	5/5	69957327787
	180	5/5	69957327788
52 x 103	80	3/3	69957327778
	100	5/5	69957327779
	220	5/5	69957327783

TECHtip

- 36" wide belts can be used on machines that normally use 37" wide belts.



FastTrack Belt Service

For non-stock belts, our FastTrack Service Centers offer all the benefits of an ISO 9001 quality manufacturer and the advantages of a coated abrasives express belt service. As the industry's leading producer of abrasive material and backings, our FastTrack service offers an extensive range of Norton made-to-order belts including Norton SG ceramic alumina, NorZon zirconia alumina, and versatile aluminum oxide and silicon carbide belts.

Also available in FastTrack are a full line of Merit brand belts. Merit belts have been developed with one simple goal in mind: to provide you economically-priced ceramic alumina, zirconia alumina, and aluminum oxide belts to meet a wide range of applications.

Manufacturing lead-time is two days for narrow belts (1/2"- 12") and three days for wide belts =>14". Please see the FastTrack belt section for complete availability and lead-times.



CATEGORY DEFINITION

NORaX belts outlast conventional abrasive belts with 2 - 5 times longer life. Longer life, higher quality finishes, faster cut rates, and the ability to skip finishing steps all help drive down the costs of your finishing processes.

- APPLICATIONS: Polishing and finishing
- SIZE RANGE: Stock: 1/8" to 1" wide, 12" to 30" long
- GRIT RANGE: Stock: X200 and X100
- ABRASIVE GRAIN: Stock: Ceramic Alumina

FEATURED PRODUCTS



NORAX U936 BELTS

BEST FOR HIGH-PRESSURE PRECISION APPLICATIONS

FEATURES

- Unique, engineered quad surface pattern
- 100% high-performance, micron-graded, cool-cutting Norton SG ceramic alumina abrasive grain
- Improved resin bond system
- Premium, Y-weight polyester waterproof backing
- Fray-resistant backing

BENEFITS

- More abrasive contact area
- Higher cut rates while maintaining more consistent finishes
- Up to more than 2X the life vs. competitive engineered ceramic belts
- Lower specific grinding energy
- Increased durability
- Durable; stands up to high-pressure, coolant applications
- Shred-free

AVAILABILITY

TIER:	BEST	BEST
BRAND:	Norton	Norton
TRADENAME:	NORAX U936	NORAX U936
ABRASIVE:	Ceramic Alumina	Ceramic Alumina
BACKING:	Y-wt. Polyester W/P	Y-wt. Polyester W/P
JOINT/FLEX:	Plyweld, TF	Plyweld, TF
GRIT SIZE:	X200	X100

SIZE W X L	MIN./STD. PKG.	PART NO.	PART NO.
1/4 x 12	50	66623300249	66623300261
1/2 x 12	50	66623300245	66623300258
1 x 12	50	66623300240	66623300255
1/4 x 18	50	66623300250	66623300262
1/2 x 18	50	66623300247	66623300259
3/4 x 18	50	66623300253	66623300264
3/4 x 20-1/2	50	66603300254	66623300265
1/4 x 24	50	66623300252	66623300263
1/2 x 24	50	66623300248	66623300260
1 x 24	50	66623300243	66623300256
1 x 30	50	66623300244	66623300257

Call your local Norton distributor or sales representative for information on additional NORaX belt sizes and specifications.

NORAX VERSUS FEPA GRADING

NORaX engineered abrasives perform over a wider range of traditional grit sequences.

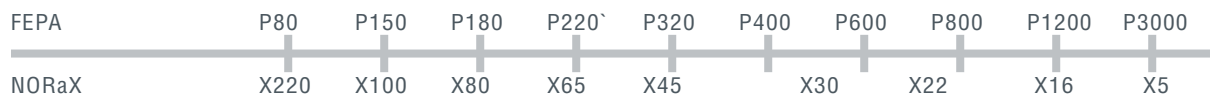



CATEGORY DEFINITION

For many non-stock belts, FastTrack Service Centers offer all the benefits of an ISO 9001 quality manufacturer and the advantages of a coated abrasives express belt service. As the industry leader of abrasive belts, our FastTrack Service offers an extensive range of Norton made-to-order belts including Norton SG ceramic alumina, NorZon zirconia alumina, versatile aluminum oxide, and silicon carbide belts.

Also available in FastTrack are a full line of Merit brand belts. Merit belts have been developed with one simple goal in mind: to provide you economically-priced ceramic alumina, zirconia alumina, and aluminum oxide belts to meet a wide range of applications.

Manufacturing lead-time is two days for narrow belts (1/2" – 12" wide) and three days for wide belts (14 – 52" wide). Please see the FastTrack chart below for complete details on availability and lead-times.

NEW! 3-DAY LEAD-TIME FOR WIDE BELTS!

FASTTRACK AVAILABILITY AND LEADTIME INFORMATION

WIDTH	GRIT SIZE	MINIMUM FASTTRACK BELT ORDER (EQUALS 1 MIN./STD. PKG.)	MAXIMUM FASTTRACK BELT ORDER (EQUALS 2 STD. PKG.)	CONVERSION LEAD-TIME
Narrow Belts				
1/2" through 1"	All	50*	400*	2
Over 1" through 14"	All	10	20	2
Wide Belts				
Over 14" through 20"	All	5	10	3
Over 20" through 52"	36 and Coarser	2	4	3
Over 20" through 52"	40 - 80	3	6	3
Over 20" through 52"	100 and Finer	5	10	3

* 1/2" UP TO 1" BELTS: MIN .PKG. CONTINUES TO BE 50 BELTS AND STD. PKG. = 200 BELTS

HOW TO ORDER

- Indicate "FastTrack belt order" on your order
- Obtain/provide a part number to ensure quick order entry
- Provide a full description of belt required, including:
 - Quantity, size, and specification (abrasive/CAP Code, grit size, flex, and joint)
- Verify that quantity is within FastTrack order limits

FASTTRACK STANDARD BELT JOINT AND FLEX INFORMATION

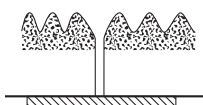

BJ (Butt Joint) – A conventional butt joint with an extra strong patch to eliminate joint breakage. Can be straight or wave.

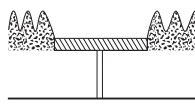

CJ (Channel Joint) – Preferred for woodworking. Supplied on selected F-wt. wide paper belts only. The patch material is inlaid into the top of the belt, making the thinnest, smoothest-running butt joint possible, which minimizes bumping and chattering, with no loss of strength.



RR (Single Flex)

- Flex lines are perpendicular (90° angle) to the edge of the belt, creating a horizontal line pattern, providing flexibility in the lengthwise direction

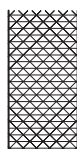

TF (Triple Flex)

- A combination of Single Flex and Double Flex
- It is specified on applications requiring maximum product conformability

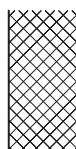

CF (Cross Flex)

- Flex lines are at a 45° angle to the edge of the belt, making a series of diamond-shaped lines.

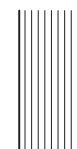

LF (Linear Flex)

- The bond is broken in the direction of the belt length, providing good product conformability with long life



BELT SPECIFICATIONS AND AVAILABILITY

TIER	PRODUCT CAP CODE	SHAPE AVAILABILITY	GRIT SIZE	ABRASIVE GRAIN	BACKING	STANDARD JOINT	STANDARD FLEX	APPLICATIONS
METALWORKING								
NORTON								
Best	R980P	Narrow, Wide	24-120	Norton SG Ceramic Alumina	Y-wt. Polyester	BJ	RR	Latest-generation Norton SG grain, supersized and designed for high-performance grinding on stainless and other alloys
Best	R984	Narrow, Wide	36-120	Norton SG Ceramic Alumina	Y-wt. Polyester	BJ	RR	Norton SG grain supersized for medium-pressure grinding and finishing heat-sensitive alloys
Better	R884	Narrow, Wide	24, 36-80	NorZon Zirconia Alumina	Y-wt. Polyester	BJ	RR	Newest-generation NorZon grain designed for medium- to high-pressure grinding
Better	R887	Narrow, Wide	24, 36-120	NorZon Zirconia Alumina	Y-wt. Polyester	BJ	RR	Newest-generation NorZon grain, supersized and designed for medium- to high-pressure grinding of heat-sensitive alloys
Better	R823	Narrow, Wide	60-220	NorZon Zirconia Alumina	X-wt. Polyester	BJ	RR	NorZon grain on lighter backing designed for light to medium grinding
Good	R222	Narrow	P80-P320, P400, P600	Aluminum Oxide	J-wt. Cotton	BJ	TF	Aluminum oxide on flexible, lightweight cotton backing for moderate- to light-pressure applications on mild steel
Good	R245	Narrow	P80-P240, P320, P400	Aluminum Oxide	J-wt. Polyester	BJ	LF	Aluminum oxide on flexible, lightweight polyester backing for moderate- to light- pressure applications on mild steel
Good	R445	Narrow	60-220	Silicon Carbide	X-wt. Polyester	BJ	RR	Sharp, silicon carbide grain on medium polyester backing for grinding very hard materials – glass, stone, solid surface
Good	U242	Narrow, Wide to 24"	X4, X16, X22, X30, X45, X65	Aluminum Oxide	J-wt. Cotton	BJ	CF	High-performance, multi-layered NORaX grain on very flexible backing for dry polishing applications
MERIT								
Best	SY965	Narrow, Wide	36-120	Ceramic Alumina	Y-wt. Polyester	BJ	RR	Ceramic alumina grain supersized for medium-pressure grinding and finishing heat-sensitive alloys
Better	SY603	Narrow, Wide	36-120	Zirconia Alumina	Y-wt. Polyester	BJ	RR	Zirconia alumina abrasive with a Y-wt. polyester backing and a grinding aid for weld removal and finishing of hard-to-grind materials; waterproof
Better	SY695	Narrow, Wide	24-80	Zirconia Alumina	Y-wt. Polyester	BJ	RR	Zirconia alumina grain designed for medium- to high-pressure grinding
Better	SX695	Narrow, Wide	60-220	Zirconia Alumina	X-wt. Polyester	BJ	RR	Zirconia alumina grain on lighter backing designed for light to medium grinding
Good	SY395	Narrow, Wide	24-120	Ceramic-coated Aluminum Oxide	Y-wt. Polyester	BJ	RR	Ceramic-coated aluminum oxide grain provides higher performance than standard aluminum oxide
Good	SX395	Narrow, Wide	P60-P240, P320, P400	Aluminum Oxide	X-wt. Polyester	BJ	RR	Higher-performance P-graded aluminum oxide grain and strong polyester backing for mild steel
Good	MX240	Narrow, Wide	P60-P150	Aluminum Oxide	X-wt. Poly/Cotton	BJ	CF RR	P-graded heat-treated aluminum oxide X-wt. cloth with strong, but flexible, cotton/polyester backing making it an ideal multi-purpose product
Good	KX375	Narrow, Wide	36-240, 320	Aluminum Oxide	X-wt. Cotton	BJ	RR	Initial starting specification for all metalworking applications
Good	KF376	Narrow	P80-P320 P400, P600	Aluminum Oxide	J-wt. Cotton	BJ	TF	P-graded, heat-treated aluminum oxide with ceramic coating on a very flexible backing for use wherever flexibility and conformability are needed

TIER	PRODUCT CAP CODE	SHAPE AVAILABILITY	GRIT SIZE	ABRASIVE GRAIN	BACKING	STANDARD JOINT	STANDARD FLEX	APPLICATIONS
WOODWORKING								
NORTON								
Best	R963	Narrow, Wide	24-60, P80 100-150 coming soon	Norton SG Ceramic Alumina	Y-wt. Polyester	BJ	RR	Norton SG ceramic alumina grain with anti-static coating for forest product applications (MDF, particleboard, plywood)
Best	R955	Narrow	P36-P120	Norton SG Red Heat R955	Y-wt. Cotton	BJ	RR	100% ceramic alumina abrasive with Y-wt. cloth backing for dimensioning, intermediate sanding of wood
Best	H968	Narrow, Wide	P80-P220	Norton SG Ceramic Alumina	F-wt. Paper	CJ	CF	Norton SG ceramic alumina belt for high-performance woodworking applications
Better	R811	Narrow, Wide	24, 36-120	NorZon Zirconia Alumina	Y-wt. Cotton	BJ	RR	NorZon open-coat product recommended for dry low-pressure applications or where loading is a problem
Good	R215	Narrow, Wide	50-180	Aluminum Oxide	X-wt. Cotton	BJ	RR	Initial starting specification for all woodworking applications where loading is a problem
Good	R422	Narrow	50-120	Silicon Carbide	X-wt. Cotton	BJ	RR	Initial starting specification for all woodworking applications where loading is not an issue
Good	R490	Narrow, Wide	P36-P150	Silicon Carbide	Y-wt. Polyester	TP (Top Patch Plyweld)	RR	Anti-static product for forest product applications (MDF, particle board, plywood) where loading is an issue
Better	H275	Narrow, Wide	P100-P220	Aluminum Oxide	F-wt. Paper	CJ	RR	Anti-static wood sanding product where loading is a problem
Good	H448	Narrow, Wide	P80-P220 P280,P320, P400	Silicon Carbide	F-wt. Paper	CJ	RR	Anti-static wood sanding product where loading is a problem



CATEGORY DEFINITION

Flap wheels are an ideal choice for a wide variety of blending, deburring and finishing applications common in the metal fabrication, welding and polishing industries. Flap wheels are conformable to intricate shapes and contours. Designed to deliver a consistent finish with a uniform rate of cut, flap wheels wear away, continually exposing fresh abrasives.

- APPLICATIONS:** Used for a wide range of metal fabrication and welding applications including stock removal, blending, deburring, cleaning, finishing, and polishing
- SIZE RANGE:** Flap Wheels with mounted steel shanks: 3/8" - 3" diameter
 Flap Wheels with mounted 1/4-20 thread: 1" - 3" diameter
 Flap Wheels with arbor holes: 3" - 16" diameter
- GRIT RANGE:** 40 - 320
- ABRASIVE GRAIN:** Ceramic Alumina/Aluminum Oxide, Aluminum Oxide



SHAPE RECOMMENDATION GUIDE

SHAPE

DESCRIPTION/APPLICATION

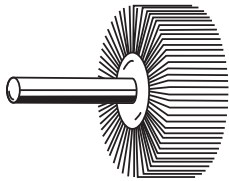

Flap Wheels with Mounted Steel Shanks

Wheels are designed with a 1/8" or 1/4" steel shank as an integral part of each wheel. These shanks run through the wheel creating better balance, a reduction of chatter, and reduced operator fatigue. They also permit quick changes on air tools when using other abrasive products.



Flap Wheels with Mounted 1/4-20 Thread

Wheels are designed with a 1/4"-20 thread and flange as an integral part of the wheel. These threads facilitate the quickest changes on air tools using flap wheels exclusively, as there are no special tools needed to change the flap wheel. Also allow extended reach with accessory mandrels.



Flap Wheels with Arbor Holes

For use on larger portable and fixed-base tools where the wheel must fit on an existing arbor.

APPLICATION/GRIT RECOMMENDATION GUIDE

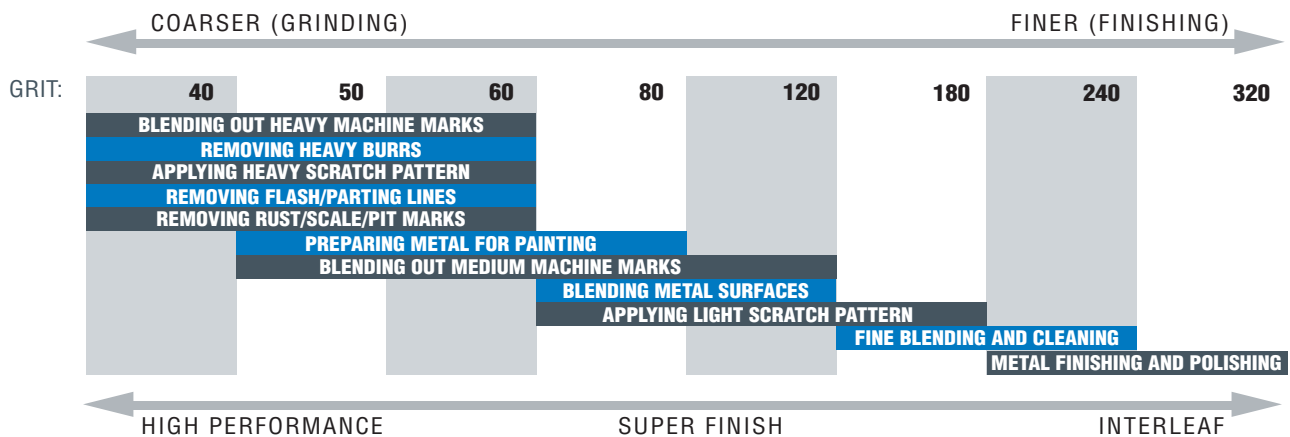

SEE NON-WOVEN FLAP WHEEL SECTION FOR INTERLEAF FLAP WHEELS



FEATURED PRODUCTS



MERIT HIGH PERFORMANCE

BETTER CHOICE FOR MORE DURABLE FLAP WHEEL APPLICATIONS WHERE AGGRESSIVE CUT AND SUPERIOR LIFE ARE REQUIRED

FEATURES

- Long-lasting ceramic alumina/aluminum oxide abrasive grain blend
- Heavy cotton backing

BENEFITS

- Aggressive cut and 2 to 3 times longer life
- Extended durability for added life and reduced edge wear



MERIT SUPER FINISH

BETTER CHOICE WHERE SUPERIOR FINISH IS REQUIRED, OR ON LOW-PRESSURE APPLICATIONS

FEATURES

- Long-lasting premium aluminum oxide blend
- Premium flexible cotton backing

BENEFITS

- Excellent cut rate on low-pressure finishing operations
- Softer acting with more flexibility for improved finishing



MERIT METAL

GOOD CHOICE WHEN INITIAL PRICE IS THE MAIN CONSIDERATION

FEATURES

- Quality aluminum oxide abrasive
- Engineered, low-cost cotton backing
- Competitive initial price point

BENEFITS

- Good cut rate and life
- Longer life and wear resistance
- Best starting specification for end-user unable to measure total performance





Micro-Mini Flap Wheels with 1/8" Mounted Steel Shanks

- The smallest flap wheels, ranging from 3/8" to 1-3/16" diameter, mounted on a 1/8" diameter steel shank
- Provide fast polishing and light deburring of internal workpieces with holes or grooves as small as 1/2"

AVAILABILITY

TIER:	GOOD
BRAND:	Merit
TRADENAME:	MICRO-MINI
ABRASIVE:	Aluminum Oxide

TIER:	GOOD
BRAND:	Merit
TRADENAME:	MICRO-MINI
ABRASIVE:	Aluminum Oxide

D X W X SK.	MAX. RPM	GRIT	STD. PKG.	PART NO.
3/8 x 3/8 x 1/8	40,000	60	10	08834137470
		80		08834137471
		120		08834137472
		180		08834137473
		240		08834137474
		320		08834137475
5/8 x 5/8 x 1/8	37,000	60	10	08834137480
		80		08834137481
		120		08834137482
		180		08834137483
		240		08834137484
		320		08834137485
5/8 x 3/4 x 1/8	37,000	80	10	08834137541
		120		08834137542
		180		08834137543
		240		08834137544
		320		08834137545
		3/4 x 3/16 x 1/8		35,000
80	08834137551			
120	08834137552			
180	08834137553			
240	08834137554			
320	08834137555			
3/4 x 3/8 x 1/8	35,000	60	10	08834137560
		80		08834137561
		120		08834137562
		180		08834137563
		240		08834137564
		320		08834137565
3/4 x 1/2 x 1/8	35,000	60	10	08834137570
		80		08834137571
		120		08834137572
		180		08834137573
		240		08834137574
		320		08834137575

D X W X SK.	MAX. RPM	GRIT	STD. PKG.	PART NO.
3/4 x 5/8 x 1/8	35,000	60	10	08834137580
		80		08834137581
		120		08834137582
		180		08834137583
		240		08834137584
		320		08834137585
3/4 x 3/4 x 1/8	35,000	60	10	08834137590
		80		08834137591
		120		08834137592
		180		08834137593
		240		08834137594
		320		08834137595
1-3/16 x 1/8 x 1/8	30,000	80	10	08834137491
		120		08834137492
		180		08834137493
		240		08834137494
		320		08834137495
		1-3/16 x 3/16 x 1/8		30,000
80	08834137501			
120	08834137502			
180	08834137503			
240	08834137504			
320	08834137505			
1-3/16 x 3/8 x 1/8	30,000	80	10	08834137511
		120		08834137512
		180		08834137513
		240		08834137514
		320		08834137515



Flap Wheel Test Kits

Micro-Mini Test Kit "MMC"

- Part No. 08834131493
- Includes five wheels, 3/8" to 1-3/16" diameter in various grits, mounted on a 1/8" diameter hardened steel shank
- The "MMC" kit is ideal for fast polishing and light deburring of internal holes or grooves as small as 1/2"



Shank-Mounted Mini Test Kit "CMM"

- Part No. 08834138004
- Includes ten wheels, 1" to 3" diameter in various grits mounted on a 1/4" diameter hardened steel shank

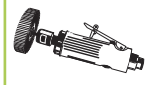

Mini Flap Wheels with 1/4" Mounted Steel Shanks

AVAILABILITY



TIER:	BETTER	BETTER	GOOD	GOOD
BRAND:	Merit	Merit	Norton	Merit
TRADENAME:	HIGH PERFORMANCE	SUPER FINISH	METALITE R265	METAL
ABRASIVE:	Ceramic Alumina/ALO	Aluminum Oxide	Aluminum Oxide	Aluminum Oxide

D X W X SK.	MAX. RPM	GRIT	STD. PKG.	PART NO.	PART NO.	PART NO.	PART NO.
1 x 1/2 x 1/4	30,000	60 80 120	10				08834149800 08834149801 08834149802
1 x 5/8 x 1/4	30,000	40 60 80 120 180 240 320	10	08834137105 08834137100 08834137101 08834137102 08834131536 08834137104 08834137357	08834130754 08834130755 08834130756 08834130757 08834130758 08834130759	63642502576 63642502577 63642502578	
1 x 1 x 1/4	30,000	40 50 60 80 120 180 240 320	10	08834131259 08834137309 08834137310 08834137311 08834137312 08834137313 08834137114 08834137315	08834130760 08834130761 08834130762 08834130763 08834130764 08834130765	63642502580 63642502581 63642502582 63642502583	08834149803 08834149804 08834149805 08834149806 08834149807 08834149808 08834149809
1-3/16 x 1/4 x 1/4	25,000	60 80 120	10		08834137600 08834137601 08834137602		
1-3/16 x 1/2 x 1/4	25,000	60 80 120	10		08834137810 08834137811 08834137812		
1-3/8 x 5/8 x 1/4	30,000	60 80 120 180 240	10	08834137320 08834137321 08834137322 08834137323 08834137324		63642502584 63642502585	
1-1/2 x 1/2 x 1/4	25,000	60 80 120 180 240	10		08834137130 08834137131 08834137132 08834137133 08834137134		08834149810 08834149811 08834149812
1-1/2 x 1 x 1/4	25,000	40 60 80 120 180 240 320	10	08834135140 08834137340 08834137141 08834137142 08834137343 08834132101 08834137145	08834130766 08834130767 08834130768 08834130769 08834130770 08834130771	63642502592 63642502593 63642502594	08834149816 08834149817 08834149818 08834149819
1-1/2 x 1-1/2 x 1/4	25,000	40 60 80 120 180	10	08834130642 08834130643 08834130644 08834130641 08834130695			
2 x 1/2 x 1/4	25,000	40 60 80 120 180 240 320	10		08834137350 08834137151 08834137152 08834137353 08834137354 08834137355	63642502596 63642502597	08834149820 08834149821 08834149822 08834149823

CONTINUED



Mini Flap Wheels with 1/4" Mounted Steel Shanks CONTINUED

AVAILABILITY

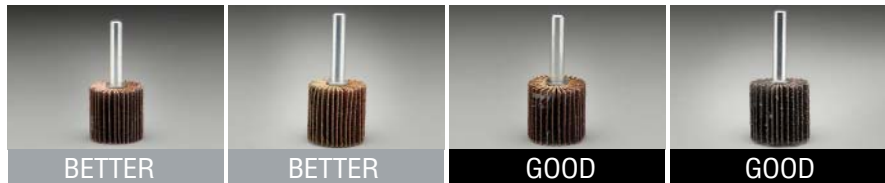

TIER:

BRAND:

TRADENAME:

ABRASIVE:

D X W X SK.	MAX. RPM	GRIT	STD. PKG.	HIGH PERFORMANCE		SUPER FINISH		METALITE R265		METAL	
				Ceramic Alumina/ALO	Aluminum Oxide	Aluminum Oxide	Aluminum Oxide	Aluminum Oxide	Aluminum Oxide		
				PART NO.	PART NO.	PART NO.	PART NO.	PART NO.	PART NO.	PART NO.	PART NO.
2 x 3/4 x 1/4	25,000	40	10	08834137158							
		60		08834137160		08834130772					
		80		08834137161		08834130773					
		120		08834137162		08834130774					
		180		08834137163		08834130775					
2 x 1 x 1/4	25,000	40	10	08834137377						08834149824	
		50		08834137169							
		60		08834137370		08834130778		63642502600		08834149825	
		80		08834137371		08834130779		63642502601		08834149826	
		120		08834137372		08834130780		63642502602		08834149827	
		180		08834137373		08834130781		63642502603		08834149828	
		240		08834137374		08834130782					
320	08834137375		08834130783								
2 x 1-1/2 x 1/4	25,000	40	10	08834137183							
		60		08834137380		08834130784					
		80		08834137381		08834130785					
		120		08834137382		08834130786					
		240		08834137384							
320	08834137319										
2-1/2 x 1/2 x 1/4	20,000	60	10					63642502604			
		80					63642502605				
		120					63642502606				
2-1/2 x 1 x 1/4	20,000	40	10	08834137408							
		60		08834137410		08834130790		63642502608			
		80		08834137411		08834130791		63642502609			
		120		08834137412		08834130792		63642502610			
		180		08834137413		08834130793					
		240		08834137633		08834130794					
320	08834137415		08834130795								
2-1/2 x 1-1/2 x 1/4	20,000	60	10	08834137420							
		80		08834137421							
		120		08834137422							
3 x 1/2 x 1/4	20,000	40	10							08834149833	
		60				08834137230		63642502612		08834149834	
		80				08834137231		63642502613		08834149835	
		120				08834137232		63642502614			
		180				08834137433					
		240				08834137235					
320			08834137287								
3 x 3/4 x 1/4	20,000	60	10	08834137440		08834130796					
		80		08834137441		08834130797					
		120				08834130798					
3 x 1 x 1/4	20,000	40	10	08834137456						08834149836	
		60		08834137450		08834130802		63642502620		08834149837	
		80		08834137451		08834130803		63642502621		08834149838	
		120		08834137252		08834130804		63642502622		08834149839	
		180		08834137253		08834130805		63642502623		08834149840	
		240		08834135339		08834130806					
		320		08834135341		08834130807					
3 x 2 x 1/4	12,000	40	10	08834137460							
		60		08834137260							
		80		08834137261							
		120		08834137262							
		180		08834137263							



Mini Flap Wheels with 1/4"-20 Thread

AVAILABILITY



TIER:

BRAND:

TRADENAME:

ABRASIVE:

	BETTER	BETTER	GOOD
	Merit	Merit	Norton
	HIGH PERFORMANCE	SUPER FINISH	METALITE R265
	Ceramic Alumina/Aluminum Oxide	Aluminum Oxide	Aluminum Oxide

D X W X THD.	MAX. RPM	GRIT	STD. PKG.	PART NO.	PART NO.	PART NO.		
1 x 5/8 x 1/4-20	30,000	60	10	08834131001	08834130700	63642502624		
		80		08834131002			08834130701	63642502625
		120		08834131003			08834130702	63642502626
		180					08834130703	
1 x 1 x 1/4-20	30,000	40	10	08834131027	08834130706	63642502628		
		60		08834131008			08834130707	63642502629
		80		08834131009			08834130708	63642502630
		120		08834131010			08834130709	63642502631
		180		08834131011			08834130710	
		240		08834131012			08834130711	
		320		08834131013				
1-3/8 x 5/8 x 1/4-20	30,000	60	10	08834132001	08834130834	63642502632		
		80		08834132002			63642502633	
		120		08834132003			63642502634	
1-5/8 x 1/2 x 1/4-20	25,000	60	10		08834132008			
		80		08834132009				
		120		08834132010				
		180		08834132011				
1-5/8 x 1 x 1/4-20	25,000	40	10	08834132051	08834130712	63642502638		
		60		08834132015			08834130713	63642502639
		80		08834132016			08834130714	63642502640
		120		08834132017			08834130715	
		180		08834132018				
		320		08834132020				
2 x 1/2 x 1/4-20	25,000	60	10		08834133001	63642502642		
		80		08834133002			63642502643	
		120		08834133003			63642502644	
		180		08834133004				
		320		08834133006				
2 x 3/4 x 1/4-20	25,000	60	10	08834133008	08834130718			
		80		08834133009			08834130719	
		120		08834133010			08834130720	
		180		08834133011				
2 x 1 x 1/4-20	25,000	40	10	08834133044	08834130724	63642502646		
		60		08834133015			08834130725	63642502647
		80		08834133016			08834130726	63642502648
		120		08834133017			08834130727	63642502649
		180		08834133018			08834130728	
		240		08834133019			08834130729	
		320		08834133020				
2 x 1-1/2 x 1/4-20	25,000	60	10	08834135201	08834130730			
		80		08834135202			08834130731	
		120		08834135203			08834130732	
		180		08834135204				
2-1/2 x 1/4 x 1/4-20	20,000	60	10		08834134001			
		80		08834134002				
		120		08834134003				
		180		08834134004				
2-1/2 x 3/8 x 1/4-20	20,000	60	10		08834134008			
		80		08834134009				
		120		08834134010				
2-1/2 x 1/2 x 1/4-20	20,000	60	10		08834134015	63642502650		
		80		08834134016			63642502651	
		120		08834134017				
		180		08834134018				
2-1/2 x 1 x 1/4-20	20,000	40	10	08834134061	08834130736	63642502654		
		60		08834134022			08834130737	63642502655
		80		08834134023			08834130738	63642502656
		120		08834134024				
		180		08834134025				

FOR ADAPTERS FOR FLAP WHEELS WITH 1/4"-20 THREAD, SEE THE END OF THIS SECTION



Mini Flap Wheels with 1/4"-20 Thread CONTINUED

AVAILABILITY

D X W X THD.	MAX. RPM	GRIT	STD. PKG.	TIER: BETTER		
				BRAND: Merit		
TRADENAME: HIGH PERFORMANCE				BRAND: Merit		
ABRASIVE: Ceramic Alumina/Aluminum Oxide				ABRASIVE: Aluminum Oxide		
				TIER: GOOD		
				BRAND: Norton		
				TRADENAME: METALITE R265		
				ABRASIVE: Aluminum Oxide		
				PART NO.		
3 x 1/2 x 1/4-20	20,000	60	10			
3 x 3/4 x 1/4-20	20,000	60	10	08834135001	08834135001	63642502659
				08834135002	08834135002	63642502660
				08834135003	08834135003	
				08834135004	08834135004	
3 x 1 x 1/4-20	20,000	40	10			

FOR ADAPTERS FOR FLAP WHEELS WITH 1/4-20 THREAD, SEE THE END OF THIS SECTION



Cup-Type Mini Flap Wheels with 1/4" Mounted Steel Shanks

- Primarily used for bottom or side-wall type sanding where conventional tools do not reach
- Cup-type mini flap wheels will not mar your workpiece while reaching flush into areas where other wheels cannot

D X W X SK.	MAX. RPM	GRIT	STD. PKG.	TIER: GOOD	
				BRAND: Merit	
ABRASIVE: Aluminum Oxide				PART NO.	
2-1/2 x 1-1/2 x 1/4	20,000	60	10	08834144463	

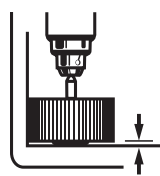

TYPICAL WHEELS

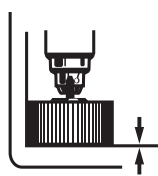

CUP WHEELS GET FLUSH INTO CORNERS AND THE BOTTOMS OF CYLINDERS

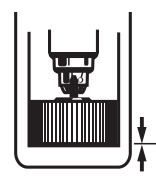

Flap Wheel Test Kits

Mini 1/4"-20 Thread Test Kit "CQ"

- Part No. 08834138001
- Includes ten, 1" to 3" diameter, 1/4"-20 thread mini flap wheels
- Each kit includes a 1/4"-20 QC-4 quick-change adapter



3-1/2" – 8" Flap Wheels with Arbor Holes

AVAILABILITY



TIER:

BRAND:

TRADENAME:

ABRASIVE:

BETTER

GOOD

Merit

Norton

HIGH PERFORMANCE

METALITE R265

Ceramic Alumina/Aluminum Oxide

Aluminum Oxide

<i>D X W X H</i>	<i>MAX. RPM</i>	<i>GRIT</i>	<i>STD. PKG.</i>	<i>PART NO.</i>	<i>PART NO.</i>
3-1/2 x 1 x 5/8	12,000	40	10	08834122001	63642502668 63642502669
		50		08834122002	
		60		08834122003	
		80		08834122004	
		120		08834122006	
		180		08834122007	
		240		08834122008	
		320		08834122009	
		3-1/2 x 1-1/2 x 5/8		12,000	
50	08834122012				
60	08834122013				
80	08834122014				
120	08834122016				
150	08834122017				
180	08834122018				
240	08834122019				
320	08834122020				
3-1/2 x 2 x 5/8	12,000	40	10	08834122022	
		60		08834122024	
		80		08834122025	
		120		08834122027	
		180		08834122028	
4' x 1 x 5/8	12,000	40	10	08834122032	63642502673 63642502674 63642502675
		50		08834122033	
		60		08834122034	
		80		08834122035	
		120		08834122037	
		180		08834122038	
		240		08834122039	
		320		08834122040	
4 x 1-1/2 x 5/8	12,000	40	10	08834122042	
		50		08834122043	
		60		08834122044	
		80		08834122045	
		120		08834122047	
		240		08834122050	
4 x 2 x 5/8	12,000	40	10	08834122053	63642502677
		50		08834122054	
		60		08834122055	
		80		08834122056	
		120		08834122058	
		180		08834122059	
		240		08834122060	
		320		08834122061	
5 x 1 x 5/8	6,200	80	5		63642502678
5 x 1-1/2 x 5/8	12,000	40	10	08834122063	
		50		08834122064	
		60		08834122065	
		80		08834122066	
		120		08834122068	
		180		08834122070	
		240		08834122071	
		320		08834122072	
6 x 1/2 x 1	6,000	40	10	08834123001	
		60		08834123003	
		80		08834123004	
		120		08834123005	
		150		08834122198	
		180		08834123006	
		240		08834123007	
		320		08834122137	

FOR FLAP WHEEL WITH ARBOR HOLE ADAPTERS AND BUSHINGS, SEE THE END OF THIS SECTION

CONTINUED



3-1/2" – 8" Flap Wheels with Arbor Holes CONTINUED

AVAILABILITY



TIER:

BRAND:

TRADENAME:

ABRASIVE:

BETTER

BETTER

GOOD

GOOD

Merit

Merit

Norton

Merit

HIGH PERFORMANCE

SUPER FINISH

METALITE R265

METAL

Ceramic Alumina/ALO

Aluminum Oxide

Aluminum Oxide

Aluminum Oxide

<i>D X W X H</i>	<i>MAX. RPM</i>	<i>GRIT</i>	<i>STD. PKG.</i>	<i>PART NO.</i>	<i>PART NO.</i>	<i>PART NO.</i>	<i>PART NO.</i>				
6 x 1 x 1	6,000	40	5	08834123009		63642502679	08834120167				
				08834123010			08834120168				
				08834123011	08834121002	63642502680	08834120169				
				08834123012	08834121003	63642502681	08834120170				
							08834120171				
				08834123014	08834121005	63642502682	08834120172				
				08834123015	08834121006						
				08834123016	08834121007		08834120174				
				08834123017	08834121008		08834120176				
				08834123018	08834121009		08834120177				
				6 x 1-1/2 x 1	6,000	40	5	08834123020			
08834123021											
08834123022	08834121023	63642502686									
08834123023	08834121024	63642502687									
08834123025	08834121025										
08834123026	08834121106										
08834123027	08834121026										
08834123028	08834121027										
08834123029	08834121109										
6 x 2 x 1	6,000	40	5					08834123031		63642502689	08834120189
								08834123032			08834120190
				08834123033	08834121030	63642502691	08834120191				
				08834123034	08834121031	63642502692	08834120192				
							08834120198				
				08834123036	08834121032	63642502694	08834120194				
				08834123038	08834121033		08834120197				
				08834123039	08834121034		08834120199				
				08834123040	08834121035		08834120493				
				6 x 3 x 1	6,000	40	3	08834123053			
08834123054											
08834123055		63642502696									
08834123056											
08834123058											
08834122544											
08834123060											
08834123061											
08834122329											
8 x 1 x 1	4,500	40	3					08834123070			
								08834123071			
				08834123072		63642502698					
				08834123073							
				08834123075							
				08834123077							
				08834123078							
				08834123079							
				8 x 2 x 1	4,500	40	3	08834123092			
								08834123093			
								08834123094		63642502700	
08834123095		63642502701									
08834123097											
08834123099											
08834123100											
08834123101											

FOR FLAP WHEEL WITH ARBOR HOLE ADAPTERS AND BUSHINGS, SEE THE END OF THIS SECTION



10" – 16" Large Flap Wheels with Arbor Holes

Wide range of applications:

- For polishing/grinding jobs in production work as well as clean-up and maintenance jobs
- Work on metals, plastic, rubber and wood

Easy to operate:

- No adjustments, dressing, or preparation required before or during operation

Fewer rejected parts:

- More forgiving than other abrasive products
- Reduce the possibility of flattening, gouging and surface deformation

AVAILABILITY

					TIER: BETTER
					BRAND: Merit
					TRADENAME: HIGH PERFORMANCE
					ABRASIVE: Ceramic Alumina/ALO
<i>D X W X H</i>	<i>MAX. RPM</i>	<i>GRIT</i>	<i>STD. PKG.</i>	<i>PART NO.</i>	
10 x 1 x 1-3/4	4,000	40	4	08834122223	
		60		08834124002	
		80		08834124003	
		120		08834124005	
		150		08834124006	
		180		08834124007	
		240		08834122889	
10 x 1-1/2 x 1-3/4	4,000	60	4	08834124022	
		80		08834124023	
		120		08834124025	
		180		08834124027	
10 x 2 x 1-3/4	4,000	60	2	08834124042	
		80		08834124043	
		120		08834124045	
		180		08834124047	
10 x 3 x 1-3/4	4,000	60	2	08834124077	
		80		08834122316	
		120		08834122131	
		180		08834122132	
12 x 1 x 1-3/4	3,000	60	4	08834124085	
		80		08834122349	
		120		08834122311	
		180		08834122315	
12 x 2 x 1-3/4	3,000	40	2	08834122248	
		50		08834122249	
		60		08834122250	
		80		08834122267	
		120		08834122269	
		150		08834122270	
		180		08834122271	
		240		08834122273	
320	08834122275				
12 x 4 x 1-3/4	2,400	50	1	08834120013	
		60		08834120014	
		80		08834120015	
		120		08834120016	
		180		08834120017	
		240		08834120019	
14 x 1 x 1-3/4	2,400	60	1	08834120020	
		80		08834120021	
		120		08834120022	
		180		08834120023	
14 x 1-1/2 x 1-3/4	2,400	60	1	08834120024	
		80		08834120025	
		120		08834120026	
		180		08834120027	
14 x 2 x 1-3/4	2,400	60	1	08834120028	
		80		08834123215	
		120		08834122907	
		240		08834120032	

AVAILABILITY

					TIER: BETTER
					BRAND: Merit
					TRADENAME: HIGH PERFORMANCE
					ABRASIVE: Ceramic Alumina/ALO
<i>D X W X H</i>	<i>MAX. RPM</i>	<i>GRIT</i>	<i>STD. PKG.</i>	<i>PART NO.</i>	
14 x 3 x 1-3/4	2,400	60	1	08834120033	
		80		08834120034	
		120		08834120035	
		240		08834120036	
14 x 4 x 1-3/4	2,000	60	1	08834120037	
		80		08834122829	
		120		08834122502	
		180		08834120040	
240	08834120041				
16 x 1 x 1-3/4	2,400	60	1	08834120042	
		80		08834120043	
		120		08834120044	
		180		08834120045	
240	08834120046				
16 x 2 x 1-3/4	2,400	60	1	08834120047	
		80		08834120049	
		120		08834120050	
		180		08834120051	
240	08834120052				
16 x 3 x 1-3/4	2,400	60	1	08834120053	
		80		08834120054	
		120		08834120055	
		180		08834120056	
		240		08834120057	
16 x 4 x 1-3/4	2,000	60	1	08834120058	
		80		08834120059	
		120		08834120060	
		180		08834120061	
		240		08834122435	
16 x 5 x 1-3/4	2,000	60	1	08834120063	
		80		08834120064	
		180		08834120065	
		240		08834120066	
16 x 6 x 1-3/4	2,000	60	1	08834120067	
		80		08834120068	
		120		08834120069	
		180		08834120070	
		240		08834120071	
16 x 8 x 1-3/4	1,800	60	1	08834120072	
		80		08834120073	
		120		08834120074	
		180		08834120075	
240	08834120076				
16 x 10 x 1-3/4	1,800	60	1	08834120077	
		80		08834120078	
		120		08834120079	
		180		08834120080	
240	08834120081				

FOR FLAP WHEEL WITH ARBOR HOLE ADAPTERS AND BUSHINGS, SEE THE END OF THIS SECTION

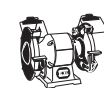

Adapter and Bushings for Flap Wheels with Arbor Holes

WHEEL DIAMETER	ADAPTERS	PART NO.
SHANK ADAPTERS		
3-1/2	1/4 Shank	08834125001
3-1/2	3/8 Shank	08834125007
4 - 8	1/4 Shank	08834125003
THREADED MOUNTING ADAPTERS		
4 - 8	3/8-24 Thread	08834125009
4 - 8	5/8-11 Thread	08834125027
REDUCING BUSHINGS		
6 - 8	1 to 3/8	08834125016
	1 to 1/2	08834125017
	1 to 5/8	08834125018
	1 to 3/4	08834125019
	1 to 7/8	08834125020

STANDARD PACKAGES = 1 ADAPTER, 1 PAIR OF BUSHINGS



08834125001



08834125007



08834125003



08834125009



08834125027



08834125016

Adapters for 1/4"-20 Thread Mini and Arbor Hole Flap Wheels

MODEL	DESCRIPTION	PART NO.
ADAPTERS		
ADAPT C	Fits 3 x 2 x 3/8 arbor flap wheel	08834137009
MA-100	Fits A.H. Mini Wheel	08834137007
QC-8	1/8 x 5/8	08834137002
QC-4	1/4 SK. Dia. x 5/8 SK. L.	08834137001
QC-44	1/4 x 4	08834137003
QC-46	1/4 x 6	08834137004
QC-48	1/4 x 8	08834137005
QC-T	1/4-20 Thread	08834137012
QC-T	3/8-24 Thread	08834137010

STANDARD PACKAGE = 1 ADAPTER
OTHER THREAD SIZES AVAILABLE FOR QUOTATION



QC-4

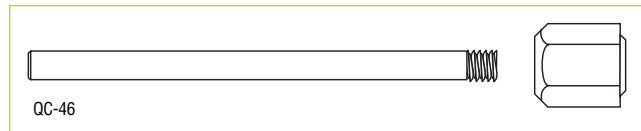

QC-46



QC-T



Sand-O-Flex Wheels

With their firm cushioning brushes, Sand-O-Flex's abrasive strips are forced into, around and over corners, hollow and fluted surfaces, and small openings. Pressure is distributed evenly over the surface to prevent loss of detail and the flattening of rounded areas; for sanding metals, woods, plastics, rubber and ceramic.

Sand-O-Flex wheels are designed to fit most standard equipment. They load quickly and easily by turning the index knob as needed, allowing you to change grit size in minutes. Sand-O-Flex refills are available both scored (for finer, less aggressive work) and unscored. And, with the use of Merit adapters, Sand-O-Flex wheels will fit most electric bench grinders.



Sand-O-Flex Wheels – Model 350-RP

- Diameter: 6-1/2" overall, 4" diameter high-impact plastic body
- 1" wide abrasive strips backed by 8 cushioning brushes
- 1/4" diameter steel shank
- Weight: 9-1/2 oz.
- Maximum operating speed: 2,400 RPM
- Special adapter required for bench grinder use
- Some assembly required



AVAILABILITY

TIER:	GOOD
BRAND:	Merit
TRADENAME:	SAND-O-FLEX
ABRASIVE:	Aluminum Oxide

MODEL NO.	GRIT	PART NO.
SAND-O-FLEX WHEEL		
350-RP		08834111051
COMES ASSEMBLED WITH 80 GRIT A/O RESIN BOND SCORED REFILL AND BRUSHES		
SAND-O-FLEX ACCESSORIES		
Bench Grinder Adapter 350-RP		08834111055
1/4 Shank to 1/2 Shank		
Replacement Brushes for 350-RP; 8 per set		08834113003
RESIN BOND REFILLS		
350-RP SCORED	60	08834111052
10/box	80	08834111053
	100	08834112114
	120	08834111054
	180	08834111057
350-RP UNSCORED	60	08834112031
10/box	80	08834111059
	100	08834112021
	120	08834112032
	180	08834112033
GLUE BOND REFILLS		
350-RP SCORED	60	08834112053
10/box	80	08834112054
	100	08834112055
	120	08834112056
	150	08834112057
	180	08834112058
	240	08834112059
	320	08834112060
350-RP UNSCORED	60	08834112043
10/box	80	08834112044
	100	08834112045
	120	08834112046
	150	08834112047
	180	08834112048
	240	08834112049
	320	08834112050



CATEGORY DEFINITION

Best product for blending and polishing contours when smooth running is a primary concern. Used for finishing hard-to-reach areas, removing parting lines, imperfections, and burrs on all surfaces.

- BENEFITS:**
- Spiral construction avoids shadow marks and provides smooth, chatter-free cutting action
 - Achieves close tolerances when finishing curved, contoured, and hard-to-reach areas
 - Fast cutting and removes toughest metal
 - Bands are easily removed and replaced
- GRIT RANGE:** 24 - 320
- ABRASIVE GRAIN:** Aluminum Oxide
- OTHER:** Use with rubber expanding drum

APPLICATION/GRIT RECOMMENDATION GUIDE

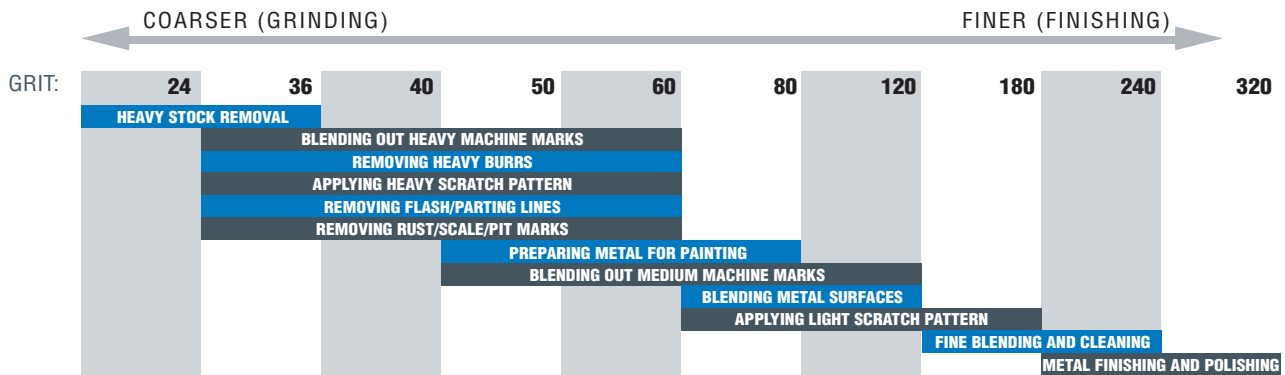



AVAILABILITY

GRIT	TIER: GOOD						
	1/4 X 1/2	1/4 X 1	3/8 X 1/2	3/8 X 1	1/2 X 1/2	1/2 X 1	1/2 X 1-1/2
24	-	-	-	-	08834196732	08834196712	-
36	-	-	-	08834197674	08834196619	08834196591	08834196237
40	08834196614	-	-	-	08834196234	08834196174	-
50	08834196292	08834196785	08834196386	-	08834196228	08834196214	08834197111
60	08834196342	08834196886	08834196829	08834196999	08834196068	08834196212	08834196053
80	08834196269	08834196733	08834196512	08834196645	08834196179	08834196215	08834196646
100	08834196511	08834196734	08834196513	-	08834196189	08834196534	08834196540
120	08834196217	08834197004	08834196747	08834196218	08834196069	08834196210	08834196324
150	08834196327	-	-	-	08834196211	08834196772	-
180	08834196490	-	08834196504	-	08834196209	08834196713	-
240	-	-	08834196481	-	08834196564	08834196814	-
320	08834196865	-	08834196830	-	08834196505	08834196487	-
PKG. QTY. STOCK	100/box	100/box	100/box	100/box	100/box	100/box	100/box
MOQ NON-STOCK	400	400	300	300	300	300	300
EXPANDING RUBBER DRUMS							
	1/8 Shank 30,000 RPM 08834196030	1/8 Shank 30,000 RPM 08834196008	1/8 Shank 30,000 RPM 08834196944	1/8 Shank 18,000 RPM 08834196011	1/4 Shank 30,000 RPM 08834196904	1/4 Shank 15,000 RPM 08834196906	1/4 Shank 12,000 RPM 08834196907



AVAILABILITY

TIER:		GOOD					
GRIT	1/2 X 2	3/4 X 1/2	3/4 X 3/4	3/4 X 1	3/4 X 1-1/2	3/4 X 2	1 X 1/2
24	08834197217	08834196345	08834196613	08834196776	08834196596	-	-
36	08834196758	08834196769	08834196609	08834196261	08834196238	08834196953	08834196058
40	08834196825	08834196605	08834196236	08834196517	08834196227	08834196826	-
50	08834196548	08834196608	08834196183	08834196515	08834196500	08834196757	-
60	08834196549	08834196578	08834196168	08834196070	08834196554	08834196745	08834196580
80	08834196669	08834196255	08834196161	08834196071	08834196249	08834196756	08834196647
100	08834196735	08834196567	08834196230	08834196502	08834196501	08834196766	08834196157
120	08834196736	08834196579	08834196226	08834196219	08834196057	08834196746	08834197592
150	-	08834196631	08834196231	08834196822	08834196606	08834197283	-
180	-	08834197116	08834196056	08834196565	08834196851	-	08834196395
240	-	08834196603	08834196859	08834196668	-	66254410751	08834197287
320	-	08834196806	-	08834196624	08834199664	-	-
PKG. QTY. STOCK	100/box	100/box	100/box	100/box	100/box	100/box	100/box
MOQ NON-STOCK	200	300	300	300	300	200	200
EXPANDING RUBBER DRUMS							
	1/4 Shank 10,000 RPM 08834196908	1/4 Shank 27,000 RPM 08834196909	1/4 Shank 24,000 RPM 08834196910	1/4 Shank 17,000 RPM 08834196911	1/4 Shank 10,000 RPM 08834196912	1/4 Shank 10,000 RPM 08834196913	1/4 Shank 20,000 RPM 08834196914

TIER:		GOOD					
GRIT	1 X 1	1 X 1-1/2	1 X 2	1-1/2 X 1	1-1/2 X 1-1/2	1-1/2 X 2	2 X 1
24	08834196563	08834196708	08834196709	08834196684	08834196220	08834196539	08834196841
36	08834196072	08834196525	08834196267	08834196222	08834196164	08834196657	08834196233
40	08834196073	08834196546	08834196689	08834196223	08834196171	08834196598	08834196109
50	08834196184	08834196078	08834196588	08834196185	08834196176	08834196252	08834196186
60	08834196075	08834196060	08834196506	08834196503	08834196091	08834196067	08834196232
80	08834196074	08834196162	08834196268	08834196254	08834196165	08834196533	08834196166
100	08834196167	08834196257	08834196750	08834196216	08834196182	08834196543	08834196508
120	08834196177	08834196677	08834196507	08834196707	08834196066	08834196079	08834196595
150	08834196686	08834197639	08834197664	08834196989	08834197750	08834197376	-
180	08834196059	08834196790	08834196987	-	08834196535	-	08834197983
240	08834196178	08834196526	08834197254	08834196491	08834196260	08834197709	-
320	08834196789	08834197700	-	08834196063	08834197647	-	-
PKG. QTY. STOCK	100/box	100/box	100/box	100/box	100/box	100/box	100/box
MOQ NON-STOCK	300	200	200	300	200	200	200
EXPANDING RUBBER DRUMS							
	1/4 Shank 18,000 RPM 08834196916	1/4 Shank 10,000 RPM 08834196917	1/4 Shank 8,000 RPM 08834196918	1/4 Shank 12,000 RPM 08834196921	1/4 Shank 10,000 RPM 08834196922	1/4 Shank 8,000 RPM 08834196923	1/4 Shank 11,000 RPM 08834196926

TIER:		GOOD				
GRIT	2 X 1-1/2	2 X 2	3 X 1	3 X 2	3 X 3	
24	08834196700	08834196516	08834196795	08834196263	08834196256	
36	08834196509	08834196110	08834196717	08834196545	08834196262	
40	08834196514	08834196172	08834196755	08834196090	08834196555	
50	08834196527	08834196187	08834196666	08834196264	08834196253	
60	08834196978	08834196173	08834196150	08834196530	08834196188	
80	08834196259	08834196181	08834196524	08834196265	08834196159	
100	08834196521	08834196193	08834196831	-	08834196250	
120	08834196586	08834196585	08834196089	08834196531	08834196572	
150	-	08834196629	-	-	08834196452	
180	08834196536	08834196306	-	08834196472	08834196131	
240	-	08834196375	-	-	08834196574	
320	-	08834196628	-	-	08834197968	
PKG. QTY. STOCK	100/box	100/box	100/box	100/box	100/box	
MOQ NON-STOCK	200	200	200	100	100	
EXPANDING RUBBER DRUMS						
	1/4 Shank 8,000 RPM 08834196927	1/4 Shank 6,000 RPM 08834196928	3/8 Shank 3,000 RPM 08834196929	3/8 Shank 3,000 RPM 08834196930	3/8 Shank 3,000 RPM 08834196931	

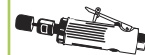

CATEGORY DEFINITION

Cartridge, spiral rolls and cone points are strips of abrasive cloth rolled and glued to form a solid shape that is designed to break down during use and reveal the next layer of abrasive.

APPLICATIONS:	Used on inside surfaces and inside corners where other forms of abrasive cannot reach. Typically these are used on high speed air grinders and are always mounted on a mandrel. Ideal for flash removal, polishing, or removing machine tool marks, and edge breaking.
SHAPES:	Cartridge Rolls, Spiral Rolls (Full Taper, Half Taper, and Sidewall Taper), Tapered Cone Points
GRIT RANGE:	36 – 320
ABRASIVE GRAIN:	Ceramic Alumina, Aluminum Oxide, Silicon Carbide
BACKING:	Cotton Cloth
MAXIMUM RPM:	1/8" to 1/2" – 23,000 5/8" to 1" – 18,000 1" to 1-1/2" – 15,000

APPLICATION/GRIT RECOMMENDATION GUIDE

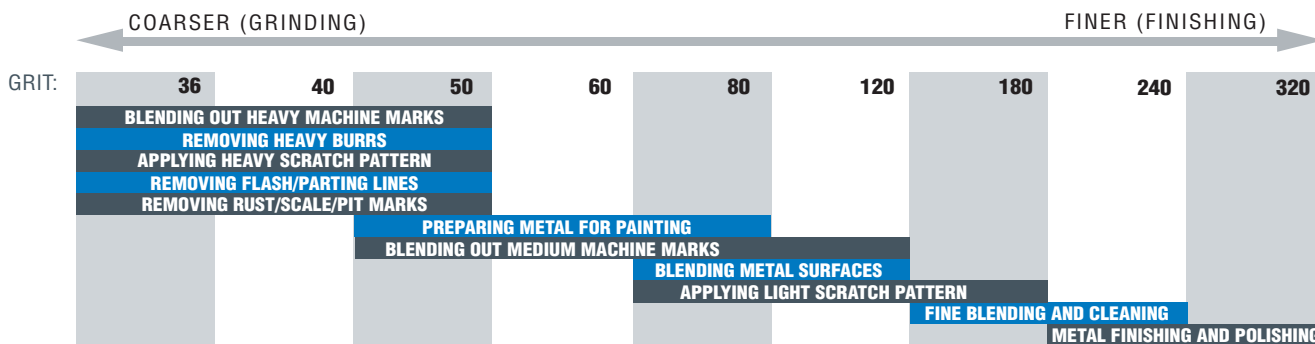

FEATURED PRODUCTS



MERIT BLAZE

FOR HARD-TO-GRIND MATERIALS – STAINLESS STEEL, COBALT, INCONEL, AND TITANIUM

FEATURES

- Next-generation ceramic alumina abrasive grain
- Advanced grinding aid
- Improved resin bond system

BENEFITS

- Significantly faster cut rates
- Resists wear, resulting in 50% – 300% longer life
- Greatest productivity
- Cooler cutting, longer life
- Exceptional grain retention and longer life

Refer to the back of this section for mandrels.



Cartridge Rolls

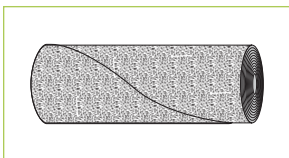

- Effective for flash removal
- Polishing or removing machine tool marks
- Edge Breaking
- Valuable abrasive tool for reaching into corners, where larger diameter tools cannot work
- All cartridge roll part numbers shown are resin bond, half-glued
- Quarter and full glue are also available for quotation

FEATURED PRODUCTS



Merit Blaze Cartridge Rolls

- With their exclusive ceramic grain technology, grinding aid, and X-weight cotton backing, Merit Blaze products outperform all competitive ceramic, zirconia, and aluminum oxide specialty products in today's markets
- Merit Blaze specialties cut cooler and last longer on stainless steel, cobalt, Inconel, titanium and other hard-to-grind materials

AVAILABILITY

TIER: **BEST**
 ABRASIVE: Ceramic Alumina
 BACKING: Cotton
 OTHER: Supersized

D X L X H	GRIT	STD. PKG.	PART NO.
1/4 x 1-1/2 x 1/8 Use M-9 Mandrel	60	100	66261194384
	80		66261194394
	120		66261194397
3/8 x 1-1/2 x 1/8 Use M-9 Mandrel	60	100	66261194392
	80		66261194395
	120		66261194398
1/2 x 1-1/2 x 1/8 Use M-9 Mandrel	60	100	66261194393
	80		66261194396
	120		66261194399



Merit Silicon Carbide Cartridge Rolls

- Sharp silicon carbide grain penetrates tough, difficult-to-grind materials, as well as soft, loading materials:
 - titanium
 - masonry
 - composites
 - plastic
 - rubber

AVAILABILITY

TIER: **GOOD**
 ABRASIVE: Silicon Carbide
 BACKING: Cotton

D X L X H	GRIT	STD. PKG.	PART NO.
1/4 x 1-1/2 x 1/8 Use M-9 Mandrel	60	100	08834183274
	80		08834182359
	120		08834189131
3/8 x 1-1/2 x 1/8 Use M-9 Mandrel	60	100	08834181309
	80		08834180710
	120		66261042229
1/2 x 1-1/2 x 1/8 Use M-9 Mandrel	60	100	08834189233
	80		08834180712
	120		66261086969



Merit Aluminum Oxide Cartridge Rolls

- Most effective starting specification for flash removal, polishing or removing machine tool marks and edge breaking on all types of metal

AVAILABILITY

TIER: **GOOD**
 ABRASIVE: Aluminum Oxide
 BACKING: Cotton

D X L X H	GRIT	STD. PKG.	PART NO.
1/4 x 3/4 x 1/8 Use M-3 or M-7 Mandrel	60	100	08834180042
	80		08834180043
	120		08834180045
1/4 x 1 x 1/8 Use M-4 or M-8 Mandrel	50	100	08834180060
	60		08834180061
	80		08834180062
	100		08834180063
	120		08834180064
	150		08834180065
	180		08834180066
240	08834180068		
320	08834180070		
1/4 x 1-1/2 x 1/8 Use M-9 Mandrel	50	100	08834180079
	60		08834180080
	80		08834180081
	100		08834180082
	120		08834180083
1/4 x 2 x 1/8 Use M-10 Mandrel	150	100	08834180084
	180		08834180085
	240		08834180089
	320		08834180100
	100		08834180101
120	08834180102		

TIER: **GOOD**
 ABRASIVE: Aluminum Oxide
 BACKING: Cotton Cloth

DIA. X L. X A.H.	GRIT	STD. PKG.	PART NO.
3/16 x 3/4 x 3/32	80	100	08834180005
3/16 x 1 x 3/32 Use M-2E Mandrel	60	100	08834180023
	80		08834180024
	100		08834180025
	120		08834180026
	150		08834180027
	180		08834180028
	240		08834180030
	320		08834180032

Refer to the back of this section for mandrels.

CONTINUED

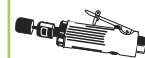

Merit Aluminum Oxide Cartridge Rolls CONTINUED

<i>D X L X H</i>	<i>GRIT</i>	<i>STD. PKG.</i>	TIER: GOOD
			ABRASIVE: Aluminum Oxide
			BACKING: Cotton
<i>PART NO.</i>			
5/16 x 1 x 1/8 use M-4 or M-8 Mandrel	60	100	08834180137
	80		08834180138
	120		08834180140
5/16 x 1-1/2 x 1/8 use M-9 Mandrel	60	100	08834180156
	80		08834180157
	120		08834180159
3/8 x 3/4 x 1/8 use M-7 Mandrel	60	100	08834180194
	80		08834180195
	120		08834180197
3/8 x 1 x 1/8 use M-8 Mandrel	40	100	08834180211
	50		08834180212
	60		08834180213
	80		08834180214
	100		08834180215
	120		08834180216
	150		08834180217
	180		08834180218
	240		08834180220
	3/8 x 1-1/2 x 1/8 use M-9 Mandrel	36	100
40			08834180229
50			08834180230
60			08834180231
80			08834180232
100			08834180233
120			08834180234
150			08834180235
180			08834180236
240			08834180238
3/8 x 2 x 1/8 use M-10 Mandrel	60	100	08834180250
	80		08834180251
	100		08834180252
	120		08834180253
1/2 x 3/4 x 1/8 use M-7 Mandrel	80	100	08834180270
1/2 x 1 x 1/8 use M-8 Mandrel	40	100	08834180286
	50		08834180287
	60		08834180288
	80		08834180289
	100		08834180290
	120		08834180291
	150		08834180292
	180		08834180293
	240		08834180295
1/2 x 1-1/2 x 1/8 use M-9 Mandrel	36	100	08834180304
	40		08834180305
	50		08834180306
	60		08834180307
	80		08834180308
	100		08834180309
	120		08834180310
	150		08834180311
	180		08834180312
	240		08834180314
1/2 x 1-1/2 x 3/16 use M-16 Mandrel	120	100	08834180919
1/2 x 2 x 1/8 use M-10 Mandrel	60	100	08834180326
	80		08834180327
	100		08834180328
	120		08834180329
	180		08834180331
	240		08834180333
	320		08834180335
1/2 x 2 x 3/16 use M-17 Mandrel	60	100	08834180350
	80		08834180653
	120		08834180338

<i>D X L X H</i>	<i>GRIT</i>	<i>STD. PKG.</i>	TIER: GOOD
			ABRASIVE: Aluminum Oxide
			BACKING: Cotton
<i>PART NO.</i>			
1/2 x 2 x 1/4 use M-22 Mandrel	40	100	08834183168
	80		08834180351
5/8 x 1 x 3/16 use M-15 Mandrel	80	100	08834180364
5/8 x 1-1/2 x 1/8 use M-9 Mandrel	36	100	08834180395
	40		08834180392
	50		08834180393
	60		08834180275
	80		08834180789
5/8 x 1-1/2 x 3/16 use M-16 Mandrel	120		08834180394
	50	100	08834180381
	60		08834180382
	80		08834180383
5/8 x 2 x 1/8 use M-10 Mandrel	60	100	08834182505
	80		08834181080
5/8 x 2 x 3/16 use M-10 Mandrel	50	100	08834180400
	60		08834180401
	80		08834180402
3/4 x 1 x 1/8 use M-8 Mandrel	100		08834180403
	80	100	08834180469
	120		08834181543
3/4 x 1 x 3/16 use M-15 Mandrel	40		08834180456
	80	100	08834180459
	120		08834180461
3/4 x 1-1/2 x 1/8 use M-9 Mandrel	40	100	08834180069
	60		08834180490
	80		08834180527
	120		08834180487
3/4 x 1-1/2 x 3/16 use M-16 Mandrel	36	100	08834180474
	40		08834180475
	50		08834180476
	60		08834180477
	80		08834180478
	100		08834180479
	120		08834180480
180		08834180482	
3/4 x 1-1/2 x 1/4 100/box 400/case use M-21 Mandrel	36	100	08834180907
	60		08834180489
	80		08834180358
	100		08834180523
	120		08834180488
3/4 x 1-1/2 x 3/16 use M-17 Mandrel	150		08834182807
	60	100	08834180791
3/4 x 2 x 1/8 use M-10 Mandrel	40	100	08834180494
	60		08834180496
	80		08834180497
	100		08834180498
3/4 x 2 x 3/16 use M-17 Mandrel	120		08834180499
	60	100	08834180506
	80		08834181297
	100		08834180509
1 x 1-1/2 x 1/8 use M-9 Mandrel	120		08834180507
	60	100	08834180580
	80		08834180584
1 x 1-1/2 x 1/4 use M-21 Mandrel	36	100	08834181195
	60		08834180587
	80		08834180583
1 x 2 x 3/16 use M-17 Mandrel	40	100	08834180589
	60		08834180591
	80		08834180592
1 x 2 x 1/4 use M-22 Mandrel	60	100	08834180603
	80		08834180606
	120		08834180585

CONTINUED

Please refer to the back of this section for mandrels.



Spiral Rolls

- All spiral roll part numbers shown are full tapered, resin bond, half glued
- Half-tapered and sidewall-tapered are available for quotation
- Quarter and full glue are also available for quotation

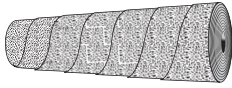

Full Taper

- Especially useful for grinding/polishing of channels, fillets and radii, and deburring small holes
- Full taper used when the area to finished is hard to reach with a full cartridge roll
- The tapered roll conforms to smaller areas
- Fits into irregular concaves, contours, channels

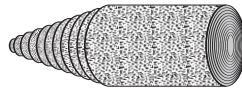

Half Taper

- Used when the area to be finished is not narrow but a beginning point on the roll is needed
- The portion of the roll that is not tapered is then used to finish off the sides



Sidewall Taper

- The portion of the roll that is tapered guides the roll down to the area to be finished
- The sidewall then finishes off the sides

FEATURED PRODUCTS



Merit Blaze Spiral Rolls Full Taper

- With their exclusive ceramic grain technology, grinding aid and X-weight cotton backing, these products outperform all competitive ceramic, zirconia, and aluminum oxide specialty products in today's markets
- Merit Blaze specialties cut cooler and last longer on stainless steel, cobalt, Inconel, titanium, and other hard-to-grind materials

AVAILABILITY

TIER:	BEST
ABRASIVE:	Ceramic Alumina
BACKING:	Cotton
OTHER:	Supersized

D X L X H	GRIT	STD. PKG.	PART NO.
3/8 x 1-1/2 x 1/8 Use M-9 Mandrel	60	100	66261194481
	80		66261194490
	120		66261194491
1/2 x 1-1/2 x 1/8 Use M-9 Mandrel	60	100	66261194484
	80		66261194492
	120		66261194495



Merit Silicon Carbide Spiral Rolls Full Taper

- Sharp silicon carbide grain penetrates tough, difficult-to-grind materials as well as soft, loading materials:
 - titanium
 - masonry
 - composites
 - plastic
 - rubber

AVAILABILITY

TIER:	GOOD
ABRASIVE:	Silicon Carbide
BACKING:	Cotton

D X L X H	GRIT	STD. PKG.	PART NO.
3/8 x 1-1/2 x 1/8 use M-9 Mandrel	60	100	08834189901
	80		08834189904
	120		66261046936
1/2 x 1-1/2 x 1/8 use M-9 Mandrel	60	100	66261185977
	80		08834183460
	120		08834183448

Refer to the back of this section for mandrels.



Merit Aluminum Oxide Spiral Rolls Full Taper

- Especially useful for grinding/polishing of channels, fillets and radii, and deburring small holes
- All spiral roll part number shown are full tapered, resin bond, half glued
- Half-tapered and sidewall tapered are available for quotation
- Quarter and full glue are also available for quotation

AVAILABILITY

TIER: **GOOD**
 ABRASIVE: Aluminum Oxide
 BACKING: Cotton

D X L X H	GRIT	STD. PKG.	PART NO.
3/8 x 1 x 1/8 use M-8 Mandrel	60	100	08834181714
	80		08834181715
	120		08834181717
	180		08834181719
3/8 x 1-1/2 x 1/8 use M-9 Mandrel	50	100	08834181723
	60		08834181724
	80		08834181708
	120		08834181727
	150		08834181728
	180		08834181709
1/2 x 1 x 1/8 use M-8 Mandrel	60	100	08834181734
	80		08834181735
	120		08834181737
	180		08834181739
1/2 x 1-1/2 x 1/8 use M-9 Mandrel	36	100	08834181230
	40		08834181742
	50		08834181743
	60		08834181744
	80		08834181745
	100		08834181746
	120		08834181747
	180		08834181749
	240		08834181750
1/2 x 2 x 1/8 use M-10 Mandrel	60	100	08834181754
	80		08834181755
	120		08834181757

TIER: **GOOD**
 ABRASIVE: Aluminum Oxide
 BACKING: Cotton

D X L X H	GRIT	STD. PKG.	PART NO.
5/8 x 1-1/2 x 1/8 use M-9 Mandrel	100	100	08834181776
	120		08834181777
	240		08834183313
	320		08834181781
5/8 x 1-1/2 x 3/16 use M-16 Mandrel	80	100	08834181444
3/4 x 1-1/2 x 1/8 use M-9 Mandrel	60	100	08834181286
	80		08834180886
3/4 x 1-1/2 x 3/16 use M-16 Mandrel	50	100	08834181807
	60		08834181808
	80		08834181809
	120		08834181811
3/4 x 2 x 3/16 use M-17 Mandrel	60	100	08834181820
1 x 1-1/2 x 1/8 use M-9 Mandrel	60	100	08834181240
1 x 2 x 3/16 use M-17 Mandrel	36	100	08834181875
	60		08834181878
	80		08834181879

Merit Aluminum Oxide Tapered Cone Points



- Tapered cone points are similar to cartridge rolls but their shape lends greater accessibility to many difficult-to-reach work areas
- They are used for deburring holes and in close tolerance work areas
- Popular sizes and mandrels are listed, with additional sizes available upon request

FEATURED PRODUCTS



AVAILABILITY

TIER: **GOOD**
 ABRASIVE: Aluminum Oxide
 BACKING: Cotton

D X L X H	GRIT	STD. PKG.	PART NO.
5/16 x 1-1/2 x 5° Use B-20 Mandrel	80	500	08834180873
	100		08834182043
	120		08834182717
	150		08834186890
	180		08834182535
	240		08834182044
	320		08834182537
3/16 x 1 x 2-1/2° Use K-110 Mandrel	50	500	08834186892
	60		08834186893
	80		08834180918
	100		08834182197
	120		08834182199
	150		08834182200
	180		08834186894
	240		08834186895



Cartridge and Spiral Roll Mandrels

MODEL NO.	PILOT DIA.	PILOT LENGTH	SHANK DIA.	SHANK LENGTH	OVERALL LENGTH	PART NO.
CARTRIDGE AND SPIRAL ROLL MANDRELS						
M-2E	3/32	3/4	1/4	1	3	08834183799
M-2	3/32	1	1/8	1	3	08834181202
M-3	1/8	1/2	1/8	1	2-1/2	08834181203
M-4	1/8	3/4	1/8	1	2-1/2	08834181204
M-5	1/8	1	1/8	1	2-3/4	08834181205
M-6	1/8	1-1/2	1/8	1	2-1/2	08834181206
M-7	1/8	1/2	1/4	1-1/4	2-1/4	08834181207
M-8	1/8	3/4	1/4	1-1/4	2-1/2	08834181208
M-9	1/8	1	1/4	1-1/4	2-3/4	08834181209
M-10	1/8	1-1/2	1/4	1-1/4	3-1/4	08834181210
M-11	1/8	2	1/4	1-1/4	4	08834181211
M-12	3/16	1/2	1/8	1-1/4	2-1/4	08834181212
M-13	3/16	3/4	1/8	1-1/4	2-1/2	08834181213
M-14	3/16	1/2	1/4	1-1/4	2-1/2	08834181214
M-15	3/16	3/4	1/4	1-1/4	2-3/4	08834181215
M-16	3/16	1	1/4	1-1/4	3	08834181216
M-17	3/16	1-1/2	1/4	1-1/4	3-1/2	08834181217
M-18	3/16	2	1/4	1-1/4	4	08834181218
M-19	1/4	1/2	1/4	1-1/4	2-1/2	08834181219
M-20	1/4	3/4	1/4	1-1/4	2-3/4	08834181220
M-21	1/4	1	1/4	1-1/4	3	08834181221
M-22	1/4	1-1/2	1/4	1-1/4	3-1/2	08834181222
M-23	1/4	2	1/4	1-1/4	4	08834181223
M-24	5/16	3/4	1/4	1-1/4	2-3/4	08834181224
M-25	5/16	1	1/4	1-1/4	3	08834181225
M-26	5/16	1-1/2	1/4	1-1/4	3-1/2	08834181226
M-27	5/16	2	1/4	1-1/4	4	08834181227

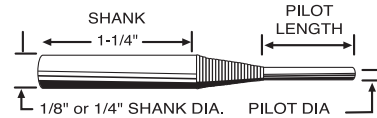

Recommended Pilot Length for Mandrels

3/4 Roll Length	use 1/2 Pilot
1 Roll Length	use 3/4 Pilot
1-1/2 Roll Length	use 1 Pilot
2 Roll Length	use 1-1/2 Pilot

Extra Shank Length Mandrels

MODEL NO.	SHANK LENGTH	OVERALL LENGTH	PART NO.
EXTRAS SHANK LENGTH MANDRELS			
M-8-4	4	5-1/4	08834180116
M-8-6	6	7-1/4	08834180122
M-9-2.5	2-1/2	4	08834180096
M-9-3	3	4-1/2	08834180129
M-9-4	4	5-1/2	08834180074
M-9-6	6	7-1/2	08834180131
M-9-8	8	9-1/2	08834180133
M-10-4	4	6	08834180092
M-10-6	6	8	08834180145

ALL EXTRA LENGTH SHANKS ARE 1/4" DIAMETER



Tapered Cone Point Mandrels

DESCRIPTION	SHANK	PART NO.
CONE POINT MANDRELS		
A-10	1/4	08834181300
B-20	1/4	08834181301
C-30	1/4	08834181302
D-40	1/4	08834181303
E-50	1/4	08834181304
F-60	1/4	08834181305
G-70	1/4	08834181306
H-80	1/4	08834181307
I-90	1/4	08834181308
K-110	1/8	08834181310



Test Kits

Merit Blaze Cartridge Roll Test Kit

- Part No. 66261066726
- Kit includes a variety of our new Merit Blaze cartridge rolls, spiral rolls and mandrels in popular sizes and grits.

Merit A/O Cartridge Roll Test Kit "CR"

- Part No. 08834181061
- Includes over 120 pieces of our most popular sizes, grits and shapes with their appropriate mandrels.



CATEGORY DEFINITION

Square pads, cross pads and overlap slotted discs are all used on high speed pneumatic tools for deburring, blending, cleaning, and polishing applications. All of these abrasive specialties are designed for applications in small, tight, hard-to-access locations on parts that are being finished.

- | | |
|-----------------|---|
| BENEFITS: | <ul style="list-style-type: none"> • Variety of shapes and sizes to fit application and part geometry • Shapes provide flexibility for the application, while eliminating aggressiveness of the sanding action • Cross Pads allow visibility of the surface while sanding, to ensure correct amount of material is removed |
| GRIT RANGE: | 50 – 180 |
| ABRASIVE GRAIN: | Ceramic Alumina, Aluminum Oxide |
| BACKING: | Cotton |
| MAXIMUM RPM: | 1" Diameter – 25,000
1-1/2" to 2" Diameter – 18,000 to 23,000
2-1/2" Diameter – 14,000 to 18,000
3" Diameter – 12,000 to 14,000
4" Diameter – 8,000 to 12,000
5" to 6" Diameter – 5,500 to 7,500 |

APPLICATION/GRIT RECOMMENDATION GUIDE

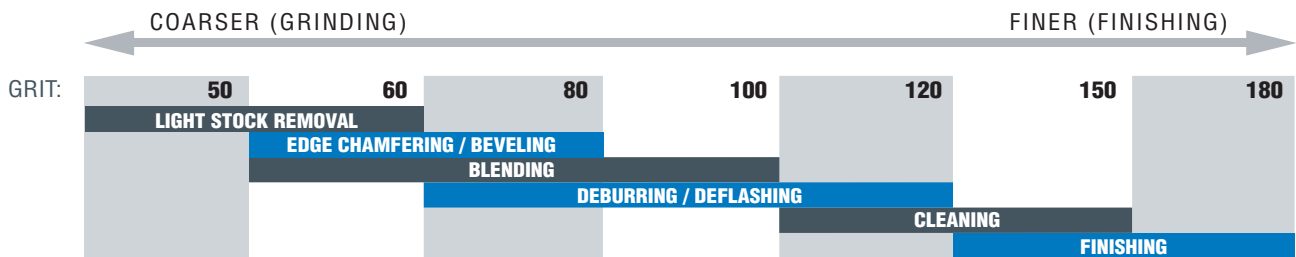

FEATURED PRODUCTS



MERIT BLAZE

BEST FOR HARD-TO-GRIND MATERIALS – STAINLESS STEEL, COBALT, INCONEL, AND TITANIUM

FEATURES

- Next-generation ceramic alumina abrasive grain
- Advanced grinding aid
- Improved resin bond system

BENEFITS

- Significantly faster cut rates
- Resists wear, resulting in 50%-300% longer life
- Greatest productivity
- Cooler cutting, longer life
- Improved grain retention and longer life



MERIT ALUMINUM OXIDE

GOOD FOR MOST ID DEBURRING AND POLISHING APPLICATIONS

FEATURES

- Quality aluminum oxide abrasive grain
- Resin bond system
- Standard quick-change eyelet for easy mounting to quick-change mandrel

BENEFITS

- Versatile; ideal for deburring, chamfering, and polishing most radii, holes, recesses, and cylinder walls
- Good grain retention and life
- Fast, easy mounting and removal; minimal downtime
- Mandrel use increases range and versatility

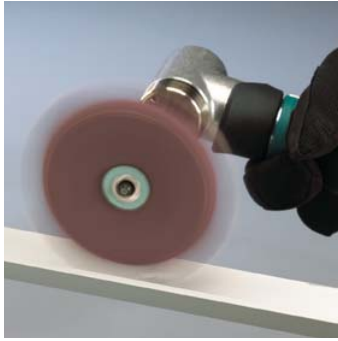

Square Pads

AVAILABILITY

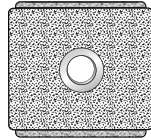

BEST



GOOD

TIER: Merit Blaze Ceramic Alumina
ABRASIVE: Supersized
OTHER:

Aluminum Oxide

L X W X T	EYELET	GRIT	STD. PKG.	PART NO.	PART NO.
1 x 1 x 6 ply	8-32	80	100		08834184826
1 x 1 x 8 ply	8-32	60 80 120	100		08834184828 08834184124 08834184994
1-1/2 x 1-1/2 x 1/2	1/4-20	60 80	100		08834184463 08834184125
2 x 2 x 1/2	1/4-20	60 80 120	100	66261194520 66261194552 66261194554	08834184334 08834184397
2 x 2 x 3/4	1/4-20	50 80	100		08834184487 08834184394
3 x 3 x 1/4	1/4-20	60 80 120	100	66261194531 66261194555 66261194556	08834184882
3 x 3 x 1/2	1/4-20	50 60 80 120	100	66261194528 66261194557 66261194558	08834182152 08834182057 08834184336

Square Pads

- With Merit square pads, corners wear down consistently exposing fresh abrasive; the pad becomes round for less aggressive stock removal
- Grind almost as fast as hard wheels, but are much smoother and easier to control
- For quick blending of channels, fillets, corners, or spotting flat surfaces



Cross Pads

AVAILABILITY

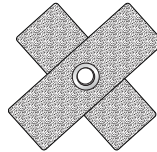

BEST



GOOD

TIER: Merit Blaze Ceramic Alumina
ABRASIVE: Supersized
OTHER:

Aluminum Oxide

L X W X T	PLY	EYELET	GRIT	STD. PKG.	PART NO.	PART NO.
3/4 x 3/4 x 3/8	8	3-48	80	100		08834185578
1 x 1 x 3/8	8	3-48	60 80 100 120	100		08834184943 08834185519 08834184195 08834185164
1-1/2 x 1-1/2 x 1/2	8	8-32	60 80 100 120	100	66261194496 66261194508 66261194511	08834184258 08834184465 08834182196 08834182148
2 x 2 x 1/2	8	8-32	60 80 120	100		08834182156 08834182157 08834182132
2 x 2 x 3/4	8	8-32	60 80 120	100	66261194502 66261194513 66261194516	08834184128 08834184194 08834184285
2 x 2 x 1	8	8-32	120	100		08834184805
2-1/4 x 2-1/4 x 1/2	8	8-32	80	100		08834184402
2-1/2 x 2-1/2 x 3/4	8	8-32	80 120	100		08834184206 08834184074
3 x 3 x 1	8	1/4-20	60 80 120	100	66261194504 66261194549 66261194551	08834182135 08834184119 08834184116
3 x 3 x 1	10	1/4-20	80	100		08834182140
3 x 3 x 1-1/2	10	1/4-20	80	100		08834182184
4 x 4 x 1	8	1/4-20	60 80 120	100		08834184142 08834184135 08834184377
4 x 4 x 1-1/2	8	1/4-20	80 120	100		08834184129 08834184370

Cross Pads

- The shape of Merit's cross pads enables you to see through to the contact area, and provides greater flexibility than square pads to conform to variable internal diameters
- Used for close-tolerance polishing of small radii and channels, deburring, and finishing of bell-mouth configurations
- All pads are furnished with standard quick-change eyelet, as listed
- Plain hole sizes must be specified

Refer to the back of this section for mandrels.



Overlap Slotted Discs

AVAILABILITY

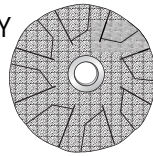

TIER:
ABRASIVE:
OTHER:



BEST



GOOD



GOOD

Ceramic Alumina
Supersized, 2-Ply

Aluminum Oxide
2 Per Set

Aluminum Oxide
4 per Set

DIA.	EYELET	GRIT	STD. PKG.	PART NO.	PART NO.	PART NO.
1	8-32	60 80 100 120 180	100		08834184346 08834184019 08834184224 08834184151 08834185078	08834184085 08834184236
1-1/4	8-32	60 80 100 120	100		08834184270 08834184065 08834184291 08834184084	
1-1/2	8-32	60 80 100 120 180	100	66261195051 66261195368 66261195367	08834184066 08834184079 08834184279 08834186035 08834184498	08834184023
1-3/4	8-32	60 80	100		08834184655 08834184042	
2	8-32	60 80 100 120	100	66261195054 66261195055 66261195056	08834184076 08834184145	
2-1/2	8-32	80	100		08834184444	
3	1/4-20	50 60 80 100 120	100	66261195057 66261195058 66261195059	08834184818 08834184041 08834184077 08834184082 08834184344	
4	1/4-20	60 100 120	100		08834184000 08834184159 08834185155	
4-1/2	1/4-20	120	100		08834184431	
5	1/4-20	100	100		08834184302	

ALL OVERLAP SLOTTED DISCS ARE AVAILABLE (MADE-TO-ORDER) REINFORCED WITH A FIBER WASHER

Quick-Change Mandrels for Overlap Slotted Discs, Square and Cross Pads

CROSS PAD SIZE DIA.	SQUARE PAD SIZE DIA.	OAL	MODEL NO.	THD. SIZE	PART NO.
1/4, 3/8, and 1/2 wide		2-1/2	MM48-4	3-48	08834183162
3/4, 1 wide	Up thru 1-1/2 sq. x 1/2 thick 2 sq. x 1/4 or 3/8 thick	3 4 6	MM32-4 MM-32-4-4 MM-32-4-6	8-32 8-32	08834183163 08834121680 08834121681
All pads 2-1/2 x 1-1/2 and larger	2 sq. x 1/4 or 1/2 thick and larger	3	MM20-4	1/4-20	08834183164

FOR OVERLAP SLOTTED DISCS, CHOOSE A MANDREL WITH THE SAME THREAD SIZE AS THE DISC

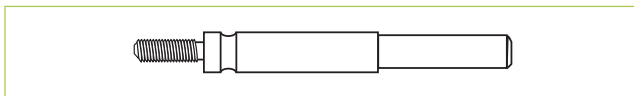

EXTENDED MANDREL

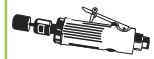

CATEGORY DEFINITION

Flaps of abrasive cloth are stacked, inserted into a holder, and then attached to a mandrel. The flaps are designed to break down during use and reveal the next layer of abrasive. Cloth flaps are mixed with non-woven flaps to create an interleaf bore polisher.





APPLICATIONS: For deburring, sizing, cleaning and polishing the interior diameters of cylinders, tubes and hydraulic fittings. Flaps adjust automatically to inside diameter, polishing the entire surface area with each pass. Bore polishers are self-centering, so they apply equal pressure to full wall of inside diameter. Spring action design gives faster inside diameter cleaning, deburring and polishing to cylinders, deep bores and tubes.

Interleafed bore polishers are designed to polish and finish in one easy application. The abrasive flaps cut, while the non-woven flaps apply a fine finish.

GRIT RANGE: 60 - 240

ABRASIVE GRAIN: Aluminum Oxide

APPLICATION-TO-PRODUCT SHAPE RECOMMENDATION GUIDE

SHAPE	APPLICATION
 <p>Bore Polisher Solid Flaps B-3 Series</p>	<ul style="list-style-type: none"> • For 5/8" to 1" interior diameter bores • 3 abrasive packs 1-1/2" wide, bonded to hub • Use with QC-5 mandrel Part No. 08834154182
 <p>Bore Polisher Solid Flaps B-4 Series</p>	<ul style="list-style-type: none"> • For 1" to 4" interior diameter bores • 4 abrasive packs 1-1/2" wide, bonded to hub • Use with BPM-4 mandrel Part No. 08834154183
 <p>Bore Polisher Solid Flaps B-8 Series</p>	<ul style="list-style-type: none"> • For 2" to 5-7/8" interior diameter bores • 8 abrasive packs 1-1/2" wide, bonded to hub • Use with BPM-8 mandrel Part No. 08834154184
 <p>Bore Polisher Scored Flaps</p>	Available upon request
 <p>Bore Polisher Interleaf</p>	Merit interleaf bore polishers do double duty. Designed to polish and finish in one easy application, they are the ideal choice when close tolerances must be maintained, while giving an interior a polished finish.

APPLICATION/GRIT RECOMMENDATION GUIDE

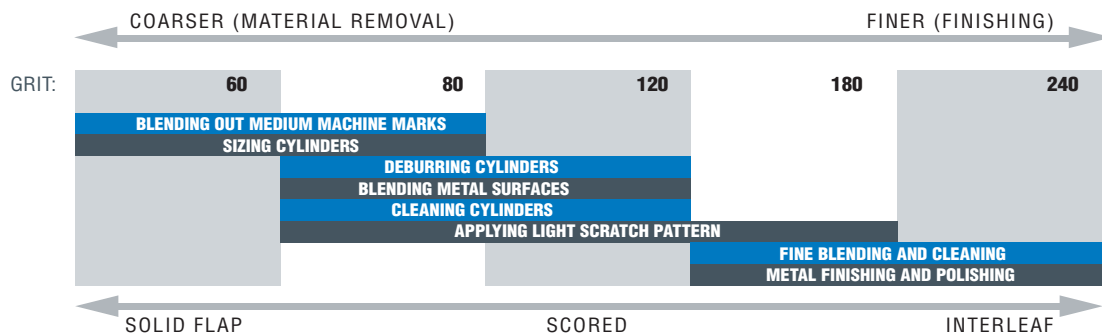



Merit Aluminum Oxide Bore Polishers

AVAILABILITY

TIER: **GOOD**
 ABRASIVE: Aluminum Oxide
 BACKING: X-wt. Cotton/Poly

TIER: **GOOD**
 ABRASIVE: Aluminum Oxide
 BACKING: X-wt. Cotton/Poly

DESCRIPTION	GRIT	MAX. RPM	STD. PKG.	PART NO.
BORE POLISERS – SOLID FLAP B-3 AND B-4 SERIES				
B-305 Fits I.D. 5/8 to 1	60 80 120 180 240	25,000	10	08834154190 08834154191 08834154193 08834154195 08834154197
B-405 Fits I.D. 1 to 1-1/2	60 80 120 180	22,000	10	08834154091 08834154092 08834154093 08834154094
B-410 Fits I.D. 1-1/2 to 2	60 80 120 180 240	20,000	10	08834154100 08834154101 08834154102 08834154103 08834154104
B-415 Fits I.D. 2-1/8 to 2-1/2	60 80 120 180 240	16,000	10	08834154109 08834154110 08834154111 08834154112 08834154113
B-420 Fits I.D. 2-1/2 to 3	60 80 120 180 240	15,000	10	08834154118 08834154119 08834154120 08834154121 08834154122
B-425 Fits I.D. 3-1/8 to 4	60 80 120 180 240	10,000	10	08834154127 08834154128 08834154129 08834154130 08834154131

DESCRIPTION	GRIT	MAX. RPM	STD. PKG.	PART NO.
BORE POLISERS – SOLID FLAP B-8 SERIES				
B-810 Fits I.D. 2 to 2-1/2	60 80 120 180 240	16,000	10	08834154136 08834154137 08834154138 08834154139 08834154140
B-815 Fits I.D. 2-5/8 to 3	60 80 120 180 240	15,000	10	08834154145 08834154146 08834154147 08834154148 08834154149
B-820 Fits I.D. 3-1/8 to 4	60 80 120 180 240	10,000	10	08834154154 08834154155 08834154156 08834154157 08834154158
B-825 Fits I.D. 4-1/4 to 5-1/4	60 80 120 180 240	8,000	10	08834154163 08834154164 08834154165 08834154166 08834154167
B-830 Fits I.D. 5-1/4 to 5-7/8	60 80 120 180 240	8,000	10	08834154172 08834154173 08834154174 08834154175 08834154176

BORE POLISERS – SCORED FLAPS

Available on request

BORE POLISERS – INTERLEAF

B-405 Interleaf Fits ID 1 to 1-1/2	80 180	22,000	10	08834150271 08834150273
B-410 Interleaf Fits ID 1-1/2 to 2	80	20,000	10	08834150275

Mandrels for Bore Polishers

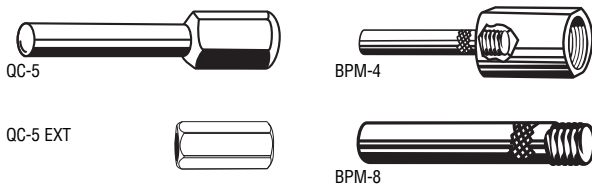

DESCRIPTION	MODEL NO.	THREAD	PART NO.
For B-3 Series	QC-5	5/16-18	08834154182
For B-4 Series	BPM-4	1/2-20	08834154183
For B-8 Series	BPM-8	1/4-20	08834154184
QC-5 Ext.	QC-5 Ext.	5/16-18	08834150573

Extension Mandrels for Bore Polishers

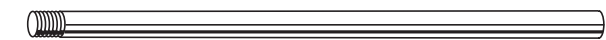

DIA. X L	MODEL NO.	THREAD	PART NO.
1/4 x 4	EM-144	1/4-20	08834154185
1/4 x 6	EM-146	1/4-20	08834154186
1/4 x 8	EM-148	1/4-20	08834154187

To extend a B-3 series bore polisher, attach the QC-5 Ext. to the bore polisher, then attach the desired length extension mandrel above to the QC-5 Ext. To extend a B-4 series bore polisher, attach the adapter piece of the BPM-4 mandrel to the bore polisher, then attach the desired length extension mandrel above to the BPM-4 adapter piece. To extend a B-8 series bore polisher, attach the desired length extension mandrel above directly to the bore polisher.

Test Kit

Bore Polisher Test Kit “BP”

- Part No. 08834154181
- Contains ten bore polishers and two mini 1/4"-20 thread flap wheels in assorted sizes and grits for finishing 1" to 5" interior diameters, and mandrel for 1/4" chuck.



CATEGORY DEFINITION

FlexDrum's abrasive cloth sweeps away flaws. Its extreme longevity and perfect balance make it well-suited for automatic as well as offhand use. Hubs and abrasive segments can be combined to fit your job perfectly.

APPLICATIONS:	Blending out parting lines on castings, smoothing out pre-ground welded areas, removing burrs and work flaws, graining stainless, brush-finishing and satin-finishing aluminum, removing rust, deflashing molded plastic and rubber parts, and preparing surfaces for painting or plating.
SIZE RANGE:	Diameter of loaded FlexDrum: 8" – 18" Width of FlexDrum: 1-1/2" – 12" Custom die-cut segments as well as extra wide segments, in widths up to 144" are also available
GRIT RANGE:	50 – 240
BOND:	Resin or glue
BACKING:	Heavyweight cotton
ABRASIVE GRAIN:	Premium Aluminum Oxide



SHAPE/APPLICATION RECOMMENDATION GUIDE



Plain Segment

- For flat or mildly contoured surfaces



1/4 Scored (SC) Segment

- Great for complex parts
- Provides a fine finish



1/2 Slash (SL) Segment

- Great for mild and moderate contours

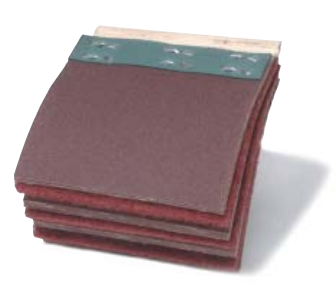

Interleaf Segment

- Available upon request

LOADING FLEX DRUM HUBS



FlexDrum hub end plate removes for easy loading of abrasive segments.



Custom profiled segments eliminate break-in resulting in maximum productivity. Contact your sales representative for more information.

Plain Segments – for flat or mildly curved surfaces

AVAILABILITY				TIER: GOOD							
				BRAND: Merit		Merit		Merit		Merit	
				ABRASIVE: A/O		A/O		A/O		A/O	
				GRIT: 50		60		80		100	
WIDTH	TRIM LENGTH*	STD. PKG.	PART NO.	PART NO.	PART NO.	PART NO.	PART NO.	PART NO.	PART NO.	PART NO.	
1-1/2	2-3/4	12	08834155002	08834155003	08834155004	08834155005	08834155006	08834155008	08834155010		
2	2-3/4	12	08834155013	08834155014	08834155015	08834155016	08834155017	08834155019			
2	4	20	08834155312	08834155313	08834155314	08834155315	08834155316	08834155318			
2	5	20		08834155568	08834155569		08834155571	08834155573	08834155575		
3	2-3/4	12	08834155025	08834155026	08834155027	08834155028	08834155029	08834155031			
3	4	20	08834155324	08834155325	08834155326		08834155328	08834155330			
3	5	20		08834155579			08834155582	08834155584			
4	2-3/4	12	08834155036	08834155037	08834155038	08834155039	08834155040	08834155042	08834155044		
4	4	20	08834155336	08834155337	08834155338	08834155339	08834155340	08834155342	08834155344		
4	5	20		08834155590	08834155591		08834155593	08834150390	08834155953		

1/4 Scored Segments – great for complex parts and provide a fine finish

AVAILABILITY				TIER: GOOD							
				BRAND: Merit		Merit		Merit		Merit	
				ABRASIVE: A/O		A/O		A/O		A/O	
				GRIT: 50		60		80		100	
WIDTH	TRIM LTH.*	SCORE	STD. PKG.	PART NO.	PART NO.	PART NO.	PART NO.	PART NO.	PART NO.	PART NO.	
1-1/2	2-3/4	1/4	12	08834155082	08834155083	08834155084	08834155085	08834155086	08834155088	08834155090	
2	2-3/4	1/4	12	08834155094	08834155095	08834155096	08834155097	08834155098	08834155100	08834155102	
3	2-3/4	1/4	12	08834155106	08834155107	08834155108	08834155109	08834155110	08834155112		
4	2-3/4	1/4	12	08834155117	08834155118	08834155119	08834155120	08834155121	08834155123		

1/2 Slashed Segments – for mild and moderate contours

AVAILABILITY				TIER: GOOD							
				BRAND: Merit		Merit		Merit		Merit	
				ABRASIVE: A/O		A/O		A/O		A/O	
				GRIT: 50		60		80		100	
WIDTH	TRIM LTH.*	SLASH	STD. PKG.	PART NO.	PART NO.	PART NO.	PART NO.	PART NO.	PART NO.	PART NO.	
2	4	1/2	20		08834155420	08834155421	08834155422	08834155423	08834155425	08834155427	
2	5	1/2	20	08834155635		08834155637		08834155639			
3	4	1/2	20	08834155430	08834155431	08834155432	08834155433	08834155434	08834155436	08834155438	
3	5	1/2	20	08834155646		08834155648					
4	4	1/2	20	08834155443	08834155444	08834155445	08834155446	08834155447	08834155449	08834155451	
4	5	1/2	20		08834155658	08834155659		08834155661	08834150383		

*TRIM LENGTH IS THE ACTUAL USABLE LENGTH OF SEGMENT WHEN LOADED



FlexDrums can be used for polishing large IDs. Just load half the segments with a wheel diameter 1/2" to 1" larger than the ID of your workpiece.

Hub Units

- FlexDrum hubs are perfectly balanced, last indefinitely and are available in widths from 1-1/2" to 12"
- Extra wide widths available up to 144"

MODEL NO.	D X W	ARBOR HOLE/ THREAD	SEGMENTS PER HUB	PART NO.
FLEXDRUM HUB UNITS				
81.5-B	2-3/8 x 1-1/2	1 AH	12	08834140065
82-B	2-3/8 x 2	1 AH 5/8-11 THD	12	08834141049 08834140048
83-B	2-3/8 x 3	1 AH 5/8-11 THD	12	08834141018 08834140034
84-B	2-3/8 x 4	1 AH 5/8-11 THD	12	08834140066 08834140049
122-B	4 x 2	1-1/4 AH	20	08834140050
123-B	4 x 3	1-1/4 AH	20	08834140051
124-B	4 x 4	1-1/4 AH	20	08834140061
142-B	6 x 2	1-1/4 AH	30	08834140062
143-B	6 x 3	1-1/4 AH	30	69957399208
144-B	6 x 4	1-1/4 AH	30	08834141060
840-B2	8 x 2	1-1/4 AH	40	63642592550
840-B4	8 x 4	1-1/4 AH	40	63642592548



**2-3/8" DIAMETER HUB
WITH 1" ARBOR HOLE**
8" WHEEL WHEN LOADED



**2-3/8" DIAMETER HUB ALSO
AVAILABLE WITH 5/8"-11 ARBOR**
8" WHEEL WHEN LOADED



4" DIAMETER HUB
12" WHEEL WHEN LOADED



8" DIAMETER HUB
16" OR 18" WHEEL WHEN LOADED



6" DIAMETER HUB
14" OR 16" WHEEL WHEN LOADED

FlexDrum Reference Charts

FlexDrum can be mounted on any type of arbor.

WEIGHTS

WEIGHT OF HUBS*

4 diameter hub	1.5 lbs./inch of width
6 diameter hub	2 lbs./inch of width
8 diameter hub	2.5 lbs./inch of width

WEIGHT OF HUBS WITH SEGMENTS*

4 diameter hub	3.4 - 4 lbs./inch of width
6 diameter hub	5 - 5.5 lbs./inch of width
8 diameter hub	6.75 - 7 lbs./inch of width

*APPROXIMATE VALUES. ACTUAL WEIGHT WILL DEPEND ON ABRASIVE TYPE AND OVERALL WIDTH OF HUB.

FLEXDRUM MAXIMUM RPM

WHEEL DIAMETER	MAXIMUM RPM
8	4,500
12	3,000
14	2,500
16	2,200
18	2,000

RECOMMENDED H.P. REQUIRED

HUB	H.P.
4 diameter hub	1/2 H.P. /inch of width
6 diameter hub	3/4 H.P./inch of width
8 diameter hub	1 H.P./inch of width

RECOMMENDED SURFACE FEET PER MINUTE FOR USING FLEXDRUM WHEELS ON VARIOUS MATERIALS

MATERIAL	SFPM
Mild Steel	5,000
Stainless Steel	6,500
Alloy Steel	5,000
Titanium	3,500
Hard Aluminum	5,500
Nonferrous	5,000
Rubber	4,500
Hardwood (edge breaking)	4,000
Softwood	3,500
Thermoplastic	3,000



FLEXDRUM HUB SPECIFICATION CHART

	82-B	121-B	141-B	840-B
Diameter of Finished Wheel	8	12	14 or 16	16 or 18
Diameter of Hub Alone	2-3/8	4	6	8
Arbor Hole	1 or 5/8-11 thd	3/4 to 1-3/4	1 to 3-1/2	1-1/4 to 5
Segments Per Hub	12	20	30	40

HOW TO DETERMINE DIAMETER OF FINISHED FLEXDRUM

HUB DIAMETER	+	TRIM LENGTH (X2)	=	FINISHED WHEEL
2-3/8		2-3/4		8
4		4		12
4		5		14
6		4		14
6		5		16
8		4		16
8		5		18

TECHtip

For surface feet per minute, use the following calculation: SFPM=.262 x DIA (in inches) x RPM.





BLAZE
RAPID
STRIP

VORTEX
RAPID
FINISH

RAPID
FINISH



CATEGORY DEFINITION

Non-woven right angle discs have three components: strong synthetic fiber mesh and quality abrasives, bonded together by a smear-resistant adhesive. Rapid Strip discs have an open web construction that enables aggressive cutting action while inherently maintaining a cool, non-loading surface. Rapid Finish discs have a very tight unitized construction for deburring and finishing. Rapid Prep and Surface Preparation discs have a more open weave that excels in preparation and cleaning of a surface. Each product provides excellent cutting action while improving surface finish.

The non-woven web is attached to a fiberglass backing plate (Rapid Strip/Rapid Finish/Rapid Prep depressed center wheels) for direct mounting or onto a woven substrate backing (Surface Prep discs) for mounting on a rubber back-up pad.

APPLICATIONS:	Medium-to-light material removal, deburring, blending, cleaning, finishing, and polishing
SIZE RANGE:	4-1/2" – 7" / 7/8" plain hole or 5/8"-11 discard mount
GRIT RANGE:	X-Coarse, Coarse, Medium, Fine, Very Fine
ABRASIVE GRAIN:	Ceramic Alumina, Silicon Carbide, Aluminum Oxide
BACKING PLATE:	Fiberglass (Rapid Strip, Rapid Finish and Rapid Prep)
BACK-UP PAD:	Rubber (Surface Prep)

WHY CHOOSE NON-WOVEN RIGHT ANGLE DISCS?

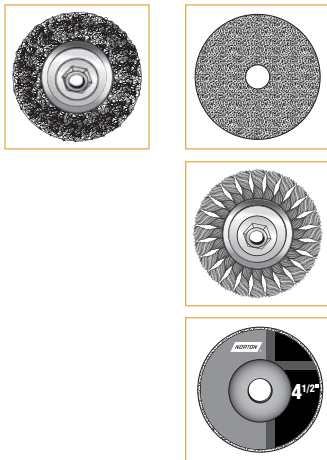

Non-Woven Right Angle Discs vs. Fiber Discs, Wire Wheels, and Depressed Center Wheels

- Deburring, blending and finishing done with one product to reduce the number of steps
- To provide a controlled, sustained finish
- To prevent undercutting and gouging
- To provide a cooler grinding action to lessen the chance of warping or discoloration
- When loading is an issue with fiberglass, adhesives and soft metals
- For stripping coatings and paint off of hard materials like concrete, cement and stone
- Less vibration and quieter for high operator acceptance
- To provide a safe alternative to wire brushes

MATERIAL/APPLICATION-TO-PRODUCT RECOMMENDATION GUIDE

	BEST HIGHEST PRODUCTIVITY LOWEST TOTAL COST	BETTER EXCELLENT BLEND OF PERFORMANCE & PRICE	GOOD CONSISTENT PERFORMANCE LOW INITIAL PRICE
Removing scale and coarse welding marks Removing coatings, epoxy/glue, paint and other clogging material Removing rust, oxidation, corrosion and residue Removing parting lines and seams on fiberglass parts Removing paint/graffiti from concrete/stone	Blaze Rapid Strip Ceramic X/Crse	Rapid Strip S/C X-Coarse	PowerStrip S/C X-Coarse
Removing weld marks and weld splatter Stainless steel deburring and cleaning Removing small flashings and parting lines	Blaze Rapid Strip Ceramic X/Crse Vortex Rapid Finish A/O Medium	AVOS Surface Prep A/O Coarse	Rapid Finish A/O Medium Surface Prep A/O Coarse
Surface preparation before coatings/plating Light cleaning	Blaze Rapid Strip Ceramic X/Crse Vortex Rapid Finish A/O Medium	AVOS Surface Prep A/O Medium	Rapid Prep A/O Medium Surface Prep A/O Medium
Cleaning and prepping welds Removing blemishes after welding stainless	Blaze Rapid Strip Ceramic X/Crse Vortex Rapid Finish A/O Medium	AVOS Surface Prep A/O Medium	Rapid Finish A/O Fine Surface Prep A/O Medium
Blending and finishing all metal parts Creating decorative finishes on stainless steel Final finishing and polishing	Blaze Rapid Strip Ceramic X/Crse	AVOS Surface Prep A/O Very Fine	Rapid Finish S/C Very Fine Surface Prep A/O Very Fine
Final finishing/polishing where high conformability is needed	–	–	Abrasive Brush

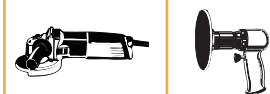

APPLICATION/PRODUCT RECOMMENDATION GUIDE

	MOST AGGRESSIVE / LEAST CONFORMABLE			LEAST AGGRESSIVE / MOST CONFORMABLE	
TYPE 27 DISC	BLAZE RAPID STRIP RAPID STRIP, POWERSTRIP	VORTEX RAPID FINISH RAPID FINISH A/O MEDIUM	RAPID FINISH A/O FINE RAPID PREP	RAPID FINISH S/C VERY FINE	ABRASIVE BRUSH
DISCS WITH BACK-UP PAD		SURFACE PREP A/O COARSE	SURFACE PREP A/O MEDIUM	SURFACE PREP A/O VERY FINE	
SCALE REMOVAL	BEST CHOICE				
STOCK REMOVAL	BEST CHOICE	SECOND CHOICE			
HEAVY DEBURRING	SECOND CHOICE	BEST CHOICE			
LIGHT DEBURRING		BEST CHOICE	SECOND CHOICE		
LIGHT FINISHING		SECOND CHOICE	BEST CHOICE		
BLENDING			BEST CHOICE	SECOND CHOICE	
FINISHING			SECOND CHOICE	BEST CHOICE	
POLISHING				BEST CHOICE	SECOND CHOICE

CROSS REFERENCE GUIDE

	STRIPPING EXTRA COARSE		SURFACE FINISHING COARSE – MEDIUM – FINE			SURFACE PREP VERY FINE
NORTON	BEST Blaze Rapid Strip	BETTER Rapid Strip	GOOD	BEST Vortex Rapid Finish	GOOD Rapid Finish Surface Prep	GOOD Abrasive Brush
MERIT			PowerStrip			
3M	Clean & Strip Clean Strip XT Surface Cond.	Clean & Strip	–	–	–	SL Surface Conditioning Bristle Discs
Bibielle	–	SDRR Strip-It Red	SDR Strip-It	–	Unitized	–
Camel	–	EZ Strip Red	EZ Strip Black	–	–	–
Flexovit	–	–	Clean & Strip	–	–	–
Hermes	–	–	Webrax	–	–	–
Pearl	–	–	S/C Stripping	–	–	Surface Preparation
Pferd	–	–	Policlean	–	Poliflex PUR	–
Sait	–	–	Sait-Strip	–	Unitized	–
Standard	–	–	Cleaning	–	Unitized	–
Superior	–	–	Stripping	–	Unitized	–
Walter	–	–	FX Cleaning	–	–	Blendex Surface Conditioning



Blaze Rapid Strip Type 27 Depressed Center Discs

Strip/blend cast iron, steels, aluminum, fiberglass and composites

- Heavy coating of easily identifiable, orange-colored Norton SG Blaze ceramic alumina long-lasting grain and advanced resin bond
- 2X as substantial as competitive discs; lasts 2X (plus) as long
- Will not shed on heavily rust-encrusted pieces
- Extremely versatile; use one disc; stiff enough to stand abuse, but soft enough to prevent gouging and rework
- Use on edge for blending weld root forms
- Apply some pressure to strip-remove coatings; lighter pressure finishes like a surface finishing disc
- Fewer safety, ergonomic, and environmental issues due to fewer change-outs, less downtime, and less production waste/landfill scrap
- Open structure; will not load on sticky coatings, adhesives, and soft metals (e.g. aluminum), or snag and shed like a lanuk or fiber disc

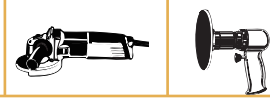

FEATURED PRODUCTS AND AVAILABILITY



RAPID STRIP NON-WOVEN DEPRESSED CENTER DISCS – TYPE 27

BETTER CHOICE FOR QUICK AND EASY ROUGH CLEANING AND STRIPPING OF ALL MATERIALS

FEATURES

- Thick, strong, synthetic fibers and extra coarse silicon carbide abrasive bonded with a durable, smear-resistant adhesive
- Open web construction

BENEFITS

- Aggressive cutting, cleaning and stripping of all materials
- Minimizes loading

AVAILABILITY

	TIER: BEST	BETTER	GOOD
BRAND:	Norton	Norton	Merit
TRADENAME:	BLAZE RAPID STRIP	RAPID STRIP	POWERSTRIP
ABRASIVE:	Ceramic Alumina	Silicon Carbide	Silicon Carbide
GRIT SIZE:	60	36 - 50	36 - 50
GRADE:	X-Coarse	X-Coarse	X-Coarse
TYPE/BACKING:	Type 27/Fiberglass	Type 27/Fiberglass	Type 27/Fiberglass

SIZE (D X H)	MAX. RPM	STD. PKG.	PART NO.	PART NO.	PART NO.
4-1/2 x 5/8-11	12,000	10	66254498101	66261009585	08834197038
4-1/2 x 7/8	12,000	10	66623303783	66261009649	08834192122
5 x 5/8-11	11,000	10	66623303915	66254473456	
5 x 7/8	11,000	10	66623303916	66261030655	
7 x 5/8-11	8,000	10	66623303919	66261009650	08834197040
7 x 7/8	8,000	10	66623303920	66261009586	08834196415



VORTEX RAPID FINISH DEPRESSED CENTER DISCS – TYPE 27

REVOLUTIONARY TECHNOLOGY FOR HEAVY DEBURRING AND FINISHING

FEATURES

- High-performance engineered abrasive
- New bond technology
- Controlled porosity

BENEFITS

- Aggressive, fast stock removal cut rate while providing a fine finish
- Twice the wheel life over conventional unified wheels, with minimal shedding
- Consistent performance with no smearing
- Cooler and improved cut rate

AVAILABILITY

	TIER: BEST	GOOD	GOOD	GOOD	GOOD
BRAND:	Norton	Norton	Norton	Norton	Norton
TRADENAME:	VORTEX RAPID FINISH	RAPID FINISH	RAPID FINISH	RAPID FINISH	RAPID PREP
ABRASIVE:	Engineered A/O	Aluminum Oxide	Aluminum Oxide	Silicon Carbide	Aluminum Oxide
GRIT SIZE:	100-120	150-180	220-280	320-400	150-180
GRADE:	Medium	Medium	Fine	Very Fine	Medium
TYPE/BACKING:	Type 27/Fiberglass	Type 27/Fiberglass	Type 27/Fiberglass	Type 27/Fiberglass	Type 27/Fiberglass

SIZE (D X H)	MAX. RPM	STD. PKG.	PART NO.	PART NO.	PART NO.	PART NO.	PART NO.
4-1/2 x 5/8-11	12,000	10	66254429243	66261023947	66261023946	66261023943	66261023949
4-1/2 x 7/8	12,000	10	66254429268	66261020548	66261020547	66261020546	66261020549

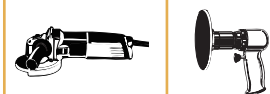

FEATURED PRODUCTS AND AVAILABILITY



AVOS SURFACE PREP SPEED-LOK DISCS

BETTER CHOICE FOR LIGHT DEBURRING, CLEANING, AND FINISHING

FEATURES

- Patented hole design
- Scooped holes
- 15 degree angle back-up pad

BENEFITS

- Allows interrupted cut which reduces heat up to 30% over standard surface preparation discs
- Cool cutting results in longer disc life
- Provides complete vision into the grinding zone
- Operators can grind more accurately with less re-work
- Create air flow to pull loose abrasive and swarf away from work surface grinding zone – resulting in extended disc life
- Grinding at 5°-15° angle allows greater utilization of disc surface
- Eliminates gouging of workpiece

AVAILABILITY

TIER:		BETTER	BETTER	BETTER	GOOD	GOOD	GOOD
BRAND:		Norton	Norton	Norton	Norton	Norton	Norton
TRADENAME:		AVOS SURFACE PREP	AVOS SURFACE PREP	AVOS SURFACE PREP	SURFACE PREP	SURFACE PREP	SURFACE PREP
ABRASIVE:		Aluminum Oxide	Aluminum Oxide	Aluminum Oxide	Aluminum Oxide	Aluminum Oxide	Aluminum Oxide
GRIT SIZE:		60-80	150-180	320-400	60-80	150-180	320-400
GRADE:		Coarse	Medium	Very Fine	Coarse	Medium	Very Fine
ATTACHMENT		Speed-Lok	Speed-Lok	Speed-Lok	7/8" Hole	7/8" Hole	7/8" Hole
SIZE (D X H)	STD. PKG.	PART NO.	PART NO.	PART NO.	PART NO.	PART NO.	PART NO.
4-1/2"	40	66261010447	66261010448	66261010449	66254473868	66261051054	66254473867
5"	40	66261009427	66261009428	66261009429	66261008293	66261017123	66254469077
7"	40	66261009430	66261009431	66261009432	66261008953	66254473870	66261069358

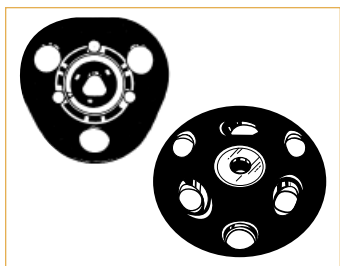

DESCRIPTION

AVOS SPEED-LOK BACK-UP PADS

	MAX. RPM	STD. PKG.	PART NO.
4-1/2" x 5/8-11 (triangular)	13,000	5	63642502985
5 x 3/8-24 Pistol Grip* (triangular)	20,000	5	63642503029
5 x 5/8-11 (triangular)	13,000	5	63642502517
5 x 7/16-20 Pistol Grip* (triangular)	20,000	5	63642503030
7 x 5/8-11 Medium (round)	8,600	5	63642504874

* USE ON AIR PNEUMATIC AND HIGH-SPEED PISTOL GRIP SANDERS.



NON-WOVEN ABRASIVE BRUSHES – TYPE 27

USE WHERE MAXIMUM CONFORMABILITY IS NEEDED

FEATURES

- Feature tough, flexible nylon filaments embedded with abrasive grain

BENEFITS

- Provide finishing and polishing where maximum conformability is needed

AVAILABILITY

TIER:		GOOD	GOOD
BRAND:		Norton	Norton
TRADENAME:		ABRASIVE BRUSH	ABRASIVE BRUSH
ABRASIVE:		Silicon Carbide	Silicon Carbide
GRIT SIZE:		80	120
GRADE:		Fine	Very Fine
BACK-UP PAD:		Rubber Back-up Pad	Rubber Back-up Pad
SIZE (D X H)	MAX. RPM	STD. PKG.	PART NO.
7 x 1 x 7/8	6,000	5	66261058830
			66261058834

USE WITH AIR-COOLED RUBBER BACK-UP PAD AND RETAINER NUT

SURFACE PREP DISC AND ABRASIVE BRUSH BACK-UP PADS

4-1/2" Medium	11,000	5	63642502122
5" Medium	10,000	5	63642543421
7" Medium	8,600	5	63642543422
#103 Retainer Nut		10	63642543463



CATEGORY DEFINITION

Merit and Norton non-woven discs are a combination of strong synthetic mesh and quality abrasives, bonded together by a smear-resistant adhesive. They are ideal for use on portable tools to clean and remove imperfections on metal surfaces, clean, deburr or finish a variety of surfaces, blend weld seams, or create decorative finishes. The open construction of the non-woven material enables aggressive cutting action and improved surface finish while maintaining its non-loading feature.

APPLICATIONS:	Medium-light stock removal, beveling, deburring/deflashing, rust removal, blending, cleaning and finishing, polishing
SURFACE FINISHING:	Surface Stripping, Surface Deburring & Blending, Surface Preparation, Buffing, Felt Polishing
MATERIALS:	
SIZE RANGE:	3/4" – 8" diameter
GRIT RANGE:	X-Coarse, Coarse, Medium, Fine, Very Fine
ABRASIVE GRAIN:	Ceramic Aluminas, Aluminum Oxide, Silicon Carbide
ATTACHMENT:	Quick-Change Type TS (Type II), Type TR (Type III), and Type TP (Type I), Hook and Loop, and Arbor Hole
BACK-UP PADS:	Rubber with hardness variations for different applications



QUICK-CHANGE ATTACHMENT SYSTEMS AND CROSS REFERENCE GUIDE

Type TS (Type II)

- Features a turn-on/turn-off style fastener
- Fastener is made of metal
- Equivalent to Standard Abrasives' SocAtt® locking system



Type TR (Type III)

- Features a roll-on/roll-off style fastener
- Fastener is made of plastic
- Equivalent to 3M™ Roloc™ fastening system



Type TP (Type I)

- Snap-on/snap-off system which enables you to change discs quickly and safely, reducing downtime and operating expenses
- Fastener is made of nylon



MERIT

Type II

Type III

Type I

NORTON

TS

TR

TP

3M	Roloc TS/TSM	Roloc TR	Roloc TP
Standard	TS (SocAtt)	TR (Lockit)	TP (ClickOn)
Superior	Type S	Type R	–
Arc	Type S	Type R	Type P
Pferd	Type CD	Type CDR	–
Sait	SAIT-LOK	SAIT-LOK-R	–
Camel	Turn On	Roll On	–
Klingspor	QMC	QRC	–
Garryson	Type S	Type R	–

APPLICATION/GRIT RECOMMENDATION GUIDE

	← MOST AGGRESSIVE				→ LEAST AGGRESSIVE	
MERIT	POWERSTRIP	DEBURRING & BLENDING	AG, GD SURFACE PREP	GD, XC SURFACE PREP	HS BUFFING, BUFFING	FELT POLISHING
NORTON	BLAZE RAPID STRIP RAPID STRIP	VORTEX RAPID BLEND VORTEX & NEX DEBURRING & BLENDING	STE-CS, STE-VS SURFACE PREP	STE-VS, STE SURFACE PREP		
SCALE REMOVAL	BEST CHOICE					
STOCK REMOVAL	BEST CHOICE		SECOND CHOICE			
HEAVY DEBURRING	SECOND CHOICE		BEST CHOICE			
LIGHT DEBURRING			BEST CHOICE		SECOND CHOICE	
LIGHT FINISHING			BEST CHOICE		SECOND CHOICE	
BLENDING			BEST CHOICE		SECOND CHOICE	
CLEANING			SECOND CHOICE		BEST CHOICE	
FINISHING					BEST CHOICE	
POLISHING						BEST CHOICE

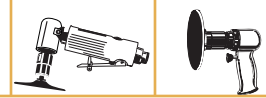

CROSS REFERENCE GUIDE

	STRIPPING		HEAVY/LIGHT DEBURRING		LIGHT DEBURRING/BLENDING/CLEANING/FINISHING			POLISHING	
MERIT	BEST	GOOD PowerStrip	BEST	BETTER Deburring & Blending	BEST AG Surface Prep	BETTER GD Surface Prep	GOOD XC Surface Prep	GOOD HS Buffing Buffing	GOOD Felt Polishing
NORTON	Blaze Rapid Strip	Rapid Strip	Vortex Rapid Blend Vortex Deburring & Blending	NEX Deburring & Blending	STE-CS Surface Prep	STE-VS Surface Prep	STE Surface Prep		
3M	Clean & Strip Clean Strip XT	-	-	EXL Unitized	Surface Cond SL	Surface Cond SE	Surface Cond	-	-
Standard		Cleaning Disc	-	500-900 Series Unitized	FE	GP	RC	Buff & Blend - HS Buff & Blend	Felt Polishing
Fiberal/SIA			-		Meteor	Type B	Type C	-	-
Superior		Type R	-	XL Unitized	FD	GD	CC	HS, HD A/O	F LT
Arc		Arcstrip	-	-	-	-	Surface Cond	Blend & Finish	-
Pferd		Policlean	-	-	-	Finishing Disc - Hard	Finishing Disc - Soft	-	Felt Discs
Sait		SAIT-Strip	-	-	-	Heavy Duty	General Purpose	Sand-Light Blending	Buffing Disc
Camel		EZ Strip - Black	-	-	-	-	-	-	-
Klingspor		Strip-It Black	-	-	-	-	-	-	-
Garryson			-	-	-	-	Surface Cond	-	-
Bibielle			-	BUR Unitized	-	-	DCR	-	-

ABRASIVE/GRIT/DENSITY KEY

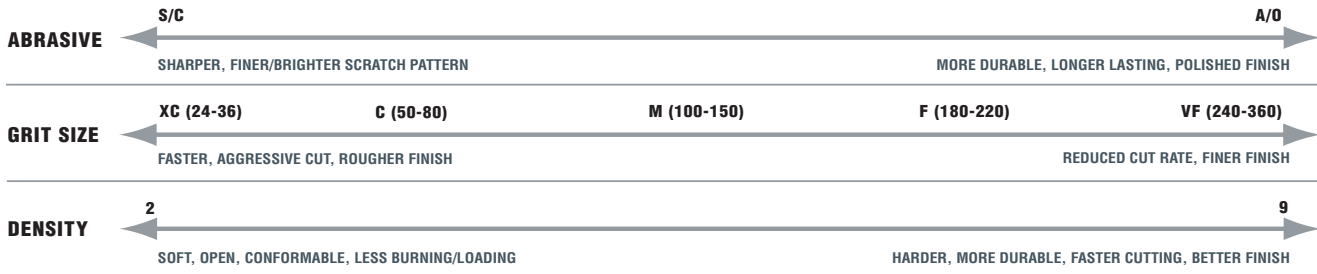

FEATURED PRODUCTS AND AVAILABILITY



Quick-Change Surface Stripping Discs

- Surface Stripping material provides a unique combination of aggressive performance, long life and improved finish. It is ideal for removing coatings on a variety of substrates, such as wood, metal and plastics.
- Incorporated with extruded nylon fibers, flexible resin technology, and extra-coarse abrasive grains, these discs outperform traditional coated abrasive products, leaving a thoroughly cleaned surface, which ensures excellent adhesion in subsequent processes such as coating, painting and soldering.
- NEW! Blaze Rapid Strip:** 2X as substantial as competitive discs; lasts 2X (plus) as long. Stiff enough to stand abuse; soft enough to prevent gouging and rework. Apply some pressure to strip/remove coatings; lighter pressure finishes like a surface finishing disc. Will not load on sticky coatings, adhesives, and soft metals, or snag and shed like a lanuk or fiber disc.

TIER:	BEST	BETTER	GOOD	GOOD
BRAND:	Norton	Norton	Merit	Merit
TRADENAME:	BLAZE RAPID STRIP	RAPID STRIP	POWERSTRIP	POWERSTRIP
ABRASIVE:	Ceramic Alumina	Silicon Carbide	Silicon Carbide	Silicon Carbide
GRADE:	XC	XC	XC	XC
ATTACHMENT:	TR (Type III)	TR (Type III)	TS (Type II)	TR (Type III)

DIAMETER	MAX. RPM	STD. PKG.	PART NO.	STD. PKG.	PART NO.	PART NO.	PART NO.
2 x 1/2	15,500	25	66623303912	10	66261013402	08834167724	08834163514
3 x 1/2	12,000	25	66261096557	10	66261013403	08834167725	08834163513
4 x 1/2	8,000	5	66623303921	10	66261016580	08834167726	08834167722



FEATURED PRODUCTS AND AVAILABILITY

Deburring & Blending Discs



NEW

VORTEX RAPID BLEND DISCS

REVOLUTIONARY TECHNOLOGY FOR HEAVY DEBURRING AND FINISHING

FEATURES

- Proprietary Vortex aluminum oxide aggregate grain
- Special resin chemistry
- 3D construction: abrasive is distributed throughout the entire conformable disc (top, bottom and side)

BENEFITS

- Performs the medium and very-fine grit steps of traditional discs in an easy one-step operation
- Resists shedding when used on sharp edges, making it ideal for deburring
- All three faces can be used – versus competitive discs' one bottom layer of abrasive
- 3 - 8 times the life of competitive surface blending discs
- Fewer safety, ergonomic, and environmental issues due to fewer change-outs, less downtime, and less production waste/landfill scrap
- No smearing because edge has no scrim

TIER:	BEST	BEST	BEST	BETTER	GOOD
BRAND:	Norton	Norton	Norton	Norton	Merit
TRADENAME:	VORTEX RAPID BLEND	VORTEX RAPID BLEND	VORTEX DEBURR/BLEND	NEX DEBURR/BLEND	MERIT DEBURR/BLEND
ATTACHMENT:	TR (Type III)	TS (Type II)	TR (Type III)	TR (Type III)	TR (Type III)

SIZE (D X T)	ABR.	GRIT	DENSITY	MAX. RPM	STD. PKG.	PART NO.	PART NO.	PART NO.	PART NO.	PART NO.
1 x 1/4	A/O	M	1	35,100	100	66254497806 NS				
1-1/2 x 1/4	A/O	M	1	30,100	80	66254497807 NS				
2 x 1/8	A/O	C	7-9	22,000	60				66261014921	
	A/O	M	2-3	22,000	60				66261014897	
	A/O	M	4-6	22,000	60			66254425632	66261014911	
	A/O	M	7-9	22,000	60			66254433509	66261014935	
	S/C	F	2	22,000	60				66261014889	
	S/C	F	3	22,000	60				66261017306	
	S/C	F	4-6	22,000	60				66261014906	
2 x 3/16	A/O	M	2-3	22,000	60			66254428236		
2 x 1/4	A/O	C	7-9	22,000	60					66261054187
	A/O	M	1	22,100	25	66254497067	66254497070			
	A/O	M	2-3	22,000	60			66254428237		66261054183
	A/O	M	4-6	22,000	60			66254413660		66261054185
	A/O	M	7-9	22,000	60			66254433510		66261054186
	S/C	F	2-3	22,000	60					66261054182
	S/C	F	4-6	22,000	60					66261054184
3 x 1/8	A/O	C	7-9	15,000	40				66261014922	
	A/O	M	2-3	15,000	40				66261014898	
	A/O	M	4-6	15,000	40			66261093556	66261014912	66261054191
	A/O	M	7-9	15,000	40			66261090909	66261014936	
	A/O	F	2-3	15,000	40					66261054188
	A/O	F	4	15,000	40				66261015419	66261054189
	A/O	F	6	15,000	40					66261054190
3 x 3/16	A/O	M	7-9	15,000	40			66254428239		
3 x 1/4	A/O	C	7-9	15,000	40					66261054198*
	A/O	M	1	18,100	25	66254497068	66254497069			
	A/O	M	2-3	15,000	40			66254428238		66261054193*
	A/O	M	4-6	15,000	40			66254413661		66261054196*
	A/O	M	7-9	15,000	40			66254406395		66261054197*
	A/O	F	2-3	15,000	40					66261054192*
	A/O	F	4-6	15,000	40					66261054194*
	S/C	F	2	15,000	40				66261014890	
	S/C	F	3	15,000	40				66261016005	
	S/C	F	4-6	15,000	40					66261054195*

* MERIT DEBURR/BLEND STD. PKG. = 20 DISCS NS = NON-STOCK

Refer to the end of this section for a list of quick-change back-up pads.



FEATURED PRODUCTS AND AVAILABILITY

Surface Preparation Stars



- The perfect item for I.D. work
- Their shape penetrates the I.D. and polishes or cleans the surface without disturbing any tolerances
- Attach their 1/4-20 eyelets to Merit's MM20-4 mandrel. Part No. 08834183164 (See description at end of Overlap Slotted Disc Section.)

TIER:	GOOD
BRAND:	Merit
TRADENAME:	AG
ABRASIVE:	A/O
ATTACHMENT:	1/4-20

SIZE (D X EYELET)	GRIT	STD. PKG.	PART NO.
1-1/2" x 1/4-20	C	100	08834185923
	M		08834185924
	VF		08834185925
2" x 1/4-20	C	100	08834185926
	M		08834185927
	VF		08834485928
3" x 1/4-20	C	100	08834185929
	M		08834185678
	VF		08834185931
4" x 1/4-20	C	100	08834185932
	M		08834185933
	VF		08834185934

FEATURED PRODUCTS AND AVAILABILITY

Surface Preparation Discs



Norton Surface Preparation Discs

Norton STE-CS

- Aggressive, very sharp abrasive, closed structure; work best on harder materials, and low- and high-force applications

Norton STE-VS

- Slightly open structure, firm backing; great multi-purpose discs; work well on a variety of materials

Norton STE

- More open structure, flexible backing; excellent on soft materials and low-force applications

TIER:	BEST	BEST	BETTER	BETTER	GOOD	GOOD
BRAND:	Norton	Norton	Norton	Norton	Norton	Norton
TRADENAME:	STE-CS	STE-CS	STE-VS	STE-VS	STE	STE
ABRASIVE:	A/O	A/O	A/O	A/O	A/O	A/O
ATTACHMENT:	TS (Type II)	TR (Type III)	TS (Type II)	TR (Type III)	TS (Type II)	TR (Type III)

SIZE (D)	GRIT	STD. PKG.	PART NO.	PART NO.	PART NO.	PART NO.	PART NO.	PART NO.
2"	XC	50	66261017819	66261016373				
	C				66261004439	66261004437	66261009183	66261009191•
	M		66261017528	66261016763	66261004449	66261004447	66261009182	66261009190•
	VF				66261004459	66261004457	66261009181	66261009189•
3"	XC	25	66261017818	66261016994				
	C				66261004440	66261004438	66261009186	66261009194
	M		66261017817	66261016995	66261004450	66261004448	66261009185	66261009193
	VF				66261004460	66261004458	66261009184	66261009192
4"	C	25			66261055349	66261008822		
	M				66261055350	66261008821		
	VF				66261008820			

• PACKAGING STANDARDS: 2" STE TR DISCS STD. PKG. = 25
 REFER TO THE END OF THIS SECTION FOR A LIST OF QUICK-CHANGE BACK-UP PADS

Refer to the end of this section for a list of quick-change back-up pads.





Surface Preparation Discs



Merit AG Surface Preparation Discs

AG

- Aggressive, very sharp abrasive, closed structure; work best on harder materials, and low- and high-force applications

TIER:	BEST	BEST	BEST
BRAND:	Merit	Merit	Merit
TRADENAME:	AG	AG	AG
ABRASIVE:	A/O	A/O	A/O
ATTACHMENT:	TS (Type II) 	TR (Type III) 	5/8-11 

SIZE (D)	GRADE	STD. PKG.	PART NO.	PART NO.	PART NO.
2"	C	50	08834167821	08834167825	
	M		08834167822	08834167826	
3"	C	25	08834167823	08834167827	
	M		08834167824	08834167828	
5"	C	50			08834164631
	M				08834168802
7"	C	25			6995735012
	M				66261039943









Merit GD & XC Surface Preparation Discs

GD

- Slightly open structure, firm backing; great multi-purpose discs; work well on a variety of materials

XC

- More open structure, flexible backing; excellent on soft materials and low-force applications

TIER:	BETTER	BETTER	BETTER	GOOD	GOOD	GOOD	GOOD
BRAND:	Merit	Merit	Merit	Merit	Merit	Merit	Merit
TRADENAME:	GD	GD	GD	XC	XC	XC	XC
ABRASIVE:	A/O	A/O	A/O	A/O	A/O	A/O	A/O
ATTACHMENT:	TS (Type II) 	TR (Type III) 	TP (Type I) 	TS (Type II) 	TR (Type III) 	TP (Type I) 	5/8-11 

SIZE (D)	GRIT	STD. PKG.	PART NO.	PART NO.	PART NO.	PART NO.	PART NO.	PART NO.
3/4"	C	100	08834163637	08834166231	08834163845	08834166239	08834166242	08834166236
	M		08834163638	08834166212	08834163846	08834166238	08834166241	08834166235
	VF		08834163639	08834166211	08834163847	08834166237	08834166240	08834166234
1"	C	100	08834163640	08834163850	08834166201	08834166474	08834166248	08834161710
	M		08834163641	08834163851	08834166200	08834166475	08834167368	08834166246
	VF		08834163642	08834163852	08834166199	08834166476	08834160754	08834166243
1-1/2"	C	100	08834164736	08834163540	08834163048	08834166407	08834166366	08834166334
	M		08834163590	08834163515	08834163049	08834166408	08834166380	08834166335
	VF		08834163589	08834163516	08834163050	08834166409	08834166367	08834166336
2"	C	50	08834162906	08834162912	08834163039	08834166287	08834166289	08834166271
	M		08834162907	08834162913	08834163040	08834166288	08834166290	08834166272
	VF		08834162908	08834162914	08834163041	08834166317	08834166318	08834166273
3"	C	25	08834162909	08834162915	08834163045	08834166319	08834166322	08834166275
	M		08834162910	08834162916	08834163046	08834166320	08834166291	08834166276
	VF		08834162911	08834162917	08834163047	08834166321	08834166323	08834166277
4"	C	25	08834166445	08834166448	08834166442	08834166388	08834166327	08834166298
	M		08834166444	08834166447	08834166441	08834166389	08834166328	08834166299
	VF		08834166443	08834166446	08834166440	08834166390	08834166329	08834166300
5"	C	50						08834166411
	M							08834166412
	VF							08834166413
7"	C	25						08834166414
	M							08834166415
	F							08834166416

Refer to the end of this section for a list of quick-change back-up pads.







FEATURED PRODUCTS AND AVAILABILITY

Buffing/Polishing Discs



Merit Buffing Discs

- Tough, yet conformable, high-strength discs are smear-proof and resist tearing on burrs and sharp edges
- Designed for light removal of paint or rust without affecting the base product

TIER:	BETTER	BETTER	GOOD	GOOD	GOOD
BRAND:	Merit	Merit	Merit	Merit	Merit
TRADENAME:	HIGH-STRENGTH	HIGH-STRENGTH	BUFFING	BUFFING	BUFFING
ABRASIVE:	A/O	A/O	A/O	A/O	A/O
ATTACHMENT:	TS (Type II) 	TR (Type III) 	TS (Type II) 	TR (Type III) 	TP (Type I) 

SIZE (D)	GRIT	STD. PKG.	PART NO.	PART NO.	PART NO.	PART NO.	PART NO.
1-1/2"	C	100			08834166391	08834161647	08834166294
	M				08834166392	08834166368	08834166292
	F				08834166393	08834166369	08834166332
	VF				08834166406	08834166417	08834166333
2"	C	50	08834164244	08834164064	08834166394	08834161649	08834161627
	M				08834166395	08834166303	08834166280
	F				08834166396	08834166304	08834166281
	VF				08834164245	08834163987	08834166305
3"	C	25	08834164252	08834164065	08834166397	08834161651	08834166293
	M				08834166398	08834166308	08834166284
	F				08834166399	08834166309	08834166285
	VF				08834164255	08834163559	08834166310
4"	C	25			08834166400	08834161654	08834161652
	M				08834166401	08834166314	08834166295
	F				08834166402	08834166315	08834166296
	VF				08834166404	08834166316	08834166297



Merit Felt Polishing Discs

- Made from a white, non-abrasive, felt material for final polishing applications
- Can be used with or without polishing compounds

TIER:	GOOD
BRAND:	Merit
TRADENAME:	FELT POLISHING
ABRASIVE:	Non-Abrasive
ATTACHMENT:	TR (Type III) 

SIZE (D)	STD. PKG.	PART NO.
2"	50	08834164407
3"	25	08834164408

Quick-Change Back-up Pads

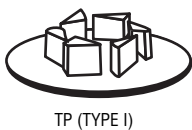
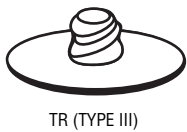
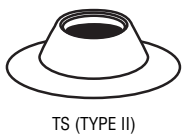

- Hard density pads are for aggressive cutting action
- Medium density pads are for all-purpose applications
- Soft density pads are used for contours and fine finishing work

Refer to the end of the Coated Abrasive Quick-Change Discs section for a complete list of back-up pads and mandrels.

DIAMETER	MAX. RPM	DENSITY	TS (TYPE II)	TR (TYPE III)	TP (TYPE I)
QUICK-CHANGE BACK-UP PADS					
9/16"	40,000	Medium	66261054014		66261054013
3/4"	40,000	Medium	08834164206	08834164038	08834164001
1"	40,000	Medium	08834164651	08834164037	08834164002
1-1/2"	30,000	Hard	08834164622	08834164640	08834163996
		Medium	08834164146	08834161174	08834164003
2"	30,000	Hard	08834164624	08834164643	08834163997
		Medium	08834164198	08834164922	08834164004
		Soft	08834161625	08834164641	08834163949
3"	20,000	Hard	08834161626	08834164036	08834163998
		Medium	08834164113	08834164949	08834164005
		Soft	08834164626	08834164644	08834163948
4"	15,000	Medium	08834164135	08834164655	08834164006

ALL QUICK-CHANGE BACK-UP PADS HAVE A 1/4" DIAMETER SHANK. STD. PKG. = 1



FEATURED PRODUCTS AND AVAILABILITY

Non-Woven Hook and Loop Discs



STE-VS HOOK AND LOOP DISCS

BETTER CHOICE FOR MULTI-PURPOSE APPLICATIONS

FEATURES

- Slightly open structure
- High abrasive content
- Firm backing

BENEFITS

- Resists loading and chunking
- Continuous cut rate on soft (e.g. aluminum) and hard materials (e.g. steels and nickel alloys)
- Low stretch

	TIER:		BETTER	GOOD	
	BRAND:		Norton	Merit	
	TRADENAME:		STE-VS	GD	
	ABRASIVE:		A/O	A/O	
	ATTACHMENT:		Hook and Loop	Hook and Loop	
SIZE (D)	ABRASIVE	GRIT	STD. PKG.	PART NO.	PART NO.
2" Blank	A/O	C	80	66261004431	05539562621
	A/O	M		66261004441	05539562620
	A/O	VF		66261004451	05539562619
3" Blank	A/O	C	60	66261004432	05539562624
	A/O	M		66261004442	05539562623
	A/O	VF		66261004452	05539562622
4" Blank	A/O	C	40	66261004433	05539512515
	A/O	M		66261004443	05539512514
	A/O	VF		66261004453	05539512513
4-1/2" Blank	A/O	C	40	66261004434	05539520420
	A/O	M		66261004444	05539520419
	A/O	VF		66261004454	05539520418
5" Blank	A/O	C	40	66261004435	05539512519
	A/O	M		66261004445	05539512518
	A/O	VF		66261004455	05539512517
6" Blank	A/O	C	30	66261006910	05539512522
	A/O	M		66261006911	05539512521
	A/O	VF		66261006912	05539512520
7" Blank	A/O	C	25	66261004436	05539512525
	A/O	M		66261004446	05539512524
	A/O	VF		66261004456	05539512523
8" Blank	A/O	C	20	66261006913	05539562627
	A/O	M		66261006914	05539562626
	A/O	VF		66261006915	05539562625



PAD DIAMETER	SPINDLE OR HOLE SIZE	MAX. RPM	3M EQUIVALENT	STD. PKG.	PART NO.
BACK-UP PADS FOR HOOK AND LOOP DISCS					
2	1/4 Steel Shank	23,000	922	5	66261059352
3	1/4 Steel Shank	20,000	923	5	66261059354
4	1/4 Steel Shank	18,000	924	5	66261059356
	1/2-13	13,000	914	5	66261059303
	5/8-11	13,000	914	5	66261059304
	M10 x 1.250	13,000		5	66261059305
4-1/2	5/8-11	10,000	9145	5	66261006948
5	5/16-24 Male	10,000	905	5	66261059360
	3/8-24 Male	10,000	905	5	66261059308
	5/8-11	10,000	915	5	66261059310
6	5/8-11	8,000	916	5	66261059312
7	5/8-11	6,000	917	5	66261059368
8	5/8-11	4,500	918	5	66261059372



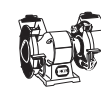

FEATURED PRODUCTS AND AVAILABILITY

Non-Woven High Strength Discs



HIGH STRENGTH AND FASTCUT DISCS
BETTER CHOICE FOR LIGHT DEBURRING AND FINISHING

FEATURES

- Firm, durable web
- Tough, yet conformable
- Strong, smear-proof resin binders

BENEFITS

- High resistance to tearing on burrs and sharp edges
- Can be “ganged” together and used as a wheel
- Produce light satin finishes

- Applications include rust/oxide or coating removal, pipe ID and OD polishing, casting cleaning, highlighting (antiquing), contaminant removal, removal of handling marks, gasket removal, cleaning and blending of surface imperfections, prepping prior to soldering, removal of filling materials, cleaning angles and odd shapes

TIER:	BETTER
BRAND:	Norton
TRADENAME:	HIGH STRENGTH
ABRASIVE:	Aluminum Oxide

SIZE (D X H)	ABRASIVE	GRIT	MAX. RPM	STD. PKG.	PART NO.
6 x 1/4	A/O	VF	4,000	70	66261007628
6 x 1/2	A/O	M	4,000	70	66261005073
	A/O	VF			66261004980
8 x 1/2	A/O	M	3,000	50	66261005491
	A/O	VF			66261004506
12 x 1-1/4	A/O	VF	1,900	25	66261008723



FITS HOLE	FOR DISC WIDTH	FOR DISC DIAMETER	SHANK DIAMETER	OVERALL LENGTH	WASHER DIAMETER	STD. PKG.	PART NO.
MANDREL ASSEMBLIES FOR USING DISCS ON EDGE							
1/4"	1/2" (Standard)	up to 6"	1/4"	2-1/2"	1-1/2"	1	66261009502
1/2"	1/2" (Standard)	Up to 8"	1/4"	3-1/8"	2-1/4"	1	66261059420

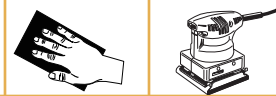

CATEGORY DEFINITION

Surface finishing hand pads and rolls are made of a non-woven nylon web impregnated with abrasive grain and resin bond.

- APPLICATIONS:** Light- to heavy-duty cleaning, deburring, blending, polishing, and finishing of metal, wood, composite, plastics, stone, solid surface and painted surfaces.
- ABRASIVE GRAIN:** Aluminum Oxide, Silicon Carbide
- GRIT RANGE:** Coarse (C), Medium (M), Fine (F), Very Fine (VF), Ultra Fine (UF), Micro Fine (MF), Non-Abrasive (-)
- HAND PAD FEATURES:**
- Flexible; conform to work surface
 - Gentle action easily removes flashing or burrs without affecting dimension of workpiece
 - Non-loading; constant supply of new cutting edges
 - Non-rusting; no workpiece contamination
 - Resilient construction; long life, increased productivity; solvent resistant; waterproof
- SPONGE PAD FEATURES:**
- Non-woven material is laminated to a long-lasting sponge for the convenience of 2 pads in one
 - Superior replacement for steel wool
- ROLL FEATURES:**
- Economical alternative to cut pads
 - Can be cut to specific sizes

APPLICATION/GRIT RECOMMENDATION GUIDE

	← MORE AGGRESSIVE, ROUGHER FINISH					LESS AGGRESSIVE, FINER FINISH →				
PRODUCT #:	#181	#740	#746	#644	#747	#796	#635	#748	#914	#456
COLOR:	(BLUE)	(DARK TAN)	(GRAY)	(MAROON)	(MAROON)	(GREEN)	(GRAY)	(GRAY)	(GOLD)	(WHITE)
DESCRIPTION:	STRIPPING	HEAVY DUTY	BLENDING	GP - FINE	GP PLUS - VERY FINE	SCOURING	CLEAN & FINISH	FINAL SHINE	CLEAR BLEND PREP	CLEANING
ABRASIVE:	AO	AO	SC	AO	AO	AO	SC	SC	AO	Non-Abrasive
GRIT SIZE:	Coarse 50 - 80	Medium 100 - 150	Medium 100 - 150	Fine 180 - 220	Very Fine 240 - 360	Very Fine 240 - 360	Ultra Fine 400 - 600	Micro Fine 800 - 1200	Micro Fine 800 - 1200	Non-Abrasive - - - -
STEEL WOOL EQUIVALENT:	2 Coarse	1 Medium	1 Medium	N/A	0 Fine	0 Fine	00 VF	000 EF	000 EF	0000 SF
APPLICATION:	<ul style="list-style-type: none"> • Extra heavy stripping and cleaning - Coatings - Paint - Corrosion - Rust 	<ul style="list-style-type: none"> • Heavy-duty removal - rust - oxidation • Deburring 	<ul style="list-style-type: none"> • Blending and deburring - welds - aluminum - dies 	<ul style="list-style-type: none"> • Cleaning and deburring - machinery - metal parts - plastic - solid surface - stone 	<ul style="list-style-type: none"> • Light cleaning, deburring and finishing - machinery - metal parts - plastic - solid surface - stone 	<ul style="list-style-type: none"> • Removing stains, marks, rust, corrosion or oxidation from stainless equipment • Light cleaning of metal surfaces 	<ul style="list-style-type: none"> • Light cleaning and finishing of most surfaces - steel, aluminum - denibbing plastic - scuffing acrylics 	<ul style="list-style-type: none"> • Final finishing - final rub on wood - final blend metal - final finish plastics and acrylics 	<ul style="list-style-type: none"> • Scuffing prior to clear coat blending • Sanding base coats without removing the coat • Polishing, blemish repair and finishing all materials 	<ul style="list-style-type: none"> • Scratch-free cleaning - stainless steel - fiberglass - stone - solid surface - ceramic - copper / chrome • Wood - highlighting - rubbing

CROSS REFERENCE GUIDE

	← COARSER				FINER →					
Norton/Merit	#181	#740	#746	#644	#747	#796	#635	#748	#914	#456
3M	-	7440	7446	6444	7447/8447 Production Hand Pad	96	6448	7448	-	7445
Camel	-	Tan	-	-	Maroon	Green	-	Grey	-	White
Mirka	-	-	-	-	Maroon/Red VF	-	-	-	-	-
Sait	-	Brown	-	-	Maroon	Green	-	Gray	-	-
SIA	-	6912 Brown	6712 Grey	-	6912 Maroon	6312 Green	-	-	-	-
Standard	-	HD-Tan AO	-	-	GP-Maroon VF	Green-AO	HP-VF	UF Gray	-	Cleaning White



AVAILABILITY						TIER:	BETTER	GOOD	GOOD
						BRAND:	Norton	Norton	Merit
SIZE (W X L)	COLOR	DESCRIPTION	ABRASIVE	GRIT SIZE	STD. PKG.		PART NO.	PART NO.	PART NO.
HAND PADS									
6 x 9	Blue	181 Stripping Pad	A/O	C	20			66254494732	
	Dark Tan	740 Heavy-Duty Pad	A/O	Med	20			66261074000	08834193462
	Gray	746 Blending Pad	S/C	Med	20			66261074600	
	Maroon	644 General Purpose Fine Pad	A/O	F	20			66261018286	
	Maroon	777 General Purpose Very Fine Pad	A/O	VF	20			66261077700	08834193463
	Maroon	747 General Purpose Plus Pad	A/O	VF	20		66261074700		08834196204
	Maroon	747 General Purpose Plus Perforated Pad	A/O	VF	20		66261084700		
	Green	796 Scouring Pad	A/O	VF	20			66261079600	08834193497
	Lt. Green	696 Food Pro Pad	A/O	VF	20			66261069600	
	Gray	851 General Cleaning Pad	S/C	VF	20			66261085100	
	Gray	635 Clean & Finish Pad	S/C	UF	20			66261063500	
	Gray	748 Final Shine Pad	S/C	MF	20			66261074800	08834196196
	Gold	914 Clear Blend Prep Pad	A/O	MF	20			66261195914	
	White	456 Cleaning Pad	None	-	20			66261045600	08834193270
HAND PAD HOLDER									
3-1/4 x 5-1/2	N/A	Hand Pad Holder			10			66261047583	08834190748
ROLLS									
2" x 30 Ft.	Dark Tan	740 Heavy-Duty Roll	A/O	M	10			66254494550	
	Maroon	777 General Purpose Roll	A/O	VF	10			66261041679	
	Gray	635 Clean & Finish Roll	S/C	UF	10			66261002982	
4" x 30 Ft.	Maroon	High Strength Roll	A/O	M	3		66261006358		
	Dark Tan	740 Heavy-Duty Roll	A/O	M	3			66261010081	
	Maroon	644 General Purpose Fine Roll	A/O	F	4			66261058364	05539511952
	Maroon	777 General Purpose Very Fine Roll	A/O	VF	4		66261006373		05539526809
	Maroon	747 General Purpose Plus Roll	A/O	VF	4		66261051701		05539562608
	Green	796 Scouring Roll	A/O	VF	5				05539562607
	Gray	851 General Cleaning Roll	S/C	VF	3			66261058360	05539515708
	Gray	635 Clean & Finish Roll	S/C	UF	5			66261058357	05539512500
	Gray	748 Final Shine Roll	S/C	MF	5				05539562609
	White	456 Cleaning Roll	None	-	3			66261052235	05539512839
6" x 30 Ft.	Maroon	High Strength Roll	A/O	M	2		66261005182		05539527176
	Maroon	747 General Purpose Plus Roll	A/O	VF	3		66261016430		05539512505
	Maroon	777 General Purpose Very Fine Roll	A/O	VF	3		66261004281		05539526424
	Gray	851 General Cleaning Roll	S/C	VF	3			66261058377	05539562610
	Gray	635 Clean & Finish Roll	S/C	UF	3				05539512503
SCOURING PADS/SPONGES									
3-1/4 x 6-1/4 x 3/4	Green/Yellow	893 Scour-N-Sponge Pad	A/O	VF	40			66261059403	
3-1/4 x 6-1/4 x 3/4	White/Yellow	875 Clean-N-Sponge Pad	None	-	40			66261059402	



Handy Roll Assortment Pack



- Part No. 66261008108
- Non-woven rolls may be cut for use in hand sanding applications
- Convenient dispenser box containing three 2" x 15 foot long rolls, 1 each of:
644 General Purpose Fine
747 General Purpose Plus
748 Fine Shine



Hand Pad Test Kit

- Part No. 66254494733
- Non-woven pads are used in applications ranging from stripping and blending to cleaning and polishing
- Hand Pad Test Kit provides one of each of the 14 different materials along with the recommendation guide to help determine which pads you need for all your applications

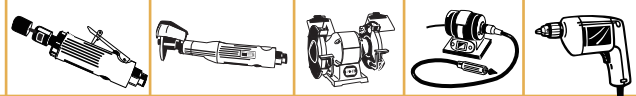

CATEGORY DEFINITION

Made from non-woven synthetic fiber mesh, which is impregnated with abrasives and bound with resins, non-woven wheels are designed to create desired surface finish where little or no stock removal is required. The industry's broadest offer is available for light stock removal, deburring, blending, finishing and polishing. Non woven wheels have an open mesh construction that is waterproof, washable, conformable and non-loading.

- APPLICATIONS:** Clean and remove imperfections on metal surfaces, clean built-up residue, deburr or finish a variety of surfaces, blend weld seams or create decorative finishes.
Non-woven surface finishing products have excellent versatility.
- ABRASIVE GRAIN:** Aluminum Oxide, Silicon Carbide
- GRIT RANGE:** Extra Coarse (XC), Coarse (C), Medium (M), Very Fine (VF),

APPLICATION/GRIT RECOMMENDATION GUIDE

	← MOST AGGRESSIVE → LEAST AGGRESSIVE →						
	RAPID STRIP	VORTEX & NEX UNIFIED WHEELS	SERIES 4000 & 1000 CONVOLUTE WHEELS	METAL FINISHING CONVOLUTE WHEELS	CLEAN & FINISH WHEELS	LIGHT FINISHING CONVOLUTE WHEELS	NON-WOVEN / INTERLEAF FLAP WHEELS
SCALE REMOVAL	BEST CHOICE						
STOCK REMOVAL	BEST CHOICE						
HEAVY DEBURRING	BEST CHOICE						
DECORATIVE FINISHING	BEST CHOICE						
BLENDING	BEST CHOICE						
CLEANING	BEST CHOICE						
LIGHT DEBURRING	BEST CHOICE						
LIGHT FINISHING	BEST CHOICE						
POLISHING	BEST CHOICE						
BUFFING	BEST CHOICE						

SURFACE FINISH VARIABLES

Changes in any one of many factors can affect the surface finish on the workpiece. This chart shows the effect on surface finish by changes in single factors of product specifications. Arrows have been used to signify the trend direction. The arrow length does not signify that the effect of each factor is equal.

Variable Factor	Rough Finish High Rms Reading	Smooth Surface Lower Rms Reading
1. Wheel Speed	Slow ←	Fast →
2. Feed Speed	Faster (Long Scratch) ←	Slower (Short Scratch) →
3. Oscillation	No Oscillation ←	Oscillation →
4. Lubricants	Dry ←	Water ← Soluble Oil ← Compounds → Straight Oil →

NON-WOVEN MARKING SYSTEM

ABRASIVE	S/C					A/O
	SHARPER, FINER/BRIGHTER SCRATCH PATTERN					MORE DURABLE, LONGER LASTING, POLISHED FINISH
GRIT SIZE	XC (24-36)	C (50-80)	M (100-150)	F (180-220)	VF (240-360)	
	FASTER, AGGRESSIVE CUT, ROUGHER FINISH			REDUCED CUT RATE, FINER FINISH		
DENSITY	2					9
	SOFT, OPEN, CONFORMABLE, LESS BURNING/LOADING			HARDER, MORE DURABLE, FASTER CUTTING, BETTER FINISH		

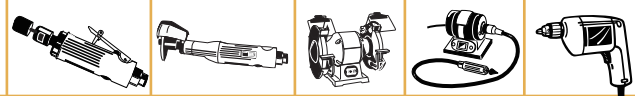

CROSS REFERENCE GUIDE

	STRIPPING	HEAVY/LIGHT DEBURRING			LIGHT DEBURRING/BLENDING/POLISHING			CLEANING/FINISHING	
NORTON	GOOD Rapid Strip	BEST Vortex Debur & Blend	BETTER NEX Deburring & Blending	BEST Series 4000	BETTER Series 1000	BEST Light Finishing	BEST Metal Finishing	GOOD Clean & Finish	GOOD Non-Woven / Interleaf Flap Wheels
3M	Clean Strip	Cut & Polish Unitized	EXL Unitized	EX2 & EX3	EXL Deburring	Light Deburring	Metal Finishing	Multi Finishing	Finishing Flap Brush
Standard	Britestrip	800 & 900 Series Unitized	500 - 700 Series Unitized	GP Plus	Deburring Convolute	LDW	Metal Finishing	Multi Finishing	Buff & Blend Flap Brush



Surface Stripping Wheels

- Surface Stripping material provides a unique combination of aggressive performance, long life and improved finish. It is ideal for removing coatings on a variety of substrates, such as wood, metal and plastics.
- Incorporated with extruded nylon fibers, flexible resin technology and extra-coarse silicon carbide mineral that provide aggressive performance while outperforming traditional coated abrasives. They leave a thoroughly cleaned surface that ensures excellent adhesion for subsequent processes such as coating, painting and soldering.

AVAILABILITY

TIER: **GOOD**
TRADENAME: **SURFACE STRIPPING WHEELS**

SIZE	MAX. RPM	STD. PKG.	PART NO.
ARBOR HOLE			
4 x 1/4	8,000	25	66261008008
4 x 1/2	8,000	25	66261007916
6 x 1/2	5,500	15	66261008051
8 x 1/2	3,000	24	08834191432
MANDREL-MOUNTED			
4 x 1/2 x 1/4 sk.	8,000	5	08834120974
4 x 1 x 1/4 sk.	8,000	5	08834120973

Deburring and Blending Unified Wheels

- Designed for maintenance operations needing an efficient and cost-effective method of deburring, polishing, cleaning or finishing metals and composites. Easily preformed for use on a wide variety of shapes / contours. Hold shape well; less wheel dressing. Non-metallic so no contamination of workpiece. Uniform construction maintains part tolerance; prevents cutting or gouging.



NORTON VORTEX UNIFIED WHEELS

BEST CHOICE FOR LIGHT WELD BEAD AND WELD SPLATTER REMOVAL, HEAVY DEBURRING AND FINISHING APPLICATIONS

FEATURES

- High-performance engineered grain and improved resin bond system
- Thick nylon web
- Controlled porosity

BENEFITS

- Aggressive, fast, stock removal, reduced cycle times, and increased part quality
- 2X longer life and faster finishing – with minimal shedding
- Cool cutting and improved cut rate

AVAILABILITY

TIER: **BEST**
TRADENAME: **VORTEX DEBURRING AND BLENDING UNIFIED WHEELS**

SIZE (D X T X H)	ABRASIVE	GRIT SIZE	STD. PKG.	MAX. RPM	3 DENSITY PART NO.	MAX. RPM	5 DENSITY PART NO.	MAX. RPM	7 DENSITY PART NO.	MAX. RPM	9 DENSITY PART NO.
2 x 1/8 x 1/8	A/O	M	60			22,000	66254425657	20,000	66254410849		
2 x 1/8 x 1/4	A/O	M	60			22,000	66254406346	22,000	66261191446		
2 x 1/4 x 1/4	A/O	M	60	18,000	66254428456	22,000	66254433504	22,000	66261080270		
2 x 1 x 1/4	A/O	M	15					22,000	66261080269		
3 x 1/8 x 1/4	A/O	M	40			18,000	66261093448	18,000	66261191445		
3 x 1/8 x 3/8	A/O	M	40			18,000	66254433503	18,000	66254401131		
3 x 1/4 x 1/4	A/O	M	40	12,000	66254428454	18,000	66254414832	18,000	66261199696		
3 x 1/4 x 3/8	A/O	M	40	12,000	66254433505	12,000	66254433506	18,000	66261199697		
3 x 1/2 x 1/4	A/O	M	20			18,000	66254432925	18,000	66261080267	18,000	66254433507
3 x 1/2 x 3/8	A/O	M	20			18,000	66254433508	18,000	66261080266	18,000	66254420696

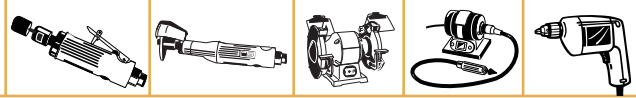

Deburring and Blending Unified Wheels CONTINUED



NEX UNIFIED WHEELS
 BETTER CHOICE FOR LIGHT DEBURRING AND BLENDING

FEATURES

- Uniform construction
- Smear-resistant formula

BENEFITS

- Extra long life
- Excellent, consistent, smear-free finishes

AVAILABILITY

TIER:

BETTER

TRADENAME:

NEX DEBURRING AND BLENDING UNIFIED WHEELS

SIZE (D X T X H)	ABRASIVE	GRIT	MAX. RPM	STD. PKG.	2 DENSITY PART NO.	3 DENSITY PART NO.	4 DENSITY PART NO.	6 DENSITY PART NO.	7 DENSITY PART NO.	8 DENSITY PART NO.
1 x 1 x 3/16	A/O	C	30,000	50	66261014891			66261014908		66261014915
	A/O	M	18,000							
	A/O	M	30,000							
	S/C	F	18,000							
	S/C	F	30,000							
66261014883			66261014904		66261014924					
2 x 1/8 x 1/4	A/O	M	22,000	60						66261014927
2 x 1/4 x 1/4	A/O	C	22,000	60	66261014892			66261014901		66261014916
	A/O	M	18,000							
	A/O	M	22,000							
	A/O	F	22,000							
	S/C	M	22,000							
	S/C	F	18,000							
66261014884					66261014964					
2 x 1/2 x 1/4	A/O	M	22,000	30						66261014925
3 x 1/8 x 1/4	A/O	M	18,000	40						66261014934
3 x 1/4 x 1/4	A/O	C	18,000	40	66261014894			66261015565	66261014909	66261014930
	A/O	M	12,000							
	A/O	M	18,000							
	A/O	F	18,000							
	S/C	M	18,000							
	S/C	M	18,000							
	S/C	F	12,000							
66261014886	66261016392			66261014937						
3 x 1/4 x 3/8	A/O	C	18,000	40	66261014895			66261014899	66261014910	66261014920
	A/O	M	12,000							
	A/O	M	18,000							
	A/O	F	12,000							
	S/C	M	18,000							
	S/C	F	12,000							
	S/C	F	12,000							
	S/C	F	18,000							
66261014887	66261016006			66261014933						
66261014905				66261014965						
3 x 1/2 x 1/4	A/O	C	18,000	20	66261014893			66261014928		66261014917
	A/O	M	12,000							
	A/O	M	18,000							
	S/C	F	12,000							
	66261014885									
3 x 1/2 x 3/8	A/O	C	18,000	20					66261014913	66261014918
	A/O	M	18,000							
	S/C	XC	14,000							
66261014929										
3 x 1 x 3/8	S/C	XC	14,000	10						66261014914
6 x 1/2 x 1	A/O	M	7,500	4						66261014931
6 x 1 x 1	A/O	M	5,000	2	66261014896					
	S/C	F	5,000		66261014888					

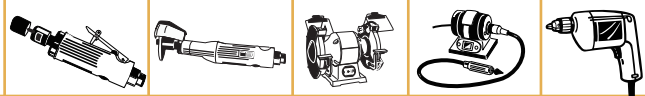

Deburring and Blending Unified Wheels CONTINUED

AVAILABILITY

TIER:

GOOD

TRADENAME:

**GENERAL DUTY
UNIFIED WHEELS**

SIZE (D X T X H)	ABRASIVE	GRIT	DENSITY	MAX. RPM	STD. PKG.	PART NO.
1 x 1 x 3/16	A/O	C	8	15,000	50	66261000938
2 x 1/4 x 1/4	A/O	C	8	11,000	60	66261052275
2 x 1/2 x 1/4	A/O	F	4	11,000	40	66261058764
3 x 1/4 x 1/4	A/O	C	8	8,000	40	66261052276
	A/O	F	4	8,000		66261058816
	S/C	F	4	8,000		66261000745
3 x 1/2 x 1/4	A/O	F	4	8,000	20	66261054046
	S/C	F	4	8,000		66261054048
3 x 3/4 x 1/4	A/O	F	4	8,000	20	66261058769
	S/C	M	4	8,000		66261058773
	S/C	F	4	8,000		66261058771
6 x 1/2 x 1/2	S/C	M	4	4,800	8	66261058779
6 x 1 x 1/2	S/C	M	4	4,800	4	66261058792
	S/C	F	4	4,800		66261058790
6 x 1 x 1	S/C	F	4	4,800	4	66261058797

Mandrels for Unified Wheels

FITS WHEEL CENTER HOLE	FOR WHEEL WIDTH	FOR WHEEL DIAMETER	SHANK DIAMETER	OVERALL LENGTH	WASHER DIAMETER	3M EQUIVALENT	STD. PKG.	PART NO.
MANDREL ASSEMBLIES FOR UNIFIED WHEELS AND DISCS ON EDGE								
1/8" – 3/16"	Up to 1/2"	Up to 2"	1/8"	1-3/4"	7/16"	931	1	66261009849
3/16"	1/8" – 1/2"	1" – 2"	1/4"	2"	7/16"	994	1	66261009852
1/4" – 5/16"	Up to 1/2"	Up to 2"	1/4"	2"	5/8"	932	1	66261015146
1/4" – 5/16"	Up to 1"	Up to 2"	1/4"	2-1/2"	5/8"	932	1	66261059422
	Up to 1"	2" – 3"	1/4"	2-1/2"	1"	933	1	66261059421
3/8"	Up to 1/2"	2" – 4"	1/4"	2-1/2"	1"	990	1	66261009851
1/2"	Up to 1"	3" – 6"	1/4"	3-1/8"	1-5/8"	934	1	66261009850

SHANK LENGTH	SHANK DIAMETER	FOR CENTER HOLE	USE WITH UNIFIED WHEEL	3M EQUIVALENT	STD. PKG.	PART NO.
THREADED MANDREL FOR UNIFIED WHEELS						
1-3/4"	1/4"	3/16	1 x 1 x 3/16	948	5	66261047584



MANDREL ASSEMBLY 66261059421 FOR UNIFIED WHEELS



MANDREL ASSEMBLY 66261059422 FOR UNIFIED WHEELS



THREADED MANDREL 66261047584 FOR UNIFIED WHEELS



Convolute Wheels

- Formed by wrapping and bonding web material impregnated with abrasive grain and resin around a center core. Convolute wheels offer a wide range of uses from burr removal to cleaning rust and oxides.
- Burr and flashing removal
- Surface roughness reduction
- Blending weld areas on stainless steel
- Blending scratch patterns
- Weld polishing
- Removing rust and oxides
- Applying decorative finishes including antique patterns

FEATURED PRODUCTS



SERIES 4000 CONVOLUTE WHEELS BEST CHOICE FOR HEAVY DEBURRING APPLICATIONS

FEATURES

- Advanced resin bond system
- High quality synthetic web

BENEFITS

- Free cutting
- Use both wet and dry
- Long life for heavy deburring, edge breaking and removing parting lines on exotic metals

AVAILABILITY

TIER: **BEST**

TRADENAME: **SERIES 4000 CONVOLUTE WHEELS**

SIZE (D X T X H)	ABRASIVE	GRIT	MAX. RPM	STD. PKG.	8 DENSITY PART NO.	9 DENSITY PART NO.
SERIES 4000 CONVOLUTE WHEELS						
6 x 1/2 x 1	S/C	F	6,000	4		66261004021
6 x 1 x 1	A/O	M	6,000	3	66261004208	66261004141
	S/C	F			66261004142	
8 x 1 x 3	A/O	M	4,500	3	66261004165	66261004135
	S/C	F			66261004123	
12 x 1 x 5	S/C	F	3,000	2	66261004284	66261004148
12 x 2 x 5	S/C	F	3,000	1		66261004011

TECHtip

- Convolute wheels must always run in the direction indicated by the arrow printed on the side of each wheel.
- Light to medium pressure is recommended. Excessive pressure may result in part damage.
- Lubricants such as water-soluble oil and straight oil will decrease the heat and improve the surface finish and lustre.

! It is the user's responsibility to refer to and comply with all safety regulations.



Convolute Wheels CONTINUED



SERIES 1000 CONVOLUTE WHEELS

BETTER CHOICE FOR GENERAL DEBURRING, BLENDING, AND FINAL FINISHING

FEATURES

- Smear and heat-resistant formula
- Dense web construction (9 density)
- More open web construction (7 density)
- Waterproof
- Non-metallic
- Optimum grain/resin formulation
- Conformable and flexible

BENEFITS

- Consistent, high quality results
- Starting point for deburring, blending, polishing and finishing applications
- Smear-proof and cool cutting on light deburring applications
- Use dry, wet or with oil
- No contamination of workpiece
- Durable, long life construction with versatile application range and improved cut rate and shed resistance
- Less operator fatigue

AVAILABILITY

TIER:

BETTER

TRADENAME:

SERIES 1000 CONVOLUTE WHEELS

SIZE (D X T X H)	ABRASIVE	GRIT	MAX. RPM	STD. PKG.	7 DENSITY PART NO.	8 DENSITY PART NO.	9 DENSITY PART NO.		
SERIES 1000 LONG LIFE CONVOLUTE WHEELS									
6 x 1/2 x 1	A/O	M	6,000	4	66261018857	66261018789	66261018650		
	S/C	M					66261019540		
	S/C	F					66261018628	66261018629	
6 x 1 x 1	A/O	M	6,000	3	69957397884	66261018636	66261019337		
	S/C	M					69957397882	66261018630	
	S/C	F					66261018631	66261018774	66261018632
8 x 1 x 3	A/O	M	4,500	3	69957397885	66261018855	66261018633		
	S/C	M					69957394610	66261018673	66261018997
	S/C	F					66261018639	66261018640	66261018641
12 x 1 x 5	A/O	M	3,000	2	69957397887	66261018786	66261018896		
	S/C	M					66261018908		
	S/C	F					66261018626		



LIGHT FINISHING CONVOLUTE WHEELS

BEST CHOICE FOR LIGHT DEBURRING, POLISHING, AND FINE FINISHING APPLICATIONS

FEATURES

- Controlled cut rate
- Very conformable
- Superior form holding
- New resin bond system
- Advanced manufacturing process

BENEFITS

- Prevents "over benching"
- Deburrs and polishes without altering geometry
- Operator friendly, reduces fatigue
- Consistent, reliable edge breaking and finishing with minimal wheel dressing and reshaping
- Less dust and shedding with more uniform wear
- Substantial extended wheel life in a soft, conformable wheel
- Improved web forming and grain distribution produce consistent finish on intricate polishing applications

AVAILABILITY

TIER:

BEST

TRADENAME:

LIGHT FINISHING CONVOLUTE WHEELS

SIZE (D X T X H)	ABRASIVE	GRIT	MAX. RPM	STD. PKG.	6 DENSITY PART NO.	7 DENSITY PART NO.	8 DENSITY PART NO.
LIGHT FINISHING CONVOLUTE WHEELS							
6 x 1/2 x 1	S/C	F	6,000	4	66261092322	66261092324	66254421572
6 x 1 x 1	S/C	F	6,000	3	66254403708	66254403709	66254421573
8 x 1/2 x 3	S/C	F	4,500	4	66254403707	66254409698	66254421575
8 x 1 x 3	S/C	F	4,500	3	66261095702	66254409924	66254421577
12 x 1 x 5	S/C	F	3,000	3		66261092480	66254421574*

* 2 PER STANDARD PACKAGE



Convolute Wheels CONTINUED



METAL FINISHING CONVOLUTE WHEELS

BEST CHOICE FOR DECORATIVE FINISHING, BLENDING, AND FINAL FINISHING

FEATURES

- Premium, medium grit aluminum oxide grain
- Dense, very durable web
- Strongest resin binders
- Uniform grain dispersion and coating
- Available in 5 and 6 densities

BENEFITS

- Generates uniform distinct satin and antique finishes
- Can be used for blending applications
- Resilient, long life construction
- Clean and condition without gouging or changing dimensions of workpiece
- Ideal for blending and matching #3 and 4 mil. finishes, and surface prep for buffing, polishing and applying decorative finishes

AVAILABILITY

TIER: **BEST**
 TRADENAME: **METAL FINISHING CONVOLUTE WHEELS**

SIZE (D X T X H)	ABRASIVE	DENSITY	GRIT	MAX. RPM	STD. PKG.	PART NO.
METAL FINISHING CONVOLUTE WHEELS						
6 x 1 x 1	A/O	5	M	6,000	3	66261007936
		6	M			66261010148
6 x 2 x 1	A/O	5	M	6,000	2	66261007957
		6	M			66261009635
8 x 1 x 3	A/O	5	M	4,500	3	66261007831
8 x 2 x 3	A/O	5	M	4,500	2	66261007904
		6	M			66261012971
12 x 1 x 5	A/O	5	M	3,000	2	66261007434
		6	M			66261009481
12 x 2 x 5	A/O	5	M	3,000	1	66261007212
14 x 2 x 8	A/O	5	M	2,550	1	66261007817
		6	M			66261012041



CLEAN & FINISH CONVOLUTE WHEELS

BEST CHOICE FOR FINE FINISH WITH LIGHT PRESSURE

FEATURES

- Silicon carbide grain
- Open mesh construction

BENEFITS

- Good for blending, rust removal, applying decorative, contrast finishes and low- to moderate-speed applications
- Not used for deburring
- Used with light to moderate pressure, low speed

AVAILABILITY

TIER: **BEST**
 TRADENAME: **CLEAN & FINISH CONVOLUTE WHEELS**

SIZE (D X T X H)	ABRASIVE	GRIT	DENSITY	MAX. RPM	STD. PKG.	PART NO.
CLEAN & FINISH CONVOLUTE WHEELS						
4 x 1 x 1	S/C	M	4	4,000	10	66261058502
		F	4			66261058501
6 x 1 x 1	S/C	M	4	3,000	4	66261058507
		F	4			66261058506
6 x 2 x 1	S/C	M	4	3,000	2	66261058510
		F	4			66261058509
6 x 3 x 1	S/C	M	4	3,000	1	66261058512
6 x 4 x 1	S/C	M	4	3,000	1	66261058514
8 x 1 x 3	S/C	M	4	2,500	3	66261058518
8 x 2 x 3	S/C	M	4	2,500	2	66261058521
8 x 3 x 3	S/C	M	4	2,500	1	66261058524
8 x 4 x 3	S/C	M	4	2,500	1	66261058526

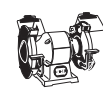

Aluminum Reducing Bushings for Flap and Convolute Wheels



- Durable, aluminum one-piece-design flanges with integrated “contact washer”
- Snug fit; extended usable life
- Available in stock and non-stock sizes: 3" up to 10" in many combinations of ID hole reduction

<i>WHEEL CENTER HOLE</i>	<i>BUSHING REDUCES HOLE SIZE TO</i>	<i>FOR WHEEL DIAMETER</i>	<i>STD. PKG.</i>	<i>PART NO.</i>
ALUMINUM REDUCING BUSHING FOR FLAP AND CONVOLUTE WHEELS				
1	3/8	4 - 6	1 Pair	66261080522
	1/2			66261080523
	5/8			66261080524
	3/4			66261080525
	7/8			66261080526
2	1/2	6	1 Pair	66261080527
	5/8			66261080528
	1			66261080529
	1-1/4			66261080530
3	1	8	1 Pair	66261080531
	1-1/4			66261080532
	1-1/2			66261080383
	1-3/4			66261080384
	2			66261080514
5	1	10 and 12	1 Pair	66261080533
	1-1/4			66261080534
	3			66261080535
8	1-1/4	14	1 Pair	66261080536
	3			66261080512
10	1-1/4	16	1 Pair	66261080520



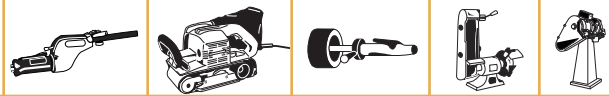

CATEGORY DEFINITION

Norton non-woven belts are a combination of strong synthetic mesh and quality abrasive, bonded together by a smear-resistant adhesive. The open construction of non-woven material enables aggressive cutting action and improved surface finish while maintaining its non-loading feature.

The belts are color-coded by grit size for easy identification. Choose Coarse for deburring, Medium for cleaning/blending, and Very Fine for finishing.

APPLICATIONS: Removing surface defects, light edge burrs, parting lines, flashing, rust, oxides, corrosion, paints, and scale; blending mill marks, tool marks, uneven edges, and applying decorative finishes.

ABRASIVE GRAIN: Aluminum Oxide

GRIT RANGE: Coarse (Brown), Medium (Maroon), Very Fine (Blue)

FEATURED PRODUCTS



NORTON STE-VS BETTER CHOICE FOR FINISHING AND BLENDING APPLICATIONS

FEATURES

- Slightly open structure
- High abrasive content
- Firm backing

BENEFITS

- Resists loading
- Continuous cut rate on soft (e.g. aluminum) and hard materials (e.g. steels and nickel alloys)
- Low stretch



NORTON STE GOOD CHOICE FOR CLEANING, POLISHING AND OTHER LOW FORCE APPLICATIONS

FEATURES

- Open structure
- Flexible backing

BENEFITS

- Resists loading on softer materials (aluminum, gaskets, etc.)
- Conformable

AVAILABILITY



TIER:

TRADENAME:

ABRASIVE:

BETTER

STE-VS

Aluminum Oxide

GOOD

STE

Aluminum Oxide

SIZE (D X H)	GRIT SIZE	STD. PKG.	PART NO.	PART NO.
FILE BELTS 1/2 x 18	Coarse	24	66261009048	66261055309
	Medium		66261008814	66261055310
	Very Fine		66261006762	66261055311
1/2 x 24	Coarse	24	66261008972	66261055312
	Medium			66261055313
	Very Fine			66261055314
3/4 x 18	Coarse	24	66261008813*	08834194006
	Medium		66261006546*	08834194007
	Very Fine			08834194008
3/4 x 20-1/2	Coarse	24		08834194009
	Medium			08834194010
	Very Fine			08834194011

*12 PER STANDARD PACKAGE





AVAILABILITY



TIER:

STE-VS

STE

TRADENAME:

STE-VS

STE

ABRASIVE:

Aluminum Oxide

Aluminum Oxide

SIZE (D X H)	GRIT SIZE	STD. PKG.	PART NO.	PART NO.
IN-LINE BELTS				
3-1/2 x 15-1/2	Coarse	8	08834199009	66261055324
	Medium		08834198042	66261055325
	Very Fine			66261055326
PORTABLE BELTS				
3 x 24	Coarse	12		08834194036
	Medium			08834194037
	Fine			08834194038
4 x 24	Coarse	12		08834194045
	Medium			08834194046
	Very Fine			08834194047
BENCHSTAND BELTS				
1 x 42	Coarse	12		08834194012
	Medium			08834194013
	Very Fine			08834194014
2 x 48	Coarse	12		08834194015
	Medium			08834194016
	Very Fine			08834194017
2 x 60	Coarse	12	08834199006	08834194018
	Medium		08834198039	08834194019
	Very Fine			08834194020
2 x 72	Coarse	12		08834194021
	Medium			08834194022
	Very Fine			08834194023
2-1/2 x 60	Coarse	12		08834194030
	Medium			08834194031
	Very Fine			08834194032
4 x 36	Coarse	12		08834194048
	Medium			08834194049
	Very Fine			08834194050
4 x 54	Coarse	12		08834194051
	Medium			08834194052
	Very Fine			08834194053
6 x 48	Coarse	4		66261055330
	Medium			66261055331
	Very Fine			66261055332
BACKSTAND BELTS				
2 x 132	Coarse	6	66261017512	08834194024
	Medium		66261008492	08834194025
	Very Fine			08834194026
3 x 132	Coarse	6		08834194039
	Medium			08834194040
	Very Fine			08834194041
4 x 132	Coarse	6		08834194054
	Medium			08834194055
	Very Fine			08834194056

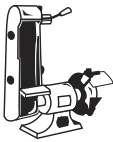

If you do not see the STE and STE-VS belts you need in our stock offering, call your local Norton distributor to check for made-to-order availability.



CATEGORY DEFINITION

Non-woven surface finishing flap wheels are an ideal choice for a wide variety of blending and finishing applications common in the metal fabrication, welding and polishing industries. Flap wheels are conformable to intricate shapes and contours. Designed to deliver a consistent finish with a uniform rate of cut, flap wheels wear away continually exposing fresh abrasives.

There are two types of non woven flap wheels: non-woven only abrasive flaps where finishing is the primary application, and interleaf with alternating cloth and non-woven abrasive flaps (less conformable, more aggressive) for stock removal and finishing. Interleaf flap wheels must always be run in the direction indicated by the arrow.

- APPLICATIONS: Used for a wide range of metal fabrication and welding applications including blending, deburring, cleaning, finishing, and polishing
- SIZE RANGE: Flap wheels with mounted steel shanks: 2" – 3" diameter
Flap wheels with arbor holes: 3" – 12" diameter
- GRIT RANGE: 50 – 320
- ABRASIVE GRAIN: Aluminum Oxide, Silicon Carbide

APPLICATION/GRIT RECOMMENDATION GUIDE

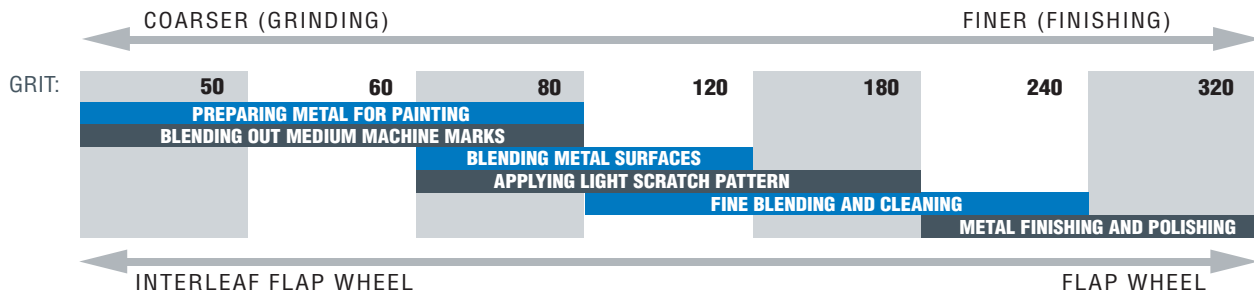

1/4" Mounted Steel Shanks

AVAILABILITY

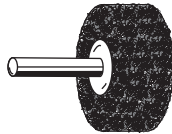

TIER:

BRAND:

TRADENAME:

BETTER	GOOD	BETTER	GOOD
Norton	Merit	Norton	Merit
INTERLEAF	INTERLEAF	NON-WOVEN	NON-WOVEN

SIZE (D X W X SK.)	MAX. RPM	ABRASIVE	CA GRIT	NON-WOVEN GRIT	STD. PKG.	PART NO.	PART NO.	PART NO.	PART NO.
2 x 1 x 1/4	12,000	A/O	60	Coarse	10	66261051720*	08834138122		
		A/O	80	Medium		66261051721*	08834138123		
		A/O	120	Medium		66261051722*	08834144457	66261051716*	66261189992*
		A/O	180	Fine			08834144458		
		A/O	320	Very Fine			08834144459	66261051717*	69957399202*
2 x 1-1/2 x 1/4	12,000	A/O	60	Coarse	10		08834138124		
		A/O	80	Medium			08834138125		
		A/O	120	Medium			08834138126		
		A/O	180	Fine			08834138127		
		A/O	320	Very Fine			08834138128		
3 x 1 x 1/4	12,000	A/O	60	Coarse	10		08834138129		
		A/O	80	Medium			08834138130		
		A/O	120	Medium		66261051725*	08834138118	66261051718*	08834131921
		A/O	180	Fine			08834138120		
		A/O	–	Very Fine				66261051719*	66261189993
3 x 1-3/4 x 1/4	12,000	A/O	–	Medium	10				66261026075
		A/O	–	Very Fine					66261189994
3 x 2 x 1/4	8,000	A/O	60	Grit	10		08834131338		
		A/O	80	Coarse			08834138116		
		A/O	120	Medium			08834144460	66261058474	
		A/O	180	Medium			08834144461		
4 x 2 x 1/4	12,000	A/O	80	Coarse	10		08834121115		
		A/O	120	Medium			08834120458		

*STANDARD PACKAGE QUANTITY = 20



Arbor Hole Mounts

AVAILABILITY



TIER:

BRAND:

TRADENAME:



Norton

Merit

Norton

Merit

INTERLEAF

INTERLEAF

NON-WOVEN

NON-WOVEN

SIZE (D X W X H)	MAX. RPM	ABRASIVE	CA GRIT	NON-WOVEN GRIT	STD. PKG.	PART NO.	PART NO.	PART NO.	PART NO.
3 x 2 x 3/8	12,000	A/O	50	Coarse	10				
		A/O	60	Coarse					
		A/O	80	Medium					
		A/O	120	Medium					
		A/O	180	Fine					
		A/O	240	Very Fine					
		A/O	320	Very Fine					
4 x 2 x 5/8	12,000	A/O	50	Coarse	10				
		A/O	60	Coarse					
		A/O	80	Medium					
		A/O	120	Medium					
		A/O	180	Fine					
		A/O	240	Very Fine					
		A/O	320	Very Fine					
6 x 1 x 1	6,000	A/O	50	Coarse	10				
		A/O	60	Coarse					
		A/O	80	Medium					
		A/O	120	Medium					
		A/O	150	Medium					
		A/O	180	Fine					
		A/O	240	Very Fine					
A/O	320	Very Fine							
6 x 1 x 2	3,000	A/O	80	Medium	4	66261004418 66261007678 66261005387		66261058456 66261058487 66261058451 66261058450	05539512667 05539562635 05539512660 05539512658
		A/O	120	Medium					
		A/O	180	Fine					
		S/C	-	Fine					
		S/C	-	Very Fine					
6 x 2 x 1	6,000	A/O	50	Coarse	10				
		A/O	60	Coarse					
		A/O	80	Medium					
		A/O	120	Medium					
		A/O	150	Medium					
		A/O	180	Fine					
		A/O	240	Very Fine					
A/O	320	Very Fine							
6 x 3 x 1	6,000	A/O	50	Coarse	6				
		A/O	60	Coarse					
		A/O	80	Medium					
		A/O	120	Medium					
		A/O	180	Fine					
		A/O	240	Very Fine					
		A/O	320	Very Fine					
8 x 1 x 3	2,500	A/O	120	Medium	3	66261010711		66261058491	05539527460
		-	-	Fine					
8 x 2 x 1	4,500	A/O	60	Coarse	6				
		A/O	80	Medium					
		A/O	120	Medium					
		A/O	180	Fine					
8 x 2 x 3	2,500	A/O	-	Medium	2			66261000889 66261058493	05539512677 05539526627
		A/O	-	Medium					
		A/O	-	Fine					
8 x 3 x 1	4,500	A/O	50	Coarse	3				
		A/O	60	Coarse					
		A/O	80	Medium					
		A/O	120	Medium					
		A/O	180	Fine					
		A/O	320	Very Fine					
12 x 1 x 5	1,900	A/O	80	Medium	2	66261010712 66261004667			
		A/O	120	Medium					
12 x 2 x 5	1,900	A/O	-	Medium	1			66261005070	05539528945 05539562637
		A/O	-	High Strength					

Refer to Non-Woven Convolute Wheel section for Flap Wheel Reducing Bushings.





MERIT

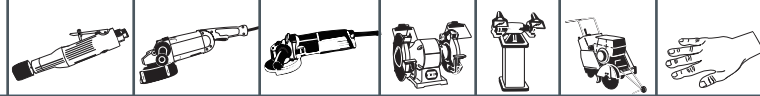

CATEGORY DEFINITION

Our broad Merit wire brush offering includes all the basic shapes and configurations: cups, saucer cups, wheel end brushes and hand brushes. Attractive packaging clearly explains dimensions, structure, safety and machine usage. All brushes are individually clamshell packaged unless otherwise noted. When using wire brushes, be sure to comply with ANSI B165 "Power-Driven Brushing Tools: Safety Requirement for the Design, Care and Use." and Safety documents on www.nortonabrasives.com website.

APPLICATIONS: Cleaning rust, scale and dirt; light deburring; edge blending; roughening for adhesion; finishing for appearance; finish preparation prior to plating or painting

SHAPES: Cup, saucer cup, wheel, end brush, hand brush

WIRE DESIGN: Standard and full cable twist knot, crimped, stringer bead

OTHER: Color-coded for easy identification; **STAINLESS** **STEEL/METAL**

FEATURED PRODUCTS AND AVAILABILITY

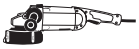

BETTER WIRE SAUCER CUP BRUSHES

IDEAL FOR CLEANING CORNERS, RECESSES, AND OTHER HARD-TO-REACH AREAS – FOR STEEL/STAINLESS

FEATURES

- Twist knot style
- Crimped style

BENEFITS

- For heavy-duty cleaning
- For light- to medium-duty cleaning

DIAMETER X WIRE THICKNESS X MOUNT	MAX. RPM	STD. PKG.	APPLICATION	PART NO.
TWIST KNOT SAUCER CUP				
4 x .020 x 5/8-11	15,000	5	Carbon	66252833483
5 x .020 x 5/8-11	12,500	5	Carbon	66252833585
5 x .020 x 5/8-11	12,500	5	Stainless	66252833586
CRIMPED SAUCER CUP				
4 x .014 x 5/8-11	15,000	5	Carbon	66252833485

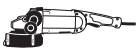

BETTER HIGH PERFORMANCE (HP) CABLE CRIMPED CUP BRUSHES

FOR LIGHT- TO MEDIUM-DUTY BRUSHING APPLICATIONS ON FLAT OR IRREGULAR SURFACES, AND BEVEL BUFFING – FOR STEEL

FEATURES

- 12 wires of .009" brass-coated steel are bundled together into a group, then crimped
- Cable crimped wire breaks down in smaller pieces than standard crimped brushes

BENEFITS

- Creates a 50% longer lasting brush compared to standard crimped brushes; better flexibility on irregular surfaces
- Safer wire to use
- Protective guard

DIAMETER X WIRE THICKNESS X MOUNT	MAX. RPM	STD. PKG.	APPLICATION	PART NO.
CRIMPED CUP WITH PROTECTIVE GUARD – SINGLE ROW				
3 x (12 x .009) x 5/8-11	15,000	5	Carbon	66252833493
4 x (12 x .009) x 5/8-11	9,000	5	Carbon	66252833494
5 x (12 x .009) x 5/8-11	6,500	5	Carbon	66252833495

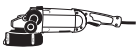

BETTER CRIMPED WIRE CUP BRUSHES

FOR LIGHT- TO MEDIUM-DUTY BRUSHING APPLICATIONS ON FLAT OR IRREGULAR SURFACES, AND BEVEL BUFFING – FOR STEEL

FEATURES

- Highly flexible heavy wire fill

BENEFITS

- Fast cutting

DIAMETER X WIRE THICKNESS X MOUNT	MAX. RPM	STD. PKG.	APPLICATION	PART NO.
3 x .014 x 5/8-11	15,000	5	Carbon	69936653341
4 x .014 x 5/8-11	9,000	5	Carbon	69936653347
6 x .014 x 5/8-11	6,000	5	Carbon	69936653348
6 x .020 x 5/8-11	6,000	5	Carbon	69936653349

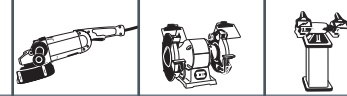

FEATURED PRODUCTS AND AVAILABILITY

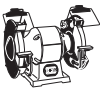
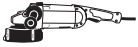

BETTER TWIST KNOT WIRE CUP BRUSHES

HIGH IMPACT CUTTING AND CLEANING ON MORE DEMANDING APPLICATIONS – FOR STEEL/STAINLESS

FEATURES

- Rigid structure
- Available with or without plastic guard
- Protective guard opens up into a shield
- Single row, twist knot construction
- Double row, twist knot construction

BENEFITS

- High impact cutting and cleaning on more demanding applications
- Application-specific
- Prevents wire, dust and/or projection from reaching the end-user
- Provides for a friendly handling of the brush, preventing potential pricking caused by the wire ends
- Limits flaring of the brush on corners and angles
- More aggressive; provides twice the cutting points of a single row cup brush for heavy-duty action in very severe applications

DIAMETER X WIRE THICKNESS X MOUNT	MAX. RPM	STD. PKG.	APPLICATION	PART NO.
KNOTTED CUP WITH PROTECTIVE GUARD – SINGLE ROW				
2-3/4 x .020 x 5/8-11	15,000	5	Carbon	66252833492
4 x .020 x 5/8-11	9,000	5	Carbon	66252833496
5 x .020 x 5/8-11	6,500	5	Carbon	66252833497
KNOTTED CUP – SINGLE ROW				
2-3/4 x .020 x 5/8-11	15,000	5	Carbon	69936653336
2-3/4 x .020 x 5/8-11	15,000	5	Stainless	69936653340
2-3/4 x .020 x M10-1.25 / 1.50	15,000	5	Carbon	69936653338
4 x .020 x 5/8-11	9,000	5	Carbon	69936653345
4 x .020 x 5/8-11 with bridle	9,000	5	Stainless	66252833947
6 x .020 x 5/8-11	6,000	5	Carbon	69936605965
6 x .035 x 5/8-11	6,000	5	Carbon	69936602003
KNOTTED CUP – DOUBLE ROW				
6 x .020 x 5/8-11	6,000	5	Carbon	69936653346

BETTER CRIMPED WIRE WHEEL BRUSHES

EXCELLENT PERFORMANCE FOR DEBURRING, REMOVING RUST, CORROSION AND DIRT – FOR STEEL

FEATURES

- Brushes may be used individually or stacked on a shaft

BENEFITS

- Single-section, narrow-faced brushes are ideal for general-purpose brushing of uneven or difficult-to-reach surfaces
- Single section, medium-faced brushes clean larger surface areas and have longer life

DIAMETER X WIRE THICKNESS X HOLE SIZE	MAX. RPM	STD. PKG.	APPLICATION	PART NO.
CRIMPED NARROW 3/4" FACE				
6 x .014 x 1/2-2**	6,500	5	Carbon	69936653306
CRIMPED MEDIUM 1" FACE				
6 x .014 x 1/2-2**	6,500	5	Carbon	69936653324
8 x .014 x 1/2-2**	4,500	5	Carbon	69936653326

** 7 BUSHING SIZES INCLUDED WITH EACH BRUSH (FIT 1/2" - 2")

- STAINLESS
- STEEL/METAL



FEATURED PRODUCTS AND AVAILABILITY

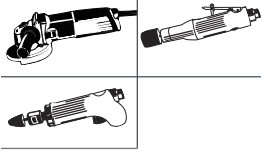

BETTER STANDARD TWIST KNOT WIRE WHEEL BRUSHES

IDEAL FOR WELDING AND METAL FABRICATION APPLICATIONS (REMOVING WELD SCALE SPATTER, EXTRA-HEAVY RUST AND CORROSION, OR SURFACE ROUGHENING) – FOR STEEL

FEATURES

- Twist knot wire design

BENEFITS

- Provides added rigidity for extra cutting power
- Small diameter wheels are used for small- to medium-duty jobs requiring flexibility and lighter brushing action

DIAMETER X WIRE THICKNESS X MOUNT/HOLE	MAX. RPM	STD. PKG.	APPLICATION	PART NO.
3 x .015 x 3/8-1/2	20,000	5	Carbon	69936653314
4-1/2 x .020 x 5/8-11	20,000	5	Carbon	69936606275



BETTER FULL CABLE TWIST KNOT WIRE WHEEL BRUSHES

FOR THE TOUGHER APPLICATIONS, ESPECIALLY FOR WELD PASSES – FOR STEEL/STAINLESS

FEATURES

- Full cable twist brushes
- NEW! Pipeline: heavy-duty knot construction

BENEFITS

- Provide very low flex and high impact cutting and cleaning
- Stiffer, longer-lasting knots for tougher applications / heavy build-up

DIAMETER X WIRE THICKNESS X MOUNT	MAX. RPM	STD. PKG.	APPLICATION	PART NO.
4 x .020 x 5/8-11	20,000	5	Carbon	66252838300
4-1/2 x .020 x 5/8-11	20,000	6*	Carbon Pipeline	66252840466
4-1/2 x .020 x M10 x 1.25 / 1.50	20,000	5	Stainless	69936653334
4-1/2 x .020 x 5/8-11	20,000	6*	Carbon	69936653331
4-1/2 x .020 x 5/8-11	20,000	5	Stainless	69936653333
5 x .020 x 5/8-11	12,500	5	Carbon	66252833487
5 x .020 x 5/8-11	12,500	5	Stainless	66252833488
6 x .020 x 5/8-11	12,500	5	Carbon	69936653352
6 x .020 x 5/8-1/2	12,500	5	Carbon	69936653327

*BULK PACKED ITEMS



BETTER STRINGER BEAD KNOT WIRE WHEEL BRUSHES

DELIVER HIGH-IMPACT CUTTING AND CLEANING FOR TOUGHEST APPLICATIONS – FOR STEEL/STAINLESS

FEATURES

- Stringer bead wire for hard-to-reach areas
- Joint/Crack cleaning wire wheel brushes

BENEFITS

- Specially suited for groove and weld bead, corners, and t-connections
- Used for brushing joints, cleaning cracks in concrete and asphalt, and preparing expansion joints for filling and scaling
- NEW! Pipeline: longest life for brushing/cleaning joints and preparing expansion joints for filling and scaling

DIAMETER X WIRE THICKNESS X MOUNT	MAX. RPM	STD. PKG.	APPLICATION	PART NO.
FOR RIGHT ANGLE GRINDERS				
4 x .020 x 5/8-11	20,000	5	Carbon	69936606277
4 x .020 x 5/8-11	20,000	6*	Carbon	66252833489
4 x .020 x 5/8-11	20,000	6*	Carbon Pipeline	66252840467
4 x .020 x 5/8-11	20,000	5	Stainless	69936606278
5 x .020 x 5/8-11	12,500	6*	Carbon	66252833490
5 x .020 x 5/8-11	12,500	6*	Stainless	66252833491
6 x .020 x 5/8-11	12,500	10*	Carbon	69936653350
6 x .020 x 5/8-11	12,500	10*	Carbon Pipeline	66252840469
6 x .020 x 5/8-11	12,500	5	Stainless	69936653351
6-7/8 x .020 x 5/8-11	9,000	10*	Carbon	69936653329
6-7/8 x .020 x 5/8-11	9,000	10*	Carbon Pipeline	66252840468
9 x .020 x 5/8-11	6,000	2	Carbon	66252837993

FOR WALK-BEHIND MACHINES – JOINT/CRACK CLEANING BRUSHES

12 x .035 x 1 - DP	4,500	2*	Carbon	69936606280
--------------------	-------	----	--------	-------------

*BULK PACKED ITEMS



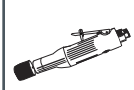

FEATURED PRODUCTS AND AVAILABILITY



BETTER END BRUSHES

CLEAN AND DEBURR A RECESSED AREA OR THE INSIDE DIAMETER OF A TUBE OR PIPE – FOR STEEL/STAINLESS

FEATURES

- Twist knot wire end brushes
- Crimped wire end brushes

BENEFITS

- For more aggressive cutting
- For lighter brushing action and contoured surfaces

DIAMETER X WIRE THICKNESS X MOUNT	MAX. RPM	STD. PKG.	APPLICATION	PART NO.
STEM MOUNTED KNOTTED				
3/4 x .020 x 1/4 Shank	20,000	10*	Carbon	69936653316
1 x .014 x 1/4 Shank	20,000	10*	Carbon	69936606279
1 x .020 x 1/4 Shank	20,000	10*	Carbon	69936653310
STEM MOUNTED CRIMPED				
3/4 x .006 x 1/4 Shank	20,000	10*	Stainless	69936606145
3/4 x .014 x 1/4 Shank	20,000	10*	Carbon	69936653317
1 x .020 x 1/4 Shank	20,000	10*	Carbon	69936653309
COPPER CENTER				
2-1/2 x .014 x 1/2-3/8	20,000	12*	Carbon	69936653320

*BULK PACKED ITEMS



BETTER HAND BRUSHES

FOR STEEL/STAINLESS

FEATURES

- Plastic handle scratch brush
- Long handle and shoe handle brushes

BENEFITS

- Ergonomic handle
- Crimped wire for longer life
- Wires are wrapped up and around the metal post so they never come out
- Curved face for hard-to-reach places
- Narrow brush allows access into tight areas and slots
- Steel scratch brushes are made with a high-carbon, brass-coated steel; stainless steel is made with a 304L stainless

SIZE	STD. PKG.	APPLICATION	PART NO.
Scratch Brush 3 x 19 Long Handle	12	Carbon	66252833948
Scratch Brush 3 x 19 Long Handle	12	Stainless	66252833950
Scratch Brush 4 x 16 Shoe Handle	24	Carbon	66252833949
Scratch Brush 4 x 16 Shoe Handle	24	Stainless	66252833951
Scratch Brush Plastic Handle	24	Carbon	66252833954
Scratch Brush Plastic Handle	24	Stainless	66252833953
Inspection Brush 3 x 7	36	Stainless	66252833952

STAINLESS
STEEL/METAL



Micro-Fiber Cloths

- A micro-fiber is a single fiber with a thickness less than a human hair that has been split 16 times and woven into various products.
- The surface area of a micro-fiber product is increased over 15 times, creating millions of spaces between the fibers which trap dirt, grime or liquids, making this product one of the most absorbent materials.
- Use these micro-fiber cloths dry for general cleaning.
- To remove spills, stains or grime, lightly dampen the cloth for best results.
- All micro-fiber cloths can be used with or without chemicals.
- Micro-fiber cloths can be washed up to 300+ times without losing cleaning and trapping abilities.
- Clean often for best results.
- They save you labor, time, and additional costs of multiple cleaning products and chemicals.

<i>DESCRIPTION</i>	<i>COLOR</i>	<i>STD. PKG.</i>	<i>PART NO.</i>
--------------------	--------------	------------------	-----------------

MICRO-FIBER CLEANING CLOTH (BLUE)

Used for general-purpose wet or dry applications. Works best when sprayed with a light water mist to deep clean.

16" x 16" Cleaning Cloth	Blue	20	07660705300
--------------------------	------	----	-------------

MICRO-FIBER DRY TACK CLOTH (RED)

This woven terry cloth has a low profile to resist snagging and help pick up embedded debris. It is used in dry tack applications.

16" x 16" Dry Tack Cloth	Red	20	07660704025
--------------------------	-----	----	-------------

MICRO-FIBER POLISHING CLOTH (YELLOW)

Streak-free cleaning of mirrors, optical lens and highly-polished items.

16" x 16" Polishing Cloth	Yellow	20	07660705301
---------------------------	--------	----	-------------



Black Lambswool Polishing Pads

- Designed to repair clearcoat finishes, these pads are 100% natural lambswool which has the densest pile of any material.
- They are well-balanced and more durable than conventional pads.
- Fibers can be compressed and still recover their natural shape.
- Because of the denser pile surface, these pads distribute and apply material evenly and consistently.
- Available in 3" – 5" diameters with a 3/4" nap to attach to a hook and loop back-up pad.

<i>DESCRIPTION</i>	<i>STD. PKG.</i>	<i>PART NO.</i>
BLACK LAMBSWOOL POLISHING PADS		
3" Pad with Loop – 3/4" nap	500	63642503670
4" Pad with Loop – 3/4" nap	250	63642503671



Norton Professional High Heat Tape

Designed for maximum performance and clean release on multiple surfaces. These high quality masking tapes are ideal for conditions that include exposure to the high heat curing temperatures found in automobile, truck, bus and other transportation assembly operations, as well as aerospace manufacturing applications where a conformable, clean release masking tape is required. Available in bulk, accordion-wrapped for protection and work site stocking.

PART #	SIZE	STD. PKG.
NORTON PROFESSIONAL HIGH HEAT TAPE		
07660721948	3/4" x 60 yards	48
07660721949	1" x 60 yards	36
07660721950	1-1/2" x 60 yards	24
07660721951	2" x 60 yards	24

PACKED IN SLEEVES, WITH 4 SLEEVES TO A CASE



Norton Contractor Grade Tape

A general-purpose masking tape that offers both economy and versatility for a variety of materials and applications. Norton Contractor Grade masking tape provides a clean release up to 3 days. Use for general paint masking, hanging protective plastic, holding drop cloths in place and other general-purpose masking, bundling, and sealing jobs where the tape will be removed when the job is complete. Not intended for critical paint applications. Limit exposure to UV light for extended periods. Extended exposure to UV light could result in difficult removal from the surface.

PART #	SIZE	STD. PKG.
NORTON CONTRACTOR GRADE TAPE		
07660721944	3/4" x 60 yards	48
07660721945	1" x 60 yards	36
07660721946	1-1/2" x 60 yards	24
07660721947	2" x 60 yards	24

BULK PACKED AS INDIVIDUAL ROLLS



Norton Blue Core Tape

Our premium paint masking tape has a specially formulated adhesive system that provides optimum low- to medium-tack adhesion and clean removal from a variety of surfaces, for up to 14 days. Norton Blue Core masking tape can be used indoors or out. The crepe paper backing is designed to enable easy unrolling and to minimize slivering. It delivers very sharp, clean edges on smooth- to moderately-textured surfaces.

PART #	SIZE	STD. PKG.
NORTON BLUE CORE TAPE		
07660721952	3/4" x 60 yards	48
07660721953	1" x 60 yards	36
07660721954	1-1/2" x 60 yards	24
07660721955	2" x 60 yards	24

BULK PACKED AS INDIVIDUAL ROLLS





NORTON
QUANTUM

VORTEX
technology

NORTON
BRG
g



CATEGORY DEFINITION

Used on surface, cylindrical, and tool and cutter grinders, Norton precision, form-holding vitrified toolroom wheels maximize your productivity. Available in latest-generation ceramic alumina, aluminum oxide, and silicon carbide – for every ferrous and nonferrous MRO, small job shop, and production operation.

APPLICATIONS:	Surface grinding, tool and cutter grinding, drill sharpening
SHAPES:	Type 01 Straight, Type 02 Cylinder, Type 05 and 07 Recessed 1 and 2 Sides, Type 06 and 11 Straight and Flaring Cups, Type 12 Dish, Type 20 Concaved 1 Side, and Type 35 Plate Mounted Disc
SIZE RANGE:	3/4" – 14" diameter
GRIT RANGE:	46 – 220
ABRASIVE GRAIN:	Ceramic Alumina, Aluminum Oxide, Silicon Carbide

MATERIAL-TO-PRODUCT RECOMMENDATION GUIDE

PERFORMANCE/PRODUCTIVITY APPLICATION / MATERIAL	NARROW CONTACT AREA			MEDIUM CONTACT AREA			WIDE CONTACT AREA		
	BEST	BETTER	GOOD	BEST	BETTER	GOOD	BEST	BETTER	GOOD
Tool Resharpener									
• Heavy Stock Removal (> .004) HSS & Tool Steel RC 50-68	5SG46-KVS	32A46-KVBE	38A46-KVBE	5SG46-JVS	32A46-JVBE	38A46-JVBE	5SG46-GVSP 3SGR46-GVP2	32A46-GVBEP 48A46-GVP2	38A46-GVBEP 38A46-GVP2
• Moderate Stock Removal (.002-.004) HSS & Tool Steel RC 50-68	5SG60-KVS	32A60-KVBE	38A60-KVBE	5SG60-JVS	32A60-JVBE	38A60-JVBE	5SG60-GVSP 3SGR60-GVP2	32A60-GVBEP 48A60-GVP2	38A60-GVBEP
Carbide			39C60-JVK			39C60-JVK			
Surface Grinding									
• Heavy Stock Removal (> .004) HSS & Tool Steel RC 50-68 400 Series Stainless	5NQ46-JVS	32A46-JVBE	38A46-JVBE	5SG46-IVS	32A46-IVBE	38A46-IVBE	5SG46-GVSP 3SGR46-GVP2	32A46-GVBEP 48A46-GVP2	38A46-GVBEP 38A46-GVP2
Soft Steels RC 30-45 300 Series Stainless	5SG46-KVS	32A46-KVBE	38A46-KVBE	5SG46-JVS	32A46-JVBE	38A46-JVBE	5SG46-HVSP 3SGR46-HVP2	32A46-HVBEP 48A46-HVP2	38A46-HVBEP 38A46-HVP2
Cast Iron: Ductile & Gray	5SG46-KVS	32A46-KVBE	38A46-KVBE	5SG46-JVS	32A46-JVBE	38A46-JVBE	5SG46-HVSP 3SGR46-GVP2	32A46-HVBEP 48A46-HVP2	38A46-HVBEP 38A46-HVP2
Nonferrous Alloys			39C46-JVK			39C46-IVK			
• Moderate Stock Removal (.002-.004) HSS & Tool Steel RC 50-68 400 Series Stainless	5NQ60-JVS	32A60-JVBE	38A60-JVBE	5SG60-IVS	32A60-IVBE	38A60-IVBE	5SG60-GVSP 3SGR60-GVP2	32A60-GVBEP 48A60-GVP2	38A60-GVBEP
Soft Steels RC 30-45 300 Series Stainless	5SG60-KVS	32A60-KVBE	38A60-KVBE	5SG60-JVS	32A60-JVBE	38A60-JVBE	3SGR60-HVP2	32A60-HVBEP 48A60-HVP2	38A60-HVBEP 38A60-HVP2
Cast Iron: Ductile & Gray	5SG60-KVS	32A60-KVBE	38A60-KVBE	5SG60-JVS	32A60-JVBE	38A60-JVBE	3SGR60-HVP2	32A60-HVBEP 48A60-HVP2	38A60-HVBEP 38A60-HVP2
Nonferrous Alloys			39C60-JVK			39C60-IVK			
• Light Stock Removal and Finishing (<.001) HSS & Tool Steel RC 50-68 400 Series Stainless		32A80-JVBE	38A80-JVBE		32A80-IVBE	38A80-IVBE		32A80-HVBE	38A80-HVBE
Soft Steels RC 30-45 300 Series Stainless		32A80-KVBE	38A80-KVBE		32A80-JVBE	38A80-JVBE		32A80-IVBE	38A80-IVBE
Cast Iron: Ductile & Gray		32A80-KVBE	38A80-KVBE		32A80-JVBE	38A80-JVBE		32A80-IVBE	38A80-IVBE
Nonferrous Alloys			39C80-JVK			39C80-IVK			39C80-HVK

VITRIFIED WHEELS

VITRIFIED WHEEL BONDS

BOND	DESCRIPTION
VS	Quantum (green) and Norton SG (blue): High stock removal; narrow/medium contact area; roughing/finishing; less burn; cool cutting.
VSP	Quantum (green) and Norton SG (blue): Porous bond; high stock removal; medium/wide contact area; cool cutting; less burn than VS; high chip clearance.
VBE	32A (purple), 38A (white) and 57A (brown): General purpose; narrow/medium contact area; versatile; economical.
VBEP	32A (purple) and 38A (white): Porous bond; medium/wide contact area; cool cutting; less burn than VBE; high chip clearance; high stock removal.
V	38A (orange): For fine grit, form/corner holding applications; narrow contact area.
VK	37C (black) and 39C (green): Designed specifically for silicon carbide abrasives; medium to narrow area of contact.
VCP	32A (purple) and 23A (blue/grey): Induced-pore, wide contact area, surface/creepfeed grinding applications.
VP2	3SGR (ruby), 48A (ruby), 25A (pink) and 38A (white): Unique, controlled-porosity (NORPOR) bond for heat-sensitive applications.

APPLICATION/GRIT RECOMMENDATION GUIDE

GRIT	REQUIREMENT	FINISH	MINIMUM CORNER RADIUS
46	General Purpose	32 Ra and rougher	0.020"
60	Commercial Finish	32 Ra and better	0.016"
80 – 100	Fine Finish	20 Ra and better	0.0105"
120	Very Fine Finish	10 Ra and better	0.006"
150	Corner-Form Holding		0.005"
180	Corner-Form Holding		0.0035"
220	Corner-Form Holding		0.0026"

CROSS REFERENCE GUIDE

NORTON	CAMEL	CINCINNATI	RADIAC	TYROLIT	WINTERTHUR
Quantum 5NQ		5M5B			
3SGR	AS3	3BP	7BP, 8BP		
5SG	SZA	5MSB	7BW, 8BW		
25A	PA	12A	RAA	88A	57A
32A	AZ	4A, 12A, 29A, 32A	32A, WRA	90A	67A, 68A
38A	83A, WA, AZ (Blue)	9A, 10A, 11A, 82A	WA, 9A	88A, 89A	53A, 49A, 42A
48A			RA	91A	68A
53A	91A, DA	29A, 97A	43A, 45A, 97A, WPA	50A	61A, 64A
57A	94A, CGW, A	A, AK	A	A, 52A	A
37C		6C	C	1C	C
39C		5C	GC	C	11C

STARTING RECOMMENDATIONS FOR TRUING AND DRESSING NORTON TOOLROOM WHEELS

TRUING & DRESSING: DRESSING STICK STARTING RECOMMENDATIONS			
SIZE/SPEC.	HIGH PERFORMANCE STICK PART NO.	SIZE/SPEC.	CONVENTIONAL STICK PART NO.
3 x 1/2 x 1/4" Norbide	61463610148	6 x 1 x 1" 37C24-SVK	61463610462
3 x 1/2 x 1/4" Boron Carbide	61463629472	8 x 1 x 1" 37C24-SVK	61463610471
other sizes are available			

DRESSING: SINGLE POINT DRESSING TOOL STARTING RECOMMENDATIONS					
WHEEL SIZES	TOOL SHANK DIAMETER	CERAMIC (NO, NORTON SG, TG, ETC.), 37C & 39C WHEELS PRODUCT NO. PART NO.		25A, 32A, 38A, 48A, 53A, 57A, 64A, 86A WHEELS PRODUCT NO. PART NO.	
Up to 7"	3/8	BCSG2M6	66260157007	BC2M6	66260195000
	7/16	BCSG2M7	66260156905	BC2M7	66260195001
8" to 10"	3/8	BCSG3M6	66260157008	BC3M6	66260195002
	7/16	BCSG3M7	66260156906	BC3M7	66260195003
12" to 14"	3/8	BCSG5M6	66260157009	BC5M6	66260195004
	7/16	BCSG5M7	66260156907	BC5M7	66260195005

THESE TOOLS ARE A STANDARD RECOMMENDATION; SEE THE "DIAMOND TOOL" SECTION FOR ADDITIONAL TOOLS
SEE THE FLIESEN TOOL SECTION FOR NEW FURIOSO TOOLS, ENGINEERED SPECIFICALLY FOR QUANTUM VITRIFIED WHEEL DRESSING

TROUBLESHOOTING GUIDE

Check the obvious first. Before changing the grinding wheel specification, investigate the following most common causes for most grinding problems:

1. Diamond dressing tool condition (check if worn or dull, rotate tool or replace if necessary)
2. Coolant direction, volume and filtration
3. Wheel dressing procedures (dress more open to free up cut rate, dress more closed to improve finish)

PROBLEM	POSSIBLE CAUSE	CORRECTION
Workpiece burn	Poor coolant direction Restricted or low coolant volume Wheel too hard Wheel structure too closed Wheel dressed too fine Worn dressing tool Work speed too slow Infeed too fast	Redirect coolant into grinding zone Increase coolant volume Use one grade softer wheel Use porous bond wheel Dress wheel coarser, more "open" Inspect, rotate or replace dressing tool Increase work speed Reduce stock removed per pass or upgrade to 5SG or 5NQ
Wheel loading and glazing	Wheel too fine Wheel too hard Too durable abrasive Poor coolant quality Wheel structure too closed Wheel too finely dressed Diamond dressing tool worn Depth of cut too small	Use coarser grit or softer grade wheel Use one grade softer wheel Use a sharper, more friable abrasive Change coolant or use high detergent type Use a porous bond wheel Dress wheel very open Replace diamond and dress coarse (open) Increase feed and traverse speed
Chatter	Unsupported work Machine vibration Too heavy cut rate Wheel too hard Wheel structure too closed Wheel out of balance	Increase work support Check for worn bearings Reduce cut rate Use one grade softer wheel Use a porous bond wheel Check wheel balance or try new wheel
Chatter marks on workpiece	Worn spindle bearings Wheel out of truth Poorly clamped wheel Glazed face of wheel	Check and correct for truth and end play Redress wheel and check mounting Check tightness of mounting nuts Redress wheel with sharp dressing tool
Poor surface finish	Incorrect wheel dress Worn dressing tool Too coarse grit size Wheel too hard	Dress wheel finer (slow down dressing tool traverse) Inspect, rotate, or replace dressing tool Use a finer grit size Use softer grade
Not holding form	Wheel too soft Wheel structure too open	Use one grade harder wheel Use a more closed wheel structure
Not holding corner	Incorrect wheel dress Too large grit size Wheel too soft Wheel structure too open	Dress wheel finer. Face and side true wheel Use smaller grit size (maximum grit diameter less than 1.5 times corner radius) Use harder grade wheel Use more closed structure wheel

TECHtip

WHEEL DRESSING

SINGLE POINT DIAMOND TOOLS

- Rigidly mount Single Point tools at a 10°-15° angle to the wheel centerline with a line drawn through the center of the wheel, pointing in the direction of wheel travel.
- Point of contact should be slightly below centerline of wheel.
- Use coolant whenever possible.
- Normal infeed is .001" per pass.
- Lead selections range from .002" - .010" per wheel revolution.
- Rotate the tool 1/4 turn periodically to maintain a sharp point.

MULTI-POINT DIAMOND TOOLS

- Most multi-point tools are used for straight face dressing.
- Tool should have full face contact with the wheel.
- With new tool, 3 to 5 passes at .005" per pass should be taken to expose diamonds.
- Infeed per pass .001" - .002"
- Use coolant whenever possible.
- Use appropriate lead (and traverse rate).
- Contact your Norton representative for proper tool selection for Targa wheels.

DRESSING CERAMIC WHEELS

- Use our specially designed Norton SG diamond tools when dressing ceramic wheels.
- When first using a Norton SG tool, make 3 to 5 passes at .005" infeed to ensure full face contact between the dressing tool and wheel face.
- Reduce normal dressing infeed by half. Do not exceed infeed of .002" per pass.
- The lead selection should be between .006" - .030" per wheel revolution. Faster traverse with Norton SG tools generally provides an open wheel face that can maximize productivity of the ceramic abrasive.

To optimize applications using ceramic abrasives and/or tools, normal dressing parameters must change. Reduce infeed by 25%. Significant reductions in the amount of infeed and frequency of dress will result in substantially lower cost per part ground.

See the Fliesen Tool section for new Furioso tools, engineered specifically for Quantum vitrified wheel dressing.



It is the user's responsibility to refer to and comply with ANSI B7.1

FEATURED PRODUCTS



NORTON QUANTUM (5NQ)

BEST CHOICE FOR VERSATILITY, MAXIMUM PERFORMANCE AND COST SAVINGS

FEATURES

- Revolutionary, engineered ceramic grain shape and chemistry with proven bond technology – green

BENEFITS

- Versatile; for all low, medium and high force applications ranging from cast iron, to stainless steel and hard-to-grind Inconel and titanium
- Perform well on old and new machines
- 33% to 100% longer life vs. competitive ceramic products
- 30%+ higher metal removal rate
- 15%+ lower threshold power
- Lowest total grinding costs



NORTON SG

BEST CHOICE FOR HIGH PRODUCTIVITY, LOW TOTAL PER-PART GRINDING COST

FEATURES

- Exceptionally high-performance proprietary seeded gel ceramic aluminum oxide abrasive
- Self-sharpening abrasive
- High performance VS and VSP bonds
- Provide sharp edge on tools and dies
- 5SG – Durable Norton SG and aluminum oxide blend – blue
- NORPOR 3SGR – Purple Norton SG and 48A abrasive blend with VP2 porous bond

BENEFITS

- Fast stock removal, cool, superior cutting
- 3X - 5X more life than aluminum oxide wheels
- Double rough stock removal rate versus conventional abrasives
- Less burn, less dressing; very consistent performing wheel
- Versatile; exceptional form holding
- Longer life of tools and dies in production
- High stock removal rates, excellent productivity, long wheel life, low overall grinding cost
- Maximum productivity in heat-sensitive, heavy stock removal operations



NORTON 32A

BETTER CHOICE FOR MEDIUM TO HEAVY STOCK REMOVAL

FEATURES

- Sharp monocrystalline aluminum oxide grain – the industry's most versatile abrasive – purple

BENEFITS

- Free cutting on a wide range of applications and materials
- Outstanding form holding



NORTON 38A

GOOD CHOICE FOR LIGHT GRINDING OF TOOL STEELS

FEATURES

- White, friable abrasive grain
- Consistent quality
- NORPOR 38A — White, most friable, aluminum oxide abrasive with VP2 porous bond
- Versatile

BENEFITS

- Cool and burn-free cutting; ideal for heat-sensitive applications with light to moderate feed rates
- Excellent balance and dimensional accuracy time after time
- Exceptionally cool cutting in light pressure grinding applications, or heat-sensitive applications
- Ideal for use across a broad variety of tool steels



GEMINI ALUMINUM OXIDE

GOOD CHOICE FOR USE ON GENERAL PURPOSE APPLICATIONS; ECONOMICAL

FEATURES

- Durable aluminum oxide abrasive and strong vitrified bond
- Versatile, economical

BENEFITS

- Consistent stock removing performance on narrow to medium contact areas; cool cutting
- Ideal when numerous small jobs are run on one machine
- The choice when initial price is the main purchasing criterion

ID and Race Wheels



Vitrified First Line (VFL) ID and Race Wheel availability encompasses over 1,000 wheel sizes and most abrasive types. These high-performance wheels are made-to-order and shipped within two weeks of receipt of your order.

Additional dimensions and grinding faces are available as made-to-order products with 4-week lead-times.

ID and Race Wheel FastTrack Availability

Type 01 Straight

DIAMETER: 0.164" thru 4.532" THICKNESS: 0.150" thru 2.750"

Type 05 Recessed One Side

DIAMETER: 0.407" thru 4.625" THICKNESS: 3/16" thru 3.100"

ABRASIVE	25A, 32A, 38A,	5TG**	Quantum (NQ)	32AA
	48A, 53A, 57A		1SG, 3SG, 5SG	
GRIT	46* - 120	80/1, 120/1	36 - 150	46 - 80
GRADE	J - P	I - M	I - N	I - M
STRUCTURE	6	8	6	6
BOND	VFL	VFL	VFL	VFL
SPEED	8,500 SFPM***			
TREAT 22	Available for Quantum (NQ) 32A, and 53A			

* 46 GRIT ONLY AVAILABLE IN .312 DIAMETER

** 5TG IS AVAILABLE IN /1 COMBINATION, ONLY

*** SPEEDS UP TO 12,500 SFPM BY REQUEST AND SAFETY APPROVAL

For more program details, ask your Norton sales representative to review the First Line VFL ID & Race Wheel Brochure #6981 with you.

TECHtip

WHEEL DRESSING

SINGLE POINT DIAMOND TOOLS

- Use VBE, V, VS, VK bonds for general purpose applications or medium contact areas.
- Use VBEP, VSP, VCP, VP2 bonds on wide contact areas where heat is an issue.
- Wheel dressing
 - When using a single-point diamond tool, approach the wheel at a 10°–15° angle.
 - When using a multi-point diamond tool, approach the wheel at a 0° angle.



It is the user's responsibility to refer to and comply with ANSI B7.1



High Porosity Wheels for Heat-Sensitive Applications

Norton 3SGR, 48A, 25A and 38A NorPor wheels were developed with a controlled high-porosity bond specifically for heat-sensitive applications.

- | | |
|----------------------------|--|
| • Controlled porosity bond | • Increased chip clearance and maximum coolant flow |
| | • Reduced loading |
| | • Cool cutting – wet or dry – in heat-sensitive applications |
| • Durable bond post | • Maximum grain retention |
| | • Less dressing; longer wheel life |
| • Maximum depth of cut | • Increased grain efficiency; consistent grinding action at high metal removal rates |



Vitrified Wheels For Steel Applications

AVAILABILITY



TIER: **NORTON SG** **32A** **38A / GEMINI**
 TRADENAME: Ceramic Alumina Aluminum Oxide Aluminum Oxide
 ABRASIVE:

SIZE (D X T X H)	MAX. RPM	MIN./STD. PKG.	SPEC.	PART NO.	SPEC.	PART NO.	MIN./STD. PKG.	SPEC.	PART NO.
TYPE O1 STRAIGHT									
2 x 1/2 x 3/8	16,235	20/50			32A60-KVBE	66243428214			
3 x 1/4 x 1/2	10,825	10/50			32A60-KVBE	66243528696			
3 x 1/2 x 3/8	10,825	10/50			32A60-KVBE	66243528825	10/50	38A60-JVBE	66243529032
3 x 1/2 x 1/2	10,825	10/50			32A60-KVBE	66243528828			
3 x 1 x 1/2	10,825						1/10	38A60-MVBE	66243529145
								38A80-MVBE	66243529146
4 x 1/4 x 1/2	8,120	1/10			32A60-KVBE	66243529532	1/10	38A60-KVBE	66243529777
								38A100-IVBE	66243529782
4 x 1/4 x 3/4	8,120	1/10			32A60-KVBE	66243529736			
4 x 1/2 x 1/2	8,120	1/10			32A46-KVBE	66243529845	1/10	38A60-KVBE	66243529947
								38A100-KVBE	66243529954
4 x 1/2 x 3/4	8,120	1/10			32A60-KVBE	66243529849	1/10	38A60-KVBE	66243529961
					32A80-KVBE	66243529850			
4 x 1 x 1/2	8,120						1/10	38A60-MVBE	66243530126
5 x 1/4 x 1/2	4,970	1/10			32A60-KVBE	66252830572			
6 x 1/8 x 1-1/4	4,140	1/10			32A80-KVBE	66252835361	1/10	38A150-LVBE	66252835506
6 x 1/4 x 1/2	4,140	1/10			32A60-KVBE	66252835784			
6 x 1/4 x 1-1/4	4,140	1/10			32A60-KVBE	66252835786	1/10	38A60-KVBE	66252835803
								38A80-KVBE	66252835807
								38A150-KV	66252835759
6 x 1/2 x 1/2	4,140	1/10			32A60-KVBE	66252836394	1/10	38A60-KVBE	66252836530
								38A80-KVBE	66252836548
6 x 1/2 x 1-1/4	4,140	1/10	5SG60-KVS	66252803344	32A46-KVBE	66252836380	1/10	38A46-KVBE	66252836520
					32A60-KVBE	66252836396 B		38A60-KVBE	66252836533
					32A80-JVBE	66252836405		38A80-KVBE	66252836550
								38A120-KVBE	66252836664
6 x 3/4 x 1/2	4,140	1/10			32A60-KVBE	66252837420			
6 x 3/4 x 5/8	4,140						1/10	38A60-KVBE	66252837444
6 x 3/4 x 1-1/4	4,140	1/10			32A60-KVBE	66252837421	1/10	38A60-KVBE	66252837445
6 x 1 x 1-1/4	4,140	1/10			32A60-KVBE	66252837921 B			
7 x 1/8 x 1-1/4	3,275	1/10			32A60-IVBE	66252939112	1/10	38A80-IVBE	66252939219
	3,600							38A100-KVBE	66252939223
7 x 1/4 x 1-1/4	3,600	1/10	5SG46-IVS	66252940207 B	32A46-HVBE	66252939543	1/10	38A46-HVBE	66252939690
			5SG60-IVS	66252939459 B	32A46-IVBE	66252939544		38A46-IVBE	66252939691
			5SG60-JVS	66252939460 B	32A46-JVBE	66252939545		38A46-JVBE	66252909755
			5SG60-KVS	66252939461 B	32A46-KVBE	66252939862		38A60-HVBE	66252939695
			5SG80-IVS	66252939462	32A60-HVBE	66252939547		38A60-IVBE	66252939696
			5SG80-JVS	66252939463	32A60-IVBE	66252939548 B		38A60-JVBE	66252939698
			5SG80-KVS	66252939464	32A60-JVBE	66252939549 B		38A60-KVBE	66252939700
			5SG100-JVS	66252939467	32A60-KVBE	66252939552 B		38A80-HVBE	66252939707
			5SG100-KVS	66252939468 B	32A80-HVBE	66252939557		38A80-IVBE	66252939808
					32A80-IVBE	66252939658 B		38A80-JVBE	66252939809
					32A80-JVBE	66252939660 B		38A80-KVBE	66252939812
					32A80-KVBE	66252939662 B		38A100-IVBE	66252939823
					32A100-IVBE	66252939670 B		38A100-JVBE	66252939826
					32A100-JVBE	66252939672		38A100-KVBE	66252939827
					32A100-KVBE	66252939673 B		38A100-LVBE	66252939830
					32A120-IVBE	66252939680		38A120-JVBE	66252939833
					32A120-KVBE	66252939682		38A120-KVBE	66252939834
					32A220-LVBE	66252939689		38A150-KVBE	66252939838
								38A150-LVBE	66252939839
								38A150-MV	66252939521
								38A220-KV	66252939528
								38A220-LV	66252939529
								38A220-LVBE	66252939847
								38A220-MV	66252939530
							10/10	Gemini 60-I	66253246722
								Gemini 60-J	66253246788
								Gemini 60-K	66253246789
								Gemini 80-K	66253246792

B = BEST SELLER; PERFORMS WELL IN A VARIETY OF APPLICATIONS FOR MANY SATISFIED CUSTOMERS

Vitrified Wheels For Steel Applications CONTINUED

AVAILABILITY



TIER:

BEST

BETTER

GOOD

TRADENAME:

QUANTUM / NORTON SG

32A / 48A

38A / 25A / GEMINI

ABRASIVE:

Ceramic Alumina

Aluminum Oxide

Aluminum Oxide

SIZE (D X T X H)	MAX. RPM	MIN./STD. PKG.	SPEC.	PART NO.	SPEC.	PART NO.	MIN./STD. PKG.	SPEC.	PART NO.
TYPE 01 STRAIGHT									
7 x 3/8 x 1-1/4	3,600	1/10			32A60-KVBE	66252940276	1/10	38A60-KVBE	66252940294
					32A80-KVBE	66252940284		38A80-IVBE	66252940297
7 x 1/2 x 1-1/4	3,600	1/10	5NQ46-IVS	69083159103	32A46-FVBEP	66252941203	1/10	25A46-HVP2	66252916219
			5NQ46-JVS	69083159104	32A46-GVBE	66252940862		25A60-HVP2	66252916221
			5NQ60-GVSP	69083159105	32A46-GVBEP	66252941204 B		38A46-GVBE	66252941022
			5NQ60-JVS	69083159106	32A46-HVBE	66252940863 B		38A46-GVBEP	66252941323
			3SGR46-HVP2	66252916211 B	32A46-HVBEP	66252941205 B		38A46-HVBE	66252941023
			3SGR60-HVP2	66252916213 B	32A46-IVBE	66252940864 B		38A46-HVBEP	66252941324
			5SG46-GVSP	66252940522 B	32A46-IVBEP	66252941206		38A46-HVP2	66252916223
			5SG46-HVSP	66252941130 B	32A46-JVBE	66252940865 B		38A46-IVBE	66252941024
			5SG46-IVS	66252940193 B	32A46-KVBE	66252940867 B		38A46-JVBE	66252941026
			5SG46-IVSP	66252940523	32A54-IVBE	66252940873		38A46-KVBE	66252941028
			5SG46-JVS	66252940194 B	32A60-GVBEP	66252941313		38A60-HVBE	66252941035
			5SG46-KVS	66252940195 B	32A60-HVBE	66252940879 B		38A60-HVBEP	66252941330
			5SG60-GVSP	66252940524	32A60-HVBEP	66252941314		38A60-IVBE	66252941036
			5SG60-IVS	66252940196 B	32A60-IVBE	66252940880 B		38A60-JVBE	66252941038
			5SG60-IVSP	66252940525	32A60-JVBE	66252940882 B		38A60-KVBE	66252941041
			5SG60-JVS	66252940197 B	32A60-JVBEP	66252941316		38A60-LVBE	66252911677
			5SG60-KVS	66252940198 B	32A60-KVBE	66252940885 B		38A80-HVBE	66252941047
			5SG60-LVS	66252940199	32A60-LVBE	66252940888		38A80-IVBE	66252941048
			5SG80-IVS	66252940200	32A80-HVBE	66252940894		38A80-JVBE	66252941049
			5SG80-IVSP	66252940527	32A80-IVBE	66252940895 B		38A80-KVBE	66252941054
			5SG80-JVS	66252940201 B	32A80-JVBE	66252940897 B		38A80-LVBE	66252941056
			5SG80-KVS	66252940202	32A80-KVBE	66252940899 B		38A100-IVBE	66252941163
			5SG80-LVS	66252940203	32A80-LVBE	66252940900		38A100-JVBE	66252941165
			5SG100-JVS	66252940204	32A100-IVBE	66252940907		38A100-KVBE	66252941168
			5SG100-KVS	66252940205	32A100-JVBE	66252941008		38A120-JVBE	66252941174
					32A120-LVBE	66252941018 B		38A120-KVBE	66252941175
					48A46-HVP2	66252916215 B		38A150-JVBE	66252941179
					48A60-HVP2	66252916217 B		38A150-MV	66252940595
							10/10	38A220-QV	66252940605
								Gemini 46-H	66253246795
								Gemini 46-I	66253246800
								Gemini 46-J	66253246802
								Gemini 46-K	66253246812
								Gemini 60-I	66253246818
								Gemini 60-J	66253246820
								Gemini 60-K	66253246821
								Gemini 80-K	66253246832
								Gemini 100-K	66253246838
7 x 5/8 x 1-1/4	3,600	1/10			32A60-IVBE	66252941762			
7 x 3/4 x 1-1/4	3,600	1/10	5SG46-IVS	66252942304	32A46-GVBEP	66252942070	1/10	38A46-HVBE	66252941950
			5SG46-KVS	66252942305	32A46-HVBE	66252941930		38A46-KVBE	66252941954
			5SG60-JVS	66252942307	32A46-IVBE	66252941931		38A60-IVBE	66252942207
			5SG60-KVS	66252942308	32A46-KVBE	66252941935		38A60-KVBE	66252942060
					32A60-IVBE	66252941938			
					32A60-KVBE	66252941943			
					32A80-IVBE	66252941946			
7 x 1 x 1-1/4	3,600	1/10	5SG60-JVS	66252942429	32A46-HVBE	66252942513	1/10	38A46-HVBE	66252942534
			5SG60-KVS	66252942430	32A46-JVBE	66252942268			
					32A60-IVBE	66252942524			
					32A60-KVBE	66252942709			

B = BEST SELLER; PERFORMS WELL IN A VARIETY OF APPLICATIONS FOR MANY SATISFIED CUSTOMERS

For non-stock toolroom wheels: if you don't see the toolroom wheel you need in our stock listing, call your local authorized Norton distributor to check our made-to-order non-stock availability – including our revolutionary new Quantum ceramic wheels.

Vitrified Wheels For Steel Applications CONTINUED

AVAILABILITY



TIER:	BEST	BETTER	GOOD
TRADENAME:	NORTON SG	32A / 48A	38A / 57A
ABRASIVE:	Ceramic Alumina	Aluminum Oxide	Aluminum Oxide

SIZE (D X T X H)	MAX. RPM	MIN./STD. PKG.	SPEC.	PART NO.	SPEC.	PART NO.	MIN./STD. PKG.	SPEC.	PART NO.
TYPE 01 STRAIGHT									
8 x 1 x 1-1/4	+	1/10	5SG46-KVS	66253002588	32A46-HVBE	66253044616	1/10	38A46-IVBE	66253044636
	+		5SG60-GVSP	66253003228†	32A46-IVBE	66253044617		38A60-IVBE	66253044456
	3,600		5SG60-IVS	66253002639	32A46-KVBE	66253044622		57A60-MVBE	66253044270
	3,600				32A60-IVBE	66253044624			
	3,600				32A60-KVBE	66253044629			
10 x 1/4 x 3	2,485						1/-	38A80-KVBE	66253149572
10 x 1/2 x 3	2,485	2/-			32A60-JVBE	66253149729	1/-	38A60-KVBE	66253149859
								38A80-KVBE	66253149865
10 x 3/4 x 3	2,485	1/-			32A46-IVBE	66253160024	1/-	38A46-JVBE	66253160158
					32A60-IVBE	66253160137		38A60-IVBE	66253160163
					32A60-KVBE	66253160143			
10 x 1 x 1-1/4	2,485	1/-			32A60-KVBE	66253160774			
10 x 1 x 2	2,485	1/-			32A46-IVBE	66253160749			
10 x 1 x 3	2,485	1/-	5SG46-GVSP	66253160494	32A46-HVBE	66253160747	1/-	38A46-IVBE	66253160889
			5SG46-IVS	66253160400	32A46-IVBE	66253160750		38A46-JVBE	66253160892
			5SG46-JVS	66253160401	32A46-JVBE	66253160754		38A60-IVBE	66253160898
			5SG46-KVS	66253160402	32A46-KVBE	66253160758		38A60-KVBE	66253160900
			5SG60-GVSP	66253160495	32A60-IVBE	66253160769			
			5SG60-IVS	66253160403	32A60-KVBE	66253160777			
			5SG60-JVS	66253160404	32A80-KVBE	66253160782			
			5SG60-KVS	66253160405					
12 x 1/2 x 3	2,070	2/-			32A60-JVBE	66253262134			
					32A80-KVBE	66253262110			
12 x 1/2 x 5	2,070	2/-			32A60-KVBE	66253262107			
					32A80-KVBE	66253262111			
12 x 3/4 x 3	2,070	1/-	5SG46-IVS	66253262204	32A46-GVBEP	66253262392	1/-	38A46-JVBE	66253262281
					32A46-HVBE	66253262260			
					32A46-IVBE	66253262261			
					32A60-IVBE	66253262270			
					32A60-KVBE	66253262273			
12 x 1 x 1-1/4	2,070	1/-			32A46-KVBE	66253262570			
12 x 1 x 3	•	1/-	3SGR46-HVP2	66253220885	32A46-GVBEP	66253262840	1/-	38A46-HVBE	66253262700
	2,070		5SG46-HVSP	66253262488	32A46-HVBE	66253262562		38A46-IVBE	66253262702
	2,070		5SG46-IVS	66253262500	32A46-HVBEP	66253262842		38A46-JVBE	66253262704
	2,070		5SG46-JVS	66253262501	32A46-IVBE	66253262564		38A60-IVBE	66253262713
	2,070		5SG46-KVS	66253262502	32A46-JVBE	66253262567			
	2,070		5SG60-GVSP	66253262593	32A46-KVBE	66253262572			
	2,070		5SG60-IVS	66253262503	32A60-HVBE	66253262580			
	2,070		5SG60-JVS	66253262504	32A60-IVBE	66253262581			
	2,070		5SG60-KVS	66253262505	32A60-KVBE	66253262689			
	2,070				32A80-KVBE	66253262532			
	2,710				48A60-HVP2	66253220891			
12 x 1 x 5	2,070	1/-	5SG46-GVSP	66253262594	32A46-GVBEP	66253262841	1/-	38A46-IVBE	66253262703
			5SG46-IVS	66253262508	32A46-HVBE	66253262563		38A60-KVBE	66253262719
			5SG46-JVS	66253262509 B	32A46-IVBE	66253262565			
			5SG46-KVS	66253262510	32A46-KVBE	66253262573			
			5SG60-GVSP	66253262595	32A60-HVBE	66253262734			
			5SG60-IVS	66253262511	32A60-IVBE	66253262582			
			5SG60-JVS	66253262512	32A60-JVBE	66253262686			
			5SG60-KVS	66253262513	32A60-KVBE	66253262691 B			
			5SG80-JVS	66253262515	32A80-JVBE	66253262696			
					32A80-KVBE	66253262697			
12 x 1-1/4 x 3	2,070	1/-			32A46-IVBE	66253262301			
12 x 1-1/2 x 1-1/4	2,070	1/-			32A46-KVBE	66253263146			
12 x 1-1/2 x 3	2,070	1/-	5SG46-IVS	66253202820	32A46-HVBE	66253263143			
					32A46-IVBE	66253263144			
					32A60-IVBE	66253263123			

+ † REFER TO THE TECH TIPS AT THE BOTTOM OF THE PREVIOUS PAGE
 • 12" TYPE 01 WHEEL MAXIMUM RPM: NORPOR WHEELS = 2,710; ALL OTHERS = 2,070
 B = BEST SELLER; PERFORMS WELL IN A VARIETY OF APPLICATIONS FOR MANY SATISFIED CUSTOMERS

Vitrified Wheels For Steel Applications CONTINUED

AVAILABILITY



BEST



BETTER



GOOD

TIER:

TRADENAME:

ABRASIVE:

QUANTUM / NORTON SG

Ceramic Alumina

32A

Aluminum Oxide

38A / 57A

Aluminum Oxide

SIZE (D X T X H)	MAX. RPM	MIN./STD. PKG.	SPEC.	PART NO.	SPEC.	PART NO.	MIN./STD. PKG.	SPEC.	PART NO.
TYPE O1 STRAIGHT									
12 x 1-1/2 x 5	2,070	1/-	5NQ46-IVS	69083159115	32A46-GVBEP	66253263192	1/-	38A46-IVBE	66253214987
			5NQ46-JVS	69083159116	32A46-HVBE	66253263128			
			5NQ60-GVSP	69083159117	32A46-IVBE	66253263145			
			5NQ60-JVS	69083159118	32A46-JVBE	66253263120			
			5SG46-GVSP	66253203453	32A60-HVBE	66253263149			
			5SG46-IVS	66253202842	32A60-KVBE	66253263034			
			5SG46-JVS	66253202926					
			5SG60-GVSP	66253262596					
12 x 2 x 1-1/4	2,070	1/-			32A46-KVBE	66253263461			
					32A46-MVBE	66253263463			
12 x 2 x 3	2,070	1/-			32A46-IVBE	66253263459			
12 x 2 x 5	2,070	1/-			32A46-HVBE	66253263403			
					32A46-IVBE	66253262302			
					32A60-KVBE	66253263465			
14 x 1/2 x 5	1,800	1/-	5SG80-KVS	66253363814	32A60-KVBE	66253363761			
14 x 3/4 x 5	1,800	1/-			32A60-KVBE	66253363772			
14 x 1 x 3	1,800	1/-	5SG46-IVS	66253363960	32A46-HVBE	66253363912			
			5SG46-KVS	66253363961	32A46-IVBE	66253363914			
					32A46-JVBE	66253363917			
					32A60-IVBE	66253363927			
14 x 1 x 5	1,800	1/-	5SG46-GVSP	66253364108	32A46-GVBEP	66253364074	1/-	38A46-HVBE	66253364043
			5SG46-HVSP	66253313990	32A46-HVBE	66253363913		38A60-IVBE	66253363947
			5SG46-IVS	66253363970	32A46-IVBE	66253363915		38A60-JVBE	66253364051
			5SG46-JVS	66253363971	32A46-JVBE	66253363919		38A60-KVBE	66253364053
			5SG60-IVS	66253363974	32A46-KVBE	66253363921		38A80-KVBE	66253364058
			5SG60-IVSP	66253363871	32A60-GVBEP	66253364077		57A60-KVBE	66253364065
			5SG60-JVS	66253363975	32A60-HVBE	66253363926		57A60-LVBE	66253364066
			5SG60-KVS	66253363976	32A60-JVBE	66253363930		57A80-MVBE	66253364070
			5SG80-JVS	66253363979	32A60-KVBE	66253363932			
			5SG80-KVS	66253364003	32A60-LVBE	66253364035			
					32A80-JVBE	66253364038			
					32A80-KVBE	66253364039			
14 x 1 x 8	1,800	1/-			32A60-IVBE	66253363887			
14 x 1-1/2 x 5	1,800	1/-	5NQ46-IVS	69083159119	32A46-GVBEP	66253364238	1/-	38A46-HVBE	66253313968
			5NQ46-JVS	69083159120	32A46-HVBE	66253364335 B		38A46-HVBEP	66253313969
			5NQ60-GVSP	69083159122	32A46-HVBEP	66253364243		38A46-IVBE	66253364090
			5NQ60-JVS	69083159124	32A46-IVBE	66253364336		38A46-JVBE	66253364240
			5SG46-GVSP	66253364320	32A46-JVBE	66253364337		38A60-IVBE	66253364247
			5SG46-HVSP	66253302625	32A46-KVBE	66253364339			
			5SG46-IVS	66253364097 B	32A60-HVBE	66253364340			
			5SG46-IVSP	66253302498	32A60-IVBE	66253364239			
			5SG46-JVS	66253364098 B	32A60-JVBE	66253364341			
			5SG60-IVS	66253364100	32A60-KVBE	66253364342			
			5SG60-JVS	66253364101	32A80-JVBE	66253364246			
			5SG60-KVS	66253302160					
			5SG80-KVS	66253363815					
14 x 2 x 5	1,800	1/-	5SG60-JVS	66253364414	32A46-IVBE	66253364323			
					32A46-JVBE	66253364508			
					32A46-KVBE	66253364509			
					32A60-KVBE	66253364510			

B = BEST SELLER; PERFORMS WELL IN A VARIETY OF APPLICATIONS FOR MANY SATISFIED CUSTOMERS

DRESSING: SINGLE POINT DRESSING TOOL STARTING RECOMMENDATIONS

WHEEL SIZES	TOOL SHANK DIAMETER	CERAMIC (NQ, NORTON SG, TG, ETC.), 37C & 39C WHEELS PRODUCT NO. PART NO.	25A, 32A, 38A, 48A, 53A, 57A, 64A, 86A WHEELS PRODUCT NO. PART NO.
12" to 14"	3/8	BCSG5M6 66260157009	BC5M6 66260195004
	7/16	BCSG5M7 66260156907	BC5M7 66260195005

THESE TOOLS ARE A STANDARD RECOMMENDATION; SEE THE "DIAMOND TOOL" SECTION FOR ADDITIONAL TOOLS

SEE THE FLEISEN TOOL SECTION FOR NEW FURIOSO TOOLS, ENGINEERED SPECIFICALLY FOR QUANTUM VITRIFIED WHEEL DRESSING

Vitrified Wheels For Steel Applications CONTINUED

AVAILABILITY



TIER:

BEST

BETTER

GOOD

TRADENAME:

NORTON SG

32A / 23A

38A / 53A / 57A

ABRASIVE:

Ceramic Alumina

Aluminum Oxide

Aluminum Oxide

SIZE (D X T X H)	MAX. RPM	MIN./STD. PKG.	SPEC.	PART NO.	SPEC.	PART NO.	MIN./STD. PKG.	SPEC.	PART NO.
TYPE O2 CYLINDER									
6 x 1 x 4 Rim 1" Plate A47466	3,600	1/10			32A46-KVBE 32A60-JVBE	66252838308 66252838309	1/10	38A80-HVBE	66252838314
6 x 3-7/8 x 4-7/8 Used in Pairs Rim 9/16" (ME159035) Plate A308567	3,600						2/-	46-K+ Knife Sharpening	66253049501
8 x 2 x 5-1/2 Rim 1-1/4" Plate A50831	2,865						1/8	53A46-KVBE	66253044942
8 x 3-1/2 x 6-1/2 Used in Pairs Rim 3/4" (ME151086) Plate A76209	4,060						2/-	57A54-K+8VBE	66253038939
10 x 2 x 7-1/2 Rim 1-1/4" (ME62845) Plate A110170	2,295	1/-			32A54-JVG	66253161687	1/-	53A60-KVG	66253161701
11 x 5 Rim 1" (ME33437) Tape Wound	1,910	1/-			32A30-HVBE	66253161800			
11 x 5 Rim 1" (ME52726) Tape Wound	1,740 1,910	1/-			32A36-EVBEP 32A36-GVBEP 32A46-HVBE	66253161780 66253161808 66253161893	1/-	38A46-GVBE	66253161807
14 x 4 x 11 Rim 1-1/2" (ME62806) Plate A52814 Tape Wound	1,640						1/-	38A46-KVBE	66253364652
18 x 5 Rim 1-1/2" (ME15536) Tape Wound	1,065	1/-			32A30-E19VCP	66253465142			
18 x 5 Rim 1-1/2" (ME52719) Tape Wound Includes Strips	1,170	1/-			23A30-F19VCP 23A30-G19VCP	66253465235 66253465129			
20 x 5 Rim 1-3/4" (ME58559) Tape Wound Includes Strips	1,050	1/-			23A30-G19VCP	69078665769			
TYPE O5 RECESSED ONE SIDE									
3/4 x 3/4 x 1/4 Recess 1/S 3/8 x 3/8	43,290	15/40			32A60-KVBE	66243427582			
1 x 1 x 1/4 Recess 1/S 1/2 x 1/2	32,470	15/40			32A60-KVBE	66243427769			
1 x 1 x 3/8 Recess 1/S 1/2 x 1/2	32,470	15/40			32A60-KVBE	66243427773			
1-1/4 x 1 x 3/8 Recess 1/S 5/8 x 1/2	25,975	15/40			32A60-KVBE	66243427799			
1-1/2 x 1 x 3/8 Recess 1/S 5/8 x 1/2	25,975	15/40			32A60-KVBE	66243427938			

For non-stock toolroom wheels: if you don't see the toolroom wheel you need in our stock listing, call your local authorized Norton distributor to check our made-to-order non-stock availability – including our revolutionary new Quantum ceramic wheels.

Vitrified Wheels For Steel Applications CONTINUED

AVAILABILITY



TIER:	BEST	BETTER	GOOD
TRADENAME:	NORTON SG	32A / 48A	38A / GEMINI
ABRASIVE:	Ceramic Alumina	Aluminum Oxide	Aluminum Oxide

SIZE (D X T X H)	MAX. RPM	MIN./STD. PKG.	SPEC.	PART NO.	SPEC.	PART NO.	MIN./STD. PKG.	SPEC.	PART NO.
TYPE 05 RECESSED ONE SIDE									
1-1/2 x 1 x 3/8	21,645	15/40			32A60-KVBE	66243427937			
Recess 1/5 3/4 x 1/2									
2 x 1 x 3/8	16,235	15/40			32A60-KVBE	66243428329			
Recess 1/5 3/4 x 1/2									
2 x 1-1/2 x 5/8	16,235	10/15			32A60-KVBE	66243428332			
Recess 1/5 1 x 3/4									
7 x 3/4 x 1-1/4	3,600	1/10	5SG46-IVS	66252941976	32A46-HVBE	66252942209	1/10	38A46-IVBE	66252942222
Rec 1/5 2-3/4 x 1/4			5SG60-IVS	66252942312	32A46-IVBE	66252942211		38A60-IVBE	66252942225
					32A46-JVBE	66252942213			
					32A60-IVBE	66252942217			
					32A60-JVBE	66252942218			
					32A60-KVBE	66252942205			
7 x 3/4 x 1-1/4	3,600						10/10	Gemini 46-J	66253246826
Rec 1/5 3 x 1/4								Gemini 60-J	66253246830
7 x 1 x 1-1/4	3,600	1/10	3SGR46-HVP2	66252916228	32A46-GVBEP	66252942826			
Rec 1/5 2-3/4 x 1/2			5SG46-IVS	66252942318	32A46-HVBE	66252942688			
			5SG46-JVS	66252942427	32A46-HVBEP	66252942828			
			5SG60-JVS	66252942431	32A46-IVBE	66252942691			
					32A46-KVBE	66252942708			
					32A60-IVBE	66252942699			
					32A60-JVBE	66252942701			
					32A60-KVBE	66252942703			
					48A46-HVP2	66252916232			
7 x 1 x 1-1/4	3,600	1/10	5SG46-IVS	66252901814	32A46-HVBE	66252942689	1/10	38A46-HVBE	66252942707
Rec 1/5 3 x 1/2			5SG60-IVS	66252906907	32A46-IVBE	66252942690		38A46-IVBE	66252942809
					32A60-IVBE	66252942686		38A46-KVBE	66252942793
								38A60-IVBE	66252942815
								38A60-JVBE	66252942816
								38A60-KVBE	66252942817
							10/10	Gemini 46-H	66253246831
								Gemini 46-J	66253246835
								Gemini 60-J	66253246839
7 x 1-1/4 x 1-1/4	3,600	1/5			32A46-HVBE	66252942833			
Rec 1/5 2-3/4 x 5/8					32A60-IVBE	66252942859			
					32A60-JVBE	66252942835			
7 x 1-1/2 x 1-1/4	3,600	1/5			32A46-IVBE	66252942843			
Rec 1/5 2-3/4 x 3/4					32A60-IVBE	66252942844			
8 x 3/4 x 1-1/4	3,105	1/10			32A46-IVBE	66253044213			
Rec 1/5 3-1/4 x 1/4									
8 x 1 x 1-1/4	3,105						10/10	Gemini 46-H	66253246849
Rec 1/5 3 x 1/2	3,600							Gemini 46-J	66253246850
8 x 1 x 1-1/4	3,105	1/10	5SG46-IVS	66253013543	32A46-IVBE	66253044790			
Rec 1/5 3-1/4 x 1/2	3,600		5SG46-JVS	66253003301	32A46-JVBE	66253044382			
	3,600				32A60-IVBE	66253044753			
	3,600				32A60-KVBE	66253044810			
10 x 3/4 x 2	2,485	1/-			32A60-JVBE	66253160189			
Rec Side A									
5 x 3/16 Face Bev									
Side A 75 Deg									
From 1/8" Flat									
12 x 1-1/2 x 3	2,070	1/-			32A46-IVBE	66253263186			
Rec 1/5 6 x 1/2									
12 x 1-1/2 x 5	•	1/-	3SGR46-HVP2	66253220904	32A46-HVBEP	66253263180	1/-	38A46-IVBE	66253263175
Rec 1/5 7-1/2 x 1/2	2,070		5SG46-GVSP	66253263127	32A46-IVBE	66253263166			
	2,070		5SG46-IVS	66253202883	32A46-JVBE	66253263169			
	2,070		5SG60-IVSP	66253263050	32A46-KVBE	66253263170			
	2,070				32A60-KVBE	66253263172			

• 12" TYPE 05 WHEEL MAXIMUM RPM: NORPOR VP2 WHEELS = 2,710; ALL OTHERS = 2,070

Vitrified Wheels For Steel Applications CONTINUED

AVAILABILITY



TIER:	BEST	BETTER	GOOD
TRADENAME:	NORTON SG	32A / 48A	38A / 25A / 53A
ABRASIVE:	Ceramic Alumina	Aluminum Oxide	Aluminum Oxide

SIZE (D X T X H)	MAX. RPM	MIN./STD. PKG.	SPEC.	PART NO.	SPEC.	PART NO.	MIN./STD. PKG.	SPEC.	PART NO.
TYPE 05 RECESSED ONE SIDE									
14 x 1-1/2 x 5	•	1/-	3SGR46-GVP2	66253319953	32A46-HVBE	66253364359			
Rec 1/S 8 x 1/2	•		3SGR46-HVP2	66253319954	32A46-IVBE	66253364300			
	•		3SGR60-HVP2	66253319956	32A46-KVBE	66253364362			
	1,800		5SG46-IVS	66253364102	32A60-JVBE	66253364364			
	1,800		5SG46-JVS	66253364103	32A60-KVBE	66253364365			
	•		5SG60-IVS	66253364104	48A46-HVP2	66253319958			
	1,800		5SG60-JVS	66253364105					
14 x 2 x 5	2,320	1/-	3SGR46-GVP2	66253319936	48A46-HVP2	66253319941	1/-	25A46-HVP2	66253319945
Rec 1/S 8 x 1/2			3SGR46-HVP2	66253319937				38A46-HVP2	66253319949
								38A60-HVP2	66253319951
14 x 2 x 5	1,800	1/-			32A60-KVBE	66253364390			
Rec 1/S 8 x 1					32A60-LVBE	66253364525			
TYPE 06 STRAIGHT CUP									
3-1/2 x 1-1/2 x 1/2	6,550						1/10	38A60-KVBE	66243529372
Rim 1/2" Back 1/2"									
100mm x 50mm	6,550						1/10	38A80-JVBE	66243530429
x 20mm									
Rim 10mm									
Back 13mm									
4 x 1-1/2 x 1/2	5,730	1/10			32A60-KVBE	66243530218			
Rim 1/2" Back 1/2"									
4 x 1-1/2 x 1-1/4	5,730						1/10	38A60-KVBE	66243530221
Rim 1/2" Back 1/2"									
4 x 2 x 20mm	5,730						1/10	38A80-JVBE	66243530523
Rim 3/8" Back 1/2"									
5 x 1-1/2 x 1-1/4	4,585	1/10			32A46-KVBE	66252830832	1/10	38A46-KVBE	66252830842
Rim 3/8" Back 3/8"					32A60-JVBE	66252830837		38A60-KVBE	66252830846
Face Y (ME19243)					32A60-KVBE	66252830838			
5 x 2 x 5/8	4,585	1/10			32A60-JVBE	66252830987			
Rim 1/2" Back 1/2"									
6 x 1-1/2 x 1/2	3,820	1/10			32A46-KVBE	66252838458			
Rim 1" Back 1/2"									
6 x 2 x 1-1/4	3,820	1/10			32A46-IVBE	66252838544	1/10	38A60-KVBE	66252838486
Rim 1/2" Back 1/2"					32A60-JVBE	66252838538			
7 x 2 x 1-1/4	3,275	1/8			32A46-JVBE	66252942856			
Rim 1/2" Back 1/2"									
9-1/2 x 1-1/2 x 1-1/2	2,415						1/-	53A46-LVBE	66253149136
Rim 1-1/2" Back 5/8"									
12 x 2-1/2 x 7	1,910	1/-			32A46-LVBE	66253263614			
Rim 1-1/2" Back 7/8"									
TYPE 07 RECESSED TWO SIDES									
12 x 2 x 3	2,070	1/-			32A46-IVBE	66253263588			
Rec 2/S 5-1/2 x 3/8									
12 x 2 x 3	2,070	1/-			32A46-HVBE	66253263590			
Rec 2/S 7-1/4 x 1/2					32A46-JVBE	66253263348			
12 x 2 x 5	2,070	1/-			32A46-IVBE	66253263594			
Rec 2/S 7-1/4 x 1/2									
12 x 2 x 5	2,070	1/-	5SG46-JVS	66253209930	32A46-HVBE	66253263591	1/-	38A46-IVBE	66253263600
Rec 2/S 7-1/2 x 1/2					32A46-HVBEP	66253263603			
					32A46-JVBE	66253263483			
					32A46-KVBE	66253263596			
					32A60-IVBE	66253263597			

• 14" TYPE 05 WHEEL MAXIMUM RPM: NORPOR VP2 WHEELS = 2,320; ALL OTHERS = 1,800

Vitrified Wheels For Steel Applications CONTINUED

AVAILABILITY







TRADENAME:
ABRASIVE:

NORTON SG
Ceramic Alumina

32A
Aluminum Oxide

38A
Aluminum Oxide

SIZE (D X T X H)	MAX. RPM	MIN./STD. PKG.	SPEC.	PART NO.	SPEC.	PART NO.	MIN./STD. PKG.	SPEC.	PART NO.
TYPE 11 FLARING CUP 									
3/2-1/4 x 1-1/4 x 3/4 Rim 1/4" Back 3/8" Face Z (ME21560)	7,640	1/10			32A60-JVBE 32A60-KVBE	66243529183 66243529187	1/10	38A60-JVBE	66243529197
3-1/2/2-3/4 x 1-1/2 x 1-1/4 Rim 1/4" Back 3/8" Face Z (ME24327)	7,640	1/10			32A60-KVBE	66243529358			
4/3 x 1-1/2 x 1-1/4 Rim 1/4" Back 1/2" Face Z (ME19237)	5,730	1/10	5SG46-IVSP 5SG46-KVS 5SG60-JVS 5SG60-LVS 5SG80-JVS 5SG80-KVS	66243530127 66243503342 66243530415 66243530417 66243530419 66243530420	32A46-IVBE 32A46-KVBE 32A60-JVBE 32A60-KVBE 32A80-KVBE	66243530240 66243530246 66243530256 66243530361 66243530368	1/10	38A46-KVBE 38A60-JVBE 38A60-KVBE 38A80-JVBE 38A80-KVBE	66243530378 66243530387 66243530390 66243530393 66243530395
4-1/2/3-3/4 x 2 x 1-1/4 Rim 1/4" Back 1/2" (ME20115)	5,730	1/10			32A46-KVBE	66252830539			
5/3-3/4 x 1-3/4 x 1-1/4 Rim 1/4" Back 1/2" Face Z (ME21563)	4,585	5/5	5SG46-KVS 5SG60-KVS 5SG60-LVS	66252803291 66252830737 66252830736	32A46-JVBE 32A46-KVBE 32A60-JVBE 32A60-KVBE 32A80-KVBE	66252830858 66252830859 66252830962 66252830964 66252830966	5/5	38A46-KVBE 38A60-JVBE 38A60-KVBE	66252830971 66252830973 66252830975
6/4-1/2 x 2 x 1-1/4 Rim 3/8" Back 1/2" Face Z (ME19241)	3,820	5/5			32A46-JVBE 32A46-KVBE 32A60-JVBE 32A60-KVBE	66252838491 66252838528 66252838492	5/5	38A46-KVBE 38A60-KVBE	66252838495 66252838497
7/5 x 2 x 1-1/4 Rim 3/4" Back 1/2" (ME19242)	3,275	1/8			32A46-JVBE	66252942959	1/8	38A46-HVBE	66252942963
TYPE 12 DISH 									
4 x 1/2 x 3/4 (ME19226)	6,207	1/10			32A60-KVBE	66243530067			
6 x 1/2 x 1-1/4 (ME19229)	4,140	1/10	5SG60-LVS	66252836574	32A46-JVBE 32A60-JVBE	66252836860 66252836966	1/10	38A60-JVBE	66252836977
6 x 3/4 x 1-1/4 (ME19230)	4,140	1/10	5SG60-KVS	66252837771	32A46-KVBE 32A60-JVBE 32A60-KVBE	66252837732 66252837734 66252837735			
7 x 1/2 x 1-1/4 (ME13717)	3,600	1/10			32A46-KVBE 32A60-KVBE	66252941644 66252941647			
8 x 3/4 x 1-1/4 (ME19231)	3,600						1/10	38A60-KVBE	66253044319
10 x 1 x 1 (ME38702)	2,485	1/-			32A54-JVBE	66253161196			
10 x 1 x 1-1/4 (ME38702)	2,485	1/-			32A54-JVBE	66253161197			
TYPE 20 CONCAVE ONE SIDE 									
14 x 1-1/2 x 5 Concave from Periphery 1/2" Deep to 8" Flat Spot	1,800	1/-	5SG60-JVS	66253302265	32A60-JVBE 32A60-KVBE 32A60-LVBE	66253364250 66253364332 66253364375			
TYPE 35 PLATE MOUNTED DISC 									
9 x 2 x 4-15/16 Rim 2-1/32" (ME31130) Plate A47248	2,550	1/-			32A46-MVBE 32A60-J25VCF2 32A70-JVBEP	66253049115 66253006557 66253049112			



CATEGORY DEFINITION

These sharp silicon carbide, vitrified wheels are used for grinding non-steel applications.

APPLICATIONS: Use 39C (green silicon carbide) for cemented carbides, titanium, metal matrix composites and plasma sprayed materials.

Use 37C (black silicon carbide) on 300 series stainless steels, irons, nonferrous metals (aluminum, brass, bronze and copper) and non-metallic materials (stone, marble, rubber, ceramics and glass).

SHAPES: Type 01 Straight, Type 02 Cylinder, Type 05 Recessed 1 Sides, Type 06 Straight Cup

SIZE RANGE: 2" – 14" diameter

GRIT RANGE: 24 – 120

ABRASIVE GRAIN: 39C Green Silicon Carbide, 37C Black Silicon Carbide

Vitrified Wheels For Non-Steel Applications

AVAILABILITY

TIER: **GOOD**

TRADENAME: **39C / 37C**
ABRASIVE: Silicon Carbide

SIZE (D X T X H)	MAX. RPM	MIN./STD. PKG.	SPEC.	PART NO.
TYPE 01 STRAIGHT				
3 x 1/2 x 1/2	10,825	10/50	37C60-MVK	66243529041
3 x 1 x 1/2	10,825	1/30	37C60-MVK	66243529166
			37C80-HVK	66243529170
			37C80-MVK	66243529171
			37C100-HVK	66243529172
			37C100-MVK	66243529070
3-1/2 x 1-1/2 x 7/8 (ME622)	7,095	1/10	37C24-SVK	66243529339
			37C30-SVK	66243529338
4 x 1/2 x 1/2	8,120	1/10	37C60-MVK	66243529960
			39C100-IVK	66243530064
6 x 1/2 x 1-1/4	4,140	1/10	39C60-IVK	66252836706
			39C80-IVK	66252836816
			39C100-IVK	66252836827
			39C120-IVK	66252836836
6 x 3/4 x 1-1/4	4,140	1/10	39C60-IVK	66252837584
			39C80-IVK	66252837598
			39C100-IVK	66252837717
6 x 1 x 1-1/4	4,140	1/10	39C60-IVK	66252838161
			39C80-IVK	66252838173
7 x 1/4 x 1-1/4	3,600	1/10	39C80-JVK	66252940007
			39C100-IVK	66252940109
			39C120-IVK	66252940111
7 x 1/2 x 1-1/4	3,600	1/10	37C46-JVK	66252941488
			37C60-OVK	66252941498
			39C60-IVK	66252941609
			39C60-JVK	66252941611
			39C60-KVK	66252941613
			39C80-IVK	66252941617
			39C80-JVK	66252941618
			39C100-HVK	66252941622
			39C100-IVK	66252941624
			39C120-IVK	66252941632 B
			39C120-IVK	66252941632 B
7 x 3/4 x 1-1/4	3,600	1/10	39C80-JVK	66252942096
			39C100-JVK	66252942104
			39C60-IVK	66252942666
7 x 1 x 1-1/4	3,600	1/10	39C80-IVK	66252942413
			39C120-IVK	66252942416
			39C60-IVK	66253044013
8 x 1/2 x 1-1/4	3,600	1/10	39C100-IVK	66253044017 B
			39C60-JVK	66253044312
			39C100-IVK	66253044314
8 x 3/4 x 1-1/4	3,600	1/10	39C60-JVK	66253044770
			39C80-IVK	66253044425 B
			39C100-IVK	66253044379

AVAILABILITY

TIER: **GOOD**

TRADENAME: **39C / 37C**
ABRASIVE: Silicon Carbide

SIZE (D X T X L)	MAX. RPM	MIN./STD. PKG.	SPEC.	PART NO.
TYPE 01 STRAIGHT				
10 x 1 x 3	2,485	1/-	39C60-JVK	66253160348
10 x 1-1/2 x 2	2,485	1/-	39C60-JVK	66253161640
12 x 1 x 3	2,070	1/-	39C60-IVK	66253262985
			39C60-IVK	66253262884
12 x 1 x 5	2,070	1/-	39C80-JVK	66253262988
			39C60-JVK	66253364206
14 x 1 x 5	1,800	1/-	39C80-JVK	66253364208
			39C60-JVK	66253364242
14 x 2 x 5	1,800	1/-	39C60-JVK	66253364322
			39C60-JVK	66253364322
TYPE 02 CYLINDER				
6 x 1 x 4 Rim 1" Plate A47466	3,600	1/10	39C60-IVK	66252838322
			39C60-IVK	66252838324
			39C80-IVK	66252838327
			39C100-IVK	66252838330
6 x 1-1/4 x 4 Rim 1" Plate A47466	3,600	1/10	39C120-IVK	66252838193
			39C60-IVK	66252838345
7 x 1-1/2 x 5 Rim 1" Plate A39027	3,600	1/8	39C60-IVK	66252942848
			39C60-HVK	66253161675
			39C60-JVK	66253161678
10 x 2 x 7 Rim 1-1/2" Plate A83831	2,295	1/-	39C120-IVK	66253161784
			39C60-JVK	66253364657
14 x 4 x 11 Rim 1-1/2" Plate A52814 Tape Wound	1,640	1/-	39C60-IVK	66253364657
			39C60-IVK	66253364657
TYPE 05 RECESSED ONE SIDE				
14 x 1-1/2 x 5 Rec 1/8 x 1/2	1,800	1/-	39C60-IVK	66253364328
TYPE 06 STRAIGHT CUP				
2 x 1 x 1/4 Rim 5/16" Back 3/8"	11,460	15/40	37C120-K8V	66243428319

B = BEST SELLER; PERFORMS WELL IN A VARIETY OF APPLICATIONS FOR MANY SATISFIED CUSTOMERS

LARGE SURFACE GRINDING WHEELS

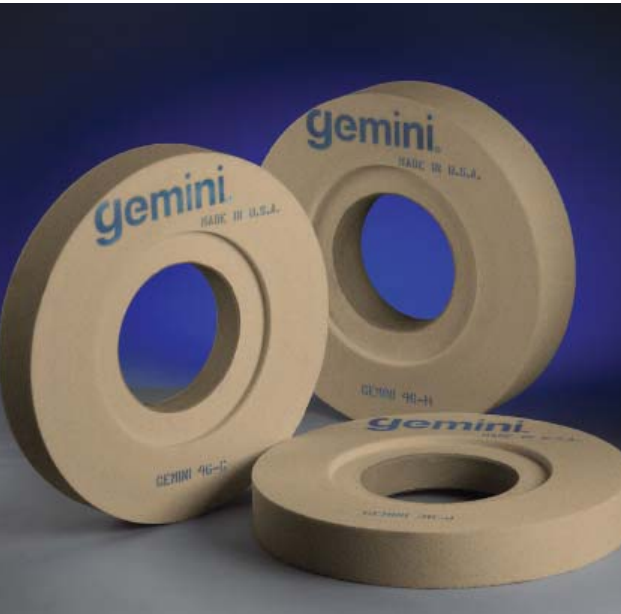

CATEGORY DEFINITION

Large surface grinding wheels are generally used to grind flat stock or flat surfaces within a workpiece. These wheels are typically used on horizontal spindle machines. Applications can vary from heavy, rapid stock removal to precision tolerance operations.

APPLICATIONS:	<ul style="list-style-type: none"> • Producing flat stock • Grinding large molds and dies • Sharpening knives, blades and cutlery • Manufacturing broaches
SHAPE:	Type 07 Recessed 2 Sides
SIZE RANGE:	Stock: 20" diameter 2" – 6" thickness
ABRASIVE GRAIN:	Aluminum Oxide

CROSS REFERENCE GUIDE

NORTON

GOOD
Gemini

Camel	91A
Cincinnati Milacron	29A, 97A
Radiac	WAA, 97A, 45A

FEATURED PRODUCTS

GEMINI WHEELS

GOOD CHOICE WHEN A BROAD RANGE OF PARTS ARE GROUND ON ONE MACHINE

FEATURES	BENEFITS
• Specially blended aluminum oxide abrasive for many surface grinding applications	• Consistent performance at an economical price • Faster grinding rates remove stock; lower rates produce finer finishes
• Porous bond	• Cool cutting on medium to wide contact areas; high chip clearance and stock removal
• Versatile	• Ideal when a broad range of tool steel parts are ground on one machine

AVAILABILITY

TIER: **GOOD**

TRADENAME: **GEMINI**

ABRASIVE: Aluminum Oxide

SIZE (D X T X H)	MAX. RPM	STD. PKG.	SPEC.	PART NO.
TYPE 07 RECESSED TWO SIDES 				
20 x 2 x 8 Recess 2/S 11-1/2 x 1/2	1,625	1	Gemini 59A46-I Gemini 46-G	66253246949 66253246953
20 x 3 x 8 Recess 2/S 11-1/2 x 1/2	1,625	1	Gemini 46-G Gemini 46-H	66253246972 66253246969
20 x 3 x 10 Recess 2/S 12-1/4 x 3/4	1,625	1	Gemini 59A46-I	66253058315
20 x 3 x 10 Recess Side A 12-1/2 x 1	1,625	1	Gemini 36-J Gemini 46-D	66253246980 66253246988
20 x 3 x 10 Recess Side B 12-1/2 x 1/2	1,625	1	Gemini 46-H	66253246991
20 x 6 x 10 Recess 2/S 12-1/4 x 1	1,625	1	Gemini 59A46-I	66253058320

There are many more sizes and specifications available made-to-your-order, including our revolutionary new Norton Quantum ceramic large surface grinding wheels – for a quantum leap in technology. Contact your Norton representative with your custom requirements.

SURFACE GRINDING SEGMENTS



CATEGORY DEFINITION

Surface grinding segments are generally used to grind flat stock or flat surfaces within a workpiece. The segment moves over the workpiece in a flat plane or vice versa. Applications can vary from heavy, rapid stock removal to precision tolerance operations.

- APPLICATIONS:
- Vertical spindle surface grinding
 - Grinding large molds, dies and large plates
 - Producing flat stock
 - Sharpening knives, blades, cutlery
- ABRASIVE GRAIN: Ceramic Alumina, Aluminum Oxide

MATERIAL-TO-PRODUCT RECOMMENDATION GUIDE

MATERIAL	HEAVY-DUTY	GENERAL-DUTY
Aluminum	86A30-E12VBEP	Gemini 30-E
Bronze (hard)		Gemini 30-G
Cast Iron	3NQP30-G12VPS	Gemini 30-G
Hastalloy	86A30-G12VBEP	Gemini 30-E
Inconel	3NQP30-F12VPS	Gemini 30-E
Hardened Steel	3NQP30-G12VPS	Gemini 30-E
High Speed Steel	3NQP30-G12VPS	Gemini 30-E
Soft Steel	86A30-G12VBEP	Gemini 30-G
Stainless Steel 300	86A30-E12VBEP	Gemini 30-E
Stainless Steel 400	86A30-E12VBEP	Gemini 30-F

TROUBLESHOOTING GUIDE

PROBLEM	CORRECTION
Segment acting too hard	Increase rate of downfeed Increase table rotation speed (watch amp-meter) Dress more frequently Consider reducing area of table load
Segment acting too soft	Decrease rate of downfeed Decrease table rotation speed Check for abnormal machine vibration
Glazing and/or burning	Choose a softer grade Increase table speed (watch amp-meter)

TECHtip

- Choose 24 and 30 grit for soft and mild steels.
- Choose 36 and 46 grit for hard steels.
- Choose as coarse a grit size as possible in order to remove stock as quickly as possible (in big chips).
- To maximize production, choose the hardest grade possible that will not overload the machine.



It is the user's responsibility to refer to and comply with ANSI B7.1

SEGMENT BLUEPRINTS

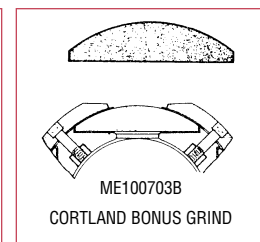
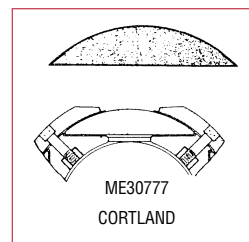
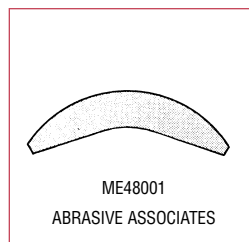
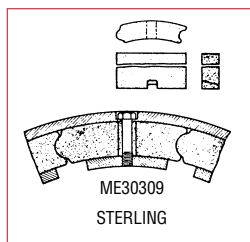
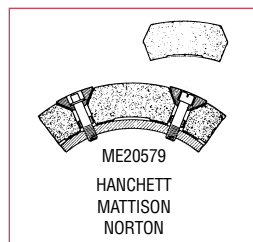

FEATURED PRODUCTS

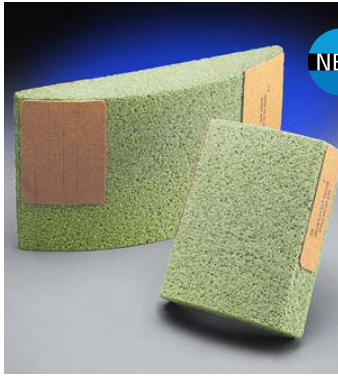

NEW

NORTON QUANTUM CERAMIC ALUMINA SEGMENTS

BEST CHOICE FOR ALL LOW-, MEDIUM-, AND HIGH-FORCE APPLICATIONS RANGING FROM CAST IRON, TO STAINLESS STEEL AND HARD-TO-GRIND ALLOYS

FEATURES

- Revolutionary, engineered ceramic grain shape and chemistry with proven bond technology
- Perform well on old and new machines

BENEFITS

- Versatile; for applications ranging from cast iron, to stainless steel and hard-to-grind alloys
- 33% to 100% longer life versus competitive ceramic products
- 30%+ higher metal removal rate
- 15%+ lower threshold power
- Lowest total grinding costs



NORTON 86A SEGMENTS

BETTER CHOICE FOR VERSATILE, CONSISTENT PERFORMANCE

FEATURES

- Sharper aluminum oxide abrasive

BENEFITS

- Versatile, cooler cutting, consistent performance



GEMINI SEGMENTS

GOOD CHOICE WHEN A BROAD VARIETY OF PARTS ARE GROUND ON ONE MACHINE

FEATURES

- Quality aluminum oxide abrasive blend

BENEFITS

- Excellent value for general purpose use, and for the account where initial price is a main purchasing consideration

AVAILABILITY

					TIER: BEST		BETTER		GOOD	
					NORTON QUANTUM		86A		GEMINI	
					Ceramic Alumina		Aluminum Oxide		Aluminum Oxide Blend	
WIDTH	THICK.	HEIGHT	BLUEPRINT NO.	STD. PKG.	SPEC	UPC NO.	SPEC	UPC NO.	SPEC	UPC NO.
5	1-1/2	6	ME20579 	8	3NQP30-F12VSP 3NQP30-G12VSP	61463677786 66253251526	86A30-F12VBEP	61463650273	Gemini 30-E Gemini 30-F Gemini 30-G	66253050295 66253050297 66253050299
6-13/16	1-1/2	6	ME30309 	8					Gemini 30-E Gemini 30-F	61463677783 61463677784
11	2-1/8	6	ME48001 	5					Gemini 30-F	61463677785
11-1/4	2-1/4	6	ME30777 	5	3NQP36-G12VSP 3NQP24-E12VSP 3NQP24-F12VSP	66253251527 66253255197 66253242829	86A24-E12VBEP 86A24-G12VBEP 86A30-D12VBEP 86A30-E12VBEP 86A30-F12VBEP 86A30-G12VBEP 86A36-E12VBEP 86A46-D12VBEP	61463650279 61463650282 61463603641 61463650285 61463650287 61463650289 61463650291 61463650442	Gemini 30-E Gemini 30-F Gemini 30-G Gemini 30-H	69936699706 69936699709 69936699710 66243447588
11-1/4	2-1/4	8	ME30777 	5	3NQP30-F12VSP 3NQP30-G12VSP	66253238276 66253260330	86A24-G12VBEP	61463650293	Gemini 30-E Gemini 30-F Gemini 30-G Gemini 30-H Gemini 30-I	69936699712 69936699716 69936699717 66243447591 66243447592
11-1/4	3	8	ME100703B 	4	3NQP30-F12VSP 3NQP30-G12VSP	69083156473 66253233120	86A30-D12VBEP 86A30-E12VBEP 86A30-G12VBEP	61463602022 61463650301 61463650304	Gemini 30-E Gemini 30-F Gemini 30-G Gemini 30-H Gemini 30-I	69936699725 69936699727 69936699728 66243447594 66243447595
		1-5/8		10	Vitrified Burr Remover	61463650268*				

*MINIMUM QUANTITY = 2

CYLINDRICAL WHEELS



CATEGORY DEFINITION

Cylindrical wheels are used most often when the part is held between centers and in chucks. There are three methods of cylindrical grinding: plunge, traverse, and angular

- Plunge grinding – wheel is thrust or plunged into the part
- Traverse grinding – wheel moves across the part
- Angular grinding – wheel contacts the part at an angle

TYPICAL INDUSTRIES: Automotive, shipbuilding, engine building, bearing, turbine blades – land- and air-based – and toolroom

SHAPE: Type 01 Straight and Type 07 Recessed 2 Sides

SIZE RANGE: 16", 18", 20", 24" and 30" diameter

ABRASIVE GRAIN: Aluminum Oxide

STATIONARY DRESSING TOOL RECOMMENDATIONS FOR CYLINDRICAL WHEELS

GRINDING WHEEL DIAMETER	DIAMOND CARAT WEIGHT	SINGLE POINT		MULTI-POINT (GRIT)			
		TOOL PRODUCT/PART NO. 0° ANGLE	TOOL PRODUCT/PART NO. 0° ANGLE	SHAPE	TOOL PRODUCT/PART NO. 15° ANGLE	SHAPE	
16" - 20"	3/4	BC7M7 66260195007	BC62 66260195012	1/4 x 1/2 Rect.	BC63 66260195013	1/4 x 1/2 Rect.	
		NS7M7 66260195132	2A6D7 66260195046		2A6E7 66260195049		
21" +	1	BC10M7 66260195009	BC61 66260195011	1/4 x 3/4 Rect.	BC60 66260195010	1/4 x 3/4 Rect.	
		NS10M7 66260195137	1A6A7 66260195031		1A6C7 66260195039		

NS SINGLE POINT DIAMOND TOOLS ARE RESETTABLE. BC DIAMOND TOOLS ARE NOT RESETTABLE. ALL TOOLS SPECIFIED ABOVE HAVE 7/16" DIAMETER SHANKS.

TROUBLESHOOTING GUIDE

PROBLEM	POSSIBLE CAUSES	SUGGESTED CORRECTION
Burn or cracks on workpiece	Wheel too hard Dress is too fine Nozzle not directing coolant properly Work speed too slow or wheel speed too fast Wheel feed too slow causing excess contact time	Try softer wheel or make wheel act softer (see the following Tech Tip) Dress faster Redirect flow Adjust speeds Increase feed rate
Chatter marks on workpiece	Loose spindle, end play, bearing failure Work drive faults, out-of-truth plate Wheel too hard, poor truing, poor mounting	Check wheel spindle on assembly Check gear action, truth, drive on pin pressure Use softer grade; dress wheel correctly; secure mounting
Poor quality finish	Poor quality dressing Diamond insecurely held Misalignment of head and tail stocks Dirty coolant Scored workpiece centers	Reduce final depth of dress on wheel Check and replace diamond and secure properly Check for properly aligned workpiece Clean coolant frequently; use efficient filter Check and lap center holes as required

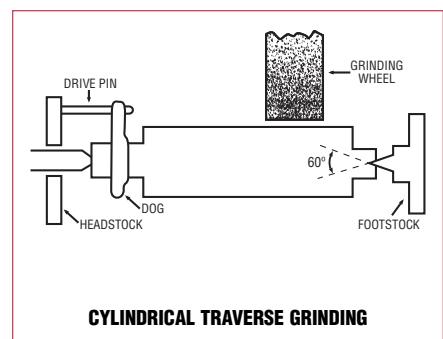
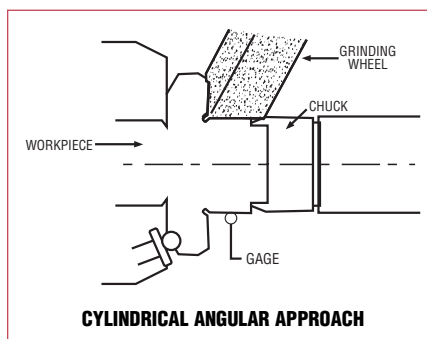
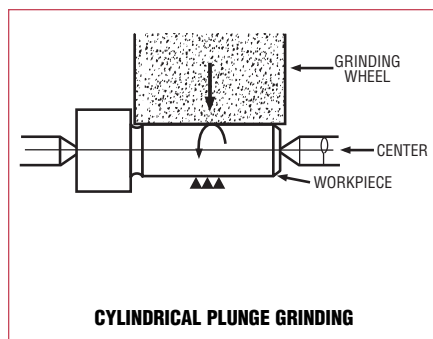

FEATURED PRODUCTS

NORTON 32A

BETTER CHOICE FOR MEDIUM TO HEAVY STOCK REMOVAL

FEATURES

- Sharp monocrystalline aluminum oxide grain – the industry's most versatile abrasive

BENEFITS

- Free cutting on a wide range of applications and materials
- Outstanding form holding

NORTON 86A

BETTER CHOICE FOR LONGER WHEEL LIFE

FEATURES

- Premium abrasive; superior bond system
- Engineered for easy use

BENEFITS

- High grinding G-Ratios (metal removal/wheel wear) increase productivity
- Decrease in dress frequency and/or dress compensation
- Less wheel dressing means lower abrasive costs
- Hold form for better part geometry
- Grind cycles do not need to be altered
- No special operator training is needed

NORTON 64A

GOOD CHOICE FOR VERSATILE PERFORMANCE AT AN ECONOMICAL PRICE

FEATURES

- Specially blended aluminum oxide abrasive coupled with a superior bond
- Broad availability
- Versatile

BENEFITS

- Will maintain high grinding rates without wheel breakdown
- Quick delivery on popular sizes
- Engineered to grind a variety of materials

There are many more sizes and specifications available made-to-your-order, including wheels made from our 55A blank stock for rush orders. Contact your Norton representative with your custom cylindrical requirements. And ask about our revolutionary new Norton Quantum ceramic made-to-order cylindrical wheels – a quantum leap in technology.

TECHtip

TO MAKE A WHEEL ACT SOFTER:

- Increase work speed
- Increase traverse speed
- Increase infeed
- Decrease wheel speed
- Increase dresser traverse rate
- Increase depth of dress per traverse
- Dress more often

TO MAKE A WHEEL ACT HARDER:



- Decrease work speed
- Decrease traverse speed
- Decrease infeed
- Increase wheel speed (do not exceed MAX RPM marked on wheel)
- Dress at slower traverse rate
- Decrease depth of dress per traverse



It is the user's responsibility to refer to and comply with ANSI B7.1

CYLINDRICAL WHEELS

AVAILABILITY

SIZE (D X T X L)	STD. PKG.	TIER: BETTER		GOOD	
		ABRASIVE: Aluminum Oxide		Aluminum Oxide	
		SPEC.	PART NO.	SPEC.	PART NO.
TYPE 01 STRAIGHT					
16 x 1 x 5	1	32A60-J8VBE 32A60-K5VBE	66253464836 66253464837	64A60-K8V127	66253466722
16 x 1 x 8	1	32A60-K5VBE	66253464826		
16 x 1-1/2 x 5	1	32A46-H8VBE	66253464925		
16 x 2 x 5	1	32A46-J8VBE 32A60-K5VBE	66253464995 66253464960	64A60-K8V127	66253466721
18 x 2 x 5	1			64A60-K8V127	66253466719
20 x 1 x 8	1	86A60-J8V127 86A80-J8V127	69078608982 69078608983	Gemini 46-H	66253246937
20 x 1-1/2 x 5	1	32A46-H8VBE	69078665382		
20 x 2 x 5	1			64A60-J8V127	69078666713
20 x 2 x 8	1	32A46-I8VBE 32A60-K5VBE	69078665433 69078665490	64A60-K8V127	69078666712
20 x 2 x 10	1			Gemini 36-J Gemini 60-J	66253246956 66253246959
20 x 2 x 12	1	32A46-I8VBE	69078665455		
20 x 3 x 8	1			64A46-I8V127 64A60-J8V127	69078666447 69078608140
24 x 2 x 12	1			64A60-K8V127 64A80-K8V127	69083166710 69083166711
30 x 2 x 12	1			64A60-J8V127	69210466704
30 x 3 x 12	1			64A60-J8V127 64A60-K8V127	69210466697 69210466698
30 x 4 x 12	1			64A60-J8V127	69210401774
TYPE 07 RECESSED TWO SIDES					
18 x 2 x 8	1	32A46-I8VBE	66253465110		
Rec 2/S 10-1/2 x 1/2					
20 x 2 x 8	1	32A46-I8VBE	69078665537		
Rec 2/S 11-1/2 x 1/2					
20 x 3 x 8	1	32A46-I8VBE	69078665686		
Rec 2/S 11-1/4 x 1/2					
20 x 3 x 10	1	32A46-I8VBE	69078665575		
Rec 2/S 12-1/4 x 5/8					
20 x 6 x 10	1	32A46-I8VBE	69078665854		
Rec Side A 12-1/4 x 2					
Rec Side B 12-1/4 x 1					

There are many more sizes and specifications available made-to-your-order, including wheels made from our 55A blank stock for rush orders. Contact your Norton representative with your custom cylindrical requirements. And ask about our revolutionary new Norton Quantum ceramic made-to-order cylindrical wheels – a quantum leap in technology.

CENTERLESS AND FEED WHEELS



CATEGORY DEFINITION

Centerless grinding is a production process that produces extremely close tolerances on metal cylindrical forms or parts. Centerless grinding is used on a wide variety of workpieces. The key components in the process are the grinding wheel, the work rest blade (used to support the work) and the regulating or "feed" wheel (the drive mechanism for the workpiece).

- APPLICATIONS:
- High production operations on large volume continuous grinding
 - Parts ranging from miniature roller bearings to train axles and bearings
 - Fastener and tool manufacturing
 - Steel mills
 - Automotive related components
 - Bearing
 - Machine tools
 - Aircraft
 - Turbine blades – land- and air-based

SHAPE: Centerless wheels: Type 01 Straight
Feed wheels: Type 01 Straight and Type 07 Recessed 2 Sides

SIZE RANGE: Centerless wheels: 16" – 24" diameter
Feed wheels: 12" and 14" diameter

ABRASIVE GRAIN: Aluminum Oxide, Aluminum Oxide/Silicon Carbide Blend

MATERIAL-TO-PRODUCT RECOMMENDATION GUIDE

APPLICATION	WHEEL SPECIFICATIONS
Alnico	64A60-KVCE, 57A60-K8VCN, 32AC54-QB
Cast Iron	64A60-KVCE, 57A60-K8VCN, 32AC54-QB
Hastalloy	64A60-LVCE
Inconel	64A60-LVCE
Stainless	64A60-KVCE
Stainless – 300 series	64A60-KVCE
Stainless – 400 series (commercial finish)	57A60-K8VCN, 64A60-KVCE
Steel – Hard or Soft	
Less than 1/2" diameter	57A80-L8VCN, 64A80-LVCE
5/8" to 2-1/2" diameter	57A60-L8VCN, 64A60-LVCE
Over 2-1/2" diameter	57A60-K8VCN, 64A60-LVCE, 32AC54-QB
High Speed (commercial finish)	64A60-KVCE, 57A60-K8VCN, 32AC54-QB
High Speed (fine finish)	32AC90-QB

NOTE: GRADE, GRIT AND ABRASIVE TUNING MAY BE NECESSARY TO OBTAIN OPTIMUM PERFORMANCE

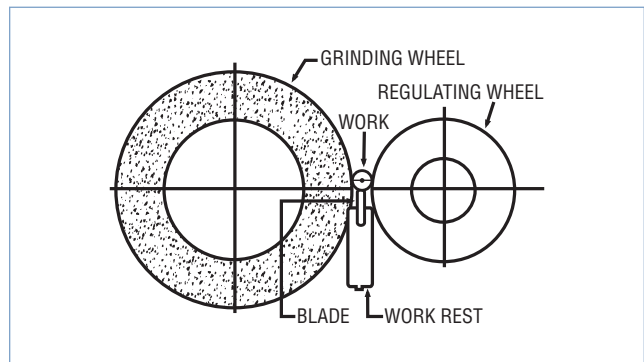

STATIONARY DRESSING TOOL RECOMMENDATIONS FOR CENTERLESS WHEELS

GRINDING WHEEL DIAMETER	DIAMOND CARAT WEIGHT	SINGLE POINT	INDEXABLE SINGLE POINT	MULTI-POINT (GRIT)		TOOL PRODUCT/PART NO. 15° ANGLE	SHAPE
		TOOL PRODUCT/PART NO. 0° ANGLE	TOOL PRODUCT/PART NO. 0° ANGLE	TOOL PRODUCT/PART NO. 0° ANGLE	SHAPE		
11" - 14"	1/2	BC5M7 66260195005	BCUD5 66260195025	BC65 66260195015	3/8 Round	BC63 66260195013	1/4 x 1/2
		NS5M7 66260195127	NSUD5 66260195163				
15" - 20"	3/4	BC7M7 66260195007	N/A	BC62 66260195012	1/4 x 1/2	BC63 66260195013	1/4 x 1/2
		NS7M7 66260195132	NSUD7 66260195164				
21" +	1	BC10M7 66260195009	N/A	BC61 66260195011	1/4 x 3/4	BC60 66260195010	1/4 x 3/4
		NS10M7 66260195137	NSUD10 66260195165				

STATIONARY DRESSING TOOL RECOMMENDATIONS FOR FEED WHEELS

FEED WHEEL DIAMETER	TOOL CARAT WEIGHT	TOOL SHANK DIAMETER	INDEXABLE SINGLE POINT	
			TOOL PRODUCT NO.	TOOL PART NO.
Up to 14"	1/2	7/16"	NSUD5	66260195163

See the 55A-VH Blank Stock page for additional (FastTrack) Centerless specifications.

TECHtip

PROPER WHEEL MOUNTING

1. Thoroughly clean spindle and flange bearing area of all dirt and foreign material.
2. Inspect for worn, distorted or damaged areas on flanges and spindle.
3. If mounting a wide centerless wheel on a spindle (i.e., twin-grip), do not use grease or other petroleum lubricants. Use a silicone spray lubricant on the spindle to ease mounting the wheel, if necessary.
4. Ensure mount up arrow is at the top of the wheel. In the case of butted sets, assemble so that the arrow is formed across the top of the wheel face.
5. Ensure proper blotters are installed; one on each flange mating surface. Always use new blotters.
6. Install blotter flange and snug up the bolts only finger tight.
7. Using a torque wrench, tighten all bolts in an alternating pattern from side to side to 15 foot pounds.
8. Repeat the same tightening sequence, increasing the torque to 35 foot pounds.
 - a.) for wide wheels (18"-20"), torque the bolts at 45 to 50 foot pounds
 - b.) for narrower wheels (2"-12"), a torque of 35 foot pounds is sufficient
9. Retorque the flange bolts to specification after the first eight hours of operation.

- Use vitrified bond wheels for form holding and plunge grinding
- Use resinoid bond wheels for stock removal, long irregular parts and faster throughfeed grinding
- Vitrified Centerless Wheel Speeds:
 - 64A46-KVCE wheels: 6500 SFPM max. operating speed
 - All other vitrified centerless stock products: 8500 SFPM max. operating speed
 - Always check wheel speed markings on wheels before running wheels



It is the user's responsibility to refer to and comply with ANSI B7.1

TO MAKE A WHEEL ACT SOFTER:

- Increase work speed/regulating wheel speed
- Increase throughput speed/regulating wheel speed
- Increase infeed
- Decrease wheel speed
- Dress at a faster traverse rate

TO MAKE A WHEEL ACT HARDER:

- Decrease work speed/regulating wheel speed
- Decrease throughput speed/regulating wheel speed
- Decrease infeed
- Increase wheel speed (observe safe limits)

FEATURED PRODUCTS

32AC WHEELS

BETTER CHOICE WHEN ONE WHEEL IS USED TO GRIND SEVERAL DIFFERENT MATERIALS

FEATURES

BENEFITS

- Aluminum oxide/silicon carbide abrasive blend in a strong resin bond
- Ideal when one wheel is used to grind several different materials from high to low tensile strength

57A WHEELS

GOOD CHOICE FOR GENERAL PURPOSE APPLICATIONS

FEATURES

BENEFITS

- Versatile/durable abrasive
- Superior vitrified bond system
- High G-ratios (metal removed/wheel wear)
- Longer wheel life; excellent form holding

64A WHEELS

GOOD CHOICE FOR GRINDING A VARIETY OF MATERIALS, ECONOMICALLY

FEATURES

BENEFITS

- Specially blended aluminum oxide abrasive coupled with a superior vitrified bond
- Broad availability
- Versatile
- Will maintain high grinding rates without wheel breakdown
- Quick delivery on popular sizes
- Engineered to grind a variety of materials



Centerless Wheels

AVAILABILITY

SIZE (D X T X H)	STD. PKG.	BETTER		GOOD	
		CENTERLESS RESINOID WHEELS		CENTERLESS VITRIFIED WHEELS	
		Aluminum Oxide/Silicon Carbide		Aluminum Oxide	
		SPEC.	PART NO.	SPEC.	PART NO.
TYPE 01 STRAIGHT					
16 x 4 x 10	1			57A80-L8VCN	66253465001
20 x 2 x 12	1			53A60-K8VCN	69078665347
20 x 4 x 12	1			64A60-KVCE	69078666723
				64A60-MVCE	69078666725
				64A80-LVCE	69078666727
20 x 6 x 12	1	32AC54-QB	69078666545	37C60-LV	69078666296
		32AC54-SB	61463677788	57A60-K8VCN	69078665800
				57A80-M8VCN	69078665785
				64A60-KVCE	69078666729
				64A80-MVCE	69078666734
				Gemini 60-L	66253246994
20 x 8 x 12	1	32AC54-QB	69078666546	57A60-K6VCN	69078665817
				57A60-L6VCN	69078665818
				57A80-M6VCN	69078665821
				64A60-KVCE	69078666748
				64A60-LVCE	69078666749
				64A80-KVCE	69078666751
				64A80-LVCE	69078666752
				Gemini 54-J	66253247001
24 x 3 x 12	1			64A60-K8V127	69083166708
24 x 6 x 12	1	32AC54-QB	69083166547	Gemini 60-K	66253247047
24 x 8 x 12	1	32AC54-QB	69083166548	57A60-K6VCN	69083166737
				64A60-LVCE	69083166767
				64A80-KVCE	69083166769
24 x 10 x 12	1	32AC54-QB	69083166549	57A60-K6VCN	69083166771
		32AC90-QB	61463677790	64A60-KVCE	69083166791
				64A80-KVCE	69083166788
24 x 20 x 12 Composed of 2 Wheels 10" Thick (ME90362)	1	32AC54-QB	69083166552		
		32AC54-SB	69083166553		

Rubber Bond Feed Wheels

AVAILABILITY

SIZE (D X T X H)	STD. PKG.	BETTER	
		Aluminum Oxide	
		SPEC.	PART NO.
TYPE 01 STRAIGHT			
12 x 2 x 5	1	57A80-RR51	66253222840
TYPE 07 RECESSED TWO SIDES			
12 x 4 x 5	1	57A80-RR51	66253222844
Rec 2 Sides 7-1/2 x 1/2			
12 x 6 x 5	1	57A80-RR51	66253222846
Rec Side A 7-1/2 x 1-1/2			
Rec Side B 7-1/2 x 1/2			
12 x 6 x 5	1	57A80-RR51	66253222847
Rec 2 Sides 7-1/2 x 1-1/2			
12 x 8 x 5	1	57A80-RR51	66253222850
Rec Side A 7-1/2 x 2-1/2			
Rec Side B 7-1/2 x 1-1/2			
14 x 8 x 5	1	57A80-RR51	66253322859
Rec Side A 8 x 2			
Rec Side B 8 x 1-1/2			
14 x 20 x 6	1	57A80-RR51	66253322196
Rec 2 Sides 8-1/2 x 1-1/2			
Butted Feed Wheels			
Composed of 2 Wheels			
10" Thick (ME91512)			

Plastic Bond Feed Wheels

AVAILABILITY

SIZE (D X T X H)	STD. PKG.	BETTER	
		Aluminum Oxide	
		SPEC.	PART NO.
TYPE 07 RECESSED TWO SIDES			
12 x 8 x 5	1	57A80-RP4	66253222199
Rec Side A 7-1/2 x 2-1/2			
Rec Side B 7-1/2 x 1-1/2			
14 x 20 x 6	1	57A80-RP4	66253322200
Rec 2 Sides 8-1/2 x 1-1/2			
Butted Feed Wheels			
Composed of 2 Wheels			
10" Thick (ME91512)			

There are many more sizes and specifications available made-to-your-order, including wheels made from our 55A blank stock for rush orders. Contact your Norton representative with your custom centerless requirements.

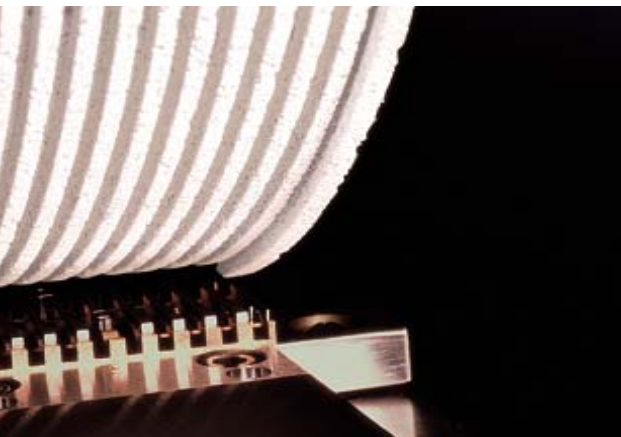

CATEGORY DEFINITION

Norton creepfeed wheels are the best creepfeed wheels in the industry. These high-performance blank stock wheels can be altered to your dimensional requirements.

APPLICATIONS:	Heat-sensitive, porous grinding of difficult-to-grind alloys
TYPICAL INDUSTRIES:	Aerospace, automotive, toolroom, gear, energy
SIZE RANGE:	Blank Stock: 16" – 25" diameter Finished Wheel: 14" – 25" diameter
GRADE/POROSITY:	C29 – F26
ABRASIVE GRAIN:	Ceramic Alumina, Fused Aluminum Oxide

KEY PROGRAM FEATURES

- Standard lead-time: 2 weeks
- Alteration Parameters:
 - Diameter may be altered to 2" smaller than the original blank stock diameter
 - Thickness may be altered to 1/2 the original blank stock thickness
 - Bore may be altered to parameters shown in chart

UNFINISHED SIZE D X T X H	FINISHED SIZE		
	OUTSIDE DIAMETER (NO SMALLER THAN)	WIDTH (NO THINNER THAN)	BORE (MAX.)
16 x 4 x 5	14	2	8
20 x 2-1/2 x 8	18	1-1/4	12
20 x 4 x 8	18	2	12
24 x 4 x 8	22	2	12
25 x 2-1/2 x 8	23	1-1/4	12
25 x 3-1/2 x 8	23	1-3/4	12

FEATURED PRODUCTS



NORTON QUANTUM

BEST CHOICE FOR VERSATILITY, MAXIMUM PERFORMANCE, AND COST SAVINGS

FEATURES

- Revolutionary, sharp, durable, engineered ceramic alumina grain shape and chemistry; highly-porous

BENEFITS

- Versatile; for all low-, medium- and high-force applications ranging from cast iron, to stainless steel and hard-to-grind Inconel and titanium
- Perform well on old and new machines
- 30%+ higher metal removal rate
- 15%+ lower threshold power
- Highest productivity; lowest total grinding cost



VORTEX

BETTER CHOICE FOR HEAT-SENSITIVE, POROUS GRINDING OF DIFFICULT-TO-GRIND ALLOYS

FEATURES

- High-performance, engineered, fused aluminum oxide abrasive, optimally spaced
- Highly porous and permeable

BENEFITS

- High metal removal rates; able to grind large areas of contact
- Exceptional part integrity and quality; superior surface finish
- Long wheel life: dramatically shorter grinding cycles = less wheel changes and more parts/wheel = high productivity

AVAILABILITY

TIER:

BEST

BETTER

TRADENAME:

Quantum Unfinished Blank Stock

Vortex A/O Unfinished Blank Stock

SIZE (D X T X H)

SPEC.

UF BLANK PART NO.

SPEC.

UF BLANK PART NO.

TYPE 01 STRAIGHT



16 x 4 x 5

IPA60-D29VTX 00310312485
IPA60-E26VTX 00310312486

20 x 2-1/2 x 8

IPA60-F17VTX 00310303131
IPA60-E26VTX 00310303130
IPA80-D29VTX 00310303132

20 x 4 x 8

IPA60-D29VTX 00310303133
IPA60-E26VTX 00310303134

24 x 4 x 8

IPA60-C29VTX 03103925091
IPA60-F26VTX 00310303135

25 x 2-1/2 x 8

3NQ60-E24VCF3 00310404676

IPA60-E26VTX 00310404613

25 x 3-1/2 x 8

3NQ60-E24VCF3 00310404614

IPA60-E26VTX 00310404678

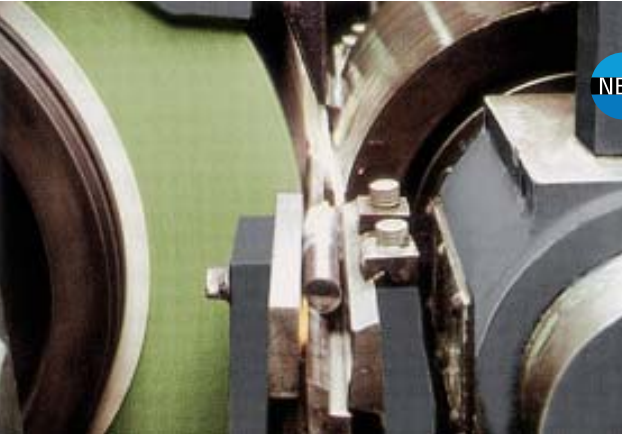

CATEGORY DEFINITION

The newest-generation ceramic Norton Quantum wheels are the best vitrified wheels in the marketplace. They will grind with superior results in most applications. They can be altered to your specific needs within two weeks of receipt of your order.

APPLICATIONS:	<ul style="list-style-type: none"> • Centerless plunge and throughfeed grinding • Surface grinding • Cylindrical grinding
SIZE RANGE:	Blank Stock: 18" – 30" diameter Finished Wheel: 16" – 30" diameter
GRIT RANGE:	60, 80, and 120
GRADE RANGE:	J – M
ABRASIVE GRAIN:	Ceramic Alumina

FEATURED PRODUCTS



NORTON QUANTUM

BEST CHOICE FOR VERSATILITY, MAXIMUM PERFORMANCE, AND COST SAVINGS

FEATURES

- Revolutionary, sharp, durable, engineered ceramic alumina grain shape and chemistry; highly-porous

BENEFITS

- Versatile; for all low-, medium- and high-force applications ranging from cast iron, to stainless steel and hard-to-grind Inconel and titanium
- Perform well on old and new machines
- 30%+ higher metal removal rate
- 15%+ lower threshold power
- Highest productivity; lowest total grinding cost

AVAILABILITY

TIER:

BEST

TRADENAME:

Quantum Ceramic Unfinished Blank Stock

SIZE (D X T X H)	SPECIFICATION	UNFINISHED BLANK PART NO.
18 x 1 x 5	3NQ80-K10VS	00310405993
18 x 2 x 5	3NQ80-K10VS	00310405994
18 x 3 x 5	3NQ80-K10VS	00310405995
20 x 1 x 8	3NQ80-K10VS	00310405985
20 x 1 x 12	3NQ80-K10VS	00310406017
20 x 1 x 12	3NQ120-MVS	00310405924
20 x 2 x 8	3NQ80-K10VS	00310406036
20 x 3 x 8	3NQ80-K10VS	00310406037
20 x 6 x 12	3NQ80-L10VS	00310406018
20 x 8 x 12	3NQ80-L10VS	00310406026
24 x 1 x 8	3NQ80-K10VS	00310406034
24 x 1 x 12	3NQ80-K10VS	00310406038
24 x 2 x 8	3NQ80-K10VS	00310406035
24 x 2 x 12	3NQ80-K10VS	00310406029
24 x 3 x 8	3NQ80-K10VS	00310406046
24 x 3 x 12	3NQ80-K10VS	00310406030
24 x 6 x 12	3NQ80-L10VS	00310406031
24 x 8 x 12	3NQ80-L10VS	00310406032
24 x 10 x 12	3NQ80-L10VS	00310406033
30 x 2 x 12	3NQ60-J10VS	00310406047
30 x 2 x 12	3NQ80-K10VS	00310406048

There are many finished sizes and specifications available. Contact your local Norton distributor or salesperson with your size and specification requirements for quantity guidelines, quotations and helpful ordering instructions.

Please note "2-week delivery request" if needed, on your order.

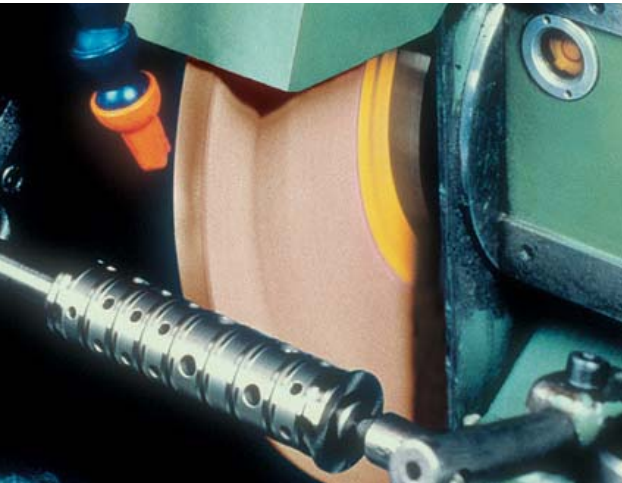

CATEGORY DEFINITION

55A-VH blank stock wheels are competitively-priced, monocrystalline grain wheels specifically engineered for numerous carbon steel applications requiring moderate to heavy stock removal rates. They can be altered to your specific needs within two weeks of receipt of your order.

APPLICATIONS:	<ul style="list-style-type: none"> Centerless plunge and throughfeed grinding Surface grinding Cylindrical grinding
SIZE RANGE:	Blank Stock: 18" – 42" diameter Finished Wheel: 16" – 42" diameter
GRIT RANGE:	60 – 120
GRADE RANGE:	I – M
ABRASIVE GRAIN:	Aluminum Oxide

FEATURED PRODUCTS



55A-VH BETTER CHOICE FOR PRECISION GRINDING OF CARBON STEEL AND CAST IRON

FEATURES

- Advanced combination of monocrystalline 55A aluminum oxide abrasive and superior VH bond

BENEFITS

- Superior performance on centerless plunge and throughfeed, surface, and cylindrical grinders
- Up to 2X the life of competitive aluminum oxide wheels
- Ideal for simple- to complex-shaped components
- Increased productivity; more quality parts at lowest cost per part

AVAILABILITY

TIER:

BETTER

OTHER:

A/O Unfinished Blank Stock

SIZE (D X T X H)	GRIT	GRADE	UNFINISHED BLANK PART NO.
18 x 1 x 5	80	K	00310404552
18 x 2 x 5	80	K	00310404554
18 x 3 x 5	80	K	00310404555
20 x 1 x 8	60	K	00310020910
	100	I	00310020913*
20 x 1 x 12	100	K	00310302177
	120	K	00310302220
	120	M	00310064512
20 x 1-1/2 x 12	80	K	00310302221
	100	K	00310302222
20 x 2 x 8	80	K	00310020918
	100	K	00310020920
	120	M	00310064252
20 x 6 x 12	60	K	00310020963
	60	L	00310020964*
24 x 1 x 8	80	K	00310021884
24 x 1 x 12	60	K	00310020921
	80	M	00310020923
24 x 1-1/4 x 12	60	M	00310302224
24 x 1-1/2 x 8	80	K	00310302223
24 x 1-1/2 x 12	80	K	00310302225
	80	M	00310302226
24 x 2 x 8	80	K	00310021885
24 x 2 x 12	60	K	00310020924
	80	I	00310020926
24 x 3 x 8	80	K	00310021757
24 x 5 x 12	60	L	00310302227
24 x 6 x 12	60	K	00310020968
24 x 8 x 12	60	L	00310020971*
	100	K	00310302228
24 x 10 x 12	80	K	00310020972
30 x 2 x 12	60	L	00310020929
30 x 3 x 12	60	L	00310020930
42 x 1-1/2 x 12	60	M	00310020931

* AVAILABLE WHILE SUPPLIES LAST.

There are many finished sizes and specifications available. Contact your local Norton distributor or salesperson with your size and specification requirements for quantity guidelines, quotations and helpful ordering instructions.

Please note "2-week delivery request" if needed, on your order.



CATEGORY DEFINITION

VH, VPMS, and VPLS Worm Profile Wheels

Norton 38A, X25A, and ceramic alumina blend – Norton SG, Targa (TG), Norton Quantum, and BRG – open-structured, high-performance, non-stock gear wheels are designed to produce high metal removal rates with less power draw.

One Norton Quantum and numerous BRGL sharp ceramic alumina wheels are available through this FastTrack Service.

VSPF and VPAP Angle Profile Wheels

Quality non-stock wheels are available in X25A, and ceramic alumina blends – Norton SG and Targa (TG). X25A-VPAP and Targa 3TGP-VSPF blank stock lines are offered for the FastTrack Service.

All Norton profile wheels are altered on state-of-the-art CNC controlled machines and are finished using Saint-Gobain dressing wheels. The Saint-Gobain dressing wheels and machines give these wheels excellent accuracy and repeatability.

SIZE RANGE:	Blank Stock: 220mm – 400mm diameter Finished Wheel: 190mm – 400mm diameter
GRIT RANGE:	54 – 120
ABRASIVE GRAIN:	Ceramic Alumina and Aluminum Oxide

KEY PROGRAM FEATURES

- Standard lead time: 2 weeks
- Alteration Parameters:
 - Diameter may be altered to 2" smaller than the original blank stock diameter
 - Thickness may be altered to 1/2 the original blank stock thickness

AVAILABILITY

SIZE (D X T X H)	SPECIFICATION	TIER:	
		BEST	BETTER
TRADENAME:		Quantum/3TGP Ceramic	BRGL – Ceramic X25A – A/O
		Unfinished Blank Stock	Unfinished Blank Stock
		UNFINISHED BLANK PART NO.	UNFINISHED BLANK PART NO.
WORM PROFILE WHEELS – NQ-VH – 75M/S MAXIMUM OPERATING SPEED			
300mm x 125mm x 160mm	3NQ90-J10VH	00310394338	
WORM PROFILE WHEELS – VPMS – 60M/S MAXIMUM OPERATING SPEED			
220mm x 180mm x 76.2mm	BRGL80-GVPHS		00310048274
	BRGL100-HVPHS		00310048279*
	BRGL120-GVPHS		00310048280*
	BRGL120-HVPHS		00310048281*
WORM PROFILE WHEELS – VPLS – 43M/S MAXIMUM OPERATING SPEED			
350mm x 104mm x 160mm	BRGL80-FVPLS		00310066975*
	BRGL80-GVPLS		00310066976*
	BRGL80-HVPLS		00310066977*
	BRGL100-FVPLS		00310066979*
	BRGL100-GVPLS		00310066991
	BRGL120-FVPLS		00310066993*
	BRGL120-GVPLS		00310066994*
	BRGL120-HVPLS		00310066995*
ANGLE PROFILE WHEELS – VSPF/VPAP – 50M/S MAXIMUM OPERATING SPEED			
400mm x 50mm x 127mm	3TGP60-G20VSPF	00310404596	
	X25A54-F19VPAP		00310066998*
	X25A54-H19VPAP		00310067000*
	X25A70-F19VPAP		00310067011*
	X25A70-G19VPAP		00310067012*
400mm x 75mm x 127mm	3TGP60-G20VSPF	00310404597	
400mm x 100mm x 127mm	3TGP60-G20VSPF	00310404598	

* AVAILABLE WHILE SUPPLIES LAST.

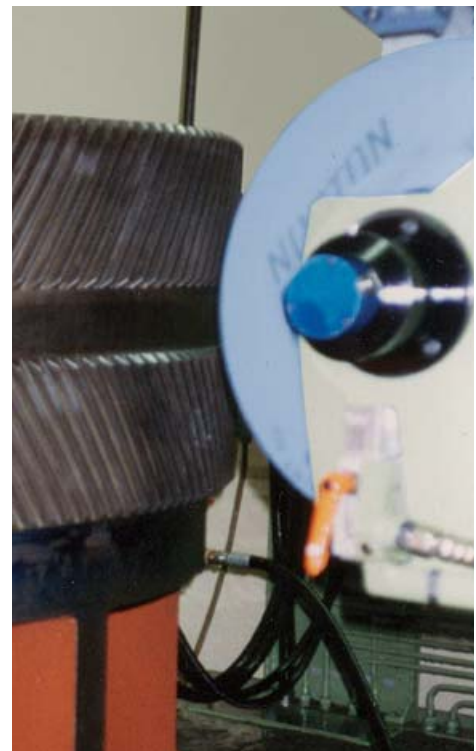





CATEGORY DEFINITION

Our Norton offering is the industry's most comprehensive line of stock and made-to-order products to true (restore the wheel's profile) and dress (opening – to remove stock – or closing – to finish) the face of the wheel. In addition to these catalog stock stationary tools, Norton manufactures a full line of custom stationary tools, rotary diamond dressers and truing/dressing devices to meet all your specific application needs.

Contact us at 1-800-438-4773.

APPLICATIONS: Truing and dressing conventional and superabrasive wheels, straight, step, radius and form dressing

TOOL TYPES: Single Point, Multi-Point, Blade, Form, Toolroom and Cluster Tools, and Truing Devices

DETERMINING THE BEST VALUE

- Remember that diamonds are a rare commodity—the larger the stone and the better the quality, the higher the initial cost. The key to successful diamond tool productivity and use is based on the “cost per dress.” Normally, higher quality diamonds and a proactive resetting program will result in the lowest “cost per dress.”
- In those situations where a resetting program is not feasible or low initial cost is the primary purchasing consideration, Norton offers a complete line of non-resettable tools.

RESETTING YOUR USED DIAMOND TOOLS

Resetting – Minimizing Your Cost

Buying a higher quality diamond is your best value, especially if you participate in a proactive resetting program. Although initial cost may be higher, the payback comes through several factors:

- Diamond durability, providing longer tool life
- Tighter form tolerances
- Consistent finish rates
- Resetting the diamond lowers the overall tooling cost

Used properly, the overall cost of a higher quality, resettable diamond will compare favorably with that of an inexpensive, non-resettable diamond. Initially, the best diamond point is selected for use. When returned, the next best diamond point is selected for resetting, and so on.

To ensure you get the best value for your diamond:

- Rotate the diamond tool $\frac{1}{4}$ turn periodically to maintain a sharp point
- Use proper flow of coolant to protect the diamond from heat which can create fracturing of the diamond
- Excessive wear on the diamond point may impact the ability to reset the diamond. The widest point of the diamond is referred to as the girth. The diamond girth is buried in a powder metal matrix. Using a diamond into the girth zone might impact the ability to reset other diamond points

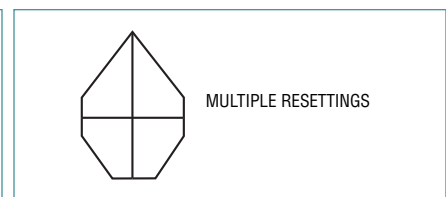
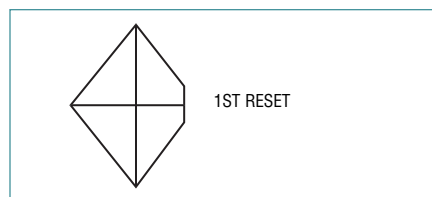
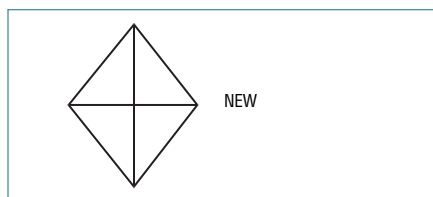

TECHtip

SELECTING THE CORRECT DIAMOND TOOL

To determine the type of Norton dressing tool to use, it is best to think about the desired shape of the wheel face. Finished wheel face shapes are generally categorized into six types, as illustrated below.

TYPICAL WHEEL FORMS DRESSED BY STATIONARY DIAMOND TOOLS

Look for the applicable wheel forms beside each product type to help you choose the correct product for your application.

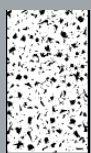

STRAIGHT



TAPERED



CONVEX

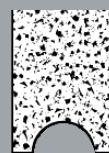

CONCAVE

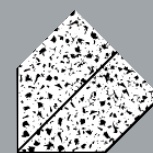

ANGLED



MULTI-ANGLED

Single Point Tools

Our Norton line of single point tools is used in straight and simple form dressing applications. It includes: resettable and non-resettable products, tools for all abrasive types (conventional and advanced ceramic grains) and the technology-leading Norton "Indexable" tool design.

WHEEL FORMS DRESSED BY THESE TOOLS

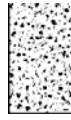

STRAIGHT



TAPERED



CONVEX



SPECcheck

SELECTION GUIDE

Stock Tools for Ceramic Abrasive Wheels

SG/Ceramic Engineered for use on ceramic (SG, NQ, Targa, etc.) wheels but may also provide significant benefits when used on conventional abrasive products. These tools are furnished with top quality specially selected diamonds.

BCSG/Ceramic Economical alternative to an "SG" tool. Best choice when a disposable tool is preferred.

Stock Tools for Conventional Abrasive Wheels

NS Engineered for use on conventional abrasives. These high quality, value-priced tools can be used for a variety of dressing applications.

BC Economical alternative to an "NS" tool. Best choice when a disposable tool is preferred.

SELECTING THE CORRECT SINGLE POINT TOOL:

- Identify the wheel abrasive type: aluminum oxide, silicon carbide, or ceramic
- Determine the wheel diameter
 - to select the optimum carat weight
- Determine the tool holder size
 - to select appropriate shank diameter

EXAMPLES OF SINGLE POINT TOOL SELECTION

Conventional Wheel Spec:	32A46-IVBE 7" x 1/2" x 1-1/4" Customer's machine has a 7/16" tool holder
Tool Selections:	Resettable: NS2M7 or NSUD2 (Indexable) Non-Resettable: BC2M7 or BCUD2 (Indexable)
Ceramic Wheel Spec:	5SG60-JVS or 5NQ60-IVS 10" x 1" x 3" Customer's machine has a 3/8" tool holder
Tool Selections:	Resettable: SG3M6 Non-Resettable: BCSG3M6

TECHtip

- Rigidly mount single point tools at a 10° - 15° angle to the wheel centerline with a line drawn through the center of the wheel, pointing in the direction of wheel travel.
- Point of contact should be slightly below centerline of wheel as shown.
- Use coolant whenever possible.
- Normal infeed is .001" per pass.
- Lead selections range from .002" - .010" per wheel revolution.
- Rotate the tool 1/4 turn periodically to maintain a sharp point.

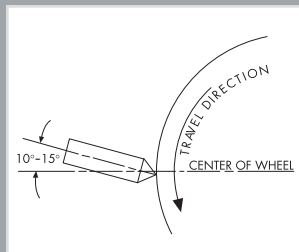

To optimize applications using ceramic abrasives and/or tools, normal dressing parameters must change. Reduce infeed by 25%. Significant reductions in the amount of infeed and frequency of dress will result in substantially lower cost per part ground.

SINGLE POINT DRESS TRAVERSE RATE

Select a Lead Value based on desired Surface Finish and run the formula below.

FINISH	LEAD VALUE (PER WHEEL REVOLUTIONS)
For Coarse Finish (approx. 64 RMS)	.008" to .010"
For Medium Finish (approx. 32 RMS)	.005" to .009"
For Fine Finish (approx. 16 RMS)	.002" to .004"

LEAD VALUE X WHEEL SPEED (RPM) = TRAVERSE RATE IN INCHES/MINUTE

- Slower traverse rates result in a closed wheel face and lower surface finish readings on the workpiece.
- Faster traverse rates result in an open wheel face that produces greater stock removal and a rougher workpiece finish.



It is the user's responsibility to refer to and comply with ANSI B7.1

Single Point Tools CONTINUED



Single Point Tools for Truing/Dressing Ceramic Abrasives

SG/CERAMIC SINGLE POINT TOOLS

FEATURES

- Specially selected broad-shaped, diamond
- Each diamond is hand selected for stone shape, quality and structural integrity
- Multi-purpose

BENEFITS

- Withstands the increased grinding pressures of ceramic abrasives
- Consistent tool performance
- Accommodate most straight dressing and simple form dressing applications
- Stand up to ceramic (Norton SG, NQ, TG, etc.) abrasive sharpness; can also be used to dress conventional abrasives

RESETTABLE SG/CERAMIC SINGLE POINT TOOLS

FEATURES AND BENEFITS

- Norton high quality diamond and a proactive resetting program will result in the lowest dressing cost per part

NON-RESETTABLE BCSG/CERAMIC SINGLE POINT TOOLS

FEATURES AND BENEFITS

- The best selection when a resetting program is not feasible or low initial cost is the primary purchasing consideration

WHEEL DIAMETER	TOOL CARAT WEIGHT	TOOL DIAMETER	TOOL LENGTH	BEST		GOOD	
				PRODUCT NO.	3 SETTABLE PTS (2 RESETS) PART NO.	PRODUCT NO.	NON-RESETTABLE PART NO.
STOCK SINGLE POINT TOOLS FOR TRUING/DRESSING CERAMIC ABRASIVES							
UP TO 7"	1/4 (.25)	3/8" 7/16"	2" 2"	SG2M6 SG2M7	66260195365 66260195366	BCSG2M6 BCSG2M7	66260157007 66260156905
8" TO 10"	1/3 (.33)	3/8" 7/16"	2" 2"	SG3M6 SG3M7	66260195367 66260195368	BCSG3M6 BCSG3M7	66260157008 66260156906
11" TO 14"	1/2 (.50)	3/8" 7/16"	2" 2"	SG5M6 SG5M7	66260195369 66260195370	BCSG5M6 BCSG5M7	66260157009 66260156907
15" TO 20"	3/4 (.75)	3/8" 7/16"	2" 2"	SG7M6 SG7M7	66260195371 66260195372	BCSG7M7	66260156908
21"+	1 (1.00)	7/16"	2"			BCSG10M7	66260157010

STANDARD PACKAGE = 1 TOOL

WHEEL FORMS DRESSED BY THESE TOOLS

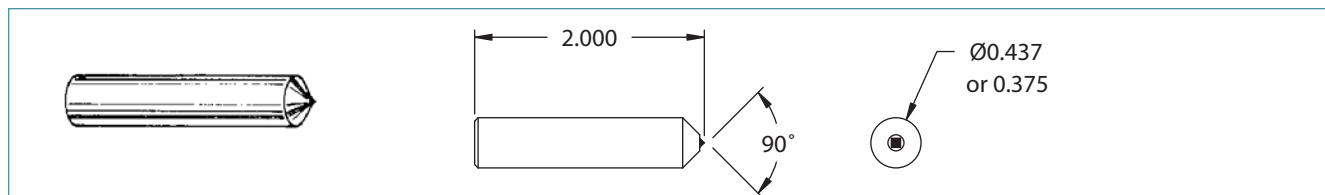
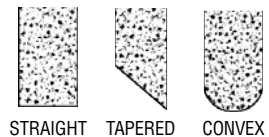

TECHtip

STOCK SINGLE POINT TOOL MARKING SYSTEM

DIAMOND QUALITY	DIAMOND SIZE	SHANK DESIGN	SHANK DIAMETER
SG/Ceramic	1 = 1/5 (.20) carat	M	6 = 3/8"
BCSG/Ceramic	2 = 1/4 (.25) carat	J	7 = 7/16"
NS	3 = 1/3 (.33) carat		
BC	5 = 1/2 (.50) carat		
	7 = 3/4 (.75) carat		
	10 = 1 carat		

EXAMPLE: NS 2 M 6

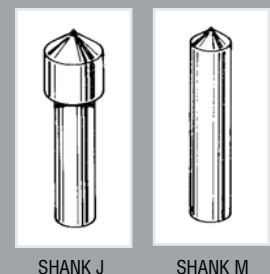

SHANK J

SHANK M

Single Point Tools CONTINUED



Single Point Tools for Truing/Dressing Conventional Abrasives

CONVENTIONAL SINGLE POINT TOOLS

FEATURES

- Consistent diamond structure and shape
- Well defined, sharp diamond point
- Steeper 60 degree included angle head design

BENEFITS

- Repeatable dressing performance
- Durable; maximum cost effectiveness for dressing conventional abrasives
- Greater machine and part clearance produce forms with tighter tolerances

RESETTABLE NS (NORTON STANDARD) SINGLE POINT TOOLS

FEATURES AND BENEFITS

- High quality diamonds, value priced
- Selection of the correct tool and a proactive resetting program will result in the lowest dressing cost per part

NON-RESETTABLE BC SINGLE POINT TOOLS

FEATURES AND BENEFITS

- The best selection when a resetting program is not feasible or low initial cost is the primary purchasing consideration

WHEEL DIAMETER	TOOL CARAT WEIGHT	TOOL DIAMETER	BETTER		GOOD	
			PRODUCT NO.	2 SETTABLE PTS (1 RESET) PART NO.	PRODUCT NO.	NON-RESETTABLE PART NO.
STOCK SINGLE POINT TOOLS FOR TRUING/DRESSING CONVENTIONAL ABRASIVES						
INTERNAL WHEEL	1/5 (.20)	3/8" 7/16"			BC1M6 BC1M7	66260195021 66260195022
UP TO 7"	1/4 (.25)	3/8" 7/16"	NS2M6 NS2M7	66260195116 66260195117	BC2M6 BC2M7	66260195000 66260195001
8" TO 10"	1/3 (.33)	3/8" 7/16"	NS3M6 NS3M7	66260195121 66260195122	BC3M6 BC3M7	66260195002 66260195003
11" TO 14"	1/2 (.50)	3/8" 7/16"	NS5M6 NS5M7	66260195126 66260195127	BC5M6 BC5M7	66260195004 66260195005
15" TO 20"	3/4 (.75)	7/16" 7/16"	NS7M7 NS7J7	66260195132 66260195130	BC7M6 BC7M7	66260195006 66260195007
21" +	1 (1.00)	3/8" 7/16" 7/16"	NS10M6 NS10M7 NS10J7 *	66260195136 66260195137 66260195135	BC10M6 BC10M7	66260195008 66260195009

* J-SHANK TOOLS ARE AVAILABLE IN 7/16" DIAMETER WITH 5/8" HEAD

STANDARD PACKAGE = ONE TOOL

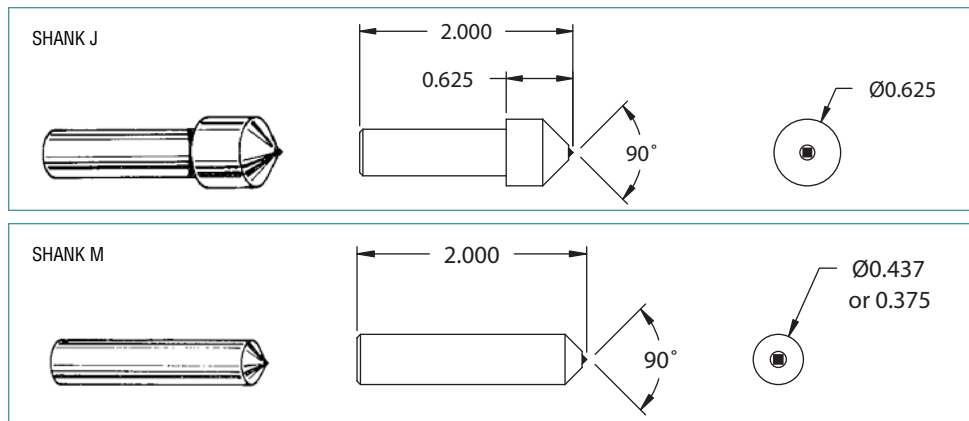
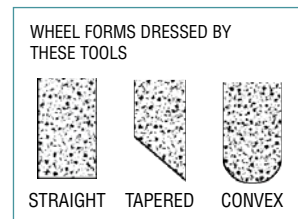

Refer to our Diamond and cBN Superabrasive Standard Product Catalog #8068 sections on www.nortonindustrial.com or your Norton representative for more in-depth information on all Norton superabrasive stock and made-to-order products.

Single Point Tools CONTINUED

Indexable Single Point Tools

Indexable tools are specifically designed to alleviate any misalignment issues and are the tools of choice for CNC grinders. They feature a two-part construction with the head and shank as separate pieces. After the initial installation, operators simply turn the indexable head with a wrench, while the tool shank remains secure (and aligned) in the tool holder.



INDEXABLE SINGLE POINT TOOLS

FEATURES

- Easily turned without removing tool from the holder
- U-Dex-It and Mini-Dex tools have a 60° included angle head design

BENEFITS

- Easier for operators to turn than conventional tools – increasing frequency of beneficial tool turning
- Extended life; less downtime and increased productivity
- Provides additional form versatility through better machine and part clearance
- Excellent choice for regulating wheels

Indexable Single Point Tools for Truing/Dressing Ceramic Abrasives

NON-RESETTABLE BCSGUD/CERAMIC U-DEX-IT INDEXABLE SINGLE POINT TOOLS

FEATURES AND BENEFITS

- These U-Dex-It tools contain specially selected diamonds to withstand increased ceramic (SG, Quantum NQ, Targa TG, etc.) grinding pressures
- Ideal for centerless grinders; the head can be turned, using standard 5/8" wrench, through the hole in the side of the wheel guard without removing the guard
- The best selection when a resetting program is not feasible or low initial cost is the primary purchasing consideration

GOOD				
WHEEL DIAMETER	TOOL CARAT WEIGHT	TOOL SIZE	PRODUCT NO.	NON-RESETTABLE PART NO.
STOCK INDEXABLE SINGLE POINT TOOLS FOR TRUING/DRESSING CERAMIC ABRASIVES				
UP TO 7"	1/4 (.25)	7/16" X 1-7/16" WITH 5/8" HEAD	BCSGUD2	66260162669
11" TO 14"	1/2 (.50)	7/16" X 1-7/16" WITH 5/8" HEAD	BCSGUD5	66260159894

STANDARD PACKAGE = ONE TOOL

WHEEL FORMS DRESSED BY THESE TOOLS

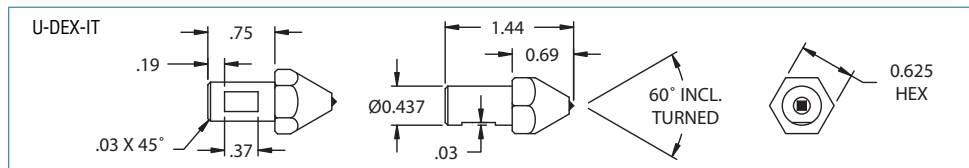
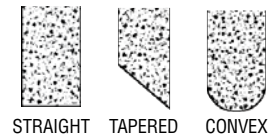

Indexable Single Point Tools for Truing/Dressing Conventional Abrasives

RESETTABLE NORTON STANDARD NSUD U-DEX-IT INDEXABLE SINGLE POINT TOOLS

FEATURES AND BENEFITS

- High quality diamonds, value priced
- Ideal for centerless grinders; the head can be turned, using standard 5/8" wrench, through the hole in the side of the wheel guard without removing the guard
- Selection of the correct tool and a proactive resetting program will usually result in the lowest dressing cost per part

RESETTABLE NORTON STANDARD NSMD MINI-DEX INDEXABLE SINGLE POINT TOOLS

FEATURES AND BENEFITS

- High quality diamonds, value priced
- Use a standard 7/16" wrench to turn; designed for internal, bearing race, and twist drill flute machines
- Selection of the correct tool and a proactive resetting program will usually result in the lowest dressing cost per part

NON-RESETTABLE BCUU U-DEX-IT INDEXABLE SINGLE POINT TOOLS

FEATURES AND BENEFITS

- Ideal for centerless grinders; the head can be turned, using standard 5/8" wrench, through the hole in the side of the wheel guard without removing the guard
- The best selection when a resetting program is not feasible or low initial cost is the primary purchasing consideration

Single Point Tools CONTINUED

Indexable Single Point Tools for Truing/Dressing Conventional Abrasives CONTINUED

WHEEL DIAMETER	TOOL CARAT WEIGHT	TOOL SIZE	BETTER		GOOD	
			PRODUCT NO.	2 SETTABLE PTS (1 RESET) PART NO.	PRODUCT NO.	NON-RESETTABLE PART NO.
STOCK INDEXABLE SINGLE POINT TOOLS FOR TRUING/DRESSING CONVENTIONAL ABRASIVES						
UP TO 7"	1/4 (.25)	7/16" X 1-7/16" WITH 5/8" HEAD 1/4" X 1-3/16" WITH 7/16" HEAD	NSMD2	66260195171	BCUD2	66260195023
8" TO 10"	1/3 (.33)	7/16" X 1-7/16" WITH 5/8" HEAD 1/4" X 1-3/16" WITH 7/16" HEAD	NSUD3 NSMD3	66260195162 66260195172	BCUD3	66260195024
11" TO 14"	1/2 (.50)	7/16" X 1-7/16" WITH 5/8" HEAD	NSUD5	66260195163	BCUD5	66260195025
15" TO 20"	3/4 (.75)	7/16" X 1-7/16" WITH 5/8" HEAD	NSUD7	66260195164		
21" +	1 (1.00)	7/16" X 1-7/16" WITH 5/8" HEAD	NSUD10	66260195165		

STANDARD PACKAGE = ONE TOOL

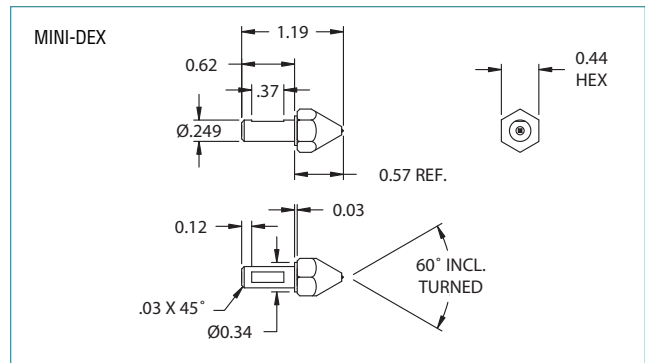
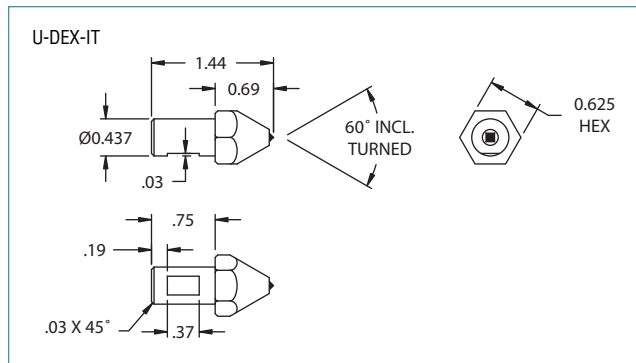

Internal Grinding Tools



RESETTABLE INTERNAL GRINDING TOOLS

FEATURES AND BENEFITS

- Q style shank is used on a Heald internal grinder (resettable).

BEST					
MACHINE TYPE	CARAT WEIGHT	SHANK DIAMETER	TOOL LENGTH	PRODUCT NO.	2 SETTABLE PTS (1 RESET) PART NO.
STOCK INTERNAL GRINDING TOOLS					
HEALD	1/5 (.20)	7/16"	1"	NI21Q7	66260195180

STANDARD PACKAGE = 1 TOOL

WHEEL FORMS DRESSED BY THESE TOOLS



STRAIGHT



TAPERED



CONVEX



CONCAVE

SHANK Q FOR HEALD MACHINE

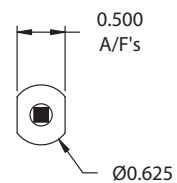
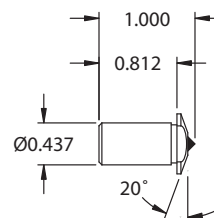

Single Point Tools CONTINUED

Thread Grinding Tools



RESETTABLE SG/CERAMIC THREAD GRINDING TOOLS

FEATURES AND BENEFITS

- These wheels are used on J & L and Excello thread grinding machines to accurately dress the grinding wheels that form the desired thread configuration (non-resettable).

					BEST	
MACHINE TYPE	SHANK DIAMETER	TOOL LENGTH	INCLUDED ANGLE	MAX. RADIUS ON POINT	PRODUCT NO.	NON-RESETTABLE PART NO.
STOCK THREAD GRINDING TOOLS						
J & L	1/4"	1"			38RL4*	66260195100
J & L	1/4"	1"	80°	.010"	NT1L4	66260195187
EXCELLO	3/8"	1-5/8"	60°	.010"	NT106	66260195190

* 38RL4 IS A MULTI-POINT (GRIT) 30 - 40 MESH TOOL
STANDARD PACKAGE = 1 TOOL

WHEEL FORMS DRESSED BY THESE TOOLS



STRAIGHT



TAPERED

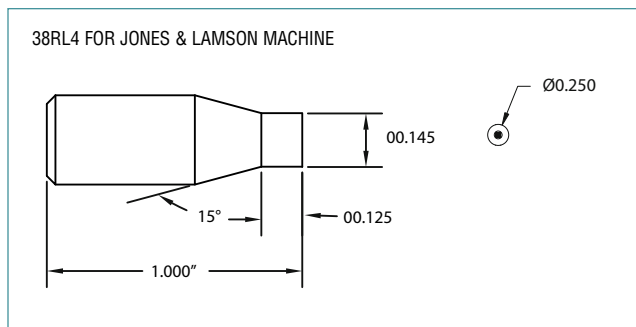
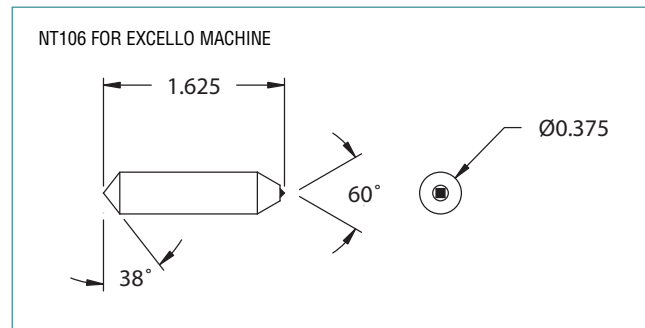
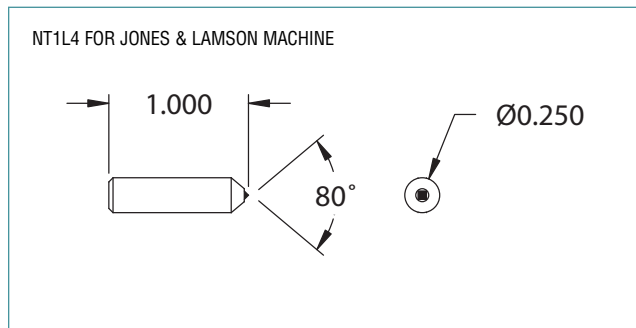

Refer to our Diamond and cBN Superabrasive Standard Product Catalog #8068 sections on www.nortonindustrial.com or your Norton representative for more in-depth information on all Norton superabrasive stock and made-to-order products.

Multi-Point (Grit) Tools

Since Norton conventional and high-performance Multi-Point tools never need turning or resetting, they are the most economical way to accomplish a variety of straight, tapered, and step dressing operations on all sizes of cylindrical, centerless, surface, and toolroom grinding wheel applications.



WHEEL FORMS DRESSED BY THESE TOOLS

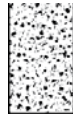

STRAIGHT



TAPERED

NORTON MULTI-POINT TOOLS

FEATURES

- Uniformly distributed diamonds in a tough, durable matrix
- Fresh, multiple diamond points exposed in truing operation; no turning or resetting required
- Overall diamond weight exceeds equivalent single point tool

BENEFITS

- Consistent performance throughout tool life
- Faster, more consistent straight face dressing with maximum efficiency and longer tool life than single point tools
- The most economical way to dress straight and tapered forms

TECHtip

MULTI-POINT TOOLS – STRAIGHT FACE DRESSING AND TRUING

- Most multi-point tools are used for straight face dressing.
- Tool should have full face contact with the wheel.
- With new tool, 3–5 passes at .005" per pass should be taken to expose diamonds.
- Infeed per pass .001" - .002"
- Use coolant whenever possible.
- Use appropriate lead (and traverse rate).
- Contact your Norton representative for proper tool selection for Targa wheels.

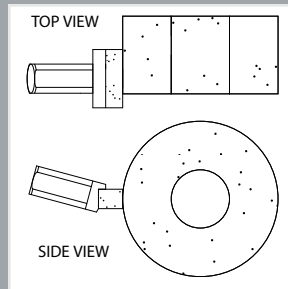

MULTI-POINT DRESS TRAVERSE RATE

Select a Lead Value based on desired Surface Finish and run the formula below.

FINISH	LEAD VALUE (PER WHEEL REVOLUTIONS)
For Coarse Finish (approx. 64 RMS)	.023" to .030" (.58mm – .76mm)
For Medium Finish (approx. 32 RMS)	.013" to .022" (.33mm – .57mm)
For Fine Finish (approx. 16 RMS)	.006" to .012" (.15mm – .33mm)

LEAD VALUE X WHEEL SPEED (RPM) = TRAVERSE RATE IN INCHES/MINUTE

- Slower traverse rates result in a closed wheel face that produces less stock removal and improved workpiece finish.
- Faster traverse rates result in an open wheel face that produces greater stock removal and a rougher workpiece finish.



It is the user's responsibility to refer to and comply with ANSI B7.1

SPECcheck

SELECTING THE CORRECT MULTI-POINT TOOL

- Identify the wheel abrasive type: ceramic (Norton SG, Quantum NQ, Targa TG), aluminum oxide, or silicon carbide
- Determine the wheel diameter and grit size
- Determine the tool's approach angle to the centerline of the wheel
- Identify the tool holder diameter
- Use 1E shape for angular wheel slide, cylindrical grinding and for shoulder or step truing

EXAMPLES OF MULTI-POINT TOOL SELECTION

- Conventional Wheel Spec:** 32A46-IVBE 7" x 1/2" x 1-1/4"
Customer's machine has a 3/8" tool holder
- Tool Selection:** 1R6J6
- Ceramic Wheel Spec:** 5SG60-JVS or 5NQ60-IVS 10" x 1" x 3"
Customer's machine has a 7/16" tool holder
- Tool Selections:** SG1R6J7

Multi-Point (Grit) Tools (CONTINUED)

SPECcheck

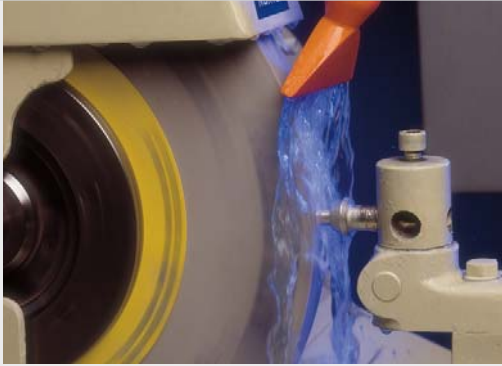

MULTI-POINT TOOL DIAMOND SECTION SPECIFICATIONS

SHAPE	WIDTH	LENGTH	DEPTH	TOOL APPROACH ANGLE TO WHEEL	FOR WHEEL DIAMETER
1A	1/4"	3/4"	5/16"	0°	Over 20"
2A	1/4"	1/2"	3/8"	0°	15" – 20"
3A	5/32"	3/8"	1/4"	0°	Over 20"
1E	5/32"	3/8"	5/16"	–	
2E	1/4"	1/2"	1/2"	–	20" x 2" and up
1R	1/4" Round		1/4"	0°	Up to 10"
2R	3/8" Round		3/8"	0°	11" – 14"

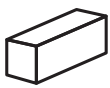

A SHAPE IS USED PRIMARILY FOR STRAIGHT FACE DRESSING.

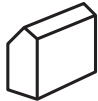

E SHAPE (DOUBLE ANGLE TOP FACE) IS USED FOR STANDARD N-FACE WHEELS, ANGULAR WHEELS, FACE AND SIDE TRUING OF CYLINDRICAL WHEELS, AND IN STEP DRESSING.



R SHAPE IS USED FOR STRAIGHT FACE DRESSING WHERE THE TOOL HOLDER IS PERPENDICULAR TO THE WHEEL FACE (NO DRAG ANGLE), AND ON THREAD GRINDING MACHINES.

MULTI-POINT TOOL MARKING SYSTEM

DIAMOND SHAPE	TOOL DIAMOND SIZE	TO DRESS GRINDING WHEELS WITH GRIT SIZE OF:	SHANK DESIGN	SHANK DIAMETER
1A	4 =	46 grit	See the following pages for shank configurations	6 = 3/8"
2A	6 =	54 - 100 grit		7 = 7/16"
3A	8 =	120 - 150 grit		8 = 1/2"
1E	12 =	150+ grit		
2E	14 =	Special Applications		
1R				
2R				

EXAMPLE: 1A 6 A 7

Multi-Point Tools for Straight Dressing

SG MULTI-POINT TOOL SHAPE AND SHANK AVAILABILITY

SHAPE SG1A SHANK A



SHAPE SG1A SHANK C



SHAPE SG2A SHANK D



SHAPE SG2A SHANK E



SHAPE SG1R SHANK J



SHAPE SG2R SHANK K



CONVENTIONAL TOOLROOM MULTI-POINT TOOLS

SHAPE 1A



BC-60

SHAPE 1A



BC-61

SHAPE 2A



BC-62

SHAPE 2A



BC-63

SHAPE 1R



BC-64

SHAPE 1R



BC-65

CONVENTIONAL ABRASIVE MULTI-POINT TOOL SHAPE AND SHANK AVAILABILITY

SHAPE 1A SHANK A



SHAPE 1A SHANK B



SHAPE 1A SHANK C



SHAPE 2A SHANK D



SHAPE 2A SHANK E



SHAPE 3A SHANK F



SHAPE 3A SHANK G



SHAPE 1E SHANK F



SHAPE 1R SHANK J



SHAPE 2R SHANK K



SHAPE 3R SHANK L



SHAPES 3A (F AND G SHANKS) ARE USED FOR FORM, SHAPE, AND STEP TRUING. SHAPE 1E IS USED FOR ANGLE DRESSING

TECHtip

- To optimize applications using ceramic abrasives/tools, normal dressing parameters must change. Significant reductions in the amount of infeed and frequency of dress will result in significantly lower cost per part ground.
- While all Norton SG/Ceramic tools have been designed to improve the efficiency of ceramic grinding applications, they can also offer significant benefits in many applications using conventional abrasives.
- When first using a Norton SG/Ceramic tool, make 3 to 5 passes at .005" infeed to ensure full face contact between the dressing tool and wheel face.
- Reduce normal dressing infeed by half. Do not exceed infeed of .002" per pass.
- The lead selection should be between .006"-.030" per wheel revolution. Faster traverse with a Norton SG/Ceramic tool generally provides an open wheel face that can maximize productivity of the ceramic abrasive.

Multi-Point (Grit) Tools (CONTINUED)

Multi-Point Tools for Truing and Straight Dressing

SG/CERAMIC MULTI-POINT TOOLS

FEATURES AND BENEFITS

- Designed specifically for use on ceramic (Norton SG, Quantum NQ, Targa TG. etc.) abrasives, SG tools contain a higher diamond concentration to withstand the increased grinding pressures generated by the ceramic abrasives. These tools have improved life and dress quality; they can also offer significant benefits in many applications using conventional abrasives.

STANDARD MULTI-POINT TOOLS

FEATURES AND BENEFITS

- The ideal selection for use on conventional abrasives in high-production applications

BC MULTI-POINT TOOLS

FEATURES AND BENEFITS

- These general-purpose tools are the ideal selection for conventional toolroom applications
- BC multi-point tools contain a specially selected diamond size for a broad range of dressing applications.

WHEEL DIAMETER	WHEEL GRIT SIZE	TOOL APPROACH ANGLE	TOOL DIAMETER	BEST		BETTER		GOOD	
				SG ABRASIVES PRODUCT NO.	PART NO.	CONVENTIONAL ABRASIVES PRODUCT NO.	PART NO.	CONVENTIONAL TOOLROOM PRODUCT NO.	PART NO.
MULTI-POINT TOOLS FOR STRAIGHT DRESSING									
UP TO 10"	54 TO 100	0°	7/16	SG1R6J7	66260195377	1R6J7	66260195088	BC64	66260195014
		0°	3/8						
11" TO 14"	54 TO 100	0°	7/16	SG2R6K7	66260195378	2R6K7	66260195096	BC65	66260195015
15" TO 20"	46	0°	7/16			2A4D7	66260195045		
		15°	7/16			2A4E7	66260195048		
		15°	7/16			1B4C7	66260195060		
	54 TO 100	0°	7/16	SG2A6D7	66260195375	2A6D7	66260195046	BC62	66260195012
		15°	7/16			2A6E7	66260195049		
	120 TO 150	0°	7/16			2A8D7	66260195047		
		15°	7/16			2A8E7	66260195050		
21" +	46	0°	7/16			1A4A7	66260195030		
		15°	7/16			1A4C7	66260195038		
	54 TO 100	0°	7/16	SG1A6A7	66260195373	1A6A7	66260195031	BC61	66260195011
15°		7/16	1A6B7			66260195035			
15°		7/16	SG1A6C7	66260195374	1A6C7	66260195039	BC60	66260195010	
	120 TO 150	15°	7/16			1A8C7	66260195040		



STRAIGHT

STANDARD PACKAGE = ONE TOOL

Multi-Point Tools for Form, Shape, or Step Dressing Conventional Abrasives

WHEEL DIAMETER	WHEEL GRIT SIZE	TOOL APPROACH ANGLE	TOOL DIAMETER	BETTER	
				PRODUCT NO.	PART NO.
STOCK MULTI-POINT TOOLS FOR FORM, SHAPE, AND STEP DRESSING					
ALL	54 TO 100	0°	7/16"	3A6F7	66260195055
		15°	7/16"	3A6G7	66260195975
	120 TO 150	15°	7/16"	3A8G7	66260195058

STANDARD PACKAGE = ONE TOOL

WHEEL FORMS DRESSED BY THESE TOOLS



STRAIGHT



TAPERED

WHEEL DIAMETER	WHEEL GRIT SIZE	TOOL APPROACH ANGLE	TOOL DIAMETER	BETTER	
				PRODUCT NO.	PART NO.
STOCK MULTI-POINT TOOLS FOR ANGULAR DRESSING CONVENTIONAL ABRASIVES					
ALL	54 TO 100	0°	7/16"	1E6F7	66260195080

STANDARD PACKAGE = ONE TOOL

WHEEL FORMS DRESSED BY THESE TOOLS



TAPERED

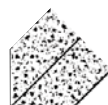

ANGLED

High Performance Grit Tools

Norton High Performance grit tools are used in the same manner as multi-point tools, but are designed to produce a superior finish. They are used on 120 - 150 grit wheels. The traverse rates are equal to or faster than ordinary tools. Mounted on standard shanks, standard High Performance grit tools have a 3/8" wide by .100" thick diamond impregnated blade with a greater number of sharp points than in ordinary multi-point tools.

Since High Performance grit tools contain a higher concentration of diamond than found in standard multi-point tools, they are well suited for ceramic abrasive applications.

Typical Machines and Applications

- HP4439: cylindrical machines, grinding thrust walls, bearing diameters and multi-diameter shafts with radii
- HP4511: angular machines plunge grinding multi-diameter shafts and plunge grinding on dual-wheel forms
- HP4595: cylindrical machines grinding main bearing and lobes on camshafts
- HP4596: centerless machines step grinding and machines dual-wheel grinding transmission shafts

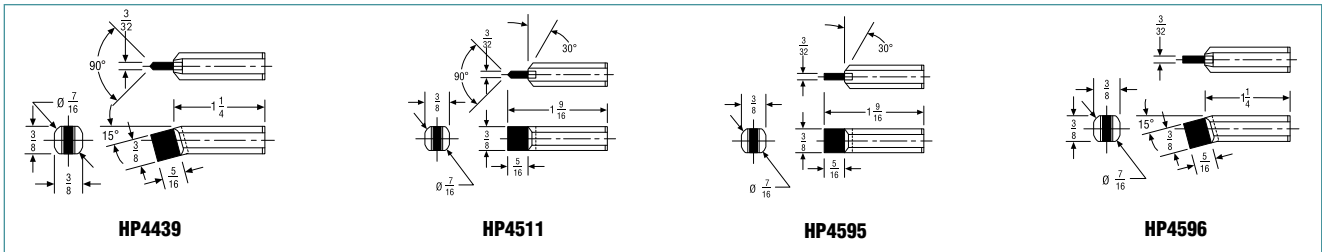

WHEEL DIAMETER	WHEEL GRIT SIZE	SHANK DIAMETER	TOOL LENGTH	BEST	
				PRODUCT NO.	PART NO.
STOCK HIGH PERFORMANCE GRIT TOOLS					
UP TO 20"	120 TO 150	7/16"	1-9/16"	HP4439	66260195270
UP TO 20"	120 TO 150	7/16"	1-9/16"	HP4511	66260195271
UP TO 20"	120 TO 150	7/16"	1-9/16"	HP4595	66260195272
UP TO 20"	120 TO 150	7/16"	1-9/16"	HP4596	66260195273

STANDARD PACKAGE = ONE TOOL

WHEEL FORMS DRESSED BY THESE TOOLS



STRAIGHT



TAPERED



Blade Tools

With the choice of natural and synthetic diamond in three performance/price tiers, Norton blade tools can meet all your angle, step, and radius dressing requirements for cylindrical, surface, and centerless grinding.

WHEEL FORMS DRESSED BY THESE TOOLS



STRAIGHT



TAPERED

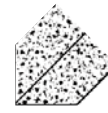

ANGLED



MULTI-ANGLED

Blade Tools CONTINUED

USB (UNIFORM SYNTHETIC BLADE) BLADE TOOLS (ALL ARE MADE-TO-ORDER)

FEATURES

- Synthetic diamond with a controlled diamond shape provides a constant cross section of diamond to the wheel throughout the life of the tool

BENEFITS

- Provides consistent wheel conditioning from the first dress to last
- Ideal for close tolerance wheel dressing on manual and CNC grinders, long production runs, and critical form and finish applications (e.g. automotive cam, crank, and valve grinding)
- Economical, long-lasting alternative to chisel-type tools for centerless form grinding

MULTI-CUT BLADE TOOLS (AVAILABLE IN STOCK AND MADE-TO-ORDER)

FEATURES

- Manufactured with top quality elongated-shaped

BENEFITS

- The choice when natural diamond is preferred on surface, natural diamond cylindrical, and centerless grinders
- Durable performing tools in a medium price range

LONG LIFE BLADE TOOLS (ALL ARE MADE-TO-ORDER)

FEATURES

- Manufactured with processed elongated-shaped natural diamond

BENEFITS

- Developed as the first generation of the blade tool line for surface, cylindrical, and centerless grinders
- The choice when initial price is the primary purchasing consideration

BETTER MULTI-CUT TOOLS

WHEEL DIAMETER (WIDTH < 9")	TOOL APPROACH ANGLE	SHANK DIAMETER	APPROXIMATE DIAMETER OF DIAMOND	MINIMUM RADIUS AND CONCAVE TO BE DRESSED	PRODUCT NO.	PART NO.
12" TO 17"	15°	7/16"	.055"	.028	MC355	66260195266
18" TO 29"	15°	7/16"	.075"	.038	MC375	66260195267

THESE STOCK TOOLS ARE COMPOSED OF 1 LAYER WITH 3 DIAMONDS. THESE TOOLS ARE NOT RESETTABLE OR RELAPPABLE.
STANDARD PACKAGE = ONE TOOL

WHEEL FORMS DRESSED BY THESE TOOLS

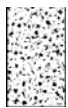

STRAIGHT



TAPERED



ANGLED



MULTI-ANGLED

Refer to our Diamond and cBN Superabrasive Standard Product Catalog #8068 sections on www.nortonindustrial.com or your Norton representative for more in-depth information on all Norton superabrasive stock and made-to-order products.



Form Tools

Norton Form Tools have diamond lapped to specific angles and radii required for a particular application, machine, contour dressing system, or CNC operation. Due to the high degree of accuracy necessary, the diamond is of special shape and quality.

WHEEL FORMS DRESSED BY THESE TOOLS



CONVEX



CONCAVE

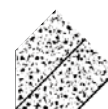

ANGLED



MULTI-ANGLED

Form Tools CONTINUED

CONE POINT TOOLS

FEATURES AND BENEFITS

- The Norton vacuum braze technology used in the manufacturing of cone points surpasses all traditional diamond retention methods.
- Benefits of this technology include absolute diamond retention, diamond pullout prevention during the dressing cycle, and longer tool life through multiple relaps.
- Because the diamond is accurately coned to the specific included angle and radius, these tools are ideal when the most intricate, precise forms and radii are required.
- Can be relapped.

U-Dex-It Cone Point Tool

Used for precision dressing of intricate forms and radii. Specially designed with 5/8" indexable head for easy turning during use. These tools can be relapped.

BEST

INCLUDED ANGLE ON DIAMOND	RADIUS ON DIAMOND	TOOL CARAT WEIGHT	SHANK DIAM.	TOOL LENGTH	PRODUCT NO.	RELAPPABLE PART NO.
75°	.020"	.50	7/16"	1.678"	CPUD720-7	66260158981

STANDARD PACKAGE = ONE TOOL

WHEEL FORMS DRESSED BY THESE TOOLS



CONVEX



CONCAVE

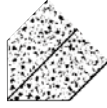

ANGLED



MULTI-ANGLED

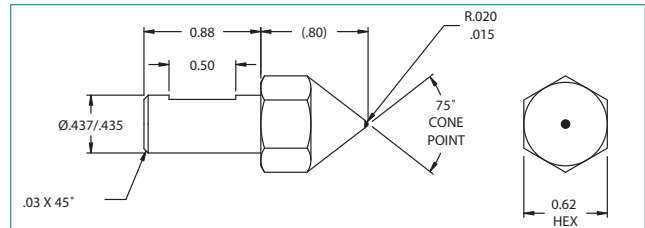

SPECcheck

CONE POINT TOOL MARKING SYSTEM

TOOL TYPE	INCLUDED ANGLE ON DIAMOND	RADIUS ON DIAMOND	CARAT WEIGHT	SHANK DIAMETER
CP	6 = 60°	05 = .005"	L = .10 - .15	6 = 3/8"
	7 = 75°	10 = .010"	M = .20 - .25	7 = 7/16"
	9 = 90°	15 = .015"	H = .33	
		20 = .020"	X = .50	
		25 = .025"		
		30 = .030"		

EXAMPLE: CP 6 10 M-6

Standard Cone Point Tool

These tools are used for precision dressing when the most intricate forms and radii are required. Can be relapped.

BEST

INCLUDED ANGLE ON DIAMOND	RADIUS ON DIAMOND	TOOL CARAT WEIGHT	SHANK DIAM.	TOOL LENGTH	PRODUCT NO.	RELAPPABLE PART NO.
60°	.010"	.20 - .25	3/8"	2"	CP610M-6	66260195240

STANDARD PACKAGE = ONE TOOL

WHEEL FORMS DRESSED BY THESE TOOLS



CONVEX



CONCAVE

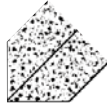

ANGLED



MULTI-ANGLED

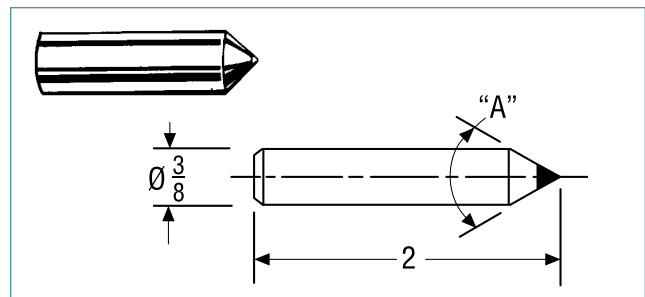

Refer to our Diamond and cBN Superabrasive Standard Product Catalog #8068 sections on www.nortonindustrial.com or your Norton representative for more in-depth information on all Norton superabrasive stock and made-to-order products.

TECHtip

HOW TO USE FORM DRESSING TOOLS

- Form Tools should be used in compliance with the guidelines established for the machine or dress.
- Proper centerline and light infeeds are essential to minimize side pressure. Excessive pressure will cause the diamond to fracture.
- Cone point tools should be rotated approximately 1/4 turn daily.

Form Tools CONTINUED

Chisel Point Tool for Toyoda Grinders

High-precision chisel point tool designed for forming intricate shapes and radii. Specifically engineered to fit Toyoda machine series GL32 and GL4, it can also be used on various straight and angle-head grinders – for dressing conventional and ceramic abrasive wheels, sizes 12" to 24". This tool can be reset/relapped.

BEST						
INCLUDED ANGLE ON DIAMOND	RADIUS ON DIAMOND	TOOL CARAT WEIGHT	SHANK DIAM.	TOOL LENGTH	PRODUCT NO.	RELAPPABLE PART NO.
STOCK CHISEL POINT TOOL						
55°	.020"	.75	7/16"	1.10"	CHT520-7	66260103741

STANDARD PACKAGE = ONE TOOL

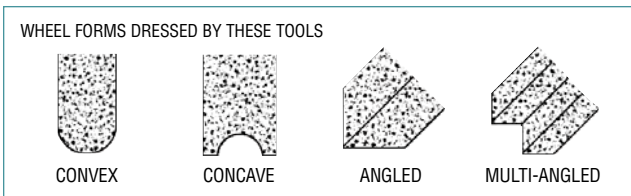
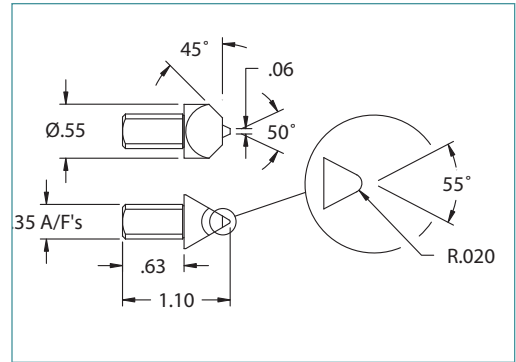

See the “Diamond Form Tool” section on www.nortonindustrial.com or ask your Norton representative for information on our made-to-order form tools for Jones & Lamson, Moore Pantograph, Hoglund, and Dia-Form Machines.

SPECcheck

CHISEL POINT TOOL MARKING SYSTEM

TOOL TYPE	INCLUDED ANGLE ON DIAMOND	RADIUS ON DIAMOND	CARAT WEIGHT	SHANK DIAMETER
CH = Natural Diamond	6 = 60°	05 = .005"	L = .10 - .15	6 = 3/8"
	7 = 75°	10 = .010"	M = .20 - .25	7 = 7/16"
	9 = 90°	15 = .015"	H = .33	
		20 = .020"	X = .50	
		25 = .025"		
		30 = .030"		

EXAMPLE: CH 9 5 M-6

TECHtip

CHISEL POINT TOOLS

Chisel Point Tools should be rotated 180° when dulling or contour problems occur.

Toolroom Tools

Norton Toolroom Dressing Tools are primarily used on surface grinders to form the grinding wheel to an exact concave or convex radius. Although some tools are designed for use on a specific machine, many radius tools can be used on any grinder having the correct set-up.

Used generally on 8" diameter and smaller vitrified toolroom wheels, Norton offers a selection of phono-point, conventional radius, and full ball radius tools.

WHEEL FORMS DRESSED BY THESE TOOLS



STRAIGHT



CONCAVE



CONVEX



MULTI-ANGLED



Phono-Point Tools

For general toolroom concave and convex dressing on small diameter grinding wheels. Not resettable.

INCLUDED ANGLE	SHANK DIAMETER	TOOL LENGTH	BETTER		GOOD	
			PRODUCT NO.	NON-RESETTABLE PART NO.	PRODUCT NO.	NON-RESETTABLE PART NO.
STOCK PHONO-POINT TOOLS						
60°	1/8"	1"	NP1M2	66260195225	BCPP-60	66260195017
	3/16"		NP1M3	66260195226		
	1/4"		NP1M4	66260195227		
75°	1/8"	1"	NP2M2	66260195228	BCPP-75	66260195018
	1/4"		NP2M4	66260195230		
90°	1/8"	1"	NP3M2	66260195231	BCPP-90	66260195019
	3/16"		NP3M3	66260195232		
	1/4"		NP3M4	66260195233		

STANDARD PACKAGE = ONE TOOL

WHEEL FORMS DRESSED BY THESE TOOLS



CONVEX



CONCAVE



CONVEX

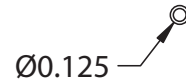
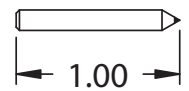

TYPICAL WHEEL FORMS

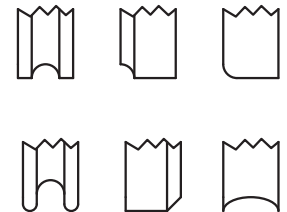

TECHtip

HOW TO USE TOOLROOM TOOLS

- We recommend dressing with coolant. However, if dressing totally dry, allow three to five seconds between passes for diamond to cool.
- Use extremely light cuts from .0002" to .001" maximum.
- Rotate tool if the application and set-up allow.
- Full Ball Radius Tools should be returned for relap after minimum wear.

SPECcheck

PHONO-POINT TOOL MARKING SYSTEM

TOOL TYPE	INCLUDED ANGLE ON DIAMOND	SHANK STYLE	SHANK DIAMETER
NP	1 = 60°	M	2 = 1/8"
BCPP	2 = 75°		3 = 3/16"
	3 = 90°		4 = 1/4"

EXAMPLE: NP 1 M 3

Toolroom Tools CONTINUED

Radius Tools

Concave Radius Tools

This line offers a specially-shaped single point diamond, designed for forming concave radii on small diameter grinding wheels. Not resettable.

Convex Radius Tools

This line offers a specially-shaped single point diamond, designed for forming convex radii on small diameter grinding wheels. Not resettable.

Half-Circle Concave Radius Tools (Available as Non-stock Only)

This line offers a specially-shaped diamond set in the side of the shank for forming half-circle radii on small diameter grinding wheels. The tool is rotated to form the radius. Commonly called a "rat tail dresser." Not resettable.

RADIUS SIZE TO BE DRESSED	SHANK DIAMETER	TOOL LENGTH	BEST		GOOD		
			PRODUCT NO.	NON-RESETTABLE PART NO.	TOOL LENGTH	PRODUCT NO.	NON-RESETTABLE PART NO.
STOCK CONCAVE RADIUS TOOLS							
.010" TO .015"	3/8"	3"	NR1P6	66260195210			
.016" TO .020"	3/8"	3"	NR2P6	66260195211			
.021" TO .032"	3/8"	3"	NR3P6	66260195212			
.033" TO .062"	3/8"	3"	NR4P6	66260195213	2"	BCRD	66260195016
.063" TO .125"	3/8"	3"	NR5P6	66260195214	2"	BCRD	66260195016
.126" TO .250"	3/8"	3"	NR6P6	66260195215	2"	BCRD	66260195016
STOCK CONVEX RADIUS TOOLS							
.020" TO .125"	3/8"	3"	NR2M6	66260195216			
.126" TO .250"	3/8"	3"	NR12M6	66260195217			
.251" TO .500"	3/8"	3"	NR25M6	66260195218			
NON-STOCK HALF-CIRCLE CONCAVE RADIUS TOOLS							
.032"	3/8"	2-1/2"	NR3N6	66260195219 NS			
.062"	3/8"	2-1/2"	NR6N6	66260195220 NS			
.125"	3/8"	2-1/2"	NR12N6	66260195221 NS			

STANDARD PACKAGE = ONE TOOL

NS NON-STOCK; CONTACT YOUR NORTON REPRESENTATIVE FOR CURRENT LEAD-TIMES.

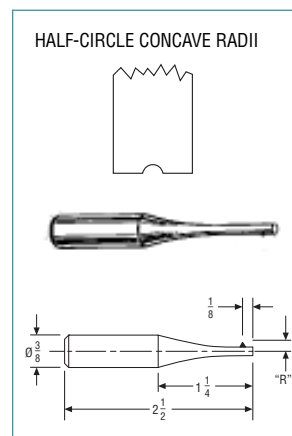
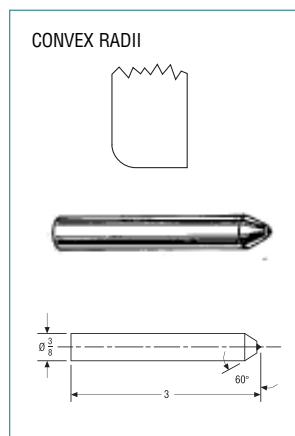
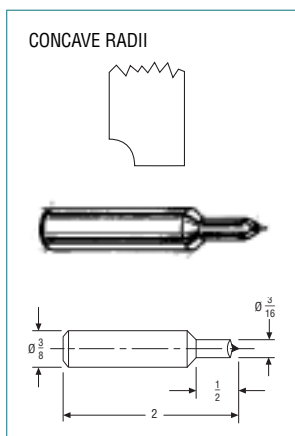

See the "Toolroom Diamond Dressing Tool" section on www.nortonindustrial.com or ask your Norton representative for information on our made-to-order full ball radius tools for precision plunge form dressing of concave radii in the center of a grinding wheel.

Cluster Tools

Norton Cluster Tools are designed specifically for straight face dressing of large diameter, coarse grit grinding wheels on single or double disc, centerless, or surface grinders.

WHEEL FORMS DRESSED BY THESE TOOLS



CONVEX



TAPERED



Multi-Point Cluster Tools

Multi-Point Cluster tools are typically used for straight face dressing on disc and centerless operations. For greatest efficiency, these tools should be mounted at a 15° angle so that three diamonds are in contact with the wheel face at all times. The tool should be rotated at frequent intervals. Not resettable.

BETTER

DIAMONDS ON FACE	SHANK DIAMETER	TOOL LENGTH	PRODUCT NO.	NON-RESETTING PART NO.
7	7/16"	1-5/16"	NC7K7	66260195206

STANDARD PACKAGE = 1 TOOL

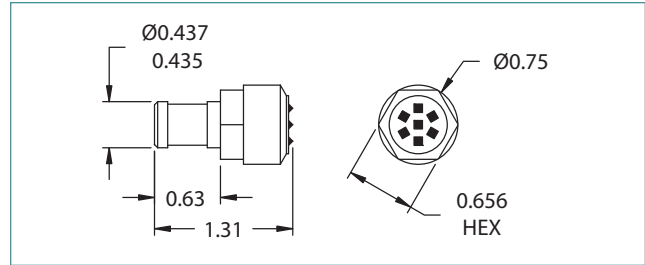

WHEEL FORMS DRESSED BY THESE TOOLS



STRAIGHT



TAPERED

Dia-Pak Tools

Dia-Pak tools are primarily used in straight face disc grinding, but are extremely versatile and may also be used in centerless and surface operations. Designed for maximum economy, three layers of diamond are carefully arranged so that a new layer is exposed before the previous layer is completely worn away. Not resettable.

BETTER

FOR WHEEL DIAMETERS	DIAMONDS PER LAYER	SHANK DIAM.	TOOL LENGTH	PRODUCT NO.	NON-RESETTING PART NO.
UP TO 14"	5-4-5	7/16"	2"	DP20	66260195200
UP TO 20"	7-6-7	7/16"	2"	DP30	66260195201
ANY	7-6-7	7/16"	2"	DP35	66260195202

STANDARD PACKAGE = 1 TOOL

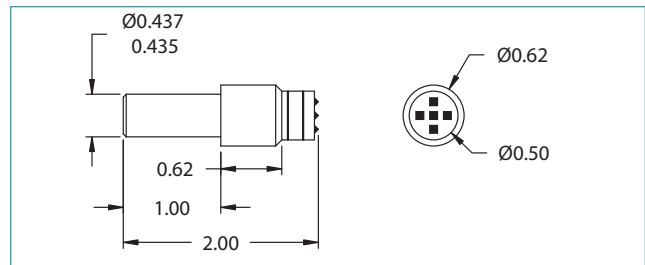

WHEEL FORMS DRESSED BY THESE TOOLS



STRAIGHT



TAPERED

TECHtip

CLUSTER AND DIA-PAK TOOLS – STRAIGHT FACE DRESSING OF HARD / COARSE WHEELS:

- Tool should approach the wheel at a 15° angle and be rotated periodically to keep three diamonds in contact with the wheel at all times.
- Tools can also be used at a 90° to the wheel face.
- Multi-Point Cluster Tools should be rotated at frequent intervals.
- Infeed per pass should not exceed .0015" (.001" with ceramic – Norton SG, Quantum, Targa TG, etc. – wheels).
- Use coolant whenever possible.
- These tools permit a faster traverse rate providing a freer cutting wheel than when dressed by a conventional single-point tool.



Accessories

Tool holders typically used in toolroom applications.

Tool Holder/Hand Dresser

Designed for use when offhand truing and dressing on tool and cutter, or benchstand grinders. This stock hand dresser will not rust, and is 10-1/2" long, with a hollow shaft that accepts any tool shank length from 3/4" to 9". The 1-3/4" diameter plastic knob ensures a firm grip. The collet accepts a 7/16" diameter tool shank.

DESCRIPTION	PART NUMBER
Hand Dresser	66260195020

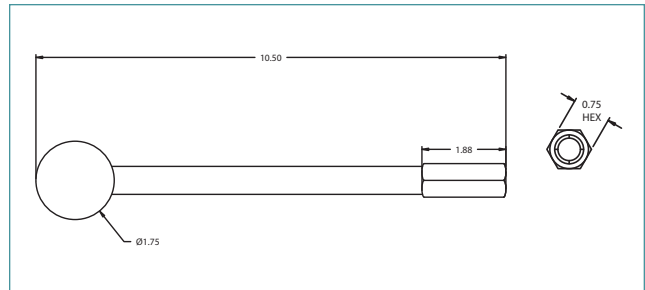

Machine Tool Holder

Designed to be mounted directly on the table of surface and tool grinders with a bolt or magnetic chuck, our stock machine dresser is positioned vertically with the tool positioned at a 15° drag angle.

DESCRIPTION	PART NUMBER
Machine Holder	66260195355

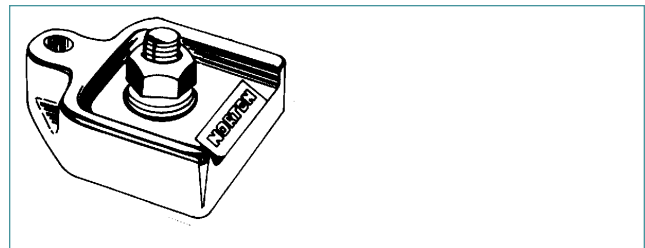

CATEGORY DEFINITION

Open or Closed Dressing... You Can Count on Fliesen Tools

Whether dressing a wheel OPEN or CLOSED you can count on Fliesen tools. Open wheels (sharp, free-cutting abrasive grains are exposed) are created by increasing the speed a Fliesen tool moves across the wheel when dressing. Generally considered the most favorable wheel conditioning, open wheels avoid workpiece burn while maximizing a wheel's ability to remove metal quickly when grinding.

Slowing a Fliesen tool as it moves across the wheel creates a closed wheel condition (abrasive grains are smoother, less sharp), a very helpful condition when trying to lower part surface finish readings.

- Harder, H-bond metal formulation tools efficiently dress durable silicon carbide and ceramic wheels.
- Furioso Fliesen tools have a unique bond system developed for dressing Quantum (NQ) ceramic wheels.
- W-bond Fliesen tools are designed for conventional aluminum oxide wheels.



The Benefits of Fliesen Tools

Spend More Time Grinding

Single point, chisel, and cone point tools require operator attention to ensure proper tool rotation at regular intervals. Fliesen tools require no adjustments. Simply install the tool, dress the wheel to break it in, and the tool will do the rest. Operators spend more time grinding – rather than making non-productive dressing adjustments.

Longer Tool Life

Expect long life when using a Fliesen tool. Other stationary tools, made with a single diamond stone, develop flat spots (“wear flats”) over time – which create chatter and burn. Fliesen tools use hand-set, fine diamond grit, eliminating the creation of wear flats.

Fliesen Tool Configurations: Plate and Shank

Fliesen tools are available in two basic tool configurations. The most common is a plate configuration, which is somewhat rectangular-shaped with a mounting hole. Fliesen Shank Tool configurations are plates mounted in shanks of varying sizes and shapes. Most grinding machines accommodate one or the other tool configuration. To find the correct tool configuration for your machine, check the existing dressing tool, or consult your grinding machine manual.

Choosing The Correct Fliesen Tool

Fliesen tools are precisely engineered to impart specific wheel forms. This chart illustrates those various wheel forms and corresponding Fliesen tool diamond positions. See the “Fliesen Tool” section on www.nortonindustrial.com or ask your Norton representative for complete product listing and information on these tools.

DESIRED WHEEL FORM					
DIAMOND POSITIONS					
	BLADE ONLY FR	SIDE-MOUNTED FRS, FAS, FBS, FCS, FDS	CENTER-MOUNTED FAS, FBS, FCS & FDS	DOUBLE-SIDED FCSD & FDSD	TWIN FDST, FSST, AND 1TFAS

Need Assistance Ordering Fliesen Tools?

Our customer service teams are ready to assist you. To expedite the process, please have this information on-hand when you call: the diameter, width, grit size, and abrasive type (aluminum oxide, silicon carbide, or ceramic) of the grinding wheel you will be dressing.



Furioso Tools

The new generation of highly wear-resistant stationary diamond dressing tools for dressing modern ceramic abrasives

Performance Advantage

Furioso vs. Standard Blade

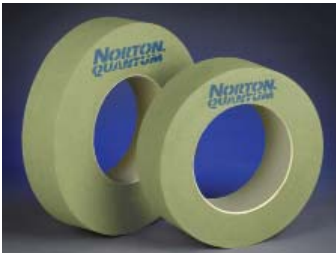
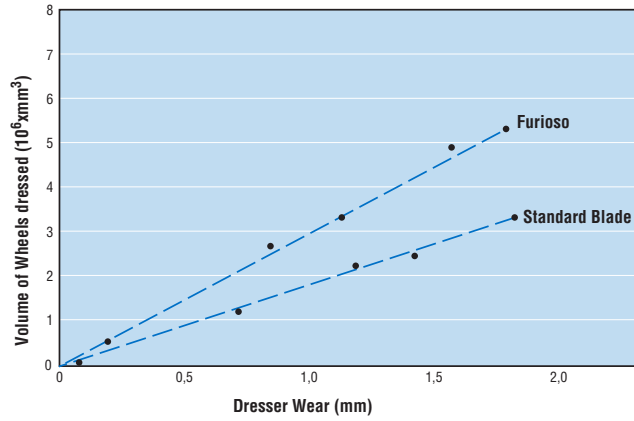

FURIOSO TOOLS

**BEST CHOICE FOR OPTIMUM PERFORMANCE OF
NORTON QUANTUM CERAMIC WHEELS**

FEATURES

- The optimized combination of diamond quality, bond and setting pattern when dressing Norton Quantum (NQ) ceramic grinding wheels

BENEFIT

- Improved wear-resistance
- Excellent dressing behavior
- Constant surface roughness

Standard Furioso Plate Drawings

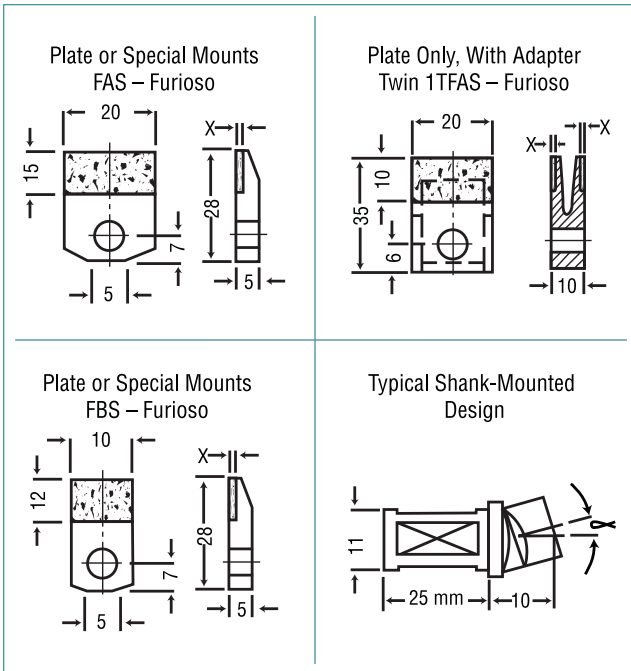

These two pages highlight a small sample of our Fliesen tool offering.

See the "Fliesen Tool" section on www.nortonindustrial.com or ask your Norton representative for complete product listing and information on these tools.



Furioso Plates; Side-Mounted and Twin

Use the Wheel/Tool Graph to identify your grinding wheel's Zone number, and the chart below to find the Furioso tool for your application.

Wheel / Furioso Tool Graph

Select Zone based on wheel diameter and width

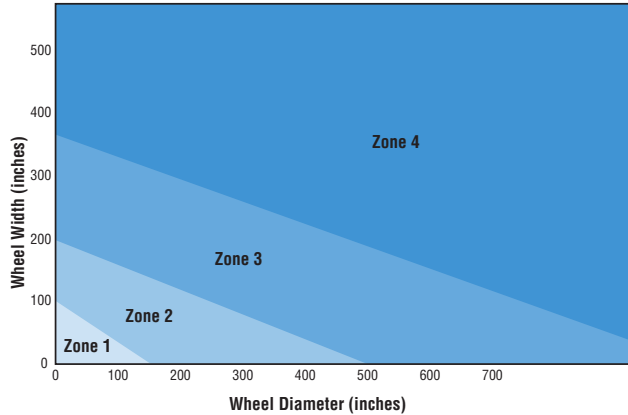

NORTON
POWERED BY
WINTER
TECHNOLOGY

		BEST		
ZONE NO. / SERIES	WHEEL GRIT SIZE	NORTON QUANTUM NQ CERAMIC WHEELS TOOL NO.	PART NO.	DESCRIPTION
SIDE-MOUNTED				
	ZONE 2			
	FBS Series	36 - 54	DT1463	69014122948• FBS 140 Furioso
		54 - 80	DT1462	69014122947• FBS 115 Furioso
		80 - 120	DT1461	69014122946• FBS 90 Furioso
	120 - 180	DT1460	69014122944• FBS 75 Furioso	
	ZONE 3			
	FAS Series	36 - 54	DT1467	69014122952• FAS 140 Furioso
		54 - 80	DT1466	60157690579• FAS 115 Furioso
		80 - 120	DT1465	60157693885• FAS 90 Furioso
	120 - 180	DT1464	69014122950• FAS 75 Furioso	
TWIN				
	ZONE 4			
	1TFAS Series	36 - 54	DT1471	69014122956• 1TFAS 140 Furioso
		54 - 80	DT1470	69014122955• 1TFAS 115 Furioso
		80 - 120	DT1469	69014122954• 1TFAS 90 Furioso
	120 - 180	DT1468	69014122953• 1TFAS 75 Furioso	

• ALL FURIOSO PLATES SHOWN SHIP IN 10 BUSINESS DAYS FROM RECEIPT OF ORDER.

SPECcheck

BLADE SIZE

DESCRIPTION	DIMENSION
1 FBS	10 mm thick, 15 mm usable length
2 FAS	20 mm thick, 15 mm usable length
3 TFAS	Twin blade with cooling duct

DIAMOND GRIT SIZE

DESCRIPTION	FEPA
140	D1181
115	D1001
90	D711
75	D501

Furioso Shank Tools

Made-to-order Furioso shank tools are also available. Ask your Norton representative for ordering assistance.

Side-Mounted Diamond Sections

Tools are available in different offset positions and angles.



OFFSET LEFT, SPECIFY ANGLE AMOUNT



ZERO OFFSET



OFFSET RIGHT, SPECIFY ANGLE AMOUNT



DIAMOND TIPPED LEFT, SPECIFY ANGLE



DIAMOND TIPPED RIGHT, SPECIFY ANGLE



THERE ARE MANY DIFFERENT DIAMONDS MAKING UP A SINGLE PLATE AS THIS CUT-AWAY VIEW SHOWS.

Tipping the Diamond Plates on Shank Tools

Diamond sections can be tipped right or left.





NORTON
SAINT-GOBAIN

NORTON
POWERED BY
WINTER
TECHNOLOGY

 **NORTON**
SILVER
EAGLE



CATEGORY DEFINITION

The Norton stock “99” line includes 250+ USA-made, ISO-certified, diamond and cBN products – for stock removal to tight-tolerance, precision finishing applications. Premium, high-performance resin bond diamond and cBN wheels are also available.

APPLICATIONS:

Norton B99 Diamond Wheels

- Sharpening cemented carbide cutting tools
- Cutting off carbide rod
- Grinding or cutting off non-ferrous materials such as ceramics or glass
- Surface grinding dies
- O.D. grinding spray coatings

Norton B99 cBN Wheels

- Sharpening high-speed (M2, D2, T15, etc.) steel cutting tools
- Surface and ID grinding hardened steel die components
- Precision grinding steel parts Rc 50 or harder

STOCK SHAPES:

DW Mounted Points, HH1 and HH2 Hand Hones, and 1A1, 1A1R, 1V1P, 4A2P, 6A2C, 6A2H, 11A2, 11V9, 12A2, 12V9, and 15V9 Wheels

ABRASIVE GRAIN:

Diamond and cBN (cubic Boron Nitride)

ABRASIVE BONDS:

Resin, Metal, Metal Single Layer, and Vitrified

STOCK DIAMOND WHEELS

FEATURES

- High quality synthetic diamond
- Pre-engineered resin bond – B99
- Premium, heavy-duty resin bond – B105
- Metal bond – M99
- MSL (metal single layer) diamond tools; no wheel dressing required
- Vitrified bond – V99

BENEFITS

- High material removal rates; longer wheel life vs. conventional green silicon carbide wheels
- Free cutting; superior form holding; efficient wet or dry
- Ideal for dry toolroom reconditioning applications
- Ideal for 1A1R cut-off applications and grinding glass or ceramic materials
- Fast stock removal, cool cutting; excellent for dry offhand finishing of carbide
- Most durable under high grinding forces; excellent for wet, offhand finishing of carbide tools

STOCK cBN WHEELS

FEATURES

- cBN (cubic Boron Nitride) abrasive material is second in hardness to diamond
- Pre-engineered resin bond – B99
- Premium Aztec III resin bond
- Premium Aztec .007 resin bond

BENEFITS

- Easily cuts difficult-to-grind steel parts Rc 50 or harder
- Highly wear resistant and thermally stable
- Free cutting, superior form holding
- Most efficient for dry tool resharpener
- Most efficient for dry tool resharpener where heavy stock removal is desired

TECHtip

- Truing makes the wheel concentric with the spindle.
- Dressing opens the wheel's cutting face.
- Always true and dress diamond and cBN wheels prior to use.
- Diamond and cBN wheels with grit sizes 100 – 180 can be trued with a Brake Controlled Truing Device.
- Refer to the “Mounting, Truing and Dressing Guide” for more information.



It is the user's responsibility to refer to and comply with ANSI B7.1

NORTON DIAMOND PRODUCT IDENTIFICATION SYSTEM / USAGE INFORMATION

ASD 120 – R 75 B99 1/8

ABRASIVE TYPE	GRIT SIZE	GRADE	CONCENTRATION	BOND	ABRASIVE DEPTH
ASD <ul style="list-style-type: none"> Used with B99 and B105 bonds Armored Durable Versatile Wet or dry Carbide/steel operations 	<ul style="list-style-type: none"> 100S – Roughing 120 – Roughing/cutting-off 150 – Combined roughing and finishing 180 – Improving finish 220, 320 & 400 – Finishing only 10/20 mic 6/12 mic 	Resin Bond R – Norton standard N – Free cutting Metal Bond N – Norton standard Vitrified Bond P – Norton standard R – Most durable	50 <ul style="list-style-type: none"> Most economical For broad area of contact 75 <ul style="list-style-type: none"> Norton standard Freer cutting than 100 Dry grinding with ASD 100 <ul style="list-style-type: none"> Very durable For flood coolants Use with 220 grit or finer Use for cutting-off 115 <ul style="list-style-type: none"> For CNC grinding machines 125 <ul style="list-style-type: none"> Form holding For high volume, high pressure coolant, precision applications on high-speed tool steels 	B99 <ul style="list-style-type: none"> Resin bond Wet or dry Tool making; resharpening B105 <ul style="list-style-type: none"> Premium resin bond Advanced heat-reducing bond Dry; reconditioning B610 and B80 <ul style="list-style-type: none"> For CNC grinding machines M99 <ul style="list-style-type: none"> Metal bond 1A1R cut-off Glass and ceramics MSL <ul style="list-style-type: none"> Metal single layer Type 6A2C only Dry Offhand reconditioning/finishing carbide V99 <ul style="list-style-type: none"> Vitrified bond Offhand finishing of carbide tools Plunge grinding 	1/16" 1/8" 1/4" 9/32" 3/8" 1/2" (New!) 3/4" solid
CD <ul style="list-style-type: none"> Used with B99 bond 					
D <ul style="list-style-type: none"> Used with B99 bond Micron-sized diamond; finishing 					
M3D <ul style="list-style-type: none"> Used with M99 bond 					
M4D <ul style="list-style-type: none"> Used with M99 bond Armored Durable; for non-metallics 					
RMD <ul style="list-style-type: none"> Used with V99 bond 					
SD <ul style="list-style-type: none"> Used with B99 and V99 bonds Norton standard Wet or dry Free cutting Low horsepower (3/4 hp or less) 					

NORTON cBN PRODUCT IDENTIFICATION SYSTEM / USAGE INFORMATION

CB 120 – T B99 1/8

ABRASIVE TYPE	GRIT SIZE	GRADE	BOND	ABRASIVE DEPTH
CB – cubic Boron Nitride <ul style="list-style-type: none"> Used with B99 bond Armored Wet or dry 	<ul style="list-style-type: none"> 100 – Roughing 120 – Roughing/cutting-off 150 – Combined roughing and finishing 180 – Improving finish 220, 320, 400 – For finishing only 	Q <ul style="list-style-type: none"> Approx. 50 concentration Type 6A2 Broad area of contact T <ul style="list-style-type: none"> Approx. 75 concentration Norton standard First choice Lower horsepower Broad area of contact Dry grinding Resharpening applications W <ul style="list-style-type: none"> Approx. 100 concentration Most durable High volume coolant Flute polishing Surface grinding Cylindrical grinding 	B99 <ul style="list-style-type: none"> Resin bond Wet or dry BXD3037 and WBB & WBE <ul style="list-style-type: none"> For CNC grinding machines Aztec III <ul style="list-style-type: none"> Premium resin bond Dry Tool resharpening Aztec .007 <ul style="list-style-type: none"> Premium resin bond Dry Increased feed rates Heavy stock removal Heavier cuts 	1/16" 1/8" 1/4" 1/2" (New!) Solid

HOW TO SELECT NORTON STOCK DIAMOND WHEELS

SELECT

WHEEL DIMENSIONS	<p>D x T x H Select Diameter x Thickness x Hole from the availability tables. Use blueprint numbers where available.</p>	
ABRASIVE	<p>RESIN BOND WHEELS: ASD Armored diamond, durable. Versatile: can be used wet or dry. Also should be used when carbide and steel are ground in the same operation. D Micron-sized diamond. Used for finishing and polishing operations. SD Free cutting standard. Used wet or dry; should be used on low horsepower (3/4 hp or less) machines.</p> <p>METAL BOND WHEELS: M4D Armored, durable standard. A strong, blocky crystal designed for high performance on glass, ceramics, refractories and other non-metallics.</p> <p>VITRIFIED BOND WHEELS: RMD Medium strength. Specifically designed for use with vitrified bonds. SD Free cutting standard.</p>	<p>Select the abrasive based on horsepower, grinding wet or dry, and contact with steel.</p>
GRIT SIZE	<p>100 Roughing. The most common grit size for roughing operations. 120 For roughing where 100 is too coarse. Also for cut-off applications. 150 Medium stock removal plus good finish. For combined roughing and finishing applications. 180 Medium stock removal plus good finish. To improve finish. 220 Finishing 320 Finishing 400 Fine Finishing 10/20 Mic Super Fine Finishing 6/12Mic Super Fine Finishing</p>	<p>Select the abrasive grit size based on finish and material removal rate required.</p>
GRADE	<p>RESIN BOND WHEELS: R Norton standard N Free cutting</p> <p>METAL BOND WHEELS: N Norton standard</p> <p>VITRIFIED BOND WHEELS: P Norton standard R Most durable</p>	<p>The hardness of the wheel</p>
CONCENTRATION	<p>50 Most economical. For broad area of contact grinding. 75 Norton standard. Freer cutting than 100 and the most economical for dry grinding with ASD diamond. 100 Very durable. Recommended under flood coolant conditions; for use with 220 grit or finer, when durability is required, and for cut-off applications. 125 Form holding. Used in high volume, high pressure coolant, precision applications on high-speed tool steels.</p>	<p>Select the abrasive concentration based on grinding wet or dry, material removal rates and form-holding requirements.</p>
BOND	<p>RESIN BOND: B99 Norton standard. Versatile enough to be used wet or dry on most tool making or resharpening applications. B105 Premium, heat-reducing bond. For dry toolroom reconditioning applications.</p> <p>METAL BOND: M99 Best suited for 1A1R cut-off applications as well as grinding glass or ceramic materials. MSL Metal Single Layer. Available in shape 6A2C for dry, offhand reconditioning of carbide tools.</p> <p>VITRIFIED BOND: V99 Best for wet offhand finishing of carbide tools as well as plunge grinding of carbide tools.</p>	<p>Select the bond based on the material being ground and grinding application.</p>
ABRASIVE DEPTH	<p>1/16 1/8 1/4 9/32 Solid</p>	<p>Usable abrasive</p>

HOW TO SELECT NORTON STOCK cBN WHEELS

SELECT

WHEEL DIMENSIONS	D x T x H Select Diameter x Thickness x Hole from the availability tables. Use blueprint numbers where available.	
ABRASIVE	CB Norton standard coated cBN (cubic Boron Nitride). Optimized for high performance in resin bond systems.	Select Norton cBN abrasive to grind hard tool steels such as A2, D2, T15, etc., and tough alloy steels.
GRIT SIZE	100 Roughing. The most common grit size for roughing operations. 120 For roughing where 100 is too coarse. Also for cut-off applications. 150 Medium stock removal plus good finish. For combined roughing and finishing applications.	Select the grit size based on finish and material removal rate required.
GRADE	T Norton standard. Approximately 75 concentration. T is the first choice for lower horsepower equipment or large area of contact between the wheel and the work piece. Ideal for resharpening applications with 11V9, 12A2, 4A2P, and 15V9 wheel shapes when dry grinding. W Most durable. Approximately 100 concentration, W is recommended for high volume coolant operations: flute grinding from solid, flute polishing, surface, and cylindrical grinding.	The hardness of the wheel
BOND	B99 Norton standard. Pre-engineered for optimal performance with cBN abrasive. Available in all shapes. Aztec III The Norton advanced heat-reducing, lubricating resin bond. Used for dry grinding tool steels. Aztec .007 The Norton premium resin bond for increased feed rates, high stock removal and heavier cuts – when dry grinding tool steels.	Select the bond depending on the type of grinding application.
ABRASIVE DEPTH	1/16 1/8 1/4 Solid	Usable abrasive

TECHtip

DIAMOND GRINDS:

In general, diamond is used to grind non-ferrous materials, because of an adverse reaction between diamond and iron.

- Cemented carbide
- Glass
- Ceramics
- Fiberglass
- Plastics
- Stone
- Abrasives
- Electronic components and materials

cBN GRINDS:

cBN is used to grind ferrous materials.

- High-speed tool steels
- Die steels
- Hardened carbon steels
- Alloy steels
- Aerospace alloys
- Hardened stainless steel
- Abrasion-resistant ferrous materials

Norton offers a comprehensive stock product selection to service most of your needs – with the fastest delivery and lowest prices.

- Review this stock section first. If you can not find the specification you need:
- Then refer to the brief descriptions of our Norton/Winter toolroom, B99 Express, CNC, and saw grinding lines, (following this section)
- See the “Diamond and cBN” product group on www.nortonindustrial.com or contact your Norton representative for a complete listing of these stock and made-to-order superabrasive products.



It is the user's responsibility to refer to and comply with ANSI B7.1

APPLICATION-TO-PRODUCT RECOMMENDATION GUIDE – DIAMOND WHEELS

APPLICATION OR COMMON MACHINE TYPE	COMMON WHEEL SIZE, TYPE & BLUEPRINT	APPLICATION VARIABLES	RECOMMENDED SPECIFICATION
CARBIDE GRINDING – TOOLROOM PRODUCTION			
Blanchard Grinding • Vertical Spindle Surface Grinding	10", 11", 16" & 18" diameters Type 2A2T	Wet – solid carbide • 1" or larger pieces – roughing • Small pieces	SD100-R75B99E* ASD100-R75B99E*
Hand • Burr Grinding	6" x 3/32" x 1-1/4" Type 1V1P V – 20° ME89562	Dry	ASDC320B-R125B99
Centerless (wet) • Throughfeed Grinding	12", 14", 16", 18" & 20" diameters Type 1A1	Roughing	ASD100-R75B99E*
• Unison Dedtru Grinder	7" x 1" x 1-1/4" Type 1A1		ASD150-R75B99E*
Cutting Off (wet)	6" x .035" x 1-1/4" Type 1A1R ME43572 10" x .050" x 1-1/4" Type 1A1R ME43565	• Most durable • Free cutting	ASD100S-R100B99 SD100-R75B99 SD120-R100B99
Cylindrical Grinding (wet)	10", 12", 14", 16" & 20" diameters Type 1A1	• Wet, rough grinding of cemented carbides, hard (55 Rc+) plasma and ceramic spray coatings • Wet, finish grinding of all carbides, plasma and ceramic spray coatings	ASD180-R100B99 ASD180-R75B99E* ASD150-R75B99 ASD120-R75B99 SD220-R100B99E*
Tool Sharpener Grinder (wet) • Bench Type	5" x 1" x 1-1/4" Type 6A2H ME27084 Rim Width (W) = 1-1/16	Tool sharpening	SD320-R50B99
Hand Honing (dry)	Various sizes Type HH1 or HH2		ASD100-R100B99 SD320-100V99
Lamination Dies (wet)	Various sizes Type 1A1	Surface grinding of carbide	ASD120-R75B99
Surface Grinding (wet) • Straight Wheels	Various sizes Type 1A1	Roughing • Durable • Free cutting Finishing only General purpose	ASD100S-R100B99E* SD100S-R100B99 SD220-R100B99 ASD150-R75B99
Tool & Cutter Grinding	Various sizes Type 11V9, 12V9 or 15V9	Wet or dry	ASD120-R7599
CARBIDE GRINDING – OFFHAND			
Single-Point Carbide Tools	6" x 3/4" x 1-1/4" Type 6A2C ME27853	Wet roughing • Durable • Free cutting Wet finishing • Durable • Free cutting Wet or dry grinding where free-cutting and self-dressing wheels are required • Roughing • Finishing	RMD150-P50V99* SD150-P50V99 RMD220-P50V99* SD220-P50V99 ASD120-R75B99 SD220-R50B99E*

NOTE: DIAMOND DEPTHS ARE NOT INDICATED IN ABOVE LISTINGS. WHEN ORDERING, BE SURE TO INCLUDE DIAMOND DEPTH (1/16, 1/8, ETC.).

*EXPRESS MADE-TO-ORDER; REFER TO THE B99E EXPRESS MADE-TO-ORDER WHEEL SECTION.

APPLICATION-TO-PRODUCT RECOMMENDATION GUIDE – cBN WHEELS

APPLICATION OR COMMON MACHINE TYPE	COMMON WHEEL SIZE, TYPE & BLUEPRINT	APPLICATION VARIABLES	RECOMMENDED SPECIFICATION
TOOLROOM GRINDING			
Cutter Sharpening • Milling Cutters, Broaches, Reamers, etc.	3-3/4" x 1-1/2" x 1-1/4" Type 11V9 ME92192	Dry Wet	Aztec III 120T CB120-TB99
	6" x 1" x 1-1/4" Type 12A2 ME27758	Wet or dry	CB120-TB99
	6" x 3/4" x 1-1/4" Type 12V9 ME48666	Wet or dry	CB120-TB99
	6" x 3/4" x 1-1/4" Type 15V9 ME40633	Wet or dry	CB100-WB99E*
Surface Grinding	10" x 1/2" x 3" Type 1A1	Wet or dry	CB100-TB99E*
Cylindrical Grinding	12" x 1/2" x 3" Type 1A1	Wet or dry	CB150-WB99E*
Internal Grinding Tools	Thinner than 1/2" Type DW	Wet or dry	CB100-WB99
	1/2" or thicker Type 1A1	Wet or dry	CB120-TB99E*
Slotting	7" x .040" x 1-1/4" Type 1A1R	Water-base coolant	CB120-WB99E*

NOTE: cBN DEPTHS ARE NOT INDICATED IN ABOVE LISTINGS. WHEN ORDERING, BE SURE TO INCLUDE CBN DEPTH (1/16, 1/8, ETC.)

*EXPRESS MADE-TO-ORDER; REFER TO THE B99E EXPRESS MADE-TO-ORDER WHEEL SECTION.

CROSS REFERENCE GUIDE

	NORTON										
	ABRASIVES				BONDS						
	RESIN DIAMOND ASD	RESIN DIAMOND SD	METAL DIAMOND M4D	RESIN/VITRIFIED cBN CB	RESIN DIAMOND B99/B99E	RESIN DIAMOND B105	METAL DIAMOND M99	VITRIFIED DIAMOND V99	RESIN cBN B99/B99E	RESIN cBN B99EF	RESIN cBN AZTEC
3M / General Industrial Diamond / Diamond Productions, Inc	CGD, ND	GD, D, MD		CB	PS			V		BC	
Abrasive Technology	SN	S		cBN	B		M		B		
Accurate Diamond Tool	NCD	D, MD		BN	B		M				
Citco	5SD, 6SD	SD	MD	CB	B43, B52		M		B26	C3	
Engis	NMD	D, MD		cBN, CB							
Noritake				CBC		BX4			BD/B38		BX4
Radiac / US Diamond	NCD, WD, 1WD, MDC	D, MD	MD4C	B, CB, BZ	B7Z, BB, B5, B56, BN		M, MF	V	BZ, BN		
Regal Diamond				B, BB	BJ						
Superabrasives, Inc.	MDN	D, MD		B					B82	B5	
Tyrolit / Wickman / Bay State / Cincinnati	SDM, XDL, XDN, D, 7D, CMD	SD, D, 6D, MD	1D	5B, 1BN, BN, BM	BD, BC, BX33, B52, B6	Amigo	MI, MSS, MB		B72, B56, BG, B7	BXU8	Amigo
Wendt / Stip Naxos / Winterthur	SDK			B, BXW					RN	RR	

TROUBLESHOOTING GUIDE – DRY GRINDING

PROBLEM	POSSIBLE CAUSES	SUGGESTED CORRECTION
Burning (excessive heat)	Wheel loaded or glazed Excessive feed rate Wheel too durable	Dress wheel with a dressing stick Reduce infeed of wheel or workpiece Use freer cutting specification or slow down wheel speed
Poor finish	Grit size too coarse Excessive feed rate	Select a finer grit size Reduce infeed of wheel or workpiece
Chatter	Wheel out of truth	True wheel; ensure it is not slipping on mount (See “Mounting, Truing and Dressing Guide”)

TROUBLESHOOTING GUIDE – WET GRINDING

PROBLEM	POSSIBLE CAUSES	SUGGESTED CORRECTION
Burning (excessive heat)	Wheel glazed or loaded Poor coolant placement Excessive material removal rate	Re-dress wheel Apply coolant directly to wheel/workpiece interface Reduce downfeed and/or crossfeed
Poor finish	Excessive dressing Grit size too coarse Poor coolant flow or location	Use lighter dressing pressure Stop dressing as soon as wheel starts to consume stick rapidly Select a finer grit size Apply heavy flood so it reaches wheel/work interface
Chatter	Wheel out of truth	True wheel; ensure it is not slipping on mount
Wheel will not cut	Glazed by truing Wheel loaded	Dress lightly until wheel opens up Dress lightly until wheel opens up Increase coolant flow to keep wheel surface clean Never run wheel with coolant turned off
Slow cutting	Low feeds and speeds	Increase feed rate; increase wheel speed (Do not exceed wheel MOS)
Short wheel life	Incorrect coolant flow Low wheel speed Excessive dressing Wheel too soft or too hard	Apply coolant to flood wheel/work surface Increase wheel speed (observe maximum operating speed) Use lighter dressing pressure Change grit or grade; use higher concentration

MATERIAL HARDNESS SCALE

Superabrasives is a term used to describe those abrasives of extreme hardness which produce outstanding results when properly used on specific applications. The following chart provides a hardness comparison (Knoop Hardness Scale) between diamond and cBN superabrasives, aluminum oxide and silicon carbide standard abrasives, and some common materials these abrasives are used to grind.

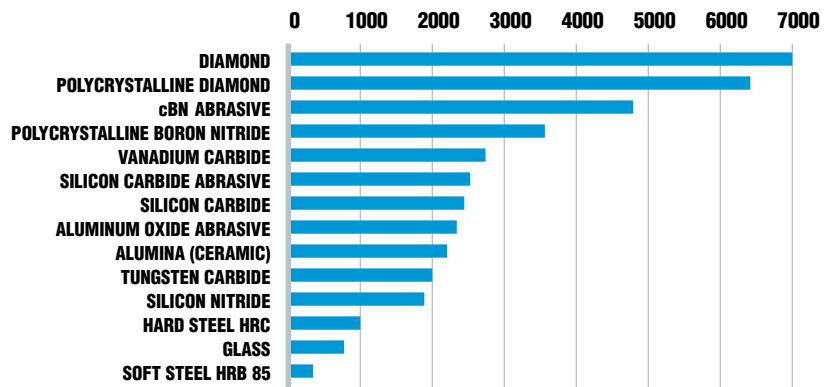

TECHtip

AVOID GRINDING STEEL

- Avoid steel when grinding with diamond wheels. Keep the amount of steel ground to an absolute minimum.
- On brazed tools, use aluminum oxide wheel to back off the steel shank.
- A high lubricity grinding fluid should be used.
- For some steels, an armored (AMD) diamond wheel may prove most economical.

USE RIGID WORK SUPPORT

- All workpieces should be supported firmly during the grinding process. Any amount of vibration will cause wheel wear and produce chatter or wave marks on the ground surface.
- On work ground between centers, centerholds should be properly prepared.
- Minimize work overhang.
- If the ground work is supported by a work finger, ensure the finger is strong enough to provide vibration-free support.

COOLANT – GRIND WET

- Diamond wheels should be used with a full flood coolant properly directed toward the grinding zone. Water with a rust inhibitor is recommended.
- Vitrified diamond wheels should be used only with a coolant.
- When flood application can't be used, try mist or spray application.
 - Use compressed air to “atomize” water or soluble oil.

- Direct the spray at the grinding zone to help dissipate heat and prevent heat damage to the work.

AVOID EXCESSIVE FEEDS

- Excessive feeds will result in premature wheel wear. Excessive feed rates are characterized by:
 - A hard grinding sound
 - Chatter
 - Burn
 - High wheel wear rate
 - Vibration

Decimal and Metric Equivalents of Common Fractions

FRACTIONS OF AN INCH	DECIMALS OF AN INCH	MILLIMETERS
1/64	.0156	0.397
1/32	.0313	0.794
3/64	.0469	1.191
1/16	.0625	1.588
5/64	.0781	1.985
3/32	.0938	2.381
7/64	.1094	2.778
1/8	.1250	3.175
9/64	.1406	3.572
5/32	.1563	3.969
11/64	.1719	4.366
3/16	.1875	4.762
13/64	.2031	5.159
7/32	.2188	5.556
15/64	.2344	5.953
1/4	.2500	6.350
17/64	.2656	6.747
9/32	.2813	7.144
19/64	.2969	7.541
5/16	.3135	7.937
21/64	.3281	8.334
11/32	.3438	8.731
23/64	.3594	9.128
3/8	.3750	9.525
25/64	.3906	9.922
13/32	.4063	10.319
27/64	.4219	10.716
7/16	.4375	11.112
29/64	.4531	11.509
15/32	.4688	11.906
31/64	.4844	12.303
1/2	.5000	12.700
33/64	.5156	13.097
17/32	.5313	13.494
35/64	.5469	13.891
9/16	.5625	14.287
37/64	.5781	14.684
19/32	.5938	15.081
39/64	.6094	15.478
5/8	.6250	15.875
41/64	.6406	16.272
21/32	.6563	16.688
43/64	.6719	17.085
11/16	.6875	17.462
45/64	.7031	17.859
23/32	.7188	18.256
47/64	.7344	18.653
3/4	.7500	19.050
49/64	.7645	19.447
25/32	.7813	19.843
51/64	.7969	20.240
13/16	.8125	20.637
53/64	.8281	21.034
27/32	.8438	21.430
55/64	.8594	21.827
7/8	.8750	22.224
57/64	.8906	22.621
29/32	.9063	23.018
59/64	.9219	23.415
15/16	.9375	23.812
61/64	.9531	24.209
31/32	.9688	24.606
63/64	.9844	25.003
1	1.0000	25.400

Expected Surface Finish by Grit Size

Use these charts as guides only. Surface finish is affected by several variables: machine type and condition, type of material ground, coolant, wheel speed, bond system, etc.

Diamond

GRIT SIZE	EXPECTED FINISH MICRO INCH AA	MAXIMUM DEPTH OF CUT PER PASS FOR GRIT SIZE
100	24 to 32	0.001" to 0.002"
120	16 to 18	0.001" to 0.002"
150	14 to 16	0.001" to 0.002"
180	12 to 14	0.0007" to 0.001"
220	10 to 12	0.0007" to 0.001"
320	8	0.0004" to 0.0006"
400	7 to 8	0.0003" to 0.0005"

cBN

GRIT SIZE	EXPECTED FINISH WITH OSCILLATION	EXPECTED FINISH PLUNGE
100	35 – 40	40 – 45
120	30 – 35	35 – 40
150	25 – 30	30 – 35
180	20 – 25	25 – 30
220	15 – 20	20 – 25
320	10 – 15	15 – 20
400	4 – 8	5 – 10

Recommended Wheel Speeds for Diamond and cBN Wheels

WET GRINDING

	CUP WHEELS	PERIPHERAL WHEELS
DIAMOND GRINDING WHEELS		
	11V9, 12V9, 15V9, etc.	1A1, 1V1, 1A1R, etc.
Resin Bond Wheels	4921 to 7874 SFPM 25 to 40 m/s	4921 to 7874 SFPM 25 to 40 m/s
Metal Bond Wheels		3937 to 5906 SFPM 20 to 30 m/s
Vitrified Bond Wheels	2953 to 5906 SFPM 15 to 30 m/s	2953 to 5906 SFPM 15 to 30 m/s
cBN GRINDING WHEELS		
Resin Bond Wheels	5906 to 9843 SFPM 30 to 50 m/s	5906 to 9843 SFPM 30 to 50 m/s

DRY GRINDING

	CUP WHEELS	PERIPHERAL WHEELS
DIAMOND GRINDING WHEELS		
	11V9, 12V9, 15V9, etc.	1A1, 1V1, 1A1R, etc.
Resin Bond Wheels	2756 to 3543 SFPM 14 to 18 m/s	2756 to 3543 SFPM 14 to 18 m/s
cBN GRINDING WHEELS		
Resin Bond Wheels	2953 to 5906 SFPM 15 to 30 m/s	2953 to 5906 SFPM 15 to 30 m/s

NOTE: THESE ARE NOT THE MAXIMUM OPERATING SPEEDS (MOS).

CONSULT ANSI B7.1 OR CONTACT YOUR NORTON REPRESENTATIVE FOR MOS.

Wheel Speed Calculation

To convert m/s to SFPM: **Multiply M/S x 196.85 = SFPM**

To convert SFPM to M/S: **Divide SFPM by 196.85 = M/S**

To convert RPM to SFPM: **Multiply wheel diameter in inches x RPM x 0.262**

M/S = METERS/SECOND RPM = REVOLUTIONS PER MINUTE SFPM = SURFACE FEET PER MINUTE

SIZE D X T	SPECIFICATION	PART NO.
TYPE DW MOUNTED POINTS – DIAMOND		
1/8 x 1/4 Steel Spindle 1/8 x 1-1/2	SD150-R100B99-SOLID SD220-R100B99-SOLID	69014192235 69014192236
3/16 x 1/4 Steel Spindle 1/8 x 1-1/2	SD100-R100B99-SOLID	69014192238
1/4 x 1/4 Steel Spindle 1/8 x 1-1/2	SD100-R100B99-SOLID	69014192240
3/8 x 1/4 Steel Spindle 1/8 x 1-1/2	SD100S-R100B99-SOLID	69014192243
1/2 x 1/2 Steel Spindle 1/4 x 1-1/2	SD100S-R100B99-SOLID SD220-R100B99-SOLID	69014192248 69014192249
3/4 x 3/8 Steel Spindle 1/4 x 1-1/2	SD150-R100B99-SOLID	69014192251
1 x 1/2 Steel Spindle 1/4 x 1-1/2	SD100-R100B99-SOLID	69014192428
TYPE DW MOUNTED POINTS – cBN		
3/16 x 1/4 Carbide Spindle .125 x 1-3/4	CB150-WB99-SOLID	69014192258
1/4 x 1/4 Carbide Spindle .125 x 1-3/4	CB120-WB99-SOLID	69014192260
3/8 x 3/8 Steel Spindle .250 x 2-1/4	CB100-WB99-SOLID	69014192266
1/2 x 1/2 Carbide Spindle .250 x 2-1/4	CB100-WB99-SOLID	69014192272
3/4 x 1/4 Carbide Spindle .250 x 2-1/4	CB100-WB99-SOLID	69014192276
1 x 1/4 Carbide Spindle .250 x 2-1/4	CB100-WB99-SOLID	69014192277
SIZE T X W X L	SPECIFICATION	PART NO.
TYPE HH1 HAND HONES – DIAMOND		
1/4 x 1/4 x 6 One 1/16 deep 1" long insert in one 1/4 surface	ASD220-R100B99-1/16	69014192139
1/4 x 3/8 x 4 One 1/16 deep 1" long insert in one 3/8 surface	ASD100-R100B99-1/16 ASD180-R100B99-1/16 ASD220-R100B99-1/16 ASD320-R100B99-1/16 ASD400-R100B99-1/16	69014192141 69014192142 69014191670 69014191672 69014192143
	D10/20MIC-R100B99-1/16 SD220-100V99-1/16 SD320-100V99-1/16	69014192144 69014191671 69014192140
TYPE HH2 HAND HONES – DIAMOND		
1/4 x 3/8 x 4 Two 1/16 deep 1" long inserts in one 3/8 surface	ASD120/220-R100B99-1/16 ASD150/320-R100B99-1/16 ASD220/320-R100B99-1/16 ASD220/400-R100B99-1/16 ASD320/400-R100B99-1/16	69014192150 69014192177 69014192178 69014192179 69014192180
1/4 x 7/16 x 4 Two 1/16 deep 1" long inserts in one 7/16 surface	SD220/320-100V99-1/16 SD320/400-100V99-1/16	69014192149 69014192182

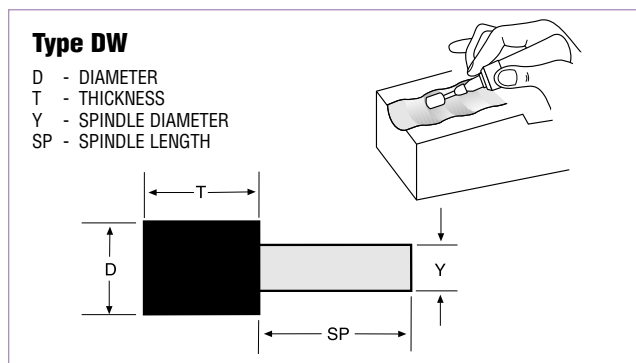

SIZE D X T X H	SPECIFICATION	PART NO.
TYPE 1A1 STRAIGHT – DIAMOND		
3/4 x 1/4 x 1/4	ASD150-R100B99-1/8	69014192174
1 x 1/4 x 1/4	SD100-R100B99-1/8	69014192175
1-1/2 x 1/2 x 1/2	D6/12MIC-N100B99-1/8	69014192176
2 x 1/8 x 1/4	SD100-R100B99-1/8	69014192184
3 x 1/4 x 3/4	SD180-N100B99-1/8	69014192187
4 x 1/32 x 1-1/4	SD100S-R100B99-1/4	69014192192
4 x 1/16 x 1-1/4	SD100S-R100B99-1/4 SD150-R100B99-1/4 SD220-R100B99-1/4	66260273583 66260273584 66260273586
4 x 1/8 x 3/4	SD150-R100B99-1/4	69014192024
4 x 1/8 x 1-1/4	SD150-R100B99-1/4	69014191677
4 x 1/4 x 1/2	SD150-R100B99-1/4	66260273590
4 x 1/4 x 3/4	SD150-R100B99-1/4	66260273592
4 x 1/4 x 1-1/4	SD100S-R100B99-1/4 SD120-R100B99-1/4 SD150-R100B99-1/4	66260273587 66260273588 66260273589
4 x 1/2 x 1-1/4	SD150-R100B99-1/4	66260273594
6 x 1/32 x 1-1/4	SD220-R100B99-1/4	69014192197
6 x 1/16 x 1-1/4	SD100-R100B99-1/4 SD150-R100B99-1/4 SD180-R100B99-1/4 SD220-R100B99-1/4	66260273596 66260273597 66260273598 66260273599
6 x 1/8 x 1-1/4	ASD150-R75B99-1/4 SD100-R100B99-1/4 SD120-R100B99-1/4 SD150-R100B99-1/4 SD180-R100B99-1/4 SD220-R100B99-1/4	66260273617 66260273611 66260273612 66260273613 66260273614 66260273615
6 x 1/4 x 1-1/4	ASD100S-R75B99-1/4 ASD120-R75B99-1/4 ASD150-R75B99-1/4 ASD180-R75B99-1/4 ASD220-R75B99-1/4 ASD320-R75B99-1/4 RMD180-P100V99-1/8	69014192205 69014192769 66260273609 69014192770 69014192771 69014192772 69014192203
	SD120-R100B99-1/4 SD150-R100B99-1/4 SD180-R100B99-1/4 SD220-R100B99-1/4	69014191691 69014191692 69014191693 69014192764
6 x 3/8 x 1-1/4	ASD120-R75B99-1/4 ASD150-R75B99-1/4 SD150-R100B99-1/4	69014192773 69014191695 69014191696

STANDARD PACKAGE = 1 MOUNTED POINT, HAND HONE, OR WHEEL
CONTINUED

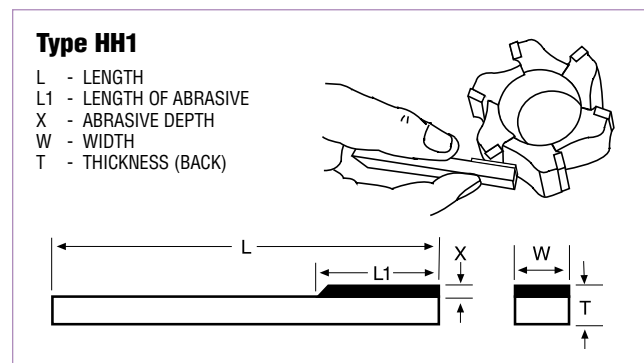

SIZE D X T X H	SPECIFICATION	PART NO.
TYPE 1A1 STRAIGHT – DIAMOND (CONT'D)		
6 x 1/2 x 1-1/4	ASD120-R75B99-1/4	69014192777
	ASD150-R75B99-1/4	69014191698
	ASD220-R75B99-1/4	69014192779
	ASD320-R75B99-1/4	69014192780
	SD120-R100B99-1/4	66260273557
7 x 1/4 x 1-1/4	SD150-R100B99-1/4	66260273561
	SD180-R100B99-1/4	69014191700
	ASD150-R75B99-1/4	69014191701
	SD100S-R100B99-1/4	69014192210
	SD120-R100B99-1/4	66260273566
7 x 3/8 x 1-1/4	SD150-R100B99-1/4	69014191703
	SD180-R100B99-1/4	69014191704
	SD220-R100B99-1/4	69014191705
	ASD150-R75B99-1/4	69014191848
	SD120-R100B99-1/4	69014191849
7 x 1/2 x 1-1/4	SD220-R100B99-1/4	69014191852
	ASD100-R75B99-1/4	69014192211
	ASD150-R75B99-1/4	69014191853
	ASD180-R75B99-1/4	69014192212
8 x 1/2 x 1-1/4	SD120-R100B99-1/4	69014191854
	SD150-R100B99-1/4	69014191855
	SD180-R100B99-1/4	69014191856
	SD220-R100B99-1/4	69014191857
8 x 1/2 x 1-1/4	SD150-R100B99-1/4	66260273574
10 x 1/2 x 3	ASD120-R75B99-1/4	69014192305
	ASD180-R100B99-1/4	69014192306
12 x 1/2 x 3	ASD150-R75B99-1/4	69014192310
12 x 1/2 x 5	ASD150-R75B99-1/4	69014192311
12 x 1 x 3	ASD120-R75B99-1/4	69014192312
12 x 1 x 5	ASD120-R75B99-1/4	69014192313
14 x 1/2 x 5	ASD150-R75B99-1/4	69014192314
14 x 1 x 5	ASD120-R75B99-1/4	69014192316
20 x 1 x 12	ASD120-R75B99-1/4	69014192325

TYPE 1A1 STRAIGHT – cBN

6 x 1/8 x 1-1/4	CB120-TB99-1/4	66260273601
6 x 1/4 x 1-1/4	CB120-TB99-1/4	66260273605
6 x 1/2 x 1-1/4	CB120-TB99-1/4	66260273607
7 x 1/4 x 1-1/4	CB120-TB99-1/4	69014192021
7 x 1/2 x 1-1/4	CB120-TB99-1/4	66260273567
12 x 1/2 x 5	CB150-TB99-1/4	66260273560
12 x 1 x 5	CB150-TB99-1/4	66260273562

STANDARD PACKAGE = 1 WHEEL

TECHtip

CYLINDRICAL GRINDING APPLICATIONS – 1A1 WHEELS:

- Includes all outside grinding of round parts, even though the finished product is not always a true cylinder.
- Infeed at both ends of the traverse to keep wheel face flat.
- Use work supports to prevent deflection.
- Rough grinding traverse speed should be 1/2 to 2/3 of the thickness of the wheel per work revolution.
- Finishing grinding traverse speed should be 1/2" or less per work revolution.

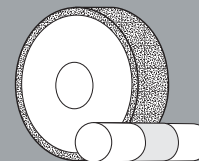

! It is the user's responsibility to refer to and comply with ANSI B7.1

DIAMOND GRINDS:

- Cemented carbide
- Glass
- Ceramics
- Fiberglass
- Plastics
- Stone
- Abrasives
- Electronic components and materials

cBN GRINDS:

- High-speed tool steels
- Die steels
- Hardened carbon steels
- Alloy steels
- Aerospace alloys
- Hard stainless steel
- Abrasion-resistant ferrous materials

Can't Find Your Specification Here?

- Refer to the brief descriptions of our toolroom, B99 Express, CNC, and saw grinding lines (following this section)
- See the "Diamond and cBN" product groups on www.nortonindustrial.com or contact your Norton representative for a complete listing of these stock and made-to-order superabrasive products.

Type HH2

- L - LENGTH
- L1 - LENGTH OF ABRASIVE
- X - ABRASIVE DEPTH
- W - WIDTH
- T - THICKNESS (BACK)

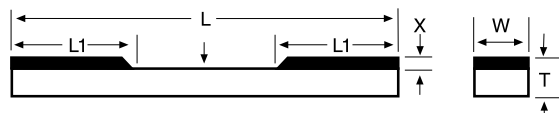
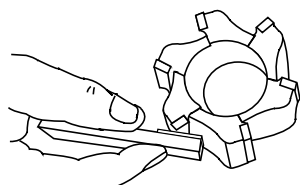

Type 1A1

- D - DIAMETER
- X - ABRASIVE DEPTH
- H - HOLE
- T - THICKNESS

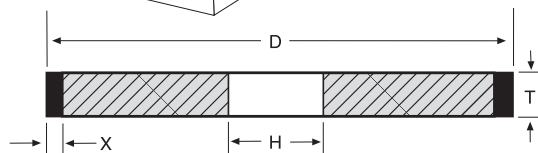
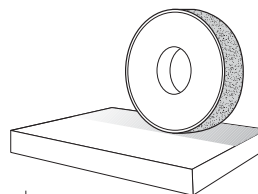

SIZE D X T X H	SPECIFICATION	PART NO.
TYPE 1A1R CUT-OFF – DIAMOND		
3 x .020 x 1/2 (ME104177)	M4D150-N50M99-1/8	69014192060
4 x .012 x 1/2 (ME104180)	M4D180-N75M99-1/8 M4D220-N75M99-1/8	69014192063 69014192064
4 x .020 x 1/2 (ME104180)	M4D220-N100M99-1/8	69014192067
4 x .030 x 1/2 (ME104180)	M4D150-N75M99-1/8	69014192068
4 x 1/32 x 3/4 (ME43570)	SD100S-R100B99-1/4 SD120-R100B99-1/4	69014192151 69014191706
4 x 1/32 x 1-1/4 (ME43570)	SD100S-R100B99-1/4	69014192152
5 x .015 x 1/2 (ME104180)	M4D150-N100M99-1/8 M4D220-N100M99-1/8	69014192069 69014192070
6 x .017 x 1-1/4 (ME104180)	M4D150-N100M99-1/8 M4D220-N100M99-1/8	69014192082 69014192083
6 x .025 x 1-1/4 (ME104180)	M4D150-N100M99-1/8	69014192086
6 x .035 x 5/8 (ME104177)	M4D100-N75M99-1/8	69014192088
6 x .035 x 1-1/4 (ME43572)	ASD120-R75B99-1/4 SD100-R75B99-1/4 ASD100S-R100B99-1/4 ASD120-R100B99-1/4 SD100-R100B99-1/4 SD100S-R100B99-1/4 SD220-R100B99-1/4	69014191707 69014192155 69014192158 69014192159 69014191858 69014192156 69014192157
6 x .035 x 1-1/4 (ME73316)	ASD100S-R100B99-9/32 ASD120-R100B99-9/32 SD100-R100B99-9/32 SD120-R100B99-9/32 SD150-R100B99-9/32	69014192164 69014192165 69014192161 69014192162 69014192163
6 x .045 x 1-1/4 (ME83991)	SD100-R50B99-1/8	69014192166
6 x .055 x 1-1/4 (ME104177)	M4D100-N75M99-1/8	69014192099
7 x .035 x 1-1/4 (ME82347)	ASD100-R100B99-1/4	66260238686
7 x .040 x 1-1/4 (ME104177)	M4D120-N75M99-1/8	69014192105
7 x .055 x 1-1/4 (ME104177)	M4D120-N100M99-1/8	69014192108
8 x .030 x 1-1/4 (ME104180)	M4D180-N75M99-1/8	69014192110
8 x .045 x 5/8 (ME43569)	SD120-R100B99-1/4	69014192167
8 x .045 x 1 (ME43569)	SD120-R100B99-1/4	69014192168
8 x .045 x 1-1/4 (ME43569)	SD120-R100B99-1/4	69014192169
8 x .050 x 1-1/4 (ME104180)	M4D180-N75M99-1/8	69014192114
10 x .050 x 1-1/4 (ME 43565)	ASD120-R100B99-1/4 CD100-R100B99-1/4 SD120-R100B99-1/4	66260230236 69014192815 69014192170
10 x .050 x 3 (ME 43565)	ASD100S-R75B99-1/4	69014192172
12 x .070 x 3/4 (ME 43567)	SD150-R100B99-1/4	69014192173
14 x .070 x 3/4 (ME 106589)	SD120-R100B99-1/4	66260259011
TYPE 1A1R CUT-OFF – cBN		
6 x .035 x 1-1/4 (ME43572)	CB100-WB99-1/4	69014192160

SIZE D X T X H	SPECIFICATION	PART NO.
TYPE 1V1P FLUTING – DIAMOND		
6 x 3/32 x 1-1/4 Face Bevel 1 Side 20 Deg Copper Core (ME89562)	ASD320B-R125B99-1/4 ASDC320C-R100B99-1/4	69014192302 69014192761

STANDARD PACKAGE = 1 WHEEL

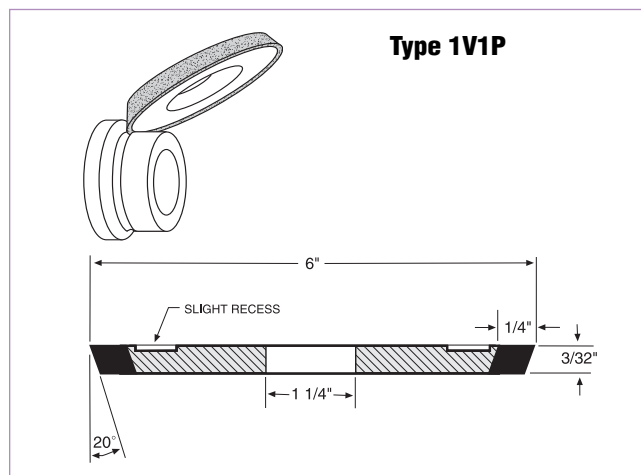
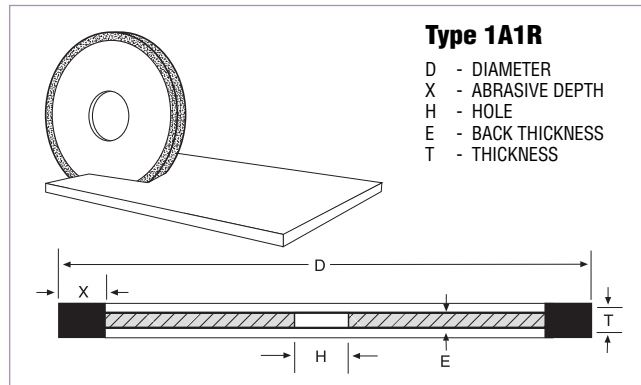

TECHtip

CUT-OFF APPLICATIONS – 1A1R WHEELS:

- Use the largest diameter flanges possible
- Use flanges of equal diameter
- Use the thickest wheel possible for increased stiffness and straightness of cut

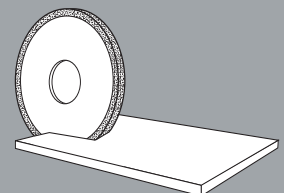

cBN wheels are used on hardened steels.

Diamond wheel are used to cut or slot carbide, glass or ceramic parts.



It is the user's responsibility to refer to and comply with ANSI B7.1

SIZE D X T X H	SPECIFICATION	PART NO.
TYPE 4A2P DISH – DIAMOND		
6 x 3/8 x 1-1/4 Rim Width 1/4" (ME88369)	ASD120-R75B99-1/16	69014192280
TYPE 6A2C STRAIGHT CUP – DIAMOND		
6 x 7/16 x 1-1/4 Rim Width 1" (0640185M)	D120/140-H-MSL	66260269172
6 x 3/4 x 1-1/4 Rim Width 3/4" (ME27853)	SD220-R50B99-1/16 ASD120-R75B99-1/16 ASD120-R75B99-1/8 SD150-P50V99-1/16 SD220-P50V99-1/16	69014191665 69014191860 69014192786 69014192217 69014191623
6 x 3/4 x 1-1/4 Rim Width 1/2" (ME30621)	ASD120-R75B99-1/8	66260273565

STANDARD PACKAGE = 1 WHEEL

SIZE D X T X H	SPECIFICATION	PART NO.
TYPE 6A2H STRAIGHT CUP – DIAMOND		
5 x 1 x 1-1/4 Rim Width 1-1/16" (ME27084)	SD320-R50B99-1/16	69014192221
TYPE 11A2 FLARING CUP – DIAMOND		
6 x 1-1/2 x 1-1/4 Rim Width 1/4" (ME128467)	ASD150-R100B99-1/4	69014192799

STANDARD PACKAGE = 1 WHEEL

Refer to “Brake Controlled Truing Devices” and “Dressing Sticks” sections for truing and dressing products.

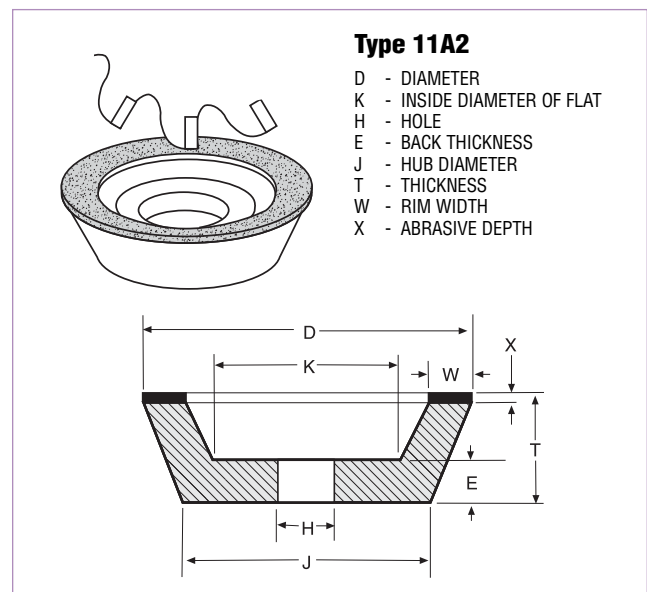
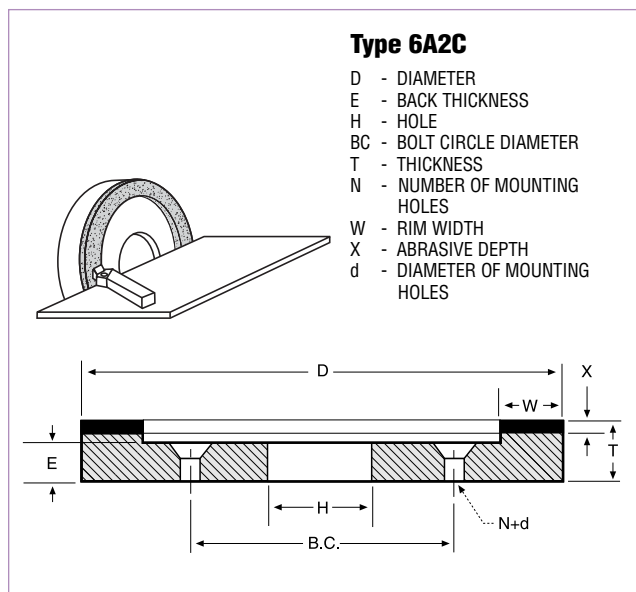
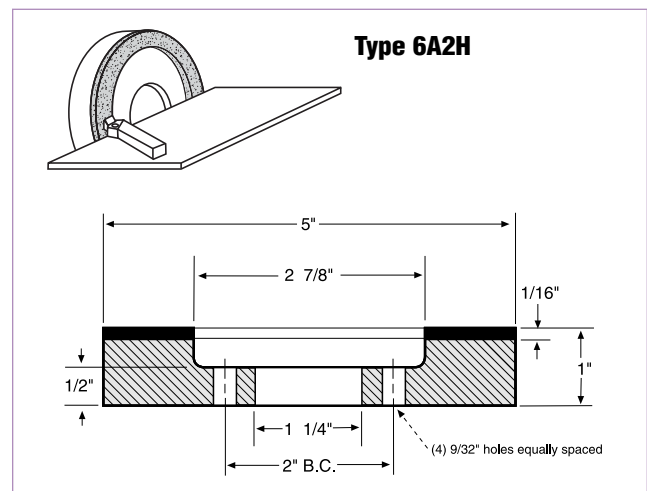
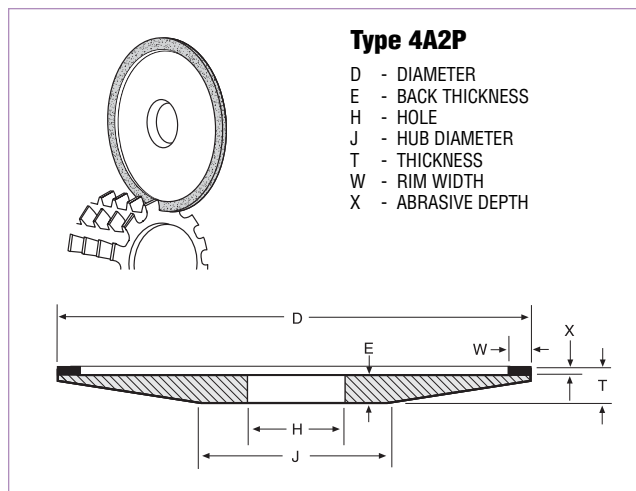

ASD DIAMOND / B105 RESIN BOND WHEELS
BEST CHOICE FOR DRY GRINDING CARBIDE TOOLS

FEATURES

- Premium quality diamond
- Advanced, heat-reducing bond
- Self-lubricating bond
- Unique self-dressing core

BENEFITS

- Produces keen cutting tools that hold their shape, are easier to sharpen, and require fewer reconditionings
- Minimizes heat generation and thermal damage to tool
- Increases tool life and productivity
- Lasts more than 2X as long as standard diamond wheels
- Lowest total wheel costs; highest productivity
- No steel or braze loading
- Uses less power
- Eliminates wheel core damage
- Eliminates downtime to dress core

SIZE D X T X H	SPECIFICATION	PART NO.
TYPE 11V9 FLARING CUP – DIAMOND		
3-3/4 x 1-1/2 x 1-1/4 Insert Length 3/8" (ME92192)	ASD100S-R75B105-1/16	69014191904
	ASD120-R75B105-1/16	69014191905
	ASD150-R75B105-1/16	69014191906
	ASD100S-R75B105-1/8	69014191908
	ASD120-R75B105-1/8	69014191909
5 x 1-3/4 x 1-1/4 Insert Length 7/16" (ME98298)	ASD150-R75B105-1/8	69014191910
	ASD120-R75B105-1/16	69014191913
	ASD150-R75B105-1/16	69014191914
	ASD100S-R75B105-1/8	69014191916
	ASD120-R75B105-1/8	69014191917
	ASD150-R75B105-1/8	69014191918

STANDARD PACKAGE = 1 WHEEL

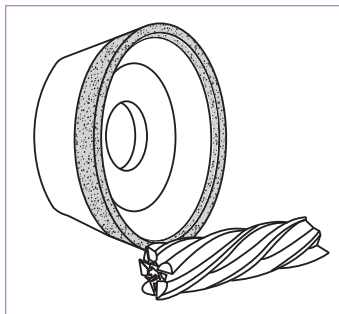

Refer to “**Brake Controlled Truing Devices**”
and “**Dressing Sticks**” sections for truing and
dressing products.

SIZE D X T X H	SPECIFICATION	PART NO.
TYPE 11V9 FLARING CUP – DIAMOND		
3 x 1-1/4 x 3/4 Insert Length 3/8" (ME93912)	ASD120-R75B99-1/16	69014192291
	ASD150-R75B99-1/16	69014192292
	SD150-R100B99-1/16	69014192293
3-3/4 x 1-1/2 x 3/4 Insert Length 3/8" (M92192)	ASD120-R75B99-1/16	69014192022
	ASD150C-R50B99-1/8	69014190751
5 x 1-3/4 x 1-1/4 Insert Length 7/16" (ME98298)	ASD120-R75B99-1/16	69014191660
	ASD150-R75B99-1/16	69014191725
	ASD180-R75B99-1/16	69014191658
	ASD220-R75B99-1/16	69014192363
	ASD100S-R75B99-1/8	69014191653
	ASD120-R75B99-1/8	69014191652
	ASD150-R75B99-1/8	69014191651
	ASD180-R75B99-1/8	69014191650
	SD120-R100B99-1/16	69014191657
	SD150-R100B99-1/16	69014191656
	SD220-R100B99-1/16	69014191654
	SD320-R100B99-1/16	69014192814
	SD100S-R100B99-1/8	69014192427
	SD120-R100B99-1/8	69014191649
	SD150-R100B99-1/8	69014191648
	SD180-R100B99-1/8	69014191647
	SD220-R100B99-1/8	69014191646
5 x 1-3/4 x 1-1/4 Insert Length 7/16" (ME98298)	ASD100S-R75B99-1/16	69014191645
	ASD120-R75B99-1/16	69014191644
	ASD150-R75B99-1/16	69014191643
	ASD100S-R75B99-1/8	69014191637
	ASD120-R75B99-1/8	69014191636
	ASD150-R75B99-1/8	69014191635
	ASD180-R75B99-1/8	69014191634
	ASD320-R75B99-1/8	69014192810
	SD120-R100B99-1/16	69014191641
	SD150-R100B99-1/16	69014191640
	SD180-R100B99-1/16	69014191639
SD220-R100B99-1/16	69014191638	
SD150-R100B99-1/8	69014191632	
SD180-R100B99-1/8	69014191631	

STANDARD PACKAGE = 1 WHEEL

NORTON AZTEC CBN WHEELS
BEST CHOICE FOR DRY TOOL RESHARPENING

FEATURES

- Consistent, high quality cBN (cubic Boron Nitride) abrasive
- Advanced heat-reducing bond conducts heat away from the workpiece

BENEFITS

- 85% longer life than standard cBN wheels
- Eliminates heat build-up and damage
- Extends wheel life
- Freer cutting action
- Maintains cutting tool steel integrity
- Extends cutting tool life

Aztec III

- Lubricating bond
- Eliminates steel and braze loading
- Reduces drag
- Allows greater infeeds

Aztec .007

- Allows increased infeed (start at .007)
- High stock removal rate
- Heaviest cuts with less wheel wear
- Lower grinding forces
- Elimination of chatter

SIZE D X T X H	SPECIFICATION	PART NO.
TYPE 11V9 FLARING CUP – cBN		
3-3/4 x 1-1/2 x 1-1/4 Insert Length 3/8" (ME92192)	AZTEC .007-100-1/16	69014195683
	AZTEC .007-150-1/16	69014195679
	AZTEC III 100T-1/16	69014191832
	AZTEC III 120T-1/16	69014191833
	AZTEC III 150T-1/16	69014191834
	AZTEC .007-150-1/8	69014195680
	AZTEC III 100T-1/8	69014191838
	AZTEC III 120T-1/8	69014191839
	AZTEC III 150T-1/8	69014191840
	AZTEC III 100W-1/16	69014191835
AZTEC III 150W-1/16	69014191837	
5 x 1-3/4 x 1-1/4 Insert Length 7/16" (ME98298)	AZTEC .007-100-1/16	69014195685
	AZTEC III 100T-1/16	69014191841
	AZTEC III 120T-1/16	69014191842
	AZTEC III 150T-1/16	69014191843
	AZTEC .007-100-1/8	69014195686
	AZTEC .007-150-1/8	69014195682
AZTEC III 100T-1/8	69014191844	

STANDARD PACKAGE = 1 WHEEL

SIZE D X T X H	SPECIFICATION	PART NO.
TYPE 11V9 FLARING CUP – cBN		
3-3/4 x 1-1/2 x 1-1/4 Insert Length 3/8" (ME92192)	CB100-TB99-1/16	69014191719
	CB100-TB99-1/8	69014191722
	CB120-TB99-1/8	69014191723
	CB150-TB99-1/8	69014191724
	CB120-WB99-1/16	69014191720
5 x 1-3/4 x 1-1/4 Insert Length 7/16" (ME98298)	CB150-WB99-1/16	69014191721
	CB120-TB99-1/8	69014191715
	CB150-TB99-1/8	69014191716

STANDARD PACKAGE – 1 WHEEL

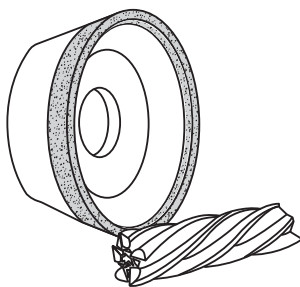

Type 11V9

- D - DIAMETER
- K - INSIDE DIAMETER OF FLAT
- H - HOLE
- E - BACK THICKNESS
- T - THICKNESS
- J - HUB DIAMETER
- U - INSERT LENGTH
- X - ABRASIVE DEPTH
- S - FACE ANGLE

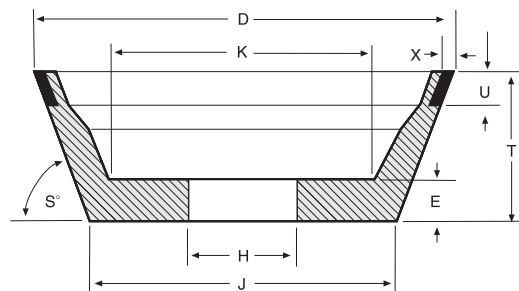

SIZE D X T X H	SPECIFICATION	PART NO.
TYPE 12A2 DISH – DIAMOND		
4 x 1/2 x 1-1/4 Rim Width 1/4" (ME40745)	SD180-R75B99-1/8	69014192223
6 x 1 x 1-1/4 Rim Width 3/16" (ME27758)	ASD120-R75B99-1/8 ASD180-R75B99-1/8	69014191630 69014192226
TYPE 12A2 DISH – cBN		
6 x 1 x 1-1/4 Rim Width 3/16" (ME27758)	CB120-TB99-1/16	69014192227
TYPE 12V9 DISH – DIAMOND		
3 x 7/16 x 3/4 Insert Length 7/16" (ME41755)	SD150-R100B99-1/16	69014192228
4 x 1/2 x 1-1/4 Insert Length 1/4" (ME58734)	SD180-R100B99-1/8	69014191629
6 x 3/4 x 1-1/4 Insert Length 3/8" (ME48666)	ASD150-R75B99-1/16	69014191628
TYPE 12V9 DISH – cBN		
4 x 1/2 x 1-1/4 Insert Length 1/4" (ME58734)	CB120-TB99-1/8	69014192229
6 x 3/4 x 1-1/4 Insert Length 3/8" (ME48666)	CB120-TB99-1/8 CB150-TB99-1/8	69014192020 69014192784
TYPE 15V9 DISH – DIAMOND		
6 x 3/4 x 1-1/4 Insert Length 3/8" (ME40633)	SD150-R100B99-1/16	69014192230

STANDARD PACKAGE = 1 WHEEL

Norton offers a comprehensive stock product selection to service most of your needs – with the fastest delivery and lowest prices.

- Review this stock section first. If you can not find the specification you need:
- Then refer to the brief descriptions of our Norton/Winter toolroom, B99 Express, CNC, and saw grinding lines, (following this section)
- See the “Diamond and cBN” product groups on www.nortonindustrial.com or contact your Norton representative for a complete listing of these stock and made-to-order superabrasive products.

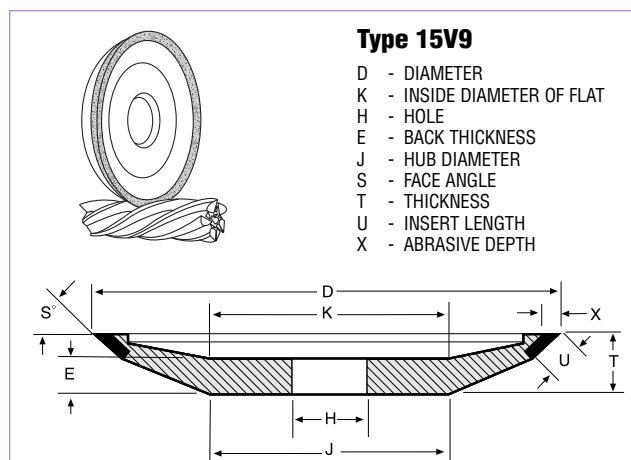
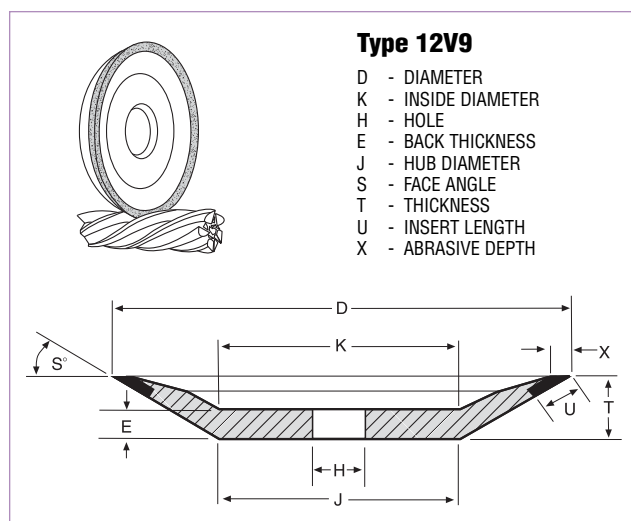
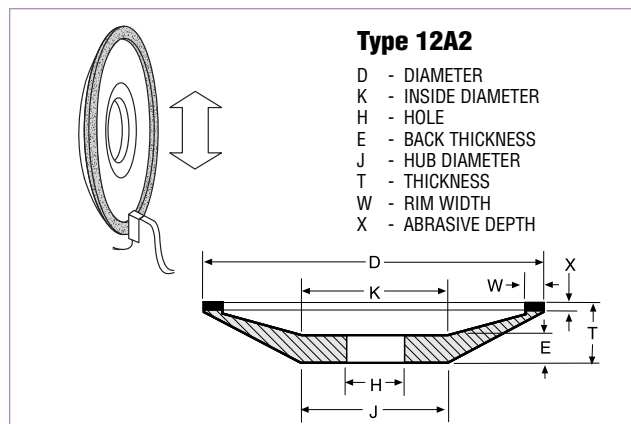

Norton B99 Express Service

The Norton B99 Express service is designed to offer you up to 65,000 made-to-order choices of resin bond Diamond and cBN wheels. Almost all popular sizes are offered.

12" and less diameter B99 Express wheels will ship in two weeks or less from the date the order is received by Norton. 14" and larger wheels are available at standard lead-times.

See the B99 Express service summary in this catalog and go to our www.nortonindustrial.com website for complete details.



CATEGORY DEFINITION

Norton/Winter toolroom grinding wheels combine American application and production expertise, and German technology to provide the most accurate and cost-effective grinding solutions. Their precise geometry and superior consistency translate to lower manufacturing and regrinding costs and improved tool quality.

- APPLICATIONS:
- Tool making and regrinding – dry and wet
 - Aerospace
 - Bearings
 - Powertrain
 - Saw
 - Thread-forming



NORTON/WINTER STOCK AND NON-STOCK TOOLROOM PRODUCTS

FEATURES

- Superior, synthetic superabrasives
- Specialty shapes (see Type 222, 700, 704 and 707)
 - 222 for facing and use on some topping grinders
 - 700, 704 and 707 for gauging and use on some topping grinders

BENEFITS

- Reduced cycle times; less dressing; longer wheel life
- Consistent wheel-to-wheel performance
- Grind with less heat and pressure
- Allow more efficient grinding where complex programs and geometries are involved

Diamond Pre-engineered Bonds

- | | |
|---|---|
| <ul style="list-style-type: none"> • K+777 and K+888 | <ul style="list-style-type: none"> • Precision dry grinding at high speeds |
| <ul style="list-style-type: none"> • K+920 | <ul style="list-style-type: none"> • Engineered for dry and wet grinding with narrow-rim straight wheels • Wear-resistant bond for wet cup grinding |
| <ul style="list-style-type: none"> • K+4821 | <ul style="list-style-type: none"> • Premium, sharp cutting action; extended wheel life when grinding carbide |

cBN Pre-engineered Bonds

- | | |
|--|---|
| <ul style="list-style-type: none"> • KSS10 | <ul style="list-style-type: none"> • Ideal for dry toolroom cup wheel grinding |
| <ul style="list-style-type: none"> • KSS920 | <ul style="list-style-type: none"> • Engineered for dry and wet grinding with narrow-rim straight wheels • Wear-resistant bond for wet cup grinding |

This is a brief description of our comprehensive Norton/Winter Toolroom stock and made-to-order line. See our complete Norton/Winter Toolroom product listing in the “Diamond and cBN” product group on www.nortonindustrial.com or contact your Norton representative for more details.

TECHtip

DIAMOND GRINDS:

In general, diamond is used to grind non-ferrous materials, because it reacts with iron.

- Cemented carbide
- Glass
- Ceramics
- Fiberglass
- Plastics
- Stone
- Abrasives
- Electronic components and materials

cBN GRINDS:

cBN is used to grind ferrous materials.

- High-speed tool steels
- Die steels
- Hardened carbon steels
- Alloy steels
- Aerospace alloys
- Hardened stainless steel
- Abrasion-resistant ferrous materials

 It is the user's responsibility to refer to and comply with ANSI B7.1



CATEGORY DEFINITION

65,000+ made-to-order resin products; 25 wheel shapes, with 2-week lead-times for 12" and less diameter wheels. 14" and larger wheels and 80 grit and coarser wheels are available with standard made-to-order lead-times. If you do not find the resin specification and/or shape you need in our stock offering, you will most likely find it in our B99 Express made-to-order offering.

APPLICATIONS:

Norton B99E Diamond Wheels

- Sharpening cemented carbide cutting tools
- Cutting-off carbide rod
- Grinding or cutting-off non-metallic materials such as ceramics or glass
- Surface grinding dies
- O.D. grinding spray coatings

Norton B99E cBN Wheels

- Sharpening high-speed (M2, D2, T15, etc.) steel cutting tools
- Surface and ID grinding hardened steel die components
- Precision grinding steel parts Rc 50 or harder

B99 EXPRESS MADE-TO-ORDER DIAMOND AND CBN RESIN BOND WHEELS

FEATURES

- Superior diamond and cBN abrasives in durable resin bond systems
- Thousands of abrasive, grit, grade, concentration, and bond combinations
- Made in our state-of-the-art, USA, ISO-certified facilities
- Priced as stock products
- NEW! Two-week (and less) lead-times

BENEFITS

- These quality wheels will get your job done
- There is a B99 Express wheel for almost every resin bond application
- Exceptional quality and performance
- Excellent performance/price ratio
- Minimal time from order to production floor



SEE OUR NEW 1-WEEK B99 EXPRESS LEAD TIMES!

NORTON B99 EXPRESS MADE-TO-ORDER RESIN BOND LEAD-TIMES

1-WEEK LEAD-TIME:

- All 1A1 aluminum core wheels with stock pre-forms
- All 1A1R wheels with diameter <14"
- All 11V9 wheels
- All 12V9 Resaloy core wheels
- All 15V9 Resaloy core wheels
- All composite core wheels, with thickness < 1/8"
 - 1A1, 1B1, 1E1, 1F1

2-WEEK LEAD-TIME:

- All other wheels with diameter <14"

3-WEEK LEAD-TIME:

- All wheels with diameter >= 14"
- All wheels with 80 grit and coarser

This is a brief description of our B99 Express made-to-order resin bond line. See the complete B99 Express availability in the "Diamond and cBN" product group on www.nortonindustrial.com or contact your Norton representative for more details.

HOW TO SELECT B99 EXPRESS MADE-TO-ORDER DIAMOND WHEELS

SELECT

WHEEL DIMENSIONS	D x T x H Select Diameter x Thickness x Hole from the availability tables on www.nortonindustrial.com . Use blueprint numbers where available.	Note: Standard made-to-order lead-times apply to 14" and larger wheels.
ABRASIVE	<p>ASD Armored diamond; most durable. Versatile: can be used wet or dry. ASD should be used when carbide and steel are ground in the same operation.</p> <p>SD Free cutting standard. Can be used wet or dry; should be used on low horsepower (3/4 hp or less) machines.</p>	Select the abrasive based on horsepower, grinding wet or dry, and contact with steel.
GRIT SIZE	<p>100 Roughing. The most common grit size for roughing operations.</p> <p>120 For roughing where 100 is too coarse. Also for cut-off applications.</p> <p>150 Medium stock removal plus good finish. For combined roughing and finishing applications.</p> <p>180 Medium stock removal plus good finish. To improve finish.</p> <p>220 Finishing</p> <p>320 Finishing</p> <p>400 Fine finishing</p>	Select the grit size based on finish and material removal rate required. Note: Standard made-to-order lead-times apply to 80 grit and coarser wheels.
GRADE	R Resin bond standard	The hardness of the wheel
CONCENTRATION	<p>50 Shape 2A2T only. For broad area of contact grinding.</p> <p>75 Norton standard. Freer cutting than 100 grit and the most economical for dry grinding with ASD diamond.</p> <p>100 Very durable. Recommended under flood coolant conditions. For use with 220 grit or finer, when durability is required. Also for cut-off applications.</p> <p>125 Improved form holding. Used with B99EF bond only for form holding in high-volume, high-pressure coolant applications. Used with ASD abrasive.</p>	Select the concentration based on grinding wet or dry, material removal rates, and form holding requirements.
BOND	<p>B99E Norton standard pre-engineered resin bond. Versatile enough to be used wet or dry on most tool making or resharpening applications as well as for grinding non-metallic materials such as ceramics or glass. Available in all shapes.</p> <p>B99EF Improved form holding. More durable than B99E. Improved heat dissipation in wet or dry applications. Available in wheel shapes 1V1, 1B1, 1E1, 1EE1, 1F1 and 1FF1.</p>	Select the bond based on the material being ground and grinding application.
ABRASIVE DEPTH	<p>1/16</p> <p>1/8</p> <p>1/4</p> <p>1/2 NEW!</p>	Usable abrasive

TECHtip

DIAMOND GRINDS:

In general, diamond is used to grind non-ferrous materials, because it reacts with iron.

- Cemented carbide
- Glass
- Ceramics
- Fiberglass
- Plastics
- Stone
- Abrasives
- Electronic components and materials

cBN GRINDS:

cBN is used to grind ferrous materials.

- High-speed tool steels
- Die steels
- Hardened carbon steels
- Alloy steels
- Aerospace alloys
- Hardened stainless steel
- Abrasion-resistant ferrous materials

Norton offers a comprehensive stock product selection to service most of your needs – with the fastest delivery and lowest prices.

- Review the previous Norton stock section first
- Then refer to the brief descriptions of our Norton/Winter toolroom, CNC and saw grinding lines

Can't find the specification in the above sections?

- Then refer to this B99 Express Made-to-Order Resin Product section.

If a product can not be found in the B99 Express offering:

- See the "Diamond and cBN" product group on www.nortonindustrial.com or contact your Norton representative for a complete listing of these stock and made-to-order superabrasive products.



It is the user's responsibility to refer to and comply with ANSI B7.1

HOW TO SELECT B99 EXPRESS MADE-TO-ORDER cBN WHEELS

SELECT

WHEEL DIMENSIONS	D x T x H Select Diameter x Thickness x Hole from the availability tables on www.nortonindustrial.com. Use blueprint numbers where available.	Note: Standard made-to-order lead-times apply to 14" and larger wheels.
ABRASIVE	CB Norton standard coated cBN (cubic Boron Nitride). Optimized for high performance in resin bond systems.	Select Norton cBN abrasive to grind hard tool steels such as A2, D2, T15, etc., and tough alloy steels.
GRIT SIZE	<p>100 Roughing. The most common grit size for roughing operations.</p> <p>120 For roughing where 100 is too coarse. Also for cut-off applications.</p> <p>150 Medium stock removal plus good finish. For combined roughing and finishing applications.</p> <p>180 Medium stock removal plus good finish. To improve finish.</p> <p>220 Finishing</p> <p>320 Finishing</p> <p>400 Fine finishing</p>	<p>Select the grit size based on finish and material removal rate required.</p> <p>Note: Standard made-to-order lead-times apply to 80 grit and coarser wheels.</p>
GRADE	<p>T Norton standard. Approximately 75 concentration, T is the first choice for lower horsepower equipment or wide area of contact between the wheel and the workpiece. Ideal for resharpening applications with 11V9, 12A2, 4A2P, and 15V9 wheel shapes when dry grinding.</p> <p>W Very Durable. Approximately 100 concentration, W is recommended for high volume coolant operations: flute grinding from solid, flute polishing, surface, and cylindrical grinding.</p> <p>Z Form holding. Approximately 125 concentration, Z grade is extremely durable and is recommended where long life or form holding is required in high-volume, high-pressure coolant applications. Used with B99EF bond only.</p>	The hardness of the wheel
BOND	<p>B99E Norton standard resin bond. Pre-engineered for optimal performance with cBN abrasive. Available in all shapes.</p> <p>B99EF Improved form holding. More durable than B99E. Improved heat dissipation in wet or dry applications. Available in wheel shapes 1V1, 1B1, 1E1, 1EE1, 1F1 and 1FF1.</p>	Select the bond depending on the type of grinding application.
ABRASIVE DEPTH	<p>1/16</p> <p>1/8</p> <p>1/4</p> <p>1/2 NEW!</p>	Usable abrasive



SEE OUR NEW 1-WEEK B99 EXPRESS LEAD TIMES!

NORTON B99 EXPRESS MADE-TO-ORDER RESIN BOND LEAD-TIMES

1 WEEK LEAD-TIME:

All 1A1 aluminum core wheels with stock pre-forms
 All 1A1R wheels with diameter <14"
 All 11V9 wheels
 All 12V9 Resaloy core wheels
 All 15V9 Resaloy core wheels
 All composite core wheels, with thickness < 1/8"
 • 1A1, 1B1, 1E1, 1F1

2 WEEK LEAD-TIME:

All other wheels with diameter <14"

3 WEEK LEAD-TIME:

All wheels with diameter >= 14"
 All wheels with 80 grit and coarser



CATEGORY DEFINITION

These superior, pre-engineered wheels have been specifically developed to meet the demanding needs of precision cutting tool manufactures as well as re-sharpeners. The use of the highest quality diamond and cBN abrasives matched to superior high temperature bond systems, guarantees high performing wheels. These wheels are manufactured under the strictest quality control protocols ensuring the same, consistent, high-performing product. Cutting tool manufactures who use these wheels report much improved dimensional accuracy and superior cutting edges.

This product offering provides wheel sizes for most CNC machines and wheels shapes to produce the required cutting tool geometries. If you do not find a wheel in this offering to suit your specific needs, a custom-made wheel can be provided.

- APPLICATIONS:
- CNC round tool grinding

NORTON POLYIMIDE CNC WHEELS

BEST CHOICE TO MAXIMIZE THE PERFORMANCE OF TODAY'S CNC MACHINES

FEATURES

Univel and G-Force premium products

- Polyimide bond systems with superior form-holding and lower-power requirements compared to premium competitive wheels

G-Force

- Unique bond technology
- Self-dressing
- The only product on the market that is truly rotary dress-able
- Leads the industry in depth of cut, traverse rates and form holding

BENEFITS

- Reduced frequency of dresses
- Decreased chances of burn and heat damage to the part

NORTON/WINTER CNC WHEELS

BETTER CHOICE FOR SHORT-RUN MANUFACTURING OPERATIONS WITH FREQUENT WHEEL PROFILE CHANGES

FEATURES

- A price competitive alternative to Univel and G-Force

BENEFITS

- The product of choice for short-run manufacturing jobs where frequent wheel profile changes are required, and premium wheels can not be cost-justified
- Can be reshaped for numerous short runs
- Great performance/price ratio

NORTON CNC WHEELS

GOOD CHOICE FOR RESHARPENING AND SHORT-RUN MANUFACTURING OPERATIONS

FEATURES

- Ideal for resharpening and short-run manufacturing operations
- Free-cutting phenolic specifications formulated for oil coolants
- Consistent wheel-to-wheel performance
- Precision tolerances

BENEFITS

- Competitively-priced while providing premium performance
- Grind with less heat and pressure – eliminating burning
- Reduced cycle times, less dressing = longer wheel life
- Repeatable part geometry

This is a brief description of our comprehensive Norton CNC stock and made-to-order line. See our complete CNC wheel product listing in the “Diamond and cBN” product group on www.nortonindustrial.com or contact your Norton representative for more details.



CATEGORY DEFINITION

Norton Saw Grinding Wheels

Norton/Winter abrasive engineers worked closely with the early saw grinding machine builders, jointly developing the wheel designs that have become the industry standard. We continue to provide excellent performing abrasive products to the forestry and saw markets, decreasing your manufacturing and regrinding costs.

- APPLICATIONS:
- Primary and secondary saw sharpening/grinding
 - Router bit and cutter grinding
 - Topping, facing, side grinding, and profiling

Norton/Winter Saw Grinding Wheels

NORTON/WINTER SAW GRINDING WHEELS – POWERED BY WINTER TECHNOLOGY

BEST CHOICE FOR AUTOMATIC SAW GRINDERS

FEATURES

- Superior, synthetic superabrasives
- Special phenolic bonds designed for automatic feeds: use with coolants
- Controlled, self-sharpening wheel wear
- Designed to run well immediately upon mounting
- Specialty shapes (see Type 222 and 700)
222 for facing and use on some topping grinders
700 for side grinding and use on some topping grinding

BENEFITS

- Reduced cycle times; less dressing; longer wheel life
- Result in wheels uniquely suited for automatic saw grinders
- Exceptional metal removal rates
- Eliminates the "break-in" period
- Allow more efficient grinding where complex programs and geometries are involved
- Precision tolerances for repeatable part geometry

Norton Silver Eagle Saw Grinding Wheels

With many of the most common sizes and grits in stock, the pre-engineered, comprehensive line of diamond and cBN Norton Silver Eagle saw grinding wheels meets the needs of the forestry and saw sharpening markets.



NORTON SILVER EAGLE DIAMOND AND CBN WHEELS

FEATURES

- Quality synthetic diamond and cBN abrasives
- A proven bond system developed specifically for automatic saw grinding in the primary and secondary saw market
- Unique wheel design
- Self-dressing core

BENEFITS

- Competitively-priced while providing solid performance
- Provides solid performance and an economical solution for all your saw manufacturing and regrinding needs
- Will sharpen any saw – fine or coarse pitch
- Wheel does not have to be removed from the machine to dress the core, giving more machine up time

This is a brief description of our comprehensive Norton Saw Grinding stock and made-to-order lines. See our complete Saw Grinding wheel product listing in the "Diamond and cBN" product group on www.nortonindustrial.com or contact your Norton representative for more details.

CATEGORY DEFINITION

Brake Controlled Truing Devices

Designed for truing diamond and cBN wheels rapidly, effectively, and with a minimum of superabrasive loss. Recommended for wheels up to 12" in diameter.

- APPLICATIONS:
- Truing 1A1, 11V9, 11A2, 6A2 and 12A2 wheels:
 - Straight wheels, used on chip breaker, tool and cutter, surface, and cylindrical grinding machines
 - Cup wheels, used on vertical spindle surface grinders
 - Cut-off wheels



Stock 4597 Brake Controlled Truing Device

The 4597 model is engineered for heavier and more frequent truing applications. The adjustable speeds allow for varying conditions (between 1050 and 1500 SFPM). It comes complete with a reusable case, "True to Form, Dress to Cut" training video, two 3" 38A60-M8VBE vitrified wheels, Truing Device Tips book, and a dressing stick. It can be rebuilt using the 4597RK Rebuild Kit.

Worn #4597 brake controlled truing devices (UPC 66260195350) in need of reconditioning (beyond new shoes and springs) may be returned to be rebuilt. Contact Customer Service for return instructions and quote.

Stock 3597 Brake Controlled Truing Device

The 3597 model is ideal for light duty use. The pre-set brake speed requires no adjusting. This model includes one 3" 38A60-M8VBE vitrified wheel and can be rebuilt using the 3597RK Rebuild Kit.

Stock 4597RK and 3597RK Rebuild Kits

You can rebuild your truing device with these kits, consisting of three brake shoes, three springs, and three screws.

ITEM	BETTER		GOOD	
	PRODUCT NO.	PART NO.	PRODUCT NO.	PART NO.
4597 BRAKE CONTROLLED TRUING DEVICE	4597	66260195350		
4597RK REBUILD KIT	4597RK	66260195351		
3597 BRAKE CONTROLLED TRUING DEVICE			3597	66260135578
3597RK REBUILD KIT			3597RK	66260135595
REPLACEMENT WHEELS 3 X 1 X 1/2			38A60-MVBE 38A80-MVBE 37C60-MVK 37C80-HVK 37C80-MVK 37C100-HVK 37C100-MVK	66243529145 66243529146 66243529166 66243529170 66243529171 66243529172 66243529070

SPECcheck

TRUING DIAMOND AND CBN WHEELS

SUPERABRASIVE WHEEL TRUING WHEEL SPECIFICATION

RESIN AND VITRIFIED BOND

80, 100 and 120 Grit	38A60-MVBE, 37C60-MVK
150, 180 and 220 Grit	38A80-MVBE, 37C80-MVK
320 and finer Grits	37C100-HVK

METAL BOND

80, 100 and 120 Grit	38A60-MVBE
150, 180 and 220 Grit	38A80-MVBE
240 and finer Grits	37C80-HVK

TECHtip

- Prior to truing the wheel, run a wax crayon over the wheel face. Important: do NOT use any liquid-based ink on superabrasive wheels.
- Any crayon left on the wheel face after truing will reveal untrued areas.
- Indicate the superabrasive wheel runoff before starting... usually within .001" to .002", to minimize wheel loss.
- Mount the device spindle parallel to the wheel spindle to ensure proper straight face truing.
- For cup-shaped wheels, the device spindle will be mounted perpendicular to the wheel spindle.
- Always use the brake controlled truing device dry.
- Bring the diamond/cBN wheel and the truing wheel together until they almost touch.
- Start the diamond/cBN wheel to normal speed; spin the truing wheel in the same direction at point of contact.
- Bring the two wheels together until they touch.
- Make sure the truing wheel is spinning at time of contact.
- Traverse the wheel back and forth at 30 to 60 inches/minute.
- Downfeed .0005" to .001" at the end of each traverse.
- At the end of truing, the diamond/cBN wheel should be smooth and in truth.
- Apply a dressing stick to sharpen the wheel.



It is the user's responsibility to refer to and comply with ANSI B7.1

Diamond and cBN Wheel Mounting, Truing and Dressing Guide

To achieve the best results using Norton diamond and cBN products, the following steps for mounting, truing and dressing should be practiced:

MOUNTING – Putting Wheel on Machine Spindle

- Examine wheel flanges and spindle carefully.
- Be sure flanges' surfaces are clean and free of damage.
- Ensure that the mounting flanges are flat and of equal diameter, especially on wheels with rigid centers, such as vitrified bond wheels.
- Paper or plastic blotters should only be used when mounting superabrasive wheels with vitrified cores. Using paper or plastic blotters on any other core material may result in the wheel loosening during grinding.
- Inspect machine spindle for excessive runout.
 - TIR (Total Indicated Runout) should be no greater than 0.0002".
- Mount wheel between hand-tightened flanges.
- Using a dial indicator, tap the wheel lightly with a rubber or wooden block to minimize runout to less than .0010".
- Tighten flange securely and recheck with indicator.
- Allow a newly mounted wheel to operate for one full minute before grinding.
- The use of one permanent mounting for the life of the wheel is recommended whenever possible:
 - If the grinding machine has a tapered spindle, mount each straight, flaring cup or dish wheel on a separate collet or adapter.
 - When changing wheels the entire unit is removed, keeping the wheel in running truth.
 - When needed again, the entire unit can be placed directly on the spindle or arbor, thereby eliminating the time and abrasive lost in retruing.

TRUING – Making Wheel Round and Concentric with the Spindle Axis

- Prior to truing the wheel, run a wax crayon over the wheel face. Important: do not use any liquid-based ink on superabrasive wheels.
- Any crayon left on the wheel face after truing will reveal untrued areas.
- Indicate the superabrasive wheel runout before starting... usually within .001" to .002", to minimize wheel loss.
- Norton brake controlled truing devices are most commonly used to true Diamond and cBN straight, cup and cylinder wheels.
 - Mount the device spindle parallel to the wheel spindle to ensure proper straight face truing.
 - For cup wheels, the device spindle will be mounted perpendicular to the wheel spindle.
 - Always use brake controlled truing device dry.
 - Bring the diamond/cBN wheel and the truing wheel together until they almost touch.
- Start the diamond/cBN wheel to normal speed; start the truing wheel in the same direction.
- Bring the two wheels together until they touch.
- Make sure the truing wheel is spinning at time of contact.
- Traverse the wheel back and forth at 30 to 60 inches per minute.
- Downfeed .0005" to .001" at the end of each traverse.
- At the end of truing, the diamond/cBN wheel should be smooth and in truth.
- Apply a dressing stick to sharpen the truing wheel.

DRESSING – Opening the Face of a Trued Wheel

- Dressing the abrasive – a cleaning/sharpening process to expose sharp, free-cutting grit:
 - For resinoid and vitrified bond wheels, the dressing stick should be one or two grit sizes finer than the abrasive in the diamond/cBN wheel – in a soft grade such as H or I.
 - For metal bond wheels, choose a stick with the same grit or one grit coarser than the wheel abrasive – in a medium grade (K – N).
 - See the "Dressing Stick" section for recommendations.
- Dressing the core – The core material (the part of the wheel that holds and supports the abrasive-bearing section) should never contact the work piece during grinding; rubbing will generate excessive heat. As the abrasive section of a cup wheel wears, the core material might become exposed, necessitating dressing.
 - Use a single-point carbide or steel tool to dress an exposed resaloy core.
 - Clamp the tool in a vise.
 - Direct the cutting edge accurately to leave a 1/16" of abrasive section exposed.

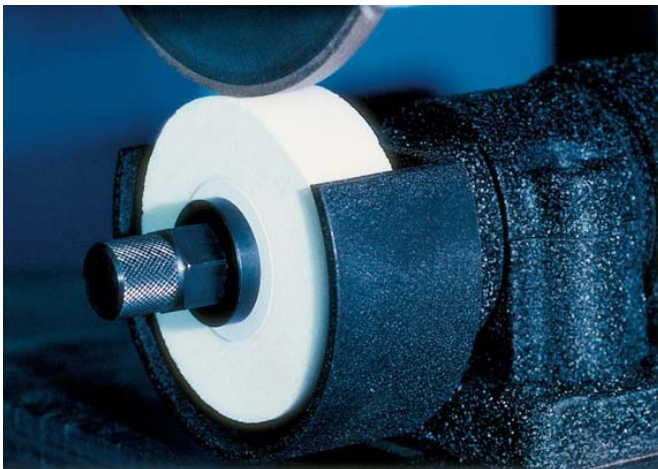

Properly Dressed Wheel Face

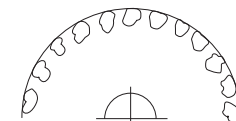

AFTER TRUING
THE WHEEL FACE IS SMOOTH
AND CLOSED

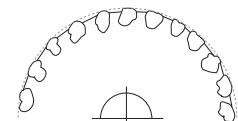

AFTER DRESSING
THE WHEEL FACE IS OPEN WITH THE
GRITS EXPOSED, READY FOR
EFFICIENT GRINDING ACTION

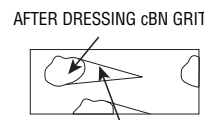

AFTER DRESSING cBN GRIT
TAIL
(BOND SUPPORTING GRIT)

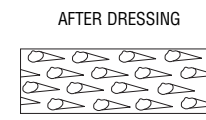

AFTER DRESSING
PATH CONNECTING THE TAILS FOR
COOLANT AND CHIP FLOW

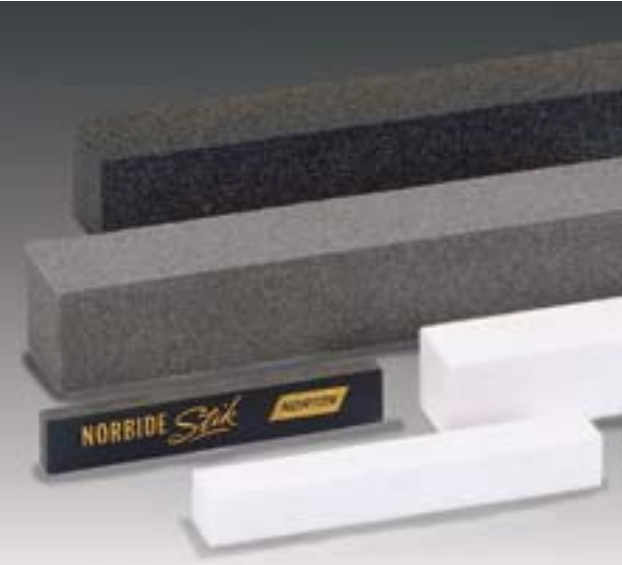

CATEGORY DEFINITION

Regular use of properly selected dressing sticks will help you achieve maximum performance from your grinding wheels

APPLICATIONS:	Truing, cleaning, and dressing diamond, cBN, and conventional abrasive wheels
SIZE RANGE:	Thickness/Width/Diameter: 1/4" – 1" Length: 3" – 8"
GRIT RANGE:	16 – 400
ABRASIVE GRAIN:	Aluminum Oxide, Boron Nitride, Silicon Carbide
SHAPE:	Square and round

GRINDING WHEEL-TO-PRODUCT RECOMMENDATION GUIDE

Selecting the appropriate dressing stick for each application depends on the wheel size, type, speed, specification and grit size, as well as the workpiece material. Initial starting specifications are listed below. We recommend testing several sticks to find the best one for your application.

VITRIFIED DRESSING STICKS		
Product	Specification	
Superabrasive Wheels - Resin and Vitrified Bond		
- 80, 100 and 120 Grits	Dressing Stick	38A150-HVBE
- 150, 180 and 220 Grits	Dressing Stick	38A220-HVBE
- 320 and finer grits	Superfine Stick	NMVC400-J5VCA
Superabrasive Wheels - Metal Bond		
- 80, 100 and 120 Grits	Dressing Stick	37C80-NV
- 150, 180 and 220 Grits	Dressing Stick	37C150-KV
- 240 and finer Grits	Dressing Stick	37C220-KV
Conventional Vitrified Wheels - Vitrified Bond		
- 46 grit and finer and M grade and softer	High Performance Dressing Stick	Norbide
	Conventional Dressing Stick	37C24-SVK



Norbide High Performance Sticks

For offhand truing and dressing of medium grit, soft- and medium-grade vitrified grinding wheels. Norbide and Boron Carbide are the hardest sticks you can buy. Made from boron nitride, they are well suited for dressing tool and cutter wheels 10" and smaller, especially cup and saucer shapes.

AVAILABILITY

SIZE (T X W X L*)	STD. PKG.	SPEC.	TIER: BEST		BETTER	
			PART NO.	SPEC.	PART NO.	
HIGH PERFORMANCE LONG LIFE STICKS						
1/4 x 1/2 x 3	5			Boron Carbide		61463629472
1/4 x 1/2 x 3	5	Norbide	61463610148			

* THICKNESS X WIDTH X LENGTH

TECHtip

DRESSING DIAMOND AND CBN WHEELS

- Resin and Vitrified Bond, Diamond and cBN Wheels
 - Choose a dressing stick one or two grit sizes finer than the abrasive in the wheel – in a soft grade (H or I).
- Metal Bond, Diamond and cBN Wheels
 - Choose a stick the same grit size or one grit size coarser than the abrasive in the wheel – in a medium grade (K–M).



It is the user's responsibility to refer to and comply with ANSI B7.1



Vitrified Dressing Sticks

Aluminum Oxide (White)

For dressing and cleaning cBN wheels; these sticks also work well for diamond wheels.

Silicon Carbide (Black)

Coarse grit (16 - 46) and hard-grade (R and harder) sticks are used for dressing conventional vitrified wheels. Finer grit and softer grades are used for dressing diamond wheels.

AVAILABILITY			
TIER: BETTER			
SIZE (T X W X L)	STD. PKG.	SPEC.	PART NO.
VITRIFIED DRESSING STICKS – ALUMINUM OXIDE			
3/8 x 3/4 x 4	5	38A150-IVBE	61463639635
1/2 x 1/2 x 4	5	38A220-HVBE	61463610555
1/2 x 1/2 x 6	5	38A150-IVBE	61463610303
		38A220-HVBE	61463610103 B
1/2 x 3/4 x 4	5	38A60-LVBE	61463610415
3/4 x 3/4 x 4	5	38A60-LVBE	61463610440
		38A80-MVBE	61463610362
		38A150-HVBE	61463610291
		38A150-IVBE	61463610368
		38A220-HVBE	61463610290
3/4 x 3/4 x 8	5	38A220-HVBE	61463610280
1 x 1 x 6	5	38A150-HVBE	61463610405
		38A150-IVBE	61463610453
		38A220-HVBE	61463610406 B
1 x 1 x 8	5	38A120-IVBE	61463610390
		38A150-IVBE	61463610455

B = BEST SELLER; PERFORMS WELL IN A VARIETY OF APPLICATIONS FOR MANY SATISFIED CUSTOMERS

Vitrified Superfine Sticks

For dressing superabrasive wheels.

AVAILABILITY					
TIER: BETTER					
SIZE (T X W X L)	STD. PKG.	SPEC.	PART NO.		
VITRIFIED DRESSING STICKS – SILICON CARBIDE					
1/2 x 1/2 x 6	5	37C24-SVK	61463610285		
		37C100-LV	61463610201		
		37C150-KV	61463610205		
		37C150-LV	61463610206		
		37C150-MV	61463610207		
		37C220-KV	61463610214		
		37C150-LV	61463610375		
3/4 x 3/4 x 6	5	37C20-SVK	61463610459		
1 x 1 x 6	5	37C24-SVK	61463610462		
		37C24-TVK	61463610354		
		37C46-RVK	61463610466		
		37C80-NV	61463610393		
		37C150-KV	61463610438		
		37C220-KV	61463610398		
		1 x 1 x 6 (retail carded)	5	S/C Medium Grit	07660710466
		1 x 1 x 8	5	37C20-SVK	61463610469
				37C24-SVK	61463610471
		1 x 2 x 8	5	37C16-TVK	61463610482
		37C24-TVK	61463610485		
2 x 2 x 8	5	37C24-SVK	61463610490		
VITRIFIED ROUND DRESSING STICKS – SILICON CARBIDE					
1/2 x 6	5	37C24-SVK	61463610371		
1 x 6	5	S/C Ex-C (JT276)	61463687905		

AVAILABILITY			
TIER: BETTER			
SIZE (T X W X L)	STD. PKG.	SPEC.	PART NO.
VITRIFIED SUPERFINE STICKS			
1/2 x 1/2 x 6	5	NMVC320-J5VCA	61463610599
		NMVC400-J5VCA	61463650324
1 x 1 x 6	5	NMVC320-J5VCA	61463610605
		NMVC400-J5VCA	61463650450
1 x 1 x 8	5	NSA320-H8V	61463610597

Offhand Grinding Wheel Dressing Stick and Holder

This convenient metal holder is widely used by mechanics and foundry-men for truing, dressing and changing the face of the wheel. The JT246 dressing stick – an extra coarse grit silicon carbide for dressing conventional vitrified wheels – is firmly held and adjusted by the knurled control.

AVAILABILITY					
TIER: BETTER					
SIZE (D X L)	SPEC.	MIN./STD. PKG.	PRODUCT NO.	PART NO.	
OFFHAND GRINDING WHEEL DRESSING STICK AND HOLDER					
1/2 x 6 Round	Silicon Carbide Extra Coarse Grit Round Dressing Stick	5/10	JT246	61463687900	
10 Overall	Dressing Stick Holder	5/10	H6	61463687895	





Rubber Finishing Sticks

These sticks are used for manual or mechanical honing on machines where they are mounted in holders or fixtures. Intended for use where precision dimensional limits and grade controls are required, such as die polishing.

AVAILABILITY

TIER:

BETTER

SIZE (T X W X L)	MIN./STD. PKG.	SPEC.	PART NO.
RUBBER FINISHING STICKS			
1/2 x 1/2 x 6	5/20	57A120-B2RR	61463610608
1/2 x 1 x 6	5/20	57A120-B2RR	61463610609

Blank Stock FastTrack Made-to-Order Microabrasive Superfinishing Sticks



Superfinishing blank stock encompasses a wide range of different specifications. These blanks can be finished to your dimensional requirements within two weeks from the date that the order is received at Norton. Small lots, for test purposes, can be express shipped.

APPLICATIONS	ABRASIVE TYPE – BOND	GRIT RANGE	TREATMENT TYPE
Superfinishing / Finishing and Dressing	NLA – V	240 – 1200	Sulfur, Wax
	NMVC – VCA		
Honing	NSA – V	54 – 220	
	SG – VS		
	SGG – VS1		



CATEGORY DEFINITION

Our extensive offering of stock diamond and cBN electroplated products has been engineered to meet the diverse demands of traditional and emerging tool and die, ceramic, and composite applications.

APPLICATIONS:	Small hole/ID grinding, deburring, cleaning, honing, precision drilling, forming dies and molds, routing, reaming, blending radii, notching and cutting-off with saw blades in ceramic, tool and die, and composite applications
PRODUCTS:	Mounted points, mandrels, drills, routers, contour tools, wheels, files, and saw blades
ABRASIVE GRAIN:	Diamond and cBN (cubic Boron Nitride)

Abrasive Applications

Although diamond and cBN (cubic Boron Nitride) are both superabrasives, the use of diamond and cBN varies, depending upon the materials to be ground.

Diamond Grinds:

- Cemented carbide
- Glass
- Ceramics
- Fiberglass
- Plastics
- Composites
- Abrasives
- Stone
- Electronic components and materials

cBN Grinds:

- High-speed tool steels
- Die steel
- Hardened carbon steels
- Hardened stainless steels
- Alloy steels
- Aerospace alloys
- Abrasion-resistant ferrous materials

In general, cBN is used to grind ferrous materials. Diamond is used to grind non-ferrous materials, because of an adverse reaction between diamond and iron.

TECHtip

COOLANTS

Although coolants may not be necessary, using a coolant produces superior surface finishes, a longer tool life, higher performance, and reduces tool loading.

FEEDS

Suggested feeds for jig or internal grinding are from .0002" – .0004" per pass.

SPEEDS

Maximum Operating Speeds (MOS)

Never exceed the maximum operating speed marked on the superabrasive product being used.

Electroplated Products: 10,000 SFPM

Maximum speeds are a function of the length of overhang and size of the product. Refer to "Safe Operating Speeds" in form #2872, provided with your product.

Recommended Operating Speeds

The preceding speed is the maximum safe speed and not necessarily the most efficient. Superabrasive products operate most effectively at speeds lower than the maximum. The following are general recommendations. cBN products, in many cases, are used effectively at higher speeds.

Electroplated Diamond Products: 5,000 to 10,000 SFPM

Electroplated cBN Products: 8,000 to 10,000 SFPM

Calculating Operating Speed

The following formula may be used to quickly calculate wheel speed: RPM = Revolutions Per Minute
SFPM = Surface Feet Per Minute

To convert SFPM to RPM: (Multiply SFPM x 3.82) divided by wheel diameter in inches

Made-to-Order Electroplated Product Guide

The stock electroplated products offered on the following pages have been engineered to meet the diversity of demands typical in today's manufacturing environment.

When special forms, shapes, and configurations are required, Norton electroplated diamond and cBN products can be fabricated in almost any geometry. In addition, strip and replate services are available.

Customers may prefer to manufacture their own preforms/blanks for custom products and in many cases this can reduce cost and lead-times. The instructions below detail the necessary allowances for each grit size. Please refer to these whenever manufacturing blanks.

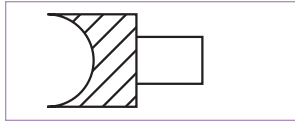

Area to be plated (female radius)

Female radius must be larger than the finished size required.

Example – If a .500 female radius is required with 60/80 grit, then the blank should be manufactured .011 larger = .511

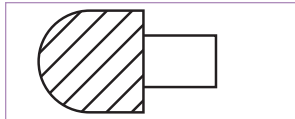

Area to be plated (male radius)

A male radius must be smaller than the finished size required.

Example – If a .500 male radius is required with 60/80 grit, then the blank should be manufactured .011 smaller = .489

Grit Size Allowance for Plated Products

ALLOWANCE/ GRIT SIZE	PARTICLE SIZE
20/30	.035
30/40	.025
40/50	.018
60/80	.011
80/100	.008
100/120	.007
120/140	.006
140/170	.005
170/200	.004
200/230	.0035
270/325	.003
4.5 Micron – 400	.0025
30 Micron – 600	.0016
15 Micron – 1200	.001

THIS SHOULD BE USED AS A GUIDE WHEN MANUFACTURING BLANKS TO BE PLATED WITH DIAMOND OR CBN.

Surface Finish

Use this chart only as a guide. Surface finish is affected by a number of variables: machine type and condition, type of material, coolant, wheel speed, bond system, etc.

Expected RMS Finish

GRIT SIZE	ELECTROPLATED
80	90-125
100	64-90
120	48-64
150	32-48
180	24-32
220	20-24
240	16-20
320	16-20
400	14-20
500	12-13
600	12



Electroplated Mounted Points

DIAMOND AND CBN MOUNTED POINTS ● ▲

FEATURES	BENEFITS
• Nickel alloy matrix	• Tough, durable bond
• Single layer of abrasive	• Economical
• Exposed particles	• Aggressive cutting action
• Variety of tools and grit sizes available as stock	• Satisfy most tool and die and deburring requirements
• Mandrels are made of high-speed tool steel	• Withstand operating pressure

Use Norton diamond mounted points for precise, small hole, jig and internal grinding of carbide, ceramics, sapphire, glass, and a variety of tough, super alloys.

For grinding tough, high carbon, high chrome steel, use cBN mounted points.

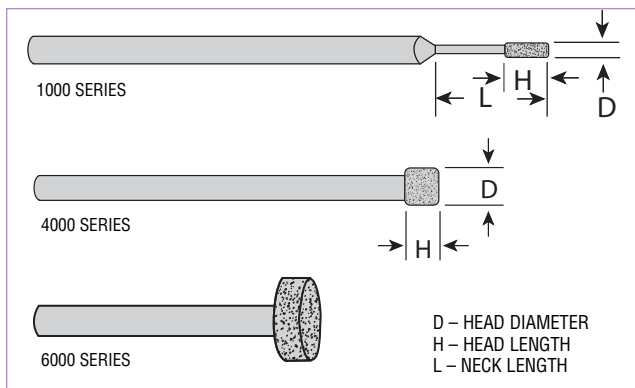

PART NO.	PRODUCT NO.	HEAD DIAMETER INCHES	HEAD LENGTH	NECK LENGTH	GRIT SIZE
1000 SERIES – DIAMOND					
1/8" Shank x 2-1/4" Overall Length					
66260392429	1016FD	.016	.079	1/8	200
66260392432	1020MD	.020	.079	1/8	150
66260392431	1020FD	.020	.079	1/8	200
66260392436	1025MD	.025	.079	1/8	150
66260392435	1025FD	.025	.079	1/8	200
66260392440	1030MD	.030	.079	1/4	150
66260392439	1030FD	.030	.079	1/4	200
66260392445	1035CD	.035	.118	1/4	100
66260392444	1035MD	.035	.118	1/4	150
66260392443	1035FD	.035	.118	1/4	200
66260392451	1040CD	.040	.118	1/4	100
66260392450	1040MD	.040	.118	1/4	150
66260392449	1040FD	.040	.118	1/4	200
66260392457	1045CD	.045	.118	1/4	100
66260392456	1045MD	.045	.118	1/4	150
66260392455	1045FD	.045	.118	1/4	200
66260392463	1050CD	.050	.118	1/2	100
66260392462	1050MD	.050	.118	1/2	150
66260392461	1050FD	.050	.118	1/2	200
66260392469	1050LCD	.050	.118	1	100
66260392468	1050LMD	.050	.118	1	150
66260392467	1050LFD	.050	.118	1	200
66260392475	1055CD	.055	.118	1/2	100
66260392474	1055MD	.055	.118	1/2	150
66260392473	1055FD	.055	.118	1/2	200
66260392481	1060CD	.060	.157	1/2	100

NS NON-STOCK; CONTACT YOUR NORTON REPRESENTATIVE FOR CURRENT LEAD-TIME.
+ AVAILABLE AS STOCK WHILE SUPPLIES LAST; THEN AVAILABLE AS NON-STOCK.

TARGET MARKET SYMBOLS
● = CERAMICS ▲ = TOOL & DIE ■ = COMPOSITES

PART NO.	PRODUCT NO.	HEAD DIAMETER INCHES	HEAD LENGTH	NECK LENGTH	GRIT SIZE
1000 SERIES – DIAMOND (CONTINUED)					
1/8" Shank x 2-1/4" Overall Length					
66260392480	1060MD	.060	.157	1/2	150
66260392479	1060FD	.060	.157	1/2	200
66260392487	1060LCD	.060	.157	1	100
66260392486	1060LMD	.060	.157	1	150
66260392485 +	1060LFD	.060	.157	1	200
66260392493 +	1065CD	.065	.157	1/2	100
66260392492	1065MD	.065	.157	1/2	150
66260392491	1065FD	.065	.157	1/2	200
66260392499	1070CD	.070	.157	1/2	100
66260392498	1070MD	.070	.157	1/2	150
66260392497	1070FD	.070	.157	1/2	200
66260392505	1070LCD	.070	.157	1	100
66260392504 NS	1070LMD	.070	.157	1	150
66260392503 NS	1070LFD	.070	.157	1	200
66260392511	1075CD	.075	.157	1/2	100
66260392510	1075MD	.075	.157	1/2	150
66260392509	1075FD	.075	.157	1/2	200
66260392517	1080CD	.080	.157	1/2	100
66260392516	1080MD	.080	.157	1/2	150
66260392515	1080FD	.080	.157	1/2	200
66260392523	1080LCD	.080	.157	1	100
66260392522 NS	1080LMD	.080	.157	1	150
66260392521	1080LFD	.080	.157	1	200
66260392529	1085CD	.085	.157	1/2	100
66260392528	1085MD	.085	.157	1/2	150
66260392527 NS	1085FD	.085	.157	1/2	200
66260392535	1090CD	.090	.157	1/2	100
66260392534	1090MD	.090	.157	1/2	150
66260392533	1090FD	.090	.157	1/2	200
66260392541	1090LCD	.090	.157	1	100
66260392540	1090LMD	.090	.157	1	150
66260392547	1095CD	.095	.157	1/2	100
66260392546	1095MD	.095	.157	1/2	150
66260392545	1095FD	.095	.157	1/2	200
66260392553	1100CD	.100	.157	1/2	100
66260392552	1100MD	.100	.157	1/2	150
66260392551	1100FD	.100	.157	1/2	200
66260392559	1100LCD	.100	.157	1	100
66260392557	1100LFD	.100	.157	1	200
66260392565	1105CD	.105	.157	1/2	100
66260392564 +	1105MD	.105	.157	1/2	150
66260392563	1105FD	.105	.157	1/2	200
66260392571 NS	1105LCD	.105	.157	1	100

CONTINUED

Electroplated Mounted Points

DIAMOND AND CBN MOUNTED POINTS ● ▲

PART NO.	PRODUCT NO.	HEAD DIAMETER INCHES	HEAD LENGTH	NECK LENGTH	GRIT SIZE
1000 SERIES – DIAMOND (CONTINUED)					
1/8" Shank x 2-1/4" Overall Length					
66260392570 +	1105LMD	.105	.157	1	150
66260392569 +	1105LFD	.105	.157	1	200
66260392577	1110CD	.110	.157	1/2	100
66260392576	1110MD	.110	.157	1/2	150
66260392575 NS	1110FD	.110	.157	1/2	200
66260392583	1110LCD	.110	.157	1	100
66260392581 +	1110LFD	.110	.157	1	200
66260392589	1115CD	.115	.157	1/2	100
66260392588	1115MD	.115	.157	1/2	150
66260392587	1115FD	.115	.157	1/2	200
66260392595	1120CD	.120	.157	1/2	100
66260392594	1120MD	.120	.157	1/2	150
66260392593	1120FD	.120	.157	1/2	200
66260392601	1125CD	.125	.157	1/2	100
66260392600	1125MD	.125	.157	1/2	150
66260392599	1125FD	.125	.157	1/2	200
66260392607	1130CD	.130	.197	1	100
66260392606	1130MD	.130	.197	1	150
66260392605 +	1130FD	.130	.197	1	200
66260392613	1135CD	.135	.236	N/A	100
66260392612	1135MD	.135	.236	N/A	150
66260392611	1135FD	.135	.236	N/A	200
66260392619	1140CD	.140	.236	N/A	100
66260392618 +	1140MD	.140	.236	N/A	150
66260392617 +	1140FD	.140	.236	N/A	200
66260392625	1156CD	.156	.236	N/A	100
66260392624	1156MD	.156	.236	N/A	150
66260392623	1156FD	.156	.236	N/A	200
66260392731	1171CD	.171	.236	N/A	100
66260392730	1171MD	.171	.236	N/A	150
66260392729	1171FD	.171	.236	N/A	200
66260392737	1187CD	.187	.312	N/A	100
66260392736 +	1187MD	.187	.312	N/A	150
66260392735	1187FD	.187	.312	N/A	200
66260392743 +	1203CD	.203	.312	N/A	100
66260392742	1203MD	.203	.312	N/A	150
66260392741	1203FD	.203	.312	N/A	200
66260392749 +	1218CD	.218	.312	N/A	100
66260392748	1218MD	.218	.312	N/A	150
66260392747	1218FD	.218	.312	N/A	200
66260392755	1250CD	.250	.312	N/A	100
66260392754	1250MD	.250	.312	N/A	150
66260392753	1250FD	.250	.312	N/A	200
66260363450	W10MD	.750	.035	N/A	150

1000 SERIES – cBN

1/8" Shank x 2-1/4" Overall Length

66260392430 +	1016FC	.016	.079	1/8	200
66260392434	1020MC	.020	.079	1/8	150
66260392433 +	1020FC	.020	.079	1/8	200
66260392438 NS	1025MC	.025	.079	1/8	150
66260392437 NS	1025FC	.025	.079	1/8	200
66260392442	1030MC	.030	.079	1/4	150
66260392441	1030FC	.030	.079	1/4	200
66260392448 +	1035CC	.035	.118	1/4	100
66260392446 NS	1035FC	.035	.118	1/4	200
66260392454 +	1040CC	.040	.118	1/4	100
66260392453	1040MC	.040	.118	1/4	150

CONTINUED

TARGET MARKET SYMBOLS

● = CERAMICS ▲ = TOOL & DIE ■ = COMPOSITES

PART NO.	PRODUCT NO.	HEAD DIAMETER INCHES	HEAD LENGTH	NECK LENGTH	GRIT SIZE
1000 SERIES – cBN (CONTINUED)					
1/8" Shank x 2-1/4" Overall Length					
66260392452	1040FC	.040	.118	1/4	200
66260392460	1045CC	.045	.118	1/4	100
66260392459 +	1045MC	.045	.118	1/4	150
66260392458 +	1045FC	.045	.118	1/4	200
66260392466	1050CC	.050	.118	1/2	100
66260392465	1050MC	.050	.118	1/2	150
66260392464	1050FC	.050	.118	1/2	200
66260392472 +	1050LCC	.050	.118	1	100
66260392471 +	1050LMC	.050	.118	1	150
66260392478 NS	1055CC	.055	.118	1/2	100
66260392477 +	1055MC	.055	.118	1/2	150
66260392476	1055FC	.055	.118	1/2	200
66260392484	1060CC	.060	.157	1/2	100
66260392483	1060MC	.060	.157	1/2	150
66260392482	1060FC	.060	.157	1/2	200
66260392490 NS	1060LCC	.060	.157	1	100
66260392489 NS	1060LMC	.060	.157	1	150
66260392488 NS	1060LFC	.060	.157	1	200
66260392496	1065CC	.065	.157	1/2	100
66260392494 NS	1065FC	.065	.157	1/2	200
66260392502	1070CC	.070	.157	1/2	100
66260392501	1070MC	.070	.157	1/2	150
66260392500	1070FC	.070	.157	1/2	200
66260392508 NS	1070LCC	.070	.157	1	100
66260392507 NS	1070LMC	.070	.157	1	150
66260392506 NS	1070LFC	.070	.157	1	200
66260392514	1075CC	.075	.157	1/2	100
66260392513 +	1075MC	.075	.157	1/2	150
66260392512	1075FC	.075	.157	1/2	200
66260392520	1080CC	.080	.157	1/2	100
66260392519 NS	1080MC	.080	.157	1/2	150
66260392518 NS	1080FC	.080	.157	1/2	200
66260392526	1080LCC	.080	.157	1	100
66260392525 +	1080LMC	.080	.157	1	150
66260392524 +	1080LFC	.080	.157	1	200
66260392532	1085CC	.085	.157	1/2	100
66260392531	1085MC	.085	.157	1/2	150
66260392530	1085FC	.085	.157	1/2	200
66260392538	1090CC	.090	.157	1/2	100
66260392537	1090MC	.090	.157	1/2	150
66260392536	1090FC	.090	.157	1/2	200
66260392544	1090LCC	.090	.157	1	100
66260392543	1090LMC	.090	.157	1	150
66260392542 +	1090LFC	.090	.157	1	200
66260392550 +	1095CC	.095	.157	1/2	100
66260392549	1095MC	.095	.157	1/2	150
66260392548 +	1095FC	.095	.157	1/2	200
66260392556	1100CC	.100	.157	1/2	100
66260392555	1100MC	.100	.157	1/2	150
66260392554	1100FC	.100	.157	1/2	200
66260392562 +	1100LCC	.100	.157	1	100
66260392561	1100LMC	.100	.157	1	150
66260392560	1100LFC	.100	.157	1	200
66260392568	1105CC	.105	.157	1/2	100
66260392567	1105MC	.105	.157	1/2	150
66260392566 +	1105FC	.105	.157	1/2	200
66260392574 +	1105LCC	.105	.157	1	100
66260392573 +	1105LMC	.105	.157	1	150
66260392572 +	1105LFC	.105	.157	1	200

CONTINUED

+ AVAILABLE AS STOCK WHILE SUPPLIES LAST; THEN AVAILABLE AS NON-STOCK.
NS NON-STOCK; CONTACT YOUR NORTON REPRESENTATIVE FOR CURRENT LEAD-TIMES.

Electroplated Mounted Points

DIAMOND AND CBN MOUNTED POINTS ● ▲

PART NO.	PRODUCT NO.	HEAD DIAMETER INCHES	HEAD LENGTH	NECK LENGTH	GRIT SIZE
1000 SERIES – CBN (CONTINUED)					
1/8" Shank x 2-1/4" Overall Length					
66260392580	1110CC	.110	.157	1/2	100
66260392579 +	1110MC	.110	.157	1/2	150
66260392578	1110FC	.110	.157	1/2	200
66260392586 +	1110LCC	.110	.157	1	100
66260392585	1110LMC	.110	.157	1	150
66260392584 +	1110LFC	.110	.157	1	200
66260392592 +	1115CC	.115	.157	1/2	100
66260392591 +	1115MC	.115	.157	1/2	150
66260392590 +	1115FC	.115	.157	1/2	200
66260392598	1120CC	.120	.157	1/2	100
66260392597 +	1120MC	.120	.157	1/2	150
66260392596 +	1120FC	.120	.157	1/2	200
66260392604	1125CC	.125	.157	1/2	100
66260392603	1125MC	.125	.157	1/2	150
66260392602	1125FC	.125	.157	1/2	200
66260392610	1130CC	.130	.197	1	100
66260392609 +	1130MC	.130	.197	1	150
66260392608	1130FC	.130	.197	1	200
66260392616	1135CC	.135	.236	N/A	100
66260392615	1135MC	.135	.236	N/A	150
66260392614 +	1135FC	.135	.236	N/A	200
66260392622	1140CC	.140	.236	N/A	100
66260392621 +	1140MC	.140	.236	N/A	150
66260392620 +	1140FC	.140	.236	N/A	200
66260392628	1156CC	.156	.236	N/A	100
66260392627	1156MC	.156	.236	N/A	150
66260392626	1156FC	.156	.236	N/A	200
66260392734	1171CC	.171	.236	N/A	100
66260392733	1171MC	.171	.236	N/A	150
66260392732 MS	1171FC	.171	.236	N/A	200
66260392740	1187CC	.187	.312	N/A	100
66260392739	1187MC	.187	.312	N/A	150
66260392738	1187FC	.187	.312	N/A	200
66260392746 +	1203CC	.203	.312	N/A	100
66260392745	1203MC	.203	.312	N/A	150
66260392744 MS	1203FC	.203	.312	N/A	200
66260392752	1218CC	.218	.312	N/A	100
66260392751	1218MC	.218	.312	N/A	150
66260392750 +	1218FC	.218	.312	N/A	200
66260392758	1250CC	.250	.312	N/A	100
66260392757	1250MC	.250	.312	N/A	150
66260392756 +	1250FC	.250	.312	N/A	200
4000 SERIES – DIAMOND					
1/4" Shank x 3" Overall Length					
66260392630	4156CD	.156	.250	1	100
66260392629	4156FD	.156	.250	1	200
66260392634	4187CD	.187	.250	1	100
66260392633	4187FD	.187	.250	1	200
66260392638	4203CD	.203	.250	1	100
66260392637	4203FD	.203	.250	1	200
66260392642	4218CD	.218	.250	1	100
66260392641	4218FD	.218	.250	1	200
66260392646	4236CD	.236	.250	1	100
66260392645	4236FD	.236	.250	1	200
66260392650	4250CD	.250	.250	1	100
66260392649	4250FD	.250	.250	1	200
66260392654	4282CD	.282	.250	N/A	100
66260392653	4282FD	.282	.250	N/A	200
66260392658	4312CD	.312	.375	N/A	100

CONTINUED

PART NO.	PRODUCT NO.	HEAD DIAMETER INCHES	HEAD LENGTH	NECK LENGTH	GRIT SIZE
4000 SERIES – DIAMOND (CONTINUED)					
1/4" Shank x 3" Overall Length					
66260392657	4312FD	.312	.375	N/A	200
66260392662	4375CD	.375	.375	N/A	100
66260392661	4375FD	.375	.375	N/A	200
66260392666	4390CD	.390	.375	N/A	100
66260392665	4390FD	.390	.375	N/A	200
66260392670	4406CD	.406	.375	N/A	100
66260392669 +	4406FD	.406	.375	N/A	200
66260392674	4437CD	.437	.375	N/A	100
66260392673 +	4437FD	.437	.375	N/A	200
66260392678	4500CD	.500	.375	N/A	100
66260392677	4500FD	.500	.375	N/A	200
66260392682	4730CD	.730	.375	N/A	100
66260392681 +	4730FD	.730	.375	N/A	200
66260392686	4864CD	.864	.375	N/A	100
66260392685 +	4864FD	.864	.375	N/A	200
66260392690	41000CD	1.000	.375	N/A	100
66260392689	41000FD	1.000	.375	N/A	200
4000 SERIES – cBN					
1/4" Shank x 3" Overall Length					
66260392632	4156CC	.156	.250	1	100
66260392631	4156FC	.156	.250	1	200
66260392636	4187CC	.187	.250	1	100
66260392635	4187FC	.187	.250	1	200
66260392640	4203CC	.203	.250	1	100
66260392639	4203FC	.203	.250	1	200
66260392644	4218CC	.218	.250	1	100
66260392643	4218FC	.218	.250	1	200
66260392648	4236CC	.236	.250	1	100
66260392647	4236FC	.236	.250	1	200
66260392652	4250CC	.250	.250	1	100
66260392651	4250FC	.250	.250	1	200
66260392656	4282CC	.282	.250	N/A	100
66260392655	4282FC	.282	.250	N/A	200
66260392660	4312CC	.312	.375	N/A	100
66260392659	4312FC	.312	.375	N/A	200
66260392664	4375CC	.375	.375	N/A	100
66260392663	4375FC	.375	.375	N/A	200
66260392668	4390CC	.390	.375	N/A	100
66260392667	4390FC	.390	.375	N/A	200
66260392672	4406CC	.406	.375	N/A	100
66260392671	4406FC	.406	.375	N/A	200
66260392676	4437CC	.437	.375	N/A	100
66260392675	4437FC	.437	.375	N/A	200
66260392680	4500CC	.500	.375	N/A	100
66260392679	4500FC	.500	.375	N/A	200
66260392684	4730CC	.730	.375	N/A	100
66260392683	4730FC	.730	.375	N/A	200
66260392688 +	4864CC	.864	.375	N/A	100
66260392687 +	4864FC	.864	.375	N/A	200
66260392692	41000CC	1.000	.375	N/A	100
66260392691 MS	41000FC	1.000	.375	N/A	200

+ AVAILABLE AS STOCK WHILE SUPPLIES LAST; THEN AVAILABLE AS NON-STOCK.

MS NON-STOCK; CONTACT YOUR NORTON REPRESENTATIVE FOR CURRENT LEAD-TIMES.

TARGET MARKET SYMBOLS

● = CERAMICS ▲ = TOOL & DIE ■ = COMPOSITES

Electroplated Mounted Points, Mandrels and Tapered Hones

DIAMOND AND CBN MOUNTED POINTS ● ▲

PART NO.	PRODUCT NO.	HEAD DIAMETER INCHES	HEAD LENGTH	GRIT SIZE
6000 SERIES – DIAMOND				
3/8" Shank x 3-3/4" Overall Length				
66260392694	6406CD	.406	.375	80
66260392693	6406MD	.406	.375	150
66260392698	6437CD	.437	.375	80
66260392697	6437MD	.437	.375	150
66260392702	6500CD	.500	.375	80
66260392701	6500MD	.500	.375	150
66260392706	6562CD	.562	.375	80
66260392710	6625CD	.625	.375	80
66260392709	6625MD	.625	.375	150
66260392714 +	6687CD	.687	.375	80
66260392713 +	6687MD	.687	.375	150
66260392718	6750CD	.750	.375	80
66260392717	6750MD	.750	.375	150
66260392722 +	6875CD	.875	.400	80
66260392721	6875MD	.875	.400	150
66260392726	61000CD	1.000	.500	80
66260392725	61000MD	1.000	.500	150

PART NO.	PRODUCT NO.	HEAD DIAMETER INCHES	HEAD LENGTH	GRIT SIZE
6000 SERIES – cBN				
3/8" Shank x 3-3/4" Overall Length				
66260392696	6406CC	.406	.375	80
66260392695	6406MC	.406	.375	150
66260392700	6437CC	.437	.375	80
66260392699	6437MC	.437	.375	150
66260392704	6500CC	.500	.375	80
66260392703	6500MC	.500	.375	150
66260392708	6562CC	.562	.375	80
66260392707 +	6562MC	.562	.375	150
66260392712	6625CC	.625	.375	80
66260392711	6625MC	.625	.375	150
66260392716	6687CC	.687	.375	80
66260392715	6687MC	.687	.375	150
66260392720	6750CC	.750	.375	80
66260392719	6750MC	.750	.375	150
66260392724	6875CC	.875	.400	80
66260392723 NS	6875MC	.875	.400	150
66260392728	61000CC	1.000	.500	80
66260392727	61000MC	1.000	.500	150

9000 SERIES – DIAMOND				
3/4" Shank x 3-3/4" Overall Length				
66260308354	91000CD	1.000	.500	80

cBN HEAVY STOCK REMOVAL MANDRELS ▲

FEATURES	BENEFITS
• Nickel alloy matrix	• Tough, durable bond
• Single layer of abrasive	• Economical
• Exposed particles	• Aggressive cutting action
• Super coarse abrasive grit	• Long tool life

For heavy stock removal on jig, internal, and offhand operations on tool steels and hardened aerospace alloys.

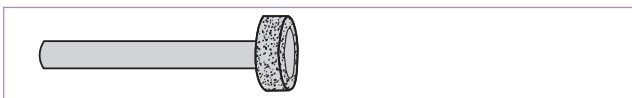

PART NO.	PRODUCT NO.	HEAD DIAMETER	HEAD LENGTH	SHANK DIAMETER	OVERALL LENGTH	GRIT SIZE
HSR SERIES – cBN						
66260395426	HSR-1/4	1/4	1/4	3/8	3	60
66260395427	HSR-5/16	5/16	5/16	3/8	3	60
66260395428	HSR-3/8	3/8	3/8	3/8	3	60
66260395429	HSR-1/2	1/2	3/8	3/8	3-1/2	60
66260395430 +	HSR-5/8	5/8	3/8	3/8	3-1/2	60
66260395431	HSR-3/4	3/4	3/8	3/8	3-1/2	60
66260395432	HSR-1	1	3/8	3/8	3-1/2	60

DIAMOND TAPERED HONES FOR DRAWING DIES ● ▲ ■

FEATURES	BENEFITS
• Nickel alloy matrix	• Tough, durable bond
• Single layer of abrasive	• Economical
• Exposed particles	• Aggressive cutting action

Used primarily for forming carbide drawing dies, but also can be used for small hole honing in ceramics, fiberglass, plastics, and composite materials.

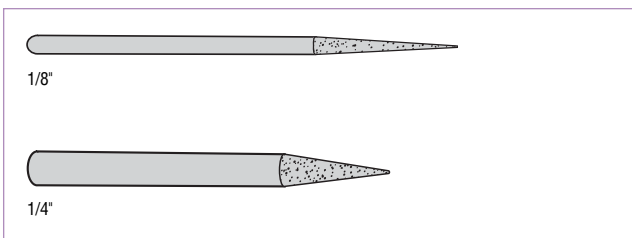

PART NO.	PRODUCT NO.	INCLUDED ANGLE	SHANK DIAMETER	GRIT SIZE
TAPERED HONES FOR DRAWING DIES – DIAMOND				
3" Overall Length				
66260395540	TH12-6MD	6°	1/8	150
66260395541	TH12-8MD	8°	1/8	150
66260363371	TH25-12CD	12°	1/4	100
66260395542	TH12-12MD	12°	1/8	150
66260395543	TH25-12MD	12°	1/4	150
66260395544	TH25-14MD	14°	1/4	150
66260395545	TH25-16MD	16°	1/4	150

TARGET MARKET SYMBOLS		
● = CERAMICS	▲ = TOOL & DIE	■ = COMPOSITES

+ AVAILABLE AS STOCK WHILE SUPPLIES LAST; THEN AVAILABLE AS NON-STOCK.
NS NON-STOCK; CONTACT YOUR NORTON REPRESENTATIVE FOR CURRENT LEAD-TIMES.

Electroplated Micro Drills and Routers

DIAMOND MICRO DRILLS ● ▲ ■

FEATURES	BENEFITS
• Nickel alloy matrix	• Tough, durable bond
• Single layer of abrasive	• Economical
• Exposed particles	• Aggressive cutting action

A modification of Norton mounted points, these tools are specifically designed for drilling holes in the .007" to .065" diameter range. Perfect for drilling sapphire and high density alumina ceramics for hybrid micro-circuit substrates.

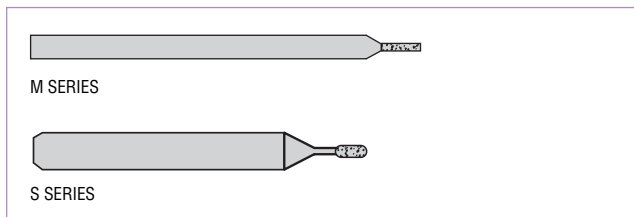

+ AVAILABLE AS STOCK WHILE SUPPLIES LAST; THEN AVAILABLE AS NON-STOCK. *NS* NON-STOCK; CONTACT YOUR NORTON REPRESENTATIVE FOR CURRENT LEAD-TIMES.

PART NO.	PRODUCT NO.	DIAMETER INCHES	HEAD LENGTH	OVERALL LENGTH	GRIT SIZE
M-SERIES MICRO DRILLS – DIAMOND					
Shank Diameter .040" (1mm)					
66260395516	M7	.007	.028	11/16	600
66260395517	M10	.010	.049	11/16	400
66260395518	M12	.012	.056	13/16	325
66260395519	M15	.015	.077	13/16	325

CAREFULLY-SIZED, UNIFORMLY-SHAPED DIAMOND PARTICLES ARE USED ON ALL M-SERIES DRILLS.

PART NO.	PRODUCT NO.	DIAMETER INCHES	HEAD LENGTH	OVERALL LENGTH	GRIT SIZE
S-SERIES MICRO DRILLS – DIAMOND					
1/8" Shank x 1" Overall Length					
66260395520	S16FD	.016	.062	.093	200
66260392841	S18FD	.018	.062	.125	200
66260395521	S20FD	.020	.062	.125	200
66260395522	S25FD	.025	.093	.156	200
66260395523	S30MD	.030	.093	.156	150
66260395524	S35MD	.035	.093	.187	150
66260395525	S40MD	.040	.125	.218	150
66260395526	S45CD	.045	.125	.218	100
66260395527	S50CD	.050	.125	.250	100
66260395528	S60CD	.060	.125	.312	100
66260395529	S65CD	.065	.125	.312	100

RECOMMENDED FOR ADAPTING TO ULTRASONIC DRILL HEADS.

DIAMOND ROUTERS ● ■

FEATURES	BENEFITS
• Nickel alloy matrix	• Tough, durable bond
• Single layer of abrasive	• Economical
• Exposed particles	• Aggressive cutting action

Used with hand operated tools, drill presses, and milling machines. Ideal for routing and reaming the highly-abrasive materials of alumina, fiberglass, plastics, and other nonmetallic composite materials.

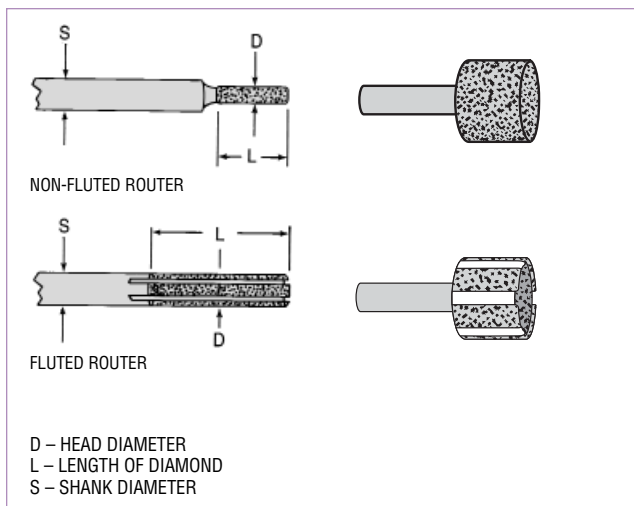

D – HEAD DIAMETER
L – LENGTH OF DIAMOND
S – SHANK DIAMETER

PART NO.	PRODUCT NO.	HEAD DIAMETER	LENGTH OF DIAMOND	SHANK DIAMETER	OVERALL LENGTH	GRIT SIZE
NON-FLUTED ROUTERS – DIAMOND						
66260364305 <i>NS</i>	RNF1812CD	1/8	1/2	1/4	2-1/2	60
66260364304	RNF1810CD	1/8	1	1/4	2-1/2	60
66260364303 +	RNF1412CD	1/4	1/2	1/4	2-1/2	40
66260364302	RNF1410CD	1/4	1	1/4	2-1/2	40
66260302707 <i>NS</i>	RNF3812CD	3/8	1/2	1/2	2-1/2	40
66260302709 <i>NS</i>	RNF3810CD	3/8	1	1/2	2-1/2	40
66260302711 <i>NS</i>	RNF1212CD	1/2	1/2	1/2	2-1/2	40
66260302712 +	RNF1210CD	1/2	1	1/2	2-1/2	40
66260302714 <i>NS</i>	RNF3412CD	3/4	1/2	1/2	2-1/2	40
66260302717 +	RNF3410CD	3/4	1	1/2	2-1/2	40
66260364301 +	RNF1012CD	1	1/2	1/2	2-1/2	40
66260302720 <i>NS</i>	RNF1010CD	1	1	1/2	2-1/2	40
66260302721 +	RNF11212CD	1-1/2	1/2	1/2	3	40
66260302725 <i>NS</i>	RNF2012CD	2	1/2	1/2	3	40
66260302728 +	RNF2010CD	2	1	1/2	3	40

PART NO.	PRODUCT NO.	HEAD DIAMETER	LENGTH OF DIAMOND	SHANK DIAMETER	OVERALL LENGTH	GRIT SIZE
FLUTED ROUTERS – DIAMOND						
66260364310	RSF1812CD	1/8	1/2	1/4	2-1/2	60
66260364309	RSF1810CD	1/8	1	1/4	2-1/2	60
66260364308	RSF1412CD	1/4	1/2	1/4	2-1/2	40
66260364307	RSF1410CD	1/4	1	1/4	2-1/2	40
66260302710 +	RSF3810CD	3/8	1	1/2	2-1/2	40
66260364306 +	RSF1212CD	1/2	1/2	1/2	2-1/2	40
66260302713 +	RSF1210CD	1/2	1	1/2	2-1/2	40
66260302715	RSF3412CD	3/4	1/2	1/2	2-1/2	40
66260302716 +	RSF3410CD	3/4	1	1/2	2-1/2	40
66260302718 +	RSF1012CD	1	1/2	1/2	2-1/2	40
66260302719 +	RSF1010CD	1	1	1/2	2-1/2	40
66260302722 <i>NS</i>	RSF11212CD	1-1/2	1/2	1/2	3	40
66260302724 +	RSF11210CD	1-1/2	1	1/2	3	40
66260302726 <i>NS</i>	RSF2012CD	2	1/2	1/2	3	40
66260302727 +	RSF2010CD	2	1	1/2	3	40

TARGET MARKET SYMBOLS		
● = CERAMICS	▲ = TOOL & DIE	■ = COMPOSITES

Electroplated Mounted Contour Tools

DIAMOND AND CBN MOUNTED CONTOUR TOOLS ● ▲ ■

FEATURES	BENEFITS
• Nickel alloy matrix	• Tough, durable bond
• Single layer of abrasive	• Economical
• Exposed particles	• Aggressive cutting action
• Variety of tool shapes available as stock	• Satisfy most tool and die and deburring requirements

For contour grinding applications on carbide, ceramics, glass, ferrites, and many tough alloys and cements. Best suited for blending radii and deburring operations. Operating speeds: 15,000-20,000 RPM range.

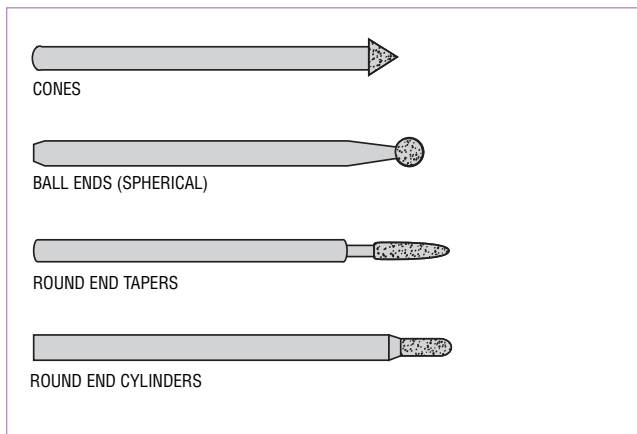

PART NO.	PRODUCT NO.	CONE BASE DIAMETER	INCLUDED ANGLE	CONE LENGTH	GRIT SIZE
CONES – DIAMOND					
1/8" Shank x 2" Overall Length					
66260395484	C14CD	1/8	14°	1/2	100
66260395486 +	C26CD	3/16	26°	13/32	100
66260395488	C35CD	5/32	35°	1/4	100
66260395490	C60CD	11/64	60°	5/32	100
66260395492	C90CD	3/16	90°	3/32	100
CONES – cBN					
1/8" Shank x 2" Overall Length					
66260395483	C14CC	1/8	14°	1/2	100
66260395485	C26CC	3/16	26°	13/32	100
66260395487	C35CC	5/32	35°	1/4	100
66260395489	C60CC	11/64	60°	5/32	100
66260395491	C90CC	3/16	90°	3/32	100

PART NO.	PRODUCT NO.	BALL DIAMETER	GRIT SIZE
BALL ENDS (SPHERICAL) – DIAMOND			
1/8" Shank x 2" Overall Length			
66260395434	BE1CD	3/64	100
66260395436	BE2CD	1/16	100
66260395438	BE3CD	5/64	100
66260395440	BE4CD	3/32	100
66260395442	BE5CD	1/8	100
66260395444	BE6CD	3/16	100
66260395446 +	BE7CD	1/4	100
66260395448	BE8CD	3/8	100
66260395450	BE9CD	1/2	100

PART NO.	PRODUCT NO.	SMALL HEAD DIAMETER	LARGE HEAD DIAMETER	HEAD LENGTH	INC. ANGLE	GRIT SIZE
BALL ENDS (SPHERICAL) – cBN						
1/8" Shank x 2" Overall Length						
66260395433 +	BE1CC	3/64		100		
66260395435 +	BE2CC	1/16		100		
66260395437	BE3CC	5/64		100		
66260395439	BE4CC	3/32		100		
66260395441	BE5CC	1/8		100		
66260395443	BE6CC	3/16		100		
66260395445	BE7CC	1/4		100		
66260395447 <i>NS</i>	BE8CC	3/8		100		
66260395449 +	BE9CC	1/2		100		

PART NO.	PRODUCT NO.	SMALL HEAD DIAMETER	LARGE HEAD DIAMETER	HEAD LENGTH	INC. ANGLE	GRIT SIZE
ROUND END TAPERS – DIAMOND						
1/8" Shank x 2" Overall Length						
66260395506	RT44CD	.044	.066	5/16	4°	100
66260395508 +	RT60CD	.060	.082	5/16	4°	100
66260395510	RT78CD	.078	.110	5/16	6°	100

PART NO.	PRODUCT NO.	HEAD DIAMETER	HEAD LENGTH	GRIT SIZE
ROUND END TAPERS – cBN				
1/8" Shank x 2" Overall Length				
66260395505 <i>NS</i>	RT44CC	.044	.066	5/16 4° 100
66260395507 +	RT60CC	.060	.082	5/16 4° 100
66260395509	RT78CC	.078	.110	5/16 6° 100

PART NO.	PRODUCT NO.	HEAD DIAMETER	HEAD LENGTH	GRIT SIZE
ROUND END CYLINDERS – DIAMOND				
1/8" Shank x 2" Overall Length				
66260395494	RE1CD	1/16	1/4	100
66260395496	RE2CD	5/64	1/4	100
66260395498	RE3CD	3/32	1/4	100
66260395500	RE4CD	1/8	1/4	100
66260395502	RE5CD	3/16	5/16	100
66260395504	RE6CD	1/4	5/16	100

PART NO.	PRODUCT NO.	HEAD DIAMETER	HEAD LENGTH	GRIT SIZE
ROUND END CYLINDERS – cBN				
1/8" Shank x 2" Overall Length				
66260395493	RE1CC	1/16	1/4	100
66260395495	RE2CC	5/64	1/4	100
66260395497 <i>NS</i>	RE3CC	3/32	1/4	100
66260395499	RE4CC	1/8	1/4	100
66260395501 +	RE5CC	3/16	5/16	100
66260395503 +	RE6CC	1/4	5/16	100

TARGET MARKET SYMBOLS
● = CERAMICS ▲ = TOOL & DIE ■ = COMPOSITES

+ AVAILABLE AS STOCK WHILE SUPPLIES LAST; THEN AVAILABLE AS NON-STOCK. *NS* NON-STOCK; CONTACT YOUR NORTON REPRESENTATIVE FOR CURRENT LEAD-TIMES.

Electroplated Grinding Wheels and Files

DIAMOND TYPE 6A2C CUP WHEELS ● ▲

FEATURES	BENEFITS
• Nickel alloy matrix	• Tough, durable bond
• Single layer of abrasive	• Economical
• Exposed particles	• Aggressive cutting action

Extremely fast acting wheels for coarse work (100 grit) and fine finishing (200 grit) of carbide tool bits, etc.

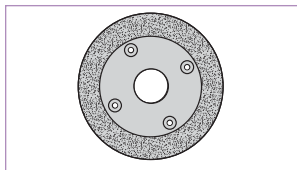

PART NO.	PRODUCT NO.	DIMENSIONS D X T X H	DESCRIPTION	GRIT SIZE
TYPE 6A2C CUP WHEELS WITH MOUNTING HOLES, RIM 1" – DIAMOND				
66260300203NS	6A2CCD	6 x 7/16 x 1-1/4	6A2C Cup Wheel	100
66260300202NS	6A2CFD	6 x 7/16 x 1-1/4	6A2C Cup Wheel	200
66260302135NS		6 x 5/16 x 1-1/4	Back-up Plate 6"	

FOUR 9/32" HOLES ON A 3-1/4" BOLT CIRCLE.

DIAMOND TYPE 1A1 BENCH AND PEDESTAL WHEELS ● ▲

FEATURES	BENEFITS
• Nickel alloy matrix	• Tough, durable bond
• Single layer of abrasive	• Economical
• Exposed particles	• Aggressive cutting action
• Bakelite core	• Lightweight
	• Adaptable to standard bench grinders
• Maintains flat on O.D.	• Eliminates down time for dressing

Ideal for off-hand grinding. These wheels stay flat without dressing for accurate tool edges. Grind carbide, ceramic and other materials more cost effectively than with conventional silicon carbide abrasive wheels. Available in two grit sizes; 100 grit for roughing and 200 grit for finishing.

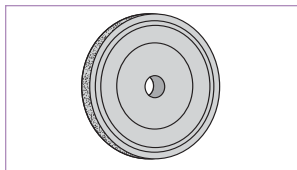

PART NO.	PRODUCT NO.	DIMENSIONS D X T X H	MAX. RPM	GRIT SIZE
TYPE 1A1 BENCH AND PEDESTAL WHEELS – DIAMOND				
66260302087NS	A1PG-CD	6 x 1 x 1	7,635	100
66260302086NS	A1PG-FD	6 x 1 x 1	7,635	200

1/2", 5/8", 3/4" AND 7/8" CENTER HOLE REDUCING BUSHINGS ARE INCLUDED.

TARGET MARKET SYMBOLS

● = CERAMICS ▲ = TOOL & DIE ■ = COMPOSITES

DIAMOND MACHINE FILES ● ▲

FEATURES	BENEFITS
• Nickel alloy matrix	• Tough, durable bond
• Single layer of abrasive	• Economical
• Exposed particles	• Aggressive cutting action

For use in reciprocating hand profiling machines. Ideal for reworking and finishing carbide dies and molds, blending radii, and deburring and cleaning slots and grooves.

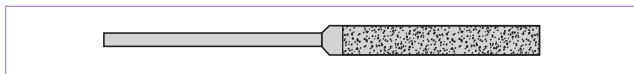

PART NO.	PRODUCT NO.	DIMENSIONS	ABRASIVE LOCATION	GRIT SIZE
MACHINE FILES – DIAMOND				
5/8" Diamond Length, 1/8" Shank, 2" Overall Length				
66260395585	1ECD	.020 x .125		100
66260395586	2ECD	.030 x .125		100
66260395587	3ECD	.040 x .125		100
66260395588 +	2FCD	.079 x .040		100

PART NO.	PRODUCT NO.	DIMENSIONS	ABRASIVE LOCATION	GRIT SIZE
MACHINE FILES – DIAMOND (CONTINUED)				
5/8" Diamond Length, 1/8" Shank, 2" Overall Length				
66260395589	3FCD	.120 x .040		100
66260395590	4FCD	.157 x .040		100
66260395591	5FCD	.203 x .078		100
66260395592	6FCD	.120 x .040		100
66260395593	1CCD	.098 x .196		100
66260395594	2CCD	.120 x .250		100
66260395595	2TCD	.078 side		100
66260395596	3TCD	.127 side		100
66260395597	4TCD	.157 side		100
66260395598	1RCD	.042 diam.		100
66260395599	2RCD	.080 diam.		100
66260395600	3RCD	.127 diam.		100
66260395601	4RCD	.157 diam.		100
66260395602 +	1HRCD	.040 radius		100
66260395603	2HRCD	.060 radius		100
66260395604	3HRCD	.078 radius		100

+ AVAILABLE AS STOCK WHILE SUPPLIES LAST; THEN AVAILABLE AS NON-STOCK. NS NON-STOCK; CONTACT YOUR NORTON REPRESENTATIVE FOR CURRENT LEAD-TIMES.

Electroplated Files

DIAMOND HAND FILES ● ▲

FEATURES

- Nickel alloy matrix
- Single layer of abrasive
- Exposed particles
- Tough, durable bond
- Economical
- Aggressive cutting action

BENEFITS

Indispensable aid for the toolroom. All purpose hand-held tool useful for deburring, notching, dressing, and honing hard, brittle materials.

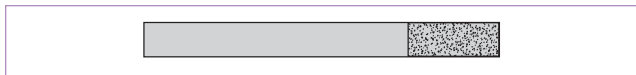

PART NO.	PRODUCT NO.	DIMENSIONS	ABRASIVE LOCATION	GRIT SIZE
HAND FILES – DIAMOND				
6" Overall Length, 1-1/2" Diamond Length				
66260395605	DF1CD	1/8 x 1/8		100
66260392842 +	DF1FD	1/8 x 1/8		200
66260395606	DF2CD	1/8 x 1/4		100

CONTINUED

DIAMOND NEEDLE FILES ● ▲

FEATURES

- Nickel alloy matrix
- Single layer of abrasive
- Exposed particles
- Tough, durable bond
- Economical
- Aggressive cutting action

BENEFITS

Indispensable aid for the toolroom. An all-purpose hand-held tool, useful for deburring, notching, dressing, and honing hard, brittle materials.

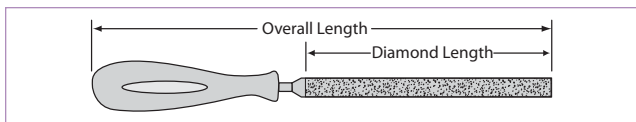

PART NO.	PRODUCT NO.	DIMENSIONS	ABRASIVE LOCATION	SHAPE	GRIT SIZE
NEEDLE FILES – DIAMOND					
4-1/4" Diamond Length, 8-1/2" Overall Length					
66260302432	LNF2CD	.400 x .100		Equaling	100
66260305611	LNF2FD	.400 x .100		Equaling	200
66260302898	LNF3CD	.45 x .150		Half Round	100
66260305612	LNF3FD	.485 x .150		Half Round	200
2-3/4" Diamond Length, 5-3/4" Overall Length, With Handle					
66260391729	1571	.055 x .190		Flat	100
66260391730	1572	.075 x .210		Half Round	100
66260391731	1573	.145 x .145		Triangle	100
66260391732	1574	.100 x .100		Square	100
66260391733	1575	.120		Round	100
66260391734	1576	.055 x .190		Pointed Flat	100
3" Diamond Length, 5-1/2" Overall Length, With Handle					
66260395575	NF1FD	.150 x .105		Oval	200
66260395576	NF2FD	.218 x .072		Half Round	200
66260395577	NF3FD	.205 x .058		Equaling	200
66260395578	NF4FD	.096 x .096		Square	200

TARGET MARKET SYMBOLS

- = CERAMICS
- ▲ = TOOL & DIE
- = COMPOSITES

PART NO.	PRODUCT NO.	DIMENSIONS	ABRASIVE LOCATION	GRIT SIZE
HAND FILES – DIAMOND (CONTINUED)				
6" Overall Length, 1-1/2" Diamond Length				
66260392843	DF2FD	1/8 x 1/4		200
66260395607	DF2WCD	1/8 x 1/4		100
66260395608	DF3CD	1/8 x 3/8		100
66260392844	DF3FD	1/8 x 3/8		200
66260395609	DF3WCD	1/8 x 3/8		100
66260364241	DF3SCD	1/8 x 1/2		100
66260395611	DF4CD	1/8		100
66260392845 NS	DF4FD	1/8		200
66260300134	DF4WCD	1/4		100
66260395613	DF5CD	1/8		100
66260392846	DF5FD	1/8		200
66260395614	DF5WCD	1/4		100
66260395615	DF6CD	1/8		100
66260392847 NS	DF6FD	1/8		200

PART NO.	PRODUCT NO.	DIMENSIONS	ABRASIVE LOCATION	SHAPE	GRIT SIZE
NEEDLE FILES – DIAMOND (CONTINUED)					
3" Diamond Length, 5-1/2" Overall Length, With Handle					
66260395579	NF5FD	.138 x .138		Triangle	200
66260395580	NF6FD	.118		Round	200
66260395581	NF7FD	.197 x .088		Crossing	200
66260395582	NF8FD	.205 x .067		Barrette	200

PART NO.	PRODUCT NO.	GRIT SIZE
NFK-6 NEEDLE FILE KIT – DIAMOND		
66260364008	NFK-6	contains one each of the following:
	NF1FD	200
	NF2FD	200
	NF3FD	200
	NF4FD	200
	NF5FD	200
	NF6FD	200

PART NO.	PRODUCT NO.	GRIT SIZE
DFS-6 DIE FILE KIT – DIAMOND		
66260391830	DFS-6	contains one each of the following:
	1571	100
	1572	100
	1573	100
	1574	100
	1575	100
	1576	100

NEEDLE FILE SHAPE AND APPLICATION KEY:

- Barrette:** A triangle with diamond on the bottom side only
- Crossing:** Elongated oval, with more pointed ends than an oval file; has diamonds all around
- Equaling:** A rectangle with diamond on all four sides; ideal for filing both sides of an ID simultaneously
- Pointed Flat:** A cone with a flat top with diamond on the sides of the cone

+ AVAILABLE AS STOCK WHILE SUPPLIES LAST; THEN AVAILABLE AS NON-STOCK. NS NON-STOCK; CONTACT YOUR NORTON REPRESENTATIVE FOR CURRENT LEAD-TIMES.

Electroplated Drills

DIAMOND CORE DRILLS ● ■

FEATURES	BENEFITS
• Nickel alloy matrix	• Tough, durable bond
• Single layer of abrasive	• Economical
• Exposed particles	• Aggressive cutting action

High performance on glass and ceramic applications while providing fast, reliable cutting. Submersed drilling is highly recommended for optimum operating performance.

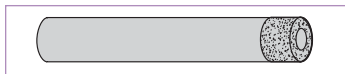

DIAMOND MOUNTED CORE DRILLS ● ■

FEATURES	BENEFITS
• Nickel alloy matrix	• Tough, durable bond
• Single layer of abrasive	• Economical
• Exposed particles	• Aggressive cutting action
• Removable pilot (bulb-like extension)	• Provides added stability • Ensures smooth drilling with less wobbling
• 1/8" wrap: additional 1/8" of electroplated diamond on the blade core	• Increases life of blade on deep cuts, reduces binding and grinding on the core

High performance results on glass and ceramic applications.

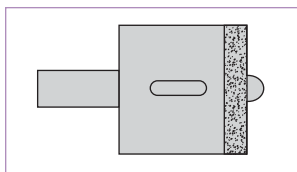

DIAMOND TWIST DRILLS ● ■

FEATURES	BENEFITS
• Nickel alloy matrix	• Tough, durable bond
• Single layer of abrasive	• Economical
• Exposed particles	• Aggressive cutting action

Recommended for precision drilling on circuit boards containing fiberglass, asbestos, nylon, and similar tough, abrasive materials. Diamond twist drills are also useful for drilling plastics and resin composites and have been successful in drilling soft ductile materials as well as "green" carbide. Operating procedures are similar to those of standard twist drills.

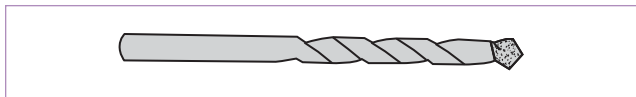

TARGET MARKET SYMBOLS

● = CERAMICS ▲ = TOOL & DIE ■ = COMPOSITES

PART NO.	PRODUCT NO.	OUTER DIAMETER	INNER DIAMETER	GRIT SIZE
CORE DRILLS – DIAMOND				
Straight Tube Type, 2" Overall Length				
66260395530	A1MD	1/16	.023	150
66260395531	A2MD	3/32	.048	150
66260395532	A3MD	1/8	.075	150
66260395533	A4MD	5/32	.110	150
66260395534	A5CD	3/16	.140	100
66260395535	A6CD	1/4	.195	100
66260395536	A7CD	5/16	.255	100
66260395537	A8CD	3/8	.325	100
66260395538 +	A9CD	7/16	.373	80
66260395539	A10CD	1/2	.398	80

PART NO.	PRODUCT NO.	OUTER DIAMETER	PILOT DIAMETER	GRIT SIZE
MOUNTED CORE DRILLS – DIAMOND				
1/8" Wrap, 3/8" Shank Diameter, 3.45" Overall Length				
66260392849	CD.500	1/2	1/8	40
66260392850	CD.750	3/4	1/4	40
66260392851	CD1.000	1	1/4	40
66260392852	CD1.250	1-1/4	1/4	40
66260392853	CD1.500	1-1/2	1/4	40
66260392854 +	CD2.000	2	1/4	40

PILOTS ARE REMOVABLE.

PART NO.	PRODUCT NO.	DRILL DIAMETER	DRILL LENGTH	GRIT SIZE
TWIST DRILLS – DIAMOND				
66260395549	TW-1/16	1/16	1-3/4	100
66260395550	TW-1/8	1/8	2-3/4	100
66260395551	TW-1/4	1/4	4	100
66260395552	TW-3/8	3/8	5	100
66260395553	TW-1/2	1/2	6	100

DIAMETER TOLERANCE EQUALS + OR - 1/64.

+ AVAILABLE AS STOCK WHILE SUPPLIES LAST; THEN AVAILABLE AS NON-STOCK.
MS NON-STOCK; CONTACT YOUR NORTON REPRESENTATIVE FOR CURRENT LEAD-TIMES.

Electroplated Saw Blades

DIAMOND CONTINUOUS RIM CUT-OFF SAW BLADES ■

FEATURES	BENEFITS
• Nickel alloy matrix	• Tough, durable bond
• Single layer of abrasive	• Economical
• Exposed particles	• Aggressive cutting action

Ideal for cutting-off highly-abrasive materials such as alumina, fiberglass, plastics, and other nonmetallic composite materials.

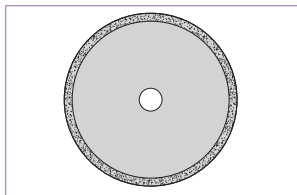

Additional diamond slotted and continuous rim cut-off saw blades, with extended wraps to avoid binding, are available as made-to-order products. Please contact your Norton representative.

PART NO.	PRODUCT NO.	DIAM.	OVERALL THICKNESS	HOLE SIZE	GRIT SIZE
CONTINUOUS RIM CUT-OFF SAW BLADES – DIAMOND					
66260301990	DS2062-250	2	1/16	1/4	40
66260391474	DS2094-250	2	3/32	1/4	40
66260391473	DS3094-250	3	3/32	1/4	40
66260363036	DS3094-375	3	3/32	3/8	40
66260395554	DS4094-500	4	3/32	1/2	40
66260300197	DS4094-750	4	3/32	3/4	40
66260312207 +	DS5094-500	5	3/32	1/2	40
66260395555 +	DS6094-500	6	3/32	1/2	40
66260395556 NS	DS7062-500	7	1/16	1/2	40
66260395557	DS8094-625	8	3/32	5/8	40
66260391464 +	DS10125-625	10	1/8	5/8	40

HOLE SIZES CAN BE ALTERED AT AN ADDITIONAL CHARGE PER WHEEL.

DIAMOND SLOTTED CUT-OFF SAW BLADES ■

FEATURES	BENEFITS
• Nickel alloy matrix	• Tough, durable bond
• Single layer of abrasive	• Economical
• Exposed particles	• Aggressive cutting action
• 3/4" wrap: additional 3/4" of electroplated diamond on the blade core	• Increases life of blade on deep cuts, reduces binding and grinding on the core

Ideal for cutting-off highly-abrasive materials such as alumina, fiberglass, plastics, and other nonmetallic composite materials.

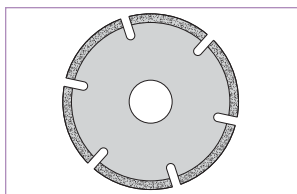

PART NO.	PRODUCT NO.	DIAM.	OVERALL THICKNESS	HOLE SIZE	GRIT SIZE
SLOTTED CUT-OFF SAW BLADES – DIAMOND					
66260301989	DSS2062-250	2	1/16	1/4	40
66260364258	DSS3094-250	3	3/32	1/4	40
66260363015	DSS4094-375	4	3/32	3/8	40
66260395559	DSS4094-500	4	3/32	1/2	40
66260300360 +	DSS4094-750	4	3/32	3/4	40
66260395560	DSS6094-500	6	3/32	1/2	40
66260395561 +	DSS8094-500	8	3/32	1/2	40
66260362981	DSS10125-625	10	1/8	5/8	40
66260395563	DSS12125-500	12	1/8	1/2	40
66260362985 +	DSS12125-1	12	1/8	1	40
66260364253	DSS14156-500	14	5/32	1/2	40
66260362989	DSS14156-1	14	5/32	1	40
66260395565	DSS16156-1	16	5/32	1	40
66260395566	DSS18156-1	18	5/32	1	40
66260395567 NS	DSS20156-1	20	5/32	1	40

SLOTTED CUT-OFF SAW BLADES WITH 3/4" WRAP – DIAMOND

66260313421	DSSW3094-250	3	3/32	1/4	40
66260313422 NS	DSSW4094-500	4	3/32	1/2	40
66260313423	DSSW4094-750	4	3/32	3/4	40
66260313428	DSSW4094-1000	4	3/32	1	40
66260313432	DSSW5094-500	5	3/32	1/2	40
66260313433 NS	DSSW5094-750	5	3/32	3/4	40
66260313434	DSSW5094-1000	5	3/32	1	40

HOLE SIZES CAN BE ALTERED AT AN ADDITIONAL CHARGE PER WHEEL.

TARGET MARKET SYMBOLS

● = CERAMICS ▲ = TOOL & DIE ■ = COMPOSITES

DIAMOND MOUNTED SAW BLADES ■

FEATURES	BENEFITS
• Nickel alloy matrix	• Tough, durable bond
• Single layer of abrasive	• Economical
• Exposed particles	• Aggressive cutting action

Ideal for cutting-off highly-abrasive materials such as alumina, fiberglass, plastics, and other nonmetallic composite materials.

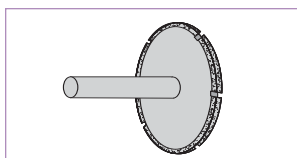

PART NO.	PRODUCT NO.	DIAM.	OVERALL THICKNESS	HOLE SIZE	GRIT SIZE
MOUNTED SAW BLADES – DIAMOND					
2" Overall Length					
66260395422	MDS1CD	1	3/32	1/4	40
66260395423	MDS1-1/2CD	1-1/2	3/32	1/4	40
66260395424	MDS2CD	2	3/32	3/8	40
66260395425	MDS3CD	3	1/8	1/2	40

+ AVAILABLE AS STOCK WHILE SUPPLIES LAST; THEN AVAILABLE AS NON-STOCK.

NS NON-STOCK; CONTACT YOUR NORTON REPRESENTATIVE FOR CURRENT LEAD-TIMES.

DIAMOND LAPPING COMPOUND



CATEGORY DEFINITION

Norton diamond lapping compound polishes all materials – hard and soft. Diamond powders are uniformly distributed in a liquid vehicle for aggressive polishing and consistent part quality. Easy-to-use plastic syringe for quick clean-up.

APPLICATIONS:	For mold, die, and tool polishing, polishing to final tolerance of ceramic parts, initial charging of lapping plates and discs, and other processes that require mirror finish and close tolerance performance.
SYRINGE SIZE:	5 and 18 gram syringes
TYPE:	Water soluble – when soap/water is used for clean-up Oil soluble – when solvent is used for clean-up

PRODUCT NO.	MICRON GRADE	COLOR	PART NO.	
DIAMOND COMPOUND – WATER SOLUBLE				
5 Gram Syringes				
5PS1/4WSSTD	1/4	Ultra Fine	Gray	66260300362
5PS1/2WSSTD	1/2	Ultra Fine	Lt. Gray	66260300417
5PS1WSSTD	1	Ultra Fine	Ivory	66260300368
5PS3WSSTD	3	Super Fine	Yellow	66260300667
5PS6WSSTD	6	Super Fine	Orange	66260300372
5PS9WSSTD	9	Super Fine	Green	66260300375
5PS12WSSTD	12	Super Fine	Aqua	66260300376
5PS15WSSTD	15	Fine	Blue	66260300379
5PS20WSSTD	20	Fine	Auburn	66260300381 +
5PS30WSSTD	30	Fine	Red	66260300383
5PS45WSSTD	45	Fine	Brown	66260300384
5PS60WSSTD	60	Fine	Purple	66260300388
5PS90WSSTD	90	Fine	Black	66260300389
18 Gram Syringes				
18PS1/4WSSTD	1/4	Ultra Fine	Gray	66260300392
18PS1/2WSSTD	1/2	Ultra Fine	Lt. Gray	66260300394
18PS1WSSTD	1	Ultra Fine	Ivory	66260300396
18PS3WSSTD	3	Super Fine	Yellow	66260300398
18PS6WSSTD	6	Super Fine	Orange	66260300400
18PS9WSSTD	9	Super Fine	Green	66260300402
18PS12WSSTD	12	Super Fine	Aqua	66260300404 NS
18PS15WSSTD	15	Fine	Blue	66260300406
18PS20WSSTD	20	Fine	Auburn	66260300408
18PS30WSSTD	30	Fine	Red	66260300410 +
18PS45WSSTD	45	Fine	Brown	66260300412 NS
18PS60WSSTD	60	Fine	Purple	66260300414 NS
18PS90WSSTD	90	Fine	Black	66260300416 NS
Polishing Kit	Kit Includes: four 5 gram syringes of diamond paste: 3u, 6u, 15u, 30u; 4 pieces of substrate; 1 bottle of lubricant			07660702462 NS

PRODUCT NO.	MICRON GRADE	COLOR	PART NO.	
DIAMOND COMPOUND – OIL SOLUBLE				
5 Gram Syringes				
5PS1/4OSSTD	1/4	Ultra Fine	Gray	61463691123 NS
5PS1/2OSSTD	1/2	Ultra Fine	Lt. Gray	66260300363
5PS1OSSTD	1	Ultra Fine	Ivory	61463691133
5PS3OSSTD	3	Super Fine	Yellow	61463691138
5PS6OSSTD	6	Super Fine	Orange	61463691143
5PS9OSSTD	9	Super Fine	Green	61463691148
5PS12OSSTD	12	Super Fine	Aqua	66260300377 NS
5PS15OSSTD	15	Fine	Blue	61463691153
5PS20OSSTD	20	Fine	Auburn	66260300380 NS
5PS30OSSTD	30	Fine	Red	61463691158
5PS45OSSTD	45	Fine	Brown	61463691163
5PS60OSSTD	60	Fine	Purple	66260300386
5PS90OSSTD	90	Fine	Black	66260300390
18 Gram Syringes				
18PS1/4OSSTD	1/4	Ultra Fine	Gray	66260300391
18PS1/2OSSTD	1/2	Ultra Fine	Lt. Gray	66260300393 NS
18PS1OSSTD	1	Ultra Fine	Ivory	61463691134 NS
18PS3OSSTD	3	Super Fine	Yellow	61463691139
18PS6OSSTD	6	Super Fine	Orange	66260300399
18PS9OSSTD	9	Super Fine	Green	61463691149 NS
18PS12OSSTD	12	Super Fine	Aqua	66260300403 NS
18PS15OSSTD	15	Fine	Blue	61463691154
18PS20OSSTD	20	Fine	Auburn	66260300407
18PS30OSSTD	30	Fine	Red	66260300409
18PS45OSSTD	45	Fine	Brown	61463691164 NS
18PS60OSSTD	60	Fine	Purple	66260300413
18PS90OSSTD	90	Fine	Black	66260300415

+ AVAILABLE AS STOCK WHILE SUPPLIES LAST; THEN AVAILABLE AS NON-STOCK.
NS NON-STOCK; CONTACT YOUR NORTON REPRESENTATIVE FOR LEAD-TIMES.

Marking System

5 PS 1/4 OS STD

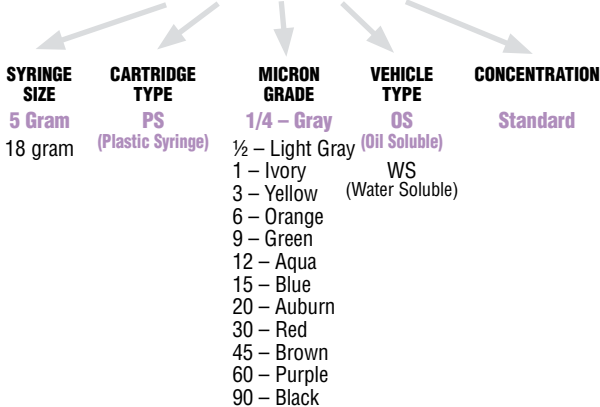

SPECcheck

DIAMOND COMPOUND APPLICATION GUIDE

APPLICATION	MICRON GRADE	MICRON RANGE	MESH SIZE EQUIVALENT	COLOR	CONC.
ULTRA FINE	1/4	(0-1/2)	100,000	Gray	Std.
Applying finest finishes on metals and ceramics	1/2	(0-1)	60,000	Lt. Gray	Std.
	1	(0-2)	14,000	Ivory	Std.
SUPER FINE	3	(2-4)	8,000	Yellow	Std.
Final finishing of dies, molds, seals, most applications (RMS 4-12)	6	(4-8)	3,000	Orange	Std.
	9	(8-12)	1,800	Green	Std.
	12	(9-15)	1,500	Aqua	Std.
FINE FINISH	15	(12-22)	1,200	Blue	Std.
Preparatory lapping (RMS 12-20)	20	(15-25)	800	Auburn	Std.
	30	(22-36)	600	Red	Std.
	45	(36-45)	325	Brown	Std.
	60	(54-80)	230	Purple	Std.
	90	(80-100)	170	Black	Std.

Coated Abrasive Grit Comparison Chart

AVERAGE PARTICLE SIZE IN MICRONS	GRADING SYSTEMS (OTHER THAN EMERY)			EMERY PRODUCTS
	CAMI	FEPA	JIS	
5.0	-	-	-	-
6.0	-	-	3000	-
6.5	1200	-	2500	4/0
8.4	-	P2500	-	-
8.5	-	-	2000	-
9.2	1000	-	-	3/0
10.3	-	P2000	-	-
10.5	-	-	1500	-
12.2	800	-	1200	-
12.6	-	P1500	-	-
15.0	-	-	-	-
15.3	-	P1200	1000	-
16.0	600	-	-	2/0
18.3	-	P1000	800	-
19.7	500	-	-	0
20.0	-	-	-	-
21.8	-	P800	-	-
23.6	400	-	600	-
25.0	-	-	-	-
25.75	-	P600	-	-
28.8	360	-	500	-
30.0	-	P500	-	-
35.0	-	P400	400	-
36.0	320	-	-	-
40.0	-	-	360	-
40.5	-	P360	-	-
44.0	280	-	-	1
45.0	-	-	-	-
46.2	-	P320	320	-
50.0	-	-	-	-
52.5	-	P280	280	-
53.5	240	-	-	-
55.0	-	-	-	-
58.5	-	P240	-	-
60.0	-	-	240	-
64.0	-	-	-	2
65.0	-	P220	220	-
66.0	220	-	-	-
78.0	180	P180	180	-
79.0	-	-	-	3
93.0	150	-	150	-
95.0	-	-	-	FINE
97.0	-	P150	-	-
116.0	120	-	120	-
127.0	-	P120	100	-
136.0	-	-	-	MEDIUM
141.0	100	-	-	-
156.0	-	P100	-	-
189.0	-	-	-	COARSE
192.0	80	-	80	-
197.0	-	P80	-	-
260.0	-	P60	-	-
268.0	60	-	60	-
326.0	-	P50	50	-
341.0	-	-	-	EX. COARSE
351.0	50	-	-	-
412.0	-	P40	40	-
428.0	40	-	-	-
524.0	-	P36	-	-
535.0	36	-	36	-
622.0	-	P30	-	-
638.0	30	-	30	-
715.0	24	-	-	-
740.0	-	P24	24	-
905.0	20	-	-	-
984.0	-	P20	20	-
1320.0	16	-	16	-
1324.0	-	P16	-	-
1764.0	-	P12	-	-
1842.0	12	-	-	-

Backing Types

Backings are the base for the abrasive minerals and, combined with the adhesive bond, support and anchor the abrasive mineral. The backings used in the manufacture of coated abrasives are:

Paper

Due to the fine surface of paper, a consistent finish is produced. Paper weights include *A, B, C, D, E* and *F* weights with *A* being the lightest and most flexible and *F* being the heaviest and least flexible. *A, B, C* and *D* weight papers are used for hand sanding and light mechanical operations in the form of sheets, PSA (pressure sensitive adhesive) and hook and loop discs and sheet rolls. *E* and *F* weight papers are primarily used for more aggressive mechanical operations in the form of belts and discs.

Cloth

Cloth backings used for coated abrasives are identified by weight. Cloth backings are filled or "finished" with a variety of materials (glues or resins) to create various backing characteristics, most notably flexibility. Several cloth types are used: cotton, polyester, polyester/nylon and polyester/cotton blends, and rayon.

There are three basic weights of cloth: J-weight or "jeans" is the lightest and most flexible. X-weight or "drills" is a heavier cloth that ranges in flexibility, strength and durability and is used on the broadest range of applications. Y-weight is a heavyweight drills cloth used on heavy-duty, high stock removal operations.

Fiber

Vulcanized fiber (cotton fibers which are chemically treated and then pressed under temperature and pressure to form a very durable backing) is used exclusively as the backing for resin fiber discs.

Film

Polyester film backing comes in 3 mil. and 5 mil. thicknesses, which have high strength and surface smoothness. They are used primarily in disc and roll applications requiring consistent surface finish.

Bond Types

An adhesive bond system is required to secure the abrasive mineral to the backing. All coated abrasive products are made with a two stage bonding process, the *make coat* and the *size coat*.

The *make coat* is the first layer of bond applied to the backing. The *make coat* provides the adhesive base between the abrasive mineral and the backing.

The *size coat* is the second coat, which is applied over the abrasive mineral and *make coat* to anchor the abrasive mineral and provide the desired physical strength of the finished product.

Glue, urea resin, and phenolic resin are the three basic bonding agents most commonly used. There are many size coat and make coat combinations, such as *glue over glue, urea over glue, and resin over resin*. *Glue over glue* is the most flexible bond while *resin over resin bond* is moisture-resistant, harder, less flexible, heat-resistant and has superior grain retention.

Coating Types

There are two types of abrasive coatings used in the manufacturing of coated abrasives: *open coat* and *closed coat*.

Open Coat

With an open coat, 50% to 75% of the surface is covered by abrasive grain. There are evenly spaced voids between the particles of grain, helping reduce the effect of loading caused by wood dust or metal particles.

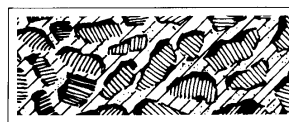

OPEN COAT
(1/3 LESS GRAIN THAN CLOSED)

Closed Coat

With a closed coat, the entire surface is covered with abrasive grain, with no voids between the particles. This is the most typical coating, permitting the greatest degree of stock removal and longest product life.

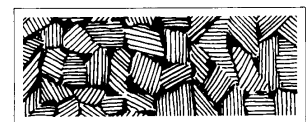

CLOSED COAT

How to Read an Abrasive Product Specification

Conventional Grinding Wheels												
<div style="display: flex; justify-content: space-around; font-weight: bold; background-color: #333; color: white; padding: 5px;"> 32A 46 I 8 V BE </div>												
ABRASIVE		GRIT SIZE			GRADE			STRUCTURE	BOND TYPE	NORTON SYMBOL		
ALUMINUM OXIDE	CERAMIC ALUMINUM OXIDE	SILICON CARBIDE	ZIRCONIA ALUMINA	COARSE	MEDIUM	FINE	SOFT	MEDIUM	HARD	RELATIVE GRAIN SPACING	Resin = B Shellac = E Plastic = P Rubber = R Vitrified = V	Designates a variation or modification to bond.
23A		37C	4NZ	12	30	80	D	I	Q	DENSE		
25A	3SGP	39C	4ZF	14	36	90	E	J	R			
32A	3SGR	Crystolon	5ZF	16	46	100	F	K	S			
32AC (blend)	5SG		AZ (blend)	20	54	120	G	L	T			
38A	BRG		Charger	24	60	150	H	M	U			
48A	SG		(blend)		70	220		N	V			
53A	SXG		NZ					O	Y			
55A	NorZon Plus		NZC (blend)					P	Z			
57A	(blend)		NZIII									
U57A	NQ Quantum		NZIV									
64A			NorZon									
86A												
90A												
FabCut												
Gemini												
Alundum												

Coated Abrasives			
<div style="display: flex; justify-content: space-around; font-weight: bold; background-color: #333; color: white; padding: 5px;"> R 9 8 1 </div>			
BACKING / BOND	PRINCIPAL ABRASIVE	COATING	RANDOM
A = Lightweight Paper (A-D wts.) excluding Waterproof	1 = Aluminum Oxide	1 = Openkote	Designates different products within the same product group.
F = Fiber	2 = Aluminum Oxide	2 = Closekote	
H = Heavy Paper / Resin Bond (E and F wts.)	3 = Layered Aluminum Oxide	3 = Openkote	
K = Cloth / Glue Bond (J and X wts.)	4 = Silicon Carbide	4 = Closekote	
Q = Various (e.g. Screen-Bak and Film)	5 = Garnet	5 = Openkote	
R = Cloth / Resin Bond (H, J, X and Y wts.)	6 = Crocus & Emery	6 = Closekote	
T = Waterproof Paper (A, C wts.)	8 = Zirconia Alumina	7 = Openkote	
U = Lightweight Waterproof Paper / Resin Bond	9 = Norton SG - Ceramic Aluminum Oxide	8 = Closekote	
		9 = Openkote	
		0 = Closekote	

Product Warranty

WARRANTY – Norton warrants the products in this catalog to be free from defects in material or workmanship for a period of one year from the date of purchase. Norton’s sole obligation under this warranty shall be to repair or replace, at Norton’s option, any product which is non-conforming provided any such product failure was not caused by a subsequent modification of the product, misuse or a failure to follow any applicable instructions for the product.

EXCEPT FOR THE FOREGOING, NORTON EXPRESSLY DISCLAIMS ALL OTHER GUARANTIES AND/OR WARRANTIES, EXPRESS OR IMPLIED, INCLUDING THE WARRANTIES OF MERCHANTABILITY AND FITNESS FOR A PARTICULAR PURPOSE.

Product Quality Complaints

All product quality complaints should be submitted to your local Norton Distributor.

Liability Limitation

NORTON’S LIABILITY FOR ANY LOSS OR DAMAGE ARISING OUT OF OR RESULTING FROM THE USE OF THE PRODUCT SHALL NOT EXCEED THE PURCHASE PRICE THEREOF, REGARDLESS OF WHETHER SUCH LIABILITY ARISES IN CONTRACT, TORT (INCLUDING WITHOUT LIMITATION NEGLIGENCE OR STRICT LIABILITY), OR OTHERWISE, AND IN NO EVENT SHALL NORTON BE LIABLE FOR INDIRECT, SPECIAL, INCIDENTAL OR CONSEQUENTIAL DAMAGES OF ANY KIND. NO REPRESENTATIVE OF NORTON, NOR ANY OF NORTON’S DISTRIBUTORS OR DEALERS, IS AUTHORIZED TO MODIFY THIS WARRANTY OR ISSUE ANY WARRANTY REGARDING THE PRODUCTS IN THIS CATALOG.

Trademarks

All trademarks used in these pages are trademarks of Saint-Gobain Abrasives unless otherwise indicated.

3X™	GEMINI®	NORTON DESIGN®	SHURSTIK™
ABRASOTEX™	G-FORCE™	NORTON SG®	SILVER EAGLE®
ADALOX®	GLOBAL™	NORTON SG BLAZE®	SOFTTOUCH®
ALUNDUM®	GREENLYTE™	NORZON®	SPEED CHANGE™
AERO-JET™	GRIND-O-FLEX™	NORZON BLUEFIRE®	SPEED-LOK®
AMPLEX®	INDIA®	NORZON PLUS®	STICK & SAND®
AVOS®	JOBPACK™	OPENKOTE®	TARGA®
AZTEC®	LIGHTNING®	PACESETTER®	THE ABSOLUTE FORCE™
AZTEC II®	LONG LIFE™	PLYWELD®	THE SEE-THRU SYSTEM™
BEAR-TEX®	MERIT®	POLYBOND™	TUFBAK®
BLACK ICE®	METALITE®	POWERFLEX®	TWINFIBER™
BLUE-BAK™	MINI-DEX™	POWERLOCK®	TWINSTAR™
CHARGER™	MSL®	POWERSTRIP™	U-DEX-IT™
CLEAR CREEK™	MULTI-AIR®	PURESAND®	UNIVEL®
CLOSEKOTE®	MULTI-AIR® PLUS™	QUANTUM™	USB™
CRYSTOLON®	MULTI-OILSTONE®	QUADRO-FIT PRO™	VORTEX®
DRYICE®	MULTISAND™	RAILCUT™	WINTER®
DUO®	NEX™	RAPIDCUT™	WOODSAND™
DURITE®	NO-FIL®	RAPID FINISH™	AND OTHERS
EDGER™	NORAX®	RAPID STRIP™	
E-Z FLEX®	NORBIDE®	RESCUE RUNNER™	
FABCUT™	NORKUT™	RIGHTCUT™	
FASTCUT™	NORGRIP®	SAABA™	
FLEXDRUM™	NORLOK™	SAND-O-FLEX™	
FLEXEDGE™	NORPOR®	SANDWET™	
FURIOSO™	NORTON®	SCREEN-BAK®	

Safety – It’s the Smart Thing to Do



SPEEDS

Check machine spindle speed and speed listed on machine against safe maximum operating speed marked on the grinding wheel. Do not overspeed the wheel.



FACE PROTECTION

Always wear government-approved face and eye protection when using abrasive products.



SAFETY GLOVES

Grinding applications are conducted in harsh environments. The use of proper fitting gloves is recommended



WHEEL GUARD

Always use the wheel guard as supplied by the machine manufacturer, in the proper position.

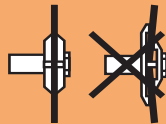

FLANGES

When mounting most grinding wheels, use flanges of equal diameter and bearing surface. For exceptions, see ANSI B7.1.



HEARING PROTECTION

Use of abrasive products might create elevated sound levels. Hearing protection must be worn where required.



SAFETY GUIDES, MSDS AND WHEEL WARNING MESSAGES

Before using any abrasive materials, READ:

- The Safety Guides
- Wheel Warning Messages
- Material Safety Data Sheets (MSDS)

Norton provides information pertaining to the safe use of all products. Please take the time to read it carefully. Contact suppliers of the workpiece and abrasive materials for copies of the MSDS if one is not readily available. Norton abrasives MSDS can be obtained on www.nortonabrasives.com



DUST PROTECTION

Exposure to dust generated from workpiece and/or abrasive materials can result in lung damage and/or other physical injury.

Use dust capture or local exhaust as stated in the MSDS. Wear government-approved respiratory protection and eye and skin protection.

Failure to follow this warning can result in serious lung damage and/or physical injury.

This is a general dust warning and does not cover specific situations. For more information, refer to the MSDS dust warning provided with your products, and workpiece.



WARNING

This warning icon appears on our products and packaging. It is intended to draw your attention to the specific safety warning practices outlined after it.



PISTOL GRIP AIR SANDER

A DEADLY EQUATION

Pistol Grip Air Sander + Grinding Wheel = Certain Injury!

- Never use a high speed air sander as a portable grinder
- Use only sanding discs specifically designed for sanders
- Because the speed of these sanders far exceeds the maximum rated speeds for grinding wheels, a potentially lethal wheel breakage may occur

Starting a Grinding Wheel

ANSI's Procedure for Starting an Abrasive Wheel

In the past several years we have heard of wheel breakages and accidents involving abrasive wheels breaking on start-up. This article is designed to remind users of the proper procedure when starting a machine with a new abrasive wheel mounted on it, or starting a machine after the machine and wheel have been stored for a period of time, or remounting a wheel. ANSI B7.1-2000 requires the following procedure when starting a newly mounted grinding wheel.

9.8 Starting the Wheel (Requirements)

All abrasive wheels shall be run at operating speeds with the safety guard in place or in a protected enclosure for at least one minute before applying work. During this time no one shall stand in front of or in line with the wheel. (See section 4, for safety guard requirements.) This provision shall apply each time one of the following conditions occur: a) a new wheel has been mounted; or b) a used wheel has been remounted.

E 9.8 Starting the Wheel (Explanatory Information)

An abrasive wheel may be damaged in shipment or storage, or the wheel may be subjected to improper, excessive stresses during

mounting. Wheels which have been damaged or are under excessive stress, are likely to fracture within the first minute of rotation at operating speed. While this procedure is most important at the time when an abrasive wheel is mounted or remounted, damage may also occur to a wheel during a shut down of the machine on which it is mounted. The user should evaluate the circumstances and length of machine shut down to determine additional times that the operating rule should be followed.

Improper wheel mounting is a major cause of wheel breakages. Always use proper mounting procedures as outlined in ANSI B7.1, machine manufacturer's instructions and those supplied with the abrasive wheel. Be safe, know and follow the rules!

For additional information on this topic or any other abrasive product safety information, please review ANSI, OSHA and literature provided by the grinding wheel and machine manufacturer. You may also contact the Saint-Gobain Product Safety Department at Tel. (508) 795-2317 or Fax. (508) 795-5120 or your Saint-Gobain Abrasives, Inc. representative with any abrasive safety related questions.



What You Should Know About Grinding Wheel Guards

Reports indicate customers in the grinding wheel industry break approximately one grinding wheel per day. Most of these breakages are caused by human error, do not result in personal injury, and generally go unreported. Grinding wheel guards are one of the key components in keeping these grinding wheel mishaps from becoming a personal injury.

Dangerous Conditions Caused by the Ineffective Use of Grinding Wheel Guards:

- Incorrect:** Cup wheels such as Type 6 and 11 used on a portable angle grinder with a Type 27, 28 and 29 depressed center grinding wheel guard.
- Explanation:** While a properly adjusted Type 27, 28 and 29 guard works with a Type 27, 28 or 29 wheel, it offers little or no protection with a Type 6 or 11 cup wheel. The cup wheel "hangs" below the guard meant for a Type 27, 28 or 29 wheel and in the event of a wheel breakage; it offers little or no protection.
- Incorrect:** Type 01 straight cut-off wheels used on a portable angle grinder with a Type 27, 28 or 29 depressed center grinding wheel guard.
- Explanation:** Type 27, 28 and 29 guards are open on the bottom to allow for side grinding with raised hub/depressed center wheels. When side grinding with the Type 27, 28 or 29 wheel, the workpiece acts as a portion of the guard, protecting the operator in the event of a wheel breakage. Cut-off wheels are not designed for use on their side and must be used on their outer periphery only. Guards for cut-off wheels must cover a full 180° area on all sides of the wheel. When using a cut-off wheel with a Type 27, 28 or 29 guard, there is no guard on one side of the wheel, protecting the operator in the event of a wheel breakage. Do not use cut-off wheels on angle grinders without the proper guard.
- In Summary:** Grinding wheel guards designed for one type of machine used on another type of machine, or the wrong guards for the type of wheel, are dangerous.

Ineffective Grinding Wheel Guards:

- The most ineffective guard is the one that has been removed from its machine and is sitting in storage. The removal of a wheel guard on a machine in operation is not only extremely dangerous, but illegal.
- Do not alter or cut back a guard. Using a damaged or altered wheel guard is extremely dangerous to the safety of the operator and bystanders. Guards that are altered, cracked, deformed, bent, or severely worn must be replaced. Once a guard has been damaged, it might become ineffective in a future wheel breakage. If a wheel breakage occurs, the guard must be inspected and if there is any sign of damage, the guard must be replaced.
- Machines with missing wheel guard fasteners are also very dangerous. Sometimes during routine machine maintenance the guard fasteners are damaged and not replaced when the machine is reassembled. During a wheel breakage, the missing fasteners might allow the guard to move, become unattached from the machine or open, exposing the operator to being injured by the guard or not containing the wheel fragments in the event of a wheel break.
- A guard made of paper, tin, cloth, wood or other materials not designed to contain wheel fragments might fail when struck by a wheel fragment. Always use the guard that is recommended for the machine and its operation. Never paint or disguise the wrong material for a proper guard.

Guards Not Properly Adjusted:

- A wheel guard that is set too high on a portable angle grinder will allow the wheel to hang below the guard. This improper setting may render the guard useless in the event of a wheel breakage.
- The wheel guard of a portable machine positioned improperly. A guard used on a portable machine must be positioned so it is located between the operator and the grinding wheel. Also, bystanders must not be positioned in front of the wheel guard's open area.
- Failure to maintain the proper setting of the adjustable tongue guard (AKA spark arrester) on bench, pedestal, or small floor stand grinder. OSHA requires a maximum clearance of 1/4" between the grinding wheel and the tongue guard. If a wheel breakage should occur, maintaining the proper distance will help to contain the wheel fragments and reduce the probability of an injury.

Proper Grinding Wheel Operating Speeds and Safety!

As abrasive wheel producers have known for many years, most grinding wheel breakages and injuries are caused by one major oversight. That oversight is operating a grinding wheel in an over-speed condition. A grinding wheel should never be operated at speeds greater than the wheel's rated speed.

- Never use a grinding wheel with a rated speed less than that of the grinder
- Never mount grinding wheels on sanders (Pistol Grip Air Sanders)
- Never mount grinding wheels directly on electric motors
- Never mount grinding wheels on the wrong size machine for the grinding wheel
- Always properly maintain your machine: especially governors on pneumatic machines and linkage on floorstand machines
- Never use the incorrect air, hydraulic or electric power supply
- Never use the improper speed setting on a machine

What you might not be cognizant of is that slight over-speed can cause damage to a wheel. If an operator continues to use this damaged wheel, it might break. In a reinforced wheel for example, cracks might form, be forced open and jam or catch the wheel on the workpiece resulting in a wheel breakage. The use of a 9" Type 27 Wheel on a 7" angle grinder is very dangerous! Normal stresses that occur during grinding along with the additional stress caused by over-speed are additive. The act of operating a wheel in a slight over-speed condition is very dangerous. We must understand and communicate this danger.



One of the major forces at work on a grinding wheel is called "centrifugal force." To demonstrate this force take a piece of string and tie a small weight to one end. Hold the other end of the string so the weight will travel in a circle. Rotate the weight and you will feel a pull on the string. The weight tries to fly off in a straight line, but the string holds it and compels it to travel in a circle. This pull on the string is called "centrifugal force." Warning: If you attempt this experiment take all the proper precautions related to the object used to avoid injury to yourself or others.

If you swing the weight at a speed of 50 revolutions per minute (RPM) and could measure the pull on the string at this speed, then increase the swing to 100 revolutions per minute and again measure the pull, you would find the pull was not merely two times greater, but was actually four times greater than it was at one half the speed. Therefore, the force increases exponentially with the speed or RPM.

Centrifugal force increases in proportion to the square of the velocity. Think again of the weight and the string. We find that the square of 50 is 2,500, ($50 \times 50 = 2,500$); and the square of 100 is 10,000, ($100 \times 100 = 10,000$). As 10,000 is four times as great as 2,500, so is the pull on the string at 100 revolutions per minute four times as great as it was at 50 revolutions per minute.

Centrifugal force applies to grinding wheels in the same manner as the weight to the string. Increasing the RPM or speed beyond the maximum safe operating speed (MOS) might be more dangerous than might be expected. Placing and operating a 9" Type 27 grinding wheel with a maximum operating speed of 6,600 RPM on a 5" right angle grinder with a rated speed of 10,000 RPM represents an over-speed of approximately 1.515 times the wheel's designated speed. The resulting rotational stress caused by the centrifugal force would be approximately 2.3 times greater than the maximum allowed. Add this additional stress to the stresses that occur during normal grinding and even the strongest wheel might break.

In short, NEVER over-speed a grinding wheel. Always compare the speed marked on the wheel or package to make sure the machine's speed is at, or below, the speed or MOS of the grinding wheel. Speed can kill. NEVER over-speed a grinding wheel.



Shelf Life of Grinding Wheels

It has always been Saint-Gobain Abrasives recommendation that resinoid bonded grinding wheels be used within 2 years from the date of manufacture. This recommendation assumes that resinoid bonded grinding wheels have been stored under ideal storage conditions. It might be true that under ideal storage conditions resinoid bonded grinding wheels can survive without any degradation in strength for well over two years. However, it is always wise to suspect any wheels over two years old and have them reinspected or re-speed tested to determine if there has been any degradation in strength. If the wheels are stored under less than ideal conditions, they might have a much shorter shelf life depending upon the severity of storage conditions. These same comments also apply to rubber and shellac bonded grinding wheels.

As for vitrified grinding wheels, the shelf life is less influenced by humidity and adverse storage conditions as compared to resinoid, rubber or shellac, but even vitrified grinding wheels do not have an infinite shelf life. The best procedure and the best rule of thumb is to have any wheel that is two years old or older re-speed tested and reinspected to ensure it is fit for use. The procedure for having this done and the charges will be explained by our Customer Service Department, but the cost of shipping as well as the cost of reinspection is the customer's responsibility. Also, any wheels rejected or otherwise lost in the reinspection process will also be the responsibility of the customer.

Keep in mind, however, that this procedure is good to verify the reliability of a product but must not be performed until you are ready to consume the wheel. If wheels are sent back after the two year time frame for reinspection and re-testing and then put back on the shelf, there is no telling how long they will be fit for use after that last inspection. Therefore, these wheels must be consumed as soon as is practical.

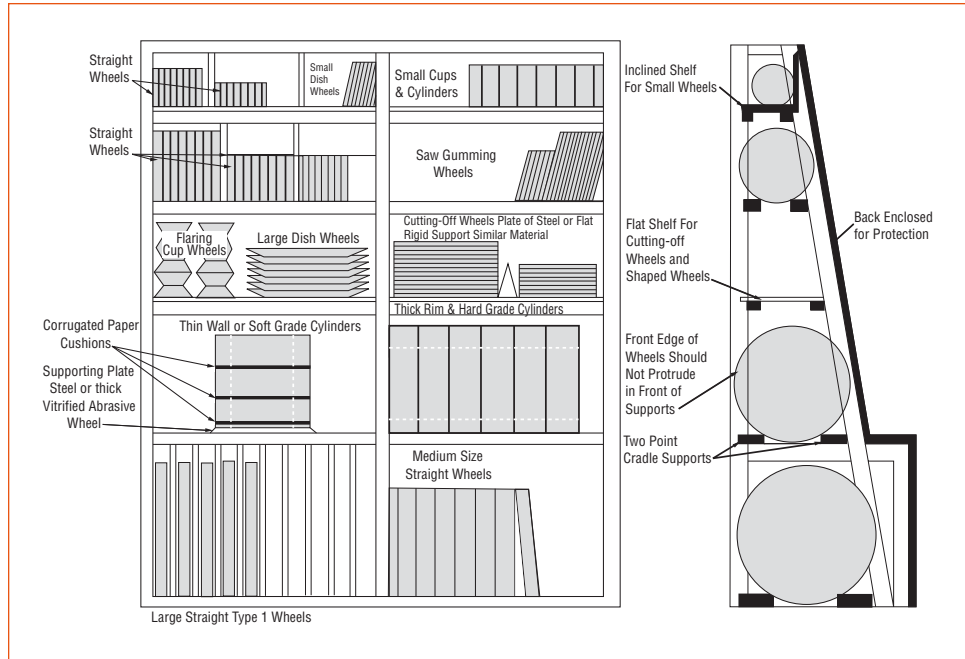

How to Perform a Ring Test on a Grinding Wheel

One method of grinding wheel inspection is called ring testing. OSHA, ANSI and the grinding wheel manufacturers require this method of grinding wheel inspection. It must be performed BEFORE the wheel is mounted on a grinding machine. Ring testing depends on the damping characteristics of a cracked wheel to alter the sound emitted when the wheel is tapped lightly. It is subject to interpretation by the inspector and is primarily applicable to vitrified bonded wheels. To perform the ring test, wheels should be tapped gently with a light nonmetallic implement, such as the handle of a screw driver for light wheels, or a wooden mallet for heavier wheels.

- Tap wheels about 45 degrees each side of the vertical line and about 1" or 2" from the periphery. Rotate the wheel 45 degrees and repeat the test.
- Large and thick wheels may be given the ring test by striking the wheel on the periphery rather than the side of the wheel.
- A sound and undamaged wheel will give a clear tone. If cracked, there will be a dead sound and not a clear ring and the wheel should not be used.
- Wheels must be dry and free of sawdust when applying the ring test, otherwise the sound may be deadened. The ring test is not applicable to certain wheels because of their size, shape or composition.

Safety Tips

Depressed Center, Cut-off Wheels and Snagging Wheels

DO'S

- Check all wheels for cracks or damage before use
- Check machine speed against established safe operating speed marked on the wheel
- Always use the guard furnished with machine
- Run wheel in a protected area for one minute at operating speed before grinding; stand out of plane of rotation

DON'TS

- Don't use wheels that have been dropped or otherwise damaged
- Don't use heavy side pressure on any thin Type O1 straight cut-off wheel or Type 27 thin depressed center wheel
- Never use a grinding wheel with a rated speed less than that of the grinder

Toolroom Wheels

DO'S

- Check all wheels for cracks or damage before use
- Always use a safety guard and ensure work rest is properly adjusted on bench grinder
- Always handle and store wheels in a careful manner
- Check mounting flanges for equal and correct diameter and use blotters when supplied
- Check machine speed against established safe operating speed marked on wheel

DON'TS

- Don't use a cracked wheel or one that has been dropped or damaged
- Don't exceed recommended operating speeds
- Don't tighten the mounting nut excessively
- Don't jam work into the wheel
- Do not sand wood, plastic or any other non-metallic material on bench and pedestal grinders



What are the Major Causes of Grinding Wheel Breakages?

A grinding wheel is a safe tool when used properly. All grinding wheels are tested in accordance with ANSI B7.1 before Saint-Gobain ships them. However, after the grinding wheels are shipped they might be subjected to any number of abuses and misuses. Listed here are some of the major causes of grinding wheel breakages.

- Using a grinding wheel damaged during transportation, storage or as a result of careless or improper handling. Inspect all grinding wheels before mounting them on a machine. **NEVER MOUNT A DAMAGED GRINDING WHEEL.**
- Selecting the wrong grinding wheel for the job. **DON'T GRIND MATERIAL FOR WHICH THE WHEEL IS NOT DESIGNED.**
- Incorrect machine. **NEVER MOUNT A GRINDING WHEEL ON A MACHINE NOT DESIGNED AND GUARDED FOR THAT GRINDING WHEEL.**
- Machine speed higher than the grinding wheel speed. **NEVER OVER-SPEED A GRINDING WHEEL.**
- Poor machine maintenance. **FAILURE TO PROPERLY MAINTAIN A GRINDING MACHINE CAN CAUSE GRINDING WHEEL BREAKAGES RESULTING IN SERIOUS INJURY OR DEATH.**
- The improper mounting of grinding wheels. See ANSI B7.1 and literature provided for proper mounting procedures.
- Operator carelessness. **ALL GRINDING WHEELS CAN BE BROKEN IF NOT USED PROPERLY.**
- Lack of knowledge or training. **IF YOU DO NOT KNOW HOW TO USE A GRINDING WHEEL OR THE GRINDER, GET HELP!**
- Poor wheel balance caused by the failure to turn off coolant before stopping the grinding wheel. Always spin coolant out of a grinding wheel before shutting the operation down.
- Jamming the work into the grinding wheel.
- Force grinding, so that the motor slows noticeably or the work gets hot.
- Grinding on the wrong surface of a grinding wheel, i.e. grinding on the side of a Type 1 straight grinding wheel.

For additional information on this topic or any other grinding wheel safety information, please review ANSI, OSHA and literature provided by the grinding wheel and machine manufacturer. You may also contact the Saint-Gobain Product Safety Department at Tel. (508) 795-2317 or Fax. (508) 795-5120 for additional product safety information. See "Safety" section on www.nortonabrasives.com.



CONVERSION TABLE – WHEEL SPEEDS
REVOLUTIONS PER MINUTE FOR VARIOUS DIAMETERS OF GRINDING WHEELS TO GIVE SURFACE SPEED IN FEET PER MINUTE AS INDICATED
 (FOR WHEEL MARKING PURPOSES THE CALCULATED RPM FIGURES LISTED BELOW ARE ROUNDED OFF TO THE NEXT 5)

Diameter of Wheel in Inches	Surface Speed in Feet Per Minute (SFPM)																				
	4,000	4,500	5,000	5,500	6,000	6,500	7,000	7,500	8,000	8,500	9,000	9,500	10,000	12,000	12,500	14,200	16,000	16,500	17,000	19,685	20,000
1	15,279	17,189	19,098	21,008	22,918	24,828	26,737	28,647	30,558	32,467	34,377	36,287	38,196	45,836	47,745	54,240	61,116	63,025	64,935	75,190	76,395
2	7,639	8,594	9,549	10,504	11,459	12,414	13,368	14,323	15,278	16,233	17,188	18,143	19,098	22,918	23,875	27,120	30,558	31,510	32,465	37,595	38,195
3	5,083	5,729	6,366	7,003	7,639	8,276	8,913	9,549	10,186	10,822	11,459	12,096	12,732	15,278	15,915	18,080	20,372	21,010	21,645	25,065	25,465
4	3,820	4,297	4,775	5,252	5,729	6,207	6,685	7,162	7,640	8,116	8,595	9,072	9,549	11,459	11,940	13,560	15,278	15,755	16,235	18,800	19,100
5	3,056	3,438	3,820	4,202	4,584	4,966	5,348	5,730	6,112	6,494	6,876	7,258	7,640	9,168	9,550	10,850	12,224	12,605	12,985	15,040	15,280
6	2,546	2,865	3,183	3,501	3,820	4,138	4,456	4,775	5,092	5,411	5,729	6,048	6,366	7,639	7,960	9,040	10,186	10,505	10,820	12,530	12,730
7	2,183	2,455	2,728	3,001	3,274	3,547	3,820	4,092	4,366	4,638	4,911	5,183	5,456	6,548	6,820	7,750	8,732	9,005	9,275	10,740	10,915
8	1,910	2,148	2,387	2,626	2,865	3,103	3,342	3,580	3,820	4,058	4,297	4,535	4,775	5,729	5,970	6,780	7,640	7,880	8,115	9,400	9,550
9	1,698	1,910	2,122	2,334	2,546	2,758	2,970	3,182	3,396	3,606	3,820	4,032	4,244	5,092	5,305	6,030	6,792	7,000	7,215	8,355	8,490
10	1,528	1,719	1,910	2,101	2,292	2,483	2,674	2,865	3,056	3,247	3,438	3,629	3,820	4,584	4,775	5,425	6,112	6,300	6,495	7,520	7,640
12	1,273	1,432	1,591	1,751	1,910	2,069	2,228	2,386	2,546	2,705	2,864	3,023	3,183	3,820	3,980	4,520	5,092	5,250	5,410	6,265	6,365
14	1,091	1,228	1,364	1,500	1,637	1,773	1,910	2,046	2,182	2,319	2,455	2,592	2,728	3,274	3,410	3,875	4,366	4,500	4,640	5,370	5,455
16	955	1,074	1,194	1,313	1,432	1,552	1,672	1,791	1,910	2,029	2,149	2,268	2,387	2,865	2,985	3,390	3,820	3,940	4,060	4,700	4,775
18	849	955	1,061	1,167	1,273	1,379	1,485	1,591	1,698	1,803	1,910	2,016	2,122	2,546	2,655	3,015	3,396	3,500	3,605	4,175	4,245
20	764	859	955	1,050	1,146	1,241	1,337	1,432	1,528	1,623	1,719	1,814	1,910	2,292	2,390	2,715	3,056	3,150	3,245	3,760	3,820
22	694	781	868	955	1,042	1,128	1,215	1,302	1,388	1,476	1,562	1,649	1,736	2,084	2,170	2,465	2,776	2,865	2,950	3,420	3,470
24	637	716	796	875	955	1,034	1,115	1,194	1,274	1,353	1,433	1,512	1,591	1,910	1,990	2,260	2,546	2,625	2,705	3,135	3,185
26	588	661	734	808	881	955	1,028	1,101	1,176	1,248	1,322	1,395	1,468	1,762	1,840	2,090	2,352	2,425	2,495	2,890	2,940
28	546	614	682	750	818	887	955	1,023	1,092	1,159	1,228	1,296	1,364	1,637	1,705	1,940	2,182	2,250	2,320	2,685	2,730
30	509	573	637	700	764	828	891	955	1,018	1,082	1,146	1,210	1,274	1,528	1,595	1,810	2,056	2,100	2,165	2,505	2,545
32	477	537	597	656	716	776	836	895	954	1,014	1,074	1,134	1,194	1,432	1,495	1,695	1,910	1,970	2,030	2,350	2,385
34	449	505	562	618	674	730	786	843	898	955	1,011	1,067	1,124	1,348	1,405	1,595	1,796	1,855	1,910	2,210	2,245
36	424	477	530	583	637	690	742	795	848	902	954	1,007	1,061	1,273	1,330	1,510	1,698	1,750	1,085	2,090	2,120
38	402	452	503	553	603	653	704	754	804	854	904	955	1,006	1,206	1,260	1,430	1,608	1,660	1,710	1,980	2,010
40	382	430	478	525	573	620	669	716	764	812	860	908	956	1,146	1,195	1,355	1,528	1,575	1,625	1,880	1,910
42	366	409	454	500	545	591	636	682	732	775	818	863	908	1,090	1,140	1,295	1,464	1,500	1,545	1,790	1,820
44	347	390	434	478	521	564	608	651	694	737	780	824	868	1,042	1,085	1,235	1,388	1,432	1,475	1,710	1,735
46	333	375	416	458	500	541	582	624	666	708	750	791	832	1,000	1,040	1,180	1,332	1,370	1,410	1,635	1,660
48	318	358	398	438	478	517	558	597	636	676	716	756	796	956	995	1,130	1,272	1,315	1,350	1,565	1,590
53	288	324	360	395	432	468	503	539	576	612	648	683	720	864	900	1,025	1,152	1,189	1,225	1,420	1,440
60	255	287	319	350	387	414	446	478	510	542	574	606	638	774	795	905	1,020	1,050	1,080	1,255	1,275
72	212	239	265	291	318	345	371	398	424	451	477	504	530	637	665	755	849	875	905	1,045	1,060

For intermediate diameters not listed use the formula listed in Section 1.2.10 of ANSI B7.1 (SFPM = .262 x wheel diameter in inches x RPM.)
 To convert meters per second (m/s) to SFPM: m/s x 196.85 = SFPM. To convert SFPM to m/s: SFPM/196.85 = m/s. To convert RPM to SFPM: Wheel Diameter x RPM x 0.262 = SFPM



POINT OF PURCHASE SOLUTIONS THAT MAKE AN IMPACT!



MODULAR DESIGN FOR MIX AND MATCH

PRE-SELECTED PRODUCT ASSORTMENT FOR **OPTIMAL CATEGORY COVERAGE** BY END-USER MACHINES AND APPLICATIONS

FLEXIBLE LAYOUT TO FIT AVAILABLE SPACE



THE **MUSCLE**
BEHIND THE MACHINE.™

GET ACCESS TO THE INDUSTRY'S BEST SELECTION OF ABRASIVE SOLUTIONS!



Norton is confident in the quality and performance of our products. We invite tests against any other brand of abrasive products so you can make your own judgment of the time, labor and money savings advantages of Norton products.

- 1 Tests will be conducted in the users' own plant/shop, on their own machines, using their own workpieces and supervised by a Norton representative.
- 2 If the product tested is completely unsatisfactory, you will receive a full refund.
- 3 If the product tested performs at a lower level than the product presently being used, you will receive an adjustment to make up the difference in performance.
- 4 You are the final judge of performance.

Customer Service

TO PLACE AN ORDER, contact our customer service support center with:

- Customer number and contact name
- Any special shipping needs
- Complete product information:
 - 11-digit Part Number
 - Product description
 - Quantity and unit of measure
 - Price by unit of measure

To ensure minimal errors and faster turnaround, using electronic media is preferred.

Email: abrasivecustomerservice@saint-gobain.com

EDI setup: ediconnection@saint-gobain.com

TEL: **800-551-4413** FAX: **800-551-4416**

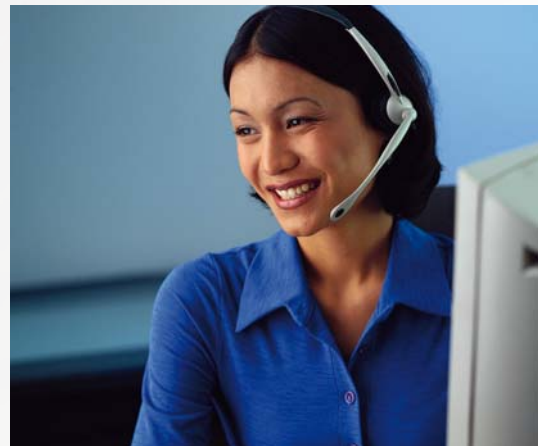

Online

This fully revamped printed catalog is a great starting resource for Norton and Merit product selection. Our website is the ideal resource for a more comprehensive outline of product and application information which is continually updated with all our most current information and offers more electronic queries for deeper detail, at a click of a button.

www.nortonabrasives.com

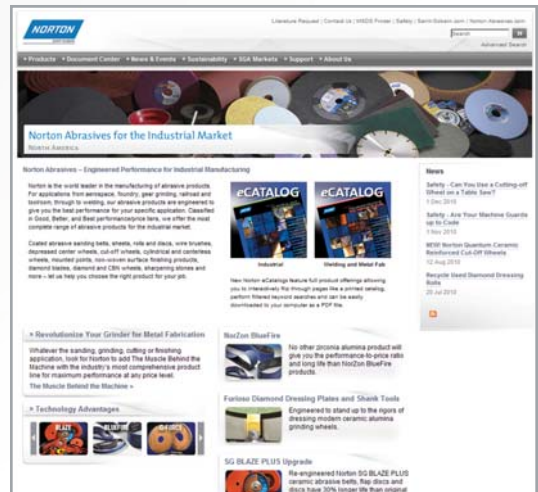

NORTON

SAINT-GOBAIN

THE NORTON FULL LINE OF STOCK ABRASIVE PRODUCTS

www.nortonabrasives.com

For additional items not included in this catalog, please refer to our other market-based catalogs online www.nortonabrasives.com for availability information.

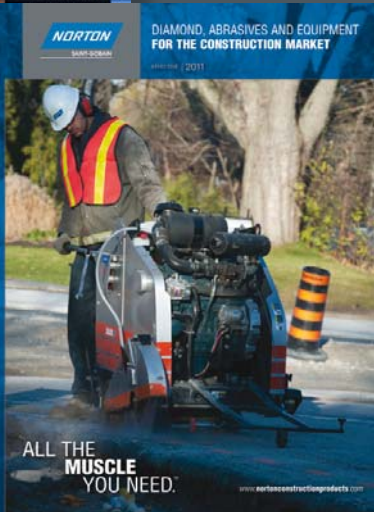
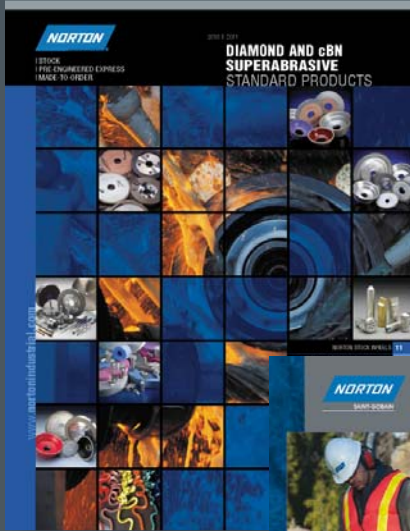

Norton Construction Catalog

FORM #7719



Aggressive Grinding Performance

- NorZon Plus boosts productivity 50-200%
- Lowest total grinding cost with highest productivity
- Ideal for steel, stainless and other ferrous metals



Blaze Your Way to Greater Productivity

- Patented Norton SG ceramic alumina grain
- Supersize treatment for reduced loading and glazing
- Coolest cut with significantly faster cut rates

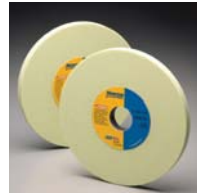

A Quantum Leap in Technology

- Revolutionary ceramic alumina abrasive grain technology
- Aggressive grinding with longer life and higher metal removal rates on materials ranging from cast iron and stainless, to hard-to-grind alloys



Twice the Diamond – Same Great Price!

- Norton B99 1A1 1/8" diamond depth wheels are all now 1/4" depth
- Free-cutting, superior form-holding; efficient wet or dry



Strip / Polish / Finish with One Grinder

- For rapid removal, to prep and clean surfaces
- Open web construction enables rapid cutting action while maintaining a cool, non-loading surface to generate an improved surface finish



Competitive Price without Compromise

- Merit products offer consistent performance with a low initial price
- Quality product at a great value
- Ideal for end-user unable to measure total performance

PRIMARY SPONSOR



NORTON

SAINT-GOBAIN

HEADQUARTERS:
Saint-Gobain Abrasives, Inc.
Industrial Sales
PO Box 15008, 1 New Bond Street
Worcester, MA 01615-0008

U.S. CUSTOMER SERVICE:
Phone Toll Free: 1 800 551-4413
Fax Toll Free: 1 800 551-4416
Local Phone: (254) 918-2313
Local Fax: (254) 918-2314

CANADA CUSTOMER SERVICE:
Phone Toll Free: 1 800 263-6565
Fax Toll Free: 1 800 561-9490

FORM #7362

© Saint-Gobain Abrasives, Inc. February 2011
Norton is a registered trademark of Saint-Gobain Abrasives, Inc.

SAINT-GOBAIN