

Flotec®

Water Is Our Business®

Pump Catalog

2016

Sump

Sewage

Utility

Well





Water Is Our Business®

A global leader in providing innovative products for the movement, treatment and enjoyment of water, Flotec is a widely respected brand of pumps you can trust for performance, quality and long life.

We make sump, lawn and garden, pool and spa, sewage and effluent pumps and home water systems... products you seldom think about, but really appreciate when you need them. Designed for quick and easy installation, all of our products come with industry-leading warranties. We've been making pumps for over 75 years, working to bring you great performance and a quality selection.

Flotec's complete line helps you tackle any pumping project with confidence.



www.flotecwater.com

1-800-365-6832

SUMP PUMPS 4-20

EFFLUENT PUMPS 21-24

SEWAGE PUMPS 25-31

UTILITY PUMPS 32-45

POOL PUMPS 46-47

SPRINKLER PUMPS 48-52

WELL PUMPS and TANKS 53-80

Shallow Well 54-63

Convertible Deep Well 64-68

Submersible Well 69-70

Tanks 71-76

Accessories 77-80

WARRANTY & GLOSSARY 81-82



Flotec®

Sump Pumps

For best defense against flooding, a sump pump removes drainage water that collects in the sump basin located in your basement or crawl space. Replacing a sump pump typically can take about 30 minutes to 1 hour and can be done with common household tools.

Product Line Overview

Submersible and pedestal pumps

Vertical and tethered switches

1/4 HP to 1 HP ranges, up to 6,660 GPH

Battery-powered backup sump pump systems

Complete sink pump system available

1-year to 5-year warranties

Flotec® PROFESSIONAL

We've taken the best of what contractors have asked for and developed an elite group of products that meet and exceed the requirements of any professional installer. Flotec® Professional pumps are exactly what professional contractors demand!

PARTS₂O™ Accessories

For a complete line of sump pump accessories see page 20.



Non-Submersible Pedestal Sump Pumps

Thermoplastic or Cast Iron/Stainless Steel

Rugged Construction

Designed for a high level of corrosion resistance

Durable Motor

Thermal overload protection



1/3 HP 3480 GPH
FPPM3600D

1/3 HP 3480 GPH
FPPSS3000

PERFORMANCE (GPH)						FLOAT SWITCH		SOLIDS HANDLING
DISCHARGE HEIGHT ABOVE PUMPING LEVEL	0'	5'	10'	15'	MAX. LIFT	ON	OFF	
FPPM3600D	3480	3000	2460	1620	20'	14"	6"	1/4"
FPPSS3000	3480	3000	2460	1620	20'	14"	6"	1/4"

MODEL	WARRANTY	UPC	CARTON DIMENSIONS	PALLET QTY.	WEIGHT
FPPM3600D	1 YEAR	022315100084	8.25" x 7.25" x 33.5"	30	12.8 LBS.
FPPSS3000	2 YEAR	022315101999	8.25" x 7.25" x 33.5"	30	17.4 LBS.

Includes:

1-1/4" discharge (FPPM3600D), 1-1/2" discharge (FPPSS3000), 6' grounded power cord

Check valve replacement recommended

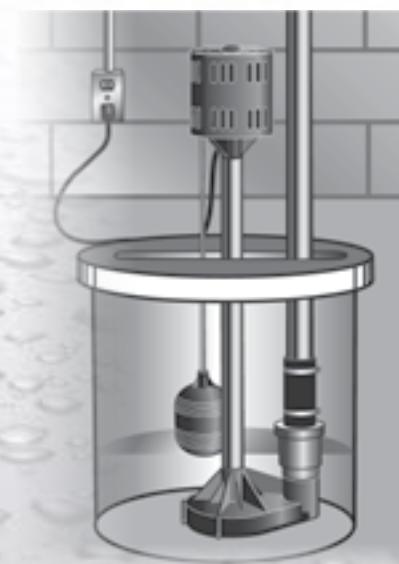

Operates in 12" basins and larger.

Thermoplastic Easy Sump™

High-Output Performance

Pre-Plumbed For Easy Installation

Three easy steps saves time and money

Versatile Design

Replaces pedestal or submersible pump

Thermoplastic Construction

Resists corrosion

Zinc Motor Housing

Dissipates heat quickly and extends motor life

Stainless Steel Fasteners and Hardware

Superior quality

Smooth Flow Hydraulics™

Deliver high performance for demanding applications

Vertical Float Switch

Piggyback plug for easy replacement



Measure & Cut



Remove & Replace



Connect & Tighten



1/2 HP 4200 GPH
FPZS50RP

PERFORMANCE (GPH)							FLOAT SWITCH		SOLIDS HANDLING
DISCHARGE HEIGHT ABOVE PUMPING LEVEL	0'	5'	10'	15'	20'	MAX. LIFT	ON	OFF	
FPZS50RP	4,200	3,660	3,000	2,160	960	22'	7.5"	3"	3/16"

MODEL	WARRANTY	UPC	CARTON DIMENSIONS	PALLET QTY.	WEIGHT
FPZS50RP	1 YEAR	022315377332	8" x 6" x 33.25"	35	12.35 LBS

Includes: 1 1/2" NPT discharge, 8' grounded power cord, piggyback-style switch for automatic or manual operation, check valve, 1-1/2" PVC pipe

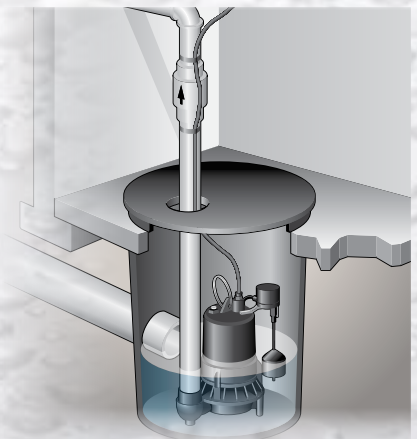

Operates in 10" basins and larger.

Thermoplastic Sump Pump

High-Output Performance



Energy Efficient Design



Thermoplastic Construction

Resists corrosion

Zinc Motor Housing

Dissipates heat quickly and extends motor life

Stainless Steel Fasteners and Hardware

Superior quality

Smooth Flow Hydraulics™

Deliver high performance for demanding applications

Tethered Float Switch

Piggyback plug for easy replacement

1/4 HP 3200 GPH
FPZS25T

1/3 HP 3600 GPH
FPZS33T

1/2 HP 4200 GPH
FPZS50T

PERFORMANCE (GPH)							FLOAT SWITCH		SOLIDS HANDLING
DISCHARGE HEIGHT ABOVE PUMPING LEVEL	0'	5'	10'	15'	20'	MAX. LIFT	ON	OFF	
FPZS25T	3,200	2,700	2,160	1,500	-	20'	14"	5"	3/16"
FPZS33T	3,600	3,060	2,400	1,680	660	22'	14"	5"	3/16"
FPZS50T	4,200	3,660	3,000	2,160	960	22'	14"	5"	3/16"

MODEL	WARRANTY	UPC	CARTON DIMENSIONS	PALLET QTY.	WEIGHT
FPZS25T	1 YEAR	022315368453	8" x 6" x 12.75"	105	7.7 LBS.
FPZS33T	1 YEAR	022315368460	8" x 6" x 12.75"	105	7.7 LBS
FPZS50T	1 YEAR	022315368484	8" x 6" x 12.75"	105	10 LBS

Includes: 1 1/2" NPT discharge, 8' grounded power cord, piggyback-style switch for automatic or manual operation

Check Valve replacement is recommended

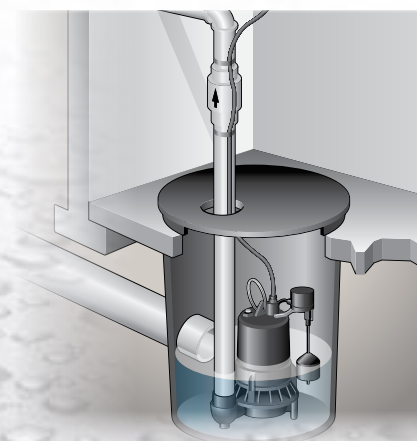

Operates in 14" basins and larger.



Energy Efficient Design

Thermoplastic Sump Pump

High-Output Performance

Thermoplastic Construction

Resists corrosion

Zinc Motor Housing

Dissipates heat quickly and extends motor life

Stainless Steel Fasteners and Hardware

Superior quality

Smooth Flow Hydraulics™

Deliver high performance for demanding applications

Vertical Float Switch

Piggyback plug for easy replacement



1/3 HP 3600 GPH
FPZS33V

1/2 HP 4200 GPH
FPZS50V

3/4 HP 4700 GPH
FPZS75V

PERFORMANCE (GPH)							FLOAT SWITCH		SOLIDS HANDLING
DISCHARGE HEIGHT ABOVE PUMPING LEVEL	0'	5'	10'	15'	20'	MAX. LIFT	ON	OFF	
FPZS33V	3,600	3,060	2,400	1,680	660	22'	7.5"	3"	3/16"
FPZS50V	4,200	3,660	3,000	2,160	960	22'	7.5"	3"	3/16"
FPZS75V	4,700	4,200	3,540	2,820	1,800	24'	7.5"	3"	3/16"

MODEL	WARRANTY	UPC	CARTON DIMENSIONS	PALLET QTY.	WEIGHT
FPZS33V	1 YEAR	022315368477	8" x 6" x 12.75"	105	7.7 LBS.
FPZS50V	1 YEAR	022315368491	8" x 6" x 12.75"	105	10 LBS
FPZS75V	1 YEAR	022315368507	8" x 6" x 12.75"	105	10 LBS

Includes: 1 1/2" NPT discharge, 8' grounded power cord, piggyback-style switch for automatic or manual operation

Check Valve replacement is recommended

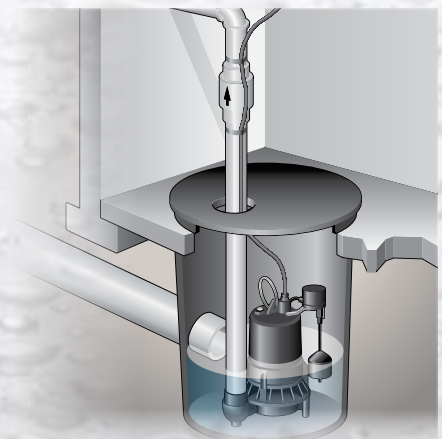

Operates in 10" basins and larger.



Energy Efficient Design

Cast Iron/Zinc Sump Pump



Cast Iron Base

Provides strength and durability

Corrosion Resistant Zinc Body

Dissipates heat quickly and extends motor life

Energy Efficient Motor

Saves operating costs

Stainless Steel Fasteners and Hardware

Superior quality

Smooth Flow Hydraulics™

Delivers high performance for demanding applications

Vertical Float Switch

Piggyback plug for easy replacement

1/3 HP 4200 GPH
FPCI3350

1/2 HP 4700 GPH
FPCI5050

PERFORMANCE (GPH)							FLOAT SWITCH		SOLIDS HANDLING
DISCHARGE HEIGHT ABOVE PUMPING LEVEL	0'	5'	10'	15'	20'	MAX. LIFT	ON	OFF	
FPCI3350	4,200	3,660	3,000	2,160	960	22	7.5"	3"	1/4"
FPCI5050	4,700	4,200	3,540	2,820	1,800	24'	7.5"	3"	1/4"

MODEL	WARRANTY	UPC	CARTON DIMENSIONS	PALLET QTY.	WEIGHT
FPCI3350	2 YEAR	022315378186	7.63" x 7.63" x 14.25"	90	14.6 LBS
FPCI5050	2 YEAR	022315368439	7.63" x 7.63" x 14.25"	90	14.6 LBS.

Includes: 1 1/2" NPT discharge, 8' grounded power cord, piggyback-style switch for automatic or manual operation

Check Valve replacement is recommended

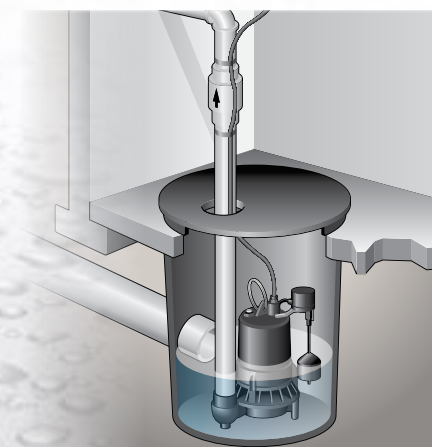

Operates in 10" basins and larger.

Zinc Sump Pump

High-Output Performance

Corrosion Resistant Zinc Construction

Dissipates heat quickly and extends motor life

Uni-Body Motor Housing

Eliminates leak points and maximizes pump life

Stainless Steel Fasteners and Hardware

Superior quality

Quadra Seal™ Technology

Provides superior motor protection over single seal designs

Smooth Flow Hydraulics™

Deliver high performance for demanding applications

Tethered Float Switch

Piggyback plug for easy replacement



1/2 HP 6000 GPH
FPZT7300

PERFORMANCE (GPH)							FLOAT SWITCH		SOLIDS HANDLING
DISCHARGE HEIGHT ABOVE PUMPING LEVEL	0'	5'	10'	15'	20'	MAX. LIFT	ON	OFF	
FPZT7300	6000	5,100	4,140	2,940	1,380	23'	13.5"	4.5"	3/8"

MODEL	WARRANTY	UPC	CARTON DIMENSIONS	PALLET QTY.	WEIGHT
FPZT7300	3 YEAR	022315367982	10" x 8" x 13.5"	60	15 LBS.

Includes: 1 1/2" NPT discharge, 8' grounded power cord, piggyback-style switch for automatic or manual operation

Check Valve replacement is recommended

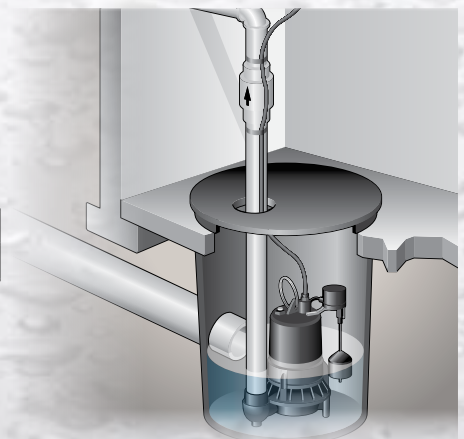

Operates in 14" basins and larger.

Zinc Sump Pump

High-Output Performance

Corrosion Resistant Zinc Construction

Dissipates heat quickly and extends motor life

Uni-Body Motor Housing

Eliminates leak points and maximizes pump life

Stainless Steel Fasteners and Hardware

Superior quality

Quadra Seal™ Technology

Provides superior motor protection over single seal designs

Smooth Flow Hydraulics™

Deliver high performance for demanding applications

Vertical Float Switch

Piggyback plug for easy replacement



1/2 HP 6000 GPH
FPZT7350

3/4 HP 6360 GPH
FPZT7450

1 HP 6660 GPH
FPZT7550

PERFORMANCE (GPH)								FLOAT SWITCH		SOLIDS HANDLING
DISCHARGE HEIGHT ABOVE PUMPING LEVEL	0'	5'	10'	15'	20'	25'	MAX. LIFT	ON	OFF	
FPZT7350	6000	5,100	4,140	2,940	1,380	-	23'	7.5"	3"	3/8"
FPZT7450	6,360	5,460	4,500	3,420	2,100	420	26'	7.5"	3"	3/8"
FPZT7550	6,660	5,880	4,980	4,020	2,880	1,500	29'	7.5"	3"	3/8"

MODEL	WARRANTY	UPC	CARTON DIMENSIONS	PALLET QTY.	WEIGHT
FPZT7350	3 YEAR	022315368118	10" x 8" x 13.5"	60	15 LBS.
FPZT7450	3 YEAR	022315368002	10" x 8" x 13.5"	60	15 LBS
FPZT7550	3 YEAR	022315368309	10" x 8" x 13.5"	60	15 LBS

Includes: 1 1/2" NPT discharge, 8' grounded power cord, piggyback-style switch for automatic or manual operation

Check Valve replacement is recommended

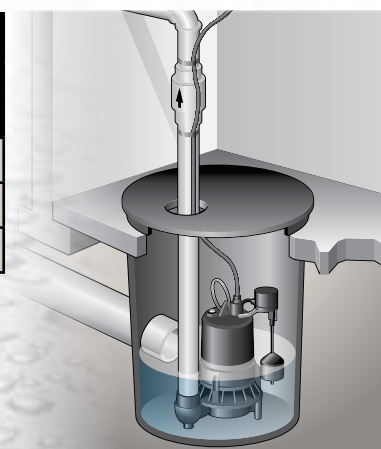

Operates in 11" basins and larger.

Cast Iron Sump Pump

Sump Pump with Vertical Switch

Rugged Cast Iron Construction

Designed for years of trouble-free operation

Recessed Vortex Impeller

Resists clogging

Heavy-Duty Integrated Vertical Switch

Great For Laundry Applications

Passes up to 1/2" solids. 1-1/2" NPT discharge



Contractor-Preferred Switch

1/3 HP 3360 GPH
FPSC3350A

PERFORMANCE (GPH)							FLOAT SWITCH		SOLIDS HANDLING
DISCHARGE HEIGHT ABOVE PUMPING LEVEL	0'	5'	10'	15'	20'	MAX. LIFT	ON	OFF	
FPSC3350A	3360	2880	2400	1740	900	24'	9"	4"	1/2"

MODEL	WARRANTY	UPC	CARTON DIMENSIONS	PALLET QTY.	WEIGHT
FPSC3350A	3 YEAR	022315358133	12.5" x 9.75" x 13"	42	24 LBS.

Includes:

1-1/2" NPT discharge, grounded 10' power cord

Check valve replacement recommended



Operates in 11" basins and larger.

Cast Iron Sump Pumps

High-Output Professional-Grade
Sump Pumps with Vertical Switch



Vertical Float Switch

Rugged Construction

Energy-Efficient PSC Motor

5-Year Warranty



80 GPM 4,800 GPH

88 GPM 5,280 GPH

MODEL E50VLT

1 / 2 HP

MODEL E75VLT

3 / 4 HP

PERFORMANCE (GPM/GPH)	DISCHARGE HEIGHT ABOVE PUMPING LEVEL						FLOAT SWITCH		SOLIDS HANDLING
	0'	5'	10'	15'	20'	MAX. LIFT	ON	OFF	
E50VLT	80 4800	72 4320	61 3660	44 2640	17 1020	22'	7.5"	3"	3/8"
E75VLT	88 5280	80 4800	67 4020	53 3180	30 1800	25'	7.5"	3"	3/8"

MODEL	UPC	CARTON DIMENSIONS	PALLET QTY.	WEIGHT
E50VLT	022315345799	12.37" x 10.38" x 15.4"	36	25.5 lbs.
E75VLT	022315342782	12.37" x 10.38" x 15.4"	36	25.5 lbs.

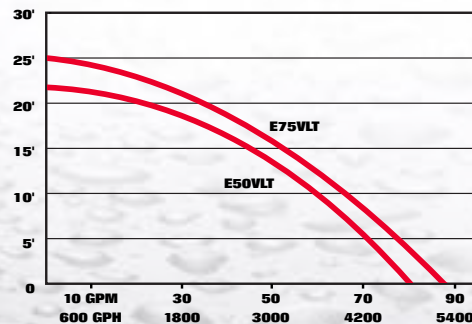

Operates in 10" basins and larger.

Includes:

Piggyback-style switch for automatic or manual operation

Check valve replacement recommended

115V AC 1 Phase

10' Power Cord

1.5" FNPT Discharge

Emergency Battery Backup

Sump Pump System

Basement Flood Protection

Operates automatically during power outage or if primary pump fails.

Proprietary Smart Charging Technology

Recharges battery up to 5X faster and extends battery life.

High Performance Pump

Removes up to 48% more gallons per charge than the leading competitor.

Dual Battery Capacity

Provides extended run time.



12V 2040 GPH
FPDC20

PERFORMANCE (GPH)						SOLIDS HANDLING
DISCHARGE HEIGHT ABOVE PUMPING LEVEL	0'	5'	10'	12'	MAX. LIFT	
FPDC20	2040	1380	600	240	13.3'	3/16"

FEATURE	FLOTEC® FPCC3320	COMPETITION	FLOTEC ADVANTAGE
Max Flow (12.7V)	2040 GPH	1680 GPH	21% more flow
Flow @ 10' (12.7V)	600 GPH	300 GPH	2X more flow
Max Head	13.3'	11.6'	15% higher head
Gallons per charge @ 10' head*	2900	1951	48% more gallons per charge
Charger	2.0 AMPS	0.4 AMPS	5X faster charging

*Performance data based on internal testing using manufacturer's recommended battery

MODEL	WARRANTY	UPC	CARTON DIMENSIONS	PALLET QTY.	WEIGHT
FPDC20	1 YEAR	022315368354	16" x 10" x 20"	24	10.2 LBS.



Includes: battery case control unit, 12V pump, reed switch, AC power supply, 1-1/4" NPT to 1-1/2" glue PVC elbow

Compatible with flooded and sealed AGM deep cycle lead acid batteries.

For best performance use Flotec BAT40 or BAT75 sealed AGM batteries.

Emergency Battery Backup

Pre-Assembled Sump Pump System

Proprietary Smart Charging Technology

Recharges battery 5X faster and extends battery life.

High Performance Pump

Removes up to 48% more gallons per charge than the leading competitor.

1/3 HP Primary Pump

Removes 3600 gallons per hour.



12V 2040 GPH FPCC3320

PERFORMANCE (GPH)							FLOAT SWITCH		SOLIDS HANDLING
DISCHARGE HEIGHT ABOVE PUMPING LEVEL	0'	5'	10'	15'	20'	MAX. LIFT	ON	OFF	
PRIMARY PUMP	3600	3060	2400	1680	660	22'	7.5"	3"	3/16"

DISCHARGE HEIGHT ABOVE PUMPING LEVEL	0'	5'	10'	12'	MAX. LIFT	FLOAT SWITCH		SOLIDS HANDLING
						ON	OFF	
BACKUP PUMP	2040	1380	600	240	13.3'	-	-	3/16"

FEATURE	FLOTEC® FPCC3320	COMPETITION	FLOTEC ADVANTAGE
Max Flow (12.7V)	2040 GPH	1680 GPH	21% more flow
Flow @ 10' (12.7V)	600 GPH	300 GPH	2X more flow
Max Head	13.3'	11.6'	15% higher head
Gallons per charge @ 10' head	2900	1951	48% more gallons per charge
Charger	2.0 AMPS	0.4 AMPS	5X faster charging



Operates in 14" basins and larger.

Includes: Battery case control unit, 12V pump, Reed switch, AC Power supply, Pre-plumbed w/wye connection & check valves, 1/3 HP primary pump - w/vertical switch

Compatible with flooded and sealed AGM deep cycle lead acid batteries.

For best performance use Flotec BAT40 or BAT75 sealed AGM batteries.

*Performance data based on internal testing using manufacturer's recommended battery

MODEL	WARRANTY	UPC	CARTON DIMENSIONS	PALLET QTY.	WEIGHT
FPCC3320	1 YEAR	022315377585	18.25 x 10.13 x 16.63	20	18.5 LBS.

Emergency Battery Backup Sump Pump System

Sump Pump System

Virtual Water Assistant® Remote Monitoring

Constantly monitors system conditions, and alerts you (by cellphone or computer) when your basement is in danger of flooding. At home, at work, or across the globe – you are protected and informed.

Proprietary Smart Charging Technology

Recharges battery 25% faster and extends battery life.

High Performance Pump

Removes up to 83% more gallons per charge than the leading competitor.



LEARN MORE AT :
www.mylink2o.com



12V 3000 GPH
FPDC30

PERFORMANCE (GPH)						SOLIDS HANDLING
DISCHARGE HEIGHT ABOVE PUMPING LEVEL	0'	5'	10'	14'	MAX. LIFT	
FPDC30	2700	2040	1260	360	15'	3/16"

FEATURE	FLOTEC® FPDC30	COMPETITION	FLOTEC ADVANTAGE
Max Flow (12.7V)	2700	2200	22% more flow
Flow @ 10' (12.7V)	1260	900	40% more flow
Max Head	15'	14'	7% higher head
Gallons per charge @ 10' head	11,500	6300	83% more gallons per charge
Charger	2.0 AMPS	1.6 AMPS	25% faster charging

*Performance data based on internal testing using BAT75

MODEL	WARRANTY	UPC	CARTON DIMENSIONS	PALLET QTY.	WEIGHT
FPDC30	2 YEAR	022315368385	18.25 x 10.13 x 16.63	20	12.2 LBS.



Includes: battery case control unit, 12V pump, reed switch, AC power supply, wireless gateway, 1-1/4" NPT to 1-1/2" glue PVC elbow

Compatible with flooded and sealed AGM deep cycle lead acid batteries.

For best performance use Flotec BAT40 or BAT75 sealed AGM batteries.

Emergency Battery Backup

Pre-Assembled Sump Pump System

Virtual Water Assistant® Remote Monitoring

Constantly monitors system conditions, and alerts you (by cellphone or computer) when your basement is in danger of flooding. At home, at work, or across the globe – you are protected and informed.

Proprietary Smart Charging Technology

Recharges battery 25% faster and extends battery life.

High Performance Pump

Removes up to 83% more gallons per charge than the leading competitor.

1/2 HP Primary Pump

Removes 4200 gallons per hour.



LEARN MORE AT : www.mylink2o.com

12V 4200 GPH FPCC5030

PERFORMANCE (GPH)							FLOAT SWITCH		SOLIDS HANDLING
	DISCHARGE HEIGHT ABOVE PUMPING LEVEL	0'	5'	10'	15'	20'	MAX. LIFT	ON	
PRIMARY PUMP	4200	3660	3000	2160	960	22'	7.5"	3"	3/16"

DISCHARGE HEIGHT ABOVE PUMPING LEVEL	0'	5'	10'	14'	MAX. LIFT	FLOAT SWITCH		SOLIDS HANDLING
						ON	OFF	
BACKUP PUMP	2700	2040	1260	360	15'	-	-	3/16"

FEATURE	FLOTEC® FPCC5030	COMPETITION	FLOTEC ADVANTAGE
Max Flow (12.7V)	2700	2200	22% more flow
Flow @ 10' (12.7V)	1260	900	40% more flow
Max Head	15'	14'	7% higher head
Gallons per charge @ 10' head	11,500	6300	83% more gallons per charge
Charger	2.0 AMPS	1.6 AMPS	25% faster charging

*Performance data based on internal testing using BAT75

MODEL	WARRANTY	UPC	CARTON DIMENSIONS	PALLET QTY.	WEIGHT
FPCC5030	2 YEAR	022315377592	18.25 x 10.13 x 16.63	20	22.0 LBS.



Operates in 14" basins and larger.

Includes: Battery case control unit, 12V pump, Reed switch, AC Power supply, Wireless gateway, Pre-plumbed w/wye connection & check valves, 1/2 HP primary pump - w/vertical switch

Compatible with flooded and sealed AGM deep cycle lead acid batteries.

For best performance use Flotec BAT40 or BAT75 sealed AGM batteries.

Self-Contained Sink Pump System

With 1/3 HP Sump Pump

Under-Sink Basin System

Ideal for pumping washing machine, wet bar and air conditioning drainage without an in-ground basin

Heavy-Duty

6-gallon structural foam drainage tank

Easy Installation

Eliminates need for expensive plumbing renovation



1/3 HP 2880 GPH
FPZS33LTS

PERFORMANCE (GPH)							FLOAT SWITCH		SOLIDS HANDLING
DISCHARGE HEIGHT ABOVE PUMPING LEVEL	0'	5'	10'	15'	20'	MAX. LIFT	ON	OFF	
FPZS33LTS	3600	3060	2400	1680	660	22'	7.5"	3"	3/16"

MODEL	WARRANTY	UPC	CARTON DIMENSIONS	PALLET QTY.	WEIGHT
FPZS33LTS	1 YEAR	022315377981	15.2" x 15.8" x 14.2"	18	18 LBS.

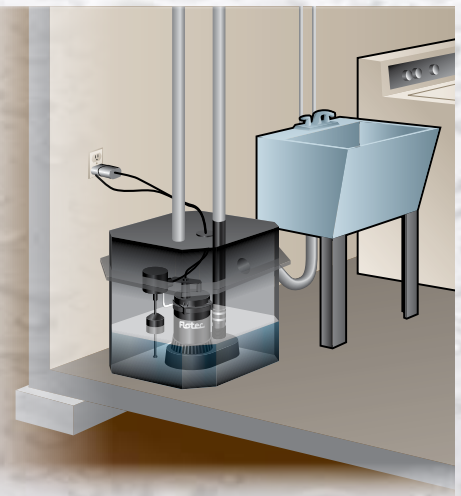

Includes: Check valve, 1-1/2" x 6-3/4" discharge pipe, basin, 1/3 HP sump pump, 8' grounded power cord

All pipes taps in the basin (inlet, discharge, vent) are 1.5" NPT female.

Under-Sink Mounted Utility Sink Pump

Complete, Compact System

Perfect for basement wet bars, laundry and utility sinks

Easy to Install

Eliminates the need for traps, vents and costly labor

Quiet, Trouble-Free Operation

Easily mounts beneath your sink



1/3 HP 1860 GPH
FPUS1860A

PERFORMANCE (GPH)						SOLIDS HANDLING
DISCHARGE HEIGHT ABOVE PUMPING LEVEL	0'	4'	8'	12'	MAX. LIFT	
FPUS1860A	2400	2040	1320	240	14'	1/8"

MODEL	WARRANTY	UPC	CARTON DIMENSIONS	PALLET QTY.	WEIGHT
FPUS1860A	1 YEAR	022315327092	10.4" x 9.4" x 13.6"	60	15.3 LBS.



Includes: 1-1/4" check valve, 1-1/4" ball valve, sink drain screen, O-ring and gasket seal, 8' grounded power cord

1-1/4" Suction and discharge

Sump Pump Accessories

Universal Hose Kit	FP0012-6U-P2
Universal Hose Kit Adapter	FP125A-P2-P2*

Check Valves

Threaded 1-1/4" or 1-1/2"	FP0026-6D-P2
In-Line 1-1/4" or 1-1/2"	FP0026-10-P2

Float Switches

Tethered	FP18-15BD-P2
Vertical	FPS17- 66-P2
Direct-Connect	FPFS-P2
Pedestal	FP0018-7D-P2

18" Sump Basin	FPW73-19-P2
18" Sump Basin Lid	FPW73-20-P2
18" Gas Tight Sump/Sewage Basin Lid	FPW73-25-P2*

12V Batteries

40 AH Sealed AGM	BAT40
75 AH Sealed AGM	BAT75
100 AH Sealed AGM	BAT100

*Not shown



FP0012-6U-P2



FP0026-6D-P2

FP0026-10-P2



FP18-15BD-P2



FPFS-P2

FPS17-66-P2



FP0018-7D-P2



FPW73-19-P2

FPW73-20-P2



BAT40
BAT75
BAT100



Effluent Pumps

An effluent pump is used to transfer liquid effluent "grey water" from a pumping chamber to a distribution component when the effluent cannot flow by gravity. Liquid effluent is what is ejected from dishwashers, washing machines, shower stalls and bath tubs. These pumps are not equipped to handle flushable waste, such as sewage.

Product Line Overview

1/3 HP to 1/2 HP ranges

Cast Iron and Thermoplastic Construction available

Handles up to 3/4" solids

Rated to handle up to 130°F

Self-contained Sewage System available

1-year to 5-year warranties

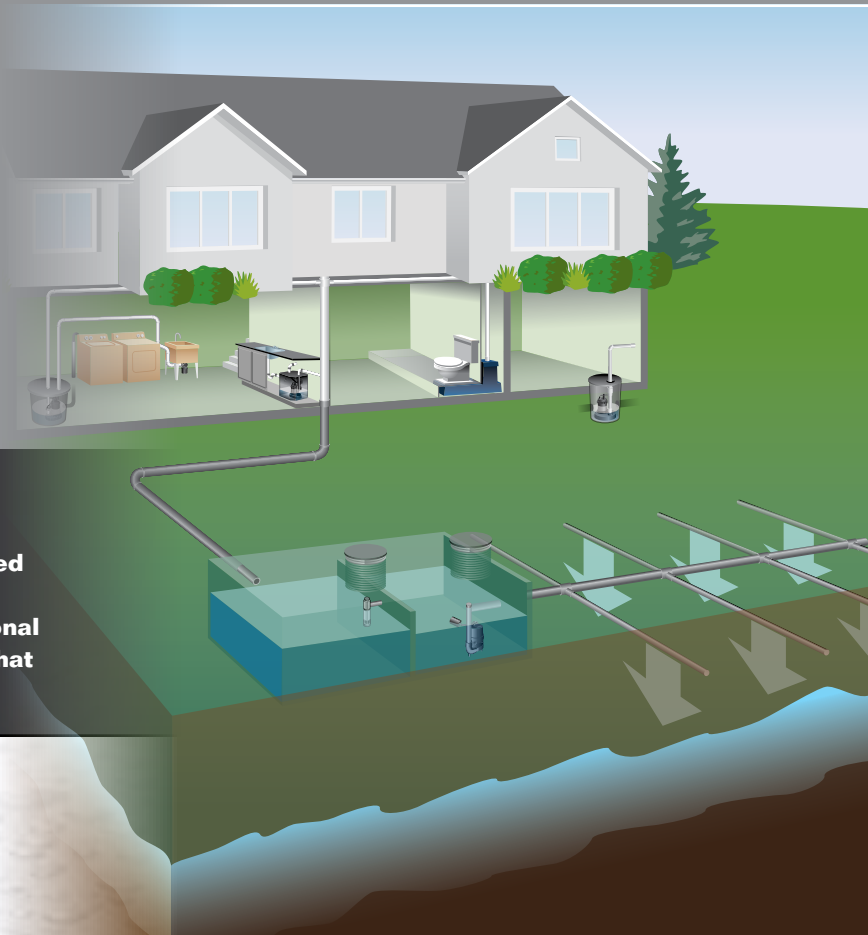

Flotec® PROFESSIONAL

We've taken the best of what contractors have asked for and developed an elite group of products that meet and exceed the requirements of any professional installer. Flotec® Professional pumps are exactly what professional contractors demand!

PARTS₂O™ Accessories

For a complete line of effluent and sewage pump accessories see page 31.

Thermoplastic Effluent Pump

With Tethered Switch

Handles up to 3/4" Solids

Virtually clog-free discharge

Thermoplastic Construction

For corrosion resistance

High-Efficiency Motor

With overload protection

Tethered Float Switch

Piggyback controls allow for manual operation



1/3 HP 3600 GPH
FPSE2800A

PERFORMANCE (GPH)								FLOAT SWITCH		SOLIDS HANDLING
DISCHARGE HEIGHT ABOVE PUMPING LEVEL	0'	5'	10'	15'	20'	25'	MAX. LIFT	ON	OFF	
FPSE2800A	3600	3180	2700	2100	1500	750	29'	14.75"	7.5"	3/4"

MODEL	WARRANTY	UPC	CARTON DIMENSIONS	PALLET QTY.	WEIGHT
FPSE2800A	1 YEAR	022315102026	10.25" x 7.25" x 16.5"	50	12.9 LBS.

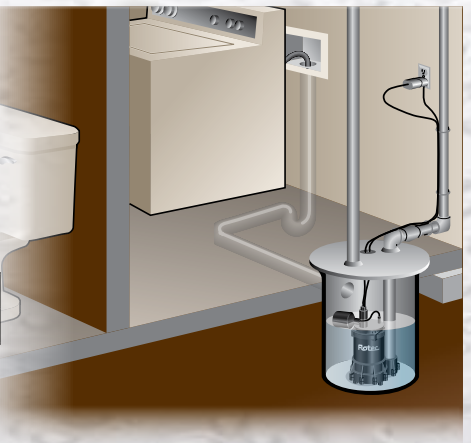

Includes:

2" discharge (meets standard code approvals),
15' power cord for easy installation

Check valve replacement recommended

Operates in 18" basins and larger.

Cast Iron Effluent Pump

With Tethered Switch



Heavy-Duty Motor

Rugged Construction

Handles Up To 3/4" Solids

Easy To Install

Septic Tank, Laundry, and Dishwasher Applications

5-Year Warranty



68 GPM 4,080 GPH

MODEL E3375TLT **1/3 HP**

PERFORMANCE (GPM/GPH)							FLOAT SWITCH		SOLIDS HANDLING
DISCHARGE HEIGHT ABOVE PUMPING LEVEL	0'	5'	10'	15'	20'	MAX. LIFT	ON	OFF	
E3375TLT	68 4080	58 3480	46 2760	32 1920	12 720	22'	13.5"	4.5"	3/4"

MODEL	UPC	CARTON DIMENSIONS	PALLET QTY.	WEIGHT
E3375TLT	022315363632	12.75" x 10" x 12.88"	42	28 lbs.

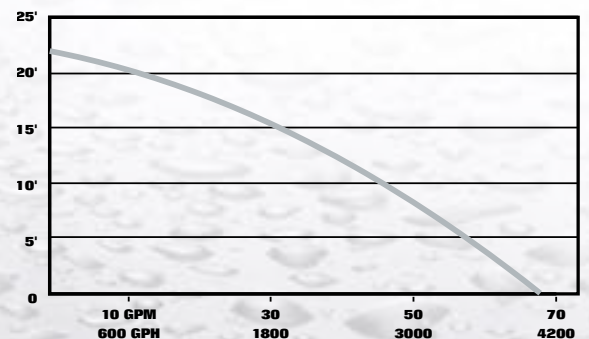

Operates in 14" basins and larger.

Check valve replacement recommended

115V AC 1 Phase

20' Power Cord

1.5" FNPT Discharge

Cast Iron Effluent Pump

With Tethered Switch



Heavy-Duty Motor

Rugged Construction

Handles Up To 1/2" Solids

Easy To Install

**Septic Tank, Laundry,
and Dishwasher Applications**

5-Year Warranty



56 GPM 3,360 GPH
67 GPM 4,020 GPH

MODEL E3305TLT

1/3 HP

MODEL E5005TLT

1/2 HP

PERFORMANCE (GPM/GPH)									FLOAT SWITCH	
DISCHARGE HEIGHT ABOVE PUMPING LEVEL	0'	5'	10'	15'	20'	25'	30'	MAX. LIFT	ON	OFF
E3305TLT	56 3360	48 2880	40 2400	29 1740	15 90	—	—	24'	13"	4"
E5005TLT	67 4020	62 3720	53 3180	46 2760	38 2280	29 1740	13 780	32'	13"	4"

MODEL	UPC	CARTON DIMENSIONS	PALLET QTY.	WEIGHT
E3305TLT	022315363625	12.75" x 10" x 12.88"	42	25 lbs.
E5005TLT	022315363649	12.75" x 10" x 12.88"	42	33 lbs.

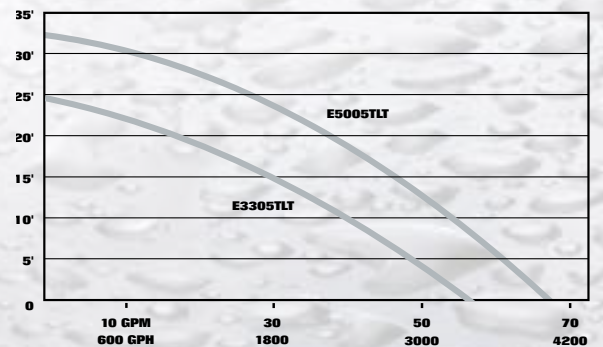

Operates in 14" basins and larger.

Check valve replacement recommended

115V AC 1 Phase

20' Power Cord

1.5" FNPT Discharge



Sewage Pumps

A necessity for homes with basement toilets or washing machines, sewage/effluent pumps lift waste water from the sewage basin up and into the main sewer line. The built-in impeller creates a spinning action in the water to keep solids up to 2" in diameter moving freely.

Product Line Overview

4/10 HP to 3/4 HP ranges

Stainless Steel and Cast Iron or Thermoplastic Construction

Handles solids up to 2" in diameter

All-in-one Sewage Pump System available

Self-contained Sewage System available

1-year to 5-year warranties

Flotec® PROFESSIONAL

We've taken the best of what contractors have asked for and developed an elite group of products that meet and exceed the requirements of any professional installer. Flotec® Professional pumps are exactly what professional contractors demand!

PARTS₂O™ Accessories

For a complete line of effluent and sewage pump accessories see page 31.



Thermoplastic Sewage Pump

With Tethered Switch

Handles up to 2" Solids

Virtually clog-free discharge

Thermoplastic Construction

For corrosion resistance

High-Efficiency Motor

With overload protection

Tethered Float Switch

Piggyback controls allow for manual operation



4/10 HP 5250 GPH
FPSE3200A

PERFORMANCE (GPH)						FLOAT SWITCH		SOLIDS HANDLING
DISCHARGE HEIGHT ABOVE PUMPING LEVEL	0'	5'	10'	15'	MAX. LIFT	ON	OFF	
FPSE3200A	5250	3900	2550	960	18'	17.25"	9.5"	2"

MODEL	WARRANTY	UPC	CARTON DIMENSIONS	PALLET QTY.	WEIGHT
FPSE3200A	1 YEAR	022315102019	10.25" x 7.25" x 16.5"	50	12 LBS.

Includes:

2" discharge (meets standard code approvals),
8' power cord for easy installation

Check valve replacement recommended



Operates in 18" basins and larger.

Stainless Steel/Thermoplastic Sewage Pump

With Tethered Switch

High-Output Performance

High-efficiency PSC technology
saves operating costs

Rugged Stainless Steel Construction

Corrosion-resistant for
heavy-duty applications

Virtually Clog-Free Discharge

Handles up to 2" solids

Tethered Float Switch

Piggyback controls allow for manual operation



1/2 HP 9000 GPH
FPSE9000

PERFORMANCE (GPH)							FLOAT SWITCH		SOLIDS HANDLING
DISCHARGE HEIGHT ABOVE PUMPING LEVEL	0'	5'	10'	15'	20'	MAX. LIFT	ON	OFF	
FPSE9000	9000	8400	6720	4200	1020	22'	14"	5.5"	2"

MODEL	WARRANTY	UPC	CARTON DIMENSIONS	PALLET QTY.	WEIGHT
FPSE9000	5 YEAR	022315342132	12.2" x 10.6" x 17.4"	24	20.1 LBS.

Includes:

2" discharge (meets standard code approvals),
10' power cord for easy installation

Check valve replacement recommended



Operates in 18" basins and larger.

Cast Iron Sewage Pump

With Tethered Switch

High-Output Performance

Pumps up to 9000 gallons per hour

Rugged Cast Iron Construction

For heavy-duty applications

Clog-Free Discharge

Handles up to 2" solids

Tethered Float Switch

Piggyback controls allow for manual operation



1/2 HP 9000 GPH
FPSE3601A

PERFORMANCE (GPH)						FLOAT SWITCH		SOLIDS HANDLING
DISCHARGE HEIGHT ABOVE PUMPING LEVEL	0'	5'	10'	15'	MAX. LIFT	ON	OFF	
FPSE3601A	9000	7320	5400	2700	18'	16.5"	7.5"	2"

MODEL	WARRANTY	UPC	CARTON DIMENSIONS	PALLET QTY.	WEIGHT
FPSE3601A	3 YEAR	022315100350	10.56" x 9.19" x 17.06"	32	36.3 LBS.

Includes:

2" discharge (meets standard code approvals),
10' power cord for easy installation,

Check valve replacement recommended



Operates in 18" basins and larger.

Cast Iron Sewage Pump

With Tethered Switch



Rugged Construction

High-Efficiency PSC Motor

Handles Up To 2" Solids

5-Year Warranty



225 GPM 13,500 GPH

MODEL E75STVT

3/4 HP

PERFORMANCE (GPM/GPH)							FLOAT SWITCH		SOLIDS HANDLING
DISCHARGE HEIGHT ABOVE PUMPING LEVEL	0'	5'	10'	15'	20'	MAX. LIFT	ON	OFF	
E75STVT	225 13,500	190 11,400	153 9,180	105 6,300	40 2,400	22'	16.5"	7.5"	2"

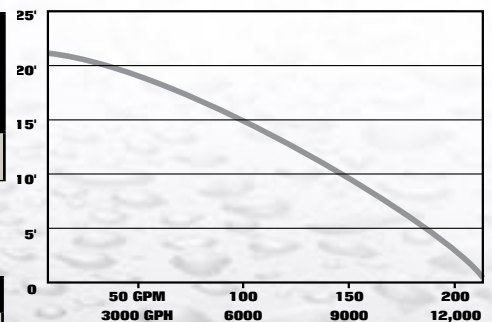

MODEL	UPC	CARTON DIMENSIONS	PALLET QTY.	WEIGHT
E75STVT	022315342187	11.4" x 10.4" x 16.4"	32	50.5 lbs.

Operates in 18" basins and larger.

Check valve replacement recommended

115V AC 1 Phase

10' Power Cord

2" FNPT Discharge

Complete Sewage Pump System

With 4/10 HP Sewage Pump

All-in-One System

Includes basin, lid cover, check valve and pump

Virtually Clog-Free Discharge

Handles up to 2" solids

Thermoplastic Construction

For corrosion resistance



4/10 HP 5250 GPH
FP400C

PERFORMANCE (GPH)						FLOAT SWITCH		SOLIDS HANDLING
DISCHARGE HEIGHT ABOVE PUMPING LEVEL	0'	5'	10'	15'	MAX. LIFT	ON	OFF	
FP400C	5250	3900	2550	960	18'	17.25"	9.5"	2"

MODEL	WARRANTY	UPC	CARTON DIMENSIONS	PALLET QTY.	WEIGHT
FP400C	1 YEAR	022315137271	18" x 30" x 18"	4	29.75 LBS.



Includes:

2" discharge (meets standard code approvals), 8' power cord, and check valve.



Effluent and Sewage Pump Accessories

2" in-line heavy-duty check valve	FPW212-4-P2
2" in-line check valve	FP212-257-P2
18" Sewage Basin	FPW73-15-P2
18" Sewage Basin Lid	FPW73-17-P2
18" Gas Tight Sump/ Sewage Basin Lid	FPW73-25-P2*

*Not shown



FP212-257-P2



FPW73-15-P2

FPW73-17-P2



FPW212-4-P2

Flotec®

Utility Pumps

In an emergency, a utility pump is the pump you need to have on hand. Perfect for removing water from window wells, rooftops, flooded areas or for draining sinks, aquariums and water beds. Utility pumps excel at moving water quickly and efficiently from place to place.

Product Line Overview

1/6 HP to 6-1/2 HP ranges

Cast Aluminum, Stainless Steel and Thermoplastic Construction

Submersible and non-submersible products

Portable transfer products

Garden waterfall pumps

Gas engine pumps



PARTS₂O™ Accessories

For a complete line of utility pump accessories see page 46.

Thermoplastic Utility Pump

Submersible

General Purpose Pump

For removing unwanted water to 3/16" depth

Thermoplastic Construction

For the highest corrosion-resistance

Portable and Versatile

Use where unwanted water collects

8' Power Cord Included



1/6 HP 1200 GPH
FP0S1250X

PERFORMANCE (GPH)						DRAWDOWN	DISCHARGE SIZE	HP
DISCHARGE HEIGHT ABOVE PUMPING LEVEL	0'	5'	10'	15'	MAX. LIFT			
FP0S1250X	1200	1140	840	480	20'	3/16"	1"	1/6

MODEL	WARRANTY	UPC	CARTON DIMENSIONS	PALLET QTY.	WEIGHT
FP0S1250X	1 YEAR	022315100015	6.5" x 6.5" x 10.25"	168	5.9 LBS.

Includes: 8' power cord, garden hose adapter



Cast Aluminum Utility Pump

Submersible

Heavy-Duty Construction

Epoxy-coated, cast aluminum housing

Extra-Large 1-1/4" Discharge

Easy, Portable Operation

Attach 5/8" garden hose then just plug in.

Multi-Purpose Pump

For basements, rooftops, window wells or any flooded area



1/4 HP 1320 GPH
FPSC1725X

PERFORMANCE (GPH)							DRAWDOWN	DISCHARGE SIZE	HP
DISCHARGE HEIGHT ABOVE PUMPING LEVEL	0'	5'	10'	15'	20'	MAX. LIFT			
FPSC1725X	1320	1170	1020	810	510	25'	1/8"	1-1/4"	1/4

MODEL	WARRANTY	UPC	CARTON DIMENSIONS	PALLET QTY.	WEIGHT
FPSC1725X	3 YEAR	022315171855	7" x 7" x 10"	90	9.5 LBS.

Includes: 8' power cord, garden hose adapter



Thermoplastic Utility Pumps

Submersible

General Purpose Pump

For removing unwanted water down to 3/16" depth

Thermoplastic Construction

For the highest corrosion-resistance

Portable and Versatile

Use in window wells, basements, rooftops, etc.

Removable Inlet Screen

For easy cleaning



1/6 HP 1470 GPH
FP0S1300X

1/4 HP 1800 GPH
FP0S1600X

PERFORMANCE (GPH)							DRAWDOWN	DISCHARGE SIZE	HP
DISCHARGE HEIGHT ABOVE PUMPING LEVEL	0'	5'	10'	15'	20'	MAX. LIFT			
FP0S1300X	1470	1250	930	660	-	20'	3/16"	1"	1/6
FP0S1600X	1800	1524	1260	924	372	22'	3/16"	1"	1/4

MODEL	WARRANTY	UPC	CARTON DIMENSIONS	PALLET QTY.	WEIGHT
FP0S1300X	1 YEAR	022315100022	6.5" x 6.5" x 9.88"	168	6.4 LBS.
FP0S1600X	1 YEAR	022315138230	6.5" x 6.5" x 9.88"	168	7.4 LBS.

Includes: 8' power cord, garden hose adapter



Thermoplastic Utility Pump

IntelliPump
series

Automatic Operation

Automatically Checks for Water

Detects water at 3/4" and pumps down to 1/4"

Innovative Electronic Monitoring

Pump starts every 2-1/2 minutes to check for water.
Shuts off if water is not detected

Easy, Portable Operation

Attach 5/8" garden hose then just plug in.

Wide Range of Applications

For basements, rooftops, window wells or any regularly flooded area



Water Sensor

Automatically Checks for Water

1/4 HP 1800 GPH
FP0S1775A

PERFORMANCE (GPH)							DRAWDOWN	DISCHARGE SIZE	HP
DISCHARGE HEIGHT ABOVE PUMPING LEVEL	0'	5'	10'	15'	20'	MAX. LIFT			
FP0S1775A	1800	1524	1260	924	372	22'	3/16"	1"	1/4



MODEL	WARRANTY	UPC	CARTON DIMENSIONS	PALLET QTY.	WEIGHT
FP0S1775A	2 YEAR	022315170315	8.31" x 6.25" x 12.13"	108	8.25 LBS.

Includes: 15' power cord, garden hose adapter

Utility Pumps

Submersible

General Purpose Pump

For removing unwanted water down to 3/16" depth

Thermoplastic Construction

Resists corrosion

Zinc Motor Housing

Dissipates heat quickly and extends motor life

Stainless Steel Fasteners and Hardware

Superior quality



1 / 4 HP 2200 GPH FP0S2600X

PERFORMANCE (GPH)							DRAWDOWN	DISCHARGE SIZE	HP
DISCHARGE HEIGHT ABOVE PUMPING LEVEL	0'	5'	10'	15'	20'	MAX. LIFT			
FP0S2600X	2,200	1,890	1,530	1,080	480	22'	3/16"	1"	1/4"

MODEL	WARRANTY	UPC	CARTON DIMENSIONS	PALLET QTY.	WEIGHT
FP0S2600X	1 YEAR	022315378131	6.5 x 6.5 x 10.25	168	5.9 LBS.

Includes: 8' power cord, garden hose adapter

All-in-One Pump Kit

Stow & Flo™

Easy to use, easy to store

Includes convenient storage crate

A must-have for emergency situations

Save time and money when unexpected flooding happens

Perfect tool for everyday draining tasks

Great for many uses around your home and garden

Durable crate filters large debris

Versatile kit for large or small jobs



* Compared to average 1/2" garden hose

Save Time with High Volume Output

	20 x 20 Flooded Basement with 1 ft. of Water	
	STOW & FLO 4 HRS	1/2" Garden Hose 12 HRS
	400 Gallon Hot Tub	
	STOW & FLO 30 MIN	1/2" Garden Hose 90 MIN



1/4 HP 2200 GPH

FP0S2600RP

PERFORMANCE (GPH)							DRAWDOWN	DISCHARGE SIZE	HP
DISCHARGE HEIGHT ABOVE PUMPING LEVEL	0'	5'	10'	15'	20'	MAX. LIFT			
FP0S2600RP	2,200	1,890	1,530	1,080	480	22'	3/16"	1"	1/4

MODEL	WARRANTY	UPC	CARTON DIMENSIONS	PALLET QTY.	WEIGHT
FP0S2600RP	1 YEAR	022315368446	13.125" x 13.125" x 11.2"	36	23 LBS.

Includes: 1/4 HP utility pump, 18' high output discharge hose, storage/filter crate, hose adapter, 8' power cord

Thermoplastic Utility/ Waterfall Pump

Submersible

High-Output Performance

Pumps up to 3000 gallons per hour

Thermoplastic Construction

Designed for years of trouble-free operation

Oil-Free Motor

Safe for fish and plants



4/10 HP 3000 GPH
FP0S3000X

PERFORMANCE (GPH)							DRAWDOWN	DISCHARGE SIZE	HP
DISCHARGE HEIGHT ABOVE PUMPING LEVEL	0'	5'	10'	15'	20'	MAX. LIFT			
FP0S3000X	3000	2500	1900	1320	750	25'	7/16"	1-1/4"	4/10

MODEL	WARRANTY	UPC	CARTON DIMENSIONS	PALLET QTY.	WEIGHT
FP0S3000X	1 YEAR	022315164819	6.7" x 6.7" x 12.2"	90	8.4 LBS.



Includes:

Three discharge fittings: 1/2", 3/4" and 1" barbed hose, 1" reducer, garden hose adapter, 15' power cord

Stainless Steel Utility/ Waterfall Pump

Submersible

Superior Performance

Pumps up to 4100 gallons per hour

Complete Stainless Steel Construction

For superior corrosion-resistance

Oil-Free Motor

Safe for fish and plants

Dual Ball-Bearing Design

Quiet, durable and long-lasting



1/2 HP 4100 GPH
FP0S4100X

PERFORMANCE (GPH)								DRAWDOWN	DISCHARGE SIZE	HP
DISCHARGE HEIGHT ABOVE PUMPING LEVEL	0'	5'	10'	15'	20'	25'	MAX. LIFT			
FP0S4100X	4100	3600	3000	2400	1650	900	30'	1-3/8"	1-1/4"	1/2



MODEL	WARRANTY	UPC	CARTON DIMENSIONS	PALLET QTY.	WEIGHT
FP0S4100X	2 YEAR	022315164826	7" x 6.8" x 14"	48	16.8 LBS.

Includes:

Stainless steel impeller, 15' power cord,
1-1/4" x 1" NPT adapter, garden hose adapter

Transfer Utility Pumps

AC or DC Operation

Multi-Purpose Pumps

For emergency dewatering, waterbeds, clogged sinks, aquariums and boat bottoms

Compact and Portable

Easy setup, easy to use

PUD-L-SCOOP® Attachment

Pumps water down to 1/8"

Corrosion-Resistant

Thermoplastic impeller housing



1/12 HP 115V AC 350 GPH
FP0F360AC

1/12 HP 12V DC 450 GPH
FP0FDC

PERFORMANCE (GPH)								SUCTION SIZE	DISCHARGE SIZE
DISCHARGE HEIGHT ABOVE PUMPING LEVEL	0'	5'	10'	20'	30'	40'	MAXIMUM LIFT		
FP0F360AC	350	330	300	240	145	62	43'	3/4" garden hose	3/4" garden hose
FP0FDC	450	435	390	300	225	130	45'		

MODEL	WARRANTY	UPC	CARTON DIMENSIONS	PALLET QTY.	WEIGHT
FP0F360AC	90 DAY	022315100169	6.5" x 6.5" x 11"	168	6.4 LBS.
FP0FDC	90 DAY	022315357716	6.5" x 6.5" x 11"	168	8.21 LBS.

Includes: 6' hose, PUD-L-SCOOP® suction attachment, FP0F360AC – 6' cord; FP0FDC – 9'5" battery leads



Transfer Utility Pump

Portable

Water Transfer/ Pressure Booster

Use as a water transfer, pressure booster or portable sprinkler pump

Thermoplastic Construction

For the highest corrosion-resistance

Increase Water Pressure

For washing vehicles, equipment, sprinkling and more

Sprinkler Pump Operation

Transfer surface water from natural sources for landscape irrigation



1/2 HP 10.3 GPM
FP5112

PERFORMANCE (GPM)									SUCTION SIZE	DISCHARGE SIZE
DISCHARGE HEIGHT ABOVE PUMPING LEVEL	0'	5'	10'	15'	20'	25'	MAX. LIFT	MAX. PSI		
FP5112	10.3	6.1	5.1	4.2	3.9	3	26'	62	1"	1"



WARRANTY	UPC	CARTON DIMENSIONS	PALLET QTY.	WEIGHT
1 YEAR	022315138315	8.5" x 14.5" x 11.2"	30	16.8 LBS.

Includes: 6' power cord, garden hose adapters, 1" threaded suction and discharge

Heating/Cooling System Condensate Pumps

Ideal for Furnace or Air Conditioner

Automatic, maintenance-free operation

Safety Switch

Provides automatic shutoff

Corrosion-Resistant Construction

Designed for years of trouble-free operation

20' Tubing Kit Included

For quick, easy installation
(FPCP-20ULST only)



2 QT 120 GPH
FPCP-15ULS

2 QT 120 GPH
FPCP-20ULST

PERFORMANCE (GPH)					
DISCHARGE HEIGHT ABOVE PUMPING LEVEL	0'	5'	10'	15'	MAXIMUM LIFT
FPCP-15ULS	120	90	65	0t	15'
FPCP-20ULST					

MODEL	WARRANTY	UPC	CARTON DIMS.	PALLET QTY.	WEIGHT
FPCP-15ULS	1 YEAR	022315164949	10.5" x 5.54" x 5.25"	196	4 LBS.
FPCP-20ULST	2 YEAR	022315164932	10.5" x 8.54" x 5.25"	140	4.9 LBS.

Includes: 6' power cord, (20' 3/8" I.D. tubing with FPCP-20ULST only)



Gas-Powered HydroBlaster®

High-Volume Utility Pump

Typical Application

Excellent for floodwater removal and remote irrigation where water lines and electricity are not available

Easy Portability

Portable unit with rugged carrying handle for water transfer in remote locations

Heavy-Duty Gas Engine Motor

With automatic low-oil safety cutoff, manual throttle choke and engine shutoff controls



6.5 HP 144 GPM
FP5455

PERFORMANCE							SUCTION SIZE	DISCHARGE SIZE
DISTANCE TO PUMP ABOVE WATER	GALLONS PER MINUTE AT DISCHARGE PRESSURE (PSI)					MAX PSI		
	15	25	35	45	50			
0'	-	135	106	72	49	59	2"	2"
5'	144	132	96	63	40	57		
10'	142	124	92	52	35	55		
15'	139	117	84	42	22	52		
20'	136	110	78	36	4	50		
25'	133	103	68	28	-	48		

WARRANTY	UPC	CARTON DIMENSIONS	PALLET QTY.	WEIGHT
1 YEAR	022315313941	21" x 14.5" x 18"	12	48.9 LBS.





Utility Pump Accessories

Drill Pump	FPDMP21SA-P2
Drill Pump & Hose Kit	FPDMP21HC-P2
2" Heavy-Duty Discharge Hose	FP2731-P2
2" Reinforced Suction Hose	FP2735-P2
High-Pressure Hose	FPBPH-P2
High-Pressure Spray Nozzle	FPBPN-P2
Universal Hose Kit	FP0012-6U-P2
Universal Hose Kit Adapter	FP125A-P2*

Garden Hose Adapters

3/4" Male GHT to 1" Male NPT	FP13-43-P2
3/4" Male GHT to 1-1/4" Male NPT	HA5-P2
3/4" Male GHT to 1-1/4" Female NPT	HA6-P2

*Not shown



FPDMP21SA-P2



FPDMP21HC-P2



HA5-P2



FP2735-P2



FP2731-P2



HA6-P2



FPBPH-P2



FPBPN-P2



FP0012-6U-P2

Flotec®

Pool Pumps

Whether you are circulating water for an in-ground or above-ground pool, Flotec has the right product for you. Our corrosion-resistant pool pumps are constructed of rugged, heavy-duty fiberglass-reinforced thermoplastic to stand up to seasonal changes.

Product Line Overview

Thermoplastic Pool Pumps from
1 HP to 1-1/2 HP



Calculate Your Pool Size



$$\begin{array}{l}
 3.14 \\
 \times \text{1/2 Diameter} \\
 \times \text{1/2 Diameter} \\
 \times \text{Average Depth} \\
 \hline
 \times 7.5^* \\
 \hline
 = \text{Total Capacity} \\
 \text{in Gallons}
 \end{array}$$



$$\begin{array}{l}
 \text{Length} \\
 \times \text{Width} \\
 \times \text{Average Depth} \\
 \hline
 = \text{Cubic feet} \\
 \hline
 \times 7.5^* \\
 \hline
 = \text{Total Capacity} \\
 \text{in Gallons}
 \end{array}$$

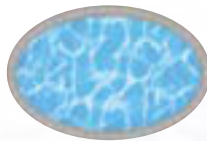

$$\begin{array}{l}
 \text{Length} \\
 \times \text{Width} \\
 \times \text{Average Depth} \\
 \hline
 = \text{Cubic feet} \\
 \hline
 \times 7.5^* \\
 \hline
 = \text{Total Capacity} \\
 \text{in Gallons}
 \end{array}$$

* The factor for determining the number of gallons in a cubic foot.

PARTS₂O™ Accessories

Union Package, 2" NPT x 2" NPT

AT741603

Union Package, 2" NPT x 1-1/2" Slip

77703-0101



In-Ground & Above-Ground Pool Pumps

Save up to **\$300** PER YEAR
in energy costs.*

High Performance

Designed to move large amounts of water

Quiet Operation

Specially designed base dampens sound and vibration

Low Maintenance

Extra-large capacity trap with see-through lid

Easy Installation

Includes quick connect union

Easy-Open Drain Plug

Makes for tool-free winterizing and service

1-Year Warranty



TWO SPEED** (230 V ONLY)

1-1/2 HP UP TO 52,800 GAL
FPT20515

1 HP UP TO 43,200 GAL
FPT20510

SINGLE SPEED (115/230 V)

1-1/2 HP UP TO 52,800 GAL
AT251501

1 HP UP TO 43,200 GAL
AT251001

PERFORMANCE (GPM)										SLIP FIT PIPE SIZE		CARTON DIMS. (IN INCHES)	WEIGHT
MODEL/UPC	MOTOR VOLTAGE	HP	MOTOR SPEED	DISCHARGE HEIGHT ABOVE PUMPING LEVEL						SUCTION	DISCH.		
				35'	40'	45'	50'	55'	60'				
TWO SPEED** 1 HP (230 V ONLY)													
FPT20510 022315367159	230	1	HIGH	70	60	48	33	10	-	1-1/2"	1-1/2"	27" x 13" x 16" 18/PALLET	39 LBS.
		1/6	LOW	48	33	-	-	-	-				
TWO SPEED** 1-1/2 HP (230 V ONLY)													
FPT20515 022315367166	230	1-1/2	HIGH	85	80	70	60	50	35	1-1/2"	1-1/2"	27" x 13" x 16" 18/PALLET	39 LBS.
		1/4	LOW	50	40	20	-	-	-				

PERFORMANCE (GPM)										SLIP FIT PIPE SIZE		CARTON DIMS. (IN INCHES)	WEIGHT
MODEL/UPC	MOTOR VOLTAGE	HP	FOR POOLS UP TO (GAL.)	DISCHARGE HEIGHT ABOVE PUMPING LEVEL						SUCTION	DISCH.		
				35'	40'	45'	50'	55'	60'				
AT251001 0223151207226	115/230	1	43,200	86	80	69	60	50	-	1-1/2"	1-1/2"	27 x 13 x 16 18/PALLET	39 LBS.
AT251501 022315207233	115/230	1-1/2	52,800	112	107	99	90	81	72	1-1/2"	1-1/2"	27 x 13 x 16 18/PALLET	39 LBS.

*Models FPT20515 and FPT20510 only. Savings assumes 12 month operation of the pump and is compared to a single speed motor pump of the same size, for a 22,000 gallon pool running 7 hours a day, at an average electrical rate of \$0.20/kWh. To achieve the savings, a complete system with a timer is required. Actual savings may vary based on pump model, hours of operation, electrical rate and pool plumbing and configuration.

**For 2-speed operation, a 2-speed controller/timer is needed. Sold separately. Contact local pool dealer.



Models FPT20515 and FPT20510: Meets residential pool pump two-speed motor requirements for California Title 20 and Florida HB7135 energy compliant systems



Sprinkler & Centrifugal Pumps

When irrigating your lawn or moving large volumes of water, Flotec has the right product for you. Our corrosion-resistant sprinkler pumps are constructed of rugged, heavy-duty fiberglass-reinforced thermoplastic or rugged cast iron to stand up to seasonal changes.

Sprinkler Applications

Sprinkler systems that have single/multiple zones with more than 2-3 heads per zone, requiring greater than 20 gallons per minute. Movement of large volumes of water from water source to place of use.

Centrifugal Applications

Economical, general purpose centrifugal pumps can be used for water transfer, circulation, fountains, waterfalls, pressure boosting and sprinkling.

Product Line Overview

Cast iron and thermoplastic pumps available

Cast iron centrifugal pumps from 1/2 HP to 2 HP

1-year warranty on pumps

PARTS₂O™ Accessories

For a complete line of well pump and tank accessories see pages 77-80.

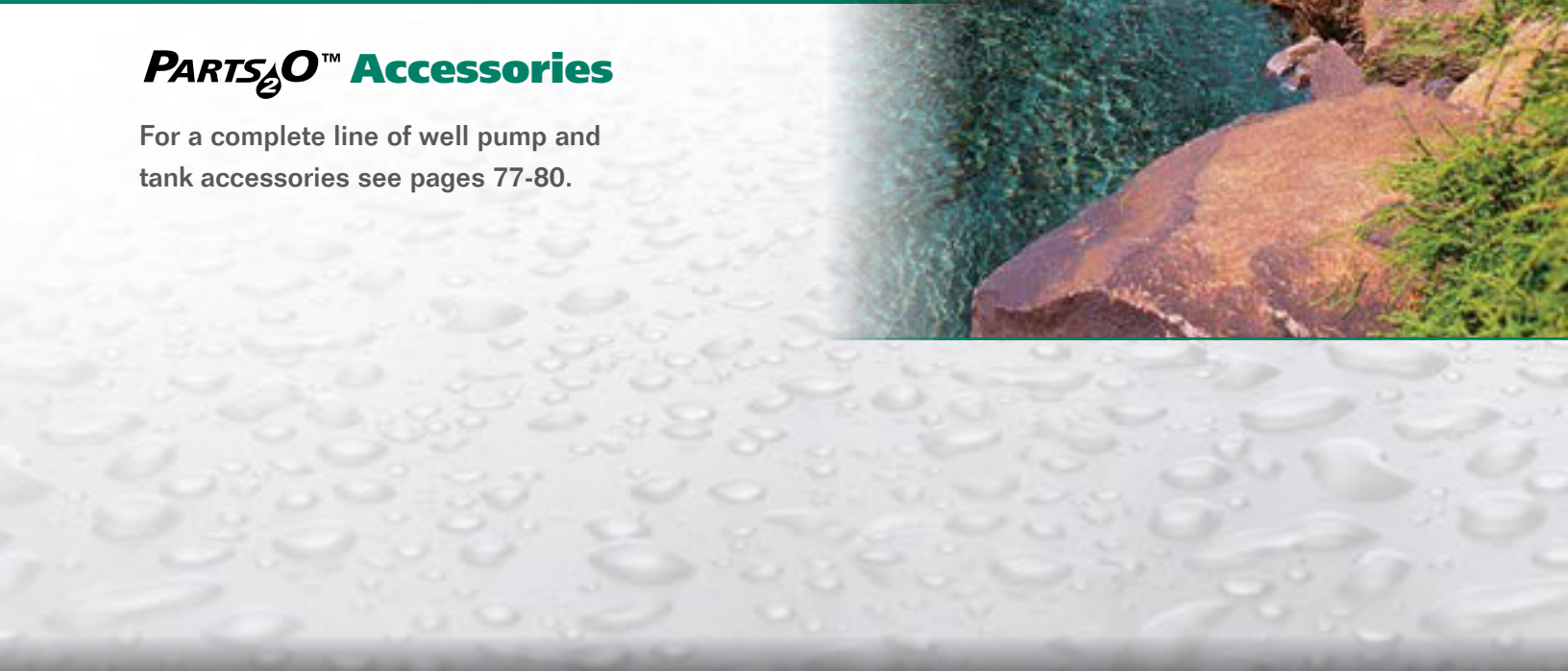

Thermoplastic Sprinkler Pumps

Superior Performance

At depths to water of 20' or less

Fiberglass-Reinforced Thermoplastic Pump Housing

For the highest corrosion resistance

High Capacity

Ideal for larger sprinkler zones or water transfer with 1-1/2" or 2" tapping for suction and discharge

Heavy-Duty Dual-Voltage Motor

Preset at 230V

Self-Priming After Pump Housing Is Initially Filled

Check valve or foot valve required, sold separately



Includes:
Threaded ports for pressure gauge and drain plug

1 HP 55 GPM FP5162	1-1/2 HP 67 GPM FP5172	2 HP 69 GPM FP5182
------------------------------	----------------------------------	------------------------------

PERFORMANCE (GPM)												NPT PIPE SIZE		WARRANTY	CARTON DIMS. (IN INCHES)	WT. (LBS.)	
MODEL/UPC	HP	VOLTS	DISTANCE OF PUMP ABOVE WATER	DISCHARGE PRESSURE (PSI)								SUCTION	DISCH.				
				10	15	20	25	30	35	40	45						50
FP5162 022315100701	1	230/115	5'	55	51	45	38	31	23	17	-	-	1-1/2"	1-1/2"	1 YEAR	21.813 x 12.313 x 13.125 24/PALLET	30.6
			10'	49	46	42	35	28	19	13	-	-					
			15'	48	45	39	32	24	16	8	-	-					
			20'	45	44	37	29	20	11	-	-	-					
FP5172 022315100718	1-1/2	230/115	5'	67	66	61	55	48	39	33	18	-	1-1/2"	1-1/2"	1 YEAR	21.813 x 12.313 x 13.125 24/PALLET	34.1
			10'	61	58	56	52	45	37	27	14	-					
			15'	56	55	54	51	44	34	20	8	-					
			20'	46	45	44	43	37	28	11	-	-					
FP5182 022315100725	2	230/115	5'	69	64	59	53	47	40	34	24	14	2"	2"	1 YEAR	21.563 x 12.813 x 15.375 18/PALLET	42
			10'	67	62	56	50	45	38	30	18	7					
			15'	65	60	54	48	42	35	27	13	-					
			20'	62	57	52	46	40	32	23	10	-					

Performance shown in gallons per minute

Cast Iron Sprinkler Pumps

Rugged Pump Housing

Durable, cast iron construction

Superior Performance

At depths to water of 25' or less

High Capacity

Ideal for larger sprinkler zones or water transfer

Heavy-Duty Dual-Voltage Motor

Preset at 230V

Self-Priming After Pump Housing Is Initially Filled

Check valve or foot valve required, sold separately

Drain Port Provided

For convenient winterizing



1-1/2 HP 55 GPM
FP5242

2 HP 64 GPM
FP5252

PERFORMANCE (GPM)										NPT PIPE SIZE		WARRANTY	CARTON DIMS. (IN INCHES)	WT. (LBS.)	
MODEL/UPC	HP	VOLTS	DISTANCE OF PUMP ABOVE WATER	DISCHARGE PRESSURE (PSI)						SUCTION	DISCH.				
				20	25	30	35	40	45			50			
FP5242 022315162792	1-1/2	230/115	5'	55	50	45	28	31	20	-	2"	1-1/2"	1 YEAR	24.063 x 17.938 x 13.563 12/PALLET	71.4
			10'	53	47	42	34	27	16	-					
			15'	51	45	39	30	22	-	-					
			20'	49	42	36	27	18	-	-					
			25'	46	39	32	22	12	-	-					
FP5252 022315162808	2	230/115	5'	64	58	53	45	38	28	19	2"	2"	1 YEAR	24.063 x 17.938 x 13.563 12/PALLET	86.2
			10'	62	56	50	42	35	24	13					
			15'	59	53	47	39	31	20	-					
			20'	57	50	44	35	26	-	-					
			25'	51	44	38	30	20	-	-					

Includes: Threaded ports for pressure gauge and drain plug

Cast Iron Centrifugal Pumps

Rugged Pump Housing

Durable, cast iron construction

Superior Performance

At depths to water of 25' or less

Heavy-Duty Dual-Voltage Motor

Preset at 230V

Easy Installation

Discharge can be rotated to horizontal or vertical installations



1/2 HP 22 GPM
FP5512

3/4 HP 31 GPM
FP5522

1 HP 47 GPM
FP5532

1-1/2 HP 59 GPM
FP5542

2 HP 68 GPM
FP5552

PERFORMANCE (GPM)								MAX. PRESS. (PSI)	NPT PIPE SIZE		WARRANTY	CARTON DIMS. (IN INCHES)	WT. (LBS.)
MODEL/UPC	HP	VOLTS	DISCHARGE PRESSURE (PSI)						SUCTION	DISCH.			
			25	30	35	40	45						
FP5512 022315135925	1/2	230/115	22	13	2	-	-	36	1-1/4"	1"	1 YEAR	19.813 x 10.063 x 10.818 32/PALLET	30.10
FP5522 022315135932	3/4	230/115	31	25	21	13	-	43	1-1/4"	1"	1 YEAR	19.813 x 10.063 x 10.818 32/PALLET	32.15
FP5532 022315135949	1	230/115	47	40	35	29	17	49	1-1/4"	1"	1 YEAR	19.813 x 10.063 x 10.818 40/PALLET	41.2
FP5542 022315135956	1-1/2	230/115	59	52	47	40	30	51	1-1/4"	1"	1 YEAR	19.813 x 10.063 x 10.818 40/PALLET	69
FP5552 022315135963	2	230/115	68	62	54	48	38	57	1-1/4"	1"	1 YEAR	19.813 x 10.063 x 10.818 40/PALLET	74

Includes: Threaded ports for pressure gauge and drain plug

Cast Iron • Multi-Stage High Pressure Booster Pumps

Typical Application

When you need to boost your existing pressure by 50 to 130 PSI. Residential, commercial or agricultural high pressure washing.

Stainless Steel Motor Shaft

Includes heavy-duty ball bearings, on-board thermal overload protection and rated for continuous duty

Heavy-Duty Cast Iron Pump Adapter and Discharge

3/4" suction and discharge



1/2 HP 110 PSI
FP5712

3/4 HP 150 PSI
FP5722

1 HP 190 PSI
FP5732

PERFORMANCE (GPM)								MAX. PRESSURE (PSI)	NPT PIPE SIZE		WARRANTY	CARTON DIMS. (IN INCHES)	WT. (LBS.)
MODEL/UPC	HP	VOLTS	DISCHARGE PRESSURE (PSI)						SUCTION	DISCH.			
			50	70	90	110	130						
FP5712 022315165755	1/2	230/115	13	11	7	-	-	110	3/4"	3/4"	1 YEAR	30.063 x 9.188 x 12.563 18/PALLET	38.9
FP5722 022315165762	3/4	230/115	-	13	10	8	-	150	3/4"	3/4"	1 YEAR	30.063 x 9.188 x 12.563 18/PALLET	42.9
FP5732 022315165779	1	230/115	-	-	13	12	10.5	190	3/4"	3/4"	1 YEAR	30.063 x 9.188 x 12.563 18/PALLET	48



Well Pumps and Tanks

In rural areas where city water isn't available, well pumps are used to pump water from below the ground. Tanks are used to store the water, which increases the life of a pump by reducing the number of cycles and maintains water pressure throughout the home. So whether you are replacing an existing well system or installing a new one, Flotec has the pump for you.

Product Line Overview

Jet Pumps

- Up to 21 GPM
- Complete jet/tank pump systems available
- Cast iron or thermoplastic construction
- 1-year warranty on pumps

Submersible Well Pumps

- 2-wire 4" subs
 - 1/2 HP - 1 HP available
 - 5' to 300' well depths
 - 3-year warranty
- 3-wire 4" subs
 - 1/2 HP - 1-1/2 HP available
 - 5' to 400' well depths
 - 3-year warranty

Pressure Tanks

- Heavy-gauge steel tanks for maximum durability
- Factory precharged for convenience
- 5-year warranty on tanks



PARTS₂O™ Accessories

For a complete line of well pump and tank accessories see pages 77-80.

Well Pump Application

4" SUBMERSIBLE

Pitless Adapter Installation

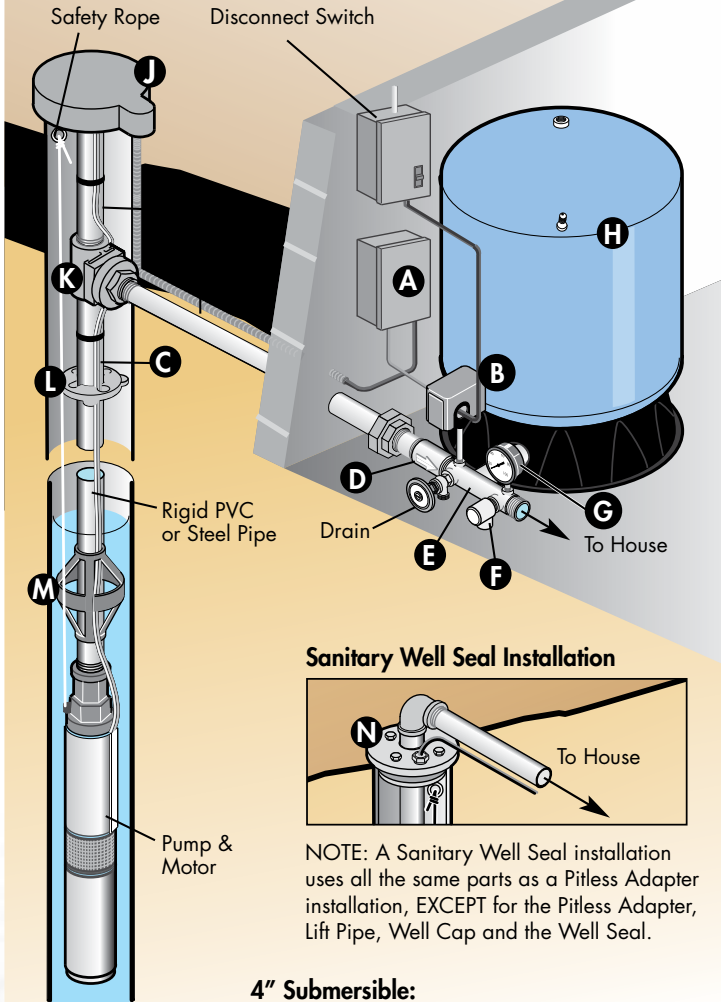

Sanitary Well Seal Installation

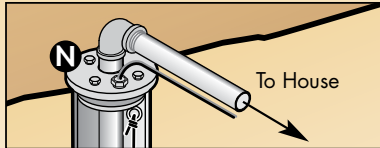

NOTE: A Sanitary Well Seal installation uses all the same parts as a Pitless Adapter installation, EXCEPT for the Pitless Adapter, Lift Pipe, Well Cap and the Well Seal.

4" Submersible:

- | | |
|-----------------------------|-------------------|
| A 3 Wire Pump Control Box | J Well Cap |
| B Pressure Switch | K Pitless Adapter |
| C Pipe | L Cable Protector |
| D Check Valve | M Torque Arrestor |
| E Tank Tee | N Well Seal |
| F Pressure Relief Valve | |
| G Pressure Gauge | |
| H Pre-charged Pressure Tank | |

SHALLOW WELL

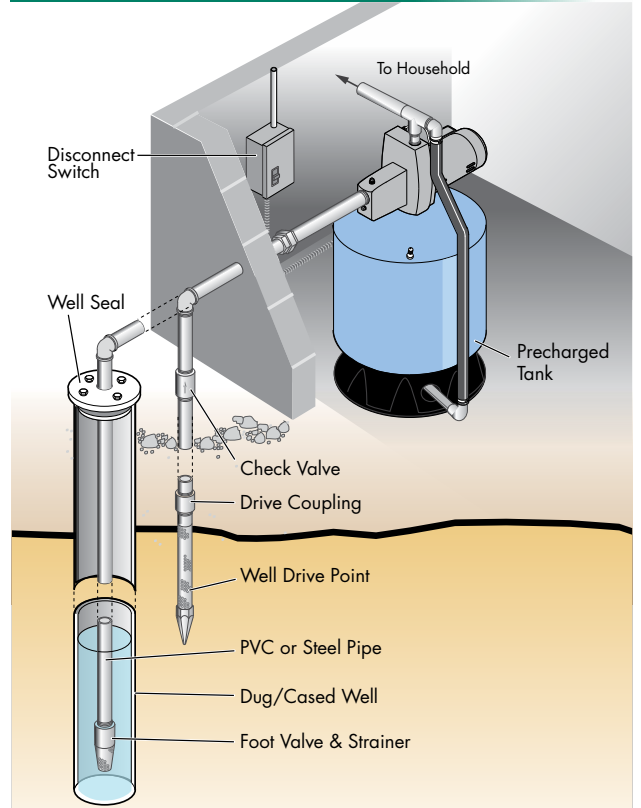

DEEP WELL

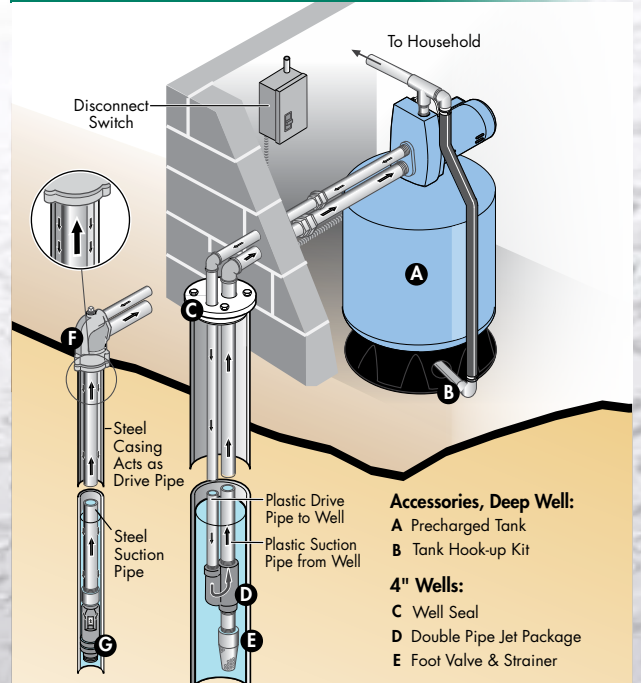

2" or 3" Single Pipe w/ Casing Adapter 4" Double Pipe w/ Well Seal

Accessories, Deep Well:

- A Precharged Tank
- B Tank Hook-up Kit
- 4" Wells:
- C Well Seal
- D Double Pipe Jet Package
- E Foot Valve & Strainer

2" Wells:

- F Casing Adapter
- G Single Pipe Jet Package w/Built-in Check Valve

Thermoplastic Shallow Well Jet Pumps

With Built-in Pressure Switch

Superior Performance

At depths to water of 25' or less

Fiberglass-Reinforced Thermoplastic Pump Housing

For the highest corrosion-resistance

Heavy-Duty Dual-Voltage Motor

1/2 HP preset at 115V; 3/4 HP & 1 HP preset at 230V

Self-Priming After Pump Housing Is Initially Filled

Check valve or foot valve required, sold separately



1/2 HP 8 GPM
FP4012

3/4 HP 12 GPM
FP4022

1 HP 18 GPM
FP4032

PERFORMANCE (GPM)							MAX PRESSURE SHUTOFF	SUCTION SIZE	DISCHARGE SIZE	VOLTAGE	PRESS. SWITCH	
DEPTH TO WATER	0'	5'	10'	15'	20'	25'					ON	OFF
FP4012	8	7.4	6.4	6.1	5.1	4.0	77 PSI	1-1/4"	1"	115/230	30	50
FP4022	12	10.3	9.7	8.2	7.1	5.1	78 PSI			115/230	30	50
FP4032	18	16.4	16.1	14.1	12.0	8.1	67 PSI			115/230	30	50

All performances shown in gallons per minute at 40 PSI discharge pressure.

MODEL	WARRANTY	UPC	CARTON DIMENSIONS	PALLET QTY.	WEIGHT
FP4012	1 YEAR	022315100572	22.813" x 11.063" x 10.5"	24	23 LBS.
FP4022	1 YEAR	022315100589	22.813" x 11.063" x 10.5"	24	26.9 LBS.
FP4032	1 YEAR	022315315150	22.813" x 11.063" x 10.5"	24	29.15 LBS.

Includes: 30/50 preset pressure switch

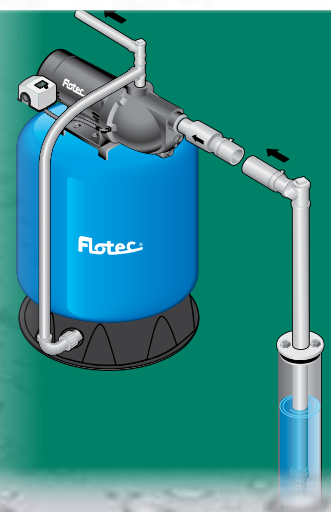

Cast Iron Shallow Well Jet Pumps

With Built-in Pressure Switch

Rugged Cast Iron Construction

For heavy-duty applications

Reliable Performance

At depths to water of 25' or less

Ready-to-Install Motor

Operates at 115V

Self-Priming After Pump Housing Is Initially Filled

Check valve or foot valve required, sold separately



1/2 HP 5.6 GPM
FP4105

PERFORMANCE (GPM)							MAX PRESSURE SHUTOFF	SUCTION SIZE	DISCHARGE SIZE	VOLTAGE	PRESSURE SWITCH	
DEPTH TO WATER	0'	5'	10'	15'	20'	25'					ON	OFF
FP4105	5.6	5.1	4.5	4.1	3.5	3.1	63 PSI	1"	1"	115	30	50

All performances shown in gallons per minute at 40 PSI discharge pressure.

MODEL	WARRANTY	UPC	CARTON DIMENSIONS	PALLET QTY.	WEIGHT
FP4105	1 YEAR	022315176225	15.200" x 9.4" x 11"	27	24.25 LBS.

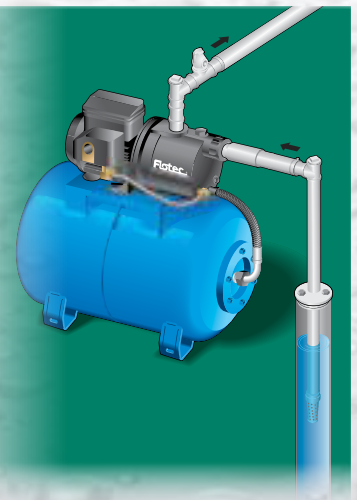

Includes: 30/50 preset pressure switch

Cast Iron Shallow Well Jet Pumps

High-Output Performance

Rugged Pump Housing

Durable cast iron construction

Superior Performance

At depths to water of 25' or less

Built-in Prewired Pressure Switch

Set for 30/50 PSI operation

Heavy-Duty Dual Voltage Motor

1/2 HP Preset at 115V;
3/4 HP and 1 HP preset at 230V



1/2 HP 8.5 GPM
FP4155

3/4 HP 19 GPM
FP4157

1 HP 21 GPM
FP4150

PERFORMANCE (GPM)							MAX PRESSURE SHUTOFF	SUCTION SIZE	DISCHARGE SIZE	VOLTAGE	PRESSURE SWITCH	
DEPTH TO WATER	0'	5'	10'	15'	20'	25'					ON	OFF
FP4155	8.5	7.5	6.5	6.0	5.0	3.5	65 PSI	1-1/4"	1"	115/230	30	50
FP4157	19.0	16.0	14.0	13.0	11.0	7.0	67 PSI			115/230	30	50
FP4150	21.0	20.0	18.0	16.0	13.0	9.0	70 PSI			115/230	30	50

All performances shown in gallons per minute at 30 PSI discharge pressure.

MODEL	WARRANTY	UPC	CARTON DIMENSIONS	PALLET QTY.	WEIGHT
FP4155	1 YEAR	022315361669	19" x 10.82" x 10.5"	48	38 LBS.
FP4157	1 YEAR	022315361676	19" x 10.82" x 10.5"	48	45 LBS.
FP4150	1 YEAR	022315361683	19" x 10.82" x 10.5"	48	53 LBS.

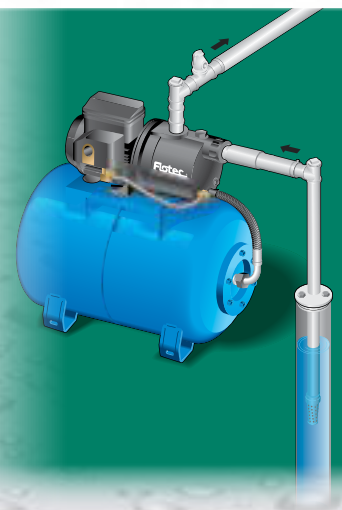

Includes: 30/50 preset pressure switch

Cast Iron Shallow Well Jet Pumps

With Built-in Pressure Switch

Rugged Pump Housing

Durable cast iron construction

Superior Performance

At depths to water of 25' or less

Heavy-Duty Dual-Voltage Motor

1/2 HP preset at 115V

3/4 HP preset at 230V

Self-Priming After Pump Housing Is Initially Filled

Check valve or foot valve required,
sold separately



1/2 HP 8.8 GPM
FP4112

3/4 HP 14.7 GPM
FP4122

PERFORMANCE (GPM)							MAX PRESSURE SHUTOFF	SUCTION SIZE	DISCHARGE SIZE	VOLTAGE	PRESSURE SWITCH	
DEPTH TO WATER	0'	5'	10'	15'	20'	25'					ON	OFF
FP4112	8.8	8.5	7.8	6.8	5.6	4.6	69 PSI	1-1/4"	1"	115/230	30	50
FP4122	14.7	14.4	12.8	11.8	9.4	7.3	70 PSI			115/230	30	50

All performances shown in gallons per minute at 40 PSI discharge pressure.

MODEL	WARRANTY	UPC	CARTON DIMENSIONS	PALLET QTY.	WEIGHT
FP4112	1 YEAR	022315100602	21.5" x 13.44" x 10.33"	24	41 LBS.
FP4122	1 YEAR	022315100619	21.5" x 13.44" x 10.33"	24	43.3 LBS.

Includes: 30/50 preset pressure switch

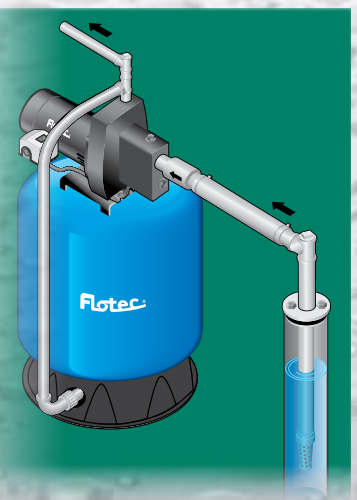

Stainless Steel Shallow Well Jet Pumps

With Built-in Pressure Switch

Heavy-Duty Stainless Steel Construction

For the highest corrosion-resistance

Superior Performance

At depths to water of 25' or less

Heavy-Duty Dual-Voltage Motor

Preset at 230V

Self-Priming After Pump Housing Is Initially Filled

Check valve or foot valve required, sold separately



3/4 HP 11 GPM
FP4822

1 HP 17.5 GPM
FP4832

PERFORMANCE (GPM)							MAX PRESSURE SHUTOFF	SUCTION SIZE	DISCHARGE SIZE	VOLTAGE	PRESSURE SWITCH	
DEPTH TO WATER	0'	5'	10'	15'	20'	25'					ON	OFF
FP4822	11	11	11	11	9	7	64 PSI	1-1/4"	1"	115/230	30	50
FP4832	17.5	16	14.5	12.5	10.5	7.5	81 PSI				30	50

All performances shown in gallons per minute at 40 PSI discharge pressure.

MODEL	WARRANTY	UPC	CARTON DIMENSIONS	PALLET QTY.	WEIGHT
FP4822	1 YEAR	022315160606	21.313" x 11.313" x 12.625"	18	29.05 LBS.
FP4832	1 YEAR	022315160613	21.313" x 11.313" x 12.625"	18	33.75 LBS.

Includes: 30/50 preset pressure switch

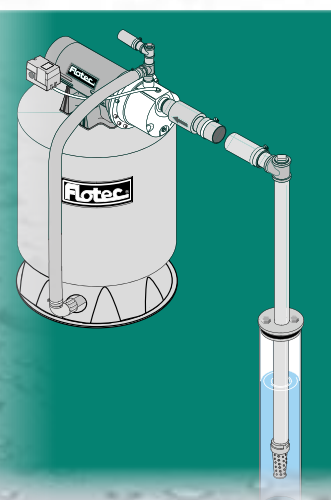

Complete Jet & Tank System

Ideal for Compact Installations

Where space is at a premium

Superior Performance

At depths to water of 25' or less

19-Gallon Pressure Tank, Precharged to 25 PSI

Corrosion-resistant, heavy-gauge steel construction with baked-on finish

Fiberglass-Reinforced Thermoplastic Pump Housing

For the highest corrosion and sand-abrasion resistance

Heavy-Duty Dual-Voltage Motor

Preset at 230V

Built-In Check Valve



3/4 HP 10 GPM FP2521

PERFORMANCE (GPM)					MAX PRESSURE SHUTOFF	SUCTION SIZE	DISCHARGE SIZE	VOLTAGE	PRESSURE SWITCH	
DEPTH TO WATER	5'	10'	15'	20'					ON	OFF
FP2521	10.2	8.7	7.6	5.8	70 PSI	1-1/4"	1"	115/230	30	50

All performances shown in gallons per minute at 40 PSI discharge pressure.

WARRANTY	UPC	CARTON DIMENSIONS	PALLET QTY.	WEIGHT
1 YEAR	022315381544	44.25" x 17.25" x 33"	2	78 LBS.

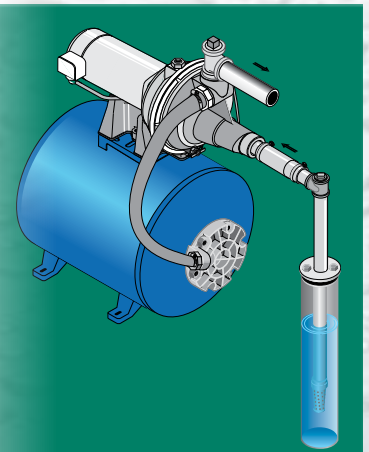

Includes: 30/50 preset pressure switch

Complete Jet & Tank System

With Thermoplastic Pump

Ideal for Compact Installations

Where space is at a premium

Superior Performance

At depths to water of 25' or less

**Precharged Pressure Tank with
15-Gallon Equivalent Capacity**

Corrosion-resistant, heavy-gauge steel
construction with baked-on finish

**Fiberglass Reinforced
Thermoplastic Pump Housing**

For the highest corrosion and sand-abrasion resistance

Heavy-Duty Dual-Voltage Motor

Preset at 115V



1/2 HP 8 GPM
FP401215H

PERFORMANCE (GPM)							MAX PRESSURE SHUTOFF	SUCTION SIZE	DISCHARGE SIZE	VOLTAGE	PRESS. SWITCH	
DEPTH TO WATER	0'	5'	10'	15'	20'	25'					ON	OFF
FP401215H	8	7.4	6.4	6.1	5.1	4.0	77 PSI	1-1/4"	1"	115/230	30	50

All performances shown in gallons per minute at 40 PSI discharge pressure.

WARRANTY	UPC	CARTON DIMENSIONS	PALLET QTY.	WEIGHT
1 YEAR	022315101265	24.063" x 14.563" x 27.938"	5	48.75 LBS.

Includes: 30/50 preset pressure switch

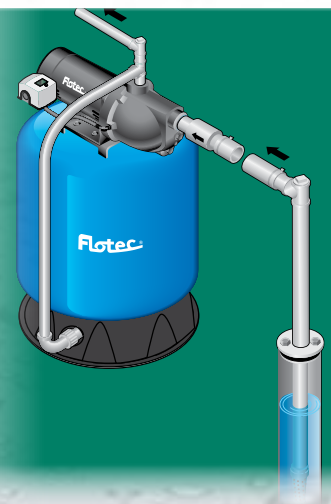

Complete Jet & Tank System

With Cast Iron Pump

Ideal for Compact Installations

Where space is at a premium

Reliable Performance

At depths to water of 25' or less

Precharged Pressure Tank with 15-Gallon Equivalent Capacity

Corrosion-resistant, heavy-gauge steel construction with baked-on finish

Durable Construction

Heavy-duty cast iron pump housing

Ready-to-Install Motor

Operates at 115V



1/2 HP 5.6 GPM
FP410515H

PERFORMANCE (GPM)							MAX PRESSURE SHUTOFF	SUCTION SIZE	DISCHARGE SIZE	VOLTAGE	PRESS. SWITCH	
DEPTH TO WATER	0'	5'	10'	15'	20'	25'					ON	OFF
FP410515H	5.6	5.1	4.5	4.1	3.5	3.1	63 PSI	1"	1"	115	30	50

All performances shown in gallons per minute at 40 PSI discharge pressure.

WARRANTY	UPC	CARTON DIMENSIONS	PALLET QTY.	WEIGHT
1 YEAR	022315176232	20.5" x 23" x 12.25"	18	36.8 LBS.

Includes: 30/50 preset pressure switch

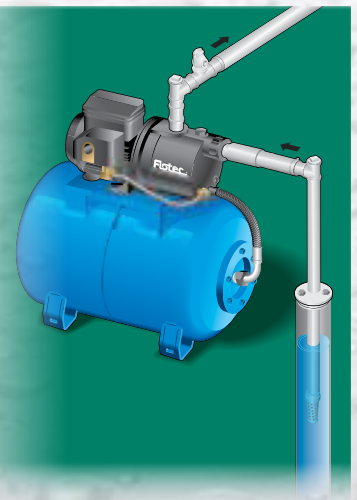

Complete Jet & Tank System

With High-Output Cast Iron Pump

Superior Performance

At depths to water of 25' or less

Compact System

Complete system with all necessary connectors from pump to tank

Heavy-Duty Dual-Voltage Motor

115/230V, Preset at 115V

Durable Construction

Heavy-duty cast iron pump housing

Precharged Pressure Tank with 15-Gallon Equivalent Capacity

Corrosion-resistant, heavy-gauge steel construction with baked-on finish



1/2 HP 8.5 GPM
FP415515H

PERFORMANCE (GPM)							MAX PRESSURE SHUTOFF	SUCTION SIZE	DISCHARGE SIZE	VOLTAGE	PRESS. SWITCH	
DEPTH TO WATER	0'	5'	10'	15'	20'	25'					ON	OFF
FP415515H	8.5	7.5	6.5	6.0	5.0	3.5	65 PSI	1-1/4"	1"	115/230	30	50

All performances shown in gallons per minute at 30 PSI discharge pressure.

WARRANTY	UPC	CARTON DIMENSIONS	PALLET QTY.	WEIGHT
1 YEAR	022315361713	23.25" x 14" x 26.88"	12	56 LBS.

Includes: 30/50 preset pressure switch

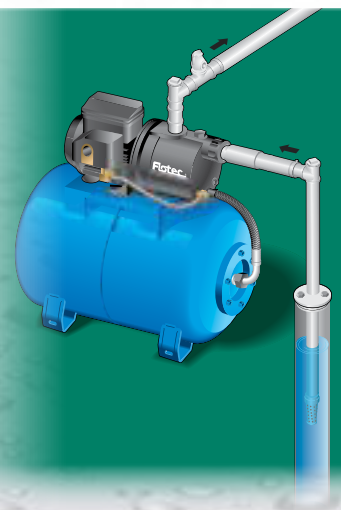

Thermoplastic Convertible Jet Pumps

For Deep or Shallow Wells

Superior Performance

At depths to water of 110' or less

Fiberglass-Reinforced Thermoplastic Pump Housing

For the highest corrosion resistance

Heavy-Duty Dual-Voltage Motor

3/4 HP & 1 HP preset at 230V
1/2 HP preset at 115V

Self-Priming After Pump Housing Is Initially Filled

Foot valve included with Jet Kit, sold separately

Prewired Pressure Switch

Preset for 30/50 PSI operation

Pressure Regulator



1/2 HP 5.9 GPM
FP4312

3/4 HP 7.5 GPM
FP4322

1 HP 9 GPM
FP4332

PERFORMANCE (GPM)															PRESS. SHUTOFF AT MAX DEPTH	JET KIT	WT. (LBS.)		
MODEL	UPC	HP	VOLTS	GALLONS PER MINUTE PUMPED AT DIFFERENT DEPTHS TO WATER IN FEET															
				5'	10'	15'	20'	30'	40'	50'	60'	70'	80'	90'				100'	110'
FP4312	022315100664	1/2	230/115				5.9	4.5	3.5	2.8	2.3	1.7	-	-	-	-	54 PSI	FP4800	54
Deep Well with 4" dia. casing or larger							5.3	4.3	3.4	2.5	1.9	1.5	-	-	-	-	54 PSI	FP4840	
Deep Well with 2" dia. casing							5.3	4.3	3.4	2.5	1.9	1.5	-	-	-	-	54 PSI	FP4840	
Shallow Well of 25' or less				9.0	7.8	6.6	5.7	4.3									62 PSI	FP4875	
FP4322	022315100671	3/4	230/115				7.5	6.5	5.1	4.0	3.0	2.5	1.8	1.5	1.0	-	56 PSI	FP4800	27.7
Deep Well with 4" dia. casing or larger							6.8	6.2	4.8	3.7	2.6	2.1	1.5	1.2	0.8	-	53 PSI	FP4840	
Deep Well with 2" dia. casing							6.8	6.2	4.8	3.7	2.6	2.1	1.5	1.2	0.8	-	53 PSI	FP4840	
Shallow Well of 25' or less				15.3	13.8	11.8	9.2	6.8	-	-	-	-	-	-	-	-	52 PSI	FP4875	
FP4332	022315100688	1	230/115				9.0	8.4	7.3	6.2	5.0	4.4	2.9	2.0	-	-	56 PSI	FP4800	30.4
Deep Well with 4" dia. casing or larger							8.4	7.8	6.7	5.6	4.4	3.5	3.0	2.5	2.0	1.4	62 PSI	FP4840	
Deep Well with 2" dia. casing							8.4	7.8	6.7	5.6	4.4	3.5	3.0	2.5	2.0	1.4	62 PSI	FP4840	
Shallow Well of 25' or less				20.7	18.3	15.8	12.3	8.5	-	-	-	-	-	-	-	-	52 PSI	FP4875	

All performances shown in gallons per minute at 40 PSI discharge pressure.

SUCTION SIZE	DRIVE	DISCHARGE SIZE	PRESSURE SWITCH		WARRANTY	CARTON DIMENSIONS (IN INCHES)
			ON	OFF		
1-1/4"	1"	1"	30	50	1 YEAR	20.94 x 12.31 x 12.19 (24/PALLET)

Includes: Pressure regulator, pressure gauge, 30/50 preset pressure switch

Cast Iron Convertible Jet Pumps

For Deep or Shallow Wells

Rugged Pump Housing

Durable cast iron construction

Superior Performance

At depths to water of 70' or less

Heavy-Duty Dual-Voltage Motor

3/4 HP preset at 230V
1 HP preset at 230V
1/2 HP preset at 115V

Prewired Pressure Switch

Preset for 30/50 PSI operation

Self-Priming After Pump Housing Is Initially Filled

Check valve or foot valve required, sold separately



2" jet kit sold separately

Ejector Kit Included for 4" Wells or Larger

1/2 HP 3.5 GPM
FP4205

3/4 HP 7 GPM
FP4207

1 HP 10 GPM
FP4210

PERFORMANCE (GPM)														PRESS. SHUTOFF AT MAX DEPTH	WT (LBS.)
MODEL	UPC	HP	VOLTS	GALLONS PER MINUTE PUMPED AT DIFFERENT DEPTHS TO WATER IN FEET											
				0'	5'	10'	15'	20'	30'	40'	50'	60'	70'		
FP4205	022315361690	1/2	230/115	-	-	-	-	-	3.5	3.0	2.5	2.0	1.0	65 PSI	21
Deep Well with 4" diameter casing or larger															
Shallow Well of 25' or less				10.0	9.5	9.0	8.0	6.5	-	-	-	-	-	54 PSI	
FP4207	022315363038	3/4	230/115	-	-	-	-	-	7.0	6.0	4.5	3.5	2.5	65 PSI	21
Deep Well with 4" diameter casing or larger															
Shallow Well of 25' or less				16.0	14.5	13.5	12.0	10.0	-	-	-	-	-	70 PSI	
FP4210	022315361706	1	230/115	-	-	-	-	-	10.0	8.0	6.0	4.5	3.0	65 PSI	24
Deep Well with 4" diameter casing or larger															
Shallow Well of 25' or less				17.0	15.0	13.5	12.5	10.0	-	-	-	-	-	70 PSI	

All performances shown in gallons per minute at 30 PSI discharge pressure.

SUCTION SIZE	DRIVE	DISCHARGE SIZE	PRESSURE SWITCH		WARRANTY	CARTON DIMENSIONS (IN INCHES)
			ON	OFF		
1-1/4"	1"	1"	30	50	1 YEAR	17.32 x 13.34 x 10.45 (48/PALLET)

Includes: Pressure regulator, pressure gauge, 30/50 preset pressure switch

Cast Iron Convertible Jet Pumps

For Deep or Shallow Wells

Rugged Pump Housing

Durable cast iron construction

Superior Performance

At depths to water of 100' or less
(jet kit sold separately)

Heavy-Duty Dual-Voltage Motor

3/4 HP preset at 230V
1/2 HP preset at 115V

Prewired Pressure Switch

Preset for 30/50 PSI operation

Self-Priming After Pump Housing Is Initially Filled

Foot valve included with Jet Kit, sold separately



1/2 HP 5.9 GPM
FP4212

3/4 HP 7.5 GPM
FP4222

PERFORMANCE (GPM)																PRESS. SHUTOFF AT MAX DEPTH	JET KIT	WT (LBS.)
MODEL	UPC	HP	VOLTS	5'	10'	15'	20'	30'	40'	50'	60'	70'	80'	90'	100'			
FP4212	022315100633	1/2	230/115				5.9	4.5	3.5	2.8	2.3	1.7	-	-	-	54 PSI	FP4800	21
Deep Well with 4" dia. casing or larger							5.3	4.3	3.0	2.5	1.9	1.5	1.1	-	-	54 PSI	FP4840	
Deep Well with 2" dia. casing																60 PSI	FP4855	
Shallow Well with single pipe				7.9	7.1	6.3	5.4	-	-	-	-	-	-	-	-			
FP4222	022315100640	3/4	230/115				7.5	6.5	5.1	4.0	3.0	2.5	1.8	1.5	1.0	56 PSI	FP4800	24
Deep Well with 4" dia. casing or larger							6.8	6.2	4.8	3.7	2.6	2.1	1.5	1.2	0.8	53 PSI	FP4840	
Deep Well with 2" dia. casing																63 PSI	FP4855	
Shallow Well with single pipe				11.9	10.8	9.5	7.5	-	-	-	-	-	-	-	-			

All performances shown in gallons per minute at 40 PSI discharge pressure.

SUCTION SIZE	DRIVE	DISCHARGE SIZE	PRESSURE SWITCH		WARRANTY	CARTON DIMENSIONS (IN INCHES)
			ON	OFF		
1-1/4"	1"	1"	30	50	1 YEAR	17.32 x 13.34 x 10.45 (48/PALLET)

Includes: Pressure regulator, 30/50 preset pressure switch

Complete Jet & Tank System

For Deep or Shallow Wells

Superior Performance

At depths to water of 70' or less

Compact System

Complete system with pressure gauge, pressure switch, pressure regulator, jet kit and all necessary connectors from pump to tank

Heavy-Duty Dual-Voltage Motor

Preset at 115V

Durable Construction

Heavy-duty cast iron pump housing

Precharged Pressure Tank with 15-Gallon Equivalent Capacity

Corrosion-resistant, heavy-gauge steel construction with baked-on finish



2" jet kit sold separately

Ejector Kit Included
for 4" Wells or Larger

1/2 HP

PERFORMANCE														PRESS. SHUTOFF AT MAX DEPTH	WT (LBS.)
MODEL	UPC	HP	VOLTS	GALLONS PER MINUTE PUMPED AT DIFFERENT DEPTHS TO WATER IN FEET											
				0'	5'	10'	15'	20'	30'	40'	50'	60'	70'		
FP420515H	022315361720	1/2	230/115	-	-	-	-	-	3.5	3.0	2.5	2.0	1.0	65 PSI	56
Deep Well with 4" diameter casing or larger				10	9.5	9	8	6.5	-	-	-	-	-	54 PSI	
Shallow Well of 25' or less				10	9.5	9	8	6.5	-	-	-	-	-	54 PSI	

All performances shown in gallons per minute at 30 PSI discharge pressure.

SUCTION SIZE	DRIVE	DISCHARGE SIZE	PRESSURE SWITCH		WARRANTY	CARTON DIMENSIONS (IN INCHES)
			ON	OFF		
1-1/4"	1"	1"	30	50	1 YEAR	23.25 x 14 x 26.88

Includes: 30/50 preset pressure switch

Cast Iron Jet Pump

Vertical Deep Well

Rugged Housing

Durable cast iron construction

Superior Performance

At depths to water of 260'

High Capacity

Up to 12 gallons per minute at 50 PSI

Heavy-Duty Dual-Voltage Motor

Preset at 230V

Prewired Factory-Set 40/60 Pressure Switch

Jet Kit Sold Separately



1 HP 12 GPM
FP4432

PERFORMANCE	GALLONS PER MINUTE PUMPED AT DIFFERENT DEPTHS TO WATER IN FEET																
	30'	40'	50'	60'	70'	80'	90'	100'	110'	120'	130'	140'	180'	200'	220'	240'	260'
Deep Well with 4" diameter casing or larger (FP4800)	12.0	11.5	11.0	10.4	9.6	8.8	7.4	6.1	5.0	4.9	4.7	4.5	2.9	2.3	1.7	1.2	0.8
Deep Well with 2" diameter casing (FP4840)	12.0	11.2	10.7	9.4	8.3	7.3	6.3	5.0	5.0	4.9	4.3	4.2	1.8	-	-	-	-

*All performances shown in gallons per minute at 50 PSI discharge pressure.
Pipe size required: 1-1/4" suction, 1" drive, 1" discharge

SUCTION SIZE	DRIVE	DISCHARGE SIZE	WARRANTY	UPC	CARTON DIMENSIONS	PALLET QTY.	WEIGHT
1-1/4"	1"	1"	1 YEAR	022315200791	11.88" x 15.38" x 26.63"	18	73.2 LBS.

Includes: 40/60 preset pressure switch, pressure gauge, mounting feet

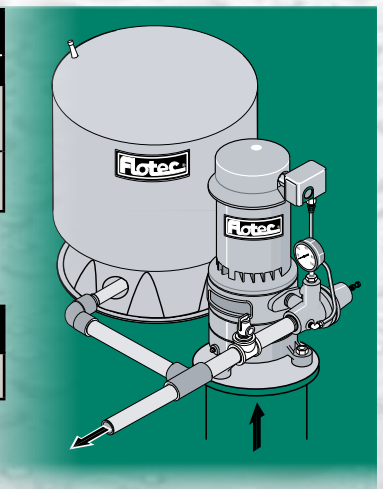

2-Wire, 4" Submersible Well Pumps

**For Residential Water Systems
or Agricultural Applications**

Pumps to depth of 300'

High Performance

Proven floating stack impeller design for sand resistance and reduced sand locking

Durable Construction

Stainless steel pump and motor housing



1/2 HP – 1 HP 10-14 GPM

PERFORMANCE																	
MODEL/ UPC	HP	GPM SERIES	VOLTS	GALLONS PER MINUTE PUMPED AT DIFFERENT DEPTHS TO WATER IN FEET											DISCHARGE	CARTON DIMS. (IN INCHES)	WEIGHT (LBS.)
				20'	40'	60'	80'	100'	150'	200'	250'	300'	350'	400'			
FP2211 022315155787	1/2	10	115	13.2	12.2	10.9	9.6	8.1	2	-	-	-	-	-	1-1/4"	4.8 x 4.8 x 34	21
FP2212 022315100800	1/2	10	230	13.2	12.2	10.9	9.6	8.1	2	-	-	-	-	-	1-1/4"	4.8 x 4.8 x 33	21
FP2222 022315100817	3/4	10	230	14.8	14.2	13.4	12.6	11.7	8.8	5.2	-	-	-	-	1-1/4"	4 x 4.8 x 34.3	24
FP2232 022315100824	1	10	230	-	-	14.7	14	13.4	11.7	9.7	7.3	4.4	-	-	1-1/4"	4.6 x 5 x 29	27

*All performances shown in gallons per minute at 40 PSI discharge pressure at the top of the well.

Optimal pump performance

3-Wire, 4" Submersible Well Pumps

**For Residential Water Systems
or Agricultural Applications**

Pumps to depth of 400'

High Performance

Proven floating stack impeller design for sand resistance and reduced sand locking

Durable Construction

Stainless steel pump and motor housing



Control Box Included

1/2 HP – 1 HP 14-26.2 GPM

PERFORMANCE																	
MODEL/ UPC	HP	GPM SERIES	VOLTS	GALLONS PER MINUTE PUMPED AT DIFFERENT DEPTHS TO WATER IN FEET											DISCHARGE	CARTON DIMS. (IN INCHES)	WEIGHT (LBS.)
				20'	40'	60'	80'	100'	150'	200'	250'	300'	350'	400'			
FP3212 022315101944	1/2	10	230	13.2	12.2	10.9	9.6	8.1	2	-	-	-	-	-	1-1/4"	21 x 12.5 x 12.3	25
FP3222 022315101951	3/4	10	230	14.8	14.2	13.4	12.6	11.7	8.8	5.2	-	-	-	-	1-1/4"	6 x 4.6 x 40	28
FP3232 022315101968	1	10	230	-	-	14.7	14	13.4	11.7	9.7	7.3	4.4	-	-	1-1/4"	6 x 4.6 x 40	31
FP3242 022315100916	1-1/2	10	230	-	-	-	-	14.9	13.8	12.5	11.2	10.4	7.9	5.8	1-1/4"	6 x 4.5 x 49	41
FP3332 022315101975	1	20	230	27	24.5	22.0	19.4	16.8	2.6	-	-	-	-	-	1-1/4"	5 x 4.5 x 43.5	30
FP3342 022315163294	1-1/2	20	230	-	-	26.2	24.3	22.3	17.3	8	-	-	-	-	1-1/4"	48.9 x 5.8 x 4.6	41

*All performances shown in gallons per minute at 40 PSI discharge pressure at the top of the well.

 **Optimal pump performance**

Includes: Control box

2 Gallon Precharged Pressure Tanks

Vertical Design

Factory Precharged for Efficiency

Extends pump life by providing more water between pump cycles compared to standard tanks

Heavy-Gauge Steel Construction

For maximum durability and extended life

Precision Press Fit Design

Minimizes gaps between components, reducing corrosion and seam leaks

Convenient Size

Ideal for small water systems and lower-flow applications

Easy Maintenance

NSF-61-approved tank is non-replaceable diaphragm



2 GAL FP7105

PERFORMANCE

MODEL	STANDARD TANK EQUIVALENCY	ACTUAL TANK CAPACITY	DRAWDOWN COMPARISON						STYLE	PLUMBING CONNECTION
			PRECHARGED			STANDARD				
			20/40	30/50	40/60	20/40	30/50	40/60		
FP7105	6 Gallons	2 Gallons	0.7	0.6	0.5	0.9	0.6	-	Vertical	3/4"

MODEL	WARRANTY	UPC	CARTON DIMENSIONS	PALLET QTY.	WEIGHT
FP7105	5 YEAR	022315101449	8.6" x 9" x 13.6"	162	5 LBS.

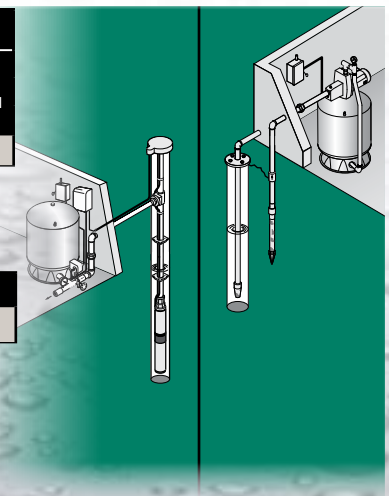

6 Gallon Precharged Pressure Tanks

Vertical or Horizontal Design

Factory Precharged to 40 PSI for Efficiency

Extends pump life by providing more water between pump cycles compared to standard tanks

Heavy-Gauge Steel Construction

For maximum durability and extended life

Precision Press Fit Design

Minimizes gaps between components, reducing corrosion and seam leaks

Convenient Size

Ideal for cabins and summer homes

Easy Maintenance

NSF-61-approved tank replaceable air/water separator



6 GAL FP7100

6 GAL FP7100H (Horizontal)

PERFORMANCE										
MODEL	STANDARD TANK EQUIVALENCY	ACTUAL TANK CAPACITY	DRAWDOWN COMPARISON						STYLE	PLUMBING CONNECTION
			PRECHARGED			STANDARD				
			20/40	30/50	40/60	20/40	30/50	40/60		
FP7100	15 Gallons	6 Gallons	2.2	1.8	1.8	2.3	1.5	1.1	Vertical	3/4"
FP7100H	15 Gallons	6 Gallons	2.2	1.8	1.8	2.3	1.5	1.1	Horizontal	3/4"

MODEL	WARRANTY	UPC	CARTON DIMENSIONS	PALLET QTY.	WEIGHT
FP7100	5 YEAR	022315101098	14" x 13" x 17"	18	18.9 LBS.
FP7100H	5 YEAR	022315101081	14" x 13" x 17"	18	18 LBS.

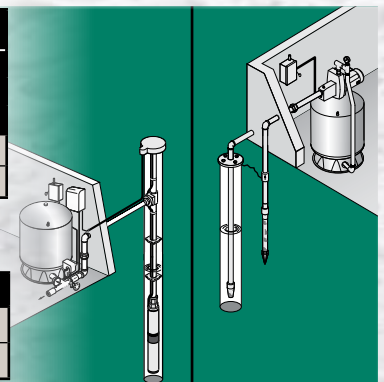

19 Gallon Precharged Pressure Tanks

Vertical or Horizontal Design

Factory Precharged to 40 PSI for Efficiency

Extends pump life by providing more water between pump cycles compared to standard tanks

Heavy-Gauge Steel Construction

For maximum durability and extended life

Precision Press Fit Design

Minimizes gaps between components, reducing corrosion and seam leaks

Convenient Size

Ideal for household applications

Easy Maintenance

NSF-61-approved tank
Replaceable air/water separator



19 GAL FP7110T

19 GAL FP7110TH

19 GAL FP7110

PERFORMANCE										
MODEL	STANDARD TANK EQUIVALENCY	ACTUAL TANK CAPACITY	DRAWDOWN COMPARISON						STYLE	PLUMBING CONNECTION
			PRECHARGED			STANDARD				
			20/40	30/50	40/60	20/40	30/50	40/60		
FP7110T	42 Gallons	19 Gallons	6.9	5.9	5.0	6.5	4.3	3.0	Vertical	1"
FP7110TH	42 Gallons	19 Gallons	6.9	5.9	5.0	6.5	4.3	3.0	Horizontal	1"
FP7110	42 Gallons	19 Gallons	6.9	5.9	5.0	6.5	4.3	3.0	Vertical	1"

MODEL	WARRANTY	UPC	CARTON DIMENSIONS	PALLET QTY.	WEIGHT
FP7110T	5 YEAR	022315101203	17" x 17" x 29"	4	36.5 LBS.
FP7110TH	5 YEAR	022315101388	18" x 17" x 27"	6	38.5 LBS.
FP7110	5 YEAR	022315101098	14" x 13" x 17"	18	18.9 LBS.

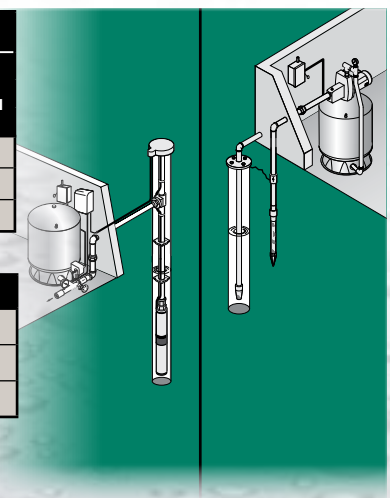

35, 50, 85 & 119 Gallon Precharged Pressure Tanks

Vertical Design

Factory Precharged to 40 PSI for Efficiency

Extends pump life by providing more water between pump cycles compared to standard tanks

Heavy-Gauge Steel Construction

For maximum durability and extended life

Precision Press Fit Design

Minimizes gaps between components, reducing corrosion and seam leaks

Large Capacity

Ideal for high demand water usage

Easy Maintenance

NSF-61-approved tank
Replaceable air/water separator



35 GAL FP7120

50 GAL FP7125

85 GAL FP7130

119 GAL FP7135

PERFORMANCE										
MODEL	STANDARD TANK EQUIVALENCY	ACTUAL TANK CAPACITY	DRAWDOWN COMPARISON						STYLE	PLUMBING CONNECTION
			PRECHARGED			STANDARD				
			20/40	30/50	40/60	20/40	30/50	40/60		
FP7120	82 Gallons	35 Gallons	12.7	10.7	9.3	12.7	8.4	5.9	Vertical	1"
FP7125	120 Gallons	50 Gallons	18.3	15.5	13.4	18.6	12.2	8.8	Vertical	1-1/4"
FP7130	220 Gallons	85 Gallons	30.0	26.0	22.0	34.1	22.4	16.1	Vertical	1-1/4"
FP7135	320 Gallons	119 Gallons	41.3	35.4	31.0	47.0	29.0	24.4	Vertical	1-1/4"

MODEL	WARRANTY	UPC	CARTON DIMENSIONS	PALLET QTY.	WEIGHT
FP7120	5 YEAR	022315101111	21" x 21" x 34"	4	61.6 LBS.
FP7125	5 YEAR	022315101128	5" x 25" x 33"	2	82.35 LBS.
FP7130	5 YEAR	022315101135	25" x 25" x 56"	2	117.7 LBS.
FP7135	5 YEAR	022315173675	25" x 25" x 70"	2	153 LBS.

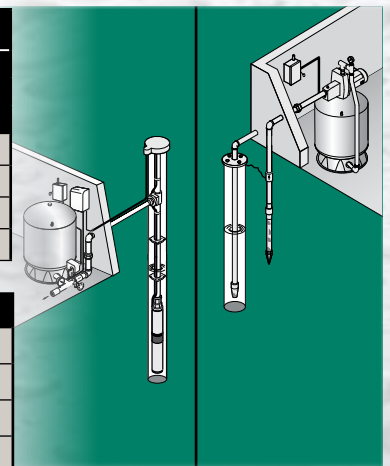

Epoxy-Lined Standard Tanks

Vertical or Horizontal Design

Typical Applications

Replaces any standard galvanized, glass-lined or epoxy-lined tank for applications such as retention tanks, holding tanks and pressure tanks

Precision Press Fit Design

Minimizes gaps between components, reducing corrosion and seam leaks

Heavy-Gauge All-Steel Construction

Tough appliance-like finish for extended life



30 GAL FP7210 (Horizontal)

42 GAL FP7230
FP7235

MODEL	TANK SIZE	STYLE	DIAMETER	HEIGHT	LENGTH	PIPING SIZE	DRAWDOWN (GALLONS)		
							20-40	30-50	40-60
FP7210	30 gallons	Horizontal	16"	17-1/2"	36-1/2"	3/4"	5.2	4.4	3.9
FP7230	42 gallons	Vertical	16"	53-1/2"	N/A	1-1/4"	6.9	5.9	5.2
FP7235	42 gallons	Vertical	20"	36-5/8"	N/A	1-1/4"	6.7	5.8	5.0

MODEL	WARRANTY	UPC	CARTON DIMENSIONS	PALLET QTY.	WEIGHT
FP7210	1 YEAR	022315364783	38" x 16" x 18"	6	51 LBS.
FP7230	1 YEAR	022315101234	17" x 17" x 55"	6	56.3 LBS.
FP7235	1 YEAR	022315135901	21" x 21" x 38"	4	58 LBS.

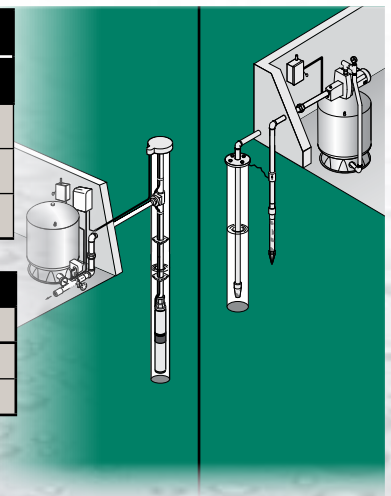

Epoxy-Lined Standard Tanks

Vertical Design

Typical Applications

Replaces any standard galvanized, glass-lined or epoxy-lined tank for applications such as retention tanks, holding tanks and pressure tanks

Precision Press Fit Design

Minimizes gaps between components, reducing corrosion and seam leaks

Heavy-Gauge All-Steel Construction

Tough appliance-like finish for extended life



85 GAL FP7240

120 GAL FP7250

MODEL	TANK SIZE	STYLE	DIAMETER	HEIGHT	LENGTH	PIPING SIZE	DRAWDOWN (GALLONS)		
							20-40	30-50	40-60
FP7240	85 gallons	Vertical	24"	51"	N/A	1-1/4"	14.3	12.3	10.7
FP7250	120 gallons	Vertical	24"	68"	N/A	1-1/4"	19.9	17.1	14.9

MODEL	WARRANTY	UPC	CARTON DIMENSIONS	PALLET QTY.	WEIGHT
FP7240	1 YEAR	022315135918	25" x 25" x 52"	2	109.35 LBS.
FP7250	1 YEAR	022315162938	25" x 25" x 70"	2	142 LBS.

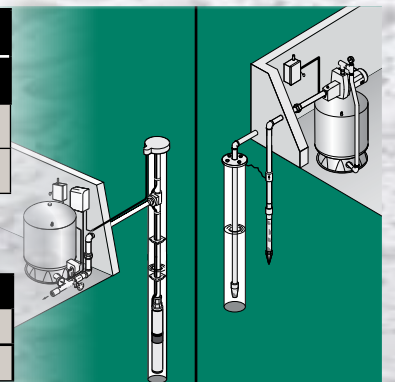



Jet Pump Accessories

Pressure Switches

20/40 PSI	FP2040-P2
30/50 PSI	TC2151-P2
30/50 PSI with Low-Pressure Cutoff	FP217-1140-P2
40/60 PSI	TC2153-P2
Pressure Relief Valve	TC2160LF-P2
Pressure Regulator Valve Kit	FPAPR-P2
Pressure Switch Tubing Kit	FPASFK-P2
Pressure Gauge	TC2104-P2
Air Volume Control Kit	TC2120-P2
Tank Hook-up Kit	FP8110-P2
Tank Pump Bracket	TNKBR-P2



Jet Pump Overhaul Kits

Convertible & Shallow Well Jet Kit For use with FP4112 and FP4212	FPP1560-P2
Convertible & Shallow Well Jet Kit For use with FP4122 and FP4222	FPP1561-P2
Convertible Jet Kit For use with FP4312	FPP1511-P2
Shallow Well For use with FP4012-08	FPP1520-P2
Shallow Well For use with FP4012-08	FPP1521-P2



Seal and Gasket Kits

Shallow Well Jet For use with FP4000 (-08)	FPP1530-P2
Convertible and Shallow Well Jet For use with FP4112, FP4122, FP4222	FPP1550-P2



Ejector Kits

Shallow Well For use with FP4300	FP4875-P2
4" Double Pipe Deep Well For use with FP4200, FP4300, FP4400	FP4800-P2
2" Single Pipe Deep Well For use with FP4200, FP4300, FP4400	FP4840-P2



Submersible Pump Accessories

Torque Arrestor	FP97-33-P2
Wire Guard	TC2171-P2
Air Volume Control Kit	FPE238-2-P2
Wire Splice Kit	TC2172-P2

Pitless Adapters

1"	A10148LF-P2
1-1/4"	A10113LF-P2

Wiring Kits

For 2-Wire Pumps, 1 HP and Under	FP85-P2
For 3-Wire Pumps, 2 HP and Under	FP86-P2
Installation Wiring Kit for 3-Wire Pumps, 2 HP and Under	FP87-P2

Includes 150' 12-gauge 3-wire plus ground, brass tank tee, pressure switch, pressure gauge, torque arrestor and wire splice kit



Submersible Pump Accessories (cont.)

Brass Check Valves

3/4"	TC2506LF-P2
1"	TC2502LF-P2
1-1/4"	TC2505LF-P2
1-1/2"	TC2507LF-P2
2"	FPU212-36LF-P2



Brass Foot Valves

3/4"	TC2508LF-P2
1"	TC2503LF-P2
1-1/4"	TC2501LF-P2
1-1/2"	TC2504LF-P2



Brass Barb Fittings

1" x 1"	FPU78-993LF-P2
1-1/4" x 1"	FPU78-992LF-P2



Discharge Tees

1"	FPADT-P2
1-1/2"	FPADT-15-P2



Brass Tank Tees

4"	TCU78-635DLF-P2
11"	FP78-7LF-P2



FP78-7LF-P2



TCU78-635DLF-P2

Well Accessories

Well Seals

4" x 1-1/4" drop pipe sizes	FP216-13-P2
4" x 1-1/4" x 1" drop pipe sizes	FP216-92-P2
6" x 1" drop pipe sizes	FP216-6-P2
6" x 1-1/4" x 1" drop pipe sizes	FP216-94-P2
Well Cap	FPU216-111-P2



Well Drive Points

1-1/4" x 36"	J208-2-P2
1-1/4" x 48"	J48-12-P2
Well Point Drive Coupling	J11-6-P2
Well Point Drive Cap	J70-1-P2



Pitcher Pump	FPHP25-P2
Tank Fill Pump-up Float Switch	FPW217-180B-P2

Hydrants

1' bury depth	FPH1-P2
2' bury depth	FPH2-P2
3' bury depth	FPH3-P2
4' bury depth	FPH4-P2
5' bury depth	FPH5-P2
6' bury depth	FPH6-P2
8' bury depth	FPH8-P2
Hydrant Installation Kit	FPHK-P2
Hydrant Repair Kit	FPYRK1-P2
Hydrant Replacement Head	FPHH-P2
Hydrant Handle Replacement	SD-RHH-P2



Limited Warranty

This Limited Warranty is effective June 1, 2011 and replaces all undated warranties and warranties dated before June 1, 2011.

FLOTEC warrants to the original consumer purchaser ("Purchaser" or "You") that its products are free from defects in material and workmanship for a period of twelve (12) months from the date of the original consumer purchase. If, within twelve (12) months from the original consumer purchase, any such product shall prove to be defective, it shall be repaired or replaced at FLOTEC's option, subject to the terms and conditions set forth herein. Note that this limited warranty applies to manufacturing defects only and not to ordinary wear and tear. All mechanical devices need periodic parts and service to perform well. This limited warranty does not cover repair when normal use has exhausted the life of a part or the equipment.

The original purchase receipt and product warranty information label are required to determine warranty eligibility. Eligibility is based on purchase date of original product – not the date of replacement under warranty. The warranty is limited to repair or replacement of original purchased product only, not replacement product (i.e. one warranty replacement allowed per purchase). Purchaser pays all removal, installation, labor, shipping, and incidental charges.

For parts or troubleshooting assistance, DO NOT return product to your retail store - contact FLOTEC Customer Service at 1-800-365-6832.

Claims made under this warranty shall be made by returning the product (except sewage pumps, see below) to the retail outlet where it was purchased immediately after the discovery of any alleged defect. FLOTEC will subsequently take corrective action as promptly as reasonably possible. No requests for service will be accepted if received more than 30 days after the warranty expires. Warranty is not transferable and does not apply to products used in commercial/rental applications.

Sewage Pumps

DO NOT return a sewage pump (that has been installed) to your retail store. Contact FLOTEC Customer Service. Sewage pumps that have seen service and been removed carry a contamination hazard with them.

If your sewage pump has failed:

- Wear rubber gloves when handling the pump;
- For warranty purposes, return the pump's cord tag and original receipt of purchase to the retail store;
- Dispose of the pump according to local disposal ordinances.

Exceptions to the Twelve (12) Month Limited Warranty

Product	Warranty Period
FP0F360AC, FP0FDC, FPD21SA, FPD21HC	90 days
FP0S1775A, FP0S1790PCA, FP0S2400A, FP0S2450A, FP0S4100X, FP2800DCC, FP0CP-20ULST, FPPSS3000, FPSC2150A, FPSC3150A, FPCI3350, FPCI5050, FPDC30, FPCC5030	2 Years
4" Submersible Well Pumps, FP0S3200A, FP0S3250A, FP0S6000A, FPSC1725X, FPSC2200A, FPSC2250A, FPSE3601A, FPPSS5000, FPSC3350A, FPZT7300, FPZT7350, FPZT7450, FPZT7550	3 Years
FP7100 Series Pressure Tanks, E100ELT, E3305TLT, E3375TLT, E5005TLT, E50TLT, E50VLT, E75STVT, E75VLT, FPSC3200A, FPSC3250A, FPSC4550A, FPSE9000	5 Years

General Terms and Conditions

You must pay all labor and shipping charges necessary to replace product covered by this warranty. This warranty does not apply to the following: (1) acts of God; (2) products which, in FLOTEC's sole judgment, have been subject to negligence, abuse, accident, misapplication, tampering, or alteration; (3) failures due to improper installation, operation, maintenance or storage; (4) atypical or unapproved application, use or service; (5) failures caused by corrosion, rust or other foreign materials in the system, or operation at pressures in excess of recommended maximums.

This warranty sets forth FLOTEC's sole obligation and purchaser's exclusive remedy for defective products.

FLOTEC SHALL NOT BE LIABLE FOR ANY CONSEQUENTIAL, INCIDENTAL, OR CONTINGENT DAMAGES WHATSOEVER.

THE FOREGOING LIMITED WARRANTIES ARE EXCLUSIVE AND IN LIEU OF ALL OTHER EXPRESS AND IMPLIED WARRANTIES, INCLUDING BUT NOT LIMITED TO IMPLIED WARRANTIES OF MERCHANTABILITY AND FITNESS FOR A PARTICULAR PURPOSE. THE FOREGOING LIMITED WARRANTIES SHALL NOT EXTEND BEYOND THE DURATION PROVIDED HEREIN.

Some states do not allow the exclusion or limitation of incidental or consequential damages or limitations on how long an implied warranty lasts, so the above limitations or exclusions may not apply to You. This warranty gives You specific legal rights and You may also have other rights which vary from state to state.

Air Volume Control – Designed to maintain the air charge in a standard water storage tank. Precharged tanks do not use an air volume control.

Atmospheric Pressure – A force exerted upon the Earth's surface by the weight of air extending to a height of 25 miles above the earth. At sea level, 14.7 pounds per square inch (PSI).

Black Water – Raw human sewage.

Centrifugal Force – The force created by a spinning or rotating impeller resulting in the movement of water outward from the center point. A pump uses an impeller to create centrifugal force.

Check Valve – Allows water to move in only one direction, which prevents water from returning to its source.

Convertible Jet Pump – For deep wells where pumping water levels are as far as 90 feet below the pump. Also easily converted for shallow wells where pumping water levels are no more than 25 feet below the pump. Jet packages must be purchased separately.

Cut-in Pressure Setting – The point at which the pressure switch turns the pump on.

Deep Well – Well with a depth to water greater than 25 feet.

Depth to Water – The vertical measurement from pump level down to the top of the water in your well.

Discharge Pressure – The amount of force or pressure of the water being discharged from the pump.

Dual-Voltage Motor – Pump motor that can be operated on 115 or 230 volt service by simply changing the internal motor leads located under the motor canopy to correspond with the power supply.

Effluent – Sewage or wastewater which has undergone some pre-treatment. Effluent water may contain small solids and/or stringy material (lint, hair, etc.). Effluent is generally defined as 3/4" solids or less.

Foot Valve – Installs on end of pump suction pipe to prevent water from draining back to source. Includes strainer to minimize suction of debris into pump.

GPH – Gallons per hour.

GPM – Gallons per minute.

Gray Water – Non-toilet household wastewater (sinks, showers, laundry, etc.) that is sometimes recycled, especially for use in gardening or for flushing toilets.

Head – A term used to define water pressure in vertical feet. Or a term representing the energy content of a liquid, expressed as the height of an equivalent vertical column of water. a. This is expressed in feet of head. b. This can apply to both sides of a pump: the suction side and discharge side. c. It is also used to express the total losses in a pumping system (Total Dynamic Head).

HP – Horsepower (size rating of motor).

Jet Package – Required for operation of convertible and deep well jet pumps.

Jet Pump – A centrifugal pump which requires a jet, either built-in or purchased separately, to help build additional water pressure.

Lift – Lift is essentially the distance water has to travel between your sump basin and the highest vertical point in the drainage pipe. The most common lift height is 10 feet.

Precharged Tank – A water storage tank precharged with air at factory featuring a vinyl bag to separate water from air which prevents waterlogging. This tank design provides greater drawdown than standard tanks. Precharged tanks do not require an air volume control. (See Water Storage Tank, Waterlogging, Tank Drawdown.)

Pressure – A force usually expressed in pounds per square inch (PSI).

Pressure Relief Valve – Required for all submersible pump and pressure boosting installations to prevent overpressurization of water storage tank and system piping that could develop from pressure switch malfunction.

Pressure Switch – The switch that automatically turns the pump on and off at specified pressures 30/50 PSI and 40/60 PSI. IMPORTANT! Always replace an old switch with a new switch with the same pressure settings.

30/50 pressure operation – Pressure switch turns pump on at 30 PSI, off at 50 PSI.

40/60 pressure operation – Pressure switch turns pump on at 40 PSI, off at 60 PSI.

Priming the Pump – The initial filling of a jet or centrifugal pump with water so that the air can be removed.

Pump Capacity – The amount of water a pump is capable of moving at a given pressure.

PSI – Pounds per square inch. A unit of water and air pressure measurement.

Self-Priming Pump – A centrifugal pump having the capability of dispersing a certain amount of air from its pump body, assuming the pump has been primed initially, when operating under a suction lift; to free itself of entrained gas without losing prime; and to continue normal pumping operation without attention.

Sewage – Raw wastewater from residential, commercial or industrial sites. Sewage from residential sites is generally defined as 2" solids.

Shallow Well – Well with a depth to water of 25 feet or less.

Sizing – Properly matching pump to application for best performance.

Standard Tank – A pressurized water storage tank where air comes in contact with water. Requires air volume control for proper operation.

Submersible Control Box – Installs aboveground. Contains electrical starting components for 3-wire submersible deep well pumps. 2-wire submersible deep well pumps do not use a control box.

Submersible Deep Well Pump – For use on wells where pump water levels are up to 400 feet below point of use. Pump is submerged underwater in well.

Suction Lift – See Depth to Water.

Sump Pump – An electric pump that is placed in the basement of a home and is used to remove water from the basement to outside the home.

Tank Drawdown/Drawdown – The amount of usable water available from a water storage tank between pump stops and starts.

Waterlogging – The absorption of air into water stored in a water storage tank, which greatly reduces the amount of usable water drawdown available from the tank.

Water Storage Tank – Stores air and water under pressure to provide for automatic pump operation and a source of water when pump is not running.

Well Diameter – Inside dimension of well casing.





For more than 30 years, Flotec® has been a leader in providing water system products to solve residential water management needs. Flotec offers a wide range of products from utility pumps to complete water systems. All Flotec products are designed for easy installation and are backed by industry-leading warranties.



www.flotecwater.com

293 Wright Street, Delavan, WI 53115

1-800-365-6832 fax: 1-800-526-3757

