

PARLEC
Measurably Better



PRECISION MODULAR BORING

PRECISE | REPEATABLE | FLEXIBLE | VALUE



HISTORY

- 1948 Parlec is established in Rochester N.Y., as a job shop specializing in the manufacturing of Sulky Hubs.
- 1973 Parlec begins producing and distributing the Numertap and Autofacer product lines.
- 1977 Parlec expands its product line with the introduction of Toolholders, which are sold as Numertap and Autofacer accessories.
- 1980 The first Parsetter TMM[®] is produced.
- 1985 Parlec builds a new 42,000 square-foot, state-of-the-art manufacturing facility just outside of Rochester in Fairport, N.Y.
- 1992 Parlec begins to manufacture and distribute its own line of Boring Tools.
- 1997 Parlec becomes ISO 9001 certified. Parlec's sales triple from 1992-1997.
- 1998 Parlec further enhances its product line to include Workholding. Construction of a 58,000 square-foot plant addition begins.
- 2003 Parlec enters the Asian market with the opening of a sales and service office in Nanjing China.
- 2004 Parlec acquires Bristol Tool. Driven and static tools are added to Parlec's extensive product line. A new sales, engineering and distribution facility opens in Bristol, England.
- 2006 Parlec continues to expand its world wide footprint by opening a Wholly Owned Foreign Enterprise in Nanjing. This gives the company full sales, engineering, customer support and distribution capabilities on 3 continents.
- 2009 Sales offices are opened in Tianjin, Xian, Wuxi, and Chengdu to expand the China presence.
- 2010 Parlec partners with Gerardi for distribution of Driven & Static Tooling in Europe. Parlec begins distribution of Right angle heads in China.
- 2012 Parlec successfully completes a \$5 million dollar capital investment campaign to automate and expand its manufacturing capabilities in the United States.
- 2014 Parlec partners with TDM Systems.

Tool Machining Solutions



Tool Presetting, Measuring and Inspection Systems



Widest Range of Rigid, Tension and Compression Tapping



Precision Modular Boring Systems



Toolholding Production and High Performance Solutions



Quality, Precision, Innovation

PARLEC

TABLE OF CONTENTS

Selection Guide	6
New Boring Features and Benefits	7
Selection Guide	9
Quotation Request Sheet	10
Modular Shanks.....	12
BT Shanks	12
V Flange Shanks.....	13
HSK Shanks.....	14
NMTB Shanks, Straight Shanks, & Heavy Metal Ext.	15
Modular Components	16
Extensions & Reductions.....	16
Collet Chucks, End Mill & Shell Mill Holders.....	17
Twin Bore Roughing System	18
Twin Bore Roughing .95" to 6.00" (25 mm to 152.4 mm).....	18
Insert Holders.....	19
Components	20
Roughing Speeds, Feed Rates & Machining Allowance	21
Adjusting for Balanced Cutting	22
Adjusting for Stepped Cutting	23
Small Diameter Boring	24
Small Diameter Balanced Boring Tools	24
Balanced Modular Boring Bars.....	25
Bars & Bushings, .078" (2 mm to 11 mm).....	26
Boring Tool Kit	27
Operating Instructions.....	28
Application Guide.....	29
Precision Finish Boring System.....	30
Series 3 Precision Inch Finish Heads.....	30
Series 3 Precision Inch Finish Heads, Insert Holders	31
Operating Instructions	32
Finish Boring Speeds.....	34
Finish Boring Feeds.....	35

TABLE OF CONTENTS

Large Diameter Boring System.....	36
Large Diameter Tree.....	36
Extension Base Coupler.....	37
Extension Bases.....	38
Range Extension Slide and Riser.....	39
Rough Boring Holder Base.....	40
Finish Boring Unit.....	41
Insert Selection Guide.....	42
Inserts Information.....	42
Insert Carbide Grades.....	44
Inserts.....	46
Diamond Inserts.....	46
Triangular Inserts.....	47
Trigon/Square Inserts.....	48
Precision Finish Boring Legacy System.....	49
Series 2 Replacement Insert Holder.....	49
Insert Holder Blanks Series 2, Finish Head Components.....	50
Large Diameter Legacy System.....	51
Extension Bases.....	51
Ring Holders and Boring Heads.....	52
Retention Knobs.....	54
ANSI/ISO and DIN.....	55
MAS BT.....	56
Quotation Request Sheet.....	57





NEW boring features bring NEW benefits!

Parlec is creating new standards for the precision boring industry!

In addition a full-range of boring capabilities, modular designs, and unmatched repeatable precision, Parlec is now providing new and enhanced features that will change the way you machine for good!

SMALL DIAMETER BORING SYSTEM

- Boring bar receiver telescopes to minimize overhang.
- Balanced Modular Boring Bars and Noses available as standard combined with the balanceable head for extreme high velocity boring.

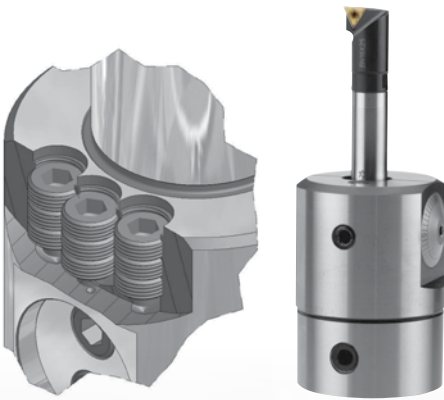

NEW



.001"



.02MM

A .0001" (.002mm) Vernier is standard on all finish heads eliminating the need to purchase expensive heads

PRECISION FINISH BORING SYSTEM

NEW

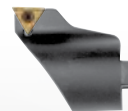
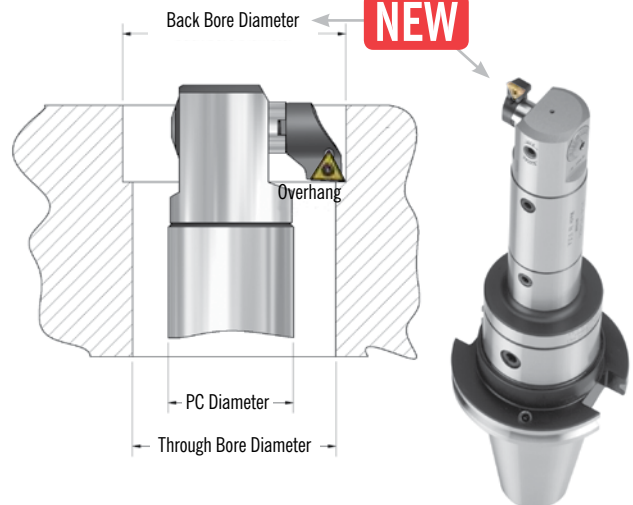

Extended length insert holders allow expansion of the boring range

THE PC CONNECTION

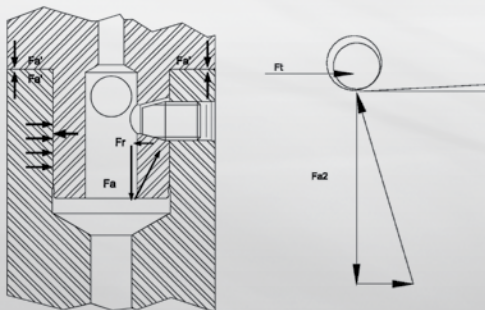

Rigidity

- Created by Force - The face to face clamping forces are equal to the axial force F_a . Precision .0002" on Diameter.
- Orientation - The cross pin orientates the PC screw and transmits extreme forces.

Self Tightening

- The torsional cutting forces are primarily transmitted by the friction between the mating faces.
- Any remaining torque will result in an additional wedge action between the locking screw and inner member.
- Due to the very small resulting wedge angle, any increased torsional force (F_t) will be transformed into a very strong axial clamping force (F_{a2}).



NEW UNIQUE COOLANT DELIVERY → DIRECTED TO THE CUTTING EDGE!

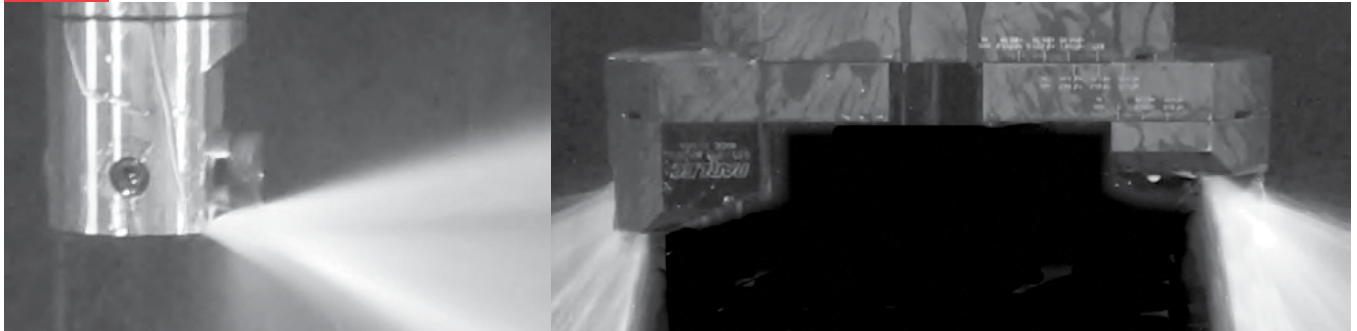

Tool life and chip form are maximized by directed high pressure coolant

TWIN BORE FOR HEAVY METAL REMOVAL RATES

NEW Individually and easily adjusted cutting tips allow for balanced or step cutting from .95" (24 mm) to over 23" (600 mm) resulting in maximum metal removal rates.

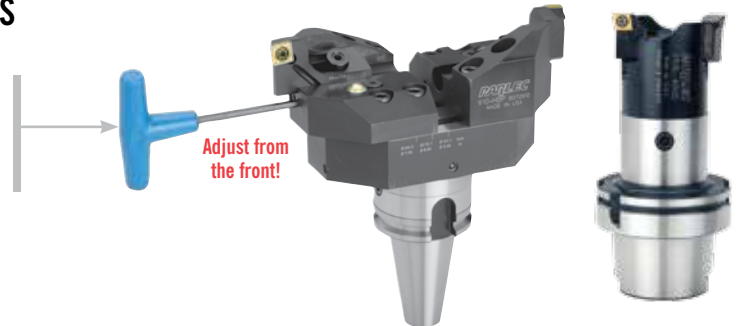

LARGE DIAMETER BORING SYSTEM

NEW Inverted assembly allows system to be used to bore OD's utilizing twin bore or precision finish.

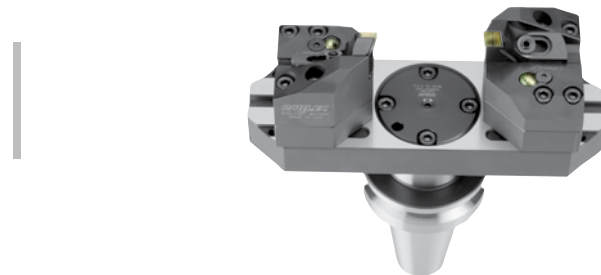

NEW Precision counter balanced finish boring system for large diameters. Large .0005" (.02 mm) dial makes easy and accurate diameter adjustments.

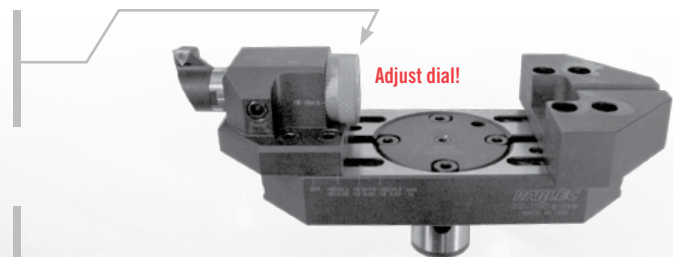

NEW PC Extension Base Couplers connect the slide directly to the shank eliminating an extra connection. The system allows a tool tip setup of 0°, 45° or 90° for tool carousel clearance.

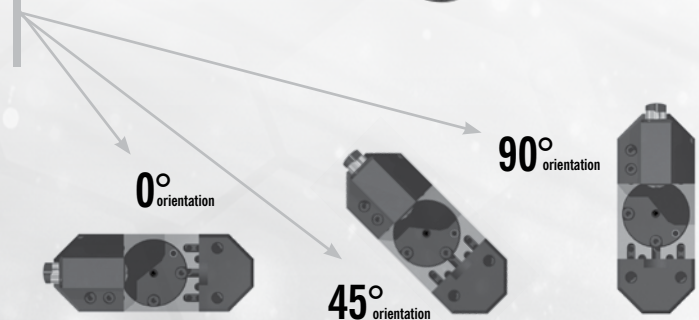

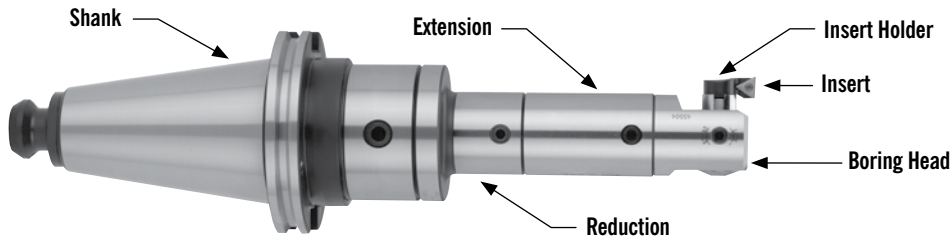

The force F_r is created by tightening the PC screw. This results in line contact seating with high repeatable precision (.0002" on diameter). The geometry of the screw and mating hole in the male pilot creates the resultant force F_a .

$$F_a = 3.7 \times F_r$$

The face to face clamping forces $F_{a'}$ are equal to the axial force F_a .

The torsional cutting forces are primarily transmitted by the friction between the mating faces. Any remaining torque will result in an additional wedge action between the locking screw and the inner member. Due to the very small resulting wedge angle any increased torsional force F_t will be transformed into a very strong axial clamping force F_{a2} .

The cross pin (not shown) helps in alignment of the PC screw and prevents over tightening under heavy torsional loads.

CONNECTION DIAMETER

PC Size	Diameter"	MM
PC2	.94	24
PC3	1.22	31
PC4	1.54	39
PC5	1.97	50
PC6	2.52	64
PC7	3.54	90

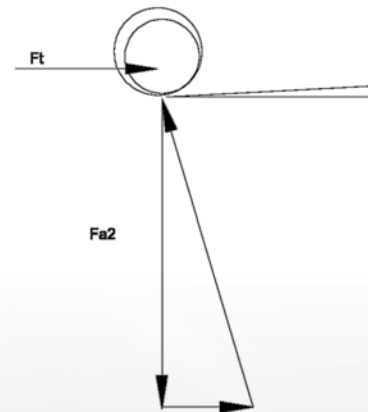
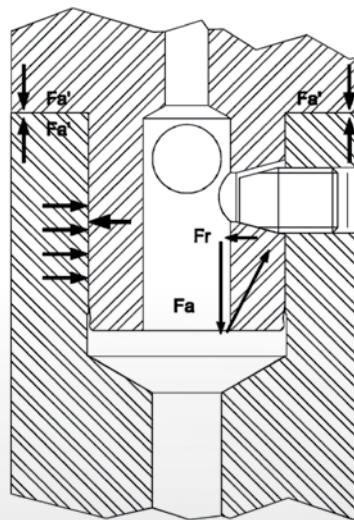

PC SCREWS

Part Number	Connection Size	Wrench	Tightening Torque
880-002	PC2	018-102	25 in. lbs.
880-003	PC3	018-103	42 in. lbs.
880-004	PC4	018-104	84 in. lbs.
880-005	PC5	018-105	168 in. lbs.
880-006	PC6	018-106	336 in. lbs.
880-007	PC7	018-107	840 in. lbs.



PC Screw 880-006 shown here.

Quotation Request Sheet

BORING



Selection Guide

9

CONTACT INFORMATION For quick response, just photocopy this page, complete all information (please include Part Print where appropriate) and simply FAX back to Parlec at 1-800-866-5917

Company _____

Contact Name _____ Title _____

Business Address _____ City _____ State _____ Zip _____

Phone _____ Fax _____ Email _____

BORING RANGE: .078"-23.80" (2-605MM)

A Finish Bore Diameter	A Finish Bore Tolerance	B Starting Diameter	C Gage Length	D Access Length	E Bore Depth	F Access Diameter

Workpiece Material _____ Shank Size & Type _____

Hardness _____ Machine Tool Make _____

Machine Tool Model _____

RMS

Interrupted Cut Through-Holes Bottom-Holes

COOLANT

Through-Spindle Flange Entry Flood

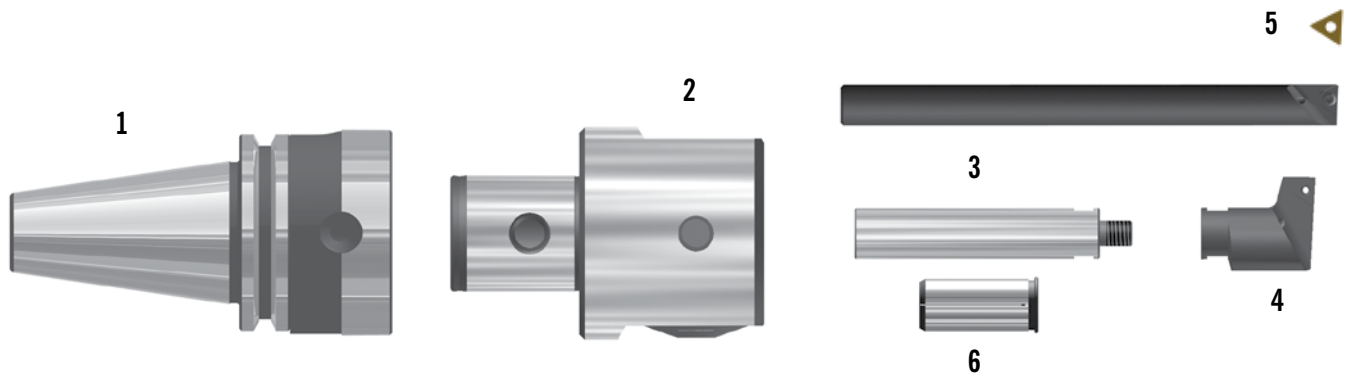

.078" - 1.89" (2-48MM) SMALL DIAMETER BORING RANGE TREE

Component	Selection Criteria	Catalog Page	
1	Modular Shank	Machine tool taper and projection requirement	Page 12–15
2	Small Diameter Finish Head	Telescoping bar and balance capability make is the right choice for boring small diameters	Page 24
3	Boring Bar	Available as modular or solid for smaller diameters. Steel and Carbide with coolant through standard on all modular style.	Page 25
3	Boring Bar	Solid design for smaller diameters	Page 26
4	Modular Boring Noses	Allows the diameter to be extended with less expense in boring bars. All noses are balanced and coolant through	Page 25
5	Inserts	Select based on geometry of insert holder, material of bore and radius	Page 42–48
6	Reduction Bushing	Select to reduce the bore through receiver to the appropriate size boring bar	Page 24, 26

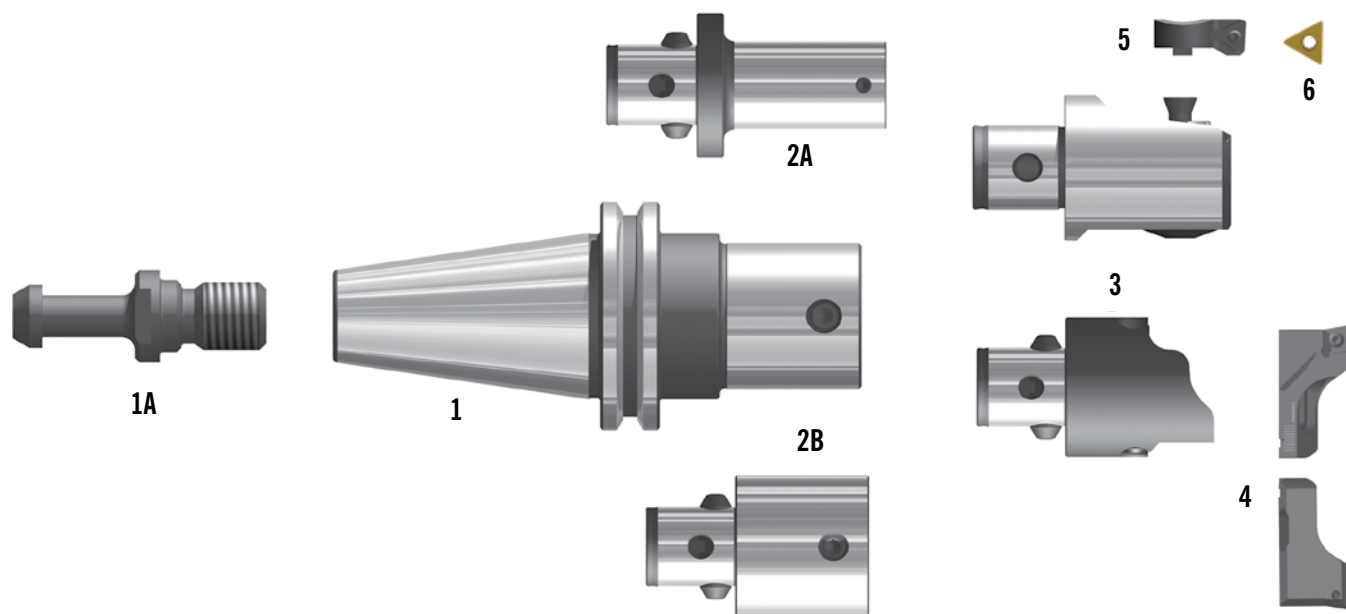

.98” - 6.00” (25-152.4MM) ROUGH AND FINISH BORING RANGE TREE

Component	Selection Criteria	Catalog Page	
1	Modular Shank	Machine tool taper and projection requirement	Page 12–15
1A	Retention Knob	Machine tool specific	Page 54–57
2A	Extension	Used to extend the reach of a boring assembly	Page 16
2B	Reduction	Used to extend the length to diameter ratio when reach and not clearance is the issue	Page 16
3	Twin Rough Boring Head	Select when metal removal is the goal and bore tolerance is larger. Setting on a presetter will provide accurate bore but adjustment for insert wear is not easily done at the machine.	Page 20
3	Precision Finish Head	Select when much less material removal is required, such as after roughing, and precision and ease of adjustment are the main critical requirement.	Page 30–31
4	Twin Bore Insert Holder (pair)	Select by bore configuration and size.	Page 19
5	Precision Finish Insert Holder	Select by bore size, use size 1 for maximum bar rigidity	Page 31
6	Inserts	Select based on geometry of insert holder, material of bore and radius	Page 42–48



B40-PC6-4 shown here.
Also available with AD/B coolant.

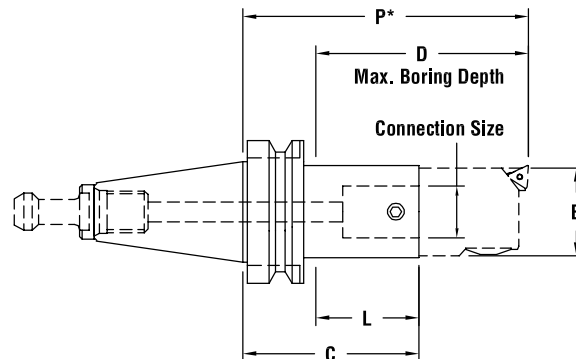

Order Retention Knob separately
(see pages 54–57).

30 TAPER

Part Number	Connection Size	B" (mm)	C" (mm)	D" (mm)	L" (mm)	P** (mm)	Weight lbs. (kg)
B30-PC4-2	PC4	1.54 (39)	1.75 (44.5)	2.24 (57)	0.76 (19.3)	3.60 (91.5)	1. (2.2)

40 TAPER

Part Number	Connection Size	B" (mm)	C" (mm)	D" (mm)	L" (mm)	P** (mm)	Weight lbs. (kg)
B40-PC2-4	PC2	.94 (24)	3.80 (96.5)	4.12 (104.6)	2.64 (67)	5.28 (134.1)	2.5 (1.1)
B40-PC3-4	PC3	1.22 (31)	3.70 (94)	4.15 (105.4)	2.54 (64.5)	5.31 (135)	2.6 (1.2)
B40-PC3-5	PC3	1.22 (31)	4.80 (122)	5.25 (133.3)	3.64 (92.5)	6.41 (163)	3.2 (1.5)
B40-PC4-3	PC4	1.54 (39)	2.56 (65)	3.25 (82.5)	1.40 (35.5)	4.41 (112)	2.8 (1.3)
B40-PC4-5	PC4	1.54 (39)	4.53 (115)	5.21 (132.3)	3.36 (85.4)	6.38 (162)	3.6 (1.6)
B40-PC5-3	PC5	1.97 (50)	2.16 (55)	3.24 (82.3)	1.00 (25.4)	4.40 (112)	2.8 (1.3)
B40-PC5-6	PC5	1.97 (50)	5.31 (135)	6.37 (162)	4.13 (105)	7.55 (192)	5.8 (2.7)
B40-PC6-4	PC6	2.52 (64)	2.40 (61)	3.91 (99.3)	1.12 (28.5)	5.19 (132)	3.1 (1.4)
B40-PC6-6	PC6	2.52 (64)	4.76 (121)	6.43 (163)	3.64 (92.5)	7.55 (192)	6.5 (3)

50 TAPER

Part Number	Connection Size	B" (mm)	C" (mm)	D" (mm)	L" (mm)	P** (mm)	Weight lbs. (kg)
B50-PC2-4	PC2	.94 (24)	4.15 (105.4)	4.03 (102.4)	2.54 (64.5)	5.63 (143)	7.7 (3.5)
B50-PC2-5	PC2	0.94 (24)	4.98 (126.5)	4.84 (123)	3.36 (85.3)	6.46 (164)	9.1 (4.2)
B50-PC3-4	PC3	1.22 (31)	4.00 (101.6)	4.03 (102.4)	2.40 (61)	5.63 (143)	7.7 (3.5)
B50-PC3-6	PC3	1.22 (31)	5.98 (152)	5.97 (151.6)	4.36 (110.8)	7.49 (190)	9.8 (4.5)
B50-PC4-4	PC4	1.54 (39)	3.78 (96)	4.03 (102.4)	2.18 (55.4)	5.63 (143)	8.1 (3.7)
B50-PC4-6	PC4	1.54 (39)	6.14 (156)	6.37 (161.8)	4.52 (114.8)	7.99 (203)	10.5 (4.8)
B50-PC4-8	PC4	1.54 (39)	7.28 (185)	7.51 (190.7)	5.66 (143.8)	9.13 (232)	11 (5)
B50-PC5-4	PC5	1.97 (50)	3.38 (86)	4.03 (102.4)	1.79 (45.5)	5.63 (143)	8.1 (3.7)
B50-PC5-8	PC5	1.97 (50)	6.89 (175)	7.51 (190.7)	5.27 (134)	9.13 (232)	12.2 (5.6)
B50-PC5-10	PC5	1.97 (50)	9.25 (235)	9.87 (250)	7.63 (194)	11.49 (292)	14.2 (6.5)
B50-PC6-4	PC6	2.52 (64)	2.84 (72)	4.03 (102.4)	1.24 (31.5)	5.63 (143)	8.8 (4)
B50-PC6-6	PC6	2.52 (64)	5.19 (132)	6.36 (161.5)	3.47 (88)	7.98 (202.7)	12.2 (5.6)
B50-PC6-8	PC6	2.52 (64)	6.34 (161)	7.51 (190.7)	4.72 (120)	9.13 (232)	13.7 (6.2)
B50-PC6-10	PC6	2.52 (64)	9.00 (228.6)	10.19 (259)	7.40 (188)	11.79 (300)	15.8 (7.2)
B50-PC6-12	PC6	2.52 (64)	11.06 (281)	12.23 (310.6)	9.44 (240)	13.85 (352)	21.2 (9.7)

*Compute "P" dimensions by adding "C" dimensions of all components used. Maximum bore depth "D" may be increased by using extension adapters.

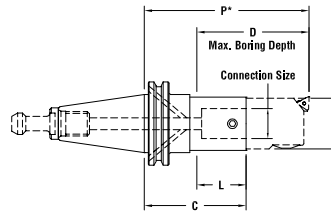

Order Retention Knob separately
(See pages 54–57).

40 TAPER

Part Number	Part Number with Flange Coolant***	Connection Size	B" (mm)	C" (mm)	D" (mm)	L" (mm)	P*" (mm)	Weight lbs. (kg)
C40-PC2-2	-	PC2	.944 (24)	2.07 (52.6)	2.00 (50.8)	.56 (14.2)	3.54 (90)	2.4 (1.1)
C40-PC2-3	-	PC2	.944 (24)	3.33 (84.6)	3.15 (80)	1.95 (49.5)	4.80 (122)	2.5 (1.1)
C40-PC2-4	-	PC2	.944 (24)	4.11 (104.5)	3.94 (100)	2.74 (69)	5.59 (142)	2.6 (1.2)
C40-PC3-3	-	PC3	1.22 (31)	3.15 (80)	3.20 (81.3)	1.78 (45.2)	4.76 (121)	2.6 (1.2)
C40-PC3-5	-	PC3	1.22 (31)	5.12 (130)	5.57 (141.5)	3.74 (95)	6.73 (171)	3.3 (1.5)
C40-PC4-1	-	PC4	1.75 (44.5)	1.38 (35)	1.75 (44.5)	-	3.23 (82)	2.2 (1)
C40-PC4-3	C40B-PC4-3	PC4	1.54 (39)	2.87 (73)	3.15 (80)	1.50 (38.1)	4.72 (120)	2.7 (1.2)
C40-PC4-6	-	PC4	1.54 (39)	6.02 (153)	6.30 (160)	4.26 (108.2)	7.87 (200)	4.3 (2.0)
C40-PC5-3	-	PC5	1.97 (50)	2.48 (63)	3.15 (80)	1.11 (28.2)	4.72 (120)	2.8 (1.3)
C40-PC5-6	-	PC5	1.97 (50)	5.63 (143)	6.30 (160)	4.26 (108.2)	7.87 (200)	5.5 (2.5)
C40-PC6-3**	C40B-PC6-3	PC6	2.52 (64)	2.00 (50.8)	3.42 (87)	.63 (16)	4.80 (122)	3.1 (1.4)
C40-PC6-4	C40B-PC6-4	PC6	2.52 (64)	2.72 (69)	3.94 (100)	1.34 (8.6)	5.51 (140)	3.3 (1.5)
C40-PC6-6	-	PC6	2.52 (64)	5.08 (129)	6.30 (160)	3.70 (94)	7.87 (200)	6.3 (2.9)

50 TAPER

Part Number	Part Number with Flange Coolant***	Connection Size	B" (mm)	C" (mm)	D" (mm)	L" (mm)	P*" (mm)	Weight lbs. (kg)
C50-PC2-2	-	PC2	.94 (24)	2.07 (52.6)	2.00 (50.8)	.56 (14.2)	3.54 (90)	7.0 (3.2)
C50-PC2-4	-	PC2	.94 (24)	4.11 (104.5)	3.94 (100)	2.74 (69)	5.59 (142)	7.0 (3.2)
C50-PC2-5	-	PC2	.94 (24)	5.29 (134.4)	5.12 (130)	3.92 (99.5)	6.77 (122)	7.3 (3.3)
C50-PC3-4	-	PC3	1.22 (31)	3.94 (100)	4.39 (111.5)	2.56 (65)	5.55 (141)	7.7 (3.5)
C50-PC3-5	-	PC3	1.22 (31)	5.12 (130)	5.57 (141.5)	3.74 (95)	6.73 (171)	7.7 (3.5)
C50-PC3-6	-	PC3	1.22 (31)	6.30 (160)	6.13 (155.7)	4.30 (109)	7.91 (201)	8.1 (3.7)
C50-PC4-4	C50B-PC4-4	PC4	1.54 (39)	3.61 (91.7)	3.94 (100)	2.24 (57)	5.46 (139)	7.6 (3.5)
C50-PC4-6	-	PC4	1.54 (39)	6.02 (153)	6.30 (160)	4.65 (118)	7.87 (200)	8.7 (4)
C50-PC4-8	-	PC4	1.54 (39)	7.60 (193)	7.88 (200)	6.22 (158)	9.45 (240)	9.5 (4.3)
C50-PC5-4	-	PC5	1.97 (50)	3.27 (83)	3.94 (100)	1.89 (48)	5.51 (140)	7.8 (3.5)
C50-PC5-6	-	PC5	1.97 (50)	5.63 (143)	6.30 (160)	4.26 (108.2)	7.87 (200)	9.7 (4.3)
C50-PC5-8	-	PC5	1.97 (50)	7.20 (183)	7.88 (200)	5.83 (148)	9.45 (240)	10.9 (5)
C50-PC5-10	-	PC5	1.97 (50)	9.57 (243)	10.24 (260)	8.19 (208)	11.81 (300)	12.8 (5.8)
C50-PC6-4	C50B-PC6-4	PC6	2.52 (64)	2.72 (69)	3.94 (100)	1.34 (34)	5.51 (140)	7.7 (3.5)
C50-PC6-6	-	PC6	2.52 (64)	5.08 (129)	6.30 (160)	3.70 (94)	7.87 (200)	10.8 (4.9)
C50-PC6-8	-	PC6	2.52 (64)	6.65 (169)	7.88 (200)	5.28 (134)	9.45 (240)	12.8 (5.8)
C50-PC6-10	-	PC6	2.52 (64)	9.02 (229)	10.24 (260)	7.64 (194)	11.81 (300)	15.9 (7.2)
C50-PC6-12	-	PC6	2.52 (64)	11.38 (289)	12.60 (320)	10.00 (254)	14.17 (360)	19.1 (8.7)
C50-PC7-6	-	PC7	3.54 (90)	3.27 (83)	6.30 (160)	1.89 (48)	7.87 (200)	10.0 (4.6)
C50-PC7-8	-	PC7	3.54 (90)	5.27 (134)	8.30 (210)	3.89 (99)	9.87 (251)	15.3 (7)
C50-PC7-10	-	PC7	3.54 (90)	7.20 (183)	10.24 (260)	5.83 (148)	11.81 (300)	20.3 (9.2)

60 TAPER

Part Number	Connection Size	B" (mm)	C" (mm)	D" (mm)	L" (mm)	P*" (mm)	Weight lbs. (kg)
C60-PC6-4	PC6	2.52 (64)	3.10 (78.8)	4.20 (106.7)	1.60 (40.6)	5.90 (150)	22.6 (10.3)
C60-PC6-12	PC6	2.52 (64)	11.10 (282)	12.20 (310)	9.60 (244)	13.90 (353)	34.0 (15.5)
C60-PC7-10	PC7	3.54 (90)	7.30 (185.4)	10.22 (260)	5.80 (147.3)	11.91 (303)	35.2 (16)

* Compute "P" dimensions by adding "C" dimensions of all components used. Maximum bore depth "D" may be increased by using extension adapters. ** Deviates from ANSI B5.50 1994 - No clearance for some tool changers. *** Other sizes available on request.



H100A-PC6-4 shown here.

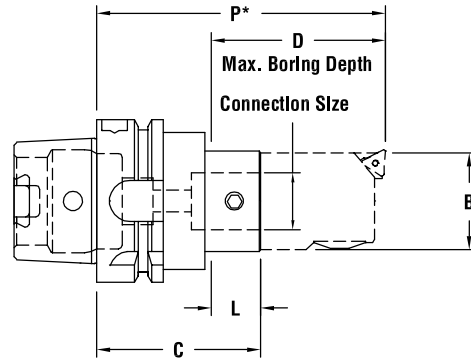

HSK 63A

Part Number	Connection Size	B" (mm)	C" (mm)	D" (mm)	L" (mm)	P** (mm)	Weight lbs. (kg)
H63A-PC2-73	PC2	.94 (24)	3.52 (89.5)	3.74 (95)	2.26 (57.5)	5.00 (127)	2.0 (.9)
H63A-PC3-103	PC3	1.22 (31)	3.94 (100)	4.29 (109)	2.68 (68)	5.55 (141)	2.2 (1)
H63A-PC4-65	PC4	1.54 (39)	2.50 (63.5)	3.09 (78.5)	1.24 (31.5)	4.35 (110.5)	2.3 (1)
H63A-PC4-178	PC4	1.54 (39)	6.00 (152.4)	6.59 (167.4)	4.74 (120.4)	7.85 (199.4)	4.0 (1.9)
H63A-PC5-105	PC5	1.97 (50)	3.26 (83)	4.25 (108)	2.01 (51)	5.50 (140)	3.1 (1.4)
H63A-PC6-100	PC6	2.52 (64)	3.25 (82.3)	4.78 (121.5)	1.99 (50.5)	6.04 (153.5)	3.4 (1.5)
H63A-PC6-147	PC6	2.52 (64)	5.13 (130)	6.65 (169)	3.86 (98)	7.92 (201)	6.0 (2.8)

HSK 100A

Part Number	Connection Size	B" (mm)	C" (mm)	D" (mm)	L" (mm)	P** (mm)	Weight lbs. (kg)
H100A-PC2-107	PC2	.94 (24)	4.51 (114.5)	4.61 (117)	3.13 (74.5)	5.98 (152)	2.0 (.9)
H100A-PC3-122	PC3	1.22 (31)	4.92 (125)	5.16 (131)	3.54 (90)	6.53 (166)	6.4 (2.9)
H100A-PC4-65	PC4	1.54 (39)	2.50 (63.5)	2.97 (75.5)	1.12 (28.5)	4.35 (110.5)	6.2 (2.8)
H100A-PC4-182	PC4	1.54 (39)	7.00 (178)	7.48 (190)	5.63 (143)	8.85 (225)	8.4 (3.8)
H100A-PC5-122	PC5	1.97 (50)	4.25 (108)	5.12 (130)	2.87 (73)	6.49 (165)	7.7 (3.5)
H100A-PC6-100	PC6	2.52 (64)	3.25 (82.5)	4.67 (118.5)	1.87 (47.5)	6.04 (153.5)	7.2 (3.3)
H100A-PC6-190	PC6	2.52 (64)	6.69 (170)	8.11 (206)	5.31 (135)	9.48 (241)	11.9 (5.4)

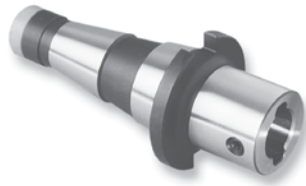

N40-PC4-3 shown here.
Other NMTB sizes available on request.

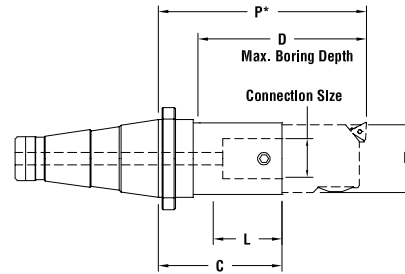

40 TAPER

Part Number	Connection Size	B	C	D	L	P*	Weight lbs. (kg)
N40-PC4-3	PC4	1.54	1.93	3.20	1.35	3.78	2.1 (.95)
N40-PC6-4	PC6	2.52	2.17	4.14	1.34	4.97	6.4 (2.9)

50 TAPER

Part Number	Connection Size	B	C	D	L	P*	Weight lbs. (kg)
N50-PC4-6	PC4	1.54	5.24	6.30	4.45	7.09	7.6 (3.5)
N50-PC6-4	PC6	2.52	1.93	3.94	1.15	4.72	6.4 (2.9)
N50-PC6-12	PC6	2.52	10.59	12.60	9.81	13.38	17.8 (8.1)
N50-PC7-6	PC7	3.54	2.48	5.87	1.26	7.09	8.1 (3.7)

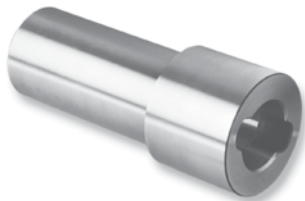

S20-PC6-4 shown here.

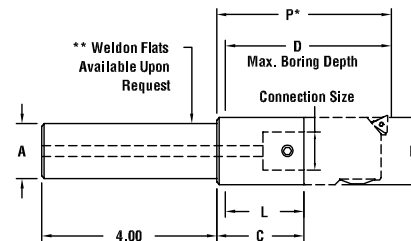

STRAIGHT SHANKS

Part Number	Connection Size	A	B	C	D	L	P*	Weight lbs. (kg)
S12-PC4-3	PC4	1.25	1.54	2.00	3.75	1.90	3.85	2.0 (.9)
S20-PC4-3	PC4	2.00	1.54	2.00	3.75	1.90	3.85	4.2 (1.9)
S12-PC6-4	PC6	1.25	2.52	2.00	4.70	1.90	4.80	3.1 (1.4)
S20-PC6-4	PC6	2.00	2.52	2.00	4.70	1.90	4.80	5.2 (2.4)

Maximum bore depth "D" may be increased by using extension adapters.

*Compute "P" dimensions by adding "C" dimensions of all components used.

**For Weldon flats, add "W" after SXX, i.e., S12W-PC4-3. Other shank configurations available on request.



PC4-150HM15 shown here.

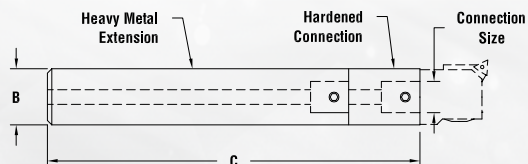

HEAVY METAL EXTENSIONS

Part Number	Connection Size	B	C	Weight lbs. (kg)
PC2-094HM11	PC2	.937	11.42	3.9 (1.8)
PC3-125HM14	PC3	1.250	13.78	9.0 (4.0)
PC4-150HM15	PC4	1.500	14.75	13.0 (5.9)

*Not recommended for use on lathes with twin bore units. Consult Parlec's Applications department.



EXTENSIONS



PC4-PC4E1
shown here.

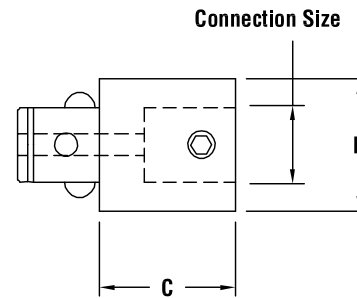

EXTENSIONS

Part Number	Connection Size	B" (mm)	C" (mm)	Weight lbs. (kg)
PC2-PC2E1	PC2	.94 (24)	1.18 (30)	.3 (.2)
PC2-PC2E2	PC2	.94 (24)	1.77 (45)	.4 (.2)
PC3-PC3E1	PC3	1.22 (31)	1.18 (30)	.4 (.2)
PC3-PC3E2	PC3	1.22 (31)	1.77 (45)	.5 (.3)
PC4-PC4E1	PC4	1.54 (39)	1.57 (40)	.8 (.4)
PC4-PC4E2	PC4	1.54 (39)	2.36 (60)	1.1 (.5)
PC5-PC5E2	PC5	1.97 (50)	2.36 (60)	1.9 (.9)
PC5-PC5E3	PC5	1.97 (50)	3.54 (90)	2.8 (1.3)
PC6-PC6E2	PC6	2.52 (64)	2.36 (60)	3.0 (1.4)
PC6-PC6E4	PC6	2.52 (64)	3.94 (100)	5.0 (2.3)
PC7-PC7E4	PC7	3.54 (90)	3.94 (100)	9.9 (4.5)
PC7-PC7E6	PC7	3.54 (90)	6.30 (160)	17.0 (7.73)

REDUCTIONS



PC4-PC2R2
shown here.

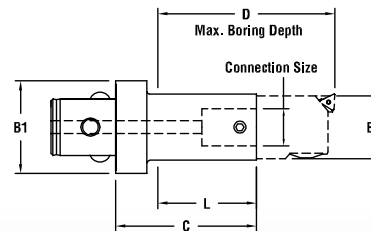

REDUCTIONS

Part Number	A (Connection)	E (Connection)	B1	B2	C" (mm)	D" (mm)	L (Max.)	Weight lbs. (kg)
PC3-PC2R1	PC3	PC2	1.22	.945	1.36 (34.5)	2.36 (60)	.965	.4 (.2)
PC4-PC2R2	PC4	PC2	1.54	.945	2.03 (51.5)	2.95 (75)	1.56	.6 (.3)
PC4-PC3R2	PC4	PC3	1.54	1.220	1.85 (47)	2.95 (75)	1.38	1.0 (.5)
PC5-PC2R3	PC5	PC2	1.97	.945	3.21 (81.5)	3.94 (100)	2.54	1.1 (.5)
PC5-PC3R3	PC5	PC3	1.97	1.220	3.03 (77)	3.94 (100)	2.36	1.3 (.6)
PC5-PC4R2	PC5	PC4	1.97	1.535	2.76 (70)	3.94 (100)	2.09	1.6 (.8)
PC6-PC2R3	PC6	PC2	2.52	.945	3.76 (95.5)	4.53 (115)	3.13	1.8 (.9)
PC6-PC3R3	PC6	PC3	2.52	1.220	3.58 (91)	4.53 (115)	2.95	2.1 (1)
PC6-PC3R5	PC6	PC3	2.52	1.220	5.35 (136)	6.30 (160)	4.72	2.6 (1.2)
PC6-PC4R1	PC6	PC4	2.52	1.535	1.93 (49)	3.15 (80)	1.30	1.7 (.8)
PC6-PC4R3	PC6	PC4	2.52	1.535	3.31 (84)	4.53 (115)	2.68	1.3 (.6)
PC6-PC4R5	PC6	PC4	2.52	1.535	5.08 (129)	6.30 (160)	4.45	3.0 (1.4)
PC6-PC5R3	PC6	PC5	2.52	1.969	2.91 (74)	4.53 (115)	2.28	2.8 (1.3)
PC7-PC6R4	PC7	PC6	3.54	2.52	4.18 (106)	6.30 (160)	3.50	7.0 (3.2)



MODULAR COLLET CHUCK

Part Number	Connection Size	Nut style	B	C	D	Screw Stop
PC4-16ER3	PC4	ER FLUSH	1.11	3.13	3.13	BS-20
PC4-16ER325	PC4	ER POWER	1.11	3.25	3.25	BS-20
PC4-18DC2	PC4	DA 180	1.44	2.28	2.28	-
PC4-20ER325	PC4	ER POWER	1.34	3.25	3.25	BS-09
PC4-25ER325	PC4	ER POWER	1.67	3.25	3.25	BS-11
PC4-32ER325	PC4	ER POWER	1.97	3.25	3.25	BS-18
PC6-10SC3	PC6	PG 100	2.44	3.25	3.25	BS-18
PC6-18DC2	PC6	DA 180	1.44	3.43	3.43	BS-18
PC6-20ER340	PC6	ER FLUSH	1.34	3.40	3.40	BS-09
PC6-32ER340	PC6	ER FLUSH	1.97	3.40	3.40	BS-18

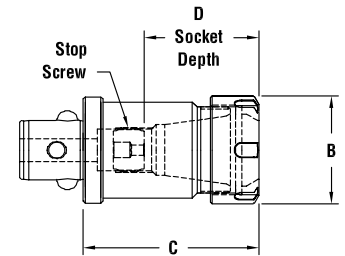

MODULAR END MILL HOLDERS

Part Number	Connection Size	A SIZE	B	C	D	E	F
PC4-75EM3	PC4	.750	1.75	3.13	2.75	1.00	-
PC6-75EM3	PC6	.750	1.75	3.03	2.75	1.00	-
PC6-10EM3	PC6	1.000	2.00	3.28	2.75	1.00	1.12
PC6-12EM3	PC6	1.250	2.50	3.28	2.75	1.00	1.12

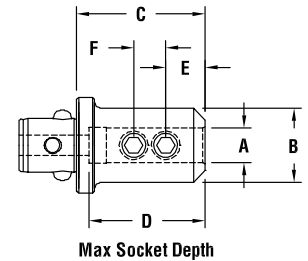

MODULAR SHELL MILL HOLDERS

Part Number	Connection Size	A SIZE	B	C	G	Drive Key	Thread
PC4-75SM1	PC4	.750	1.75	0.78	0.69	0.31	3/8 - 24
PC6-75SM1	PC6	.750	2.52	0.78	0.69	0.31	3/8 - 24
PC6-10SM1	PC6	1.000	2.52	0.78	0.69	0.38	1/2 - 20
PC6-12SM1	PC6	1.250	2.75	1.03	0.69	0.50	5/8 - 18
PC6-15SM2	PC6	1.500	3.75	1.53	0.94	0.62	3/4 - 16

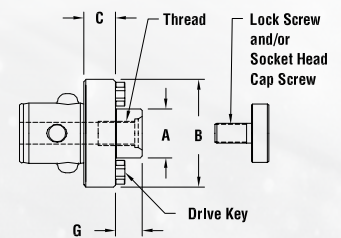



PC4-4405 shown here with insert holders and inserts.

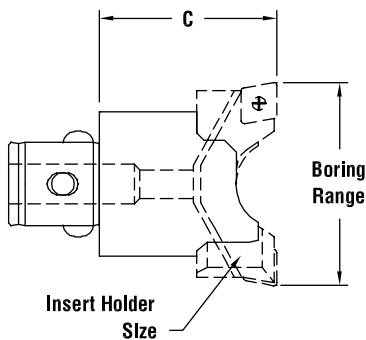

- Independent height and diameter setting permits balanced cutting with production of almost perfectly round holes from the beginning, irrespective of core shifts.
- Two height balanceable cutting edges results in metal removal at rates almost 4 times that of a single cutter.
- Height adjustments are made with a cam that supports the insert holder where needed, at the furthest radial point.
- Each insert holder can be adjusted individually in diameter with a dial screw for fast, easy set-up operations.
- Balanced or stepped cutting can be done with the same set of insert holders permitting heavy stock removal and eliminating the need to purchase two sets of insert holders.
- Standard through-spindle coolant capability cools the insert and flushes chips.
- ISO standard inserts - requires no special expensive inserts.
- Square SCMT insert holders with 6° lead for through hole boring or extreme core shifts.
- Diamond CCMT insert holders for boring to a square holder, or deep bore lengths.
- Trigon WCMT insert holders for applications requiring heavy stock removal.

TWIN BORE ROUGHING

Part Number	Bore Range Min.	Bore Range Max.	Connection Size	Insert Holder Size	Body Diameter	C	Weight lbs. (kg)
PC2-4205	.95 (24.1)	1.31 (33.3)	PC2	21	.91 (23)	1.39 (33.5)	.2 (.1)
PC2-4205	1.13 (28.7)	1.48 (37.6)	PC2	22	.91 (23)	1.39 (33.5)	.2 (.1)
PC3-4305	1.27 (32.3)	1.70 (43.2)	PC3	31	1.18 (30)	1.57 (40)	.4 (.18)
PC3-4305	1.50 (38.1)	1.95 (49.5)	PC3	32	1.18 (30)	1.57 (40)	.4 (.18)
PC4-4405	1.58 (40)	2.17 (55.1)	PC4	41	1.50 (38)	1.85 (47)	.7 (.32)
PC4-4405	2.09 (53)	2.53 (64.3)	PC4	42	1.50 (38)	1.85 (47)	.7 (.32)
PC5-4505	2.06 (52.4)	2.73 (69.3)	PC5	51	1.93 (49)	2.24 (57)	1.4 (.64)
PC5-4505	2.58 (65.5)	3.30 (83.8)	PC5	52	1.93 (49)	2.24 (57)	1.4 (.64)
PC6-4605	2.61 (66.3)	3.48 (88.4)	PC6	61	2.48 (63)	2.79 (71)	2.8 (1.27)
PC6-4605	3.36 (85.3)	4.20 (106.7)	PC6	62	2.48 (63)	2.79 (71)	2.8 (1.27)
PC6-4605	4.10 (104.1)	4.86 (123.4)	PC6	63	2.48 (63)	2.79 (71)	2.8 (1.27)
PC6-4606	3.92 (99.6)	4.84 (123)	PC6	61	3.54 (90)	2.79 (71)	3.9 (1.78)
PC6-4606	4.68 (119)	5.54 (140.7)	PC6	62	3.54 (90)	2.79 (71)	3.9 (1.78)
PC6-4606	5.44 (138)	6.20 (157.4)	PC6	63	3.54 (90)	2.79 (71)	3.9 (1.78)
PC7-4705	3.92 (99.6)	4.84 (122.9)	PC7	61	3.54 (90)	4.60 (117)	10.6 (4.8)
PC7-4705	4.68 (119)	5.54 (140.7)	PC7	62	3.54 (90)	4.60 (117)	10.6 (4.8)
PC7-4705	5.44 (138)	6.20 (157.4)	PC7	63	3.54 (90)	4.60 (117)	10.6 (4.8)

For use when reduced boring shaft diameter is required for clearance. PC Connection OD should not be larger than the starting diameter of the hole.



4405-41C09 Style 2 shown here. Sold in pairs.

STYLE 1: FOR USE WITH SCMT INSERTS.

Part Number	Insert Holder Size	Insert Type and Size	Insert Screw	Insert Screw Wrench	Weight lbs. (kg)
4305-31S09	31	SCMT 09	028-906	018-008	.1 (.05)
4405-41S09	41	SCMT 09	028-906	018-008	.2 (.1)
4505-51S12	51	SCMT 12	028-907	018-009	.3 (.15)
4605-61S12	61	SCMT 12	028-907	018-009	.6 (.27)
4605-62S12	62	SCMT 12	028-907	018-009	.8 (.36)
4606-63S12	63	SCMT 12	028-907	018-009	1.0 (.45)

- Designed for boring through holes, particularly in castings where core shift is a problem.

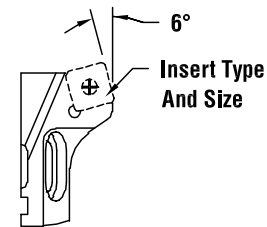

STYLE 2: FOR USE WITH CCMT INSERTS.

Part Number	Insert Holder Size	Insert Type and Size	Insert Screw	Insert Screw Wrench	Weight lbs. (kg)
4205-21C06	21	CCMT 06	028-925	018-007	.1 (.05)
4205-22C06	22	CCMT 06	028-905	018-007	.1 (.05)
4305-31C06	31	CCMT 06	028-905	018-007	.1 (.05)
4305-32C06	32	CCMT 06	028-905	018-007	.1 (.05)
4405-41C09	41	CCMT 09	028-906	018-008	.2 (.1)
4405-42C09	42	CCMT 09	028-906	018-008	.2 (.1)
4505-51C12	51	CCMT 12	028-907	018-009	.3 (.15)
4505-52C12	52	CCMT 12	028-907	018-009	.4 (.18)
4605-61C12	61	CCMT 12	028-907	018-009	.6 (.27)
4605-62C12	62	CCMT 12	028-907	018-009	.8 (.36)
4606-63C12	63	CCMT 12	028-907	018-009	1.0 (.45)

- Designed for boring to square shoulders and deep bores. Also used when step cutting.

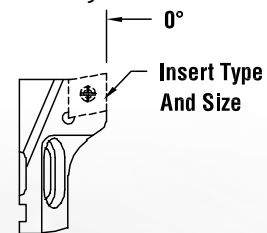

STYLE 3: FOR USE WITH WCMX INSERTS.

Part Number	Insert Holder Size	Insert Type and Size	Insert Screw	Insert Screw Wrench	Weight lbs. (kg)
4205-21W03	21	WCMX 03	028-905	018-007	.1 (.05)
4305-31W03	31	WCMX 03	028-905	018-007	.1 (.05)
4405-41W04	41	WCMX 04	028-905	018-007	.2 (.1)
4505-51W05	51	WCMX 05	028-908	018-003	.3 (.15)
4605-61W08	61	WCMX 08	028-906	018-008	.6 (.27)
4605-62W08	62	WCMX 08	028-906	018-008	.8 (.36)
4606-63W08	63	WCMX 08	028-906	018-008	1.0 (.45)

- Designed for heavy stock removal at moderate horsepower.

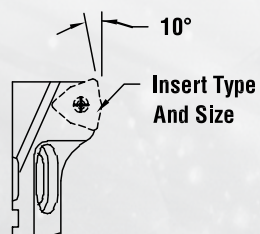

Rough insert holders sold in pairs. Order inserts separately (see pages 42-48).

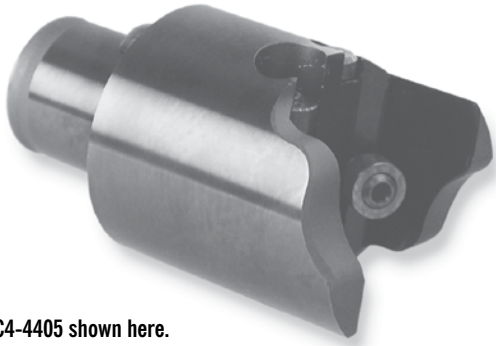

PC4-4405 shown here.

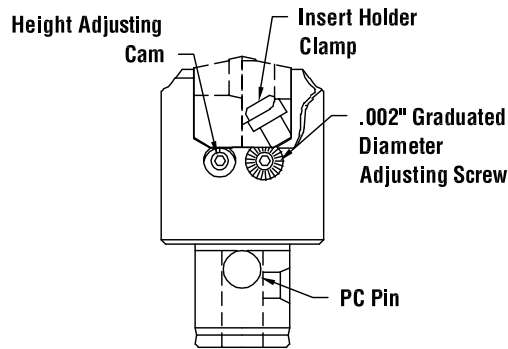

ROUGH BORING COMPONENTS

Part Number	*Diameter Adjust. Screw	*Insert Holder Clamp (Pair)	*Height Adjust. Cam (Pair)	*Wrench Kit	Spare Kit	PC Pin
PC2-4205	4205-11	4205-12	4205-13	4205-14	4205-10	PCP-002
PC3-4305	4305-11	4305-12	4305-13	4305-14	4305-10	PCP-003
PC4-4405	4405-11	4405-12	4405-13	4405-14	4405-10	PCP-004
PC5-4505	4505-11	4505-12	4505-13	4505-14	4505-10	PCP-005
PC6-4605	4605-11	4605-12	4605-13	4605-14	4605-10	PCP-006
PC6-4606	4605-11	4605-12	4605-13	4605-14	4605-10	PCP-006
PC7-4705	4605-11	4605-12	4605-13	4605-14	4605-10	PCP-007
7100-B460	4605-11	4605-12	4605-13	4605-14	4605-10	-

*(Incl.) in spare kit.

INSTALLING INSERT HOLDERS:

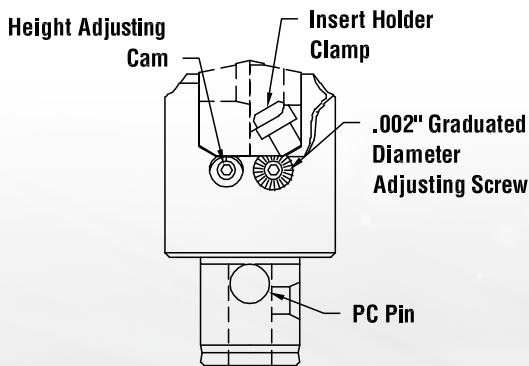

1. Remove the two insert holder clamps and set aside.
2. Place the insert holders in the head, making sure the slot in the bottom of the insert holder engages the head of the diameter adjusting screw.
3. Install the insert holder clamps (cap screw on size two). Make sure that the nut is flush with the end of the screw.
4. Snug up the insert holder clamps.

It is recommended that the Parlec twin boring heads be adjusted on a tool presetter. Refer to Parlec Presetting TMM catalogs for more information.



RECOMMENDED ROUGHING SPEEDS

STEELS

Material	BHN	TT / SN	VN	CT
CARBON STEEL C = 0.15%	125	300-450	600-800	650-1000
CARBON STEEL C = 0.35%	150	300-500	600-800	625-950
CARBON STEEL C = 0.70%	180-250	250-450	550-750	500-750
ALLOY STEEL 4000	125-200	300-500	550-750	500-750
ALLOY STEEL 5000	225	200-400	350-525	300-600
ALLOY STEEL 8000	300	200-400	300-525	350-475
STAINLESS STEEL, ANNEALED 400 SERIES	150-270	250-400	400-600	475-750
STAINLESS STEEL, ANNEALED 300 SERIES	150-220	300-425	350-500	550-650
CAST STEEL, LOW CARBON	150	200-325	450-650	400-550
CAST STEEL, LOW ALLOY	150-250	200-300	250-400	300-425

330BHN = Rc: 35
 250BHN = Rc: 24-25
 220BHN = Rc: 20

All values are in SFM.

OTHER MATERIALS

Material	BHN	TT / SN	AL / VN	AS	C2
MALLEABLE CAST IRON, FERRITIC	110-150	525-700	600-1000	400-900	150-350
MALLEABLE CAST IRON, PEARLITIC	150-270	250-400	400-800	300-800	100-250
GREY CAST IRON, LOW TENSILE	150-220	525-800	400-900	300-1000	200-400
GREY CAST IRON, HIGH TENSILE	200-330	350-600	400-700	300-600	150-300
NODULAR IRON, FERRITIC	125-230	300-500	400-900	450-900	150-375
NODULAR IRON, PEARLITIC	200-300	250-400	400-900	350-650	100-250
ALUMINUM ALLOYS	30-120	-	-	-	600-1200
ALUMINUM ALLOYS, CAST	100-130	-	-	-	600-1200

All values are in SFM.

ALLOWANCE & FEED RATES

Twin Boring Head	Material	Machining Allowance on diameter (Inches) DOC			For Best Finish	Feed Rates (IPR)*	
		Optimum	Min.	Max.		Min.	Max.
PC2-4205 (.94 – 1.34)	Steels	.10	.02	.14	.010	.008	.014
	Cast Iron	.16	.02	.24	.010	.006	.012
	Aluminum	.12	.02	.24	.010	.006	.012
PC3-4305 (1.26 – 1.70)	Steels	.12 - .14	.04	.16 - .18	.014	.012	.018
	Cast Iron	.20	.04	.28	.012	.008	.016
	Aluminum	.20	.04	.28	.014	.012	.018
PC4-4405 (1.58 – 2.17)	Steels	.14 - .16	.04	.18 - .20	.014	.012	.020
	Cast Iron	.24	.04	.31	.012	.012	.016
	Aluminum	.24	.04	.31	.014	.008	.018
PC5-4505 (2.06 – 3.30)	Steels	.24	.06	.35 - .47	.018	.012	.024
	Cast Iron	.39	.04	.55	.016	.012	.018
	Aluminum	.39	.06	.55	.018	.008	.024
PC6-4605 (2.61 – 6.00) PC6-4606 & PC7-4705	Steels	.28 - .39	.06	.35 - .47	.018	.012	.024
	Cast Iron	.47	.04	.55	.016	.008	.018
	Aluminum	.47	.04	.55	.018	.016	.024
ALL BIG BORE ABOVE 6.00	Steels	.28 - .39	.06	.35 - .47	.018	.012	.024
	Cast Iron	.47	.04	.55	.016	.008	.018
	Aluminum	.47	.04	.55	.018	.016	.024

*Feed rate is based on two cutting edges. When step cutting, multiply by .5.

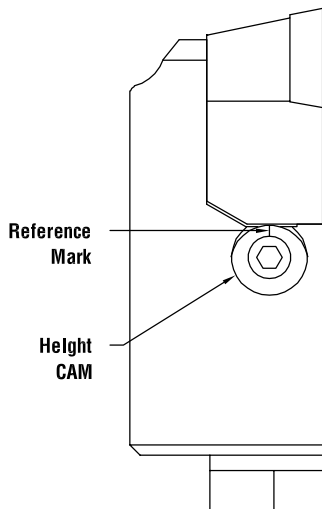

ADJUSTING FOR BALANCED CUTTING:

Balanced cutting allows both cutting edges to work simultaneously. A properly balanced twin cutter may be fed at almost four times the rate of a single cutter. Make sure the height cam is located with the reference mark (lowest point) in the vertical position as shown.

1. Loosen the insert holder clamps. Re-tighten enough to put drag on the insert holder.
2. Adjust the diameter by turning the adjusting screw. Always adjust in the clockwise direction.
3. Tighten the insert holder clamps.
4. Repeat for the second insert holder, adjusting both to $\pm .001"$ (.025) on the diameter.

Balanced cutting occurs when both inserts are set to exactly the same height. This height balancing is much more important than diametric balancing. A slight difference in height, even that caused by the insert tolerance, can have a dramatic effect upon the tool's performance. This is particularly true in the case of long chipping materials.

EXAMPLE OF UNBALANCED CUT:

- Feed rate .016 IPR (.4mm per rev).
- Insert "A" is .003" (.08) higher than insert "B." (The tolerance on an M style insert is .002"-.004") (.05-1)
- The material removed by insert "A" is .008" (.2) + .003" (.08) = .011" (.28)
- The material removed by insert "B" is .008" (.2) + .003" (.08) = .005" (.12)
- The chip taken by insert "A" is over twice as thick as that taken by insert "B".

The difference in cutting forces caused by the differences in insert height illustrated above can have the following effects on the bar's performance:

1. Possible wobble or chatter; extra load on the machine tool;
2. Generally, the bore diameter becomes larger than the set diameter;
3. Uniform chip formation is not possible, making it difficult to break and clear chips.

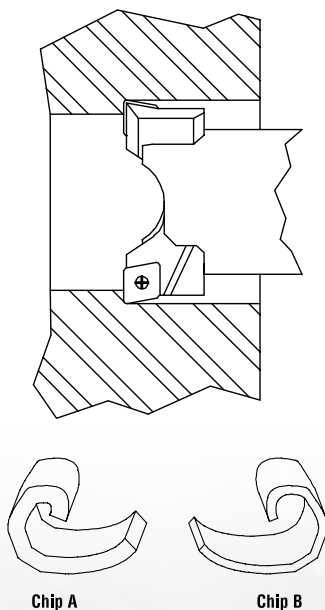

MAXIMUM ALLOWABLE SETTING DIFFERENCE BETWEEN INSERTS FOR BEST PERFORMANCE:

MAXIMUM SETTING DIFFERENCE

Bore Diameter Range" (mm)	Insert Height" (mm)	Cutting Diameter" (mm)
.95 – 1.31" (24.1 - 33.3)	.001 (.025)	.008 (.2)
1.26 – 1.74" (32.3 - 43.2)	.001 (.025)	.012 (.3)
1.58 – 2.17" (40 - 55.1)	.001 (.025)	.012 (.3)
2.06 – 2.83" (52.4 - 69.3)	.002 (.05)	.016 (.4)
2.61 – 6.00" (66.3- 150)	.002 (.05)	.016 (.4)
6.00" + (150 +)	.002 (.05)	.020 (.5)

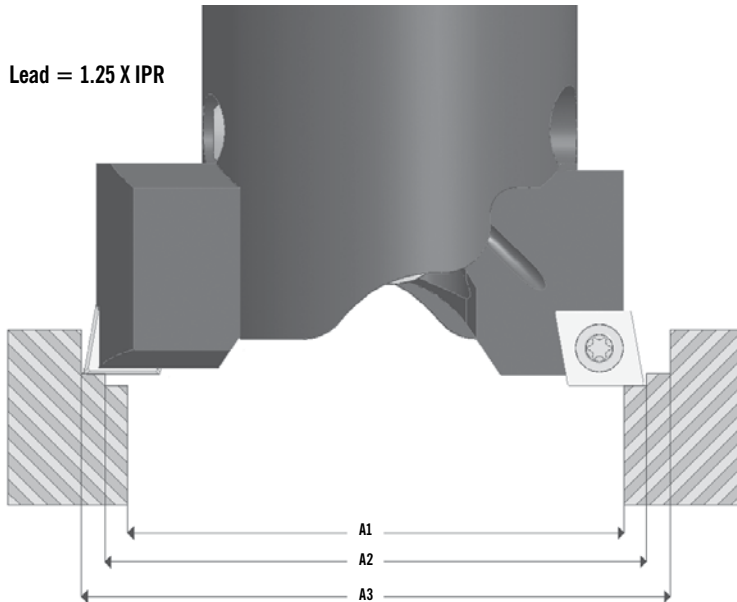

Stepped cutting is utilized when heavy depth of cut is required. The inserts are set at different diameters. The insert cutting the smaller diameter is given axial lead 1.25 times greater than the feed per revolution over the other insert. Use only insert holders with 0° lead. Stepped cutting allows 1.75 x the depth of cut per tables on page 21. Feed rates must be reduced to .5 x appropriate value.

RULES OF STEPPED CUTTING:

1. Use insert holders with 0° lead.
2. Set height in inner cutting edge to provide lead 1.25 times greater than the feed per revolution.
3. Feed rate as roughing with a single cutter.
4. Remove half of the material to be removed with each insert. This should be sufficient for most applications.

TO BALANCE CUTTING FORCES, USE THE FORMULA BELOW:

$$A_2 = .7071 \sqrt{A_3^2 + A_1^2}$$

A₁ – Hole starting diameter

A₂ – Inside cutter set diameter

A₃ – Outside cutter set diameter

ADJUSTING FOR STEPPED CUTTING:

RECOMMENDED TIGHTENING TORQUE IN/ LBS.

Rough Head	Insert Holder	PC Screw
PC2-4205	12 (1.3 Nm)	36 (4.1 Nm)
PC3-4305	36 (4.1 Nm)	48 (5.5 Nm)
PC4-4405	48 (5.5 Nm)	72 (8.3 Nm)
PC5-4505	72 (8.3 Nm)	96 (11.1 Nm)
PC6-4605	72 (8.3 Nm)	120 (13.9 Nm)

Stepped cutting allows removal of more metal since each insert is set at a different diameter.

1. Make sure the height cam is located with the reference mark in the vertical position as shown.
2. Loosen the insert holder clamps. Re-tighten enough to put drag on the insert holder.
3. Adjust the diameter by turning the adjusting screw. Always adjust in the clockwise direction. Set the diameter of each insert to remove approximately one half the material.
4. Using the cam screw, adjust the inner cutting edge so that it has a lead over the outer cutting edge. This lead should be a minimum of 1 1/2 times the feed per revolution.
5. Tighten the insert holder clamps.

NOTE: When using stepped cutting, the feed rate must be that of a single cutter.



*PATENT PENDING

- Wide work range from .078" to 1.89" (2-48 mm) Diameter.
- Precise and repeatable diameter adjustment to .0001" (.002).
- No movement between lock and unlock eliminates setting errors common to other systems.
- High rigidity under all cutting conditions.
- Bored through tool receiver allows the boring tool to be telescoped for optimum rigidity.
- All system components with through hole permits through-spindle coolant.
- Easy to use balancing system permitting vibration free high-speed hole making.
- Available system of completely balanced boring bars and insert holders.
- Tested to over 20,000 RPM.

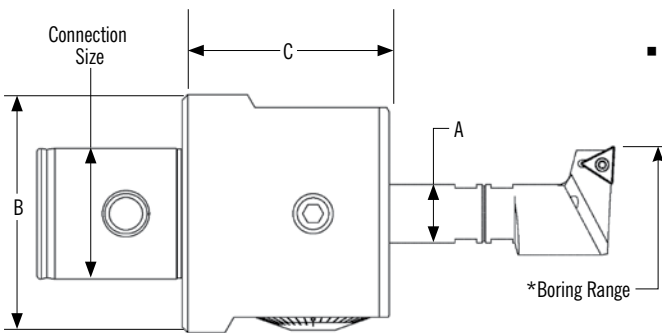

*Calculate maximum boring range by adding adjustment diameter to boring bar minimum diameter.

SMALL DIAMETER BALANCEABLE BORING TOOLS

INCH GRADATION UNITS

Part Number	Bore Range Min	Bore Range Max	Connection Size	Adjustment Diameter	A	B	C	Weight lbs. (kg)
PC6-20SDE62B	0.078" (2 mm)	1.89" (48 mm)	PC6	.315"	5/8"	2.52" (64 mm)	2.24" (57 mm)	3.15 lbs. (1.43 kg)
PC4-2015	0.078" (2 mm)	.790" (20 mm)	PC4	.200"	1/2"	2.00" (50.8 mm)	1.5" (38.1 mm)	1.00 lbs. (0.45 kg)

METRIC GRADATION UNITS

Part Number	Bore Range Min	Bore Range Max	Connection Size	Adjustment Diameter	A	B	C	Weight lbs. (kg)
PC6-20SDM62B	2 mm (.078")	48 (1.89")	PC6	8 mm	5/8"	64 mm (2.52")	57 mm (2.24")	1.43 kg (3.15 lbs.)
PC6-20SDM16B	2 mm (.078")	48 (1.89")	PC6	8mm	16 mm	64 mm (2.52")	57 mm (2.24")	1.43 kg (3.15 lbs.)

REDUCTION BUSHINGS FOR MODULAR BARS

Part Number	Description
62RB-08MM	5/8" to 8 mm
62RB-10MM	5/8" to 10 mm
62RB-12MM	5/8" to 12 mm
62RB-14MM	5/8" to 14 mm
16RB-08MM	16 mm to 8 mm
16RB-10MM	16 mm to 10 mm
16RB-12MM	16 mm to 12 mm
16RB-14MM	16 mm to 14 mm



BORING NOSE WRENCHES

Part Number	Size (mm)
894 14	14
894 12	12
894 10	10
894 8	8
894 6	6

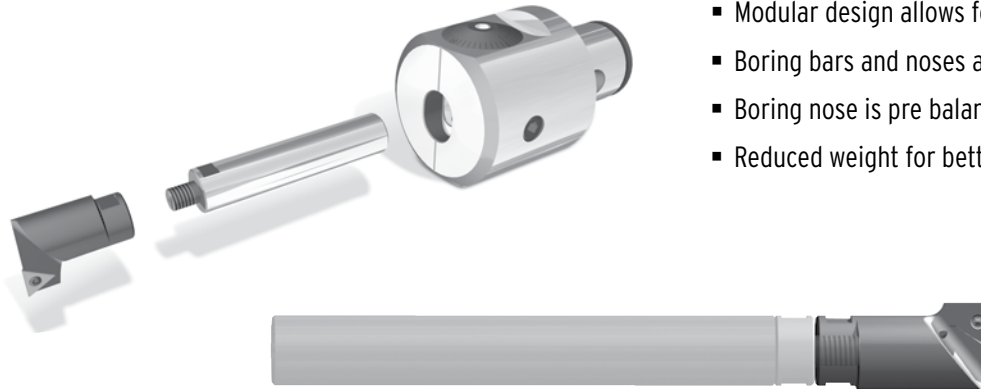

- Modular design allows for reduced inventory.
- Boring bars and noses are coolant-through.
- Boring nose is pre balanced by design to run at high RPM.
- Reduced weight for better performance.

MODULAR BORING NOSES .354" - 1.890" (9 - 48 MM)

Part Number	Min Dia	Recommended Max Dia	Extended Max Dia	Insert Size	Insert Screw	Insert Screw Wrench Sold Separately	Use w/ Bar Size	Wrench Size
BN8X9	.354"(9 mm)	.512"(13 mm)	.669"(17 mm)	TCMT06	028-910	018-002	8 mm	6 mm
BN10X13	.512"(13 mm)	.699"(17 mm)	.827"(21 mm)	TCMT06	028-910	018-002	10 mm	6 mm
BN12X17	.669"(17 mm)	.827"(21 mm)	.984"(25 mm)	TCMT11	812-458	018-007	12 mm	8 mm
BN14X21	.827"(21 mm)	.984"(25 mm)	1.142"(29 mm)	TCMT11	812-458	018-007	14 mm	8 mm
BN16X25	.984"(25 mm)	1.142"(29 mm)	1.299"(33 mm)	TCMT11	028-905	018-007	16 mm or 5/8"	10 mm
BN16X29	1.142"(29 mm)	1.299"(33 mm)	1.457"(37 mm)	TCMT11	028-905	018-007	16 mm or 5/8"	10 mm
BN16X33	1.299"(33 mm)	1.457"(37 mm)	1.614"(41 mm)	TCMT11	028-905	018-007	16 mm or 5/8"	12 mm
BN16X37	1.457"(37 mm)	1.614"(41 mm)	1.772"(45 mm)	TCMT11	028-905	018-007	16 mm or 5/8"	12 mm
BN16X41	1.614"(41 mm)	1.772"(45 mm)	1.890"(48 mm)	TCMT11	028-905	018-007	16 mm or 5/8"	14 mm

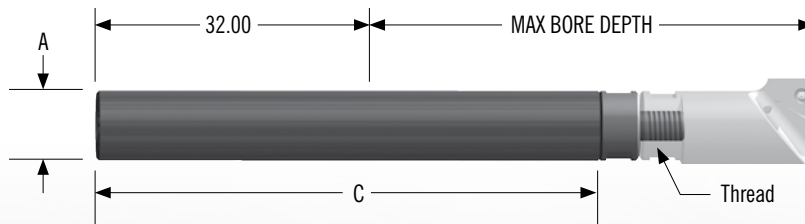

MODULAR BORING BARS BORING RANGE

Part Number	Material	A (Bar Size)	Reduction Bushing Size	C	Min Clamping Length	Max Bore Depth	Thread
BSS8	Steel	8 mm	XXRB-08MM	2.83" (72 mm)	32	1.57" (40 mm)	M5
BSC8	Carbide	8 mm	XXRB-08MM	3.78" (96 mm)	32	2.52" (64 mm)	M5
BSS10	Steel	10 mm	XXRB-10MM	3.78" (96 mm)	32	2.52" (64 mm)	M6
BSC10	Carbide	10 mm	XXRB-10MM	4.41" (112 mm)	32	3.15" (80 mm)	M6
BSS12	Steel	12 mm	XXRB-12MM	3.82" (97 mm)	32	2.56" (65 mm)	M6
BSC12	Carbide	12 mm	XXRB-12MM	5.04" (128 mm)	32	3.78" (96 mm)	M6
BSS14	Steel	14 mm	XXRB-14MM	4.02" (102 mm)	32	2.76" (70 mm)	M6
BSC14	Carbide	14 mm	XXRB-14MM	5.67" (144 mm)	32	4.02" (102 mm)	M6
BSS16	Steel	16 mm	-	4.41" (112 mm)	32	2.78" (70 mm)	M10
BSC16	Carbide	16 mm	-	6.46" (164 mm)	32	4.41" (112 mm)	M10
BSS625	Steel	5/8"	-	4.41" (112 mm)	32	3.15" (80 mm)	M10
BSC625	Carbide	5/8"	-	6.46" (164 mm)	32	5.20" (132 mm)	M10



BORING BARS



Boring Bar SB37-43T105 shown here.

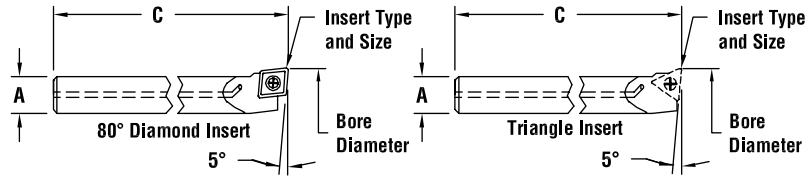

BORING BARS .187" - .433" (4.7 - 11MM) DIAMETER

Part Number	Coolant Part Number	Bore Dia. Min.	Bore Dia. Max. *	Reduction Bushing	Max. Bore Depth	A Dia.	C	Bar Material	Insert Type/Size	Insert Screw	Insert Screw Wrench
CB15-18C056	—	.188"	.218"	XXRB-156	1.50"	.156"	6.00"	Carbide	CDCD 05	028-919	018-002
SB18-23C052	—	.232"	.300"	XXRB-187	1.00"	.187"	2.52"	Steele	CDCD 05	028-919	018-002
CB18-23C054	—	.232"	.300"	XXRB-187	2.00"	.187"	4.00"	Carbide	CDCD 05	028-919	018-002
CB25-30C054	—	.300"	.362"	XXRB-250	2.50"	.250"	4.00"	Carbide	CDCD 05	028-919	018-002
CB25-31T054	—	.310"	.372"	XXRB-250	2.50"	.250"	4.00"	Carbide	TDAB 05	028-920	018-007
SB31-36T054	—	.362"	.430"	XXRB-312	1.75"	.312"	4.00"	Steele	TDAB 05	028-920	018-007
CB31-37T056	—	.372"	.440"	XXRB-312	3.25"	.312"	6.00"	Carbide	TDAB 05	028-920	018-007

*Recommended for Production. For maximum range, see page 20. Minimum bore diameter above is based on a gage insert with .016" nose radius.

REDUCTION BUSHINGS

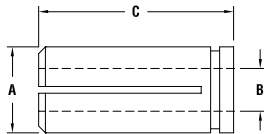

REDUCTION BUSHINGS FOR SOLID INCH SHANKS

Part Number	A	B	C	Weight lbs.
62RB-156	.625	.156	1.42	.1
62RB-187	.625	.187	1.42	.1
62RB-250	.625	.250	1.42	.1
62RB-312	.625	.312	1.42	.1

BORING BARS



Boring Bar CB2-0778-393-KW10 shown here.

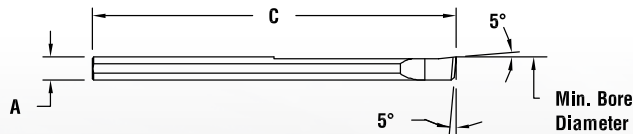

BORING BARS .078" - .197" (2 - 5MM) DIAMETER

Part Number	Bore Dia. Min.	Bore Dia. Max.	Boring Bar Holder	Max. Bore Depth	A Dia.	C Length	Grade
CB2-078-393-KW10	.078 (2)	.118 (3)	12RBX-02MM	.393 (10)	.078 (2)	1.97 (50)	Carbide
CB3-118-590-KW10	.118 (3)	.197 (5)	12RBX-03MM	.590 (15)	.118 (3)	1.97 (50)	Carbide

METRIC BORING BAR HOLDER

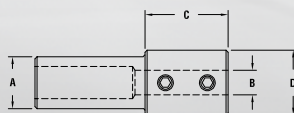

Use with 62RB-12MM or 16RB-12MM

BORING BAR HOLDER

Part Number	A	B	C	D
12RBX-02MM	.472 (12)	2 mm	.62 (15.7)	.62 (15.7)
12RBX-03MM	.472 (12)	3 mm	.62 (15.7)	.62 (15.7)



COMPLETE BORING TOOL KIT

Boring Range .354" – 1,890" (9-48 mm)

PART NUMBER: BTK-PC6S948B

Metric Kits available, please visit www.parlec.com

KIT CONTAINS:

The Balanceable Modular Boring Kit comes equipped with Parlec's small diameter boring head and a wide range of noses, bars, reduction bushings, and wrenches, all of which are packaged in a sleek and durable carrying case. The kit also includes a complete balancing guide to ensure the highest-level of precision possible.

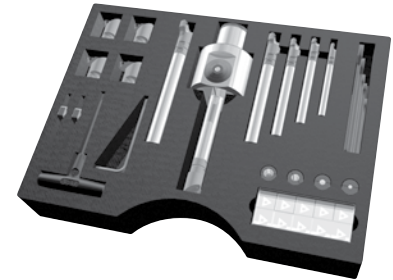

BORING NOSES

Part Number	Qty	Description
BN8X9	1	Boring Nose
BN10X13	1	Boring Nose
BN12X17	1	Boring Nose
BN14X21	1	Boring Nose
BN16X25	1	Boring Nose
BN16X29	1	Boring Nose
BN16X33	1	Boring Nose
BN16X37	1	Boring Nose
BN16X41	1	Boring Nose

BORING BARS

Part Number	Qty	Description
BSS8	1	Steel 8 mm Boring Bar
BSS10	1	Steel 10 mm Boring Bar
BSS12	1	Steel 12 mm Boring Bar
BSS14	1	Steel 14 mm Boring Bar
BSS625	1	Steel 5/8" Boring Bar

INSERTS

Part Number	Qty	Description
T111615TTP	4	TCMT11
T111620C2G	4	TCMT11
T061615TTP	4	TCMT06
T060820C2G	4	TCMT06

BORING HEAD

Part Number	Qty	Description
PC6-20SDE62B	1	Balanceable Boring head

BORING KIT CASE

Part Number	Qty	Description
902.152	1	Boring Tool Kit Case

REDUCTION BUSHINGS

Part Number	Qty	Description
62RB-08MM	1	5/8" to 8 mm Reduction Bushing
62RB-10MM	1	5/8" to 10 mm Reduction Bushing
62RB-12MM	1	5/8" to 12 mm Reduction Bushing
62RB-14MM	1	5/8" to 14 mm Reduction Bushing

WRENCHES

Part Number	Qty	Description
018-105	1	5 mm Hex T-Handle
018-206	1	6 mm Hex Short Arm
018-002	1	T6 Torx
018-007	1	T7 Torx
894 6	1	Wrench 6 mm
894 8	1	Wrench 8 mm
894 10	1	Wrench 10 mm
894 12	1	Wrench 12 mm
894 14	1	Wrench 14 mm

SHANKS

Part Number	Qty	Description
-	-	ORDER SHANKS SEPARATELY See Pages 12-15



USING THE VERNIER SCALE

Find the line in the vernier scale that exactly lines up with a reference line.

Diametral increases in .001" are made by adjusting the dial clockwise one full reference line.

Diametral increases in .0001" are made by adjusting the dial clockwise until the appropriate line on the vernier scale lines up with the next fixed scale reference line.

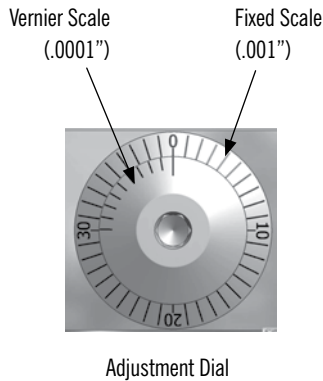

This Example Shows .001" Adjustment

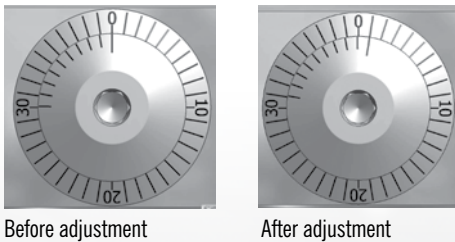

This Example Shows .0005" Adjustment

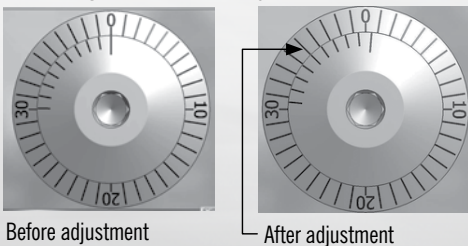

Metric Vernier also available. See page 32.

ASSEMBLY

1. Screw boring nose onto boring bar shank.
2. Loosen the clamp screws.
3. Insert boring bar shank and reduction bushings (if applicable) with the slots 90° to clamp screws. Note: Do not use boring bars with flats.
4. Rotate the boring bar shank to align the insert tip to the alignment mark atop the boring head body. The bar should be slightly above the alignment mark for best timing. Note: Adjusting the position of the insert tip adjusts the "timing" of the bar which optimizes the surface finish and performance.
5. Adjust the boring bar to the minimum desired length.
6. Tighten the clamp screws, Max 20 ft/lbs. (1.13 Nm)

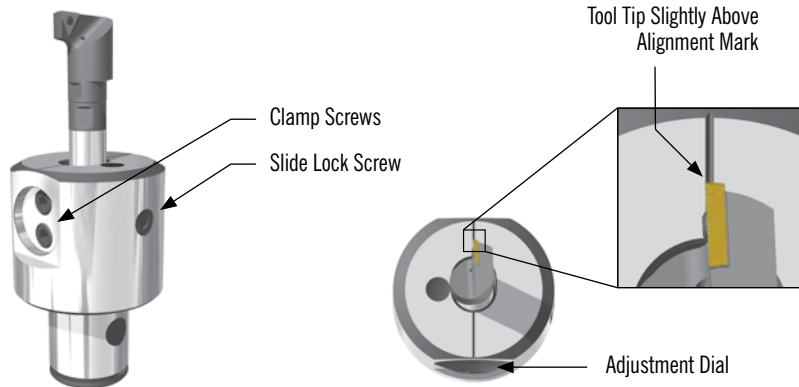

ADJUSTMENT

1. Loosen the slide lock screw.
2. Adjust tool position by turning and reading the dial. The dial is graduated in increments of .001" per graduation on the diameter. Fine adjustments of .0001" can be made utilizing the vernier scale.
3. Tighten the slide lock screw, Max 10 ft/ lbs. (1.13 Nm)

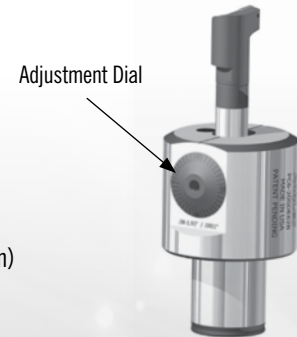

MAINTENANCE

The Parlec precision boring head is constructed of alloy steel, stainless steel and a precision composite material. The internal components are self lubricating. To insure long service life, light spindle or machine oil may be applied to external moving parts. No further maintenance is required.

TORQUE SPECIFICATIONS

SLIDE LOCK SCREW	10 ft/ lbs. (1.13 Nm)
CLAMP SCREW	20 ft/ lbs. (2.23 Nm)



BALANCE CONFIGURATION CHART

Use outlined configurations to achieve a range of boring diameters.
(See balancing chart)

Balance Configuration - 0

Balance Configuration - 1

Balance Configuration - 2

Balance Configuration - 3

Balance Configuration - 4

Balance Configuration - 5

Balance Configuration - 6

Balance Configuration - 7

Balance Configuration - 8

No Weights

Balance Configuration - 9

***Patent Pending**

©2009 Parlec, Inc.

BALANCING CHART

Diameter Range		Preferred Range		Extended Range		Preferred Range		Extended Range			
		Boring Bar Shank / Nose	Balance Configuration	Boring Bar Shank / Nose	Balance Configuration	Boring Bar Shank / Nose	Balance Configuration	Boring Bar Shank / Nose	Balance Configuration		
mm	in	Steel Bars		Steel Bars		Carbide Bars**		Carbide Bars**			
9	0.35	BSS8 / BN8X9	0	BSS8 / BN8X9	4	BSC8 / BN8X9	0	BSC8 / BN8X9	5		
9.5	0.37		0				5			1	5
10	0.39		1				6			2	6
10.5	0.41		1				7			3	7
11	0.43		2				8			4	8
11.5	0.45		2				9			5	9
12	0.47		3				0			6	0
12.5	0.49		3				1			7	1
13	0.51		4				2			8	2
13.5	0.53		4				3			9	3
14	0.55	BSS10 / BN10X13	0	BSS10 / BN10X13	5	BSC10 / BN10X13	0	BSC10 / BN10X13	6		
14.5	0.57		1				6			1	6
15	0.59		2				7			2	7
15.5	0.61		3				8			3	8
16	0.63		3				9			4	9
16.5	0.65		4				0			5	0
17	0.67		4				1			6	1
17.5	0.69		5				2			7	2
18	0.71		5				3			8	3
18.5	0.73		6				4			9	4
19	0.75	BSS12 / BN12X17	0	BSS12 / BN12X17	7	BSC12 / BN12X17	0	BSC12 / BN12X17	8		
19.5	0.77		1				8			1	8
20	0.79		2				9			2	9
20.5	0.81		3				0			3	0
21	0.83		3				1			4	1
21.5	0.85		4				2			5	2
22	0.87		4				3			6	3
22.5	0.89		5				4			7	4
23	0.91		5				5			8	5
23.5	0.93		6				6			9	6
24	0.94	BSS14 / BN14X21	0	BSS14 / BN14X21	8	BSC14 / BN14X21	0	BSC14 / BN14X21	9		
24.5	0.96		1				9			1	9
25	0.98		2				0			2	0
25.5	1.00		2				1			3	1
26	1.02		3				2			4	2
26.5	1.04		3				3			5	3
27	1.06		4				4			6	4
27.5	1.08		4				5			7	5
28	1.10		5				6			8	6
28.5	1.12		5				7			9	7
29	1.14	BSS16 / BN16X25	0	BSS16 / BN16X25	9	BSC16 / BN16X25	0	BSC16 / BN16X25	0		
29.5	1.16		1				0			1	0
30	1.18		2				1			2	1
30.5	1.20		2				2			3	2
31	1.22		3				3			4	3
31.5	1.24		3				4			5	4
32	1.26		4				5			6	5
32.5	1.28		4				6			7	6
33	1.30		5				7			8	7
33.5	1.32		5				8			9	8
34	1.34	BSS16 / BN16X33	0	BSS16 / BN16X33	9	BSC16 / BN16X33	0	BSC16 / BN16X33	9		
34.5	1.36		1				0			1	0
35	1.38		2				1			2	1
35.5	1.40		3				2			3	2
36	1.42		3				3			4	3
36.5	1.44		4				4			5	4
37	1.46		4				5			6	5
37.5	1.48		5				6			7	6
38	1.50		5				7			8	7
38.5	1.52		6				8			9	8
39	1.54	BSS16 / BN16X37	0	BSS16 / BN16X37	9	BSC16 / BN16X37	0	BSC16 / BN16X37	9		
39.5	1.56		1				0			1	0
40	1.57		2				1			2	1
40.5	1.59		3				2			3	2
41	1.61		3				3			4	3
41.5	1.63		4				4			5	4
42	1.65		4				5			6	5
42.5	1.67		5				6			7	6
43	1.69		5				7			8	7
43.5	1.71		6				8			9	8
44	1.73	BSS16 / BN16X41	0	BSS16 / BN16X41	9	BSC16 / BN16X41	0	BSC16 / BN16X41	9		
44.5	1.75		1				0			1	0
45	1.77		2				1			2	1
45.5	1.79		3				2			3	2
46	1.81		3				3			4	3
46.5	1.83		4				4			5	4
47	1.85		4				5			6	5
47.5	1.87		5				6			7	6
48	1.89		5				7			8	7
48.5	1.91		6				8			9	8
49	1.93	6	9	0	9						

****CARBIDE BORING BARS FOR BEST BALANCE RESULTS, SHORTEN BARS OVERALL LENGTH**

Part Number	OAL" (mm)	Part Number	OAL" (mm)
BSC8	2.60 (66)	BSC14	3.94 (100)
BSC10	3.18 (81)	BSC16	4.68 (119)
BSC12	3.50 (89)	BSC62	4.68 (119)

If requested Parlec will shorten OAL at the time of order.

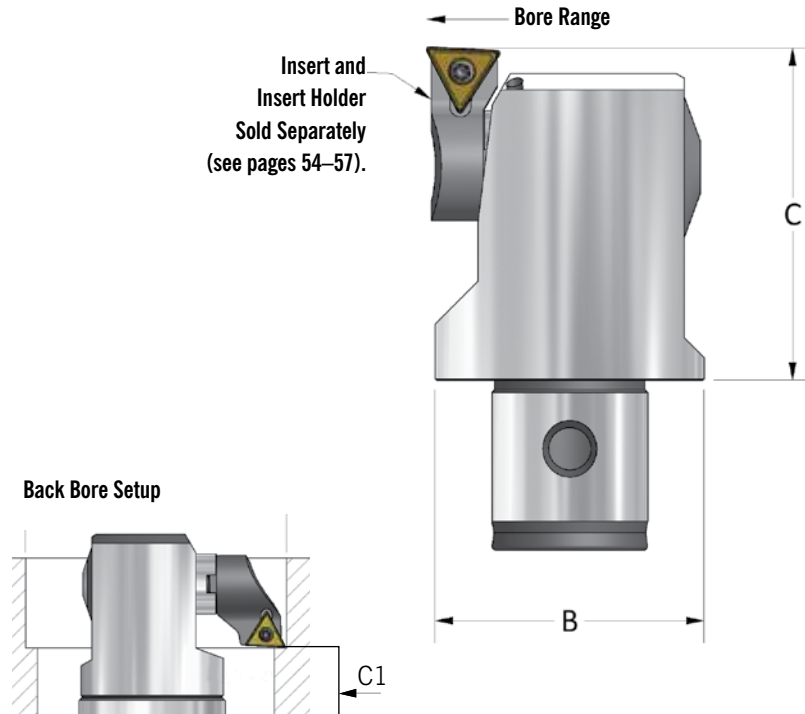

INCH GRADUATION

PART NUMBERS		APPLICATION RANGE			DIMENSION AND INFORMATION					
Boring Head	Insert Holder <i>Sold Separately</i>		Bore Range Min."	Bore Range Max."	B Dia.	C	C1	Insert Holder Clamp	Insert Type and Size	Weight lbs.(kg)
PC2-3215	321-T06-3	*	0.984	1.300	0.925	1.48	0.61	3215-01	TCMT 06**	0.3 (.14)
	322-T06-3		1.254	1.570						
	323-T06-3		1.534	1.850						
PC3-3315	331-T06-3	*	1.240	1.654	1.201	1.61	0.54	3315-01	TCMT 06**	0.5 (.23)
	332-T06-3		1.586	2.000						
	333-T06-3		1.946	2.360						
PC4-3415	341-T11-3	*	1.614	2.126	1.496	1.85	0.51	3415-01	TCMT 11	0.8 (.36)
	342-T11-3		1.968	2.480						
	343-T11-3		2.398	2.910						
PC5-3515	351-T11-3	*	2.087	2.756	1.929	2.24	0.62	3515-01	TCMT 11	1.6 (.73)
	352-T11-3		2.551	3.220						
	353-T11-3		3.071	3.740						
PC6-3615	361-T11-3	*	2.677	4.000	2.48	2.79	0.90	3615-01	TCMT 11	4.1 (1.86)
	362-T11-3		3.637	4.960						
	363-T11-3		4.577	5.900						
PC6-3715	361-T11-3	*	3.937	6.000	3.74	3.35	1.45	3615-01	TCMT 11	7 (3.2)
	362-T11-3		4.970	7.040						
	363-T11-3		6.157	8.220						

* Recommended for dedicated production jobs.

** Note: Additional clearance required for nose radius above .016"



METRIC GRADUATION

PART NUMBERS			APPLICATION RANGE		DIMENSION AND INFORMATION				
Boring Head			Bore Range Min. mm	Bore Range Max. mm	B Dia.	C	Insert Holder Clamp	Insert Type and Size	Weight lbs.(kg)
PC2-3205	321-T06-3	*	25	33	23.5	37.5	3215-01	TCMT 06**	0.3 (.14)
	322-T06-3		32	39.5					
	323-T06-3		39	46.5					
PC3-3305	331-T06-3	*	32	42	30.5	41	3315-01	TCMT 06**	0.5 (.23)
	332-T06-3		41	50.8					
	333-T06-3		50	59.5					
PC4-3405	341-T11-3	*	41	54	38	47	3415-01	TCMT 11	0.8 (.36)
	342-T11-3		50	62.5					
	343-T11-3		61	73.5					
PC5-3505	351-T11-3	*	53	70	49	57	3515-01	TCMT 11	1.6 (.73)
	352-T11-3		65	81.5					
	353-T11-3		78	94.5					
PC6-3605	361-T11-3	*	68	101.5	63	71	3615-01	TCMT 11	4.1 (1.86)
	362-T11-3		93	125.5					
	363-T11-3		117	149.5					
PC6-3705	361-T11-3	*	100	152	95	85	3615-01	TCMT 11	7 (3.2)
	362-T11-3		93	178.5					
	363-T11-3		117	208.5					

Size 1



Size 2



Size 3

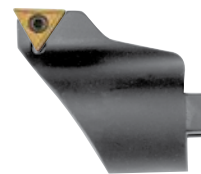

Inserts sold separately. See pages 42-48.

INSERT HOLDER, -3 DEGREE LEAD FOR THROUGH BORE AND BORING TO A SHOULDER. 0 DEGREE ALSO AVAILABLE

3" Part Number	0" Part Number		Insert Holder Size	Extended Size	Insert Type and Size	Insert Screw	Insert Screw Wrench
321-T06-3	321-T06-0	*	2	1	TCMT 06**	028-910	018-002
322-T06-3				2			
323-T06-3				3			
331-T06-3	331-T06-0	*	3	1	TCMT 06**	028-910	018-002
332-T06-3				2			
333-T06-3				3			
341-T11-3	341-T11-0	*	4	1	TCMT 11	028-905	018-007
342-T11-3				2			
343-T11-3				3			
351-T11-3	351-T11-0	*	5	1	TCMT 11	028-905	018-007
352-T11-3				2			
353-T11-3				3			
361-T11-3	361-T11-0	*	6	1	TCMT 11	028-905	018-007
362-T11-3				2			
363-T11-3				3			

* Recommended for dedicated production jobs.

** Note: Additional clearance required for nose radius above .016"



CONFIGURATION

Insert Holder mounted in the standard boring position.



Insert holder mounted in the back boring position.
(See next page for application.)

ASSEMBLY

Install the Insert Holder to the Spindle using the Insert Holder Screw.

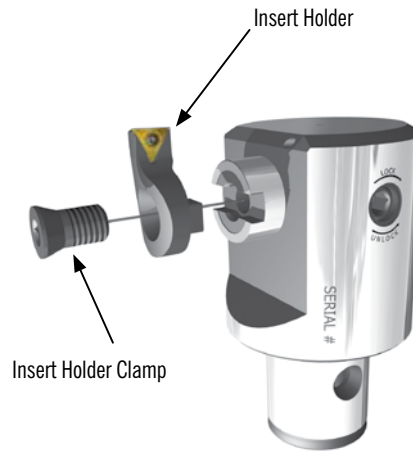

ADJUSTMENT

1. Loosen the Spindle Lock Screw.
2. Adjust tool by turning and reading the dial. The dial is graduated in increments of .001" or .02mm per graduation on the diameter. Fine adjustment of .0001" or .002mm can be made utilizing the vernier scale.
3. Tighten the Spindle Lock Screw.

TIGHTENING TORQUES (MAXIMUM)

Head	Insert Holder Clamp	Slide Lock
2	11 in. lbs. (1 Nm)	5 in. lbs. (0.5 Nm)
3	20 in. lbs. (2.2 Nm)	13 in. lbs. (1.5 Nm)
4	25 in. lbs. (2.8 Nm)	22 in. lbs. (2.5 Nm)
5	50 in. lbs. (5.6 Nm)	50 in. lbs. (5.6 Nm)
6	130 in. lbs. (14.7 Nm)	85 in. lbs. (10 Nm)
7	130 in. lbs. (14.7 Nm)	85 in. lbs. (10 Nm)





USING THE INCH VERNIER SCALE

Find the line in the vernier scale that exactly lines up with a reference line.

Diametral increases in .001" are made by adjusting the Dial clockwise one full line on the fixed scale.

Diametral increases in .0001" are made by adjusting the Dial clockwise until the appropriate line on the vernier scale lines up with the next fixed scale reference line.

This Example Shows .001" Adjustment

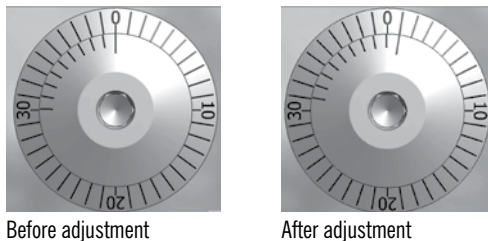

Before adjustment

After adjustment

This Example Shows .0005" Adjustment

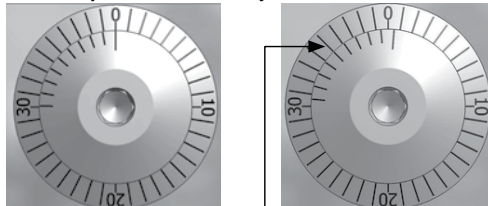

Before adjustment

After adjustment

USING THE METRIC VERNIER SCALE

Find the line in the vernier scale that exactly lines up with a reference line.

Diametral increases in .02mm are made by adjusting the Dial clockwise one full line on the fixed scale.

Diametral increases in .002mm are made by adjusting the Dial clockwise until the appropriate line on the vernier scale lines up with the next fixed scale reference line.

This Example Shows .02mm Adjustment

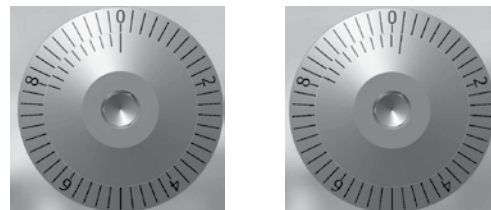

Before adjustment

After adjustment

This Example Shows .01mm Adjustment

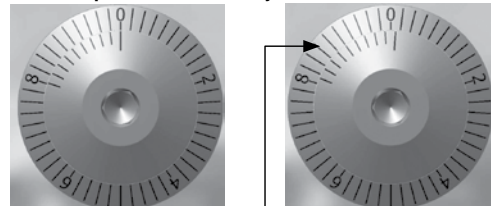

Before adjustment

After adjustment

CALCULATING BACK BORE RANGE

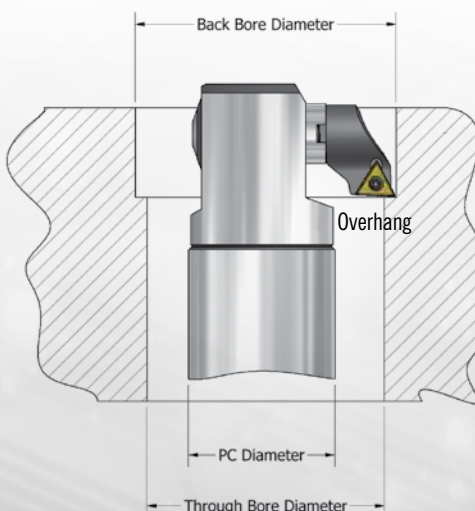

Back Bore Diameter is the same as range in the charts page 30 and 31.

Minimum Through Bore Diameter is calculated:
 $(PC\ Diameter/2) + (Back\ Bore\ Diameter/2) +$
 minimal clearance (.010)

Overhang of insert from boring bar connection should be measured to make sure there is enough clearance.
 Calculate $(Back\ Bore\ Diameter - Through\ Bore\ Diameter)/2$



EFFECTS OF CUTTING SPEED

The effects of cutting speed are illustrated in this chart:

CUTTING SPEED EFFECTS

Variable	Low Speed	High Speed
MACHINING TIME	Longer	Shorter
SURFACE FINISH	Coarser	Finer
PROBABILITY OF VIBRATION	Lower	Higher

RECOMMENDED FINISHING SPEED FOR STEEL

Steels	BHN	TR / TT / SN	C1 / C2	AL	AS	TE
CARBON STEEL C = 0.15%	125	550-750	600-800	150-350	650-1000	950-1300
CARBON STEEL C = 0.35%	150	525-800	600-800	150-350	625-950	850-1200
CARBON STEEL C = 0.70%	180-250	425-625	550-750	150-250	500-750	750-950
ALLOY STEEL 4000	125-200	425-625	550-750	150-250	500-750	750-950
ALLOY STEEL 5000	225	250-500	350-525	150-250	300-600	400-650
ALLOY STEEL 8000	300	200-400	300-525	100-200	350-475	400-500
STAINLESS STEEL, ANNEALED 400 SERIES	150-270	400-625	400-600	150-250	475-750	425-650
STAINLESS STEEL, ANNEALED 300 SERIES	150-220	450-550	350-500	150-300	550-650	425-650
CAST STEEL, LOW CARBON	150	325-450	450-650	100-250	400-550	475-600
CAST STEEL, LOW ALLOY	150-250	250-350	250-400	100-250	300-425	400-575
CAST STEEL, HIGH ALLOY	160-250	—	250-400	75-250	—	400-500

All values are in SFM.

OTHER MATERIALS

Material	BHN	TR / TT / SN	C1 / C2	AL	AS	TE
MALLEABLE CAST IRON, FERRITIC	110-150	525-700	300-450	600-1100	700-1000	—
MALLEABLE CAST IRON, PEARLITIC	150-270	250-400	200-250	600-1000	300-750	—
GREY CAST IRON, LOW TENSILE	150-220	525-800	325-525	400-1200	600-1600	—
GREY CAST IRON, HIGH TENSILE	200-330	350-600	225-400	400-900	350-900	—
NODULAR IRON, FERRITIC	125-230	300-500	300-400	400-950	450-900	—
NODULAR IRON, PEARLITIC	200-300	250-400	200-350	400-700	350-700	—
ALUMINUM ALLOYS	30-120	—	600-3000	—	—	—
ALUMINUM ALLOYS, CAST	100-130	—	600-3000	—	—	—
EXTRA HARD STEEL	50-65RC	—	60-120	—	—	—
WASPALLOY, DISCALLOY, INCOLOY	180-250	—	50-200	—	—	150-350
MONEL, INCONEL	125-250	—	45-90	—	—	90-300
TITANIUM	100-200	—	120-250	—	—	325-500
COPPER, BRASS, ZINC	50-150	—	500-1000	—	—	50-1500

All values are in SFM

Feed rates .002 - .008 IPR. For best finish, feed rate should be approximately 25% of insert nose radius. Refer to next page.

330 BHN = Rc: 35

250 BHN = Rc: 24-25







220 BHN = Rc: 20



EFFECTS OF FINISH FEED RATES

The best surface finish is produced when the tool is fed at approximately 25% of the tool nose radius. The effect on chip formation of the feed rate and depth of cut is illustrated below:

FINISH FEED RATE EFFECTS

Feed Rates/Depth of Cut	Result	Chip Form	Solutions
Low	Chips Bird Nest: Difficult to Remove		1. Increase Depth of Cut 2. Increase Feed Rate
Moderately Low	Long Stringy Chips: Difficult to Remove		1. Increase Depth of Cut 2. Increase Feed Rate
Ideal	Chips Coil Like a Spring: Easy to Remove		Keep Running Make Money!
Slightly Heavy	Slight Deformation of Chip		If Finish is Bad, Decrease Speed
Heavy	Deformation of Chip Increased Cutting Forces		If Finish is Bad, Decrease Speed
Very Heavy	Severe Deformation of Chip Increased Cutting Forces Heat Build Up		If Finish is Bad, Decrease Speed Good Chip for Roughing

DEPTH OF CUT

The depth of cut must be sufficient to allow the tool to cut and not rub. Too small a cut will cause the tool to be pushed away from the work piece by the cutting pressure. The depth of cut must be large enough to let the insert bite as it cuts. Depth of cut is a function of material and insert nose radius. **Generally, the ideal minimum diametral depth of cut is equal to the insert nose radius.**

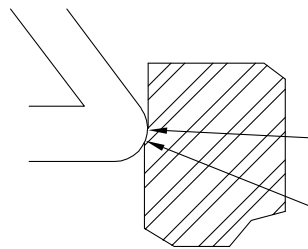

Small Depth of Cut Allows Cutting Forces to Push Insert Out of Cut

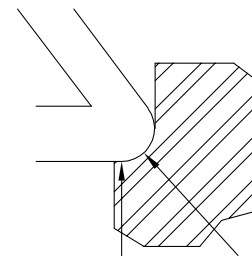

Depth of Cut is Large Enough to Prevent Cutting Forces From Pushing Insert Out of Cut

EFFECT OF NOSE RADIUS ON SURFACE FINISH

A larger nose radius produces a better surface finish. Care must be taken not to over feed the nose radius.

▪ A .016 nose radius insert fed at .004 IPR produces a finish as shown at the right:

▪ A .016 nose radius insert fed at .008 IPR produces a finish as shown at the right:

▪ A .016 nose radius insert fed at .016 IPR produces a finish as shown at the right:

*For best finish, generally feed at 25% of nose radius.

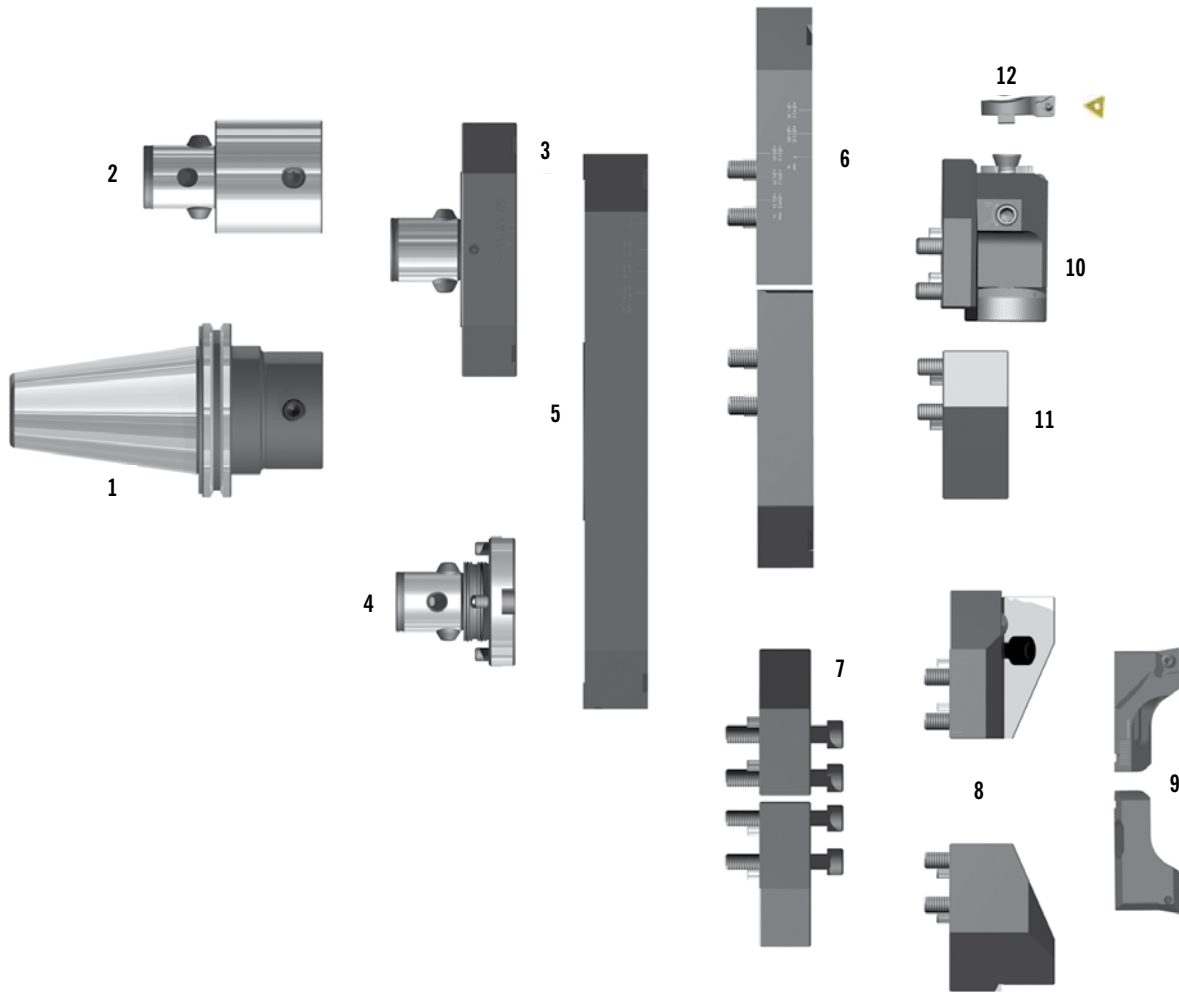

5.95" - 23.8" (152-605MM) LARGE DIAMETER TREE

Component	Selection Criteria	Catalog page	
1	Modular Shank	Machine tool taper and projection requirement	Page 12-15
2	PC Extensions	Extended reach requirements	Page 26
3	PC6 Extension Base	One piece design for 5.95"-8.50" (151.2 - 216mm)	Page 38
4	Extension Base Coupler	Modular connection between shank and ext. base	Page 37
5	Extension Base	Bore range 8.50" (216mm) and up	Page 37
6	Extension Slide	Extends range of base to eliminate next size	Page 39
7	Riser	Extends reach when used for OD boss	Page 39
8	Insert Holder Base	Mounts rough insert holders to base	Page 40
9	Twin Bore Insert Holders	Mounts and adjusts insert to diameter	Page 37
10	Finish Boring Unit	For precision adjustment of finish bore diameter	Page 41
11	Counter Weight	Offset the mass of Finish Boring Unit for high rpm	Page 41
12	Finish Insert Holder	Mounts finish Insert to Finish Boring Unit	Page 41



EXTENSION BASE COUPLER

- Available in PC6 and PC7 connections.
- Modular Extension Base Couplers connects the Extension Slide directly to the face of the PC connection eliminating an additional connection and loss of rigidity.
- Coolant through for direct supply of coolant to cutting edge.
- 0, 45 or 90 Degree orientation setting allows for tool extension timing for carousel clearance without the need for special shanks.

EXTENSION BASE COUPLER

Connection Size	Part Number	Mass lbs. (kg)
PC6	PC6-EBC	2.3 (1.1)
PC7	PC7-EBC	2.75 (1.3)

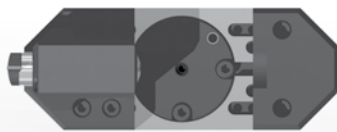

0 Degree orientation

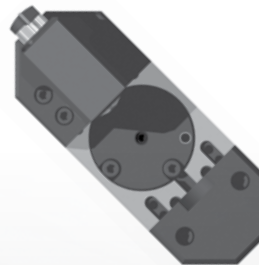

45 Degree orientation



90 Degree orientation

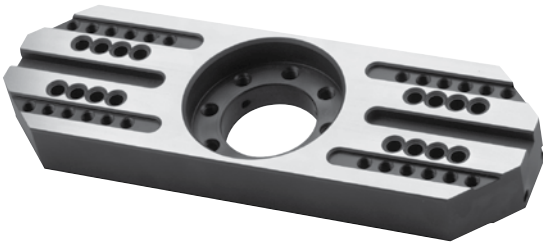

EXTENSION BASES

- Extension bases have 3 or 4 positions to maximize bore range.
- Coolant supply to Insert Holder pair or Finish Boring Unit to supply coolant directly to the cutting edge.
- Used with Extension Base Couplers allows timing of cutting tip eliminating tool interference in carousel.

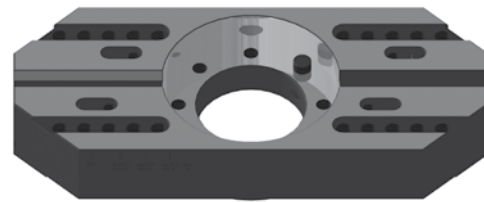
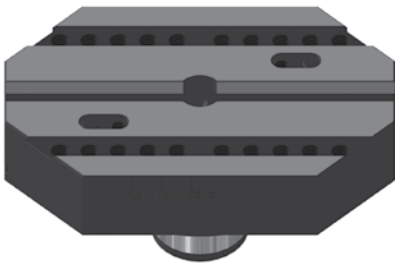

INTEGRAL PC CONNECTION BORING RANGE

	Min.	Max.	Extension Base	Mass lbs.	kg
Inch	5.95	8.50	PC6-910-850	6	2.72
Metric	151.2	216			

BORING RANGE

	Min.	Max.	Extension Base	Mass lbs.	kg
Inch	8.50	11.05	910-1150	6.6	3
Metric	216	281			
Inch	11.05	13.60	910-1360	9.4	4.3
Metric	280	346			
Inch	13.60	16.15	910-1615	12.4	5.6
Metric	346	410			
Inch	16.15	18.70	910-1870	15.4	7
Metric	410	475			
Inch	18.70	21.25	910-2125	18.4	8.4
Metric	475	540			
Inch	21.25	23.80	910-2380	21.3	9.7
Metric	539	605			
Inch	23.80	26.35	910-2635	24.2	11
Metric	605	672			

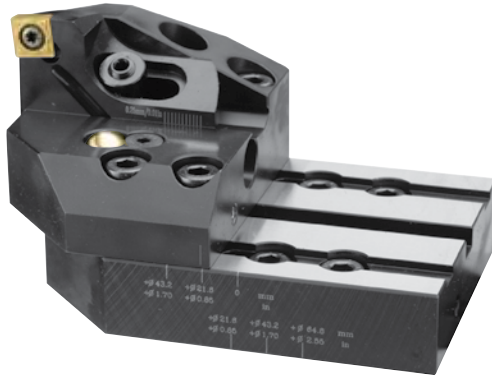

EXTENSION SLIDE

- Extends the range of extension base 2.55" or 65 mm.
- Eliminates the requirement of next slide diameter for low volume or non-production applications.

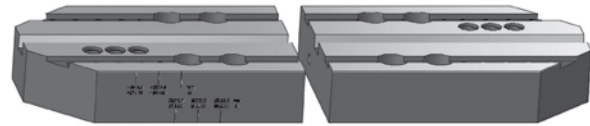

BORING RANGE

	Bore Range	Range Extension Slide (pair)	Mass lbs.	kg
Inch	+2.55	910-RES	7.9	3.6
Metric	+65			

Adds 1" (25.4) to projection length.

MOUNTING CAP SCREWS (8 INCL.)

SHCSM8X30 (each)

RISER

- Extends the reach of insert for OD boring

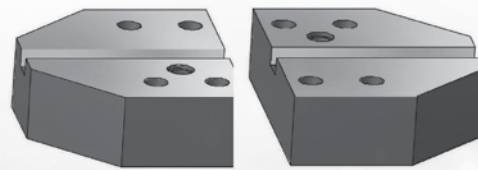

	Bore Reach	Z Length Riser (pair)	Mass lbs.	kg
Inch	+1.00	910-ZRIS	4.4	2
Metric	+25.4			

MOUNTING CAP SCREWS (8 INCL.)

SHCSM8X50 (each)

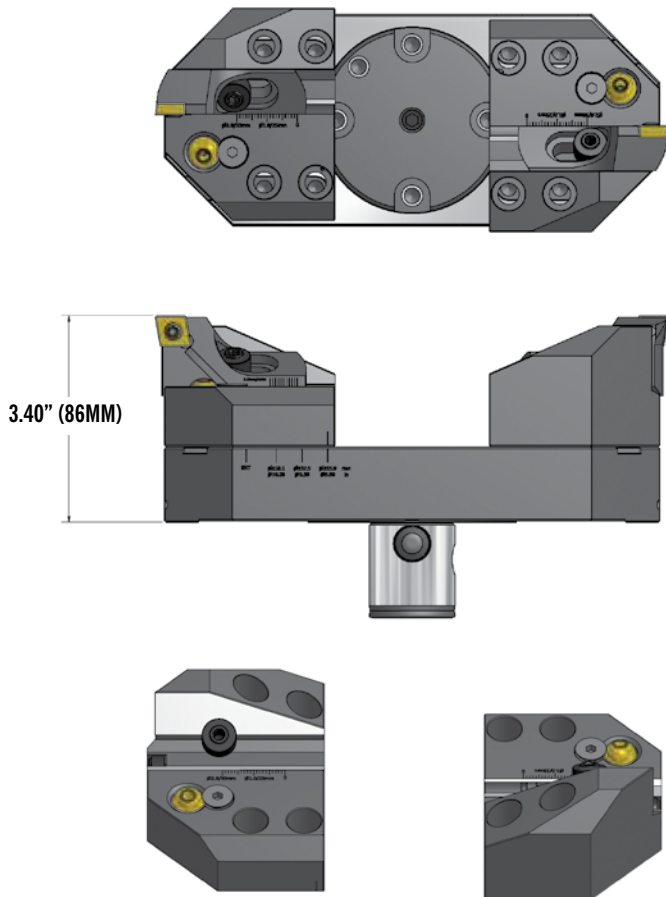

ROUGH BORING HOLDER BASE

- 3 positions allows a single insert holder to bore the complete range.
- Coolant directed onto the cutting edge for maximum cooling, chip forming and tool life.
- Independent height and diameter setting permits balanced cutting with production of almost perfectly round holes from the beginning, irrespective of core shifts.
- Two height balanceable cutting edges results in metal removal at rates almost 4 times that of a single cutter.
- Height adjustments are made with a cam that supports the insert holder where needed, at the furthest radial point.
- Each insert holder can be adjusted individually in diameter with a dial screw for fast, easy set-up operations.
- Balanced or stepped cutting can be done with the same set of insert holders permitting heavy stock removal and eliminating the need to purchase two sets of insert holders.
- Standard through-spindle coolant capability cools the insert and flushes chips.
- ISO standard inserts - requires no special expensive inserts.
- Square SCMT insert holders with 6° lead for through hole boring or extreme core shifts.
- Diamond CCMT insert holders for boring to a square holder, or deep bore lengths.
- Trigon WCMT insert holders for applications requiring heavy stock removal.

HOLDER BASE

	Bore Range	Holder Base (pair)	Mass lbs.	kg
Inch	2.55	910-HBP	4.7	2.1
Metric	65			

SPARE COMPONENTS

Mounting Cap Screw *	Insert Holder Clamps	Diameter Adjust Screw	Height Adjusting Cam
SHCSM8X20 (each)	4605-12 (pair)	4605-11 (pair)	4605-13 (pair)

* 8 (Incl.)

INSERT HOLDERS

Part Number	Size	Insert Type and Size	Lead angle	Insert screw	Insert Screw Wrench	Mass lbs.	kg
4605-61S12	61	SCMT 12	6 degrees	028-907	018-009	0.6	.3
4605-61C12	61	CCMT12	0 degrees	028-907	018-009	0.6	.3
4605-61W08	61	WCMX08	10 degrees	028-906	018-008	0.6	.3



Other styles and a complete listing of Twin Bore Insert Holders on page 19.

For speeds, feeds and material removal recommendations and Boring Bar set up see pages 20–23.

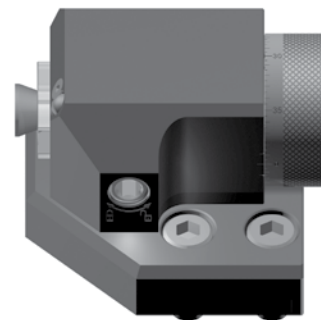
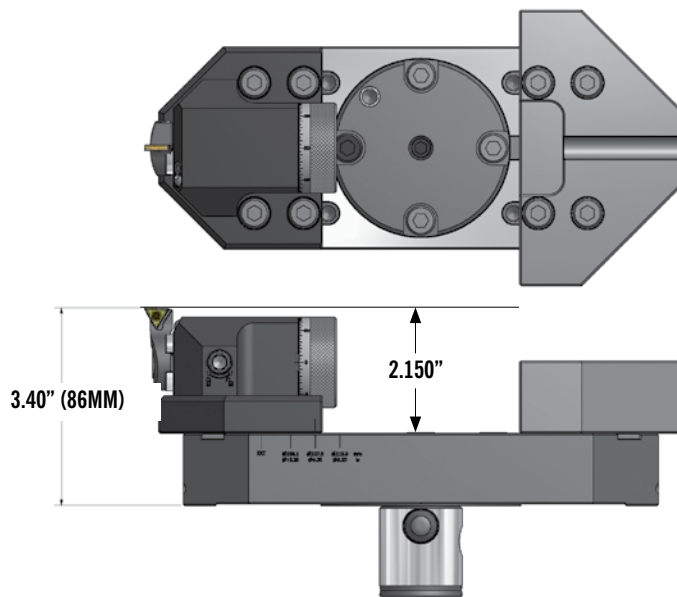

BORING RANGE

	Bore Range	Finish Boring Unit	Mass lbs.	kg
Inch	2.55	910-FBU	3.2	1.44
Metric	65	910-FBUM		



Insert holder

INSERT HOLDERS

Part Number	Size	Insert Type and Size	Lead angle	Insert screw	Insert Screw Wrench
361-T11-3	6	TCMT 11	-3 degrees	028-905	018-007

Complete listing of Finish Insert Holders on page 31.

COUNTER WEIGHT

Part Number	Mass lbs.	kg
910-FCW	3.2	1.44

SPARE PARTS

Insert Holder Clamp Screw	Mounting Screws (4 Incl.)
3615-01	SHCSM8X20 (each)

For speeds, feeds and material recommendations, refer to pages 34–35.

FINISH BORING UNIT

- .0005" (.02) adjustment graduation
- Coolant directed onto the cutting edge for maximum cooling, chip forming and tool life.
- No movement between lock and unlock eliminates setting errors common to other systems.
- Large easy to adjust dial.

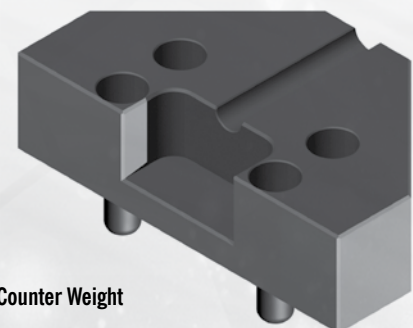

Counter Weight



SHAPE:

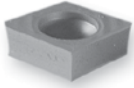

SQUARE

- For rough boring through holes and castings to avoid exit hole breakout.
- Four usable edges for maximum insert life.



80° DIAMOND

- For rough boring to a shoulder or deep bore depths where maximum rigidity of the bar is required.
- For finishing small diameters where maximum edge strength is required.

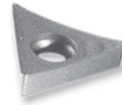

TRIANGLE

- For finishing with three corners for maximum insert life.



TRIGON

- For rough boring when large depth of cut is required or when extreme core shift is experienced.

CARBIDE GRADE:

Select the proper insert grade from pages 40-41. Material type, machine capabilities and type of hole, i.e., Interrupted Cut, can affect the grade of carbide used.

Coated

- Longer service life at higher speeds.

Uncoated

- Less expensive and effective in materials for which coatings do not add any benefit.

Cermet

- Yields the highest speed and durability for selected materials.

RADIUS:

Finish, bar rigidity, insert life, and engineering features of the workpiece all contribute to choosing the proper insert radius.

Larger

- Better surface finish and longer insert life.

Smaller

- Less cutting pressures, in extreme conditions, reduced bar flex and chatter.

PERIPHERY:

Pressed

- Utility grade for general purpose. Longer tool life.

Ground

- Better for finishing where tight bore tolerances are required.



WARNING

The use of carbide in cutting is generally a safe and reasonable practice. When used properly, these products are designed to be safe and without risk to health and property. Please review the recommended use and pay particular attention to insure the tooling is used within its designed speed ranged and operating forces. Misuse may represent a hazard to people and property.

These products use materials which are classified as hazardous by OSHA. This may include one or more of the following carbide, titanium carbide, chromium carbide, chromium cadmium, cobalt, and nickel.

Carbide is a material which is brittle in nature. It will fracture from shock or impact which may cause pieces to detach at high velocities. Carbides should not be hammered or fitted with undo force. Suitable eye protection should be worn during all processes.

Carbide grinding may release dangerous levels of cobalt. Conventional precautions related to the operations of safe grinding should always be observed.

Additional information and material safety data sheets are available on request.

DIAGRAM DESCRIPTION

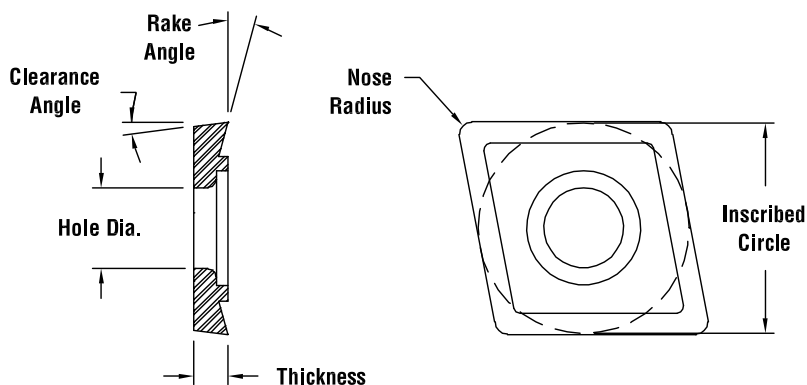

PART NUMBER EXPLANATION

EXAMPLE: T111615TTP

(T)	Size (11)	Radius (16)	Rake Angle (15)	Grade (TT)	Periphery (P)
T=TRIANGULAR	05,06,09,11	08=.008	00=0°	See Carbide	-
S=SQUARE	09,12	12=.016	06=6°	Grade	P=Pressed
C=80° DIAMOND	05,06,09,12	16=.016	15=15°	Section	G=Ground
W=TRIGON	03,04,05,08	31=.031	20=20°	Pages	-
-	-	47=.047	23=23°	114-115	-



		ISO	ANSI		
P STEELS, CAST STEELS, STAINLESS STEELS, AND LONG CHIPPING CAST IRON.	01	C8		CT	
	10				AL
	20	C7		CR	C7
	30	C6	SN		CM
	40			TT	
	50	C5			
M STEEL, CAST STEEL, MANGANESE STEELS AND HEAT RESISTANT ALLOYS.	10			C2	TE CT C7
	20		TT		
	30		VN		
	40				
K CAST IRON, ALUMINUM, NON-FERROUS METALS.	01	C4		TE	AL CT
	10	C3	AS		
	20	C2		C2	
	30	C1		C1	



UNCOATED GRADES

- C1**
 - Is a strong micro grain carbide which resists chipping, breaking, and edge build-up. Great for roughing at high feed rates on interrupted cuts. Use for titanium, high temperature alloys, inconel, and hastalloy.
- C2**
 - Is a relatively fine grain grade on a WC-CO base. It has very good toughness and good rake angle resistance to abrasive wear. Applications include stainless steels, cast irons, non-ferrous metals, and most high temperature alloys.
- C7**
 - Finish and light roughing non-coated grade for steel and steel castings. Performs best in favorable conditions. High speeds and moderate feeds.

TITANIUM COATED GRADES

- TT**
 - Is a very tough grade with a triple coating of Tin, TiC, and TiN. It is a good grade for roughing and finishing in less than ideal conditions. Used in machining steels and stainless steels at low speeds.
- TE**
 - Is a carbide grade with a PVD coating. It is used for machining aerospace materials, high temperature alloys, and stainless steels.
- TR**
 - Is a PVD coated micro grain carbide. Performs well in alloy steels, nickel-based materials, and heat-treated materials up to Rc: 40.
- SN**
 - Delivers outstanding performance in moderate-roughing to semi-finishing operations, especially in interrupted cuts. An advanced multi-layer coating (TiCN/Al₂O₃/TiN), applied over a cobalt enriched substrate, gives SN a near optimum balance of toughness, surface lubricity, and resistance to metal build-up to yield excellent wear resistance throughout its application range.
- VN**
 - Is a micro-grained grade with an excellent balance of toughness and wear resistance. Coated with PVD TiN for improved lubricity and wear resistance with up-sharp cutting edges, VN excels in light roughing to high-speed finishing of high-temperature alloys, stainless steels, cast iron, aluminum, and non-ferrous materials.

CERMET GRADES

- CT**
 - Is a cermet grade of TiC and TiN particles in a nickel cobalt binder. It is used in finishing steels at high cutting speeds.
- CM**
 - Is a cermet grade. It is slightly less hard than CT and can be used in less favorable conditions.
- CR**
 - Is a titanium nitride cermet which combines toughness and edge wear. Use on steels up to Rc: 35.
- CC**
 - A titanium coated cermet for better wear resistance.

ALUMINUM OXIDE COATED GRADES

- AL**
 - Is an AL₂O₃ coated insert. Its application is machining cast iron and steels at moderately high speeds.

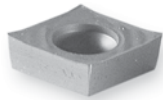

80° Diamond Insert shown here.

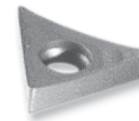
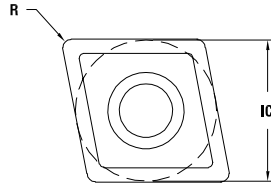
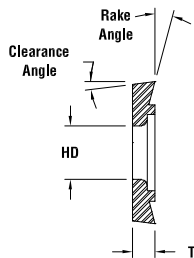

Triangle Insert T061206C7G shown here.

SIZE CDCD 05

Part Number	IC	Clearance Angle	R	T	Rake Angle	HD	Grade	Type	Periphery
C050700C2G	.156	15°	.007	.040	0°	.084	C2	Uncoated	Ground
C051600C2G	.156	15°	.016	.040	0°	.084	C2	Uncoated	Ground
C050700TRG	.156	15°	.007	.040	0°	.084	TR	Coated	Ground
C051600TRG	.156	15°	.016	.040	0°	.084	TR	Coated	Ground
C050700PCD	.156	15°	.007	.040	0°	.084	PCD	Diamond	Ground
C051600PCD	.156	15°	.016	.040	0°	.084	PCD	Diamond	Ground

SIZE CCMT 06

Part Number	IC	Clearance Angle	R	T	Rake Angle	HD	Grade	Type	Periphery
C061615C2P	.250	7°	.016	.094	15°	.110	C2	Uncoated	Pressed
C063115C2P	.250	7°	.031	.094	15°	.110	C2	Uncoated	Pressed
C061620C2G	.250	7°	.016	.094	20°	.110	C2	Uncoated	Ground
C061615TTP	.250	7°	.016	.094	15°	.110	TT	Coated	Pressed
C063115TTP	.250	7°	.031	.094	15°	.110	TT	Coated	Pressed

SIZE CCMT 09

Part Number	IC	Clearance Angle	R	T	Rake Angle	HD	Grade	Type	Periphery
C091615C2P	.375	7°	.016	.156	15°	.173	C2	Uncoated	Pressed
C093115C2P	.375	7°	.031	.156	15°	.173	C2	Uncoated	Pressed
C091620C2G	.375	7°	.016	.156	20°	.173	C2	Uncoated	Ground
C091615TTP	.375	7°	.016	.156	15°	.173	TT	Coated	Pressed
C093115TTP	.375	7°	.031	.156	15°	.173	TT	Coated	Pressed

SIZE CCMT 12

Part Number	IC	Clearance Angle	R	T	Rake Angle	HD	Grade	Type	Periphery
C121615C2P	.500	7°	.016	.188	15°	.216	C2	Uncoated	Pressed
C123115C2P	.500	7°	.031	.188	15°	.216	C2	Uncoated	Pressed
C124715C2P	.500	7°	.047	.188	15°	.216	C2	Uncoated	Pressed
C121620C2G	.500	7°	.016	.188	20°	.216	C2	Uncoated	Ground
C123120C2G	.500	7°	.031	.188	20°	.216	C2	Uncoated	Ground
C121615TTP	.500	7°	.016	.188	15°	.216	TT	Coated	Pressed
C123115TTP	.500	7°	.031	.188	15°	.216	TT	Coated	Pressed
C124715TTP	.500	7°	.047	.188	15°	.216	TT	Coated	Pressed



SIZE TDAB 05

Part Number	IC	Clearance Angle	R	T	Rake Angle	HD	Grade	Type	Periphery
T050700C2G	.160	15°	.007	.047	0°	.094	C2	Uncoated	Ground
T051600C2G	.160	15°	.016	.047	0°	.094	C2	Uncoated	Ground
T050700TRG	.160	15°	.007	.047	0°	.094	TR	Coated	Ground
T051600TRG	.160	15°	.016	.047	0°	.094	TR	Coated	Ground
T050700PCD	.160	15°	.007	.047	0°	.094	PCD	Diamond	Ground

SIZE TCMT 06

Part Number	IC	Clearance Angle	R	T	Rake Angle	HD	Grade	Type	Periphery
T061206C7G	.156	7°	.008	.078	6°	.087	C7	Uncoated	Ground
T061220C2G	.156	7°	.008	.078	20°	.087	C2	Uncoated	Ground
T060815C2P	.156	7°	.008	.078	15°	.087	C2	Uncoated	Pressed
T061615C2P	.156	7°	.016	.078	15°	.087	C2	Uncoated	Pressed
T060815TTP	.156	7°	.008	.078	15°	.087	TT	Coated	Pressed
T061615TTP	.156	7°	.016	.078	15°	.087	TT	Coated	Pressed
T060820CTG	.156	7°	.008	.078	20°	.087	CT	Cermet	Ground
T061620CTG	.156	7°	.016	.078	20°	.087	CT	Cermet	Ground
T060815CTP	.156	7°	.008	.078	15°	.087	CT	Cermet	Pressed
T061615CTP	.156	7°	.016	.078	15°	.087	CT	Cermet	Pressed
T061600PCD	.156	7°	.016	.078	0°	.087	PCD	Diamond	Ground

SIZE TCMT 11

Part Number	IC	Clearance Angle	R	T	Rake Angle	HD	Grade	Type	Periphery
T111615C7P	.250	7°	.016	.094	15°	.108	C7	Uncoated	Pressed
T111600C2P	.250	7°	.016	.094	0°	.108	C2	Uncoated	Pressed
T111615C2P	.250	7°	.016	.094	15°	.108	C2	Uncoated	Pressed
T113115C2P	.250	7°	.031	.094	15°	.108	C2	Uncoated	Pressed
T111620C2G	.250	7°	.016	.094	20°	.108	C2	Uncoated	Ground
T111600C2G	.250	7°	.016	.094	0°	.108	C2	Uncoated	Ground
T113120C2G	.250	7°	.031	.094	20°	.108	C2	Uncoated	Ground
T110815TTP	.250	7°	.008	.094	15°	.108	TT	Coated	Pressed
T111615TTP	.250	7°	.016	.094	15°	.108	TT	Coated	Pressed
T113115TTP	.250	7°	.031	.094	15°	.108	TT	Coated	Pressed
T110823TEG	.250	7°	.008	.094	15°	.108	TE	Coated	Ground
T111623TEG	.250	7°	.016	.094	23°	.108	TE	Coated	Ground
T111615CTP	.250	7°	.016	.094	15°	.108	CT	Cermet	Pressed
T111615CMP	.250	7°	.016	.094	15°	.108	CM	Cermet	Pressed
T111600ASP	.250	7°	.016	.094	0°	.108	AS	Coated	Pressed
T111600PCD	.250	7°	.016	.094	0°	.108	PCD	Diamond	Ground
T111615SNG	.250	7°	.016	.094	15°	.108	SN	Coated	Ground
T113115SNG	.250	7°	.031	.094	15°	.108	SN	Coated	Ground
T111615VNG	.250	7°	.016	.094	15°	.108	VN	Coated	Ground

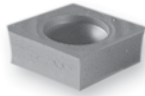

Square Insert S091615C2P shown here.

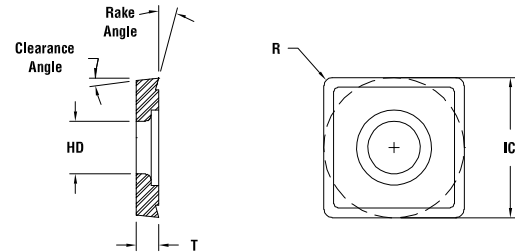

SIZE SCMT 09

Part Number	IC	Clearance Angle	R	T	Rake Angle	HD	Grade	Type	Periphery
S091615C2P	.375	7°	.016	.156	15°	.173	C2	Uncoated	Pressed
S093115C2P	.375	7°	.031	.156	15°	.173	C2	Uncoated	Pressed
S091615TTP	.375	7°	.016	.156	15°	.173	TT	Coated	Pressed
S093115TTP	.375	7°	.031	.156	15°	.173	TT	Coated	Pressed

SIZE SCMT 12

Part Number	IC	Clearance Angle	R	T	Rake Angle	HD	Grade	Type	Periphery
S123115C2P	.500	7°	.031	.188	15°	.216	C2	Uncoated	Pressed
S121615TTP	.500	7°	.016	.188	15°	.216	TT	Coated	Pressed
S123115TTP	.500	7°	.031	.188	15°	.216	TT	Coated	Pressed
S124715TTP	.500	7°	.047	.188	15°	.216	TT	Coated	Pressed



Trigon Insert W033115STTP shown here.

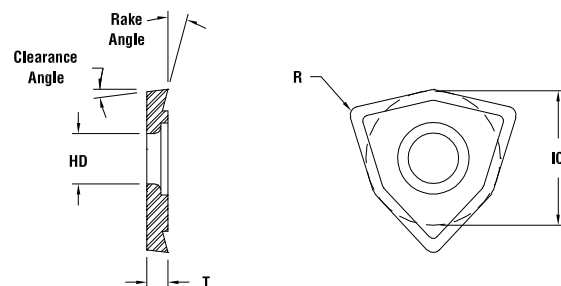

SIZE WCMX 03

Part Number	IC	Clearance Angle	R	T	Rake Angle	HD	Grade	Type	Periphery
W033115TTP	.218	7°	.031	.093	15°	.110	TT	Coated	Pressed

SIZE WCMX 04

Part Number	IC	Clearance Angle	R	T	Rake Angle	HD	Grade	Type	Periphery
W043115TTP	.250	7°	.031	.093	15°	.122	TT	Coated	Pressed

SIZE WCMX 05

Part Number	IC	Clearance Angle	R	T	Rake Angle	HD	Grade	Type	Periphery
W053115TTP	.312	7°	.031	.125	15°	.126	TT	Cermet	Pressed

SIZE WCMX 08

Part Number	IC	Clearance Angle	R	T	Rake Angle	HD	Grade	Type	Periphery
W084715TTP	.500	7°	.047	.187	15°	.169	TT	Coated	Pressed



- Used for all boring heads with 2 designation ie. PC4 - 2415, or PC2 - 2205.

STYLE 1

Part Number	Insert Holder Size	Insert Type and Size	Insert Screw	Insert Screw Wrench
2215-T06	2	TCMT 06	028-910	018-002
2315-T06	3	TCMT 06	028-910	018-002
2315-T11	3	TCMT 11	812-458	018-007
2415-T11	4	TCMT 11	812-458	018-007
2515-T11	5	TCMT 11	028-905	018-007
2615-T11	6	TCMT 11	028-905	018-007
2715-T11	7	TCMT 11	028-905	018-007
2815-T11	8	TCMT 11	028-905	018-007

STYLE 1: 3° INSERT HOLDERS

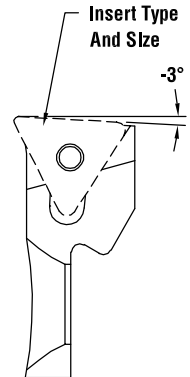

- Designed to allow boring into a corner. The -3° leads the insert into the workpiece with less tendency to deflect. Square shoulders, if required, are generally best produced utilizing the twin cutter with 0° lead insert holders during the roughing operation.

STYLE 2

Part Number	Insert Holder Size	Insert Type and Size	Insert Screw	Insert Screw Wrench
2210-T06	2	TCMT 06	028-910	018-002
2310-T06	3	TCMT 06	028-910	018-002
2410-T11	4	TCMT 11	812-458	018-007
2510-T11	5	TCMT 11	028-905	018-007
2610-T11	6	TCMT 11	028-905	018-007
2710-T11	7	TCMT 11	028-905	018-007
2810-T11	8	TCMT 11	028-905	018-007

STYLE 2: 0° LEAD INSERT HOLDERS

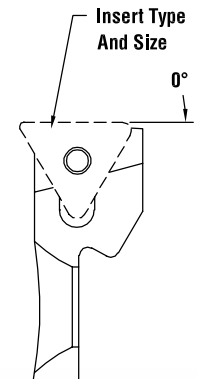

OPTIONAL EXTENDED REACH INSERT HOLDERS (STYLE 1)

Part Number	Boring Range (in) Min	Boring Range (in) Max	Boring Range (mm) Min	Boring Range (mm) Max	Fits Boring Head	Insert Type and Size	Insert Holder Size
2215-T06-157	1.254	1.570	32	40	PC2-2215 / PC2-2205	TCMT 06**	2
2215-T06-185	1.534	1.850	39	47	PC2-2215 / PC2-2205	TCMT 06**	2
2315-T06-200	1.586	2.000	40.5	50.5	PC3-2315 / PC3-2305	TCMT 06**	3
2315-T06-236	1.946	2.360	50	60	PC3-2315 / PC3-2305	TCMT 06**	3
2415-T11-248	1.968	2.480	50	63	PC4-2415 / PC4-2405	TCMT 11	4
2415-T11-291	2.398	2.910	60.5	74	PC4-2415 / PC4-2405	TCMT 11	4
2515-T11-322	2.551	3.220	65	81.5	PC5-2515 / PC5-2505	TCMT 11	5
2515-T11-374	3.071	3.740	78	95	PC5-2515 / PC5-2505	TCMT 11	5
2615-T11-496	3.637	4.960	92.5	126	PC6-2615 / PC6-2605	TCMT 11	6
2615-T11-590	4.577	5.900	116.5	150	PC6-2615 / PC6-2605	TCMT 11	6
2715-T11-704	4.977	7.040	126.5	178.5	PC6-2616 / PC7-2716 PC6-2606 / PC7-2706	TCMT 11	7
2715-T11-822	6.157	8.220	156.5	208.5	PC6-2616 / PC7-2716 PC6-2606 / PC7-2706	TCMT 11	7

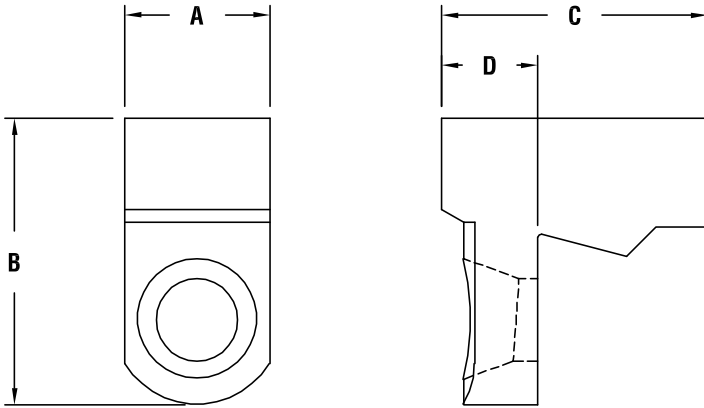

- After machining insert pocket, heat treat is recommended but not necessary. Heat treat per specifications below.
- Dimension "A" must be ground. Grind equally from both sides.
- Do not machine any of the seating surfaces.
- Insert pocket should be machined so that insert tip is .003 - .005 above center line of blank, after finish ground to "A" dimension.

Order Inserts, Insert Screws, and Wrenches Separately.

INSERT HOLDER BLANKS

Part Number	Quantity	Size/Type	A	B	C	D	Material	Case Hardened Recommendation
2215-BLANK	Single	2 Finish	.300	.71	.35	.14	1018	Rc: 50-54/.010 - .015 Deep
2315-BLANK	Single	3 Finish	.345	.78	.44	.18	1018	Rc: 50-54/.010 - .015 Deep
2415-BLANK	Single	4 Finish	.440	1.01	.57	.20	1018	Rc: 50-54/.010 - .015 Deep
2515-BLANK	Single	5 Finish	.550	1.21	.71	.30	1018	Rc: 50-54/.010 - .015 Deep
2615-BLANK	Single	6 Finish	.710	1.35	1.00	.45	1018	Rc: 50-54/.010 - .015 Deep
2715-BLANK	Single	7 Finish	.710	1.35	1.30	.47	1018	Rc: 50-54/.010 - .015 Deep
2815-BLANK	Single	8 Finish	.710	1.35	1.47	.47	1018	Rc: 50-54/.010 - .015 Deep

FINISH BORING HEAD

Part Number	Insert Holder Screw	Slide Lock Screw	Wrench	PC Pin
PC2-22(X)5	2215-01	029-082	018-102	PCP-002
PC3-23(X)5	2315-01	029-074	018-103	PCP-003
PC4-24(X)5	2415-01	029-091	018-104	PCP-004
PC5-25(X)5	2515-01	029-088	018-105	PCP-005
PC6-26(X)5	2615-01	029-094	018-106	PCP-006
PC6-26(X)6	2615-01	029-094	018-106	PCP-006

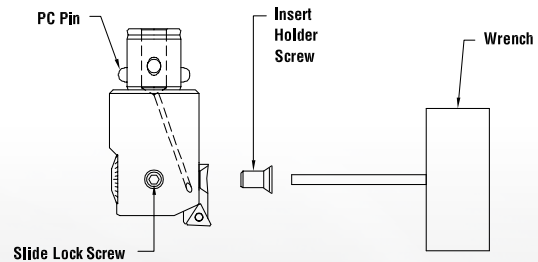

LARGE DIAMETER FINISHING

Part Number	Insert Holder Screw	Slide Lock Screw	Wrench
7100-28(X)6	2615-01	029-904	018-106

(X) refers to 1 or 0 (inch or metric).

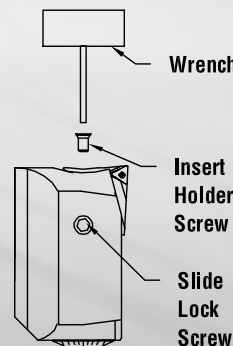



Extension base 17BR-7112 shown here with and without Insert Holders.

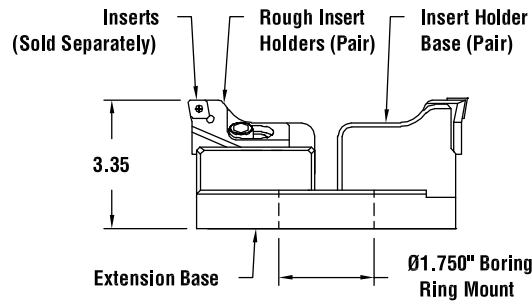

WEIGHTS

Part Number	Weight (lbs.)
SIZE 61	.6
SIZE 62	.8
SIZE 63	1.0

INSERT HOLDER STYLES

Style	Insert Type and Size	Insert Screw	Insert Screw Wrench
C	CCMT 12	028-907	018-009
S	SCMT 12	028-907	018-009
W	WCMX 08	028-906	018-008

See Page 19 for Insert Holders

EXTENSION BASE RANGES

Extension Base	BORING RANGE MIN AND MAX							
	Finish Head	Size 61 Insert Holder		Size 62 Insert Holder			Size 63 Insert Holder	
PC6-7108	5.95 (151)	8.27 (210)	5.95 (151)	6.80 (172)	6.68 (170)	7.52 (191)	7.42 (189)	8.27 (210)
17BR-7108	5.95 (151)	8.27 (210)	5.95 (151)	6.80 (172)	6.68 (170)	7.52 (191)	7.42 (189)	8.27 (210)
17BR-7110	8.22 (209)	10.54 (267)	8.22 (209)	9.07 (230)	8.95 (228)	9.79 (249)	9.69 (246)	10.54 (267)
17BR-7112	10.49 (267)	12.81 (325)	10.49 (267)	11.34 (288)	11.22 (285)	12.07 (306)	11.96 (304)	12.81 (325)
17BR-7115	12.76 (324)	15.08 (383)	12.76 (324)	13.61 (345)	13.49 (343)	14.34 (364)	14.23 (362)	15.08 (383)
17BR-7117	15.03 (382)	17.35 (441)	15.03 (382)	15.89 (403)	15.75 (400)	16.61 (422)	16.50 (419)	17.35 (441)
17BR-7119	17.30 (439)	19.62 (498)	17.30 (439)	18.15 (461)	18.03 (458)	18.88 (479)	18.77 (477)	19.62 (498)



LARGE DIAMETER



Extension Base with Finish Head shown here.

- Finish bore full range of extension base.
- Uses modular extension base to minimize tooling inventory.
- Diameter adjustment of .0001 with vernier scale.
- .040 per revolution, .001 (.02 mm) on diameter dial.

BORING HEAD INSERT SIZE & WEIGHT

Part Number	Insert	Insert Holder Size	Weight lbs.	Description
7100-2806	TCMT 11	8	4.3	Finish Head Metric
7100-2816	TCMT 11	8	4.3	Finish Head Inch
7100-B460	TCMT 11	61, 62, 63	2.8	Rough Insert Holder Base
816-009	TCMT 11	-	.7	Counter Weight

See page 19 for Twin Bore Insert Holders.

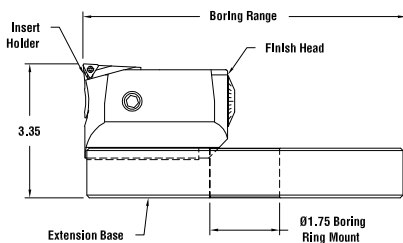

MODULAR BORING RING HOLDERS



Boring Ring Holder PC7-17BR2 shown here.

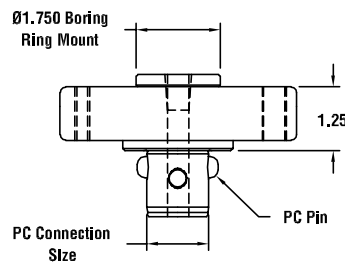

MODULAR BORING RING HOLDERS

Part Number	PC Connection	Weight lbs.
PC6-17BR2	PC6	6.5
PC7-17BR2	PC7	7.1

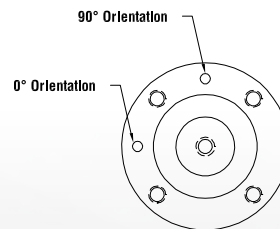

BORING RING ADAPTERS

- Integral shank for non-modular applications.

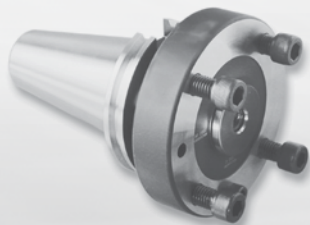

Boring Ring Holder PC7-17BR2 shown here.

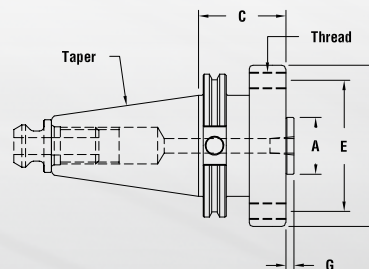

Order Retention Knob Separately (See pages 54–57)

BORING RING ADAPTERS

Part Number	A Dia.	B Dia.	C	E	G	Thread	No. of Threads	Weight lbs.
C50-17BR2*	1.750	4.94	2.50	4.00	.250	1/2-13	4	13.7
C50-17BR5*	1.750	4.94	5.00	4.00	.250	1/2-13	4	21.9

*Includes 90° tool tip orientation for clearance of oversize boring tools in carousels.



A large, empty rectangular area with rounded corners, intended for handwritten notes or technical drawings related to the boring process.



RETENTION KNOBS



ANSI Type
40TRK shown here.



MAS BT Type
4001TRK shown here.



DIN Type
DIN50ATRK shown here

NEW! As part of Parlec's ongoing initiative to improve our product's performance, all retention knobs now have a piloted design.

Parlec offers retention knobs for over 100 styles of machine tools

- Material, heat treat, and dimensions are to ANSI specifications.
- Manufactured using alloy steel.
- Case hardened to ensure long service life.
- Core is tempered for tough shock resistance.

WARNING: Machine tool manufacturers have used many various styles and sizes of retention knobs. They often look very similar and appear to be interchangeable. The use of the incorrect knob, or the incorrect use of a knob, may result in injury or property damage. It is the responsibility of the end user to check that the supplied knobs are correct for the machine tool and taper type.

It is very important not to intermix metric retention knobs with inch toolholders. Be sure to fully tighten the retention knob. Failure to do so may result in the toolholder coming loose during operation.

The use of a sealing and or thread lock is recommended. Overtightening may cause a toolholder taper deformation.

Ordering Instructions:

Please provide a drawing of your knob or supply the information on the retention knob quotation request sheet on page 130.



40TRK shown here.

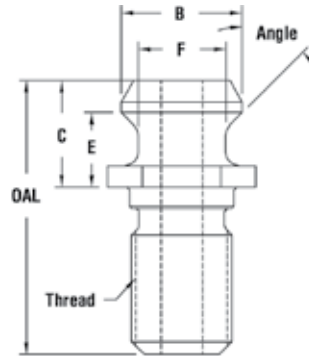

ANSI/ISO RETENTION KNOBS

Part Number	Thread	Angle	OAL	B	C	E	F	Coolant Hole	Specification/Feature
40NTRK	5/8 - 11	45	1.68	.740	.640	.440	.490	-	ANSI STD Solid
40TRK	5/8 - 11	45	1.68	.740	.640	.440	.490	.281	ANSI STD
50NTRK	1 - 8	45	2.54	1.140	1.000	.700	.820	-	ANSI STD Solid
50TRK	1 - 8	45	2.54	1.140	1.000	.700	.820	.468	ANSI STD
A40TRK	M16 - 2	45	1.65	.740	.640	.440	.490	.281	ANSI For Metric Shank
A50TRK	M24 - 3	45	2.58	1.140	1.000	.700	.820	.468	ANSI For Metric Shank
M50TRK	1 - 8	45	2.30	1.140	1.000	.700	.820	.468	MAZAK O-Ring Seal Groove



DIN50ATRK shown here.

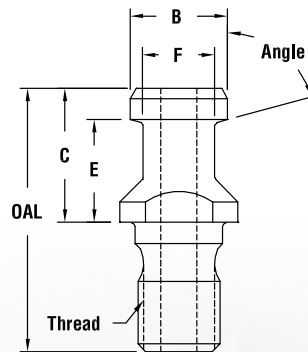

DIN RETENTION KNOBS

Part Number	Thread	Angle	OAL	B	C	E	F	Coolant Hole	Specification/Feature
4030TRK	5/8 - 11	75	2.06	.747	1.020	.788	.550	.281	DIN For Inch Shank
5030TRK	1" - 8	75	2.88	1.100	1.345	.990	.827	.468	DIN For Inch Shank
DIN40ATRK	M16 - 2	75	2.12	.747	1.024	.788	.549	.276	DIN STD Coolant

Other sizes available upon request. Please call Parlec or your local Parlec representative for more information.



4009TRKC shown here.

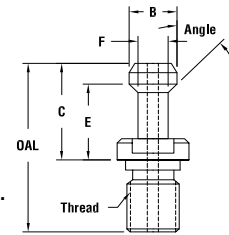

MAS BT RETENTION KNOBS

Part Number	Thread	Angle	OAL	B	C	E	F	Coolant Hole	Specification/Feature
3001TRK	1/2-13	45	1.42	.393	.787	.630	.236	-	CHIRON INCH SHANK
3002TRK	M12-1.75	45	1.42	.393	.787	.630	.236	-	CHIRON METRIC SHANK
3003TRK	M12-1.75	45	1.70	.430	.908	.710	.273	-	MAS BT 45 DEG
3003TRKC	M12-1.75	45	1.70	.430	.908	.710	.273	.125	MAS BT 45 DEG
3004TRK	M12-1.75	60	1.70	.430	.908	.710	.273	-	MAS BT 60 DEG
4001TRK	5/8-11	90	2.32	.588	1.275	.988	.393	-	-
4001TRKC	5/8-11	90	2.32	.588	1.275	.988	.393	.197	-
4002TRK	M16-2	90	2.36	.588	1.376	1.102	.393	-	MAS BT 90 DEG
4003TRK	M16-2	45	2.36	.588	1.376	1.102	.393	-	MAS BT 45 DEG
4003TRKC	M16-2	45	2.36	.588	1.376	1.102	.393	.197	-
4004TRK	M16-2	60	2.36	.588	1.376	1.102	.393	-	MAS BT 60 DEG
4005TRK	5/8-11	45	2.31	.588	1.268	.988	.393	-	-
4005TRKC	5/8-11	45	2.31	.588	1.268	.988	.393	.157	-
4008TRK	5/8-11	75	2.06	.744	1.024	.787	.549	-	-
4008TRKC	5/8-11	75	2.06	.744	1.024	.787	.549	.276	-
4009TRK	5/8-11	45	2.30	.588	1.264	.990	.393	-	-
4009TRKC	5/8-11	45	2.30	.588	1.264	.990	.393	.197	-
4010TRK	5/8-11	75	2.13	.748	1.142	.906	.551	.276	-
4014TRK	5/8-11	60	2.31	.588	1.268	.990	.393	-	-
4014TRKC	5/8-11	60	2.31	.588	1.268	.990	.393	.197	-
4020TRK	M16-2	15	2.26	.748	1.142	.905	.550	.276	-
5001TRK	1-8	90	3.31	.904	1.770	1.378	.667	-	-
5001TRKC	1-8	90	3.31	.904	1.770	1.378	.667	.250	-
5002TRK	M24-3	90	3.34	.904	1.770	1.378	.667	-	MAS BT 90 DEG
5003TRK	M24-3	45	3.34	.904	1.770	1.378	.667	-	MAS BT 45 DEG
5003TRKC	M24-3	45	3.34	.904	1.770	1.378	.667	.250	-
5004TRK	M24-3	60	3.34	.904	1.770	1.378	.667	-	MAS BT 60 DEG
5005TRK	1-8	45	3.33	.904	1.791	1.378	.667	-	-
5005TRKC	1-8	45	3.33	.904	1.791	1.378	.667	.250	-
5014TRK	1-8	60	3.31	.904	1.770	1.378	.667	-	-
5014TRKC	1-8	60	3.31	.904	1.770	1.378	.667	.250	-
5021TRK	1-8	90	2.77	.940	1.234	.907	.708	-	-
C400TRK	5/8-11	45	2.48	.588	1.436	1.137	.406	-	-
C400TRKC	5/8-11	45	2.48	.588	1.436	1.137	.404	.157	-
F40TRK	M16-2	45	1.85	.740	.752	.552	.490	-	FADAL BT40
M400TRK	5/8-11	90	1.91	.588	1.053	.777	.393	-	-
MAK050TRK	1-8	45	3.14	.904	1.780	1.386	.667	.236	MAKINO
MH500TRK	1-8	90	2.32	.904	1.780	1.386	.667	-	-
MS5034TRK	1-8	90	2.76	.940	1.218	.903	.706	.315	-
MZ40TRK	M16-2	45	1.85	.740	.752	.552	.490	.281	FADAL BT40

Other sizes available upon request. Please call Parlec or your local Parlec representative for more information.



QUOTATION REQUEST SHEET

CONTACT INFORMATION For quick response, just photocopy this page, complete all information (please include Part Print where appropriate) and simply FAX back to Parlec at 1-800-866-5917

Company _____

Contact Name _____ Title _____

Business Address _____ City _____ State _____ Zip _____

Phone _____ Fax _____ Email _____

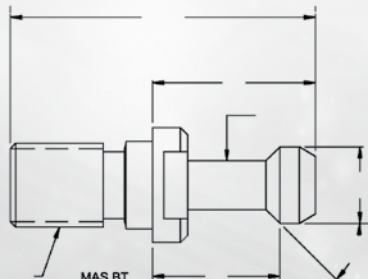
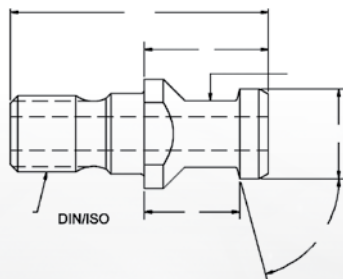
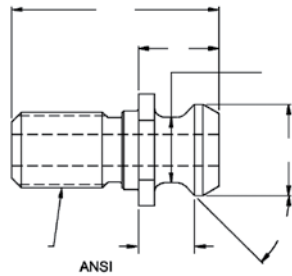

If required knob is not shown, please select the most similar design and specify dimensions.

MACHINE CENTER INFORMATION

Machine Make _____

Machine Model _____

Taper Size _____

Coolant Hole Diameter _____

Hole Through Partial Hole No Hole

Special Features _____

Request for Quotation



Visit Us Online www.parlec.com

Be sure to check out other solutions that Parlec offers.

Precision Modular Boring



ER Toolholding System
SimulFit® Toolholding Solutions
Evolution Line Angle Heads
ERos® Toolholding Systems



Tapping Solutions



Process, Automate, Connect
Parlec Tool Measuring Machine - TMM®



For a complete listing of Parlec literature visit us at www.parlec.com

PARLEC

BY ANY MEASURE

Measurably Better



PARLEC | BY ANY MEASURE
Measurably Better

Americas

Tel: 585-425-4400
Fax: 585-425-7542

Asia Pacific

Tel: 86-25-8711-3188
Fax: 86-25-8711-3180

Europe

Tel: 01-585-425-4400
Fax: 01-585-425-7542

Headquarters

101 Perinton Parkway
Fairport, NY 14450 USA

For a quotation, please contact 1-800-TOOL-USA (1-800-866-5872) or visit www.parlec.com.

