

VARDEX

Advanced Threading Solutions

MAIN CATALOG

Thread Turning

Thread Milling

INCH

VARGUS is a world leading developer, manufacturer and supplier of high-quality, precision threading, grooving, turning and hand deburring tools.

Established in 1960, VARGUS is the cutting tools division of the NEUMO Ehrenberg Group, a multinational organization headquartered in Germany.

With 13 international subsidiaries, and a network of distributors, warehouses and certified ISO 9001 manufacturing facilities, VARGUS Ltd. serves customers in more than 100 countries around the globe. A customer-focused organization, VARGUS Ltd. is committed to providing products and solutions of the highest quality and excellent value, and is renowned for its technical expertise and uncompromising service.

COMPANY PRODUCTS:

VARDEX
Advanced Threading Solutions is the company's prominent product line for Thread Turning, Thread Milling, and Gear Milling Solutions.

Thread Turning: The VARDEX TT tools offer an extensive collection of pitches and standards in different grades, IC ranges and types of insert styles, as well as customized methods for the oil and gas industry.

Thread Milling: The VARDEX TM line provides a wide range of applications and solutions in multi-tooth, single-tooth for deep holes, and solid carbide tools.

Gear Milling: The VARDEX Gear Milling line is a revolutionary concept for gear, rack and spline applications, offered in indexable inserts and solid carbide tools.

VARGUS GENius™: VARGUS' industry-leading Thread Turning and Thread Milling solutions are seamlessly complimented by the VARGUS GENius™ software – The most powerful tool selector, cutting data and CNC program generating software.

GROOVEX
Innovative Grooving & Turning Solutions, the newest product line by VARGUS, provides innovative solutions for grooving, boring and turning, in a wide range of applications.

SHAVIV
Leading Deburring Solutions, manufactures world leading hand-deburring solutions for metals and plastics.





FLINE

Fixed Clamping System



VRX

Multipurpose Premium Grade

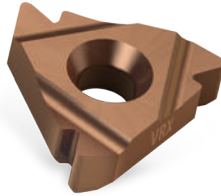

MEGALINE

For Extra Large Pitches



V-CAP Toolholders

Polygon Shaped Shanks



Oil&Gas

Professional Threading Solutions



Mini-3 IC 5.0

Tools for Small Applications

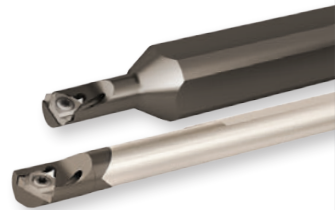

VG-Cut

Machining Between Shoulders

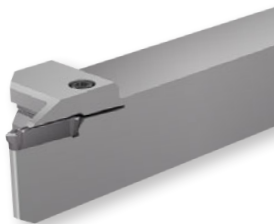

Mini-V

Miniature Vertical Tools



TMSD Vertical

Multi-Flute Vertical Tools

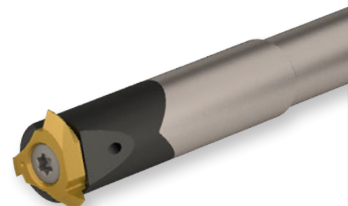

Contents

THREAD TURNING

Thread Turning System.....	12
----------------------------	----



Thread Turning Inserts..... 17

Vardex Ordering Code System.....	18
Partial Profile 60°	21
Partial Profile 55°	28
ISO Metric.....	34
American UN.....	49
American UNR.....	62
Whitworth	63
BSPT	73
NPT	76
ANPT.....	82
NPTF	83
NPS.....	87
Round (DIN 405)	88
Round (DIN 20400).....	89
Trapez.....	93
American ACME.....	101
American ACME (2G)	108
Stub ACME	110
UNJ.....	115
MJ.....	120
American Buttress.....	122
British Buttress.....	126
Metric Buttress (Sägengewinde)	127
API.....	132
API Buttress Casing.....	134
API Round Casing & Tubing.....	138
VAM.....	144
New VAM.....	146
EL-Extreme Line.....	148
Hughes H-90.....	149
Pg.....	150



Thread Turning Toolholders 153

Vardex Ordering Code System.....	154
----------------------------------	-----

External Toolholders

Standard	156
Standard F-Line	157
V-CAP.....	157
Standard with Clamp.....	158
Oil & Gas.....	159
U Style	160
U Style with Clamp.....	160
Slim Throat.....	161
VG-Cut.....	162
V Style.....	163
Z+ Style	163
M+ Style.....	164
F-Line M+ Style.....	164
T+ Style.....	165
14D Standard.....	165
Off-Set Qualified (FQ).....	166
Drop Head-Qualified (CQ)	166
Miniature Square Shank.....	167
Miniature Round Shank.....	167

Internal Toolholders

Standard	168
Standard F-Line	169
V6 Style	169
V-CAP.....	170
Standard for Coarse Pitch.....	171
U Style for Coarse Pitch	171
Standard with Clamp.....	172
U Style	173

U style with Clamp	174
V Style	174
Z+ Style	175
M+ Style	175
F-Line M+ Style.....	176
T+ Style.....	176
14D Standard.....	177
14D Standard with Clamp.....	177
Oil & Gas.....	178
Standard with Carbide Shank.....	179
Mini-V	180
Mini-3 Standard.....	184
Mini-3 U Style	185
Mini-3 Adjustable.....	186
Mini-L.....	186
Mini-L Adjustable	187
Micro - Double Ended.....	187
Microscope - Single Ended.....	188



TT Technical Data..... 193

Thread Terminology	194
Machining a Multi-Start Thread.....	195
Insert Profile Styles	195
Thread Turning Methods for Symmetrical Inserts	196
Thread Infeed Methods.....	196
Thread Turning Methods for Asymmetrical Inserts	197
Calculating the Helix Angle	198
Anvils.....	199
Oil & Gas Anvils.....	200
Anvil Kits	200
Spare Parts.....	201
Grades and Their Applications.....	202
Recommended Grades and Cutting Speeds.....	204
Cutting Conditions Parameters.....	208
Number of Passes	209
Depths of Cut and Number of Passes for Mini-V.....	209
Number of Passes and Depth of Cut for Multi+	210
Step by Step Thread Turning.....	212

Material Comparison Table	216
Troubleshooting	220

THREAD MILLING

Thread Milling Systems	224
Thread Milling Methods.....	226
The Thread Milling Advantages	227



MiTM..... 229

Vardex Ordering Code System.....	230
----------------------------------	-----

MiTM Inserts

ISO Metric.....	232
American UN.....	233
Whitworth	235
NPT	236
NPTF	236
BSPT.....	237
Plug Insert.....	237

MiTM Toolholders

Standard Toolholders (MiTM 19).....	238
Conical Toolholders (MiTM 19)	239
Standard Toolholders (MiTM 24).....	240
Conical Toolholders (MiTM 24)	241
Standard Toolholders (MiTM 25).....	242
Conical Toolholders (MiTM 25)	243
Shell Mill (MiTM 25).....	244
Standard Toolholders (MiTM 40).....	245
Shell Mill (MiTM 40).....	246
Standard Toolholders (MiTM 41).....	247
Shell Mill (MiTM 41).....	248
Recommended Grades, Cutting Speeds and Feed	249



STANDARD Thread Milling..... 251

Vardex Ordering Code System.....	252
----------------------------------	-----

Standard Inserts

ISO Metric.....	254
American UN.....	259
UNJ.....	266
Whitworth	267
NPT.....	271
NPTF (Dry Seal).....	272
NPS.....	273
BSPT.....	274
Pg.....	275
ACME	276
Trapez.....	277

Standard Toolholders

TM Standard.....	278
TML Long Tools.....	280
124/... - For Coarse Pitch Threads.....	282
TMN - For Conical Threads.....	284
TM2 - Twin Flutes	286
TMO - Twin Flute Offset	287
TM Shell Mill	288
TMS - Single Point (Standard Inserts).....	290
TMV - Single Point (Vertical Insert).....	290
Recommended Grades, Cutting Speeds and Feed	291



TMSD.....293

Vardex Ordering Code System.....	294
----------------------------------	-----

TMSD Vertical Inserts

Partial Profile 60°.....	296
Partial Profile 55°.....	297
Trapez.....	298
Stub ACME	298

TMSD Vertical Toolholders

Vertical Toolholders Weldon Shank	299
Vertical Toolholders Carbide Cylindrical Shank.....	300

TMSD Inserts

Partial Profile 60°.....	301
Partial Profile 55°.....	302
ISO Metric.....	303
American UN.....	304
NPT.....	305
Trapez.....	306
American ACME.....	307
Stub ACME	307
American Buttress.....	308
API Round Casing & Tubing.....	309

TMSD Toolholders

Standard Toolholders Weldon Shank (U Style).....	310
Standard Toolholders Carbide Cylindrical Shank (U Style).....	312
Standard Toolholders Steel Cylindrical Shank (U Style).....	314
Shell Mill (U Style)	316
Standard Toolholders Weldon Shank (L Style - Mini L).....	318
Standard Toolholders Carbide Cylindrical Shank (L Style - Mini L).....	320
Standard Toolholders Weldon Shank (L Style - 3/8" L).....	322
Standard Toolholders Carbide Cylindrical Shank (L Style - 3/8" L).....	323
Shell Mill (L Style - 3/8" L).....	324
Shell Mill (5/8" V Style).....	325
Standard Toolholders Steel Cylindrical Shank (A Style).....	326
Recommended Grades, Cutting Speeds and Feed	327



TM Solid.....329

Vardex Ordering Code System.....	330
Helicool	332
Helicool-R (HCR).....	339
Helicool-C (HCC).....	340
HTC (Thriller)	341
He-Lex.....	342
Deep Threading	346

MilliPro	348
MilliPro Dental.....	352
MilliPro EL.....	353
MilliPro HD.....	354
Straight	356
Recommended Grades, Cutting Speeds and Feed	364



TM Technical Data.....367

About Thread Milling.....	368
Preparing for the Thread Milling Operation.....	370
List of "G" Codes (ISO) for CNC Program.....	371
Minimum Bore Diameters for TM Standard line	372
Spare Parts.....	374
Troubleshooting	376

MINI PRO



MiniPro Inserts.....379

Vardex Ordering Code System.....	380
----------------------------------	-----

PowerBore Inserts

CD0W Inserts	381
TD0W Inserts.....	381
WC0W Inserts	382

Micro Boring Inserts

Micro Boring - Boring	383
Micro Boring - Copy.....	384
Micro Boring - Chamfer.....	384
Micro Boring - Long Nose.....	385
Micro Boring - Back Boring.....	386
Micro Boring - Boredrill.....	386

Micro Grooving Inserts

DIN 472 Retaining Ring Grooves for Bores	387
CIRCLIP Inch Standard.....	389

DIN 7993 Snap Ring Grooves.....	391
Snap Ring Grooves.....	392
DIN 3770 - Grooves	393
CIRCLIP - Face Grooves	393



MiniPro Toolholders.....395

Vardex Ordering Code System.....	396
PowerBore Toolholders.....	397
Micro Toolholders	401



MiniPro Technical Data.....403

Recommended Grades, Cutting Speeds and Feed	404
Spare Parts.....	405

VARGUS GENius™ – The most powerful tool selector, cutting data and CNC program generating software for the metal cutting tools industry.

Thread Turning: The Vargus GENius™ guides the user to the right tool and the best cutting conditions for the application.

Thread Milling: In a few simple steps, the Vargus GENius™ provides the user with the best tool and optimal machining data, as well as the G-Code for all popular CNC machines.

The VARGUS GENius™ is free and available in 16 languages in iOS and Android Apps, Online, Desktop, and SETUP versions.

VARGUS GENius™ | Tool Selector and CNC Program Generator

Anywhere! Anytime!

The most popular and advanced thread turning and thread milling software on the market today.



Available in 4 versions at www.vargus.com



- Online interactive software
- Always on, always updated!



- Stand-alone software application
- MS Windows OS-based program
- Automatic updates



- USB memory devices
- MS Windows operating system-based program
- To install, open ZIP and click Setup



- Available for iOS and Android devices
- New responsive design!
- Use on any device, anywhere in the world!

Whether you require a non-standard size, a complex shape or a special design, the Vargus Custom Made Solutions team has the experience and know-how for essentially any tooling solution.

Working closely with the customer, VARGUS engineers provide the best solution for your operation, as well as guide and advise in the implementation of the customized machining process.

The Custom Made Solutions team has all of the know-how to design the right cutting tool, using the latest techniques and top-of-the-line technology.

Contact your VARGUS Sales Representative for more details.



Quality | Innovation | Service

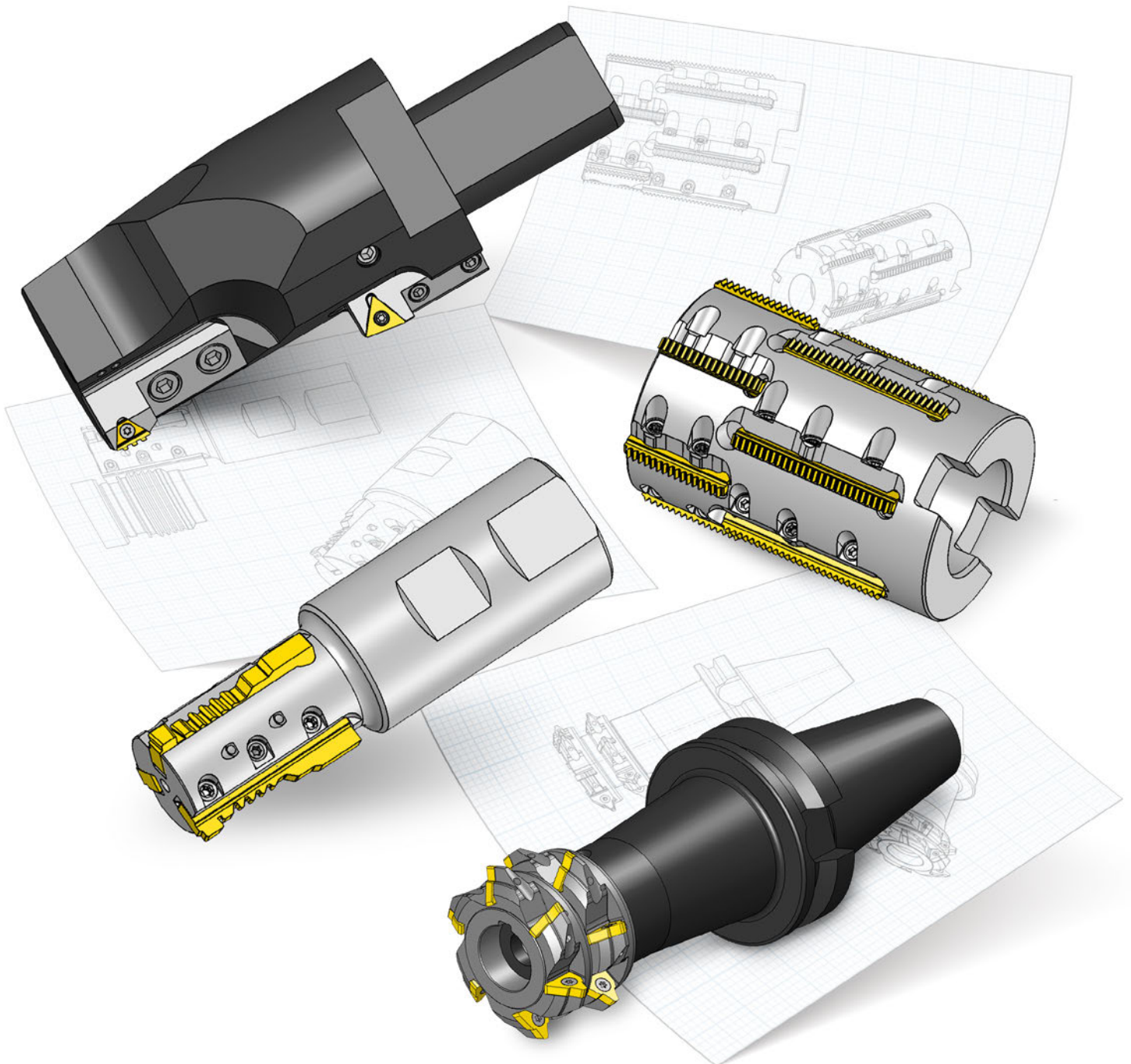

GEAR MILLING

Advanced Technologies for Gear, Spline and Rack Manufacturing



Revolutionary and cost-effective solutions for Gear, Spline & Rack applications, tailor-made to order or available as standard for Spline.

The complete Gear Milling Product Catalog is available at www.vargususa.com



Gear Milling Tool Range



End Mill

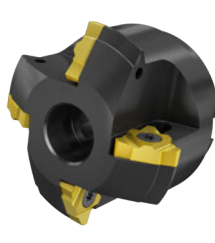

Shell Mill



Disc Mill

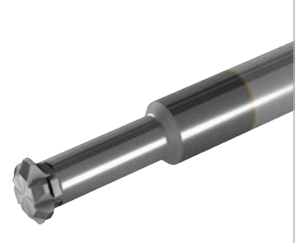

Solid Carbide



THREAD TURNING

■ Inserts	17
■ Toolholders	153
■ Technical Data	193

Thread Turning System - EXTERNAL

Standard



V6



SCB

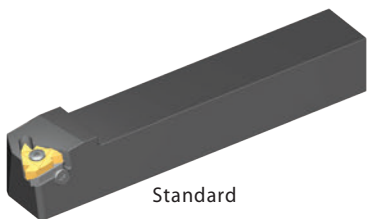

Standard

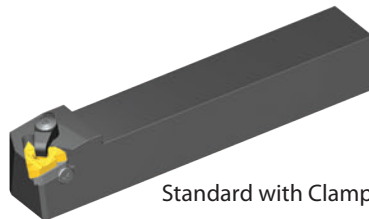

Standard with Clamp



V-Cap

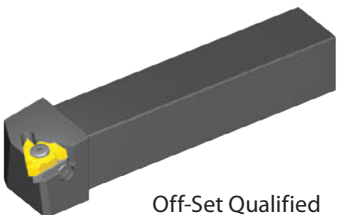

Off-Set Qualified

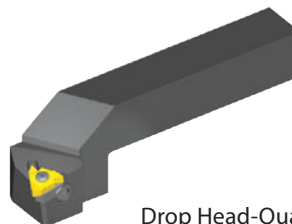

Drop Head-Qualified

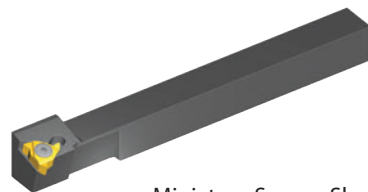

Miniature Square Shank



Miniature Round Shank

FLINE



IC 1/2\"/>

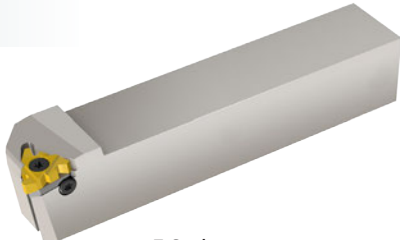

F Style

U Style

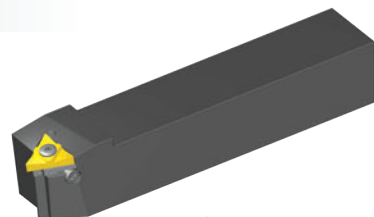

U Style

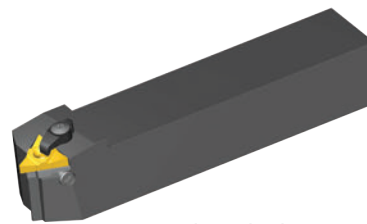

U Style with Clamp

V Style

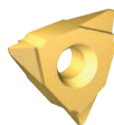

1/4\"/>

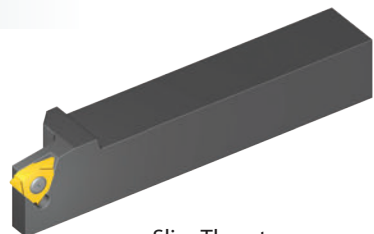

Slim Throat

VG-Cut

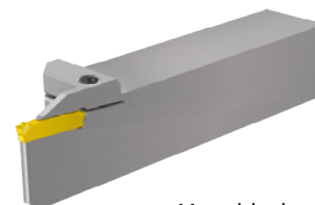

Monoblock

Thread Turning System - EXTERNAL



V Style



5/8"V

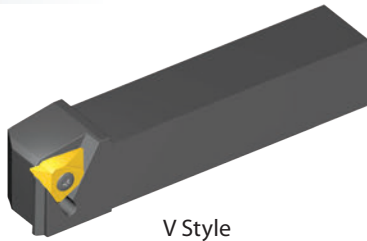

V Style

MEGALINE



5/8"MG



MG Style

Multiplus

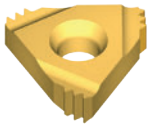

M+ Style

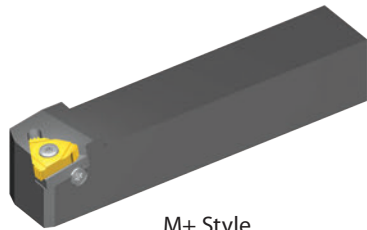

F-LINE



MF+ Style



Z+ Style

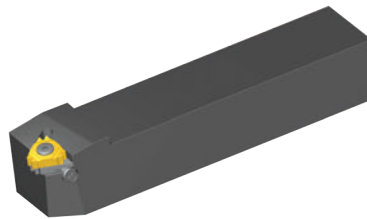

T+ Style

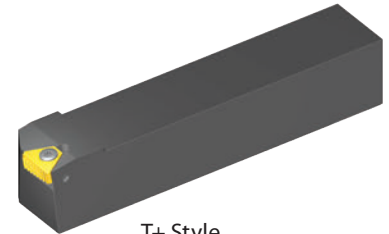

Oil&Gas

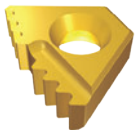

14D

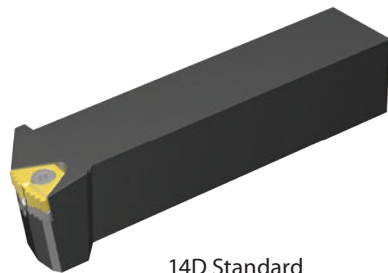

14D Standard

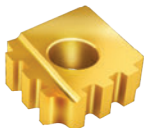

CNGA

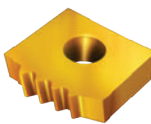

Chaser



T+ Style



On Edge

Thread Turning System - INTERNAL

Standard

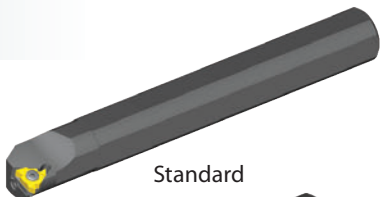

Standard

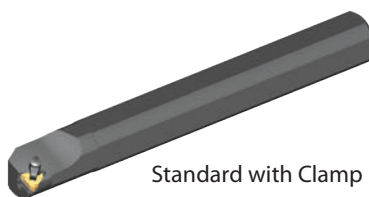

Standard with Clamp



V-Cap



6°

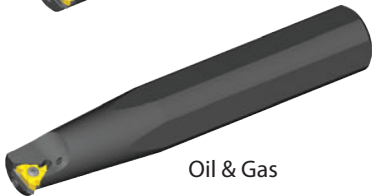

Oil & Gas

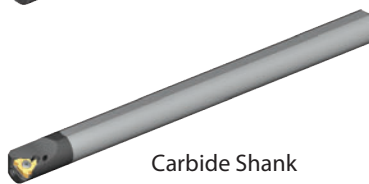

Carbide Shank



SCB

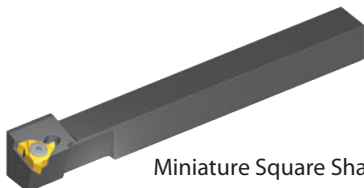

Miniature Square Shank



Miniature Round Shank

FLINE



F Style

U Style

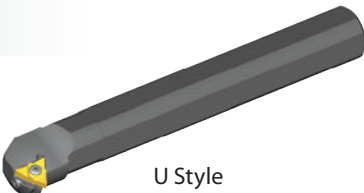

U Style

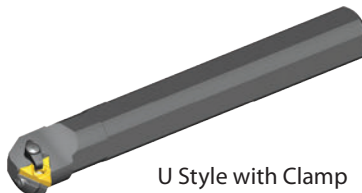

U Style with Clamp

V Style



5/8"V

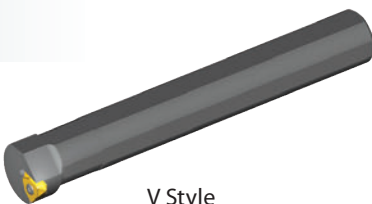

V Style

MEGALINE

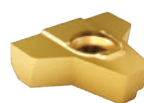

5/8"MG



MG Style

Multiplus

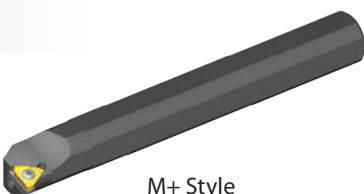

M+ Style



FLINE



MF+ Style

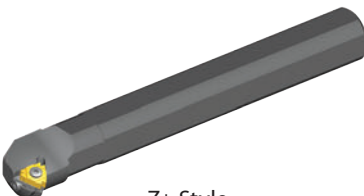

Z+ Style

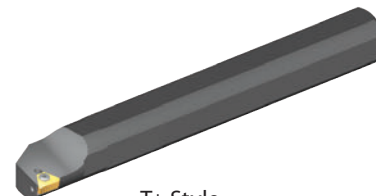
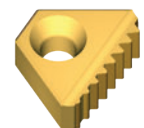

T+ Style

Thread Turning System - INTERNAL

Mini-V



Steel Shank

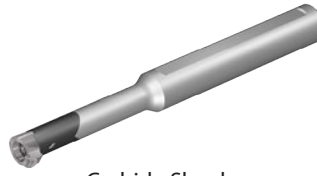

Carbide Shank



Sleeve Clamping Shank

MINIPRO



Mini-3
 IC 4.0, IC 5.0, IC 6.0



Steel Shank /
 Carbide Implanted Shank



Mini-3 Adjustable



Carbide Shank



Mini-5L



Steel Shank /
 Carbide Implanted Shank

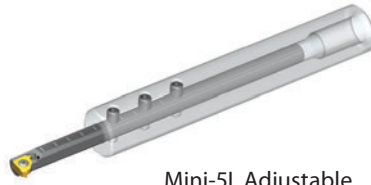

Mini-5L Adjustable

MINIPRO

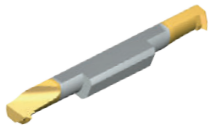

Micro Double-Ended

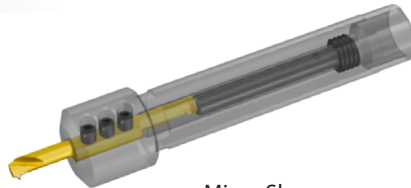

Micro Sleeve

microscope

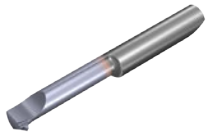

Micro Single-Ended



2 Flats Round Shank



4 Flats Round Shank



Square Shank



Drop Head

Oil&Gas



14D



14D

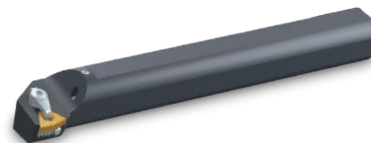

14D with Clamping

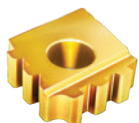

CNGA

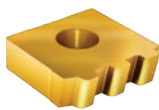

Chaser



T+ Style



On Edge

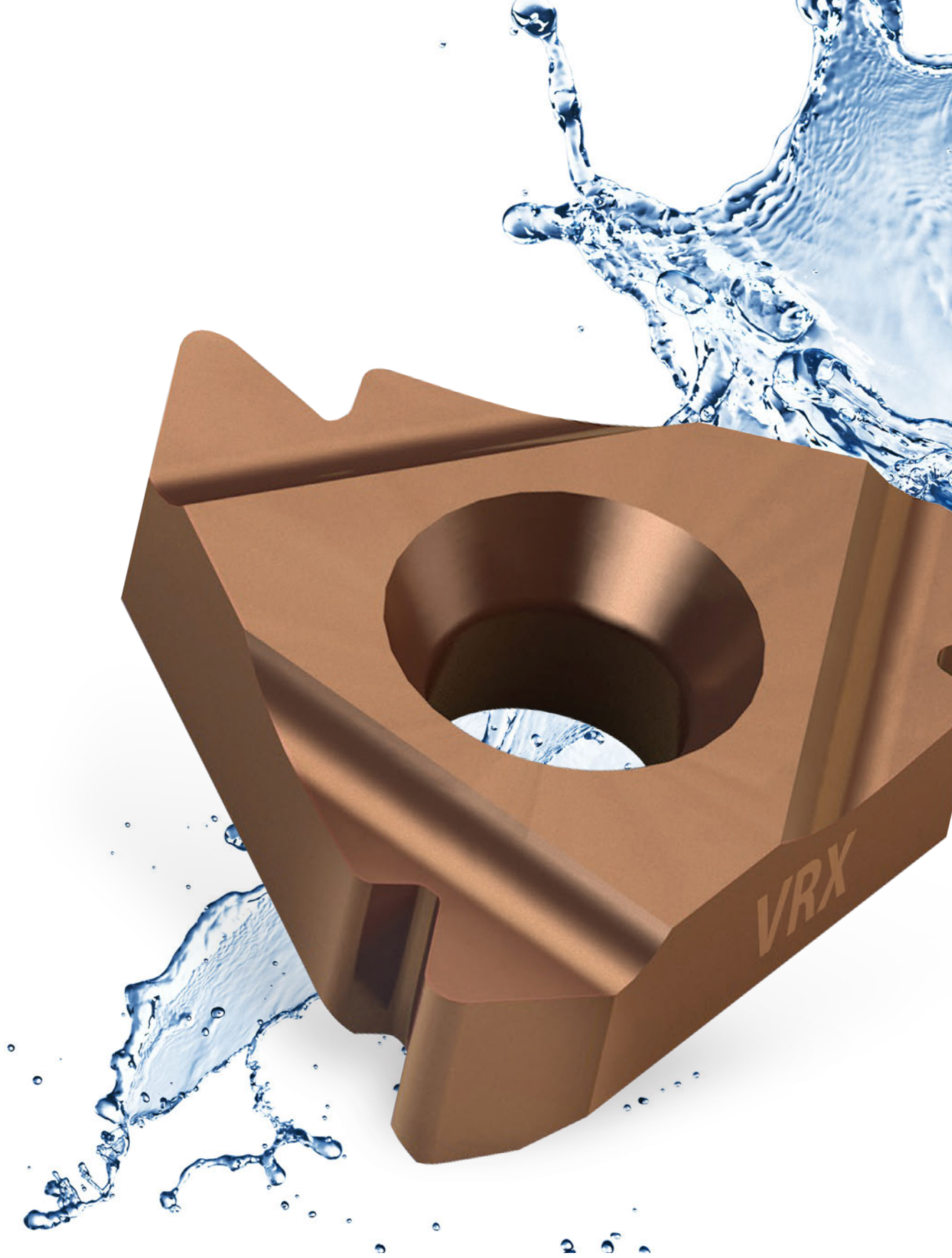

Thread Turning Inserts

Vardex Ordering Code System

■ Threading Inserts



3		E	R	12	UN					VTX	
1	2	3	4	5	6	7	8	9	10	11	12

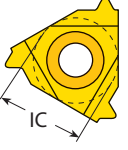

1 - Insert Size

5LK - IC5.0L mm
 4.0K - IC4.0 mm
 5.0K - IC5.0 mm
 6.0K - IC6.0 mm
 2 - IC1/4"
 3 - IC 3/8"
 4 - IC 1/2"
 5 - IC5/8"
 14D - 14D
 1616 - Chaser size 16x16mm



2 - Insert Style

U  V  MG 
 U Style Vertical Mega Line

L  J  F 
 Mini-L SCB F-Line

3 - Type of Insert

E - External
 I - Internal
 EI - External + Internal

4 - RH/LH Insert

R - Right Hand Insert
 L - Left Hand Insert
 None - Right + Left Insert

5 - Pitch

Full Profile - Pitch Range	
mm	TPI
0.35-25.0	72-1
Partial Profile - Pitch Range	
mm	TPI
A 0.5 - 1.5	48 - 16
B 1.75 - 2.0	14 - 11
AG 0.5 - 3.0	48 - 8
G 1.75 - 3.0	14 - 8
N 3.5 - 5.0	7 - 5
U 5.5 - 8.0	4.5 - 3.25
Q 5.5 - 6.0	4.5 - 4
U 6.5 - 9.0	4 - 2.75
V 6.0 - 10.0	4 - 2.5
S 0.5 - 2.0	48 - 13

6 - Standard

60 - Partial Profile 60°	STACME - Stub ACME
55 - Partial Profile 55°	UNJ - UNJ
ISO - ISO Metric	MJ - ISO 5855
UN - American UN	ABUT - American Buttress
UNR - American UNR	BBUT - British Buttress
W - Whitworth for BSW, BSP	SAGE - Metric Buttress DIN 513
BSPT - British Standard Pipe Thread	API - API
NPT - NPT	BUT - API Buttress Casing
ANPT - ANPT	APIRD - API Round Casing & Tubing
NPTF - NPTF	VAM - VAM
NPS - NPS	NVAM - New Vam
RD - Round DIN 405	EL - Extreme Line Casing
RD20400 - Round DIN 20400	H90 - H90
TR - Trapez DIN 103	PG - Pg DIN 40430
ACME - ACME	

7 - No. of Cutting Corners

6C - V6 Cutting Corners





8 - API Form

382
383
403
502
503
652

9 - No. of Teeth

(for Multitooth Style)
 2, 3, 5, 6, 8

10 - Multitooth Style

M+  T+ 
 Z+  S+ 

Multi^{plus}

11 - Coarse Pitch Inserts

158/...

12 - Carbide Grade

VKX, VTX, VCB, VM7, VK2, VK2P,
 VHX, VBX, VRX, VTXP, VKXP, VRXP

■ Micro Threading Inserts - Double Ended

3	S	I	R	0.5	ISO	VMX	
1	2	3	4	5	6	7	
1 - Insert Dia.	2 - Insert Style		3 - Type of Insert		4 - RH/LH Insert		5 - Pitch
3.0 - 3.0 mm 4.0 - 4.0 mm 6.0 - 6.0 mm 8.0 - 8.0 mm 10.0 - 10.0 mm	S - Micro Insert		I - Internal		R - Right Hand Insert L - Left Hand Insert		Full Profile - Pitch Range
							mm TPI
							0.30-1.5 40-16
							Partial Profile - Pitch Range
							mm TPI
							A 0.5 - 1.5 A 48 - 16
							F 0.5 - 3.0 F 48 - 24
6 - Standard	7 - Carbide Grades						
60 - Partial Profile 60° 55 - Partial Profile 55° ISO - ISO Metric MJ - ISO 5855 NPT - NPT NPTF - NPTF UN - American UN W - Whitworth for BSW, BSP	VMX						

microscope

■ Micro Threading Inserts - Single Ended

M	5	42	TH	0.5	ISO	L16	R	VBX
1	2	3	4	5	6	7	8	9
1 - Product Line	2 - Insert Size [mm]		3 - Min. Bore Dia. [mm]					
M, MS - Microscope	4, 5, 6, 7		3,2, 4,2,...					
4 - Type of Application	5 - Pitch (for Threading)			6 - Threading Standard				
TH - Threading	Full Profile - Pitch Range			60 - Partial Profile 60° 55 - Partial Profile 55° ISO - ISO Metric UN - American UN W - Whitworth for BSW, BSP NPT - NPT				
	mm TPI							
	0.5-1.5 32-16							
	Partial Profile - Pitch Range							
	mm TPI							
	A	0.5 - 1.5	A	48 - 16				
	F	0.5 - 1.0	F	48 - 24				
7 - Overhang [mm]	8 - LH or RH			9 - Carbide Grades				
L16	R - RH Helix L - LH Helix			VBX				

■ CNGA and On Edge Inserts for Oil & Gas

C	N	G	A	6	4	I	R	5	BUT75	VKX
T	N	E	C	4	3	E	R	4	APIRD	VKX
1	2	3	4	5	6	7	8	9	10	11

1 - Insert Shape	2 - Clearance Angle on Major Cutting Edge	3 - Tolerances	4 - Clamp Type												
		<table border="1"> <tr> <th>IC</th> <th>S</th> <th>m</th> </tr> <tr> <td>Theoretical diameter of inscribed circle</td> <td>Insert thickness</td> <td></td> </tr> <tr> <td>E</td> <td>±0.025 mm</td> <td>±0.025 mm</td> </tr> <tr> <td>G</td> <td>±0.025 mm</td> <td>±0.13 mm</td> </tr> </table>	IC	S	m	Theoretical diameter of inscribed circle	Insert thickness		E	±0.025 mm	±0.025 mm	G	±0.025 mm	±0.13 mm	
IC	S	m													
Theoretical diameter of inscribed circle	Insert thickness														
E	±0.025 mm	±0.025 mm													
G	±0.025 mm	±0.13 mm													

5 - Theoretical diameter of inscribed circle	6 - Thickness	7 - Type of Insert	8 - RH/LH Insert	9 - Pitch
4 - 1/2" (12.7 mm) 5 - 5/8" (15.875 mm) 6 - 6/8" (19.05 mm)	3 - 3/16" (4.76 mm) 4 - 4/16" (6.35 mm) 5 - 5/16" (7.94 mm) 6 - 6/16" (9.525 mm)	E - External I - Internal EI - External + Internal	R - Right Hand Insert L - Left Hand Insert	10-5 TPI
10 - Standard		11 - No. of Teeth	12 - Carbide Grades	
ACME - ACME STACME - Stub ACME API - API BUT - API Buttress Casing APIRD - API Round Casing & Tubing		(For Multitooth Style) T3-T5	VKX, VKXP, VTX, VTXP	

■ VG-Cut Inserts

VG	D	3.0	UN	12	RH	-	RS	VPG
1	2	3	4	5	6		7	8

1 - Line Name	2 - Number of Cutting Corners	3 - Inserts Width	4 - Standard								
VG - Deep Grooving, Threading & Parting Off	D - Double	3.0 mm	60 - Partial Profile 60° 55 - Partial Profile 55° ISO - ISO Metric UN - American UN W - Whitworth for BSW, BSP NPT - NPT								
5 - Pitch	6 - RH/LH Inserts	7 - Top Rake Geometry	8 - Carbide Grade								
Full Profile - Pitch Range <table border="1"> <tr><th>mm</th><th>TPI</th></tr> <tr><td>0.5-2.0</td><td>32-11.5</td></tr> </table> Partial Profile - Pitch Range <table border="1"> <tr><th>mm</th><th>TPI</th></tr> <tr><td>A 0.5 - 1.5</td><td>48 -16</td></tr> </table>	mm	TPI	0.5-2.0	32-11.5	mm	TPI	A 0.5 - 1.5	48 -16	RH Helix LH Helix	RS - Close to right shoulder LS - Close to left shoulder	VPG
mm	TPI										
0.5-2.0	32-11.5										
mm	TPI										
A 0.5 - 1.5	48 -16										

■ Mini-V Inserts

V	08	TH	1.5	ISO	R	VBX
1	2	3	4	5	6	7

1 - Product Line	2 - Insert Style	3 - Type of Application	4 - Pitch (for Threading)	5 - Threading Standard																									
V - Mini-V	08, 11, 14, 16	TH - Threading	Full Profile - Pitch Range <table border="1"> <tr><th>mm</th><th>TPI</th></tr> <tr><td>0.5-2.0</td><td>32-12</td></tr> </table> Partial Profile - Pitch Range <table border="1"> <tr><th></th><th>mm</th><th>TPI</th></tr> <tr><td>A</td><td>0.5-1.50</td><td>48-16</td></tr> <tr><td>H</td><td>0.5-.75</td><td>48-32</td></tr> <tr><td>I</td><td>1.0-1.25</td><td>24-20</td></tr> <tr><td>J</td><td>1.5-1.75</td><td>16-14</td></tr> <tr><td>G</td><td>1.75-3.0</td><td>14-8</td></tr> <tr><td>AG</td><td>0.5-3.0</td><td>48-8</td></tr> </table>	mm	TPI	0.5-2.0	32-12		mm	TPI	A	0.5-1.50	48-16	H	0.5-.75	48-32	I	1.0-1.25	24-20	J	1.5-1.75	16-14	G	1.75-3.0	14-8	AG	0.5-3.0	48-8	60 - Partial Profile 60° 55 - Partial Profile 55° ISO - ISO Metric UN - American UN W - Whitworth for BSW, BSP BSPT - British Standard Pipe Thread NPT - NPT National Pipe Thread NPTF - NPTF National Seal Pipe Thread TR - Trapez Din 103
mm	TPI																												
0.5-2.0	32-12																												
	mm	TPI																											
A	0.5-1.50	48-16																											
H	0.5-.75	48-32																											
I	1.0-1.25	24-20																											
J	1.5-1.75	16-14																											
G	1.75-3.0	14-8																											
AG	0.5-3.0	48-8																											
6 - RH	7 - Carbide Grade																												
R - RH Helix	VBX																												

Partial Profile 60°

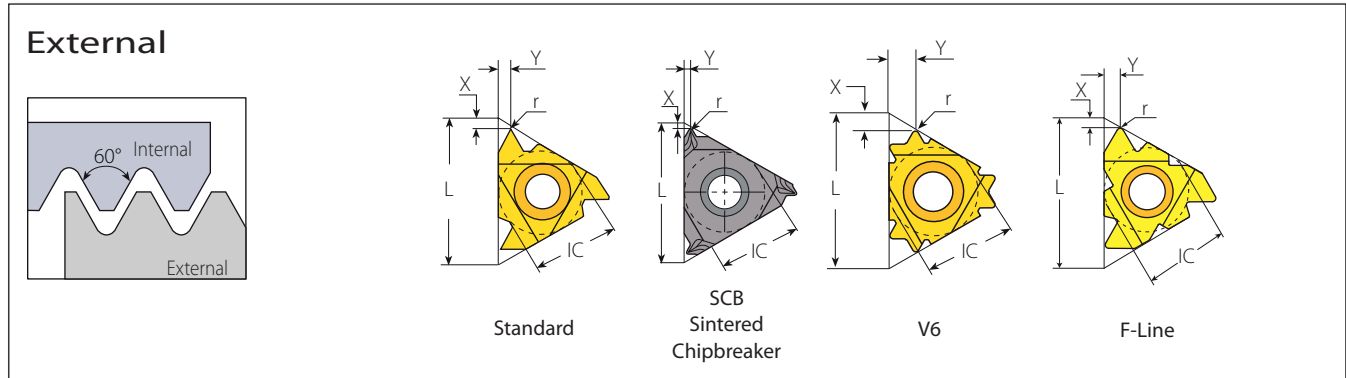

Standard



SCB



V6



F-Line

Insert Size	Pitch			Ordering Code		Dimensions inch			Anvil		Toolholder	
	IC	L inch	mm	TPI	RH	LH	r	X	Y	RH		LH
1/4"	.43	0.5-1.5	48-16	2ERA60...	2ELA60...		.002	.03	.04	-	-	NL..-2 (LH)
				3ERA60...	3ELA60...		.002	.03	.04			
3/8"	.63	1.75-3.0	14-8	3ERG60...	3ELG60...		.011	.05	.07	YE3	YI3	AL..-3 (LH)
		0.5-3.0	48-8	3ERAG60...	3ELAG60...		.003	.05	.07			
3/8"	.63	0.5-1.5	48-16	3JERA60...			.002	.02	.03			
		1.75-3.0	14-8	3JERG60...			.011	.04	.06	YE3	-	AL..-3
		0.5-3.0	48-8	3JERAG60...			.003	.04	.06			
3/8" V6	.63	0.5-2.0	48-13	3ERS60-6C...			.002	.07	.12	YE3-6C	-	AL..-3
1/2"	.87	3.5-5.0	7-5	4ERN60...	4ELN60...		.021	.07	.10	YE4	YI4	AL..-4 (LH)
1/2"F	.91	3.5-5.0	7-5	4FERN60...			.021	.07	.10	YE4F	-	AL..-4F
5/8"	1.06	5.5-6.0	4.5-4	5ERQ60...	5ELQ60...		.025	.08	.12	YE5	YI5	AL..-5 (LH)

Partial Profile 60° (con't)

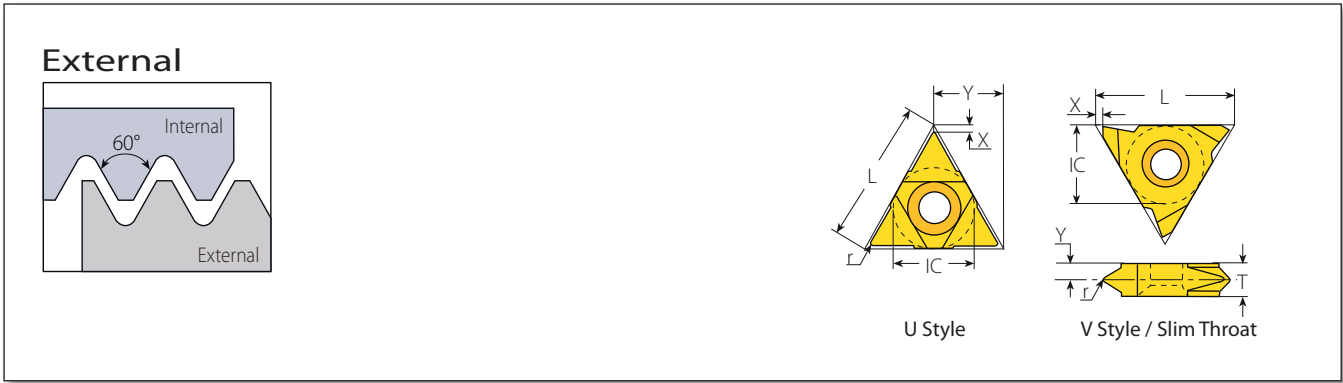

U Style



Insert Size		Pitch		Ordering Code		Dimensions inch			Anvil		
IC	L inch	mm	TPI	RH+LH		r	X	Y	RH	LH	Toolholder
1/2"U	.87	5.5-8.0	4.5-3.25	4UEIU60...		.012	.02	.43	YE4U	YI4U	AL...-4U (LH)
5/8"U	1.06	6.5-9.0	4-2.75	5UEIU60...		.015	.04	.54	YE5U	YI5U	AL...-5U (LH)

Slim Throat



Insert Size		Pitch		Ordering Code		Dimensions inch				
IC	L inch	mm	TPI	RH	LH	r	X	Y	T	Toolholder
1/4"V	.43	0.5-1.5	48-16	2VERA60...	2VELA60...	.002	.03	.09	.13	NL...-2V (LH)
		0.5-1.5	48-16	3VERA60...	3VELA60...	.002	.04	.11	.14	
3/8"V	.63	1.75-3.0	14-8	3VERG60...	3VELG60...	.011	.04	.07	.14	NL...-3V (LH)
		0.5-3.0	48-8	3VERAG60...	3VELAG60...	.003	.04	.07	.14	
1/2"V	.87	3.5-5.0	7-5	4VERN60...	4VELN60...	.021	.04	.09	.19	NL...-4V (LH)

V Style



Insert Size		Pitch		Ordering Code		Dimensions inch				
IC	L inch	mm	TPI	RH	LH	r	X	Y	T	Toolholder
5/8"V	1.06	6.0-10.0	4-2.5	5VERV60...	5VELV60...	.03	.02	.20	.39	NL...-5V-10 (LH)

Partial Profile 60°



VG-Cut



Pocket Size	Ordering Code	Pitch		Dimensions inch			No. of Passes	Helix	Min. Thread Diameter	Toolholder	
	RH	W ref	mm	TPI	R	Y	L ref	Deg		Monoblock	
3	VGD3.0A60RH...	.12	0.5-1.5	48-16	.002	.07	.86	5-8	1.5°	Partial Profile A60	VGE...T12

Partial Profile 60° (con't)

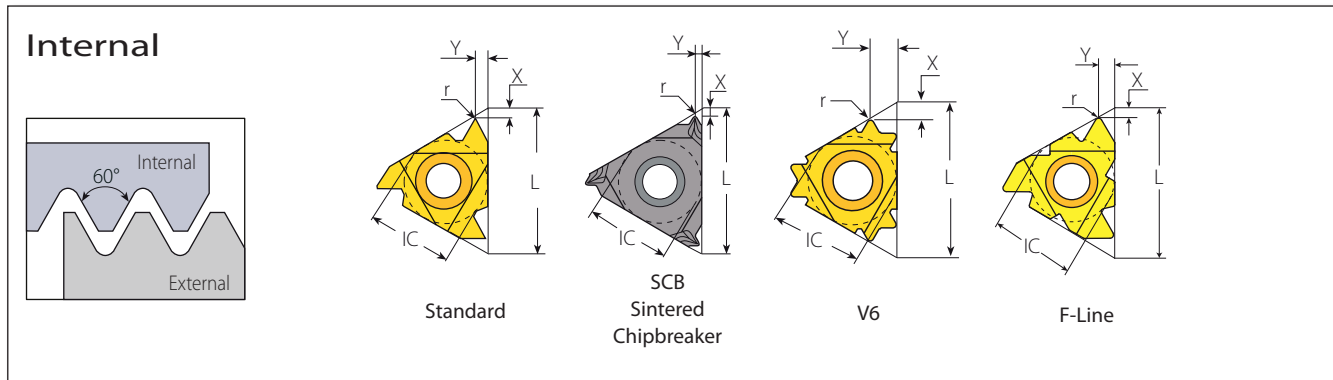

Standard



Insert Size	Pitch			Ordering Code		Dimensions inch			Anvil		Toolholder	
	IC	L inch	mm	TPI	RH	LH	r	X	Y	RH		LH
1/4"	.43	0.5-1.5	48-16		2IRA60...	2ILA60...	.002	.03	.04	-	-	NVR...-2 (LH)
1/4" SCB	.43	0.5-1.5	48-16		2JIRA60...		.002	.02	.03	-	-	NVR...-2
3/8"	.63	0.5-1.5	48-16		3IRA60...	3ILA60...	.002	.03	.04	-	-	AVR...-3 (LH)
		1.75-3.0	14-8		3IRG60...	3ILG60...	.006	.05	.07	Y13	YE3	
		0.5-3.0	48-8		3IRAG60...	3ILAG60...	.002	.05	.07			

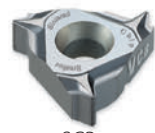

SCB



V6

3/8" SCB	.63	0.5-1.5	48-16		3JIRA60...		.002	.02	.03	-	-	AVR...-3
		1.75-3.0	14-8		3JIRG60...		.006	.04	.06	Y13		
		0.5-3.0	48-8		3JIRAG60...		.002	.04	.06			
3/8" V6	.63	0.5-2.0	48-14		3IRS60-6C...		.001	.06	.10	Y13-6C	-	AVR...-3 NVRC...-3V6



F-Line

1/2"	.87	3.5-5.0	7-5		4IRN60...	4ILN60...	.012	.07	.10	Y14	YE4	AVR...-4 (LH)
1/2"F	.91	3.5-5.0	7-5		4FIRN60...		.012	.07	.10	Y14F	-	AVRC...-4F
5/8"	1.06	5.5-6.0	4.5-4		5IRQ60...	5ILQ60...	.012	.07	.11	Y15	YE5	AVR...-5 (LH)

Partial Profile 60° (con't)

Internal

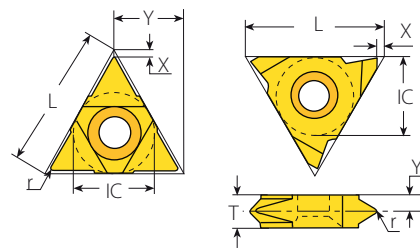
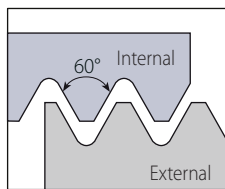

U Style

V Style

U Style



Insert Size		Pitch		Ordering Code	Dimensions inch			Anvil		
IC	L inch	mm	TPI	RH+LH	r	X	Y	RH	LH	Toolholder
1/2"U	.87	5.5-8.0	4.5-3.25	4UEIU60...	.012	.02	.43	YI4U	YE4U	AVR...-4U (LH)
5/8"U	1.06	6.5-9.0	4-2.75	5UEIU60...	.015	.04	.54	YI5U	YE5U	AVR...-5U (LH)

V Style



Insert Size		Pitch		Ordering Code		Dimensions inch				
IC	L inch	mm	TPI	RH	LH	r	X	Y	T	Toolholder
5/8"V	1.06	6.0-10.0	4-2.5	5VIRV60...	5VILV60...	.014	.04	.17	.31	NVR...-5V (LH)

Partial Profile 60° (con't)

Mini-V

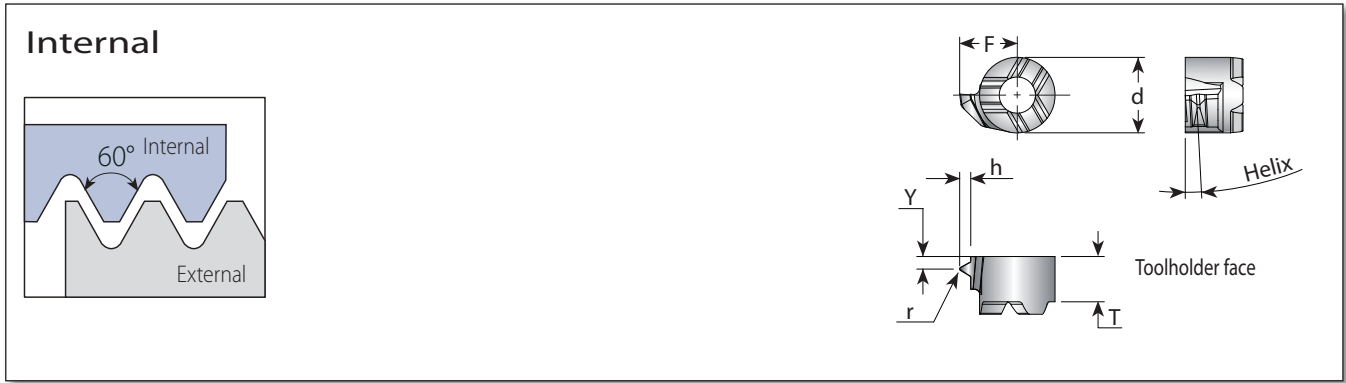

Mini-V



Insert Style	Pitch		Ordering Code	Dimensions inch						Helix Deg.	Toolholder
	TPI	mm		d	T	F	Y	r			
V08	48-32	0.5-0.75	V08THH60R...	.236	.15	.17	.02	.001	1.5	.V08-...	
	24-20	1.0-1.25	V08THI60R...			.18	.03	.004	2.5		
	16-14	1.5-1.75	V08THJ60R...			.19	.04	.006	3		
V11	48-32	0.5-0.75	V11THH60R...	.315	.17	.23	.02	.012	1.5	.V11-...	
	24-20	1.0-1.25	V11THI60R...			.24	.03	.004	1.5		
	16-14	1.5-1.75	V11THJ60R...			.22	.04	.006	3		
V14	48-16	0.5-1.5	V14THA60R...	.354	.22	.35	.04	.002	1.5	.V14-...	
	14-8	1.75-3.0	V14THG60R...			.07	.006				
	48-8	0.5-3.0	V14THAG60R...			.07	.002				
V16	48-16	0.5-1.5	V16THA60R...	.433	.22	.40	.04	.002	1.5	.V16-...	
	14-8	1.75-3.0	V16THG60R...			.07	.006				
	48-8	0.5-3.0	V16THAG60R...			.07	.002				

Partial Profile 60° (con't)

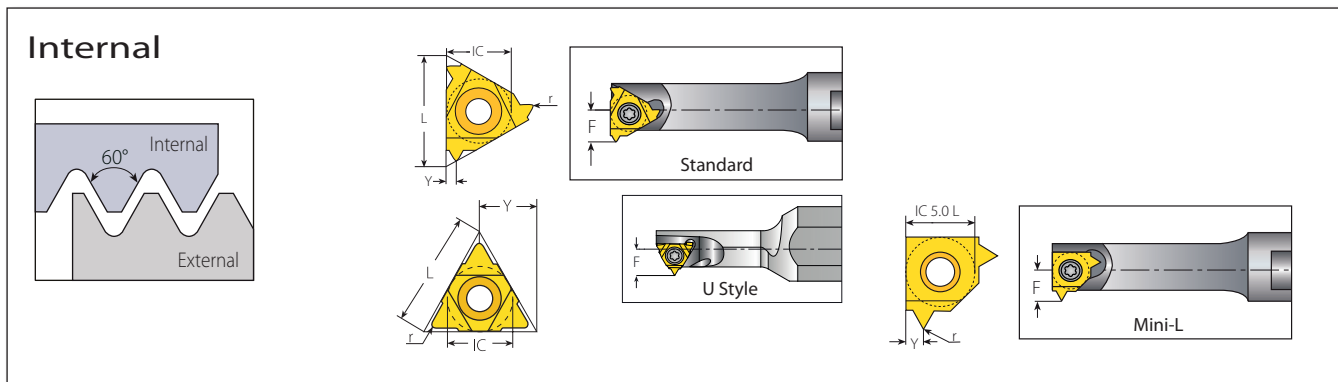

Mini-3 Standard



Insert Size		Pitch		Ordering Code		Dimensions inch			Min. Bore Dia.	Toolholder
IC mm	L inch	mm	TPI	RH	LH	r	Y	F	inch	
4.0	.24	0.5-1.25	48-20	4.0KIRA60...	4.0KILA60...	.002	.02	.15	.25	.NVR...-4.0K (LH)
5.0	.31	0.5-1.5	48-16	5.0KIRA60...	5.0KILA60...	.002	.03	.19	.31	.NVR...-5.0K (LH)
6.0	.39	0.5-1.5	48-16	6.0KIRA60...	6.0KILA60...	.002	.04	.21	.39	.NVR...-6.0K (LH)

Left handed tool supplied by request (Example: 6.0ILA60...).

Mini-3 U Style



Insert Size		Pitch		Ordering Code		Dimensions inch			Min. Bore Dia.	Toolholder
IC mm	L inch	mm	TPI	RH+LH		r	Y	F	inch	
5.0U	.31	1.75-2.0	14-11	5.0KUIB60...		.006	.16	.23	.35	.NVR...-5.0KU (LH)

Mini-L



Insert Size		Pitch		Ordering Code		Dimensions inch			Min. Bore Dia.	Toolholder
IC mm	mm	TPI	RH	LH	r	Y	F	inch		
5.0L	0.5-1.5	48-16	5LKIRA60...	5LKILA60...	.002	.04	.18	.31	.NVR...-5LK (LH)	

Partial Profile 60° (con't)

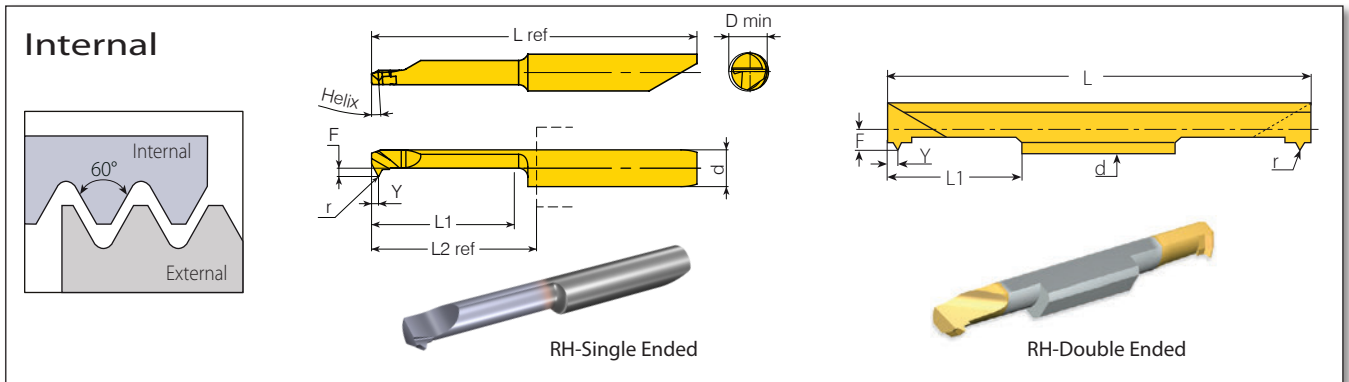
MINIPRO

Micro - Double Ended

Insert Dia.		Pitch		Ordering Code	Dimensions inch					Min. Bore Dia.	Toolholder
d mm	mm	TPI		RH	r	L1	L	F	Y	inch	
3.0	0.5-1.0	48-24		3.0SIRF60...	.002	.63	1.97	.06	.04	.13	SMC..-3.0
4.0	0.5-1.0	48-24		4.0SIRF60...	.002	.63	1.97	.08	.04	.17	SMC..-4.0
6.0	0.5-1.5	48-16		6.0SIRA60...	.002	.63	1.97	.10	.04	.24	SMC..-6.0

Left handed tool supplied by request (Example: 6.0SILA60...).

Micro - Single Ended

microscope

Insert Dia.		Pitch		Ordering Code	Dimensions inch							Min. Bore Dia.	Toolholder
d mm	mm	TPI		RH/LH	Helix °	r	L1	F	Y	L2 ref*	L ref	D inch	
4.0	0.5-1.0	48-24		MS429THF60L16R/L...	3.5	.001	.63	.04	.04	.72	1.39	.13	MH...-4.0
	0.5-1.0	48-24		MS439THF60L16R/L...		.001		.07				.17	
6.0	0.5-1.5	48-16		M659THA60L16R/L...		.002		.11		.73	1.66	.24	MH...-6.0

* L2 Ref: Repeatability within +/- .0008

Partial Profile 55°

External

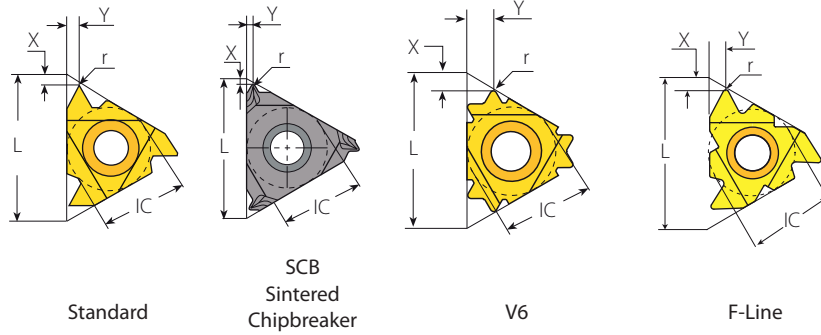
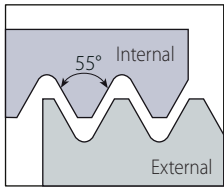

Standard



SCB



V6



F-LINE

Insert Size		Pitch		Ordering Code		Dimensions inch			Anvil		Toolholder
IC	L inch	mm	TPI	RH	LH	r	X	Y	RH	LH	
1/4"	.43	0.5-1.5	48-16	2ERA55...	2ELA55...	.002	.03	.04	-	-	NL..-2 (LH)
		0.5-1.5	48-16	3ERA55...	3ELA55...	.002	.03	.04			
3/8"	.63	1.75-3.0	14-8	3ERG55...	3ELG55...	.008	.05	.07	YE3	YI3	AL..-3 (LH)
		0.5-3.0	48-8	3ERAG55...	3ELAG55...	.003	.05	.07			
3/8"	.63	0.5-1.5	48-16	3JERA55...		.002	.02	.03	YE3	-	AL..-3
		1.75-3.0	14-8	3JERG55...		.008	.04	.06			
		0.5-3.0	48-8	3JERAG55...		.003	.04	.06			
3/8"	.63	0.5-1.75	48-14	3ERS55-6C...		.002	.07	.11	YE3-6C	-	AL..-3
1/2"	.87	3.5-5.0	7-5	4ERN55...	4ELN55...	.017	.07	.10	YE4	YI4	AL..-4 (LH)
1/2"	.91	3.5-5.0	7-5	4FERN55...		.017	.07	.10	YE4F	-	AL..-4F
5/8"	1.06	5.5-6.0	4.5-4	5ERQ55...	5ELQ55...	.024	.08	.11	YE5	YI5	AL..-5 (LH)

Partial Profile 55° (con't)

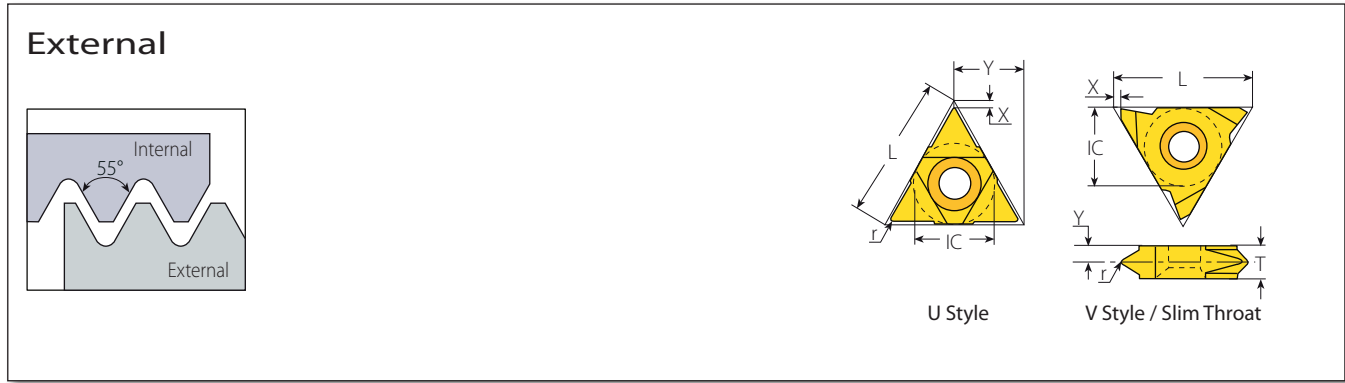

U Style



Insert Size		Pitch		Ordering Code		Dimensions inch			Anvil		
IC	L inch	mm	TPI	RH+LH		r	X	Y	RH	LH	Toolholder
1/2"U	.87	5.5-8.0	4.5-3.25	4UEIU55...		.024	.04	.43	YE4U	YI4U	AL..-4U (LH)
5/8"U	1.06	6.5-9.0	4-2.75	5UEIU55...		.031	.05	.54	YE5U	YI5U	AL..-5U (LH)

Slim Throat



Insert Size		Pitch		Ordering Code		Dimensions inch				
IC	L inch	mm	TPI	RH	LH	r	X	Y	T	Toolholder
1/4"V	.43	0.5-1.5	48-16	2VERA55...	2VELA55...	.002	.03	.11	.13	NL..-2V (LH)
		0.5-1.5	48-16	3VERA55...	3VELA55...	.002	.04	.11	.14	
3/8"V	.63	1.75-3.0	14-8	3VERG55...	3VELG55...	.008	.04	.07	.14	NL..-3V (LH)
		0.5-3.0	48-8	3VERAG55...	3VELAG55...	.003	.04	.07	.14	
1/2"V	.87	3.5-5.0	7-5	4VERN55...	4VELN55...	.017	.04	.09	.19	NL..-4V (LH)

V Style



Insert Size		Pitch		Ordering Code		Dimensions inch				
IC	L inch	mm	TPI	RH	LH	r	X	Y	T	Toolholder
5/8"V	1.06	6.0-9.0	4-2.75	5VERV55...	5VELV55...	.028	.04	.17	.31	NL..-5V-8 (LH)

Partial Profile 55°

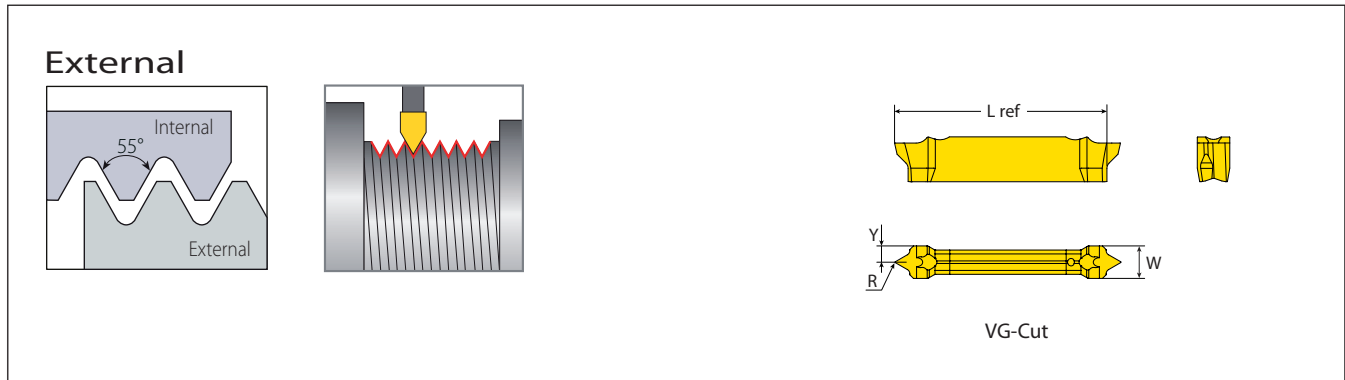

VG-Cut



Pocket Size	Ordering Code	Dimensions inch					No. of Passes	Helix	Min. Thread Diameter	Toolholder
	RH	W ref	Pitch TPI	R	Y	L ref	Deg		Monoblock	
3	VGD3.0A55RH...	.12	48-16	.002	.07	0.86	1.5°	Partial Profile A55	VGE...T12	

Partial Profile 55° (con't)

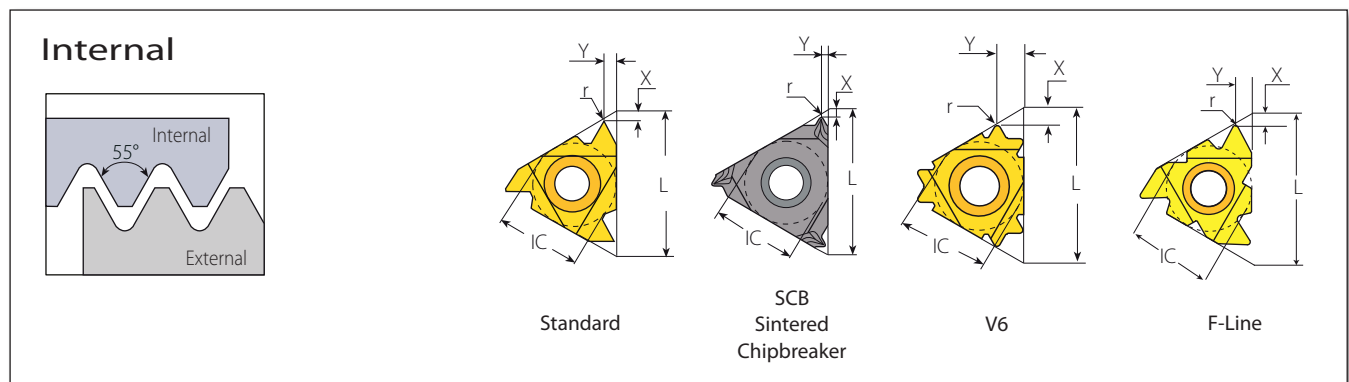

Standard



Insert Size		Pitch		Ordering Code		Dimensions inch			Anvil		Toolholder
IC	L inch	mm	TPI	RH	LH	r	X	Y	RH	LH	
1/4"	.43	0.5-1.5	48-16	2IRA55...	2ILA55...	.002	.03	.04	-	-	NVR...-2 (LH)
1/4" SCB	.43	0.5-1.5	48-16	2JIRA55...		.002	.02	.03	-	-	NVR...-2



3/8"	.63	0.5-1.5	48-16	3IRA55...	3ILA55...	.002	.03	.04	Y13	YE3	AVR...-3 (LH)
		1.75-3.0	14-8	3IRG55...	3ILG55...	.008	.05	.07			
		0.5-3.0	48-8	3IRAG55...	3ILAG55...	.003	.05	.07			



3/8" SCB	.63	0.5-1.5	48-16	3JIRA55...		.002	.02	.03	Y13	-	AVR...-3
		1.75-3.0	14-8	3JIRG55...		.008	.04	.06			
		0.5-3.0	48-8	3JIRAG55...		.003	.04	.06			
3/8" V6	.63	0.5-1.5	48-16	3IRS55-6C...		.002	.06	.10	Y13-6C	-	AVR...-3 NVRC...-3V6



1/2"	.87	3.5-5.0	7-5	4IRN55...	4ILN55...	.017	.07	.10	Y14	YE4	AVR...-4 (LH)
1/2" ^F	.91	3.5-5.0	7-5	4FIRN55...		.017	.07	.10	Y14 ^F	-	AVRC...-4 ^F
5/8"	1.06	5.5-6.0	4.5-4	5IRQ55...	5ILQ55...	.024	.08	.11	Y15	YE5	AVR...-5 (LH)

Partial Profile 55° (con't)

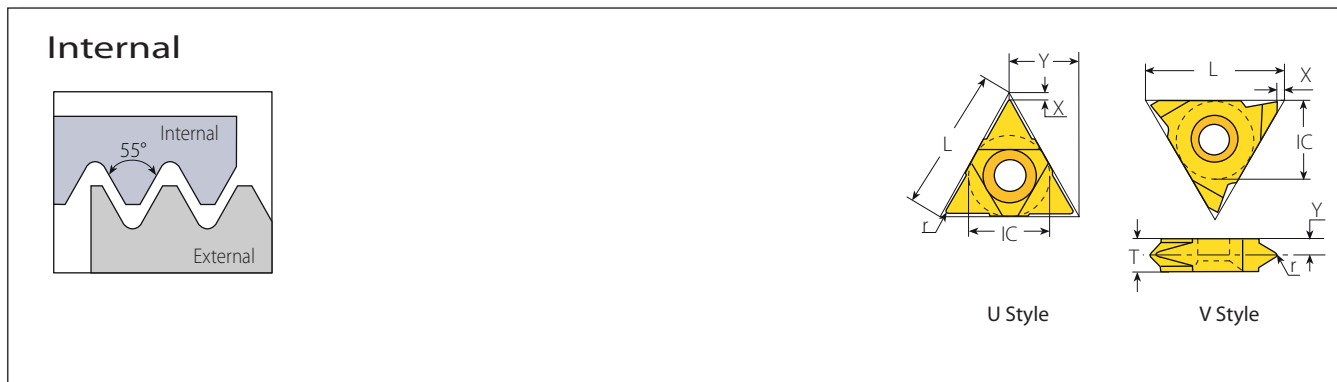

U Style



Insert Size		Pitch		Ordering Code	Dimensions inch			Anvil		
IC	L inch	mm	TPI	RH+LH	r	X	Y	RH	LH	Toolholder
1/2"U	.87	5.5-8.0	4.5-3.25	4UEIU55...	.024	.04	.43	Y14U	YE4U	AVR...-4U (LH)
5/8"U	1.06	6.5-9.0	4-2.75	5UEIU55...	.031	.05	.54	Y15U	YE5U	AVR...-5U (LH)

V Style



Insert Size		Pitch		Ordering Code		Dimensions inch				
IC	L inch	mm	TPI	RH	LH	r	X	Y	T	Toolholder
5/8"V	1.06	6.0-9.0	4-2.75	5VIRV55...	5VILV55...	.028	.04	.17	.31	NVR...-5V (LH)

Partial Profile 55° (con't)

Mini-V

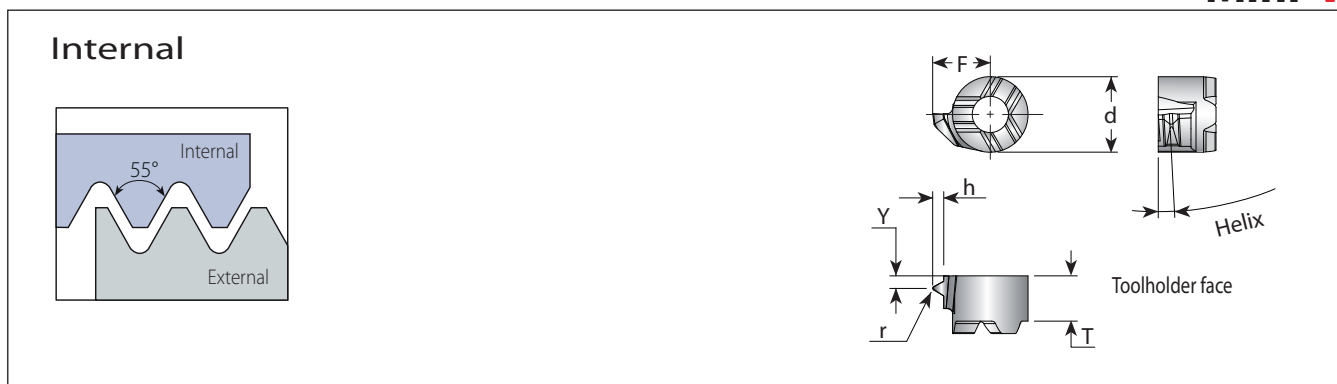

Mini-V



Insert Style	Pitch		Ordering Code	Dimensions inch					Helix	Toolholder
	TPI	mm	RH	d	T	F	Y	r	Deg.	
V14	48-16	0.5-1.5	V14THA55R...	.354	.22	.35	.04	.002	1.5	.V14-...
	14-8	1.75-3.0	V14THG55R...				.07	.008		
	48-8	0.5-3.0	V14THAG55R...				.07	.003		
V16	48-16	0.5-1.5	V16THA55R...	.433	.22	.40	.04	.003	1.5	.V16-...
	14-8	1.75-3.0	V16THG55R...				.07	.010		
	48-8	0.5-3.0	V16THAG55R...				.07	.003		

Partial Profile 55° (con't)

MINIPRO

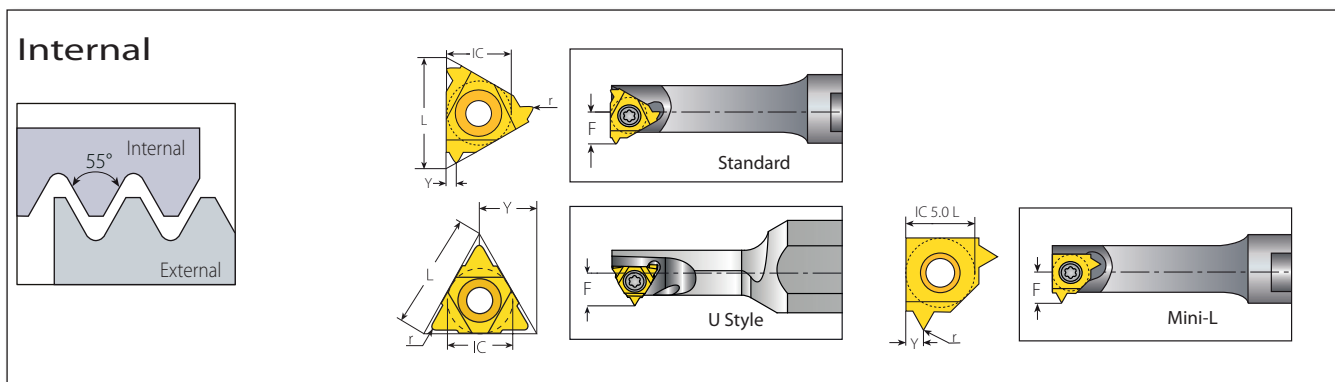

Mini-3 Standard



Insert Size		Pitch		Ordering Code		Dimensions inch			Min. Bore Dia.	Toolholder
IC mm	L inch	mm	TPI	RH	LH	r	Y	F	inch	
4.0	.24	0.5-1.25	48-20	4.0KIRA55...	4.0KILA55...	.002	.02	.15	.25	.NVR...-4.0K (LH)
5.0	.31	0.5-1.5	48-16	5.0KIRA55...	5.0KILA55...	.002	.03	.19	.31	.NVRC...-5.0K (LH)
6.0	.39	0.5-1.50	48-16	6.0KIRA55...	6.0KILA55...	.002	.04	.21	.39	.NVR...-6.0K (LH)

Mini-3 U Style



Insert Size		Pitch		Ordering Code	Dimensions inch			Min. Bore Dia.	Toolholder
IC mm	L inch	mm	TPI	RH+LH	r	Y	F	inch	
5.0U	.31	1.75-2.0	14-11	5.0KUIB55...	.008	.16	.22	.35	.NVR...-5.0KU (LH)

Mini-L



Insert Size		Pitch		Ordering Code		Dimensions inch			Min. Bore Dia.	Toolholder
IC mm	mm	TPI	RH	LH	r	Y	F	inch		
5.0L	0.5-1.5	48-16	5LKIRA55...	5LKILA55...	.002	.04	.18	.31	.NVR...-5LK (LH)	

Partial Profile 55° (con't)

MINIPRO

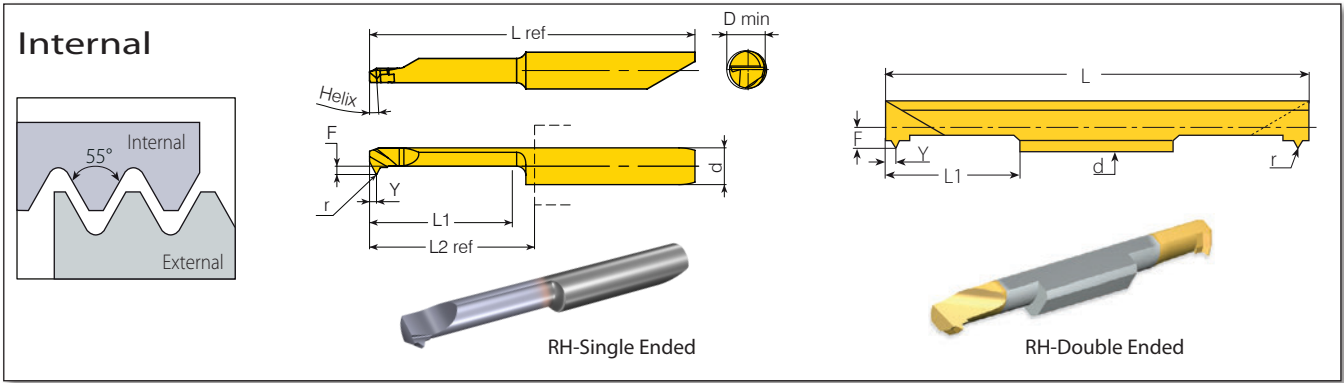

Micro - Double Ended

Insert Dia.	Pitch	Ordering Code		Dimensions inch						Min. Bore Dia.	
d mm	mm	TPI	RH	r	L1	L	F	Y	inch	Toolholder	
3.0	0.5-1.0	48-24	3.0SIRF55...	.002	.63	1.97	.06	.04	.13	SMC..-3.0	
4.0	0.5-1.0	48-24	4.0SIRF55...	.002	.63	1.97	.08	.04	.17	SMC..-4.0	
6.0	0.5-1.5	48-16	6.0SIRA55...	.002	.63	1.97	.10	.04	.24	SMC..-6.0	

Left handed tool supplied by request (Example: 6.0SILA55...).

Micro - Single Ended

microscope

Insert Dia.	Pitch		Ordering Code	Dimensions inch								Min. Bore Dia.	
d mm	mm	TPI	RH/LH	Helix°	r	L1	F	Y	L2 ref*	L ref	D inch	Toolholder	
4.0	0.5-1.0	48-24	MS429THF55L16R/L...	3.5	.002	.63	.04	.03	.72	1.39	.13	MH...-4.0	
	0.5-1.0	48-24	MS439THF55L16R/L...				.07				.17		
6.0	0.5-1.5	48-16	M659THA55L16R/L...		.002		.11	.04	.73	1.66	.24	MH...-6.0	

* L2 Ref: Repeatability within +/- .0008

ISO Metric

External

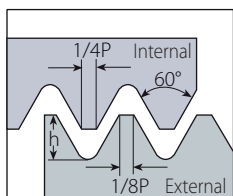

Defined by: R262 (DIN 13)
Tolerance class: 6g/6H

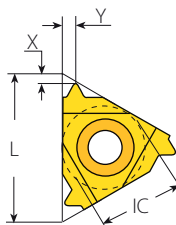

Standard

Standard

Insert Size		Pitch	Ordering Code		Dimensions inch			Anvil		Toolholder
IC	L inch	mm	RH	LH	h min	X	Y	RH	LH	
1/4"	.43	0.25	2ER0.25ISO...	2EL0.25ISO...	.006	.02	.01	-	-	NL..-2 (LH)
		0.3	2ER0.3ISO...	2EL0.3ISO...	.007	.03	.01			
		0.35	2ER0.35ISO...	2EL0.35ISO...	.008	.03	.02			
		0.4	2ER0.4ISO...	2EL0.4ISO...	.010	.03	.02			
		0.45	2ER0.45ISO...	2EL0.45ISO...	.011	.03	.02			
		0.5	2ER0.5ISO...	2EL0.5ISO...	.012	.02	.02			
		0.6	2ER0.6ISO...	2EL0.6ISO...	.015	.02	.02			
		0.7	2ER0.7ISO...	2EL0.7ISO...	.017	.02	.02			
		0.75	2ER0.75ISO...	2EL0.75ISO...	.018	.02	.02			
		0.8	2ER0.8ISO...	2EL0.8ISO...	.019	.02	.02			
		1.0	2ER1.0ISO...	2EL1.0ISO...	.024	.03	.03			
		1.25	2ER1.25ISO...	2EL1.25ISO...	.030	.03	.04			
		1.5	2ER1.5ISO...	2EL1.5ISO...	.036	.03	.04			
		1.75	2ER1.75ISO...	2EL1.75ISO...	.042	.03	.04			
3/8"	.63	0.25	3ER0.25ISO...	3EL0.25ISO...	.006	.02	.01	YE3	YI3	AL..-3 (LH)
		0.3	3ER0.3ISO...	3EL0.3ISO...	.007	.03	.01			
		0.35	3ER0.35ISO...	3EL0.35ISO...	.008	.03	.02			
		0.4	3ER0.4ISO...	3EL0.4ISO...	.010	.03	.02			
		0.45	3ER0.45ISO...	3EL0.45ISO...	.011	.03	.02			
		0.5	3ER0.5ISO...	3EL0.5ISO...	.012	.02	.02			
		0.6	3ER0.6ISO...	3EL0.6ISO...	.015	.02	.02			
		0.7	3ER0.7ISO...	3EL0.7ISO...	.017	.02	.02			
		0.75	3ER0.75ISO...	3EL0.75ISO...	.018	.02	.02			
		0.8	3ER0.8ISO...	3EL0.8ISO...	.019	.02	.02			
		1.0	3ER1.0ISO...	3EL1.0ISO...	.024	.03	.03			
		1.25	3ER1.25ISO...	3EL1.25ISO...	.030	.03	.04			
		1.5	3ER1.5ISO...	3EL1.5ISO...	.036	.03	.04			
		1.75	3ER1.75ISO...	3EL1.75ISO...	.042	.04	.05			
2.0	3ER2.0ISO...	3EL2.0ISO...	.048	.04	.05					
2.5	3ER2.5ISO...	3EL2.5ISO...	.060	.04	.06					
3.0	3ER3.0ISO...	3EL3.0ISO...	.072	.05	.06					
3.5	3ER3.5ISO...	3EL3.5ISO...	.085	.06	.07					



ISO Metric (con't)

External

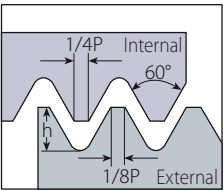

Defined by: R262 (DIN 13)
Tolerance class: 6g/6H

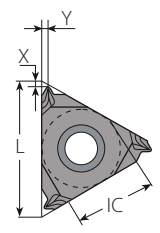

SCB
Sintered
Chipbreaker

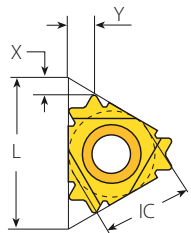

V6

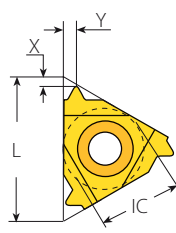

Standard

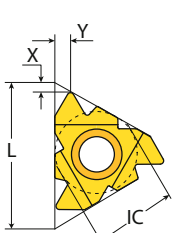

F-Line

Standard

	Insert Size		Pitch mm	Ordering Code		Dimensions inch			Anvil		Toolholder
	IC	L inch		RH	LH	h min	X	Y	RH	LH	
 SCB	3/8"	.63	0.5	3JER0.5ISO...		.012	.05	.02	YE3	-	AL...-3
			0.75	3JER0.75ISO...		.018	.05	.02			
			0.8	3JER0.8ISO...		.019	.05	.02			
			1.0	3JER1.0ISO...		.024	.03	.03			
			1.25	3JER1.25ISO...		.030	.03	.03			
			1.5	3JER1.5ISO...		.036	.03	.03			
			1.75	3JER1.75ISO...		.042	.05	.06			
			2.0	3JER2.0ISO...		.048	.05	.06			
			2.5	3JER2.5ISO...		.060	.05	.06			
			3.0	3JER3.0ISO...		.072	.05	.06			
 V6	3/8"	.63	0.5	3ER0.5ISO-6C...		.012	.09	.07	YE3-6C	-	AL...-3
			0.75	3ER0.75ISO-6C...		.018	.08	.07			
			0.8	3ER0.8ISO-6C...		.019	.08	.07			
			1.0	3ER1.0ISO-6C...		.024	.07	.08			
			1.25	3ER1.25ISO-6C...		.030	.07	.08			
			1.5	3ER1.5ISO-6C...		.036	.07	.09			
			1.75	3ER1.75ISO-6C...		.042	.07	.10			
			2.0	3ER2.0ISO-6C...		.048	.07	.11			
 4ER	1/2"	.87	3.5	4ER3.5ISO...	4EL3.5ISO...	.085	.06	.09	YE4	Y14	AL...-4 (LH)
			4.0	4ER4.0ISO...	4EL4.0ISO...	.096	.06	.09			
			4.5	4ER4.5ISO...	4EL4.5ISO...	.109	.07	.09			
			5.0	4ER5.0ISO...	4EL5.0ISO...	.121	.07	.10			
			5.5	4ER5.5ISO...	4EL5.5ISO...	.133	.07	.11			
			6.0	4ER6.0ISO...	4EL6.0ISO...	.145	.07	.11			
 4FER	1/2"	.91	3.5	4FER3.5ISO...		.085	.06	.09	YE4F	-	AL...-4F
			4.0	4FER4.0ISO...		.096	.06	.09			
			4.5	4FER4.5ISO...		.109	.07	.09			
			5.0	4FER5.0ISO...		.121	.07	.10			
			5.5	4FER5.5ISO...		.133	.07	.11			
			6.0	4FER6.0ISO...		.145	.07	.11			
 F-Line	5/8"	1.06	5.5	5ER5.5ISO...	5EL5.5ISO...	.133	.07	.11	YE5	Y15	AL...-5 (LH)
			6.0	5ER6.0ISO...	5EL6.0ISO...	.145	.08	.11			

ISO Metric (con't)

External

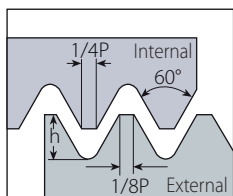

Defined by: R262 (DIN 13)
Tolerance class: 6g/6H

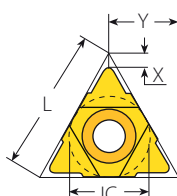

U Style

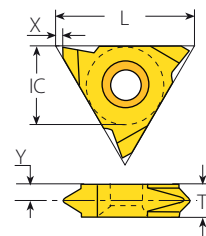

V Style / Slim Throat

U Style



IC	Insert Size		Pitch mm	Ordering Code		Dimensions inch			Anvil		Toolholder
	L inch	mm		RH+LH	h min	X	Y	RH	LH		
1/2"U	.87	5.0	4UE5.0ISO...	.121	.09	.43	YE4U	YI4U	AL...-4U (LH)		
		5.5	4UE5.5ISO...	.132	.09	.43					
		6.0	4UE6.0ISO...	.145	.10	.43					
5/8"U	1.06	8.0	5UE8.0ISO...	.193	.09	.54	YE5U	YI5U	AL...-5U (LH)		

Slim Throat



IC	Insert Size		Pitch mm	Ordering Code		Dimensions inch				Toolholder
	L inch	mm		RH	LH	h min	X	Y	T	
1/4"V	.43	0.75	2VER0.75ISO...	2VEL0.75ISO...	.018	.03	.10	.13	NL...-2V (LH)	
		1.0	2VER1.0ISO...	2VEL1.0ISO...	.024	.03	.10	.13		
		1.5	2VER1.5ISO...	2VEL1.5ISO...	.036	.03	.09	.13		
		1.75	2VER1.75ISO...	2VEL1.75ISO...	.042	.03	.08	.13		
		2.0	2VER2.0ISO...	2VEL2.0ISO...	.048	.03	.07	.13		
3/8"V	.63	0.35	3VER0.35ISO...	3VEL0.35ISO...	.008	.04	.13	.14	NL...-3V (LH)	
		0.4	3VER0.4ISO...	3VEL0.4ISO...	.010	.04	.13	.14		
		0.5	3VER0.5ISO...	3VEL0.5ISO...	.012	.04	.12	.14		
		0.75	3VER0.75ISO...	3VEL0.75ISO...	.018	.04	.12	.14		
		0.8	3VER0.8ISO...	3VEL0.8ISO...	.019	.04	.12	.14		
		1.0	3VER1.0ISO...	3VEL1.0ISO...	.024	.04	.11	.14		
		1.25	3VER1.25ISO...	3VEL1.25ISO...	.030	.04	.11	.14		
		1.5	3VER1.5ISO...	3VEL1.5ISO...	.036	.04	.10	.14		
		1.75	3VER1.75ISO...	3VEL1.75ISO...	.042	.04	.10	.14		
		2.0	3VER2.0ISO...	3VEL2.0ISO...	.048	.04	.09	.14		
		2.5	3VER2.5ISO...	3VEL2.5ISO...	.060	.04	.08	.14		
		3.0	3VER3.0ISO...	3VEL3.0ISO...	.072	.04	.08	.14		

V Style



IC	Insert Size		Pitch mm	Ordering Code		Dimensions inch			Toolholder
	L inch	mm		RH	LH	h min	X	Y	
5/8"V	1.06	5.5	5VER5.5ISO...	5VEL5.5ISO...	.133	.04	.13	.24	NL...-5V-6 (LH)
		6.0	5VER6.0ISO...	5VEL6.0ISO...	.145	.04	.13	.24	
		8.0	5VER8.0ISO...	5VEL8.0ISO...	.193	.04	.17	.31	
		10.0	5VER10.0ISO...	5VEL10.0ISO...	.241	.04	.20	.39	

ISO Metric (con't)

External

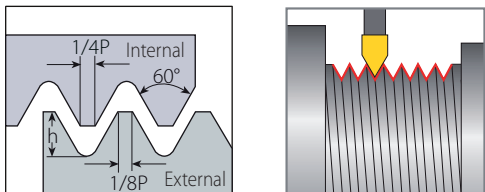

Defined by: R262 (DIN 13)
Tolerance class: 6g/6H

RS/LS

Varied range of threading standards for machining between shoulders and close to spindle.

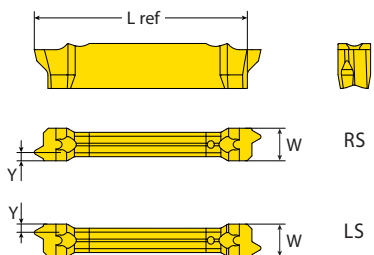

VG-Cut



Pocket Size	Ordering Code	Dimensions inch					No. of Passes	Helix	Min. Thread Diameter	Toolholder
		RH	W ref	Pitch mm	h min	Y				
3	VG D3.0 ISO 0.50 RH-RS/LS...		0.50	.012	.02		5 - 7		M 3x0.5	Monoblock
	VG D3.0 ISO 0.75 RH-RS/LS...		0.75	.018	.03		5 - 8		M 5x0.75	
	VG D3.0 ISO 1.00 RH-RS/LS...		1.00	.024	.03		5 - 9		M 6x1	
	VG D3.0 ISO 1.25 RH-RS/LS...	.12	1.25	.030	.03	.86	6 - 10	2.5°	M 8x1.25	VGE...T12
	VG D3.0 ISO 1.50 RH-RS/LS...		1.50	.036	.04		7 - 12		M10x1.5 Coarse	
	VG D3.0 ISO 1.75 RH-RS/LS...		1.75	.042	.05		8 - 14		M12x1.75 Coarse	
	VG D3.0 ISO 2.00 RH-RS/LS...		2.00	.048	.05		9 - 14		M16x2.0 Coarse	

LH Helix threads available upon request.

ISO Metric (con't)

MEGALINE

External

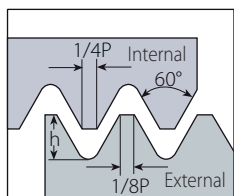

Defined by: R262 (DIN 13)
Tolerance class: 6g/6H

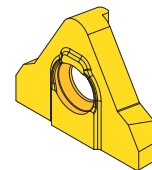
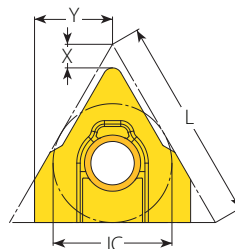

Mega Line

External

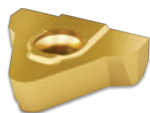

Insert Size		Pitch	Ordering Code	EDP No.	Dimensions inch			Number of Passes	
IC	L inch	mm	RH	VKX	h min	X	Y	0.003inch–Min. Depth of Cut (On radius)	0.006inch–Max. Depth of Cut (On radius)
5/8" MG	1.06	12.0	5MGER12.0ISO...	42495	.290	.16	.44	105	49
		16.0	5MGER16.0ISO...	42496	.387	.18		140	66
		18.0	5MGER18.0ISO...	42497	.435	.19		158	74
		20.0	5MGER20.0ISO...	42498	.483	.21		175	82
		25.0	5MGER25.0ISO...	42499	.604	.18		219	102

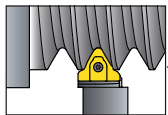

Recommended thread infeed method for Mega Line: Flank or Modified Flank 1°.

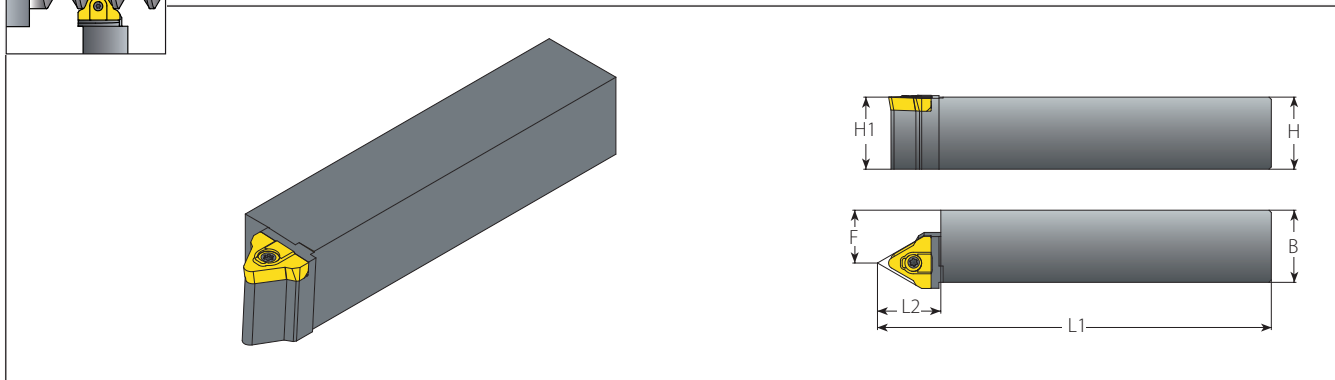

External Toolholders for ISO Metric

MEGA/LINE



External							Spare Parts		
Insert	Ordering Code	EDP No.	Dimensions inch			Thread Diameter Range (Min.)			
	RH		H=B=H1	F	L1	L2	Insert Screw	Torx Key	
5MGER12.0ISO...	NL100-5MG12ISO	66450	1.00	.65	6.1	.866	M43x12	S5MG	K6T
	NL125-5MG12ISO	66451	1.25	.93	6.9				
	NL150-5MG12ISO	66452	1.50	1.24	8.1				
5MGER16.0ISO...	NL100-5MG16ISO	66453	1.00	.65	6.1	.866	M57x16		
	NL125-5MG16ISO	66454	1.25	.93	6.9				
	NL150-5MG16ISO	66455	1.50	1.24	8.1				
5MGER18.0ISO...	NL100-5MG18ISO	66456	1.00	.65	6.1	.866	M65x18		
	NL125-5MG18ISO	66457	1.25	.93	6.9				
	NL150-5MG18ISO	66458	1.50	1.24	8.1				
5MGER20.0ISO...	NL100-5MG20ISO	66459	1.00	.65	6.1	.866	M72x20		
	NL125-5MG20ISO	66460	1.25	.93	6.9				
	NL150-5MG20ISO	66461	1.50	1.24	8.1				
5MGER25.0ISO...	NL100-5MG25ISO	66462	1.00	.65	6.1	.866	M90x25		
	NL125-5MG25ISO	66463	1.25	.93	6.9				
	NL150-5MG25ISO	66464	1.50	1.24	8.1				

Recommended thread infeed method for Mega Line: Flank or Modified Flank 1°.

ISO Metric (con't)

External

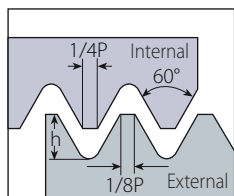

Defined by: R262 (DIN 13)
Tolerance class: 6g/6H

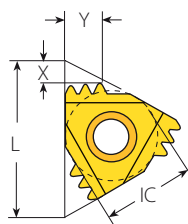

M+ Style

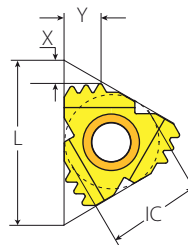

F-Line M+

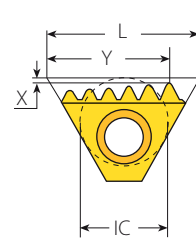

T+ Style

M+ Style



FLINE

Insert Size		Pitch	Teeth	Ordering Code	Dimensions inch			Anvil	Toolholder
IC	L inch	mm		RH	h min	X	Y	RH	
3/8"	.63	1.0	3	3ER1.0ISO3M+...	.024	.07	.10	YE3M	AL...-3
		1.5	2	3ER1.5ISO2M+...	.036	.06	.09		
		2.0	2	3ER2.0ISO2M+...	.048	.08	.12		
1/2"	.87	1.5	3	4ER1.5ISO3M+...	.036	.10	.15	YE4M	AL...-4
		2.0	2	4ER2.0ISO2M+...	.048	.08	.12		
		2.0	3	4ER2.0ISO3M+...	.048	.13	.20		
		2.5	2	4ER2.5ISO2M+...	.060	.10	.15		
1/2"F	.91	2.0	2	4FER2.0ISO2M+...	.048	.08	.12	YE4M2F	AL...-4MF
		2.0	3	4FER2.0ISO3M+...	.048	.13	.20	YE4M3F	
5/8"	1.06	3.0	2	5ER3.0ISO2M+...	.072	.12	.19	YE5M	AL...-5M

T+ Style



Insert Size		Pitch	Teeth	Ordering Code	Dimensions inch			Anvil	Toolholder
IC	L inch	mm		RH	h min	X	Y	RH	
1/2"T	.87	1.5	8	4ER1.5ISO8T+...	.036	.01	.49	Y4T	AL...-4T
		2.0	8	4ER2.0ISO8T+...	.048	.01	.69		

ISO Metric (con't)

Internal

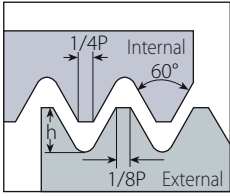

Defined by: R262 (DIN 13)
Tolerance class: 6g/6H

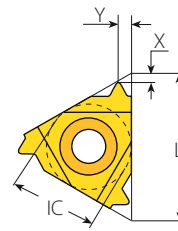

Standard

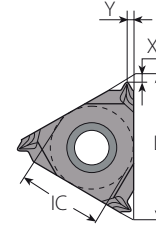

SCB
Sintered
Chipbreaker

Standard



Insert Size		Pitch	Ordering Code		Dimensions inch			Anvil		Toolholder
IC	L inch	mm	RH	LH	h min	X	Y	RH	LH	
1/4"	.43	0.35	2IR0.35ISO...	2IL0.35ISO...	.008	.03	.01	-	-	NVR..-2 (LH)
		0.4	2IR0.4ISO...	2IL0.4ISO...	.009	.03	.02			
		0.45	2IR0.45ISO...	2IL0.45ISO...	.010	.03	.02			
		0.5	2IR0.5ISO...	2IL0.5ISO...	.011	.02	.02			
		0.6	2IR0.6ISO...	2IL0.6ISO...	.014	.02	.02			
		0.7	2IR0.7ISO...	2IL0.7ISO...	.016	.02	.02			
		0.75	2IR0.75ISO...	2IL0.75ISO...	.017	.02	.02			
		0.8	2IR0.8ISO...	2IL0.8ISO...	.018	.02	.02			
		1.0	2IR1.0ISO...	2IL1.0ISO...	.023	.02	.03			
		1.25	2IR1.25ISO...	2IL1.25ISO...	.028	.03	.04			
		1.5	2IR1.5ISO...	2IL1.5ISO...	.034	.03	.04			
		1.75	2IR1.75ISO...	2IL1.75ISO...	.040	.04	.04			
		2.0	2IR2.0ISO...	2IL2.0ISO...	.045	.04	.04			
1/4" SCB	.43	0.5	2JIR0.5ISO...		.011	.05	.02	-	-	NVR..-2
		0.75	2JIR0.75ISO...		.017	.05	.02			
		0.8	2JIR0.8ISO...		.018	.05	.02			
		1.0	2JIR1.0ISO...		.023	.03	.03			
		1.25	2JIR1.25ISO...		.028	.03	.03			
3/8"	.63	0.35	3IR0.35ISO...	3IL0.35ISO...	.008	.03	.01	Y13	YE3	AVR..-3 (LH)
		0.4	3IR0.4ISO...	3IL0.4ISO...	.009	.03	.02			
		0.45	3IR0.45ISO...	3IL0.45ISO...	.010	.03	.02			
		0.5	3IR0.5ISO...	3IL0.5ISO...	.011	.02	.02			
		0.6	3IR0.6ISO...	3IL0.6ISO...	.014	.02	.02			
		0.7	3IR0.7ISO...	3IL0.7ISO...	.016	.02	.02			
		0.75	3IR0.75ISO...	3IL0.75ISO...	.017	.02	.02			
		0.8	3IR0.8ISO...	3IL0.8ISO...	.018	.02	.02			
		1.0	3IR1.0ISO...	3IL1.0ISO...	.023	.02	.03			
		1.25	3IR1.25ISO...	3IL1.25ISO...	.028	.03	.04			
		1.5	3IR1.5ISO...	3IL1.5ISO...	.034	.03	.04			
		1.75	3IR1.75ISO...	3IL1.75ISO...	.040	.04	.05			
		2.0	3IR2.0ISO...	3IL2.0ISO...	.045	.04	.05			
		2.5	3IR2.5ISO...	3IL2.5ISO...	.057	.04	.06			
		3.0	3IR3.0ISO...	3IL3.0ISO...	.068	.04	.06			
3.5	3IR3.5ISO...	3IL3.5ISO...	.080	.05	.06					

ISO Metric (con't)

Internal

Defined by: R262 (DIN 13)
Tolerance class: 6g/6H

SCB
Sintered
Chipbreaker

V6

Standard

F-Line

Standard

Insert Size		Pitch	Ordering Code		Dimensions inch			Anvil		Toolholder	
IC	L inch	mm	RH	LH	h min	X	Y	RH	LH		
	3/8" SCB	.63	1.0	3JIR1.0ISO...		.023	.03	.03	Y13	-	AVR...-3
			1.25	3JIR1.25ISO...		.028	.03	.03			
			1.5	3JIR1.5ISO...		.034	.03	.03			
			1.75	3JIR1.75ISO...		.040	.04	.06			
			2.0	3JIR2.0ISO...		.045	.04	.06			
			2.5	3JIR2.5ISO...		.057	.04	.06			
			3.0	3JIR3.0ISO...		.068	.04	.06			
	3/8" V6	.63	0.5	3IR0.5ISO-6C...		.011	.08	.07	Y13-6C	-	AVR...-3 NVRC...-3V6
			0.75	3IR0.75ISO-6C...		.017	.08	.07			
			0.8	3IR0.8ISO-6C...		.018	.07	.07			
			1.0	3IR1.0ISO-6C...		.023	.08	.08			
			1.25	3IR1.25ISO-6C...		.028	.07	.09			
			1.5	3IR1.5ISO-6C...		.034	.06	.09			
			1.75	3IR1.75ISO-6C...		.040	.06	.09			
	1/2"	.87	3.5	4IR3.5ISO...	4IL3.5ISO...	.080	.06	.09	Y14	YE4	AVR...-4 (LH)
			4.0	4IR4.0ISO...	4IL4.0ISO...	.091	.06	.09			
			4.5	4IR4.5ISO...	4IL4.5ISO...	.102	.06	.09			
			5.0	4IR5.0ISO...	4IL5.0ISO...	.114	.06	.09			
			5.5	4IR5.5ISO...	4IL5.5ISO...	.125	.06	.09			
			6.0	4IR6.0ISO...	4IL6.0ISO...	.136	.07	.10			
	1/2"F	.91	3.5	4FIR3.5ISO...		.080	.06	.09	Y14F		AVRC...-4F
			4	4FIR4.0ISO...		.091	.06	.09			
			4.5	4FIR4.5ISO...		.102	.06	.09			
			5	4FIR5.0ISO...		.114	.06	.09			
			5.5	4FIR5.5ISO...		.125	.06	.09			
			6	4FIR6.0ISO...		.136	.07	.10			
	5/8"	1.06	4.5	5IR4.5ISO...	5IL4.5ISO...	.102	.06	.09	Y15	YE5	AVR...-5 (LH)
			5.0	5IR5.0ISO...	5IL5.0ISO...	.114	.06	.09			
			5.5	5IR5.5ISO...	5IL5.5ISO...	.125	.06	.09			
			6.0	5IR6.0ISO...	5IL6.0ISO...	.136	.07	.10			

ISO Metric (con't)

Internal

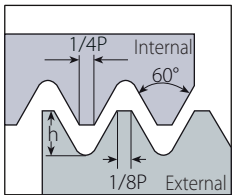

Defined by: R262 (DIN 13)
Tolerance class: 6g/6H

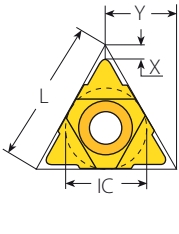

U Style

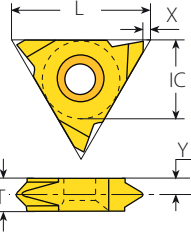

V Style

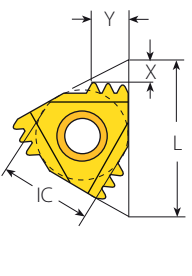

M+ Style

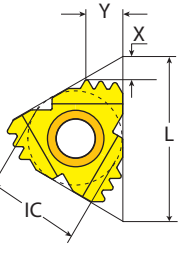

F-Line M+

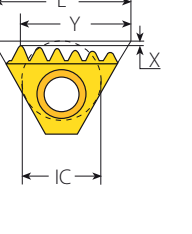

T+ Style

U Style



Insert Size		Pitch	Ordering Code		Dimensions inch			Anvil		Toolholder
IC	L inch	mm	RH+LH	h min	X	Y	RH	LH		
1/2"U	.87	5.5	4UI5.5ISO...	.125	.09	.43	Y14U	YE4U	AVR...-4U (LH)	
		6.0	4UI6.0ISO...	.136	.08	.43				
5/8"U	1.06	8.0	5UI8.0ISO...	.182	.09	.54	Y15U	YE5U	AVR...-5U (LH)	

V Style



Insert Size		Pitch	Ordering Code		Dimensions inch					Toolholder
IC	L inch	mm	RH	LH	h min	X	Y	T		
5/8"V	1.06	6.0	5VIR6.0ISO...	5VIL6.0ISO...	.136	.04	.13	.24	NVR...-5V (LH)	
		8.0	5VIR8.0ISO...	5VIL8.0ISO...	.182	.04	.17	.31		
		10.0	5VIR10.0ISO...	5VIL10.0ISO...	.227	.04	.20	.39		

M+ Style

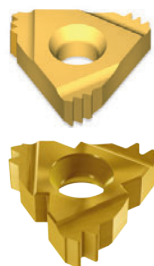

FLINE

Insert Size		Pitch	Teeth	Ordering Code		Dimensions inch			Anvil	Toolholder
IC	L inch	mm		RH	h min	X	Y	RH		
3/8"	.63	1.0	3	3IR1.0ISO3M+...	.023	.07	.10	Y13M	AVR...-3	
		1.5	2	3IR1.5ISO2M+...	.034	.06	.09			
		2.0	2	3IR2.0ISO2M+...	.045	.08	.12			
1/2"	.87	1.5	3	4IR1.5ISO3M+...	.034	.10	.15	Y14M	AVR...-4	
		2.0	2	4IR2.0ISO2M+...	.045	.08	.12			
1/2"F	.91	2.0	2	4FIR2.0ISO2M+...	.045	.08	.12	Y14M2F	AVRC...-4MF	
5/8"	1.06	3.0	2	5IR3.0ISO2M+...	.068	.12	.19	Y15M	AVR...-5M	

T+ Style



Insert Size		Pitch	Teeth	Ordering Code		Dimensions inch			Anvil	Toolholder
IC	L inch	mm		RH	h min	X	Y	RH		
1/2"	.87	1.5	8	4IR1.5ISO8T+...	.034	.01	.49	Y4T	AVR...-4T	
		2.0	8	4IR2.0ISO8T+...	.045	.01	.69			

ISO Metric (con't)

MEGALINE

Internal

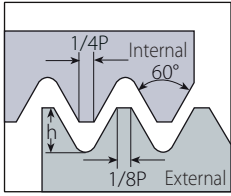

Defined by: R262 (DIN 13)
Tolerance class: 6g/6H

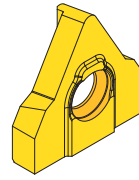

Mega Line

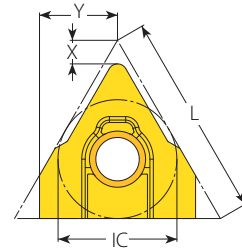

Internal



Insert Size		Pitch	Ordering Code	EDP No.	Dimensions inch			Number of Passes	
IC	L inch	mm	RH	VKX	h min	X	Y	0.003inch–Min. Depth of Cut (On radius)	0.006inch–Max. Depth of Cut (On radius)
5/8" MG	1.06	12.0	5MGIR12.0ISO...	42490	.273	.10	.41	99	46
		16.0	5MGIR16.0ISO...	42491	.367	.12		132	62
		18.0	5MGIR18.0ISO...	42492	.413	.12		149	69
		20.0	5MGIR20.0ISO...	42493	.458	.13		165	77
		25.0	5MGIR25.0ISO...	42494	.574	.14		206	96

Recommended thread infeed method for Mega Line: Flank or Modified Flank 1° .

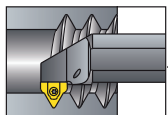

Internal Toolholders for ISO Metric

MEGA/LINE

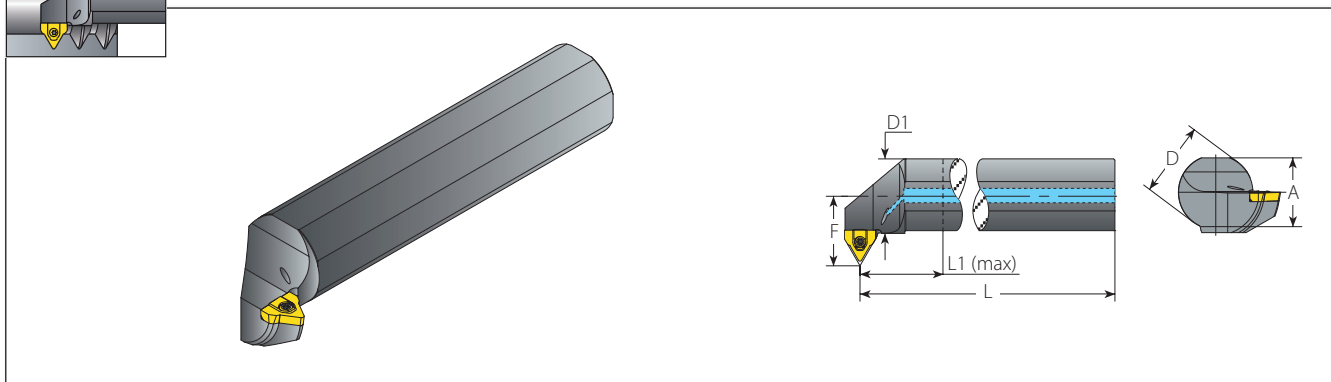

Internal

Spare Parts

Insert	Ordering Code	EDP No.	Dimensions inch						Min. Bore Dia.	Thread Diameter Range (Min.-Max.)		Spare Parts	
			A	L	L1 (max)	D	D1	F		inch	Short Chip Material	Long Chip Material	Insert Screw
5MGIR12.0ISO...	NVRC150-5MG12ISO	66465	1.42	9.15	4	1.5	1.49	1.63	2.36	(M73-90)x12	(M85-90)x12	S5MG	K6T
	NVRC200-5MG12ISO	66466	1.81	10.15	5	2.0	1.99	1.83	2.75	(M83-90)x12	(M83-90)x12		
5MGIR16.0ISO...	NVRC150-5MG16ISO	66467	1.42	9.15	4	1.5	1.49	1.63	2.34	(M77-190)x16	(M89-190)x16		
	NVRC200-5MG16ISO	66468	1.81	10.15	5	2.0	1.99	1.83	2.74	(M87-190)x16	(M101-190)x16		
5MGIR18.0ISO...	NVRC250-5MG16ISO	66469	2.28	11.10	6	2.5	2.49	2.03	3.29	(M97-190)x16	(M113-190)x16		
	NVRC150-5MG18ISO	66470	1.42	9.15	4	1.5	1.49	1.63	2.58	(M85-230)x18	(M91-230)x18		
	NVRC200-5MG18ISO	66471	1.81	10.15	5	2.0	1.99	1.83	2.74	(M89-230)x18	(M103-230)x18		
5MGIR20.0ISO...	NVRC250-5MG18ISO	66472	2.28	11.10	6	2.5	2.49	2.03	3.29	(M99-230)x18	(M115-230)x18		
	NVRC150-5MG20ISO	66473	1.42	9.15	4	1.5	1.49	1.63	2.77	(M92-290)x20	(M93-290)x20		
	NVRC200-5MG20ISO	66474	1.81	10.15	5	2.0	1.99	1.83	2.77	(M92-290)x20	(M105-290)x20		
5MGIR25.0ISO...	NVRC250-5MG20ISO	66475	2.28	11.10	6	2.5	2.49	2.03	3.24	(M101-290)x20	(M117-290)x20		
	NVRC150-5MG25ISO	66476	1.42	9.15	4	1.5	1.49	1.63	3.23	(M109-405)x25	(M109-405)x25		
	NVRC200-5MG25ISO	66477	1.81	10.15	5	2.0	1.99	1.83	3.23	(M109-405)x25	(M110-405)x25		
	NVRC250-5MG25ISO	66478	2.28	11.10	6	2.5	2.49	2.03	3.27	(M110-405)x25	(M127-405)x25		

Recommended thread infeed method for Mega Line: Flank or Modified Flank 1°.

ISO Metric (con't)

Mini-V

Internal

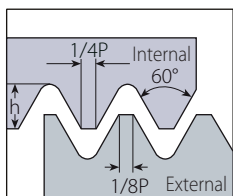

Defined by: R262 (DIN 13)
Tolerance class: 6g/6H

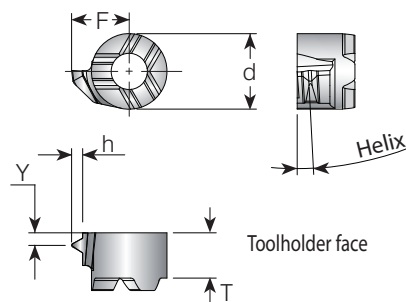

Mini-V



Min. Thread	Insert Style	Pitch	Ordering Code	Dimensions inch						Helix	Toolholder
				d	T	F	Y	h min	Deg.		
M8x0.5	V08	0.5	V08TH0.50ISOR...	.24	.15	.15	.01	.29	1	.V08-...	
M8.5x0.75		0.75	V08TH0.75ISOR...			.16	.02	.43	1.5		
M9x1.0		1.0	V08TH1.0ISOR...			.17	.02	.58	2		
M10x1.25		1.25	V08TH1.25ISOR...			.17	.03	.72	2.5		
M10x1.5		1.5	V08TH1.5ISOR...			.18	.04	.87	3		
M12x1.75		1.75	V08TH1.75ISOR...			.19	.04	1.01	3		
M14x2.0	V11	2.0	V11TH2.0ISOR...	.31	.17	.25	.04	1.15	2.5	.V11-...	

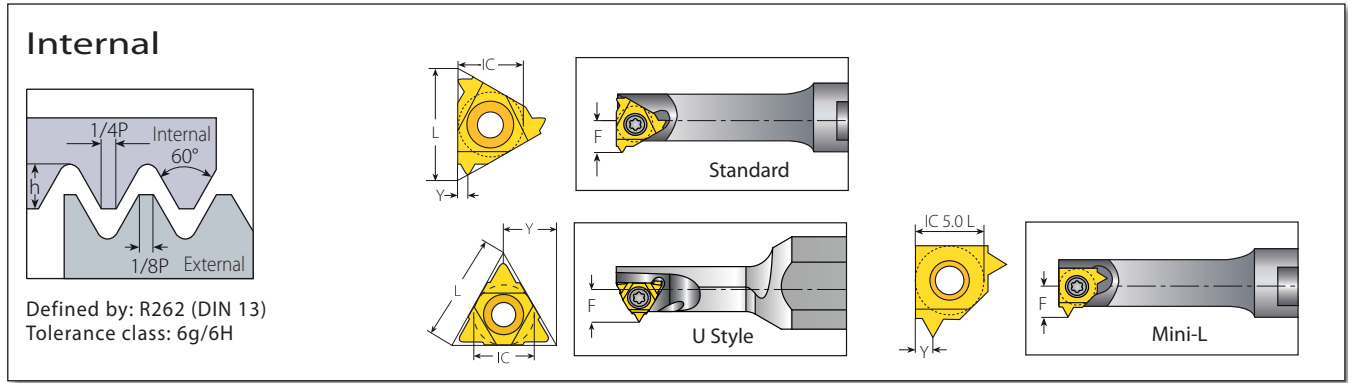

Mini-3 Standard



Insert Size		Pitch	Ordering Code		Dimensions inch			Min. Bore Dia.	Toolholder
IC mm	L inch	mm	RH	LH	h min	Y	F	inch	
4.0	.24	0.25	4.0KIR0.25ISO...	4.0KIL0.25ISO...	.006	.01	.13	.23	.NVR...-4.0K (LH)
		0.5	4.0KIR0.5ISO...	4.0KIL0.5ISO...	.011	.02	.13	.24	
		0.75	4.0KIR0.75ISO...	4.0KIL0.75ISO...	.017	.02	.14	.24	
		1.0	4.0KIR1.0ISO...	4.0KIL1.0ISO...	.023	.03	.14	.25	
		1.25	4.0KIR1.25ISO...	4.0KIL1.25ISO...	.028	.02	.15	.25	
5.0	.31	0.5	5.0KIR0.5ISO...	5.0KIL0.5ISO...	.011	.02			.NVR...-5.0K (LH)
		0.75	5.0KIR0.75ISO...	5.0KIL0.75ISO...	.017	.02			
		1.0	5.0KIR1.0ISO...	5.0KIL1.0ISO...	.023	.02			
		1.25	5.0KIR1.25ISO...	5.0KIL1.25ISO...	.028	.03	.19	.31	
		1.5	5.0KIR1.5ISO...	5.0KIL1.5ISO...	.034	.03			
6.0	.39	0.5	6.0KIR0.5ISO...	6.0KIL0.5ISO...	.011	.02	.17	.37	.NVR...-6.0K (LH)
		0.75	6.0KIR0.75ISO...	6.0KIL0.75ISO...	.017	.02	.18	.37	
		1.0	6.0KIR1.0ISO...	6.0KIL1.0ISO...	.023	.03	.19	.38	
		1.25	6.0KIR1.25ISO...	6.0KIL1.25ISO...	.028	.04	.19	.39	
		1.5	6.0KIR1.5ISO...	6.0KIL1.5ISO...	.034	.04	.20	.39	
		1.75	6.0KIR1.75ISO...	6.0KIL1.75ISO...	.040	.04	.20	.39	
		2.0	6.0KIR2.0ISO...	6.0KIL2.0ISO...	.045	.04	.21	.39	

Mini-3 U Style



Insert Size		Pitch	Ordering Code		Dimensions inch			Min. Bore Dia.	Toolholder
IC mm	L inch	mm	RH+LH		h min	Y	F	inch	
5.0U	.31	2.0	5.0KUI2.0ISO...		.048	.16	.22	.35	.NVR...-5.0KU (LH)

Mini-L



Insert Size		Pitch	Ordering Code		Dimensions inch			Min. Bore Dia.	Toolholder
IC mm	mm	mm	RH	LH	h min	Y	F	inch	
5.0L	0.35	5LKIR0.35ISO...	5LKIL0.35ISO...	.008	.01	.15	.29	.NVR...-5LK (LH)	
	0.5	5LKIR0.5ISO...	5LKIL0.5ISO...	.011	.02	.15	.29		
	0.75	5LKIR0.75ISO...	5LKIL0.75ISO...	.017	.02	.15	.30		
	1.0	5LKIR1.0ISO...	5LKIL1.0ISO...	.023	.03	.16	.30		
	1.25	5LKIR1.25ISO...	5LKIL1.25ISO...	.028	.04	.17	.31		
	1.5	5LKIR1.5ISO...	5LKIL1.5ISO...	.034	.04	.17	.31		
	1.75	5LKIR1.75ISO...	5LKIL1.75ISO...	.040	.04	.18	.31		
	2.0	5LKIR2.0ISO...	5LKIL2.0ISO...	.045	.04	.18	.31		

ISO Metric (con't)

MINIPRO

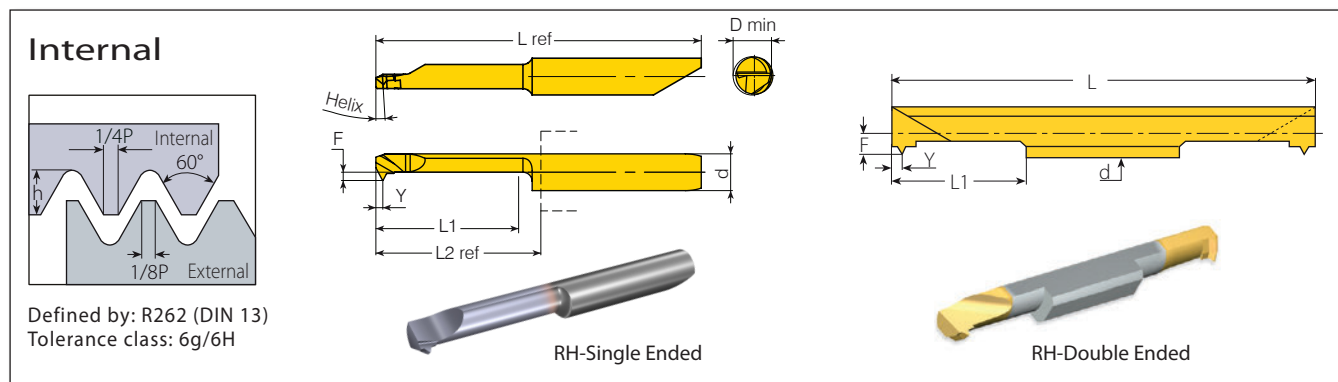

Micro - Double Ended

Thread	Insert Dia.	Pitch	Ordering Code		Dimensions inch					Min. Bore Dia.	Toolholder
	d mm		mm	RH	L1	L	F	Y	h min	inch	
M4 x 0.3	3.0	0.3	3.0SIR0.3ISO...	.63	1.97	.05	.01	.007	.13	SMC...-3.0	
M4 x 0.4		0.4	3.0SIR0.4ISO...	.63	1.97	.05	.01	.009	.13		
M4 x 0.5		0.5	3.0SIR0.5ISO...	.63	1.97	.05	.02	.011	.13		
M4 x 0.6		0.6	3.0SIR0.6ISO...	.63	1.97	.05	.02	.014	.13		
M4.5 x 0.7		0.7	3.0SIR0.7ISO...	.63	1.97	.06	.02	.016	.13		
M4.5 x 0.75		0.75	3.0SIR0.75ISO...	.63	1.97	.06	.02	.017	.13		
M5 x 0.8	4.0	0.8	3.0SIR0.8ISO...	.63	1.97	.06	.02	.018	.13	SMC...-4.0	
M5 x 0.4		0.4	4.0SIR0.4ISO...	.63	1.97	.06	.01	.009	.16		
M5 x 0.5		0.5	4.0SIR0.5ISO...	.63	1.97	.06	.02	.011	.16		
M5 x 0.6		0.6	4.0SIR0.6ISO...	.63	1.97	.07	.02	.014	.16		
M5 x 0.7		0.7	4.0SIR0.7ISO...	.63	1.97	.07	.02	.016	.16		
M5.5 x 0.75		0.75	4.0SIR0.75ISO...	.63	1.97	.07	.02	.017	.17		
M5.5 x 0.8	0.8	4.0SIR0.8ISO...	.63	1.97	.07	.02	.018	.17	SMC...-6.0		
M6 x 1	1.0	4.0SIR1.0ISO...	.63	1.97	.08	.04	.023	.17			
M6 x 0.5	0.5	6.0SIR0.5ISO...	.63	1.97	.07	.02	.011	.21			
M6.5 x 0.75	0.75	6.0SIR0.75ISO...	.63	1.97	.08	.02	.017	.22			
M7 x 1	1.0	6.0SIR1.0ISO...	.63	1.97	.09	.03	.023	.22			
M8 x 1.25	1.25	6.0SIR1.25ISO...	.63	1.97	.09	.04	.028	.23			
M10.5 x 1.5	1.5	6.0SIR1.5ISO...	.63	1.97	.10	.04	.034	.24			

Left handed tool supplied by request (Example: 3.0SIL0.3ISO...).

Micro - Single Ended

microscope

Thread	Insert Dia.	Pitch	Ordering Code		Helix °	Dimensions inch					Min. Bore Dia.	Toolholder
	d mm		mm	RH/LH		L1	F	Y	h min	L2 ref*	L ref	
M4x0.5	4.0	0.5	MS429TH0.50ISOL16R/L...	3.5	.63	.04	.02	.011	.72	1.39	.13	MH...-4.0
M5x0.5		0.5	MS439TH0.50ISOL16R/L...			.07	.02	.011			.17	
M4x0.7		0.7	MS429TH0.70ISOL16R/L...			.04	.02	.016			.13	
M5x0.8		0.8	MS429TH0.80ISOL16R/L...			.04	.02	.018			.16	
M6x1.0		1.0	MS439TH1.00ISOL16R/L...			.07	.03	.023			.19	
M5.5x0.5		5.0	0.5			MS42TH0.50ISOL16R/L...	3	.63			.07	
M5.5x0.75	0.75		M542TH0.75ISOL16R/L...	.07	.02	.017			.18			
M7x1.0	1.0		M549TH1.00ISOL16R/L...	.09	.03	.023			.23			
M6x0.5	0.5		M649TH0.50ISOL16R/L...	.07	.02	.011			.21			
M6.5x0.75	0.75		M649TH0.75ISOL16R/L...	.07	.02	.017			.22			
M7.5x1.0	6.0		1.0	M659TH1.00ISOL16R/L...	3	.63			.11	.03	.023	.73
M8x1.25		1.25	M659TH1.25ISOL16R/L...	.11			.04	.028	.25			
M10x1.5		1.5	M659TH1.50ISOL16R/L...	.11			.04	.034	.25			

* L2 Ref: Repeatability within +/-0.0008

American UN - UNC, UNF, UNEF, UNS

External

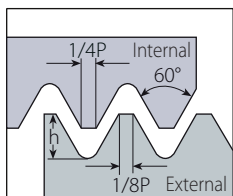

Defined by: ANSI B1.1:74
Tolerance class: 2A/2B

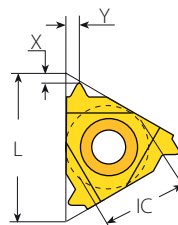

Standard

Standard

Insert Size		Pitch	Ordering Code		Dimensions inch			Anvil		Toolholder
IC	L inch	TPI	RH	LH	h min	X	Y	RH	LH	
1/4"	.43	72	2ER72UN...	2EL72UN...	.009	.03	.02	-	-	NL..-2 (LH)
		64	2ER64UN...	2EL64UN...	.009	.03	.02			
		56	2ER56UN...	2EL56UN...	.011	.03	.02			
		48	2ER48UN...	2EL48UN...	.013	.02	.02			
		44	2ER44UN...	2EL44UN...	.014	.02	.02			
		40	2ER40UN...	2EL40UN...	.015	.02	.02			
		36	2ER36UN...	2EL36UN...	.017	.02	.02			
		32	2ER32UN...	2EL32UN...	.019	.02	.02			
		28	2ER28UN...	2EL28UN...	.022	.02	.03			
		27	2ER27UN...	2EL27UN...	.023	.03	.03			
		24	2ER24UN...	2EL24UN...	.026	.03	.03			
		20	2ER20UN...	2EL20UN...	.031	.03	.04			
		18	2ER18UN...	2EL18UN...	.034	.03	.04			
		16	2ER16UN...	2EL16UN...	.038	.04	.04			
14	2ER14UN...	2EL14UN...	.044	.04	.04					
3/8"	.63	80	3ER80UN...	3EL80UN...	.007	.03	.01	YE3	YI3	AL..-3 (LH)
		72	3ER72UN...	3EL72UN...	.009	.03	.02			
		64	3ER64UN...	3EL64UN...	.009	.03	.02			
		56	3ER56UN...	3EL56UN...	.011	.03	.02			
		48	3ER48UN...	3EL48UN...	.013	.02	.02			
		44	3ER44UN...	3EL44UN...	.014	.02	.02			
		40	3ER40UN...	3EL40UN...	.015	.02	.02			
		36	3ER36UN...	3EL36UN...	.017	.02	.02			
		32	3ER32UN...	3EL32UN...	.019	.02	.02			
		28	3ER28UN...	3EL28UN...	.022	.02	.03			
		27	3ER27UN...	3EL27UN...	.023	.03	.03			
		26	3ER26UN...	3EL26UN...	.023	.03	.03			
		24	3ER24UN...	3EL24UN...	.026	.03	.03			
		20	3ER20UN...	3EL20UN...	.031	.03	.04			
		18	3ER18UN...	3EL18UN...	.034	.03	.04			
		16	3ER16UN...	3EL16UN...	.038	.04	.04			
		14	3ER14UN...	3EL14UN...	.044	.04	.05			
		13	3ER13UN...	3EL13UN...	.047	.04	.05			
		12	3ER12UN...	3EL12UN...	.051	.04	.06			
		11.5	3ER11.5UN...	3EL11.5UN...	.053	.04	.06			
11	3ER11UN...	3EL11UN...	.056	.04	.06					
10	3ER10UN...	3EL10UN...	.061	.04	.06					
9	3ER9UN...	3EL9UN...	.068	.05	.07					
8	3ER8UN...	3EL8UN...	.077	.05	.06					



American UN - UNC, UNF, UNEF, UNS (con't)

External

Defined by: ANSI B1.1:74
Tolerance class: 2A/2B

SCB
Sintered
Chipbreaker

V6

Standard

F-Line

U Style

Standard

	Insert Size		Pitch	Ordering Code		Dimensions inch			Anvil		Toolholder
	IC	L inch	TPI	RH	LH	h min	X	Y	RH	LH	
 SCB	3/8"	.63	36	3JER36UN...		.017	.05	.02	YE3	-	AL..-3
			32	3JER32UN...		.019	.05	.02			
			28	3JER28UN...		.022	.03	.03			
			24	3JER24UN...		.026	.03	.03			
			20	3JER20UN...		.031	.03	.03			
			18	3JER18UN...		.034	.03	.03			
			16	3JER16UN...		.038	.03	.03			
			14	3JER14UN...		.044	.05	.06			
			13	3JER13UN...		.047	.05	.06			
			12	3JER12UN...		.051	.05	.06			
			10	3JER10UN...		.061	.05	.06			
 V6	3/8"	.63	32	3ER32UN-6C...		.019	.08	.07	YE3-6C	-	AL..-3
			28	3ER28UN-6C...		.022	.08	.08			
			24	3ER24UN-6C...		.026	.07	.08			
			20	3ER20UN-6C...		.031	.07	.08			
			18	3ER18UN-6C...		.034	.07	.09			
			16	3ER16UN-6C...		.038	.07	.09			
			14	3ER14UN-6C...		.044	.07	.11			
	1/2"	.87	7	4ER7UN...	4EL7UN...	.087	.06	.09	YE4	YI4	AL..-4 (LH)
			6	4ER6UN...	4EL6UN...	.102	.06	.09			
			5	4ER5UN...	4EL5UN...	.123	.07	.10			
	1/2"F	.91	7	4FER7UN...		.087	.06	.09	YE4F		AL..-4F
			6	4FER6UN...		.102	.06	.09			
	5/8"	1.06	4.5	5ER4.5UN...	5EL4.5UN...	.136	.07	.11	YE5	YI5	AL..-5 (LH)
			4	5ER4UN...	5EL4UN...	.153	.08	.12			

U Style

	Insert Size		Pitch	Ordering Code	Dimensions inch			Anvil		Toolholder
	IC	L inch	TPI	RH+LH	h min	X	Y	RH	LH	
	1/2"U	.87	4.5	4UE4.5UN...	.136	.08	.43	YE4U	YI4U	AL..-4U (LH)
			4	4UE4UN...	.153	.08	.43			
	5/8"U	1.06	3	5UE3UN...	.204	.10	.54	YE5U	YI5U	AL..-5U (LH)

American UN - UNC, UNF, UNEF, UNS (con't)

External

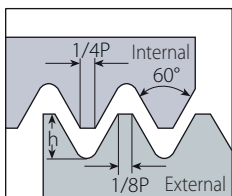

Defined by: ANSI B1.1:74
Tolerance class: 2A/2B

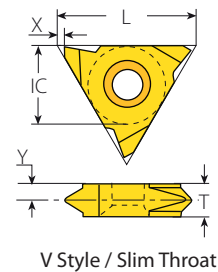

Slim Throat



Insert Size		Pitch	Ordering Code		Dimensions inch				Toolholder
IC	L inch	TPI	RH	LH	h min	X	Y	T	
1/4"V	.43	20	2VER20UN...	2VEL20UN...	.031	.03	.09	.13	NL..-2V (LH)
		18	2VER18UN...	2VEL18UN...	.034	.03	.09	.13	
		16	2VER16UN...	2VEL16UN...	.038	.03	.09	.13	
		14	2VER14UN...	2VEL14UN...	.044	.03	.08	.13	
		12	2VER12UN...	2VEL12UN...	.051	.03	.07	.13	
3/8"V	.63	32	3VER32UN...	3VEL32UN...	.019	.04	.12	.14	NL..-3V (LH)
		28	3VER28UN...	3VEL28UN...	.022	.04	.12	.14	
		24	3VER24UN...	3VEL24UN...	.026	.04	.11	.14	
		20	3VER20UN...	3VEL20UN...	.031	.04	.11	.14	
		18	3VER18UN...	3VEL18UN...	.034	.04	.10	.14	
		16	3VER16UN...	3VEL16UN...	.038	.04	.10	.14	
		14	3VER14UN...	3VEL14UN...	.044	.04	.09	.14	
		12	3VER12UN...	3VEL12UN...	.051	.04	.09	.14	
10	3VER10UN...	3VEL10UN...	.061	.04	.08	.14			
8	3VER8UN...	3VEL8UN...	.077	.04	.08	.14			
1/2"V	.87	7	4VER7UN...	4VEL7UN...	.087	.04	.10	.19	NL..-4V (LH)

V Style



Insert Size		Pitch	Ordering Code		Dimensions inch				Toolholder
IC	L inch	TPI	RH	LH	h min	X	Y	T	
5/8"V	1.06	4	5VER4UN...	5VEL4UN...	.153	.04	.13	.24	NL..-5V-6 (LH)
		3	5VER3UN...	5VEL3UN...	.204	.04	.17	.31	NL..-5V-8 (LH)

American UN - UNC, UNF, UNEF, UNS (con't)

External

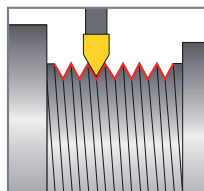
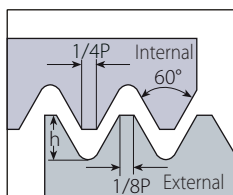

Defined by: ANSI B1.1:74
Tolerance class: 2A/2B

RS/LS Varied range of threading standards for machining between shoulders and close to spindle.

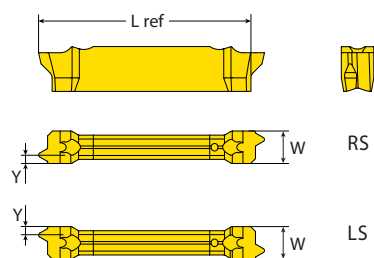

VG-Cut



Pocket Size	Ordering Code	Dimensions inch					No. of Passes	Helix		Min. Thread Diameter	Toolholder
		RH	W ref	Pitch TPI	h min	Y		L ref	Deg		
3	VGD3.0UN32RH-RS/LS...			32	.019	.03	5 - 8			5/32"-32 UNC	Monoblock VGE...T12
	VGD3.0UN28RH-RS/LS...			28	.022	.03	5 - 9			3/16"-28 UNC	
	VGD3.0UN24RH-RS/LS...			24	.026	.03	5 - 9			7/32"-24 UNC	
	VGD3.0UN20RH-RS/LS...		.12	20	.031	.03	6 - 10	2.5°		1/4"-20 UNC	
	VGD3.0UN18RH-RS/LS...			18	.034	.04	7 - 12			5/16"-18 UNC	
	VGD3.0UN16RH-RS/LS...			16	.038	.04	7 - 12			3/8"-16 UNC	
	VGD3.0UN14RH-RS/LS...			14	.044	.04	8 - 14			7/16"-14 UNC	
	VGD3.0UN12RH-RS/LS...			12	.051	.05	8 - 14			9/16"-14 UNC	

LH Helix threads available upon request.

American UN - UNC, UNF, UNEF, UNS (con't)

External

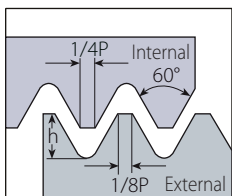

Defined by: ANSI B1.1:74
Tolerance class: 2A/2B

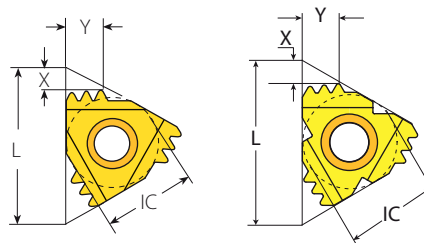

M+ Style

F-Line M+

M+ Style



FLINE

Insert Size		Pitch	Teeth	Ordering Code	Dimensions inch			Anvil	Toolholder	
IC	L inch	TPI		RH	h min	X	Y	RH		
3/8"	.63	20	3	3ER20UN3M+...		.031	.09	.13	YE3M	AL...-3
		18	2	3ER18UN2M+...		.034	.06	.09		
		18	3	3ER18UN3M+...		.034	.09	.14		
		16	2	3ER16UN2M+...		.038	.07	.10		
		14	2	3ER14UN2M+...		.044	.07	.11		
1/2"	.87	16	3	4ER16UN3M+...		.038	.10	.16	YE4M	AL...-4
		14	2	4ER14UN2M+...		.044	.07	.11		
		12	2	4ER12UN2M+...		.051	.09	.13		
		12	3	4ER12UN3M+...		.051	.13	.21		
		11	2	4ER11UN2M+...		.056	.09	.14		
1/2"F	.91	16	3	4FER16UN3M+...		.038	.10	.16	YE4M3F	AL...-4MF
		12	3	4FER12UN3M+...		.051	.13	.21		
		12	2	4FER12UN2M+...		.051	.09	.13	YE4M2F	
		10	2	4FER10UN2M+...		.061	.10	.15		
5/8"	1.06	8	2	5ER8UN2M+...		.077	.12	.19	YE5M	AL...-5M

American UN - UNC, UNF, UNEF, UNS (con't)

Internal

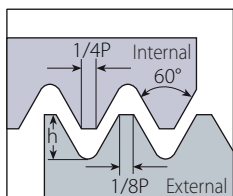

Defined by: ANSI B1.1:74
Tolerance class: 2A/2B

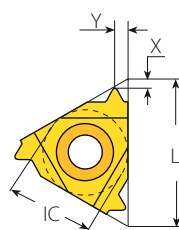

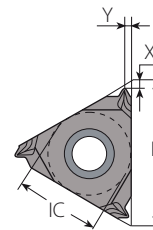

Standard



SCB
Sintered
Chipbreaker

Standard

Insert Size		Pitch	Ordering Code		Dimensions inch			Anvil		Toolholder	
IC	L inch	TPI	RH	LH	h min	X	Y	RH	LH		
	1/4"	.43	72	2IR72UN...	2IL72UN...	.008	.03	.01	-	-	NVR..-2 (LH)
			64	2IR64UN...	2IL64UN...	.009	.03	.02			
			56	2IR56UN...	2IL56UN...	.010	.03	.02			
			48	2IR48UN...	2IL48UN...	.012	.02	.02			
			44	2IR44UN...	2IL44UN...	.013	.02	.02			
			40	2IR40UN...	2IL40UN...	.015	.02	.02			
			36	2IR36UN...	2IL36UN...	.016	.02	.02			
			32	2IR32UN...	2IL32UN...	.018	.02	.02			
			28	2IR28UN...	2IL28UN...	.020	.02	.03			
			27	2IR27UN...	2IL27UN...	.021	.03	.03			
			24	2IR24UN...	2IL24UN...	.024	.03	.03			
			20	2IR20UN...	2IL20UN...	.029	.03	.04			
			18	2IR18UN...	2IL18UN...	.032	.03	.04			
			16	2IR16UN...	2IL16UN...	.036	.04	.04			
			14	2IR14UN...	2IL14UN...	.041	.04	.04			
12	2IR12UN...	2IL12UN...	.048	.03	.04						
11	2IR11UN...	2IL11UN...	.052	.03	.04						
	1/4" SCB	.43	36	2JIR36UN...		.016	.04	.02	-	-	NVR..-2
			32	2JIR32UN...		.018	.05	.02			
			28	2JIR28UN...		.020	.02	.03			
			24	2JIR24UN...		.024	.03	.03			
			20	2JIR20UN...		.029	.02	.03			
			18	2JIR18UN...		.032	.02	.03			
16	2JIR16UN...		.038	.03	.03						
	3/8"	.63	72	3IR72UN...	3IL72UN...	.008	.03	.01	Y13	YE3	AVR..-3 (LH)
			64	3IR64UN...	3IL64UN...	.009	.03	.02			
			56	3IR56UN...	3IL56UN...	.010	.03	.02			
			48	3IR48UN...	3IL48UN...	.012	.02	.02			
			44	3IR44UN...	3IL44UN...	.013	.02	.02			
			40	3IR40UN...	3IL40UN...	.015	.02	.02			
			36	3IR36UN...	3IL36UN...	.016	.02	.02			
			32	3IR32UN...	3IL32UN...	.020	.02	.02			
			28	3IR28UN...	3IL28UN...	.020	.02	.03			
			27	3IR27UN...	3IL27UN...	.021	.03	.03			
			26	3IR26UN...	3IL26UN...	.022	.03	.03			

American UN - UNC, UNF, UNEF, UNS (con't)

Internal

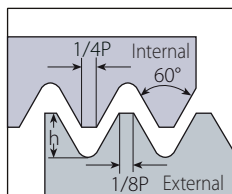

Defined by: ANSI B1.1:74
Tolerance class: 2A/2B

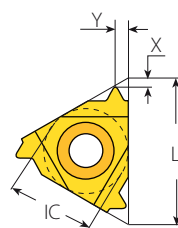

Standard

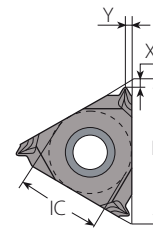

SCB
Sintered
Chipbreaker

Standard



SCB

Insert Size		Pitch	Ordering Code		Dimensions inch			Anvil		Toolholder
IC	L inch	TPI	RH	LH	h min	X	Y	RH	LH	
3/8"	.63	24	3IR24UN...	3IL24UN...	.024	.03	.03	Y13	YE3	AVR..-3 (LH)
		20	3IR20UN...	3IL20UN...	.029	.03	.04			
		18	3IR18UN...	3IL18UN...	.032	.03	.04			
		16	3IR16UN...	3IL16UN...	.036	.04	.04			
		14	3IR14UN...	3IL14UN...	.041	.04	.05			
		13	3IR13UN...	3IL13UN...	.044	.04	.05			
		12	3IR12UN...	3IL12UN...	.048	.04	.06			
		11.5	3IR11.5UN...	3IL11.5UN...	.050	.04	.06			
		11	3IR11UN...	3IL11UN...	.052	.04	.06			
		10	3IR10UN...	3IL10UN...	.058	.04	.06			
9	3IR9UN...	3IL9UN...	.064	.05	.07					
8	3IR8UN...	3IL8UN...	.072	.04	.06					
3/8" SCB	.63	28	3JIR28UN...		.020	.02	.03	Y13	-	AVR..-3
		24	3JIR24UN...		.024	.03	.03			
		20	3JIR20UN...		.029	.02	.03			
		18	3JIR18UN...		.032	.02	.03			
		16	3JIR16UN...		.036	.03	.03			
		14	3JIR14UN...		.041	.04	.06			
		13	3JIR13UN...		.044	.04	.06			
		12	3JIR12UN...		.048	.04	.06			
		10	3JIR10UN...		.058	.04	.06			
		9	3JIR9UN...		.064	.04	.06			
8	3JIR8UN...		.072	.04	.06					

American UN - UNC, UNF, UNEF, UNS (con't)

Internal

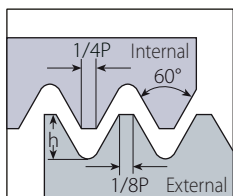

Defined by: ANSI B1.1:74
Tolerance class: 2A/2B

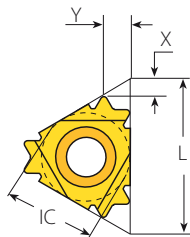

V6

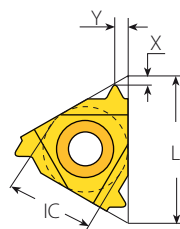

Standard

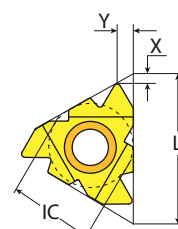

F-Line

Standard



FLINE

Insert Size		Pitch	Ordering Code		Dimensions inch			Anvil		Toolholder	
IC	L inch	TPI	RH	LH	h min	X	Y	RH	LH		
3/8" V6	.63	32	3IR32UN-6C...			.020	.08	.07	Y13-6C	-	AVR..-3 NVRC..-3V6
		28	3IR28UN-6C...			.020	.07	.07			
		24	3IR24UN-6C...			.024	.07	.07			
		20	3IR20UN-6C...			.029	.07	.08			
		18	3IR18UN-6C...			.032	.07	.08			
		16	3IR16UN-6C...			.036	.06	.09			
		14	3IR14UN-6C...			.041	.07	.10			
		13	3IR13UN-6C...			.044	.07	.11			
1/2"	.87	7	4IR7UN...	4IL7UN...		.082	.06	.09	Y14	YE4	AVR..-4 (LH)
		6	4IR6UN...	4IL6UN...		.096	.06	.09			
		5	4IR5UN...	4IL5UN...		.115	.06	.09			
1/2" ^F	.91	7	4FIR7UN...			.082	.06	.09	Y14 ^F		AVRC...-4 ^F
		6	4FIR6UN...			.096	.06	.09			
5/8"	1.06	4.5	5IR4.5UN...	5IL4.5UN...		.128	.07	.09	Y15	YE5	AVR..-5 (LH)
		4	5IR4UN...	5IL4UN...		.144	.07	.11			

American UNC (con't)

Internal

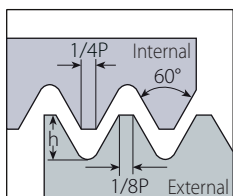

Defined by: ANSI B1.1:74
Tolerance class: 2A/2B

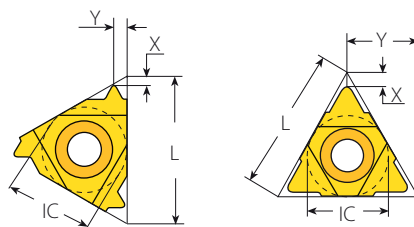

Coarse Pitch

U Style Coarse Pitch

Coarse Pitch RH



	Thread	Insert Size		Ordering Code	Dimensions inch			Toolholder RH	Min Bore Dia. inch
		IC	L inch		RH	h min	X		
	1/2" x 13UN	6.0	.39	6.0KIR13UN158/001...	.044	.03	.04	BNVRC0375S-6.0K	.42
	9/16" x 12UN	1/4"	.43	2IR12UN158/002...	.048	.04	.04	NVRC040-2-157/001	.47
	5/8" x 11UN	1/4"U		2UIR11UN158/003...	.052	.05	.22	NVRC044-2U-157/002	.53
	3/4" x 10UN			3IR10UN...	.058	.04	.06	NVRC050-3-157/016	.64
	7/8" x 9UN	3/8"	.63	3IR9UN...	.064	.05	.07	NVRC050-3-157/016	.76
	1" x 8UN			3IR8UN...	.072	.04	.06	NVRC0625-3	.87
	1 1/8" x 7UN		.87	4IR7UN...	.082	.06	.09	NVRC075-4	.97
	1 1/4" x 7UN	1/2"		4IR7UN...	.082	.06	.09	NVRC075-4	1.09
	1 3/8" x 6UN			4IR6UN...	.096	.06	.09	NVRC075-4	1.19

Coarse Pitch LH



	Thread	Insert Size		Ordering Code	Dimensions inch			Toolholder LH	Min Bore Dia. inch
		IC	L inch		LH	h min	X		
	1/2" x 13UN	6.0	.39	6.0KIL13UN158/016...	.044	.03	.04	BNVRC0375S-6.0KLH	.42
	9/16" x 12UN	1/4"	.43	2IL12UN158/017...	.048	.04	.04	NVRC040-2LH-157/025	.47
	5/8" x 11UN	1/4"U		2UIR11UN158/003...	.052	.05	.22	NVRC044-2ULH-157/026	.53
	3/4" x 10UN			3IL10UN...	.058	.04	.06	NVRC050-3LH-157/035	.64
	7/8" x 9UN	3/8"	.63	3IL9UN...	.064	.05	.07	NVRC050-3LH-157/035	.76
	1" x 8UN			3IL8UN...	.072	.04	.06	NVRC0625-3LH	.87
	1 1/8" x 7UN		.87	4IL7UN...	.082	.06	.09	NVRC075-4LH	.97
	1 1/4" x 7UN	1/2"		4IL7UN...	.082	.06	.09	NVRC075-4LH	1.09
	1 3/8" x 6UN			4IL6UN...	.096	.06	.09	NVRC075-4LH	1.19

U Type RH inserts can be used for both LH and RH applications.

American UN - UNC, UNF, UNEF, UNS (con't)

Internal

Defined by: ANSI B1.1:74
Tolerance class: 2A/2B

U Style



Insert Size		Pitch	Ordering Code		Dimensions inch			Anvil		Toolholder
IC	L inch	TPI	RH+LH	h min	X	Y	RH	LH		
1/2"U	.87	4.5	4UI4.5UN...	.128	.09	.43	YI4U	YE4U	AVR..-4U (LH)	
		4	4UI4UN...	.144	.09	.43				
5/8"U	1.06	3	5UI3UN...	.193	.11	.54	YI5U	YE5U	AVR..-5U (LH)	

V Style



Insert Size		Pitch	Ordering Code		Dimensions inch					Toolholder
IC	L inch	TPI	RH	LH	h min	X	Y	T		
5/8"V	1.06	4	5VIR4UN...	5VIL4UN...	.144	.04	.13	.24	NVR..-5V (LH)	
		3	5VIR3UN...	5VIL3UN...	.193	.04	.17	.31		

M+ Style

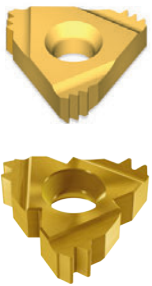

F-LINE

Insert Size		Pitch	Teeth	Ordering Code		Dimensions inch			Anvil	
IC	L inch	TPI		RH	LH	h min	X	Y	RH	Toolholder
3/8"	.63	12	2	3IR12UN2M+...		.048	.09	.13	YI3M	AVR..-3
		14	2	3IR14UN2M+...		.041	.07	.11		
		16	2	3IR16UN2M+...		.036	.07	.10		
1/2"	.87	16	3	4IR16UN3M+...		.036	.10	.16	YI4M	AVR..-4
		14	2	4IR14UN2M+...		.041	.07	.11		
		12	2	4IR12UN2M+...		.048	.09	.13		
1/2"F	.91	12	2	4FIR12UN2M+...		.048	.09	.13	YI4M2F	AVRC...-4MF
5/8"	1.06	8	2	5IR8UN2M+...		.072	.12	.19	YI5M	AVR..-5M

American UN - UNC, UNF, UNEF, UNS (con't)

Mini-V

Internal

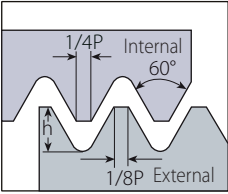

Defined by: ANSI B1.1:74
Tolerance class: 2A/2B

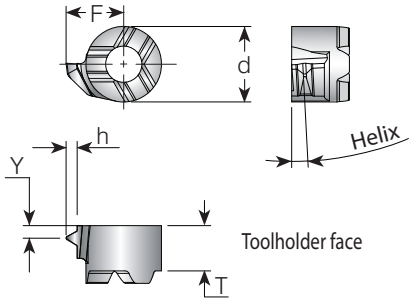

Mini-V



Min. Thread	Insert Style	Pitch	Ordering Code	Dimensions inch						Helix	Toolholder
				TPI	RH	d	T	F	Y		
3/8"-32UNEF	V08	32	V08TH32UNR...	.24	.15	.17	.02	.018	1.5	.V08-...	
3/8"-28UN		28	V08TH28UNR...			.17	.02	.020	2		
3/8"-24UNF		24	V08TH24UNR...			.17	.03	.024	2		
3/8"-20UN		20	V08TH20UNR...			.18	.03	.029	2.5		
3/8"-18UNS		18	V08TH18UNR...			.18	.03	.032	2.5		
3/8"-16UNC		16	V08TH16UNR...			.17	.04	.036	2.5		
7/16"-14UNC	V11	14	V08TH14UNR...	.31	.17	.19	.04	.041	3	.V11-...	
9/16"-12UNC		12	V11TH12UNR...			.25	.05	.048	2.5		

American UN - UNC, UNF, UNEF, UNS (con't)

Internal

Defined by: ANSI B1.1:74
Tolerance class: 2A/2B

Mini-3 Standard

Insert Size	Pitch		Ordering Code		Dimensions inch			Min. Bore Dia.	Toolholder
	IC mm	L inch	TPI	RH	LH	h min	Y	F	
4.0	.24	32	4.0KIR32UN...	4.0KIL32UN...	.018	.02	.14	.24	.NVR...-4.0K (LH)
		28	4.0KIR28UN...	4.0KIL28UN...	.020	.02	.14	.24	
		24	4.0KIR24UN...	4.0KIL24UN...	.024	.02	.14	.25	
		20	4.0KIR20UN...	4.0KIL20UN...	.029	.02	.15	.25	
		18	4.0KIR18UN...	4.0KIL18UN...	.032	.03	.15	.25	
5.0	.31	32	5.0KIR32UN...	5.0KIL32UN...	.018	.02			.NVR...-5.0K (LH)
		28	5.0KIR28UN...	5.0KIL28UN...	.020	.02			
		24	5.0KIR24UN...	5.0KIL24UN...	.024	.02			
		20	5.0KIR20UN...	5.0KIL20UN...	.029	.03	.19	.31	
		18	5.0KIR18UN...	5.0KIL18UN...	.032	.03			
		16	5.0KIR16UN...	5.0KIL16UN...	.036	.03			
6.0	.39	40	6.0KIR40UN...	6.0KIL40UN...	.015	.02	.18	.37	.NVR...-6.0K (LH)
		32	6.0KIR32UN...	6.0KIL32UN...	.018	.02	.18	.37	
		28	6.0KIR28UN...	6.0KIL28UN...	.020	.03	.19	.38	
		24	6.0KIR24UN...	6.0KIL24UN...	.024	.03	.19	.38	
		20	6.0KIR20UN...	6.0KIL20UN...	.029	.04	.19	.39	
		18	6.0KIR18UN...	6.0KIL18UN...	.032	.04	.20	.39	
		16	6.0KIR16UN...	6.0KIL16UN...	.036	.04	.20	.39	
14	6.0KIR14UN...	6.0KIL14UN...	.041	.04	.20	.39			

Mini-3 U Style

Insert Size	Pitch		Ordering Code		Dimensions inch			Min. Bore Dia.	Toolholder
	IC mm	L inch	TPI	RH+LH	h min	Y	F	inch	
5.0U	.31	13	5.0KUI13UN...		.047		.22	.35	.NVR...-5.0KU (LH)
		12	5.0KUI12UN...		.051	.16	.22		
		11	5.0KUI11UN...		.056		.22		

Mini-L

Insert Size	Pitch		Ordering Code		Dimensions inch			Min. Bore Dia.	Toolholder
	IC mm	TPI	RH	LH	h min	Y	F	inch	
5.0L		40	5LKIR40UN...	5LKIL40UN...	.015	.02	.15	.30	.NVR...-5LK (LH)
		32	5LKIR32UN...	5LKIL32UN...	.018	.02	.15	.30	
		28	5LKIR28UN...	5LKIL28UN...	.020	.03	.16	.30	
		24	5LKIR24UN...	5LKIL24UN...	.024	.03	.16	.30	
		20	5LKIR20UN...	5LKIL20UN...	.029	.04	.17	.30	
		18	5LKIR18UN...	5LKIL18UN...	.032	.04	.17	.31	
		16	5LKIR16UN...	5LKIL16UN...	.036	.04	.17	.31	
		14	5LKIR14UN...	5LKIL14UN...	.041	.04	.18	.31	

American UN - UNC, UNF, UNEF, UNS (con't)

MINIPRO

Internal

Defined by: ANSI B1.1:74
Tolerance class: 2A/2B

RH-Single Ended **RH-Double Ended**

Micro - Double Ended

Thread	Insert Dia.	Pitch	Ordering Code		Dimensions inch					Min. Bore Dia.	Toolholder
	d mm		RH	L1	L	F	Y	h min	Inch		
10-40UNS	3.0	40	3.0SIR40UN...	.63	1.97	.05	.02	.015	.13	SMC..-3.0	
8-36UNF		36	3.0SIR36UN...	.63	1.97	.06	.02	.016	.13		
8-32UNF		32	3.0SIR32UN...	.63	1.97	.06	.02	.018	.13		
10-40UNS	4.0	40	4.0SIR40UN...	.63	1.97	.06	.02	.015	.16	SMC..-4.0	
10-36UNS		36	4.0SIR36UN...	.63	1.97	.07	.02	.016	.16		
12-32UNEF		32	4.0SIR32UN...	.63	1.97	.07	.02	.018	.16		
12-28UNF	4.0	28	4.0SIR28UN...	.63	1.97	.07	.03	.020	.17	SMC..-4.0	
1/4"-27UNS		27	4.0SIR27UN...	.63	1.97	.07	.03	.021	.17		
12-24UNC		24	4.0SIR24UN...	.63	1.97	.08	.03	.024	.17		
1/4"-20UNC	6.0	20	4.0SIR20UN...	.63	1.97	.08	.03	.029	.17	SMC..-6.0	
1/4"-32UNEF		32	6.0SIR32UN...	.63	1.97	.08	.02	.018	.22		
5/16"-28UN		28	6.0SIR28UN...	.63	1.97	.08	.03	.020	.22		
5/16"-27UNS	6.0	27	6.0SIR27UN...	.63	1.97	.08	.03	.021	.22	SMC..-6.0	
5/16"-24UNF		24	6.0SIR24UN...	.63	1.97	.09	.03	.024	.22		
5/16"-20UN		20	6.0SIR20UN...	.63	1.97	.09	.04	.029	.23		
5/16"-18UNC	6.0	18	6.0SIR18UN...	.63	1.97	.09	.04	.032	.23	SMC..-6.0	
3/8"-16UNC		16	6.0SIR16UN...	.63	1.97	.10	.04	.036	.24		

Left handed tool supplied by request (Example: 6.0SIL16UN...).

Micro - Single Ended

microscope

Thread	Insert Dia.	Pitch	Ordering Code		Helix °	L1	Dimensions inch					Min. Bore Dia.	Toolholder
	d mm		TPI	RH/LH			F	Y	h min	L2 ref*	L ref	D inch	
No.8-32UNC	4.0	32	MS429TH32UNL16R/L...	3.5	.63	.04	.02	.018	.72	1.39	.13	MH...-4.0	
No.10-28UNS		28	MS429TH28UNL16R/L...			.04	.03	.020			.14		
1/4"-27UNS	5.0	27	M549TH27UNL16R/L...	3.5	.63	.09	.03	.021	.72	1.62	.21	MH...-5.0	
1/4"-24UNS		24	M542TH24UNL16R/L...			.07	.03	.024			.20		
1/4"-20UNC	6.0	20	M542TH20UNL16R/L...	3.5	.63	.07	.04	.029	.73	1.66	.18	MH...-6.0	
5/16"-18UNC		18	M659TH18UNL16R/L...			.11	.04	.032			.25		
3/8"-16UNC		16	M659TH16UNL16R/L...			.11	.04	.036			.30		

* L2 Ref: Repeatability within +/- .0008

American UNR

External

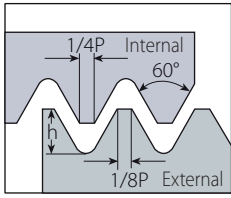

Defined by: ASME B1.1-2003
Tolerance class: 2A/2B

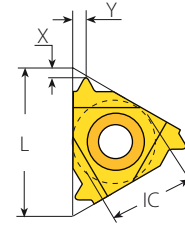

Standard External

Standard - External



Insert Size		Pitch	Ordering Code		Dimensions inch			Anvil		Toolholder
IC	L inch	TPI	RH	LH	h min	X	Y	RH	LH	
3/8"	.63	8	3ER8UNR...	3EL8UNR...	.077	.05	.06	YE3	YI3	AL...-3 (LH)

Whitworth - BSW, BSP, BSF, BSB

External

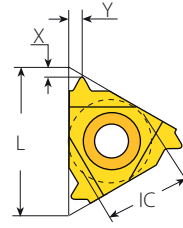
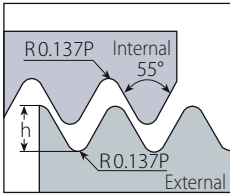

Defined by: B.S.84:1956, DIN 259, ISO228/1:1982
Tolerance class: Medium class A

Standard

Standard

Insert Size		Pitch	Ordering Code		Dimensions inch			Anvil		Toolholder
IC	L inch	TPI	RH	LH	h min	X	Y	RH	LH	
1/4"	.43	72	2ER72W...	2EL72W...	.009	.03	.02	-	-	NL ...-2 (LH)
		60	2ER60W...	2EL60W...	.011	.03	.02			
		56	2ER56W...	2EL56W...	.011	.03	.02			
		48	2ER48W...	2EL48W...	.013	.02	.02			
		40	2ER40W...	2EL40W...	.016	.02	.02			
		36	2ER36W...	2EL36W...	.018	.02	.02			
		32	2ER32W...	2EL32W...	.020	.02	.02			
		28	2ER28W...	2EL28W...	.023	.02	.03			
		26	2ER26W...	2EL26W...	.025	.03	.03			
		24	2ER24W...	2EL24W...	.027	.03	.03			
		22	2ER22W...	2EL22W...	.029	.03	.04			
		20	2ER20W...	2EL20W...	.032	.03	.04			
		19	2ER19W...	2EL19W...	.034	.03	.04			
		18	2ER18W...	2EL18W...	.035	.03	.04			
3/8"	.63	72	3ER72W...	3EL72W...	.009	.03	.02	YE3	YI3	AL...-3 (LH)
		60	3ER60W...	3EL60W...	.011	.03	.02			
		56	3ER56W...	3EL56W...	.011	.03	.02			
		48	3ER48W...	3EL48W...	.013	.02	.02			
		40	3ER40W...	3EL40W...	.016	.02	.02			
		36	3ER36W...	3EL36W...	.018	.02	.02			
		32	3ER32W...	3EL32W...	.020	.02	.02			
		30	3ER30W...	3EL30W...	.022	.02	.03			
		28	3ER28W...	3EL28W...	.023	.02	.03			
		26	3ER26W...	3EL26W...	.025	.03	.03			
		24	3ER24W...	3EL24W...	.027	.03	.03			
		22	3ER22W...	3EL22W...	.029	.03	.04			
		20	3ER20W...	3EL20W...	.032	.03	.04			
		19	3ER19W...	3EL19W...	.034	.03	.04			
		18	3ER18W...	3EL18W...	.035	.03	.04			
		16	3ER16W...	3EL16W...	.040	.04	.04			
		14	3ER14W...	3EL14W...	.046	.04	.05			
		12	3ER12W...	3EL12W...	.054	.04	.06			
11	3ER11W...	3EL11W...	.058	.04	.06					
10	3ER10W...	3EL10W...	.064	.04	.06					
9	3ER9W...	3EL9W...	.071	.05	.07					
8	3ER8W...	3EL8W...	.080	.05	.06					



Whitworth - BSW, BSP, BSF, BSB (con't)

External

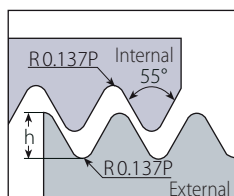

Defined by: B.S.84:1956,
DIN 259, ISO228/1:1982
Tolerance class: Medium class A

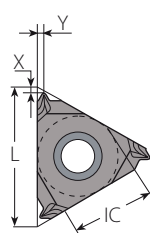

SCB
Sintered
Chipbreaker

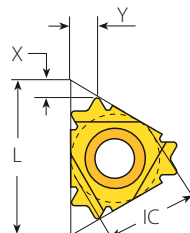

V6

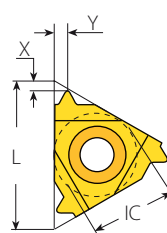

Standard

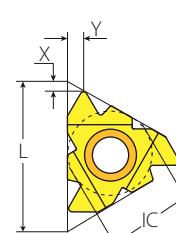



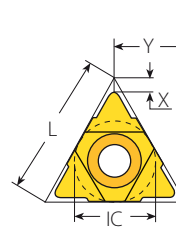

F-Line



U Style

Standard

IC	Insert Size		Pitch		Ordering Code		Dimensions inch			Anvil		Toolholder
	L inch	TPI	RH	LH	h min	X	Y	RH	LH			
 3/8" SCB	.63	36	3JER36W...		.018	.05	.02	YE3	-	AL..-3		
		32	3JER32W...		.020	.05	.02					
		28	3JER28W...		.023	.03	.03					
		24	3JER24W...		.027	.03	.03					
		20	3JER20W...		.032	.03	.03					
		19	3JER19W...		.034	.03	.03					
		18	3JER18W...		.035	.03	.03					
		16	3JER16W...		.040	.03	.03					
		14	3JER14W...		.046	.05	.06					
		12	3JER12W...		.054	.05	.06					
		11	3JER11W...		.058	.05	.06					
		10	3JER10W...		.064	.05	.06					
 3/8" V6	.63	19	3ER19W-6C...		.034	.07	.09	YE3-6C	-	AL..-3		
		16	3ER16W-6C...		.040	.06	.09					
		14	3ER14W-6C...		.046	.07	.11					
		12	3ER12W-6C...		.054	.07	.12					
 1/2"	.87	7	4ER7W...	4EL7W...	.095	.06	.09	YE4	Y14	AL..-4 (LH)		
		6	4ER6W...	4EL6W...	.107	.06	.09					
		5	4ER5W...	4EL5W...	.128	.07	.09					
		7	4FER7W...		.095	.06	.10					
 1/2" F	.91	6	4FER6W...		.107	.06	.09	YE4F		AL..-4F		
		5	4FER5W...		.128	.07	.09					
		4.5	5ER4.5W...	5EL4.5W...	.142	.07	.10					
 5/8"	1.06	4	5ER4W...	5EL4W...	.160	.08	.11	YE5	Y15	AL..-5 (LH)		

U Style

IC	Insert Size		Pitch		Ordering Code		Dimensions inch			Anvil		Toolholder
	L inch	TPI	RH+LH		h min	X	Y	RH	LH			
 1/2" U	.87	4.5	4UEI4.5W...		.142	.09	.43	YE4U	Y14U	AL..-4U (LH)		
		4	4UEI4W...		.160	.07	.43					
		3.5	4UEI3.5W...		.183	.08	.43					
		3.25	4UEI3.25W...		.197	.08	.43					
 5/8" U	1.06	3.5	5UEI3.5W...		.183	.08	.54	YE5U	Y15U	AL..-5U (LH)		
		3.25	5UEI3.25W...		.197	.08	.54					
		3	5UEI3W...		.213	.09	.54					
		2.75	5UEI2.75W...		.233	.09	.54					

Whitworth - BSW, BSP, BSF, BSB (con't)

External

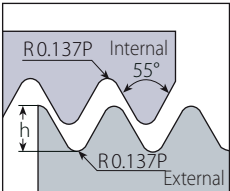

Defined by: B.S.84:1956, DIN 259, ISO228/1:1982
Tolerance class: Medium class A

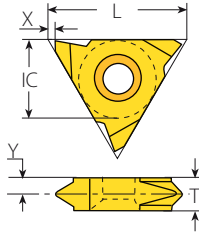

V Style / Slim Throat

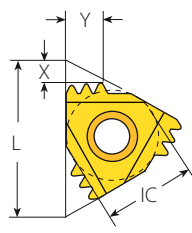

M+ Style

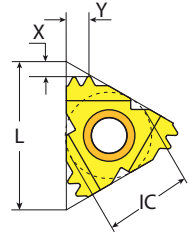

F-Line M+

Slim Throat



	Insert Size		Pitch	Ordering Code		Dimensions inch			Toolholder
	IC	L inch		TPI	RH	LH	h min	X	
1/4"V	.43	19	2VER19W...	2VEL19W...	.034	.03	.09	.13	NL...-2V (LH)
		14	2VER14W...	2VEL14W...	.046	.03	.08	.13	
		11	2VER11W...	2VEL11W...	.058	.03	.07	.13	
3/8"V	.63	19	3VER19W...	3VEL19W...	.034	.04	.11	.14	NL...-3V (LH)
		18	3VER18W...	3VEL18W...	.035	.04	.10	.14	
		16	3VER16W...	3VEL16W...	.040	.04	.10	.14	
		14	3VER14W...	3VEL14W...	.046	.04	.09	.14	
		12	3VER12W...	3VEL12W...	.054	.04	.09	.14	
		11	3VER11W...	3VEL11W...	.058	.04	.08	.14	

V Style



	Insert Size		Pitch	Ordering Code		Dimensions inch			Toolholder
	IC	L inch		TPI	RH	LH	h min	X	
5/8"V	1.06	4	5VER4W...	5VEL4W...	.160	.039	.13	.24	NL...-5V-6 (LH)
		3	5VER3W...	5VEL3W...	.213	.039	.17	.31	NL...-5V-8 (LH)
		2.5	5VER2.5W...	5VEL2.5W...	.256	.039	.21	.39	NL...-5V-10 (LH)

M+ Style



FLINE

	Insert Size		Pitch	Teeth	Ordering Code		Dimensions inch			Anvil	Toolholder
	IC	L inch			TPI	RH	h min	X	Y	RH	
3/8"	.63	28	2	3ER28W2M+...	.023	.05	.06	YE3M	AL...-3		
		19	2	3ER19W2M+...	.034	.06	.09				
		19	3	3ER19W3M+...	.034	.09	.13				
		14	2	3ER14W2M+...	.046	.08	.12				
1/2"	.87	14	3	4ER14W3M+...	.046	.11	.18	YE4M	AL...-4		
		11	2	4ER11W2M+...	.058	.09	.14				
1/2"F	.91	11	2	4FER11W2M+...	.058	.09	.14	YE4M2F	AL...-4MF		

Whitworth - BSW, BSP, BSF, BSB (con't)

External

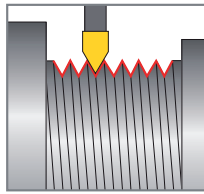
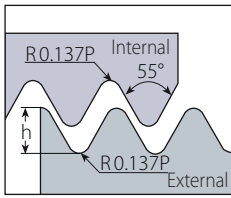

Defined by: B.S.84:1956, DIN 259, ISO228/1:1982
Tolerance class: Medium class A

RS/LS Varied range of threading standards for machining between shoulders and close to spindle.

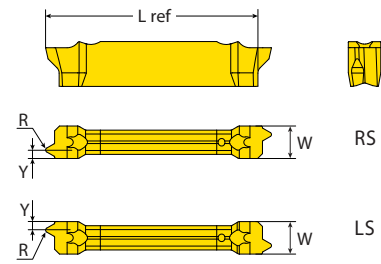

VG-Cut



Pocket Size	Ordering Code	Dimensions inch					No. of Passes	Helix	Min. Thread Diameter	Toolholder
		RH	W ref	Pitch TPI	h min	Y				
3	VGD3.0W19RH-RS/LS...		.12	19	.034	.04	.86	7-12	1/2"-19BSW	Monoblock VGE...T12
	VGD3.0W14RH-RS/LS...		.12	14	.046	.05	.86	8-14 2.5°	1/2"-14BSW	
	VGD3.0W11RH/LH...		.12	11	.060	.07	.86	8-14	5/8-11BSW	

LH Helix threads available upon request.

Whitworth - BSW, BSP, BSF, BSB (con't)

Internal

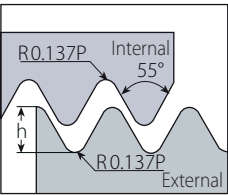

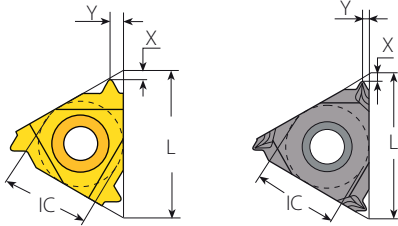

Defined by: B.S.84:1956, DIN 259, ISO228/1:1982
Tolerance class: Medium class A



Standard

SCB
Sintered
Chipbreaker

Standard

Insert Size		Pitch	Ordering Code		Dimensions inch			Anvil		Toolholder	
IC	L inch	TPI	RH	LH	h min	X	Y	RH	LH		
	1/4"	.43	72	2IR72W...	2IL72W...	.009	.03	.02	-	-	NVR..-2 (LH)
			60	2IR60W...	2IL60W...	.011	.03	.02			
			56	2IR56W...	2IL56W...	.011	.03	.02			
			48	2IR48W...	2IL48W...	.013	.02	.02			
			40	2IR40W...	2IL40W...	.016	.02	.02			
			36	2IR36W...	2IL36W...	.018	.02	.02			
			32	2IR32W...	2IL32W...	.020	.02	.02			
			28	2IR28W...	2IL28W...	.023	.02	.03			
			26	2IR26W...	2IL26W...	.025	.03	.03			
			24	2IR24W...	2IL24W...	.027	.03	.03			
			22	2IR22W...	2IL22W...	.029	.03	.04			
			20	2IR20W...	2IL20W...	.032	.03	.04			
			19	2IR19W...	2IL19W...	.034	.03	.04			
			18	2IR18W...	2IL18W...	.035	.03	.04			
16	2IR16W...	2IL16W...	.040	.04	.04						
14	2IR14W...	2IL14W...	.046	.04	.04						
12	2IR12W...	2IL12W...	.052	.04	.05						
 SCB	1/4" SCB	.43	36	2JIR36W...		.018	.05	.02	-	-	NVR..-2
			32	2JIR32W...		.020	.05	.02			
			28	2JIR28W...		.023	.03	.03			
			24	2JIR24W...		.027	.03	.03			
			20	2JIR20W...		.032	.03	.03			
			19	2JIR19W...		.034	.02	.03			
			18	2JIR18W...		.035	.03	.03			
			16	2JIR16W...		.040	.03	.03			
14	2JIR14W...		.046	.03	.04						
	3/8"	.63	72	3IR72W...	3IL72W...	.009	.03	.02	YI3	YE3	AVR..-3 (LH)
			60	3IR60W...	3IL60W...	.011	.03	.02			
			56	3IR56W...	3IL56W...	.011	.03	.02			
			48	3IR48W...	3IL48W...	.013	.02	.02			
			40	3IR40W...	3IL40W...	.016	.02	.02			
			36	3IR36W...	3IL36W...	.018	.02	.02			
			32	3IR32W...	3IL32W...	.020	.02	.02			
			30	3IR30W...	3IL30W...	.022	.02	.03			

Whitworth - BSW, BSP, BSF, BSB (con't)

Internal

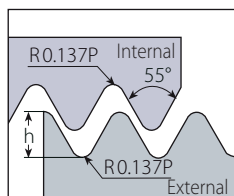

Defined by: B.S.84:1956, DIN 259, ISO228/1:1982
Tolerance class: Medium class A

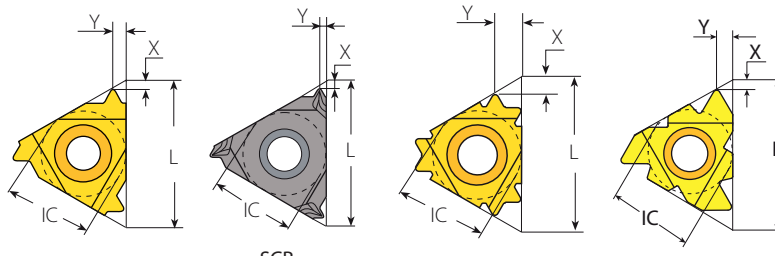





Standard

SCB
Sintered
Chipbreaker

V6

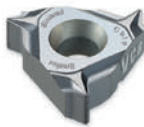
F-Line

Standard

Insert Size		Pitch	Ordering Code		Dimensions inch			Anvil		Toolholder	
IC	L inch	TPI	RH	LH	h min	X	Y	RH	LH		
	3/8"	.63	28	3IR28W...	3IL28W...	.023	.02	.03	YI3	YE3	AVR...-3 (LH)
			26	3IR26W...	3IL26W...	.025	.03	.03			
			24	3IR24W...	3IL24W...	.027	.03	.03			
			22	3IR22W...	3IL22W...	.029	.03	.04			
			20	3IR20W...	3IL20W...	.032	.03	.04			
			19	3IR19W...	3IL19W...	.034	.03	.04			
			18	3IR18W...	3IL18W...	.035	.03	.04			
			16	3IR16W...	3IL16W...	.040	.04	.04			
			14	3IR14W...	3IL14W...	.046	.04	.05			
			12	3IR12W...	3IL12W...	.054	.04	.06			
			11	3IR11W...	3IL11W...	.058	.04	.06			
			10	3IR10W...	3IL10W...	.064	.04	.06			
9	3IR9W...	3IL9W...	.071	.05	.07						
8	3IR8W...	3IL8W...	.080	.05	.06						
 SCB	3/8" SCB	.63	28	3JIR28W...		.023	.03	.03	YI3	-	AVR...-3
			24	3JIR24W...		.027	.03	.03			
			20	3JIR20W...		.032	.03	.03			
			19	3JIR19W...		.034	.02	.02			
			18	3JIR18W...		.035	.03	.03			
			16	3JIR16W...		.040	.03	.03			
			14	3JIR14W...		.046	.05	.06			
			12	3JIR12W...		.054	.05	.06			
11	3JIR11W...		.058	.05	.06						
10	3JIR10W...		.064	.05	.06						
8	3JIR8W...		.080	.05	.06						
 V6	3/8" V6	.63	19	3IR19W-6C...		.034	.07	.09	YI3-6C	-	AVR...-3 NVRC...-3V6
			16	3IR16W-6C...		.040	.06	.10			
			14	3IR14W-6C...		.046	.07	.11			
			12	3IR12W-6C...		.054	.07	.10			
	1/2"	.87	7	4IR7W...	4IL7W...	.095	.06	.09	YI4	YE4	AVR...-4 (LH)
			6	4IR6W...	4IL6W...	.107	.06	.09			
			5	4IR5W...	4IL5W...	.128	.07	.09			
	1/2" F	.91	7	4FIR7W...		.095	.06	.09	YI4F		AVRC...-4F
			6	4FIR6W...		.107	.06	.09			
			5	4FIR5W...		.128	.07	.09			
	5/8"	1.06	4.5	5IR4.5W...	5IL4.5W...	.142	.07	.10	YI5	YE5	AVR...-5 (LH)
			4	5IR4W...	5IL4W...	.160	.08	.11			

F LINE

Whitworth - BSW, BSP, BSF, BSB (con't)

Internal

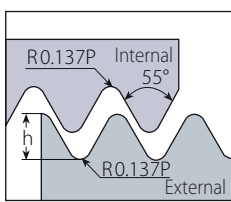

Defined by: B.S.84:1956, DIN 259, ISO228/1:1982
Tolerance class: Medium class A

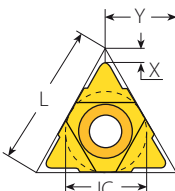

U Style

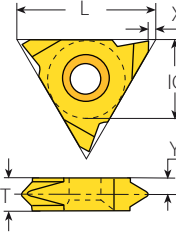

V Style

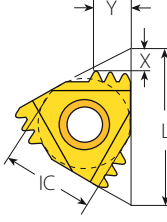

M+ Style

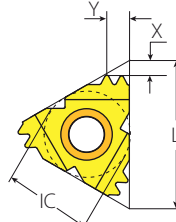

F-Line M+

U Style

Insert Size		Pitch	Ordering Code		Dimensions inch			Anvil		Toolholder
IC	L inch	TPI	RH+LH	h min	X	Y	RH	LH		
1/2"U	.87	4.5	4UEI4.5W...	.142	.09	.43	YI4U	YE4U	AVR...-4U (LH)	
		4	4UEI4W...	.160	.07	.43				
		3.5	4UEI3.5W...	.183	.08	.43				
		3.25	4UEI3.25W...	.197	.08	.43				
5/8"U	1.06	3.5	5UEI3.5W...	.183	.08	.54	YI5U	YE5U	AVR...-5U (LH)	
		3.25	5UEI3.25W...	.197	.08	.54				
		3	5UEI3W...	.213	.09	.54				
		2.75	5UEI2.75W...	.233	.09	.54				

V Style

Insert Size		Pitch	Ordering Code		Dimensions inch					Toolholder
IC	L inch	TPI	RH	LH	h min	X	Y	T		
5/8"V	1.06	4	5VIR4W...	5VIL4W...	.160	.04	.13	.24	NVR...-5V (LH)	
		3	5VIR3W...	5VIL3W...	.213	.04	.17	.31		
		2.5	5VIR2.5W...	5VIL2.5W...	.256	.04	.20	.39		

M+ Style

FLINE

Insert Size		Pitch	Teeth	Ordering Code	Dimensions inch			Anvil		Toolholder
IC	L inch	TPI		RH	h min	X	Y	RH		
3/8"	.63	14	2	3IR14W2M+...	.046	.08	.12	YI3M	AVR...-3	
1/2"	.87	11	2	4IR11W2M+...	.058	.09	.14	YI4M	AVR...-4	
1/2"F	.91	11	2	4FIR11W2M+...	.058	.09	.14	YI4M2F	AVRC... -4MF	

Multiplus

vargus
NEUMO Ehrenberg Group

69

Whitworth - BSW, BSP, BSF, BSB (con't)

Mini-V

Internal

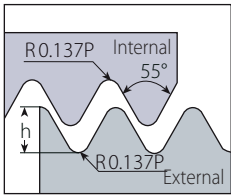

Defined by: B.S.84:1956, DIN 259, ISO228/1:1982
Tolerance class: Medium Class A

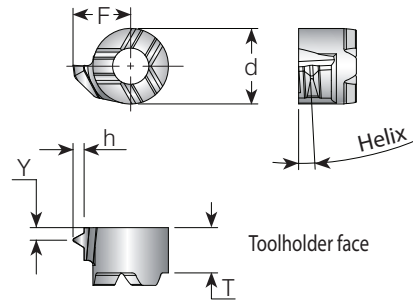

Mini-V



Min. Thread	Insert Style	Pitch	Ordering Code	Dimensions inch						Helix	Toolholder
				TPI	RH	d	T	F	Y		
1/2"x19W	V11	19	V11TH19WR...	.31	.17	.24	.03	.034	2	.V11-...	

Internal

Defined by: B.S.84:1956, DIN 259, ISO228/1:1982
Tolerance class: Medium class A

Mini-3 Standard



Insert Size		Pitch	Ordering Code		Dimensions inch			Min. Bore Dia.	Toolholder
IC mm	L inch	TPI	RH	LH	h min	Y	F	inch	
4.0	.24	26	4.0KIR26W...	4.0KIL26W...	.025	.02	.14	.25	.NVR...-4.0K (LH)
		22	4.0KIR22W...	4.0KIL22W...	.029	.02	.15	.25	
		20	4.0KIR20W...	4.0KIL20W...	.032	.03	.15	.25	
		19	4.0KIR19W...	4.0KIL19W...	.034	.03	.15	.25	
		18	4.0KIR18W...	4.0KIL18W...	.035	.03	.15	.25	
5.0	.31	28	5.0KIR28W...	5.0KIL28W...	.023	.02			.NVR...-5.0K (LH)
		24	5.0KIR24W...	5.0KIL24W...	.027	.02			
		20	5.0KIR20W...	5.0KIL20W...	.032	.03	.19	.31	
		19	5.0KIR19W...	5.0KIL19W...	.034	.03			
		18	5.0KIR18W...	5.0KIL18W...	.035	.03			
6.0	.39	28	6.0KIR28W...	6.0KIL28W...	.023	.03	.19	.38	.NVR...-6.0K (LH)
		19	6.0KIR19W...	6.0KIL19W...	.034	.04	.20	.39	
		14	6.0KIR14W...	6.0KIL14W...	.046	.04	.21	.39	

Mini-3 U Style



Insert Size		Pitch	Ordering Code		Dimensions inch			Min. Bore Dia.	Toolholder
IC mm	L inch	TPI	RH+LH	h min	Y	F	inch		
5.0U	.31	14	5.0KUI14W...	.046		.22		.NVR...-5.0KU (LH)	
		12	5.0KUI12W...	.054	.16	.22	.35		
		11	5.0KUI11W...	.058		.22			

Mini-L



Insert Size		Pitch	Ordering Code		Dimensions inch			Min. Bore Dia.	Toolholder
IC mm	TPI	RH	LH	h min	Y	F	inch		
5.0 L	28	5LKIR28W...	5LKIL28W...	.023	.03	.16	.30	.NVR...-5LK (LH)	
	19	5LKIR19W...	5LKIL19W...	.034	.04	.17	.31		
	14	5LKIR14W...	5LKIL14W...	.046	.04	.18	.31		

Whitworth - BSW, BSP, BSF, BSB (con't)

MINIPRO

Internal

Defined by: B.S.84:1956,
DIN 259, ISO228/1:1982
Tolerance class: Medium class A

RH-Single Ended

RH-Double Ended

Micro - Double Ended

Thread	Insert Dia.	Pitch	Ordering Code		Dimensions inch					Min. Bore Dia.	Toolholder
	d mm	TPI	RH	L1	L	F	Y	h min	inch		
1/16"-28BSP	4.0	28	4.0SIR28W...	.63	1.97	.07	.03	.023	.17	SMC...-4.0	
1/4"-26BSF		26	4.0SIR26W...	.63	1.97	.08	.03	.025	.17		
1/4"-24BSW		24	4.0SIR24W...	.63	1.97	.08	.03	.027	.17		
1/16"-28BSP	6.0	28	6.0SIR28W...	.63	1.97	.10	.03	.023	.24	SMC...-6.0	
5/16"-28BSW		26	6.0SIR26W...	.63	1.97	.10	.03	.025	.24		
5/16"-24BSW		24	6.0SIR24W...	.63	1.97	.10	.03	.027	.24		
5/16"-22BSW		22	6.0SIR22W...	.63	1.97	.10	.04	.029	.24		
3/8"-20BSF		20	6.0SIR20W...	.63	1.97	.10	.04	.032	.24		
1/4"-19BSP		19	6.0SIR19W...	.63	1.97	.10	.04	.034	.24		

Left handed tool supplied by request (Example: 6.0SIL19W...).

Micro - Single Ended

microscope

Thread	Insert Dia.	Pitch	Ordering Code		Dimensions inch							Min. Bore Dia.	Toolholder
	d mm	TPI	RH/LH	Helix°	L1	F	Y	h min	L2 ref*	L ref	D Inch		
1/16"-28BSP	6.0	28	M659TH28WL16R/L...	3.5	.63	.11	.03	.02	.73	1.66	.26	MH...-6.0	
1/4"-19BSP		19	M659TH19WL16R/L...				.04	.03			.45		

* L2 Ref: Repeatability within +/-0.008

BSPT

External

Defined by: B.S. 21:1985
Tolerance class: Standard BSPT

Standard

SCB
Sintered
Chipbreaker

V6

Slim Throat

Standard

	Insert Size		Pitch	Ordering Code		Dimensions inch			Anvil		Toolholder
	IC	L inch	TPI	RH	LH	h min	X	Y	RH	LH	
	1/4"	.43	28	2ER28BSPT...	2EL28BSPT...	.023	.02	.02	-	-	NL...-2 (LH)
			19	2ER19BSPT...	2EL19BSPT...	.034	.03	.04	-	-	
			14	2ER14BSPT...	2EL14BSPT...	.046	.04	.04	-	-	
	3/8"	.63	28	3ER28BSPT...	3EL28BSPT...	.023	.02	.02	YE3	YI3	AL...-3 (LH)
			19	3ER19BSPT...	3EL19BSPT...	.034	.03	.04			
			14	3ER14BSPT...	3EL14BSPT...	.046	.04	.05			
			11	3ER11BSPT...	3EL11BSPT...	.058	.04	.06			
	3/8" SCB	.63	28	3JER28BSPT...		.023	.03	.03	YE3	-	AL...-3
			19	3JER19BSPT...		.034	.03	.03			
			14	3JER14BSPT...		.046	.05	.06			
	3/8" V6	.63	19	3ER19BSPT-6C...		.034	.07	.09	YE3-6C	-	AL...-3
			14	3ER14BSPT-6C...		.046	.07	.11			

Slim Throat

	Insert Size		Pitch	Ordering Code		Dimensions inch				Toolholder
	IC	L inch	TPI	RH	LH	h min	X	Y	T	
	3/8"V	.63	28	3VER28BSPT...	3VEL28BSPT...	.023	.04	.12	.14	NL...-3V (LH)
			19	3VER19BSPT...	3VEL19BSPT...	.034	.04	.11	.14	
			14	3VER14BSPT...	3VEL14BSPT...	.046	.04	.09	.14	
			11	3VER11BSPT...	3VEL11BSPT...	.058	.04	.08	.14	

BSPT (con't)

Internal

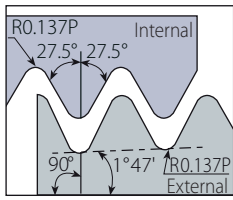

Defined by: B.S. 21:1985
Tolerance class: Standard BSPT

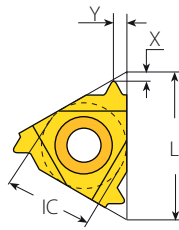

Standard

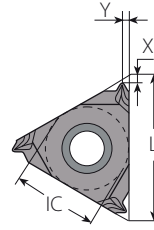

SCB
Sintered
Chipbreaker

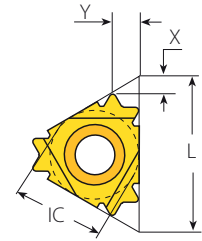

V6

Standard

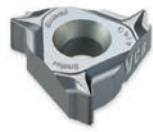

SCB



V6

IC	L inch	TPI	Ordering Code		Dimensions inch			Anvil		Toolholder
			RH	LH	h min	X	Y	RH	LH	
1/4"	.43	28	2IR28BSPT...	2IL28BSPT...	.023	.02	.02	-	-	NVR..-2 (LH)
		19	2IR19BSPT...	2IL19BSPT...	.034	.03	.04	-	-	
		14	2IR14BSPT...	2IL14BSPT...	.046	.04	.04	-	-	
1/4" SCB	.43	28	2JIR28BSPT...		.023	.03	.03	-	-	NVR..-2
		19	2JIR19BSPT...		.034	.03	.03	-	-	
3/8"	.63	28	3IR28BSPT...	3IL28BSPT...	.023	.02	.02	Y13	YE3	AVR..-3 (LH)
		19	3IR19BSPT...	3IL19BSPT...	.034	.03	.04			
		14	3IR14BSPT...	3IL14BSPT...	.046	.04	.05			
		11	3IR11BSPT...	3IL11BSPT...	.058	.04	.06			
3/8" SCB	.63	28	3JIR28BSPT...		.023	.03	.03	Y13	-	AVR..-3
		19	3JIR19BSPT...		.034	.03	.03			
		14	3JIR14BSPT...		.046	.05	.06			
3/8" V6	.63	19	3IR19BSPT-6C...		.034	.07	.09	Y13-6C	-	AVR..-3 NVR...-3V6
		14	3IR14BSPT-6C...		.046	.07	.11			

BSPT

Mini-V

Internal

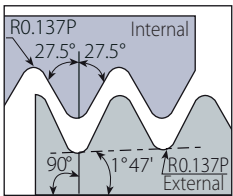

Defined by: B.S.21:1985
Tolerance class: Standard BSPT

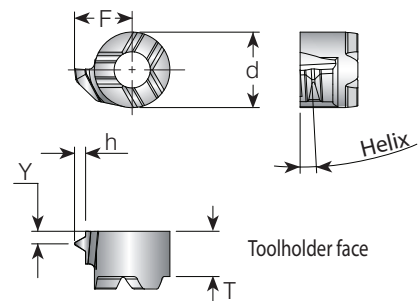

Mini-V



Min. Thread	Insert Style	Pitch	Ordering Code		Dimensions inch					Helix	Toolholder
			TPI	RH	d	T	F	Y	h min		
1/4"-19BSPT	V11	19	V11TH19BSPTR...		.31	.17	.24	.04	.034	2.5	.V11...

BSPT (con't)



Internal

Defined by: B.S. 21:1985
Tolerance class: Standard BSPT

Mini-3 Standard



	Insert Size		Pitch	Ordering Code		Dimensions inch			Min. Bore Dia.	Toolholder
	IC mm	L inch	TPI	RH	LH	h min	Y	F	inch	
	4.0	.24	28	4.0KIR28BSPT...	4.0KIL28BSPT...	.023	.02	.14	.25	.NVR...-4.0K (LH)
			28	5.0KIR28BSPT...	5.0KIL28BSPT...	.023	.02			
	19	5.0KIR19BSPT...	5.0KIL19BSPT...	.034	.03	.19	.31	.NVR...-5.0K (LH)		
6.0	.39	28	6.0KIR28BSPT...	6.0KIL28BSPT...	.023	.02	.19	.38	.NVR...-6.0K (LH)	
		19	6.0KIR19BSPT...	6.0KIL19BSPT...	.034	.04	.20	.39		
		14	6.0KIR14BSPT...	6.0KIL14BSPT...	.046	.05	.21	.39		

Mini-L



	Insert Size		Pitch	Ordering Code		Dimensions inch			Min. Bore Dia.	Toolholder
	IC mm	TPI	TPI	RH	LH	h min	Y	F	inch	
5.0L			28	5LKIR28BSPT...	5LKIL28BSPT...	.023	.02	.16	.30	.NVR...-5LK (LH)
			19	5LKIR19BSPT...	5LKIL19BSPT...	.034	.04	.17	.31	
			14	5LKIR14BSPT...	5LKIL14BSPT...	.046	.05	.18	.31	

NPT

External

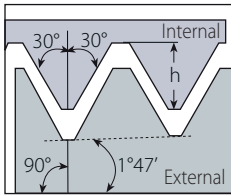

Defined by: USAS B2.1:1968
Tolerance class: Standard NPT

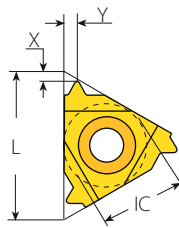

Standard

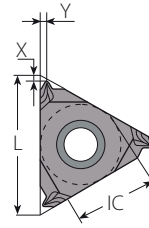

SCB
Sintered
Chipbreaker

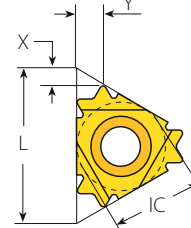

V6

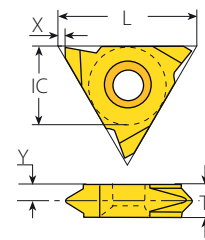

Slim Throat

Standard

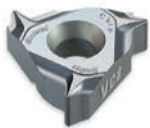

SCB



V6

Insert Size		Pitch	Ordering Code		Dimensions inch			Anvil		Toolholder
IC	L inch	TPI	RH	LH	h min	X	Y	RH	LH	
1/4"	.43	27	2ER27NPT...	2EL27NPT...	.026	.03	.03	-	-	NL...-2 (LH)
		18	2ER18NPT...	2EL18NPT...	.040	.03	.04			
		14	2ER14NPT...	2EL14NPT...	.052	.03	.04			
3/8"	.63	27	3ER27NPT...	3EL27NPT...	.026	.03	.03	YE3	YI3	AL...-3 (LH)
		18	3ER18NPT...	3EL18NPT...	.040	.03	.04			
		14	3ER14NPT...	3EL14NPT...	.052	.04	.05			
		11.5	3ER11.5NPT...	3EL11.5NPT...	.065	.04	.06			
3/8" SCB	.63	27	3JER27NPT...		.026	.02	.03	YE3	-	AL...-3
		18	3JER18NPT...		.040	.02	.03			
		14	3JER14NPT...		.052	.04	.06			
		11.5	3JER11.5NPT...		.065	.04	.06			
3/8" V6	.63	14	3ER14NPT-6C...		.052	.07	.12	YE3-6C	-	AL...-3

Slim Throat



Insert Size		Pitch	Ordering Code		Dimensions inch				Toolholder
IC	L inch	TPI	RH	LH	h min	X	Y	T	
1/4"V	.43	27	2VER27NPT...	2VEL27NPT...	.026	.03	.08	.13	NL...-2V (LH)
		18	2VER18NPT...	2VEL18NPT...	.040	.03	.07	.13	
		14	2VER14NPT...	2VEL14NPT...	.052	.03	.07	.13	
		11.5	2VER11.5NPT...	2VEL11.5NPT...	.065	.03	.08	.13	
3/8"V	.63	27	3VER27NPT...	3VEL27NPT...	.026	.04	.11	.14	NL...-3V (LH)
		18	3VER18NPT...	3VEL18NPT...	.040	.04	.10	.14	
		11.5	3VER11.5NPT...	3VEL11.5 NPT...	.065	.04	.08	.14	

NPT (con't)

External

Defined by: USAS B2.1:1968
Tolerance class: Standard NPT

RS/LS

Varied range of threading standards for machining between shoulders and close to spindle.

VG-Cut



Pocket Size	Ordering Code	Dimensions inch				No. of Passes	Helix	Min. Thread Diameter	Toolholder
	RH	W ref	Pitch	TPI	h min	Y	L ref	Deg	Monoblock
3	VGD3.0NPT18RH-RS/LS...		18		.040	.05	7 - 12		1/4"-18NPT
3	VGD3.0NPT14RH-RS/LS...	.12	14		.052	.06	0.86	8 - 14	1/2"-14NPT
3	VGD3.0NPT11.5RH-RS/LS...		12		.065	.06		9 - 15	1"-11.5NPT

LH Helix threads available upon request.

NPT (con't)

External

Defined by: USAS B2.1:1968
Tolerance class: Standard NPT

M+ Style

F-Line M+

Z+ Style

M+ Style



FLINE

Insert Size		Pitch	Teeth	Ordering Code	Dimensions inch			Anvil	
IC	L inch	TPI		RH	h min	X	Y	RH	Toolholder
3/8"	.63	14	2	3ER14NPT2M+...	.052	.08	.12	YE3M	AL..-3
1/2"	.87	11.5	2	4ER11.5NPT2M+...	.065	.09	.13	YE4M	AL..-4
1/2"	.91	11.5	2	4FER11.5NPT2M+...	.065	.09	.13	YE4M2F	AL..-4MF
5/8"	1.06	11.5	3	5ER11.5NPT3M+...	.065	.14	.22	YE5M	AL..-5M
		8	2	5ER8NPT2M+...	.095	.12	.19		

Multiplus

Z+ Style



Insert Size		Pitch	Teeth	Ordering Code	Dimensions inch			Anvil	
IC	L inch	TPI		RH	h min	X	Y	RH	Toolholder
1/2"	.87	11.5	2	4ER11.5NPT2Z+...	.065	.11	.39	YE4Z	AL..-4Z
		8	2	4ER8NPT2Z+...	.095	.13	.38		

Multiplus

NPT (con't)

Internal

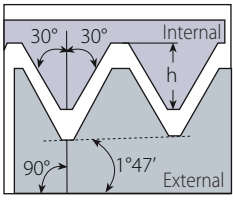

Defined by: USAS B2.1:1968
Tolerance class: Standard NPT

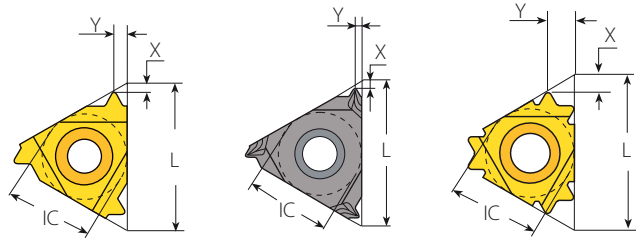

Standard

SCB
Sintered
Chipbreaker

V6

Standard



SCB



V6

Insert Size		Pitch	Ordering Code		Dimensions inch			Anvil		Toolholder
IC	L inch	TPI	RH	LH	h min	X	Y	RH	LH	
1/4"	.43	27	2IR27NPT...	2IL27NPT...	.026	.03	.03	-	-	NVR..-2 (LH)
		18	2IR18NPT...	2IL18NPT...	.040	.03	.04			
		14	2IR14NPT...	2IL14NPT...	.052	.03	.04			
1/4" SCB	.43	27	2JIR27NPT...		.026	.02	.03	-	-	NVR..-2
		18	2JIR18NPT...		.040	.02	.03			
3/8"	.63	27	3IR27NPT...	3IL27NPT...	.026	.03	.03	Y13	YE3	AVR..-3 (LH)
		18	3IR18NPT...	3IL18NPT...	.040	.03	.04			
		14	3IR14NPT...	3IL14NPT...	.052	.04	.05			
		11.5	3IR11.5NPT...	3IL11.5NPT...	.065	.04	.06			
3/8" SCB	.63	8	3IR8NPT...	3IL8NPT...	.095	.05	.07	Y13	-	AVR..-3
		27	3JIR27NPT...		.026	.02	.03			
		18	3JIR18NPT...		.040	.02	.03			
		14	3JIR14NPT...		.052	.04	.06			
3/8" V6	.63	14	3IR14NPT-6C...		.052	.07	.11	Y13-6C	-	AVR..-3 NVRC...-3V6

NPT (con't)

Internal

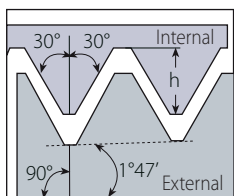

Defined by: USAS B2.1:1968
Tolerance class: Standard NPT

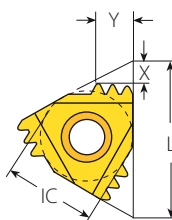

M+ Style

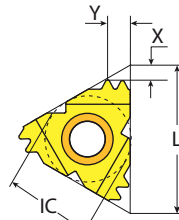

F-Line M+

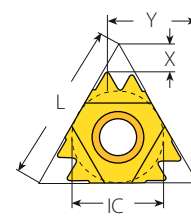

Z+ Style

M+ Style



F LINE

Insert Size		Pitch	Teeth	Ordering Code	Dimensions inch			Anvil	
IC	L inch	TPI		RH	h min	X	Y	RH	Toolholder
3/8"	.63	14	2	3IR14NPT2M+...	.052	.08	.12	YI3M	AVR...-3
1/2"	.87	11.5	2	4IR11.5NPT2M+...	.065	.09	.13	YI4M	AVR...-4
1/2"F	.91	11.5	2	4FIR11.5NPT2M+...	.065	.09	.13	YI4M2F	AVRC...-4MF
5/8"	1.06	11.5	3	5IR11.5NPT3M+...	.065	.14	.22	YI5M	AVR...-5M
		8	2	5IR8NPT2M+...	.095	.12	.19		

Z+ Style



Insert Size		Pitch	Teeth	Ordering Code	Dimensions inch			Anvil	
IC	L inch	TPI		RH	h min	X	Y	RH	Toolholder
1/2"	.87	11.5	2	4IR11.5NPT2Z+...	.065	.11	.39	YI4Z	AVR...-4Z
		8	2	4IR8NPT2Z+...	.095	.13	.38		

NPT (con't)

Mini-V

Internal

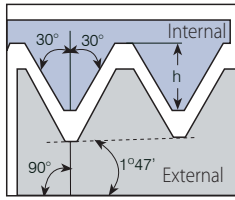

Defined by: USAS B2.1:1968
Tolerance class: Standard NPT

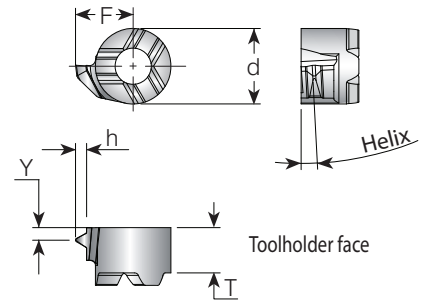

Mini-V



Min. Thread	Insert Style	Pitch	Ordering Code		Dimensions inch					Helix	Toolholder
			TPI	RH	d	T	F	Y	h min		
1/8"-27NPT	V08	27	V08TH27NPTR...		.24	.15	.17	.02	.025	2	.V08-...
1/4"-18NPT		18	V08TH18NPTR...				.19	.04	.039	2	

NPT

MINIPRO

Internal

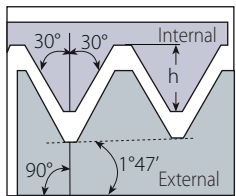

Defined by: USAS B2.1:1968
Tolerance class: Standard NPT

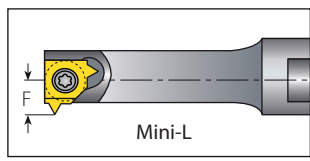
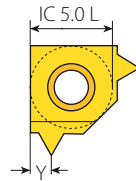
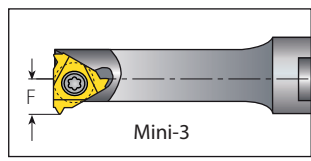
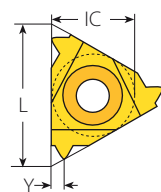

Mini-3 Standard



Insert Size	Pitch	Ordering Code			Dimensions inch			Min. Bore Dia.	Toolholder
		IC mm	L inch	TPI	RH	LH	h min		
4.0	.24	27	4.0KIR27NPT...	4.0KIL27NPT...	.026	.02	.15	.25	.NVR...-4.0K (LH)
			5.0KIR27NPT...	5.0KIL27NPT...	.026	.02			
5.0	.31	18	5.0KIR18NPT...	5.0KIL18NPT...	.040	.03	.19	.31	.NVR...-5.0K (LH)
		27	6.0KIR27NPT...	6.0KIL27NPT...	.026	.03	.21		
6.0	.39	18	6.0KIR18NPT...	6.0KIL18NPT...	.040	.04	.21	.39	.NVR...-6.0K (LH)
		14	6.0KIR14NPT...	6.0KIL14NPT...	.052	.04	.21		

Mini-L



Insert Size	Pitch	Ordering Code			Dimensions inch			Min. Bore Dia.	Toolholder
		IC mm	TPI	RH	LH	h min	Y		
5.0L	27	5LKIR27NPT...	5LKIL27NPT...	.026	.03	.18	.315	.NVR...-5LK (LH)	
	18	5LKIR18NPT...	5LKIL18NPT...	.040	.04	.18			
	14	5LKIR14NPT...	5LKIL14NPT...	.052	.04	.18			

NPT (con't)

MINIPRO

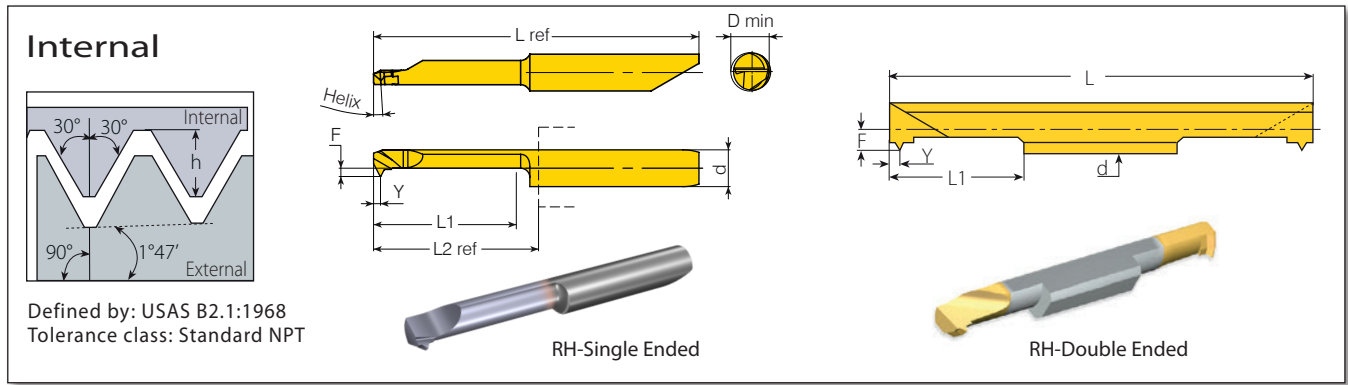

Defined by: USAS B2.1:1968
Tolerance class: Standard NPT

RH-Single Ended

RH-Double Ended

Micro - Double Ended

Thread	Insert Dia. d mm	Pitch TPI	Ordering Code RH	Dimensions inch					Min. Bore Dia. mm	Toolholder
				L1	L	F	Y	h min		
1/16"-27NPT	6.0	27	6.0SIR27NPT...	.63	1.97	.10	.04	.026	.23	SMC...-6.0
1/4"-18NPT		18	6.0SIR18NPT...	.63	1.97	.10	.03	.040	.24	

Left handed tool supplied by request (Example: 6.0SIL18NPT...).

Micro - Single Ended

microscope

Thread	Insert Dia. d mm	Pitch TPI	Ordering Code RH/LH	Helix°	L1	Dimensions inch			L2 ref*	L ref	Min. Bore Dia. D mm	Toolholder			
						F	Y	h min							
1/16"-27NPT	6.0	27	M659TH27NPTL16R/L...	3.5	.63	.11	.03	.026	.73	1.66	.24	MH...-6.0			
1/4"-18NPT		18	M659TH18NPTL16R/L...										.04	.040	.67
1/2"-14NPT		14	M659TH14NPTL16R/L...										.04	.052	

* L2 Ref: Repeatability within +/- .0008

ANPT

External / Internal

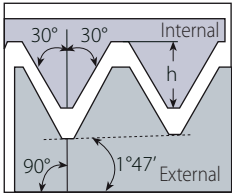

Defined by: MIL-P-7105B
Tolerance class: Standard ANPT

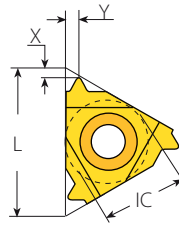

External Standard

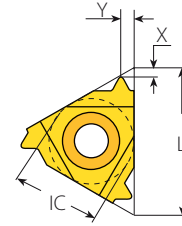

Internal Standard

Standard - External



Insert Size		Pitch	Ordering Code		Dimensions inch			Anvil		Toolholder
IC	L inch	TPI	RH	LH	h min	X	Y	RH	LH	
3/8"	.63	18	3ER18ANPT...	3EL18ANPT...	.043	.03	.04	YE3	YI3	AL...-3 (LH)
		14	3ER14ANPT...	3EL14ANPT...	.055	.03	.04			

Standard - Internal



Insert Size		Pitch	Ordering Code		Dimensions inch			Anvil		Toolholder
IC	L inch	TPI	RH	LH	h min	X	Y	RH	LH	
1/4"	.43	18	2IR18ANPT...	2IL18ANPT...	.043	.03	.04	-	-	NVR...-2 (LH)
3/8"	.63	14	3IR14ANPT...	3IL14ANPT...	.055	.03	.04	YI3	YE3	AVR...-3 (LH)

NPTF

External

Defined by: ANSI B1.20.3-1976
Tolerance class: Standard NPTF

Standard

**SCB
Sintered
Chipbreaker**

M+ Style

Standard



Insert Size		Pitch	Ordering Code		Dimensions inch			Anvil		Toolholder
IC	L inch	TPI	RH	LH	h min	X	Y	RH	LH	
1/4"	.43	27	2ER27NPTF...	2EL27NPTF...	.025	.03	.03	-	-	NL..-2 (LH)
		18	2ER18NPTF...	2EL18NPTF...	.039	.03	.04			
		14	2ER14NPTF...	2EL14NPTF...	.053	.03	.04			
3/8"	.63	27	3ER27NPTF...	3EL27NPTF...	.025	.03	.03	YE3	YI3	AL..-3 (LH)
		18	3ER18NPTF...	3EL18NPTF...	.039	.03	.04			
		14	3ER14NPTF...	3EL14NPTF...	.053	.04	.05			
		11.5	3ER11.5NPTF...	3EL11.5NPTF...	.064	.04	.06			
3/8" SCB	.63	27	3JER27NPTF...		.025	.03	.03	YE3	-	AL..-3
		18	3JER18NPTF...		.039	.02	.03			
		14	3JER14NPTF...		.053	.04	.06			
		11.5	3JER11.5NPTF...		.064	.04	.06			
		8	3JER8NPTF...		.094	.04	.06			

M+ Style



Insert Size		Pitch	Teeth	Ordering Code	Dimensions inch			Anvil		Toolholder
IC	L inch	TPI		RH	h min	X	Y	RH		
3/8"	.63	14	2	3ER14NPTF2M+...		.053	.08	.12	YE3M	AL...-3



NPTF (con't)

Internal

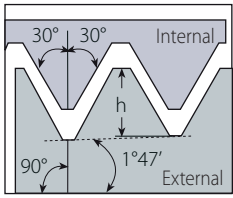

Defined by: ANSI B1.20.3-1976
Tolerance class: Standard NPTF

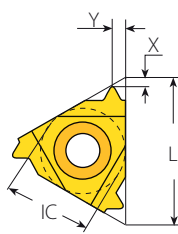

Standard

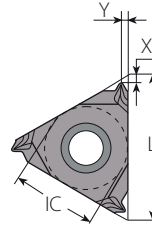

SCB
Sintered
Chipbreaker

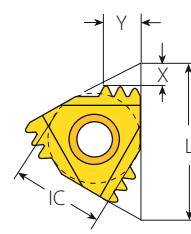

M+ Style

Standard



SCB

Insert Size		Pitch	Ordering Code		Dimensions inch			Anvil		Toolholder
IC	L inch	TPI	RH	LH	h min	X	Y	RH	LH	
1/4"	.43	27	2IR27NPTF...	2IL27NPTF...	.025	.03	.03	-	-	NVR..-2 (LH)
		18	2IR18NPTF...	2IL18NPTF...	.039	.03	.04			
		14	2IR14NPTF...	2IL14NPTF...	.053	.03	.04			
1/4" SCB	.43	27	2JIR27NPTF...		.025	.03	.03	-	-	NVR..-2
		18	2JIR18NPTF...		.039	.02	.03			
3/8"	.63	27	3IR27NPTF...	3IL27NPTF...	.025	.03	.03	YI3	YE3	AVR..-3 (LH)
		18	3IR18NPTF...	3IL18NPTF...	.039	.03	.04			
		14	3IR14NPTF...	3IL14NPTF...	.053	.04	.05			
		11.5	3IR11.5NPTF...	3IL11.5NPTF...	.064	.04	.06			
3/8" SCB	.63	27	3JIR27NPTF...		.025	.03	.03	YI3	-	AVR..-3
		18	3JIR18NPTF...		.039	.02	.03			
		14	3JIR14NPTF...		.053	.04	.06			
		11.5	3JIR11.5NPTF...		.064	.04	.06			
		8	3JIR8NPTF...		.094	.04	.06			

M+ Style



Insert Size		Pitch	Teeth	Ordering Code	Dimensions inch			Anvil		Toolholder
IC	L inch	TPI		RH	h min	X	Y	RH		
3/8"	.63	14	2	3IR14NPTF2M+...	.053	.08	.12	YI3M	AVR..-3	

NPTF (con't)

Mini-V

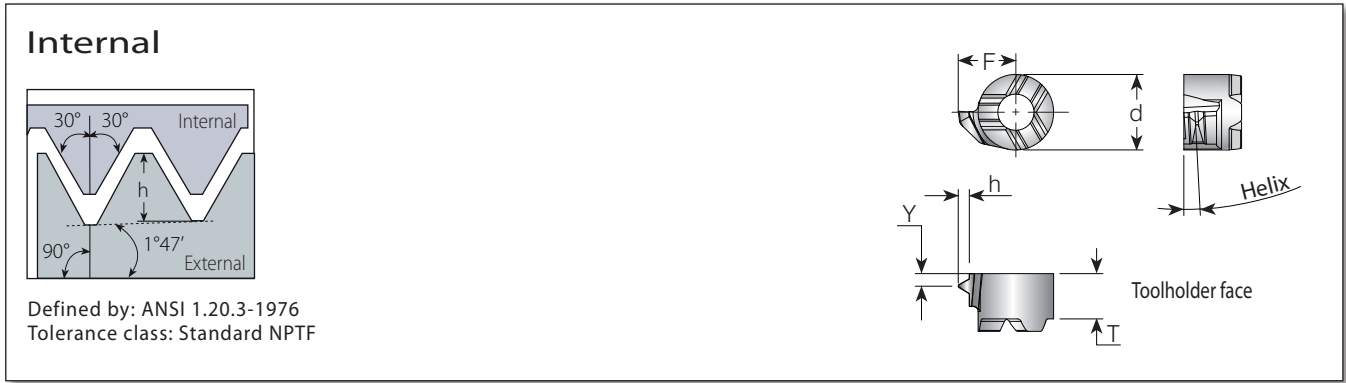

Mini-V



Min. Thread	Insert Style	Pitch	Ordering Code	Dimensions inch					Helix Deg.	Toolholder
				d	T	F	Y	h min		
1/4"-18NPTF	V08	18	V08TH18NPTFR...	.24	.15	.18	.04	.04	2.0	.V08-...

NPTF (con't)

Internal

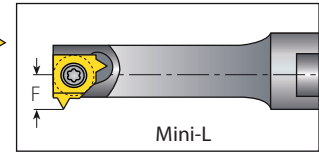
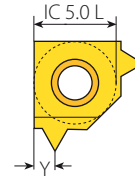
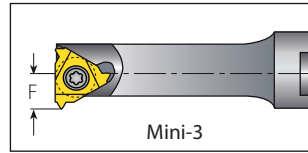
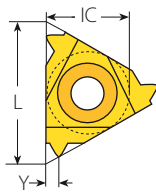
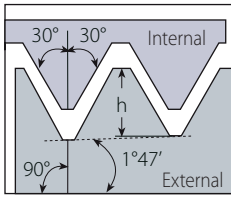

Defined by: ANSI B1.20.3-1976
Tolerance class: Standard NPTF

Mini-3 Standard



Insert Size	Pitch		Ordering Code		Dimensions inch			Min. Bore Dia.	Toolholder
	IC mm	L inch	TPI	RH	LH	h min	Y	F	
4.0	.24	27	4.0KIR27NPTF...	4.0KIL27NPTF...	.025	.02	.14	.25	.NVR...-4.0K (LH)
		18	5.0KIR18NPTF...	5.0KIL18NPTF...	.039	.03	.19	.31	.NVRC...-5.0K (LH)
6.0	.39	27	6.0KIR27NPTF...	6.0KIL27NPTF...	.025	.03	.21	.39	.NVR...-6.0K (LH)
		18	6.0KIR18NPTF...	6.0KIL18NPTF...	.039	.04	.21		
		14	6.0KIR14NPTF...	6.0KIL14NPTF...	.053	.04	.21		

Mini-L



Insert Size	Pitch		Ordering Code		Dimensions inch			Min. Bore Dia.	Toolholder
	IC mm	TPI	RH	LH	h min	Y	F	inch	
5.0L		27	5LKIR27NPTF...	5LKIL27NPTF...	.025	.03	.18	.31	.NVR...-5LK (LH)
		18	5LKIR18NPTF...	5LKIL18NPTF...	.039	.04	.18		
		14	5LKIR14NPTF...	5LKIL14NPTF...	.053	.04	.18		

NPTF

Internal

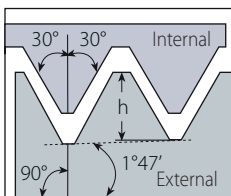

Defined by: ANSI B1.20.3-1976
Tolerance class: Standard NPTF

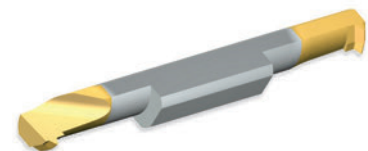
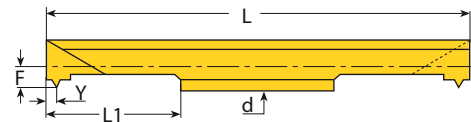

RH-Double Ended

Micro - Double Ended

Thread	Insert Dia.	Pitch	Ordering Code		Dimensions inch					Min. Bore Dia.	Toolholder
	d mm	TPI	RH	LH	L1	L	F	Y	h min	inch	
1/16"-27NPTF	6.0	27	6.0SIR27NPTF...		.63	1.97	.10	.03	.025	.24	SMC...-6.0
1/4"-18NPTF		18	6.0SIR18NPTF...		.63	1.97	.10	.04	.039		

Left handed tool supplied by request (Example: 6.0SIL18NPTF...).

NPS

External / Internal

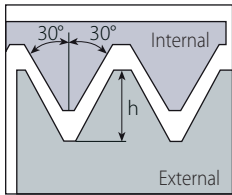

Defined by: USA NBS H28 (1957)
Tolerance class: Standard NPS

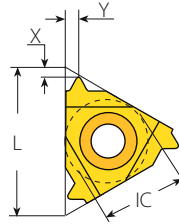

External Standard

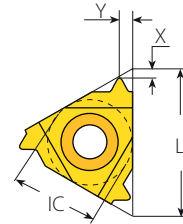

Internal Standard

Standard - External



Insert Size		Pitch	Ordering Code		Dimensions inch			Anvil		Toolholder
IC	L inch	TPI	RH	LH	h min	X	Y	RH	LH	
3/8"	.63	24	3ER24NPS...	3EL24NPS...	.031	.03	.03	YE3	YI3	AL...-3 (LH)
		16	3ER16NPS...	3EL16NPS...	.048	.03	.04			
		14	3ER14NPS...	3EL14NPS...	.052	.04	.05			
		12	3ER12NPS...	3EL12NPS...	.064	.04	.06			
		11.5	3ER11.5NPS...	3EL11.5NPS...	.067	.04	.06			
1/2"	.87	9	3ER9NPS...	3EL9NPS...	.087	.05	.06	YE4	YI4	AL...-4 (LH)
		8	4ER8NPS...	4EL8NPS...	.097	.05	.07			
		7	4ER7NPS...	4EL7NPS...	.111	.06	.09			
5/8"	1.06	6	4ER6NPS...	4EL6NPS...	.130	.06	.09	YE5	YI5	AL...-5 (LH)
		5	5ER5NPS...	5EL5NPS...	.157	.07	.11			

Standard - Internal



Insert Size		Pitch	Ordering Code		Dimensions inch			Anvil		Toolholder
IC	L inch	TPI	RH	LH	h min	X	Y	RH	LH	
3/8"	.63	24	3IR24NPS...	3IL24NPS...	.031	.03	.03	YI3	YE3	AVR...-3 (LH)
		14	3IR14NPS...	3IL14NPS...	.052	.04	.05			
		12	3IR12NPS...	3IL12NPS...	.064	.04	.06			
		11.5	3IR11.5NPS...	3IL11.5NPS...	.067	.04	.06			
1/2"	.87	9	3IR9NPS...	3IL9NPS...	.087	.05	.06	YI4	YE4	AVR...-4 (LH)
		8	4IR8NPS...	4IL8NPS...	.097	.05	.07			
		7	4IR7NPS...	4IL7NPS...	.111	.06	.09			
5/8"	1.06	6	4IR6NPS...	4IL6NPS...	.130	.06	.09	YI5	YE5	AVR...-5 (LH)
		5	5IR5NPS...	5IL5NPS...	.157	.07	.11			

Round (DIN 405)

External

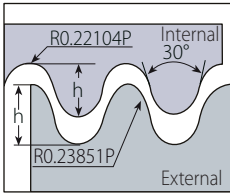

Defined by: DIN 405
Tolerance class: 7h/7H

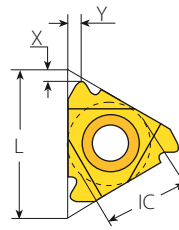

Standard

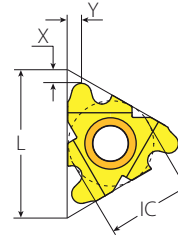

F-Line

Standard



FLINE

Insert Size		Pitch	Ordering Code		Dimensions inch			Anvil		Toolholder
IC	L inch	TPI	RH	LH	h min	X	Y	RH	LH	
3/8"	.63	10	3ER10RD...	3EL10RD...	.050	.04	.05	YE3	YI3	AL...-3 (LH)
		8	3ER8RD...	3EL8RD...	.063	.06	.05			
		6	3ER6RD...	3EL6RD...	.083	.06	.07			
1/2"	.87	6	4ER6RD...	4EL6RD...	.083	.06	.07	YE4	YI4	AL...-4 (LH)
		4	4ER4RD...	4EL4RD...	.125	.09	.09			
1/2"F	.91	6	4FER6RD...		.083	.06	.07	YE4F		AL...-4F
		4	4FER4RD...		.125	.09	.09			
5/8"	1.06	4	5ER4RD...	5EL4RD...	.125	.09	.09	YE5	YI5	AL...-5 (LH)

Internal

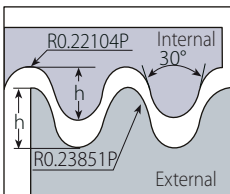

Defined by: DIN 405
Tolerance class: 7h/7H

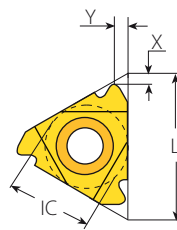

Standard

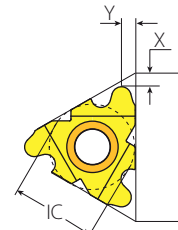

F-Line

Standard



FLINE

Insert Size		Pitch	Ordering Code		Dimensions inch			Anvil		Toolholder
IC	L inch	TPI	RH	LH	h min	X	Y	RH	LH	
3/8"	.63	10	3IR10RD...	3IL10RD...	.050	.04	.05	YI3	YE3	AVR...-3 (LH)
		8	3IR8RD...	3IL8RD...	.063	.06	.06			
		6	3IR6RD...	3IL6RD...	.083	.06	.06			
1/2"	.87	6	4IR6RD...	4IL6RD...	.083	.06	.07	YI4	YE4	AVR...-4 (LH)
		4	4IR4RD...	4IL4RD...	.125	.09	.09			
1/2"F	.91	6	4FIR6RD...		.083	.06	.07	YI4F		AVRC...-4F
		4	4FIR4RD...		.125	.09	.09			
5/8"	1.06	4	5IR4RD...	5IL4RD...	.125	.09	.09	YI5	YE5	AVR...-5 (LH)

Round (DIN 20400)

External

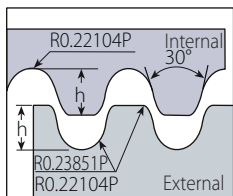

Defined by: DIN 20400
Tolerance class: Standard

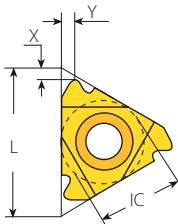

Standard

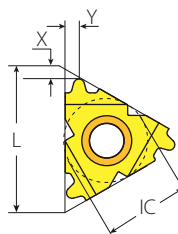

F-Line

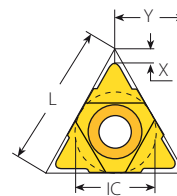

U Style

Standard



F-LINE

Insert Size		Pitch	Ordering Code		Dimensions inch			Anvil		Toolholder
IC	L inch	mm	RH	LH	h min	X	Y	RH	LH	
1/2"	.87	3.0	4ER3.0RD20400...	4EL3.0RD20400...	.065	.05	.07	YE4	YI4	AL...-4 (LH)
		4.0	4ER4.0RD20400...	4EL4.0RD20400...	.087	.06	.09			
		5.0	4ER5.0RD20400...	4EL5.0RD20400...	.108	.06	.07			
		6.0	4ER6.0RD20400...	4EL6.0RD20400...	.130	.07	.08			
1/2"F	.91	3.0	4FER3.0RD20400...		.065	.05	.07	YE4F		AL...-4F
		4.0	4FER4.0RD20400...		.087	.06	.09			
		5.0	4FER5.0RD20400...		.108	.06	.07			
		6.0	4FER6.0RD20400...		.130	.07	.08			

U Style



Insert Size		Pitch	Ordering Code	Dimensions inch			Anvil		Toolholder	
IC	L inch	mm	RH+LH	h min	X	Y	RH	LH		
5/8"U	1.06	8.0	5UEI8.0RD20400...		.173	.11	.53	YE5U	YI5U	AL...-5U (LH)

Round (DIN 20400) (con't)

MEGALINE

External

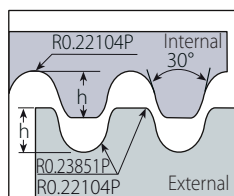

Defined by: DIN 20400
Tolerance class: Standard

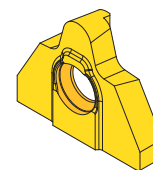
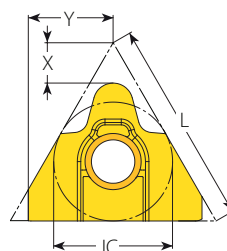

Mega Line

External



Insert Size	Pitch	Ordering Code	EDP No.	Dimensions inch			Number of Passes			
				IC	L inch	mm	RH	VKX	h min	X
5/8" MG	1.06	10.0	5MGER10.0RD20400...	42517	.217	.16			78	36
		12.0	5MGER12.0RD20400...	42518	.260	.21	.44		93	43
		16.0	5MGER16.0RD20400...	42519	.346	.19			124	58

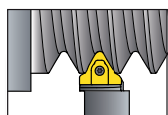

External Toolholders for Round (DIN 20400)

MEGALINE

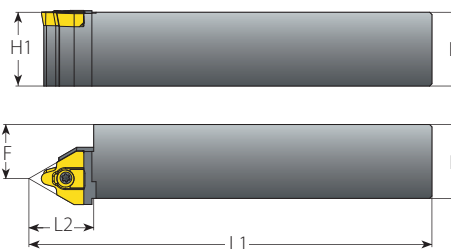
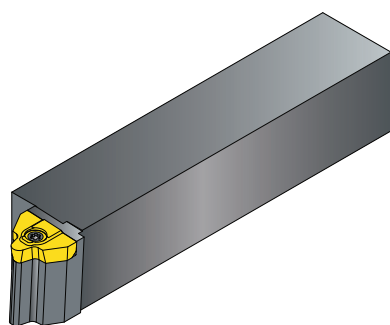

External

Spare Parts

Insert	Ordering Code	EDP No.	Dimensions inch			Thread Diameter Range (Min.-Max.)	Insert Screw	Torx Key
			RH	H=B=H1	F			
5MGER10.0RD20400...	NL100-5MG10RD	66251	1.00	.65	6.1	(RD132-170)x10	S5MG	K6T
	NL125-5MG10RD	66253	1.25	.93	6.9			
	NL150-5MG10RD	66256	1.50	1.24	8.1			
5MGER12.0RD20400...	NL100-5MG12RD	66257	1.00	.65	6.1	(RD180-224)x12	S5MG	K6T
	NL125-5MG12RD	66258	1.25	.93	6.9			
	NL150-5MG12RD	66259	1.50	1.24	8.1			
5MGER16.0RD20400...	NL100-5MG16RD	66262	1.00	.65	6.1	(RD236-300)x16	S5MG	K6T
	NL125-5MG16RD	66263	1.25	.93	6.9			
	NL150-5MG16RD	66266	1.50	1.24	8.1			

Recommended thread infeed method for Mega Line: Flank or Modified Flank 1°.

Round (DIN 20400) (con't)

Internal

Defined by: DIN 20400
Tolerance class: Standard

Standard

F-Line

U Style

Standard

FLINE

Insert Size		Pitch	Ordering Code		Dimensions inch			Anvil		Toolholder
IC	L inch	mm	RH	LH	h min	X	Y	RH	LH	
1/2"	.87	3.0	4IR3.0RD20400...	4IL3.0RD20400...	.065	.05	.07	YI4	YE4	AVR..-4 (LH)
		4.0	4IR4.0RD20400...	4IL4.0RD20400...	.087	.06	.09			
		5.0	4IR5.0RD20400...	4IL5.0RD20400...	.108	.06	.07			
		6.0	4IR6.0RD20400...	4IL6.0RD20400...	.130	.07	.08			
1/2"F	.91	3.0	4FIR3.0RD20400...		.065	.05	.07	YI4F		AVRC...-4F
		4.0	4FIR4.0RD20400...		.087	.06	.09			
		5.0	4FIR5.0RD20400...		.108	.06	.07			
		6.0	4FIR6.0RD20400...		.130	.07	.08			

U Style

Insert Size		Pitch	Ordering Code	Dimensions inch			Anvil		Toolholder	
IC	L inch	mm	RH+LH	h min	X	Y	RH	LH		
5/8"U	1.06	8.0	5UEI8.0RD20400...		.173	.11	.53	YI5U	YE5U	AVR..-5U (LH)

vargus
NEUMO Ehrenberg Group

91

Round (DIN 20400) (con't)

MEGALINE

Internal

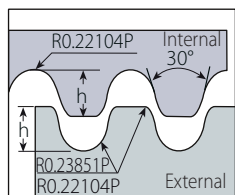

Defined by: DIN 20400
Tolerance class: Standard

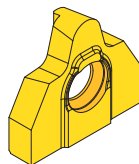

Mega Line

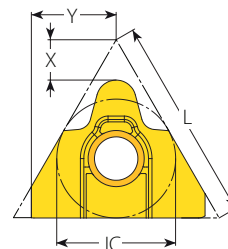

Internal



Insert Size	Pitch		Ordering Code	EDP No.	Dimensions inch			Number of Passes		
	IC	L inch			mm	RH	VKX	h min	X	Y
5/8" MG	1.06	10.0	5MGIR10.0RD20400...	42514	.217	.16			78	36
		12.0	5MGIR12.0RD20400...	42515	.260	.21	.41		93	43
		16.0	5MGIR16.0RD20400...	42516	.346	.19			124	58

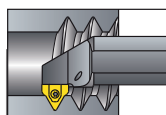

Internal Toolholders for Round (DIN 20400) MEGALINE

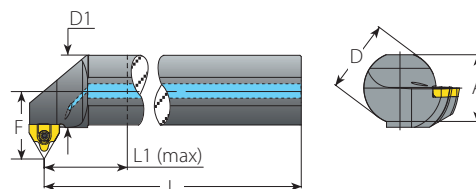
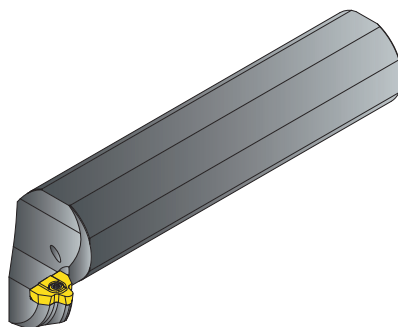

Internal

Insert	Ordering Code	EDP No.	Dimensions inch						Min. Bore Dia.	Thread Diameter Range (Min.-Max.)		Spare Parts	
			A	L	L1 (max)	D	D1	F		inch	Short Chip Material	Long Chip Material	Insert Screw
5MGIR10.0RD20400...	NVRC150-5MG10RD	66276	1.42	9.15	4	1.5	1.49	1.63	4.8	(RD132-170)x10	(RD132-170)x10	S5MG	K6T
	NVRC200-5MG10RD	66278	1.81	10.15	5	2.0	1.99	1.83					
	NVRC250-5MG10RD	66288	2.28	11.10	6	2.5	2.49	2.03					
5MGIR12.0RD20400...	NVRC150-5MG12RD	66289	1.42	9.15	4	1.5	1.49	1.63	6.61	(RD180-224)x12	(RD180-224)x12	S5MG	K6T
	NVRC200-5MG12RD	66293	1.81	10.15	5	2.0	1.99	1.83					
	NVRC250-5MG12RD	66318	2.28	11.10	6	2.5	2.49	2.03					
5MGIR16.0RD20400...	NVRC150-5MG16RD	66321	1.42	9.15	4	1.5	1.49	1.63	8.66	(RD236-300)x16	(RD236-300)x16	S5MG	K6T
	NVRC200-5MG16RD	66339	1.81	10.15	5	2.0	1.99	1.83					
	NVRC250-5MG16RD	66340	2.28	11.10	6	2.5	2.49	2.03					

Recommended thread infeed method for Mega Line: Flank or Modified Flank 1°.

Trapez

External

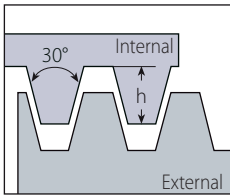

Defined by: DIN 103
Tolerance class: 7e/7H

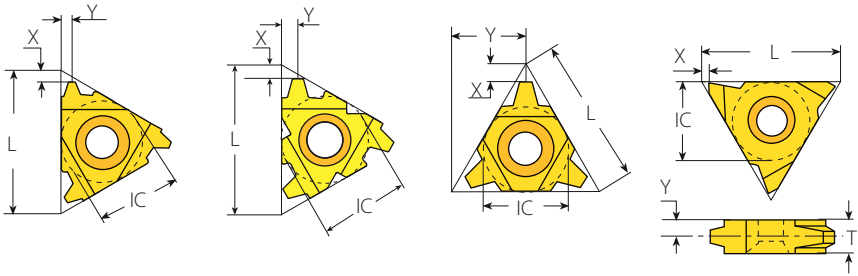

Standard
F-Line
U Style
V Style

Standard



Insert Size		Pitch	Ordering Code		Dimensions inch			Anvil		Toolholder
IC	L inch	mm	RH	LH	h min	X	Y	RH	LH	
1/4"	.43	1.5	2ER1.5TR...	2EL1.5TR...	.035	.03	.04	-	-	NL...-2 (LH)
		1.5	3ER1.5TR...	3EL1.5TR...	.035	.04	.04			
3/8"	.63	2.0	3ER2.0TR...	3EL2.0TR...	.049	.04	.05	YE3	YI3	AL...-3 (LH)
		2.5	3ER2.5TR...	3EL2.5TR...	.061	.05	.06			
		3.0	3ER3.0TR...	3EL3.0TR...	.069	.05	.06			
1/2"	.87	4.0	4ER4.0TR...	4EL4.0TR...	.089	.07	.07	YE4	YI4	AL...-4 (LH)
		5.0	4ER5.0TR...	4EL5.0TR...	.108	.08	.10			
1/2"F	.91	4.0	4FER4.0TR...		.089	.07	.07	YE4F		AL...-4F
		5.0	4FER5.0TR...		.108	.08	.10			
		6.0	4FER6.0TR...		.138	.09	.11			
5/8"	1.06	6.0	5ER6.0TR...	5EL6.0TR...	.138	.09	.11	YE5	YI5	AL...-5 (LH)

U Style



Insert Size		Pitch	Ordering Code		Dimensions inch			Anvil		Toolholder
IC	L inch	mm	RH+LH		h min	X	Y	RH	LH	
1/2"U	.87	6.0	4UE6.0TR...		.138	.08	.43	YE4U	YI4U	AL...-4U (LH)
		7.0	4UE7.0TR...		.157	.09	.43			
		8.0	4UE8.0TR...		.177	.10	.43			
5/8"U	1.06	8.0	5UE8.0TR...		.177	.10	.54	YE5U	YI5U	AL...-5U (LH)
		9.0	5UE9.0TR...		.197	.12	.54			

V Style



Insert Size		Pitch	Ordering Code		Dimensions inch				Toolholder
IC	L inch	mm	RH	LH	h min	X	Y	T	
5/8"V	1.06	6.0	5VER6.0TR...	5VEL6.0TR...	.138	.04	.13	.24	NL...-5V-6 (LH)
		7.0	5VER7.0TR...	5VEL7.0TR...	.157	.04	.13	.24	
		8.0	5VER8.0TR...	5VEL8.0TR...	.177	.04	.13	.24	NL...-5V-8 (LH)
		9.0	5VER9.0TR...	5VEL9.0TR...	.197	.04	.17	.31	
		10.0	5VER10.0TR...	5VEL10.0TR...	.217	.04	.17	.31	
		12.0	5VER12.0TR...	5VEL12.0TR...	.256	.04	.20	.39	NL...-5V-10 (LH)

Trapez (con't)

MEGALINE

External

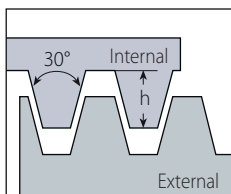

Defined by: DIN 103
Tolerance class: 7e/7H

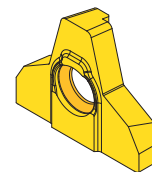
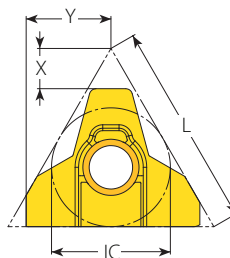

Mega Line

External

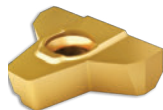

Insert Size		Pitch	Ordering Code	EDP No.	Dimensions inch			Number of Passes	
IC	L inch	mm	RH	VKX	h min	X	Y	0.003inch-Min. Depth of Cut (On radius)	0.006inch-Max. Depth of Cut (On radius)
5/8" MG	1.06	12.0	5MGER12.0TR...	42540	.256	.21	.44	94	44
		14.0	5MGER14.0TR...	42541	.315	.17		115	54
		16.0	5MGER16.0TR...	42530	.354	.21		129	60
		18.0	5MGER18.0TR...	42531	.394	.21		143	67
		20.0	5MGER20.0TR...	42532	.433	.29		158	74
		24.0	5MGER24.0TR...	42533	.512	.29		186	87

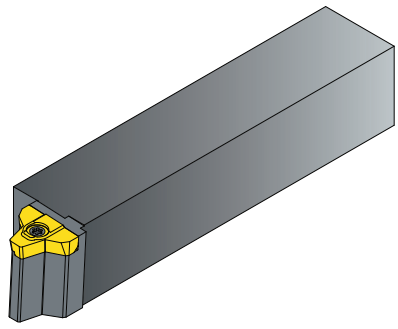
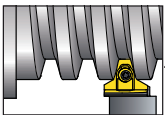

Recommended thread infeed method for Mega Line: Flank or Modified Flank 1°.

External Toolholders for Trapez



External

Spare Parts

Insert	Ordering Code	EDP No.	Dimensions inch				Thread Diameter Range (Min.-Max.)		
			RH	H=B=H1	F	L1			
5MGER12.0TR...	NL100-5MG12TR	66491	1.00	.65	6.1	.87	(TR44-300)x12	S5MG	K6T
	NL125-5MG12TR	66492	1.25	.93	6.9				
	NL150-5MG12TR	66493	1.50	1.24	8.1				
5MGER14.0TR...	NL100-5MG14TR	66494	1.00	.65	6.1	.87	(TR55-145)x14		
	NL125-5MG14TR	66495	1.25	.93	6.9				
	NL150-5MG14TR	66496	1.50	1.24	8.1				
5MGER16.0TR...	NL100-5MG16TR	66497	1.00	.65	6.1	.87	(TR65-175)x16		
	NL125-5MG16TR	66498	1.25	.93	6.9				
	NL150-5MG16TR	66499	1.50	1.24	8.1				
5MGER18.0TR...	NL100-5MG18TR	66500	1.00	.65	6.1	.87	(TR85-200)x18		
	NL125-5MG18TR	66501	1.25	.93	6.9				
	NL150-5MG18TR	66502	1.50	1.24	8.1				
5MGER20.0TR...	NL100-5MG20TR	66503	1.00	.65	6.1	.87	(TR100-230)x20		
	NL125-5MG20TR	66504	1.25	.93	6.9				
	NL150-5MG20TR	66505	1.50	1.24	8.1				
5MGER24.0TR...	NL100-5MG24TR	66506	1.00	.65	6.1	.87	(TR135-300)x24		
	NL125-5MG24TR	66507	1.25	.93	6.9				
	NL150-5MG24TR	66508	1.50	1.24	8.1				

Recommended thread infeed method for Mega Line: Flank or Modified Flank 1°.

Trapez (con't)

Internal

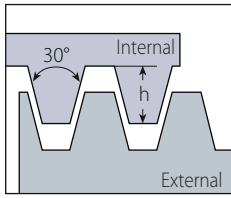

Defined by: DIN 103
Tolerance class: 7e/7H

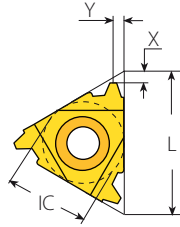

Standard

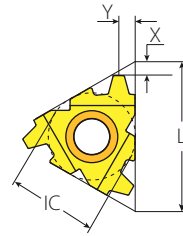

F-Line

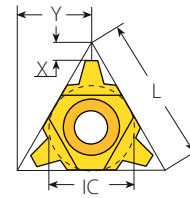

U Style

Standard

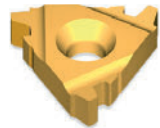

FLINE

	Insert Size		Pitch	Ordering Code		Dimensions inch			Anvil		Toolholder
	IC	L inch	mm	RH	LH	h min	X	Y	RH	LH	
1/4"	.43	1.5	2IR1.5TR...	2IL1.5TR...	.035	.03	.04	-	-	NVR 8-2 (LH)	
			3IR1.5TR...	3IL1.5TR...	.035	.04	.04	-	-		
			3IR2.0TR...	3IL2.0TR...	.049	.04	.05	YI3	YE3	AVR..-3 (LH)	
3/8"	.63	2.5	3IR2.5TR...	3IL2.5TR...	.060	.05	.06				
			3IR3.0TR...	3IL3.0TR...	.069	.05	.06				
			4IR4.0TR...	4IL4.0TR...	.089	.07	.07				
1/2"	.87	5.0	4IR5.0TR...	4IL5.0TR...	.108	.08	.10	YI4	YE4	AVR..-4 (LH)	
			4IR6.0TR...	4IL6.0TR...	.138	.09	.11				
			4FIR4.0TR...		.089	.07	.07				
1/2"F	.91	5.0	4FIR5.0TR...		.108	.08	.10	YI4F		AVRC...-4F	
			4FIR6.0TR...		.138	.09	.11				
5/8"	1.06	6.0	5IR6.0TR...	5IL6.0TR...	.138	.09	.11	YI5	YE5	AVR..-5 (LH)	

Trapez (con't)

Internal

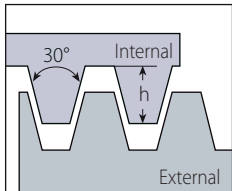

Defined by: DIN 103
Tolerance class: 7e/7H

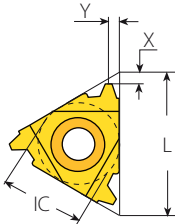

Coarse Pitch

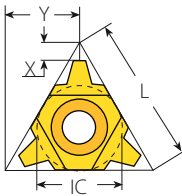

U Style Coarse Pitch

Coarse Pitch RH

	Thread	Insert Size		Ordering Code	Dimensions inch			Toolholder RH	Min Bore Dia.
		IC	L inch	RH	h min	X	Y	Inch	Inch
	TR18x4	3/8"U	.63	3UIR4.0TR158/013...	.089	.08	.31	NVRC044-3U-157/020	.55
	TR20x4	3/8"	.63	3IR4.0TR158/012...	.089	.06	.07	NVRC050-3-157/006	.63
	TR22x5	3/8"U	.63	3UIR5.0TR158/011...	.108	.06	.31	NVRC055-3U-157/018	.67
	TR24x5			3UIR5.0TR158/011...	.108	.06	.31	NVRC059-3U-157/019	.75
	TR26x5			3UIR5.0TR158/011...	.108	.06	.31	NVRC059-3U-157/019	.83
	TR28x5	1/2"	.87	4IR5.0TR...	.108	.09	.11	NVRC075-4-157/008	.91
	TR30x6	1/2"U	.87	4UIR6.0TR158/007...	.138	.08	.43	NVRC075-4U-157/011	.94
	TR36x6	5/8"	1.06	5IR6.0TR...	.138	.09	.11	NVRC100-5-157/012	1.18
	TR38x7	1/2"U	.87	4UIR7.0TR158/008...	.157	.09	.43	NVRC100-4U-157/013	1.22
	TR40x7			4UIR7.0TR158/008...	.157	.09	.43	NVRC100-4U-157/013	1.30
TR42x7	4UIR7.0TR158/008...			.157	.09	.43	NVRC125-4U-157/014	1.38	
TR44x7	4UIR7.0TR158/008...			.157	.09	.43	NVRC125-4U-157/014	1.46	
TR46x8	5/8"U	1.06	5UIR8.0TR158/010...	.177	.10	.53	NVRC125-5U-157/015	1.50	
TR48x8			5UIR8.0TR158/010...	.177	.10	.53	NVRC125-5U-157/015	1.57	
TR50x8			5UIR8.0TR158/010...	.177	.10	.53	NVRC125-5U-157/015	1.65	
TR52x8			5UIR8.0TR158/010...	.177	.10	.53	NVRC125-5U-157/015	1.73	

Coarse Pitch LH

	Thread	Insert Size		Ordering Code	Dimensions inch			Toolholder LH	Min Bore Dia.
		IC	L inch	LH	h min	X	Y	Inch	Inch
	TR18x4	3/8"U	.63	3UIR4.0TR158/013...	.089	.08	.31	NVRC044-3ULH-157/038	.55
	TR20x4	3/8"	.63	3IL4.0TR158/015...	.089	.06	.07	NVRC050-3LH-157/030	.63
	TR22x5	3/8"U	.63	3UIR5.0TR158/011...	.108	.06	.31	NVRC055-3ULH-157/036	.67
	TR24x5			3UIR5.0TR158/011...	.108	.06	.31	NVRC059-3ULH-157/037	.75
	TR26x5			3UIR5.0TR158/011...	.108	.06	.31	NVRC059-3ULH-157/037	.83
	TR28x5	1/2"	.87	4IL5.0TR...	.108	.09	.11	NVRC075-4LH-157/017	.91
	TR30x6	1/2"U	.87	4UIR6.0TR158/007...	.138	.08	.43	NVRC075-4ULH-157/024	.94
	TR36x6	5/8"	1.06	5IL6.0TR...	.138	.09	.11	NVRC100-5LH-157/031	1.18
	TR38x7	1/2"U	.87	4UIR7.0TR158/008...	.157	.09	.43	NVRC100-4ULH-157/032	1.22
	TR40x7			4UIR7.0TR158/008...	.157	.09	.43	NVRC100-4ULH-157/032	1.30
TR42x7	4UIR7.0TR158/008...			.157	.09	.43	NVRC125-4ULH-157/033	1.38	
TR44x7	4UIR7.0TR158/008...			.157	.09	.43	NVRC125-4ULH-157/033	1.46	
TR46x8	5/8"U	1.06	5UIR8.0TR158/010...	.177	.10	.53	NVRC125-5ULH-157/034	1.50	
TR48x8			5UIR8.0TR158/010...	.177	.10	.53	NVRC125-5ULH-157/034	1.57	
TR50x8			5UIR8.0TR158/010...	.177	.10	.53	NVRC125-5ULH-157/034	1.65	
TR52x8			5UIR8.0TR158/010...	.177	.10	.53	NVRC125-5ULH-157/034	1.73	

U Type RH inserts can be used for both LH and RH applications.

Trapez (con't)

Internal

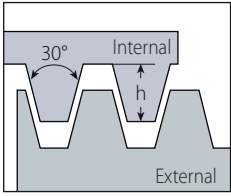

Defined by: DIN 103
Tolerance class: 7e/7H

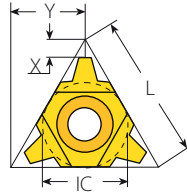

U Style

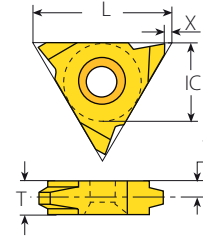

V Style

U Style



Insert Size		Pitch	Ordering Code		Dimensions inch			Anvil		Toolholder
IC	L inch	mm	RH+LH		h min	X	Y	RH	LH	
1/2"U	.87	6.0	4UI6.0TR...		.138	.08	.43	YI4U	YE4U	AVR..-4U (LH)
		7.0	4UI7.0TR...		.157	.09	.43			
		8.0	4UI8.0TR...		.177	.10	.43			
5/8"U	1.06	8.0	5UI8.0TR...		.177	.10	.54	YI5U	YE5U	AVR..-5U (LH)
		9.0	5UI9.0TR...		.197	.12	.54			

V Style



Insert Size		Pitch	Ordering Code		Dimensions inch				Toolholder
IC	L inch	mm	RH	LH	h min	X	Y	T	
5/8"V	1.06	6.0	5VIR6.0TR...	5VIL6.0TR...	.138	.04	.13	.24	NVR..-5V (LH)
		7.0	5VIR7.0TR...	5VIL7.0TR...	.157	.04	.13	.24	
		8.0	5VIR8.0TR...	5VIL8.0TR...	.177	.04	.13	.24	
		9.0	5VIR9.0TR...	5VIL9.0TR...	.197	.04	.17	.31	
		10.0	5VIR10.0TR...	5VIL10.0TR...	.217	.04	.17	.31	
		12.0	5VIR12.0TR...	5VIL12.0TR...	.256	.04	.20	.39	

Trapez

MEGA LINE

Internal

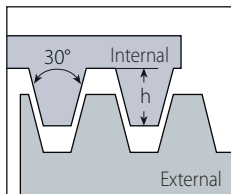

Defined by: DIN 103
Tolerance class: 7e/7H

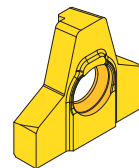

Mega Line

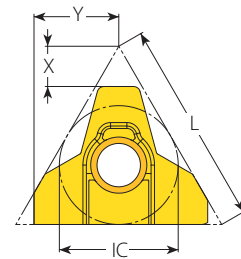

Internal

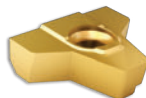

Insert Size		Pitch	Ordering Code	EDP No.	Dimensions inch			Number of Passes	
IC	L inch	mm	RH	VKX	h min	X	Y	0.003inch-Min. Depth of Cut (On radius)	0.006inch-Max. Depth of Cut (On radius)
5/8" MG	1.06	12.0	5MGIR12.0TR...	42534	.25	.21	.41	96	45
		14.0	5MGIR14.0TR...	42535	.31	.17		118	55
		16.0	5MGIR16.0TR...	42536	.35	.21		131	61
		18.0	5MGIR18.0TR...	42537	.39	.21		145	68
		20.0	5MGIR20.0TR...	42538	.43	.29		160	75
		24.0	5MGIR24.0TR...	42539	.51	.29		188	88

Recommended thread infeed method for Mega Line: Flank or Modified Flank 1°.

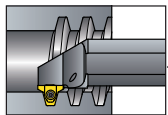

Internal Toolholders for Trapez

MEGA/LINE

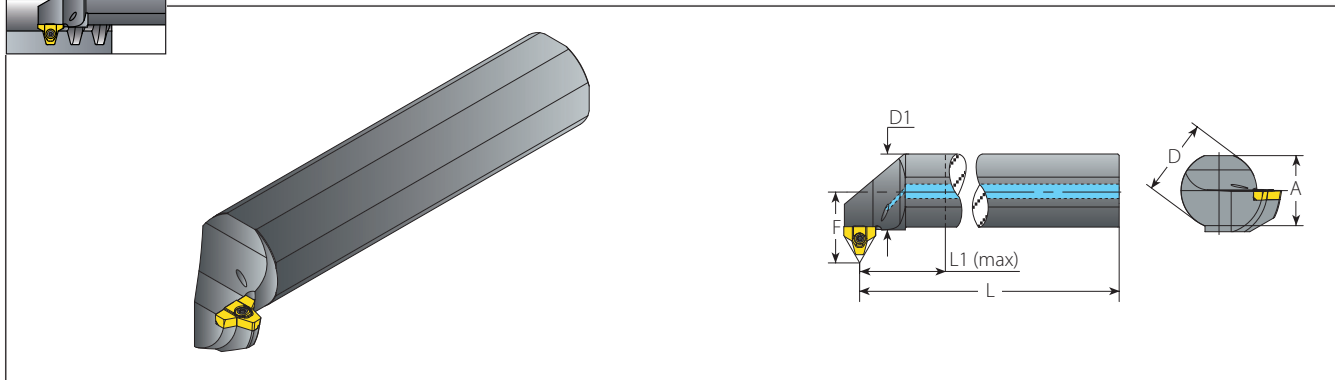

Internal

Spare Parts

Insert	Ordering Code	EDP No.	Dimensions inch							Min. Bore Dia.	Thread Diameter Range (Min.-Max.)		Spare Parts	
			A	L	L1 (max)	D	D1	F	inch		Short Chip Material	Long Chip Material	Insert Screw	Torx Key
	RH													
5MGIR12.OTR...	NVRC150-5MG12TR	66509	1.42	9.15	4	1.5	1.49	1.63	2.87	(TR85-300)x12	(TR85-300)x12	S5MG	K6T	
	NVRC200-5MG12TR	66510	1.81	10.15	5	2.0	1.99	1.83	2.87	(TR85-300)x12	(TR95-300)x12			
	NVRC250-5MG12TR	66511	2.28	11.10	6	2.5	2.49	2.03	3.27	(TR95-300)x12	(TR105-300)x12			
5MGIR14.OTR...	NVRC150-5MG14TR	66512	1.42	9.15	4	1.5	1.49	1.63	3.98	(TR115-145)x14	(TR115-145)x14			
	NVRC200-5MG14TR	66513	1.81	10.15	5	2.0	1.99	1.83	3.98	(TR115-145)x14	(TR115-145)x14			
	NVRC250-5MG14TR	66514	2.28	11.10	6	2.5	2.49	2.03	3.98	(TR115-145)x14	(TR115-145)x14			
5MGIR16.OTR...	NVRC150-5MG16TR	66515	1.42	9.15	4	1.5	1.49	1.63	2.52	(TR80-175)x16	(TR150-175)x16			
	NVRC200-5MG16TR	66516	1.81	10.15	5	2.0	1.99	1.83	5.28	(TR150-175)x16	(TR150-175)x16			
	NVRC250-5MG16TR	66517	2.28	11.10	6	2.5	2.49	2.03	5.28	(TR150-175)x16	(TR150-175)x16			
5MGIR18.OTR...	NVRC150-5MG18TR	66518	1.42	9.15	4	1.5	1.49	1.63	2.64	(TR85-200)x18	(TR90-200)x18			
	NVRC200-5MG18TR	66519	1.81	10.15	5	2.0	1.99	1.83	2.83	(TR90-200)x18	(TR180-200)x18			
	NVRC250-5MG18TR	66520	2.28	11.10	6	2.5	2.49	2.03	6.38	(TR180-200)x18	(TR180-200)x18			
5MGIR20.OTR...	NVRC150-5MG20TR	66521	1.42	9.15	4	1.5	1.49	1.63	3.15	(TR100-230)x20	(TR100-230)x20			
	NVRC200-5MG20TR	66522	1.81	10.15	5	2.0	1.99	1.83	3.15	(TR100-230)x20	(TR100-230)x20			
	NVRC250-5MG20TR	66523	2.28	11.10	6	2.5	2.49	2.03	3.35	(TR105-230)x20	(TR210-230)x20			
5MGIR24.OTR...	NVRC150-5MG24TR	66524	1.42	9.15	4	1.5	1.49	1.63	4.37	(TR135-300)x24	(TR135-300)x24			
	NVRC200-5MG24TR	66525	1.81	10.15	5	2.0	1.99	1.83	4.37	(TR135-300)x24	(TR135-300)x24			
	NVRC250-5MG24TR	66526	2.28	11.10	6	2.5	2.49	2.03	4.37	(TR135-300)x24	(TR135-300)x24			

Recommended thread infeed method for Mega Line: Flank or Modified Flank 1°.

Trapez (con't)

Mini-V

Internal

Defined by: DIN 103
Tolerance class: 7e/7H

Mini-V



Min. Thread	Insert Style	Pitch	Ordering Code		Dimensions inch				Helix	Toolholder
			RH	d	T	F	Y	h min		
TR10x2.0	V08	2.0	V08TH2.0TRR...	.24	.15	.19	.04	.05	3.5	.V08-...
TR11x3.0		3.0	V08TH3.0TRR...			.19	.05	.07	5	
TR16x4.0	V11	4.0	V11TH4.0TRR...	.31	.17	.26	.06	.09	4.5	.V11-...

Trapez

MINIPRO

Internal

Defined by: DIN 103
Tolerance class: 7e/7H

Mini-3 Standard



Insert Size		Pitch	Ordering Code		Dimensions inch			Min. Bore Dia.	Toolholder
IC mm	L inch		mm	RH	LH	h min	Y	F	
5.0	.31	1.5	5.0KIR1.5TR...	5.0KIL1.5TR...	.033	.03	.19	.31	.NVR...-5.0K (LH)
6.0	.39	1.5	6.0KIR1.5TR...	6.0KIL1.5TR...	.033	.03	.21	.39	.NVR...-6.0K (LH)
		2.0	6.0KIR2.0TR...	6.0KIL2.0TR...	.049	.05	.21	.39	

Mini-3 U Style



Insert Size		Pitch	Ordering Code		Dimensions inch			Min. Bore Dia.	Toolholder
IC mm	L inch		mm	RH+LH	h min	Y	F	inch	
5.0U	.31	2.0	5.0KUI2TR...		.049	.16	.22	.35	.NVR...-5.0KU (LH)

Mini-L



Insert Size		Pitch	Ordering Code		Dimensions inch			Min. Bore Dia.	Toolholder
IC mm	mm		RH	LH	h min	Y	F	inch	
5.0L	1.5	5LKIR1.5TR...	5LKIL1.5TR...	.033	.03	.18	.31	.NVR...-5LK (LH)	
	2.0	5LKIR2.0TR...	5LKIL2.0TR...	.049	.05	.19	.35		

American ACME

External

Defined by: ANSI B1.5:1988
Tolerance class: 3G

Standard

	Insert Size		Pitch	Ordering Code		Dimensions inch			Anvil		Toolholder
	IC	L inch	TPI	RH	LH	h min	X	Y	RH	LH	
	1/4"	0.43	16	2ER16ACME...	2EL16ACME...	.036	.04	.04	-	-	NL..-2 (LH)
			14	3ER14ACME...	3EL14ACME...	.041	.04	.05			
	3/8"	.63	12	3ER12ACME...	3EL12ACME...	.047	.04	.05	YE3	YI3	AL..-3 (LH)
			10	3ER10ACME...	3EL10ACME...	.060	.05	.06			
			8	3ER8ACME...	3EL8ACME...	.072	.06	.06			
			7	3ER7ACME...	3EL7ACME...	.082	.07	.09			
1/2"	.87	7	4ER7ACME...	4EL7ACME...	.082	.07	.09	YE4	YI4	AL..-4 (LH)	
		6	4ER6ACME...	4EL6ACME...	.093	.07	.08				
		5	4ER5ACME...	4EL5ACME...	.110	.08	.09				
1/2" F	.91	6	4FER6ACME...		.093	.07	.08	YE4F		AL...-4F	
		5	4FER5ACME...		.110	.08	.09				
5/8"	1.06	4	5ER4ACME...	5EL4ACME...	.135	.09	.11	YE5	YI5	AL..-5 (LH)	

F.LINE

U Style

	Insert Size		Pitch	Ordering Code		Dimensions inch			Anvil		Toolholder
	IC	L inch	TPI	RH+LH		h min	X	Y	RH	LH	
	1/2" U	.87	4	4UE4ACME...		.135	.09	.43	YE4U	YI4U	AL..-4U (LH)
			3	4UE3ACME...		.177	.12	.43			
5/8" U	1.06	3	5UE3ACME...		.177	.12	.54	YE5U	YI5U	AL..-5U (LH)	

V Style

	Insert Size		Pitch	Ordering Code		Dimensions inch				Toolholder
	IC	L inch	TPI	RH	LH	h min	X	Y	T	
	5/8" V	1.06	4	5VER4ACME...	5VEL4ACME...	.135	.04	.13	.24	NL..-5V-6 (LH)
			3.5	5VER3.5ACME...	5VEL3.5ACME...	.152	.04	.13	.24	
			3	5VER3ACME...	5VEL3ACME...	.177	.04	.13	.24	
			2	5VER2ACME...	5VEL2ACME...	.260	.04	.20	.39	

On Edge

	Insert Size		Pitch	Ordering Code		Dimensions inch				
	IC	L inch	TPI	RH		h min	T	Ø C	X	Y
	1/2"	.87	12	TNEC43E112ACME...		.047	.19	.20	.02	.09
			10	TNEC43E110ACME...		.060				
			8	TNEC43E108ACME...		.072				
			6	TNEC43E106ACME...		.093				
			4	TNEC43E104ACME...		.135				
5/8"	1.06	4	TNEC54E104ACME...		.135	.25	.26		.13	
		3	TNEC54E103ACME...		.177					
3/4"	1.26	2	TNEC56E102ACME...		.260	.38	.31		.19	

On Edge inserts are suited to existing toolholders on the market.

American ACME (con't)

MEGALINE

External

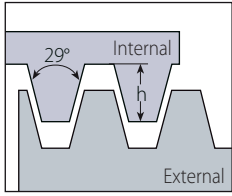

Defined by: ANSI B1.5:1988
Tolerance class: 3G

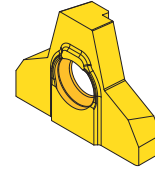
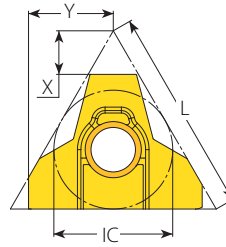

Mega Line

External

Insert Size	Pitch	Ordering Code	EDP No.	Dimensions inch			Number of Passes			
				IC	L inch	TPI	RH	VKX	h min	X
5/8" MG	1.06	2	5MGER2ACME...	42511	.260	.19	.45		95	44
		1 1/2	5MGER1-1/2ACME...	42508	.343	.23			125	58
		1 1/3	5MGER1-1/3ACME...	42509	.385	.27			140	65
		1	5MGER1ACME...	42510	.510	.33			186	87

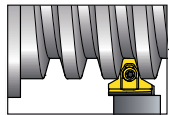

External Toolholders for American ACME

MEGALINE

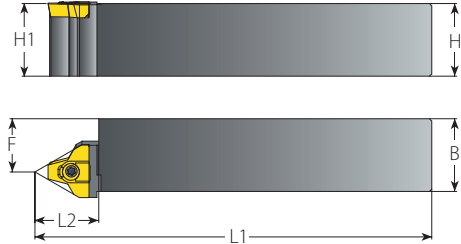
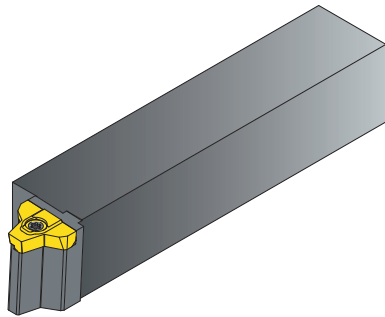

External

Spare Parts

Insert	Ordering Code	EDP No.	Dimensions				Thread Diameter Range (Min.-Max.)	Insert Screw	Torx Key
			H=B=H1	F	L1	L2			
5MGER2ACME...	NL100-5MG2ACME	66409	1.00	.65	6.1	.87	(3"-5")-2ACME	S5MG	K6T
	NL125-5MG2ACME	66410	1.25	.93	6.9				
	NL150-5MG2ACME	66412	1.50	1.24	8.1				
5MGER1-1/2ACME...	NL100-5MG1-1/2ACME	66413	1.00	.65	6.1	.87	(3"-5")-1 1/2ACME	S5MG	K6T
	NL125-5MG1-1/2ACME	66414	1.25	.93	6.9				
	NL150-5MG1-1/2ACME	66415	1.50	1.24	8.1				
5MGER1-1/3ACME...	NL100-5MG1-1/3ACME	66416	1.00	.65	6.1	.87	(3"-5")-1 1/3ACME	S5MG	K6T
	NL125-5MG1-1/3ACME	66417	1.25	.93	6.9				
	NL150-5MG1-1/3ACME	66418	1.50	1.24	8.1				
5MGER1ACME...	NL100-5MG1ACME	66420	1.00	.65	6.1	.87	(3.5"-5")-1ACME	S5MG	K6T
	NL125-5MG1ACME	66422	1.25	.93	6.9				
	NL150-5MG1ACME	66423	1.50	1.24	8.1				

Recommended thread infeed method for Mega Line: Flank or Modified Flank 1°.

American ACME (con't)

Internal

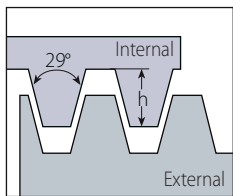

Defined by: ANSI B1.5:1988
Tolerance class: 3G

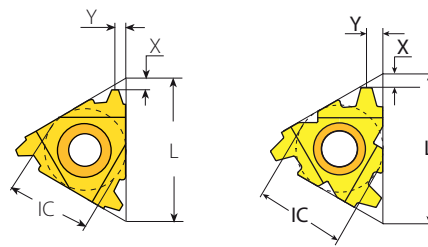

Standard

F-Line

Standard



FLINE

Insert Size		Pitch	Ordering Code		Dimensions inch			Anvil		Toolholder
IC	L inch	TPI	RH	LH	h min	X	Y	RH	LH	
1/4"	.43	16	2IR16ACME...	2IL16ACME...	.036	.04	.04	-	-	NVR..-2 (LH)
		16	3IR16ACME...	3IL16ACME...	.036	.04	.04			
3/8"	.63	14	3IR14ACME...	3IL14ACME...	.041	.04	.05	Y13	YE3	AVR..-3 (LH)
		12	3IR12ACME...	3IL12ACME...	.047	.05	.05			
		10	3IR10ACME...	3IL10ACME...	.060	.05	.05			
		8	3IR8ACME...	3IL8ACME...	.072	.06	.06			
1/2"	.87	6	4IR6ACME...	4IL6ACME...	.093	.07	.08	Y14	YE4	AVR..-4 (LH)
		5	4IR5ACME...	4IL5ACME...	.110	.08	.09			
1/2"F	.91	6	4FIR6ACME...		.093	.07	.08	Y14F		AVRC...-4F
		5	4FIR5ACME...		.110	.08	.09			
5/8"	1.06	4	5IR4ACME...	5IL4ACME...	.135	.09	.10	Y15	YE5	AVR..-5 (LH)

American ACME (con't)

Internal

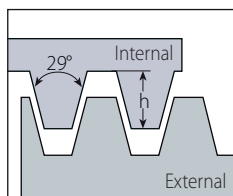

Defined by: ANSI B1.5:1988
Tolerance class: 3G

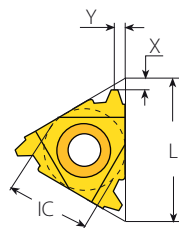

Standard

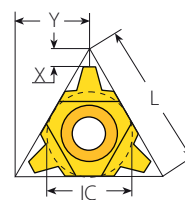

U Style

Coarse Pitch RH



Thread	Insert Size		Ordering Code	Dimensions inch			Anvil	Min Bore Dia.		
	TPI	IC		L inch	RH	h min			X	Y
1/2"x10	6.0U	.39	6.0KUIR10ACME158/005...		.060	.04	.20	-	NVRC032-6.0KU-157/003	.40
5/8"x8	1/4"U	.43	2UIR8ACME158/006...		.072	.04	.22	-	NVRC039-2U-157/004	.50
3/4"x6	3/8"	.63	3IR6ACME...		.093	.07	.07	-	NVRC044-3-157/005	.58
7/8"x6			3IR6ACME...		.093	.07	.07	-	NVRC050-3-157/006	.73
1"x5	1/2"	.87	4IR5ACME158/018...		.110	.08	.09	-	NVRC067-4-157/039	.83
1 1/8"x5			4IR5ACME...		.110	.08	.09	-	NVRC075-4-157/008	.94
1 1/4"x5			4IR5ACME...		.110	.08	.09	-	NVRC075-4-157/009	1.07
1 1/2"x4	5/8"	1.06	5IR4ACME...		.135	.09	.10	-	NVRC110-5-157/010	1.27
1 3/4"x4			5IR4ACME...		.135	.09	.10	YI5-1P	AVRC125-5	1.53

Coarse Pitch LH



Thread	Insert Size		Ordering Code	Dimensions inch			Anvil	Min Bore Dia.		
	TPI	IC		L inch	LH	h min			X	Y
1/2"x10	6.0U	.39	6.0KUIR10ACME158/005...		.060	.04	.20	-	NVRC032-6.0KULH-157/027	.40
5/8"x8	1/4"U	.43	2UIR8ACME158/006...		.072	.04	.22	-	NVRC039-2ULH-157/028	.50
3/4"x6	3/8"	.63	3IL6ACME...		.093	.07	.07	-	NVRC044-3LH-157/029	.58
7/8"x6			3IL6ACME...		.093	.07	.07	-	NVRC050-3LH-157/030	.73
1"x5	1/2"	.87	4IL5ACME158/019...		.110	.08	.09	-	NVRC067-4LH-157/040	.83
1 1/8"x5			4IL5ACME...		.110	.08	.09	-	NVRC075-4LH-157/017	.94
1 1/4"x5			4IL5ACME...		.110	.08	.09	-	NVRC075-4LH-157/021	1.07
1 1/2"x4	5/8"	1.06	5IL4ACME...		.135	.09	.10	-	NVRC110-5LH-157/023	1.27
1 3/4"x4			5IL4ACME...		.135	.09	.10	YE5-1P	AVRC125-5LH	1.53

U Type RH inserts can be used for both LH and RH applications.

U Style



Insert Size	Pitch	Ordering Code	Dimensions inch			Anvil				
			IC	L inch	TPI	RH+LH	h min	X	Y	RH
1/2"U	.87	4	4UI4ACME...		.135	.09	.43	YI4U	YE4U	AVR..-4U (LH)
			4UI3ACME...		.177	.11	.43			
5/8"U	1.06	3	SUI3ACME...		.177	.11	.54	YI5U	YE5U	AVR..-5U(LH)

American ACME (con't)

Internal

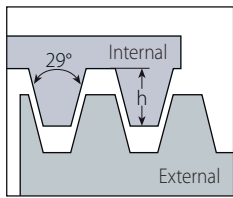

Defined by: ANSI B1.5:1988
Tolerance class: 3G

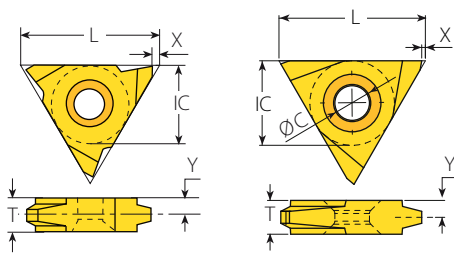

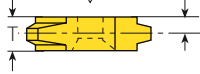

V Style

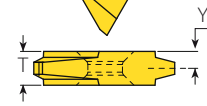

On Edge

V Style



Insert Size		Pitch	Ordering Code		Dimensions inch				Toolholder
IC	L inch	TPI	RH	LH	h min	X	Y	T	
5/8"V	1.06	4	5VIR4ACME...	5VIL4ACME...	.135	.04	.13	.24	NVR...-5V (LH)
		3.5	5VIR3.5ACME...	5VIL3.5ACME...	.152	.04	.13	.24	
		3	5VIR3ACME...	5VIL3ACME...	.177	.04	.13	.24	
		2	5VIR2ACME...	5VIL2ACME...	.260	.04	.20	.39	

On Edge



Insert Size		Pitch	Ordering Code		Dimensions inch				
IC	L inch	TPI	RH	LH	h min	T	Ø C	X	Y
1/2"	.87	12	TNEC43EI12ACME...		.047	.19	.20	.02	.09
		10	TNEC43EI10ACME...		.060				
		8	TNEC43EI8ACME...		.072				
		6	TNEC43EI6ACME...		.093				
		4	TNEC43EI4ACME...		.135				
5/8"	1.06	4	TNEC54EI4ACME...		.135	.25	.26	.13	
		3	TNEC54EI3ACME...		.177				
3/4"	1.26	2	TNEC56EI2ACME...		.260	.38	.31	.19	

On Edge inserts are suited to existing toolholders on the market.

American ACME (con't)

MEGALINE

Internal

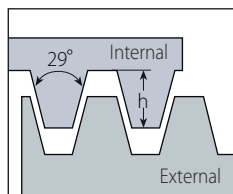

Defined by: ANSI B1.5:1988
Tolerance class: 3G

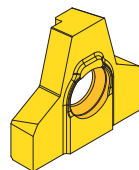

Mega Line

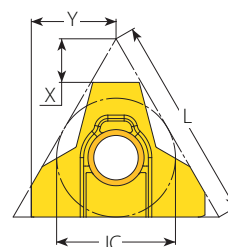

Internal

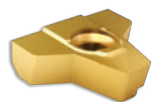

Insert Size	Pitch	Ordering Code	EDP No.	Dimensions inch			Number of Passes			
				IC	L inch	TPI	RH	VKX	h min	X
5/8" MG	1.06	2	5MGIR2ACME...	42507	.257	.19	.41		94	44
		1 1/2	5MGIR1-1/2ACME...	42504	.337	.23			124	58
		1 1/3	5MGIR1-1/3ACME...	42505	.376	.27			139	65
		1	5MGIR1ACME...	42506	.495	.33			184	86

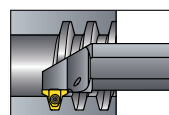

Internal Toolholders for American ACME

MEGALINE

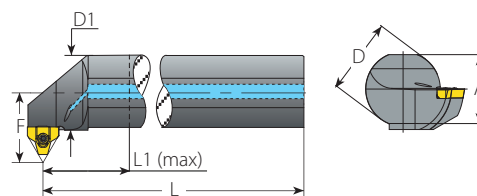
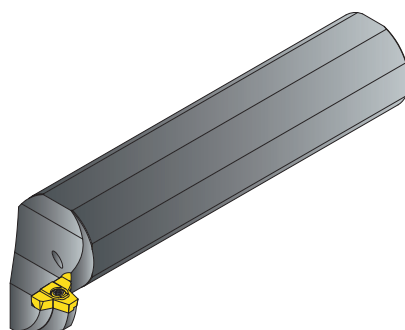

Internal

Insert	Ordering Code	EDP No.	Dimensions inch							Min. Bore Dia.	Thread Diameter Range (Min.-Max.)		Spare Parts	
			RH	A	L	L1 (max)	D	D1	F		inch	Short Chip Material	Long Chip Material	Insert Screw
5MGIR2ACME...	NVRC150-5MG2ACME	66424	1.42	9.15	4	1.5	1.49	1.63	2.50	(3"-5")-2ACME	(3.5"-5")-2ACME	S5MG	K6T	
	NVRC200-5MG2ACME	66425	1.81	10.15	5	2.0	1.99	1.83	3.00	(3.5"-5")-2ACME	(4"-5")-2ACME			
	NVRC250-5MG2ACME	66426	2.28	11.10	6	2.5	2.49	2.03	3.50	(4"-5")-2ACME	(4.5"-5")-2ACME			
5MGIR1-1/2ACME...	NVRC150-5MG1-1/2ACME	66434	1.42	9.15	4	1.5	1.49	1.63	2.33	(3"-5")-1 1/2ACME	(3.5"-5")-1 1/2ACME			
	NVRC200-5MG1-1/2ACME	66442	1.81	10.15	5	2.0	1.99	1.83	2.83	(3.5"-5")-1 1/2ACME	(4"-5")-1 1/2ACME			
	NVRC250-5MG1-1/2ACME	66443	2.28	11.10	6	2.5	2.49	2.03	3.33	(4"-5")-1 1/2ACME	(4.5"-5")-1 1/2ACME			
5MGIR1-1/3ACME...	NVRC150-5MG1-1/3ACME	66444	1.42	9.15	4	1.5	1.49	1.63	2.25	(3"-5")-1 1/3ACME	(3.5"-5")-1 1/3ACME			
	NVRC200-5MG1-1/3ACME	66445	1.81	10.15	5	2.0	1.99	1.83	2.75	(3.5"-5")-1 1/3ACME	(4.0"-5")-1 1/3ACME			
	NVRC250-5MG1-1/3ACME	66446	2.28	11.10	6	2.5	2.49	2.03	3.25	(4.0"-5")-1 1/3ACME	(4.5"-5")-1 1/3ACME			
5MGIR1ACME...	NVRC150-5MG1ACME	66447	1.42	9.15	4	1.5	1.49	1.63	2.50	(3.5"-5")-1ACME	(4"-5")-1ACME			
	NVRC200-5MG1ACME	66448	1.81	10.15	5	2.0	1.99	1.83	3.00	(4"-5")-1ACME	(4.5"-5")-1ACME			
	NVRC250-5MG1ACME	66449	2.28	11.10	6	2.5	2.49	2.03	3.00	(4"-5")-1ACME	(4.5"-5")-1ACME			

Recommended thread infeed method for Mega Line: Flank or Modified Flank 1°.

American ACME (con't)

MINIPRO

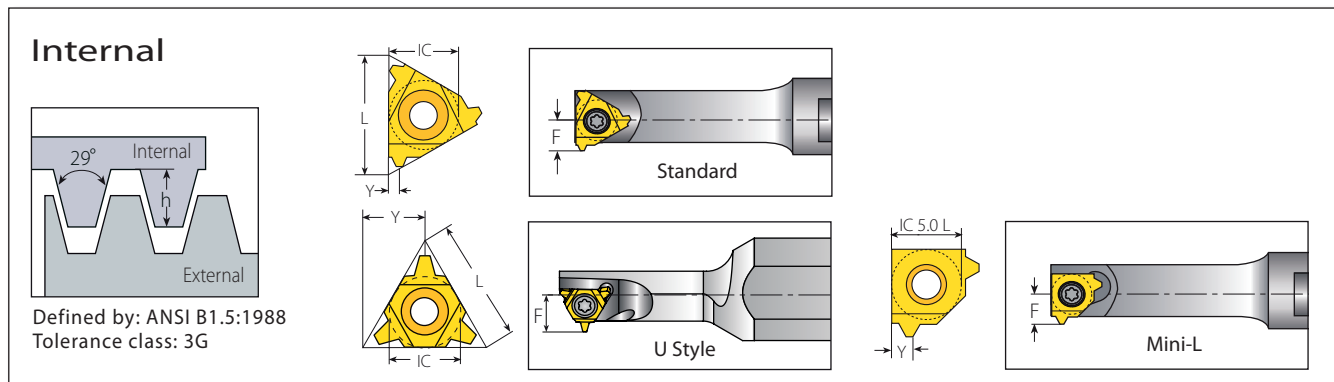

Mini-3 Standard



Insert Size		Pitch	Ordering Code		Dimensions inch			Min. Bore Dia.	Toolholder
IC mm	L inch	TPI	RH	LH	h min	Y	F	inch	
5.0	.31	16	5.0KIR16ACME...	5.0KIL16ACME...	.036	.03	.19	.31	.NVR...-5.0K (LH)
6.0	.39	12	6.0KIR12ACME...	6.0KIL12ACME...	.047	.04	.20	.39	.NVR...-6.0K (LH)

Mini-3 U Style



Insert Size		Pitch	Ordering Code		Dimensions inch			Min. Bore Dia.	Toolholder
IC mm	L inch	TPI	RH+LH		h min	Y	F	inch	
5.0U	.31	14	5.0KUI14ACME...		.041	.16	.23	.35	.NVR...-5.0KU (LH)
		12	5.0KUI12ACME...		.047				
		10	5.0KUI10ACME...		.060				

Mini-L



Insert Size		Pitch	Ordering Code		Dimensions inch			Min. Bore Dia.	Toolholder
IC mm	TPI	RH	LH	h min	Y	F	inch		
5.0L	12	5LKIR12ACME...	5LKIL12ACME...	.047	.04	.17	.31	.NVR...-5LK (LH)	

American ACME (2G)

External

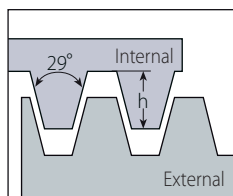

Defined by: ANSI B1.5:1988
Tolerance class: 2G

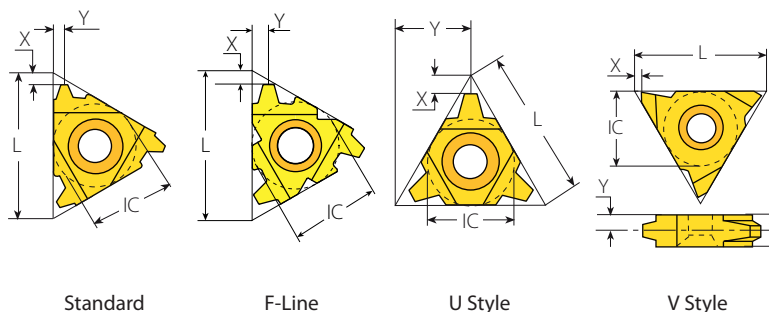

Standard



Insert Size		Pitch	Ordering Code		Dimensions inch			Anvil		Toolholder
IC	L inch	TPI	RH	LH	h min	X	Y	RH	LH	
3/8"	.63	10	3ER10ACME-2G...	3EL10ACME-2G...	1.52	.05	.06	YE3	YI3	AL...-3 (LH)
		8	3ER8ACME-2G...	3EL8ACME-2G...	1.84	.06	.06			
1/2"	.87	5	4ER5ACME-2G...	4EL5ACME-2G...	2.79	.08	.09	YE4	YI4	AL...-4 (LH)
1/2"F	.91	5	4FER5ACME-2G...		2.79	.08	.09			

U Style



Insert Size		Pitch	Ordering Code		Dimensions inch			Anvil		Toolholder
IC	L inch	TPI	RH+LH		h min	X	Y	RH	LH	
1/2"U	.87	4	4UE4ACME-2G...		.135	.09	.43	YE4U	YI4U	AL...-4U (LH)
		3.5	4UE3.5ACME-2G...		.152	.10	.43			
		3	4UE3ACME-2G...		.177	.12	.43			

V Style



Insert Size		Pitch	Ordering Code		Dimensions inch				Toolholder
IC	L inch	TPI	RH	LH	h min	X	Y	T	
5/8"V	1.06	4	5VER4ACME-2G...	5VEL4ACME-2G...	.135	.04	.13	.24	NL...-5V-6 (LH)
		3.5	5VER3.5ACME-2G...	5VEL3.5ACME-2G...	.152	.04	.13	.24	
		3	5VER3ACME-2G...	5VEL3ACME-2G...	.177	.04	.13	.24	

American ACME (2G) (con't)

Internal

Defined by: ANSI B1.5:1988
Tolerance class: 2G

Standard



Insert Size		Pitch	Ordering Code		Dimensions inch			Anvil		Toolholder
IC	L inch	TPI	RH	LH	h min	X	Y	RH	LH	
3/8"	.63	10	3IR10ACME-2G...	3IL10ACME-2G...	.060	.05	.05	YI3	YE3	AVR..-3 (LH)
		8	3IR8ACME-2G...	3IL8ACME-2G...	.072	.06	.06			
1/2"	.87	5	4IR5ACME-2G...	4IL5ACME-2G...	.110	.08	.09	YI4	YE4	AVR..-4 (LH)
1/2"F	.91	5	4FIR5ACME-2G...		.110	.08	.09	YI4F		AVRC...-4F



FLINE

U Style



Insert Size		Pitch	Ordering Code		Dimensions inch			Anvil		Toolholder
IC	L inch	TPI	RH+LH		h min	X	Y	RH	LH	
1/2"U	.87	4	4UI4ACME-2G...		.135	.09	.43	YI4U	YE4U	AVR..-4U (LH)
		3.5	4UI3.5ACME-2G...		.152	.10	.43			
		3	4UI3ACME-2G...		.177	.11	.43			

V Style



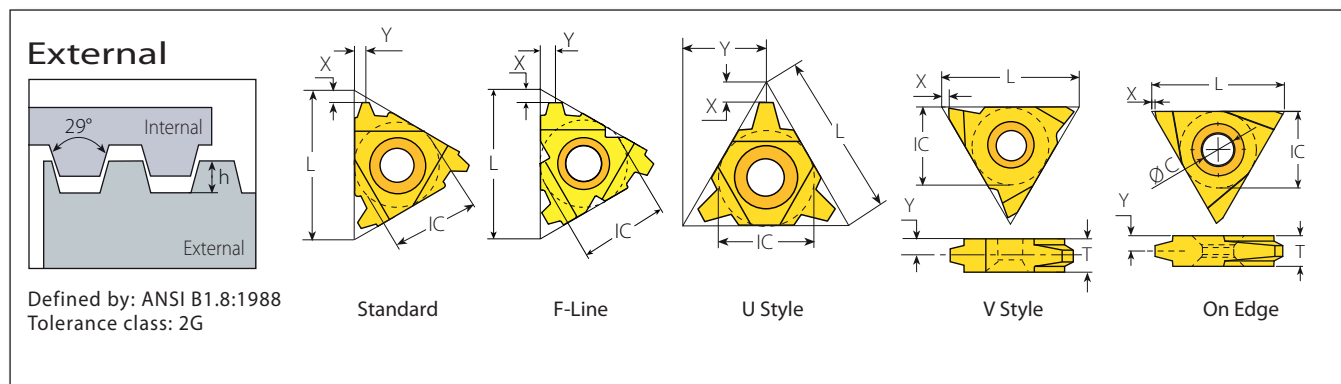

Insert Size		Pitch	Ordering Code		Dimensions inch				Toolholder
IC	L inch	TPI	RH	LH	h min	X	Y	T	
5/8"V	1.06	4	5VIR4ACME-2G...	5VIL4ACME-2G...	.135	.04	.13	.24	NVR..-5V (LH)
		3.5	5VIR3.5ACME-2G...	5VIL3.5ACME-2G...	.152	.04	.13	.24	
		3	5VIR3ACME-2G...	5VIL3ACME-2G...	.177	.04	.13	.24	

Stub ACME



Standard

IC	Insert Size		Pitch	Ordering Code		Dimensions inch			Anvil		Toolholder	
	L inch	TPI		RH	LH	h min	X	Y	RH	LH		
	3/8"	.43	16	2ER16STACME...	2EL16STACME...	.024	.04	.04	-	-	NL..-2 (LH)	
				3ER16STACME...	3EL16STACME...	.024	.04	.04	YE3	YI3	AL..-3 (LH)	
				14	3ER14STACME...	3EL14STACME...	.026	.04				.04
				12	3ER12STACME...	3EL12STACME...	.030	.05				.05
				10	3ER10STACME...	3EL10STACME...	.040	.05				.05
				8	3ER8STACME...	3EL8STACME...	.048	.05				.05
	1/2"	.87	6	4ER6STACME...	4EL6STACME...	.060	.07	.07	YE4	YI4	AL..-4 (LH)	
				5	4ER5STACME...	4EL5STACME...	.070	.08				.09
				4	4ER4STACME...	4EL4STACME...	.085	.09	.09	YE4F		AL...-4F
				6	4FER6STACME...		.060	.07	.07			
				5	4FER5STACME...		.070	.08	.09			
				4	4FER4STACME...		.085	.09	.09			
	5/8"	1.06	4	5ER4STACME...	5EL4STACME...	.085	.09	.09	YE5	YI5	AL..-5 (LH)	
				3	5ER3STACME...	5EL3STACME...	.110	.11				.11

U Style

IC	Insert Size		Pitch	Ordering Code		Dimensions inch			Anvil		Toolholder
	L inch	TPI		RH+LH	h min	X	Y	RH	LH		
	1/2"U	.87	4	4UE4STACME...	.085	.10	.43	YE4U	YI4U	AL..-4U (LH)	
				3	4UE3STACME...	.110	.13				.43

V Style

IC	Insert Size		Pitch	Ordering Code		Dimensions inch				Toolholder
	L inch	TPI		RH	LH	h min	X	Y	T	
	5/8"V	1.06	4	5VER4STACME...	5VEL4STACME...	.085	.04	.13	.24	NL..-5V-6 (LH)
			3	5VER3STACME...	5VEL3STACME...	.110	.04	.13	.24	
			2	5VER2STACME...	5VEL2STACME...	.160	.04	.17	.31	

On Edge

IC	Insert Size		Pitch	Ordering Code		Dimensions inch				
	L inch	TPI		RH	h min	T	ØC	X	Y	
	3/8"	.63	12	TNEC32EI12STACME...	.030	.13	.15	.04	.06	
			10	TNEC32EI10STACME...	.040					
			8	TNEC32EI8STACME...	.048					
<td rowspan="4">1/2"</td> <td rowspan="4">.87</td> <td>12</td> <td>TNEC43EI12STACME...</td> <td>.030</td> <td rowspan="4">.19</td> <td rowspan="4">.20</td> <td rowspan="4">.02</td> <td rowspan="4">.09</td>	1/2"	.87	12	TNEC43EI12STACME...	.030	.19	.20	.02	.09	
			10	TNEC43EI10STACME...	.040					
			8	TNEC43EI8STACME...	.048					
			6	TNEC43EI6STACME...	.060					
<td rowspan="2">5/8"</td> <td rowspan="2">1.06</td> <td>4</td> <td>TNEC43EI4STACME...</td> <td>.085</td> <td rowspan="2">.25</td> <td rowspan="2">.26</td> <td rowspan="2"></td> <td rowspan="2">.13</td>	5/8"	1.06	4	TNEC43EI4STACME...	.085	.25	.26		.13	
			4	TNEC54EI4STACME...	.085					

On Edge inserts are suited to existing toolholders on the market.

Stub ACME (con't)

MEGA/LINE

External

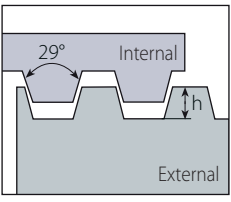

Defined by: ANSI B1.8:1988
Tolerance class: 2G

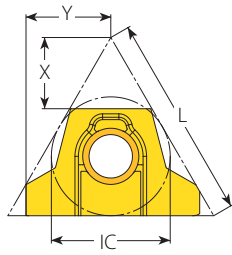
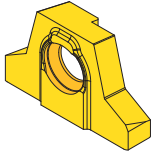
Mega Line

External



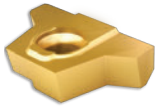

Insert Size		Pitch	Ordering Code	EDP No.	Dimensions inch			Number of Passes	
IC	L inch	TPI	RH	VKX	h min	X	Y	0.003inch–Min. Depth of Cut (On radius)	0.006inch–Max. Depth of Cut (On radius)
5/8" MG	1.06	1	5MGER1STACME...	42513	.310	.37	.45	113	53

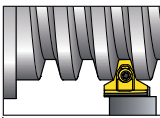
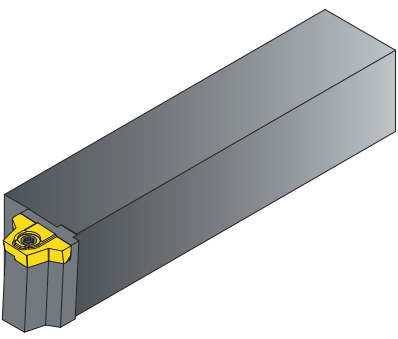
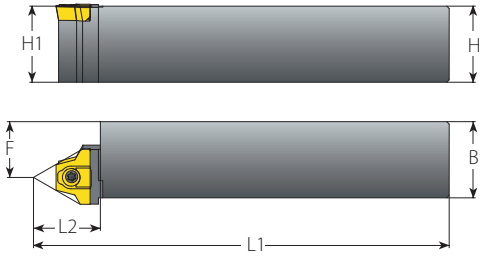
External Toolholders for Stub ACME





MEGA/LINE

External							Spare Parts		
Insert	Ordering Code	EDP No.	Dimensions inch			Thread Diameter Range (Min.-Max.)			
	RH		H=B=H1	F	L1	L2	Insert Screw	Torx Key	
5MGER1STACME...	NL100-5MG1STACME	66403	1.00	.650	6.1		(3.5"-5")-1STACME	S5MG	K6T
	NL125-5MG1STACME	66404	1.25	.930	6.9	.87			
	NL150-5MG1STACME	66405	1.50	1.24	8.1				

Recommended thread infeed method for Mega Line: Flank or Modified Flank 1°.

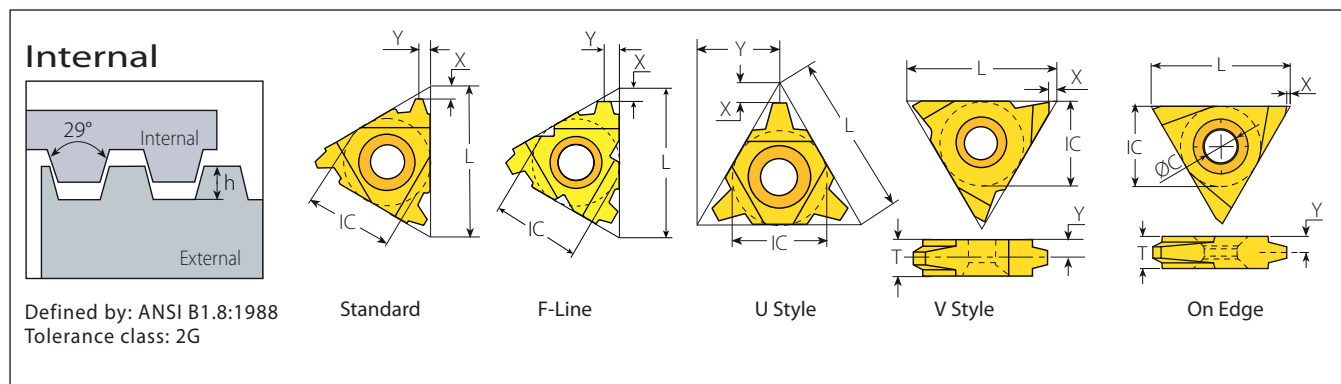
Stub ACME (con't)



Standard

IC	Insert Size		Pitch		Ordering Code		Dimensions inch			Anvil		Toolholder
	L inch	TPI	RH	LH	h min	X	Y	RH	LH			
1/4"	.43	16	2IR16STACME...	2IL16STACME...	.024	.04	.04	-	-	NVR..-2 (LH)		
		16	3IR16STACME...	3IL16STACME...	.024	.04	.04					
		14	3IR14STACME...	3IL14STACME...	.026	.04	.04					
3/8"	.63	12	3IR12STACME...	3IL12STACME...	.030	.04	.05	Y13	YE3	AVR..-3 (LH)		
		10	3IR10STACME...	3IL10STACME...	.040	.05	.05					
		8	3IR8STACME...	3IL8STACME...	.048	.06	.06					
		6	3IR6STACME...	3IL6STACME...	.060	.07	.07					
		6	4IR6STACME...	4IL6STACME...	.060	.07	.07					
1/2"	.87	5	4IR5STACME...	4IL5STACME...	.070	.08	.09	Y14	YE4	AVR..-4 (LH)		
		4	4IR4STACME...	4IL4STACME...	.085	.09	.09					
		6	4FIR6STACME...		.060	.07	.07					
1/2" F	.91	5	4FIR5STACME...		.070	.08	.09	Y14F		AVRC...-4F		
		4	4FIR4STACME...		.085	.09	.09					
5/8"	1.06	4	5IR4STACME...	5IL4STACME...	.085	.09	.09	Y15	YE5	AVR..-5 (LH)		
		3	5IR3STACME...	5IL3STACME...	.110	.11	.11					

U Style

IC	Insert Size		Pitch		Ordering Code		Dimensions inch			Anvil		Toolholder
	L inch	TPI	RH+LH		h min	X	Y	RH	LH			
1/2" U	.87	4	4UI4STACME...		.085	.10	.43	Y14U	YE4U	AVR..-4U (LH)		
		3	4UI3STACME...		.110	.13	.43					

V Style

IC	Insert Size		Pitch		Ordering Code		Dimensions inch			Toolholder
	L inch	TPI	RH	LH	h min	X	Y	T		
5/8" V	1.06	4	5VIR4STACME...	5VIL4STACME...	.085	.04	.13	.24	NVR..-5V (LH)	
		3	5VIR3STACME...	5VIL3STACME...	.110	.04	.13	.24		
		2	5VIR2STACME...	5VIL2STACME...	.160	.04	.17	.31		

On Edge

IC	Insert Size		Pitch		Ordering Code		Dimensions inch			
	L inch	TPI	RH		h min	T	Ø C	X	Y	
3/8"	.63	12	TNEC32EI12STACME...		.030	.13	.15	.04	.06	
		10	TNEC32EI10STACME...		.040					
		8	TNEC32EI8STACME...		.048					
1/2"	.87	12	TNEC43EI12STACME...		.030	.19	.20	.02	.09	
		10	TNEC43EI10STACME...		.040					
		8	TNEC43EI8STACME...		.048					
		6	TNEC43EI6STACME...		.060					
		4	TNEC43EI4STACME...		.085					
5/8"	1.06	4	TNEC54EI4STACME...		.085	.25	.26		.13	

On Edge inserts are suited to existing toolholders on the market.

Stub ACME (con't)

MEGA/LINE

Internal

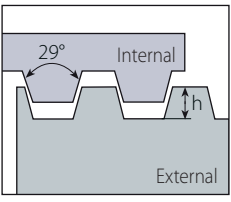

Defined by: ANSI B1.8:1988
Tolerance class: 2G

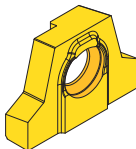

Mega Line

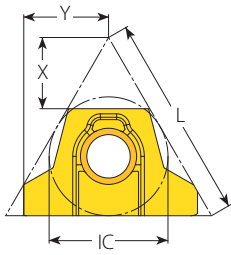

Internal



IC	L inch	Pitch TPI	Ordering Code RH	EDP No. VKX	Dimensions inch			Number of Passes	
					h min	X	Y	0.003inch–Min. Depth of Cut (On radius)	0.006inch–Max. Depth of Cut (On radius)
5/8" MG	1.06	1	5MGIR1STACME...	42512	.308	.37	.41	113	53

Internal Toolholders for Stub ACME

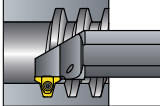
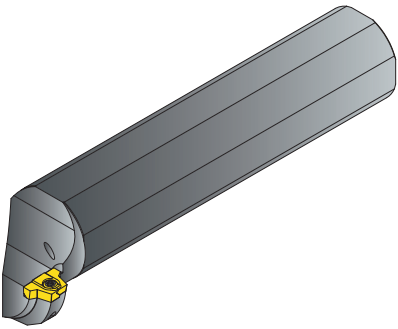
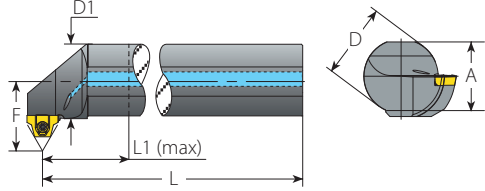
MEGA/LINE

Internal

Insert	Ordering Code	EDP No.	Dimensions							Min. Bore Dia.	Thread Diameter Range (Min.-Max.)		Spare Parts	
			A	L	L1 (max)	D	D1	F	inch		Short Chip Material	Long Chip Material	Insert Screw	Torx Key
5MGIR1STACME...	NVRC150-5MG1STACME	66406	1.42	9.15	4	1.5	1.49	1.63	2.9	(3.5"-5")-1STACME	(3.5"-5")-1STACME	S5MG	K6T	
	NVRC200-5MG1STACME	66407	1.81	10.15	5	2	1.99	1.83	2.9	(3.5"-5")-1STACME	(4.0"-5")-1STACME			
	NVRC250-5MG1STACME	66408	2.28	11.10	6	2.5	2.49	2.03	3.4	(4.0"-5")-1STACME	(4.5"-5")-1STACME			

Recommended thread infeed method for Mega Line: Flank or Modified Flank 1°.

Stub ACME (con't)

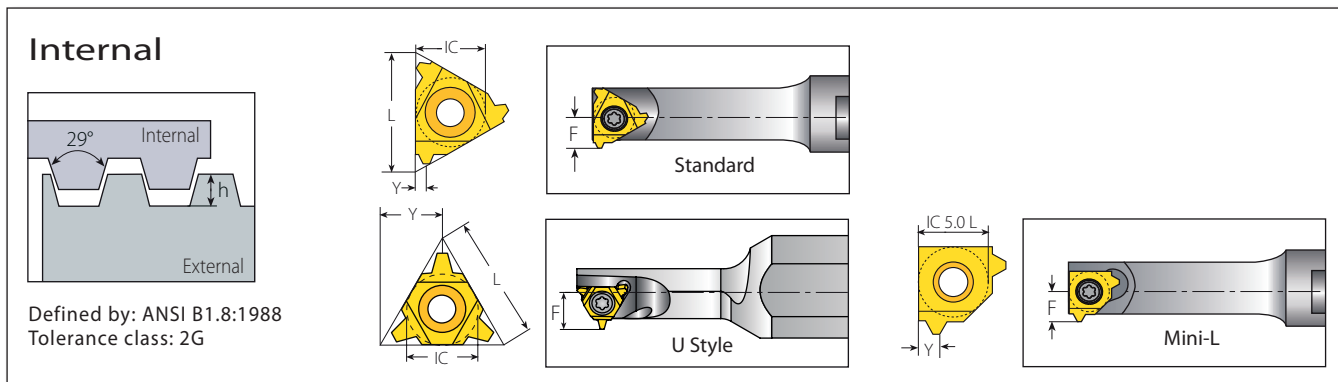

Mini-3 Standard



Insert Size		Pitch	Ordering Code		Dimensions inch			Min. Bore Dia.	Toolholder
IC mm	L inch	TPI	RH	LH	h min	Y	F	inch	
5.0	.31	16	5.0KIR16STACME...	5.0KIL16STACME...	.024	.03	.19	.31	.NVR...-5.0K (LH)
6.0	.39	12	6.0KIR12STACME...	6.0KIL12STACME...	.030	.05	.20	.39	.NVR...-6.0K (LH)

Mini-3 U Style



Insert Size		Pitch	Ordering Code	Dimensions inch			Min. Bore Dia.	Toolholder
IC mm	L inch	TPI	RH+LH	h min	Y	F	inch	
5.0U	.31	14	5.0KUI14STACME...	.026	.16	.23	.35	
		12	5.0KUI12STACME...	.030		.22		
		10	5.0KUI10STACME...	.040		.22		

Mini-L



Insert Size		Pitch	Ordering Code		Dimensions inch			Min. Bore Dia.	Toolholder
IC mm	TPI		RH	LH	h min	Y	F	inch	
5.0L	12		5LKIR12STACME...	5LKIL12STACME...	.030	.05	.17	.31	.NVR...-5LK (LH)

UNJ - UNJC, UNJF, UNJEF, UNJS

External

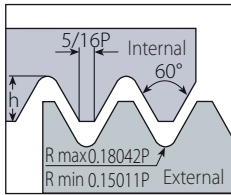

Defined by: MIL-S-8879C
Tolerance class: 3A/3B

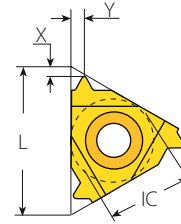

Standard

Standard

Insert Size		Pitch	Ordering Code		Dimensions inch			Anvil		Toolholder
IC	L inch	TPI	RH	LH	h min	X	Y	RH	LH	
1/4"	.43	48	2ER48UNJ...	2EL48UNJ...	.012	.02	.02	-	-	NL...-2 (LH)
		44	2ER44UNJ...	2EL44UNJ...	.013	.02	.02			
		40	2ER40UNJ...	2EL40UNJ...	.015	.02	.02			
		36	2ER36UNJ...	2EL36UNJ...	.016	.02	.02			
		32	2ER32UNJ...	2EL32UNJ...	.018	.02	.03			
		28	2ER28UNJ...	2EL28UNJ...	.020	.03	.03			
		24	2ER24UNJ...	2EL24UNJ...	.024	.03	.03			
		20	2ER20UNJ...	2EL20UNJ...	.029	.03	.04			
		18	2ER18UNJ...	2EL18UNJ...	.032	.03	.04			
		16	2ER16UNJ...	2EL16UNJ...	.036	.04	.04			
		14	2ER14UNJ...	2EL14UNJ...	.041	.04	.05			
		3/8"	.63	48	3ER48UNJ...	3EL48UNJ...	.012			
44	3ER44UNJ...			3EL44UNJ...	.013	.02	.02			
40	3ER40UNJ...			3EL40UNJ...	.015	.02	.02			
36	3ER36UNJ...			3EL36UNJ...	.016	.02	.02			
32	3ER32UNJ...			3EL32UNJ...	.018	.02	.03			
28	3ER28UNJ...			3EL28UNJ...	.020	.03	.03			
24	3ER24UNJ...			3EL24UNJ...	.024	.03	.03			
20	3ER20UNJ...			3EL20UNJ...	.029	.03	.04			
18	3ER18UNJ...			3EL18UNJ...	.032	.03	.04			
16	3ER16UNJ...			3EL16UNJ...	.036	.04	.04			
14	3ER14UNJ...			3EL14UNJ...	.041	.04	.05			
13	3ER13UNJ...			3EL13UNJ...	.044	.04	.05			
12	3ER12UNJ...			3EL12UNJ...	.048	.04	.05			
11	3ER11UNJ...			3EL11UNJ...	.052	.05	.06			
10	3ER10UNJ...			3EL10UNJ...	.058	.05	.06			
9	3ER9UNJ...			3EL9UNJ...	.064	.05	.07			
8	3ER8UNJ...	3EL8UNJ...	.072	.05	.06					



UNJ - UNJC, UNJF, UNJEF, UNJS (con't)

External

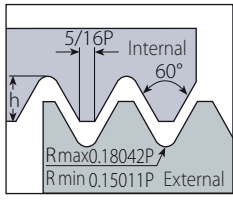

Defined by: MIL-S-8879C
Tolerance class: 3A/3B

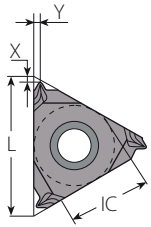

SCB
Sintered
Chipbreaker

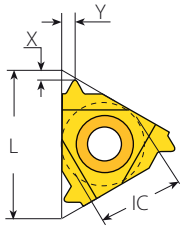

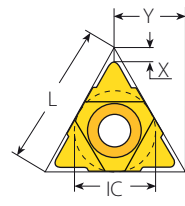

Standard



U Style

Standard

Insert Size		Pitch	Ordering Code		Dimensions inch			Anvil		Toolholder
IC	L inch	TPI	RH	LH	h min	X	Y	RH	LH	
 3/8" SCB	.63	36	3JER36UNJ...		.016	.05	.02	YE3	-	AL..-3
		32	3JER32UNJ...		.018	.05	.02			
		28	3JER28UNJ...		.020	.03	.03			
		24	3JER24UNJ...		.024	.03	.03			
		20	3JER20UNJ...		.029	.03	.03			
		18	3JER18UNJ...		.032	.03	.03			
		16	3JER16UNJ...		.036	.03	.03			
		14	3JER14UNJ...		.041	.05	.06			
		12	3JER12UNJ...		.048	.05	.06			
		10	3JER10UNJ...		.058	.05	.06			
 1/2"	.87	7	4ER7UNJ...	4EL7UNJ...	.082	.07	.09	YE4	YI4	AL..-4 (LH)
		6	4ER6UNJ...	4EL6UNJ...	.096	.07	.09			
		5	4ER5UNJ...	4EL5UNJ...	.115	.07	.10			
 5/8"	1.06	4.5	5ER4.5UNJ...	5EL4.5UNJ...	.128	.08	.11	YE5	YI5	AL..-5 (LH)
		4	5ER4UNJ...	5EL4UNJ...	.144	.09	.12			

U Style



Insert Size		Pitch	Ordering Code		Dimensions inch			Anvil		Toolholder
IC	L inch	TPI	RH+LH		h min	X	Y	RH	LH	
1/2"U	.87	4.5	4UE4.5UNJ...		.128	.08	.43	YE4U	YI4U	AL..-4U (LH)
		4	4UE4UNJ...		.144	.09	.43			

UNJ - UNJC, UNJF, UNJEF, UNJS (con't)

Internal

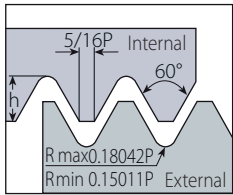

Defined by: MIL-S-8879C
Tolerance class: 3A/3B

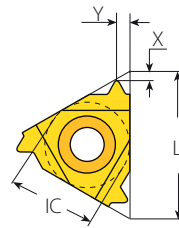

Standard

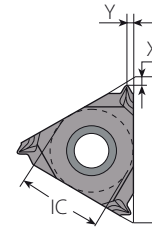

SCB
Sintered
Chipbreaker

Standard

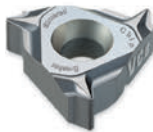

SCB

Insert Size		Pitch	Ordering Code		Dimensions inch			Anvil		Toolholder
IC	L inch	TPI	RH	LH	h min	X	Y	RH	LH	
1/4"	.43	48	2IR48UNJ...	2IL48UNJ...	.011	.02	.02	-	-	NVR..-2 (LH)
		44	2IR44UNJ...	2IL44UNJ...	.012	.02	.02			
		40	2IR40UNJ...	2IL40UNJ...	.013	.02	.02			
		36	2IR36UNJ...	2IL36UNJ...	.015	.02	.02			
		32	2IR32UNJ...	2IL32UNJ...	.017	.02	.03			
		28	2IR28UNJ...	2IL28UNJ...	.019	.03	.03			
		24	2IR24UNJ...	2IL24UNJ...	.022	.03	.03			
		20	2IR20UNJ...	2IL20UNJ...	.026	.03	.04			
		18	2IR18UNJ...	2IL18UNJ...	.029	.03	.04			
		16	2IR16UNJ...	2IL16UNJ...	.033	.04	.04			
1/4" SCB	.43	36	2JIR36UNJ...		.015	.04	.02	-	-	NVR..-2
		32	2JIR32UNJ...		.017	.05	.02			
		28	2JIR28UNJ...		.019	.02	.03			
		24	2JIR24UNJ...		.022	.02	.03			
		20	2JIR20UNJ...		.026	.02	.03			
		18	2JIR18UNJ...		.029	.02	.03			
		16	2JIR16UNJ...		.033	.02	.03			
		14	2JIR14UNJ...		.037	.02	.03			

UNJ - UNJC, UNJF, UNJEF, UNJS (con't)

Internal

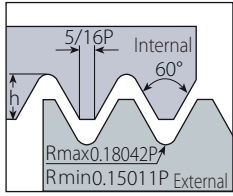

Defined by: MIL-S-8879C
Tolerance class: 3A/3B

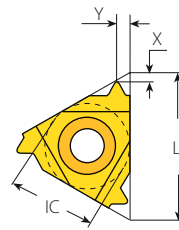

Standard

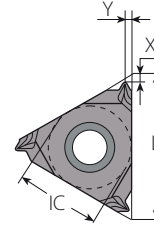

SCB
Sintered
Chipbreaker

Standard

Insert Size		Pitch	Ordering Code		Dimensions inch			Anvil		Toolholder
IC	L inch	TPI	RH	LH	h min	X	Y	RH	LH	
3/8"	.63	48	3IR48UNJ...	3IL48UNJ...	.011	.02	.02	Y13	YE3	AVR..-3 (LH)
		44	3IR44UNJ...	3IL44UNJ...	.012	.02	.02			
		40	3IR40UNJ...	3IL40UNJ...	.013	.02	.02			
		36	3IR36UNJ...	3IL36UNJ...	.015	.02	.02			
		32	3IR32UNJ...	3IL32UNJ...	.017	.02	.03			
		28	3IR28UNJ...	3IL28UNJ...	.019	.03	.03			
		24	3IR24UNJ...	3IL24UNJ...	.022	.03	.03			
		20	3IR20UNJ...	3IL20UNJ...	.026	.03	.04			
		18	3IR18UNJ...	3IL18UNJ...	.029	.03	.04			
		16	3IR16UNJ...	3IL16UNJ...	.033	.04	.04			
		14	3IR14UNJ...	3IL14UNJ...	.037	.04	.05			
		13	3IR13UNJ...	3IL13UNJ...	.040	.04	.05			
		12	3IR12UNJ...	3IL12UNJ...	.044	.04	.05			
		11	3IR11UNJ...	3IL11UNJ...	.048	.05	.06			
10	3IR10UNJ...	3IL10UNJ...	.052	.05	.06					
9	3IR9UNJ...	3IL9UNJ...	.058	.05	.07					
8	3IR8UNJ...	3IL8UNJ...	.065	.05	.06					
3/8" SCB	.63	28	3JIR28UNJ...		.019	.02	.03	Y13	-	AVR..-3
		24	3JIR24UNJ...		.022	.02	.03			
		20	3JIR20UNJ...		.026	.02	.03			
		18	3JIR18UNJ...		.029	.02	.03			
		16	3JIR16UNJ...		.033	.02	.03			
		14	3JIR14UNJ...		.037	.04	.06			
		12	3JIR12UNJ...		.044	.04	.06			
		10	3JIR10UNJ...		.052	.04	.06			
8	3JIR8UNJ...		.065	.04	.06					
1/2"	.87	7	4IR7UNJ...	4IL7UNJ...	.075	.07	.09	Y14	YE4	AVR..-4 (LH)
		6	4IR6UNJ...	4IL6UNJ...	.087	.07	.09			
		5	4IR5UNJ...	4IL5UNJ...	.105	.07	.10			
5/8"	1.06	4.5	5IR4.5UNJ...	5IL4.5UNJ...	.116	.08	.11	Y15	YE5	AVR..-5 (LH)
		4	5IR4UNJ...	5IL4UNJ...	.131	.09	.09			

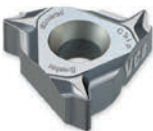

SCB



UNJ - UNJC, UNJF, UNJEF, UNJS (con't)

Internal

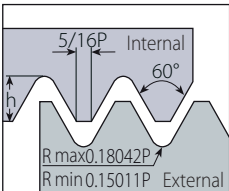
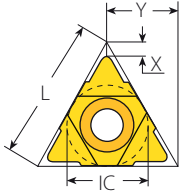
Defined by: MIL-S-8879C
Tolerance class: 3A/3B

U Style

U Style



Insert Size		Pitch	Ordering Code		Dimensions inch			Anvil		Toolholder
IC	L inch	TPI	RH+LH		h min	X	Y	RH	LH	
1/2"U	.87	4.5	4UI4.5UNJ...		.116	.08	.43	Y14U	YE4U	AVR...-4U (LH)
		4	4UI4UNJ...		.131	.09	.43			

UNJ - UNJC, UNJF, UNJEF, UNJS

MINIPRO

Internal

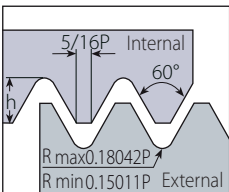
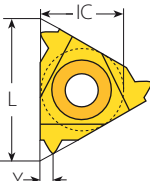
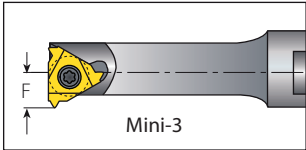
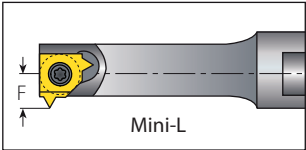
Defined by: MIL-S-8879C
Tolerance class: 3A/3B

Mini-3 Standard



Insert Size		Pitch	Ordering Code		Dimensions inch			Min. Bore Dia.		Toolholder
IC mm	L inch	TPI	RH	LH	h min	Y	F	inch		
6.0	.39	20	6.0KIR20UNJ...	6.0KIL20UNJ...	.026	.04	.19	.39	.NVR...-6.0K (LH)	

Mini-L



Insert Size		Pitch	Ordering Code		Dimensions inch			Min. Bore Dia.		Toolholder
IC mm	TPI	RH	LH	h min	Y	F	inch			
5.0L	32	5LKIR32UNJ...	5LKIL32UNJ...	.017	.02	.15	.30	.NVR...-5LK (LH)		
	28	5LKIR28UNJ...	5LKIL28UNJ...	.019	.02	.16	.30			
	24	5LKIR24UNJ...	5LKIL24UNJ...	.022	.03	.17	.30			
	20	5LKIR20UNJ...	5LKIL20UNJ...	.026	.04	.17	.30			
	18	5LKIR18UNJ...	5LKIL18UNJ...	.029	.04	.17	.31			
	16	5LKIR16UNJ...	5LKIL16UNJ...	.033	.04	.17	.31			
	14	5LKIR14UNJ...	5LKIL14UNJ...	.037	.04	.18	.31			

MJ

External

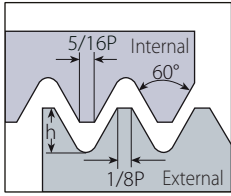

Defined by: ISO 5855
Tolerance class: 4h/6h-4H/5H

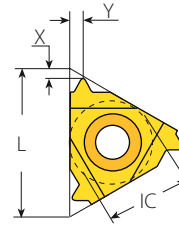

Standard

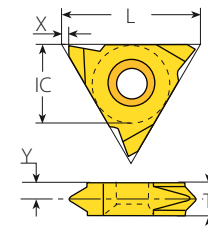

Slim Throat

Standard



Insert Size		Pitch	Ordering Code		Dimensions inch			Anvil		Toolholder
IC	L inch	mm	RH	LH	h min	X	Y	RH	LH	
1/4"	.43	1.0	2ER1.0MJ...	2EL1.0MJ...	.023	.03	.03	-	-	NL...-2 (LH)
		1.25	2ER1.25MJ...	2EL1.25MJ...	.028	.03	.04			
		1.5	2ER1.5MJ...	2EL1.5MJ...	.034	.03	.04			
3/8"	.63	0.7	3ER0.7MJ...	3EL0.7MJ...	.016	.02	.02	YE3	YI3	AL...-3 (LH)
		0.8	3ER0.8MJ...	3EL0.8MJ...	.018	.03	.03			
		1.0	3ER1.0MJ...	3EL1.0MJ...	.023	.03	.03			
		1.25	3ER1.25MJ...	3EL1.25MJ...	.028	.03	.04			
		1.5	3ER1.5MJ...	3EL1.5MJ...	.034	.03	.04			
		2.0	3ER2.0MJ...	3EL2.0MJ...	.045	.04	.05			
		2.5	3ER2.5MJ...	3EL2.5MJ...	.059	.04	.06			
		3.0	3ER3.0MJ...	3EL3.0MJ...	.068	.05	.06			

Slim Throat



Insert Size		Pitch	Ordering Code		Dimensions inch				Toolholder
IC	L inch	mm	RH	LH	h min	X	Y	T	
1/4"V	.43	0.7	2VER0.7MJ...	2VEL0.7MJ...	.016	.03	.10	.13	NL...-2V (LH)
		0.8	2VER0.8MJ...	2VEL0.8MJ...	.017	.03	.10	.13	
		0.9	2VER0.9MJ...	2VEL0.9MJ...	.021	.03	.10	.13	
		1.0	2VER1.0MJ...	2VEL1.0MJ...	.023	.03	.10	.13	
		1.25	2VER1.25MJ...	2VEL1.25MJ...	.028	.03	.09	.13	
		1.5	2VER1.5MJ...	2VEL1.5MJ...	.034	.03	.09	.13	

MJ (con't)

Internal

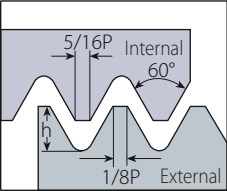

Defined by: ISO 5855
Tolerance class: 4h/6h-4H/5H

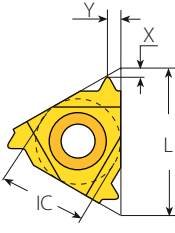

Standard

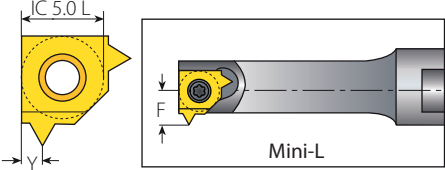

Mini-L

Standard



Insert Size		Pitch	Ordering Code		Dimensions inch			Anvil		Toolholder
IC mm	L inch	mm	RH	LH	h min	X	Y	RH	LH	
1/4"	.43	1.0	2IR1.0MJ...	2IL1.0MJ...	.019	.02	.03	-	-	NVR..-2 (LH)
		1.25	2IR1.25MJ...	2IL1.25MJ...	.024	.03	.04			
		1.5	2IR1.5MJ...	2IL1.5MJ...	.029	.03	.04			
		2.0	2IR2.0MJ...	2IL2.0MJ...	.038	.03	.04			
3/8"	.63	0.75	3IR0.75MJ...	3IL0.75MJ...	.015	.02	.02	Y13	YE3	AVR.-3 (LH)
		0.8	3IR0.8MJ...	3IL0.8MJ...	.017	.03	.03			
		1.0	3IR1.0MJ...	3IL1.0MJ...	.019	.02	.03			
		1.25	3IR1.25MJ...	3IL1.25MJ...	.024	.03	.04			
		1.5	3IR1.5MJ...	3IL1.5MJ...	.029	.03	.04			
		2.0	3IR2.0MJ...	3IL2.0MJ...	.038	.03	.05			
		2.5	3IR2.5MJ...	3IL2.5MJ...	.048	.04	.06			
3.0	3IR3.0MJ...	3IL3.0MJ...	.057	.05	.06					

Mini - L



MINIPRO

Insert Size		Pitch	Ordering Code		Dimensions inch			Min. Bore Dia.	Toolholder
IC mm		mm	RH	LH	h min	Y	F	inch	
5.0L		1.0	5LKIR1.0MJ...	5LKIL1.0MJ...	.019	.03	.16	.30	.NVR...-5LK (LH)
		1.25	5LKIR1.25MJ...	5LKIL1.25MJ...	.024	.04	.17	.30	
		1.5	5LKIR1.50MJ...	5LKIL1.50MJ...	.029	.04	.17	.30	

American Buttress

External

Defined by: ANSI B1.9.1973
Tolerance class: Class 2

Standard

F-Line

U Style

V Style



Standard

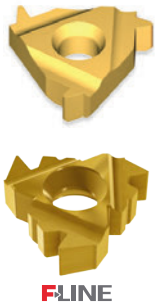

Insert Size		Pitch	Ordering Code		Dimensions inch			Anvil		Toolholder
IC	L inch	TPI	RH	LH	h min	X	Y	RH	LH	
1/4"	.43	20	2ER20ABUT...	2EL20ABUT...	.033	.04	.06	-	-	NL..-2 (LH)
		16	2ER16ABUT...	2EL16ABUT...	.041	.05	.07	-	-	NL..-2 (LH)
3/8"	.63	20	3ER20ABUT...	3EL20ABUT...	.033	.04	.06	YE3	YI3	AL..-3 (LH)
		16	3ER16ABUT...	3EL16ABUT...	.041	.05	.07			
		12	3ER12ABUT...	3EL12ABUT...	.055	.06	.08			
1/2"	.87	10	3ER10ABUT...	3EL10ABUT...	.066	.06	.09	YE4	YI4	AL..-4 (LH)
		8	4ER8ABUT...	4EL8ABUT...	.083	.08	.13			
1/2"F	.91	8	4FER8ABUT...	4EL6ABUT...	.083	.08	.13	YE4F		AL...-4F
		6	4FER6ABUT...		.110	.09	.14			

U Style



Insert Size		Pitch	Ordering Code		Dimensions inch			Anvil		Toolholder
IC	L inch	TPI	RH	LH	h min	X	Y	RH	LH	
1/2"U	.87	4	4UER4ABUT...	4UEL4ABUT...	.166	.09	.39	YE4U-BUT4	YI4U-BUT4	AL..-4U (LH)
5/8"U	1.06	3	5UER3ABUT...	5UEL3ABUT...	.221	.12	.48	YE5U-BUT3	YI5U-BUT3	AL..-5U (LH)

V Style



Insert Size		Pitch	Ordering Code		Dimensions inch			T	Toolholder
IC	L inch	TPI	RH	LH	h min	X	Y		
5/8"V	1.06	4	5VER4ABUT...	5VEL4ABUT...	.166	.02	.07	.24	NL..-5V-6 (LH)
		3	5VER3ABUT...	5VEL3ABUT...	.221	.02	.09	.31	NL..-5V-8 (LH)
		2.5	5VER2.5ABUT...	5VEL2.5ABUT...	.265	.02	.11	.39	NL..-5V-10ABUT (LH)

American Buttress (con't)

MEGA/LINE

External

Defined by: ANSI B1.9.1973
Tolerance class: Class 2

Mega Line

External



Insert Size		Pitch	Ordering Code	EDP No.	Dimensions inch			Number of Passes	
IC	L inch	TPI	RH	VKX	h min	X	Y	0.003inch–Min. Depth of Cut (On radius)	0.006inch–Max. Depth of Cut (On radius)
5/8" MG	1.06	2	5MGER2ABUT...	42503	.332	.06	.61	120	56
		1.5	5MGER1.5ABUT...	42502	.442	.07		160	75

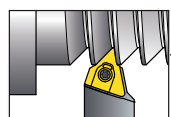

External Toolholders for American Buttress **MEGA**/LINE

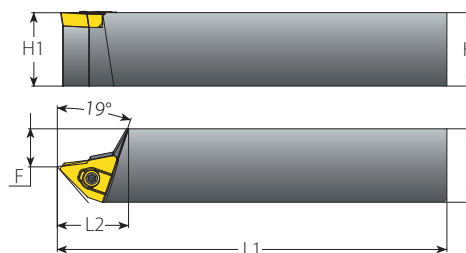
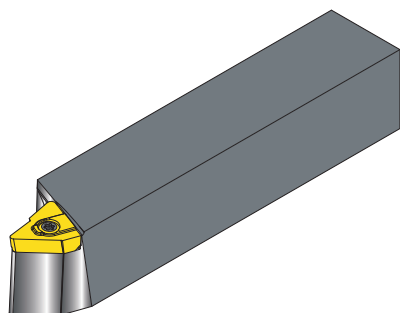

External

Insert	Ordering Code	EDP No.	Dimensions inch			Thread Diameter Range (Min.-Max.)	Spare Parts	
			H=B=H1	F	L1		L2	
5MGER2ABUT...	NL100-5MG2ABUT	66479	1.00	.37	5.9	7"-24")-2ABUT	S5MG	Torx Key
	NL125-5MG2ABUT	66480	1.25	.65	6.7			
	NL150-5MG2ABUT	66481	1.50	.96	7.9			
5MGER1.5ABUT...	NL100-5MG1.5ABUT	66482	1.00	.37	5.9	11"-24")-1.5ABUT	S5MG	K6T
	NL125-5MG1.5ABUT	66483	1.25	.65	6.7			
	NL150-5MG1.5ABUT	66484	1.50	.96	7.9			

Recommended thread infeed method for Mega Line: Flank or Modified Flank 1°.

American Buttress (con't)

Internal

Defined by: ANSI B1.9.1973
Tolerance class: Class 2

Standard

F-Line

U Style

V Style

Standard



Insert Size		Pitch	Ordering Code		Dimensions inch			Anvil		Toolholder
IC	L inch	TPI	RH	LH	h min	X	Y	RH	LH	
1/4"	.43	20	2IR20ABUT...	2IL20ABUT...	.033	.04	.06	-	-	NVR..-2 (LH)
		16	2IR16ABUT...	2IL16ABUT...	.041	.05	.07	-	-	NVR..-2 (LH)
3/8"	.63	20	3IR20ABUT...	3IL20ABUT...	.033	.04	.06	YI3	YE3	AVR..-3 (LH)
		16	3IR16ABUT...	3IL16ABUT...	.041	.05	.07			
		12	3IR12ABUT...	3IL12ABUT...	.055	.06	.08			
1/2"	.87	10	3IR10ABUT...	3IL10ABUT...	.066	.06	.09	YI4	YE4	AVR..-4 (LH)
		8	4IR8ABUT...	4IL8ABUT...	.083	.08	.13			
1/2" F	.91	6	4IR6ABUT...	4IL6ABUT...	.110	.09	.14	YI4F		AVRC...-4F
		8	4FIR8ABUT...		.083	.08	.13			



U Style



Insert Size		Pitch	Ordering Code		Dimensions inch			Anvil		Toolholder
IC	L inch	TPI	RH	LH	h min	X	Y	RH	LH	
1/2"U	.87	4	4UIR4ABUT...	4UIL4ABUT...	.166	.09	.39	YI4U-4B	YE4U-4B	AVR..-4U (LH)
5/8"U	1.06	3	5UIR3ABUT...	5UIL3ABUT...	.221	.12	.48	YI5U-3B	YE5U-3B	AVR..-5U (LH)

V Style



Insert Size		Pitch	Ordering Code		Dimensions inch			Toolholder	
IC	L inch	TPI	RH	LH	h min	X	Y		T
5/8"V	1.06	4	5VIR4ABUT...	5VIL4ABUT...	.166	.02	.07	.24	NVR..-5V (LH)
		3	5VIR3ABUT...	5VIL3ABUT...	.221	.02	.09	.31	
		2.5	5VIR2.5ABUT...	5VIL2.5ABUT...	.265	.02	.11	.39	

American Buttress (con't)

MEGA/LINE

Internal

Defined by: ANSI B1.9.1973
Tolerance class: Class 2

Mega Line

Internal



IC	L inch	TPI	RH	VKX	h min	X	Y	Number of Passes	
								0.003inch–Min. Depth of Cut (On radius)	0.006inch–Max. Depth of Cut (On radius)
5/8" MG	1.06	2	5MGIR2ABUT	42501	.352	.06	.63	128	60
		1.5	5MGIR1.5ABUT	42500	.469	.07		170	79

Internal Toolholders for American Buttress

Insert	Ordering Code	EDP No.	Dimensions inch							Min. Bore Dia.	Thread Diameter Range (Min.-Max.)		Spare Parts	
			A	L	L1 (max)	D	D1	F	inch		Short Chip Material	Long Chip Material	Insert Screw	Torx Key
5MGIR2ABUT...	NVRC150-5MG2ABUT	66485	1.42	9.05	4	1.5	1.49	1.38	6.4	(7"-16")-2ABUT	(7"-16")-2ABUT	S5MG	K6T	
	NVRC200-5MG2ABUT	66486	1.81	10.05	5	2.0	1.99	1.56						
	NVRC250-5MG2ABUT	66487	2.28	11.04	6	2.5	2.49	1.81						
5MGIR1.5ABUT...	NVRC150-5MG1.5ABUT	66488	1.42	9.07	4	1.5	1.49	1.38	10.2	(11"-22")-1.5ABUT	(11"-22")-1.5ABUT	S5MG	K6T	
	NVRC200-5MG1.5ABUT	66489	1.81	10.05	5	2.0	1.99	1.56						
	NVRC250-5MG1.5ABUT	66490	2.28	11.04	6	2.5	2.49	1.81						

Recommended thread infeed method for Mega Line: Flank or Modified Flank 1°.

British Buttress

External

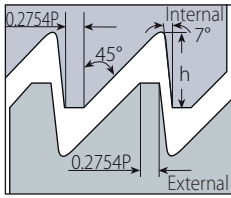

Defined by: B.S. 1657: 1950
Tolerance class: Medium Class

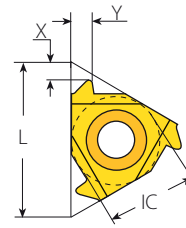

Standard

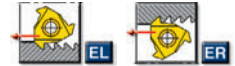

Standard



IC	Insert Size		Pitch		Ordering Code		Dimensions inch			Anvil		Toolholder
	L inch	TPI	RH	LH	h min	X	Y	RH	LH			
3/8"	.63	16	3ER16BBUT...	3EL16BBUT...	.031	.04	.06	YE3	YI3	AL...-3 (LH)		
		12	3ER12BBUT...	3EL12BBUT...	.042	.06	.08					
		10	3ER10BBUT...	3EL10BBUT...	.050	.06	.09					
		8	3ER8BBUT...	3EL8BBUT...	.063	.06	.10					
1/2"	.87	8	4ER8BBUT...	4EL8BBUT...	.063	.06	.10	YE4	YI4	AL...-4 (LH)		

British Buttress

Internal

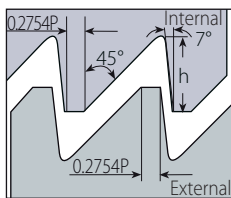

Defined by: B.S. 1657: 1950
Tolerance class: Medium Class

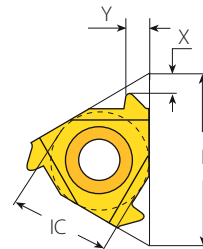

Standard



Standard



IC	Insert Size		Pitch		Ordering Code		Dimensions inch			Anvil		Toolholder
	L inch	TPI	RH	LH	h min	X	Y	RH	LH			
3/8"	.63	16	3IR16BBUT...	3IL16BBUT...	.031	.04	.06	YI3	YE3	AVR...-3 (LH)		
		12	3IR12BBUT...	3IL12BBUT...	.042	.06	.08					
		10	3IR10BBUT...	3IL10BBUT...	.050	.06	.09					
		8	3IR8BBUT...	3IL8BBUT...	.063	.06	.10					
1/2"	.87	8	4IR8BBUT...	4IL8BBUT...	.063	.06	.10	YI4	YE4	AVR...-4 (LH)		

Metric Buttress (Sägewinde)

External

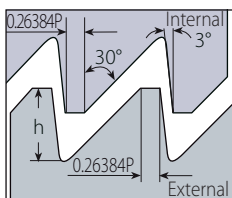

Defined by: DIN 513
Tolerance class: Medium Class

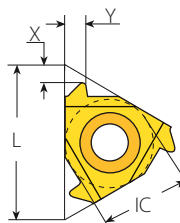

Standard

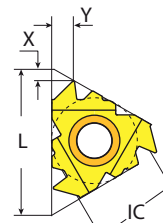

F-Line

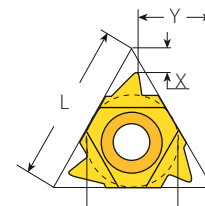

U Style

Standard - External



F.LINE

Insert Size		Pitch	Ordering Code		Dimensions inch			Anvil		Toolholder
IC	L inch	mm	RH	LH	h min	X	Y	RH	LH	
3/8"	.63	2.0	3ER2.0SAGE...	3EL2.0SAGE...	.069	.06	.08	YE3	YI3	AL...-3 (LH)
		2.0	4ER2.0SAGE...	4EL2.0SAGE...	.069	.06	.08			
1/2"	.87	3.0	4ER3.0SAGE...	4EL3.0SAGE...	.102	.07	.10	YE4	YI4	AL...-4 (LH)
		4.0	4ER4.0SAGE...	4EL4.0SAGE...	.140	.07	.12			
1/2"F	.91	3.0	4FER3.0SAGE...		.102	.07	.10	YE4F		AL...-4F
		4.0	4FER4.0SAGE...		.140	.07	.12			
5/8"	1.06	4.0	5ER4.0SAGE...	5EL4.0SAGE...	.140	.07	.13	YE5 082/038	YI5 082/039	AL...-5 (LH)

U Style - External



Insert Size		Pitch	Ordering Code		Dimensions inch			Anvil		Toolholder
IC	L inch	mm	RH	LH	h min	X	Y	RH	LH	
1/2"U	.87	5.0	4UER5.0SAGE...	4UEL5.0SAGE...	.174	.05	.41	YE4U-SAGE5	YI4U-SAGE5	AL...-4U (LH)
		6.0	4UER6.0SAGE...	4UEL6.0SAGE...	.208	.05	.40	YE4U-SAGE6	YI4U-SAGE6	

Metric Buttress (Sägengewinde) (con't)

MEGALINE

External

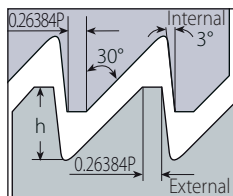

Defined by: DIN 513
Tolerance class: Medium Class

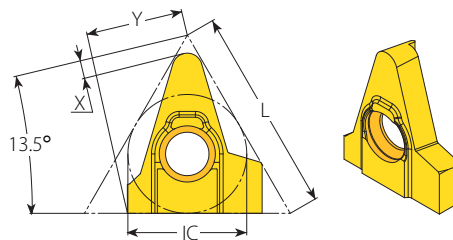

Mega Line

External

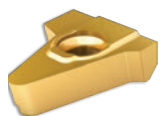

Insert Size		Pitch	Ordering Code	EDP No.	Dimensions inch			Number of Passes	
IC	L inch	mm	RH	VKX	h min	X	Y	0.003inch-Min. Depth of Cut (On radius)	0.006inch-Max. Depth of Cut (On radius)
5/8" MG	1.06	10.0	5MGER10.OSAGE...	42522	.342	.06	.52	124	58
		12.0	5MGER12.OSAGE...	42523	.410	.07		149	69
		14.0	5MGER14.OSAGE...	42524	.478	.08		174	81
		16.0	5MGER16.OSAGE...	42525	.547	.13		198	93
		20.0	5MGER20.OSAGE...	42526	.983	.10		248	116

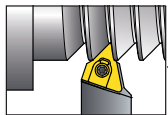

Recommended thread infeed method for Mega Line: Flank or Modified Flank 1°.

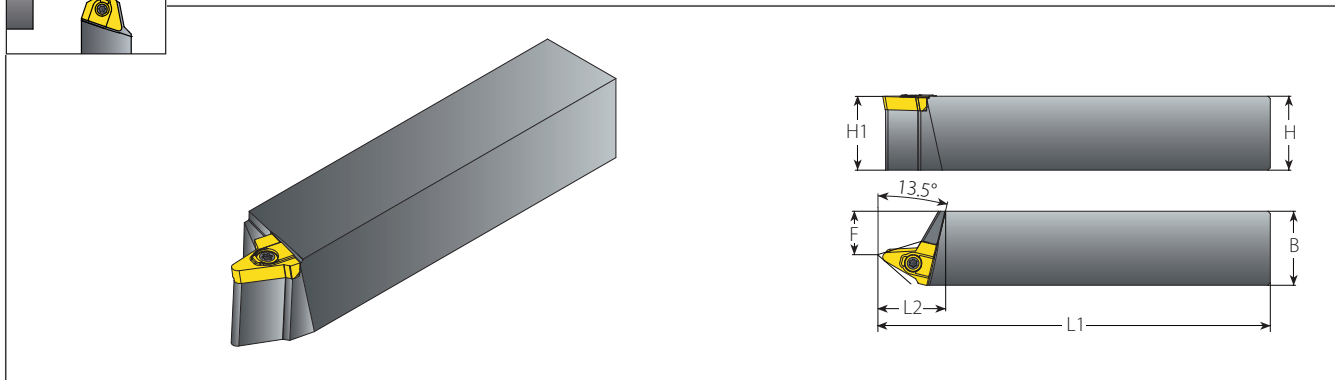

External Toolholders for Metric Buttress (Sägewinde) **MEGA/LINE**



External

Insert	Ordering Code	EDP No.	Dimensions inch			Thread Diameter Range (Min.-Max.)	Spare Parts		
			H=B=H1	F	L1		L2	 Insert Screw	 Torx Key
5MGER10.0SAGE...	NL100-5MG10SAGE	66341	1.00	.46	5.9	1.2	(S65-80)x10	S5MG	K6T
	NL125-5MG10SAGE	66342	1.25	.74	6.7				
	NL150-5MG10SAGE	66343	1.50	1.06	7.9				
5MGER12.0SAGE...	NL100-5MG12SAGE	66344	1.00	.46	5.9	1.2	(S85-146)x12		
	NL125-5MG12SAGE	66364	1.25	.74	6.7				
	NL150-5MG12SAGE	66365	1.50	1.06	7.9				
5MGER14.0SAGE...	NL100-5MG14SAGE	66366	1.00	.46	5.9	1.2	(S115-145)x14		
	NL125-5MG14SAGE	66367	1.25	.74	6.7				
	NL150-5MG14SAGE	66368	1.50	1.06	7.9				
5MGER16.0SAGE...	NL100-5MG16SAGE	66382	1.00	.46	5.9	1.2	(S150-175)x16		
	NL125-5MG16SAGE	66383	1.25	.74	6.7				
	NL150-5MG16SAGE	66384	1.50	1.06	7.9				
5MGER20.0SAGE...	NL100-5MG20SAGE	66385	1.00	.46	5.9	1.2	(S210-230)x20		
	NL125-5MG20SAGE	66387	1.25	.74	6.7				
	NL150-5MG20SAGE	66388	1.50	1.06	7.9				

Recommended thread infeed method for Mega Line: Flank or Modified Flank 1°.

Metric Buttress (Sägewinde) (con't)

Internal

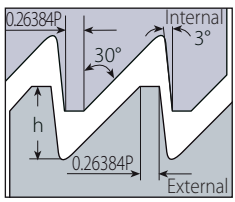

Defined by: DIN 513
Tolerance class: Medium Class

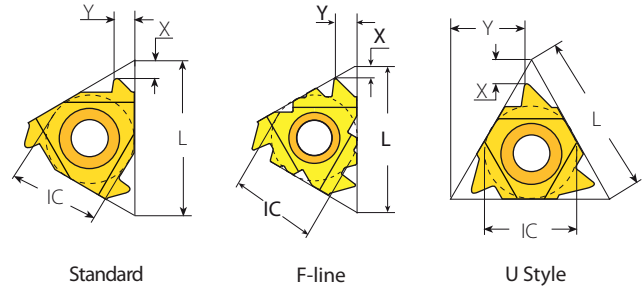

Standard F-line U Style

Standard - Internal



FLINE

Insert Size		Pitch	Ordering Code		Dimensions inch			Anvil		Toolholder
IC	L inch	mm	RH	LH	h min	X	Y	RH	LH	
3/8"	.63	2.0	3IR2.0SAGE...	3IL2.0SAGE...	.059	.06	.09	YI3	YE3	AVR..-3 (LH)
1/2"	.87	3.0	4IR3.0SAGE...	4IL3.0SAGE...	.089	.07	.11	YI4	YE4	AVR..-4 (LH)
		4.0	4IR4.0SAGE...	4IL4.0SAGE...	.122	.08	.13			
1/2" F	.91	3.0	4FIR3.0SAGE...		.089	.07	.11	YI4F		AVRC...-4F
		4.0	4FIR4.0SAGE...		.122	.08	.13			
5/8"	1.06	4.0	5IR4.0SAGE...	5IL4.0SAGE...	.122	.08	.13	YI5 082/039	YE5 082/038	AVR..-5 (LH)

U Style - Internal



Insert Size		Pitch	Ordering Code		Dimensions inch			Anvil		Toolholder
IC	L inch	mm	RH	LH	h min	X	Y	RH	LH	
1/2" U	.87	5.0	4UIR5.0SAGE...	4UIL5.0SAGE...	.148	.07	.41	YI4U-5S	YE4U-5S	AVR..-4U (LH)
		6.0	4UIR6.0SAGE...	4UIL6.0SAGE...	.179	.07	.40	YI4U-6S	YE4U-6S	

Internal

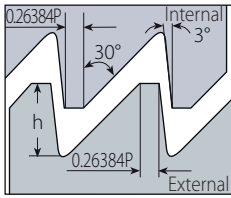

Defined by: DIN 513
Tolerance class: Medium Class

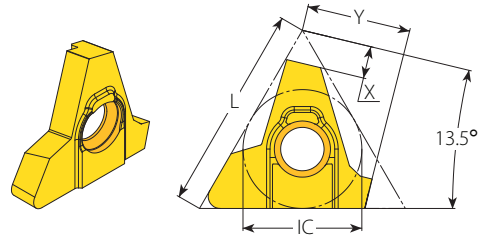

Mega Line

Internal



Insert Size	Pitch	Ordering Code	EDP No.	Dimensions inch			Number of Passes			
				IC	L inch	mm	RH	VKX	h min	X
5/8" MG	10.0	5MGIR10.0SAGE...	42527	.284	.11				103	48
	12.0	5MGIR12.0SAGE...	42528	.341	.13				124	58
	14.0	5MGIR14.0SAGE...	42529	.398	.15	.54			145	67
	16.0	5MGIR16.0SAGE...	42520	.456	.17				165	77
	20.0	5MGIR20.0SAGE...	42521	.571	.20				207	97

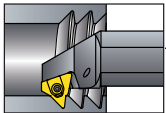

Internal Toolholders for Metric Buttress (Sägewinde) MEGALINE

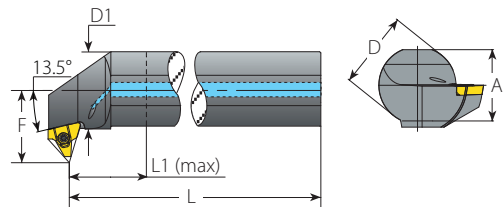
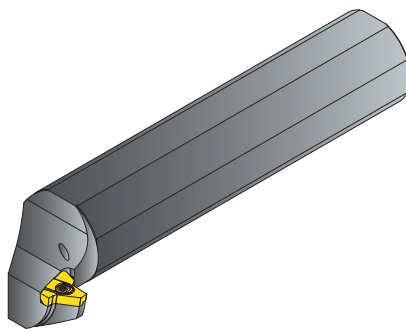

Internal

Spare Parts

Insert	Ordering Code	EDP No.	Dimensions inch							Min. Bore Dia.	Thread Diameter Range (Min.-Max.)		Insert Screw	Torx Key
			RH	A	L	L1 (max)	D	D1	F		inch	Short Chip Material		
5MGIR10.0SAGE...	NVRC150-5MG10SAGE	66389	1.42	9.07	4	1.5	1.49	1.22	1.97		(S65-80)x10	(S75-80)x10	S5MG	K6T
	NVRC150-5MG12SAGE	66390	1.42	9.07	4	1.5	1.49	1.63	2.64		(S85-400)x12	(S90-400)x12		
5MGIR12.0SAGE...	NVRC200-5MG12SAGE	66391	1.81	10.05	5	2.0	1.99	1.83	2.84		(S90-400)x12	(S105-400)x12		
	NVRC250-5MG12SAGE	66392	2.28	11.04	6	2.5	2.49	2.03	3.27		(S105-400)x12	(S250-400)x12		
5MGIR14.0SAGE...	NVRC150-5MG14SAGE	66393	1.42	9.07	4	1.5	1.49	1.63	3.70		(S115-145)x14	(S115-145)x14		
	NVRC200-5MG14SAGE	66395	1.81	10.05	5	2.0	1.99	1.83	3.70		(S115-145)x14	(S115-145)x14		
	NVRC250-5MG14SAGE	66396	2.28	11.04	6	2.5	2.49	2.03	3.70		(S115-145)x14	(S120-145)x14		
5MGIR16.0SAGE...	NVRC150-5MG16SAGE	66397	1.42	9.07	4	1.5	1.49	1.63	4.96		(S150-175)x16	(S150-175)x16		
	NVRC200-5MG16SAGE	66398	1.81	10.05	5	2.0	1.99	1.83	4.96		(S150-175)x16	(S150-175)x16		
	NVRC250-5MG16SAGE	66399	2.28	11.04	6	2.5	2.49	2.03	4.96		(S150-175)x16	(S150-175)x16		
5MGIR20.0SAGE...	NVRC150-5MG20SAGE	66400	1.42	9.07	4	1.5	1.49	1.63	2.95		(S105-230)x20	(S105-230)x20		
	NVRC200-5MG20SAGE	66401	1.81	10.05	5	2.0	1.99	1.83	2.95		(S105-230)x20	(S210-230)x20		
	NVRC250-5MG20SAGE	66402	2.28	11.04	6	2.5	2.49	2.03	3.19		(S210-230)x20	(S210-230)x20		

Recommended thread infeed method for Mega Line: Flank or Modified Flank 1°.

API

External

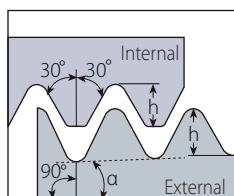

$$\alpha = \arctg (IPF/24)$$

Defined by: API SPEC. 7:1990
Tolerance class: Standard API

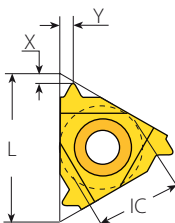

Standard

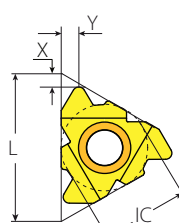

F-Line

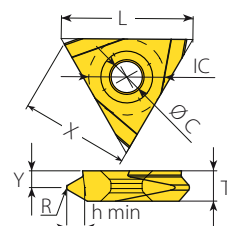

On Edge

Standard



F LINE

Insert Size		Pitch	Thread	Taper	Ordering Code	Size	Dimensions inch			Anvil	
IC	L inch	TPI	IPF	RH			h min	X	Y	RH	Toolholder
1/2"	.87	4	V-0.038R	2	4ER4API382...	NC23-NC50	.122	.08	.11	YEI 4-API-1P or YE4	AL...-4 5BUT/API or AL...-4
		4	V-0.038R	3	4ER4API383...	NC56-NC77	.121	.08	.11		
		4	V-0.050	2	4ER4API502...	6 5/8" REG, 5 1/2" FH, 6 5/8" FH	.148	.08	.11		
		4	V-0.050	3	4ER4API503...	5 1/2", 7 5/8", 8 5/8" REG	.147	.08	.11		
		5	V-0.040	3	4ER5API403...	2 3/8"-4 1/2" REG	.118	.07	.10		
1/2" F	.91	4	V-0.038R	2	4FER4API382...	NC23-NC50	.122	.08	.11	YE4F	AL...-4F
		4	V-0.038R	3	4FER4API383...	NC56-NC77	.121	.08	.11		
		4	V-0.050	2	4FER4API502...	6 5/8" REG, 5 1/2" FH, 6 5/8" FH	.148	.08	.11		
		4	V-0.050	3	4FER4API503...	5 1/2", 7 5/8", 8 5/8" REG	.147	.08	.11		
		5	V-0.040	3	4FER5API403...	2 3/8"-4 1/2" REG	.118	.07	.10		
5/8"	1.06	4	V-0.038R	2	5ER4API382...	NC23-NC50	.122	.08	.11	YE5OIL	AL...-5 OIL
		4	V-0.038R	3	5ER4API383...	NC56-NC77	.121	.08	.11		
		4	V-0.050	2	5ER4API502...	6 5/8" REG, 5 1/2" FH, 6 5/8" FH	.148	.08	.12		
		4	V-0.050	3	5ER4API503...	5 1/2", 7 5/8", 8 5/8" REG	.147	.08	.12		
		5	V-0.040	3	5ER5API403...	2 3/8"-4 1/2" REG	.118	.07	.11		
4	V-0.065	2	5ER4API652...	2 3/8" IF - 5 1/2 IF	.111	.09	.11				

On Edge



Insert Size		Pitch	Thread	Taper	Ordering Code	Size	Dimensions inch				Position	
IC	L inch	TPI	IPF	RH			R	h min	T	Ø C	X	Y
5/8"	1.06	5	V-0.040	3	TNEC54ER5API403...	2 3/8"-4 1/2" REG	.020	.118	.25	.26	.92	.15
		4	V-0.050	2	TNEC55ER4API502...	6 5/8" REG, 5 1/2 FH, 6 5/8 FH	.025	.148	.31			.20
		4	V-0.050	3	TNEC55ER4API503...	5 1/2", 7 5/8", 8 5/8" REG	.025	.148	.31			.20
		4	V-0.038	2	TNEC55ER4API382...	NC23-NC50, 2 3/8 - 6 5/8 IF	.038	.122	.31			.20
		4	V-0.038	3	TNEC55ER4API383...	NC56-NC77	.038	.122	.31			.20

On Edge inserts are compatible with most commonly used toolholders in the market.

API (con't)

Internal

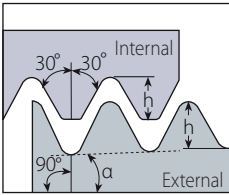

$\alpha = \arctg (IPF/24)$

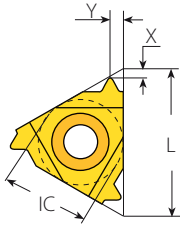

Standard

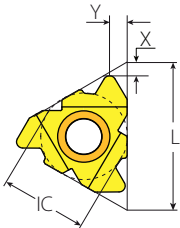

F-Line

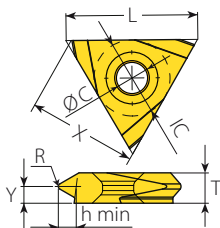

On Edge

Defined by: API SPEC. 7:1990
Tolerance class: Standard API

Standard



Insert Size		Pitch	Thread	Taper	Ordering Code		Size	Dimensions inch			Anvil	Toolholder
IC	L inch	TPI	IPF	RH				h min	X	Y	RH	
1/2"	.87	4	V-0.038R	2	4IR4API382...	NC23-NC50		.122	.08	.11	YEI 4-API-1P or YI4	AVRC...-4 5BUT/API or AVR...-4
		4	V-0.038R	3	4IR4API383...	NC56-NC77		.121	.08	.11		
		4	V-0.050	2	4IR4API502...	6 5/8" REG, 5 1/2"FH, 6 5/8" FH		.148	.08	.12		
		4	V-0.050	3	4IR4API503...	5 1/2", 7 5/8", 8 5/8" REG		.147	.08	.11		
		5	V-0.040	3	4IR5API403...	2 3/8"-4 1/2" REG		.118	.07	.10		
1/2" F	.91	4	V-0.038R	2	4FIR4API382...	NC23-NC50		.122	.08	.11	YI4F	AVRC...-4F
		4	V-0.038R	3	4FIR4API383...	NC56-NC77		.121	.08	.11		
		4	V-0.050	2	4FIR4API502...	6 5/8" REG, 5 1/2"FH, 6 5/8"FH		.148	.08	.12		
		4	V-0.050	3	4FIR4API503...	5 1/2", 7 5/8", 8 5/8" REG		.147	.08	.11		
		5	V-0.040	3	4FIR5API403...	2 3/8"-4 1/2" REG		.118	.07	.10		
5/8"	1.06	4	V-0.038R	2	5IR4API382...	NC23-NC50		.122	.08	.11	YI5OIL	AVR...-5 OIL
		4	V-0.038R	3	5IR4API383...	NC56-NC77		.121	.08	.11		
		4	V-0.050	2	5IR4API502...	6 5/8" REG, 5 1/2"FH, 6 5/8" FH		.148	.08	.12		
		4	V-0.050	3	5IR4API503...	5 1/2", 7 5/8", 8 5/8" REG		.147	.08	.12		
		5	V-0.040	3	5IR5API403...	2 3/8"-4 1/2" REG		.118	.07	.11		
		4	V-0.065	2	5IR4API652...	2 3/8"IF- 5 1/2"IF		.111	.09	.11		

On Edge



Insert Size		Pitch	Thread	Taper	Ordering Code		Size	Dimensions inch				Position	
IC	L inch	TPI	IPF	RH				R	h min	T	ØC	X	Y
5/8"	1.06	5	V-0.040	3	TNEC54IR5API403...	2 3/8"-4 1/2" REG		.020	.118	.25	.26	.92	.15
		4	V-0.050	2	TNEC55IR4API502...	6 5/8" REG, 5 1/2 FH, 6 5/8 FH		.025	.148	.31			.20
		4	V-0.050	3	TNEC55IR4API503...	5 1/2", 7 5/8", 8 5/8" REG		.025	.148	.31			.20
		4	V-0.038	2	TNEC55IR4API382...	NC23-NC50, 2 3/8 - 6 5/8 IF		.038	.122	.31			.20
		4	V-0.038	3	TNEC55IR4API383...	NC56-NC77		.038	.122	.31			.20

On Edge inserts are compatible with most commonly used toolholders in the market.

API Buttress Casing

External

Defined by: STD.5B.1979
Tolerance class: Standard API

Standard



IC	Insert Size		Pitch	Taper	Ordering Code	Size	Dimensions inch			Anvil	Toolholder
	L inch	TPI	IPF	RH	h min	X	Y	RH			
1/2"	.87	5	.75	4ER5BUT75...	4 1/2"-13 3/8"	.061	.12	.07	YEI 4-BUT or YE4	AL...-4 5BUT/API or AL...-4	
		5	1	4ER5BUT1...	16"-20"	.061	.12	.07			
1/2"F	.91	5	.75	4FER5BUT75...	4 1/2"-13 3/8"	.061	.12	.07	YE4F	AL...-4F	
		5	1	4FER5BUT1...	16"-20"	.061	.12	.07			



FLINE

M+ Style



IC	Insert Size		Pitch	Taper	Teeth	Ordering Code	Size	Dimensions inch			Anvil	Toolholder
	L inch	TPI	IPF	RH	h min	X	Y	RH				
5/8"	1.06	5	.75	2	5ER5BUT752M+...	4 1/2"-13 3/8"	.061	.19	.27	YE5M	AL...-5M	

T+ Style



IC	Insert Size		Pitch	Taper	Teeth	Ordering Code	Size	Dimensions inch			Anvil	Toolholder
	L inch	TPI	IPF	RH	h min	X	Y	RH				
1/2"T	.87	5	.75	3	4ER5BUT753T+...	4 1/2"-13 3/8"	.061	.10	.63	Y4T	AL...-4T	
			1	4ER5BUT13T+...	16"-20"							

14D



IC	Insert Size		Pitch	Taper	Teeth	Ordering Code	Size	Dimensions inch		Anvil	Toolholder
	TPI	IPF	RH	h min	Y	RH					
14D	5	.75	2	14DER5BUT752T+...	4 1/2"-9 5/8"	.061	.39	Y14DER-5 BUT		AL...-14D	
				14DER5BUT12T+...	16"-20"			Y14DER-5BUT-0.4N			
				Y14DER-5BUT-0.4N				AL...-14D			

API Buttress Casing (con't)

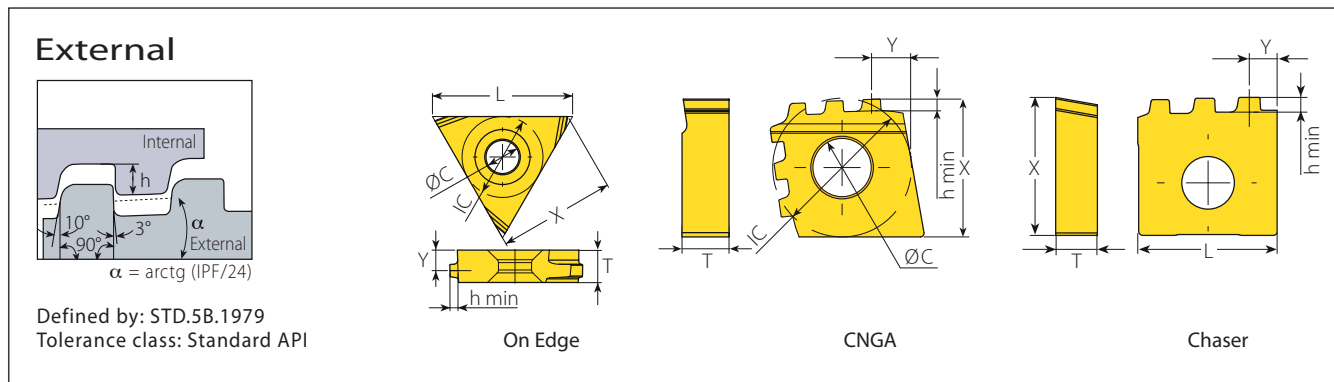

On Edge



Insert Size		Pitch	Taper	Ordering Code	Size	Dimensions inch			Position	
IC	L inch	TPI	IPF	RH		h min	T	Ø C	X	Y
5/8"	1.06	5	.75	TNEC54ER5BUT75...	4 1/2"-13 3/8"	.061	.25	.26	.92	.16
		5	1	TNEC54ER5BUT1...	16"-20"					

On Edge inserts are compatible with most commonly used toolholders in the market.

CNGA

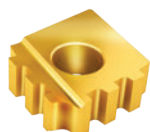

Insert Size		Pitch	Taper	Teeth	Ordering Code	Size	Dimensions inch			Position	
IC	TPI	IPF		RH		h min	T	Ø C	X	Y	
3/4"	5	.75	3	CNGA64ER5BUT75T3...	4 1/2"-13 3/8"	.061	.25	.31	.74	.22	
	5	1	3	CNGA64ER5BUT1T3...	16"-20"						

CNGA inserts are compatible with most commonly used toolholders in the market.

Chaser

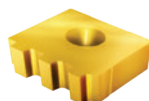

Insert Size		Pitch	Taper	Teeth	Ordering Code	Size	Dimensions inch			Position	
L	TPI	IPF		RH		h min	T	X	Y		
.63	5	.75	3	1616ER5BUT753S+...	4 1/2"-13 3/8"	.061	.19	.62	.13		
	5	1	3	1616ER5BUT13S+...	16"-20"						

Chaser inserts are compatible with most commonly used toolholders in the market.

API Buttress Casing (con't)

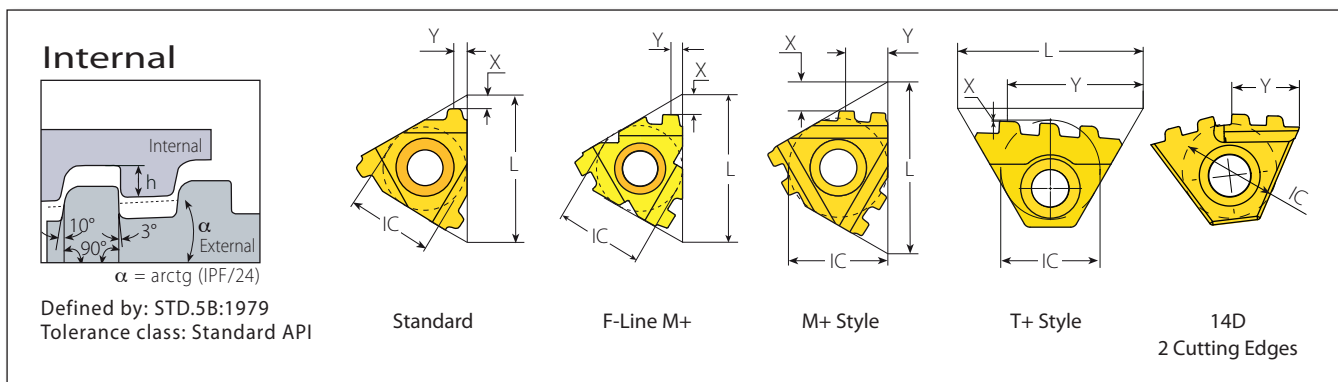

Standard

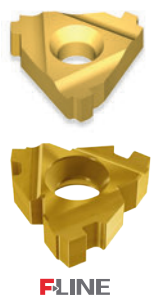

Insert Size		Pitch	Taper	Ordering Code	Size	Dimensions inch			Anvil	
IC	L inch	TPI	IPF	RH		h min	X	Y	RH	Toolholder
1/2"	.87	5	.75	4IR5BUT75...	4 1/2"-13 3/8"	.061	.11	.07	YEI 4-BUT or Y14	AVRC...-4 5BUT/API or AVR...-4
		5	1	4IR5BUT1...	16"-20"	.061	.11	.07		
1/2"F	.91	5	.75	4FIR5BUT75...	4 1/2"-13 3/8"	.061	.11	.07	Y14F	AVRC...-4F
		5	1	4FIR5BUT1...	16"-20"	.061	.11	.07		

FLINE

M+ Style



Insert Size		Pitch	Taper	Teeth	Ordering Code	Size	Dimensions inch			Anvil	
IC	L inch	TPI	IPF	RH		h min	X	Y	RH	Toolholder	
5/8"	1.06	5	.75	2	5IR5BUT752M+...	4 1/2"-13 3/8"	.061	.19	.26	Y15M	AVR...-5M

T+ Style



Insert Size		Pitch	Taper	Teeth	Ordering Code	Size	Dimensions inch			Anvil	
IC	L inch	TPI	IPF	RH		h min	X	Y	RH	Toolholder	
1/2"T	.87	5	.75	3	4IR5BUT753T+...	4 1/2"-13 3/8"	.061	.10	.63	Y4T	AVR...-4T
			1		4IR5BUT13T+...	16"-20"					

14D

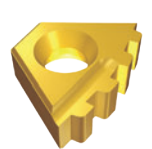

Insert Size		Pitch	Taper	Teeth	Ordering Code	Size	Dimensions inch		Anvil	
IC	TPI	IPF	RH		h min	Y	RH	Toolholder		
14D	5	.75	2	14DIR5BUT752T+...	4 1/2"-9 5/8"	.061	.39	Y14DIR-5 BUT	AVRC...-14D	
		1		14DIR5BUT12T+...	10 3/4"-13 3/8"			Y14DIR-5BUT-0.4N		
	5	1	2	14DIR5BUT12T+...	16"-20"	.061	.39	Y14DIR-5BUT-0.4N	AVRC...-14D	

API Buttress Casing (con't)

Internal

Defined by: STD.5B:1979
Tolerance class: Standard API

On Edge



Insert Size		Pitch	Taper	Ordering Code	Size	Dimensions inch			Position	
IC	L inch	TPI	IPF	RH		h min	T	Ø C	X	Y
5/8"	1.06	5	.75	TNEC54IR5BUT75...	4 1/2"-13 3/8"	.061	.25	.26	.92	.17
		5	1	TNEC54IR5BUT1...	16"-20"					

On Edge inserts are compatible with most commonly used toolholders in the market.

CNGA

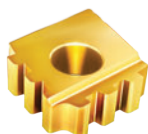

Insert Size		Pitch	Taper	Teeth	Ordering Code	Size	Dimensions inch			Position	
IC	TPI	IPF		RH		h min	T	Ø C	X	Y	
3/4"	5	.75	3	CNGA64IR5BUT75T3...	4 1/2"-13 3/8"	.061	.25	.31	.74	.22	
	5	.75	2	CNGA64IR5BUT75T2...	4 1/2"-13 3/8"					.41	
	5	1	3	CNGA64IR5BUT1T3...	16"-20"					.22	

CNGA inserts are compatible with most commonly used toolholders in the market.

Chaser

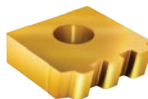

Insert Size		Pitch	Taper	Teeth	Ordering Code	Size	Dimensions inch			Position	
L	TPI	IPF		RH		h min	T	X	Y		
.63	5	.75	3	1616IR5BUT75S3+...	4 1/2"-13 3/8"	.061	.19	.62	.13		
	5	1	3	1616IR5BUT13S+...	16"-20"						

Chaser inserts are compatible with most commonly used toolholders in the market.

API Round Casing & Tubing

External

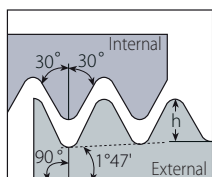

Defined by: API STD. 5B:1979
Tolerance class: Standard API RD

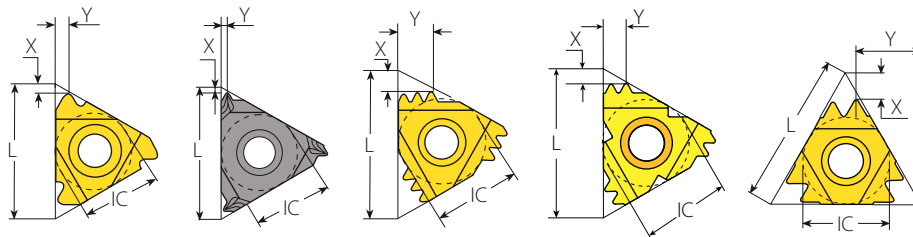

Standard SCB Sintered Chipbreaker M+ Style F-Line M+ Z+ Style

Standard

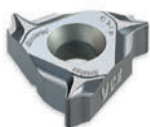

SCB

Insert Size		Pitch	Ordering Code	Dimensions inch			Anvil	
IC	L inch	TPI	RH	h min	X	Y	RH	Toolholder
3/8"	.63	10	3ER10APIRD...	.056	.05	.06	YEI3-APIRD or YE3	AL...-3 APIRD or AL...-3
		8	3ER8APIRD...	.071	.05	.06		
3/8" SCB	.63	10	3JER10APIRD...	.056	.05	.06		
		8	3JER8APIRD...	.071	.05	.06		

M+ Style



F.LINE

Insert Size		Pitch	Teeth	Ordering Code	Dimensions inch			Anvil	
IC	L inch	TPI		RH	h min	X	Y	RH	Toolholder
1/2"	.87	10	2	4ER10APIRD2M+...	.056	.09	.15	YE4M	AL...-4
1/2"F	.91	10	2	4FER10APIRD2M+...	.056	.09	.15	YE4M2F	AL...-4MF
5/8"	1.06	10	3	5ER10APIRD3M+...	.056	.15	.25	YE5M	AL...-5M
		8	2	5ER8APIRD2M+...	.071	.11	.18		

Z+ Style



Insert Size		Pitch	Teeth	Ordering Code	Dimensions inch			Anvil	
IC	L inch	TPI		RH	h min	X	Y	RH	Toolholder
1/2"	.87	10	2	4ER10APIRD2Z+...	.056	.12	.39	YE4Z	AL...-4Z
		8	2	4ER8APIRD2Z+...	.071	.15	.38		

API Round Casing & Tubing (con't)

External

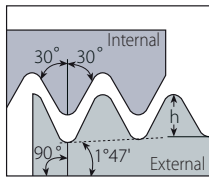

Defined by: API STD. 5B:1979
Tolerance class: Standard API RD

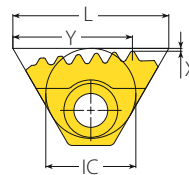

T+ Style

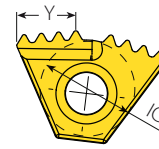

14D -
2 Cutting Edges

T+ Style

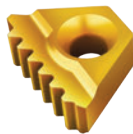

Insert Size		Pitch	Teeth	Ordering Code	Dimensions inch			Anvil	
IC	L inch	TPI		RH	h min	X	Y	RH	Toolholder
1/2" T	.87	10	6	4ER10APIRD6T+...	.056	.01	.64		
		8	3	4ER8APIRD3T+...	.071	.01	.56	Y4T	AL...-4T
		8	5	4ER8APIRD5T+...	.071	.01	.66		

14D

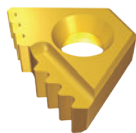

Insert Size		Pitch	Teeth	Ordering Code	Size	Dimensions inch		Anvil	
IC	TPI			RH		h min	Y	RH	Toolholder
14D		10	4	14DER10APIRD4T+...	2 3/8" and up	.056	.34	Y14DER-10 APIRD	
		10	3	14DER10APIRD3T+...	2 3/8" and up		.35	Y14DER-10 APIRD-3+	AL...-14D
		8	3	14DER8APIRD3T+...	2 3/8" and up	.071	.32	Y14DER-8 APIRD	

API Round Casing & Tubing (con't)

External

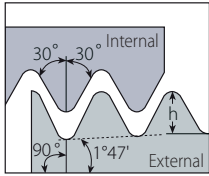

Defined by: API STD. 5B:1979
Tolerance class: Standard API RD

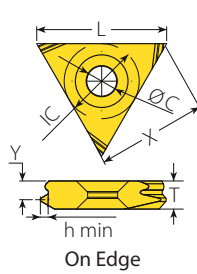

On Edge

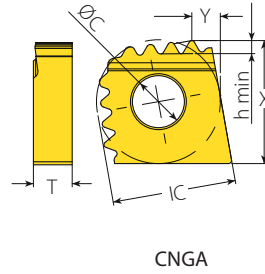

CNGA

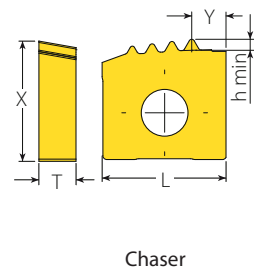

Chaser

On Edge



Insert Size		Pitch	Ordering Code	Dimensions inch			Position	
IC	L inch	TPI	RH	h min	T	Ø C	X	Y
1/2"	.87	10	TNEC43ER10APIRD...	.056	.19	.20	.73	.13
		8	TNEC43ER8APIRD...	.071				

On Edge inserts are compatible with most commonly used toolholders in the market.

CNGA

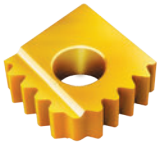

Insert Size		Pitch	Teeth	Ordering Code	Dimensions inch			Position	
IC	TPI		RH	h min	T	Ø C	X	Y	
3/4"	10	5	CNGA64ER10APIRDT5...	.056	.25	.31	.74	.18	
	8	4	CNGA64ER8APIRDT4...	.071					

CNGA inserts are compatible with most commonly used toolholders in the market.

Chaser

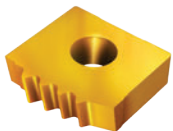

Insert Size		Pitch	Teeth	Ordering Code	Dimensions inch			Position	
L	TPI		RH	h min	T	X	Y		
.63	10	4	1616ER10APIRD4S+...	.056	.19	.61	.17		
	8	3	1616ER8APIRD3S+...	.071				.63	

Chaser inserts are compatible with most commonly used toolholders in the market.

API Round Casing & Tubing (con't)

Internal

Defined by: API STD. 5B:1979
Tolerance class: Standard
API RD

Standard

SCB
Sintered
Chipbreaker

M+ Style

F-Line M+

Z+ Style

Standard



SCB

Insert Size		Pitch	Ordering Code		Dimensions inch			Anvil	
IC	L inch	TPI	RH		h min	X	Y	RH	Toolholder
3/8"	.63	10	3IR10APIRD...		.056	.05	.06	YEI3-APIRD or YI3	AVRC... 3APIRD or AVRC...-3
		8	3IR8APIRD...		.071	.05	.06		
3/8" SCB	.63	10	3JR10APIRD...		.056	.05	.06		
		8	3JR8APIRD...		.071	.05	.06		

M+ Style



F-LINE

Insert Size		Pitch	Teeth	Ordering Code		Dimensions inch			Anvil	
IC	L inch	TPI		RH		h min	X	Y	RH	Toolholder
1/2"	.87	10	2	4IR10APIRD2M+...		.056	.09	.15	YI4M	AVR...-4
		8	2	4IR8APIRD2M+...		.071	.11	.18		
1/2" F	.91	10	2	4FIR10APIRD2M+...		.056	.09	.15	YI4M2F	AVRC...-4MF
		8	2	4FIR8APIRD2M+...		.071	.11	.18		
5/8"	1.06	10	3	5IR10APIRD3M+...		.056	.15	.25	YI5M	AVR...-5M
		8	2	5IR8APIRD2M+...		.071	.11	.18		

Z+ Style



Insert Size		Pitch	Teeth	Ordering Code		Dimensions inch			Anvil	
IC	L inch	TPI		RH		h min	X	Y	RH	Toolholder
1/2"	.87	10	2	4IR10APIRD2Z+...		.056	.12	.39	YI4Z	AVR...-4Z
		8	2	4IR8APIRD2Z+...		.071	.15	.38		

API Round Casing & Tubing (con't)

Internal

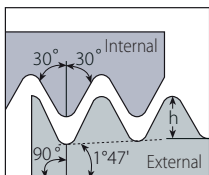

Defined by: STD. 5B:1979
Tolerance class: Standard API RD

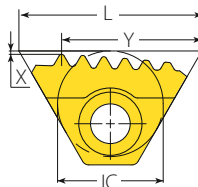

Z+ Style

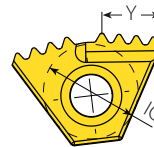

14D -
2 Cutting Edges

T+ Style



Insert Size		Pitch	Teeth	Ordering Code	Dimensions inch			Anvil	Toolholder
IC	L inch	TPI	RH	h min	X	Y	RH		
1/2" T	.87	10	6	4IR10APIRD6T+...	.056	.01	.66	Y4T	AVR...-4T
		8	3	4IR8APIRD3T+...	.071	.01	.56		
		8	5	4IR8APIRD5T+...	.071	.01	.66		

14D

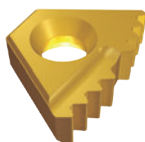

Insert Size		Pitch	Teeth	Ordering Code	Size	Dimensions inch		Anvil	Toolholder
IC	TPI				h min	Y			
14D	10	4	14DIR10APIRD4T+...	2 3/8" and up	.056	.34	Y14DIR-10 APIRD	AVRC...-14D	
	10	3	14DIR10APIRD3T+...	2 3/8" and up		.35	Y14DIR-10 APIRD-3+		
	8	3	14DIR8APIRD3T+...	2 3/8" and up		.071	.32		Y14DIR-8 APIRD

API Round Casing & Tubing (con't)

Internal

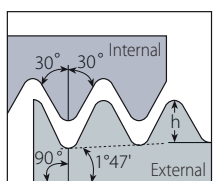

Defined by: STD. 5B:1979
Tolerance class: Standard API RD

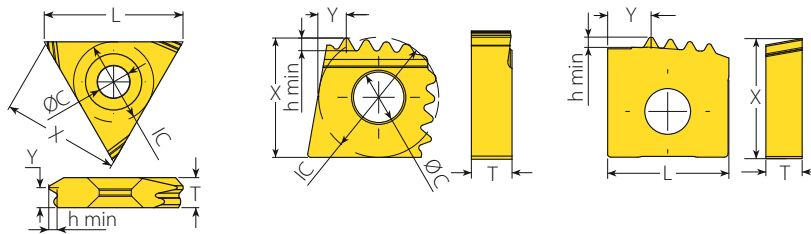

On Edge
CNGA
Chaser

On Edge



Insert Size		Pitch	Ordering Code		Dimensions inch			Position	
IC	L inch	TPI	RH		h min	T	Ø C	X	Y
1/2"	.87	10	TNEC43IR10APIRD...		.056	.19	.20	.73	.13
		8	TNEC43IR8APIRD...		.071				

On Edge inserts are compatible with most commonly used toolholders in the market.

CNGA

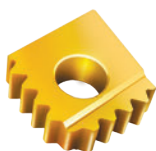

Insert Size		Pitch	Teeth	Ordering Code		Dimensions inch			Position	
IC	TPI			RH		h min	T	Ø C	X	Y
3/4"	10	5		CNGA64IR10APIRDT5...		.056	.25	.31	.74	.18
	8	4		CNGA64IR8APIRDT4...		.071				

CNGA inserts are compatible with most commonly used toolholders in the market.

Chaser

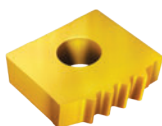

Insert Size		Pitch	Teeth	Ordering Code		Dimensions inch		Position	
L	TPI			RH		h min	T	X	Y
.63	10	4		1616IR10APIRD4S+...		.056	.19	.61	.22
	8	3		1616IR8APIRD3S+...		.071			

Chaser inserts are compatible with most commonly used toolholders in the market.

VAM

External

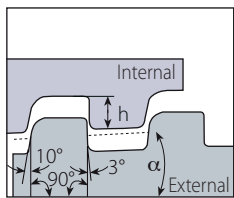

$\alpha = \arctg (IPF/24)$

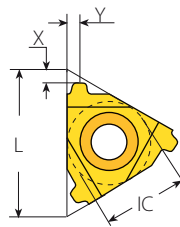

Standard

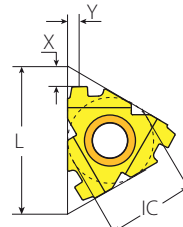

F-Line

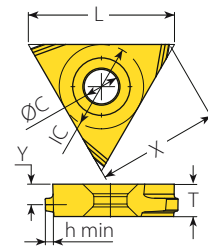

On Edge

Defined by: VAM
Tolerance class: Standard VAM

Standard



FLINE

Insert Size		Pitch	Taper	Ordering Code	Size	Dimensions inch			Anvil	
IC	L inch	TPI	IPF	RH		h min	X	Y	RH	Toolholder
3/8"	.63	8		3ER8VAM...	2 3/8", 2 7/8"	.038	.07	.07	YE3	AL...-3
1/2"	.87	6	.75	4ER6VAM...	3 1/2"	.038	.09	.09	YE4	AL...-4
		5		4ER5VAM...	5"-9 5/8"	.061	.09	.11		
1/2"F	.91	6		4FER6VAM...	3 1/2"	.038	.09	.09	YE4F	AL...-4F
		5		4FER5VAM...	5"-9 5/8"	.061	.09	.11		

On Edge



Insert Size		Pitch	Taper	Ordering Code	Size	Dimensions inch			Position	
IC	L inch	TPI	IPF	RH		h min	T	ØC	X	Y
1/2"	.87	8	.75	TNEC43ER8VAM...	2 3/8", 2 7/8"	.038	.19	.20	.73	.13
		6		TNEC43ER6VAM...	3 1/2"	.038	.19			.11
5/8"	1.06	5		TNEC54ER5VAM...	5"-9 5/8"	.061	.25	.26	.92	.16

On Edge inserts are compatible with most commonly used toolholders in the market.

VAM (con't)

Internal

Defined by: VAM
Tolerance class: Standard VAM

Standard

F-Line

On Edge

CNGA

Standard

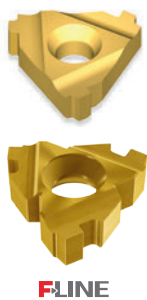

F-Line

Insert Size	Pitch		Taper	Ordering Code	Size	Dimensions inch			Anvil	Toolholder
	IC	L inch				TPI	IPF	RH		
3/8"	.63	8		3IR8VAM...	2 3/8", 2 7/8"	.040	.07	.07	Y13	AVR...-3
				4IR6VAM...						
1/2"	.87	6	.75	4IR5VAM...	5"-9 5/8"	.061	.09	.10	Y14F	AVRC...-4F
		5		4FIR6VAM...						
1/2"F	.91	6		4FIR5VAM...	5"-9 5/8"	.061	.09	.10		
		5								

On Edge



Insert Size	Pitch		Taper	Ordering Code	Size	Dimensions inch			Position	
	IC	L inch				TPI	IPF	RH	h min	T
1/2"	.87	8	.75	TNEC43IR8VAM...	2 3/8", 2 7/8"	.040	.19	.20	.73	.13
		6		TNEC43IR6VAM...						
5/8"	1.06	5		TNEC54IR5VAM...	5"- 9 5/8"	.061	.25	.26	.92	.17

On Edge inserts are compatible with most commonly used toolholders in the market.

CNGA

Multiplus

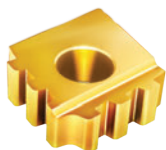

Insert Size	Pitch	Taper	Teeth	Ordering Code	Size	Dimensions inch			Position	
						IC	TPI	IPF	RH	h min
3/4"	5	.75	2	CNGA64IR5VAM75T2...	5"- 9 5/8"	.061	.25	.31	.74	.37

CNGA inserts are compatible with most commonly used toolholders in the market.

New VAM

External

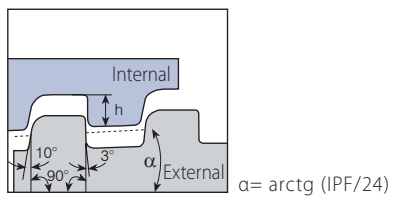

Defined by: VAM
Tolerance class: Standard VAM

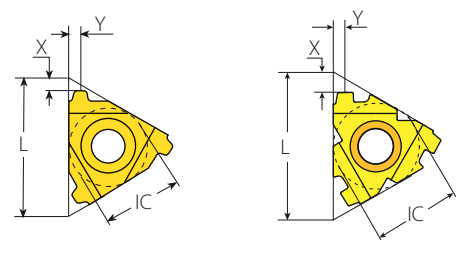

Standard F-Line

Standard



Insert Size		Pitch	Taper	Ordering Code	Size	Dimensions inch			Anvil	Toolholder
IC	L inch	TPI	IPF	RH		h min	X	Y	RH	
3/8"	.63	8	.75	3ER8NVAM...	2 3/8", 2 7/8"	.038	.07	.07	YE3	AL...-3
		6		4ER6NVAM...	3 1/2"	.038	.09	.09	YE4	AL...-4
5	4ER5NVAM...	5"-9 5/8"		.061	.09	.09				
6	4FER6NVAM...	3 1/2"		.038	.09	.08	YE4F	AL...-4F		
1/2"	.87	6		4FER5NVAM...	5"-9 5/8"	.061	.10	.09		
		5								
1/2"F	.91	6								
		5								

New VAM (con't)

Internal

Defined by: VAM
Tolerance class: Standard VAM

Standard

F-Line

On Edge

CNGA

Standard

Insert Size	Pitch	Taper	Ordering Code	Size	Dimensions inch			Anvil	
					IC	L inch	TPI	IPF	RH
3/8"	.63	8	3IR8NVAM...	2 3/8", 2 7/8"	.048	.07	.07	Y13	AVR...-3
1/2"	.87	6	4IR6NVAM...	3 1/2"	.048	.10	.10	Y14	AVR...-4
		5	4IR5NVAM...	5"-9 5/8"	.070	.09	.10		
1/2"F	.91	6	4FIR6NVAM...	3 1/2"	.048	.08	.07	Y14F	AVRC...-4F
		5	4FIR5NVAM...	5"-9 5/8"	.070	.08	.08		

FLINE

On Edge

Insert Size	Pitch	Taper	Ordering Code	Size	Dimensions inch				
					IC	L inch	TPI	IPF	RH
1/2"	.87	8	TNEC43IR8NVAM...	2 3/8" - 2 7/8"	.048	.19	.20	.73	.13
		6	TNEC43IR6NVAM...	3 1/2" - 4 1/2"	.048	.19	.20	.92	.12
5/8"	1.06	5	TNEC54IR5NVAM...	5"-16"	.070	.25	.26		.17

On Edge inserts are compatible with most commonly used toolholders in the market.

CNGA

Insert Size	Pitch	Taper	Teeth	Ordering Code	Size	Dimensions inch			Position	
						IC	TPI	IPF	RH	h min
3/4"	6	.75	2	CNGA64IR6NVAM75T2...	3 1/2" - 4 1/2"	.048	.25	.31	.74	.37
				CNGA64IR5NVAM75T2...	5"-16"	.070	.25			

CNGA inserts are compatible with most commonly used toolholders in the market.

Multiplus

EL-Extreme Line

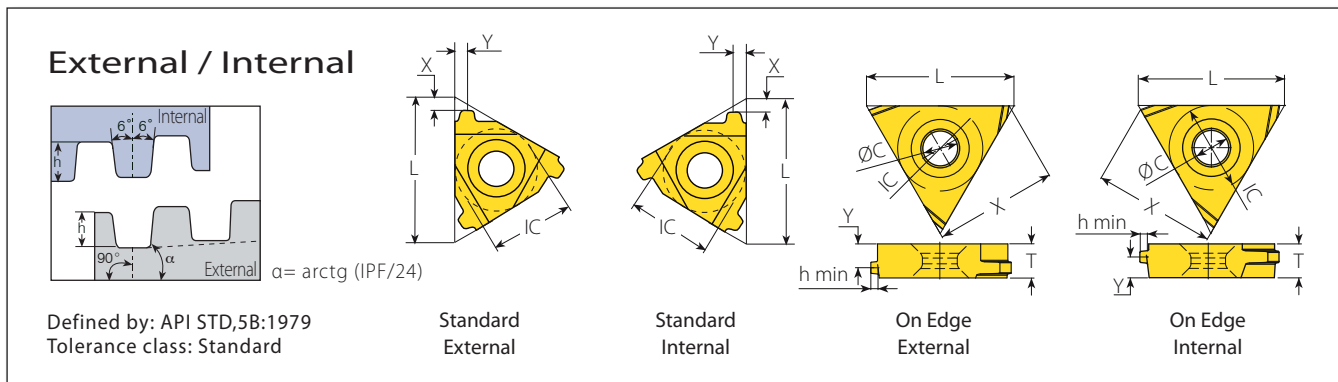

Standard - External



Insert Size		Pitch	Taper	Ordering Code	Size	Dimensions inch			Anvil	
IC	L inch	TPI	IPF	RH		h min	X	Y	RH	Toolholder
1/2"	.87	6	1.5	4ER6EL15...	5"-7 5/8"	.048	.07	.07	YE4	AL..-4
		5	1.25	4ER5EL125...	8 5/8"-10 3/4"	.067	.09	.09		

On Edge - External



Insert Size		Pitch	Taper	Ordering Code	Size	Dimensions inch			Position	
IC	L inch	TPI	IPF	RH		h min	T	Ø C	X	Y
5/8"	1.06	6	1.5	TNEC54ER6EL15...	5"-7 5/8"	.048	.25	.26	.92	.19
		5	1.25	TNEC54ER5EL125...	8 5/8"-10 3/4"	.067	.25			

On Edge inserts are compatible with most commonly used toolholders in the market.

Standard - Internal



Insert Size		Pitch	Taper	Ordering Code	Size	Dimensions inch			Anvil	
IC	L inch	TPI	IPF	RH		h min	X	Y	RH	Toolholder
1/2"	.87	6	1.5	4IR6EL15...	5"-7 5/8"	.055	.07	.07	Y14	AVR..-4
		5	1.25	4IR5EL125...	8 5/8"-10 3/4"	.075	.09	.09		

On Edge - Internal



Insert Size		Pitch	Taper	Ordering Code	Size	Dimensions inch			Position	
IC	L inch	TPI	IPF	RH		h min	T	Ø C	X	Y
5/8"	1.06	6	1.5	TNEC54IR6EL15...	5"-7 5/8"	.055	.25	.26	.92	.19
		5	1.25	TNEC54IR5EL125...	8 5/8"-10 3/4"	.075	.25			

On Edge inserts are compatible with most commonly used toolholders in the market.

Hughes H-90

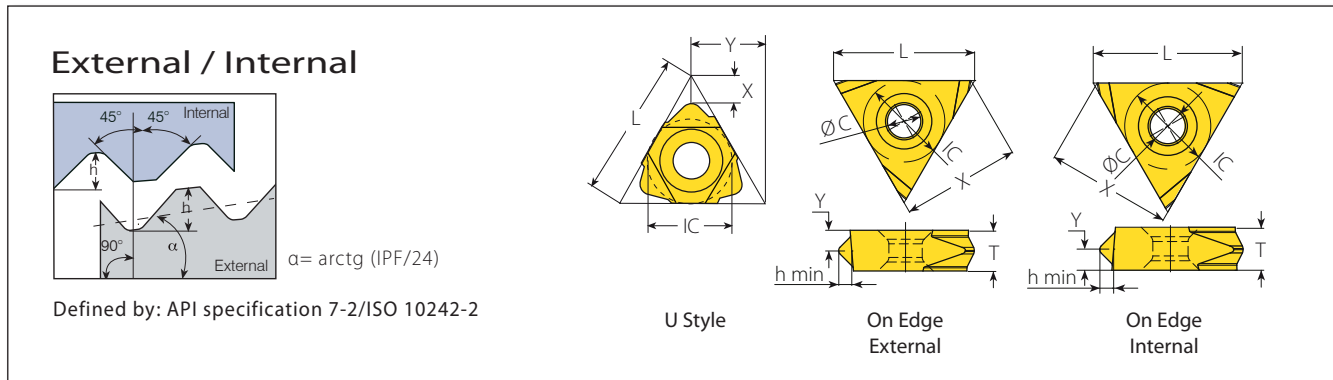

U Style - External



Insert Size	Pitch	Taper	Ordering Code	Size	Dimensions inch			Anvil		
					IC	L inch	TPI	IPF	RH	Toolholder
1/2" U	.87	3.5	2	4UER3.5H902...	3 1/2"-6 5/8"	.098	.17	.43	YE4U-H90	AL...-4U
				4UER3.5H903...	7"-8 5/8"	.098	.17	.43	YE5U-H90	AL...-5UH90
5/8" U	1.06	3	1.25*	5UER3H90SL...	2 3/8"-3 1/2"	.088	.22	.54		

On Edge - External



Insert Size	Pitch	Taper	Ordering Code	Size	Dimensions inch			Position				
					IC	L inch	TPI	IPF	RH	h min	T	Ø C
5/8"	1.06	3.5	2	TNEC55ER3.5H902...	3 1/2"-6 5/8"	.098	.31				.17	
				3.5	3	TNEC55ER3.5H903...	7"-8 5/8"	.098	.31	.26	.92	.17
						3	1.25*	TNEC56ER3H90SL...	2 3/8"-3 1/2"	.088	.38	

On Edge inserts are compatible with most commonly used toolholders in the market.

U Style - Internal



Insert Size	Pitch	Taper	Ordering Code	Size	Dimensions inch			Anvil		
					IC	L inch	TPI	IPF	RH	Toolholder
1/2" U	.87	3.5	2	4UIR3.5H902...	3 1/2"-6 5/8"	.098	.17	.43	YI4U-H90	AVR...-4U
				4UIR3.5H903...	7"-8 5/8"	.098	.17	.43	YI5U-H90	AVR...-5UH90
5/8" U	1.06	3	1.25*	5UIR3H90SL...	2 3/8"-3 1/2"	.088	.22	.54		

On Edge - Internal



Insert Size	Pitch	Taper	Ordering Code	Size	Dimensions inch			Position				
					IC	L inch	TPI	IPF	RH	h min	T	Ø C
5/8"	1.06	3.5	2	TNEC55IR3.5H902...	3 1/2"-6 5/8"	.098	.31				.17	
				3.5	3	TNEC55IR3.5H903...	7"-8 5/8"	.098	.31	.26	.92	.17
						3	1.25*	TNEC56IR3H90SL...	2 3/8"-3 1/2"	.088	.38	

On Edge inserts are compatible with most commonly used toolholders in the market.

* H-90 Slimline.

Pg

External / Internal

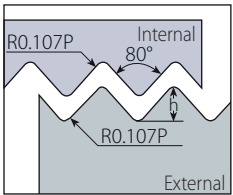

Defined by: DIN 40430
Tolerance class: Standard

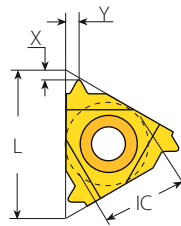

Standard External

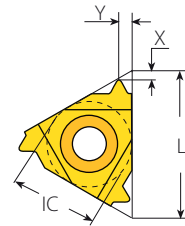

Standard Internal

Standard - External



Insert Size		Pitch	Thread	Ordering Code		Dimensions inch			Anvil		Toolholder
IC	L inch	TPI		RH	LH	h min	X	Y	RH	LH	
1/4"	.43	20	Pg7	2ER20PG...	2EL20PG...	.024	.03	.04	-	-	NL...-2 (LH)
		18	Pg9/11/13.5/16	2ER18PG...	2EL18PG...	.026	.03	.04	-	-	
		16	Pg21/29/36/42/48	2ER16PG...	2EL16PG...	.030	.04	.04	-	-	
3/8"	.63	20	Pg7	3ER20PG...	3EL20PG...	.024	.03	.04	YE3	YI3	AL...-3 (LH)
		18	Pg9/11/13.5/16	3ER18PG...	3EL18PG...	.026	.03	.04	YE3	YI3	
		16	Pg21/29/36/42/48	3ER16PG...	3EL16PG...	.030	.04	.04	YE3	YI3	

Standard - Internal



Insert Size		Pitch	Thread	Ordering Code		Dimensions inch			Anvil		Toolholder
IC	L inch	TPI		RH	LH	h min	X	Y	RH	LH	
1/4"	.43	20	Pg7	2IR20PG...	2IL20PG...	.025	.03	.04	-	-	NVR...-2 (LH)
		18	Pg9/11/13.5/16	2IR18PG...	2IL18PG...	.026	.03	.04	-	-	
		16	Pg21/29/36/42/48	2IR16PG...	2IL16PG...	.030	.04	.04	-	-	
3/8"	.63	20	Pg7	3IR20PG...	3IL20PG...	.025	.03	.04	YI3	YE3	AVR...-3 (LH)
		18	Pg11/13.5/16	3IR18PG...	3IL18PG...	.026	.03	.04	YI3	YE3	
		16	Pg21/29/36/42/48	3IR16PG...	3IL16PG...	.030	.03	.04	YI3	YE3	

Internal

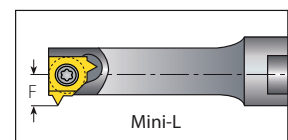
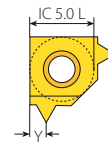
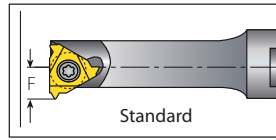
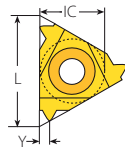
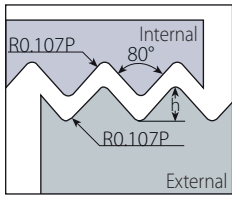

Defined by: DIN 40430
Tolerance class: Standard

Mini-3 Standard



Insert Size		Pitch	Thread	Ordering Code		Dimensions inch			Min. Bore Dia.	Toolholder
IC mm	L inch	TPI		RH	LH	h min	Y	F	inch	
5.0	.31	20	Pg7	5.0KIR20PG...	5.0KIL20PG...	.024	.03	.19	.31	(C)NVR...-5.0K (LH)
		20	Pg7	6.0KIR20PG...	6.0KIL20PG...	.024	.03	.21		
6.0	.39	18	Pg9/11/13.5/16	6.0KIR18PG...	6.0KIL18PG...	.026	.04	.21	.39	.NVR...-6.0K (LH)

Mini-L



Insert Size		Pitch	Thread	Ordering Code		Dimensions inch			Min. Bore Dia.	Toolholder
IC mm	TPI			RH	LH	h min	Y	F	inch	
5.0L	20	Pg7		5LKIR20PG...	5LKIL20PG...	.024	.03	.18	.31	.NVR...-5LK (LH)
	18	Pg9/11/13.5/16		5LKIR18PG...	5LKIL18PG...	.026	.04	.18		

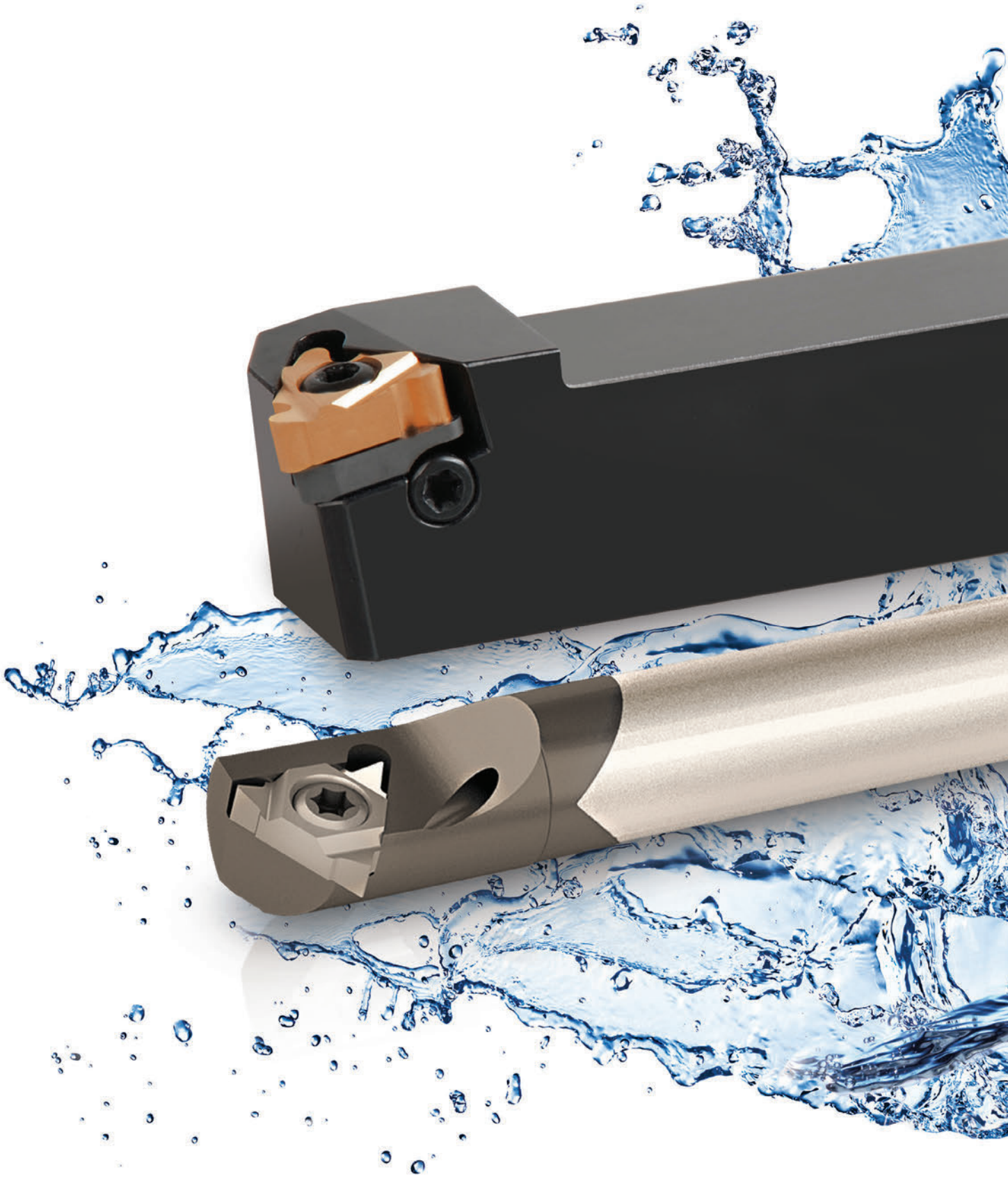

Thread Turning Toolholders

Vardex Ordering Code System

External Toolholders

A 1	L 2	125 3	-	4 4	U 5	C 6	7	8	9
1 - Anvil A - Anvil Required N - No Anvil Required O - Miniature Holder	2 - Holder Style L - External V - Miniature Square Shank VR - Miniature Round Shank		3 - Shank Square [Inch] 031, 3/8, 050, 0625, 075, 100, 125, 150, 200			4 - Insert Size 2 - IC1/4" 3 - IC3/8" 4 - IC1/2" 5 - IC5/8"			
5 - Insert Style U - U style V - Vertical F - F Line M - Multi+ M MF - Multi+ F Line Z - Multi+ Z T - Multi+ T 14D - Multi+ 14D MG - Mega Line	6 - Clamping C - With Clamping		7 - Insert Width [mm] (for IC5/8"V) 6, 8, 10						
8 - Tool Type CQ - Drop Head FQ - Off-Set Oil - For API Inserts	9 - RH/LH Holder None - Right Hand LH - Left Hand								

Internal Toolholders

C 1	A 2	VR 3	C 4	075 5	6	-	3 7	8	9	10	11	12
1 - Shank Type B - Anti Vibration System C - Carbide Shank S - Mini Holders		2 - Anvil A - Anvil Required N - No Anvil Required O - Miniature Holder		3 - Tool Type VR - Internal Round Shank		4 - Cooling C - With Coolant Channel			5 - Shank Front Dia. (Inch) 0375, 050, 0625, 075, 100, 125, 150, 200, 250 6.2 mm (Mini Adjust) 8.0 mm (Mini Adjust)		6 - Holder Length (Mini Holders) U - Ultra Short S - Short M - Medium L - Long T - Adjustable	
7 - Insert Size 5LK - IC5.0L mm 4.0K - IC4.0 mm 5.0K - IC5.0 mm 6.0K - IC6.0 mm 2 - IC1/4" 3 - IC3/8" 4 - IC1/2" 5 - IC5/8"		8 - Insert Style U - U style V - Vertical F - F Line M - Multi+ M MF - Multi+ F Line Z - Multi+ Z T - Multi+ T 14D - Multi+ 14D MG - Mega Line		9 - Clamping C - With Clamp		10 - Oil Field OIL - For API Inserts		11 - RH/LH Holder None - Right Hand LH - Left Hand				
12 - Serial No. 157/... (Coarse Pitch Holder) V6 (V6 Holder)												

Micro, Microscope & Adjustable Toolholders (Sleeves)

M 1	H 2	C 3	0750 4	-	4 5	-	4F 6				
1 - Holder Shape S - Sleeve (Double Ended) M - Microscope (Single Ended)		2 - Holder Type V - Adjustable Holders for Mini M - Micro (Double Ended) H - Microscope Holder HS - Microscope with Square Shank HD - Microscope with Drop Head		3 - Cooling C - Coolant Channel		4 - Shank Size [Inch] 0500, 0625, 0750, 1000		5 - Holder Bore Size [mm] Micro Size 3, 4, 5, 6, 7, 8, 10 Adjustable Holders (for Mini) 6.2, 8		6 - No. of Flats 4F - 4 Flats None - 2 Flats	

V-CAP Toolholders

VCAP	40	-	S	E	R	27	050	-	3
1	2		3	4	5	6	7		8

1 - Holder Style	2 - D (Polygon Size mm)	3 - Insert Style	4 - External / Internal	5 - RH / LH
VCAP - Vargus Polygon Shank	32, 40, 50, 63	S - Threading	E - External I - Internal	R - Right Hand L - Left Hand

6 - Cutting Radius	7 - Tool Overhang	8 - Insert Size
.47-2.17	1.57-4.13	3 - IC3/8"

VG-Cut Toolholders for Threading

VG	E	R	2525	-	3	T12
1	2	3	4		5	6

1 - Line Name	2 - Application Approach	3 - RH / LH	4 - Shank Size
VG - Deep Grooving & Parting Off	E - External	R - Right Hand L - Left Hand	Width-Height

5 - Pocket Size	6 - Depth of Cut
3	T12 - Limit Depth of Cut 12 mm

Mini-V Holders

C	V	08	-	12	21	-
1	2	3		4	5	6

1 - Holder Type	2 - Product Line	3 - Insert Style	4 - Shank Diameter	5 - Tool Overhang	6 - RH
C - Carbide Shank None - Steel Shank	V - Mini-V	08, 11, 14, 16	06 - .236" 08 - .315" 12 - .472" 16 - .630" 0500 - 500" 0625 - .625"	.827" - 3.150" 12 - 80mm	None - RH

Mini-V Sleeves

MH	C	0625	-	6
1	2	3		4

1 - Holder Type	2 - Cooling	3 - Shank Dia.	4 - Sleeve Bore Dia.
MH - Microscope Holder	C - Cooling Channels	12 - .472" 16 - .630" 0500 - .5" 0625 - 5/8" 0750 - 3/4"	.236" - .315"

External Toolholders

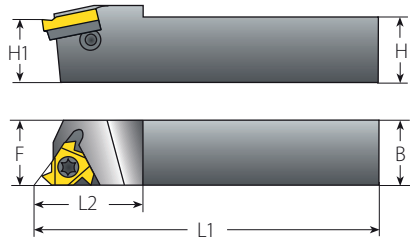
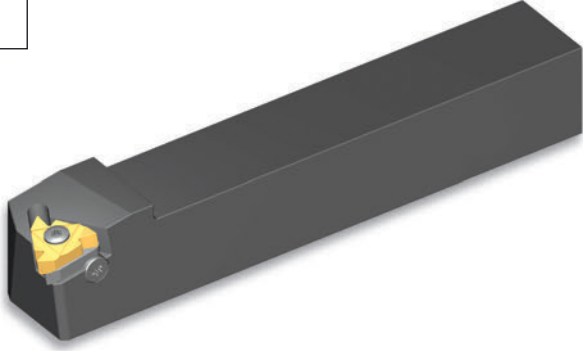
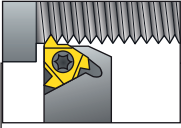

Standard

Spare Parts



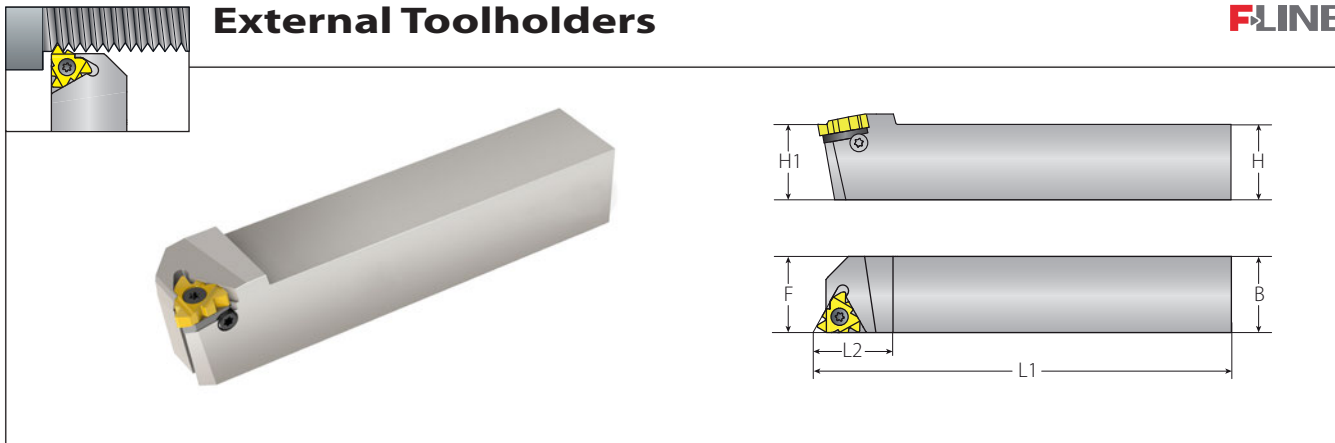

Insert Size	Ordering Code	EDP No.	Dimensions Inch				Insert Screw	Anvil Screw	Torx Key	Anvil RH	Anvil LH
IC	RH		H=H1=B	F	L1	L2					
1/4"	NL031-2	66214	.31	.43	5.37	.69	SN2T	-	K2T	-	-
	NL050-3	66220	.50	.63	3.27	.87	SA3T	-	K3T	-	-
3/8"	AL3/8-3	66091	.37	.63	2.45	.76	SA3T	SY3T	K3T	YE3	YI3
	AL050-3	66000	.50	.63	3.27	.87					
	AL0625-3	66005	.63	.63	5.00	1.02					
	AL075-3	66007	.75	.75	5.00	1.02					
	AL100-3	66016	1.00	1.00	6.00	1.20					
	AL125-3	66036	1.25	1.25	7.00	1.18					
1/2"	AL100-4	66024	1.00	1.00	6.00	1.42	SA4T	SY4T	K4T	YE4	YI4
	AL125-4	66042	1.25	1.25	7.00	1.42					
	AL150-4	66066	1.50	1.50	8.00	1.42					
5/8"	AL100-5	66034	1.00	1.25	6.00	1.57	SA5T	SY5T	K5T	YE5	YI5
	AL125-5	66051	1.25	1.25	7.00	1.57					
	AL150-5	66073	1.50	1.50	8.00	1.57					
	AL200-5	66085	2.00	2.00	1.00	1.57					

The above toolholders have a 1.5° helix angle. For other helix angles, see page 199.
 The above toolholders are for RH inserts. For LH inserts, add LH to the toolholder's ordering code (Example AL075-3**LH**).



Standard F-Line





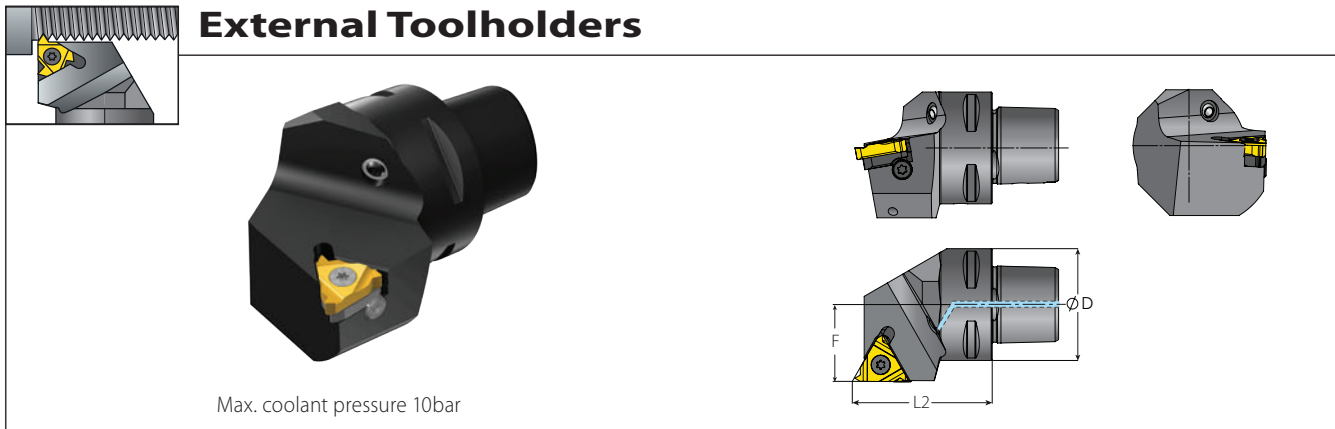

Spare Parts

Insert Size	Ordering Code	EDP No.	Dimensions Inch							
IC	RH		H=H1=B	F	L1	L2	Insert Screw	Anvil Screw	Torx Key	Anvil RH
1/2" F	AL100-4F	66660	1.00	1.00	6.00	1.30	SA4T	SY4T	K6T	YE4F
	AL125-4F	66661	1.25	1.25	7.00	1.30				
	AL150-4F	66662	1.50	1.50	8.00	1.30				



V-CAP

Spare Parts

Insert Size	Ordering Code	EDP No.	Dimensions Inch								
IC	RH		D mm	F	L2	Insert Screw	Anvil Screw	Torx Key	Coolant Jet	Anvil RH	Anvil LH
3/8"	VCAP32-SER22040-3	66717	32	.87	1.57	SA3T	SY3T	K3T	OD6	YE3	YI3
	VCAP40-SER27050-3	66165	40	1.06	1.97						
	VCAP50-SER35060-3	66166	50	1.38	2.36						
	VCAP63-SER45065-3	66167	63	1.77	2.56						

The above toolholders are for RH inserts. For LH inserts, add LH to the toolholder's ordering code (Example VCAP32-SEL22040-3).

The above toolholders have a 1.5° helix angle. For other helix angles, see page 199.

External Toolholders

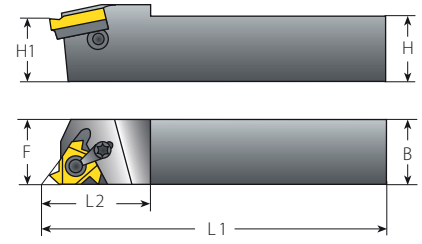
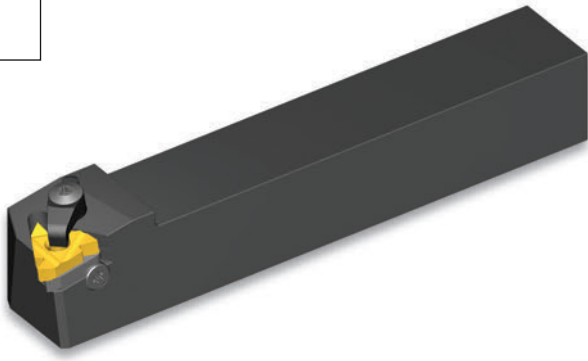
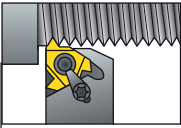

Standard with Clamp

(Dual System, Screw or Clamp)

Spare Parts

Insert Size	Ordering Code	EDP No.	Dimensions Inch				Spare Parts					
			H=H1=B	F	L1	L2	Insert Screw	Anvil Screw	Clamp	Torx Key	Anvil RH	Anvil LH
3/8"	AL075-3C	66008	.75	.75	5.00	1.20	SA3T	SY3T	C3	K3CT	YE3	YI3
	AL100-3C	66017	1.00	1.00	6.00	1.20						
	AL125-3C	66031	1.25	1.25	7.00	1.20						
1/2"	AL100-4C	66330	1.00	1.00	6.00	1.42	SA4T	SY4T	C4	K4T	YE4	YI4
	AL125-4C	66222	1.25	1.25	7.00	1.42						
	AL150-4C	66223	1.50	1.50	8.00	1.42						
5/8"	AL100-5C	66327	1.00	1.25	6.00	1.57	SA5T	SY5T	C5	K5T	YE5	YI5
	AL125-5C	66224	1.25	1.25	7.00	1.57						
	AL150-5C	66225	1.50	1.50	8.00	1.57						
	AL200-5C	66230	2.00	2.00	10.00	1.57						

The above toolholders have a 1.5° helix angle. For other helix angles, see page 199.
 The above toolholders are for RH inserts. For LH inserts, add LH to the toolholder's ordering code (Example AL075-3CLH).

External Toolholders

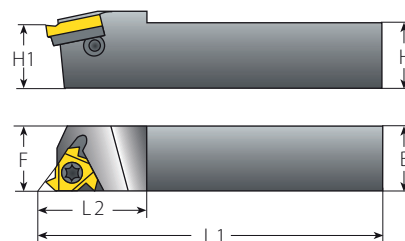
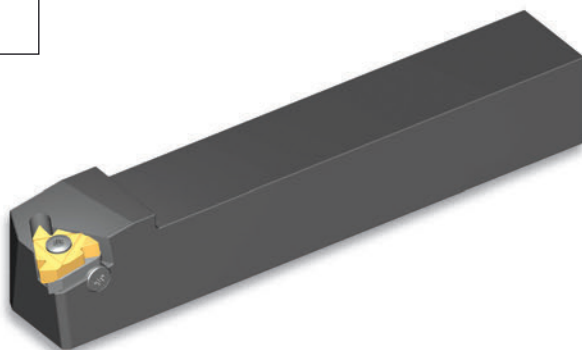

Oil & Gas

Spare Parts

Insert Size	Ordering Code	EDP No.	Thread Form	Connection No. or Size	Dimensions Inch			Helix Angle Deg.					
IC	RH				H=H1=B=F L1 L2				Insert Screw	Anvil Screw	Torx Key	Anvil RH	Anvil LH
3/8"	AL125-3 APIRD	66527	APIRD 8	2.375"-20"	1.25	7.00	1.30	1	SA3T	SY3T	K3T	YEI3 APIRD	
	AL150-3 APIRD	66528	APIRD10	1.05"-3.5"	1.50	8.00	1.60	1					
1/2"	AL125-45BUT/API	66532	5BUT, V0.038R, V0.050	4 1/2"-20"	1.25	7.00	1.30	0	SA4T	SY4T	K4T	YEI4-API-1P YEI4-5BUT	
	AL150-45BUT/API	66533	V0.040, V0.055	NC10-NC77 all sizes	1.50	8.00	1.60	0					
5/8"	AL125-5OIL	66058	V0.038R, V0.050	NC23-NC77 all sizes	1.25	7.00	1.60	1.5	SA5T	SY5T	K5T	YE5OIL	YI5OIL
	AL150-5OIL	66075	V0.038R, V0.050	NC23-NC77 all sizes	1.50	8.00	1.60	1.5					

The above toolholders are for RH inserts. For LH inserts, add LH to the toolholder's ordering code (Example AL150-5OIL LH)

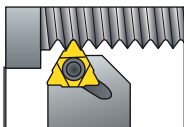

External Toolholders

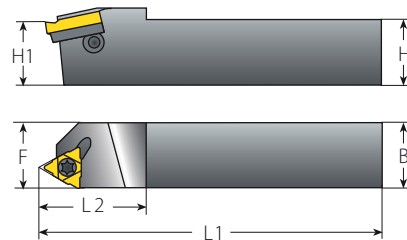
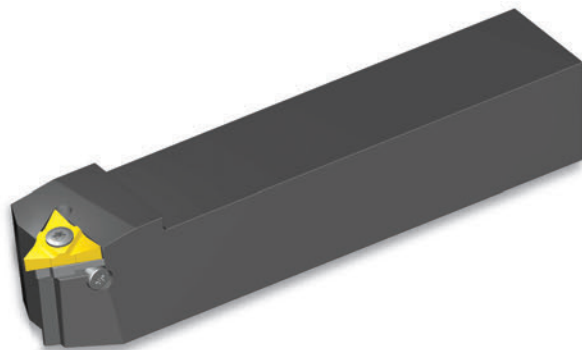

U Style

Insert Size	Ordering Code	EDP No.	Dimensions Inch			
IC	RH		H=H1=B	F	L1	L2
1/2"U	AL125-4U	66048	1.25	1.25	7.00	1.52
	AL150-4U	66247	1.50	1.50	8.00	1.52
5/8"U	AL125-5U	66059	1.25	1.25	7.00	1.57
	AL150-5U	66076	1.50	1.50	8.00	1.57
	AL200-5U	66249	2.00	2.00	10.00	1.57

Spare Parts

Insert Screw	Anvil Screw	Torx Key	Anvil RH	Anvil LH
SA4T	SY4T	K4T	YE4U	YI4U
SA5T	SY5T	K5T	YE5U	YI5U

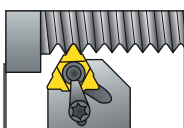

External Toolholders

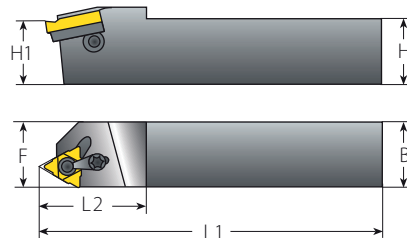
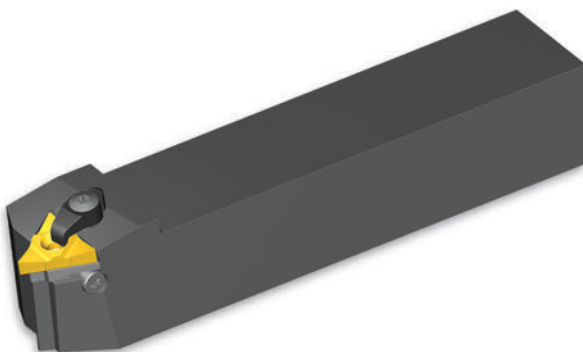

U Style with Clamp

(Dual System, Screw or Clamp)

Insert Size	Ordering Code	EDP No.	Dimensions Inch			
IC	RH		H=H1=B	F	L1	L2
1/2"U	AL125-4UC	66250	1.25	1.25	7.00	1.52
	AL150-4UC	66251	1.50	1.50	8.00	1.52
5/8"U	AL125-5UC	66252	1.25	1.25	7.00	1.57
	AL150-5UC	66253	1.50	1.50	8.00	1.57
	AL200-5UC	66256	2.00	2.00	10.00	1.57

Spare Parts

Insert Screw	Anvil Screw	Clamp	Torx Key	Anvil RH	Anvil LH
SA4T	SY4T	C4	K4T	YE4U	YI4U
SA5T	SY5T	C5	K5T	YE5U	YI5U

All U Style Toolholders have a 1.5° helix angle. For other helix angles see page 199. The above toolholders are for RH inserts. For LH inserts, add LH to the toolholder's ordering code (Example AL100-4ULH).

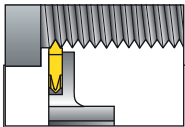

External Toolholders

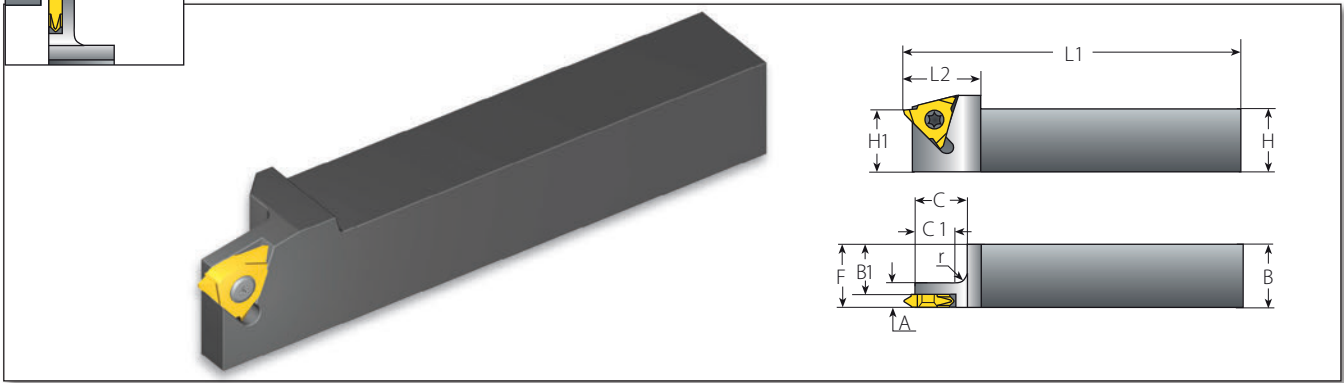

Slim Throat

Insert Size		Ordering Code	EDP No.	Dimensions Inch								Spare Parts	
IC	RH		H=B=F	H1	A	B1	C	C1	L1	L2	r	Insert Screw	Torx Key
1/4"V	NL0315-2V	66257	.31	.39	.28	.19	.50	.45	2.50	.60	.04	SN2T	K2T
	NL0375-2V	67226	.37	.37	.27	.25	.50	.45	2.75	.60	.04		
	NL050-2V	67232	.50	.50	.27	.37	.57	.45	3.15	.60	.12		
	NL0625-2V	67229	.62	.62	.27	.50	.57	.45	4.00	.60	.12		
3/8"V	NL0625-3V	67201	.62	.62	.27	.47	.57	.45	4.00	1.00	.12	SN3TV	K3T
	NL075-3V	67203	.75	.75	.27	.60	.65	.45	5.00	1.20	.12		
	NL100-3V	67205	1.00	1.00	.27	.85	.65	.45	6.00	1.20	.20		
	NL125-3V	66258	1.25	1.25	.27	1.20	.65	.45	7.00	1.20	.20		
1/2"V	NL150-3V	66259	1.50	1.50	.28	1.25	.65	.45	8.00	1.20	.20	SN4T	K4T
	NL100-4V	66221	1.00	1.00	.47	.81	.65	.45	6.00	1.20	.20		
	NL125-4V	66263	1.25	1.25	.47	1.07	.65	.45	7.00	1.20	.20		
	NL150-4V	66266	1.50	1.50	.47	1.31	.65	.45	8.00	1.20	.20		

All Slim Throat toolholders have a 1.5° helix angle see page 199.
 The above toolholders are for RH inserts. For LH inserts, add LH to the toolholder's ordering code (Example NL0325-2VLH).

External Toolholders

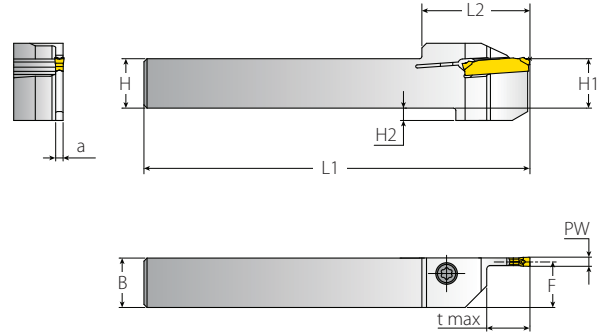
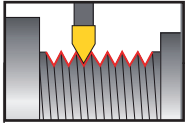

Thread Turning Toolholders

Monoblock

Spare Parts

Ordering Code		Dimensions Inch								Spare Parts	
RH/LH	PW	t max	HxB	H1	F	L1	L2	a	H2	Cylindrical Holder Screw	Torx Key
VGER/L0625-3T12			.625X.625	.625	.578				0.162		
VGER/L075-3T12	.118	.472	.750X.750	.750	.703	5.00	1.38	.09	-	SM4,0X18-T20	K6T
VGER/L100-3T12			1.00X1.00	1.000	.953				-		

External Toolholders

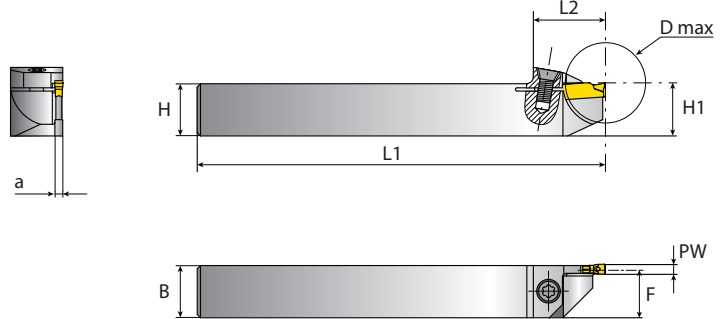
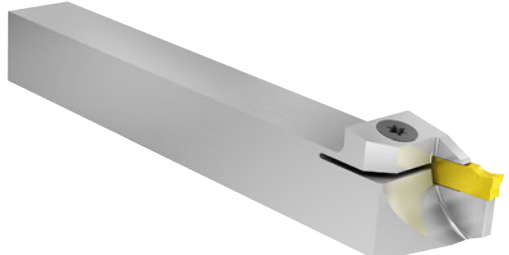
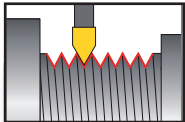

Reinforced Monoblock

Spare Parts

Ordering Code		Dimensions Inch								Spare Parts	
RH/LH	PW	D max	HxB	H1	F	L1	L2	a	Cylindrical Holder Screw	Torx Key	
VGER/L0625-3T12PH		1.02	.625X.625	.625	.578		.87				
VGER/L075-3T21PH	.118	1.65	.750X.750	.750	.703	5.00	1.18	.09	SCM4X14	KT-15	
VGER/L100-3T21PH		1.65	1.00X1.00	1.000	.953		1.18				

All VG-Cut tooling have 1.5° helix angle.

External Toolholders

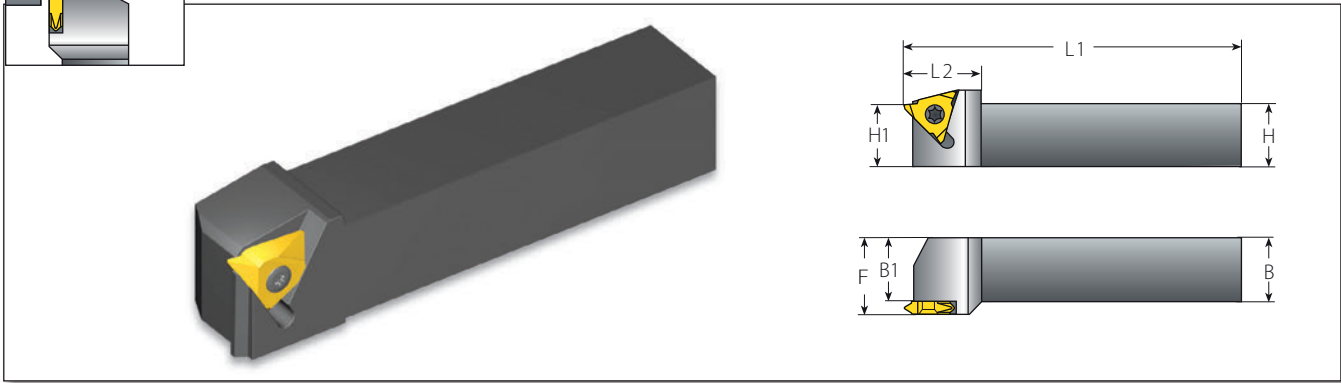

V Style

Insert Size	Ordering Code	EDP No.	Dimensions Inch					Spare Parts	
IC	RH		H=H1=B	B1	F	L1	L2	Insert Screw	Torx key
5/8"V	NL125-5V-6	67213	1.25	1.00	1.25	7.00	1.57	SN6T	K6T
	NL125-5V-8	67214	1.25	1.00	1.33	7.00	1.57		
	NL125-5V-10	67212	1.25	1.00	1.40	7.00	1.57		
	NL125-5V-10ABUT*	66382	1.25	1.00	1.40	7.00	1.57		
	NL150-5V-6	66383	1.50	1.24	1.50	8.00	1.57		
	NL150-5V-8	66384	1.50	1.24	1.63	8.00	1.57		
	NL150-5V-10	67215	1.50	1.24	1.65	8.00	1.57		
	NL150-5V-10ABUT*	66385	1.50	1.24	1.65	8.00	1.57		

All V Style toolholders have a 1° helix angle.
 The above toolholders are for RH inserts. For LH inserts, add LH to the toolholder's ordering code (Example NL125-5V-6 LH).

* To be used only with inserts 5VER2.5ABUT...

External Toolholders

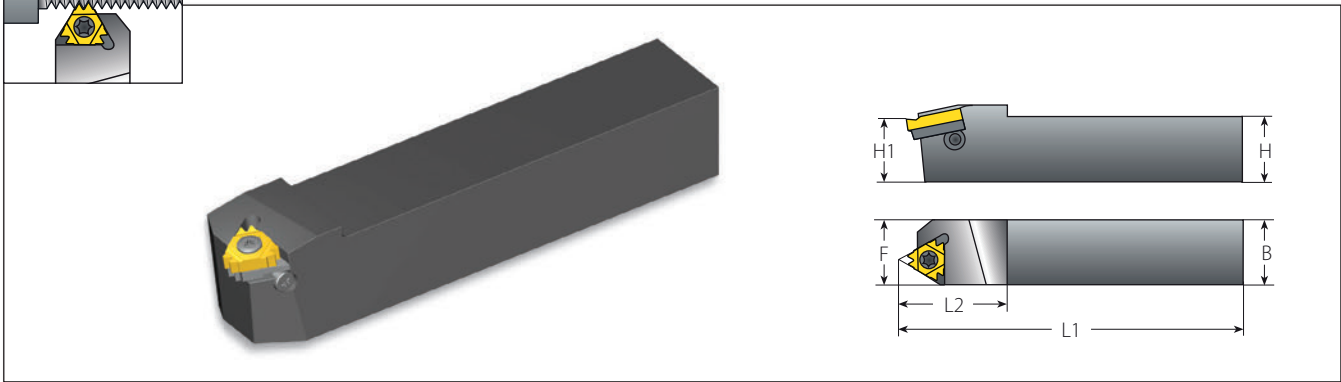

Z+ Style

Insert Size	Ordering Code	Dimensions Inch					Spare Parts				
IC	RH	H=H1=B	F	L1	L2	Insert Screw	Anvil Screw	Torx Key	Anvil RH	Anvil LH	
1/2"Z	AL125-4Z	66386	1.25	1.25	7.00	1.52	SA4T	SY4T	K4T	YE4Z	YI4Z
	AL150-4Z	66387	1.50	1.50	8.00	1.52					
5/8"Z	AL125-5Z	66388	1.25	1.25	7.00	1.57	SA5T	SY5T	K5T	YE5Z	YI5Z
	AL150-5Z	66389	1.50	1.50	8.00	1.57					
	AL200-5Z	66390	2.00	2.00	10.00	1.57					

All Z Style toolholders have a 1.5° helix angle.



External Toolholders

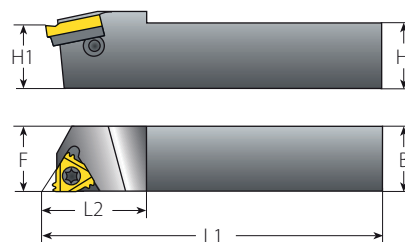
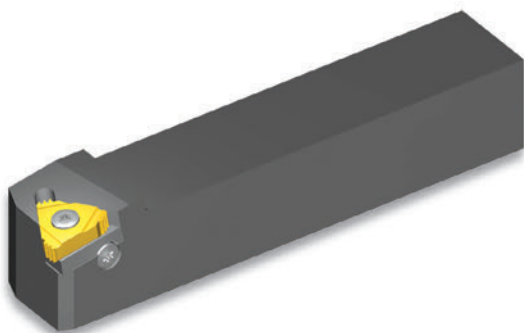

M+ Style

Spare Parts



Insert Size	Ordering Code	EDP No.	Dimensions Inch				Insert Screw	Anvil Screw	Torx Key	Anvil RH	Anvil LH
IC	RH		H=H1=B	F	L1	L2					
5/8" M	AL125-5M	66391	1.25	1.25	7.00	1.57	SA5T	SY5T	K5T	YE5M	YI5M
	AL150-5M	66392	1.50	1.50	8.00	1.57					
	AL200-5M	66393	2.00	2.00	10.00	1.57					

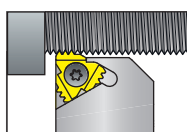

External Toolholders

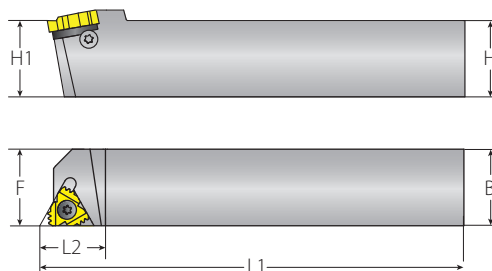

F-Line M+ Style

Spare Parts



Insert Size	Ordering Code	EDP No.	Dimensions Inch				Insert Screw	Anvil Screw	Torx Key	Anvil RH
IC	RH		H=H1=B	F	L1	L2				
1/2" F	AL100-4MF	66714	1.00	1.00	6.10	1.30	SA4T	SY4T	K6T	YE4M2F
	AL125-4MF	66663	1.25	1.25	7.00	1.30				
	AL150-4MF	66664	1.50	1.50	8.00	1.30				



The above toolholders have a 1.5° helix angle. For other helix angles, see page 199.

External Toolholders

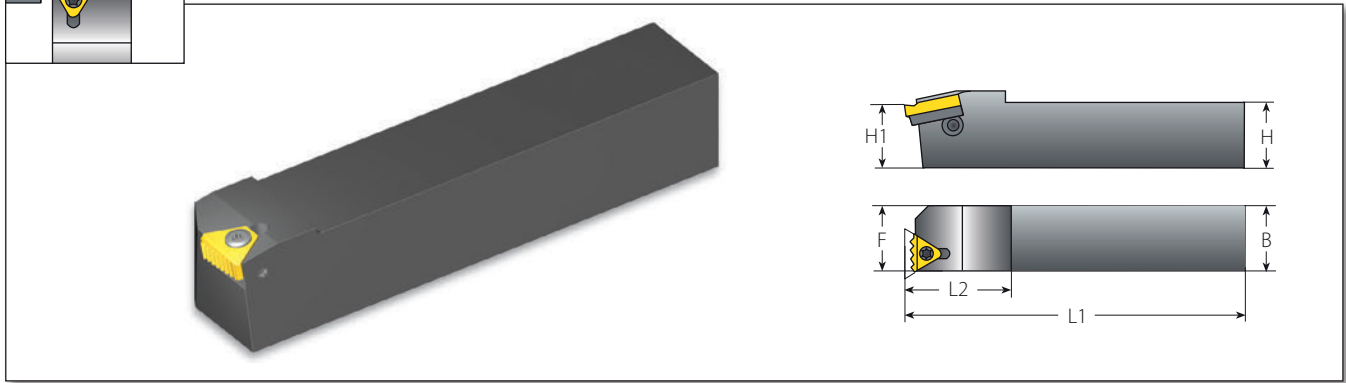

T+ Style						Spare Parts Multiplus					
Insert Size	Ordering Code	EDP No.	Dimensions Inch								
IC	RH		H=H1=B	F	L1	L2	Insert Screw	Anvil Screw	Insert Torx Key	Anvil Torx Key	Anvil RH/LH
1/2" T	AL100-4T	66334	1.00	1.08	6.00	1.20	SA4T	SY4K2	K4T	K2	Y4T
	AL125-4T	66394	1.25	1.33	7.00	1.20					
	AL150-4T	66395	1.50	1.58	8.00	1.20					

All T Style toolholders have a 0° helix angle.

External Toolholders

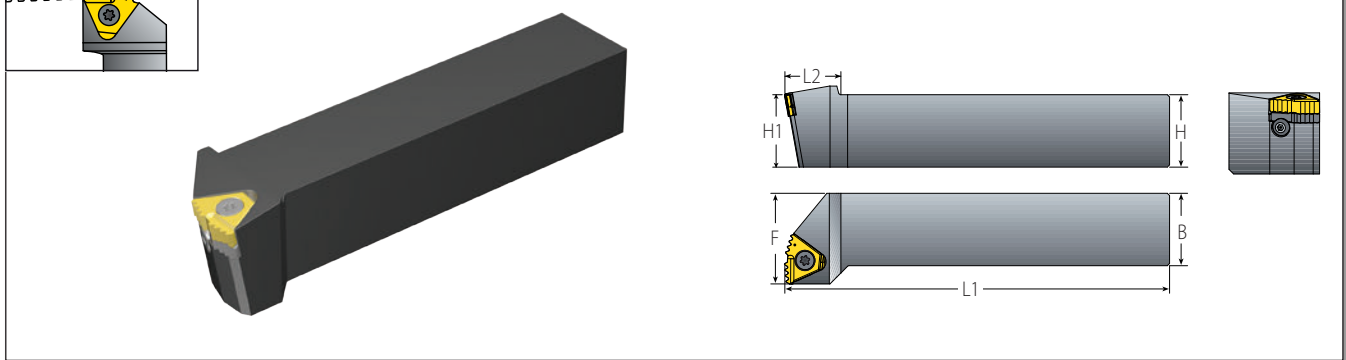

14D Standard						Spare Parts Multiplus			
Insert Size	Ordering Code	Dimensions Inch							
IC	RH	H=H1=B	F	L1	L2	Insert Screw	Anvil Screw & Washer	Torx Key	Anvil Key
14D	AL100-14D	1.00	1.75	5.80	1.00	SA5T	M4x6(14D)	KT15	K5T
	AL125-14D	1.25	1.50	7.00	1.00				
	AL150-14D	1.50	1.50	8.00	1.25				

14D holders are supplied without anvils. For specific applications, please use the anvils indicated in the table on page 199.

External Toolholders

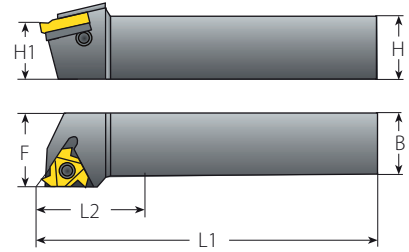
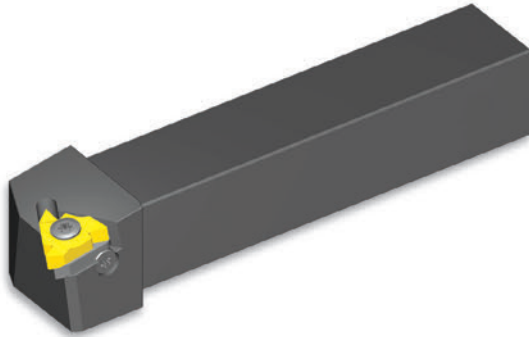
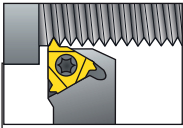

Off-Set Qualified (FQ)

Spare Parts

Insert Size	Ordering Code	EDP No.	Dimensions Inch								
IC	RH	H=H1=B	F	L1	L2	Insert Screw	Anvil Screw	Torx Key	Anvil RH	Anvil LH	
3/8"	AL075-3FQ	66011	.75	1.00	6.00	1.00	SA3T	SY3T	K3T	YE3	YI3
	AL100-3FQ	66020	1.00	1.25	6.00	1.00					
	AL125-3FQ	66039	1.25	1.50	6.00	1.20					
1/2"	AL100-4FQ	66027	1.00	1.25	6.00	1.20	SA4T	SY4T	K4T	YE4	YI4
	AL125-4FQ	66045	1.25	1.50	6.00	1.20					
5/8"	AL125-5FQ	66053	1.25	1.50	6.00	1.20	SA5T	SY5T	K5T	YE5	YI5

External Toolholders

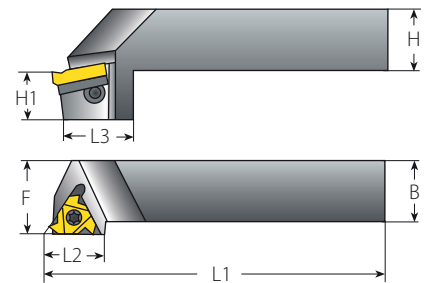
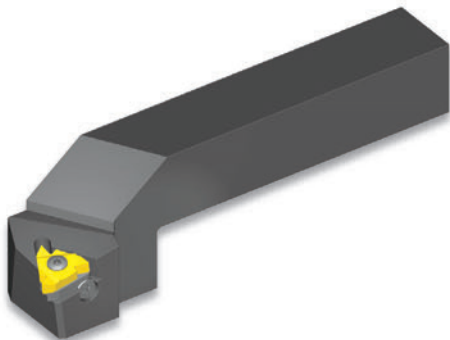
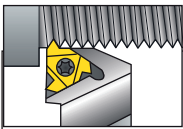

Drop Head-Qualified (CQ)

Spare Parts

Insert Size	Ordering Code	EDP No.	Dimensions Inch										
IC	RH	H=B	F	L1	L2	L3	H1	Insert Screw	Anvil Screw	Torx Key	Anvil RH	Anvil LH	
3/8"	AL075-3CQ	66009	.75	1.00	5.00	.88	1.50	SA3T	SY3T	K3T	YE3	YI3	
	AL100-3CQ	66018	1.00	1.25	6.00	.88	1.50						.87
	AL125-3CQ	66037	1.25	1.50	7.00	.88	1.50						.87
1/2"	AL100-4CQ	66025	1.00	1.25	6.00	1.13	1.50	SA4T	SY4T	K4T	YE4	YI4	
	AL125-4CQ	66043	1.25	1.50	7.00	1.13	1.50						.87
5/8"	AL125-5CQ	66052	1.25	1.50	7.00	1.25	1.69	1.00	SA5T	SY5T	K5T	YE5	YI5

The above toolholders have a 1.5° helix angle. For other helix angles see page 199.
The above toolholders are for RH inserts. For LH inserts, add LH to the toolholder's ordering code (Example AL075-3FQLH).

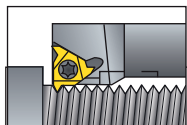

External + Internal Toolholders

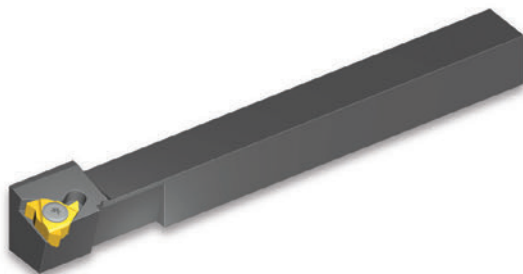

Miniature Square Shank*

Insert Size	Ordering Code	EDP No.	Dimensions Inch					Min. Bore Dia.	Spare Parts	
			IC	RH	A	L	L1 (max)		F	Inch
1/4"	OV8-2	66282	.31	3.94	1.00	.47	1.15	SN2T	K2T	
	OV10-2	66280	.39	3.94	1.00	.55	1.42			

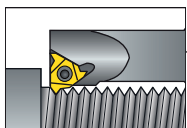

External + Internal Toolholders

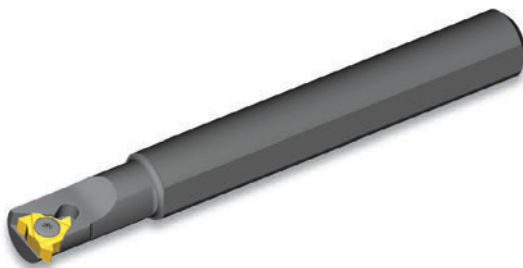

Miniature Round Shank*

Insert Size	Ordering Code	EDP No.	Dimensions Inch							Min. Bore Dia.	Spare Parts	
			IC	RH	A	L	L1 (max)	D	D1		F	Inch
1/4"	OVR12-2	66272	.45	3.94	.98	.47	.39	.29	.51	SN2T	K2T	
	OVR15-2	66274	.56	3.94	1.26	.59	.51	.35	.63			
	OVR16D-2	66217	.60	3.94	1.26	.63	.51	.35	.63			

* Miniature square and round toolholders are designed for use on automatic lathes for the optical and other precision industries. They can be used for both external and internal threading, as follows:

Thread	ER	EL	IR	IL
Insert	ER	EL	IR	IL
Holder	LH	RH	RH	LH

Miniature toolholders have a 0.5° helix angle.
The above toolholders are for RH inserts. For LH inserts, add LH to the toolholder's ordering code (Example OV8-2LH).

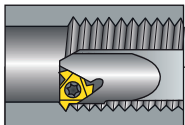

Internal Toolholders

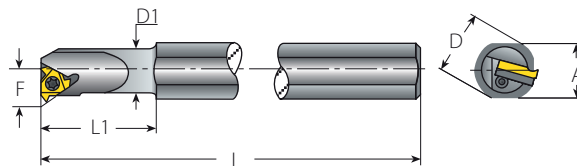
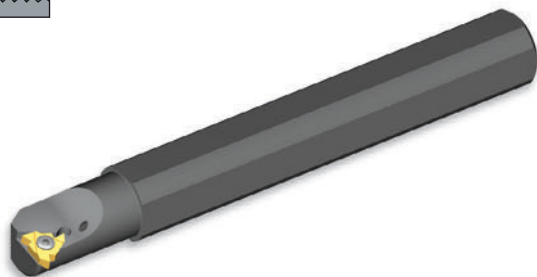

Standard

Spare Parts

Insert Size	Ordering Code	Dimensions Inch								Min. Bore Dia.	Spare Parts				
IC	RH	EDP No.	A	L	L1 (max)	D	D1	F	Inch		Insert Screw	Anvil Screw	Torx Key	Anvil RH	Anvil LH
1/4"	NVRC0375D-2	66234	.67	7.00	1.00	.75	.37	.28	.50		SN2T	-	K2T	-	-
	NVRC050-2	66236	.67	7.00	1.25	.75	.50	.37	.65						
3/8"	NVRC050-3	66238	.67	7.00	1.25	.75	.62	.40	.67		SN3T	-	K3T	-	-
	NVRC0625-3	66240	.67	7.00	1.50	.75	.62	.46	.80						
	NVRC0625D-3	66242	.58	6.00	2.48	.625	.62	.46	.80						
	AVRC075-3	66098	.67	7.00	3.00	.75	.75	.51	.90						
	AVRC100-3	66100	1.12	10.00	2.50	1.25	1.00	.65	1.20						
3/8"	AVRC100D-3	66104	.89	8.00	4.00	1.00	1.00	.65	1.20		SA3T	SY3T	K3T	Y13	YE3
	AVRC125-3	66108	1.12	10.00	5.00	1.25	1.25	.77	1.45						
	AVRC150-3	66114	1.34	12.00	6.00	1.50	1.50	.90	1.65						
	AVRC200-3	66294	1.80	14.00	8.00	2.00	1.99	1.10	2.22						
1/2"	NVRC075-4	66244	.67	7.00	3.00	.75	.75	.59	1.00		SN4T	-	K4T	-	-
	AVRC100-4	66102	1.12	10.00	2.50	1.25	1.00	.71	1.25						
	AVRC100D-4	66106	.89	8.00	4.00	1.00	1.00	.71	1.25		SA4T	SY4T	K4T	Y14	YE4
	AVRC125-4	66110	1.12	10.00	5.00	1.25	1.25	.85	1.50						
	AVRC150-4	66116	1.34	12.00	6.00	1.50	1.50	.98	1.75						
5/8"	AVRC200-4	66715	1.80	14.00	8.00	2.00	2.00	1.22	2.17						
	AVRC125-5	66112	1.12	10.00	5.00	1.25	1.25	.88	1.55		SN5T	SY5T	K5T	Y15	YE5
	AVRC150-5	66118	1.34	12.00	6.00	1.50	1.50	1.00	1.80						
	AVRC200-5	66120	1.80	14.00	8.00	2.00	2.00	1.25	2.30		SA5T	SY5T	K5T	Y15	YE5
5/8"	AVRC250-5	66123	2.26	16.00	10.00	2.50	2.50	1.50	2.80						

- The above toolholders have a 1.5° helix angle. For other helix angles, see page 199.
- Toolholders with prefix "N" cannot be used with an anvil.
- Holders with coolant channel are available as standard (Example NVRC0375D-2).
- The above toolholders are for RH inserts. For LH inserts, add LH to the toolholder's ordering code (Example NVR0375D-2**LH**).

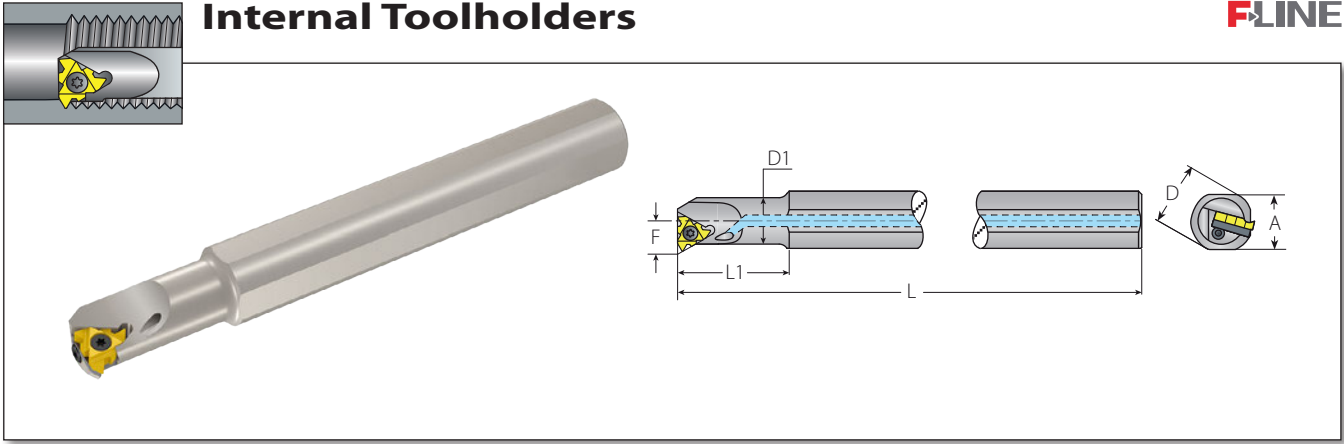

Standard F-Line

Spare Parts

Insert Size	Ordering Code	EDP No.	Dimensions Inch							Min. Bore Dia.	Spare Parts			
IC	RH	A	L	L1 (max)	D	D1	F	Inch		Insert Screw	Anvil Screw	Torx Key	Anvil RH	
1/2" F	AVRC100-4F	66665	1.12	10.0	2.50	1.25	1.00	.64	1.25	SA4T	SY4T	K6T	Y14F	
	AVRC100D-4F	66672	.89	8.0	4.00	1.00	1.00	.64	1.25					
	AVRC125-4F	66666	1.12	10.0	5.00	1.25	1.25	.76	1.50					
	AVRC150-4F	66667	1.34	12.0	6.00	1.50	1.50	.90	1.75					
	AVRC200-4F	66716	1.80	14.00	8.00	2.00	2.00	1.22	2.17					

The above toolholders have a 1.5° helix angle. For other helix angles, see page 199.

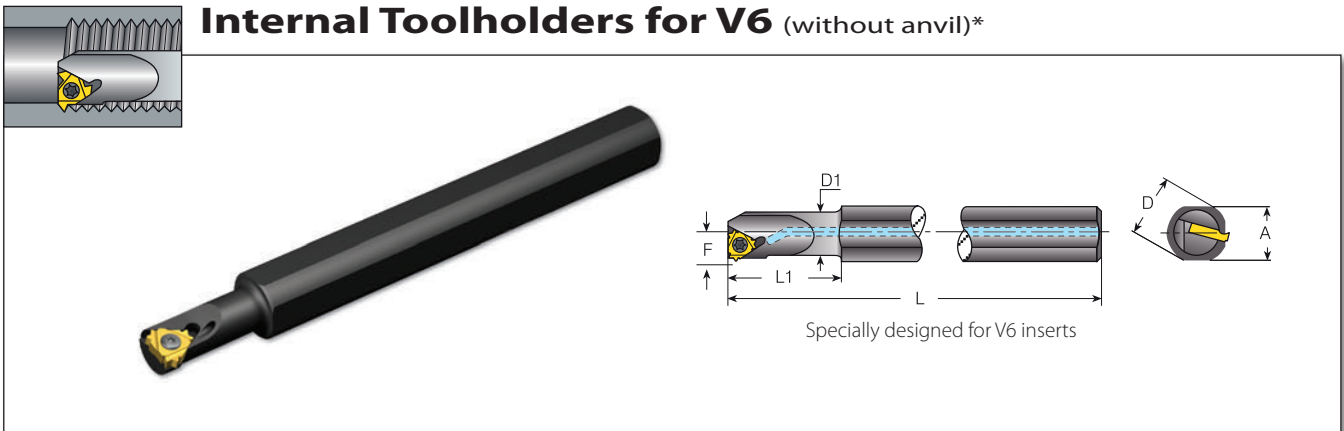

V6 Style

Spare Parts



Insert Size	Ordering Code	EDP No.	Dimensions Inch							Min. Bore Dia.	Spare Parts	
IC	RH	A	L	L1 (max)	D	D1	F	Inch		Insert Screw	Torx Key	
3/8" V6	NVRC050-3V6	66231	.67	7.00	1.25	.75	.50	.40	.67	SN3TM	K3T	
	NVRC0625-3V6	66232	.67	7.00	1.50	.75	.62	.46	.80			
	NVRC0625D-3V6	66233	.58	6.00	2.48	.625	.62	.46	.80			

* V6 inserts cannot be used on standard internal toolholders without anvil. For this purpose you must use one of these special V6 toolholders. The above toolholders have a 1.5° helix angle.

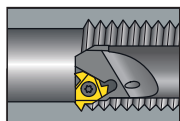

Internal Toolholders

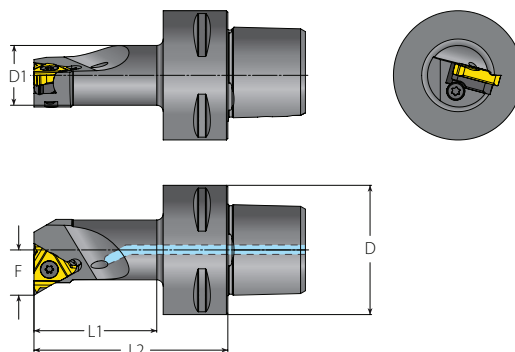

V-CAP



Insert Size	Ordering Code	EDP No.	Dimensions Inch					Min. Bore Dia.	Spare Parts				
			IC	RH	D1	D mm	F		L2	L1 (max)	Inch	Insert Screw	Anvil Screw
3/8"	VCAP40-SIR12060-3	66169	.61	40	.47	2.36	1.46	.79	SN3T	-	K3T	-	-
	VCAP40-SIR14060-3	66170	.73		.55	2.36	1.50	.98	SA3T	SY3T	K3T	Y13	YE3
	VCAP40-SIR17070-3	66171	.96		.67	2.76	1.89	1.26					
	VCAP40-SIR22090-3	66172	1.26		.87	3.54	2.72	1.57					
	VCAP40-SIR27080-3	66175	1.56	1.06	3.15	2.36	1.97						
	VCAP50-SIR12060-3	66176	.61	50	.47	2.36	1.38	.79	SN3T	-	K3T	-	-
	VCAP50-SIR14060-3	66177	.73		.55	2.36	1.42	.98	SA3T	SY3T	K3T	Y13	YE3
	VCAP50-SIR17070-3	66178	.96		.67	2.76	1.85	1.26					
	VCAP50-SIR22090-3	66718	1.26		.87	3.54	2.68	1.57					
	VCAP50-SIR27105-3	66180	1.57	1.06	4.13	3.31	1.97						
	VCAP63-SIR14070-3	66181	.73	63	.55	2.76	1.65	.98	SA3T	SY3T	K3T	Y13	YE3
	VCAP63-SIR17075-3	66182	.96		.67	2.95	1.89	1.26					
VCAP63-SIR22090-3	66184	1.26	.87		3.54	2.52	1.57						
VCAP63-SIR27105-3	66168	1.57	1.06		4.13	3.15	1.97						

The above toolholders have a 1.5° helix angle. For other helix angles, see page 199.
The above toolholders are for RH inserts. For LH inserts, add LH to the toolholder's ordering code (Example VCAP40-SIR12060-3).

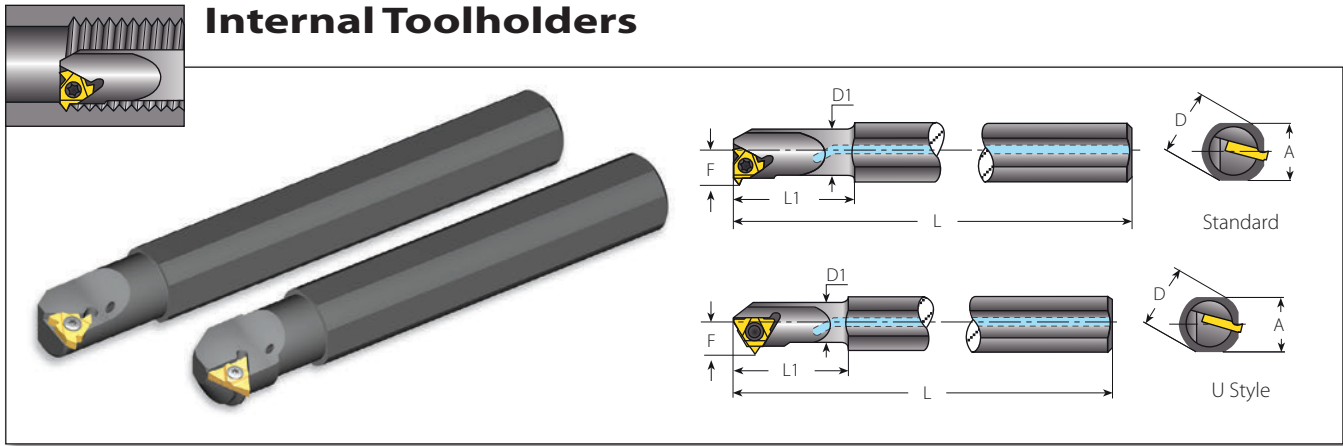

Internal Toolholders



Standard for Coarse Pitch

Standard for Coarse Pitch											Spare Parts			
Insert Size		Ordering Code				Dimensions Inch					F to Insert	Holder Helix		
IC	RH	EDP No.	LH	EDP No.	A	L	L1 (max)	D	D1	Inch	Deg.	Insert Screw	Torx Key	
1/4"	NVRC040-2-157/001	66297	NVRC040-2LH-157/025	66717	.67	7.00	.98	.75	.40	.26	3.0	SN2T	K2T	
	NVRC044-3-157/005	66301	NVRC044-3LH-157/029	66718	.67	7.00	1.00	.75	.44	.33	4.5	SN3TM	K3T	
3/8"	NVRC050-3-157/006	66302	NVRC050-3LH-157/030	66685	.67	7.00	1.26	.75	.51	.36	4.0	SN3T	K3T	
	NVRC050-3-157/016	66322	NVRC050-3LH-157/035	66686	.67	7.00	1.26	.75	.54	.35	2.5			
1/2"	NVRC067-4-157/007	66303	NVRC067-4LH-157/022	66719	.67	7.00	1.57	.75	.66	.45	4.0	SN4TM	K4T	
	NVRC067-4-157/039	66721	NVRC067-4LH-157/040	66720	.67	7.00	1.60	.75	.65	.53	4.0			
	NVRC075-4-157/008	66304	NVRC075-4LH-157/017	66687	.67	7.00	1.97	.75	.77	.49	3.5	SN4T	K4T	
	NVRC075-4-157/009	66305	NVRC075-4LH-157/021	66308	.67	7.00	1.97	.75	.77	.49	3.0			
5/8"	NVRC100-5-157/012	66362	NVRC100-5LH-157/031	66688	1.12	10.00	2.36	1.25	.98	.66	3.3	SN5TM	K5T	
	NVRC110-5-157/010	66306	NVRC110-5LH-157/023	66323	1.12	10.00	1.97	1.25	1.10	.70	3.5			

U Style for Coarse Pitch

U Style for Coarse Pitch											Spare Parts			
Insert Size		Ordering Code				Dimensions Inch					F to Insert	Holder Helix		
IC	RH	EDP No.	LH	EDP No.	A	L	L1 (max)	D	D1	Inch	Deg.	Insert Screw	Torx Key	
6.0U	NVRC032-6.0KU-157/003	66299	NVRC032-6.0KULH-157/027	66722	.67	7.00	.94	.75	.31	.23	4.0	SN6MTN	KIP6	
1/4"U	NVRC039-2U-157/004	66300	NVRC039-2ULH-157/028	66723	.67	7.00	1.26	.75	.39	.29	4.0	SM2T8	K2T	
	NVRC044-2U-157/002	66298	NVRC044-2ULH-157/026	66724	.67	7.00	1.26	.75	.44	.29	3.0			
3/8"U	NVRC044-3U-157/020	66420	NVRC044-3ULH-157/038	66725	.67	7.00	1.26	.75	.43	.32	4.5			
	NVRC055-3U-157/018	66396	NVRC055-3ULH-157/036	66726	.67	7.00	1.50	.75	.53	.39	4.5	SN3TM	K3T	
	NVRC059-3U-157/019	66363	NVRC059-3ULH-157/037	66433	.67	7.00	1.50	.75	.61	.43	4.0			
1/2"U	NVRC075-4U-157/011	66329	NVRC075-4ULH-157/024	66430	.67	7.00	1.57	.75	.76	.54	4.0	SN4T	K4T	
	NVRC100-4U-157/013	66360	NVRC100-4ULH-157/032	66689	1.12	10.00	2.36	1.25	.98	.69	3.5			
	NVRC125-4U-157/014	66136	NVRC125-4ULH-157/033	66690	1.12	10.00	2.36	1.25	1.17	.74	3.3	SA4T	K4T	
5/8"U	NVRC125-5U-157/015	66361	NVRC125-5ULH-157/034	66691	1.12	10.00	2.36	1.25	1.24	.83	3.2	SN5T	K5T	

Internal Toolholders

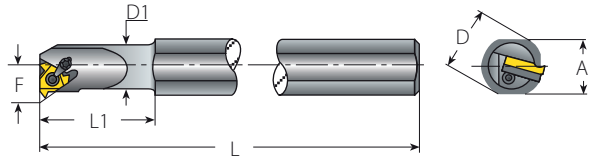
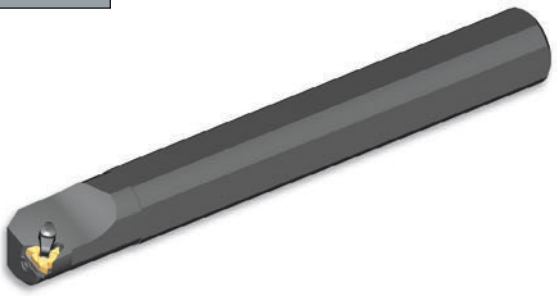
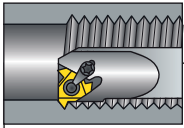

Standard with Clamp

(Dual System, Screw or Clamp)

Spare Parts

Insert Size	Ordering Code	EDP No.	Dimensions Inch							Min. Bore Dia.	Spare Parts					
			IC	RH	A	L	L1 (max)	D	D1		F	Inch	Insert Screw	Anvil Screw	Clamp	Torx Key
3/8"	AVR075-3C	66130	.67	7.00	3.00	.75	.75	.51	.94							
	AVR100-3C	66397	1.12	10.00	2.50	1.25	1.00	.65	1.20							
	AVR100D-3C	66132	.90	8.00	4.00	1.00	1.00	.65	1.20	SA3T	SY3T	C3	K3CT	YI3	YE3	
	AVR125-3C	66398	1.12	10.00	5.00	1.25	1.25	.77	1.45							
1/2"	AVR150-3C	66399	1.34	12.00	6.00	1.50	1.50	.90	1.65							
	AVR100-4C	66400	1.12	10.00	2.50	1.25	1.00	.71	1.25							
	AVR100D-4C	66401	.90	8.00	4.00	1.00	1.00	.71	1.25	SA4T	SY4T	C4	K4T	YI4	YE4	
	AVR125-4C	66402	1.12	10.00	5.00	1.25	1.25	.85	1.50							
5/8"	AVR150-4C	66403	1.34	12.00	6.00	1.50	1.50	.98	1.75							
	AVR125-5C	66404	1.12	10.00	5.00	1.25	1.25	.88	1.55	SN5T	SY5T	C5	K5T	YI5	YE5	
	AVR150-5C	66405	1.34	12.00	6.00	1.50	1.50	1.00	1.80							
	AVR200-5C	66406	1.80	14.00	8.00	2.00	2.00	1.25	2.30	SA5T	SY5T	C5	K5T	YI5	YE5	
	AVR250-5C	66407	2.26	16.00	10.00	2.50	2.50	1.50	2.80							

- The above toolholders have a 1.5° helix angle. For other helix angles, see page 199.
- Holders with coolant channel available as standard (Example AVR075-3C).
- The above toolholders are for RH inserts. For LH inserts, add LH to the toolholder's ordering code (Example AVR075-3CLH).

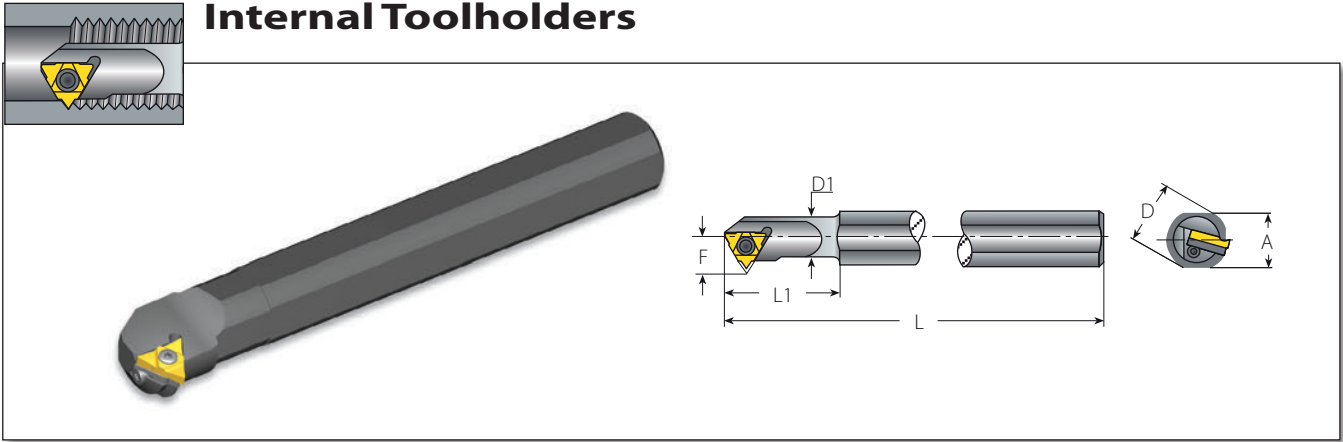

U Style

Spare Parts

Insert Size	Ordering Code	EDP No.	Dimensions Inch						Min. Bore Dia.					
			IC	RH	A	L	L1 (max)	D		D1	F	Inch	Insert Screw	Anvil Screw
1/2"U	AVR125-4U	66421	1.12	10.00	5.00	1.25	1.25	1.01	1.65	SA4T	SY4T	K4T	YI4U	YE4U
	AVR150-4U	66156	1.34	12.00	6.00	1.50	1.50	1.12	1.90					
5/8"U	NVR125-5U	66264	1.12	10.00	5.00	1.25	1.25	.98	1.65	SN5T	-	K5T	-	-
	AVR150-5U	66162	1.34	12.00	6.00	1.50	1.50	1.13	1.90					
	AVR200-5U	66179	1.80	14.00	8.00	2.00	2.00	1.37	2.40	SA5T	SY5T	K5T	YI5U	YE5U
	AVR250-5U	66187	2.26	16.00	10.00	2.50	2.50	1.31	2.90					

- The above toolholders have a 1.5° helix angle. For other helix angles, see page 199.
- Holders with coolant channel available as standard (Example AVRC125-4U).
- The above toolholders are for RH inserts. For LH inserts, add LH to the toolholder's ordering code (Example AVR125-4ULH).

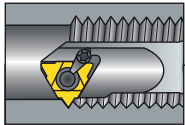

Internal Toolholders

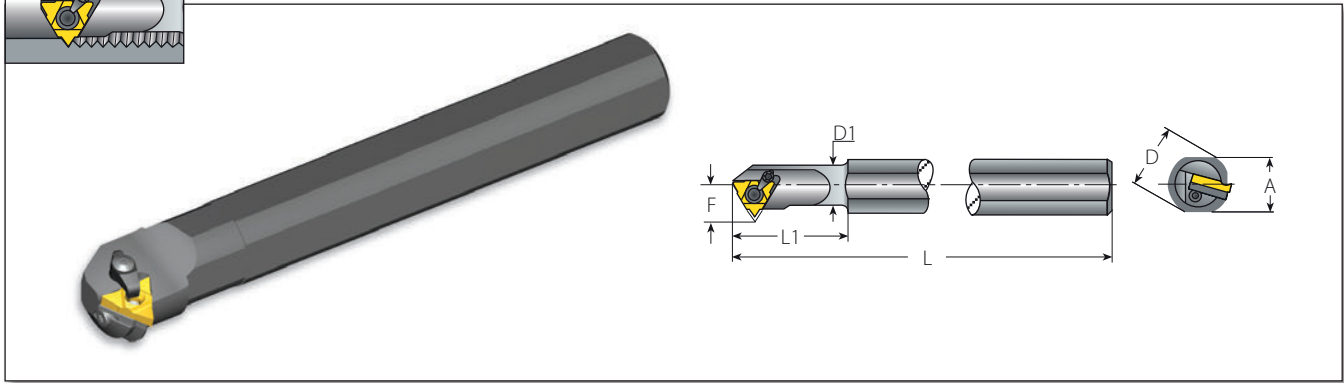

U style with Clamp

(Dual System, Screw or Clamp)

Spare Parts

Insert Size	Ordering Code	EDP No.	Dimensions Inch						Min. Bore Dia.	Spare Parts					
			IC	RH	A	L	L1 (max)	D		D1	F	Inch	Insert Screw	Anvil Screw	Clamp
1/2"U	AVR125-4UC	66408	1.12	10.00	5.00	1.25	1.25	1.01	1.65	SA4T	SY4T	C4	K4T	YI4U	YE4U
	AVR150-4UC	66409	1.34	12.00	6.00	1.50	1.50	1.12	1.90						
5/8"U	AVR150-5UC	66410	1.34	12.00	6.00	1.50	1.50	1.13	1.90	SA5T	SY5T	C5	K5T	YI5U	YE5U
	AVR200-5UC	66411	1.80	14.00	8.00	2.00	2.00	1.37	2.40						
	AVR250-5UC	66412	2.26	16.00	10.00	2.50	2.50	1.61	2.90						

The above toolholders have a 1.5° helix angle. For other helix angles, see page 199.

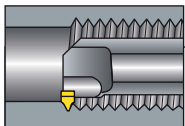

Internal Toolholders

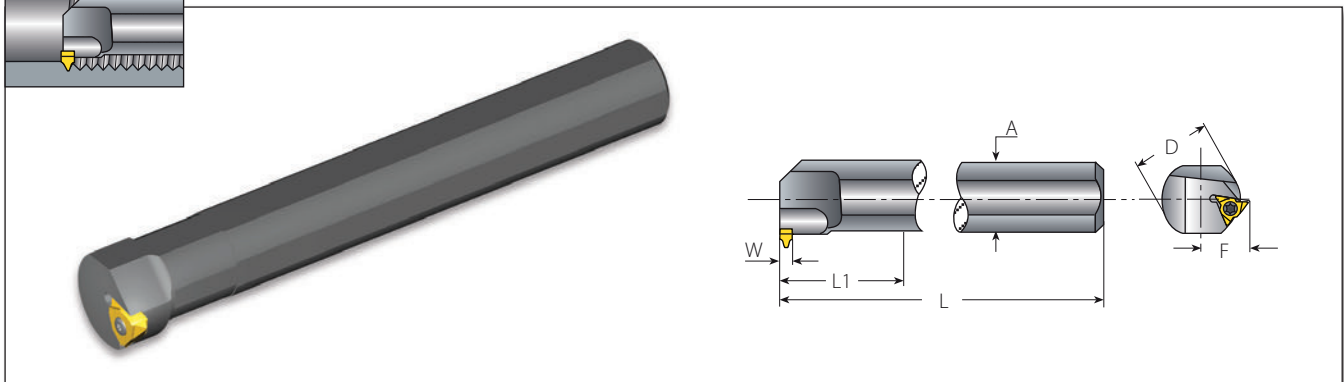

V Style

Spare Parts

Insert Size	Ordering Code	EDP No.	Dimensions Inch						W	Spare Parts	
			IC	RH	A	L	L1 (max)	D		F	Insert Screw
5/8"V	NVR125-5V	67219	1.20	10.00	5.00	1.25	.82	.256	SN6T	K6T	
	NVR150-5V	67220	1.34	12.00	6.00	1.50	1.08				
	NVR200-5V	67222	1.80	14.00	8.00	2.00	1.33				
	NVR250-5V	67223	2.26	16.00	10.00	2.50	1.58				

The above toolholders have a 1.0° helix angle.

Minimum Bore Diameter

	Pitch mm	6.0 ISO	8.0 ISO	10.0 ISO
Holder	Pitch TPI	4 UN	3 UN	2.5 W
NVR125-5V		1.62	1.62	1.62
NVR150-5V		1.98	2.17	2.44
NVR200-5V		2.37	2.37	2.44
NVR250-5V		2.76	2.68	2.68

The above toolholders are for RH inserts. For LH inserts, add LH to the toolholder's ordering code (Example AVR125-4UCLH). Holders with coolant channel available as standard (Example AVRC125-4UC).

Internal Toolholders

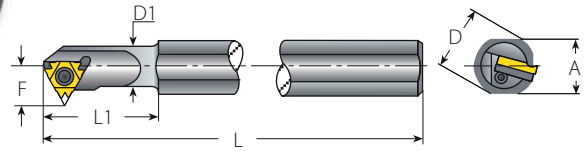
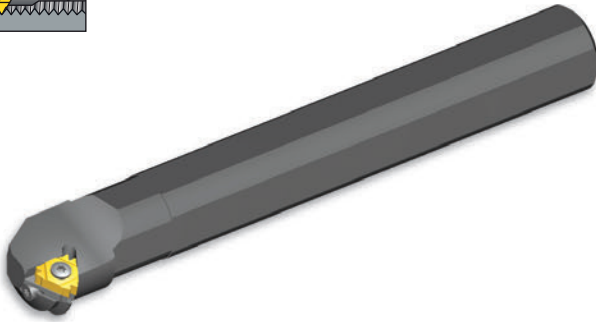
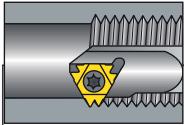

Z+ Style

Insert Size	Ordering Code	EDP No.	Dimensions Inch						Min. Bore Dia.	Spare Parts				
			IC	RH	A	L	L1 (max)	D		D1	F	Inch	Insert Screw	Anvil Screw
1/2"Z	AVR125-4Z	66413	1.12	10.00	5.00	1.25	1.25	1.01	1.65	SA4T	SY4T	K4T	Y14Z	YE4Z
	AVR150-4Z	66414	1.34	12.00	6.00	1.50	1.50	1.12	1.90					
5/8"Z	NVR125-5Z	66415	1.12	10.00	5.00	1.25	1.25	.98	1.65	SN5T	-	K5T	-	-
	AVR150-5Z	66416	1.34	12.00	6.00	1.50	1.50	1.13	1.90					
	AVR200-5Z	66417	1.80	14.00	8.00	2.00	2.00	1.37	2.40	SA5T	SY5T	K5T	Y15Z	YE5Z
	AVR250-5Z	66418	2.26	16.00	10.00	2.50	2.50	1.61	2.90					

Multiplus

Internal Toolholders

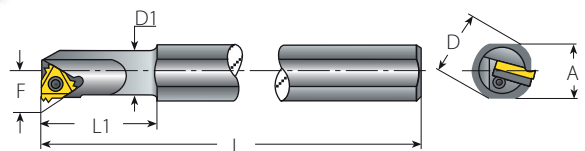
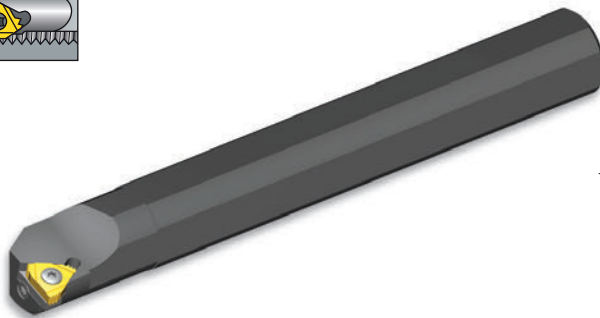
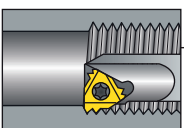

M+ Style

Insert Size	Ordering Code	EDP No.	Dimensions Inch						Min. Bore Dia.	Spare Parts				
			IC	RH	A	L	L1 (max)	D		D1	F	Inch	Insert Screw	Anvil Screw
5/8"M	AVR125-5M	66127	1.12	10.00	5.00	1.25	1.25	.88	1.55	SN5T	SY5T	K5T	Y15M	YE5M
	AVR150-5M	66161	1.34	12.00	6.00	1.50	1.50	1.00	1.80					
	AVR200-5M	66419	1.80	14.00	8.00	2.00	2.00	1.25	2.30	SA5T	SY5T	K5T	Y15M	YE5M
	AVR250-5M	66422	2.26	16.00	10.00	2.50	2.50	1.50	2.80					

Multiplus

The above toolholders have a 1.5° helix angle. For other helix angles, see page 199.
 Holders with coolant channel available as standard (Example AVR125-4Z).

Internal Toolholders

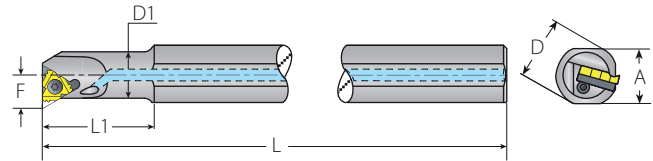
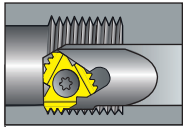

Thread Turning Toolholders

F-Line M+ Style

Spare Parts



Insert Size	Ordering Code	EDP No.	Dimensions Inch						Min. Bore Dia.				
IC	RH		A	L	L1 (max)	D	D1	F	Inch	Insert Screw	Anvil Screw	Torx Key	Anvil RH
1/2" F	AVRC100-4MF	66665	1.12	10.00	2.50	1.25	1.00	.64	1.25	SA4T	SY4T	K6T	Y14M2F
	AVRC100D-4MF	66672	.89	8.00	4.00	1.00	1.00	.64	1.25				
	AVRC125-4MF	66666	1.12	10.00	5.00	1.25	1.25	.76	1.50				
	AVRC150-4MF	66667	1.34	12.00	6.00	1.50	1.50	.90	1.75				
	AVRC200-4MF	66713	1.80	14.00	8.00	2.00	2.00	1.22	2.17				

The above toolholders have a 1.5° helix angle. For other helix angles, see page 199.

Internal Toolholders

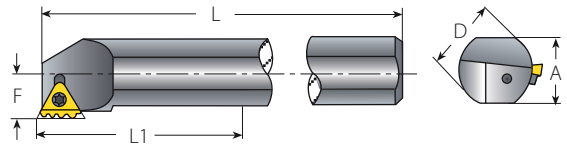
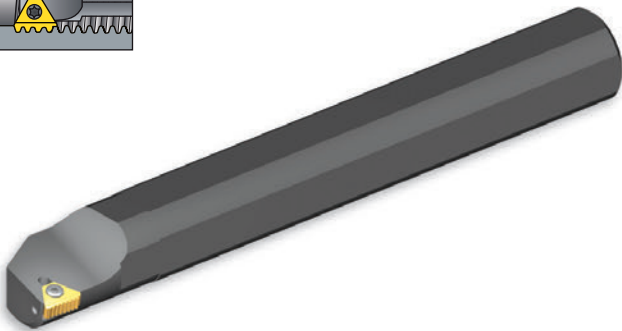
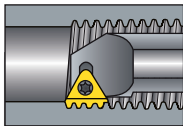

T+ Style

Spare Parts



Insert Size	Ordering Code	EDP No.	Dimensions Inch						Min. Bore Dia.					
IC	RH		A	L	L1 (max)	D	F	Inch	Insert Screw	Anvil Screw	Torx Key	Anvil Torx Key	Anvil RH/LH	
1/2" T	AVR150-4T	66423	1.34	12.00	6.00	1.50	.88	2.40	SA4T	SY4K2	K4T	K2	Y4T	
	AVR200-4T	66424	1.80	14.00	8.00	2.00	1.13	2.75						
	AVR250-4T	66425	2.26	16.00	10.00	2.50	1.38	3.25						

All toolholders have a 0° helix angle.
 Holders with coolant channel available as standard (Example: AVR150-4T).

Internal Toolholders

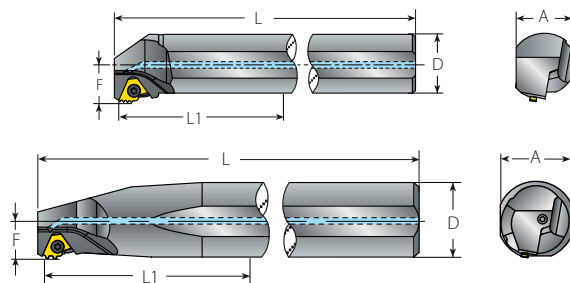
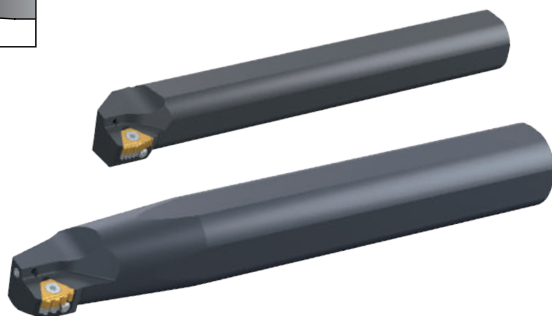
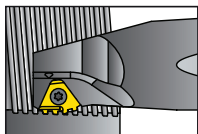

Multiplus

14D Standard

Insert Size		Ordering Code						Dimensions Inch				Min. Bore Dia.				Spare Parts			
IC	RH	A	L	L1 (max)	D	F	Inch	Insert Screw	Anvil Screw & Washer	Torx Key	Anvil Key								
14D	AVRC150-14D	1.34	12.00	6.00	1.50	1.03	2.15	SA5T	M4x6(14D)	K5T	KT15								
	AVRC200-14D	1.80	12.00	8.00	2.00	1.00	2.15												

Internal Toolholders

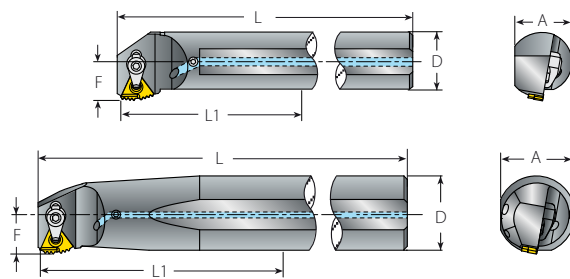
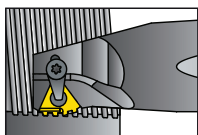

Multiplus

14D Standard with Clamp

Insert Size		Ordering Code						Dimensions Inch					Min. Bore Dia.					Spare Parts				
IC	RH	A	L	L1 (max)	D	F	Inch	Insert Screw	Anvil Screw & Washer	Clamp	Torx Key	Anvil Key										
14D	AVRC150-14DC	1.34	12.00	6.00	1.50	1.03	2.15	SA5T	M4x6(14D)	C5	K5T	KT15										
	AVRC200-14DC	1.80	12.00	8.00	2.00	1.00	2.15															

14D holders are supplied without anvils. For specific applications, please use the anvils indicated in the table on page 200.

Internal Toolholders

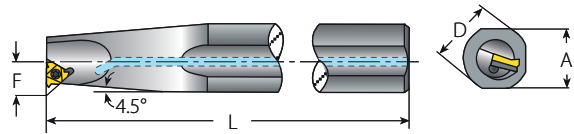
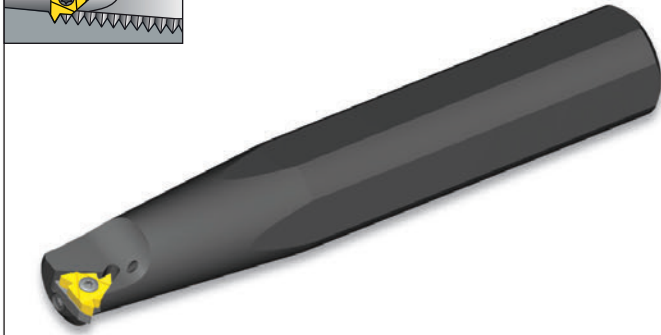
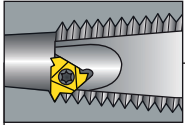

Thread Turning Toolholders

Oil & Gas

Spare Parts

Insert Size	Ordering Code	EDP No.	Thread Form	Connection No. or Size	Dimensions Inch				Helix Angle Deg.	Spare Parts								
					A	L	D	F		Insert Screw	Anvil Screw	Torx Key	Anvil RH					
	RH																	
3/8"	AVRC100-3 APIRD	66529	APIRD 8 APIRD 10	2.375"-20" 1.315"-3.5"	1.12	10.00	1.00	.65	1									
	AVRC125-3 APIRD	66530	APIRD 8 APIRD 10	2.375"-20" 1.66"-3.5"	1.12	10.00	1.25	.77	1	SA3T	SY3T	K3T	YEI3-APIRD					
	AVRC150-3 APIRD	66531	APIRD 8 APIRD 10	2.375"-20" 1.9"-3.5"	1.34	12.00	1.50	.90	0									
1/2"	AVRC150-4 5BUT/API	66534	5BUT, V0.038R, V0.050, V0.040, V0.055	4 1/2"-20" NC10-NC77 all sizes	1.34	12.00	1.50	.98	0	SA4T	SY4T	K4T	YEI4-API-1P YEI4-5BUT					
	AVR200-5OIL	66426	V0.038R	NC23-NC38	1.80	12.00	2.00	.90	1.5									
5/8"	AVRC200-5OIL	66122	V0.038R	NC23-NC38						SA5T	SY5T	K5T	YI5OIL					
	AVR300-5OIL	66188	V0.050R	NC40-NC77	2.68	16.00	3.00	1.50	1.5									
	AVRC300-5OIL	66125	V0.050R	NC40-NC77														

Toolholders ordered with an internal coolant channel have an internal BSP 1/2" thread for connection to the flexible coolant pipe.

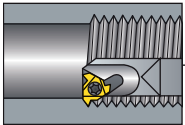

Internal Toolholders

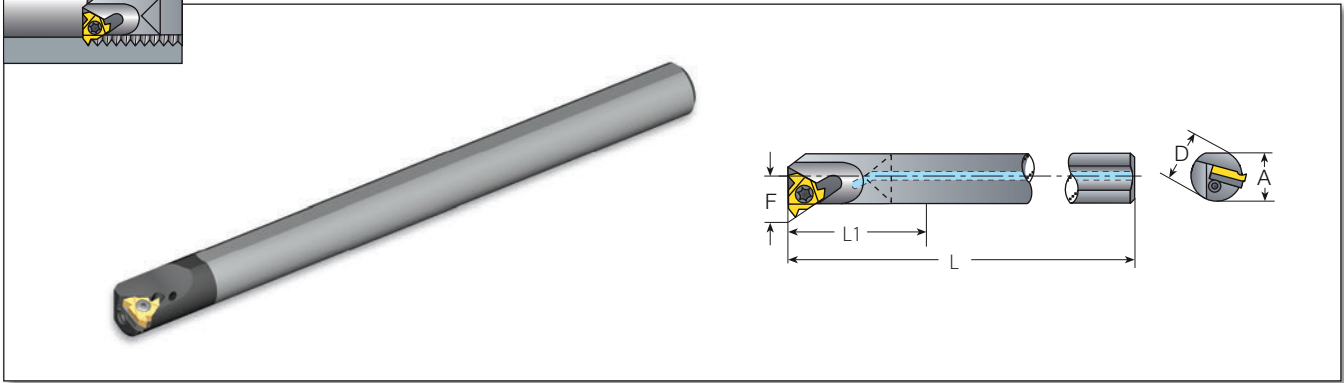

Standard with Carbide Shank

Spare Parts

Insert Size	Ordering Code	EDP No.	Dimensions Inch					Min. Bore Dia.	Spare Parts				
			IC	RH	D	A	F		L	L1 (Max)	Inch	Insert Screw	Anvil Screw
1/4"	CNVRC0375-2	66196	.37	.35	.28	6.00	2.22	.50	SN2T	-	K2T	-	-
	CNVRC050-2	66197	.50	.48	.35	7.00	3.00	.60	-	-	-	-	
3/8"	CNVRC050-3	66199	.50	.48	.40	7.00	3.00	.67	SN3T	-	K3T	-	-
	CNVRC0625-3	66200	.62	.60	.45	8.00	3.72	.80	-	-	-	-	
	CAVRC075-3	66194	.75	.73	.51	10.00	4.50	.90	SA3T	SY3T	K3T	Y13	YE3
1/2"	CNVRC075-4	66202	.75	.73	.59	10.00	4.50	1.00	SN4T	-	K4T	-	-

Toolholders with prefix "CN" cannot be used with an anvil. The above toolholders have coolant channel as standard.

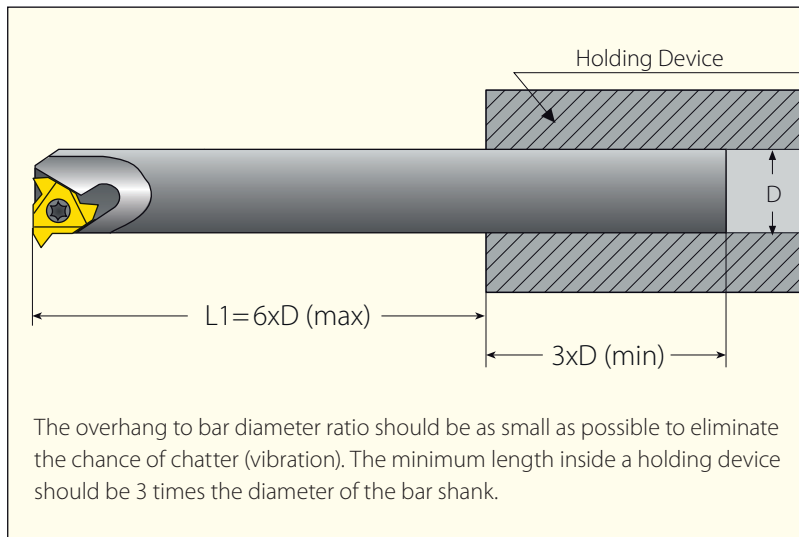

The above toolholders have 1.5° helix angle. For other helix angles see page 199.
 The above toolholders are for RH inserts. For LH inserts, add LH to the toolholder's ordering code (Example CNVRC0375-2LH).

Internal Toolholders

Mini-V

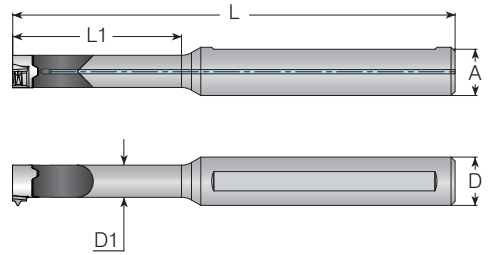
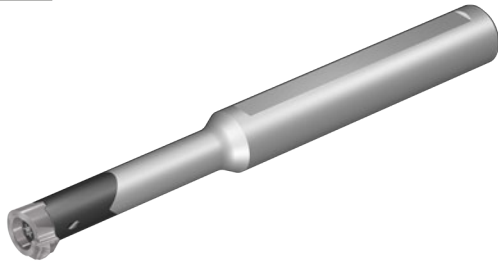
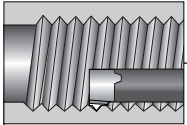

Carbide Shank with Alloy Steel Head

Spare Parts

Insert Style	Ordering Code		Dimensions Inch					Spare Parts		
	Sleeve	RH	A	L	L1	D	D1	Screw	Size	Torx Key
V08	-	CV08-05000827	.433	3.150	.827	.500	.236	SNV08	M2.6x.45x8	K2T
	-	CV08-05001180		3.540	1.181					
V11	-	CV11-05001142	.433	3.150	1.142	.500	.315	SNV11	M3.5x.6x10	K3T
	-	CV11-05001654		3.540	1.654					
V16	-	CV16-05001575	.591	5.120	1.575	.625	.433	SNV16	M5x.8x12	K4T
	-	CV16-06251575		5.120	1.575					

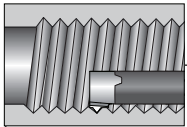

Internal Toolholders

Mini-V

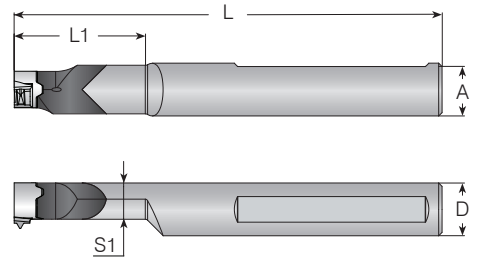
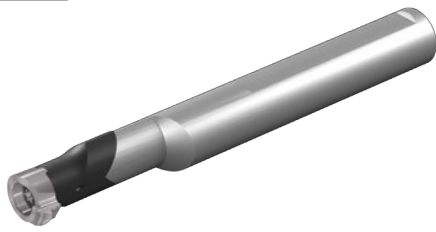

Thread Turning Toolholders

Reinforced Carbide Shank

Spare Parts

Insert Style		Ordering Code		Dimensions Inch					Spare Parts		
Sleeve	RH	A	L	L1	D	S1	Screw	Size	Key		
V14	-	CV14-05001339	.433	3.940	1.339	.500	.379	SNV14	M4x0.7x12	KT15	

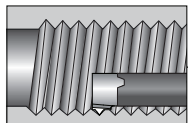

Internal Toolholders

Mini-V

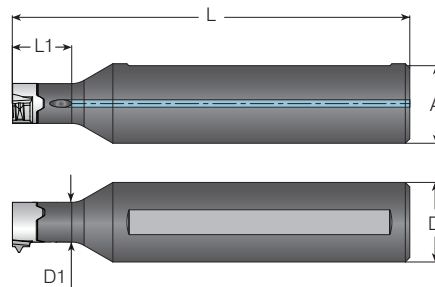

Alloy Steel Shank (Metric)

Spare Parts

Insert Style		Ordering Code	Dimensions mm					Spare Parts		
Sleeve	RH		A	L	L1	D (mm)	D1	Screw	Size	Torx Key
V08	-	V08-1612	15.6	80	12			SNV08	M2.6x0.45x8	K2T
V11	-	V11-1612	15.6	80	12	16	8	SNV11	M3.5x0.6x10	K3T
V16	-	V16-1622	15.0	100	22		11	SNV16	M5.0x0.8x12	K4T

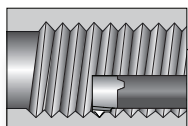

Internal Toolholders

Mini-V

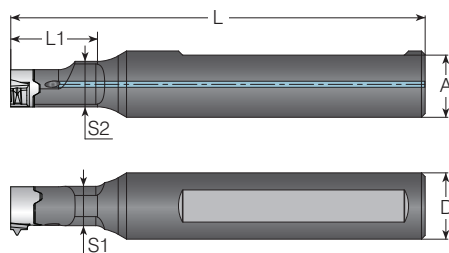

Alloy Steel Shank (Metric)

Spare Parts

Insert Style		Ordering Code	Dimensions mm						Spare Parts		
Sleeve	RH		A	L	L1	D (mm)	S1	S2	Screw	Size	Torx Key
V14	-	V14-1620	15.0	100	20	16	9.5	11	SNV14	M4x0.7x12	KT15

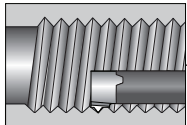

Internal Toolholders

Mini-V

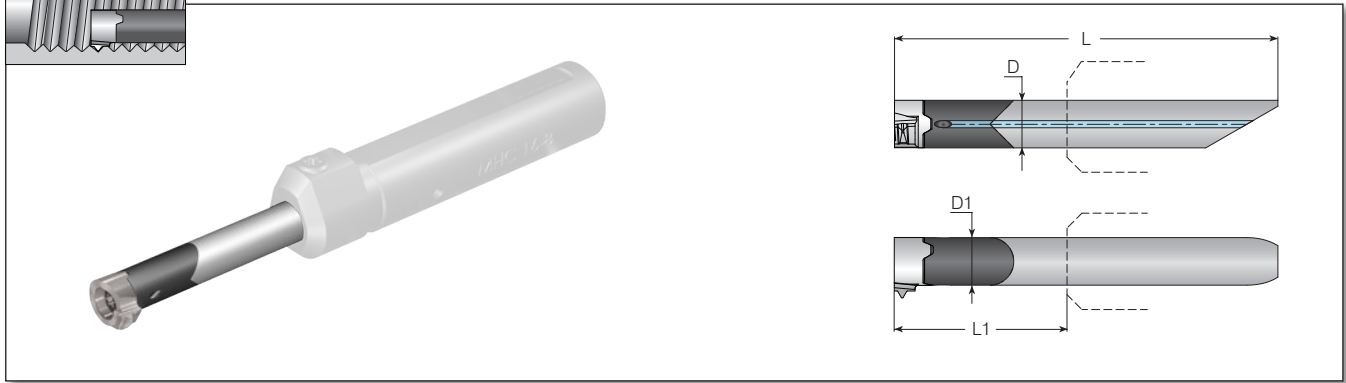

Holder for Sleeve Clamping

Spare Parts

Insert Style	Ordering Code	Dimensions Inch					Ordering Code	Spare Parts		
	RH	A	L	L1 (max)	D (mm)	D1	Sleeve	Screw	Size	Torx Key
V08	CV08-0621	-	1.772	.827	6	.236	MHC...-6	SNV08	M2.6x0.45x8	K2T
V11	CV11-0829	-	2.539	1.142	8	.315	MHC...-8	SNV11	M3.5x0.6x10	K3T

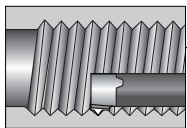

Internal Toolholders

Mini-V

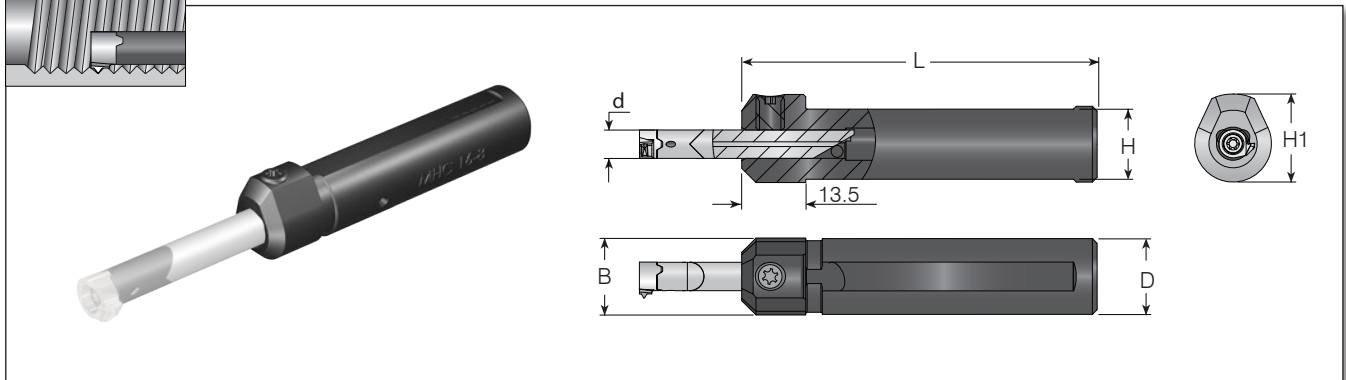

Sleeves

Spare Parts

Ordering Code		Dimensions Inch				Spare Parts	
d (mm)	Sleeve	D=B	H1	H	L	Screw	Torx Key
6	MHC 0500-6	0.500	0.644	0.394	2.756	SL7DT15	KT15
	MHC 0625-6	0.625	0.732	0.551	2.953		
	MHC 0750-6	0.750	0.866	0.709	3.543		
8	MHC 0625-8	0.625	0.732	0.583	1.667		
	MHC 0750-8	0.750	0.769	0.697	1.667		

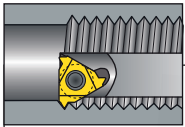

Internal Toolholders Standard

MINIPRO

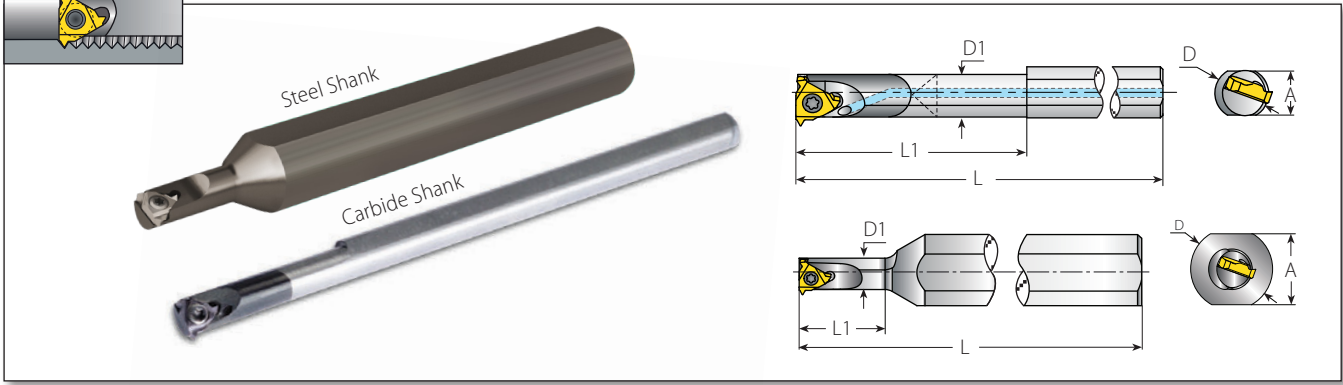

Mini-3 Standard

Insert Size	Ordering Code	EDP No.	Dimensions Inch					Anti-Vibration System	Spare Parts	
			A	L	L1	D	D1		Insert Screw	Torx Key
4.0	SNVR0205-4.0K	42267	.46	4.00	.47	.50	.20	No	SN4MT	K6MT
	CNVRC0205-4.0K	66347	.20	4.00	1.02	.25	.20	Carbide Shank		

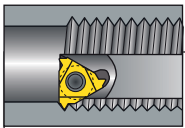

Internal Toolholders Standard

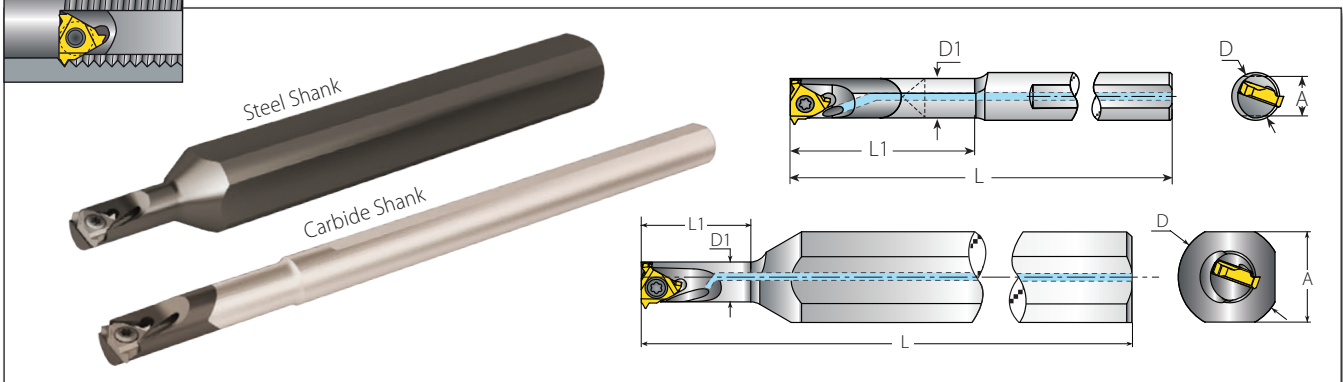

Mini-3 Standard

Insert Size	Ordering Code	EDP No.	Dimensions Inch					Anti-Vibration System	Spare Parts	
			A	L	L1	D	D1		Insert Screw	Torx Key
5.0	NVRC260-5.0K	66258	.59	5.00	.70	.62	.26	No	SN5MT	K6MT
	CNVRC260-5.0K	66262	.28	5.00	1.22	.31	.26	Carbide Shank		

The above toolholders have 2.5° helix angle.
 The above toolholders are for RH inserts. For LH inserts, add LH to the toolholder's ordering code (Example: CNVRC205-4.0KLH).

Internal Toolholders U Style

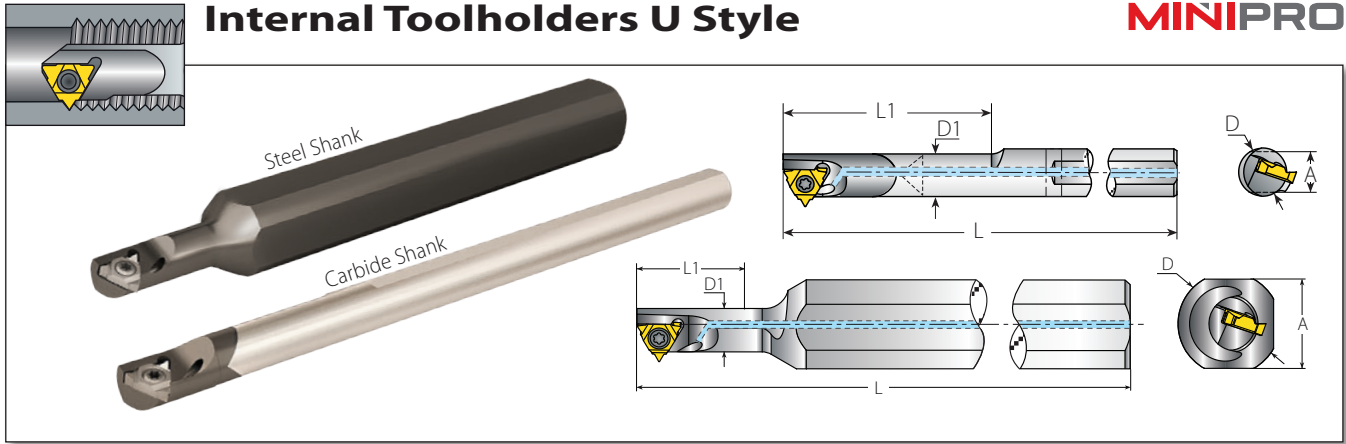

Mini-3 U Style

Insert Size	Ordering Code	EDP No.	Dimensions Inch					Anti-Vibration System	Spare Parts	
			A	L	L1	D	D1		Insert Screw	Torx Key
5.0U	NVRC290-5.0KU	66247	.59	5.00	.83	.62	.29	No	SN5MT	K6MT
	CNVRC290-5.0KU	66249	.28	5.00	1.38	.31	.29	Carbide Shank		

Internal Toolholders

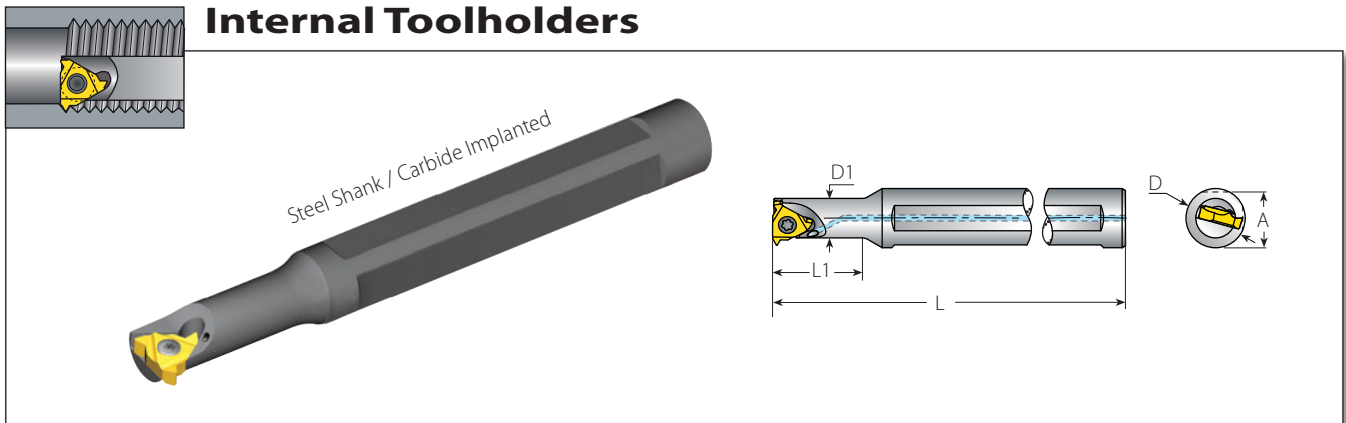

Mini-3 Standard

Insert Size	Ordering Code	EDP No.	Dimensions Inch					Anti-Vibration System	Spare Parts	
			A	L	L1	D	D1		Insert Screw	Torx Key
6.0	SNVRC0375U-6.0K	66692	.36	3.23	.63	.375	.31	No	SN6MTN	KIP6
	BNVRC0375S-6.0K	66693	.36	3.50	.87			Carbide Implanted		
	BNVRC0375M-6.0K	66694	.36	3.86	1.22			Carbide Implanted		
	BNVRC0375L-6.0K	66695	.36	4.33	1.69			Carbide Implanted		
6.0	SNVRC050U-6.0K	66696	.49	3.23	.63	.50	.31	No	SN6MTN	KIP6
	BNVRC050S-6.0K	66697	.49	3.50	.87			Carbide Implanted		
	BNVRC050M-6.0K	66698	.49	3.86	1.22			Carbide Implanted		
	BNVRC050L-6.0K	66699	.49	4.33	1.69			Carbide Implanted		

The above toolholders have 2.5° helix angle.
 The above toolholders are for RH inserts. For LH inserts, add LH to the toolholder's ordering code (Example: NVRC290-5.0KULH).

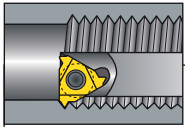

Internal Toolholders

MINIPRO

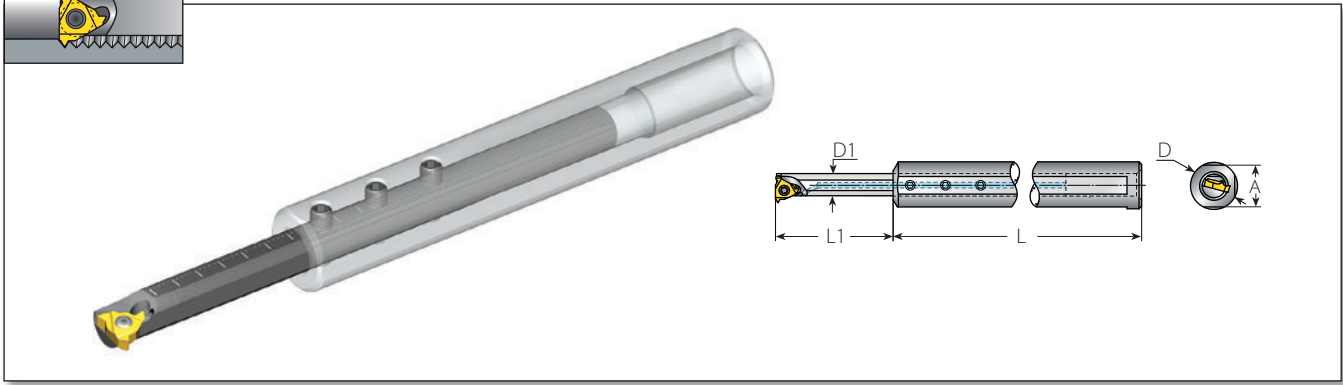

Mini-3 Adjustable

Spare Parts

Insert Size		EDP No.	Ordering Code	EDP No.	Dimensions Inch					Spare Parts			
IC mm	Sleeve		Holder RH		A	L	L1	D	D1	Insert Screw	Torx Key for Insert Screw	Holder Screw x3	Key for Holder Screw
6.0	SVC0625-8.0	66700	BNVRC8.0T-6.0K	66701	.584	4	.315-2.2	.625	.315	SN6MTN	KIP6	S4.0	K2.0

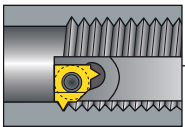

Internal Toolholders

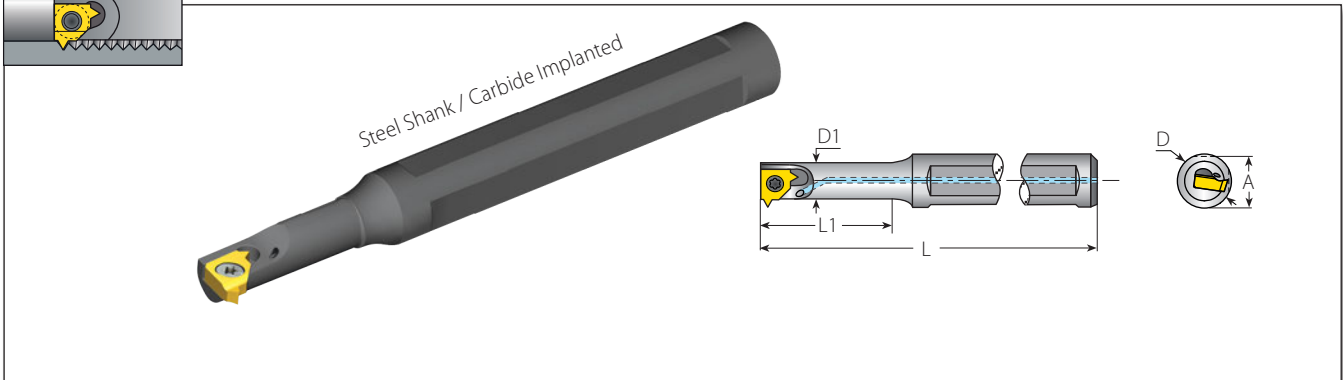

Mini-L

Spare Parts

Insert Size	Ordering Code	EDP No.	Dimensions Inch					Anti-Vibration System	Spare Parts	
IC mm	RH		A	L	L1	D	D1		Insert Screw	Torx Key
5.0L	SNVRC0375U-5LK	66702	.36	3.19	.63	.375	.24	No	SN5LSTR	K7MT
	BNVRC0375S-5LK	66703	.36	3.43	.87			Carbide Implanted		
	BNVRC0375M-5LK	66704	.36	3.82	1.22			Carbide Implanted		
	BNVRC0375L-5LK	66705	.36	4.29	1.69			Carbide Implanted		
5.0L	SNVRC050U-5LK	66706	.49	3.19	.63	.50	.24	No	SN5LSTR	K7MT
	BNVRC050S-5LK	66707	.49	3.43	.87			Carbide Implanted		
	BNVRC050M-5LK	66708	.49	3.82	1.22			Carbide Implanted		
	BNVRC050L-5LK	66709	.49	4.29	1.69			Carbide Implanted		

The above toolholders have 2.5° helix angle.
 The above toolholders are for RH inserts. For LH inserts, add LH to the toolholder's ordering code (Example: SNVRC375U-5LK**LH**).

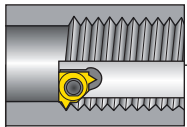

Internal Toolholders

MINIPRO

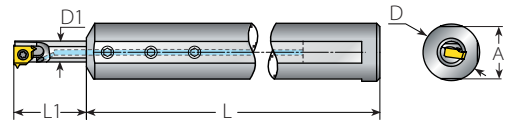
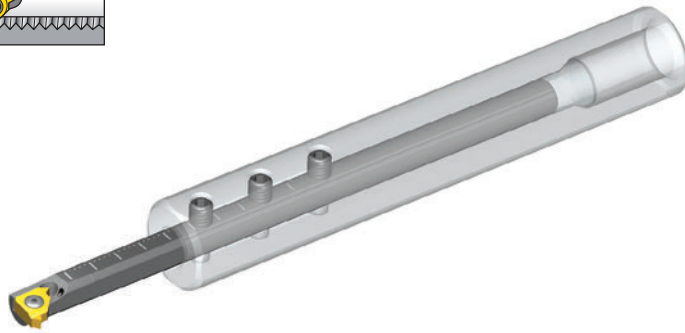

Mini-L-Adjustable

Spare Parts

Insert Size	EDP No.	Ordering Code	EDP No.	Dimensions Inch					Spare Parts				
IC mm	Sleeve	Holder RH		A	L	L1	D	D1	Insert Screw	Torx Key for Insert Screw	Holder Screw x 3	Key for Holder Screw	
5.0L	SVC0625-6.2	66710	BNVRC6.2T-5LK	66711	.58	4.00	.315-1.73	.625	.24	SN5LSTR	K7MT	S4.0	K2.0

The above toolholders are for RH inserts. For LH inserts, add LH to the toolholder's ordering code (Example: BNVRC6.2T-5LK**LH**).

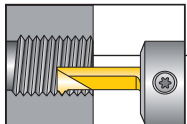

Internal Toolholders

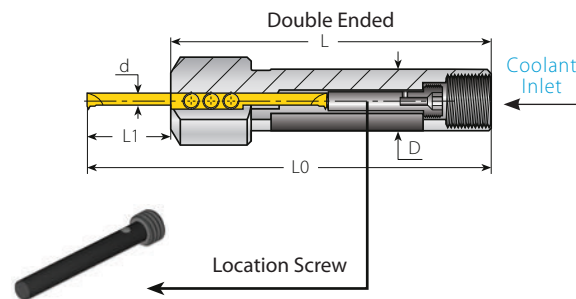
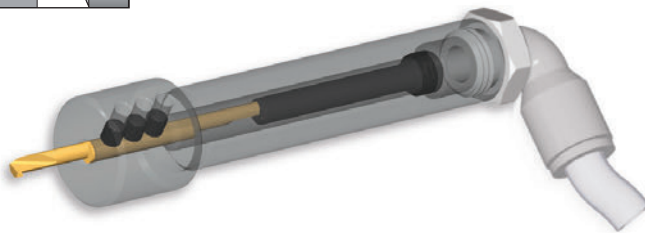

Micro - Double Ended

Spare Parts

Micro Insert Dia.	Shank Dia.	Ordering Code	EDP No.	Dimensions Inch			Location Screw (Every toolholder package contains the full range of location screws needed)		Clamping Screw x 3		
d mm	D			L	L1	L0	Screw	M	Key	Screw	Key
3	.50	SMC050-3.0	41075	3.15	.35- Short	3.50	4GISM8X28	1.10	K4.0	M4X0.7X4.0	K2.0
	.625	SMC0625-3.0	40210		.63- Medium	3.78	4GISM8X21	.83			
	.75	SMC075-3.0	41080	3.74	.35- Short	4.09	4GISM8X49	1.93			
4	.50	SMC050-4.0	41092	3.15	.63- Medium	3.78	4GISM8X21	.83			
					.83- Long	3.98	4GISM8X16	.63			
	.625	SMC0625-4.0	40212	3.74	.35- Short	4.09	4GISM8X49	1.93			
					.63- Medium	4.37	4GISM8X42	1.65			
	.75	SMC075-4.0	41081	3.74	.83- Long	4.57	4GISM8X37	1.46			
					.50	SMC050-6.0	41517	3.15	.35- Short	3.50	4GISM8X28
.63- Medium	3.78	4GISM8X21	.83								
.83- Long	3.98	4GISM8X16	.63								
6	.625	SMC0625-6.0	40214	3.74	.35- Short	4.09	4GISM8X49	1.93			
					.63- Medium	4.37	4GISM8X42	1.65			
	.75	SMC075-6.0	41082	3.74	.83- Long	4.57	4GISM8X37	1.46			

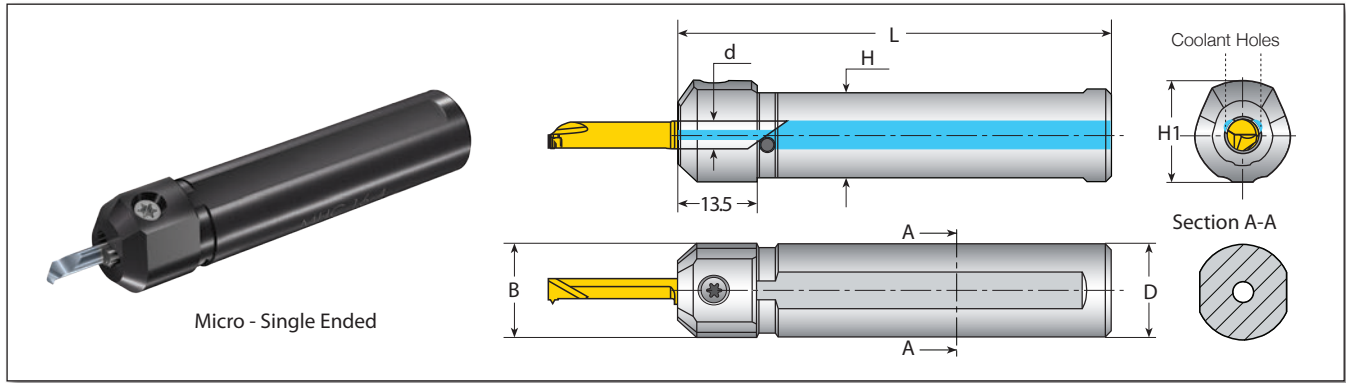

Micro - Single Ended

Round Shanks 2 Flats (Inch)

Micro Insert Dia.	Ordering Code	Dimensions Inch					Spare Parts	
d mm		D	B	H1	H	L		
4.0	MHC0500-4	.500	.500	.644	.394	2.76	SL7DT15 or SL7DBT15IP*	KT15 or F15IP*
	MHC0625-4	.625	.638	.732	.551	2.95		
	MHC0750-4	.750	.827	.827	.709	3.54		
5.0	MHC0500-5	.500	.500	.644	.394	2.76		
	MHC0625-5	.625	.638	.732	.551	2.95		
	MHC0750-5	.750	.827	.827	.709	3.54		
6.0	MHC0500-6	.500	.500	.644	.394	2.76		
	MHC0625-6	.625	.638	.732	.551	2.95		
	MHC0750-6	.750	.827	.827	.709	3.54		
7.0	MHC0625-7	.625	.638	.732	.551	2.95		
	MHC0750-7	.750	.827	.827	.709	3.54		

Round Shanks 2 Flats (Metric)

Micro Insert Dia.	Ordering Code	Dimensions mm				Spare Parts	
d mm		D=B	H1	H	L		
4.0	MHC10-4	10	14	8.8	65	SL7DT15 or SL7DBT15IP*	KT15 or F15IP*
	MHC12-4	12	16	10.8	70		
	MHC16-4	16	17.6	14.8	75		
	MHC20-4	20	22	18.8	84		
5.0	MHC10-5	10	14	8.8	65		
	MHC12-5	12	16	10.8	70		
	MHC16-5	16	18.6	14.8	75		
6.0	MHC20-5	20	22	18.8	84		
	MHC12-6	12	16	10.8	70		
	MHC16-6	16	18.6	14.8	75		
7.0	MHC20-6	20	22	18.8	84		
	MHC16-7	16	18.6	14.8	75		
	MHC20-7	20	22	18.8	84		

*Torx+ Screw and key are now available for improved clamping

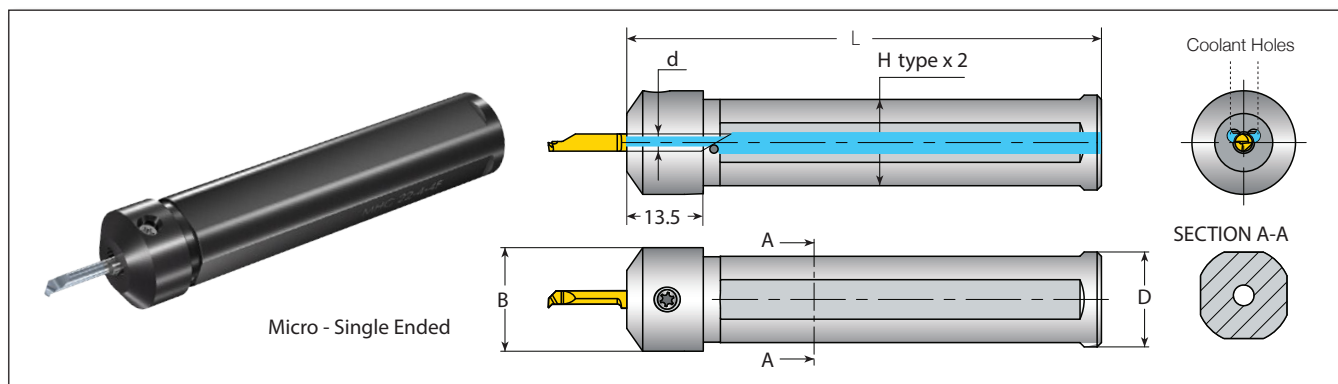

Micro - Single Ended

Round Shank - 4 Flats (Inch)

Micro Insert Dia.	Ordering Code	Dimensions Inch				Spare Parts	
d (mm)		D	B	H	L		
4.0	MHC0875-4-4F	.875	.925	.82	3.29	SL7DT15 or SL7DBT15IP*	KT15 or F15IP*
	MHC1000-4-4F	1.000	1.063	.90	4.33		
5.0	MHC0875-5-4F	.875	.925	.82	3.29		
	MHC1000-5-4F	1.000	1.063	.90	4.33		
6.0	MHC1000-6-4F	1.000	1.063	.90	4.33		

Round Shank - 4 Flats (Metric)

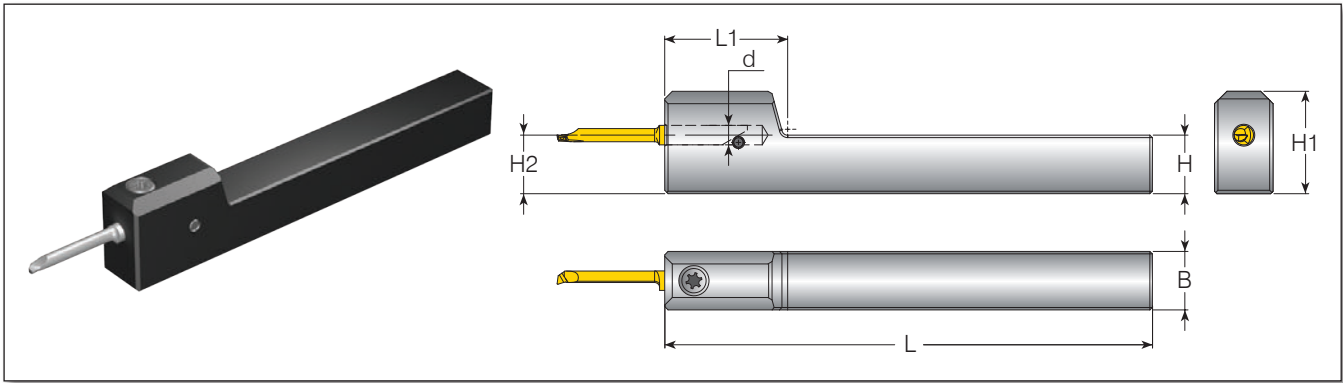

Micro Insert Dia.	Ordering Code	Dimensions mm				Spare Parts	
d mm		D	B	H	L		
4.0	MHC20-4-4F	20.0	22.0	18.8	83.5	SL7DT15 or SL7DBT15IP*	KT15 or F15IP*
	MHC22-4-4F	22.0	24.0	20.0			
	MHC23-4-4F	23.0	25.0	21.0	110		
	MHC25-4-4F	25.0	27.0	23.0			
	MHC28-4-4F	28.0	30.0	26.0			
5.0	MHC20-5-4F	20.0	22.0	18.8	83.5		
	MHC22-5-4F	22.0	24.0	20.0	110		
	MHC23-5-4F	23.0	25.0	21.0			
	MHC25-5-4F	25.0	27.0	23.0			
	MHC28-5-4F	28.0	30.0	26.0			
6.0	MHC20-6-4F	20.0	22.0	18.8	83.5		
	MHC22-6-4F	22.0	24.0	20.0			
	MHC23-6-4F	23.0	25.0	21.0	110		
	MHC25-6-4F	25.0	27.0	23.0			
	MHC28-6-4F	28.0	30.0	26.0			
7.0	MHC22-7-4F	22.0	24.0	20.0	110		
	MHC23-7-4F	23.0	25.0	21.0			
	MHC25-7-4F	25.0	27.0	23.0			
	MHC28-7-4F	28.0	30.0	26.0			

*Torx+ Screw and key are now available for improved clamping





Microscope Holder with Square Shank (Inch)

Spare Parts

Micro Insert Dia.	Ordering Code	Dimensions Inch					
d (mm)		H=H2=B	H1	L	L1	Clamping Screw	Torx Key
4.0	MHS0500-4	.500	.827	4.00	.984	SL7DT15 or SL7DBT15IP*	KT15 or F15IP*
	MHS0625-4	.625	.984	5.00	.984		
5.0	MHS0500-5	.500	.846	4.00	1.063		
	MHS0625-5	.625	1.004	5.00	1.377		
6.0	MHS0500-6	.500	.866	4.00	1.063		
	MHS0625-6	.625	1.024	5.00	1.377		
7.0	MHS0625-7	.625	1.043	5.00	1.377		

Microscope Holder with Square Shank (Metric)

Spare Parts

Micro Insert Dia.	Ordering Code	Dimensions mm					
d mm		H=H2=B	H1	L	L1	Clamping Screw	Torx Key
4.0	MHS1010-4	10.0	19.0	100.0	25.0	SL7DT15 or SL7DBT15IP*	KT15 or F15IP*
5.0	MHS1010-5	10.0	19.5	100.0	25.0		
4.0	MHS1212-4	12.0	21.0	100.0	25.0		
5.0	MHS1212-5	12.0	21.5	100.0	27.0		
6.0	MHS1212-6	12.0	22.0	100.0	27.0		

*Torx+ Screw and key are now available for improved clamping

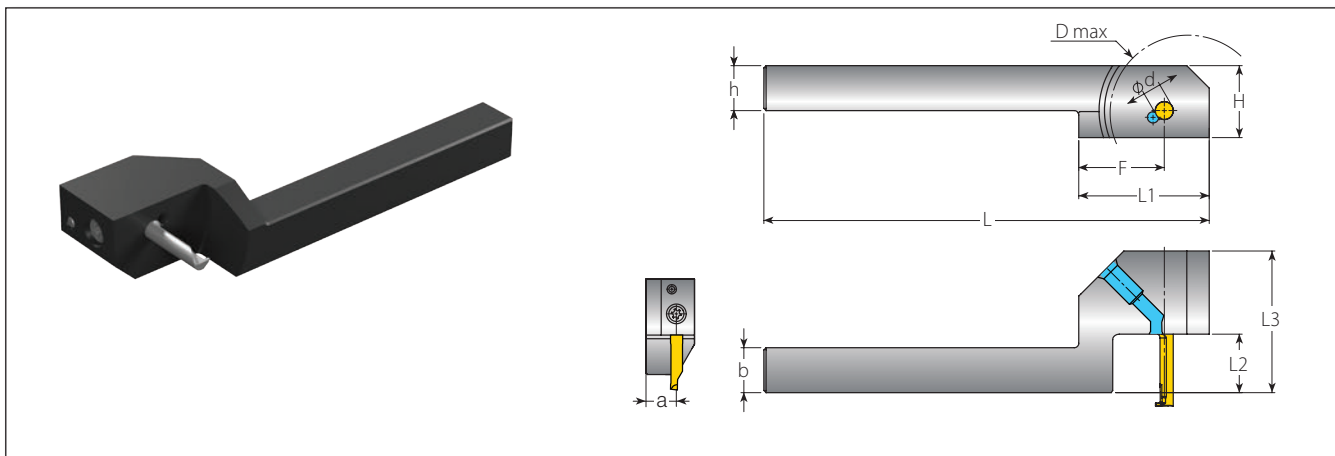

Microscope Holder with Drop Head (Inch)

Micro Insert Dia.	Ordering Code	Dimensions Inch								Spare Parts							
d mm	a=b=h	L3	H	L	L1	F	D max	L2	Clamping Screw	Torx Key							
4.0	MHD0375-4L0700	.375	1.437	.630	3.898	1.142	.748	1.024	.709	SL7DT15 or SL7DBT15IP*	KT15 or F15IP*						
5.0	MHD0375-5L0800		1.890						.906								
6.0	MHD0375-6L0800		2.087						.906								
4.0	MHD0500-4L0700	.500	1.437	.748					3.898			1.142	.748	1.024	.709	SL7DT15 or SL7DBT15IP*	KT15 or F15IP*
5.0	MHD0500-5L0800		1.890												.906		
6.0	MHD0500-6L1000		2.087												1.102		

Microscope Holder with Drop Head (Metric)

Micro Insert Dia.	Ordering Code	Dimensions mm								Spare Parts							
d mm	a=b=h	L3	H	L	L1	F	D max	L2	Clamping Screw	Torx Key							
4.0	MHD1010-4L0500	10.0	31.5	16.0	99.0	29.0	19.0	26.0	13.0	SL7DT15 or SL7DBT15IP*	KT15 or F15IP*						
5.0	MHD1010-5L0800		48.0						23.0								
6.0	MHD1010-6L1000		53.0						28.0								
4.0	MHD1212-4L0700	12.0	36.5	18.0					99.0			29.0	19.0	26.0	18.0	SL7DT15 or SL7DBT15IP*	KT15 or F15IP*
5.0	MHD1212-5L0800		48.0												23.0		
6.0	MHD1212-6L1000		53.0												28.0		

*Torx+ Screw and key are now available for improved clamping



Thread Turning Technical Data

Thread Terminology

External Thread

A thread on the external surface of a cylinder screw or cone.

Depth of Thread

The distance between crest and root measured normal to the axis.

Pitch

The distance between two corresponding points on adjacent thread forms is measured parallel to the axis. This distance can be defined in either millimeters or by TPI (threads per inch).

Nominal Diameter

The diameter from which the diameter limits are derived by the application of deviation allowances and tolerances.

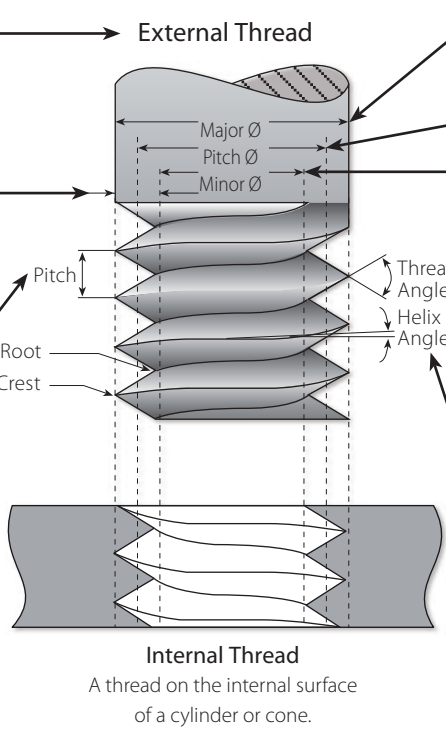

Major Diameter

The largest diameter of a screw thread.

Pitch Diameter

On a straight thread, the diameter of an imaginary cylinder, the surface of which cuts the thread forms where the width of the thread and groove are equal.

Minor Diameter

The smallest diameter of a screw thread.

Helix Angle

For a straight thread, where the lead of the thread and the pitch diameter circle circumference form a right angled triangle, the helix angle is the angle opposite the lead.

Straight Thread

A thread formed on a cylinder.

Taper Thread

A thread formed on a cone.

Left-hand thread

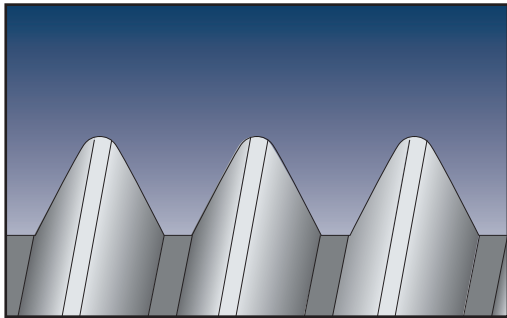

A thread which, when viewed axially, winds in a counterclockwise and receding direction. All left-hand threads are designated LH.

Right-hand thread

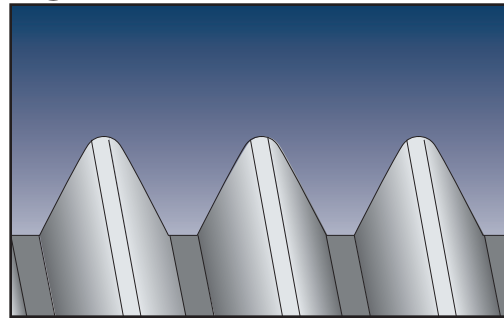

A thread which, when viewed axially, winds in a clockwise and receding direction. Threads are always right-hand unless otherwise specified.

The Helix Angle β

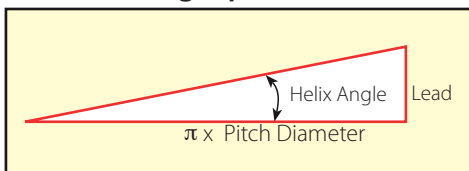

Lead

The distance a threaded part moves axially, with respect to a fixed mating part, in one complete revolution.

The lead is equal to the pitch multiplied by the number of thread starts.

Machining a Multi-Start Thread

A thread in which the lead is an integral multiple, greater than one, of the pitch.
 A multi-start thread permits a more rapid advance without a coarser (larger) thread form.

First Start Machined

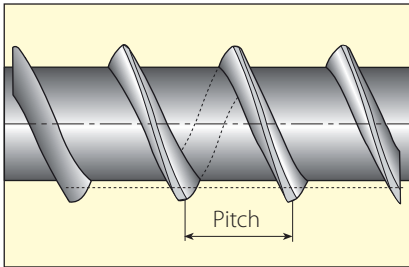

Second Start Machined

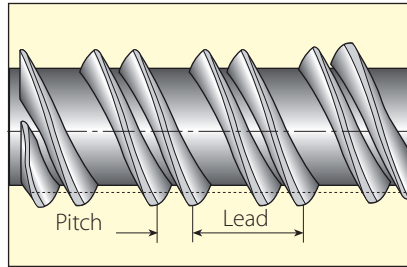

Third Start Machined
(Final, 3 Starts Thread)

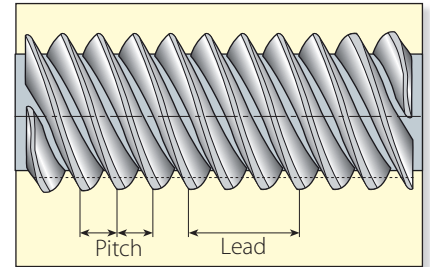

Lead = 3 x Pitch

Insert Profile Styles

Partial Profile

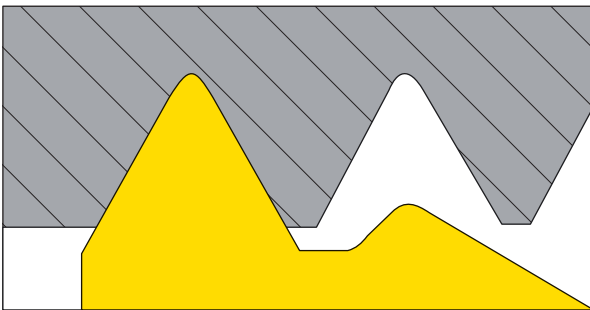

The V partial profile insert cuts without topping the outer diameter of the thread. The same insert can be used for a range of different thread pitches which have a common thread angle.

Full Profile

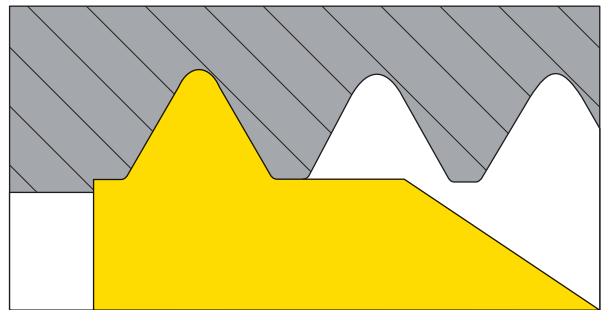

The full profile insert will form a complete thread profile including the crest. For every thread pitch and standard, a separate insert is required.

Full Profile for Fine Pitches

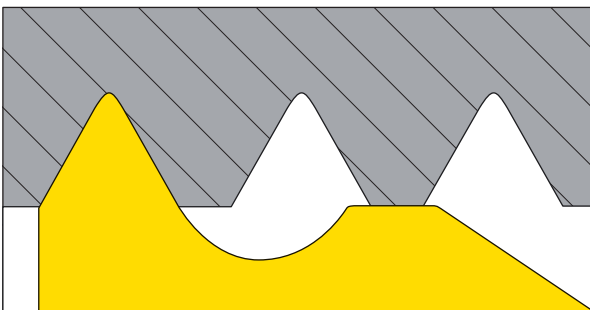

The full profile for Fine Pitches will form a complete thread. The topping of the outer diameter is generated by the second tooth.

Semi Full

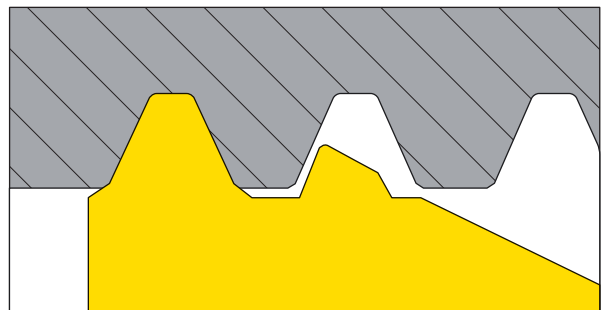

The Semi full profile insert will form a complete thread including crest radius but without topping the outer diameter. Mainly used for trapezoidal profiles.

Thread Turning Methods for Symmetrical Inserts

Thread	Inserts & Toolholder	Rotation	Feed Direction	Helix Method	Drawing No.
Right Hand External	EX RH	Counterclockwise	Towards chuck	Regular	1
	EX LH	Clockwise	From chuck	Reversed	2
Right Hand Internal	IN RH	Counterclockwise	Towards chuck	Regular	3
	IN LH	Clockwise	From chuck	Reversed	4
Left Hand External	EX LH	Clockwise	Towards chuck	Regular	5
	EX RH	Counterclockwise	From chuck	Reversed	6
Left Hand Internal	IN LH	Clockwise	Towards chuck	Regular	7
	IN RH	Counterclockwise	From chuck	Reversed	8

External RH Thread

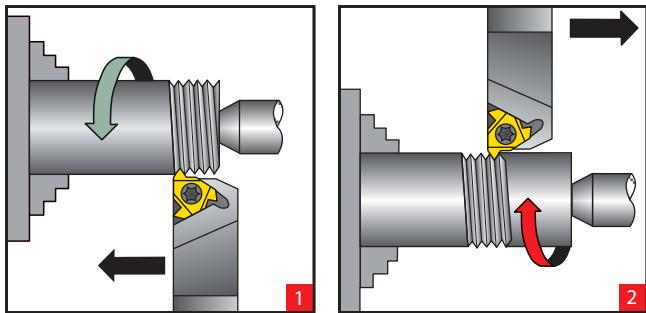

External LH Thread

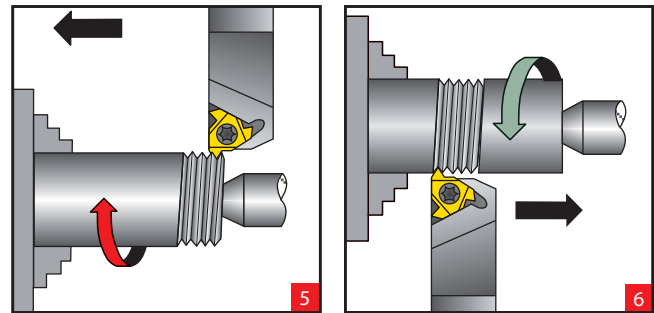

Internal RH Thread

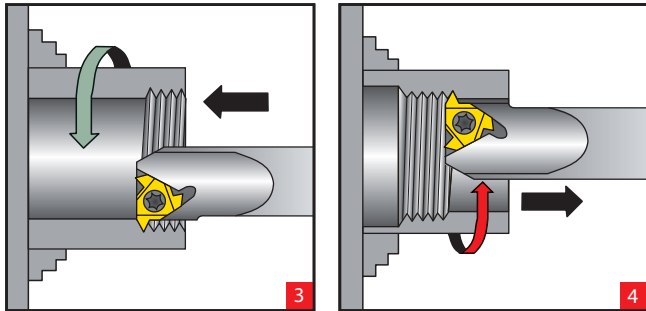

Internal LH Thread

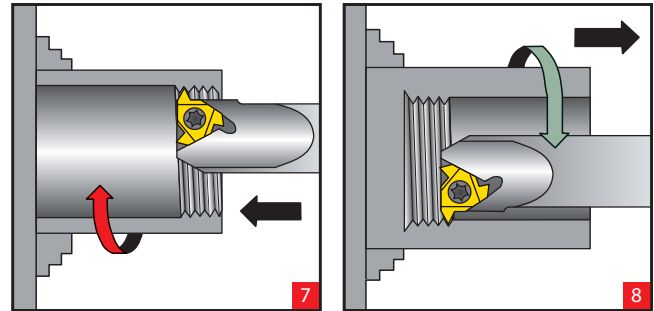

Thread Infeed Methods

Radial Infeed

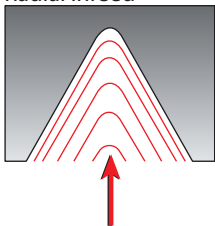

Radial infeed is the simplest and quickest method.

The feed is perpendicular to the turning axis, and both flanks of the insert perform the cutting operation.

Radial infeed is recommended in 3 cases:

- When the pitch is smaller than 16 TPI
- For material with short chips
- For work with hardened material

Flank Infeed (modified)

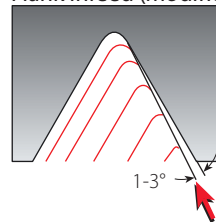

Flank infeed is recommended in the following cases:

- When the thread pitch is greater than 16 TPI, using the radial method, the effective cutting edge length is too large, resulting in chatter.
- For TRAPEZ and ACME. The radial method result in three cutting edges, making chip flow very difficult.

Alternate Flank Infeed

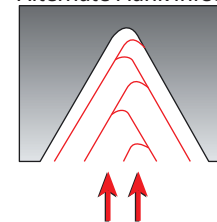

Use of the alternate flank method is recommended especially in large pitches and for materials with long chips. This method divides the load equally on both flanks, resulting in equal wear along the cutting edges. Alternate flank infeed requires more complicated programming, and is not available on all lathes.

Thread Turning Methods for Asymmetrical Inserts (ABUT, BBUT, SAGE)

Thread	Inserts & Toolholder	Rotation	Feed Direction	Helix Method	Drawing No.
Right Hand External	EX RH	Counterclockwise	Towards chuck	Regular	1
	EX LH	Clockwise	From chuck	Reversed	2
Right Hand Internal	IN RH	Counterclockwise	Towards chuck	Regular	3
	IN LH	Clockwise	From chuck	Reversed	4
Left Hand External	EX LH	Clockwise	Towards chuck	Regular	5
	EX RH	Counterclockwise	From chuck	Reversed	6
Left Hand Internal	IN LH	Clockwise	Towards chuck	Regular	7
	IN RH	Counterclockwise	From chuck	Reversed	8

External RH Thread

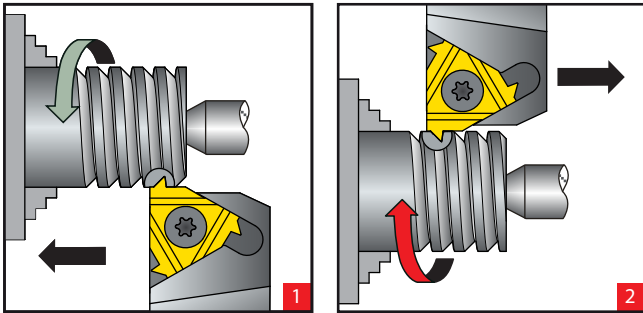

External LH Thread

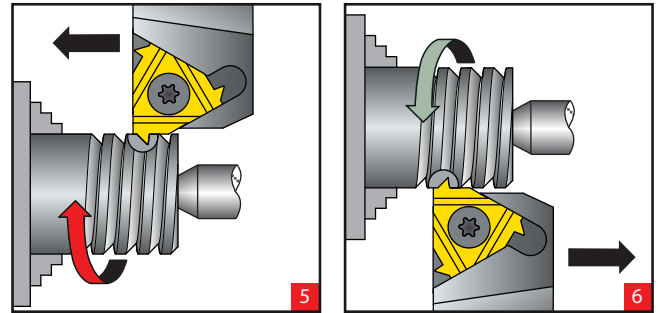

Internal RH Thread

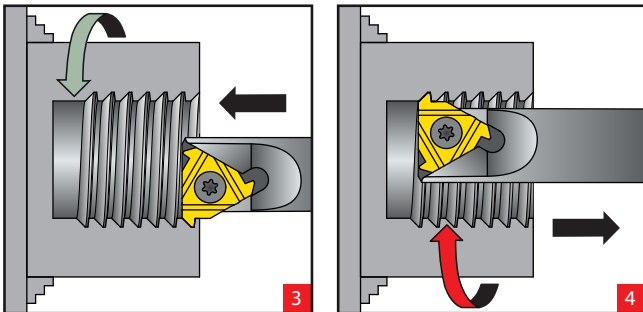

Internal LH Thread

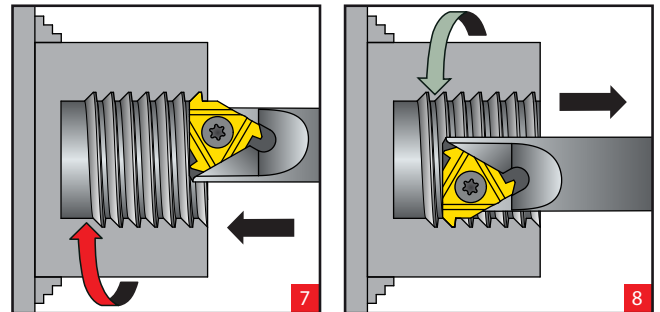

Calculating the Helix Angle and Choosing The Right Anvil

Flank Clearance Angle α (For External Inserts)

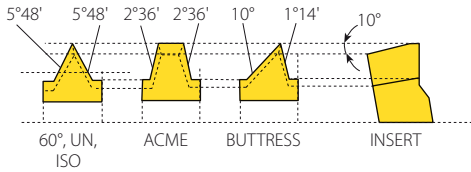

Vardex toolholders are designed to tilt the insert when seated in the toolholder (10° for external, 15° for internal tooling). This results in the differing flank clearance angles, based on the geometry of the insert. To ensure that the side of the insert cutting edge will not rub on the workpiece, it is most important that the insert helix angle be correct - especially in profiles with small enclosed flank angles. This correction is provided by Vardex anvils.

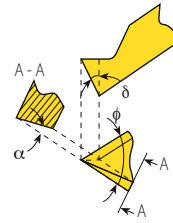

$$\alpha = \arctan(\tan(\phi/2) \times \tan\delta)$$

Where: α - Flank clearance angle
 δ - Tilt angle
 ϕ - Enclosed flank angle

Calculating the Helix Angle β

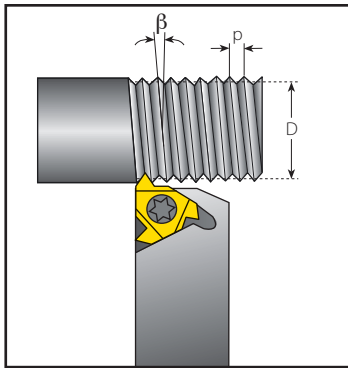

The helix angle is calculated by the following formula:

$$\beta = \arctan \frac{P \times N}{\pi \times D}$$

β - Helix angle [°]
 P - Pitch [mm]
 N - No. of starts
 D - Pitch diameter [mm]
 Lead = P x N

The helix angle can also be found from the diagram below.

Helix Angle Diagram

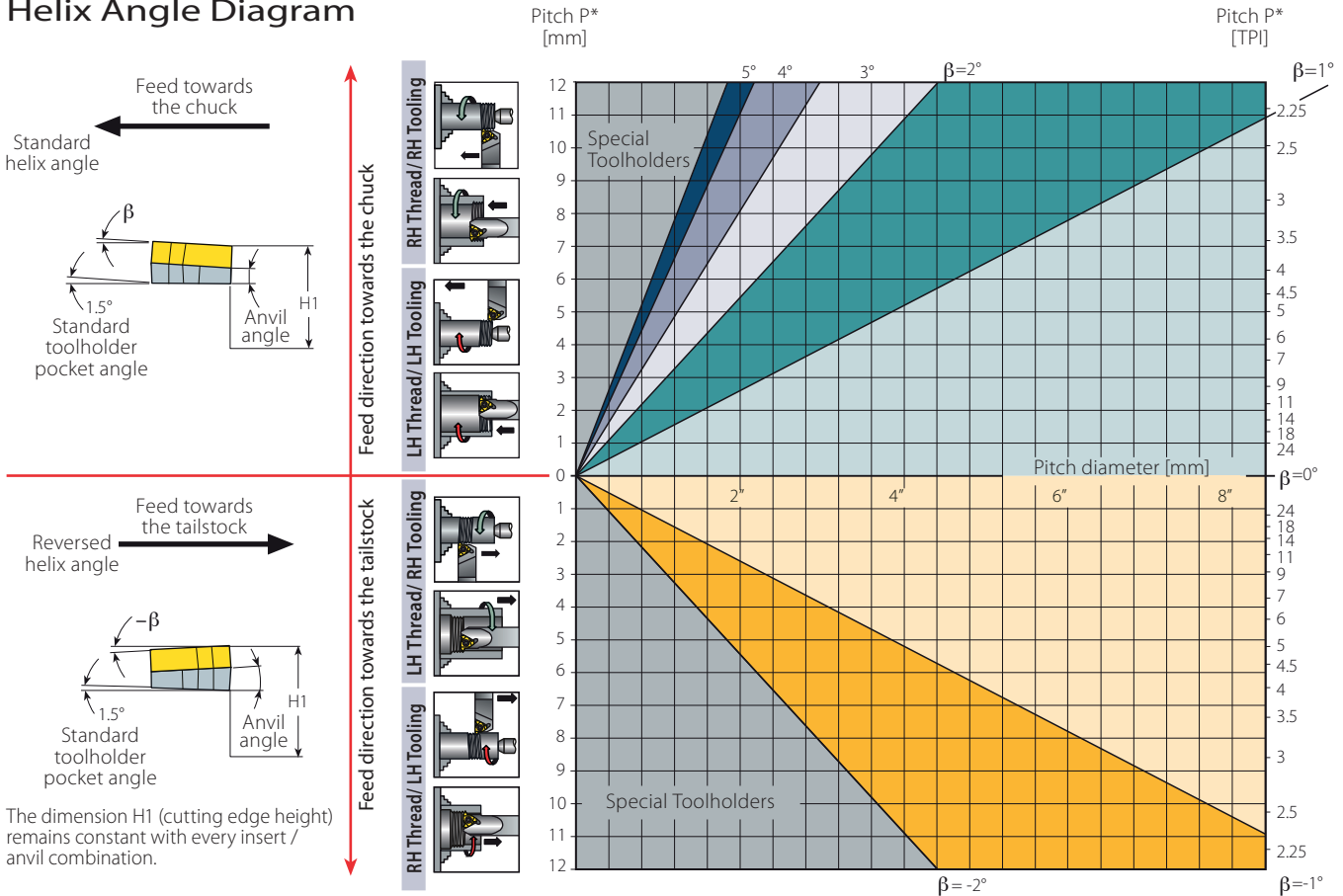

The dimension H1 (cutting edge height) remains constant with every insert / anvil combination.

Anvils

Resultant Helix Angle		4.5°	3.5°	2.5°	1.5°	0.5°	0°	-0.5°	-1.5°	
Insert Size		Holder			Ordering Code					
IC	L Inch									
3/8"	.63	ER / IL	YE3-3P	YE3-2P	YE3-1P	YE3	YE3-1N	YE3-1.5N	YE3-2N	YE3-3N
		EL / IR	YI3-3P	YI3-2P	YI3-1P	YI3	YI3-1N	YI3-1.5N	YI3-2N	YI3-3N
3/8" V6	.63	ER	YE3-6C-3P	YE3-6C-2P	YE3-6C-1P	YE3-6C	YE3-6C-1N	YE3-6C-1.5N	YE3-6C-2N	YE3-6C-3N
		IR	YI3-6C-3P	YI3-6C-2P	YI3-6C-1P	YI3-6C	YI3-6C-1N	YI3-6C-1.5N	YI3-6C-2N	YI3-6C-3N
1/2"	.87	ER / IL	YE4-3P	YE4-2P	YE4-1P	YE4	YE4-1N	YE4-1.5N	YE4-2N	YE4-3N
		EL / IR	YI4-3P	YI4-2P	YI4-1P	YI4	YI4-1N	YI4-1.5N	YI4-2N	YI4-3N
1/2"F	.91	ER	YE4F-3P	YE4F-2P	YE4F-1P	YE4F	YE4F-1N	YE4F-1.5N		
		IR	YI4F-3P	YI4F-2P	YI4F-1P	YI4F	YI4F-1N	YI4F-1.5N		
1/2"U	.87	ER / IL	YE4U-3P	YE4U-2P	YE4U-1P	YE4U	YE4U-1N	YE4U-1.5N	YE4U-2N	YE4U-3N
		EL / IR	YI4U-3P	YI4U-2P	YI4U-1P	YI4U	YI4U-1N	YI4U-1.5N	YI4U-2N	YI4U-3N
5/8"	1.06	ER / IL	YE5-3P	YE5-2P	YE5-1P	YE5	YE5-1N	YE5-1.5N	YE5-2N	YE5-3N
		EL / IR	YI5-3P	YI5-2P	YI5-1P	YI5	YI5-1N	YI5-1.5N	YI5-2N	YI5-3N
5/8"U	1.06	ER / IL	YE5U-3P	YE5U-2P	YE5U-1P	YE5U	YE5U-1N	YE5U-1.5N	YE5U-2N	YE5U-3N
		EL / IR	YI5U-3P	YI5U-2P	YI5U-1P	YI5U	YI5U-1N	YI5U-1.5N	YI5U-2N	YI5U-3N
3/8"M+	.63	ER / IL			YE3M-1P	YE3M	YE3M-1N	YE3M-1.5N	YE3M-2N	
		EL / IR			YI3M-1P	YI3M	YI3M-1N	YI3M-1.5N		
1/2"M+	.87	ER / IL			YE4M-1P	YE4M	YE4M-1N	YE4M-1.5N	YE4M-2N	
		EL / IR			YI4M-1P	YI4M	YI4M-1N	YI4M-1.5N		
1/2"F 2M+	.91	ER			YE4M2F-1P	YE4M2F	YE4M2F-1N	YE4M2F-1.5N		
1/2"F 3M+					YE4M3F-1P	YE4M3F	YE4M3F-1N	YE4M3F-1.5N		
1/2"F 2M+			IR			YI4M2F-1P	YI4M2F	YI4M2F-1N	YI4M2F-1.5N	
5/8"M+	1.06	ER / IL				YE5M	YE5M-1N	YE5M-1.5N		
		EL / IR				YI5M	YI5M-1N	YI5M-1.5N		
1/2"Z+	.87	ER / IL			YE4Z-1P	YE4Z	YE4Z-1N			
		EL / IR			YI4Z-1P	YI4Z	YI4Z-1N			
5/8"Z+	1.06	ER / IL				YE5Z				
		EL / IR				YI5Z				
1/2"T+	.87	ER / IL EL / IR						Y4T		

Thread Turning
Technical Data











Standard Anvil		V6 Anvil		U Style Anvil		M+ Style Anvil		Z+ Style Anvil		T+ Style Anvil	
ER/IL	EL/IR	ER	IR	ER/IL	EL/IR	ER/IL	EL/IR	ER/IL	EL/IR	ER/IL	EL/IR
		V6 is indicated on the backside								Same anvil turned over	

F.LINE Anvil		F.LINE M+ Style Anvil	
ER	IR	ER	IR

Oil&Gas - Anvils

Resultant Helix Angle	3°	2°	1°	0°	0.5°
Insert Size					
3/8" APIRD			YEI3-APIRD		
1/2" API	YEI4-API-3P	YEI4-API-2P	YEI4-API-1P		
1/2" BUT					YEI4-BUT-0.5N

Oil&Gas - 14D Anvils

Standard	Application	Anvils with Protected Second Cutting Edge			
		Ordering Code External Application		Ordering Code Internal Application	
API Round Casing & Tubing	10 TPI from Ø 2 3/8" and up	Y14DER-10APIRD (4 teeth)		Y14DIR-10APIRD (4 teeth)	
	10 TPI from Ø 2 3/8" and up	Y14DER10APIRD-3+ (3 teeth)		Y14DIR10APIRD-3+ (3 teeth)	
	8 TPI from Ø 2 3/8" and up	Y14DER-8APIRD		Y14DIR-8APIRD	
API Buttress Casing	5 TPI for Ø 4 1/2" - Ø 9 5/8"	Y14DER-5 BUT		Y14DIR-5 BUT	
	5 TPI for Ø 10 3/4" and up	Y14DER-5BUT-0.4N		Y14DIR-5BUT-0.4N	

Anvil Kits

Anvil Size		Ordering Code	Included Anvils:
IC	L mm		
3/8"	.63	ABY3	YE3-2P, 1P, 1N, 2N, 3N
			YI3-2P, 1P, 1N, 2N, 3N
3/8" V6	.63	ABY3-6C	YE3-6C-2P, 1P, 1N, 2N, 3N
			YI3-6C-2P, 1P, 1N, 2N, 3N
1/2"	.87	ABY4	YE4-2P, 1P, 1N, 2N, 3N
			YI4-2P, 1P, 1N, 2N, 3N
1/2"U	.87	ABY4U	YE4U-2P, 1P, 1N, 2N, 3N
			YI4U-2P, 1P, 1N, 2N, 3N
5/8"	1.06	ABYE5	YE5-2P, 1P, 1N, 2N, 3N
		ABYI5	YI5-2P, 1P, 1N, 2N, 3N
5/8"U	1.06	ABYE5U	YE5U-2P, 1P, 1N, 2N, 3N
		ABYI5U	YI5U-2P, 1P, 1N, 2N, 3N

To ensure that you always have on hand an assortment of anvils for any job, we recommend that anvil kits be readily available.

Important!

Use a V6 anvil when using a V6 insert.

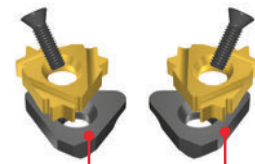

For External RH
use YE3-6C anvil.

For Internal RH
use YI3-6C anvil.



Spare Parts

External and Internal Toolholders (not including Micro and Microscope)

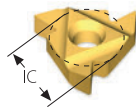







Toolholder	Insert Size	Insert Screw / Clamp Screw		Anvil Screw & Washer		Anvil			
	IC	Designation	Thread	Designation	Thread	Key	Torx size	EX RH/IN LH	IN RH/EX LH
Standard	1/4"	SN2T	M2.6x0.45x6.5	-	-	K2T	T8	-	-
	3/8", 3/8"V6	SA3T	5-40UNCx11.3	SY3T	UNC5x7.3	K3T	T10	YE3/YE3-6C	Y13/Y13-6C
	3/8"	SN3T	5-40UNCx8.8	-	-	K3T	T10	-	-
	1/2"	SA4T	8-32UNCx14.0	SY4T	UNC8x9.3	K4T	T20	YE4	Y14
	1/2"	SN4T	8-32UNCx11.0	-	-	K4T	T20	-	-
	1/2F"	SA4T	8-32UNCx14.0	SY4T	UNC8x9.3	K6T	T20	YE4F	Y14F
	5/8"	SA5T	M5x0.8x22.0	SY5T	M5x0.8x9.5	K5T	T25	YE5	Y15
	5/8"	SN5T	M5x0.8x13.9	-	-	K5T	T25	-	-
Standard Coarse	3/8"	SN3TM	5-40UNCx7.3	-	-	K3T	T10	-	-
	1/2"	SN4TM	8-32UNCx9.8	-	-	K4T	T20	-	-
	5/8"	SN5TM	M5x0.8x13.9	-	-	K5T	T25	-	-
Standard with Clamp	3/8"	SA3T/C3	UNC5x12.0/M5x0.8x22.0	SY3T	UNC5x7.3	K3CT	T15/T10	YE3	Y13
	1/2"	SA4T/C4	UNC8x15.2/M6x1.0x29.5	SY4T	UNC8x9.3	K4T	T20	YE4	Y14
	5/8"	SA5T/C5	M5x0.8x22.0/M8x1.25x28.0	SY5T	M5x0.8x9.5	K5T	T25	YE5	Y15
U Style	1/2"U	SA4T	UNC8x15.2	SY4T	UNC8x9.3	K4T	T20	YE4U	Y14U
	5/8"U	SA5T	M5x0.8x22.0	SY5T	M5x0.8x9.5	K5T	T25	YE5U	Y15U
U Style with Clamp	1/2"	SA4T/C4	UNC8x15.2/M6x1.0x29.5	SY4T	UNC8x9.3	K4T	T20	YE4U	Y14U
	5/8"	SA5T/C5	M5x0.8x22.0/M8x1.25x28.0	SY5T	M5x0.8x9.5	K5T	T25	YE5U	Y15U
V Style	1/4"V	SN2T	M2.6x0.45x6.5	-	-	K2T	T8	-	-
	3/8"V	SN3TV	5-40UNCx6.7	-	-	K3T	T10	-	-
	1/2"V	SN4T	8-32UNCx11.0	-	-	K4T	T20	-	-
	5/8"V	SN6T	M6x1.0x29.0	-	-	K6T	T20	-	-
Mega Line	5/8"MG	S5MG	M5x0.8x16.0	-	-	K6T	T20	-	-
Z+ Style	1/2"Z	SA4T	UNC8x15.2	SY4T	UNC8x9.3	K4T	T20	YE4Z	Y14Z
	5/8"Z	SA5T	M5x0.8x22.0	SY5T	M5x0.8x9.5	K5T	T25	YE5Z	Y15Z
M+ Style	3/8"M	SA3T	UNC5x12.0	SY3T	UNC5x7.3	K3T	T10	YE3M	Y13M
	1/2"M	SA4T	UNC8x15.2	SY4T	UNC8x9.3	K4T	T20	YE4M	Y14M
	5/8"M	SA5T	M5x0.8x22.0	SY5T	M5x0.8x9.5	K5T	T25	YE5M	Y15M
T+ Style	1/2"T	SA4T	UNC8x15.2	SY4K2	UNC8x7.3	K4T/K2	T20/T8	Y4T	Y4T
API	5/8"	SA5T/C5	M5x0.8x22.0/M8x1.25x28.0	SY5T	M5x0.8x9.5	K5T	T25	YE5OIL	Y15OIL
API 14D	14D	SA5T	M5x0.8x22.0	M4x0.7x6.0 (14D)	-	K5T/KT15	T25/T15	Y14DER-...	Y14DIR-...
Mini-V	V08	SNV08	M2.6x0.45x8	-	-	K2T	T8	-	-
	V11	SNV11	M3.5x0.6x10	-	-	K3T	T10	-	-
	V14	SNV14	M4x0.7x12	-	-	KT15	T15	-	-
	V16	SNV16	M5x0.8x12	-	-	K4T	T20	-	-
Mini-L	5.0L	SN5LSTR	M2.2x0.45x4.5	-	-	K7MT	T7	-	-
Mini-3	4.0mm	SN4MT	M2x0.4x4.0	-	-	K6MT	T6	-	-
	5.0mm	SN5MT	M2x0.4x5.3	-	-	K6MT	T6	-	-
	6.0mm	SN6MTN	M2.0x0.4x4.7	-	-	KIP6	T+6	-	-
Mini Adjustable Holder	-	S4.0	M4x0.7x4.0	-	-	K2.0	-	-	-

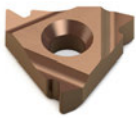

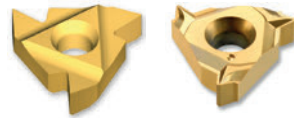
For Micro and Microscope Toolholders see pages 187-191

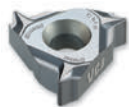
Grades and Their Applications

Thread Turning
Technical Data

General Use		
VRX	VTX	VKX
 <p>Premium multipurpose submicron grade for stronger wear resistance and improved productivity. AlTiN alloyed PVD coated.</p>	 <p>General purpose grade with tough submicron substrate. Provides good fracture toughness in non-rigid cutting conditions. TiAlN coated.</p>	 <p>General purpose grade, excellent in steel and stainless steel, recommended for rigid cutting conditions. Ground or sintered chipbreaker styles. TiN coated.</p>

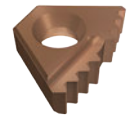
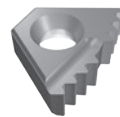
General Use	Stainless Steel	Non Ferrous, High Temperature Alloys and Titanium	
VCB	VM7	VK2	VK2P
 <p>Sintered chipbreaker with ground profile for machining materials with long chips. TiAlN coated.</p>	 <p>Specialty grade for threading stainless steel. Multi-layer PVD coated.</p>	 <p>Uncoated grade for non-ferrous, aluminum, high temperature and titanium alloys.</p>	 <p>Highly-polished version of the VK2 uncoated grade for high quality surface finish in aluminum.</p>

VG-Cut	Oil&Gas	General Use for Oil & Gas Materials	
VPG	VRXP	VTXP	VKXP
 <p>Sub-micron substrate for a wide range of applications. Excellent anti-fracture resistance. Highly recommended for medium to high cutting speeds. TiAlN coated.</p>	 <p>Premium submicron grade with reinforced cutting edge for the oil & gas industry. Ideal for steel and stainless steel in unstable cutting conditions. AlTiN alloyed PVD coated.</p>	 <p>Excellent all-purpose grade, tailor-made to the oil & gas industry with reinforced cutting edge. Recommended for non-rigid cutting conditions. TiAlN coated.</p>	 <p>General purpose grade, excellent in steel and stainless steel, and highly recommended for rigid cutting conditions. Special design with reinforced cutting edge for the oil & gas industry. TiN coated.</p>

Micro Line	MINIPRO	For all Mini Inserts
VMX		VTX
 <p>General purpose carbide grade for Micro double-ended inserts. TiN coated.</p>		 <p>Sub-micron grade for general machining in low and medium cutting speeds. Highly recommended for stainless steel. TiAlN coated.</p>

microscope	Mini 5L & Mini IC 6.0	Mini IC4.0, IC5.0 & Mini-V
VBX	VKX	VBX
 <p>General purpose carbide grade for microScope threading inserts. TiCN coated.</p>	 <p>General purpose carbide grade for the Mini 5L and Mini 6.0 inserts. TiN coated.</p>	 <p>Sub-micron grade for general machining in low and medium cutting speeds for Mini 4.0K, 5.0K and Mini-V lines. Highly recommended for steel. TiCN coated.</p>

Thread Turning Grades According to Product Lines

General

Insert Style	VRX	VTX	VKX	VCB	VM7	VK2	VK2P	VPG
TT inserts (General)	✓	✓	✓		✓	✓	✓	
SCB (Sintered Chipbreaker)			✓	✓				
V6			✓					
Mega Line			✓					
F Line	✓	✓						
VG Cut								✓

Oil & Gas



Insert Style	VRX	VTX	VKX	VRXP	VTXP	VKXP
T+		✓	✓		✓	✓
14D	✓	✓	✓	✓	✓	✓
CNGA		✓			✓	
On Edge		✓			✓	
Chaser		✓			✓	✓

MiniPro



Insert Style	VKX	VTX	VBX	VMX
Mini 4.0K, 5.0K		✓	✓	
Mini 5LK, 6.0K RH	✓	✓		
Mini 5LK, 6.0K LH	✓			✓
Mini-V		✓	✓	
Micro (Double Ended)				✓
Microscope (Single Ended)			✓	

Recommended Grades and Cutting Speeds Vc [ft/min] Not Including MiniPro Line

Material Group	Vargus No.	Material	Hardness Brinell HB	Vc [ft/min]					
				Coated				Uncoated	
				VKX(P)	VCB	VM7	VTX(P), VRX(P)	VK2(P)	
P Steel	1	Unalloyed Steel	Low Carbon (C=0.1-0.25%)	125	377-623	377-623		377-623	
	2		Medium Carbon (C=0.25-0.55%)	150	328-574	328-541		328-574	
	3		High Carbon (C=0.55-0.85%)	170	295-541	295-509		295-541	
	4	Low Alloy Steel (alloying elements ≤5%)	Non Hardened	180	328-591	328-591		328-591	
	5		Hardened	275	246-459	246-459		246-459	
	6		Hardened	350	230-443	230-443		230-443	
	7	High Alloy Steel (alloying elements >5%)	Annealed	200	262-394	262-394		262-394	
	8		Hardened	325	164-328	164-328		164-328	
	9	Cast Steel	Low Alloy (alloying elements <5%)	200	230-427	230-427		230-427	
	10		High Alloy (alloying elements >5%)	225	197-394	197-394		197-394	
M Stainless Steel	11	Stainless Steel Ferritic	Non Hardened	200	230-427	230-427	230-492	230-427	
	12		Hardened	330	197-377	164-312	197-410	197-377	
	13	Stainless Steel Austenitic	Austenitic	180	295-459	262-394	295-525	295-459	
	14		Super Austenitic	200	131-361	98-328	131-394	131-361	
	15	Stainless Steel Cast Ferritic	Non Hardened	200	295-394	295-394	295-492	295-394	
	16		Hardened	330	213-361	213-361	213-394	213-361	
	17	Stainless Steel Cast Austenitic	Austenitic	200	279-361	279-361	279-394	279-361	
	18		Hardened	330	197-328	197-328	197-361	197-328	
K Cast Iron	28	Malleable Cast Iron	Ferritic (short chips)	130	197-230	230-394		197-230	
	29		Pearlitic (long chips)	230	197-476	230-394		197-476	
	30	Grey Cast Iron	Low Tensile Strength	180	230-427	230-427		230-427	
	31		High Tensile Strength	260	197-377	197-328		197-377	
	32	Nodular Sg Iron	Ferritic	160	410-525	410-525		410-525	
	33		Pearlitic	260	295-394	295-394		295-394	
N Non-Ferrous Metals	34	Aluminium Alloys Wrought	Non Aging	60	328-1198	328-820		328-1198	328-820
	35		Aged	100	262-722	262-591		262-722	262-525
	36	Aluminium Alloys Cast	Cast	75	656-1312	656-1312		656-1312	262-394
	37		Cast & Aged	90	656-919	656-919		656-919	230-328
	38	Aluminium Alloys Cast Si 13-22%	130	197-591	197-492		197-591	164-394	
	39	Copper and Copper Alloys	Brass	90	262-738	262-689		262-738	230-558
	40		Bronze And Non Leaded Copper	100	262-837	262-689		262-837	230-558
	S Heat Resistant Material	19	High Temperature Alloys	Annealed (iron based)	200	148-197	148-197		148-197
20		Aged (iron based)		280	98-164	98-164		98-164	82-131
21		Annealed (nickel or cobalt based)		250	66-98	66-98		66-98	66-98
22		Aged (nickel or cobalt based)		350	49-82	49-82		49-82	49-82
23		Titanium Alloys	Pure 99.5 Ti	400Rm	459-558	459-558		459-558	197-328
24			αβ Alloys	1050Rm	164-230	164-230		164-230	131-197
H Hardened Material	25	Extra Hard Steel	Hardened & Tempered	45-50HRc	148-197	148-197		148-197	
	26			51-55HRc	131-164	131-164		131-164	

Calculation of N [RPM]

$$N = \frac{12 \times V_c}{\pi \times D}$$

$$V_c = \frac{N \times \pi \times D}{12}$$

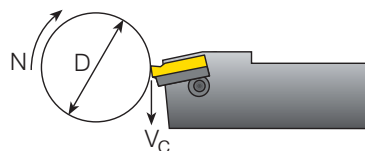

N - Revolution Per Minute [RPM]
V_c - Cutting Speed [ft/min]
D - Workpiece Diameter [Inch]

Recommended Grades and Cutting Speeds Vc [ft/min] **MINIPRO** Mini, Micro and Microscope

Material Group	Vargus No.	Material	Hardness Brinell HB	Vc [ft/min] Coated			
				VMX (Micro)	VBX (Microscope)	VKX/VBX VTX (Mini)	
P Steel	1	Unalloyed Steel	Low Carbon (C=0.1-0.25%)	125	164-394	459-656	131-262
	2		Medium Carbon (C=0.25-0.55%)	150	131-328	394-591	131-262
	3		High Carbon (C=0.55-0.85%)	170	98-262	361-591	131-262
	4	Low Alloy Steel (alloying elements ≤5%)	Non Hardened	180	164-230	328-509	131-262
	5		Hardened	275	131-197	295-476	131-262
	6		Hardened	350	98-164	262-443	131-262
	7	High Alloy Steel (alloying elements >5%)	Annealed	200	98-164	213-377	131-197
	8		Hardened	325	82-131	164-328	131-197
	9	Cast Steel	Low Alloy (alloying elements <5%)	200	98-164	98-164	131-197
	10		High Alloy (alloying elements >5%)	225	82-131	82-131	131-197
M Stainless Steel	11	Stainless Steel Ferritic	Non Hardened	200	197-328	262-394	131-197
	12		Hardened	330	131-197	180-312	131-197
	13	Stainless Steel Austenitic	Austenitic	180	164-295	197-328	131-197
	14		Super Austenitic	200	131-197	164-295	131-197
	15	Stainless Steel Cast Ferritic	Non Hardened	200	131-197	197-262	131-197
	16		Hardened	330	98-164	148-213	131-197
	17	Stainless Steel Cast Austenitic	Austenitic	200	131-197	164-230	131-197
	18		Hardened	330	98-164	131-197	131-197
K Cast Iron	28	Malleable Cast Iron	Ferritic (short chips)	130	164-230	197-262	131-262
	29		Pearlitic (long chips)	230	164-230	197-262	131-262
	30	Grey Cast Iron	Low Tensile Strength	180	164-230	197-262	131-262
	31		High Tensile Strength	260	131-197	131-230	131-262
	32	Nodular Sg Iron	Ferritic	160	164-230	197-262	131-262
	33		Pearlitic	260	197-262	230-295	131-262
N Non-Ferrous Metals	34	Aluminium Alloys Wrought	Non Aging	60	328-984	262-787	131-394
	35		Aged	100	328-492	328-558	131-394
	36	Aluminium Alloys	Cast	75	328-492	328-492	131-394
	37		Cast & Aged	90	197-328	197-328	131-394
	38	Aluminium Alloys	Cast Si 13-22%	130	328-492	328-492	131-394
	39	Copper and Copper Alloys	Brass	90	197-328	262-656	131-394
	40		Bronze And Non Leaded Copper	100	197-328	262-656	131-394
S Heat Resistant Material	19	High Temperature Alloys	Annealed (iron based)	200	82-148	82-148	98-148
	20		Aged (iron based)	280	66-98	66-98	66-98
	21		Annealed (nickel or cobalt based)	250	49-66	49-66	49-66
	22		Aged (nickel or cobalt based)	350	33-49	33-49	49-66
	23	Titanium Alloys	Pure 99.5 Ti	400Rm	197-328	197-328	230-328
	24		α+β Alloys	1050Rm	131-164	131-164	131-164
H Hardened Material	25	Extra Hard Steel	Hardened & Tempered	45-50HRc	66-131	66-131	66-131
	26			51-55HRc	66-131	66-131	66-131

Recommended Grades and Cutting Speeds Vc [ft/min] **VG-Cut**

Thread Turning
Technical Data

Material Group	Vargus No.	Material	Hardness Brinell HB	Vc [ft/min]	
					VPG
P Steel	1	Unalloyed Steel	Low Carbon (C=0.1-0.25%)	125	394-853
	2		Medium Carbon (C=0.25-0.55%)	150	295-722
	3		High Carbon (C=0.55-0.85%)	170	295-722
	4	Low Alloy Steel (alloying elements ≤5%)	Non Hardened	180	295-722
	5		Hardened	275	197-525
	6		Hardened	350	164-328
	7	High Alloy Steel (alloying elements >5%)	Annealed	200	295-722
	8		Hardened	325	164-328
	9	Cast Steel	Low Alloy (alloying elements <5%)	200	295-722
	10		High Alloy (alloying elements >5%)	225	197-525
M Stainless Steel	11	Stainless Steel Ferritic	Non Hardened	200	197-525
	12		Hardened	330	164-459
	13	Stainless Steel Austenitic	Austenitic	180	197-525
	14		Super Austenitic	200	197-525
	15	Stainless Steel Cast Ferritic	Non Hardened	200	197-525
	16		Hardened	330	164-459
	17	Stainless Steel Cast Austenitic	Austenitic	200	197-525
	18		Hardened	330	164-459
K Cast Iron	28	Malleable Cast Iron	Ferritic (short chips)	130	525-787
	29		Pearlitic (long chips)	230	459-722
	30	Grey Cast Iron	Low Tensile Strength	180	525-787
	31		High Tensile Strength	260	328-656
	32	Nodular Sg Iron	Ferritic	160	328-656
	33		Pearlitic	260	328-656
N Non-Ferrous Metals	34	Aluminium Alloys Wrought	Non Aging	60	656-1476
	35		Aged	100	656-1148
	36	Aluminium Alloys	Cast	75	656-1476
	37		Cast & Aged	90	656-1476
	38	Aluminium Alloys	Cast Si 13-22%	130	656-1148
	39	Copper and Copper Alloys	Brass	90	656-1476
	40		Bronze And Non Leaded Copper	100	656-1476
	S Heat Resistant Material	19	High Temperature Alloys	Annealed (iron based)	200
20		Aged (iron based)		280	66-164
21		Annealed (nickel or cobalt based)		250	66-164
22		Aged (nickel or cobalt based)		350	66-164
23		Titanium Alloys	Pure 99.5 Ti	400Rm	98-164
24			α+β Alloys	1050Rm	98-230
H Hardened Material	25	Extra Hard Steel	Hardened & Tempered	45-50HRc	66-131
	26			51-55HRc	49-98

Recommended Grades, Cutting Speeds Vc [ft/min]













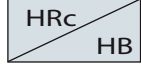



Mini-V

Material Group	Vargus No.	Material	Hardness Brinell HB	Vc [ft/min]	
				VBX / VTX*	
P Steel	1	Unalloyed Steel	Low Carbon (C=0.1-0.25%)	125	131-262
	2		Medium Carbon (C=0.25-0.55%)	150	131-262
	3		High Carbon (C=0.55-0.85%)	170	131-262
	4	Low Alloy Steel (alloying elements≤5%)	Non Hardened	180	131-262
	5		Hardened	275	131-262
	6		Hardened	350	131-262
	7	High Alloy Steel (alloying elements>5%)	Annealed	200	131-197
	8		Hardened	325	131-197
	9	Cast Steel	Low Alloy (alloying elements <5%)	200	131-197
	10		High Alloy (alloying elements >5%)	225	131-197
M Stainless Steel	11	Stainless Steel Ferritic	Non Hardened	200	131-197
	12		Hardened	330	131-197
	13	Stainless Steel Austenitic	Austenitic	180	131-197
	14		Super Austenitic	200	131-197
	15	Stainless Steel Cast Ferritic	Non Hardened	200	131-197
	16		Hardened	330	131-197
	17	Stainless Steel Cast Austenitic	Austenitic	200	131-197
	18		Hardened	330	131-197
K Cast Iron	28	Malleable Cast Iron	Ferritic (short chips)	130	131-262
	29		Pearlitic (long chips)	230	131-262
	30	Grey Cast Iron	Low Tensile Strength	180	131-262
	31		High Tensile Strength	260	131-262
	32	Nodular Sg Iron	Ferritic	160	131-262
	33		Pearlitic	260	131-262
N Non-Ferrous Metals	34	Aluminium Alloys Wrought	Non Aging	60	131-394
	35		Aged	100	131-394
	36	Aluminium Alloys	Cast	75	131-394
	37		Cast & Aged	90	131-394
	38	Aluminium Alloys	Cast Si 13-22%	130	131-394
	39	Copper and Copper Alloys	Brass	90	131-394
	40		Bronze And Non Leaded Copper	100	131-394
S Heat Resistant Material	19	High Temperature Alloys	Annealed (iron based)	200	66-98
	20		Aged (iron based)	280	66-98
	21		Annealed (nickel or cobalt based)	250	49-66
	22		Aged (nickel or cobalt based)	350	33-49
	23	Titanium Alloys	Pure 99.5 Ti	400Rm	131-197
24	α+β Alloys		1050Rm	66-98	
H Hardened Material	25	Extra Hard Steel	Hardened & Tempered	45-50HRc	49-65
	26			51-55HRc	49-65

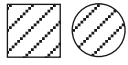
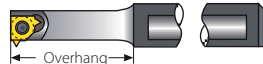
* Available for sizes V08 and V11. Sizes V14 and V16 are available upon request.

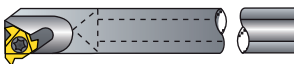
Thread Turning
Technical Data

Cutting Conditions Parameters

Workpiece	Material Type	
	Material Dimension: Diameter and Length	
	Chipflow Character	
	Material Hardness	
Thread Application	External or Internal	
	Profile Shape	
	Surface Finish	
Machine	Machine Stability	
	Max. RPM	
	Clamping System Stability	
Coolant	Coolant Type	
Holders	Holder Cross Section Area	
	Holder Overhang	
	Through Coolant Option	
	Shank Type: Carbide, Alloy, Carbide Implant	
Insert	Grade	
	Profile Shape: Pitch and Depth	
	Nose Radius	
	Chipbreaker Style	

Number of Passes

Pitch	mm	0.50	0.75	1.00	1.25	1.50	1.75	2.00	2.50	3.00	3.50	4.00	4.50	5.00	5.50	6.00	8.00
	TPI	48	32	24	20	16	14	12	10	8	7	6	5.5	5	4.5	4	3
No. of passes		4-6	4-7	4-8	5-9	6-10	7-12	7-12	8-14	9-16	10-18	11-18	11-19	12-20	12-20	12-20	15-24
No. of passes (SCB)		3-4	3-4	3-5	4-6	5-6	6-8	6-8	8-10	9-12	10-14						
No. of passes (Micro / Microscope & Mini)		6-9	6-11	6-12	8-14	9-15	11-18	11-18									

Depths of Cut and Number of Passes for Mini-V

1. Intensive coolant is strongly recommended.
2. Infeed method - modified flank infeed 1°.
3. Number of passes can be decreased when high pressure cooling is used.

Option of modified volume chip

Mini-V

Pitch mm		0.5	0.75	1	1.25	1.5	1.75	2	2.5	3	3.5	4				
Pitch TPI		48	32	27	24	20	19	18	16	14	12	10	8	7	6	
Insert Style	Standard	Passes (modified volume)														
V08	ISO															
	UN	13	19		25	16			19	22						
	W															
	NPT			28				43								
	NPTF															
V11	ISO															
	UN	13	19		25	16			19	22	24					
	W															
	BSPT						19									
V14	ISO															
	UN	7	10		13	16			19	22	24	32	38			
	W															
V16	ISO															
	UN	7	10		13	16			19	22	24	32	38			
	W															

Option of constant depth chip

Mini-V

Pitch mm		0.5	0.75	1	1.25	1.5	1.75	2	2.5	3	3.5	4				
Pitch TPI		48	32	27	24	20	19	18	16	14	12	10	8	7	6	
Insert Style	Standard	Passes (same)														
V08	ISO															
	UN	11-24	17-35		23-48	18-28			21-34	25-40						
	W															
	NPT			25-53				40-83								
	NPTF															
V11	TR									50-104	70-145					
	ISO															
	UN	11-24	17-35		23-48	14-28			17-34	20-40	23-46					
	W															
	BSPT						21-34									
V14	TR															90-187
	ISO															
	UN	11-24	17-35		23-48	14-28			9-15	11-18	11-18	12-21	18-24			
V16	W															
	ISO															
	UN	11-24	17-35		23-48	14-28			9-15	11-18	11-18	12-21	18-24			
V16	W															
	ISO															

Number of Passes and Depth of Cut per Pass for Multi+ Inserts



Thread Turning
Technical Data

Standard	Insert Type	Insert Size		Pitch	Teeth	Ordering Code	Passes	Depth of cut per pass				
		IC	L Inch					RH				
							1	2	3	4		
ISO External	M+	3/8"	.63	1.0 mm	3	3ER1.0ISO3M+...	2	.013	.012			
				1.5 mm	2	3ER1.5ISO2M+...	3	.013	.012	.011		
				2.0 mm	2	3ER2.0ISO2M+...	3	.018	.016	.015		
		1/2"	.87	1.5 mm	3	4ER1.5ISO3M+...	2	.019	.018			
				2.0 mm	2	4ER2.0ISO2M+...	3	.018	.016	.015		
				2.0 mm	3	4ER2.0ISO3M+...	2	.025	.023			
	2.5 mm	2	4ER2.5ISO2M+...	4	.018	.017	.015	.014				
	5/8"	1.06	3.0 mm	2	5ER3.0ISO2M+...	4	.021	.019	.018	.015		
	T+	1/2" T	.87	1.5 mm	8	4ER1.5ISO8T+...	1	.037				
				2.0 mm	8	4ER2.0ISO8T+...	1	.048				
ISO Internal	M+	3/8"	.63	1.0 mm	3	3IR1.0ISO3M+...	2	.012	.011			
				1.5 mm	2	3IR1.5ISO2M+...	3	.012	.011	.011		
				2.0 mm	2	3IR2.0ISO2M+...	3	.017	.015	.014		
		1/2"	.87	1.5 mm	3	4IR1.5ISO3M+...	2	.018	.016			
				2.0 mm	2	4IR2.0ISO2M+...	3	.017	.015	.014		
				2.0 mm	3	4IR2.0ISO3M+...	2	.023	.022			
	2.5 mm	2	5IR3.0ISO2M+...	4	.019	.018	.017	.015				
	T+	1/2"	.87	1.5 mm	8	4IR1.5ISO8T+...	1	.034				
				2.0 mm	8	4IR2.0ISO8T+...	1	.045				
	UN External	M+	3/8"	.63	20 TPI	3	3ER20UN3M+...	2	.016	.015		
18 TPI					2	3ER18UN2M+...	3	.013	.011	.011		
18 TPI					3	3ER18UN3M+...	2	.018	.017			
16 TPI					2	3ER16UN2M+...	3	.014	.013	.012		
14 TPI					2	3ER14UN2M+...	3	.017	.015	.015		
12 TPI					2	3ER12UN2M+...	3	.019	.017	.016		
1/2"			.87	16 TPI	3	4ER16UN3M+...	2	.020	.019			
				14 TPI	2	4ER14UN2M+...	3	.017	.015	.015		
				12 TPI	2	4ER12UN2M+...	3	.019	.017	.016		
				12 TPI	3	4ER12UN3M+...	2	.026	.025			
11 TPI		2	4ER11UN2M+...	4	.017	.015	.014	.013				
10 TPI		2	4ER10UN2M+...	4	.018	.017	.016	.014				
5/8"		1.06	8 TPI	2	5ER8UN2M+...	4	.022	.020	.019	.016		
UN Internal		M+	3/8"	.63	12 TPI	2	3IR12UN2M+...	3	.018	.015	.015	
	14 TPI				2	3IR14UN2M+...	3	.016	.014	.013		
	16 TPI				2	3IR16UN2M+...	3	.013	.012	.011		
	1/2"		.87	16 TPI	3	4IR16UN3M+...	2	.019	.017			
				14 TPI	2	4IR14UN2M+...	3	.016	.014	.013		
				12 TPI	2	4IR12UN2M+...	3	.018	.015	.015		
	12 TPI	3	4IR12UN3M+...	2	.025	.023						
	5/8"	1.06	8 TPI	2	5IR8UN2M+...	4	.020	.019	.017	.015		
	BSW External	M+	3/8"	.63	28 TPI	2	3ER28W2M+...	3	.009	.008	.008	
					19 TPI	2	3ER19W2M+...	3	.013	.011	.011	
19 TPI					3	3ER19W3M+...	2	.018	.016			
14 TPI					2	3ER14W2M+...	3	.017	.015	.014		
1/2"			.87	14 TPI	3	4ER14W3M+...	2	.024	.022			
				11 TPI	2	4ER11W2M+...	4	.017	.015	.014	.012	

Number of Passes and Depth of Cut per Pass for Multi+ Inserts

Standard	Insert Type	Insert Size		Pitch	Teeth	Ordering Code	Passes	Depth of cut per pass				
		IC	L Inch					RH				
BSW Internal	M+	3/8"	.63	14	TPI	2	3R14W2M+...	3	.017	.015	.014	
		1/2"	.87	11	TPI	2	4R11W2M+...	4	.017	.015	.014	.012
NPT External	M+	3/8"	.63	14	TPI	2	3ER14NPT2M+...	3	.020	.018	.017	
		1/2"	.87	11.5	TPI	2	4ER11.5NPT2M+...	4	.018	.017	.017	.016
		5/8"	1.06	11.5	TPI	3	5ER11.5NPT3M+...	4	.019	.017	.017	.015
	Z+	1/2"	.87	8	TPI	2	4ER11.5NPT2Z+...	4	.018	.017	.017	.016
		1/2"	.87	8	TPI	2	4ER8NPT2Z+...	4	.028	.025	.024	.021
		1/2"	.87	8	TPI	2	4ER8NPT2Z+...	4	.028	.025	.024	.021
NPT Internal	M+	3/8"	.63	14	TPI	2	3IR14NPT2M+...	3	.020	.018	.017	
		1/2"	.87	11.5	TPI	2	4IR11.5NPT2M+...	4	.018	.017	.017	.016
		5/8"	1.06	11.5	TPI	2	5IR11.5NPT3M+...	4	.019	.017	.017	.015
	Z+	1/2"	.87	8	TPI	2	5IR8NPT2M+...	4	.028	.025	.024	.021
		1/2"	.87	11.5	TPI	3	4IR11.5NPT2Z+...	4	.018	.017	.017	.016
		1/2"	.87	8	TPI	2	4IR8NPT2Z+...	4	.028	.025	.024	.021
NPTF External	M+	3/8"	.63	14	TPI	2	3ER14NPTF2M+...	3	.020	.017	.017	
NPTF Internal	M+	3/8"	.63	14	TPI	2	3IR14NPTF2M+...	3	.020	.017	.017	

Thread Turning
Technical Data

Oil&Gas API RD, API BUT, OTTM, OTTG

The following table provides the optimal cutting pass division options, depending on the material, machine stability and clamping conditions:

Application	No. of Passes/ Pass No.	1	2	3	4	5	6
APIRD 8 Ex, In	3 passes	.035	.032	.004			
	4 passes	.024	.023	.020	.004		
	5 passes	.019	.019	.017	.013	.004	
	6 passes	.015	.016	.015	.011	.009	.004
APIRD 10 Ex, In	3 passes	.026	.025	.004			
	4 passes	.017	.018	.016	.004		
	5 passes	.013	.015	.013	.010	.004	
	6 passes	.011	.013	.011	.009	.007	.004
BUT 5 Ex, In	3 passes	.030	.028	.004			
	4 passes	.020	.020	.018	.004		
	5 passes	.016	.016	.015	.011	.004	
	6 passes	.013	.014	.013	.010	.008	.004
OTTM 5 Ex, In OTTG 5 Ex, In	3 passes	.030	.029	.004			
	4 passes	.020	.020	.019	.004		
	5 passes	.016	.016	.015	.012	.004	
	6 passes	.013	.014	.013	.010	.009	.004



M+ Style



Z+ Style



T+ Style



14D Style



CNGA Style

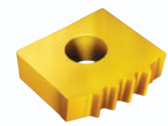

Chaser Style

Cutting Speed Recommendations for Materials Specified by API STB Oil&Gas

Material	J55-K55	N80-L80-C95-TN70	TN95-P110-TN110
Cutting Speed (ft/min)	558-656	492-591	427-525

Step by Step Thread Turning - Example 1

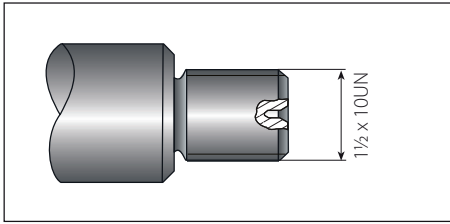

Application:
 Thread: External Right Hand
 1 1/2 x 10UN
 Material: 4140 (25 HRC)

1 Choose the Thread Turning Method

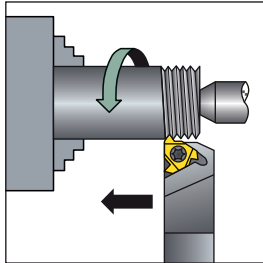

Feed direction towards the chuck was chosen.
 Therefore, an external right hand insert and an external right hand holder will be used.

2 Choose the Insert Size

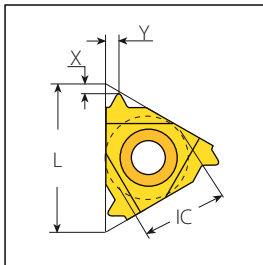

Chosen insert: 3ER10UN

Insert Size		Pitch	Ordering Code	Anvil	Toolholder
IC	L Inch	TPI	RH	RH	
3/8"	.63	10	3ER10UN...	YE3	AL..-3(LH)

3 Choose the Toolholder

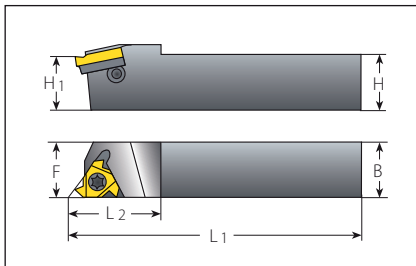

Chosen toolholder: AL100-3

Insert Size		Ordering Code	Dimensions Inch		
IC	RH	H=H1=B	F	L1	L2
3/8"	AL100-3	1.00	1.00	6.05	1.20

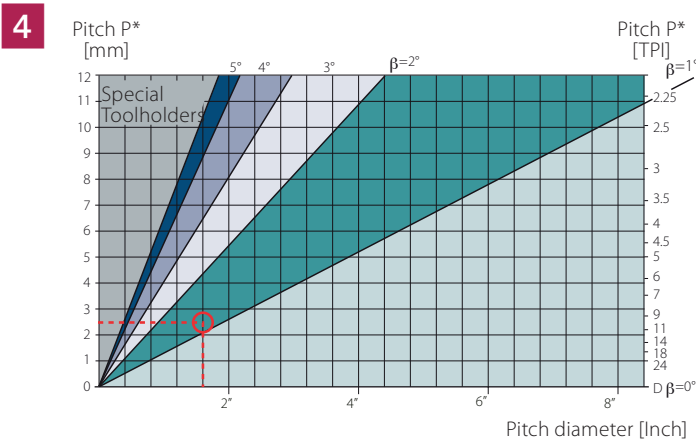

From the table, using a pitch of 2.5 mm (10 TPI) and a workpiece diameter of 40 mm (1.57"), we find the helix angle to be 1.5°.

5 Choose the Correct Anvil

Anvil chosen: YE3

Insert Size		Ordering Code		Holder	Ordering Code	3.5	2.5	1.5	0.5
IC	L Inch								
3/8"	.63	ER/IL	YE3-2P	YE3-1P	YE3	YE3-1N			

6 Choose the Carbide Grade and Cutting Speed

Carbide Grade chosen: VTX

Cutting Speed: 420 ft/min

Material:		Hardness Brinell HB	VTX	VCB
P	Low alloy steel (alloying elements ≤ 5%)	Non hardened	180	328-590
		Hardened	275	246-459
		Hardened	350	230-433

7 Determine the Number of Passes

Number of passes: 14

ISO External

Pitch	mm	1.50	1.75	2.00	2.50	3.00	3.50	4.00
	TPI	16	14	12	10	8	7	6
No. of Passes		6-10	7-12	7-12	8-14	9-16	10-18	11-18

Summary

Thread Type	1½x10UN External Right Hand
1 Feed Direction:	Towards the chuck
2 Insert and Grade:	3ER10UN VTX
3 Toolholder:	AL 100 - 3
4 Helix Angle:	1.5°
5 Anvil:	YE3
6 Cutting Speed:	420 ft/min
7 Number of Passes:	10

Step by Step Thread Turning - Example 2

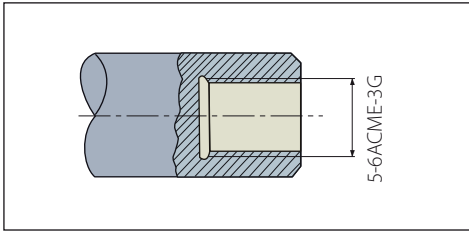

Application:
 Thread: Internal Right Hand
 ACME
 Pitch: 6 TPI
 Bore dia: 5"
 Material: Stainless Steel Austemitic

1 Choose the Thread Turning Method

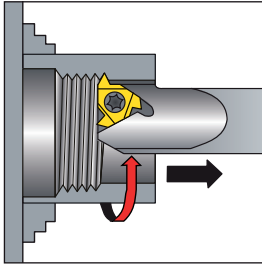

To facilitate the removal of chips from the machined area, we chose a feed direction away from the chuck. Therefore, an internal left hand insert and an internal left hand toolholder are to be used.

2 Choose the Insert Size

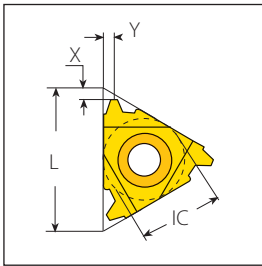

Chosen insert: 4IL6ACME

Insert Size	Pitch	Ordering Code	Anvil	Toolholder
IC	L Inch	TPI	RH	LH
1/2"	.87	6	4IL6ACME...	YE4 AVR..-4(LH)

3 Choose the Toolholder

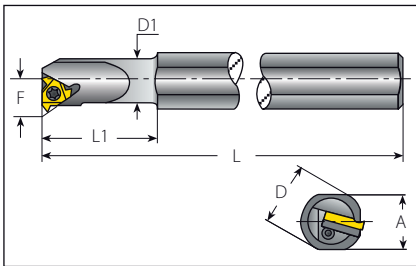

Chosen toolholder: AVR 40-4LH

Insert Size	Ordering Code	Dimensions Inch						Min Bore
IC	RH	A	L	L1	D	D1	F	Inch
1/2"	AVR150-4	1.34	12.00	2.50	1.50	1.50	.98	1.75

4 Determine the Helix Angle

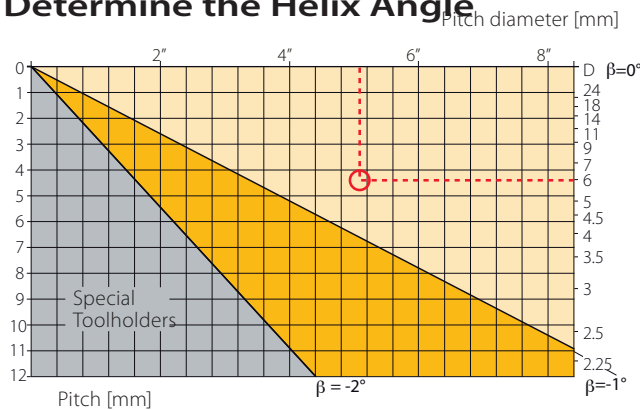

In this case, a right hand thread is being turned with a left hand toolholder. The reverse helix method is used. From the lower part of the table, using a pitch of 6 TPI and a bore diameter of 5", we obtain a helix angle of **-0.65°**.

5 Choose the Correct Anvil

Anvil chosen: YE4-2N

Insert Size		Ordering Code					
IC	L Inch						
1/2"	.87	ER/IL	YE4	YE4-1N	YE4-1.5N	YE4-2N	YE4-3N

6 Choose the Carbide Grade and Cutting Speed

Carbide grade chosen: VTX
Cutting speed: 140 ft/min

	Material:	Hardness Brinell HB	VTX	VCB
M	Stainless Steel Austenitic	Austenitic	180	266-394
		Super Austenitic	200	98-328

7 Determine the Number of Passes

Number of passes: 18

ACME External & Internal

Pitch	mm	3.00	3.50	4.00	4.50	5.00	5.50	6.00
	TPI	8	7	6	5.5	5	4.5	4
No. of Passes		9-16	10-18	11-18	11-19	12-20	12-20	12-20

Summary

Thread Type	5"x6 ACME Internal Right Hand
1 Feed Direction:	Away from the chuck
2 Insert and Grade:	4IL6ACME VTX
3 Toolholder:	AVR 150-4LH
4 Helix Angle:	-0.65°
5 Anvil:	YE4-2N
6 Cutting Speed:	420 ft/min
7 Number of Passes:	18

Material Comparison Table

Material Group	Vargus No.	USA AISI/SAE	Germany W.-Nr.	Germany DIN	Great Britain BS	France AFNOR	Italy UNI
P Steel	1	1015	1.0037	St37-2	Fe360B	E24-2	Fe360 B FU
	1	1020	1.0044	St44-2	Fe430B FN	E28-2	Fe430B FN
	2	ASTM A570Gr.50	1.0050	St50-2	Fe490-2 FN	A50-2	Fe490
	2	-	1.0070	St70-2	Fe690-2 FN	A70-2	Fe690
	1	1015	1.0401	C15	080M15	CC12	C15C16
	1	1020	1.0402	C22	050A20	CC20	C20C21
	2	1035	1.0501	C35	060A35	CC35	C35
	2	1045	1.0503	C45	080M46	CC45	C45
	2	1055	1.0535	C55	070M55	-	C55
	2	1060	1.0601	C60	080A62	CC55	C60
	1	1213	1.0715	95Mn28	230M07	S250	CF9SMn28
	1	12L13	1.0718	95MnPb28	-	S250Pb	CF9SMnPb28
	1	-	1.0722	10SPb20	-	10PbF2	CF10SPb20
	2	1140	1.0726	35S20	212M36	35MF4	-
	2	1215	1.0736	95Mn36	240M07	S300	CF9SMn36
	2	12L14	1.0737	95MnPb36	-	S300Pb	CF9SMnPb36
	2	9255	1.0904	55Si7	250A53	55S7	55Si8
	2	9262	1.0961	60SiCr7	-	60SC7	60SiCr8
	1	1015	1.1141	Ck15	080M15	XC1 2	C16
	2	1039	1.1157	40Mn4	150M36	35M5	-
	2	1025	1.1158	Ck25	-	-	-
	2	1335	1.1167	36Mn5	-	40M5	-
	2	1330	1.1170	28Mn6	150M28	20M5	C28Mn
	2	1035	1.1183	Cf35	060A35	XC38TS	C36
	2	1045	1.1191	Ck45	080M46	XC42	C45
	2	1055	1.1203	Ck55	070M55	XC55	C50
	3	1050	1.1213	Cf53	060A52	XC48TS	C53
	3	1060	1.1221	Ck60	080A62	XC60	C60
	8	1095	1.1274	Ck101	060A96	-	-
	9	-	1.3401	X120Mn12	Z120M12	Z120M12	XG120Mn12
	8	52100	1.3505	100Cr6	534A99	100C6	100Cr6
	8	ASTM A20Gr.A	1.5415	15Mo3	1501-240	15D3	16Mo3KW
	8	4520	1.5423	16Mo5	1503-245-420	-	16Mo5
	4	ASTMA350LF5	1.5622	14Ni6	-	16N6	14Ni6
	8	ASTM A353	1.5662	X8Ni9	1501-509; 510	-	X10Ni9
	8	2515	1.5680	12Ni19	-	Z18N5	-
	5	3135	1.5710	36NiCr6	640A35	35NC6	-
	5	3415	1.5732	14NiCr10	-	14NC11	16NiCr11
	5	3415; 3310	1.5752	14NiCr14	655M13; 655M12	12NC15	-
	5	9840	1.6511	36CrNiMo4	816M40	40NCD3	38NiCrMo4(KB)
	5	8620	1.6523	21NiCrMo2	805M20	20NCD2	20NiCrMo2
	5	8740	1.6546	40NiCrMo22	311-Type7	-	40NiCrMo2(KB)
	5	4340	1.6582	34CrNiMo6	817M40	35NCD6	35NiCrMo6(KB)
	5	-	1.6587	17CrNiMo6	820A16	18NCD6	-
	5	-	1.6657	14NiCrMo134	832M13	-	15NiCrMo13
	2	5015	1.7015	15Cr3	523M15	12C3	-
	5	5132	1.7033	34Cr4	530A32	32C4	34Cr4(KB)
	5	5140	1.7035	41Cr4	530M40	42C4	41Cr4
	5	5140	1.7045	42Cr4	-	-	-
	5	5115	1.7131	16MnCr5	(527M20)	16MC5	16MnCr5
	5	5155	1.7176	55Cr3	527A60	55C3	-
	5	4130	1.7218	25CrMo4	1717CDS110	25CD4	25CrMo4(KB)
	5	4137; 4135	1.7220	34CrMo4	708A37	35CD4	35CrMo4
	5	4140; 4142	1.7223	41CrMo4	708M40	42CD4TS	41CrMo4
	5	4140	1.7225	42CrMo4	708M40	42CD4	42CrMo4
	5	-	1.7262	15CrMo5	-	12CD4	-
	5	ASTM A182; F11; F12	1.7335	13CrMo4 4	1501-620Gr.27	15CD3.5; 15CD4.5	14CrMo4 5
	5	-	1.7361	32CrMo12	722M24	30CD12	32CrMo12
	5	ASTM A182; F22	1.7380	10CrMo9 10	1501-622; Gr.31; 45	12CD9; 10	12CrMo9, 10
	5	-	1.7715	14MoV6 3	1503-660-440	-	-
	5	6150	1.8159	50CrV4	735A50	50CV4	50CrV4
	8	-	1.8509	41CrAlMo7	905M39	40CAD6, 12	41CrAlMo7
	8	-	1.8523	39CrMoV13 9	897M39	-	36CrMoV12
	5	W.110	1.1545	C105W1	-	Y1105	C98KU; C100KU
	5	W.112	1.1663	C125W	-	Y2120	C120KU
	8	L3	1.2067	100Cr6	BL3	Y100C6	-
	10	D3	1.2080	X210Cr12	BD3	Z200Cr12	X210Cr13KU
	10	-	-	-	-	-	X250Cr12KU
	10	-	1.2311	40CrMnMo7	-	-	35CrMo8KU
	10	-	1.2312	40CrMnMoS8-6	-	-	-
	10	H11	1.2343	X38CrMoV5-1	BH11	Z38CDV5	X37CrMoV51 1KU
	10	H13	1.2344	X40CrMoV5-1	BH13	Z40CDV5	X35CrMoV05KU
	10	-	-	-	-	-	X40CrMoV511KU
	10	A2	1.2363	X100CrMoV5-1	BA2	Z1 00CDV5	X100CrMoV51KU
	10	-	1.2367	X38CrMoV5-3	-	Z38CDV5-3	-
	10	D2	1.2379	X155CrVMo 12-1	BD2	Z160CDV12	X155CrVMo12 1 KU
	10	-	1.2419	105WCr6	-	105WC13	10WCr6; 107WCr5KU
	10	-	1.2436	X210CrW12	-	-	X215CrW121KU
	10	S1	1.2542	45WCrV17	BS1	-	45WCrV8KU
	10	H21	1.2581	X30WCrV9 3	BH21	Z30WCV9	X30WCrV9 3KU
	10	-	1.2601	X165CrMoV12	-	-	X165CrMoV12KU
	10	L6	1.2713	55NiCrMoV6	-	55NCDV7	-
	10	-	1.2738	40CrMnNiMo8-6-4	-	-	-
	10	W210	1.2833	100V1	BW2	Y1105V; 100V2	-
	10	-	1.3243	S 6-5-2-5	-	Z85WDKCV-06-05-05-04-02	HS 6-5-2-5
	10	T4	1.3255	S 18-1-2-5	BT4	Z80WKCV-18-05-04-01	X78WCo1805KU
	10	M2	1.3343	S 6-5-2	BM2	Z85WDCV-06-05-04-02	X82WMo0605KU
	10	M7	1.3348	S 2-9-2	-	Z100WCWV-09-04-02-02	HS 2-9-2
	10	T1	1.3355	S 18-0-1	BT1	Z80WCV-18-04-01	X75W18KU

Thread Turning
Technical Data

Sweden SS	Japan JIS	Russia GOST	Spain UNE	Vargus No.
1311	STKM 12A;C	–	Fe360B	1
1412	SM400A;B;C	St4ps;sp	Fe430B FN	1
1550	SS490	St5ps;sp	A490-2	2
–	–	–	A690-2	2
1350	–	–	F.111	1
1450	–	20	1 C 22 ; F.112	1
1550	–	30	F. 113	2
1650	–	45	F.114	2
1655	–	55	F.115	2
–	–	60(G)	–	2
1912	SUM22	–	F.2111-11SMn28	1
1914	SUM22L	–	F.2112-11SMnPb28	1
–	–	–	F.2122-10SPb20	1
1957	–	–	F.210.G	2
–	–	–	F.2113-12SMn35	2
1926	–	–	F.2114-12SMnPb35	2
2085	–	55S2	F.1440-56Si7	2
–	–	–	F.1442-60SiCr8	2
1370	S15C	15	F.1110-C15k ; F.1511-C16k	1
–	–	40G	–	2
–	S25C	25	F.1120-C25k	2
2120	SMn438(H)	35G2 ; 35GL	F.1203-36Mn6 ; F.8212-36Mn5	2
–	SCM1	30G	28Mn6	2
1572	S35C	35	–	2
1672	S45C	45	F.1140-C45k ; F.1142-C48k	2
–	S55C	55	F.1150-C55k	2
1674	S50C	50	–	3
1678	S58C	60 ;60G ;60GA	–	3
1870	SUP4	–	–	8
–	SCMnH/1	110G13L	F.8251-AM-X120Mn12	9
2258	SUJ2	SchCh15	F.1310-100Cr6	8
2912	–	–	F.2601-16Mo3	8
–	–	–	F.2602-16Mo5	8
–	–	–	F.2641-15Ni6	4
–	–	–	F.2645-X8Ni09	8
–	–	–	–	8
–	SNC236	–	–	5
–	SNC415(H)	–	F.1540-15NiCr11	5
–	SNC81 5(H)	–	–	5
–	–	40ChN2MA ; 40ChGNM	F.1280-35NiCrMo4	5
2506	SNCM220(H)	20ChGNM	F.1552-20NiCrMo2 ; F.1534-20NiMo31	5
–	SNCM240	38ChGNM	F.1204-40NiCrMo2 ; F.1205-40NiCrMo2DF	5
2541	–	38Ch2N2MA	F.1272-40NiCrMo7 ;34CrNiMo6	5
–	–	–	F.1560-14NiCrMo13	5
–	–	–	F.1560-14NiCrMo13 ;F.1569-14NiCrMo131	5
–	SCr415(H)	15Ch	–	2
–	SCr430(H)	35Ch	F.8221-35Cr4	5
–	SCr440(H)	40Ch	F.1211-41Cr4DF ; F.1202-42Cr4	5
2245	SCr440	40Ch	F.1202-42Cr4	5
2511	–	18ChG	F.1516-16MnCr5 ; F.1517-16MnCr5	5
–	SUP9(A)	50ChGA	F.1431-55Cr3	5
2225	SCM420	20ChM ; 30ChM	F.8372-AM26CrMo4;F.8330-AM25CrMo4;F.1256-30CrMo4-1	5
2234	SCM432 ; SCCRM3	AS38ChGM;35ChM;35ChML	F.8331-AM34CrMo4;F.823134CrMo4;F.1250-35CrMo4;F.1254-35CrMo4DF	5
2244	SCM440	40ChFA	F.8332-AM42CrMo4;F.8232-42CrMo4;F.1252-40CrMo4	5
2244	SCM440(H)	–	F.8332-AM42CrMo4;F.8232-42CrMo4;F.1252-40CrMo4	5
2216	SCM415(H)	–	F.1551-12CrMo4	5
–	–	12ChM ; 15ChM	F.2631-14CrMo45	5
2240	–	–	F.124.A	5
2218	–	12Ch8	TU.H	5
–	–	–	F.2621-13MoCrV6	5
2230	SUP10	50ChGFA ; 50ChFA	F.1430-51CrV4	5
2940	–	38ChMJuA	F.1740-41CrAlMo7	8
–	–	–	–	8
1880	–	U10A-1;2	F.516	5
–	SK2	U13	F.5123 ; C120	5
–	–	Ch	F.5230 ; 100Cr6	8
–	SKD1	Ch12	F.5212 ; X210 Cr12	10
–	–	–	–	10
–	–	–	–	10
–	–	–	–	10
–	SKD6	4ChMFS	F.5317 ; X37 CrMoV5	10
2242	SKD61	4ChMF1S	F.5318 ; X40CrMoC5	10
–	–	–	–	10
2260	SKD12	–	F.5227 ; X100CrMoV5	10
–	–	–	–	10
2310	SKD11	–	F.520A	10
2140	SKS31;SKS2,SKS3	ChWG	F.5233 ; 105WCr5	10
2312	SKD2	–	F.5213 ; X210CrW12	10
2710	–	5ChW2SF	F.5241 ; 45WCrSi8	10
–	SKD5	3Ch2W8F	F.5323 ; X30WCrV9	10
2310	–	–	F.5211 ; X160CrMoV12	10
–	SKT4	5ChNM	F.520S	10
–	–	–	–	10
–	SKS43	–	–	10
2723	SKH55	2723	R6M5K5	10
–	SKH3	–	F.5530 ; 18-1-1-5	10
2722	SKH9	(R6AM5) ; R6M5	F.5603 ; 6-5-2	10
2782	–	–	F.5607 ; 18-0-1	10
–	SKH2	R18	F.5520 ; 18-0-1	10

P

Material Comparison Table (con't)

Material Group	Vargus No.	USA AISI/SAE	Germany W.-Nr.	Germany DIN	Great Britain BS	France AFNOR	Italy UNI	
M Stainless Steel	12	403	1.4000	X6Cr13	403S17	Z6C13	X6Cr13	
	12	-	1.4001	X7Cr14	-	-	-	
	12	410	1.4006	X10Cr13	410S21	Z10C14	X12Cr13	
	12	430	1.4016	X6Cr17	430S15	Z8C17	X8Cr17	
	12	-	1.4027	G-X20Cr14	420C29	Z20C13M	-	
	12	-	1.4034	X46Cr13	420S45	Z40CM;Z38C13M	X40Cr14	
	12	431	1.4057	X20CrNi172	431S29	Z15CNi6.02	X16CrNi16	
	12	430	1.4104	X12CrMoS17	-	Z10CF17	X10CrS17	
	12	434	1.4113	X6CrMo171	434S17	Z8CD17.01	X8CrMo17	
	12	-	1.4313	X5CrNi134	425C11	Z4CND13.4M	-	
	12	-	1.4408	G-X6CrNiMo18 10	316C16	-	-	
	12	HW3	1.4718	X45CrSi93	401S45	Z45CS 9	X45CrSi8	
	12	405	1.4724	X10CrAl13	403S17	Z10C13	X101CrAl12	
	11	-	1.4742	X10CrAl18	430S15	Z12CAS18	X8Cr17	
	12	HNV6	1.4747	X80CrNiSi20	443S65	Z80CSN20.02	X80CrSiNi20	
	11	446	1.4762	X10CrAl24	-	Z10CAS24	X16Cr26	
	13	304	1.4301	X5CrNi18 10	304S15	Z6CN18.09	X5CrNi1810	
	13	303	1.4305	X10CrNiSi18 9	303S21	Z10CNF 18.09	X10CrNiSi 18.09	
	13	304L	1.4306	X2CrNi19 11	304S12;304C12	Z2CN18.10;Z3CN 19.10	X2CrNi18.11	
	13	CF8	1.4308	G-X6CrNi18 9	304C15	Z6CN18.10M	-	
	13	301	1.4310	X12CrNi177	301S21	Z12CN 17.07	X1 2CrNi1 707	
	13	304LN	1.4311	X2CrNi18 10	304S62	Z2CN18.10	-	
	13	316	1.4401	X5CrNiMo17122	316S16	Z6CND17.11	X5CrNiMo17 12	
	13	316LN	1.4429	X2CrNiMoN17133	-	Z2CND17.13	-	
	13	316L	1.4435	X2CrNiMo18143	316S12	Z2CND17.13	X2CrNiMo17 13	
	13	317L	1.4438	X2CrNiMo17133	317S12	Z2CND19.15	X2CrNiMo18 16	
	13	329	1.4460	X8CrNiMo275	-	-	-	
	12	321	1.4541	X6CrNiTi18 10	2337	Z6CNT18.10	X6CrNiTi18 11	
	12	347	1.4550	X6CrNiNb18 10	347S17	Z6CNNb18.10	X6CrNiNb18 11	
	12	316Ti	1.4571	X6CrNiMoTi17122	320S17	Z6NDT1 7.12	X6CrNiMoTi17 12	
	12	-	1.4581	G-X5CrNiMoNb18 10	318C17	Z4CNDNb18 12M	XG8CrNiMo18 11	
	12	318	1.4583	X10CrNiMoNb18 12	-	Z6CNDNb17 13B	X6CrNiMoNb17 13	
	13	309	1.4828	X15CrNiSi20 12	309S24	Z15CNS20.12	-	
	13	310S	1.4845	X12CrNi25 21	310S24	Z12CN25 20	X6CrNi25 20	
	13	330	1.4864	X12NiCr36 16	-	Z12NCS35.16	-	
	13	-	1.4865	G-X40NiCrSi38 18	330C11	-	XG50NiCr39 19	
	13	EV8	1.4871	X53CrMnNiN2 19	349S54;321S12	Z52CMN21.09	X53CrMnNiN219	
	13	321	1.4878	X12CrNiTi18 9	321S320	Z6CNT18.12B	X6CrNiTi1811	
	K Cast Iron	30	No 20 B	0.6010	GG10	-	Ft 10 D	-
		30	No 25 B	0.6015	GG15	Grade 150	Ft 15 D	-
		30	No 30 B	0.6020	GG20	Grade 220	Ft 20 D	-
		29	No 35 B; No 40 B	0.6025	GG25	Grade 260	Ft 25 D	-
		29	No 45 B	0.6030	GG30	Grade 300	R 30 D	-
		29	No 50 B	0.6035	GG35	Grade 350	Ft 35 D	-
		29	No 55 B	0.6040	GG40	Grade 400	Ft 40 D	-
29		ASTM	-	DIN4694	3468: 1974	-	-	
29		A436-72	-	GGL-	-	A32-301	-	
29		Type 2	-	NiCr20 2	L-NiCr 20 2	L-NC 20 2	-	
30		60-40-18	0.7040	GGG 40	SNG 420/12	FCS 400-12	GS 370-17	
30		-	0.7043	GGG 40.3	SNG 370/17	FGS 370-17	-	
30		-	0.7033	GGG 35.3	-	-	-	
31		80-55-06	0.7050	GGG 50	SNG 500/7	FGS 500-7	GS 500	
31		-	0.7060	GGG 60	SNG 600/3	FGS 600-3	-	
31		100-70-03	0.7070	GGG70	SNG 700/2	FGS 700-2	GS 700-2	
31		-	-	DIN 1694	-	L-NM 13 7	-	
31		Type 2	-	GGG NiMn 13 7	L-NiMn 13 7	L-NC 20 2	-	
31		-	-	GGG NiCr 20 2	L-NC 20 2	-	-	
28		32510	0.8135	GTS-35	B 340/12	MN 35-10	-	
29		40010	0.8145	GTS-45	P 440/7	-	-	
29		50005	0.8155	GTS-55	P 510/4	MP50-5	-	
29		70003	0.8165	GTS-65	P 570/3	MP 60-3	-	
29		80002	0.8170	GTS-70	P690/2	MP 70-2	-	
N Non-Ferrous Metals		36	-	-	G-AISI12	LM20	-	-
	36	-	-	GD-AISI12	-	-	-	
	36	-	-	GD-AISI8Cu3	LM24	-	-	
	36	-	-	G-AISI10Mg	LM9	-	-	
	36	-	-	G-AISI12	LM6	-	-	
S Heat Resistant Material	19	330	1.4864	X12NiCrSi	-	Z12NCS35.16	-	
	19	-	1.4865	G-X40NiCrSi	330C11	-	XG50NiCr	
	19	5390 A	2.4603	-	-	NC22FeD	-	
	19	-	2.4630	NiCr20Ti	HR5, 203-4	NC20T	-	
	19	5666	2.4856	NiCr22Mo9N	-	NC22FeDNB	-	
	19	5537 C	LW2.496	CoCr20W15	-	KC20WN	-	
	19	4676	2.4375	NiCu30Al	3072-76	-	-	
	19	-	2.4631	NiCr20TiAk	HR40,601	NC20TA	-	
	19	AMS 5399	2.4973	NiCr19Co11	-	NC19KDT	-	
	21	5391	LW2.467	S-NiCr13Al6	3146-3	NC12AD	-	
	21	5660	LW2.466	NiCr19Fe19	HR8	NC19FeNb	-	
	21	5383	LW2.466	NiCr19Fe19	-	NC20K14	-	
	21	-	-	CoCr22W14	-	KC22WN	-	
	21	-	LW2.467	NiCo15Cr10	-	-	-	
	23	-	-	TiAl14Mo4Sn4Si0.5	-	-	-	
	23	-	-	TiAl5Sn2.5	TA14/17	T-A5E	-	
	23	-	-	TiAl6V4	TA10-13/TA2	T-A6V	-	
	23	-	-	TiAl6V4ELI	TA11	-	-	

Thread Turning
Technical Data

Sweden SS	Japan JIS	Russia GOST	Spain UNE	Vargus No.		
2301	SUS403	08Ch13	F.3110-X6Cr13 ; F.8401-AM-X12Cr13	12	M	
-	-	08Ch13	F.3110-X6Cr13 ; F.8401-AM-X12Cr13	12		
2302	SUS410	12Ch13 ; 15Ch13L	F.3401-X10Cr13	12		
2320	SUS430	12Ch17	F.3113-X6Cr17	12		
-	SCS2	20Ch13L	-	12		
2304	SUS420J2	40Ch13	F.3405-X45Cr13	12		
2321	SUS431	20Ch17N2	F.3427-X19CrNi172	12		
2383	SUS430F	-	F.3117-X10CrSi17 ; F.3413-X14CrMoSi7	12		
2325	SUS434	-	F.3116-X6CrMo171	12		
-	SCS5	-	-	12		
-	SCS14	07Ch18N10G2S2M2L	F.8414-AM-X7CrNiMo2010	12		
-	SUH1	40Ch9S2	F.3220-X45CrSi09-03	12		
-	SUS405	10Ch13SJu	F.3152-X10CrAl13	12		
-	SUH21	15Ch18SJu	F.3153-X10CrAl18	11		
-	SUH4	-	F.3222-X80CrSiNi20-02	12		
2322	SUH446	-	F.3154-X10CrAl24	11		
2332	SUS304	08Ch18N10	F.3551-X5CrNi1811; F.3541-X5CrNi1810 ; F.3504-X6CrNi1910	13		
2346	SUS303	-	F.3508-X10CrNiSi18-09	13		
2352	SCS19; SUS304L	03Ch18N11	F.3503-X2CrNi1810	13		
2333	SCS13	07Ch18N9L	-	13		
2331	SUS301	-	F.3517-X12CrNi177	13		
2371	SUS304LN	-	F.3541-X2CrNi1810	13		
2347	SUS316	-	F.3534-X5CrNiMo17122	13		
2375	SUS316LN	-	F.3543-X2CrNiMoN17133	13		
2353	SCS16	03Ch17N14M3	F.3533-X2CrNiMo17132	13		
2367	SUS317L	-	F.3539-X2CrNiMo18164	13		
2324	SUS329L;	-	F.3309-X8CrNiMo27-05; F.3552-X8CrNiMo266	13		
58B	SUS321	06Ch18N10T; 08Ch18N10T; 09Ch18N10T; 12Ch18N10T	F.3523-X6CrNiTi1810	12		
2338	SUS347	08Ch18N12B	F.3524-X6CrNiNb1810	12		
2350	-	10Ch17N13M2T	F.3535-X6CrNiMoTi17122	12		
-	SCS22	-	-	12		
-	-	-	-	12		
-	SUH309	20Ch20N14S2	F.3312-X15CrNiSi20-12	13		
2361	SUH310	20Ch23N18	-	13		
-	SUH330	-	F.3313-X12CrNiSi36-16	13		
-	SCH15	-	-	13		
-	SUH35;SUH36;SU321	55Ch20G9AN4	F.3217-X53CrMnNiN21-09	13		
-	-	-	-	13		
01 10	-	C410	FG10	30		K
01 15	-	C415	FG15	30		
01 20	-	C420	FG20	30		
01 25	-	C425	FG25	29		
01 30	-	C430	FG30	29		
01 35	-	C435	FG35	29		
01 40	-	C440	-	29		
MB	-	-	-	29		
ISO-215	-	-	-	29		
523	-	-	-	29		
07 17-02	-	VC42-12	-	30		
07 17-12	-	VC42-12	-	30		
07 17-15	-	-	-	30		
07 27-02	-	VC50-2	-	31		
07 32-03	-	VC60-2	-	31		
07 37-01	-	VC70-2	-	31		
07 72	-	-	-	31		
07 76	-	-	-	31		
-	-	-	-	31		
08 15	-	-	-	28		
08 52	-	-	-	29		
08 54	-	-	-	29		
08 58	-	-	-	29		
08 62	-	-	-	29		
4260	-	-	-	36		
4247	-	-	-	36		
4250	-	-	-	36		
4253	-	-	-	36		
4261	-	-	-	36		
-	SUH 330	-	F.3313-X12CrNiSi36-16	19	N	
-	SCH 15	-	-	19		
-	-	-	-	19		
-	-	-	-	19		
-	-	-	-	19		
-	-	-	-	19		
-	-	-	-	19		
-	-	-	-	19		
-	-	-	-	19		
-	-	-	-	19		
-	-	-	-	19		
-	-	-	-	19		
-	-	-	-	19		
-	-	-	-	19		
-	-	-	-	19		
-	-	-	-	19		
-	-	-	-	21	S	
-	-	-	-	21		
-	-	-	-	21		
-	-	-	-	21		
-	-	-	-	21		
-	-	-	-	21		
-	-	-	-	21		
-	-	-	-	21		
-	-	-	-	23		
-	-	-	-	23		
-	-	-	-	23		

Troubleshooting

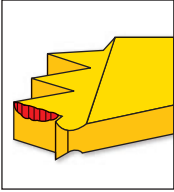
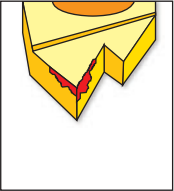
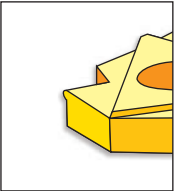
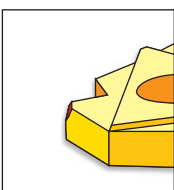
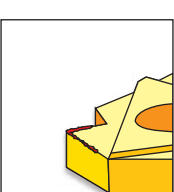
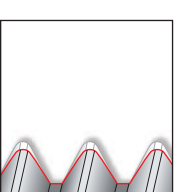
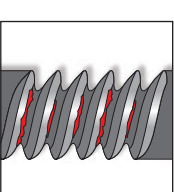
Problem	Possible Cause	Solution
 <p>Increased flank wear</p>	<ul style="list-style-type: none"> Cutting speed too high -----> Depth of cut too low/ too many passes -----> Unsuitable carbide grade -----> Insufficient cooling -----> 	<ul style="list-style-type: none"> Reduce cutting speed / use coated insert Increase the depth of cut per pass Use a coated carbide grade Increase coolant flow rate
 <p>Uneven cutting edge wear</p>	<ul style="list-style-type: none"> Incorrect helix angle -----> Wrong infeed method -----> 	<ul style="list-style-type: none"> Choose the correct anvil Use the alternating flank infeed method
 <p>Extreme plastic deformation</p>	<ul style="list-style-type: none"> Depth of cut too large -----> Insufficient cooling -----> Cutting speed too high -----> Unsuitable carbide grade -----> Nose radius too small -----> 	<ul style="list-style-type: none"> Decrease depth of cut/ increase number of passes Increase coolant flow rate Reduce cutting speed Use a tougher carbide Use an insert with a larger radius, if possible
 <p>Cutting edge breakage</p>	<ul style="list-style-type: none"> Depth of cut too large -----> Extreme plastic deformation -----> Insufficient cooling -----> Unsuitable carbide grade -----> Instability -----> 	<ul style="list-style-type: none"> Decrease depth of cut/ increase number of passes Use a tougher carbide Increase flow rate and/ or correct flow direction Use a tougher carbide Check stability of the system
 <p>Built-up edge</p>	<ul style="list-style-type: none"> Incorrect cutting speed -----> Unsuitable carbide grade -----> 	<ul style="list-style-type: none"> Change the cutting speed Use a coated carbide
 <p>Thread profile is too shallow</p>	<ul style="list-style-type: none"> The tool is not at the workpiece axis height ---> Insert is not machining the thread crest -----> Worn insert -----> 	<ul style="list-style-type: none"> Change tool height Measure the workpiece diameter Change the cutting edge sooner
 <p>Poor surface quality</p>	<ul style="list-style-type: none"> Cutting speed too low -----> Wrong anvil -----> Flank infeed method is not appropriate -----> 	<ul style="list-style-type: none"> Increase cutting speed Choose correct anvil Use the alternate flank or radial infeed method

VRX

Multipurpose Premium Grade

Multipurpose Thread Turning Grade for Stronger
Wear Resistance and Improved Productivity

Redefining the **Threading** Benchmark



AlTiN Alloyed PVD Coating

High Oxidation Temperature

Submicron Substrate

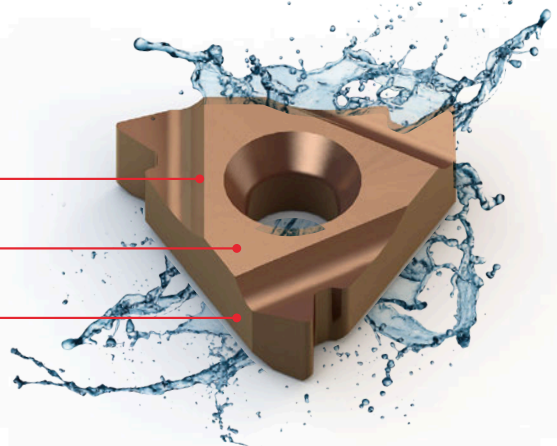

See page 202 for more information.

Thread Turning
Technical Data

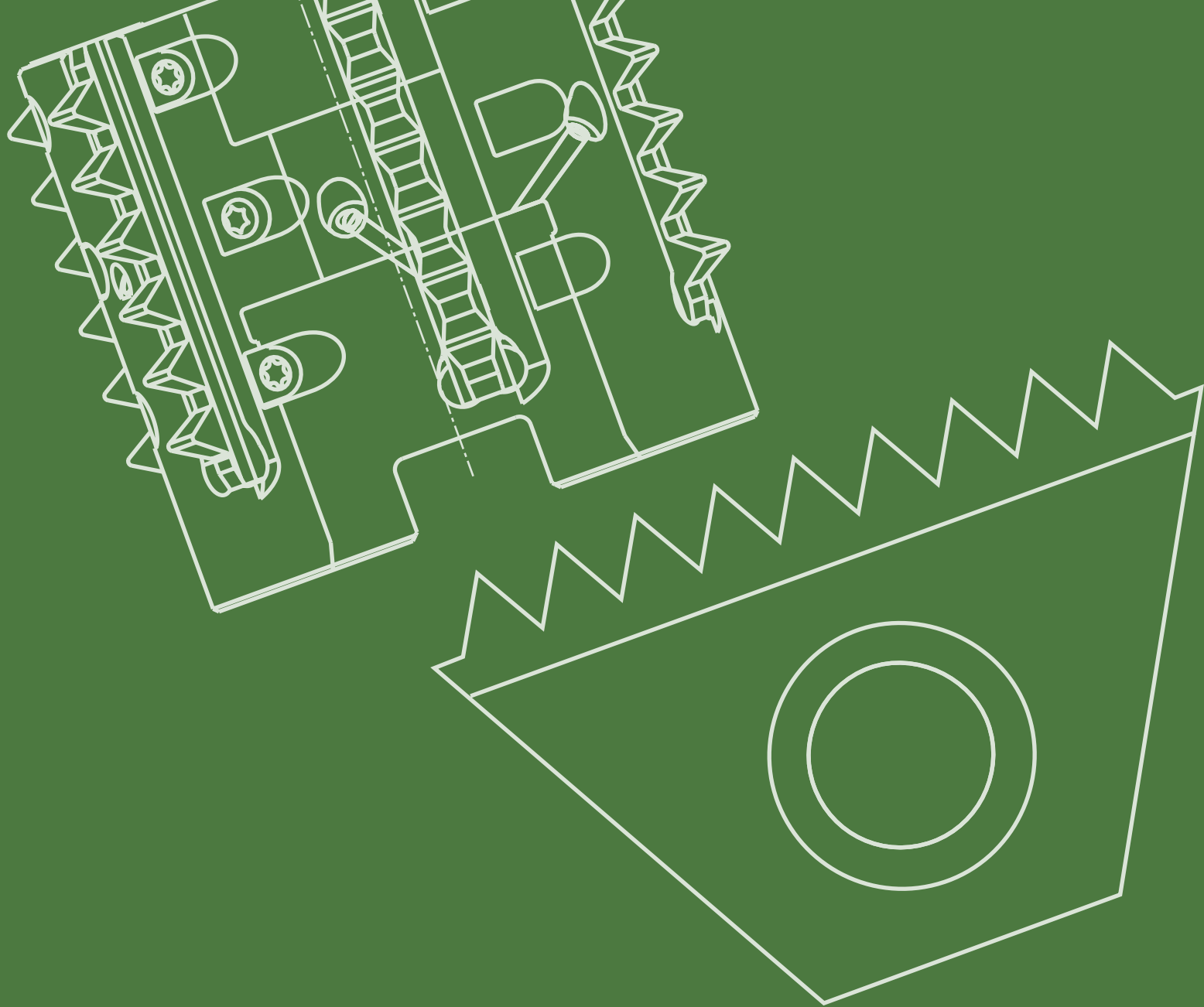

THREAD MILLING

■ MiTM	229
■ TM Standard	251
■ TMSD	293
■ TM Solid	329
■ Technical Data	367

Thread Milling Systems

MiTM Multi-Flute Indexable Thread Mill Inserts

MiTM19 (A) For Small Bores



MiTM24 (M) For Medium Bores



MiTM25 (S) For Standard Applications



MiTM40 (L) For Long Threads



MiTM41 (B) For Large Pitches



Standard

Standard / TMF

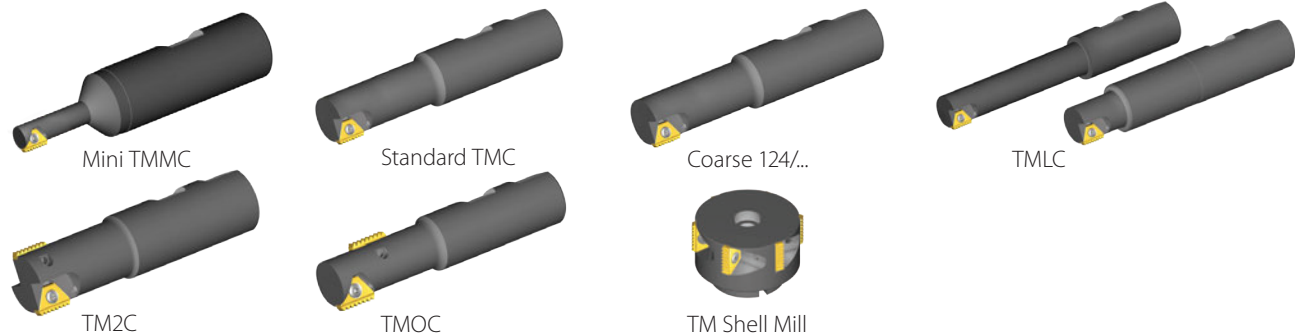

Coarse Pitch

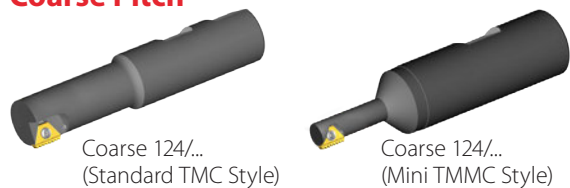

Conical

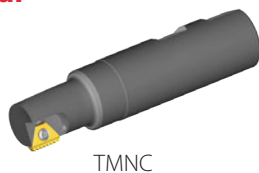

TMSC - Single Point



TMVC - Single Point Vertical

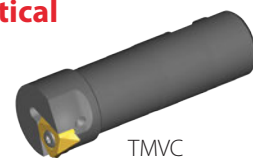

Thread Milling Systems

TMSD Thread Milling for Deep Holes

U Style For Large Pitches

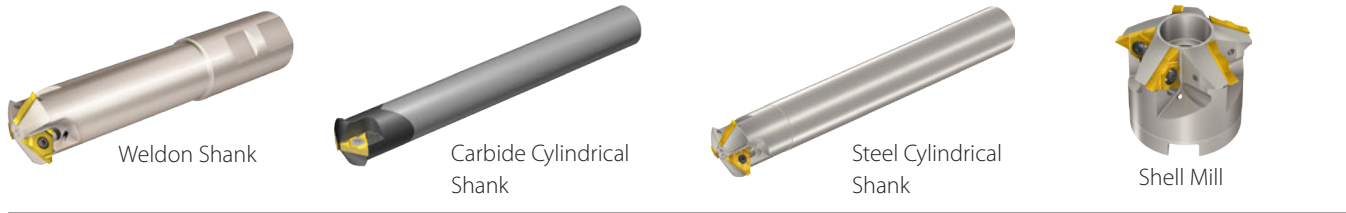

L Style (Mini L) For Small Bores and Short L2



Vertical Style (7V, 9V, 11V)



L Style (3/8" L) For Large Trapezoid Profiles and ABUT



A Style For Shorter L2



TM Solid Solid Carbide Thread Milling Tools

Helical Flutes with Coolant



Helical Flutes



Miniature Tools



Straight Flutes



Long Tools

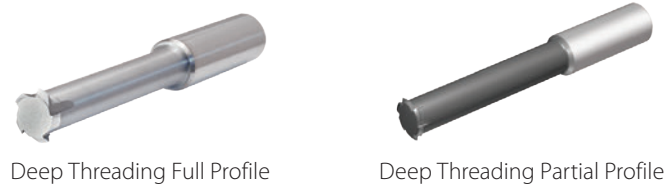

Thread Milling Methods

(for RH Tools only)

External

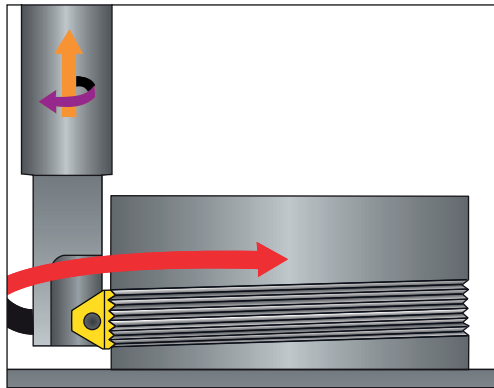

Right Hand Thread - Conventional Milling

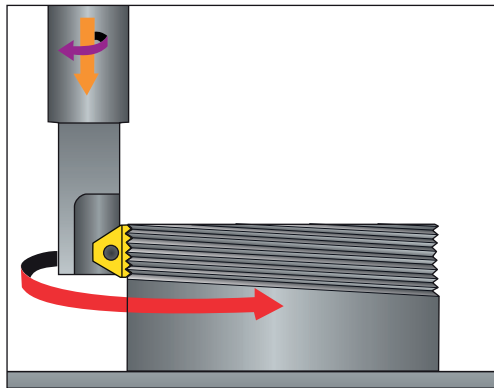

Left Hand Thread - Conventional Milling

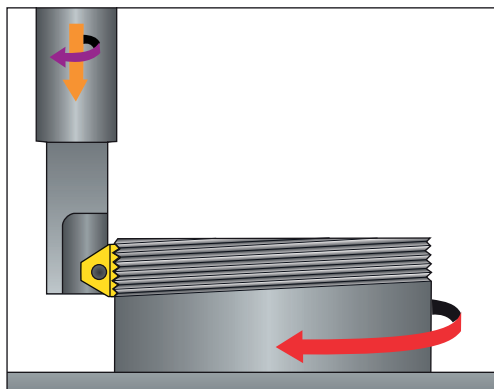

Right Hand Thread - Climb Milling

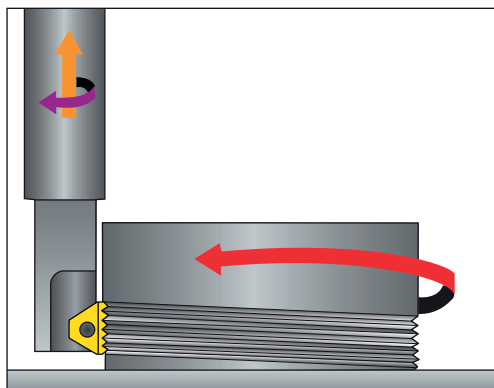

Left Hand Thread - Climb Milling

Internal

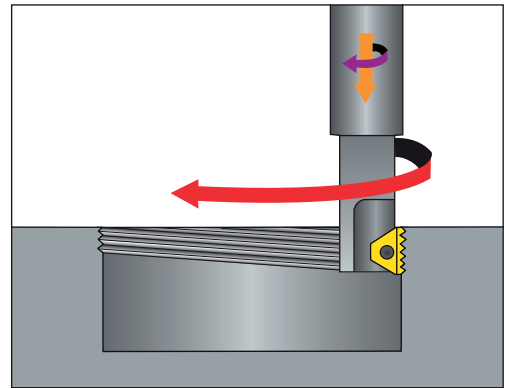

Right Hand Thread - Conventional Milling

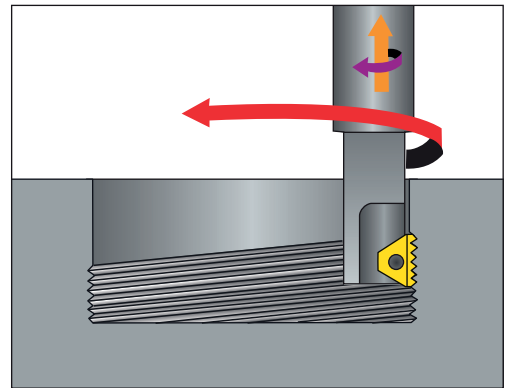

Left Hand Thread - Conventional Milling

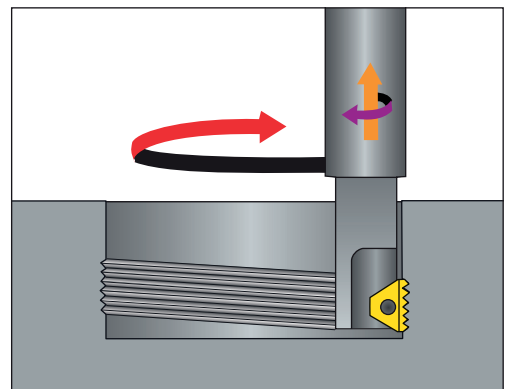

Right Hand Thread - Climb Milling

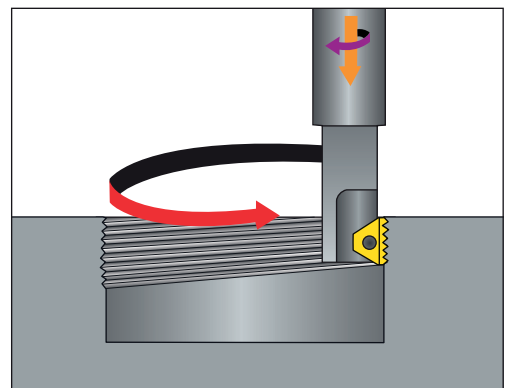

Left Hand Thread - Climb Milling

The Thread Milling Advantages

- Enables machining of large work pieces which cannot be easily mounted on a lathe
- Easily machine non-rotatable and asymmetrical parts
- Complete operation in one clamping
- Threading of large diameters requires less power than threading using taps
- No upper limits to bore diameter
- Chips are short
- Blind holes without a thread relief groove can be machined
- Thread relief grooves are unnecessary
- One holder can be used for both internal and external threads
- One tool can be used for both right hand and left hand thread
- Inventory can be reduced to a minimum as small range of tooling covers a wide range of thread diameters
- Interchangeable inserts
- Suitable for machining of hard materials
- Threads have a high surface finish
- Allows for correction of tool diameter and length
- Interrupted cuts are easily machined
- One tool for a wide range of materials
- A better thread quality in soft materials where taps normally tear the material
- Short machining time due to high cutting speed and rapid feed rates
- Small cutting forces allow machining of parts with thin walls

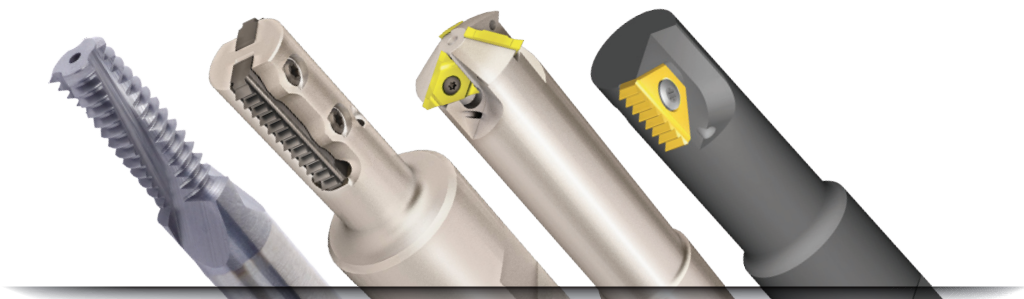



MiTM

Super Fast Thread Milling System

Inserts | Toolholders

Vardex Ordering Code System

MiTM Inserts

R 1	25 2	I 3	12 4	UN 5	TM 6	VBX 7	
1 - Product Line R - MiTM line	2 - Insert Style 19, 24, 25, 40, 41	3 - Type of Insert I - Internal E - External EI-External+Internal NC- Plug		4 - Pitch 0.5-6.0 mm 32-4 TPI	5 - Standard ISO- ISO Metric UN-American UN W- BSW, BSP NPT-NPT NPTF-NPTF BSPT-BSPT	6 - System TM	7 - Carbide Grade VBX VTX

MiTM Holders (Standard and Conical)

R 1	TM 2	C 3	100 4	067 5	-	110 6	S 7	2 8
1 - Product Line R - MiTM line BR - MiTM with Anti-vibration System	2 - Holder Type TM - Standard Holder TMN - Conical Holder	3 - Cooling C - Coolant Channel	4 - Shank Dia. .75, 1, 1.25	5 - Cutting Dia. .54-1.42				
6 - Tool Overhang 1.02-3.15	7 - Insert Style A - 19 M - 24 S - 25 L - 40 B - 41	8 - No. of Flutes 1 - 5						

MiTM Shell Mill

R 1	TM 2	C 3	-	D150 4	-	050 5	-	25S 6	5 7
1 - Product Line R - MiTM line	2 - Holder Type TM - Standard Holder TMN - Conical Holder	3 - Cooling C - Coolant Channel	4 - Cutting Dia. 1.54-2.48	5 - Drive Hole Dia. .50, .75, 1.00					
6 - Insert Style 25S 40L 41B	7 - No. of Flutes 5 - 8								

MiTM

The VARDEX Multi-flute Indexable Thread Milling (MiTM) system for fast machining, reduces cycle times when machining threads with long inserts. Nickel coating for all MiTM toolholders provides better anti-rust protection.

MiTM 19 (A) For Small Bores



Standard
No. of Flutes (Z) 1
Cutting Dia. (D2) .39-.46
Tool Overhang (L1) .79-.99



Conical
No. of Flutes (Z) 1
Cutting Dia. (D2) .42
Tool Overhang (L1) .71

MiTM 24 (M) For Medium Bores



Standard
No. of Flutes (Z) 1-2
Cutting Dia. (D2) .53-.63
Tool Overhang (L1) 1.02-1.42



Conical
No. of Flutes (Z) 1
Cutting Dia. (D2) .55
Tool Overhang (L1) 1.02

MiTM 25 (S) For Standard Applications



Standard
No. of Flutes (Z) 2-5
Cutting Dia. (D2) .67-1.18
Tool Overhang (L1) 1.10-3.15



Conical
No. of Flutes (Z) 2-4
Cutting Dia. (D2) .68-1.12
Tool Overhang (L1) 1.10-1.70

MiTM 40 (L) For Long Threads



Standard
No. of Flutes (Z) 3-4
Cutting Dia. (D2) .87-1.18
Tool Overhang (L1) 1.69-3.15

MiTM 41 (B) For Large Pitches



Standard
No. of Flutes (Z) 1-5
Cutting Dia. (D2) .84-1.42
Tool Overhang (L1) 1.69-2.56



Shell Mill
No. of Flutes (Z) 5-9
Cutting Dia. (D2) 1.54-2.32
Tool Overhang (L1) max. 7.87



Shell Mill Conical
No. of Flutes (Z) 5
Cutting Dia. (D2) 1.53
Tool Overhang (L1) max. 7.87



Shell Mill
No. of Flutes (Z) 7-9
Cutting Dia. (D2) 1.93-2.32
Tool Overhang (L1) max. 7.87



Shell Mill Conical
No. of Flutes (Z) 7
Cutting Dia. (D2) 1.93
Tool Overhang (L1) max. 7.87



Shell Mill
No. of Flutes (Z) 5-6
Cutting Dia. (D2) 2.09-2.48
Tool Overhang (L1) max. 7.87



ISO Metric

External / Internal

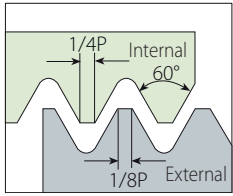

Defined by: R262 (DIN 13)
Tolerance class: 6g/6H

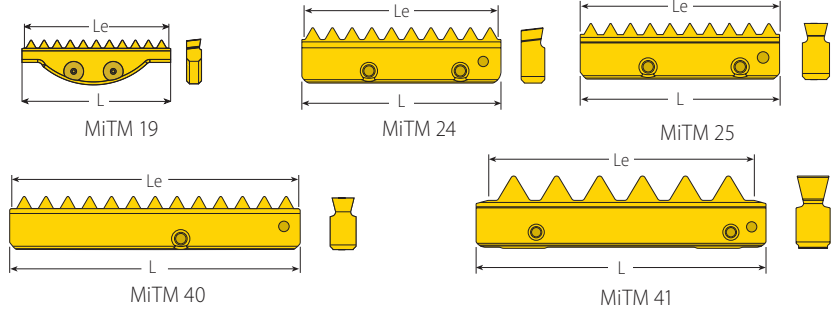

Standard MiTM

Insert Style	Pitch	Ordering Code	EDP No.	Ordering Code	EDP No.	Cutting Edge	Teeth	Toolholder		
L	mm	External		Internal	VTX	VBX	Le	Zt		
19	0.5			R19I0.50ISOTM...	81001	81000	1	.79	40	
	0.75			R19I0.75ISOTM...	81003	81002	1	.79	27	
	1.0			R19I1.00ISOTM...	81005	81004	1	.79	20	
	1.25			R19I1.25ISOTM...	81007	81006	1	.79	16	RTMC...A
	1.5			R19I1.50ISOTM...	81009	81008	1	.77	13	
	1.75			R19I1.75ISOTM...	81011	81010	1	.76	11	
24	2.0			R19I2.00ISOTM...	81013	81012	1	.79	10	
	0.5			R24I0.50ISOTM...	80753	80754	1	.96	49	
	0.75			R24I0.75ISOTM...	80755	80751	1	.97	33	
	1.0			R24I1.00ISOTM...	80756	80757	1	.94	24	
	1.25			R24I1.25ISOTM...	80758	80759	1	.98	20	RTMC...M
	1.5			R24I1.50ISOTM...	80760	80761	1	.94	16	
25	1.75			R24I1.75ISOTM...	80762	80763	1	.96	14	
	2.0			R24I2.00ISOTM...	80764	80765	1	.94	12	
	2.5			R24I2.50ISOTM...	80766	80767	1	.98	10	
	1.0	R25E1.00ISOTM...	80584	80585	R25I1.00ISOTM...	80482	80483	2	.94	24
	1.25	R25E1.25ISOTM...	81046	81047	R25I1.25ISOTM...	81048	81049	2	.93	19
	1.5	R25E1.50ISOTM...	80586	80587	R25I1.50ISOTM...	80484	80485	2	.94	16
40	2.0	R25E2.00ISOTM...	80588	80589	R25I2.00ISOTM...	80486	80487	2	.94	12
	2.5	R25E2.50ISOTM...	80590	80591	R25I2.50ISOTM...	80488	80489	2	.98	10
	3.0	*R25E3.00ISOTM...	80592	80593	*R25I3.00ISOTM...	80490	80491	2	.94	8
	1.0			R40I1.00ISOTM...	80702	80703	2	1.54	39	
	1.5			R40I1.50ISOTM...	80704	80705	2	1.54	26	
	2.0			R40I2.00ISOTM...	80706	80707	2	1.50	19	(B)RTMC...L
41	2.5			R40I2.50ISOTM...	80708	80709	2	1.48	15	
	3.0			R40I3.00ISOTM...	80710	80711	2	1.54	13	
	3.0	R41E3.00ISOTM...	80768	80769	R41I3.00ISOTM...	80782	80783	2	1.54	13
	3.5	R41E3.50ISOTM...	80770	80771	R41I3.50ISOTM...	80784	80785	2	1.52	11
	4.0	R41E4.00ISOTM...	80772	80773	R41I4.00ISOTM...	80786	80787	2	1.57	10
	4.5	R41E4.50ISOTM...	80774	80775	R41I4.50ISOTM...	80788	80789	2	1.59	9
41	5.0	R41E5.00ISOTM...	80776	80777	R41I5.00ISOTM...	80790	80791	2	1.57	8
	5.5	R41E5.50ISOTM...	80778	80779	R41I5.50ISOTM...	80792	80793	2	1.52	7
	6.0	R41E6.00ISOTM...	80780	80781	R41I6.00ISOTM...	80794	80795	2	1.42	6

* 3.0 ISO inserts do not fit into toolholder RTMC100067...
For external insert 3.0 ISO use for CNC program (D2 + .02").

MiTM inserts 25, 40 and 41 are offered with 2 cutting edges. In case of chip flow difficulty, inserts with a single cutting edge can be ordered by request. Example: R25I2.00ISOTM(S)...



American UN - UNC, UNF, UNEF, UNS

External / Internal

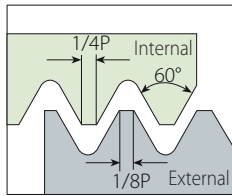

Defined by: ANSI B1.1:74
Tolerance class: 2A/2B

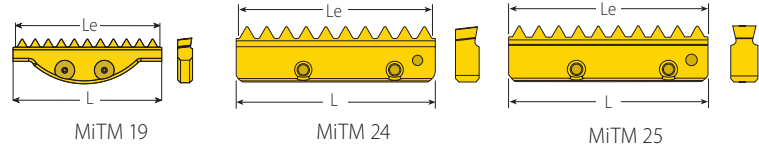

Standard MiTM



Insert Style	Pitch	Ordering Code	EDP No.		Ordering Code	EDP No.		Cutting Edge	Teeth	Toolholder	
			VTX	VBX		VTX	VBX				
L	TPI	External	VTX	VBX	Internal	VTX	VBX	Le	Zt		
19	32				R19I32UNTM...	81015	81014	1	.78	25	RTMC...A
	28				R19I28UNTM...	81017	81016	1	.79	22	
	27				R19I27UNTM...	81019	81018	1	.78	21	
	24				R19I24UNTM...	81021	81020	1	.79	19	
	20				R19I20UNTM...	81023	81022	1	.75	15	
	18				R19I18UNTM...	81025	81024	1	.78	14	
	16				R19I16UNTM...	81027	81026	1	.75	12	
	14				R19I14UNTM...	81029	81028	1	.79	11	
	13				R19I13UNTM...	81031	81030	1	.77	10	
24	32				R24I32UNTM...	80796	80797	1	.97	31	RTMC...M
	28				R24I28UNTM...	80798	80799	1	.96	27	
	24				R24I24UNTM...	80802	80803	1	.96	23	
	20				R24I20UNTM...	80804	80805	1	.95	19	
	18				R24I18UNTM...	80806	80807	1	.94	17	
	16				R24I16UNTM...	80808	80809	1	.94	15	
	14				R24I14UNTM...	80810	80811	1	.93	13	
	12				R24I12UNTM...	80812	80813	1	.92	11	
	10				R24I10UNTM...	80814	80815	1	.90	9	
25	20	R25E20UNTM...	80594	80595	R25I20UNTM...	80492	80493	2	.95	19	(B)RTMC...S
	18	R25E18UNTM...	80596	80597	R25I18UNTM...	80494	80495	2	.94	17	
	16	R25E16UNTM...	80598	80599	R25I16UNTM...	80496	80497	2	.94	15	
	14	R25E14UNTM...	80600	80601	R25I14UNTM...	80498	80499	2	.93	13	
	12	R25E12UNTM...	80602	80603	R25I12UNTM...	80500	80501	2	.92	11	
	10	R25E10UNTM...	80604	80605	R25I10UNTM...	80502	80503	2	.90	9	
	9	*R25E9UNTM...	80606	80607	*R25I9UNTM...	80504	80505	2	.89	8	
	8	*R25E8UNTM...	80608	80609	*R25I8UNTM...	80506	80507	2	.87	7	

* Note: 8 UN & 9 UN inserts do not fit into toolholder RTMC100067...
For external insert 8 UN use for CNC program (D2 + .02").

MiTM inserts 25, 40 and 41 are offered with 2 cutting edges. In case of chip flow difficulty, inserts with a single cutting edge can be ordered by request. Example: R25I20UNTM(S)...



American UN - UNC, UNF, UNEF, UNS (con't)

External / Internal

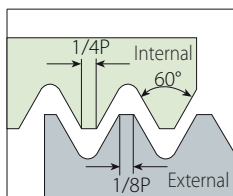

Defined by: ANSI B1.1:74
Tolerance class: 2A/2B

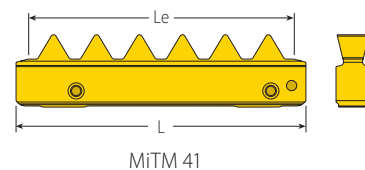
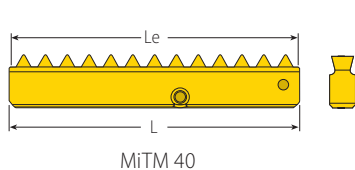

MITM

Standard MiTM



Insert Style	Pitch	Ordering Code	EDP No.		Ordering Code	EDP No.		Cutting Edge	Teeth	Toolholder
L	TPI	External	VTX	VBX	Internal	VTX	VBX	Le	Zt	
40	20				R40I20UNTM...	80712	80713	2	1.55	31
	18				R40I18UNTM...	80714	80715	2	1.56	28
	16				R40I16UNTM...	80716	80717	2	1.56	25
	14				R40I14UNTM...	80718	80719	2	1.57	22
	12				R40I12UNTM...	80720	80721	2	1.50	18
	10				R40I10UNTM...	80722	80723	2	1.50	15
	9				R40I9UNTM...	80724	80725	2	1.56	14
41	8				R40I8UNTM...	80726	80727	2	1.50	12
	8	R41E8UNTM...	80816	80817	R41I8UNTM...	80828	80829	2	1.50	12
	7	R41E7UNTM...	80818	80819	R41I7UNTM...	80830	80831	2	1.57	11
	6	R41E6UNTM...	80820	80821	R41I6UNTM...	80832	80833	2	1.50	9
	5	R41E5UNTM...	80822	80823	R41I5UNTM...	80834	80835	2	1.40	7
	4.5	R41E4.5UNTM...	80824	80825	R41I4.5UNTM...	80836	80837	2	1.56	7
	4	R41E4UNTM...	80826	80827	R41I4UNTM...	80838	80839	2	1.50	6

(B)RTMC...L
RTMC...B

MiTM inserts 25, 40 and 41 are offered with 2 cutting edges. In case of chip flow difficulty, inserts with a single cutting edge can be ordered by request. Example: R25I20UNTM(S)...



Whitworth for BSF, BSP (G)

External / Internal

Defined by: B.S.84:1956, DIN 259, DIN ISO228/1:1982
Tolerance class: Medium Class A

Standard MiTM

Insert Style	Pitch	Ordering Code	EDP No.		Ordering Code			Cutting Edge	Teeth	Toolholder		
			VTX	VBX	Internal	VTX	VBX					
19	L	TPI	External+Internal	VTX	VBX	Internal	VTX	VBX	Le	Zt		
	19	16	R19EI19WTM...	81035	81034				1	.79	15	
	19	16	R19EI16WTM...	81037	81036				1	.75	12	RTMC...A
24	19	14	R19EI14WTM...	81039	81038				1	.79	11	
	24	19	R24EI19WTM...	80844	80845				1	.95	18	
	24	14	R24EI14WTM...	80846	80847				1	.93	13	RTMC...M
25	12	12	R24EI12WTM...	80848	80849				1	.92	11	
	25	16	R25EI16WTM...	80508	80509				2	.94	15	
	25	14	R25EI14WTM...	80510	80511				2	.93	13	(B)RTMC...S
40	12	12	R25EI12WTM...	80512	80513				2	.92	11	
	40	16	R40EI16WTM...	80610	80611				2	1.56	25	
	40	14	R40EI14WTM...	80612	80613				2	1.57	22	(B)RTMC...L
41	12	12	R40EI12WTM...	80614	80615				2	1.50	18	
	41	11	R40EI11WTM...	80616	80617				2	1.55	17	
	41	8				R41I8WTM...	80850	80851	2	1.50	12	
		7				R41I7WTM...	80852	80853	2	1.57	11	RTMC...B
		6				R41I6WTM...	80854	80855	2	1.50	9	

MiTM inserts 25, 40 and 41 are offered with 2 cutting edges. In case of chip flow difficulty, inserts with a single cutting edge can be ordered by request. Example: R25EI16WTM(S)...



NPT

External / Internal

Defined by: USAS B2.1:1968
Tolerance class: Standard NPT

MITM

Standard MiTM

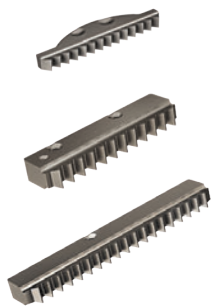

Insert Style	Pitch	Ordering Code	EDP No.		Cutting Edge	Teeth	Toolholder	
L	TPI	External+Internal	VTX	VBX	Le	Zt		
19	18	R19EI18NPT-TM...	81041	81040	1	.78	14	RTMNC...A
24	18	R24EI18NPT-TM...	80873	80874	1	.94	17	RTMNC...M
25	14	R25EI14NPT-TM...	80516	80517	1	.93	13	RTMNC...S
	11.5	R25EI11.5NPT-TM...	80518	80519	1	.96	11	
40	8	R25EI8NPT-TM...	80580	80581	1	.87	7	RTMNC-D150-050-25S5
	11.5	R40EI11.5NPT-TM...	80743	80744	1	1.48	17	RTMNC-D190-075-40L7
41	8	R40EI8NPT-TM...	80728	80729	1	1.50	12	
	8	R41EI8NPT-TM...	80840	80841	1	1.50	12	RTMC...B

NPTF

External / Internal

Defined by: ANSI B1.20.3-1976
Tolerance class: Standard NPTF

Standard MiTM



Insert Style	Pitch	Ordering Code	EDP No.		Cutting Edge	Teeth	Toolholder	
L	TPI	External+Internal	VTX	VBX	Le	Zt		
19	18	R19EI18NPTFTM...	81043	81042	1	.78	14	RTMNC...A
24	18	R24EI18NPTFTM...	80875	80876	1	.94	17	RTMNC...M
25	14	R25EI14NPTFTM...	80520	80521	1	.93	13	RTMNC...S
	11.5	R25EI11.5NPTFTM...	80522	80523	1	.96	11	
40	8	R25EI8NPTFTM...	80582	80583	1	.87	7	RTMNC-D150-050-25S5
	11.5	R40EI11.5NPTFTM...	80745	80746	1	1.48	17	RTMNC-D190-075-40L7
	8	R40EI8NPTFTM...	80730	80731	1	1.50	12	
41	8	R41EI8NPTFTM...	80842	80843	1	1.50	12	RTMC...B

BSPT

External / Internal

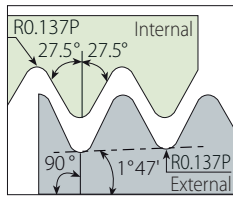

Defined by: B.S. 21:1985
Tolerance class: Standard BSPT

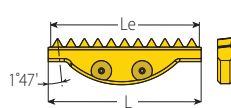

MiTM 19

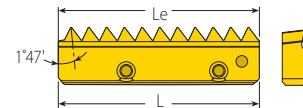

MiTM 24

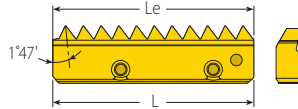

MiTM 25

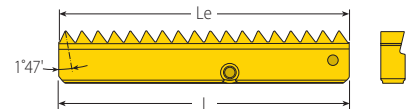

MiTM 40

Standard MiTM

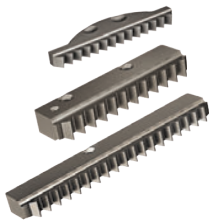

Insert Style	Pitch	Ordering Code	EDP No.		Cutting Edge	Teeth		Toolholder
L	TPI	External+Internal	VTX	VBX		Le	Zt	
19	19	R19EI19BSPT-TM...	81045	81044	1	.79	15	RTMNC...A
24	19	R24EI19BSPT-TM...	80871	80872	1	.95	18	RTMNC 075055-102M1
25	14	R25EI14BSPT-TM...	80524	80525	1	.93	13	RTMNC...S
	11	R25EI11BSPT-TM...	80526	80527	1	.91	10	
40	11	R40EI11BSPT-TM...	80732	80733	1	1.55	17	RTMNC-D190-075-40L7

Plug Insert



Insert Style	Ordering Code	EDP No.	Teeth	Toolholder
L	External+Internal		Zt	
24	R24NC	80858		RTMC...M
25	R25NC	80532	No Teeth	(B)RTMC...S RTMNC...S
40	R40NC	80626		(B)RTMC...L RTMNC...L
41	R41NC	80859		RTMC...B

Fill unused toolholder pockets with plug inserts (R..NC).
This assures balance and prevents instability and chips from packing into empty pockets.

MiTM

Standard Toolholders (MiTM 19)

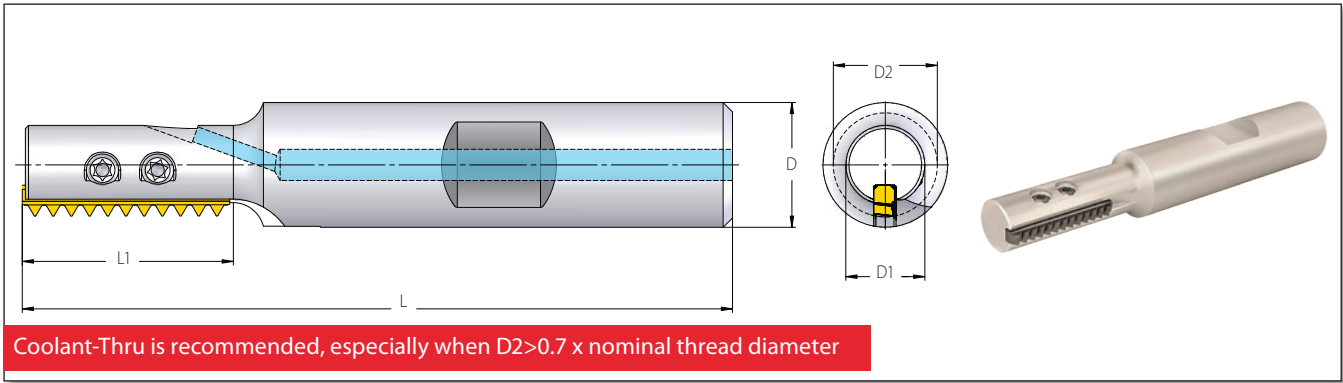

MITM

RTMC - for Standard Threads

Insert Style	Ordering Code	EDP No.	Dimensions Inch					No. of Flutes	Spare Parts	
			L	L1	D	D1	D2		Z	Location Screw x2
19	RTMC050039-079A1	80643	2.69	.79	.50	.30	.39	1	SLD3IP6 (M3x0.5) (80654)	<ul style="list-style-type: none"> • Use the included Vardex Torx+ screwdriver only. • Recommended max. torque 1.2 NxM (80656)
	RTMC050046-098A1	80646	2.91	.99	.50	.34	.46	1		

Standard Thread Application by Toolholder

Toolholder	Min. Thread Dia.						
	D2 (Inch)	ISO (coarse)	ISO (fine)	UNC	UN/UNF/UNEF/UNS	BSF	BSP(G)
RTMC050039-079A1	.39	M12x1.75	M11x0.5; M11x0.75; M11.5x1; M12x1.25; M12x1.5	1/2-13	7/16-32UN; 7/16-28UNEF; 7/16-27UNS; 1/2-24UNS; 1/2-20UNF; 1/2-18UNS; 1/2-16UN; 1/2-14UNS	1/2-16	1/4-19
RTMC050046-098A1	.46	M14x2.0; M16x2.0	M12.5x0.5; M13x0.75; M13x1; M13.5x1.25; M14x1.5; M14x1.75	5/16-12	1/2-32UN; 5/16-28UNS; 5/16-27UNS; 5/16-24UNEF; 5/16-20UN; 5/16-18UNF; 5/16-16UN; 5/16-14UNS;	5/16-14	1/4-14

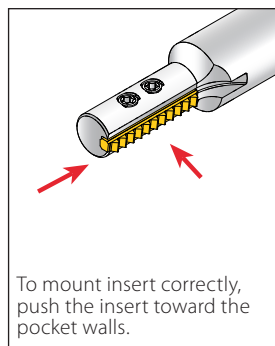
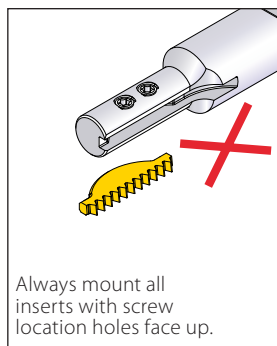
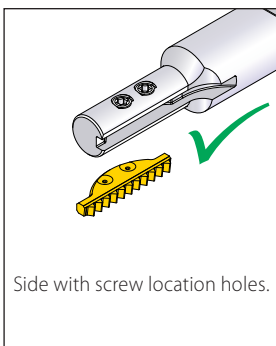

2 Step Clamping System

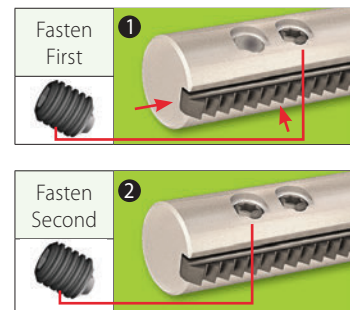

Conical Toolholders (MiTM 19)

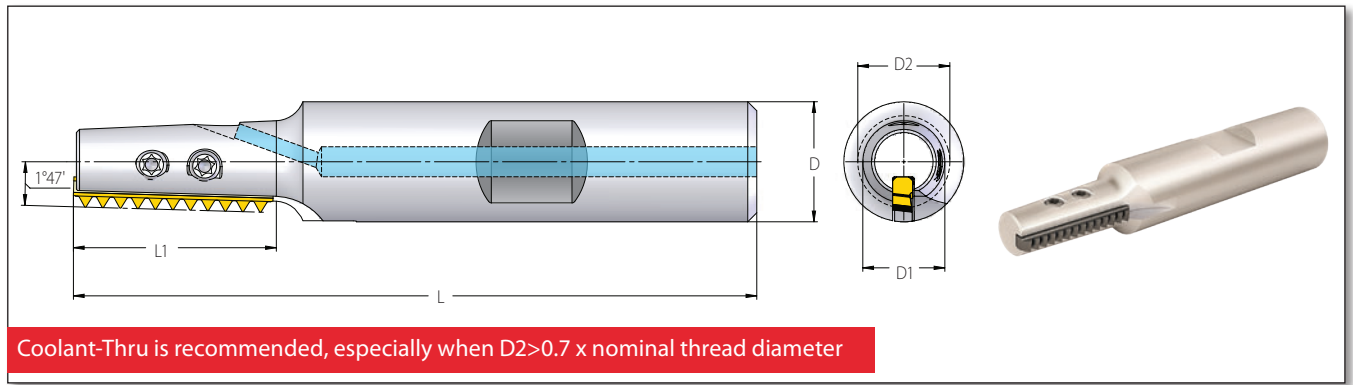

RTMNC - for Conical Threads

Insert Style	Ordering Code	EDP No.	Dimensions Inch					No. of Flutes	Spare Parts	
			L	L1	D	D1	D2		Z	Location Screw x2
19	RTMNC050039-074A1	80653	2.63	.71	.50	.32	.42	1	SLD3IP6 (M3x0.5) (80654)	<ul style="list-style-type: none"> • Use the included Vardex Torx+ screwdriver only. • Recommended max. torque 1.2 NxM (80656)

Conical Thread Application by Toolholder

Toolholder	D2 (Inch)	NPT	NPTF	BSPT
		RTMNC050039-074A1	.42	1/4-18* 3/8-18

* Using MiTM 19 tools the maximum thread length is .413"

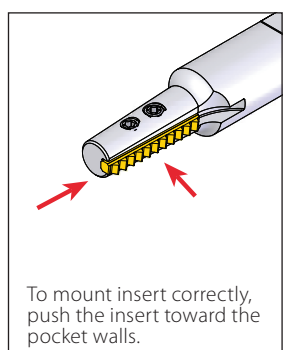
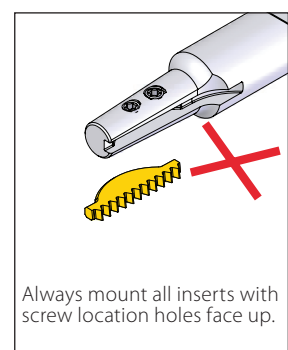
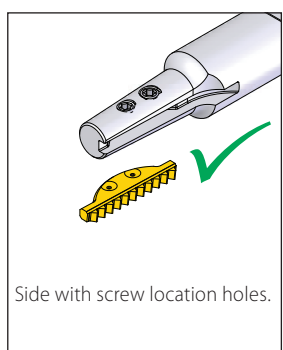

2 Step Clamping System

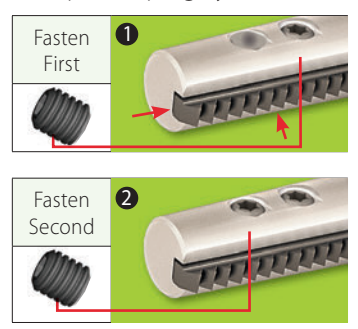

Standard Toolholders (MiTM 24)

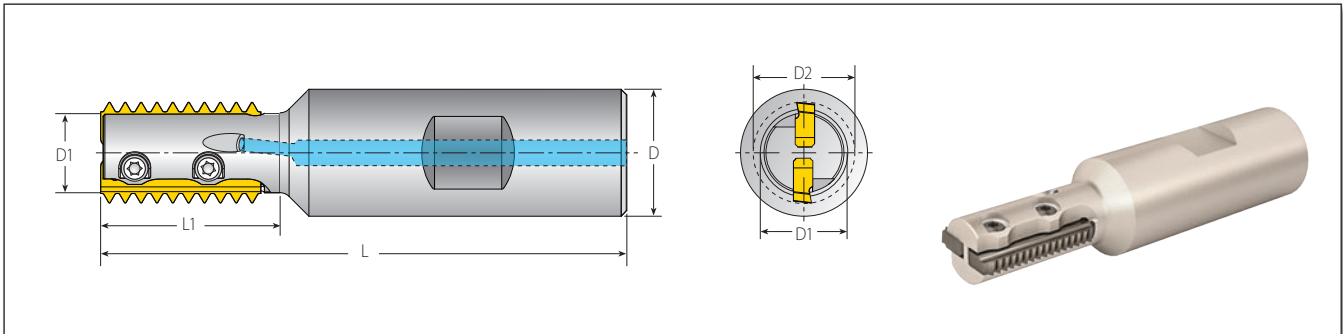

Coolant-Thru is recommended, especially when $D2 > 0.7 \times$ nominal thread diameter

MITM

RTMC - for Standard Threads

Spare Parts

Insert Style	Ordering Code	EDP No.	Dimensions Inch						No. of Flutes		
			L	L1	D	D1	D2	Z			
24	RTMC075053-102M1	80860	3.27	1.02	.75	.42	.53	1	SLD4IP8 (M4x0.7) (80533)	Torx+ Screwdriver	
	RTMC075059-118M1	80861	3.39	1.18	.75	.47	.59	1			
	RTMC075063-110M2	80752	3.31	1.10	.75	.49	.63	2			
	RTMC075063-142M1	80862	3.62	1.42	.75	.49	.63	1			

Standard Thread Application by Toolholder

Toolholder	Min. Thread Dia.						
	D2 (Inch)	ISO (coarse)	ISO (fine)	UNC	UN/UNF/UNEF/UNS	BSF	BSP(G)
RTMC075053-102M1	.53	M16x2	M14.5x0.5; M15x0.75; M15x1; M15x1.25; M16x1.5; M16x1.75	-	1/16-12UN; 5/8-14UNS; 5/8-16UN; 5/8-18UNF; 3/8-20UN; 3/8-24UNEF; 3/8-28UN; 3/8-32UN	1/16-14; 3/4-12	3/8-19; 1/2-14
RTMC075059-118M1	.59	M18x2.5	M16x0.5; M17x0.75; M17x1; M17x1.25; M17x1.5; M18x1.75; M18x2	3/4-10	3/4-12UN; 3/4-14UNS; 1/16-16UN; 1/16-20UN; 1/16-24UNEF; 1/16-28UN; 1/16-32UN	3/4-12	1/2-14
RTMC075063-110M2	.63	M20x2.5	M17x0.5; M17x0.75; M18x1; M18x1.25; M18x1.5; M18x1.75; M19x2	3/4-10	3/4-12UN; 3/4-14UNS; 3/4-16UN; 3/4-18UNS; 3/4-20UNEF; 1/16-24UNEF; 1/16-28UN; 1/16-32UN	3/4-12	1/2-14
RTMC075063-142M1	.63	M20x2.5	M17x0.5; M17x0.75; M18x1; M18x1.25; M18x1.5; M18x1.75; M19x2	3/4-10	3/4-12UN; 3/4-14UNS; 3/4-16UN; 3/4-18UNS; 3/4-20UNEF; 1/16-24UNEF; 1/16-28UN; 1/16-32UN	3/4-12	1/2-14

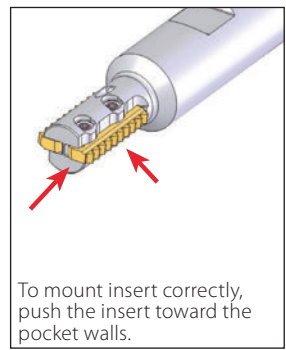
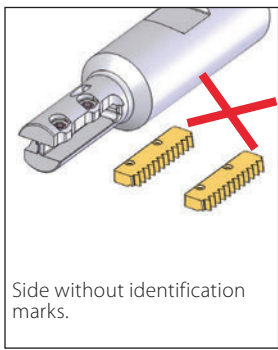
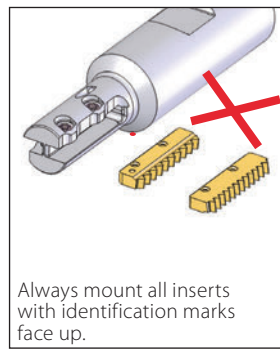
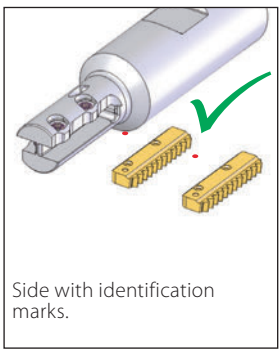

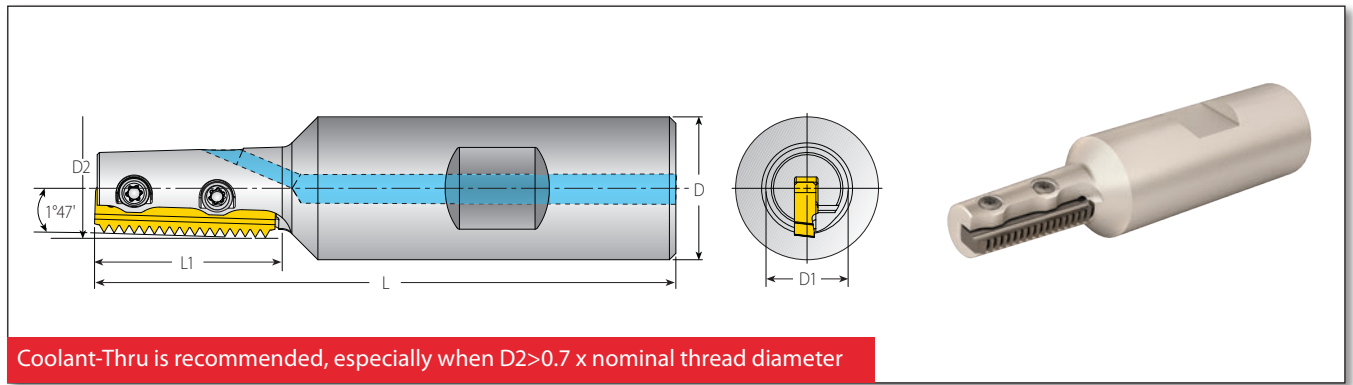

Conical Toolholders (MiTM 24)



Coolant-Thru is recommended, especially when $D2 > 0.7 \times$ nominal thread diameter

RTMC - for Conical Threads

Insert Style	Ordering Code	EDP No.	Dimensions Inch						No. of Flutes	Spare Parts	
			L	L1	D	D1	D2	Z			
24	RTMNC075055-102M1	80863	3.23	1.02	.75	.45	.55	1	SLD4IP8 (M4x0.7) (80533)	KIP8 •Use the included Vardex Torx+ screwdriver only. •Recommended max. torque 1.2 Nm (70231)	

Conical Thread Application by Toolholder

Toolholder	D2 (Inch)	Thread Dia.		
		NPT	NPTF	BSPT
RTMNC075055-102M1	.55	3/8-18	3/8-18	3/8-19

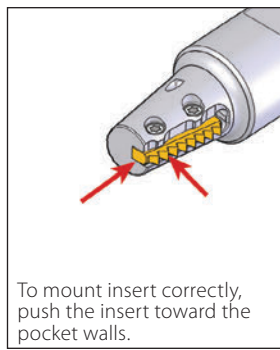
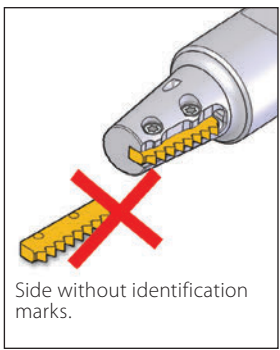
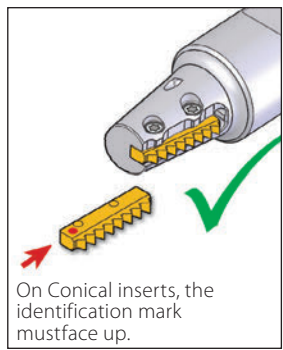

MiTM

Standard Toolholders (MiTM 25)

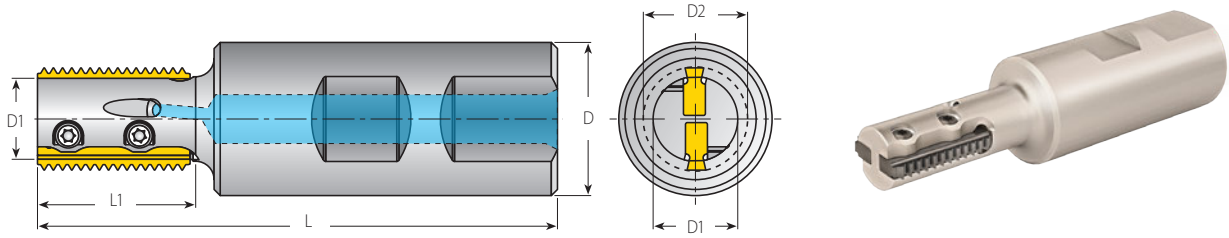

Coolant-Thru is recommended, especially when $D2 > 0.7 \times$ nominal thread diameter

RTMC - for Standard Threads

Spare Parts

Insert Style	Ordering Code	EDP No.	Dimensions Inch						No. of Flutes	Location Screw x2	Torx+ Screwdriver
			L	L1	D	D1	D2	Z			
25	RTMC075067-110S2	80748	3.29	1.10	.75	.55	.67	2	SLD4IP8 (M4x0.7) (80533)	KIP8 • Use the included Vardex Torx+ screwdriver only. • Recommended max. torque 1.2 NxM (70231)	
	RTMC075067-145S2	80747	3.65	1.45							
	RTMC100067-110S2	80471	3.50	1.10							
	RTMC100067-145S2	80472	3.86	1.45							
	RTMC100075-125S2	80633	3.65	1.25	1.00	.60	.75	2			
	RTMC100075-175S2	80634	4.15	1.75							
	RTMC100081-150S3	80474	3.90	1.50							
	RTMC100081-175S3	80475	4.15	1.75							
	RTMC100087-170S3	80476	4.09	1.70							
	RTMC100087-220S3	80478	4.60	2.20							
	RTMC100118-220S5	80479	4.53	2.20							
	BRTMC100118-315S4	80481	5.51	3.15							

Standard Thread Application by Toolholder

Toolholder	Min.Thread Dia.						
	D2 (Inch)	ISO (coarse)	ISO (fine)	UNC	UN/UNF/UNEF/UNS	BSF	BSP(G)
RTMC 075067-110S2	.67	M20x2.5	M19x1; M19x1.5; M20x2	-	7/8-10UNS; 15/16-12UN; 7/8-14UNF; 3/4-16UNF; 3/4-18UNS; 3/4-20UNEF	7/8-11; 7/8-12; 7/8-14; 7/8-16	1/2-14
RTMC 075067-145S2							
RTMC 100067-110S2							
RTMC 100067-145S2	.75	M22x2.5 M24x3	M21x1; M21x1.5; M22x2	7/8-9; 1-8	7/8-20UNEF; 7/8-18UNS; 7/8-16UN; 7/8-14UNF; 7/8-12UN; 7/8-10UNS	7/8-16; 7/8-14; 15/16-12; 15/16-11	5/8-14
RTMC 100075-125S2							
RTMC 100075-175S2							
RTMC 100081-150S3							
RTMC 100081-175S3	.81	M24x3	M22x1; M23x1.5; M23x2; M23.5x2.5	1-8	15/16-9UN; 1-10UNS; 15/16-12UN; 1-14UNS; 15/16-16UN; 7/8-18UNS; 7/8-20UNEF	1-11; 1-12; 1-14; 1-16	5/8-14
RTMC 100087-170S3							
RTMC 100087-220S3	.87	M27x3	M24x1; M24x1.5; M25x2; M25x2.5	-	1 1/16-8UN; 1-9UN; 1-10UNS; 1-12UNF; 1-14UNS; 1-16UN; 1-18UN; 15/16-20UNEF	1-11; 1-12; 1-14; 1-16	3/4-14
RTMC 100118-220S5							
BRTMC 100118-315S4	1.18	-	M32x1; M32x1.5; M33x2; M33x2.5; M34x3	-	1 3/8-8UN; 1 3/8-9UN; 1 3/8-10UN; 1 3/16-12UN; 1 3/8-14UNS; 1 1/16-16UN; 1 1/16-18UNEF; 1 1/16-20UN	1 3/8-11; 1 3/8-12; 1 3/8-14; 1 3/8-16	1-11

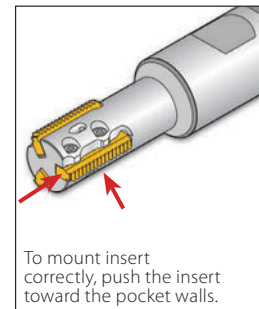
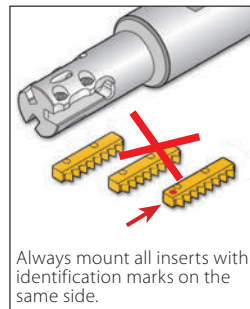
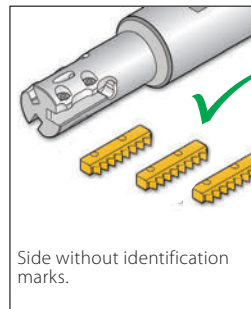
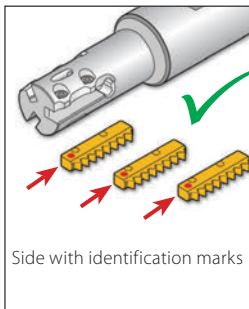

Conical Toolholders (MiTM 25)

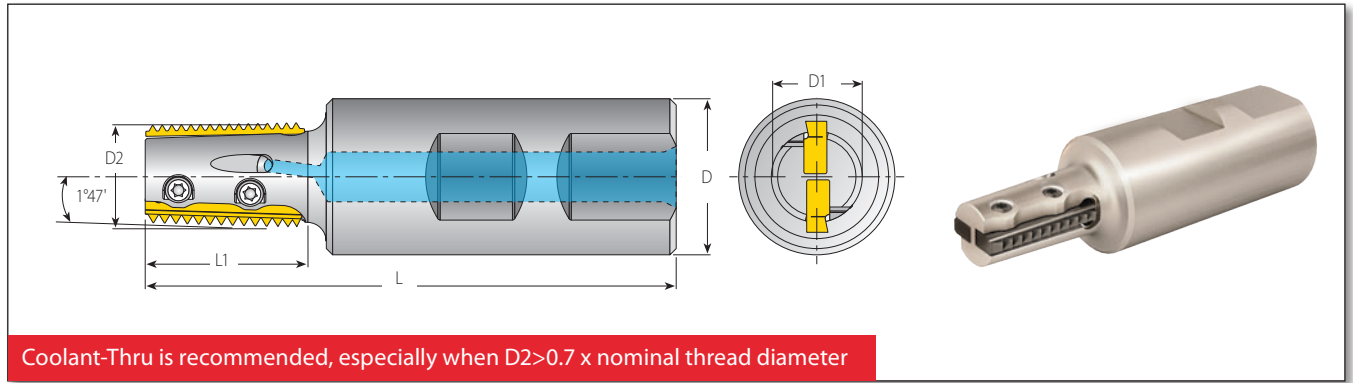

Coolant-Thru is recommended, especially when $D2 > 0.7 \times$ nominal thread diameter

RTMNC - for Conical Threads

Spare Parts

Insert Style	Ordering Code	EDP No.	Dimensions Inch						No. of Flutes	Spare Parts	
			L	L1	D	D1	D2	Z			
25	RTMNC075067-110S2	80749	3.29	1.10	.75	.55	.68	2	SLD4IP8 (M4x0.7) (80533)	Torx+ Screwdriver	
	RTMNC100067-110S2	80473	3.50	1.10	1.00	.55	.68	2			
	RTMNC100087-170S3	80477	4.09	1.70	1.00	.71	.87	3			
	RTMNC100110-170S4	80480	4.06	1.70	1.00	1.10	1.12	4			

MiTM

Conical Thread Application by Toolholder

Toolholder	Thread Dia.			
	D2 (Inch)	NPT	NPTF	BSPT
RTMNC075067-110S2	.68	1/2-14; 3/4-14; 1-11.5; 1 1/4-11.5; 1 1/2-11.5; 2-11.5	1/2 -14; 3/4-14; 1-11.5; 1 1/4-11.5; 1 1/2-11.5; 2-11.5	1/2 -14; 3/4-14
RTMNC100067-110S2				
RTMNC100087-170S3	.87	3/4-14; 1-11.5; 1 1/4-11.5; 1 1/2-11.5; 2-11.5	3/4-14; 1-11.5; 1 1/4-11.5; 1 1/2-11.5; 2-11.5	3/4-14; 1-11; 1 1/4-11; 1 1/2-11; 2-11; 2 1/2-11; 3-11; 4-11; 5-11; 6-11
RTMNC100110-170S4	1.12	1-11.5; 1 1/4-11.5; 1 1/2-11.5; 2-11.5	1-11.5; 1 1/4-11.5; 1 1/2-11.5; 2-11.5	1-11; 1 1/4-11; 1 1/2-11; 2-11; 2 1/2-11; 3-11; 4-11; 5-11; 6-11

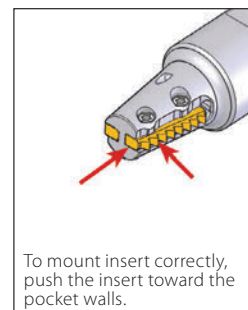
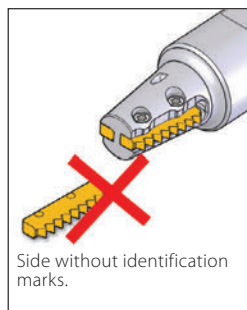
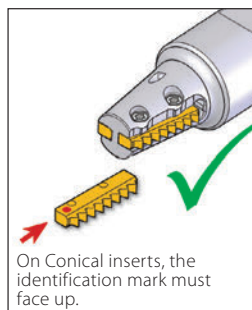

Shell Mill (MiTM 25)

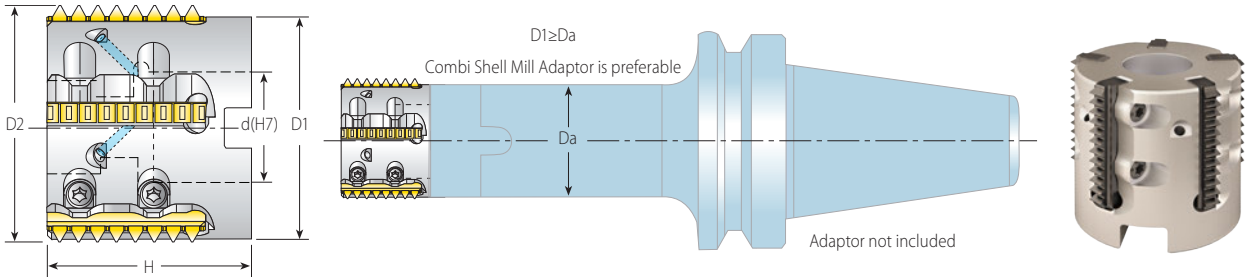

Coolant-Thru is recommended, especially when $D2 > 0.7 \times$ nominal thread diameter

Conical and Standard Shell Mills

Insert Style	Ordering Code	EDP No.	Dimensions Inch					No. of Flutes	Spare Parts		
			D1	D2	d(H7)	H	Z		Location Screw x2	Torx+ Screwdriver	Holder Screw
Standard	25	RTMC-D150-050-2555	80569	1.38	1.54	.50	1.26	5	SLD4IP8 (M4x0.7) (80533)	Use the included Vardex Torx+ screwdriver only. Recommended max. torque 1.2 NxM (70231)	1/4"-28x1.25 (70263)
		RTMC-D190-075-2557	80570	1.77	1.93	.75	1.38	7			3/8"-24x1.25 (70223)
		RTMC-D230-100-2559	80571	2.17	2.32	1.00	1.58	9			1/2"-20x1.50 (70262)
Conical	RTMNC-D150-050-2555	80572	1.38	1.53*	.50	1.26	5	1/4"-28x1.25 (70263)			

* For inserts 8NPT and 8NPTF use for CNC program 1.55".

Standard Thread Applications by Toolholder

Toolholder		Min. Thread Dia.				
	D2 (Inch)	ISO (fine)	UN/UNF/UNEF/UNS	BSW	BSP(G)	
Standard	RTMC-D150-050-2555	1.54	M42x1; M42x1.25; M42 x1.5; M45x2; M45x3	1 ¹¹ / ₁₆ -12UNF; 1 ³ / ₄ -14UNS; 1 ⁵ / ₈ -16UN 1 ⁵ / ₈ -18UNEF; 1 ⁵ / ₈ -20UN;	1 ³ / ₄ -16 1 ³ / ₄ -12	1 ¹ / ₂ -11
	RTMC-D190-075-2557	1.93	M52x1; M52x1.25; M55x1.5; M55x2; M55x3	2 ¹ / ₈ -12UN; 2 ¹ / ₁₆ -16UN; 2 ¹ / ₈ -20UN; 2 ³ / ₈ -8UN 2 ¹ / ₄ -10UNS; 2 ¹ / ₄ -14UNS; 2 ¹ / ₄ -18UNS	2 ¹ / ₄ -16 2 ¹ / ₄ -12	1 ³ / ₄ -11
	RTMC-D230-100-2559	2.32	M64x1; M64x1.25; M64x1.5; M64x2; M65x3	2 ¹ / ₂ -18UN; 2 ¹ / ₂ -20UN; 2 ¹ / ₂ -8UN 2 ¹ / ₂ -12UN; 2 ¹ / ₂ -10UN; 2 ¹ / ₂ -14UN; 2 ¹ / ₂ -16UN	2 ¹ / ₂ -16 2 ¹ / ₂ -12	2 ¹ / ₄ -11

Conical Thread Applications by Toolholder

Toolholder		Thread Dia.			
	D2 (Inch)	NPT	NPTF	BSPT	
Conical	RTMNC-D150-050-2555	1.53*	1 ¹ / ₂ - 11.5; 2-11.5; 2 ¹ / ₂ (and up) -8	1 ¹ / ₂ - 11.5; 2-11.5	1 ¹ / ₂ -6 x11

* For inserts 8NPT and 8NPTF use for CNC program 1.55".

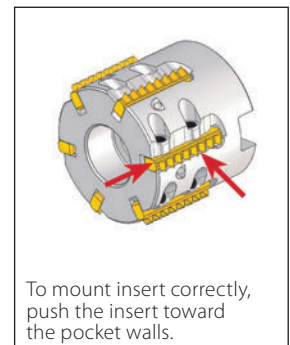
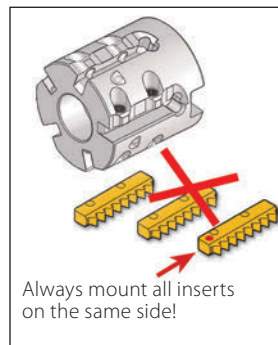
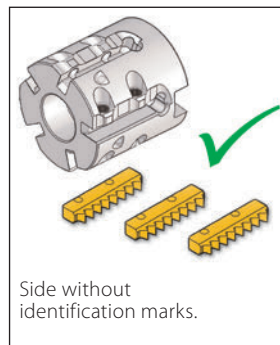
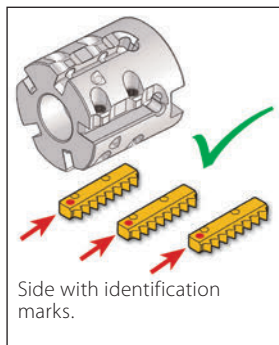

Standard Toolholders (MiTM 40)

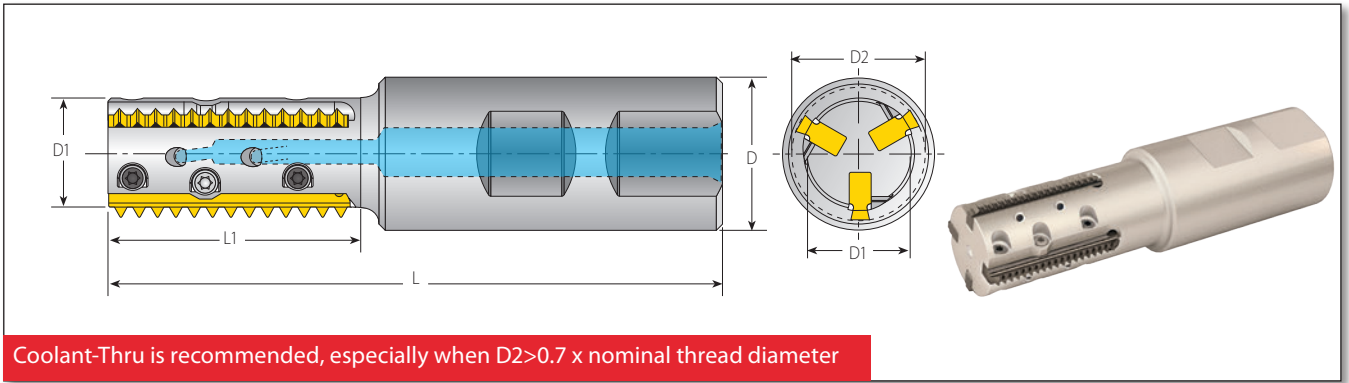

RTMC - for Standard Threads

Insert Style	Ordering Code	EDP No.	Dimensions Inch					No. of Flutes	Spare Parts		
			L	L1	D	D1	D2		Z	Location Screw	Clamping Screw x2
40	RTMC100087-169L3	80618	4.00	1.69	1.00	.71	.87	3	SLD4IP8A (M4x0.7) (80533)	SCD4IP8 (M4x0.7) (80622)	Torx+ Screwdriver KIP8 • Use the included Vardex Torx+ screwdriver only. • Recommended max. torque 1.2 Nm (70231)
	RTMC100087-256L3	80619	4.87	2.56	1.00	.71	.87	3			
	RTMC125118-215L4	80620	4.55	2.15	1.25	1.02	1.18	4			
	BRTMC125118-315L3	80621	5.35	3.15	1.25	1.02	1.18	3			

Standard Thread Application by Toolholder

Toolholder	Min. Thread Dia.								
	D2 (Inch)	ISO (coarse)	ISO (fine)	UNC	UN/UNF/UNEF/UNS			BSF	BSP(G)
RTMC100087-169L3	.87	M27x3	M24x1; M24x1.5 M25x2; M25x2.5	-	1 ¹¹ / ₁₆ -8UN; 1-9UN; 1-10UNS; 1-12UNF; 1-14UNS; 1-16UN; 1-18UN; 1 ¹ / ₁₆ -20UNEF			1-11; 1-12; 1-14; 1-16;	¾-14
RTMC100087-256L3	.87	M27x3	M24x1; M24x1.5 M25x2; M25x2.5	-	1 ¹¹ / ₁₆ -8UN; 1-9UN; 1-10UNS; 1-12UNF; 1-14UNS; 1-16UN; 1-18UN; 1 ¹ / ₁₆ -20UNEF			1-11; 1-12; 1-14; 1-16;	¾-14
RTMC125118-215L4	1.18	-	M32x1; M32x1.5 M33x2; M33x2.5; M34x3	-	1 ³ / ₈ -8UN; 1 ³ / ₈ -9UN; 1 ³ / ₈ -10UN; 1 ¹ / ₁₆ -12UN; 1 ³ / ₈ -14UNS; 1 ¹ / ₁₆ -16UN; 1 ¹ / ₁₆ -18UNEF; 1 ¹ / ₁₆ -20UN			1 ³ / ₈ -11; 1 ³ / ₈ -12; 1 ³ / ₈ -14; 1 ³ / ₈ -16	1-11
BRTMC125118-315L3	1.18	-	M32x1; M32x1.5 M33x2; M33x2.5; M34x3	-	1 ³ / ₈ -8UN; 1 ³ / ₈ -9UN; 1 ³ / ₈ -10UN; 1 ¹ / ₁₆ -12UN; 1 ³ / ₈ -14UNS; 1 ¹ / ₁₆ -16UN; 1 ¹ / ₁₆ -18UNEF; 1 ¹ / ₁₆ -20UN			1 ³ / ₈ -11; 1 ³ / ₈ -12; 1 ³ / ₈ -14; 1 ³ / ₈ -16	1-11

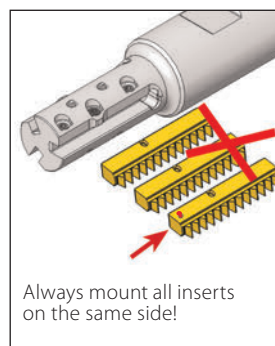
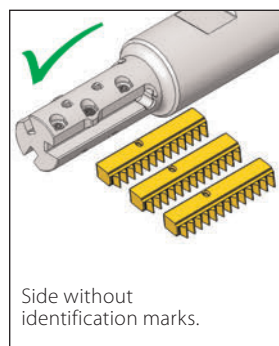
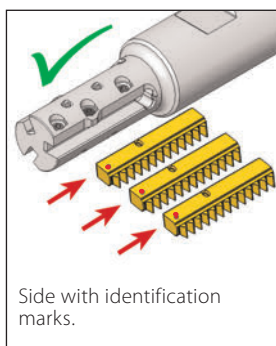

2 Step Clamping System

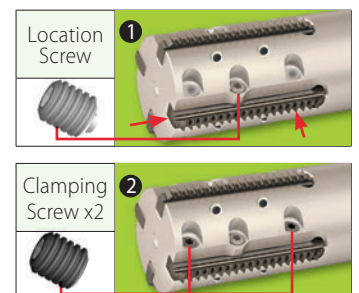

Shell Mill (MiTM 40)

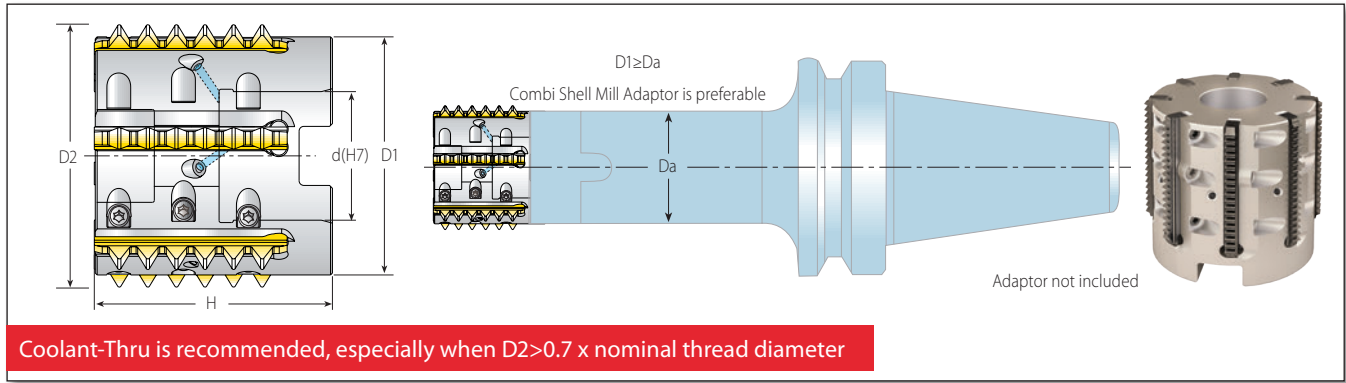

Coolant-Thru is recommended, especially when D2 > 0.7 x nominal thread diameter

MITM

Conical and Standard Shell Mills

Spare Parts

Insert Style	Ordering Code	EDP No.	Dimensions Inch					No. of Flutes	Spare Parts				
			D1	D2	d(H7)	H	Z		Location Screw	Clamping Screw x2	Torx+ Screwdriver	Holder Screw	
Standard	RTMC-D190-075-40L7	80623	1.77	1.93	.75	1.97	7	SLD4IP8A (M4x0.7) (80533)	SCD4IP8 (M4x0.7) (80622)	Torx+ Screwdriver	Holder Screw	•Use the included Vardex Torx+ screwdriver only. •Recommended max. torque 1.2 NxM (70231)	3/8"-24x1.25 (70223)
	RTMC-D230-100-40L9	80624	2.17	2.32	1.00	2.00	9						1/2"-20x1.5 (70224)
Conical	RTMNC-D190-075-40L7	80625	1.77	1.93	.75	1.97	7						3/8"-24x1.25 (70223)

Standard Thread Application by Toolholder

Toolholder		Min. Thread Dia.				
		D2 (Inch)	ISO (fine)	UN/UNF/UNEF/UNS	BSW	BSP(G)
Standard	RTMC-D190-075-40L7	1.93	M52x1; M55x1.5; M55x2; M55x3	2 1/8 -8UN; 2 1/8 -12UN; 2 1/16 -16UN; 2 1/8 -20UN; 2 1/4 -10UNS; 2 1/4 -14UNS; 2 1/4 -18UNS	2 1/4 -12; 2 1/4 -16	1 3/4 -11
	RTMC-D230-100-40L9	2.32	M64x1; M64x1.5; M64x2; M65x3	2 1/2 -8UN; 2 1/2 -10UNS; 2 1/2 -12UN; 2 1/2 -14UNS; 2 1/2 -16UN; 2 1/2 -18UNS; 2 1/2 -20UN	2 1/2 -12; 2 1/2 -16	2 1/4 -11

Conical Thread Application by Toolholder

Toolholder		Min. Thread Dia.			
		D2 (Inch)	NPT	NPTF	BSPT
Conical	RTMNC-D190-075-40L7	1.93	2-11.5; 2 1/2-8 (and up)	2-11.5; 2 1/2-8; 3-8	2-6x11

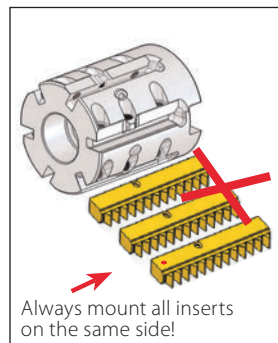
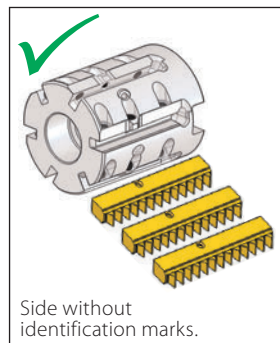
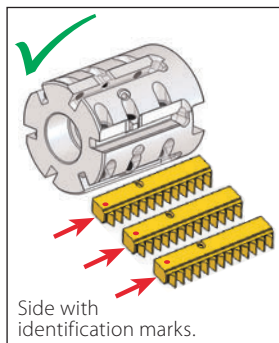

2 Step Clamping System

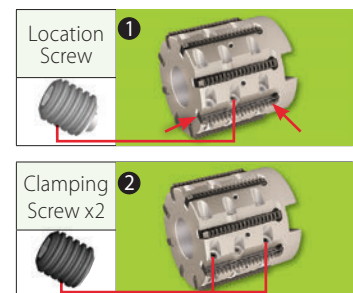

Standard Toolholders (MiTM 41)

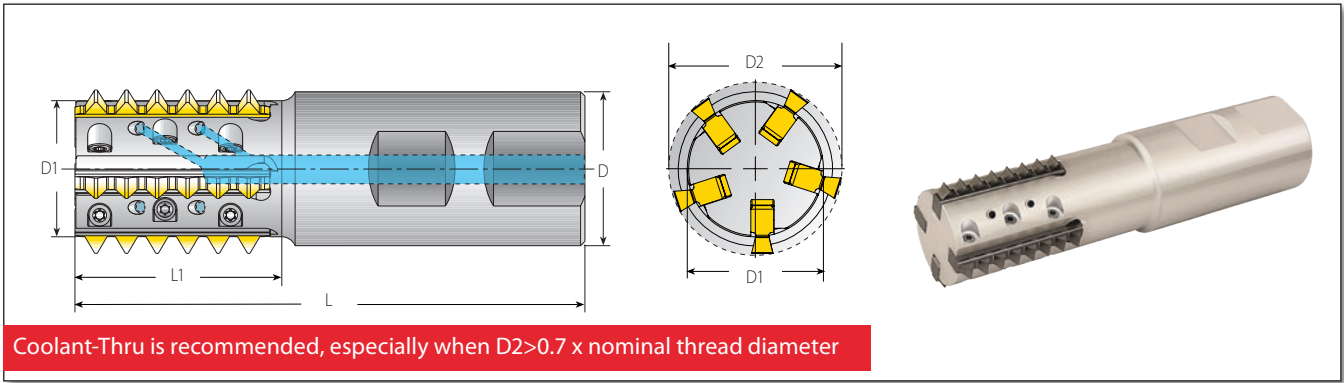

Coolant-Thru is recommended, especially when $D2 > 0.7 \times$ nominal thread diameter

RTMC - for Standard Threads

Insert Style	Ordering Code	EDP No.	Dimensions Inch					No. of Flutes	Spare Parts		
			L	L1	D	D1	D2*		Z	Location Screw x2	Clamping Screw
41	RTMC100083-177B1	80654	4.13	1.77	1.00	.63	.835	1	SLD4IP8A (M4x0.7) (80533)	SCD4IP8 (M4x0.7) (80622)	Torx+ Screwdriver KIP8 •Use the included Vardex Torx+ screwdriver only. •Recommended max. torque 1.2 NxM (70231)
	RTMC100096-169B2	80864	4.13	1.69	1.00	.76	.97	2			
	RTMC125118-169B3	80865	4.13	1.69	1.25	.95	1.18	3			
	RTMC125118-256B3	80866	5.00	2.56	1.25	.95	1.18	3			
	RTMC125141-169B5	80867	4.13	1.69	1.25	1.11	1.42	5			
	RTMC125141-256B4	80868	4.98	2.56	1.25	1.11	1.42	4			

Standard Thread Application by Toolholder

Toolholder	Min. Thread Dia.							
	D2* (Inch)	ISO (coarse)	ISO (fine)	UNC	UN/UNF/UNEF/UNS	BSW/BSF	NPT	NPTF
RTMC100083-177B1	.835	M27x3; M30x3.5; M33x3.5; M36x4; M39x4	M30x3; M42x4	1-8, 1 1/8-7; 1 1/4-7; 1 3/8-6; 1 1/2-6	1 1/16-8UN; 1 1/16-6UN	1-8BSW; 1 1/8-7BSW	-	-
RTMC100096-169B2	.97	M30x3.5; M36x4	M28x3; M45x4	1 1/8-7; 1 3/8-6	1 1/8-8UN; 1 1/16-6UN	1 3/8-8BSF; 1 1/4-7BSW	-	-
RTMC125118-169B3	1.18	M36x4; M42x4.5	M34x3; M34x3.5; M45x4	1 3/8-6	1 3/8-8UN; 1 1/16-6UN	1 3/8-8BSF; 1 3/4-7BSF; 1 1/2-6BSW	-	-
RTMC125118-256B3	1.18	M36x4; M42x4.5	M34x3; M34x3.5; M45x4	1 3/8-6	1 3/8-8UN; 1 1/16-6UN	1 3/8-8BSF; 1 3/4-7BSF; 1 1/2-6BSW	-	-
RTMC125141-169B5	1.42	M42x4.5; M48x5; M56x5.5; M64x6	M40x3; M40x3.5; M42x4; M70x6	1 3/4-5; 2-4.5; 2 1/2-4	1 3/8-8UN; 1 3/8-6UN	1 3/8-8BSF; 1 3/4-7BSF; 1 1/8-6BSF	2 1/2-8	2 1/2-8
RTMC125141-256B4	1.42	M42x4.5; M48x5; M56x5.5; M64x6	M40x3; M40x3.5; M42x4; M70x6	1 3/4-5; 2-4.5; 2 1/2-4	1 3/8-8UN; 1 3/8-6UN	1 3/8-8BSF; 1 3/4-7BSF; 1 1/8-6BSF	2 1/2-8	2 1/2-8

* For external applications, inserts R41E... use for CNC program (D2 +0.024").

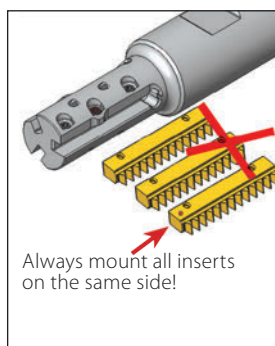
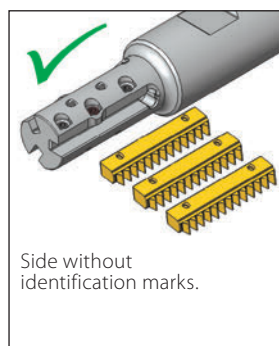
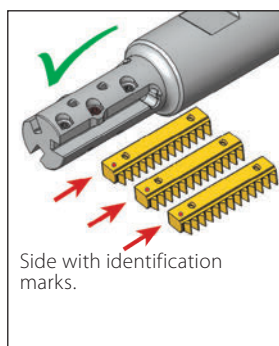

2 Step Clamping System

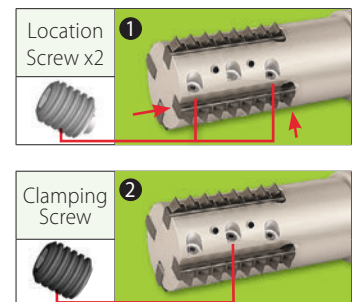

Shell Mill (MiTM 41)

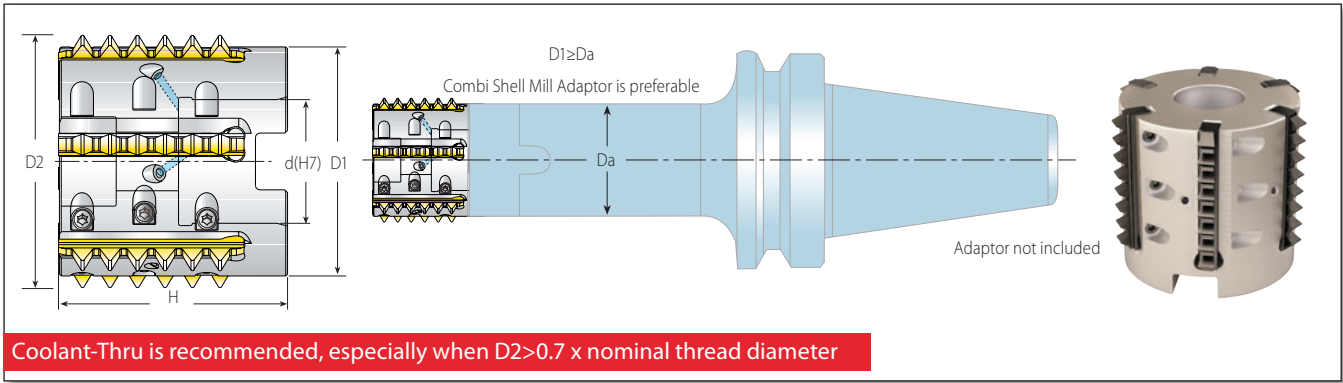

Coolant-Thru is recommended, especially when D2 > 0.7 x nominal thread diameter

MITM

Standard Shell Mill								Spare Parts			
Insert Style	Ordering Code		Dimensions Inch				No. of Flutes				
			D1	D2*	d(H7)	H	Z	Location Screw x2	Clamping Screw	Torx+ Screwdriver	Holder Screw
41	RTMC-D209-075-41B5	80869	1.77	2.08*	.75	2.00	5	SLD4IP8A (M4x0.7) (80533)	SCD4IP8 (M4x0.7) (80622)	KIP8 •Use the included Vardex Torx+ screwdriver only. •Recommended max. torque 1.2 Nm (70231)	3/8"-24x1.5 (70264)
	RTMC-D248-100-41B6	80870	2.17	2.48*	1.00	2.00	6				1/2"-20x1.5 (70224)

Standard Thread Application by Toolholder

Toolholder	D2* (Inch)	Min. Thread Dia.						
		ISO (coarse)	ISO (fine)	UNC	UN/UNF/UNEF/UNS	BSF	NPT	NPTF
RTMC-D209-075-41B5	2.08*	M64x6	M58x4; M70x6	2 1/2-4	2 3/8-6UN; 2 3/8-8UN	2 3/8-8; 2 1/2-6	2 1/2-8	2 1/2-8
RTMC-D248-100-41B6	2.48*	-	M68x4; M70x6	3-4	2 3/4-6UN; 2 3/4-8UN	2 3/4-8; 2 3/4-6	2 1/2-8	2 1/2-8

* For external applications, inserts R41E... use for CNC program (D2+.024").

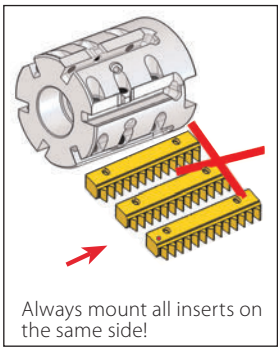
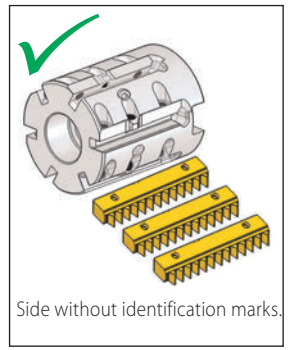
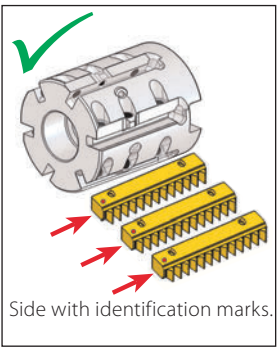

2 Step Clamping System

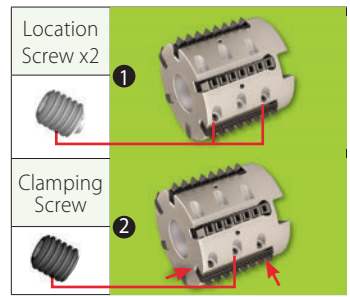



Recommended Grades, Cutting Speeds Vc [ft/min] and Feed f [inch/tooth]

Material Group	Vargus No.	Material	Hardness Brinell HB	Vc [ft/min]		Feed f [inch/tooth]		
				VBX	VTX	(Excluding MiTM 19)	(for MiTM 19)	
P Steel	1	Unalloyed Steel	Low Carbon (C=0.1-0.25%)	125	328-689	295-591	.0039-.0138	.0024-.0079
	2		Medium Carbon (C=0.25-0.55%)	150	328-591	295-558	.0039-.0157	.0024-.0098
	3		High Carbon (C=0.55-0.85%)	170	328-558	295-525	.0039-.0138	.0024-.0079
	4	Low Alloy Steel (alloying elements ≤5%)	Non Hardened	180	262-459	295-509	.0039-.0157	.0024-.0098
	5		Hardened	275	262-492	262-525	.0039-.0138	.0024-.0079
	6		Hardened	350	230-459	230-492	.0039-.0118	.0024-.0079
	7	High Alloy Steel (alloying elements >5%)	Annealed	200	197-427	230-377	.0039-.0138	.0024-.0079
	8		Hardened	325	230-361	197-328	.0039-.0079	.0024-.0039
	9	Cast Steel	Low Alloy (alloying elements <5%)	200	328-558	328-558	.0039-.0118	.0024-.0079
	10		High Alloy (alloying elements >5%)	225	230-394	230-427	.0039-.0079	.0024-.0039
M Stainless Steel	11	Stainless Steel Ferritic	Non Hardened	200	328-558	394-591	.0039-.0118	.0024-.0079
	12		Hardened	330	328-558	394-591	.0039-.0079	.0024-.0039
	13	Stainless Steel Austenitic	Austenitic	180	230-459	328-459	.0039-.0118	.0024-.0079
	14		Super Austenitic	200	230-459	328-459	.0039-.0079	.0024-.0039
	15	Stainless Steel Cast Ferritic	Non Hardened	200	230-459	328-459	.0039-.0118	.0024-.0079
	16		Hardened	330	230-459	328-459	.0039-.0079	.0024-.0039
	17	Stainless Steel Cast Austenitic	Austenitic	200	230-394	328-394	.0039-.0118	.0024-.0079
	18		Hardened	330	230-394	328-394	.0039-.0079	.0024-.0039
K Cast Iron	28	Malleable Cast Iron	Ferritic (short chips)	130	197-427	328-394	.0020-.0063	.0012-.0039
	29		Pearlitic (long chips)	230	197-394	262-328	.0016-.0039	.0008-.0024
	30	Grey Cast Iron	Low Tensile Strength	180	197-427	262-328	.0039-.0118	.0024-.0079
	31		High Tensile Strength	260	197-328	262-328	.0039-.0079	.0024-.0039
	32	Nodular Sg Iron	Ferritic	160	197-410	262-328	.0039-.0118	.0024-.0079
	33		Pearlitic	260	164-295	197-295	.0039-.0079	.0024-.0039
N Non-Ferrous Metals	34	Aluminium Alloys Wrought	Non Aging	60	328-820	-	.0059-.0217	.0035-.0118
	35		Aged	100	328-591	-	.0059-.0197	.0035-.0118
	36	Aluminium Alloys	Cast	75	492-1.312	-	.0059-.0197	.0035-.0118
	37		Cast & Aged	90	492-919	-	.0039-.0157	.0024-.0098
	38	Aluminium Alloys	Cast Si 13-22%	130	262-492	-	.0059-.0197	.0035-.0118
	39	Copper and Copper Alloys	Brass	90	394-689	328-656	.0059-.0197	.0035-.0118
40	Bronze And Non Leaded Copper		100	394-689	328-656	.0039-.0157	.0024-.0098	
S Heat Resistant Material	19	High Temperature Alloys	Annealed (iron based)	200	66-148	66-131	.0039-.0079	.0024-.0039
	20		Aged (iron based)	280	66-98	66-98	.0016-.0039	.0008-.0024
	21		Annealed (nickel or cobalt based)	250	49-66	49-66	.0016-.0039	.0008-.0024
	22		Aged (nickel or cobalt based)	350	33-49	33-49	.0016-.0039	.0008-.0024
	23	Titanium Alloys	Pure 99.5 Ti	400Rm	230-459	230-394	.0016-.0039	.0008-.0024
24	α+β Alloys		1050Rm	66-164	66-164	.0016-.0039	.0008-.0024	
H Hardened Material	25	Extra Hard Steel	Hardened & Tempered	45-50HRc	49-148	49-148	.0024-.0047	.0016-.0028
	26			51-55HRc	49-131	49-131	.0016-.0031	.0008-.0020

MiTM

Grades

Grade	Application	Sample
VBX	TiCN coated carbide grade. Excellent grade for steels and general use.	
VTX	TiAlN coated carbide grade. Ideal for Stainless Steels.	



STANDARD

Thread Milling

Inserts | Toolholders

Vardex Ordering Code System

■ Thread Milling Inserts

3	B	I	12	UN	TM2	F	VBX	028/...
1	2	3	4	5	6	7	8	9

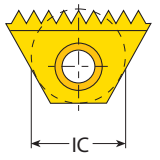
1 - Insert Size 6.0 - 6.0 mm 2 - 1/4" 3 - 3/8" 3B - 3/8"B 4 - 1/2" 5 - 5/8" 6B - 3/4"B		2 - Cutting Edge Length B - TMB	3 - Type of Insert E - External I - Internal EI - External + Internal	4 - Pitch 80 - 4TPI 0.35 - 6.0mm
5 - Standard ISO - ISO Metric UN - American UN UNJ - UNJ W - Whitworth for BSW, BSP NPT - NPT NPTF - NPTF NPS - NPS	BSPT - British Standard Pipe Thread PG - Pg DIN 40430 ACME - ACME TR - Trapez DIN 103	6 - System TM2 TM	8 - Coarse Pitch Inserts 028/...	9 - Carbide Grade VBX VTX VK2
		7 - Pitch Type F = Fine Pitch		

■ Thread Milling Toolholders

B	TM	N	C	075	-	3	B	-	LH	-	10
1	2	3	4	5		6	7	8	9		

1 - Shank Type B - Anti Vibration System	2 - System TM - Thread Milling	3 - Holder Type 2 - Twin Flute M - Mini L - Long Tool N - Tapered Holder V - Vertical Holder S - Single Point O - Offset W - Wide Cut. Dia.	4 - Cooling C - Coolant Channel
5 - Shank Dia. 0375 - 3/8" 050 - 1/2" 0625 - 5/8" 075 - 3/4" 100 - 1" 125 - 1 1/4"	6 - Insert Size 6.0 - 6.0mm 2 - 1/4" 3 - 3/8" 3B - 3/8"B 4 - 1/2" 5 - 5/8" 6B - 3/4"B	7 - Cut. Edge Length B - TMB	9 - RH / LH Holder None - Right Hand LH - Left Hand
		8 - Serial No. (for TMO Holders) 1 - 16	10 - Serial No. (for Coarse Pitch Holders) 124/...

■ Thread Milling Shell Mill

TMSH	-	D250	-	075	-	3	B
1		2		3		4	5

1 - System Thread Mill Shell Mill	2 - Cutting Dia. 150 - 1.50" 200 - 1.97" 250 - 2.48" 300 - 3.15" 400 - 3.94" 500 - 4.92"	3 - Drive Hole Dia. 1/2", 3/4", 1", 1 1/4", 1 1/2"	4 - Insert Size 2 - 1/4" 3 - 3/8" 3B - 3/8"B 5 - 5/8" 6B - 3/4"B
5 - Cut. Edge Length B - TMB			

Thread Milling Standard System

TMMC
Miniature Applications



No. of Flutes (Z) 1
 Cutting Dia. (D2) .35
 Tool Overhang (L1) .57-67

TMC
Standard Applications

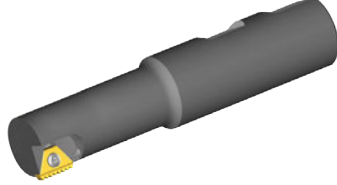

No. of Flutes (Z) 1
 Cutting Dia. (D2) .45-1.81
 Tool Overhang (L1) .47-2.56

TMC 124/...
Coarse Pitch Thread



No. of Flutes (Z) 1
 Cutting Dia. (D2) .35-.87
 Tool Overhang (L1) .59-1.57

TMLC
For Long Threads

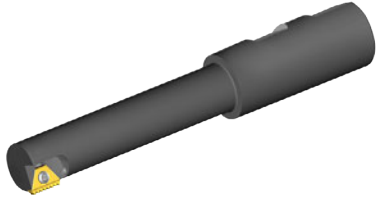
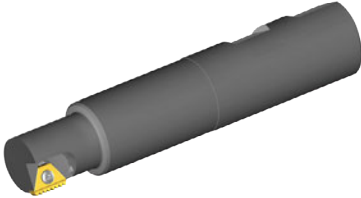
No. of Flutes (Z) 1
 Cutting Dia. (D2) .45-1.81
 Tool Overhang (L1) .67-3.86

TMNC
For Conical Applications



No. of Flutes (Z) 1
 Cutting Dia. (D2) .61-1.46
 Tool Overhang (L1) .87-2.28

TM2C
Fast Infeed



No. of Flutes (Z) 2
 Cutting Dia. (D2) .67-2.05
 Tool Overhang (L1) .79-2.56

TMOC
For Fewer Cycles

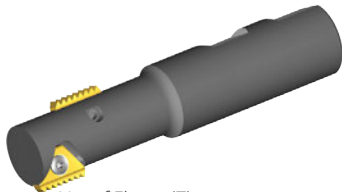

No. of Flutes (Z) 1
 Cutting Dia. (D2) .57-1.18
 Tool Overhang (L1) .98-2.05

TMSH
**Fast Machining in Large
 Diameters and Deep Holes**



No. of Flutes (Z) 4-9
 Cutting Dia. (D2) 1.5-4.92
 Tool Overhang (L1) Max. 7.87

TMSC
**For Short Threads
 Economical Solutions**



No. of Flutes (Z) 1
 Cutting Dia. (D2) .49
 Tool Overhang (L1) .98

TMVC
For Large Pitches

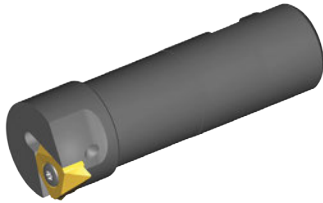

No. of Flutes (Z) 1
 Cutting Dia. (D2) 1.81
 Tool Overhang (L1) 2.36

TM Standard

ISO Metric

External / Internal

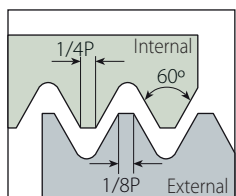

Defined by: R262 (DIN 13)
Tolerance class: 6g/6H

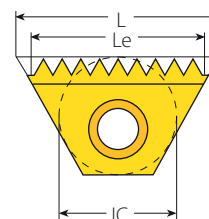

Standard TM

Standard TM

Insert Size		Pitch	Ordering Code		Le	Teeth	Toolholder
IC	L Inch	mm	External	Internal	Inch		
6.0mm	.41	0.5		6.0I0.5ISOTM...	.39	20	TMMC...-6.0
		0.75		6.0I0.75ISOTM...	.38	13	
		1.0		6.0I1.0ISOTM...	.35	9	
		1.25		6.0I1.25ISOTM...	.34	7	
		1.5		6.0I1.5ISOTM...	.35	6	
1/4"	.43	0.5		2I0.5ISOTM2...	.39	20	TMC...-2 TMSH...-2
		0.75	2E0.75ISOTM2...	2I0.75ISOTM2...	.41	14	
		1.0	2E1.0ISOTM2...	2I1.0ISOTM2...	.39	10	
		1.25	2E1.25ISOTM2...	2I1.25ISOTM2...	.39	8	
		1.25		2I1.25ISOTM2...	.34	7	
		1.5	2E1.5ISOTM2...	2I1.5ISOTM2...	.35	6	
3/8"	.63	0.5		3I0.5ISOTM2...	.59	30	TMC...-3 TMSH...-3
		0.75	3E0.75ISOTM2...	3I0.75ISOTM2...	.59	20	
		0.8		3I0.8ISOTM2...	.57	18	
		1.0	3E1.0ISOTM2...	3I1.0ISOTM2...	.55	14	
		1.0		3I1.0ISOTM2...	.59	15	
		1.25	3E1.25ISOTM2...	3I1.25ISOTM2...	.59	12	
		1.5	3E1.5ISOTM2...	3I1.5ISOTM2...	.59	10	
		1.75	3E1.75ISOTM2...	3I1.75ISOTM2...	.55	8	
3/8"B	.87	1.0	3BE1.0ISOTM2...	3BI1.0ISOTM2...	.87	22	BTMC...-3B TMSH...-3B
		1.25	3BE1.25ISOTM2...	3BI1.25ISOTM2...	.84	17	
		1.5	3BE1.5ISOTM2...	3BI1.5ISOTM2...	.83	14	
		1.75	3BE1.75ISOTM2...	3BI1.75ISOTM2...	.83	12	
		2.0	3BE2.0ISOTM2...	3BI2.0ISOTM2...	.87	11	
5/8"	1.06	1.0		5I1.0ISOTM2...	1.02	26	TMC...-5 TMSH...-5
		1.25	5E1.25ISOTM2...	5I1.25ISOTM2...	.98	20	
		1.5	5E1.5ISOTM2...	5I1.5ISOTM2...	1.00	17	
		1.75	5E1.75ISOTM2...	5I1.75ISOTM2...	.96	14	
		2.0	5E2.0ISOTM2...	5I2.0ISOTM2...	.94	12	
		2.5	5E2.5ISOTM2...	5I2.5ISOTM2...	.98	10	
		3.0	5E3.0ISOTM2...	5I3.0ISOTM2...	.94	8	
		3.5	5E3.5ISOTM2...	5I3.5ISOTM2...	.96	7	
		4.0	5E4.0ISOTM2...	5I4.0ISOTM2...	.94	6	
	4.5	5E4.5ISOTM2...	5I4.5ISOTM2...	.89	5		

All inserts have 2 cutting edges, except MiniTM (IC 6.0 mm) which has one cutting edge.

ISO Metric (con't)

External / Internal

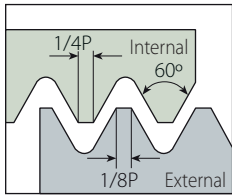

Defined by: R262 (DIN 13)
Tolerance class: 6g/6H

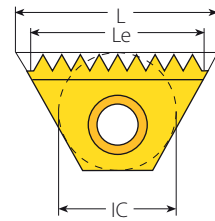

Standard TM

Standard TM

Insert Size		Pitch	Ordering Code		Le	Teeth	Toolholder
IC	L Inch	mm	External	Internal	Inch		
3/4"B	1.52	1.5	6BE1.5ISOTM2...	6BI1.5ISOTM2...	1.42	24	TMC..-6B TMSH...-6B
		2.0	6BE2.0ISOTM2...	6BI2.0ISOTM2...	1.42	18	
		2.5	6BE2.5ISOTM2...	6BI2.5ISOTM2...	1.38	14	
		3.0	6BE3.0ISOTM2...	6BI3.0ISOTM2...	1.42	12	
		4.0	6BE4.0ISOTM2...	6BI4.0ISOTM2...	1.26	8	
		4.5	6BE4.5ISOTM2...	6BI4.5ISOTM2...	1.24	7	
		5.0	6BE5.0ISOTM2...	6BI5.0ISOTM2...	1.18	6	
		5.5	6BE5.5ISOTM2...	6BI5.5ISOTM2...	1.30	6	
		6.0	6BE6.0ISOTM2...	6BI6.0ISOTM2...	1.18	5	

ISO Metric (con't)

Internal

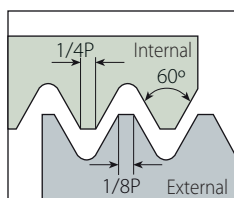

Defined by: R262 (DIN 13)
Tolerance class: 6g/6H

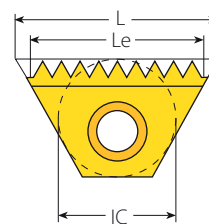
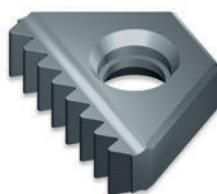

Coarse Pitch TM

Coarse Pitch TM

Thread	Insert Size		Ordering Code	Cutting Edge	Le	Teeth	Toolholder	Bore Dia. Range
	IC	L Inch						
M10 X 0.75	6.0 mm	.41	6.0I0.75ISOTM028/001...	1	.38	13	TMMC050-6.0	.36 - .39
M10 X 0.75			6.0I0.75ISOTM028/001...	1	.38	13	TMMC075-6.0	.36 - .39
M12 X 1.25			6.0I1.25ISOTM028/002...	1	.34	7	TMMC050-6.0	.42 - .45
M12 X 1.25			6.0I1.25ISOTM028/002...	1	.34	7	TMMC075-6.0	.42 - .45
M12 X 1.75	1/4"	.43	6.0I1.75ISOTM028/003...	1	.34	5	TMMC075-6.0-124/203	.40 - .75
M14 X 2.0			2I2.0ISOTM028/004...	2	.39	5	TMC050-2	.46 - .77
M14 X 2.0			2I2.0ISOTM028/004...	2	.39	5	TMC075-2	.46 - .77
M16 X 2.0			2I2.0ISOTM028/004...	2	.39	5	TMC050-2	.46 - .77
M16 X 2.0	3/8"	.63	2I2.0ISOTM028/004...	2	.39	5	TMC075-2	.46 - .77
M20 X 2.5			3I2.5ISOTM028/005...	1	.49	5	TMC075-3-124/201	.68 - .76
M22 X 2.5			4I2.5ISOTM028/006...	1	.69	7	TMC100-4-124/202	.76 - 1.24
M24 X 3.0			4I3.0ISOTM028/007...	1	.71	6	TMC100-4-124/202	.81 - 1.29
M27 X 3.0	1/2"	.87	4I3.0ISOTM028/007...	1	.71	6	TMC100-4-124/202	.81 - 1.29
M30 X 3.5			5I3.5ISOTM028/008...	2	.96	7	TMC100-5-124/204	1.03 - 1.41
M33 X 3.5			5I3.5ISOTM028/008...	2	.96	7	TMC100-5-124/204	1.03 - 1.41
M36 X 3.0			5I3.0ISOTM028/009...	2	.94	8	TMC100-5	1.29 - 1.54
M36 X 4.0	5/8"	1.06	5I4.0ISOTM028/010...	2	.94	6	TMC100-5	1.24 - 1.52
M39 X 3.0			5I3.0ISOTM028/009...	2	.94	8	TMC100-5	1.29 - 1.54
M39 X 4.0			5I4.0ISOTM028/010...	2	.94	6	TMC100-5	1.24 - 1.52
M42 X 4.5			5I4.5ISOTM028/011...	2	.89	5	TMC100-5	1.46 - 1.89
M45 X 4.5			5I4.5ISOTM028/011...	2	.89	5	TMC100-5	1.46 - 1.89
M48 X 5.0			5I5.0ISOTM028/075...	2	.79	4	TMC100-5	1.53 - ∞
M52 X 5.0			5I5.0ISOTM028/075...	2	.79	4	TMC100-5	1.53 - ∞

For Toolholder information, see page 282.

ISO Metric (con't)

External / Internal

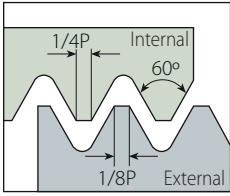

Defined by: R262 (DIN 13)
Tolerance class: 6g/6H

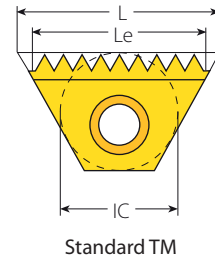

Standard TM

Standard TM Inserts for TMO Toolholders

Insert Size		Pitch	Ordering Code		Toolholder	ECL
IC	L Inch	mm	External	Internal		Inch
1/4"	.43	0.5		2I0.5ISOTM2...	TMOC075-2-8	.75
		0.75	2E0.75ISOTM2...	2I0.75ISOTM2...	TMOC075-2-9	.77
		1.0	2E1.0ISOTM2...	2I1.0ISOTM2...	TMOC075-2-8	.75
		1.25	2E1.25ISOTM2...		TMOC075-2-10	.74
		1.25		2I1.25ISOTM2...	TMOC075-2-10	.64
		1.5	2E1.5ISOTM2...		TMOC075-2-8	.71
		1.5		2I1.5ISOTM2...	TMOC075-2-8	.77
3/8"	.63	0.5		3I0.5ISOTM2...	TMOC075-3-1	1.12
		0.5		3I0.5ISOTM2...	TMOC075-3-10	1.14
		0.75	3E0.75ISOTM2...	3I0.75ISOTM2...	TMOC075-3-11	1.12
		1.0	3E1.0ISOTM2...		TMOC075-3-10	1.10
		1.0		3I1.0ISOTM2...	TMOC075-3-10	1.14
		1.25	3E1.25ISOTM2...	3I1.25ISOTM2...	TMOC075-3-7	1.13
		1.5	3E1.5ISOTM2...	3I1.5ISOTM2...	TMOC075-3-1	1.12
		1.75	3E1.75ISOTM2...	3I1.75ISOTM2...	TMOC075-3-12	1.03
		2.0	3E2.0ISOTM2...	3I2.0ISOTM2...	TMOC075-3-10	1.10
		5/8"	1.06	1.0	5E1.0ISOTM2...	5I1.0ISOTM2...
1.0	5E1.0ISOTM2...			5I1.0ISOTM2...	TMOC100-5-16	1.85
1.25	5E1.25ISOTM2...			5I1.25ISOTM2...	TMOC100-5-13	1.92
1.5	5E1.5ISOTM2...			5I1.5ISOTM2...	TMOC100-5-14	1.89
1.5	5E1.5ISOTM2...			5I1.5ISOTM2...	TMOC100-5-16	1.83
1.75	5E1.75ISOTM2...			5I1.75ISOTM2...	TMOC100-5-15	1.86
2.0	5E2.0ISOTM2...			5I2.0ISOTM2...	TMOC100-5-12	1.73
2.5	5E2.5ISOTM2...			5I2.5ISOTM2...	TMOC100-5-12	1.77
2.5	5E2.5ISOTM2...			5I2.5ISOTM2...	TMOC100-5-14	1.87
3.0	5E3.0ISOTM2...			5I3.0ISOTM2...	TMOC100-5-16	1.77
3.5	5E3.5ISOTM2...			5I3.5ISOTM2...	TMOC100-5-16	1.79
4.0	5E4.0ISOTM2...			5I4.0ISOTM2...	TMOC100-5-12	1.73
4.5	5E4.5ISOTM2...			5I4.5ISOTM2...	TMOC100-5-14	1.77
5.0				5I5.0ISOTM028/075...	TMOC100-5-12	1.57

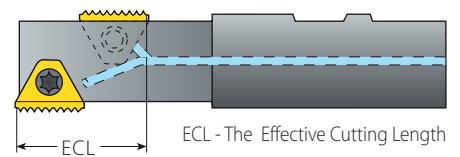

For Le and number of teeth of the above inserts, see the table for standard inserts on pages 254.
For Toolholder information, see page 287.

ISO Metric (con't)

External / Internal

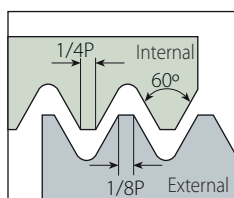

Defined by: R262 (DIN 13)
Tolerance class: 6g/6H

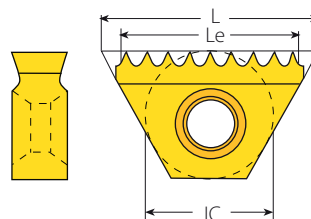
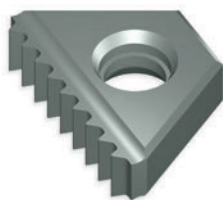

Fine Pitch TM

Fine Pitch TM

Insert Size		Pitch	Ordering Code		Le	Teeth	Toolholder
IC	L Inch	mm	External	Internal	Inch		
6.0mm	.41	0.35	6.0E0.35ISOTMF...	6.0I0.35ISOTMF...	.37	14	TMMC...-6.0
		0.4	6.0E0.4ISOTMF...	6.0I0.4ISOTMF...	.36	12	
		0.45	6.0E0.45ISOTMF...	6.0I0.45ISOTMF...	.37	11	
		0.5	6.0E0.5ISOTMF...		.37	10	
		0.6	6.0E0.6ISOTMF...		.35	8	
		0.7	6.0E0.7ISOTMF...		.36	7	
		0.75	6.0E0.75ISOTMF...		.32	6	
		0.8	6.0E0.8ISOTMF...		.35	6	
1/4"	.43	0.35	2E0.35ISOTM2F...	2I0.35ISOTM2F...	.40	15	TMC...-2 TMSH...-2
		0.4	2E0.4ISOTM2F...	2I0.4ISOTM2F...	.39	13	
		0.45	2E0.45ISOTM2F...	2I0.45ISOTM2F...	.37	11	
		0.5	2E0.5ISOTM2F...		.37	10	
		0.6	2E0.6ISOTM2F...		.40	9	
		0.7	2E0.7ISOTM2F...		.36	7	
		0.8	2E0.8ISOTM2F...		.35	6	
		0.9	2E0.9ISOTM2F...		.39	6	
3/8"	.63	0.35	3E0.35ISOTM2F...	3I0.35ISOTM2F...	.56	21	TMC...-3 TMSH...-3
		0.4	3E0.4ISOTM2F...	3I0.4ISOTM2F...	.58	19	
		0.45	3E0.45ISOTM2F...	3I0.45ISOTM2F...	.58	17	
		0.5	3E0.5ISOTM2F...		.53	14	
		0.6	3E0.6ISOTM2F...		.54	12	
		0.7	3E0.7ISOTM2F...		.58	11	
		0.8	3E0.8ISOTM2F...		.54	9	
		0.9	3E0.9ISOTM2F...		.53	8	

NOTE: Two orbits are required to complete the thread. Fine Pitch TM Inserts produce partial profile thread.

Sample order: **6.0E0.35ISOTMF VBX**

All inserts have 2 cutting edges, except MiniTM (IC 6.0 mm), which has one cutting edge.

For toolholder information, see page 278.

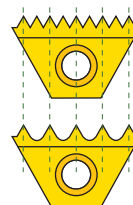

Fine Pitch Threads

Fine pitch threads are threads with small pitches. It is difficult to produce multitooth inserts for small pitches because of the small radius between the teeth. Vargus developed inserts where every second tooth was dropped to enlarge the radius between the teeth.

Important!

- All the fine pitch inserts are partial profile type (as a result of the enlarged radius).

American UN

External / Internal

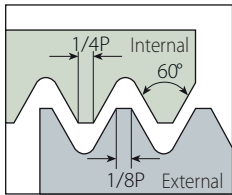

Defined by: ANSI B1.1.74
Tolerance class: Class 2A/2B

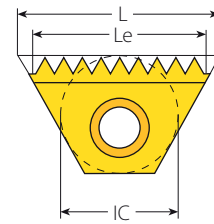
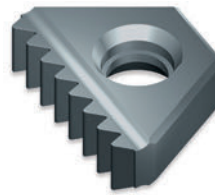

Standard TM

Standard TM

Insert Size		Pitch	Ordering Code		Le	Teeth	Toolholder
IC	L Inch	TPI	External	Internal	Inch		
6.0mm	.41	32		6.0I32UNTM...	.38	12	TMMC...-6.0
		28		6.0I28UNTM...	.36	10	
		24		6.0I24UNTM...	.38	9	
		20		6.0I20UNTM...	.35	7	
		18		6.0I18UNTM...	.33	6	
		16		6.0I16UNTM...	.31	5	
1/4"	.43	48		2I48UNTM2...	.40	19	TMC...-2 TMSH...-2
		40		2I40UNTM2...	.40	16	
		32		2I32UNTM2...	.41	13	
		28	2E28UNTM2...	2I28UNTM2...	.39	11	
		27	2E27UNTM2...	2I27UNTM2...	.41	11	
		24	2E24UNTM2...	2I24UNTM2...	.38	9	
		20	2E20UNTM2...	2I20UNTM2...	.40	8	
		18	2E18UNTM2...	2I18UNTM2...	.39	7	
		16	2E16UNTM2...	2I16UNTM2...	.38	6	
3/8"	.63	40		3I40UNTM2...	.58	23	TMC...-3 TMSH...-3
		32		3I32UNTM2...	.59	19	
		28	3E28UNTM2...	3I28UNTM2...	.57	16	
		27	3E27UNTM2...	3I27UNTM2...	.56	15	
		26	3E26UNTM2...	3I26UNTM2...	.58	15	
		24	3E24UNTM2...	3I24UNTM2...	.58	14	
		20	3E20UNTM2...	3I20UNTM2...	.55	11	
		18	3E18UNTM2...	3I18UNTM2...	.56	10	
		16	3E16UNTM2...	3I16UNTM2...	.56	9	
		14	3E14UNTM2...	3I14UNTM2...	.57	8	
		13	3E13UNTM2...	3I13UNTM2...	.54	6	
		12	3E12UNTM2...	3I12UNTM2...	.58	7	
		11.5	3E11.5UNTM2...	3I11.5UNTM2...	.52	6	
		3/8"B	.87	24	3BE24UNTM2...	3BI24UNTM2...	
20	3BE20UNTM2...			3BI20UNTM2...	.85	17	
18	3BE18UNTM2...			3BI18UNTM2...	.83	15	
16	3BE16UNTM2...			3BI16UNTM2...	.81	13	
14	3BE14UNTM2...			3BI14UNTM2...	.86	12	
13	3BE13UNTM2...			3BI13UNTM2...	.85	11	
		12	3BE12UNTM2...	3BI12UNTM2...	.83	10	

TM Standard

All inserts have 2 cutting edges, except Mini TM (IC 6.0 mm), which has one cutting edge.
For toolholder information, see page 278.

American UN (con't)

External / Internal

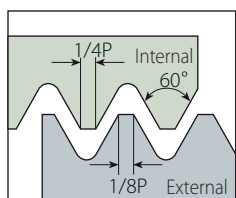

Defined by: ANSI B1.1.74
Tolerance class: Class 2A/2B

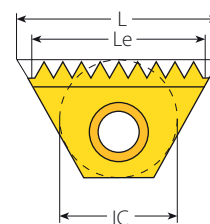
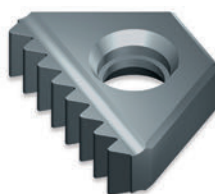

Standard TM

Standard TM

Insert Size		Pitch	Ordering Code		Le	Teeth	Toolholder
IC	L Inch	TPI	External	Internal	Inch		
5/8"	1.06	24	5E24UNTM2...	5I24UNTM2...	1.00	24	TMC.-5 TMSH.-5
		20	5E20UNTM2...	5I20UNTM2...	1.00	20	
		18	5E18UNTM2...	5I18UNTM2...	1.00	18	
		16	5E16UNTM2...	5I16UNTM2...	1.00	16	
		14	5E14UNTM2...	5I14UNTM2...	1.00	14	
		13	5E13UNTM2...	5I13UNTM2...	1.00	13	
		12	5E12UNTM2...	5I12UNTM2...	1.00	12	
		11.5	5E11.5UNTM2...	5I11.5UNTM2...	0.96	11	
		11	5E11UNTM2...	5I11UNTM2...	1.00	11	
		10	5E10UNTM2...		0.90	9	
		10		5I10UNTM2...	1.00	10	
		9	5E9UNTM2...	5I9UNTM2...	0.89	8	
		8	5E8UNTM2...	5I8UNTM2...	0.88	7	
		7	5E7UNTM2...		0.86	6	
		7		5I7UNTM2...	1.00	7	
		6	5E6UNTM2...		0.83	5	
6		5I6UNTM2...	1.00	6			
3/4"B	1.52	6	6BE6UNTM2...	6BI6UNTM2...	1.33	8	TMC.-6B TMSH.-6B
		5	6BE5UNTM2...	6BI5UNTM2...	1.20	6	
		4.5	6BE4.5UNTM2...	6BI4.5UNTM2...	1.33	6	
		4	6BE4UNTM2...	6BI4UNTM2...	1.25	5	

TM Standard

All inserts have 2 cutting edges, except MiniTM (IC 6.0 mm), which has one cutting edge. For toolholder information, see page 278.

American UN (con't)

Internal

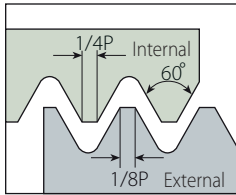

Defined by: ANSI B1.1.74
Tolerance class: Class 2A/2B

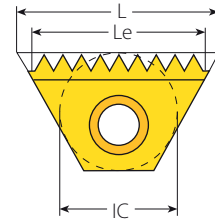
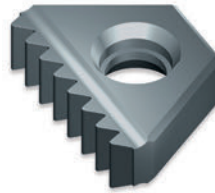

Coarse Pitch TM

Coarse Pitch TM

Thread	Insert Size		Ordering Code	Cutting Edge	Le	Teeth	Toolholder	Bore Dia. Range
	IC	L Inch						
7/16"-20UNF	6.0mm	.41	6.0I20UNTM028/012...	1	.35	7	TMMC050-6.0	.38 - .45
7/16"-20UNF			6.0I20UNTM028/012...	1	.35	7	TMMC075-6.0	.38 - .45
7/16"-16UN			6.0I16UNTM028/014...	1	.31	5	TMMC050-6.0	.37 - .56
7/16"-16UN			6.0I16UNTM028/014...	1	.31	5	TMMC075-6.0	.37 - .56
7/16"-14UNC			6.0I14UNTM028/013...	1	.36	5	TMMC075-6.0-124/203	.36 - .39
1/2"-13UNC	1/4"	.43	2I13UNTM028/015...	1	.38	5	TMC075-2-124/205	.41 - .77
1/2"-16UN	6.0mm	.41	6.0I16UNTM028/014...	1	.31	5	TMMC050-6.0	.37 - .56
1/2"-16UN			6.0I16UNTM028/014...	1	.31	5	TMMC075-6.0	.37 - .56
9/16"-12UNC	1/4"	.43	2I12UNTM028/016...	1	.33	4	TMC075-2-124/205	.47 - .61
9/16"-18UNF			2I18UNTM028/017...	2	.39	7	TMC050-2	.50 - .57
9/16"-18UNF			2I18UNTM028/017...	2	.39	7	TMC075-2	.50 - .57
9/16"-16UN	6.0mm	.41	6.0I16UNTM028/014...	1	.31	5	TMMC050-6.0	.37 - .56
9/16"-16UN			6.0I16UNTM028/014...	1	.31	5	TMMC075-6.0	.37 - .56
5/8"-11UNC	1/4"	.43	2I11UNTM028/018...	1	.36	4	TMC075-2-124/206	.52 - .73
5/8"-12UN			2I12UNTM028/016...	1	.33	4	TMC075-2-124/205	.47 - .61
5/8"-16UN	6.0mm	.41	6.0I16UNTM028/014...	1	.31	5	TMMC050-6.0	.37 - .56
5/8"-16UN			6.0I16UNTM028/014...	1	.31	5	TMMC075-6.0	.37 - .56
11/16"-12UN	1/4"	.43	2I12UNTM028/016...	1	.33	4	TMC075-2-124/205	.47 - .61
3/4"-10UNC	3/8"	.63	3I10UNTM028/019...	1	.50	5	TMC0625-3-124/201	.64 - 1.24
3/4"-12UN			3I12UNTM028/020...	2	.58	7	TMNC0625-3	.66 - .72
13/16"-12UN			3I12UNTM028/020...	2	.58	7	TMC0625-3	.72 - .77
7/8"-9UNC	1/2"	.87	4I9UNTM028/021...	1	.67	6	TMC100-4-124/202	.75 - 1.28

American UN (con't)

Internal

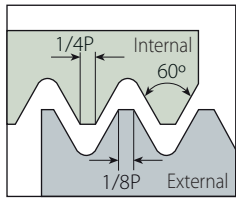

Defined by: ANSI B1.1.74
Tolerance class: Class 2A/2B

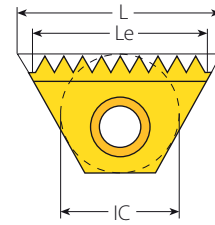
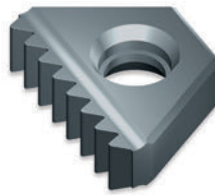

Coarse Pitch TM

Coarse Pitch TM

Thread	Insert Size		Ordering Code	Cutting Edge	Le	Teeth	Toolholder	Bore Dia. Range
	IC	L Inch						
1"-8UNC	1/2"	.87	4I8UNTM028/022...	1	.75	6	TMC100 - 4 124/207	.86 - 1.11
1 1/16"-8UN			4I8UNTM028/022...	1	.75	6	TMC100-4 124/207	.86 - 1.11
1 1/8"-7UNC			4I7UNTM028/023...	1	.71	5	TMC100-4 124/202	.97 - 1.41
1 1/8"-8UN			4I8UNTM028/022...	1	.75	6	TMC100-4 124/207	.86 - 1.11
1 3/16"-8UN			4I8UNTM028/022...	1	.75	6	TMC100-4 124/207	.86 - 1.11
1 1/4"-7UNC			4I7UNTM028/023...	1	.71	5	TMC100-4 124/202	.97 - 1.41
1 1/4"-8UN	5/8"	1.06	5I8UNTM028/024...	2	.88	7	TMC100-5 124/204	1.11 - 1.30
1 5/16"-8UN			5I8UNTM028/024...	2	.88	7	TMC100-5 124/204	1.11 - 1.30
1 3/8"-6UNC			5I6UNTM028/025...	2	1.00	6	TMC100-5 124/204	1.19 - 1.44
1 3/8"-8UN			5I8UNTM028/024...	2	.88	7	TMC100-5 124/204	1.11 - 1.30
1 7/16"-6UN			5I6UNTM028/025...	2	1.00	6	TMC100-5 124/204	1.19 - 1.44
1 7/16"-8UN			5I8UNTM028/024...	2	.88	7	TMC100-5	1.30 - 1.54
1 1/2"-6UNC			5I6UNTM028/025...	2	1.00	6	TMC100-5 124/204	1.19 - 1.44
1 1/2"-8UN			5I8UNTM028/024...	2	.88	7	TMC100-5	1.30 - 1.54
1 9/16"-6UN			5I6UNTM028/025...	2	1.00	6	TMC100-5 124/204	1.19 - 1.44
1 9/16"-8UN			5I8UNTM028/024...	2	.88	7	TMC100-5	1.30 - 1.54
1 5/8"-6UN			5I6UNTM028/025...	2	1.00	6	TMC100-5	1.44 - 1.77
1 5/8"-8UN			5I8UNTM028/024...	2	.88	7	TMC100-5	1.30 - 1.54
1 11/16"-6UN			5I6UNTM028/025...	2	1.00	6	TMC100-5	1.44 - 1.77
1 3/4"-5UNC			5I5UNTM028/077...	2	.80	4	TMC100-5	1.53 - ∞
1 3/4"-6UN			5I6UNTM028/025...	2	1.00	6	TMC100-5	1.44 - 1.77
1 13/16"-6UN			5I6UNTM028/025...	2	1.00	6	TMC100-5	1.44 - 1.77
1 7/8"-6UN			5I6UNTM028/025...	2	1.00	6	TMC100-5	1.44 - 1.77
1 15/16"-6UN			5I6UNTM028/025...	2	1.00	6	TMC100-5	1.44 - 1.77

TM Standard

For toolholder information, see page 282.

American UN (con't)

External / Internal

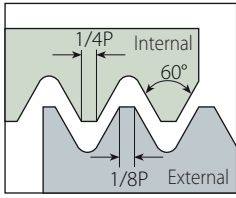

Defined by: ANSI B1.1.74
Tolerance class: Class 2A/2B

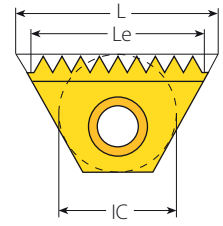
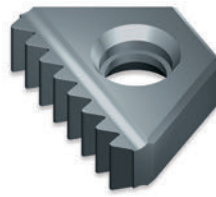

Standard TM

Standard TM Inserts for TMO Toolholders

Insert Size		Pitch	Ordering Code			ECL
IC	L Inch	TPI	External	Internal	Toolholder	Inch
1/4"	.43	48		2I48UNTM2...	TMOC075-2-1	.77
		48		2I48UNTM2...	TMOC075-2-2	.73
		48		2I48UNTM2...	TMOC075-2-9	.75
		32		2I32UNTM2...	TMOC075-2-1	.78
		28	2E28UNTM2...	2I28UNTM2...	TMOC075-2-3	.68
		24	2E24UNTM2...	2I24UNTM2...	TMOC075-2-2	.71
		20	2E20UNTM2...	2I20UNTM2...	TMOC075-2-4	.75
		18	2E18UNTM2...	2I18UNTM2...	TMOC075-2-2	.72
		16	2E16UNTM2...	2I16UNTM2...	TMOC075-2-1	.75
		14	2E14UNTM2...	2I14UNTM2...	TMOC075-2-3	.64
3/8"	.63	32		3I32UNTM2...	TMOC075-3-3	1.09
		32		3I32UNTM2...	TMOC075-3-11	1.13
		28	3E28UNTM2...	3I28UNTM2...	TMOC075-3-3	1.07
		27	3E27UNTM2...	3I27UNTM2...	TMOC075-3-4	1.07
		24	3E24UNTM2...	3I24UNTM2...	TMOC075-3-6	1.08
		20	3E20UNTM2...	3I20UNTM2...	TMOC075-3-6	1.05
		18	3E18UNTM2...	3I18UNTM2...	TMOC075-3-6	1.06
		16	3E16UNTM2...	3I16UNTM2...	TMOC075-3-6	1.06
		14	3E14UNTM2...	3I14UNTM2...	TMOC075-3-6	1.07
		13	3E13UNTM2...	3I13UNTM2...	TMOC075-3-2	1.00
		12	3E12UNTM2...	3I12UNTM2...	TMOC075-3-6	1.08
		11.5	3E11.5UNTM2...	3I11.5UNTM2...	TMOC075-3-5	.96

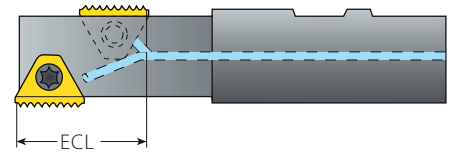

ECL - The Effective Cutting Length

For Le and number of teeth of the above inserts, see the table for standard inserts on pages 254.
For toolholder information, see page 287.

American UN (con't)

External / Internal

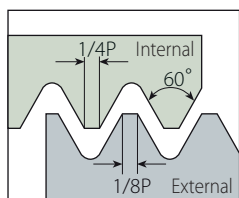

Defined by: ANSI B1.1.74
Tolerance class: Class 2A/2B

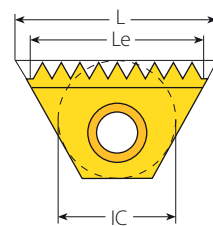
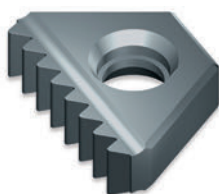

Standard TM

Standard TM Inserts for TMO Toolholders

Insert Size		Pitch	Ordering Code			ECL
IC	L Inch	TPI	External	Internal	Toolholder	Inch
5/8"	1.06	24	5E24UNTM2..	5I24UNTM2..	TMOC100-5-1	2.00
		24	5E24UNTM2...	5I24UNTM2...	TMOC100-5-2	1.83
		20	5E20UNTM2...	5I20UNTM2...	TMOC100-5-1	2.00
		18	5E18UNTM2...	5I18UNTM2...	TMOC100-5-1	2.00
		18	5E18UNTM2...	5I18UNTM2...	TMOC100-5-2	1.83
		16	5E16UNTM2...	5I16UNTM2...	TMOC100-5-3	1.88
		14	5E14UNTM2...	5I14UNTM2...	TMOC100-5-1	2.00
		14	5E14UNTM2...	5I14UNTM2...	TMOC100-5-4	1.86
		13	5E13UNTM2...	5I13UNTM2...	TMOC100-5-1	2.00
		12	5E12UNTM2...	5I12UNTM2...	TMOC100-5-2	1.83
		12	5E12UNTM2...		TMOC100-5-1	2.00
		11.5	5E11.5UNTM2...	5I11.5UNTM2...	TMOC100-5-5	1.83
		11	5E11UNTM2...	5I11UNTM2...	TMOC100-5-6	1.91
		11		5I11UNTM2...	TMOC100-5-1	1.82
		10	5E10UNTM2...		TMOC100-5-7	1.70
		10		5I10UNTM2...	TMOC100-5-7	1.80
		9	5E9UNTM2...	5I9UNTM2...	TMOC100-5-8	1.78
		8	5E8UNTM2...	5I8UNTM2...	TMOC100-5-9	1.75
		7	5E7UNTM2...		TMOC100-5-10	1.71
		7		5I7UNTM2...	TMOC100-5-10	1.86
6	5E6UNTM2...		TMOC100-5-2	1.67		
6		5I6UNTM2...	TMOC100-5-2	1.83		
5		5I5UNTM028/077...	TMOC100-5-7	1.60		

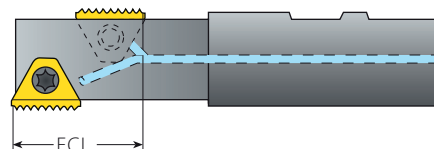

ECL - The Effective Cutting Length

For Le and number of teeth of the above inserts, see the table for standard inserts on pages 254.
For toolholder information, see page 287.

American UN (con't)

External / Internal

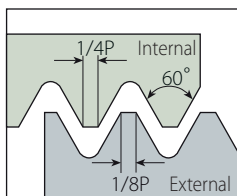

Defined by: ANSI B1.1.74
Tolerance class: Class 2A/2B

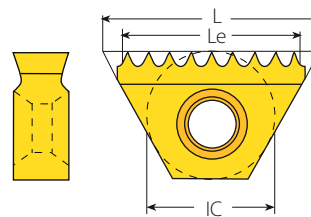
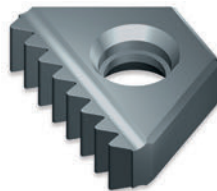

Fine Pitch TM

Fine Pitch TM

Insert Size		Pitch	Ordering Code		Le	Teeth	Toolholder
IC	L Inch	TPI	External	Internal	Inch		
6.0mm	.41	80	6.0E80UNTMF...	6.0I80UNTMF...	.39	16	TMMC...-6.0
		72	6.0E72UNTMF...	6.0I72UNTMF...	.38	14	
		64	6.0E64UNTMF...	6.0I64UNTMF...	.36	12	
		56	6.0E56UNTMF...	6.0I56UNTMF...	.38	11	
		48	6.0E48UNTMF...		.35	9	
		44	6.0E44UNTMF...		.34	8	
		40	6.0E40UNTMF...		.33	7	
		36	6.0E36UNTMF...		.36	7	
1/4"	.43	80	2E80UNTM2F...	2I80UNTM2F...	.39	16	TMC...-2 TMSH...-2
		72	2E72UNTM2F...	2I72UNTM2F...	.40	15	
		64	2E64UNTM2F...	2I64UNTM2F...	.39	13	
		56	2E56UNTM2F...	2I56UNTM2F...	.38	11	
		48	2E48UNTM2F...		.40	10	
		44	2E44UNTM2F...		.39	9	
		40	2E40UNTM2F...		.38	8	
		36	2E36UNTM2F...		.36	7	
3/8"	.63	80	3E80UNTM2F...	3I80UNTM2F...	.56	23	TMC...-3 TMSH...-3
		72	3E72UNTM2F...	3I72UNTM2F...	.57	21	
		64	3E64UNTM2F...	3I64UNTM2F...	.58	19	
		56	3E56UNTM2F...	3I56UNTM2F...	.55	16	
		48	3E48UNTM2F...		.56	14	
		44	3E44UNTM2F...		.57	13	
		40	3E40UNTM2F...		.58	12	
		36	3E36UNTM2F...		.58	11	
		32	3E32UNTM2F...		.53	9	

NOTE: Two orbits are required to complete the thread. Fine Pitch TM Inserts produce partial profile thread.

Sample order: **6.0E80UNTMF VBX**

All inserts have 2 cutting edges, except MiniTM (IC 6.0 mm), which has one cutting edge.

For toolholder information, see page 278.

Fine Pitch Threads

Fine pitch threads are threads with small pitches. It is difficult to produce multitooth inserts for small pitches because of the small radius between the teeth. Vargus developed inserts where every second tooth was dropped to enlarge the radius between the teeth.

Important!

- All the fine pitch inserts are partial profile type (as a result of the enlarged radius).

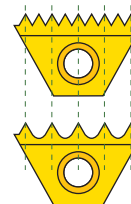

External / Internal

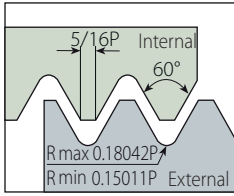

Defined by: MIL-S-8879C
Tolerance class: 3A/3B

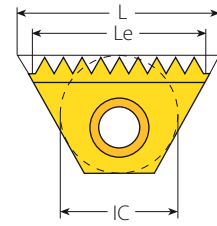
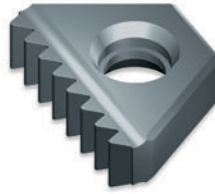

Standard TM

Standard TM

Insert Size		Pitch	Ordering Code		Le	Teeth	Toolholder
IC	L Inch	TPI	External	Internal	Inch		
6.0mm	.41	24		6.0I24UNJTM...	.38	9	TMMC...-6.0
		20		6.0I20UNJTM...	.35	7	
		18		6.0I18UNJTM...	.33	6	
		16		6.0I16UNJTM...	.31	5	
1/4"	.43	24	2E24UNJTM2...	2I24UNJTM2...	.38	9	TMC...-2 TMSH...-2
		20	2E20UNJTM2...	2I20UNJTM2...	.40	8	
		18		2I18UNJTM2...	.39	7	
		16	2E16UNJTM2...	2I16UNJTM2...	.38	6	
		14	2E14UNJTM2...	2I14UNJTM2...	.36	5	
3/8"	.63	24	3E24UNJTM2...	3I24UNJTM2...	.58	14	TMC...-3 TMSH...-3
		20	3E20UNJTM2...	3I20UNJTM2...	.55	11	
		18	3E18UNJTM2...	3I18UNJTM2...	.56	10	
		16	3E16UNJTM2...	3I16UNJTM2...	.56	9	
		14	3E14UNJTM2...	3I14UNJTM2...	.57	8	
		13	3E13UNJTM2...		.54	7	
5/8"	1.06	12	3E12UNJTM2...	3I12UNJTM2...	.58	7	TMC...-5 TMSH...-5
		16	5E16UNJTM2...	5I16UNJTM2...	1.00	16	
		12	5E12UNJTM2...	5I12UNJTM2...	1.00	12	
		11	5E11UNJTM2...	5I11UNJTM2...	1.00	11	

All inserts have 2 cutting edges, except MiniTM (IC 6.0 mm), which has one cutting edge.
For toolholder information, see page 278.

Whitworth for BSW, BSP

External / Internal

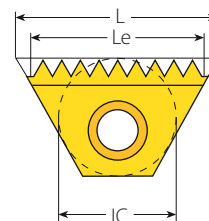
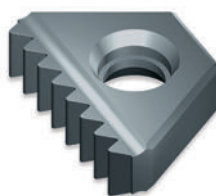
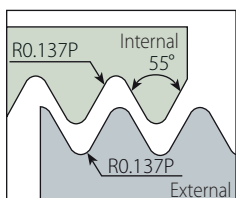

BSW Defined by: B.S.84:1956, DIN 259, ISO228/1:1982
 BSP Defined by: B.S.2779:1956
 Tolerance class: BSW-Medium class A, BSP-Medium class

Standard TM

Standard TM

Insert Size		Pitch	Ordering Code	Le	Teeth	Toolholder
IC	L Inch	TPI	External + Internal	Inch		
6.0mm	.41	28	6.0EI28WTM...	.36	10	TMMC..-6.0
		26	6.0EI26WTM...	.35	9	
		24	6.0EI24WTM...	.38	9	
		20	6.0EI20WTM...	.35	7	
		19	6.0EI19WTM...	.37	7	
1/4"	.43	28	2EI28WTM2...	.39	11	TMC..-2 TMSH..-2
		26	2EI26WTM2...	.38	10	
		24	2EI24WTM2...	.38	9	
		20	2EI20WTM2...	.40	8	
		19	2EI19WTM2...	.37	7	
3/8"	.63	14	2EI14WTM2...	.36	5	TMC..-3 TMSH..-3
		26	3EI26WTM2...	.58	15	
		24	3EI24WTM2...	.58	14	
		20	3EI20WTM2...	.55	11	
		19	3EI19WTM2...	.58	11	
		18	3EI18WTM2...	.56	10	
		16	3EI16WTM2...	.56	9	
		14	3EI14WTM2...	.57	8	
3/8"B	.87	12	3EI12WTM2...	.58	7	TMC..-3B TMSH..-3B
		11	3EI11WTM2...	.55	6	
		24	3BEI24WTM2...	.83	20	
		20	3BEI20WTM2...	.85	17	
		19	3BEI19WTM2...	.84	16	
		18	3BEI18WTM2...	.83	15	
		16	3BEI16WTM2...	.81	13	
5/8"	1.06	14	3BEI14WTM2...	.86	12	TMC..-5 TMSH..-5
		12	3BEI12WTM2...	.83	10	
		16	5EI16WTM2...	1.00	16	
		14	5EI14WTM2...	1.00	14	
		12	5EI12WTM2...	.92	11	
		11	5EI11WTM2...	.91	10	
		10	5EI10WTM2...	1.00	10	
		9	5EI9WTM2...	.89	8	
3/4"B	1.52	8	5EI8WTM2...	.88	7	TMC..-6B TMSH..-6B
		7	5EI7WTM2...	.86	6	
		6	5EI6WTM2...	.83	5	
		11	6BEI11WTM2...	1.36	15	
3/4"	1.52	6	6BEI6WTM2...	1.33	8	TMC..-6B TMSH..-6B
		5	6BEI5WTM2...	1.20	6	
		4.5	6BEI4.5WTM2...	1.33	6	

All inserts have 2 cutting edges, except MiniTM (IC 6.0 mm) which has one cutting edge.
 For toolholder information, see page 278.

Whitworth for BSW only (con't)

Internal

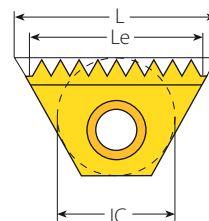
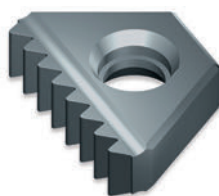
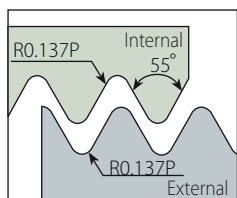

Defined by: B.S.84:1956, DIN259, ISO228/1:1982
Tolerance class: Medium class A

Coarse Pitch TM

Coarse Pitch TM

Thread	Insert Size		Ordering Code	Cutting Edge	Le	Teeth	Toolholder	Bore Dia. Range
Inch	IC	L Inch	Internal		Inch		Inch	
7/16"-18	6.0mm	.41	6.0118WTM028/035...	1	.33	6	TMMC050-6.0	.37 - .56
7/16"-18			6.0118WTM028/035...	1	.33	6	TMMC075-6.0	.37 - .56
7/16"-26			6.0126WTM028/036...	1	.35	9	TMMC050-6.0	.39 - .41
7/16"-26			6.0126WTM028/036...	1	.35	9	TMMC075-6.0	.39 - .41
1/2"-16	1/4"	.43	2116WTM028/051...	1	.38	6	TMC075-2 124/205	.42 - .48
1/2"-20	6.0mm	.41	6.0120WTM028/037...	1	.35	7	TMMC050-6.0	.43 - .45
1/2"-20			6.0120WTM028/037...	1	.35	7	TMMC075-6.0	.43 - .45
9/16"-16	1/4"	.43	2116WTM028/038...	2	.38	6	TMC050-2	.48 - .73
9/16"-16			2116WTM028/038...	2	.38	6	TMC075-2	.48 - .73
5/8"-14			2114WTM028/039...	1	.36	5	TMC075-2 124/206	.53 - .75
11/16"-14			2114WTM028/039...	1	.36	5	TMC075-2 124/206	.53 - .75
11/16"-16			2116WTM028/038...	2	.38	6	TMC050-2	.48 - .73
11/16"-16			2116WTM028/038...	2	.38	6	TMC075-2	.48 - .73
3/4"-12	3/8"	.63	3112WTM028/040...	1	.58	7	TMC0625-3 124/201	.64 - .70
3/4"-16	1/4"	.43	2116WTM028/038...	2	.38	6	TMC050-2	.48 - .73
3/4"-16			2116WTM028/038...	2	.38	6	TMC075-2	.48 - .73
13/16"-12	3/8"	.63	3112WTM028/041...	2	.58	7	TMC0625-3	.70 - .83
7/8"-9	1/2"	.87	419WTM028/042...	1	.67	6	TMC100-4 124/202	.73 - 1.28
7/8"-11			4111WTM028/043...	1	.73	8	TMC100-4 124/202	.76 - .87
15/16"-12	3/8"	.63	3112WTM028/041...	2	.58	7	TMC075-3	.83 - 1.20
1"-8	1/2"	.87	418WTM028/044...	1	.63	5	TMC100-4 124/202	.84 - 1.02
1"-10			4110WTM028/045...	1	.70	7	TMC100-4 124/202	.87 - 1.24
1"-12	3/8"	.63	3112WTM028/041...	2	.58	7	TMC075-3	.83 - 1.20
1 1/16"-12			3112WTM028/041...	2	.58	7	TMC075-3	.83 - 1.20
1 1/8"-7	5/8"	1.06	517WTM028/046...	1	.86	6	TMC100-5 124/208	.94 - 1.07
1 1/8"-9	1/2"	.87	419WTM028/042...	1	.67	6	TMC100-4 124/202	.73 - 1.28
1 1/8"-12	3/8"	.63	3112WTM028/041...	2	.58	7	TMC075-3	.83 - 1.20
1 3/16"-8	5/8"	1.06	518WTM028/047...	2	.88	7	TMC100-5 124/204	1.02 - 1.28
1 3/16"-12	3/8"	.63	3112WTM028/041...	2	.58	7	TMC075-3	.83 - 1.20
1 1/4"-7	5/8"	1.06	517WTM028/048...	2	.86	6	TMC100-5 124/204	.85 - 1.41
1 1/4"-9	1/2"	.87	419WTM028/042...	1	.67	6	TMC100-4 124/202	.73 - 1.28
1 1/4"-12	3/8"	.63	3112WTM028/041...	2	.58	7	TMC075-3	.83 - 1.20
1 5/16"-6	5/8"	1.06	516WTM028/049...	2	.83	5	TMC100-5 124/204	1.10 - 1.28
1 5/16"-8			518WTM028/047...	2	.88	7	TMC100-5 124/204	1.02 - 1.28

For toolholder information, see page 282.

Whitworth for BSW only (con't)

Internal

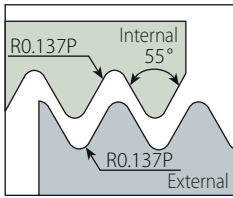

Defined by: B.S.84:1956, DIN259, ISO228/1:1982
Tolerance class: Medium class A

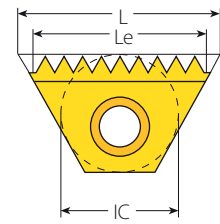
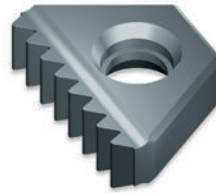

Coarse Pitch TM Inserts

Coarse Pitch TM

Thread	Insert Size		Ordering Code	Cutting Edge	Le	Teeth	Toolholder	Bore Dia. Range		
	IC	L Inch								
1 5/16"-12	3/8"	.63	3I12WTM028/041...	2	.58	7	TMC075-3	.83 - 1.20		
1 3/8"-8			5I8WTM028/047...	2	.88	7	TMC100-5-124/204	1.02 - 1.28		
1 3/8"-6			5I6WTM028/049...	2	.83	5	TMC100-5-124/204	1.10 - 1.28		
1 3/8"-12			5I12WTM028/050...	2	.92	11	TMC100-5	1.27 - 1.36		
1.4-6			5I6WTM028/049...	2	.83	5	TMC100-5-124/204	1.10 - 1.28		
1.4-8			5I8WTM028/047...	2	.88	7	TMC100-5-124/204	1.02 - 1.28		
1.4-12			5I12WTM028/050...	2	.92	11	TMC100-5	1.27 - 1.36		
1 7/16"-6			5/8"	1.06	5I6WTM028/049...	2	.83	5	TMC100-5-124/204	1.10 - 1.28
1 7/16"-8					5I8WTM028/047...	2	.88	7	TMC100-5	1.28 - 1.54
1 7/16"-12					5I12WTM028/050...	2	.92	11	TMC100-5	1.27 - 1.36
1 1/2"-6					5I6WTM028/049...	2	.83	5	TMC100-5-124/204	1.10 - 1.29
1 1/2"-8					5I8WTM028/047...	2	.88	7	TMC100-5	1.28 - 1.54
1.6-6					5I6WTM028/049...	2	.83	5	TMC100-5	1.28 - 1.52
1.6-8					5I8WTM028/047...	2	.88	7	TMC100-5	1.28 - 1.54
1 5/8"-8					5I8WTM028/047...	2	.88	7	TMC100-5	1.28 - 1.54
1 5/8"-6					5I6WTM028/049...	2	.83	5	TMC100-5	1.28 - 1.52
1 3/4"-7					5I7WTM028/048...	2	.86	6	TMC100-5	1.57 - 1.65
1 7/8"-6					5I6 WTM028/049...	2	.83	5	TMC125-5	1.66 - 1.77
1.9-6					5I6 WTM028/049...	2	.83	5	TMC125-5	1.66 - 1.77

For toolholder information, see page 282.

Whitworth for BSW only (con't)

External / Internal

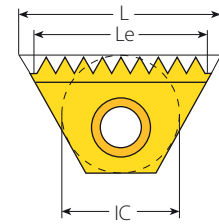
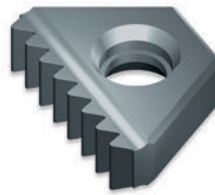
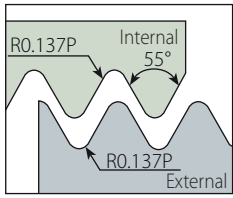

Defined by: B.S.84:1956, DIN259, ISO228/1:1982
Tolerance class: Medium class A

Standard TM

Standard TM Inserts for TMO Toolholders

Insert Size		Pitch	Ordering Code		ECL
IC	L Inch	TPI	External + Internal	Toolholder	Inch
1/4"	.43	28	2EI28WTM2...	TMOC075-2-3	.68
		26	2EI26WTM2...	TMOC075-2-5	.73
		24	2EI24WTM2...	TMOC075-2-2	.71
		20	2EI20WTM2...	TMOC075-2-6	.75
		19	2EI19WTM2...	TMOC075-2-7	.68
		14	2EI14WTM2...	TMOC075-2-3	.64
3/8"	.63	26	3EI26WTM2...	TMOC075-3-2	1.08
		26	3EI26WTM2...	TMOC075-3-6	1.04
		24	3EI24WTM2...	TMOC075-3-7	1.12
		20	3EI20WTM2...	TMOC075-3-6	1.05
		19	3EI19WTM2...	TMOC075-3-8	1.11
		18	3EI18WTM2...	TMOC075-3-6	1.06
		16	3EI16WTM2...	TMOC075-3-6	1.06
		14	3EI14WTM2...	TMOC075-3-6	1.07
		12	3EI12WTM2...	TMOC075-3-6	1.08
5/8"	1.06	11	3EI11WTM2...	TMOC075-3-9	1.09
		16	5EI16WTM2...	TMOC100-5-3	1.88
		14	5EI14WTM2...	TMOC100-5-1	2.00
		14	5EI14WTM2...	TMOC100-5-4	1.86
		12	5EI12WTM2...	TMOC100-5-2	1.75
		11	5EI11WTM2...	TMOC100-5-6	1.82
		10	5EI10WTM2...	TMOC100-5-7	1.8
		9	5EI9WTM2...	TMOC100-5-8	1.78
		8	5EI8WTM2...	TMOC100-5-9	1.75
		7	5EI7WTM2...	TMOC100-5-4	1.71
		6	5EI6WTM2...	TMOC100-5-11	1.67

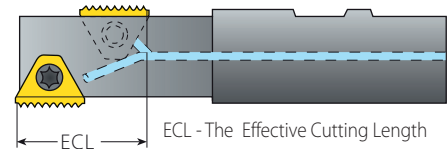

For Le and number of teeth of the above inserts, see the table for standard inserts on page 254.
For toolholder information see page 278.

NPT

External / Internal

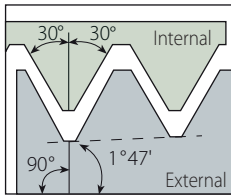

Defined by: USAS B2.1:1968
Tolerance class: Standard NPT

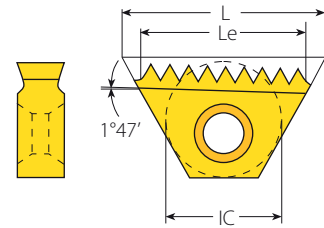
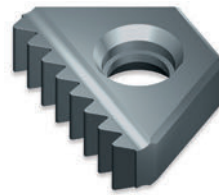

Standard TM

Standard TM

Insert Size		Pitch	Ordering Code	Le	Teeth	Toolholder	
IC	L Inch	TPI	External + Internal	Inch		RH	LH
3/8"	.63	18	3E18NPT-TM2... *	.56	10		
		14	3E14NPT-TM2...	.57	8	TMNC...-3	TMNC...-3LH
		11.5	3E11.5NPT-TM2...	.52	6		
3/8"B	.87	14	3BE14NPT-TM2...	.86	12	BTMNC...-3B	BTMNC...-3BLH
		11.5	3BE11.5NPT-TM2... **	.78	9		
5/8"	1.06	11.5	5E11.5NPT-TM2...	.96	11	TM.C...-5	TM.C...-5LH
		8	5E18NPT-TM2...	.88	7	TMNC...-5	TMNC...-5LH
3/4"B	1.52	11.5	6BE11.5NPT-TM2...	1.39	16	TMC...-6B	TMC...-6BLH
		8	6BE18NPT-TM2...	1.25	10		

* For external thread only.
To thread with insert cutting edge marked "L", use LH toolholders.
For toolholder information, see page 284.

** Single sided insert - RH only.

TM Standard

NPT

Internal

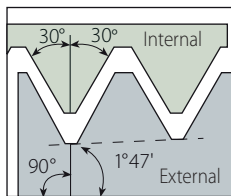

Defined by: USAS B2.1:1968
Tolerance class: Standard NPT

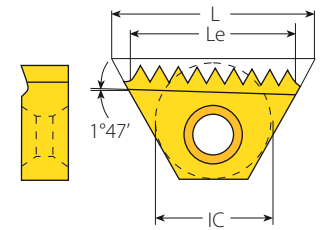

Coarse Pitch TM

Coarse Pitch TM

Thread	Insert Size		Ordering Code	Cutting Edge	Le	Teeth	Toolholder
Inch	IC	L Inch	Internal		Inch		
1/4"-18	1/4"	.43	2I18NPT-TM028/074...	1	.39	7	TMC0752-2-124/209
3/8"-18			2I18NPT-TM028/074...	1	.39	7	TMC0752-2-124/209

For toolholder information, see page 284.

NPTF (Dry Seal)

External / Internal

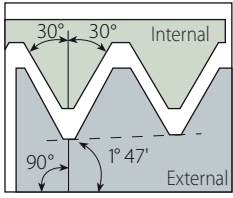

Defined by: ANSI 1.20.3-1976
Tolerance class: Standard NPTF

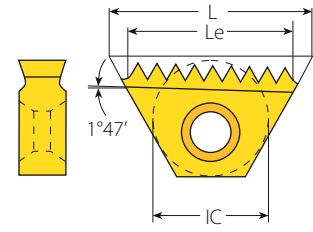
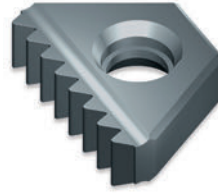

Standard TM

Standard TM

Insert Size		Pitch	Ordering Code	Le	Teeth	Toolholder	
IC	L Inch	TPI	External + Internal	Inch		RH	LH
3/8"	.63	14	3EI14NPTFTM2...	.57	8	TMNC..-3	TMNC..-3LH
		11.5	3EI11.5NPTFTM2...	.52	6		
3/8"B	.87	14	3BEI14NPTFTM2...	.86	12	BTMNC..-3B	BTMNC..-3BLH
		11.5	3BEI11.5NPTFTM2...	.78	9		
5/8"	1.06	11.5	5EI11.5NPTFTM2...	.96	11	TM.C..-5	TM.C..-5LH
		8	5EI8NPTFTM2...	.88	7		
3/4"B	1.52	11.5	6BEI11.5NPTFTM2...	1.39	16	TMC..-6B	TMC..-6BLH
		8	6BEI8NPTFTM2...	1.25	10		

To thread with insert cutting edge marked "L", use LH toolholders.
For toolholder information, see page 284.

TM Standard

NPTF (Dry Seal)

Internal

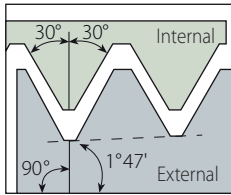

Defined by: ANSI 1.20.3-1976
Tolerance class: Standard NPTF

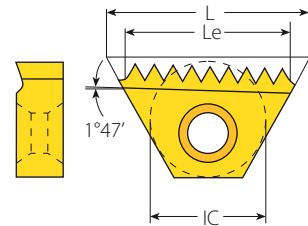

Coarse Pitch TM

Coarse Pitch TM

Thread	Insert Size		Ordering Code	Cutting Edge	Le	Teeth	Toolholder
Inch	IC	L Inch	Internal		Inch		
1/4"-18	1/4"	.43	2I18NPTFTM028/078...	1	.39	7	TMC075-2-124/209
3/8"-18			2I18NPTFTM028/078...	1	.39	7	TMC075-2-124/209

For toolholder information, see page 284.

NPS

External / Internal

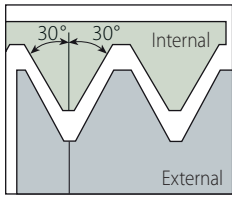

Defined by: USA NBS H28 (1957)
Tolerance class: Standard NPS

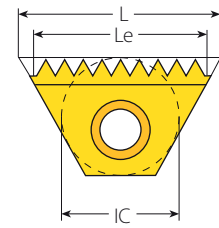
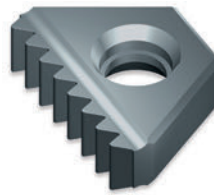

Standard TM

Standard TM

Insert Size		Pitch	Ordering Code	Le	Teeth	Nominal Thread Size	
IC	L Inch	TPI	External + Internal	Inch			Toolholder
3/8"	.63	14	3EI14NPSTM2...	.57	8	1/2"	TMNC0625-3
		14	3EI14NPSTM2...	.57	8	3/4"	TMNC075-3
		11.5	3EI11.5NPSTM2...	.52	6	1", 1 1/4"	TMNC075-3
3/8"B	.87	11.5	3BEI11.5NPSTM2...*	.78	9	1", 1 1/4"	BTMNC075-3B
5/8"	1.06	11.5	5EI11.5NPSTM2...	.96	11	1 1/2", 2"	TMC100-5
		8	5EI8NPSTM2...	.88	7	2 1/2" & larger	TMC125-5

* One cutting edge.
All inserts have 2 cutting edges.
For toolholder information, see page 278.

BSPT

External / Internal

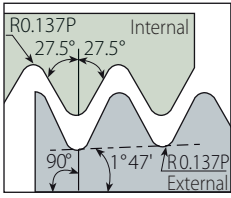

Defined by: B.S. 21:1985
Tolerance class: Standard BSPT

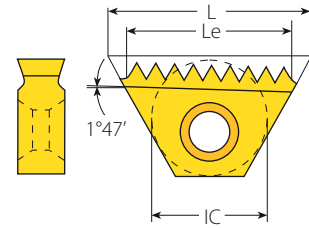
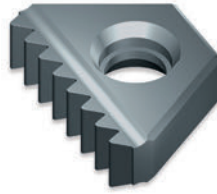

Standard TM

Standard TM

Insert Size		Pitch	Ordering Code	Le	Teeth	Toolholder	
IC	L Inch	TPI	External + Internal	Inch		RH	LH
1/4"	.43	19	2EI19BSPT-TM2...	.37	7	TMC..-2	TMC..-2LH
3/8"	.63	14	3EI14BSPT-TM2...	.57	8	TMNC..-3	TMNC..-3LH
		11	3EI11BSPT-TM2...	.55	6		
5/8"	1.06	11	5EI11BSPT-TM2...	.91	10	TMC..-5	TMC..-5LH

To thread with insert cutting edge marked "L", use a LH toolholder.
For toolholder information, see page 284.

Pg

External / Internal

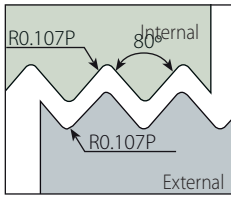

Defined by: DIN 40430
Tolerance class: Standard

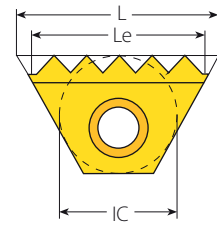
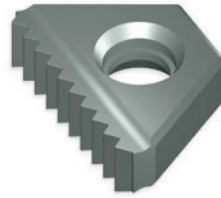

Standard TM

Standard TM

Insert Size		Pitch	Ordering Code	Le	Teeth	Nominal Thread Size	Toolholder
IC	L Inch	TPI	External + Internal	Inch			
6.0mm	.41	20	6.0EI20PGTM...	.35	7	Pg7	TMMC..-6.0
		20	2EI20PGTM2...	.40	8	Pg7	
1/4"	.43	18	2EI18PGTM2...	.39	7	Pg9, Pg11, Pg13.5, Pg16	TMC..-2
		16	2EI16PGTM2...	.38	6	Pg21, Pg29, Pg36, Pg42, Pg48	TMSH..-2
3/8"	.63	20	3EI20PGTM2...	.55	11	Pg7	TMC..-3
		18	3EI18PGTM2...	.56	10	Pg9, Pg11, Pg13.5, Pg16	TMSH..-3
5/8"	1.06	16	3EI16PGTM2...	.56	9	Pg21, Pg29, Pg36, Pg42, Pg48	
		16	5EI16PGTM2...	1.00	16	Pg21, Pg29, Pg36, Pg42, Pg48	TMC..-5, TMSH..-5

All inserts have 2 cutting edges, except MiniTM (IC 6.0 mm) which has one edge.
For toolholder information, see page 278.

ACME

Internal

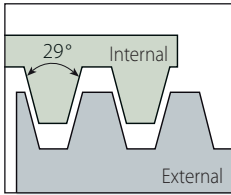

Defined by: ANSI B1/5:1988
Tolerance class: 3G

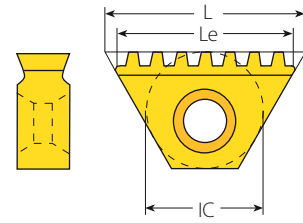
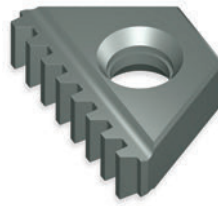

Coarse Pitch TM

Coarse Pitch TM

Thread	Insert Size		Ordering Code	Cutting Edge	Le	Teeth	Bore Dia. Range			
Inch	IC	L Inch	Internal		Inch		Toolholder	Inch		
1/2"-16	6.0mm	.41	6.0116ACMETM028/052...	1	.31	5	TMMC050-6.0	.44		
1/2"-16			6.0116ACMETM028/052...	1	.31	5	TMMC075-6.0	.44		
5/8"-16	1/4"	.43	2116ACMETM028/053...	2	.38	6	TMC050-2	.56		
5/8"-16			2116ACMETM028/053...	2	.38	6	TMC075-2	.56		
5/8"-14			2114ACMETM028/054...	1	.36	5	TMC075-2-124/205	.55		
3/4"-16			2116ACMETM028/055...	2	.38	6	TMC050-2	.69		
3/4"-16			2116ACMETM028/055...	2	.38	6	TMC075-2	.69		
3/4"-14			2114ACMETM028/083...	1	.36	5	TMC075-2-124/206	.68		
3/4"-14			2112ACMETM028/056...	1	.33	4	TMC075-2-124/206	.67		
7/8"-14			3/8"	.63	3114ACMETM028/057...	2	.57	8	TMNC0625-3	.80
7/8"-12			1/4"	.43	2112ACMETM028/058...	1	.33	4	TMC075-2-124/206	.79
1"-14			3/8"	.63	3114ACMETM028/059...	2	.57	8	TMC0625-3	.93
1"-12	3112ACMETM028/060...	2			.58	7	TMNC0625-3	.91		
1"-10	1/2"	.87	4110ACMETM028/061...	1	.70	7	TMC100-4-124/202	.90		
1"-8			418ACMETM028/062...	1	.75	6	TMC100-4-124/202	.87		
1 1/8"-12	3/8"	.63	3112ACMETM028/060...	2	.58	7	TMC0625-3	1.04		
1 1/8"-10	1/2"	.87	4110ACMETM028/084...	1	.70	7	TMC100-4-124/207	1.02		
1 1/8"-8			418ACMETM028/063...	1	.75	6	TMC100-4-124/202	1.00 - 1.12		
1 1/4"-12	3/8"	.63	3112ACMETM028/060...	2	.58	7	TMC075-3	1.17		
1 1/4"-10	5/8"	1.06	5110ACMETM028/064...	2	.90	9	TMC100-5-124/204	1.15		
1 1/4"-8	5/8"	.87	418ACMETM028/063...	1	.75	6	TMC100-4-124/202	1.00 - 1.12		
1 3/8"-10			5110ACMETM028/065...	2	.90	9	TMC100-5-124/204	1.27		
1 3/8"-8			518ACMETM028/066...	2	.88	7	TMC100-5-124/204	1.25		
1 3/8"-6			516ACMETM028/067...	1	.83	5	TMC100-5-124/208	1.20		
1 1/2"-10			5110ACMETM028/068...	2	.90	9	TMC100-5	1.40		
1 1/2"-8			518ACMETM028/069...	2	.88	7	TMC100-5-124/204	1.37		
1 1/2"-6			516ACMETM028/070...	2	.83	5	TMC100-5-124/204	1.33		
1 3/4"-10			5110ACMETM028/064...	2	.90	9	TMC125-5	1.65		
1 3/4"-8			518ACMETM028/069...	2	.88	7	TMC100-5	1.62		
1 3/4"-6			516ACMETM028/070...	2	.83	5	TMC100-5	1.58		
1 3/4"-5	515ACMETM028/071...	2	.80	4	TMC100-5-124/204	1.55				
2"-8	518ACMETM028/069...	2	.88	7	TMC125-5	1.87				
2"-6	516ACMETM028/072...	2	.83	5	TMC100-5	1.83				
2"-5	515ACMETM028/071...	2	.80	4	TMC100-5	1.80				
2 1/4"-6	516ACMETM028/072...	2	.83	5	TMC125-5	2.08				
2 1/4"-5	515ACMETM028/073...	2	.80	4	TMC100-5	2.05				
2 1/2"-5	515ACMETM028/073...	2	.80	4	TMC125-5	2.30				

For toolholder information, see page 282.

Trapez

Internal

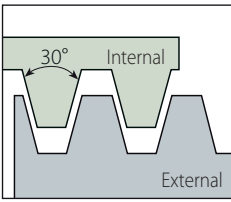
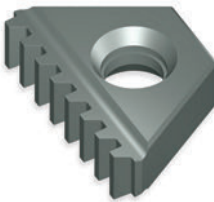
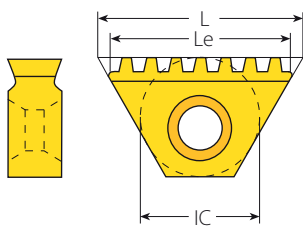
Defined by: Trapez DIN 103
Tolerance class: 7e/7H

Coarse Pitch TM

Coarse Pitch TM

Thread	Insert Size		Ordering Code	Cutting Edge	Le	Teeth	Toolholder	Bore Dia. Range
mm	IC	L Inch	Internal		Inch			Inch
TR 16X2.0	1/4"	.43	212.0TRTM028/028...	1	.39	5	TMC075-2-124/206	.55
TR 18X2.0			212.0TRTM028/029...	1	.39	5	TMC075-2-124/206	.63 - .71
TR 20X2.0			212.0TRTM028/029...	1	.39	5	TMC075-2-124/206	.63 - .71
TR 24X3.0	1/2"	.87	413.0TRTM028/030...	1	.71	6	TMC100-4-124/202	.83
TR 26X3.0			413.0TRTM028/031...	1	.71	6	TMC100-4-124/202	.91 - 1.06
TR 28X3.0			413.0TRTM028/031...	1	.71	6	TMC100-4-124/202	.91 - 1.06
TR 30X3.0			413.0TRTM028/031...	1	.71	6	TMC100-4-124/202	.91 - 1.06
TR 32X3.0			413.0TRTM028/032...	1	.71	6	TMC100-4-124/207	1.14 - 1.30
TR 34X3.0			413.0TRTM028/032...	1	.71	6	TMC100-4-124/207	1.14 - 1.30
TR 36X3.0	5/8"	1.06	413.0TRTM028/032...	1	.71	6	TMC100-4-124/207	1.14 - 1.30
TR 38X3.0			513.0TRTM028/033...	2	.94	8	TMC100-5-124/204	1.38 - 1.54
TR 40X3.0			513.0TRTM028/033...	2	.94	8	TMC100-5-124/204	1.38 - 1.54
TR 42X3.0			513.0TRTM028/033...	2	.94	8	TMC100-5-124/204	1.38 - 1.54
TR 44X3.0			513.0TRTM028/033...	2	.94	8	TMC100-5	1.61 - 1.77
TR 46X3.0			513.0TRTM028/033...	2	.94	8	TMC100-5	1.61 - 1.77
TR 48X3.0			513.0TRTM028/033...	2	.94	8	TMC100-5	1.61 - 1.77
TR 50X3.0			513.0TRTM028/033...	2	.94	8	TMC125-5	1.85 - 2.24
TR 52X3.0			513.0TRTM028/033...	2	.94	8	TMC125-5	1.85 - 2.24
TR 55X3.0			513.0TRTM028/033...	2	.94	8	TMC125-5	1.85 - 2.24
TR 60X3.0			513.0TRTM028/033...	2	.94	8	TMC125-5	1.85 - 2.24
TR 65X4.0			514.0TRTM028/034...	2	.94	6	TMC125-5	2.40 - 4.17
TR 70X4.0			514.0TRTM028/034...	2	.94	6	TMC125-5	2.40 - 4.17
TR 75X4.0			514.0TRTM028/034...	2	.94	6	TMC125-5	2.40 - 4.17
TR 80X4.0			514.0TRTM028/034...	2	.94	6	TMC125-5	2.40 - 4.17
TR 85X4.0			514.0TRTM028/034...	2	.94	6	TMC125-5	2.40 - 4.17
TR 90X4.0			514.0TRTM028/034...	2	.94	6	TMC125-5	2.40 - 4.17
TR 95X4.0			514.0TRTM028/034...	2	.94	6	TMC125-5	2.40 - 4.17
TR 100X4.0	514.0TRTM028/034...	2	.94	6	TMC125-5	2.40 - 4.17		
TR 105X4.0	514.0TRTM028/034...	2	.94	6	TMC125-5	2.40 - 4.17		
TR 110X4.0	514.0TRTM028/034...	2	.94	6	TMC125-5	2.40 - 4.17		

TM Standard

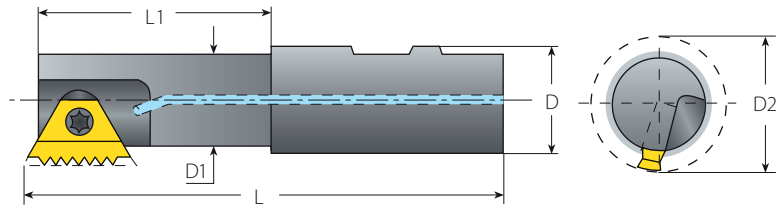
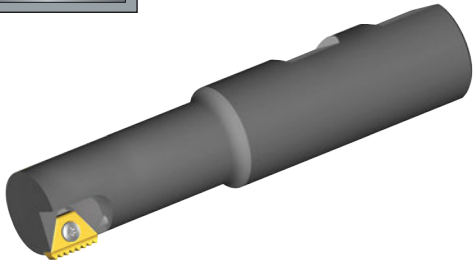
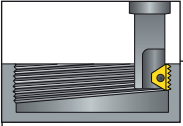

For toolholder information, see page 282.

External and Internal Toolholders



TM Standard

Spare Parts

Insert Size	Ordering Code	EDP No.	Dimensions Inch						
IC			L	L1	D	D1	D2	Insert Screw	Torx Key
6.0mm	TMMC050-6.0	67635	2.72	.57	.50	.27	.35	SN7T	K7T
	TMMC075-6.0	67636	3.50	.67	.75	.27	.35		
1/4"	TMC050-2	67612	2.75	.47	.50	.35	.45	SN2TM	K2T
	TMC075-2	67614	3.50	.79	.75	.35	.45		
	TMC075-2LH	66712	3.50	.79	.75	.35	.45		
3/8"	TMC0625-3	67613	3.56	.87	.625	.54	.67	SN3TM	K3T
	TMC075-3	67615	3.75	1.69	.75	.65	.79		
3/8"B	BTMC0625-3B	67600	3.15	1.14	.625	.53	.67	SN3T	K3T
	BTMC075-3B	67601	3.27	1.14	.75	.61	.75		
	BTMC100-3B	67602	3.68	1.18	1.00	.61	.75		
	BTMWC100-3B	67609	3.62	1.18	1.00	.73	.87		
5/8"	TMC100-5	67616	4.38	2.05	1.00	.94	1.18	SN5TM	K5T
	TMC100-5LH	67617	4.38	2.05	1.00	.94	1.18		
	TMC125-5	67618	4.75	2.28	1.25	1.22	1.46		
3/4"B	TMC125-6B	67619	4.45	2.16	1.25	1.06	1.38	SM7T	K30T
	TMC150-6B	67708	5.25	2.56	1.50	1.50	1.81		

TM Standard

Internal Thread Application for Standard Toolholder

Toolholder		Min. Thread Dia.				
	D2	ISO Coarse	ISO Fine	UNC	UN/UNF/UNEF/UNS	UNJ
TMMC050-6.0 TMMC075-6.0	.35		M10x0.75; M12x1.0; M14x1.25; M14x1.5		7/16-32UN; 7/16-28UNEF; 1/2-24UNS; 7/16-20UNF; 9/16-18UNF; 9/16-16UNF	9/16-24UNJEF; 1/2-20UNJF; 9/16- 18UNJF; 9/16-16UNJF
TMC050-2 TMC075-2 TMC075-2LH	.45		M15x1.0; M16x1.5		9/16-32UN; 9/16-28UN; 9/16-24UNEF; 5/8-20UN; 9/16-18UNF; 9/16-16UNF; 7/8-14UNF	9/16-24UNJEF; 3/4-20UNJEF; 5/8- 18UNJF; 5/8-16UNJF; 7/8-14UNJF
TMC0625-3	.67		M20x1.0; M22x1.5; M24x2.0		3/4-32UN; 13/16-28UN; 7/8-24UNS; 7/8-20UNEF; 7/8-18UNS 7/8-16UNS; 1-14UNS; 1 1/16-12UN	15/8-24UNJ; 7/8-20UNJEF; 1 1/16-18UNJEF; 7/8-16UNJ; 1 5/8-14UNJ; 1 1/16-12UNJ
TMC075-3	.79		M24x1.0; M25x1.5; M27x2.0		7/8-32UN; 15/16-28UN; 1-24UNS; 15/16-20UNEF; 1-18UNS; 1-16 UNS; 1 1/8-14UNS; 1 1/16-12UN	1 5/8-24 UNJ; 15/16-20UNJEF; 1 1/16-18UNJEF; 1-16UNJ; 1 5/8-14UNJ; 1 1/16-12UNJ
BTMC0625-3B	.67		M20x1.0; M22x1.5; M24x2.0		7/8-24UNS; 7/8-20UNEF; 7/8-18UNS; 7/8-16UNS; 1-14UNS; 1 1/16-12UN	
BTMC075-3B BTMC100-3B	.75		M22x1.0; M24x1.5; M25x2.0		7/8-24UNS; 15/16-20UNEF; 1-18UNS; 1-16UNS; 1-14UNS; 1-12UNF	
BTMWC100-3B	.87	M27x1.5	M25x1.0; M30x2		1-24UNS; 1 1/16-20UN; 1 1/16-18UNEF; 1 1/16-16UNEF; 1 1/8-14UNS; 1 1/8-12UNF	
TMC100-5 TMC100-5LH	1.18		M35x1.5; M39x2.0; M36x3.0; M36x4.0; M42x4.5; M48x5.0	1 3/4-5	1 3/8-24UNS; 1 3/8-20UN; 1 7/16-18UNEF; 1 7/16-16UNEF; 1 1/2-14UNS; 1 1/2-12UNF; 1 5/8-10UNS; 1 7/16-8UN; 1 5/8-6UN	1 7/16-16UNJ; 1 1/2-12UNJF
TMC125-5	1.46		M45x1.5; M45x2.0; M50x3.0; M56x4.0		1 5/8-24UNS; 1 11/16-20UN; 1 11/16-18UNEF; 1 11/16-16UNEF; 1 3/4-14UNS; 1 3/4-12 UN; 1 7/8-10UNS; 2-8 UN; 2 1/4-6UN	1 11/16-16UNJ; 1 3/4-12UNJ
TMC125-6B	1.38	M64x6.0	M42x1.5; M42x2.0; M48x3.0; M55x4.0; M48x5.0; M56x5.5	2-4.5; 2 1/2-4	2 1/4-6UN	
TMC150-6B	1.81	M64x6.0	M52x1.5; M55x2.0; M60x3.0; M60x4.0; M60x5.5	2 1/2-4	2 3/8-6UN	

	D2	BSW/BSF	BSP	BSPT	NPT	NPTF	PG	NPS	Trapez	ACME
TMMC050-6.0 TMMC075-6.0	.35	7/16-26BSF; 1/2-20BSW; 7/16-18BSF;	1/4-19				PG7			1/2-16
TMC050-2 TMC075-2 TMC075-2LH	.45	5/8-26BSF; 5/8-20BSW; 9/16-16BSF; 1 1/16-14BSF	3/8-19; 1/2-14	3/8-19			PG9; PG21			5/8-16;
TMC0625-3	.67	13/16-26BSF; 7/8-20BSW; 7/8-16BSW; 13/16-12BSW	5/8-14; 1 1/4-11				PG13.5; PG21	1/2-14; 1-11.5		1-14; 1 1/8-12
TMC075-3	.79	15/16-26BSF; 1-20BSW; 1 11/16-16BSW; 15/16-12BSW;	3/4-14; 1-11				PG16; PG21	3/4-14; 1-11.5		1 1/4-12
BTMC0625-3B	.67	7/8-20BSW; 7/8-16BSW; 13/16-12BSW	5/8-14; 1-11					1-11.5		
BTMC075-3B BTMC100-3B	.75	15/16-20BSW; 1-16BSW; 1 1/16-12BSW	3/4-14; 1-11					1-11.5		
BTMWC100-3B	.87	1 1/16-20BSW; 1 1/8-16BSW	7/8-14; 1-11					1-11.5		
TMC100-5 TMC100-5LH	1.18	1.4-16BSW; 1 3/8-12BSW; 1 7/16-8BSW; 1 3/4-7BSF; 1.6-6BSW	1 1/8-11	1 1/4-11	1 1/4-11.5	1 1/4-11.5	PG29	1 1/4-11.5; 2 1/2-8	TR44-3.0	1 1/2-10; 1 3/4-8; 1 3/4-6; 2-5
TMC125-5	1.46	1 3/4-16BSW; 1 7/8-12BSW; 2.1-8BSW; 1 7/8-6BSW;	1 1/2-11	1 1/2-11	1 1/2-11.5	1 1/2-11.5	PG36	1 1/2-11.5; 2 1/2-8	TR50-3.0; TR65-4.0	1 3/4-10; 2-8; 2 1/4-6; 2 1/2-5
TMC125-6B	1.38	2 1/4-6 BSF; 3-5BSF; 3 1/2-4.5BSF;	1 1/2-11		2 1/2-8	2 1/2-8				
TMC150-6B	1.81	2 5/8-6BSW; 3-5BSF; 3 1/2-4.5BSF	2-11		3-8	3-8				

TM Standard

External and Internal Toolholders

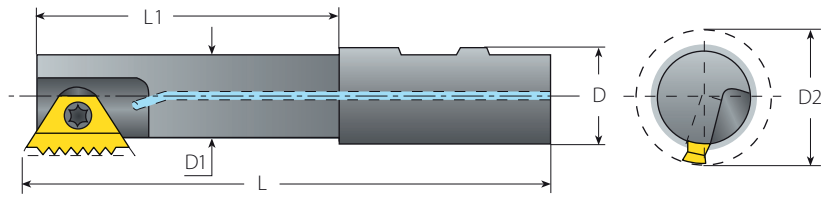
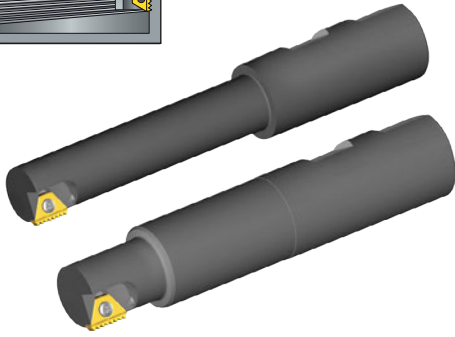
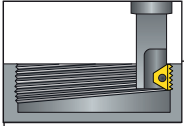

TML Long Tools

Spare Parts

Insert Size	Ordering Code	EDP No.	Dimensions Inch					Spare Parts	
			L	L1	D	D1	D2	Insert Screw	Torx Key
1/4"	TMLC100-2	67719	4.95	.67	1.00	.35	.45	SN2TM	K2T
3/8"	TMLC100-3	67624	5.00	.98	1.00	.73	.87		
3/8"B	BTMLC100-3	67737	4.95	2.50	1.00	.73	.87	SN3T	K3T
	BTMLC075-3B	67603	3.86	1.73	.75	.61	.75		
5/8"	TMLC100-3B	67604	4.95	2.50	1.00	.73	.87	SN3T	K3T
	TMLC100-5	67625	5.88	3.62	1.00	.94	1.18		
3/4"B	TMLC125-5	67628	6.33	3.86	1.25	1.22	1.46	SN5TM	K5T
	TMLC150-6B	67720	6.55	3.74	1.50	1.50	1.81		

Internal Thread Application for TML Toolholder

Toolholder	Min. Thread Dia.					
	D2	ISO Coarse	ISO Fine	UNC	UN/UNF/UNEF/UNS	UNJ
TMLC100-2	.45		M15x1.0; M16x1.5		9/16-32UN; 9/16-28UN; 9/16-24UNEF; 5/8-20UN; 9/16-18UNF; 9/16-16UNF; 7/8-14UNF	9/16-24UNJEF; 3/4-20UNJEF; 5/8-18UNJF; 5/8-16UNJF; 7/8-14UNJF
TMLC100-3 BTMLC100-3	.87	M27x1.5	M25x1.0; M30x2.0		1-32UN; 1-28UN; 1-24UNS; 1 1/16-20UN; 1 1/16-18UNEF; 1 1/16-16UNEF; 1 1/8-14UNS; 1 1/8-12	1 5/8-24 UNJ; 1 1/16-20UNJ; 1 1/16-18UNJEF; 1 1/16-16; 1 1/8-12UNJF
BTMLC075-3B	.75		M22x1.0; M24x1.5; M25x2.0		7/8-24UNS; 15/16-20UNEF; 1-18UNS; 1-16UNS; 1-14UNS; 1-12UNF	
BTMLC100-3B	.87	M27x1.5	M25x1.0; M30x2.0		1-24UNS; 1 1/16-20UN; 1 1/16-18UNEF; 1 1/16-16UNEF; 1 1/8-14UNS; 1 1/8-12UNF	
TMLC100-5	1.18		M35x1.5; M39x2.0; M36x3.0; M36x4.0; M42x4.5; M48x5.0	1 3/4-5	1 3/8-24UNS; 1 3/8-20UN; 1 7/16-18UNEF; 1 7/16-16UNEF; 1 1/2-14UNS; 1 1/2-12UNF; 1 5/8-10UNS; 1 7/16-8UN; 1 5/8-6UN	1 7/16-16UNJ; 1 1/2-12UNJF
TMLC125-5	1.46		M45x1.5; M45x2.0; M50x3.0; M56x4.0		1 5/8-24UNS; 1 11/16-20UN; 1 11/16-18UNEF; 1 11/16-16UNEF; 1 3/4-14UNS; 1 3/4-12UN; 1 7/8-10UNS; 2-8 UN; 2 1/4-6UN	1 11/16-16UNJ; 1 3/4-12UNJ
TMLC150-6B	1.81	M64x6.0	M52x1.5; M55x2.0; M60x3.0; M60x4.0; M60x5.5	2 1/2-4	2 3/8-6UN	

	D2	BSW/BSF	BSP	BSPT	NPT	NPTF	PG	NPS	Trapez	ACME
TMLC100-2	.45	5/8-26BSF; 5/8-20BSW; 1 1/16-14BSF	3/8-19; 1/2-14	3/8-19			PG9; PG21			
TMLC100-3 BTMLC100-3	.87	1 1/16-26BSF; 1 1/16-20BSW; 1 1/8-16BSW	7/8-14; 1-11				PG21	1-11.5		
BTMLC075-3B	.75	15/16-20BSW; 1-16BSW; 1 1/16-12BSW	3/4-14; 1-11					1-11.5		
BTMLC100-3B	.87	1 1/16-20BSW; 1 1/8-16BSW	7/8-14; 1-11				PG21	1-11.5		
TMLC100-5	1.18	1 3/4-7BSF; 1 7/8-6BSW	1 1/4-11	1 1/4-11	1 1/4-11.5	1 1/4-11.5	PG29	1 1/4-11.5; 2 1/2-8	TR44-3.0	1 1/2-10; 1 3/4-8; 1 3/4-6; 2-5
TMLC125-5	1.46	1 7/8-6BSW	1 1/2-11	1 1/2-11	1 1/2-11.5	1 1/2-11.5	PG36	1 1/2-11.5; 2 1/2-8	TR50-3.0; TR65-4.0	1 3/4-10; 2-8; 2 1/4-6; 2 1/2-5
TMLC150-6B	1.81	3-5BSF; 3 1/2-4.5BSF	2-11		2 1/2-8	2 1/2-8				

External and Internal Toolholders

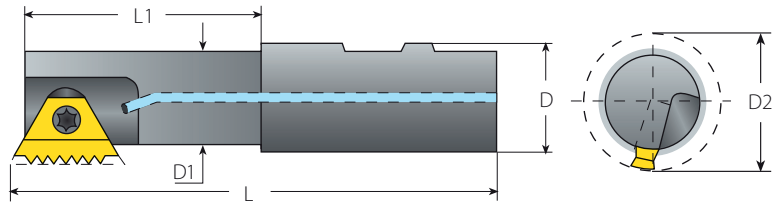
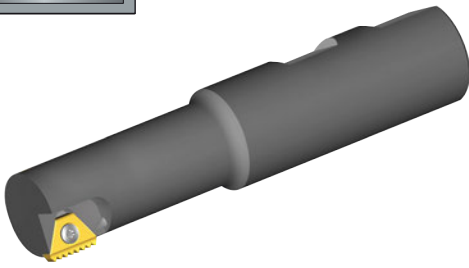
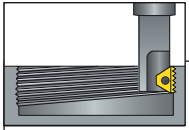

124/... - For Coarse Pitch Threads

Spare Parts

Insert Size	Ordering Code	EDP No.	Dimensions Inch					Spare Parts	
			L	L1	D	D1	D2	Insert Screw	Torx Key
6.0mm	TMMC075-6-124/203	67700	3.50	.59	.75	.26	.35	SN7T	K7T
	TMC075-2-124/205	67702	3.12	.61	.75	.29	.39		
1/4"	TMC075-2-124/206	67703	3.12	.61	.75	.35	.47	SN2TM	K2T
	TMC075-2-124/209	67706	3.12	.61	.75	.29	.39		
3/8"	TMC075-3-124/201	67698	3.75	.81	.75	.48	.61	SN3TM	K3T
1/2"	TMC100-4-124/202	67699	3.58	1.18	1.00	.53	.71	SN4TM	K4T
	TMC100-4-124/207	67704	3.97	1.57	1.00	.63	.79	SA4TM	
5/8"	TMC100-5-124/204	67701	3.98	1.57	1.00	.75	.98	SA5TM	K5T
	TMC100-5-124/208	67705	3.98	1.57	1.00	.65	.87	SN5TM	

Internal Thread Application for 124/... Coarse Pitch Toolholder

Toolholder		Min. Thread Dia.				
	D2	ISO Coarse	ISO Fine	UNC	UN/UNF/UNEF/UNS	UNJ
TMMC075-6 124/203	.35	M12x1.75	M12x1.0; M22x1.5; M12x1.75	7/16-14	1 1/16-32UN; 1/2-24UNS; 9/16-18UNF; 9/16-16UNF	9/16-24UNJEF; 1/2-20UNJF; 9/16-18UNJF; 9/16-16UNJF
TMC075-2 124/205	.39			1/2-13	5/8-12UN	
TMC075-2 124/206	.47			5/8-11		
TMC075-2 124/209	.39					
TMC075-3 124/201	.61	M20x2.5	M20x1.0; M22x1.5; M22x2.0	3/4-10	1 1/16-32UN; 3/4-28UN; 3/4-24UNS; 13/16-20UNEF; 7/8-18UNS; 7/8-16UNS; 7/8-14UNF; 7/8-12UN	15/8-24UNJ; 13/16-20UNJEF; 1 1/16-18UNJEF; 13/16-16UNJ; 7/8-14UNJF; 7/8-12UNJ
TMC100-4 124/202	.71	M22x2.5; M24x3.0		7/8-9; 1 1/8-7		
TMC100-4 124/207	.79			1-8		
TMC100-5 124/204	.98	M30x3.5	M30x1.5; M33x2.0; M39x3.0; M56x4.0	1 3/8-6	1 1/8-24UNS; 1 3/16-20UN; 1 3/16-18UNEF; 1 3/16-16UNEF; 1 1/4-14UNS; 1 1/4-12UNF; 1 1/2-10UNS; 1 1/4-8UN	1 3/16-16UNJ; 1 1/4-12UNJF
TMC100-5 124/208	.87					

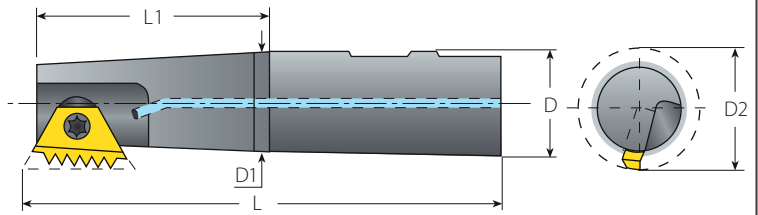
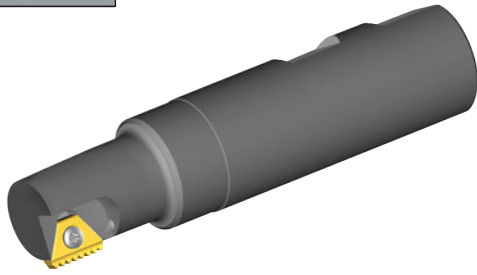

	D2	BSW/BSF	BSP	BSPT	NPT	NPTF	PG	NPS	Trapez	ACME
TMMC075-6 124/203	.35	7/16-26BSF; 7/16-18BSF;	1/4-19				PG7	1/2-14; 1-11.5		
TMC075-2 124/205	.39	1/2-16BSF								5/8-14
TMC075-2 124/206	.47	5/8-14BSF							TR16-2	3/4-14; 3/4-12
TMC075-2 124/209	.39				1/4-18	1/4-18				
TMC075-3 124/201	.61	3/4-12BSF	1/2-14	3/4-14; 1-11	3/4-14; 1-11.5	3/4-14; 1-11.5	PG13.5; PG21	1-11.5		
TMC100-4 124/202	.71	7/8-11BSF; 1-10BSF; 7/8-9BSW; 1-8BSW							TR24-3.0	1-10; 1-8
TMC100-4 124/207	.79								TR32-3.0	1 1/8-10
TMC100-5 124/204	.98	1 3/16-8BSW; 1 1/4-7BSW; 1 3/16-6BSW	1-11	1-11	1 1/4-11.5; 2 1/2-8	1 1/4-11.5; 2 1/2-8	PG21	1 1/4-11.5; 2 1/2-8	TR38-3.0	1 1/4-10; 1 3/8-8; 1 1/2-6; 1 3/4-5
TMC100-5 124/208	.87	1 1/8-7BSW								1 3/8-6

External and Internal Toolholders



TMN - For Conical Threads (NPT, NPTF, BSPT)

Spare Parts

Insert Size	Ordering Code	EDP No.	Ordering Code	EDP No.	Dimensions Inch						
IC	RH		*LH		L	L1	D	D1	D2	Insert Screw	Torx Key
3/8"	TMNC0625-3	67638	TMNC0625-3LH	67639	3.56	.87	.625	.49	.61	SN3TM	K3T
	TMNC075-3	67640	TMNC075-3LH	67641	3.38	.91	.75	.59	.75		
3/8"B	BTMNC0625-3B	67605	BTMNC0625-3BLH	67606	3.15	1.14	.625	.53	.67	SN3TM	K3T
	BTMNC075-3B	67607	BTMNC075-3BLH	67730	3.27	1.14	.75	.61	.75		
5/8"	TMNC125-5	67644	TMNC125-5LH	67645	4.75	2.28	1.25	1.22	1.46	SN5TM	K5T

TM Standard

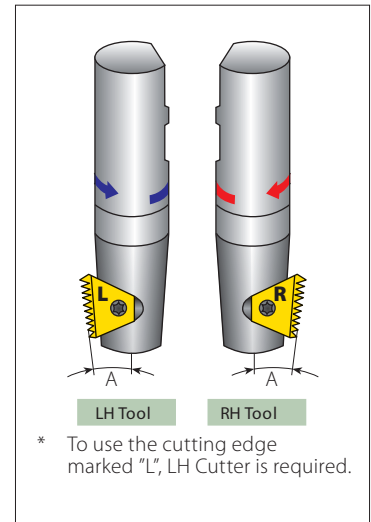

Internal Thread Application for TMN Toolholder

Toolholder		Min. Thread Dia.			
	D2	ISO Fine	UNC	UN/UNF/UNEF/UNS	UNJ
TMNCO625-3 TMNCO625-3LH	.61	M20x1.0; M22x1.5; M22x2.0		1 ¹ / ₁₆ -32UN; 3/4-28UN; 3/4-24UNS; 1 ³ / ₁₆ -20UNEF; 7/8-18UNS; 7/8-16UNS; 7/8-14UNF; 3/4-12UN	1 ⁵ / ₈ -24UNJ; 1 ³ / ₁₆ -20UNJEF; 1 ¹ / ₁₆ -18UNJEF; 1 ³ / ₁₆ -16 UNJ; 7/8-14UNJF; 7/8-12UNJ
TMNCO75-3 TMNCO75-3LH	.75	M22x1.0; M24x1.5; M25x2.0		7/8-32UN; 7/8-28UN; 7/8-24UNS; 1 ⁵ / ₁₆ -20UNEF; 1-18UNS; 1-16UNS; 1-14UNS; 1-12UNF	1 ⁵ / ₈ -24UNJ; 1 ⁵ / ₁₆ -20UNJEF; 1 ¹ / ₁₆ -18UNJEF; 1 ⁵ / ₁₆ -16UNJ; 1 5/8-14UNJ; 1-12UNJF
BTMNC0625-3B BTMNC0625-3BLH	.67	M20x1.0; M22x1.5; M24x2.0		7/8-24UNS; 7/8-20UNEF; 7/8-18UNS; 7/8-16UNS; 1-14UNS; 1 ³ / ₁₆ -12UN	
BTMNC075-3B BTMNC075-3BLH	.75	M22x1.0; M24x1.5; M25x2.0		7/8-24UNS; 1 ⁵ / ₁₆ -20UNEF; 1-18UNS; 1-16UNS; 1-14UNS; 1-12UNF	
TMNCO125-5 TMNCO125-5LH	1.46	M45x1.5; M45x2.0; M50x3.0; M56x4.0		1 ⁵ / ₈ -24UNS; 1 ¹¹ / ₁₆ -20UN; 1 ¹¹ / ₁₆ -18UNEF; 1 ¹¹ / ₁₆ -16UNEF; 1 ³ / ₄ -14UNS; 1 ³ / ₄ -12UN; 1 ⁷ / ₈ -10UNS; 2-8UN; 2 ¹ / ₄ -6UN	

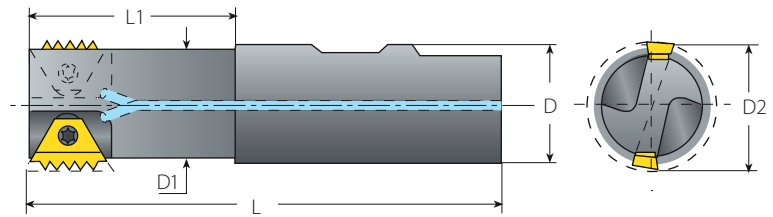
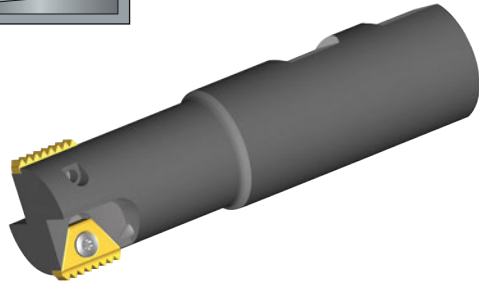
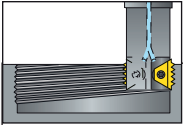

	D2	BSW/BSF	BSP	BSPT	NPT	NPTF	PG	NPS	Trapez	ACME
TMNCO625-3 TMNCO625-3LH	.61	1 ³ / ₁₆ -16BSW	1/2-14	1/2-14; 1-11	1/2-14; 1-11.5	1/2-14; 1-11.5	PG11; PG21	1/2-14; 1-11.5		7/8-14; 1-12
TMNCO75-3 TMNCO75-3LH	.75	1 ⁵ / ₁₆ -26BSW; 1 ⁵ / ₁₆ -20BSW; 1-16BSW; 1 ¹ / ₁₆ -12BSW	3/4-14; 1-11	3/4-14; 1-11	3/4-14; 1-11.5	3/4-14; 1-11.5	PG21	3/4-14; 1-11.5		
BTMNC0625-3B BTMNC0625-3BLH	.67	7/8-20BSW; 7/8-16BSW; 1 ³ / ₁₆ -12BSW	5/8-14; 1-11		3/4-14; 1-11.5	3/4-14; 1-11.5		1-11.5		
BTMNC075-3B BTMNC075-3BLH	.75	1 ⁵ / ₁₆ -20BSW; 1-16BSW; 1 ¹ / ₁₆ -12BSW	3/4-14; 1-11		3/4-14; 1-11.5	3/4-14; 1-11.5		1-11.5		
TMNCO125-5 TMNCO125-5LH	1.46	1 ⁷ / ₈ -6BSW	1 1/2-11	1 1/2-11	1 1/2-11.5; 2 1/2-8	1 1/2-11.5; 2 1/2-8	PG36	1 1/2-11.5; 2 1/2-8		

External and Internal Toolholders



TM2 - Twin Flutes

Spare Parts

Insert Size	Ordering Code	EDP No.	Dimensions Inch						
IC			L	L1	D	D1	D2	Insert Screw	Torx Key
1/4"	TM2C075-2	67685	3.42	.79	.75	.57	.67	SN2TM	K2T
3/8"	TM2C100-3	67686	4.02	1.69	1.00	.89	1.02	SN3T	K3T
3/8"B	BTM2C100-3B	67718	4.13	1.81	1.00	.89	1.02		
5/8"	TM2C125-5	67687	4.65	1.77	1.25	1.42	1.65	SN5TM	K5T
3/4"B	TM2C150-6B	67688	5.33	2.56	1.50	1.73	2.05	SM7T	K30T

Internal Thread Application for TM2 Toolholder

Toolholder	Min. Thread Dia.											
	D2	ISO Fine	UNC	UN/UNF/UNEF/UNS	UNJ	BSW/BSF	BSP	BSPT	NPT	NPTF	PG	NPS
TM2C075-2	.67	M22x1.5		3/4-32UN; 13/16-28UN; 7/8-24UNS; 7/8-20UNEF; 7/8-18UNS; 7/8-16UNS; 1-14UNS	15/8-24UNJ; 7/8-20UNJEF; 11/16-18UNJEF; 7/8-16UNJ; 15/8-14UNJ		5/8-14				PG16; PG21	
TM2C100-3 BTM2C100-3B	1.02	M32x1.5; M33x2.0		11/4-24UNS; 13/16-20UN; 11/4-18UNEF; 11/4-16UNEF; 13/8-14UNS; 15/16-12UN	15/8-24UNJ; 13/16-20UNJ; 11/4-18UNJEF; 11/4-16UNJ; 15/16-12UNJ	13/16-26BSF; 11/4-20BSW; 15/16-16BSW	11/8-11				PG36	11/4-11.5
TM2C125-5	1.65	M48x1.5; M50x2.0; M55x3.0; M64x4.0		17/8-20UN; 2-18UNS; 2-16UNS; 2-14UNS; 2-12UN; 21/4-10UNS; 21/4-8UN; 21/2-6UN	115/16-16UNJ; 2-12UNJ	2-16BSW; 2-12BSW; 21/4-8BSW	2-11	2-11	2-11.5	2-11.5	PG36	2-11.5; 21/2-8
TM2C150-6B	2.05	M58x1.5; M68x4.0; M70x6.0	23/4-4	25/8-6UN		27/8-6BSW; 27/8-5BSW; 33/4-4.5BSF	21/4-11			21/2-8		

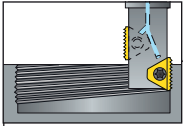

External and Internal Toolholders

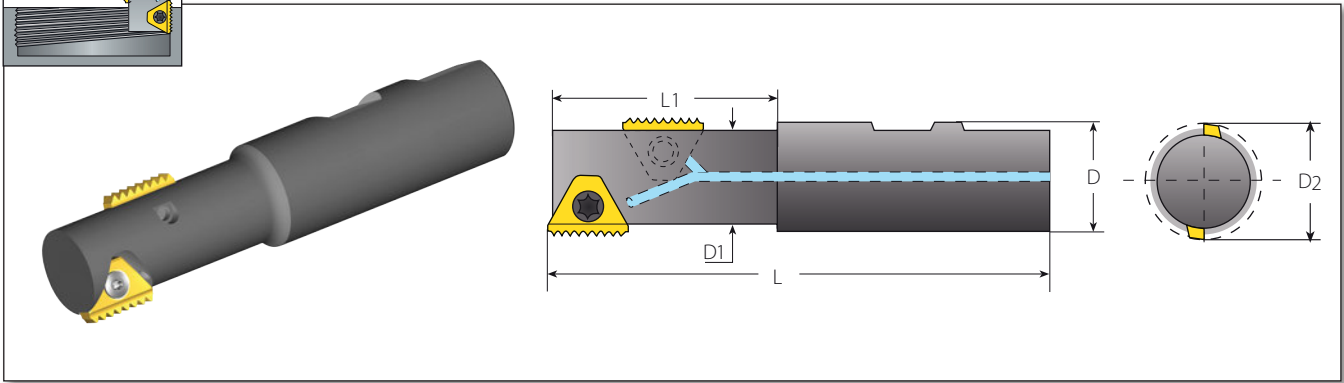

TMO - Twin Flute Offset

Spare Parts

Insert Size	Ordering Code EDP No.		Applicable Threads			Dimensions Inch					Spare Parts	
	IC	External	Internal	External & Internal	L	L1	D	D1	D2	Insert Screw	Torx Key	
1/4"	TMOC075-2-1	67655	16UN	48/32/16UN								
	TMOC075-2-2	67657	24/18UN	48/24/18UN	24W							
	TMOC075-2-3	67658	28/14UN	28/14UN	28/14W							
	TMOC075-2-4	67659	20UN	20UN								
	TMOC075-2-5	67693			26W	3.50	.98	.75	.47	.57	SN2TM	K2T
	TMOC075-2-6	67727			20W							
	TMOC075-2-7	67660			19W							
	TMOC075-2-8	67713	1.0/1.5ISO	0.5/1.0/1.5ISO								
	TMOC075-2-9	67762	0.75ISO	48UN, 0.75ISO								
	TMOC075-2-10	67656	1.25ISO	1.25ISO								
3/8"	TMOC075-3-1	67661	1.5ISO	0.5/1.5ISO								
	TMOC075-3-2	67763	13UN	13UN	26W							
	TMOC075-3-3	67663	28UN	32/28UN								
	TMOC075-3-4	67674	27UN	27UN								
	TMOC075-3-5	67664		11.5UN	11.5NPS							
	TMOC075-3-6	67665	24/20/18/16/14/12UN	24/20/18/16/14/12UN	26/20/18/16/14/12W, 14NPS	3.75	1.69	.75	.65	.79	SN3T	K3T
	TMOC075-3-7	67764	1.25ISO	1.25ISO	24W							
	TMOC075-3-8	67765			19W							
	TMOC075-3-9	67716			11W							
	TMOC075-3-10	67662	1.0/2.0ISO	0.5/1.0/2.0ISO								
	TMOC075-3-11	67766	0.75ISO	32UN, 0.75ISO								
	TMOC075-3-12	67767	1.75ISO	1.75ISO								
5/8"	TMOC100-5-1	67666	24/20/18/14/13/12UN	24/20/18/14/13/11UN	14W							
	TMOC100-5-2	67667	24/18/12UN	24/18/12/6UN	12W							
	TMOC100-5-3	67668	16UN	16UN	16W, 8NPS							
	TMOC100-5-4	67669	14/7UN	14UN	14/7W							
	TMOC100-5-5	67726		11.5UN	11.5NPS							
	TMOC100-5-6	67707	11UN	11UN	11W							
	TMOC100-5-7	67670	10UN	10/5UN	10W							
	TMOC100-5-8	67714	9UN	9UN	9W	4.38	2.05	1.00	.94	1.18	SN5TM	K5T
	TMOC100-5-9	67671	8UN	8UN	8W							
	TMOC100-5-10	67678		7UN								
	TMOC100-5-11	67768	6UN		6W							
	TMOC100-5-12	67712	1.0/2.0/2.5/4.0ISO	1.0/2.0/2.5/4.0/5.0ISO								
	TMOC100-5-13	67769	1.25ISO	1.25ISO								
	TMOC100-5-14	67770	1.5/2.5/4.5ISO	1.5/2.5/4.5/ISO								
	TMOC100-5-15	67771	1.75ISO	1.75ISO								
	TMOC100-5-16	67760	1.0/1.5/3.0/3.5ISO	1.0/1.5/3.0/3.5ISO								

TM Standard

External and Internal Toolholders

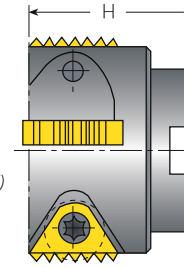
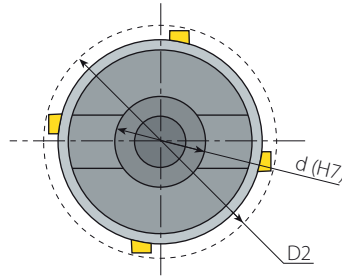
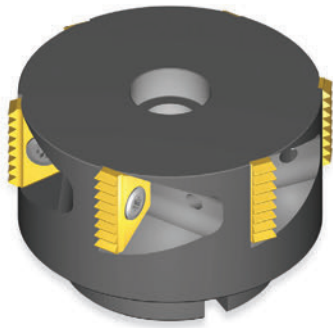
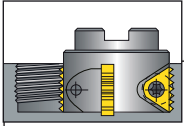

Cutter Drive
ANSI B94.19-1977

TM Shell Mill

Spare Parts

Insert Size	Ordering Code	EDP No.	No. of inserts	Dimensions Inch			Spare Parts		
				D2	d(H7)	H	Insert Screw	Torx Key	Holder Screw
1/4"	TMSH-D150-050-2	67100	6	1.50	1/2	1.58	SN2T	HK2T	1/4 X 28
1/4"	TMSH-D200-075-2	67101	8	1.97	3/4	1.58			3/8 X 24
3/8"	TMSH-D200-075-3	67102	6	1.97	3/4	1.58	SN3TM	HK3T	3/8 X 24
3/8B"	TMSH-D250-075-3B	67103	6	2.48	3/4	1.58			3/8 X 24
5/8"	TMSH-D250-075-5	67104	4	2.48	3/4	1.77	SN5TM	HK5T	3/8 X 24
3/4B"	TMSH-D250-075-6B	67112	4	2.48	3/4	1.97	SM7T	HK7T	3/8 X 24
5/8"	TMSH-D300-100-5	67105	6	3.15	1	2.00	SN5TM	HK5T	1/2 X 20
3/4B"	TMSH-D300-100-6B	67106	5	3.15	1	2.00	SM7T	HK7T	1/2 X 20
5/8"	TMSH-D400-125-5	67107	7	3.94	1 1/4	2.16	SN5TM	HK5T	5/8 X 18
3/4B"	TMSH-D400-125-6B	67772	6	3.94	1 1/4	2.16	SM7T	HK7T	5/8 X 18
5/8"	TMSH-D500-150-5	67109	9	4.92	1 1/2	2.50	SN5TM	HK5T	3/4 X 16
3/4B"	TMSH-D500-150-6B	67110	8	4.92	1 1/2	2.50	SM7T	HK7T	3/4 X 16

Internal Thread Application for Shell Mill Toolholder

Toolholder		Min. Thread Dia.										
	D2	ISO Fine	UNC	UN/UNF/UNEF/UNS	UNJ	BSW/BSF	BSP	BSPT	NPT	NPTF	PG	NPS
TMSH-D150-050-2	1.50	M45x1.5		1 ¹¹ / ₁₆ -20UN; 1 ³ / ₄ -18UNS; 1 ³ / ₄ -16UNS; 1 ⁷ / ₈ -14UNS	1 ⁵ / ₈ -24UNJ; 1 ¹¹ / ₁₆ -20UNJ; 1 ³ / ₄ -16UNJ	1 ³ / ₄ -26BSF; 1 ³ / ₄ -20BSW					PG36	
TMSH-D200-075-2	1.97	M56x1.5		2 ¹ / ₄ -20UN; 2 ¹ / ₄ -18UNS; 2 ¹ / ₄ -16UNS; 2 ¹ / ₄ -14UNS	2 ¹ / ₄ -20UNJ; 2 ¹ / ₄ -16UNJ							
TMSH-D200-075-3	1.97	M56x1.5; M58x2.0		2 ¹ / ₄ -20UN; 3 ¹ / ₄ -18UNS; 3 ¹ / ₄ -16UNS; 3 ¹ / ₄ -14UNS; 2 ³ / ₈ -12UN	2 ¹ / ₄ -20UNJ; 2 ¹ / ₄ -16UNJ; 2 ³ / ₈ -12UNJ	2 ¹ / ₄ -20BSW; 2 ³ / ₈ -16BSW; 2 ³ / ₈ -12BSW	2 ¹ / ₄ -11				PG42	2-11.5
TMSH-D250-075-3B	2.48	M70x1.5; M70x2.0		2 ³ / ₄ -20UN; 2 ³ / ₄ -18UNS; 2 ³ / ₄ -16UNS; 2 ³ / ₄ -14UNS; 2 ⁷ / ₈ -12UN			2 ¹ / ₂ -11					
TMSH-D250-075-5	2.48	M70x1.5; M70x2.0; M75x3.0; M80x4.0		2 ³ / ₄ -20UN; 3 ³ / ₄ -18UNS; 3 ³ / ₄ -16UNS; 3 ³ / ₄ -14UNS; 2 ⁷ / ₈ -12UN; 3-10UNS; 3-8UN	2 ³ / ₄ -16UNJ; 2 ⁷ / ₈ -12UNJ	2 ⁷ / ₈ -16BSW; 2 ⁷ / ₈ -12BSW; 3 ¹ / ₈ -8BSW	2 ¹ / ₂ -11	3-11				3-8
TMSH-D250-075-6B	2.48	M70x2.0; M80x4.0; M85x6.0	3 ¹ / ₄ -4	3 ¹ / ₄ -6UN		3 ³ / ₈ -6BSW; 3 ¹ / ₂ -4.5BSF	2 ¹ / ₂ -11		3-8	3-8		
TMSH-D300-100-5	3.15	M90x2.0; M95x3.0; M95x4.0		3 ¹ / ₂ -18UNS; 3 ¹ / ₂ -16UNS; 3 ¹ / ₂ -14UNS; 3 ¹ / ₂ -12UN; 3 ³ / ₄ -10UNS; 3 ³ / ₄ -8UN	3 ³ / ₈ -16UNJ; 3 ¹ / ₂ -12UNJ	3 ¹ / ₂ -16BSW; 3 ¹ / ₂ -12BSW; 3 ³ / ₄ -8BSW	3 ¹ / ₄ -11	4-11				3 ¹ / ₂ -8
TMSH-D300-100-6B	3.15	M90x2.0; M95x4.0; M105x6.0		3 ⁷ / ₈ -6UN		4-6BSW	3 ¹ / ₄ -11		3 ¹ / ₂ -8	3 ¹ / ₂ -8		
TMSH-D400-125-5	3.94	M110x2.0; M115x3.0; M115x4.0			4 ¹ / ₄ -16UNJ; 4 ³ / ₈ -12UNJ	4 ¹ / ₄ -16BSW; 4 ¹ / ₄ -12BSW; 4 ⁵ / ₈ -8BSW	4-11	4-11				
TMSH-D400-125-6B	3.94	M110x2.0; M115x4.0; M125x6.0				4 ⁷ / ₈ -6BSW	4-11		5-8	5-8		
TMSH-D500-150-5	4.92	M135x2.0; M140x3.0; M140x4.0			5 ¹ / ₄ -16UNJ; 5 ³ / ₈ -12UNJ	5 ¹ / ₄ -16BSW; 5 ¹ / ₄ -12BSW; 5 ⁵ / ₈ -8BSW	5-11	5-11				
TMSH-D500-150-6B	4.92	M135x2.0; M140x4.0; M150x6.0				5 ⁷ / ₈ -6BSW	5-11		5-8	5-8		

External and Internal Toolholders

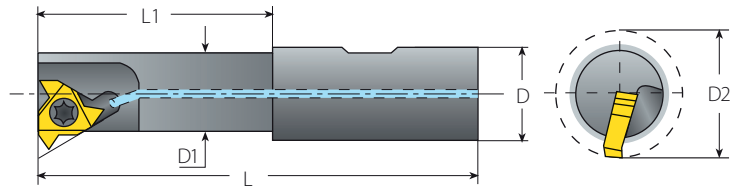
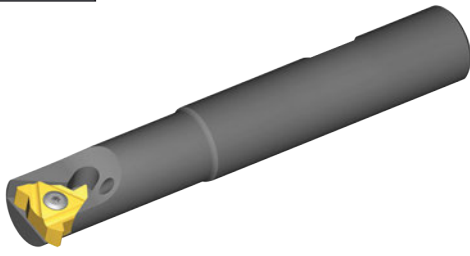
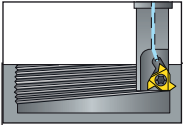

TMS - Single Point (Standard Inserts)

Spare Parts

Insert Size	Ordering Code	EDP No.	Dimensions Inch					Spare Parts	
IC			L	L1	D	D1	D2	Insert Screw	Torx Key
1/4"	TMSC0375-2	67673	2.50	.98	.375	.37	.49	SN2TK	K2T

Use Standard laydown thread turning inserts. See Thread Turning Inserts section - Page 21.
Use external LH inserts for external thread and internal RH inserts for internal thread.

TM Standard

External and Internal Toolholders

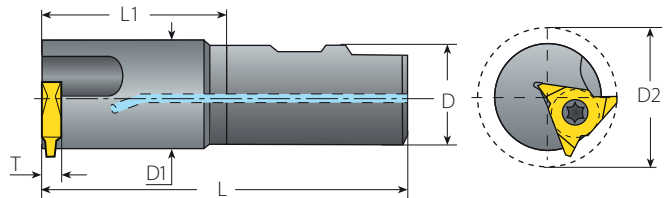
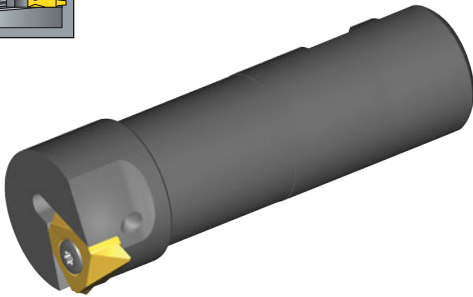
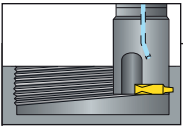

TMV - Single Point (Vertical Insert)

Spare Parts

Insert Size	Ordering Code	EDP No.	Dimensions Inch					Spare Parts	
IC			L	L1	D	D1	D2	Insert Screw	Torx Key
5/8"V	TMVC125-5	67677	4.65	2.36	1.25	1.41	1.81	SN6T	K6T



Requires IC 5/8" Vertical thread turning inserts (width T=6). Use external LH inserts for external threads and internal RH inserts for internal threads.
See Thread Turning Inserts section - Page 21.

Recommended Grades, Cutting Speeds Vc [ft/min] and Feed f [inch/tooth]

Material Group	Vargus No.	Material	Hardness Brinell HB	Vc [ft/min]			Feed f [inch/tooth]	
				Coated		Uncoated		
				VBX	VTX	VK2		
P Steel	1	Unalloyed Steel	Low Carbon (C=0.1-0.25%)	125	328-689	295-591	.002-.0118	
	2		Medium Carbon (C=0.25-0.55%)	150	328-591	295-558	.002-.0098	
	3		High Carbon (C=0.55-0.85%)	170	328-558	295-525	.002-.0079	
	4	Low Alloy Steel (alloying elements ≤5%)	Non Hardened	180	295-525	295-509	.002-.0098	
	5		Hardened	275	262-591	262-525	.002-.0079	
	6		Hardened	350	230-459	230-492	.002-.0059	
	7	High Alloy Steel (alloying elements >5%)	Annealed	200	197-427	230-377	.002-.0079	
	8		Hardened	325	230-361	197-328	.002-.0039	
	9	Cast Steel	Low Alloy (alloying elements <5%)	200	328-558	328-558	328-492	.002-.0059
	10		High Alloy (alloying elements >5%)	225	230-394	230-427	197-427	.002-.0039
M Stainless Steel	11	Stainless Steel Ferritic	Non Hardened	200	328-558	394-591	.002-.0059	
	12		Hardened	330	328-558	394-591	.002-.0039	
	13	Stainless Steel Austenitic	Austenitic	180	230-459	328-459	.002-.0059	
	14		Super Austenitic	200	230-459	328-459	.002-.0039	
	15	Stainless Steel Cast Ferritic	Non Hardened	200	230-459	328-459	.002-.0059	
	16		Hardened	330	230-459	328-459	.002-.0039	
	17	Stainless Steel Cast Austenitic	Austenitic	200	230-394	328-394	.002-.0059	
	18		Hardened	330	230-394	328-394	.002-.0039	
K Cast Iron	28	Malleable Cast Iron	Ferritic (short chips)	130	197-427	328-394	.0008-.0315	
	29		Pearlitic (long chips)	230	197-394	262-328	.0008-.002	
	30	Grey Cast Iron	Low Tensile Strength	180	197-427	262-328	.002-.0059	
	31		High Tensile Strength	260	197-328	262-328	.002-.0039	
	32	Nodular Sg Iron	Ferritic	160	197-410	262-328	.002-.0059	
	33		Pearlitic	260	164-295	197-295	.002-.0039	
N Non-Ferrous Metals	34	Aluminium Alloys Wrought	Non Aging	60	328-820		656-984	.0039-.0157
	35		Aged	100	328-591		197-361	.0039-.0118
	36	Aluminium Alloys	Cast	75	492-1,312		197-394	.0039-.0118
	37		Cast & Aged	90	492-919		197-328	.002-.0098
	38	Aluminium Alloys	Cast Si 13-22%	130	262-492		66-164	.0039-.0118
	39	Copper and Copper Alloys	Brass	90	394-689	328-656	164-230	.0039-.0118
	40		Bronze And Non Leded Copper	100	394-689	328-656	164-230	.002-.0098
S Heat Resistant Material	19	High Temperature Alloys	Annealed (iron based)	200	66-148	66-131	66-98	.002-.0039
	20		Aged (iron based)	280	66-98	66-98	49-82	.0008-.002
	21		Annealed (nickel or cobalt based)	250	66-164	49-66	49-66	.0008-.002
	22		Aged (nickel or cobalt based)	350	33-49	33-49	33-49	.0008-.002
	23	Titanium Alloys	Pure 99.5 Ti	400Rm	230-459	230-394	131-197	.0008-.002
	24		α+β Alloys	1050Rm	66-164	66-164	66-131	.0008-.002
H Hardened Material	25	Extra Hard Steel	Hardened & Tempered	45-50HRc	66-148	66-148		.0004-.0012
	26			51-55HRc	66-148	66-148		.0004-.0008

TM Standard

Grades

Grade	Application	Sample
VBX	First choice for steel and cast iron A tough sub-micron substrate with TiCN coating	
VTX	First choice for stainless steel A tough sub-micron substrate with TiAlN coating	
VK2	Uncoated grade for machining cast iron & nonferrous metals	



TMSD







Thread Milling for Deep Holes

Inserts | Toolholders

Vardex Ordering Code System

TMSD Inserts

2	U	I	DB	60	TM	VBX
1	2	3	4	5	6	7

1 - Insert Size	2 - Insert Style	3 - Type of Insert	4 - Pitch					5 - Standard
5 - IC5.0 mm 2 - IC1/4" 3 - IC3/8" 4 - IC1/2" 5 - IC5/8" 7 - IC6.8 mm 9 - IC8.5 mm 11 - IC10.7 mm 	 U -  A -  L -  V - Vertical Style 7, 9, 11  V - V Style 5/8"	I - Internal EI - External + Internal	Full Profile - Pitch Range		5 - Standard			
			mm		TPI		60 - Partial Profile 60°	
1.0-8.0		18-2.5		55 - Partial Profile 55°				
Partial Profile - U, A, L Styles		Partial Profile - Vertical Style			ISO - ISO Metric			
mm		TPI		UN - American UN				
DA	0.5-1.5	48-16	VA	0.5-1.0	28-27			
DB	1.5-2.0	16-12	VB	-	11-9			
DC	2.5-4.0	10-6	VC	-	16-10			
DD	2.0-2.5	9-12	VD	1.0-2.0	24-12			
DE	2.5-3.5	10-7	VE	2.0-3.0	12-8			
DH	4.0-6.0	6-4	VF	1.0-1.5	24-16			
DK	6.0-8.0	4-3	VG	1.5-2.0	16-12			
DL	-	11-7	VH	-	16-14			
DM	2.5	10	VK	2.0-2.5	12-10			
DN	1.0-2.0	24-11	VJ	-	26-19			
DP	1.5-3.0	16-8	VM	-	8-7			
DR	-	26-14	VN	1.5-2.5	16-11			
DT	2.0-4.0	12-6						

TMSD Toolholders (U, A, L Styles)

C	TM	2	S	C	056	C	068	-	235	-	2	U
1	2	3	4	5	6	7	8		9		10	11

1 - Shank Style	2 - System	3 - No. of Flutes	4 - Insert Type	5 - Cooling	6 - Shank Dia.	7 - Shank Type	8 - Cutting Dia.
None - Steel C - Carbide Shank	TM	1-4	S - Single Point	C - Coolant	.3125 - 1.50	W - Weldon C - Cylindrical	.51 - 1.65

9 - Max. Tool Overhang	10 - Insert Size	11 - Insert Style	12 - Tool Application
5.67	5 - IC5.0 mm 2 - IC1/4" 3 - IC3/8" 4 - IC1/2"	U A L	ABUT - For American Buttress

TMSD Toolholders (Vertical Style)

C	GM	C	9	C	13	-	45	-	7	-	3
1	2	3	4	5	6		7		8		9

1 - Holder Type	2 - System	3 - Cooling	4 - Shank Dia.	5 - Shank Style	6 - Cutting Dia.	7 - Tool Overhang	8 - Insert Size
None - Steel Shank C - Carbide Shank	GM - Groove Milling and Thread Milling	C - Coolant	.75 - 2.56	C - Cylindrical W - Weldon	.41-.87	.98-2.56	7 - IC6.8 mm 9 - IC8.5 mm 11 - IC10.7 mm

9 - Number of Flutes
3

TMSD Shell Mill (U, L, V Styles)

TM	4	S	C		D169	-	050	-	3	U	
1	2	3	4		5		6		7	8	9

1 - System	2 - No. of Flutes	3 - Insert Type	4 - Cooling	5 - Cutting Dia.	6 - Drive Hole Dia.	7 - Insert Size	8 - Insert Style
TM	4-7	S - Single Point	C - Coolant	1.69-4.35	.50, .75, 1.00, 1.50	3 - IC3/8" 4 - IC1/2" 5 - IC5/8"	U, L, V

9 - Tool Application
ABUT - American Buttress

TMSD

Thread Milling for Deep Holes

A multi-flute, highly productive and economical solution for milling threads in deep holes



Full Profile Inserts

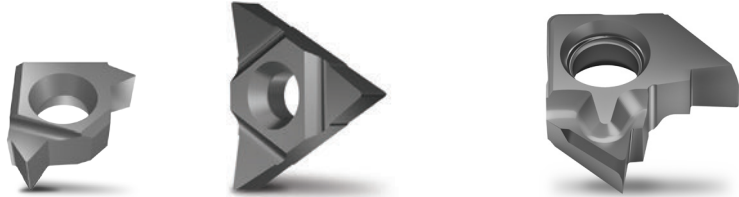

ISO, American UN, NPT, API RD

American Buttress

U Style For Large Pitches

Weldon Shank



Tool Overhang (L1) 1.57-4.72
Cutting Dia. (D2) .58-1.66
No. of Flutes (Z) 1-4

Carbide Cylindrical Shank

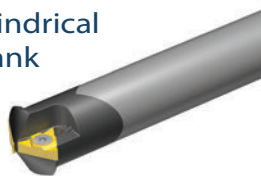

Tool Overhang (L1) max 5.3
Cutting Dia. (D2) .58-1.24
No. of Flutes (Z) 1-4

Steel Cylindrical Shank



Tool Overhang (L1) max 5.65
Cutting Dia. (D2) .91-1.46
No. of Flutes (Z) 2-4

Shell Mill



Tool Overhang (L1) max 7.87
Cutting Dia. (D2) 1.69-4.35
No. of Flutes (Z) 4-8

L Style (Mini L) For Small Bores

Weldon Shank



Tool Overhang (L1) 1.14-1.80
Cutting Dia. (D2) .51-.72
No. of Flutes (Z) 1-3

Carbide Cylindrical Shank



Tool Overhang (L1) max 2.56
Cutting Dia. (D2) .51-.72
No. of Flutes (Z) 1-3

Vertical Style (7V, 9V, 11V)

Weldon Shank



Tool Overhang (L1) .98-1.77
Cutting Dia. (D2) .41-.82
No. of Flutes (Z) 3

Carbide Cylindrical Shank



Tool Overhang (L1) max 2.56
Cutting Dia. (D2) .41-.82
No. of Flutes (Z) 3

L Style (3/8" L) For Large Trapezoid Profiles and ABUT

Weldon Shank



Tool Overhang (L1) 2.0-4.13
Cutting Dia. (D2) .85-1.4
No. of Flutes (Z) 1-3

Carbide Cylindrical Shank



Tool Overhang (L1) max 4.43
Cutting Dia. (D2) .85-1.32
No. of Flutes (Z) 1-3

Shell Mill

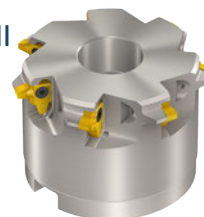

Tool Overhang (L1) max 7.87
Cutting Dia. (D2) 2.28-3.15
No. of Flutes (Z) 5-7

A Style For Shorter L2

Steel Cylindrical Shank



Tool Overhang (L1) max 5.12
Cutting Dia. (D2) 1.02-1.39
No. of Flutes (Z) 3

TMSD

Partial Profile 60°

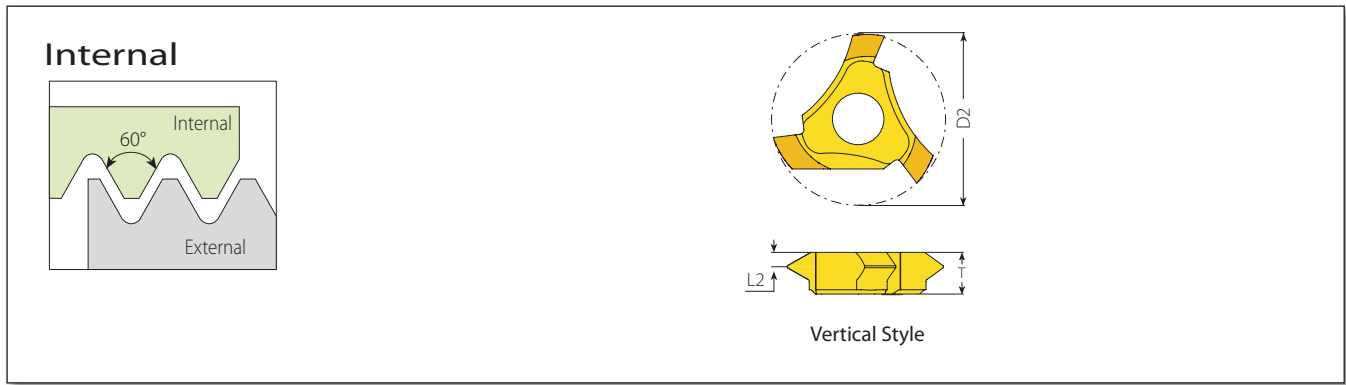

Vertical Style

Insert Style	Pitch		Ordering Code	EDP No.		Dimensions Inch			Application (Min. Thread Size)				Toolholder
	mm	TPI		Internal	VTX	VBX	D2	T	L2	ISO Coarse	ISO Fine	UNC	
7V	0.5-1.0	28-27	7VIVA60TM3...	59605	59606	.413	.11	.024	-	M11.5x0.5; M11.5x0.75; M12x1.0	-	1/2-28UNEF; 1/2-27UNS	CGMC5/16C13-40-7-3 GMC075W050-100-7-3 CGMC9C13-45-7-3
	1.0-1.5	24-16	7VIVF60TM3...	59607	59608	.437	.11	.031	-	M12.5x1; M13x1.5	-	1/2-24UNS; 1/2-20UNF; 5/16-18UNF; 5/16-16UN	
	1.5-2.0	16-12	7VIVG60TM3...	59611	59612	.465	.11	.039	M14x2.0	M14x1.5	-	5/16-16UN; 5/16-14UNS; 5/16-12UN	
	1.5-2.5	16-11	7VIVN60TM3...	30156	30157	.488	.11	.043	-	M15x1.5 M16x2 M18x2.5	5/8-11; 5/8-12	5/8-14UNS; 5/8-16UN	
9V	0.5-1.0	28-27	9VIVA60TM3...	59613	59614	.516	.17	.024	-	M14x0.5; M14x0.75; M15x1	-	5/16-28UN; 5/16-27UNS	CGMC7/16C17-45-9-3 GMC075W066-118-9-3 CGMC11.5C17-50-9-3
	1.0-1.5	24-16	9VIVF60TM3...	59615	59616	.539	.17	.031	-	M15x1; M15.5x1.5	-	5/8-24UNEF; 5/8-20UN; 5/8-18UNF; 5/8-16UN	
	1.5-2.0	16-12	9VIVG60TM3...	59617	59618	.567	.17	.039	-	M16.5x1.5; M17x2	-	11/16-16UN; 3/4-14UNS; 11/16-12UN	
	2.0-2.5	12-10	9VIVK60TM3...	59619	59620	.594	.17	.055	-	M17.5x2; M18x2.5	3/4-10	11/16-12UN;	
11V	1.0-2.0	24-12	11VVD60TM3...	59621	59622	.705	.22	.039	-	M19x1, M19.5x1.25; M19.5x1.5; M20x1.75; M20x2	-	3/4-24UNS; 13/16-20UNEF; 7/8-18UNS; 13/16-16UN; 7/8-14UNF; 13/16-12UN	CGMC5/8C22-65-11-3 GMC100W085-175-11-3 CGMC15C22-65-11-3
	2.0-3.0	12-8	11VIVE60TM3...	59623	59624	.768	.22	.059	M22x2.5 M24x3	M23x2	1-8	7/8-10UNS; 7/8-12UN	

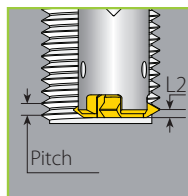

Vertical Style

Partial Profile 55°

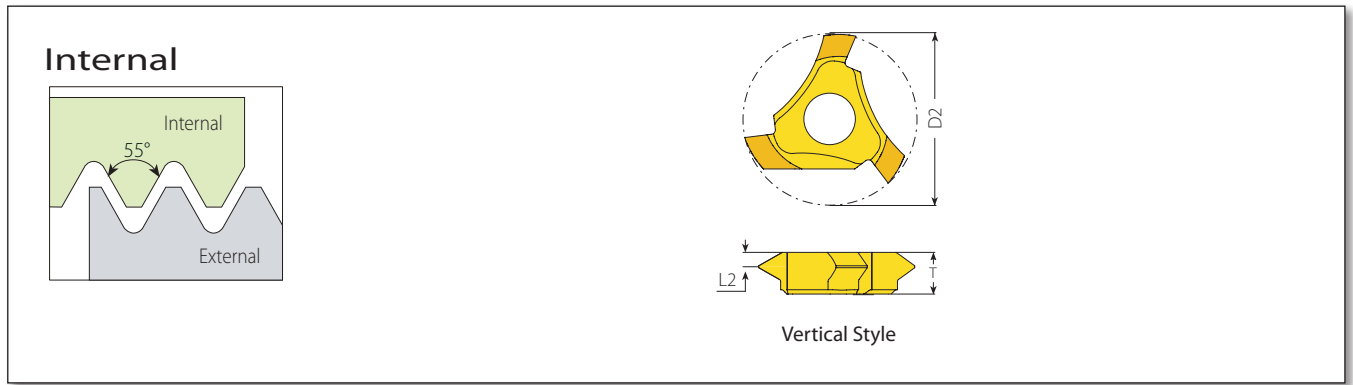

Vertical Style



Insert Style	Pitch	Ordering Code	EDP No.		Dimensions Inch				Application (Min. Thread Size)		
			VTX	VBX	D2	T	L2	r	BSP (G)	Partial 55°	Toolholder
7V	26-19	7VIVJ55TM3...	59625	59626	.447	.11	.031	.003	¼-19; ⅜-19	-	CGMC5/16C13-40-7-3 GMC075W050-100-7-3 CGMC9C13-45-7-3
	16-14	7VIVH55TM3...	59627	59628	.472		.039	.005	½-14; ⅝-14; ¾-14; 7/8-14;	9/16-16; ⅝-14	
9V	26-19	9VIVJ55TM3...	59629	59630	.526	.17	.031	.004	⅜-19	⅝-26; ⅜-16	CGMC7/16C17-45-9-3 GMC075W066-118-9-3 CGMC11.5C17-50-9-3
	16-10	9VIVC55TM3...	59631	59632	.606		.047	.006	½-14	¾-16; 1½-14; ¾-12; ⅞-11; ¾-10	
11V	16-12	11VIVG55TM3...	59633	59634	.701	.22	.035	.006	½-14	1⅜-16; 1⅝-12	CGMC5/8C22-65-11-3 GMC100W085-175-11-3 CGMC15C22-65-11-3
	11-9	11VIVB55TM3...	59635	59636	.752		.051	.008	1-11	⅞-11; 1-10; 1⅝-9	
	8-7	11VIVM55TM3...	59637	59638	.772		.059	.014	-	1-8; 1⅝-7;	

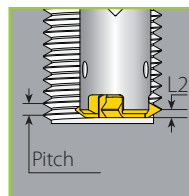

Vertical Style

TMSD

Trapez

Internal

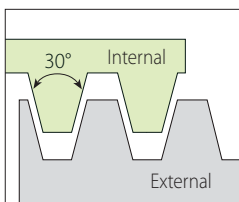

Defined by: DIN 103
Tolerance class: 7e/7H

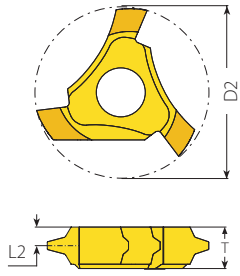

Vertical Style

Vertical Style

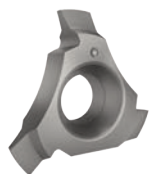

Insert Style	Pitch mm	Ordering Code Internal	EDP No.		Dimensions Inch			Application	
			VTX	VBX	D2	T	L2	Trapez	Toolholder
7V	2.0	7VI2.0TR-1TM3...	59639	59640	.484	.11	.051	TR16x2	CGMC5/16C13-40-7-3 GMC075W050-100-7-3 CGMC9C13-45-7-3
		7VI2.0TR-2TM3...	59641	59642				TR18x2	
		7VI2.0TR-3TM3...	59643	59644				TR20x2	
9V	3.0	9VI3.0TR-1TM3...	59645	59646	.606	.17	.077	TR22x3	CGMC7/16C17-45-9-3 GMC075W066-118-9-3 CGMC11.5C17-50-9-3
		9VI3.0TR-2TM3...	59647	59648				TR24x3	

TMSD

Stub ACME

Internal

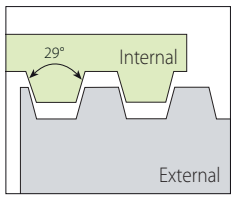

Defined by: ANSI B1.8: 1988
Tolerance class: 2G

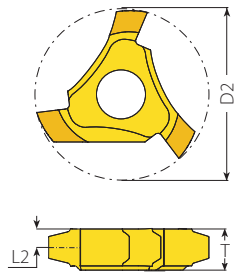

Vertical Style

Vertical Style



Insert Style	Pitch TPI	Ordering Code Internal	EDP No.		Dimensions Inch			Application	
			VTX	VBX	D2	T	L2	Stub ACME	Toolholder
7V	8	7VI8STACMETM3...	59649	59650	.484	.11	.051	5/8-8	CGMC5/16C13-40-7-3 GMC075W050-100-7-3 CGMC9C13-45-7-3
		7VI6STACME-1TM3...	59651	59652				3/4-6	
		7VI6STACME-2TM3...	59653	59654				7/8-6	
9V	5	9VI5STACME-1TM3...	59655	59656	.657	.17	.077	1-5	CGMC7/16C17-45-9-3 GMC075W066-118-9-3 CGMC11.5C17-50-9-3
		9VI5STACME-2TM3...	59657	59658				1 1/8-5	
		9VI5STACME-3TM3...	59659	59660				1 1/4-5	
11V	4	11VI4STACME-1TM3...	59661	59662	.819	.22	.102	1 3/8-4	CGMC5/8C22-65-11-3 GMC100W085-175-11-3 CGMC15C22-65-11-3
		11VI4STACME-2TM3...	59663	59664				1 1/2-4	
		11VI4STACME-3TM3...	59665	59666				1 3/4-4	
		11VI4STACME-4TM3...	59667	59668				2-4	

Vertical Toolholders - Weldon Shank

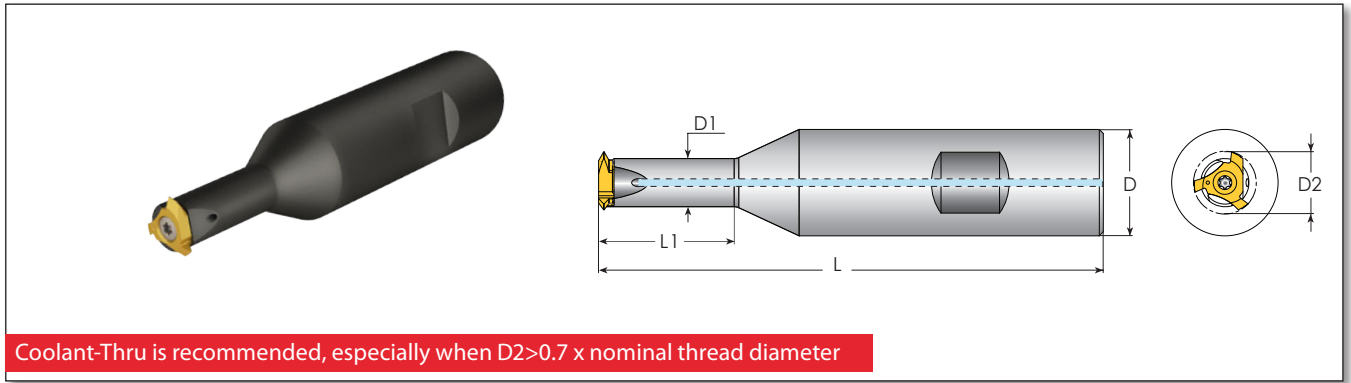

Insert Style	Ordering Code	EDP No.	Dimensions Inch					Spare Parts			
			L	L1	D	D1	D2*	Insert Screw	Torx Key	Blade	Handle
7V	GMC075W050-100-7-3	67146	3.78	.98	.75	.35	.41-.50	SN2T8-M1 (M3.0x0.5x9) (70266)	K2T (70020)	-	-
9V	GMC075W066-118-9-3	67147	4.13	1.18	.75	.45	.51-.65	SN3T15-M2 (M4x0.7x13.5) (70267)	-	Blade T15-1/4 (72009)	Smart Handle 1/4x2 (72010)
11V	GMC100W085-175-11-3	67148	4.53	1.77	1.0	.63	.70-.82	SN4T20-M3 (M5x0.8x15.5) (70268)	-	Blade T20-1/4 (72008)	Smart Handle 1/4x2 (72010)

* The tool cutting diameter (D2) is defined by the insert (See pages 298-300).

For Correct Clamping:

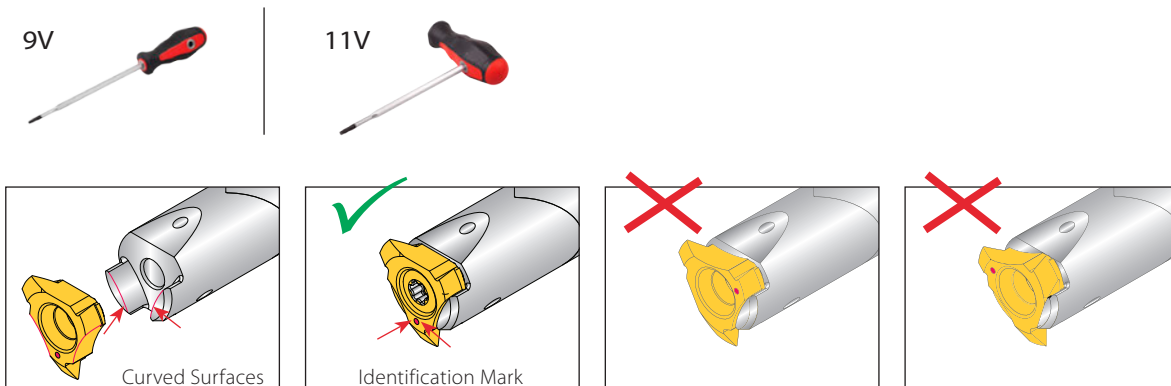

Always mount insert with the identification mark between the two curved surfaces on the toolholder.

TMSD

Vertical Toolholders - Carbide Cylindrical Shank

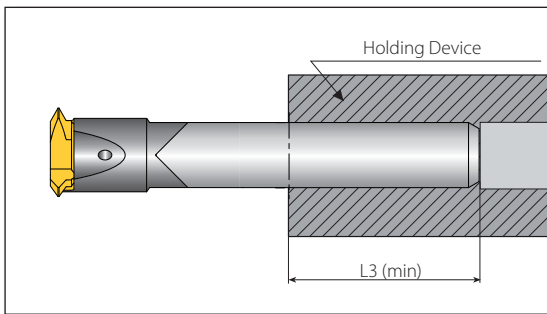
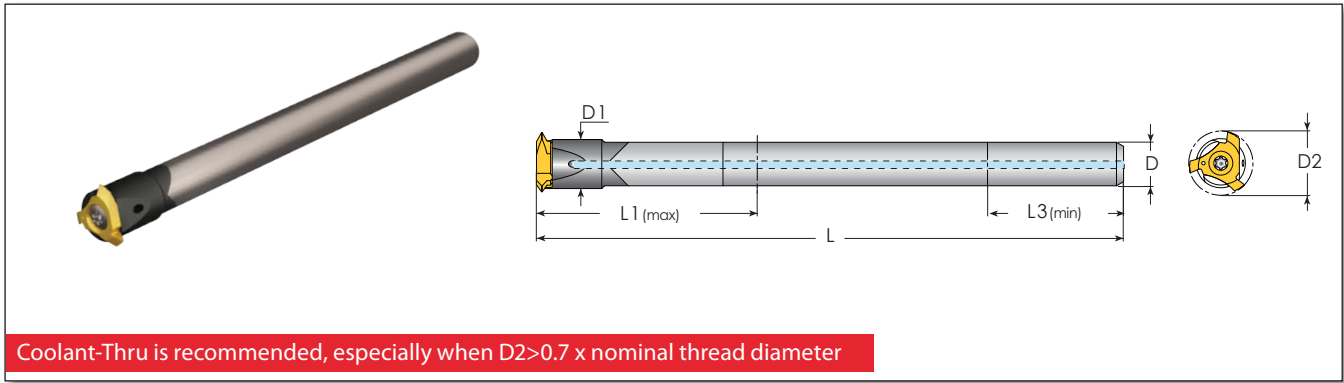

Spare Parts

Insert Style	Ordering Code	EDP No.	Dimensions Inch						Spare Parts			
			L	L1	L3 (min)	D	D1	D2*	Insert Screw	Torx Key	Blade	Handle
7V	CGMC9C13-45-7-3	67140	4.53	1.77	.79	.354	.35	.41-.50	SN2T8-M1 (M3.0x0.5x9) (70266)	K2T (70020)	-	-
	CGMC5/16C13-40-7-3	67141		1.57	.71	5/16						
9V	CGMC11.5C17-50-9-3	67142	4.92	1.97	.98	.453	.45	.51-.65	SN3T15-M2 (M4x0.7x13.5) (70267)	-	Blade T15-1/4 (72009)	Smart Handle 1/4x2 (72010)
	CGMC7/16C17-45-9-3	67143		1.77	.98	7/16						
11V	CGMC15C22-65-11-3	67144	5.31	2.56	1.26	.591	.59	.70-.82	SN4T20-M3 (M5x0.8x15.5) (70268)	-	Blade T20-1/4 (72008)	Smart Handle 1/4x2 (72010)
	CGMC5/8C22-65-11-3	67145		2.56	1.34	5/8						

* The tool cutting diameter (D2) is defined by the insert (See pages 298-300).

For Correct Clamping:

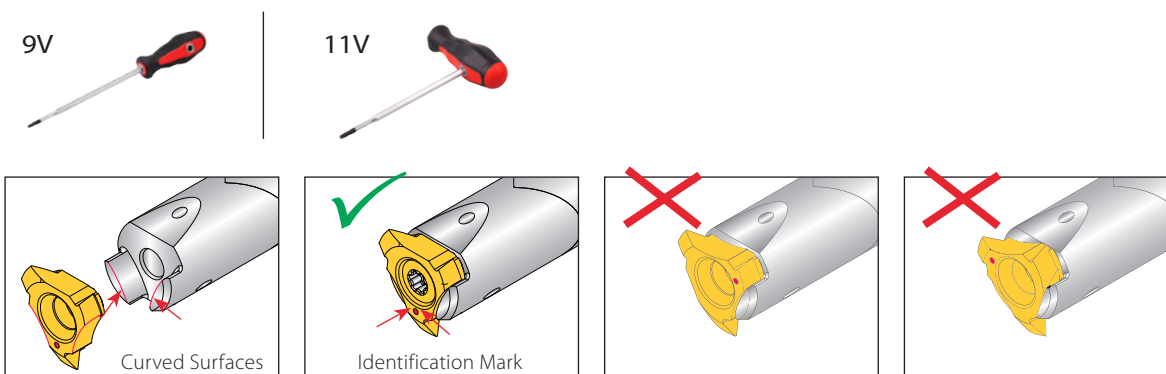

Always mount insert with the identification mark between the two curved surfaces on the toolholder.

Partial Profile 60°

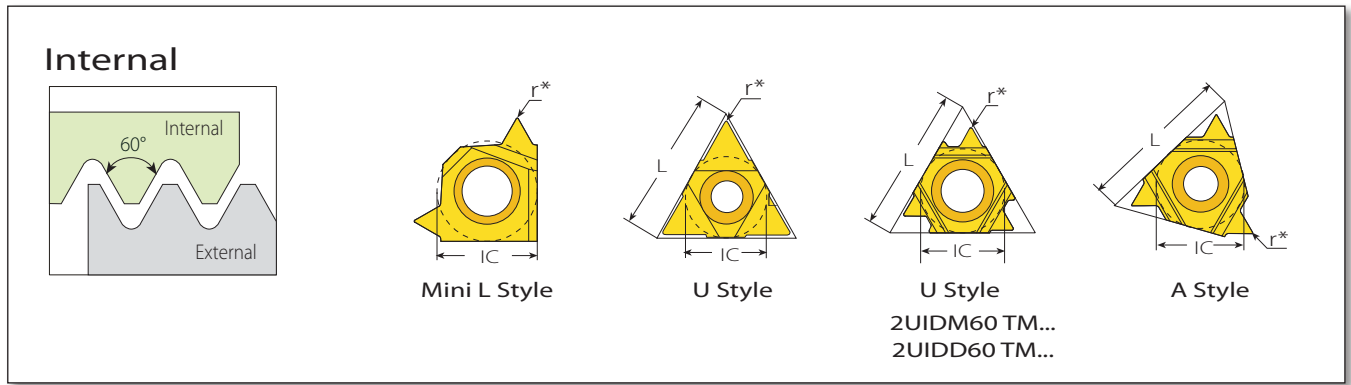

L Style



Insert Size		Pitch		Ordering Code	EDP No.		Dimensions Inch		Toolholder
IC	L	mm	TPI	Internal	VTX	VBX	r*		
5.0L (Mini L)	-	0.5-1.5	48-16	5LIDA60TM...	50264	50263	.002	TM.SC...5L	
		1.0-2.0	24-11	5LIDN60TM...	50267	50266	.002	CTM. SC...5L	

U Style



2UIDM60 TM...
2UIDD60 TM...



Insert Size		Pitch		Ordering Code	EDP No.		Dimensions Inch		Toolholder
IC	L	mm	TPI	Internal	VTX	VBX	r*		
1/4"U	.43	0.5-1.5	48-16	2UIDA60TM...	50305	50299	.002	TM.SC...2U CTM. SC...2U	
		1.5-2.0	16-12	2UIDB60TM...	50018	50008	.002		
		2.0-2.5	9-12	2UIDD60TM...	50355	50352	.004	CTM2SC 056C068-235-2U	
		2.5	10	2UIDM60TM...	50296	50291	.004		
3/8"U	.63	1.5-2.0	16-12	3UIDB60TM...	50040	50034	.002	TM.SC...2U CTM. SC...2U	
		2.5-3.5	10-7	3UIDE60TM...	50044	50041	.006	TM.SC...3U	
		4.0-6.0	6-4	3UIDH60TM...	50048	50045	.001		
1/2"U	.87	6.0-8.0	4-3	4UIDK60TM...	50052	50049	.012	TM.SC D...4U	

A Style



Insert Size		Pitch		Ordering Code	EDP No.		Dimensions Inch		Toolholder
IC	L	mm	TPI	Internal	VTX	VBX	r*		
1/4"A	.43	1.5-3.0	16-8	2AIDP60TM...	50219	50200	.002	TM.SC...2A	
3/8"A	.63	2.0-4.0	12-6	3AIDT60TM...	50227	50226	.003	TM.SC...3A	

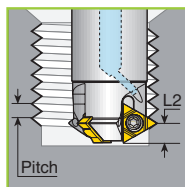

U Style
For Large Pitches

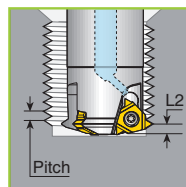

A Style
For Shorter L2

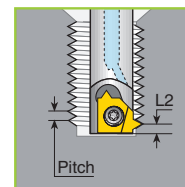

Mini-L Style
For Small Bores and Short L2

* The indicated radius (r) refers to the insert nose radius only.

Partial Profile 55°

Internal

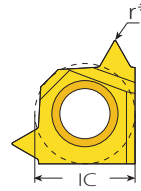
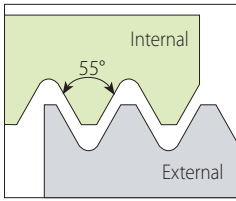

Mini L Style

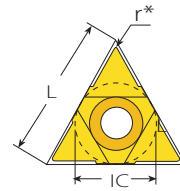

U Style

L Style



Insert Size	Pitch	Ordering Code	EDP No.		Dimensions Inch	
			VTX	VBX	*r	Toolholder
IC	TPI	Internal				
5.0L (Mini L)	26-14	5LIDR55TM...	50269	50269	.004	TM.SC...5L CTM. SC...5L

U Style



Insert Size		Pitch	Ordering Code	EDP No.		Dimensions Inch	
IC	L mm			VTX	VBX	*r	Toolholder
1/4"U	.43	48-16	2UIDA55TM...	50317	50309	.004	TM.SC...2U CTM. SC...2U
		16-12	2UIDB55TM...	50055	50053	.003	
		11-7	2UIDL55TM...	50061	50056	.010	
3/8"U	.63	16-12	3UIDB55TM...	50067	50062	.003	TM.SC...3U
		11-7	3UIDL55TM...	50091	50068	.009	
		6-4	3UIDH55TM...	50148	50233	.011	
1/2"U	.87	4-3	4UIDK55TM...	50190	50189	.020	TM.SC D...4U

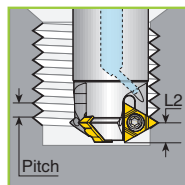

U Style
For Large Pitches

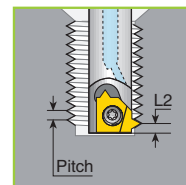

Mini-L Style
For Small Bores and Short L2

* The indicated radius (r) refers to the insert nose radius only.

ISO Metric

Internal

Defined by: R262 (DIN 13)
Tolerance class: 6g/6H

Mini L Style
5LI2.0ISOTM...

Mini L Style

U Style

L Style

Insert Size IC	Pitch mm	Ordering Code Internal	EDP No.		Toolholder	Toolholder Cutting Diameter D2 (Inch)
			VTX	VBX		Adjusted D2
5.0L (Mini L)	1.0	5LI1.0ISOTM...	59726	59725	TM.SC...5L CTM.SC...5L	-
	1.5	5LI1.5ISOTM...	59780	59779		-
	2.0	5LI2.0ISOTM...	59782	59781		-

U Style

Insert Size IC	L mm	Pitch mm	Ordering Code Internal	EDP No.		Toolholder	Toolholder Cutting Diameter D2 (Inch)
				VTX	VBX		* Adjusted D2
1/4"U	0.43	1.5	2UI1.5ISOTM...	50419	50418	TM2SC 100W090-275-2U; TM3SC 100W102-315-2U; TM4SC 125W122-374-2U; TM2SC 062C090-300-2U; TM3SC 075C102-415-2U; TM4SC 100C122-452-2U;	For 1.5ISO change D2 to D2-.039
		2.0	2UI2.0ISOTM...	50435	50427	CTM3SC 075C102-433-2U; CTM4SC 100C124-530-2U	For 2.0ISO change D2 to D2-.045

* Correct the toolholder cutting diameter D2 according to adjustment, as indicated in the above table.

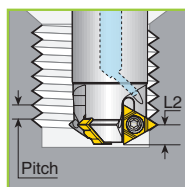

U Style
For Large Pitches

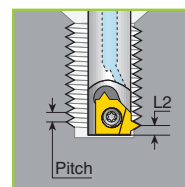

Mini-L Style
For Small Bores and Short L2

American UN - UNC; UNF; UNEF; UNS

Internal

Defined by: ANSI B1.1:74
Tolerance class: 2A/2B

Mini L Style
5LI14UNTM...
5LI12UNTM...

Mini L Style

U Style

L Style

Insert Size	Pitch	Ordering Code	EDP No.		Toolholder Cutting Diameter D2 (Inch)
IC	TPI	Internal	VTX	VBX	Adjusted D2
5.0L (Mini L)	18	5LI18UNTM...	59722	59721	TM.SC...5L CTM.SC...5L
	16	5LI16UNTM...	59788	59787	
	14	5LI14UNTM...	59786	59785	
	12	5LI12UNTM...	59784	59783	

U Style

Insert Size		Pitch	Ordering Code	EDP No.		Toolholder Cutting Diameter D2 (Inch)
IC	L	TPI	Internal	VTX	VBX	* Adjusted D2
1/4"U	.43	14	2UI14UNTM...	50448	50447	TM2SC100W090-275-2U; TM3SC100W102-315-2U; TM4SC125W122-374-2U; TM2SC062C090-300-2U; TM3SC075C102-415-2U; TM4SC100C122-452-2U; CTM3SC075C102-433-2U; CTM4SC100C124-530-2U
		12	2UI12UNTM...	50441	50436	For 12UN change D2 to D2-.045

* Correct the toolholder cutting diameter D2 according to adjustment, as indicated in the above table.

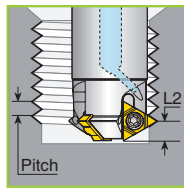

U Style
For Large Pitches

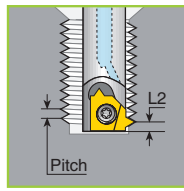

Mini-L Style
For Small Bores and Short L2

NPT

External / Internal

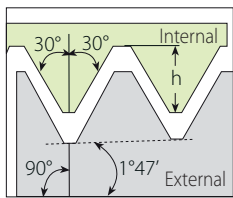

Defined by: USAS B2.1:1968
Tolerance class: Standard NPT

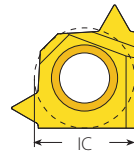

Mini L Style

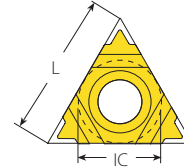

U Style

L Style



Insert Size	Pitch	Ordering Code	EDP No.		Toolholder Cutting Diameter D2 (Inch)	
IC	TPI	External/Internal			Toolholder	Adjusted D2
5.0L (Mini L)	18	5LEI18NPT-TM...	59724	59723	TM.SC...5L CTM.SC...5L	-

U Style



Insert Size		Pitch	Ordering Code			Toolholder Cutting Diameter D2 (Inch)			
IC	L	TPI	Internal/External	VTX	VBX	Toolholder	* Adjusted D2		
1/4"U	0.43	14	2UEI14NPT-TM...	50408	50404	TM1SC062W059-157-2U	.574		
						CTM1SC031C059-157-2U	.574		
						CTM1SC043C061-235-2U	.590		
		11.5	2UEI11.5NPT-TM...	50397	50391	50397	50391	TM2SC100W082-236-2U; CTM2SC056C082-256-2U; CTM2SC062C082-315-2U	.807
								TM2SC100W090-275-2U; TM2SC062C090-300-2U	.891
								TM3SC100W102-315-2U; TM3SC075C102-415-2U; CTM3SC075C102-433-2U	1.009
	TM4SC125W122-374-2U; TM4SC100C122-452-2U							1.206	
	CTM4SC100C124-530-2U							1.225	
	TM3SC125W143-374-3U; TM3SC125W144-570-3U; TM3SC100C143-512-3U							1.404	
	0.63	3UEI11.5NPTTM...	50461	50457	50461	50457	TM3SC112C146-565-3U	1.429	
							TM4SC 150W165-472-3U	1.620	
							TM4SC D169-050-3U	1.659	
TM5SC D208-075-3U							2.053		
TM3SC125W143-374-3U							1.404		
TM3SC125W144-570-3U									
TM3SC 100C143-512-3U									
3/8"U	0.63	8	3UEI8NPTTM...	50454	50449	TM3SC 112C146-565-3U	1.429		
						TM4SC 150W165-472-3U	1.620		
						TM4SC D169-050-3U	1.659		
		8	4UEI8NPT-TM...	50468	50467	50468	50467	TM5SC D208-075-3U	2.053
								TM6SCD346-100-4U	3.467
								TM7SCD435-150-4U	4.353
1/2"U	0.86	8	4UEI8NPT-TM...	50468	50467				

* Correct the toolholder cutting diameter D2 according to adjustment, as indicated in the above table.

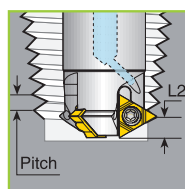

U Style
For Large Pitches

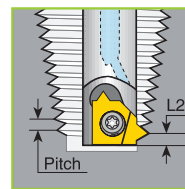

Mini-L Style
For Small Bores and Short L2

Trapez

Internal

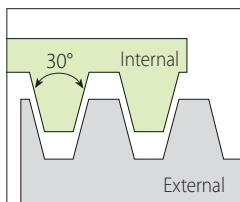

Defined by: DIN 103
Tolerance class: 7e/7H

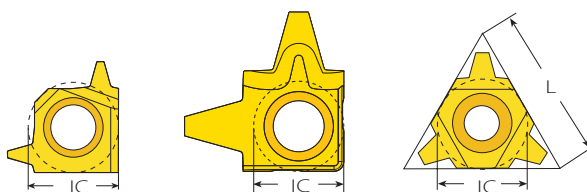

Mini L Style

3/8" L

U Style

L Style

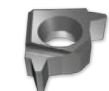

Insert Size	Pitch	Ordering Code	EDP No.		Application	
			VTX	VBX	Internal	Toolholder
5.0L (Mini L)	2.0	5LI2.0TR-1TM...	50359	50207	TR16x2, TR20x2	TM.SC...5L CTM.SC...5L
	2.0	5LI2.0TR-2TM...	50367	50361	TR18x2	
3/8" L	6.0	3LI6.0TR-1TM...	59509	59503	(TR30-36)x6	TM1SC100W085-200-3L CTM1SC050C085-295-3L
	6.0	3LI6.0TR-2TM...	59516	59515	(TR115-130)x6	TM7SCD315-100-3L
	7.0	3LI7.0TRTM...	59518	59517	(TR38-44)x7	TM2SC100W112-275-3L CTM2SC062C112-330-3L
	8.0	3LI8.0TR-1TM...	59571	59519	(TR46-52)x8	TM3SC125W132-350-3L CTM3SC075C132-443-3L
	8.0	3LI8.0TR-2TM...	59573	59572	(TR175-240)x8	TM7SCD315-100-3L

U Style



Insert Size		Pitch	Ordering Code	EDP No.		Application	
IC	L			VTX	VBX	Internal	Toolholder
1/4" U	.43	3.0	2UI3.0TR-1TM...	50383	50372	(TR22-TR30)x3	See pages 310-316
			2UI3.0TR-2TM...	50389	50386	(TR32-TR60)x3	
		4.0	2UI4.0TR-1TM...	50396	50394	(TR20-TR28)x4	
			2UI4.0TR-2TM...	50415	50399	(TR65-TR110)x4	
		5.0	2UI5.0TR-1TM...	50428	50417	TR22x5; TR28x5	
			2UI5.0TR-2TM...	50438	50431	TR24x5; TR26x5	

American ACME

Internal

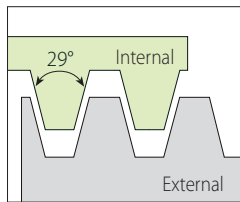

Defined by: ANSI B1.5: 1988
Tolerance class: 3G

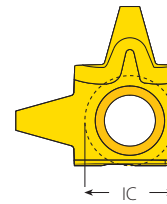

3/8" L

L Style



3/8" L

Insert Size IC	Pitch TPI	Ordering Code		EDP No.		Application	Toolholder
		Internal		VTX	VBX	Internal	
3/8" L	5	3LI5ACMETM...		59575	59574	1¼-5ACME	TM1SC100W085-200-3L CTM1SC 050C085-295-3L
		3LI4ACME-1TM...		59577	59576	1⅜-4ACME	
		3LI4ACME-2TM...		59579	59578	1½-4ACME	
	4	3LI4ACME-3TM...		59581	59580	1¾-4ACME	TM2SC100W112-275-3L CTM2SC062C112-330-3L
		3LI4ACME-4TM...		59583	59582	2-4ACME	
		3LI3ACME-1TM...		59585	59584	2¼-3ACME	
	3	3LI3ACME-2TM...		59587	59586	2½-3ACME	TM3SC125W132-350-3L CTM3SC075C132-443-3L
		3LI3ACME-3TM...		59589	59588	2¾-3ACME	

Stub ACME

Internal

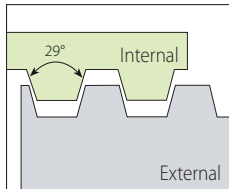

Defined by: ANSI B1.8: 1988
Tolerance class: 2G

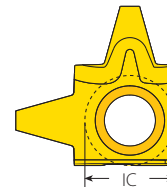

3/8" L

L Style



3/8" L

Insert Size IC	Pitch TPI	Ordering Code		EDP No.		Application	Toolholder
		Internal		VTX	VBX	Internal	
3/8" L	5	3LI5STACMETM...		59591	59590	1¼-5STACME	TM1SC100W085-200-3L CTM1SC050C085-295-3L
		3LI4STACME-1TM...		59593	59592	1⅜-4STACME	
		3LI4STACME-2TM...		59595	59594	1½-4STACME	
	4	3LI4STACME-3TM...		59597	59596	2-4STACME	TM3SC125W132-350-3L CTM3SC075C132-443-3L
		3LI3STACME-1TM...		59599	59598	2¼-3STACME	
		3LI3STACME-2TM...		59601	59600	2½-3STACME	
	3	3LI3STACME-3TM...		59603	59602	2¾-3STACME	

TMSD

American Buttress

Internal

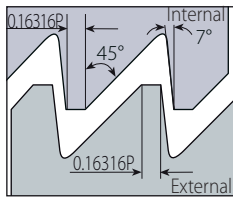

Defined by: ANSI B1.9.1973
Tolerance class: Class 2

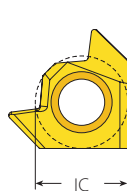

Mini L Style

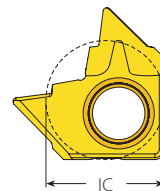

3/8" L

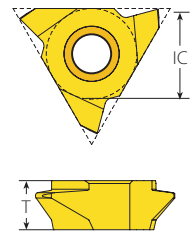

5/8 V

L Style

Insert Size	Pitch	Ordering Code	EDP No.		Application	
			IC	TPI	Internal	VTX
	5.0L (Mini L)	5LI16ABUT-TM...	59671	59670	.875"-4.0" ABUT	TM2SC 062W055-140-5L-ABUT CTM2SC 037C055-200-5L-ABUT
					1.25"-4.0" ABUT	TM3SC 075W072-180-5L-ABUT CTM3SC 055C072-256-5L-ABUT
		5LI12ABUT-TM...	59673	59672	.875"-6.0" ABUT	TM2SC 062W055-140-5L-ABUT CTM2SC 037C055-200-5L-ABUT
					1.25"-6.0" ABUT	TM3SC 075W072-180-5L-ABUT CTM3SC 055C072-256-5L-ABUT
		5LI10ABUT-TM...	59675	59674	.875"-16.0" ABUT	TM2SC 062W055-140-5L-ABUT CTM2SC 037C055-200-5L-ABUT
					1.25"-16.0" ABUT	TM3SC 075W072-180-5L-ABUT CTM3SC 055C072-256-5L-ABUT
	3/8" L	3LI16ABUT-TM...	59677	59676	1.75"-4.0" ABUT	TM2SC 100W104-315-3L-ABUT CTM2SC 075C104-450-3L-ABUT
					2.5"-4.0" ABUT	TM3SC 125W140-413-3L-ABUT
		3LI12ABUT-TM...	59679	59678	1.75"-6.0" ABUT	TM2SC 100W104-315-3L-ABUT CTM2SC 075C104-450-3L-ABUT
					2.5"-6.0" ABUT	TM3SC 125W140-413-3L-ABUT
		3LI10ABUT-TM...	59681	59680	1.75"-6.0" ABUT	TM2SC 100W104-315-3L-ABUT CTM2SC 075C104-450-3L-ABUT
					2.5"-6.0" ABUT	TM3SC 125W140-413-3L-ABUT
3LI8ABUT-TM...	59683	59682	1.75"-6.0" ABUT	TM2SC 100W104-315-3L-ABUT CTM2SC 075C104-450-3L-ABUT"		
			2.5"-6.0" ABUT	TM3SC 125W140-413-3L-ABUT		
3LI6ABUT-TM...	59685	59684	1.75"-6.0" ABUT	TM2SC 100W104-315-3L-ABUT CTM2SC 075C104-450-3L-ABUT		
			2.5"-6.0" ABUT	TM3SC 125W140-413-3L-ABUT		
					4.0"-6.0" ABUT	TM6SC D228-075-3L-ABUT

V Style

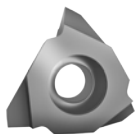

Insert Size	Pitch	Ordering Code	EDP No.		Application		
			IC	TPI	Internal	VTX	VBX
5/8" V	4	5VI4ABUT-TM...	59687	59686	.24	5.5"-24.0" ABUT	TM6SC D346-125-5V6-ABUT
	3	5VI3ABUT-TM...	59689	59688	.31	6.0"-24.0" ABUT	TM6SC D346-125-5V8-ABUT
	2.5	5VI2.5ABUT-TM...	59691	59690	.39	7.0"-24.0" ABUT	

API Round Casing & Tubing

Internal

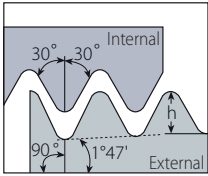

Defined by: API STD. 5B:1979
Tolerance class: Standard API RD

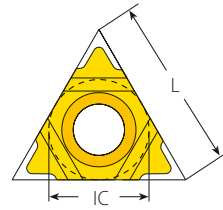

U Style



IC	Insert Size		Pitch	Ordering Code	EDP No.		Toolholder	Toolholder Cutting Diameter D2 (Inch)
	L Inch	TPI			Internal	VTX		VBX
1/4"U	.43	10	2UI10APIRDTM...	30158	30159	TM2SC100W090-275-2U	.844	
						TM2SC062C090-300-2U		
						TM3SC100W102-315-2U	.962	
3/8"U	.63	8	3UI8APIRDTM...	30160	30161	TM3SC075C102-415-2U		
						TM4SC125W122-374-2U	1.159	
						TM4SC100C122-452-2U		
						TM3SC125W143-374-3U	1.366	
						TM3SC125W144-570-3U		
						TM3SC100C143-512-3U		
						TM3SC112C146-565-3U	1.389	
TM4SC150W165-472-3U	1.583							
TM4SCD169-050-3U	1.622							
TM5SCD208-075-3U	2.016							

* Correct the toolholder cutting diameter D2 according to adjustment, as indicated in the above table.

Standard Toolholders - Weldon Shank (U Style)

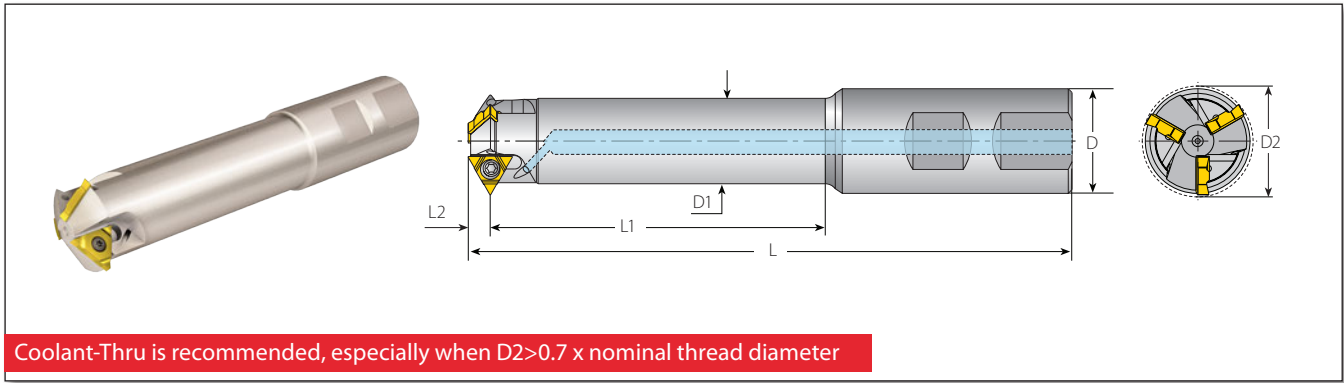

Weldon Shank for U Style Inserts

Insert Size	Ordering Code	EDP No.	Dimensions Inch							No. of Flutes	Spare Parts	
			L	L1	L2	D	D1	D2	Z			
1/4"U	TM1SC062W059-157-2U	67116	3.76	1.57		.625	.42	.58*	1	SN2T (70036)	Torx Key HK2T (70227)	
	TM2SC100W082-236-2U	67117	4.92	2.36		1.00	.63	.81*	2			
	TM2SC100W090-275-2U	67722	5.38	2.75	.21	1.00	.70	.91	2			
	TM3SC100W102-315-2U	67724	5.79	3.15		1.00	.80	1.02	3			
3/8"U	TM4SC125W122-374-2U	67725	6.37	3.74		1.25	1.01	1.22	4	SA3T (70028)	Torx Key HK3T (70228)	
	TM3SC125W143-374-3U	67742	6.45	3.74		1.25	1.14	1.44	3			
	TM3SC125W144-570-3U	67763	8.80	5.70	.32	1.25	1.10	1.44	3			
	TM4SC150W165-472-3U	67743	7.82	4.72		1.50	1.35	1.66	4	SN3T (70038)		

Weldon Shank (U Style) Applications

Thread Applications for Partial Profile Inserts

Toolholder	Min. Thread Dia.							
	D2	ISO Coarse	ISO Fine	UNC	UN/UNF/UNEF/UNS	BSP (G)	Partial 55°	Trapez
TM1SC062W059-157-2U	.58*	M18x2.5; M24x3.0	M16x0.5; M16x0.75; M16x1.0; M17x1.25; M17x1.5; M17x2.0	3/4-10	5/8-32UN; 5/8-28UN; 5/8-27UNS; 11/16-24UN; 11/16-20UN; 11/16-16UN; 3/4-14UNS; 3/4-12UN	3/8-19; 1/2-14; 1-11	11/16-14; 3/4-12; 7/8-11; 3/4-10; 7/8-9; 1-8; 1 1/8-7	TR22x3; TR24x3
TM2SC100W082-236-2U	.81*	M24x3.0; M30x3.5	M22x0.5; M22x0.75; M22x1.0; M23x1.25; M23x1.5; M23x2.0	1-8; 1 1/8-7; 1 3/8-6	7/8-32UN; 7/8-28UN; 7/8-27UNS; 7/8-24UNS; 1-20UNEF; 1-18UNS; 1 1/16-16UN; 1-14UNS; 1 1/16-12UN; 1-10UNS	3/4-14; 1-11	1-26; 1-20; 1-16; 1-12; 1-10; 1 1/8-9; 1-8; 1 1/8-7	(TR26- TR60)x3
TM2SC100W090-275-2U	.91	M27x3.0; M30x3.5; M36x4.0	M24x0.5; M24x0.75; M25x1.0; M25x1.25; M26x1.5; M26x2.0; M27x2.5	1 1/8-7	1-32UN; 1-28UN; 1-27UNS; 1-24UNS; 1-20UNEF; 1-18UNS; 1-16UN; 1-14UNS; 1-12UNF; 1 1/8-10UNS; 1 1/8-8UN	3/4-14; 1-11	1-26; 1-20; 1-16; 1 1/16-12; 1 1/8-9; 1 1/8-7	-
TM3SC100W102-315-2U	1.02	M30x3.5; M36x4.0	M27x0.5; M27x0.75; M28x1.0; M28x1.25; M28x1.5; M29x2.0; M30x2.5; M30x3.0	1 1/4-7; 1 3/8-6	1 1/8-28UN; 1 1/8-24UNS; 1 1/8-20UN; 1 1/8-18UNEF; 1 1/8-16UN; 1 1/8-14UNS; 1 1/8-12UNF; 1 1/4-10UNS; 1 3/16-8UN	7/8-14; 1-11	1 1/8-26; 1 1/8-20; 1 3/8-16; 1 3/8-12; 1 3/16-8; 1 1/4-7	-
TM4SC125W122-374-2U	1.22	M36x4.0	M32x0.5; M32x0.75; M33x1.0; M33x1.25; M33x1.5; M34x2.0; M34x2.5; M35x3.0; M36x3.5	1 1/2-6	1 3/16-28UN; 1 3/16-24UNS; 1 3/16-20UN; 1 3/16-18UNEF; 1 3/16-16UN; 1 3/16-14UNS; 1 3/16-12UNF; 1 3/8-10UNS; 1 3/8-8UN	1 1/8-11	1 3/8-26; 1 3/8-20; 1 3/8-16; 1 3/8-12; 1 7/16-8	-
TM3SC125W143-374-3U TM3SC125W144-570-3U	1.44	M42x4.5; M48x5.0; M56x5.5; M64x6.0	M39x1.5; M39x2.0; M40x2.5; M41x3.0; M42x3.5; M42x4.0	1 3/4-5; 2-4.5; 2 1/2-4	1 1/8-16UN; 1 1/8-14UNS; 1 1/8-12UN; 1 1/8-10UNS; 1 1/8-8UN; 1 1/8-6UN	1 1/4-11	1 5/8-16; 1 5/8-12; 1 5/8-8; 1 5/8-6; 1 3/4-5	-
TM4SC150W165-472-3U	1.66	M48x5.0; M56x5.5; M64x6.0	M45x1.5; M45x2.0; M46x2.5; M48x3.0; M48x3.5; M48x4.0	2-4.5; 2 1/2-4	1 3/4-16UN; 1 3/4-14UNS; 1 3/16-12UN; 1 3/16-8UN; 1 1/16-6UN	1 1/2-11	1 7/8-16; 1 7/8-12; 1 7/8-8; 2 1/4-6; 2-4.5	-

* For TR inserts use the CNC program (D2+.01").

Weldon Shank (U Style) Applications (con't)

Thread Applications for Full Profile Inserts (ISO & UN)

Toolholder	Toolholder Cutting Diameter D2 (Inch)		Pitch		Min. Thread Dia.	
	* Adjusted D2	mm	TPI	ISO Fine	UN/UNF/UNEF/UNS	
TM2SC100W090-275-2U	.866	1.5	-	M26x1.5	-	
	.860	2.0	-	M26x2.0	-	
	.864	-	14	-	1-14UNS	
	.860	-	12	-	1-12UNF	
TM3SC100W102-315-2U	.984	1.5	-	M28x1.5	-	
	.978	2.0	-	M29x2.0	-	
	.982	-	14	-	1 1/8-14UNF	
	.978	-	12	-	1 1/8-12UNF	
TM4SC125W122-374-2U	1.181	1.5	-	M33x1.5	-	
	1.175	2.0	-	M34x2.0	-	
	1.179	-	14	-	1 3/8-14UNS	
	1.175	-	12	-	1 3/8-12UNF	

Thread Applications for Full Profile Inserts (NPT)

Toolholder	Toolholder Cutting Diameter D2 (Inch)		Pitch	Cylindrical or Conical Pre-Drilled Hole	Cylindrical Pre-Drilled Hole
	* Adjusted D2	TPI		NPT Threading by 1 Radial Pass	**NPT Threading by 2 Radial Passes (50% / 50%)
TM1SC062W059-157-2U	.574	14		1/2-14NPT; 3/4-14NPT	-
TM2SC100W082-236-2U	.807	14		3/4-14NPT	-
TM2SC100W090-275-2U	.891	11.5		1-11.5NPT; 1 1/4-11.5NPT; 1 1/2-11.5NPT; 2-11.5NPT	-
TM3SC100W102-315-2U	1.009	11.5		1-11.5NPT; 1 1/4-11.5NPT; 1 1/2-11.5NPT; 2-11.5NPT	-
TM4SC125W122-374-2U	1.206	11.5		1 1/4-11.5NPT; 1 1/2-11.5NPT; 2-11.5NPT	-
TM3SC125W143-374-3U	1.404	11.5		1 1/4-11.5NPT; 1 1/2-11.5NPT; 2-11.5NPT	-
TM3SC125W144-570-3U					
TM3SC125W143-374-3U	1.404	8		-	2 1/2...10-8NPT
TM3SC125W144-570-3U					
TM4SC150W165-472-3U	1.620	11.5		1 1/2-11.5NPT; 2-11.5NPT	-
TM4SC150W165-472-3U	1.620	8		-	2 1/2...10-8NPT

** When the pre-drilled hole for 8NPT is conical, the thread can be machined in one pass.

Thread Applications for Full Profile Inserts (API Round)

Toolholder	Toolholder Cutting Diameter D2 (Inch)		Pitch	Cylindrical or Conical Pre-Drilled Hole (for cylindrical 2 radial passes 50%/50%; for conical one radial pass)	Conical Pre-Drilled Hole only (one pass)	
	* Adjusted D2	TPI		Thread Dia.		
TM2SC100W090-275-2U	.844	10		1.05x10APIRD (for UP TBG; UP TBG Long); 1.315...1.66x10APIRD (for TBG; UP TBG; UP TBG Long; Integral-Joint TBG)	-	
TM3SC100W102-315-2U	.962			1.66...2.875x10APIRD (for TBG; UP TBG; UP TBG Long; Integral-Joint TBG)		
TM4SC125W122-374-2U	1.159			1.66...3.5x10APIRD (for TBG; UP TBG; UP TBG Long; Integral-Joint TBG)		
TM3SC125W143-374-3U	1.366	8		2.375...13.375x8APIRD (for CSG; TBG; UP TBG; UP TBG Long); 4.5...5.5x8APIRD (for LCSG)	-	
TM3SC125W144-570-3U					2.375...20x8APIRD (for CSG; TBG; UP TBG; UP TBG Long); 4.5...7.625x8APIRD (for LCSG)	8.625...20x8APIRD (for LCSG)
TM4SC150W165-472-3U			1.583		2.875...20x8APIRD (for CSG; TBG; UP TBG; UP TBG Long); 4.5...7.625x8APIRD (for LCSG)	8.625x8APIRD (for LCSG)

* Correct the toolholder cutting diameter D2 according to adjustment, as indicated in the above table.

Standard Toolholders - Carbide Cylindrical Shank (U Style)

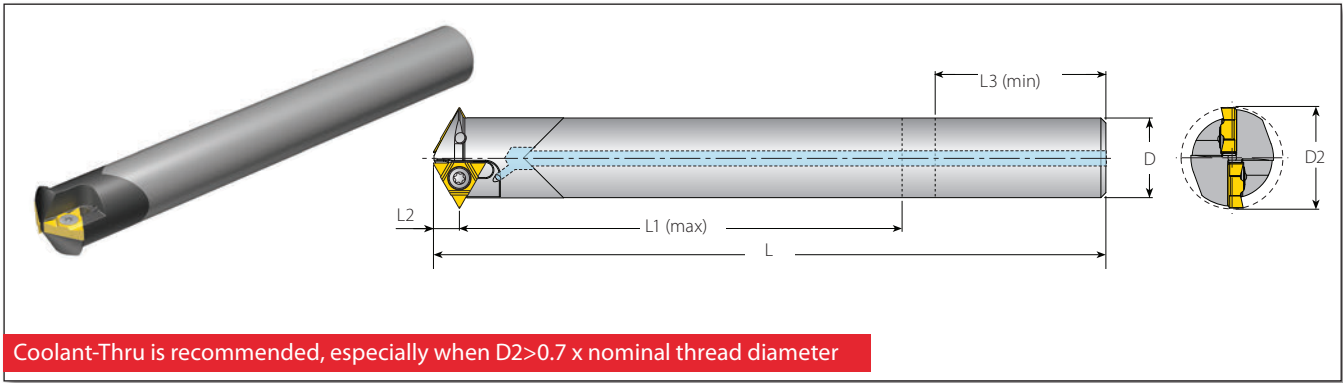

Carbide Cylindrical Shank for U Style Inserts

Insert Size	Ordering Code	EDP No.	Dimensions Inch							No. of Flutes	Spare Parts	
			L	L1 (max)	L2	L3 (min)	D	D2	Z		Insert Screw	Torx Key
IC												
1/4"U	CTM1SC031C059-157-2U	67121	4.30	1.57	.21	.65	.3125	.58*	1	SN2T (70036)	HK2T (70227)	
	CTM1SC043C061-235-2U	67123	4.72	2.35		.90	.4375	.60*	1			
	CTM2SC056C068-235-2U	67125	5.35	2.35	.13	1.15	.5625	.68**	2			
	CTM2SC056C082-256-2U	67122	5.38	2.56		1.15	.5625	.81*	2			
	CTM2SC062C082-315-2U	67124	5.30	3.15	.21	1.28	.625	.81*	2			
	CTM3SC075C102-433-2U	67129	6.50	4.33		1.57	.75	1.02*	3			
	CTM4SC100C124-530-2U	67128	7.60	5.30	1.81	1.00	1.24*	4				

* For TR inserts use the CNC program (D2+.010").
 ** To be used only with inserts 2UIDD60TM... or 2UIDM60TM...
 For insert 2UIDD60 TM... use the CNC program (D2+.028").

TMSD

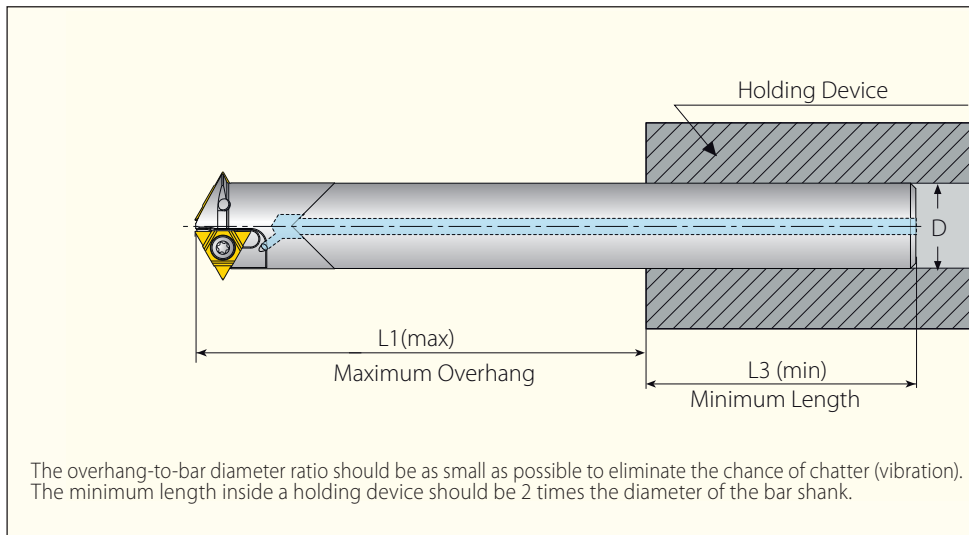

Carbide Cylindrical Shank (U Style) Applications

Thread Applications for Partial Profile Inserts

Toolholder	Min. Thread Dia.							
	D2	ISO Coarse	ISO Fine	UNC	UN/UNF/UNEF/UNS	BSP (G)	Partial 55°	Trapez
CTM1SC031C059-157-2U	.58*	M18x2.5; M24x3.0; M30x3.5; M36x4.0	M16x0.5; M16x0.75; M16x1.0; M17x1.25; M17x1.5; M17x2.0	¾-10; ¾-9; 1-8; 1½-7; 1¾-6	⅝-32UN; ⅝-28UN; ⅝-27UNS; 1⅛-24UNEF; 1⅛-20UN; 1⅛-16UN; ¾-14UNS; 1⅛-12UN	½-14; 1-11	1⅛-26; 1⅛-20; 1⅛-16; 1⅛-14; ¾-12; ⅝-11; ¾-10; ⅞-9; 1-8; 1½-7	TR22x3; TR24x3; TR20x4; TR22x5; TR24x5; TR26x5; TR28x5
CTM1SC043C061-235-2U	.60*	M18x2.5; M24x3.0	M16x0.5; M16x0.75; M16x1.0; M17x1.25; M17x1.5; M17x2.0	¾-10; ¾-9; 1-8	⅝-32UN; ⅝-28UN; ⅝-27UNS; 1⅛-24UNEF; 1⅛-20UN; 1⅛-16UN; ¾-14UNS; 1⅛-12UN	½-14; 1-11	1⅛-26; 1⅛-20; 1⅛-16; 1⅛-14; ¾-12; ⅝-11; ¾-10; ⅞-9	TR22x3; TR24x3
CTM2SC056C068-235-2U	.68**	M20x2.5; M22x2.5	M21x2.0	⅞-9	⅞-10UNS; 1⅜-12UN	-	-	-
CTM2SC056C082-256-2U	.81*	M24x3.0; M30x3.5; M36x4.0	M22x0.5; M22x0.75; M22x1.0; M23x1.25; M23x1.5; M23x2.0	1-8; 1½-7; 1¾-6	⅞-32UN; ⅞-28UN; ⅞-27UNS; ⅞-24UNS; ⅞-20UNEF; 1-18UNS; 1⅝-16UN; 1-14UNS; 1⅝-12UN; 1-10UNS	¾-14; 1-11	1-26; 1-20; 1-16; 1-12; 1-10; 1½-9; 1-8; 1½-7	(TR26-TR60)x3; TR28x4; (TR65-TR110)x4; TR28x5
CTM2SC062C082-315-2U	.81*	M24x3.0; M30x3.5	M22x0.5; M22x0.75; M22x1.0; M23x1.25; M23x1.5; M23x2.0	1-8; 1½-7; 1¾-6	⅞-32UN; ⅞-28UN; ⅞-27UNS; ⅞-24UNS; ⅞-20UNEF; 1-18UNS; 1⅝-16UN; 1-14UNS; 1⅝-12UN; 1-10UNS	¾-14; 1-11	1-26; 1-20; 1-16; 1-12; 1-10; 1½-9; 1-8; 1½-7	(TR26-TR60)x3
CTM3SC075C102-433-2U	1.02*	M30x3.5; M36x4.0	M27x0.5; M27x0.75; M28x1.0; M28x1.25; M28x1.5; M29x2.0; M30x2.5; M30x3.0	1¼-7; 1¾-6	1½-28UN; 1½-24UNS; 1½-20UN; 1½-18UNEF; 1½-16UN; 1½-14UNS; 1½-12UNF; 1¾-10UNS; 1⅞-8UN	⅞-14; 1-11	1½-26; 1½-20; 1¾-16; 1¾-12; 1¾-8; 1¼-7	(TR40-TR60)x3 (TR65-TR110)x4
CTM4SC100C124-530-2U	1.24*	M36x4.0	M32x0.5; M32x0.75; M33x1.0; M33x1.25; M33x1.5; M34x2.0; M34x2.5; M35x3.0; M36x3.5	1½-6	1⅝-28UN; 1½-24UNS; 1½-20UN; 1½-18UNEF; 1¾-16UN; 1¾-14UNS; 1¾-12UNF; 1¾-10UNS; 1⅞-8UN	1⅞-11	1⅞-26; 1⅞-20; 1⅞-16; 1⅞-12; 1⅞-8	(TR50-TR60)x3 (TR65-TR110)x4

* For TR inserts use the CNC program (D2+10").
 ** To be used only with inserts 2UIDD60TM... or 2UIDM60TM...
 For insert 2UIDD60 TM... use the CNC program (D2+.028").

Thread Applications for Full Profile Inserts (ISO & UN)

Toolholder	Toolholder Cutting Diameter D2 (Inch)	Pitch			Min. Thread Dia.	
		* Adjusted D2	mm	TPI	ISO Fine	UN/UNF/UNEF/UNS
CTM3SC075C102-433-2U	.984		1.5	-	M28x1.5	-
	.978		2.0	-	M29x2.0	-
	.982		-	14	-	1 1/8-14UNS
	.978		-	12	-	1 1/8-12UNF
CTM4SC100C124-530-2U	1.181		1.5	-	M33x1.5	-
	1.175		2.0	-	M34x2.0	-
	1.179		-	14	-	1 3/8-14UNS
	1.175		-	12	-	1 3/8-12UNF

* Correct the toolholder cutting diameter D2 according to adjustment, as indicated in the above table.

Thread Applications for Full Profile Inserts (NPT)

Toolholder	Toolholder Cutting Diameter D2 (Inch)	Pitch	Cylindrical or Conical Pre-Drilled Hole	
			* Adjusted D2	TPI
CTM1SC031C059-157-2U	.574	14	NPT Threading by 1 Radial Pass	
CTM1SC043C061-235-2U			NPT Threading by 2 Radial Passes (50% / 50%)	
CTM2SC056C082-256-2U	.807	14	1/2-14NPT; 3/4-14NPT	
CTM2SC062C082-315-2U			3/4-14NPT	
CTM3SC075C102-433-2U	1.009	11.5	1-11.5NPT; 1¼-11.5NPT; 1½-11.5NPT; 2-11.5NPT	
CTM4SC100C124-530-2U	1.206	11.5	1¼-11.5NPT; 1½-11.5NPT; 2-11.5NPT	

* Correct the toolholder cutting diameter D2 according to adjustment, as indicated in the above table.

TMSD

Standard Toolholders - Steel Cylindrical Shank (U Style)

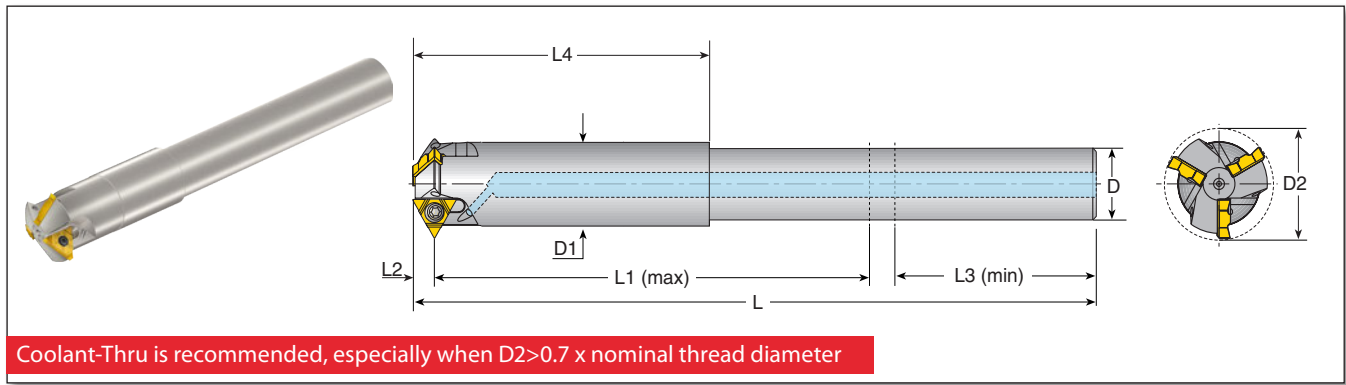

Steel Cylindrical Shank for U Style Inserts												Spare Parts		
Insert Size	Ordering Code	EDP No.	Dimensions Inch									No. of Flutes		
IC			L	L1 (max)	L2	L3 (min)	L4	D	D1	D2	Z	Insert Screw	Torx Key	
1/4"U	TM2SC062C090-300-2U	67744	5.60	3.00	.21	1.35	2.16	.625	.70	.91	2	SN2T (70036)	HK2T (70227)	
	TM3SC075C102-415-2U	67745	7.20	4.15	.21	1.57	-	.75	.75	1.02	3			
	TM4SC100C122-452-2U	67746	7.70	4.52	.21	1.80	-	1.00	1.00	1.22	4			
3/8"U	TM3SC100C143-512-3U	67747	8.35	5.12	.31	1.80	3.08	1.00	1.14	1.44	3	SA3T (70028)	HK3T (70228)	
	TM3SC112C146-565-3U	67762	8.75	5.65	.31	2.35	3.08	1.125	1.14	1.46	3			

Steel Cylindrical Shank (U Style) Applications

Thread Applications for Partial Profile Inserts

Toolholder	Min. Thread Dia.						
	D2	ISO Coarse	ISO Fine	UNC	UN/UNF/UNEF/UNS	BSP (G)	Partial 55°
TM2SC062C090-300-2U	.91	M27x3.0; M30x3.5; M36x4.0	M24x0.5; M25x0.75; M25x1.0; M25x1.25; M26x1.5; M26x2.0; M27x2.5	1 1/8-7	1-32UN; 1-28UN; 1-27UN; 1-24UNS; 1-20UNEF; 1-18UNS; 1-16UN; 1-14UNS; 1 1/16-12UN; 1 1/8-10UNS; 1 1/8-8UN	3/4-14; 1-11	1-26; 1-20; 1 1/8-16; 1 1/8-12; 1 1/8-9; 1 1/8-7
TM3SC075C102-415-2U	1.02	M30x3.5; M36x4.0	M27x0.5; M27x0.75; M28x1.0; M28x1.25; M28x1.5; M29x2.0; M30x2.5; M30x3.0	1 1/4-7; 1 1/8-6	1 1/8-28UN; 1 1/8-24UNS; 1 1/8-20UN; 1 1/8-18UNEF; 1 1/8-16UN; 1 1/8-14UNS; 1 1/8-12UNF; 1 1/8-10UNS; 1 1/8-8UN	7/8-14; 1-11	1 1/8-26; 1 1/8-20; 1 1/8-16; 1 1/8-12; 1 1/8-8; 1 1/4-7
TM4SC100C122-452-2U	1.22	M36x4.0	M32x0.5; M32x0.75; M33x1.0; M33x1.25; M33x1.5; M34x2.0; M34x2.5; M35x3.0; M36x3.5	1 1/2-6	1 1/8-28UN; 1 1/8-24UNS; 1 1/2-20UN; 1 1/2-18UNEF; 1 1/2-16UN; 1 1/2-14UNS; 1 1/2-12UNF; 1 1/2-10UNS; 1 1/2-8UN	1 1/8-11	1 1/8-26; 1 1/8-20; 1 1/8-16; 1 1/8-12; 1 1/8-8
TM3SC100C143-512-3U	1.44	M42.5x4.5; M48x5.0; M56x5.5; M64x6.0	M39x1.5; M40x2.5; M41x3.0; M42x3.5; M42x4.0	1 3/4-5; 2-4.5; 2 1/2-4	1 1/8-16UN; 1 1/8-14UNS; 1 1/8-12UN; 1 1/8-10UNS; 1 1/8-8UN; 1 1/8-6UN	1 1/4-11	1 1/8-16; 1 1/8-12; 1 1/8-8; 1 1/8-6; 1 1/4-5
TM3SC112C146-565-3U	1.46	M42.5x4.5; M48x5.0; M56x5.5; M64x6.0	M39x1.5; M40x2.5; M41x3.0; M42x3.5; M42x4.0	1 3/4-5; 2-4.5; 2 1/2-4	1 1/8-16UN; 1 1/8-14UNS; 1 1/8-12UN; 1 1/8-10UNS; 1 1/8-8UN; 1 1/8-6UN	1 1/4-11	1 1/8-16; 1 1/8-12; 1 1/8-8; 1 1/8-6; 1 1/4-5

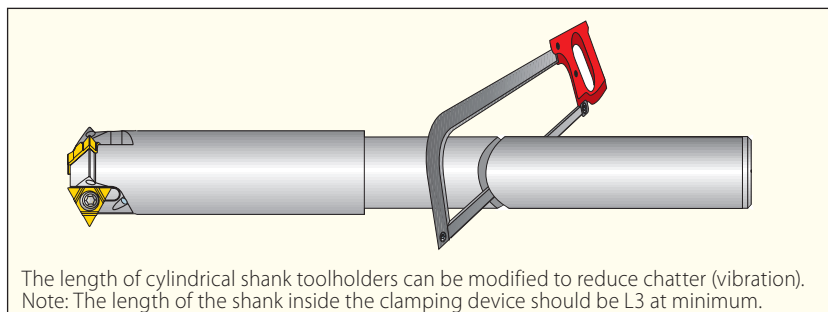

Steel Cylindrical Shank (U Style) Applications (con't)

Thread Applications for Full Profile Inserts (ISO & UN)

Toolholder	Toolholder Cutting Diameter D2 (Inch)	Pitch		Min. Thread Dia.	
	* Adjusted D2	mm	TPI	ISO Fine	UN/UNF/UNEF/UNS
TM2SC062C090-300-2U	.866	1.5	-	M26x1.5	-
	.860	2.0	-	M26x2.0	-
	.864	-	14	-	1-14UNS
	.860	-	12	-	1-12UNF
TM3SC075C102-415-2U	.984	1.5	-	M28x1.5	-
	.978	2.0	-	M29x2.0	-
	.982	-	14	-	1 1/8-14UNS
	.978	-	12	-	1 1/8-12UNF
TM4SC100C122-452-2U	1.181	1.5	-	M33x1.5	-
	1.175	2.0	-	M34x2.0	-
	1.179	-	14	-	1 3/8-14UNS
	1.175	-	12	-	1 3/8-12UNF

Thread Applications for Full Profile Inserts (NPT)

Toolholder	Toolholder Cutting Diameter D2 (Inch)	Pitch	Cylindrical or Conical Pre-Drilled Hole	Cylindrical Pre-Drilled Hole
	* Adjusted D2	TPI	NPT Threading by 1 Radial Pass	**NPT Threading by 2 Radial Passes (50% / 50%)
TM2SC062C090-300-2U	.891	11.5	1-11.5NPT; 1 1/4-11.5NPT; 1 1/2-11.5NPT; 2-11.5NPT	-
TM3SC075C102-415-2U	1.009	11.5	1-11.5NPT; 1 1/4-11.5NPT; 1 1/2-11.5NPT; 2-11.5NPT	-
TM4SC100C122-452-2U	1.206	11.5	1 1/4-11.5NPT; 1 1/2-11.5NPT; 2-11.5NPT	-
TM3SC100C143-512-3U	1.404	11.5	1 1/4-11.5NPT; 1 1/2-11.5NPT; 2-11.5NPT	-
TM3SC112C146-565-3U				
TM3SC100C143-512-3U	1.404	8	-	2 1/2...10-8NPT
TM3SC112C146-565-3U				

** When the pre-drilled hole for 8NPT is conical, the thread can be machined in one pass.

Thread Applications for Full Profile Inserts (API Round)

Toolholder	Toolholder Cutting Diameter D2 (Inch)	Pitch	Cylindrical or Conical Pre-Drilled Hole (for cylindrical 2 radial passes 50%/50%; for conical one radial pass)	Conical Pre-Drilled Hole only (one pass)
	* Adjusted D2	TPI	Thread Dia.	
TM2SC062C090-300-2U	.844	10	1.05x10APIRD (for UP TBG; UP TBG Long); 1.315...1.66x10APIRD (for TBG; UP TBG; UP TBG Long; Integral-Joint TBG)	-
TM3SC075C102-415-2U	.962		1.66...2.875x10APIRD (for TBG; UP TBG; UP TBG Long; Integral-Joint TBG)	
TM4SC100C122-452-2U	1.159		1.66...3.5x10APIRD (for TBG; UP TBG; UP TBG Long; Integral-Joint TBG)	
TM3SC100C143-512-3U	1.366	8	2.375...20x8APIRD (for CSG; TBG; UP TBG; UP TBG Long); 4.5...7.625x8APIRD (for LCSG)	8.625...9.625x8APIRD (for LCSG)
TM3SC112C146-565-3U	1.389			8.625...20x8APIRD (for LCSG)

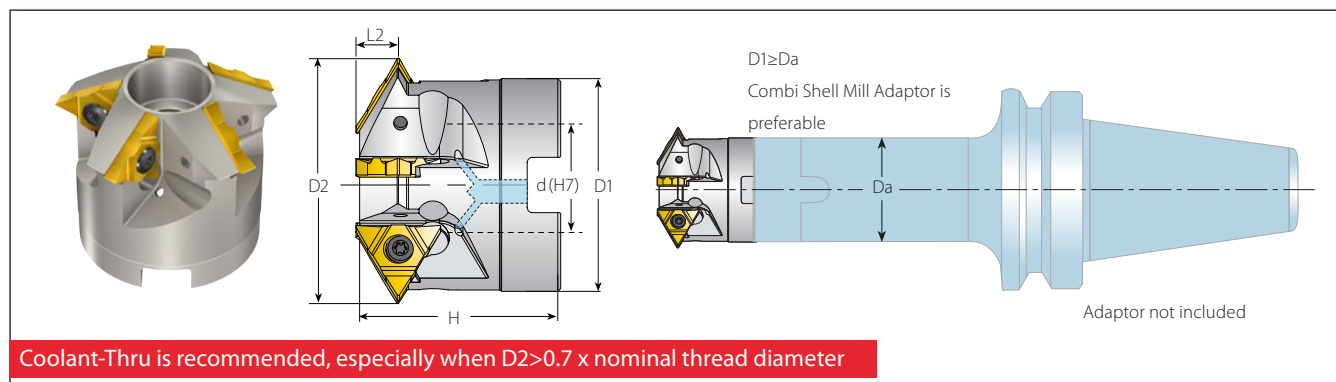

* Correct the toolholder cutting diameter D2 according to adjustment, as indicated in the above table.

Shell Mill (U Style)



Shell Mill for U Style Inserts

Spare Parts

Insert Size	Ordering Code	EDP No.	Dimensions Inch					No. of Flutes			
IC			D1	D2	d(H7)	H	L2	Z	Insert Screw	Torx Key	Holder Screw
3/8"U	TM4SC-D169-050-3U	67750	1.38	1.69	.50	1.58	.31	4	SN3T (70038)	HK3T (70228)	1/4-28x1.25 (70222)
	TM5SC-D208-075-3U	67751	1.77	2.09	.75	1.58	.31	5			3/8-24x1.25 (70223)
1/2"U	TM6SC-D346-100-4U	67752	2.99	3.47	1.0	2.00	.39	6	SA4T (70032)	HK4T (70241)	1/2-20x1.5 (70224)
	TM8SC-D435-150-4U	67761	3.83	4.35	1.5	2.17	.39	8			3/4-16x1.75 (70226)

Shell Mill (U Style) Applications

Thread Applications for Partial Profile Inserts

Toolholder	Min. Thread Dia.						
	D2	ISO Coarse	ISO Fine	UNC	UN/UNF/UNEF/UNS	BSP (G)	Partial 55°
TM4SC-D169-050-3U	1.69	M56x5.5 M64x6.0	M45x1.5; M48x2.0 M48x3.0; M48x4.0	2-4.5; 2½ - 4	1 ¹³ / ₁₆ -16UN; 1 ⁷ / ₈ -14UNS; 1 ¹³ / ₁₆ -12UN; 1 ⁷ / ₈ -10UNS; 1 ⁷ / ₈ -8UN; 1 ¹⁵ / ₁₆ -6UN	1½ - 11	1 ⁷ / ₈ -16; 1 ⁷ / ₈ -12; 1 ⁷ / ₈ -8; 2 ¹ / ₈ -6; 2- 4.5; 2¼ - 4
TM5SC-D208-075-3U	2.09	M64x6.0	M55x1.5; M56x2.0; M58x3.0; M58x4.0	2½ - 4	2¼-16UN; 2¼-14UNS; 2¼-12UN; 2¼-10UNS; 2¼-8UN; 2 ³ / ₈ -6UN	2 - 11	2¼-16; 2¼-12; 2 ³ / ₈ -8; 2 ³ / ₈ -6; 3-5; 3½-4.5
TM6SC-D346-100-4U	3.47	-	M95x6; M125x8	4 - 4	4¼-4UN	3½ - 11	4¼-4; 4-3
TM8SC-D435-150-4U	4.35	-	M120x6; M125x8	-	4 ³ / ₄ -4UN	-	-

Shell Mill (U Style) Applications (con't)

Thread Applications for Full Profile Inserts (NPT)

Toolholder	Toolholder Cutting Diameter D2 (Inch)	Pitch	Cylindrical or Conical Pre-Drilled Hole	Cylindrical Pre-Drilled Hole
	* Adjusted D2	TPI	NPT Threading by 1 Radial Pass	**NPT Threading by 2 Radial Passes (50% / 50%)
TM4SC-D169-050-3U	1.659	11.5	1½-11.5NPT; 2-11.5NPT	-
TM4SC-D169-050-3U	1.659	8	-	2½...10-8NPT
TM5SC-D208-075-3U	2.053	11.5	2-11.5NPT	-
TM5SC-D208-075-3U	2.053	8	-	2½...10-8NPT
TM6SC-D346-100-4U	3.467	8	3½"...160D-8NPT	160D...240D-8NPT
TM7SC-D435-150-4U	4.353	8	4"...160D-8NPT	160D...240D-8NPT

** When the pre-drilled hole for 8NPT is conical, the thread can be machined in one pass.

Thread Applications for Full Profile Inserts (API Round)

Toolholder	Toolholder Cutting Diameter D2 (Inch)	Pitch	Cylindrical or Conical Pre-Drilled Hole (for cylindrical 2 radial passes 50%/50%; for conical one radial pass)	Conical Pre-Drilled Hole only (one pass)
	* Adjusted D2	TPI	Thread Dia.	
TM4SC-D169-050-3U	1.622	8	2.875...20x8APIRD (for CSG; TBG; UP TBG; UP TBG Long); 4.5...7.625x8APIRD (for LCSG)	8.625...20x8APIRD (for LCSG)
TM5SC-D208-075-3U	2.016		3.5...20x8APIRD (for CSG; TBG; UP TBG; UP TBG Long); 4.5...7.625x8APIRD (for LCSG)	

* Correct the toolholder cutting diameter D2 according to adjustment, as indicated in the above table.

Standard Toolholders - Weldon Shank (L Style - Mini L)

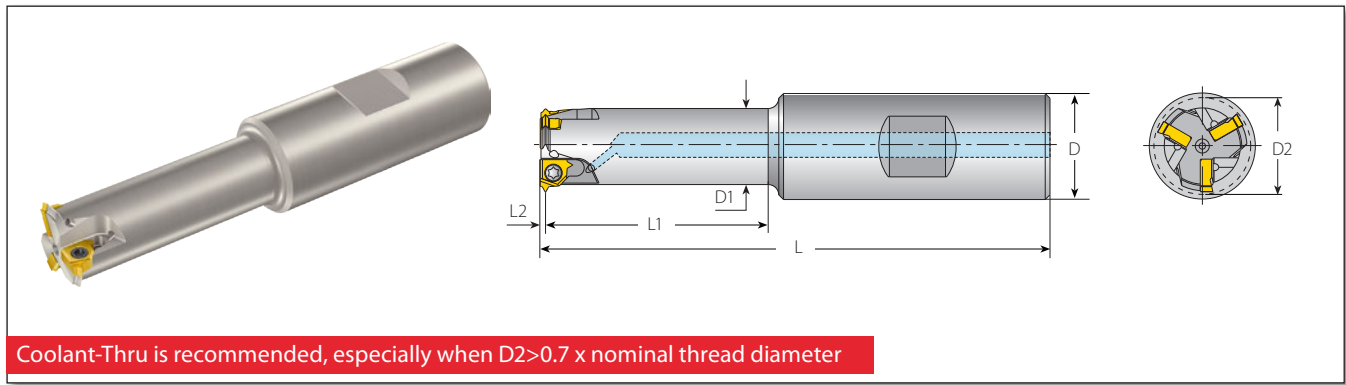

Weldon Shank for Mini-L Style Inserts

Insert Size	Ordering Code	EDP No.	Dimensions Inch							No. of Flutes	Spare Parts	
			L	L1	L2	D	D1	D2	Z		Insert Screw	Torx Key
IC mm												
5.0L (Mini L)	TM1SC062W051-114-5L	67111	3.20	1.14		.625	.38	.51	1	SN5LTR	K7T	
	TM2SC062W054-130-5L	67114	3.40	1.30	.04	.625	.41	.53	2			
	TM3SC075W069-165-5L	67115	3.80	1.65		.75	.56	.70	3			
	TM2SC062W055-140-5L-ABUT	67780	3.50	1.40		.625	.41	.55	2			
	TM3SC075W072-180-5L-ABUT	67781	4.00	1.80	.074	.75	.56	.72	3			

Weldon Shank (L Style - Mini L) Applications

Thread Applications for Partial Profile Inserts

Toolholder		Min. Thread Dia.						
	D2	ISO Coarse	ISO Fine	UNC	UN/UNF/UNEF/UNS	BSP (G)	Partial 55°	Trapez
TM1SC062W051-114-5L	.51	M16x2	M14x0.5; M14x0.75; M14.5x1.0; M15x1.5; M17x2.0	5/8-11	5/16-32UN; 5/16-28UN; 9/16-27UNS; 5/16-24UNEF; 5/8-20UN; 5/8-18UNF; 5/8-16UN; 5/8-14UNS; 5/8-12UN	3/8-19	5/8-14	TR16X2; TR18X2
TM2SC062W054-130-5L	.53	M16x2	M15x0.5; M15x0.75; M15x1.0; M16x1.5; M17x2.0	-	5/8-32UN; 5/8-28UN; 5/8-27UNS; 5/8-24UNEF; 5/8-20UN; 5/8-18UNF; 5/8-16UN; 5/8-14UNS; 11/16-12UN	3/8-19	11/16-14	TR16X2; TR18X2
TM3SC075W069-165-5L	.70	-	M19x0.5; M19x0.75; M19x1.0; M20x1.5; M20x2.0	-	3/4-32UN; 3/4-28UN; 7/8-27UNS; 3/4-24UNS; 13/16-20UNEF; 7/8-18UNS; 13/16-16UN; 7/8-14UNF; 13/16-12UN	1/2-14	-	TR20X2

Thread Applications for Full Profile Inserts (ISO, UN, NPT)

Toolholder		Min. Thread Dia.		
	D2	ISO Fine	UN/UNF/UNEF/UNS	NPT
TM1SC062W051-114-5L	.51	M14.5x1.0; M15x1.5; M17x2.0	5/8-18UNF; 5/8-16UN; 5/8-14UNS; 5/8-12UN	3/8-18NPT
TM2SC062W054-130-5L	.53	M15x1.0; M16x1.5; M17x2.0	5/8-18UNF; 5/8-16UN; 5/8-14UNS; 11/16-12UN	3/8-18NPT
TM3SC075W069-165-5L	.70	M19x1.0; M20x1.5; M20x2.0	7/8-18UNS; 13/16-16UN; 7/8-14UNF; 13/16-12UN	-

Thread Applications for Full Profile American Buttress Inserts

Toolholder		Thread Dia.	
	D2	American Buttress	
TM2SC062W055-140-5L-ABUT	.55	(0.875"-4")-16; (0.875"-6")-12; (0.875"-16")-10	
TM3SC075W072-180-5L-ABUT	.72	(1.25"-4")-16; (1.25"-6")-12; (1.25"-16")-10	

TMSD

Standard Toolholders - Carbide Cylindrical Shank (L Style - Mini L)

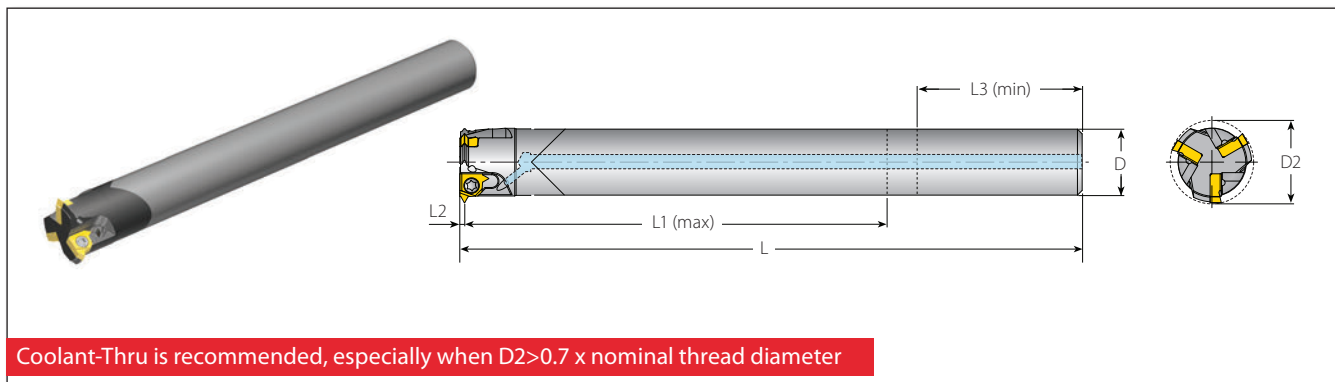

Carbide Cylindrical Shank for Mini-L Style Inserts

Insert Size	Ordering Code	EDP No.	Dimensions Inch							No. of Flutes	Spare Parts	
			L	L1 (max)	L2	L3 (min)	D	D2	Z		Insert Screw	Torx Key
IC												
5.0L (Mini L)	CTM1SC037C051-169-5L	67118	4.30	1.69		.80	.375	.51	1	SN5LTR (72007)	Torx Key (70026)	
	CTM2SC037C053-197-5L	67119	4.30	1.97	.04	.80	.375	.53	2			
	CTM3SC056C069-255-5L	67120	5.20	2.55		1.15	.562	.70	3			
	CTM2SC037C055-200-5L-ABUT	67784	4.30	2.00		.87	.375	.55	2			
	CTM3SC055C072-256-5L-ABUT	67785	5.20	2.56	.074	1.18	.550	.72	3			

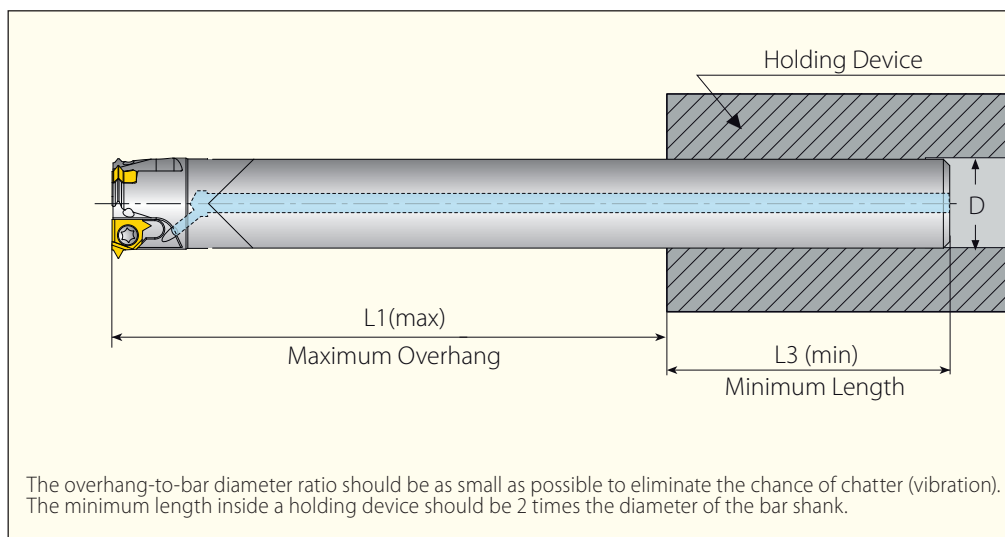

Carbide Cylindrical Shank (L Style - Mini L) Applications

Thread Applications for Partial Profile Inserts

Toolholder		Min. Thread Dia.							
	D2	ISO Coarse	ISO Fine	UNC	UN/UNF/UNEF/UNS	BSP (G)	Partial 55°	Trapez	
CTM1SC037C051-169-5L	.51	M16x2	M14x0.5; M14x0.75; M14.5x1.0; M15x1.5; M17x2.0	5/8-11	5/16-32UN; 3/16-28UN; 3/16-27UNS; 3/16-24UNEF; 5/16-20UN; 5/16-18UNF; 5/16-16UN; 5/16-14UNS; 5/16-12UN	3/8-19	5/8-14	TR16X2; TR18X2	
CTM2SC037C053-197-5L	.53	M16x2	M15x0.5; M15x0.75; M15x1.0; M16x1.5; M17x2.0	-	3/8-32UN; 3/8-28UN; 3/8-27UNS; 3/8-24UNEF; 3/8-20UN; 3/8-18UNF; 3/8-16UN; 3/8-14UNS; 1/16-12UN	3/8-19	1/16-14	TR16X2; TR18X2	
CTM3SC056C069-255-5L	.70	-	M19x0.5; M19x0.75; M19x1.0; M20x1.5; M20x2.0	-	3/4-32UN; 3/4-28UN; 7/8-27UNS; 3/4-24UNF; 13/16-20UNEF; 7/8-18UNF; 13/16-16UN; 7/8-14UNF; 13/16-12UN	1/2-14	-	TR20X2	

Thread Applications for Full Profile Inserts (ISO, UN, NPT)

Toolholder		Min. Thread Dia.		
	D2	ISO Fine	UN/UNF/UNEF/UNS	NPT
CTM1SC037C051-169-5L	.51	M14.5x1.0; M15x1.5; M17x2.0	5/8-18UNF; 5/8-16UN; 5/8-14UNS; 5/8-12UN	3/8-18NPT
CTM2SC037C053-197-5L	.53	M15x1.0; M16x1.5; M17x2.0	5/8-18UNF; 5/8-16UN; 5/8-14UNS; 1/16-12UN	3/8-18NPT
CTM3SC056C069-255-5L	.70	M19x1.0; M20x1.5; M20x2.0	7/8-18UNS; 13/16-16UN; 7/8-14UNF; 13/16-12UN	-

Thread Applications for Full Profile American Buttress Inserts



Toolholder		Thread Dia.	
	D2	American Buttress	
CTM2SC037C055-200-5L-ABUT	.55	(0.875"-4")-16; (0.875"-6")-12; (0.875"-16")-10	
CTM3SC055C072-256-5L-ABUT	.72	(1.25"-4")-16; (1.25"-6")-12; (1.25"-16")-10	

TMSD

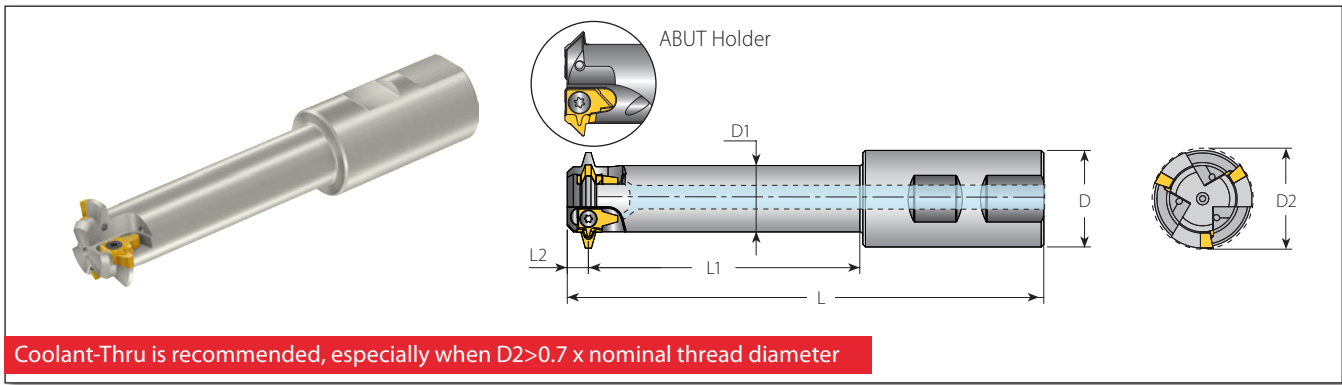
Standard Toolholders - Weldon Shank (L Style - 3/8" L)



Weldon Shank for 3/8" L Style Inserts

Insert Size	Ordering Code	EDP No.	Dimensions Inch							No. of Flutes	Spare Parts	
			L	L1	L2	D	D1	D2	Z			
3/8" L	Toolholder											
	TM1SC100W085-200-3L	67135	4.60	2.00		1.00	.50	.85	1	SN3T (70038)	HK3T (70228)	
	TM2SC100W112-275-3L	67136	5.32	2.75	.276	1.00	.71	1.12	2	SA3T (70028)		
	TM3SC125W132-350-3L	67137	6.22	3.50		1.25	.87	1.32	3	SN3T (70038)		
	TM2SC100W104-315-3L-ABUT	67782	5.70	3.15		1.00	.79	1.04	2			
	TM3SC125W140-413-3L-ABUT	67783	6.75	4.13	.185	1.25	1.10	1.40	3	SA3T (70028)		

Weldon Shank (L Style - 3/8" L) Applications

Thread Applications for Partial Profile Inserts

Toolholder	Min. Thread Dia.			
	D2	Trapez	American ACME	Stub ACME
TM1SC100W085-200-3L	.85	(TR30-36)x6	1¼-5; 1⅜-4; 1½-4	1¼-5; 1⅜-4; 1½-4
TM2SC100W112-275-3L	1.12	(TR38-44)x7	1¾-4	-
TM3SC125W132-350-3L	1.32	(TR46-52)x8	2-4; 2¼-3; 2½-3; 2¾-3	2-4; 2¼-3; 2½-3; 2¾-3



Thread Applications for Full Profile American Buttress Inserts

Toolholder	Thread Dia.	
	D2	American Buttress
TM2SC 100W104-315-3L-ABUT	1.04	(1.75"-4")-16; (1.75"-6")-12; (1.75"-6")-10; (1.75"-6")-8; (1.75"-6")-6
TM3SC 125W140-413-3L-ABUT	1.40	(2.5"-4")-16; (2.5"-6")-12; (2.5"-6")-10; (2.5"-6")-8; (2.5"-6")-6

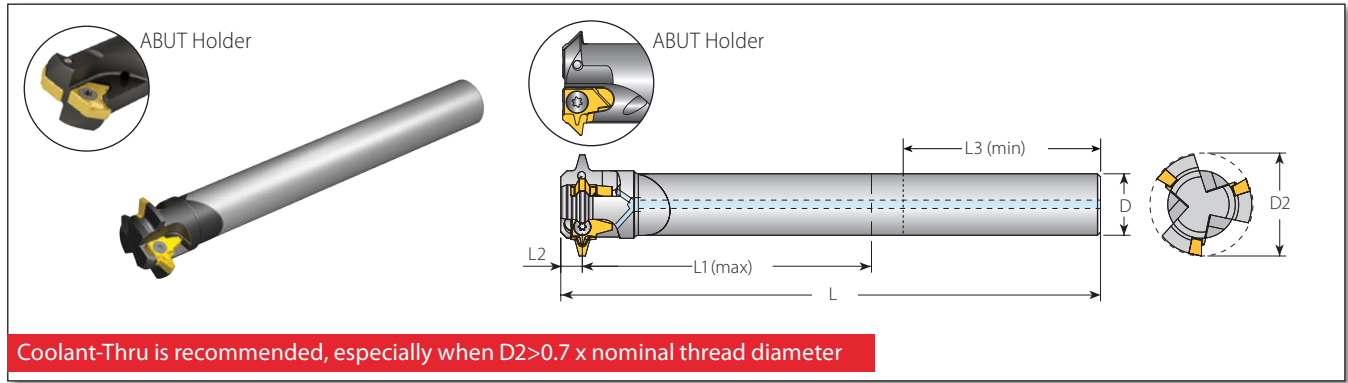
Standard Toolholders - Carbide Cylindrical Shank (L Style - 3/8" L)



Carbide Cylindrical Shank for 3/8" L Style Inserts

Carbide Cylindrical Shank for 3/8" L Style Inserts										Spare Parts		
Insert Size	Ordering Code	EDP No.	Dimensions Inch							No. of Flutes		
IC	Toolholder		L	L1(max)	L2	L3(min)	D	D2	Z	Insert Screw	Torx Key	
3/8" L	CTM1SC050C085-295-3L	67132	4.53	2.95		1.58	.50	.85	1	SN3T (70038)	HK3T (70228)	
	CTM2SC062C112-330-3L	67133	6.10	3.30	.28	1.81	.625	1.12	2	SA3T (70028)		
	CTM3SC075C132-443-3L	67134	6.60	4.43		1.81	.75	1.32	3	SN3T (70038)		
	CTM2SC075C104-450-3L-ABUT	67786	6.75	4.35	.19	1.57	.75	1.04	2	SA3T (70028)		

Carbide Cylindrical Shank (L Style - 3/8" L) Applications

Thread Applications for Partial Profile Inserts

Toolholder	Min. Thread Dia.			
	D2	Trapez	American ACME	Stub ACME
CTM1SC050C085-295-3L	.85	(TR30-36)x6	1¼-5; 1⅝-4; 1½-4	1¼-5; 1⅝-4; 1½-4
CTM2SC062C112-330-3L	1.12	(TR38-44)x7	1¾-4	-
CTM3SC075C132-443-3L	1.32	(TR46-52)x8	2-4; 2¼-3; 2½-3; 2¾-3	2-4; 2¼-3; 2½-3; 2¾-3

Thread Applications for Full Profile American Buttress Inserts

Toolholder	Thread Dia.	
	D2	American Buttress
CTM2SC075C104-450-3L-ABUT	1.04	(1.75"-4")-16; (1.75"-6")-12; (1.75"-6")-10; (1.75"-6")-8; (1.75"-6")-6

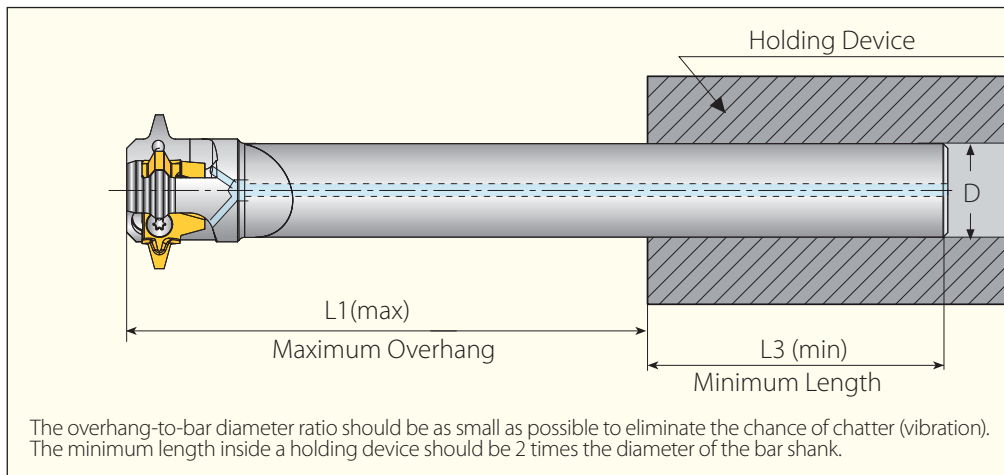

TMSD

Shell Mill (L Style - 3/8" L)

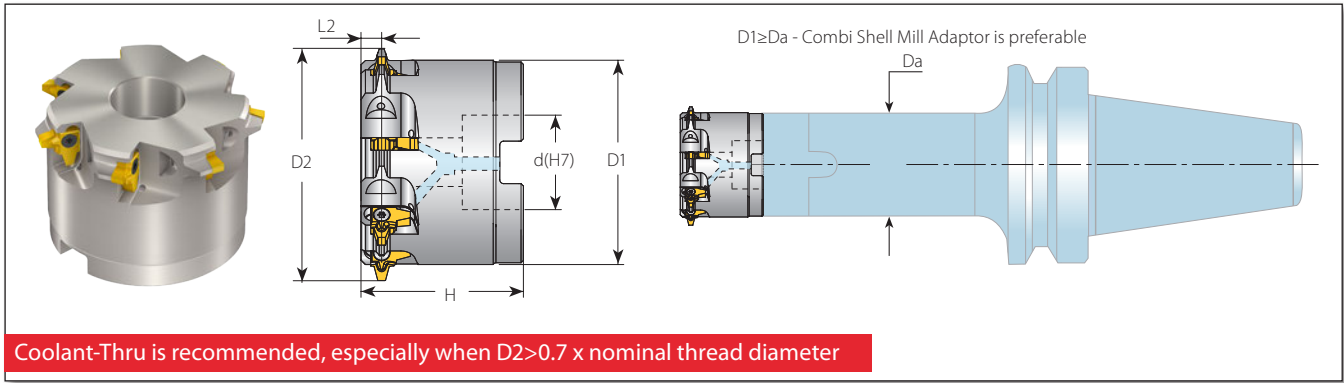

Shell Mill for 3/8" L Style Inserts

Insert Size	Ordering Code	EDP No.	Dimensions Inch						No. of Flutes	Spare Parts		
			D1	D2	d(H7)	H	L2	Z		Insert Screw	Torx Key	Holder Screw
3/8" L	TM7SC-D315-125-3L	67775	2.72	3.15	1.25	2.16	.276	7	SA3T (70028)	HK3T (70228)	5/8-18UNx1 1/2 (70037)	
	TM6SC-D228-075-3L-ABUT	67788	2.01	2.28	.75	1.58	.185	6			3/8-24x1.25 (70223)	

TMSD

Shell Mill (L Style - 3/8" L) Applications

Thread Applications for Partial Profile Inserts

Toolholder	Min. Thread Dia.			
	D2	Trapez	American ACME	Stub ACME
TM7SC-D315-125-3L	3.15	(TR115-TR130)x6; (TR175-TR240)x8	-	-



Thread Applications for Full Profile American Buttress Inserts

Toolholder	Thread Dia.	
	D2	American Buttress
TM6SC-D228-075-3L-ABUT	2.28	(4.0"-6")-12; (4.0"-6")-10; (4.0"-6")-8; (4.0"-6")-6

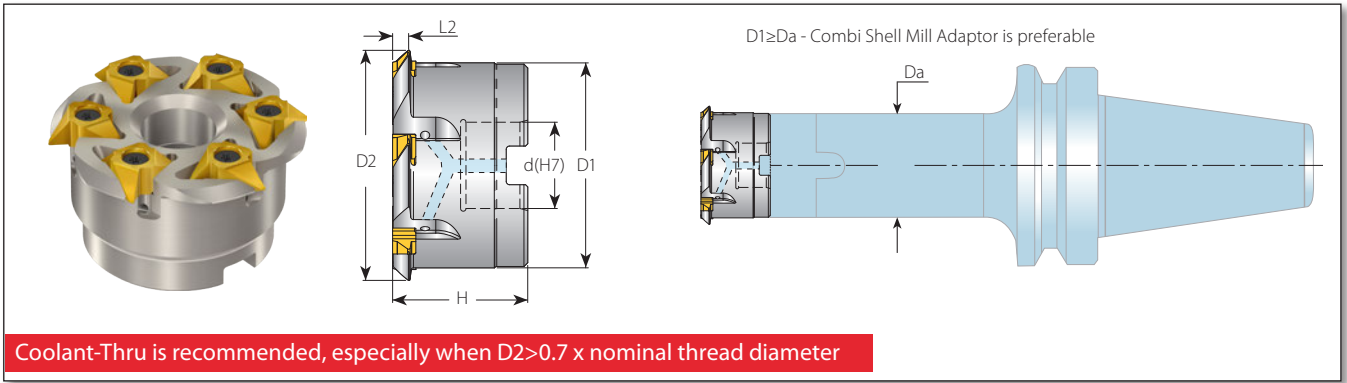
Shell Mill (5/8" V Style)



Shell Mill for 5/8" V Style Inserts

Shell Mill for 5/8" V Style Inserts									Spare Parts			
Insert Size	Ordering Code	EDP No.	Dimensions Inch				No. of Flutes					
IC	Toolholder		D1	D2	d(H7)	H	L2	Z	Insert	Insert Screw	Torx Key	Holder Screw
5/8"V	TM6SC-D346-125-5V6-ABUT	67768	2.85	3.46	1.25	1.92	.21	6	5V14ABUT-TM...	SA5 (70033)	HK5T (70011)	5/8-18UNx1 1/2 (70037)
	TM6SC-D346-125-5V8-ABUT	67789	2.85	3.46	1.25	2.07	.33	6	5V12.5ABUT-TM...			
						2.00	.28		5V13ABUT-TM...			

Shell Mill (5/8" V Style) Applications

Thread Applications for Full Profile American Buttress Inserts

Toolholder	D2	Thread Dia.
		American Buttress
TM6SC-D346-125-5V6-ABUT	3.46	(5.0"-24")-4
TM6SC-D346-125-5V8-ABUT	3.46	(6.0"-24")-3; (7.0"-24")-2.5

TMSD

Standard Toolholders - Steel Cylindrical Shank (A Style)

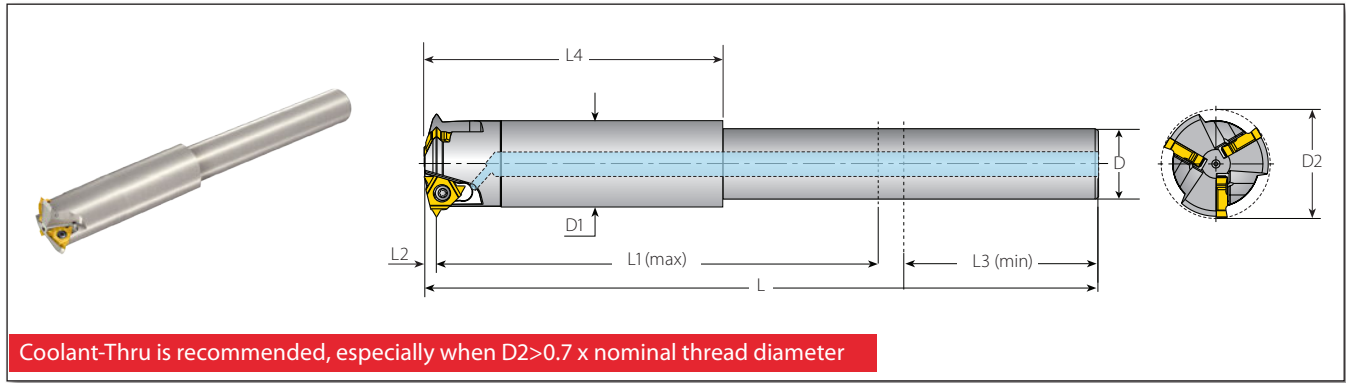

Steel Cylindrical Shank for A-Style Inserts

Insert Size	Ordering Code	EDP No.	Dimensions Inch								No. of Flutes	Spare Parts	
			L	L1(max)	L2	L3(min)	L4	D	D1	D2		Z	Insert Screw
1/4"A	TM3SC075C102-415-2A	67748	7.20	4.15	.12	1.57	-	.75	.75	1.02	3	SN2T(70036)	HK2T(70227)
3/8"A	TM3SC100C138-512-3A	67749	8.35	5.12	.16	1.80	3.08	1.00	1.11	1.39	3	SA3T(70028)	HK3T(70228)

TMSD

Steel Cylindrical Shank (A Style) Applications

Thread Applications for Partial Profile Inserts

Toolholder	D2	Min. Thread Dia.				
		ISO Coarse	ISO Fine	UNC	UN/UNF/UNEF/UNS	BSP (G)
TM3SC075C102-415-2A	1.02	-	M28x1.5; M29x2.0; M30x2.5; M30x3.0	-	1 1/8-16UN; 1 1/8-14UNS; 1 3/16-12UN; 1 1/4-10UNS; 1 3/16-8UN	-
TM3SC100C138-512-3A	1.39	-	M38x2.0; M39x2.5; M39x3.0; M40x4.0	-	1 1/8-12UN; 1 1/8-10UNS; 1 1/8-8UN; 1 1/8-6UN	-

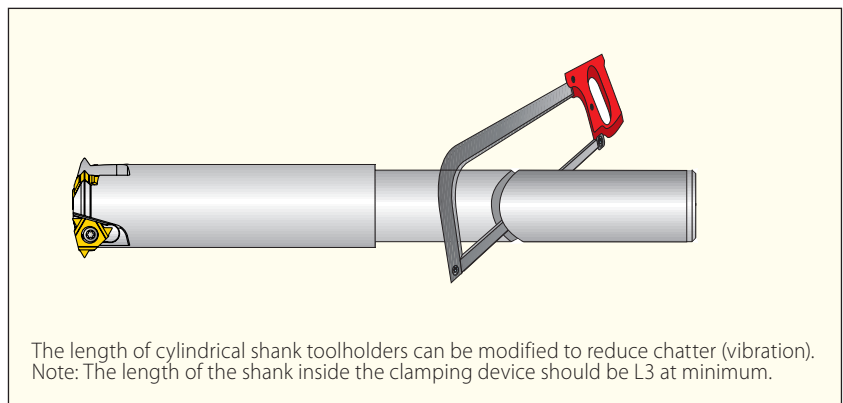

Recommended Grades, Cutting Speeds Vc [ft/min] and Feed f [inch/tooth]

Material Group	Vargus No.	Material	Hardness Brinell HB	Vc [ft/min]		Feed* f [inch/tooth] by Cutting Dia. (D2)			
				VBX	VTX	.51-.91	.94-1.65	Shell Mill	
P Steel	1	Unalloyed Steel	Low Carbon (C=0.1-0.25%)	125	328-689	295-590	.0079-.0126	.0118-.0197	.0118-.0295
	2		Medium Carbon (C=0.25-0.55%)	150	328-590	295-558	.0079-.0126	.0118-.0197	.0118-.0295
	3		High Carbon (C=0.55-0.85%)	170	328-558	295-525	.0059-.0091	.0098-.0138	.0098-.0205
	4	Low Alloy Steel (alloying elements ≤5%)	Non Hardened	180	197-295	295-508	.0067-.011	.011-.0177	.011-.0264
	5		Hardened	275	262-492	262-525	.0059-.011	.0098-.0177	.0098-.0264
	6		Hardened	350	230-459	230-492	.0059-.0098	.0098-.0157	.0098-.0236
	7	High Alloy Steel (alloying elements >5%)	Annealed	200	197-426	230-377	.0059-.0087	.0079-.0118	.0079-.0177
	8		Hardened	325	230-361	197-328	.0051-.0083	.0071-.0118	.0071-.0177
	9	Cast Steel	Low Alloy (alloying elements <5%)	200	328-558	328-558	.0059-.0087	.0079-.0118	.0079-.0177
	10		High Alloy (alloying elements >5%)	225	230-394	230-426	.0047-.0087	.0067-.0118	.0067-.0177
M Stainless Steel	11	Stainless Steel Ferritic	Non Hardened	200	328-558	394-590	.0059-.0087	.0087-.0134	.0087-.0197
	12		Hardened	330	328-558	394-590	.0063-.0091	.0083-.0126	.0083-.0189
	13	Stainless Steel Austenitic	Austenitic	180	230-459	328-459	.0059-.0098	.0098-.0157	.0098-.0236
	14		Super Austenitic	200	230-459	328-459	.0047-.0079	.0067-.0102	.0067-.0154
	15	Stainless Steel Cast Ferritic	Non Hardened	200	230-459	328-459	.0063-.0094	.0098-.0146	.0098-.0217
	16		Hardened	330	230-459	328-459	.0047-.0079	.0067-.0102	.0067-.0154
	17	Stainless Steel Cast Austenitic	Austenitic	200	230-394	328-394	.0059-.0087	.0079-.0118	.0079-.0177
	18		Hardened	330	230-394	328-394	.0047-.0079	.0067-.0102	.0067-.0154
K Cast Iron	28	Malleable Cast Iron	Ferritic (short chips)	130	197-426	328-394	.0063-.0094	.0098-.0146	.0098-.0217
	29		Pearlitic (long chips)	230	197-394	262-328	.0059-.0087	.0079-.0118	.0079-.0177
	30	Grey Cast Iron	Low Tensile Strength	180	197-426	262-328	.0059-.0087	.0087-.0134	.0087-.0197
	31		High Tensile Strength	260	197-328	262-328	.0059-.0087	.0079-.0118	.0079-.0177
	32	Nodular Sg Iron	Ferritic	160	197-410	262-328	.0039-.0079	.0059-.0098	.0059-.0146
	33		Pearlitic	260	164-295	197-295	.0059-.0087	.0079-.0118	.0079-.0177
N Non-Ferrous Metals	34	Aluminium Alloys Wrought	Non Aging	60	328-820		.0118-.0197	.0236-.0394	.0236-.0591
	35		Aged	100	328-590		.011-.0197	.0197-.0354	.0197-.0472
	36	Aluminium Alloys	Cast	75	492-1312		.011-.0197	.0197-.0354	.0197-.0472
	37		Cast & Aged	90	492-918		.0098-.0157	.0157-.0236	.0157-.0354
	38	Aluminium Alloys	Cast Si 13-22%	130	262-492		.011-.0197	.0197-.0354	.0197-.0472
	39	Copper and Copper Alloys	Brass	90	394-689	328-656	.0118-.0197	.0236-.0394	.0236-.0591
40	Bronze and Non Leaded Copper		100	394-689	328-656	.011-.0197	.0197-.0354	.0197-.0472	
S Heat Resistant Material	19	High Temperature Alloys	Annealed (iron based)	200	66-148	66-131	.0035-.0059	.0047-.0087	.0047-.013
	20		Aged (iron based)	280	66-98	66-98	.0028-.0051	.0039-.0079	.0039-.0118
	21		Annealed (nickel or cobalt based)	250	49-66	49-66	.0031-.0059	.0031-.0079	.0031-.0118
	22		Aged (nickel or cobalt based)	350	33-49	33-49	.0031-.0059	.0031-.0079	.0031-.0118
	23	Titanium Alloys	Pure 99.5 Ti	400Rm	230-459	230-394	.0028-.0051	.0039-.0079	.0039-.0118
24	α+β alloys		1050Rm	66-164	66-164	.0028-.0051	.0039-.0079	.0039-.0118	
H Hardened Material	25	Extra Hard Steel	Hardened & Tempered	45-50HRc	49-148	49-148	.002-.0047	.002-.0071	.002-.0106
	26			51-55HRc	49-131	49-131	.002-.0047	.002-.0071	.002-.0106

* When using a Shell Mill toolholder, the feed can be increased by 50%.
 * For 3/8"L it is recommended to machine in two passes and decrease the feed by 40%.

Grades

Grade	Application
VBX	TiCN coated carbide grade. Excellent grade for Steels and General Use.
VTX	TiAlN coated carbide grade. Ideal for Stainless Steels.

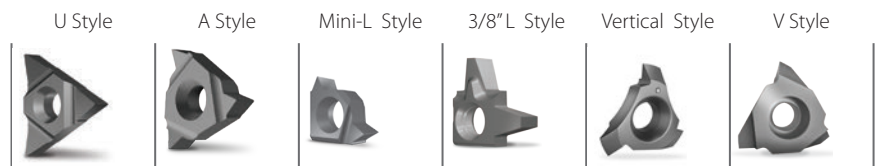



TM Solid

Solid Carbide Thread Milling Tools

Vardex Ordering Code System

■ TM Solid Carbide

HC		19	141	L03	-	I	24	UNC	TM		VTH
1	2	3	4	5		6	7	8	9	10	11

1 - Line	2 - No. of Teeth	3 - Shank Dia.	4 - Cutting Dia.	5 - Tool Cutting Length	6 - Type of Tool
HC - Helicool HCR - Helicool R HCC - Helicool C H - Helical S - Straight Flutes D - Deep Threading or MilliPro	1T - 1 Tooth 3T - 3 Teeth (MilliPro) 2L - 2 Teeth LH (MilliPro HD)	12 - 1/8" 19 - 3/16" 25 - 1/4" 31 - 5/16" 37 - 3/8" 50 - 1/2" 63 - 5/8" 75 - 3/4"	.028-.746	Up to 3Do	E - External I - Internal EI - External + Internal

7 - Pitch	8 - Standard	9 - System	10 - No. of Flutes	11 - Carbide Grade																						
Full Profile - Pitch Range <table border="1"> <tr> <th>mm</th> <th>TPI</th> </tr> <tr> <td>0.25-6.0</td> <td>80 - 4.5</td> </tr> </table> Partial Profile - Pitch Range <table border="1"> <tr> <th></th> <th>mm</th> <th>TPI</th> </tr> <tr> <td>TA</td> <td>0.5-0.8</td> <td>32-56</td> </tr> <tr> <td>TB</td> <td>0.5-1.0</td> <td>24-56</td> </tr> <tr> <td>TC</td> <td>1.0-1.50</td> <td>16-24</td> </tr> <tr> <td>TD</td> <td>1.0-1.75</td> <td>14-24</td> </tr> <tr> <td>TF</td> <td>0.5-1.25</td> <td>20-48</td> </tr> </table>	mm	TPI	0.25-6.0	80 - 4.5		mm	TPI	TA	0.5-0.8	32-56	TB	0.5-1.0	24-56	TC	1.0-1.50	16-24	TD	1.0-1.75	14-24	TF	0.5-1.25	20-48	60 - Partial Profile 60° ISO - ISO Metric UN - American UN UNC - UN Coarse UNF - UN Fine UNEF - UN Extra Fine UNJ - UNJ MJ - MJ BSW - Whitworth Coarse BSP - BSP BSF - Whitworth Fine BSPT - BSPT NPT - NPT ANPT - ANPT NPTF - NPTF NPS - NPS PG - PG TP60 - Taper 60° TP55 - Taper 55°	TM TML - Extra Long	3 - 3 Flutes 5 - 5 Flutes * For straight flutes only.	VTS VTH
mm	TPI																									
0.25-6.0	80 - 4.5																									
	mm	TPI																								
TA	0.5-0.8	32-56																								
TB	0.5-1.0	24-56																								
TC	1.0-1.50	16-24																								
TD	1.0-1.75	14-24																								
TF	0.5-1.25	20-48																								

■ HTC Thriller

HTC	M6	1.0	2D	VTN
1	2	3	4	5

1 - Line	2 - Thread Diameter	3 - Pitch	4 - Thread Length	5 - Carbide Grade
HTC - Thriller	M6 - M12	1 - 1.75mm	2D 2.5D	VTN VTS

Miniature Threads MilliPro

MilliPro &
MilliPro EL
From 1-72UNF (M1.6x0.35)



MilliPro HD
Up to 62 HRC

MilliPro Dental
From 0-80UNF (M1.0x0.25)

Long Thread Deep Threading

Full Profile

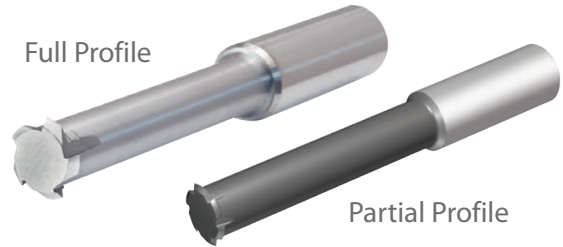

Partial Profile

Up to 3XDo

Normal Use Straight Flutes

Taper
For Bone Plate Applications
From Pitch 0.3-0.6mm



From No.8-36UNF (M4.5x0.75)

Heavy Duty Helicool



From No.10-32UNF (M3x0.5)

Radial Coolant Helicool-R (HCR)



From No.10-32UNF (M6x1.0)

Helicool and Chamfer Helicool-C (HCC)



From No.10-32UNF (M6x1.0)

Economical Tool He-Lex

Taper
For Bone Plate Applications
From Pitch 0.3-0.6mm



From No.10-32UNF (M3x0.5)

Drill, Thread and Chamfer HTC



From M6x1.0

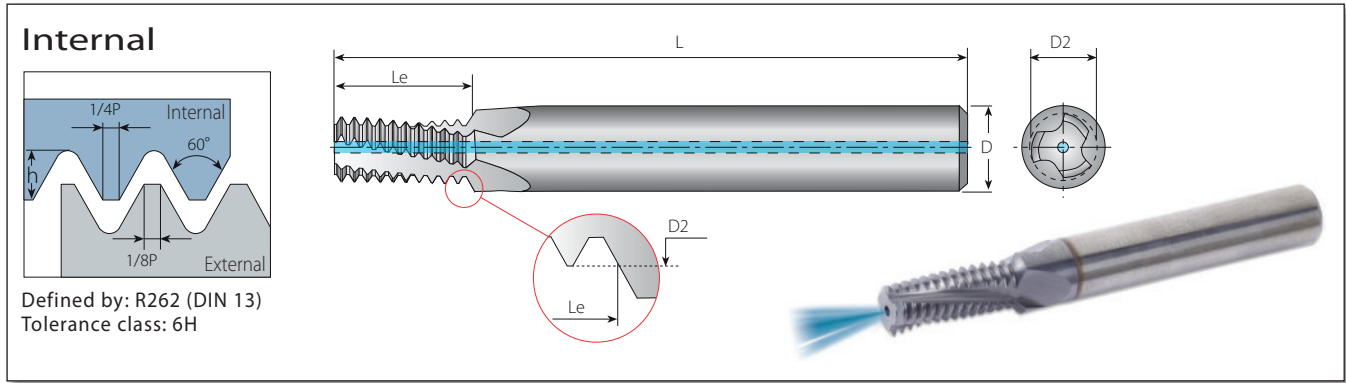

Defined by: R262 (DIN 13)
Tolerance class: 6H

Helical Flutes with Thru-Hole Coolant

1.5 x Do (Le ≤ 1.5 x Thread Diameter)

Thread		Pitch	Ordering Code	EDP No.	Dimensions Inch				No. of Flutes	Teeth	Bore Dia.*
M Coarse	M Fine	mm	Internal	VTH	D	D2	L	Le	Z	Zt	Inch
M3x0.5	M3.5-M16x0.5	0.5	HC19094L01-I0.50ISOTM...	80337	3/16	.094	1.772	.187	3	9	.098
M4x0.7		0.7	HC19124L02-I0.70ISOTM...	80355	3/16	.124	1.772	.262	3	9	.129
M5x0.8		0.8	HC19159L02-I0.80ISOTM...	80356	3/16	.159	2.244	.299	3	9	.165
M6x1.0	M8-M40x1.0	1.0	HC25189L03-I1.00ISOTM...	80343	1/4	.189	2.244	.374	3	9	.197
M8x1.25		1.25	HC31256L05-I1.25ISOTM...	80357	5/16	.256	2.402	.524	3	10	.268
M10x1.5	M12-M48x1.5	1.5	HC37323L06-I1.50ISOTM...	80346	3/8	.323	2.874	.620	3	10	.335
M12x1.75		1.75	HC37370L07-I1.75ISOTM...	80358	3/8	.370	2.874	.724	4	10	.405
M14x2.0	M17-M80x2.0	2.0	HC50457L08-I2.00ISOTM...	80351	1/2	.457	2.874	.827	4	10	.472
M16x2.0	M17-M80x2.0	2.0	HC63535L09-I2.00ISOTM...	80353	5/8	.535	3.622	.984	4	12	.551

Helical Flutes with Thru-Hole Coolant

2 x Do (Le ≤ 2 x Thread Diameter)

Thread		Pitch	Ordering Code	EDP No.	Dimensions Inch				No. of Flutes	Teeth	Bore Dia.*
M Coarse	M Fine	mm	Internal	VTH	D	D2	L	Le	Z	Zt	Inch
M3x0.5	M3.5-M16x0.5	0.5	HC19094L02-I0.50ISOTM...	80336	3/16	.094	1.772	.246	3	12	.098
	M4x0.5	0.5	HC19126L03-I0.50ISOTM...	80338	3/16	.126	1.772	.325	3	16	.138
	M5x0.5	0.5	HC25165L04-I0.50ISOTM...	80339	1/4	.165	2.244	.404	3	20	.177
M4x0.7		0.7	HC19124L03-I0.70ISOTM...	80284	3/16	.124	1.772	.344	3	12	.129
	M6x0.75	0.75	HC25197L04-I0.75ISOTM...	80340	1/4	.197	2.244	.487	3	16	.209
M5x0.8		0.8	HC19159L04-I0.80ISOTM...	80341	3/16	.159	2.244	.425	3	13	.165
M6x1.0	M8-M40x1.0	1.0	HC25189L04-I1.00ISOTM...	80342	1/4	.189	2.244	.492	3	12	.197
	M8x1.0	1.0	HC31264L06-I1.00ISOTM...	80344	5/16	.264	2.402	.650	3	16	.276
	M10x1.0	1.0	HC37343L08-I1.00ISOTM...	80285	3/8	.343	2.874	.807	3	20	.354
	M12x1.0	1.0	HC50421L09-I1.00ISOTM...	80286	1/2	.421	2.874	.965	4	24	.433
M8x1.25		1.25	HC31256L06-I1.25ISOTM...	80287	5/16	.256	2.402	.664	3	13	.268
	M10x1.25	1.25	HC37335L08-I1.25ISOTM...	80345	3/8	.335	2.874	.812	3	16	.346
M10x1.5	M12-M48x1.5	1.5	HC37323L07-I1.50ISOTM...	80288	3/8	.323	2.874	.797	3	13	.335
	M12x1.5	1.5	HC37370L09-I1.50ISOTM...	80347	3/8	.370	2.874	.974	4	16	.413
	M14x1.5	1.5	HC50469L11-I1.50ISOTM...	80348	1/2	.469	3.150	1.152	4	19	.492
	M16x1.5	1.5	HC63547L12-I1.50ISOTM...	80349	5/8	.547	3.150	1.270	4	21	.571
M12x1.75		1.75	HC37370L09-I1.75ISOTM...	80350	3/8	.370	2.874	.999	4	14	.405
M14x2.0	M17-M80x2.0	2.0	HC50457L11-I2.00ISOTM...	80289	1/2	.457	3.150	1.142	4	14	.472
M16x2.0	M17-M80x2.0	2.0	HC63535L12-I2.00ISOTM...	80352	5/8	.535	3.622	1.299	4	16	.551
M18x2.5		2.5	HC63583L14-I2.50ISOTM...	80354	5/8	.583	3.622	1.427	4	14	.598
M20x2.5		2.5	HC75673L16-I2.50ISOTM...	80290	3/4	.673	4.016	1.624	4	16	.687
M24x3.0		3.0	HC75746L19-I3.00ISOTM...	80359	3/4	.746	4.016	1.949	4	16	.827

*Bore diameter applies to smallest thread dia.

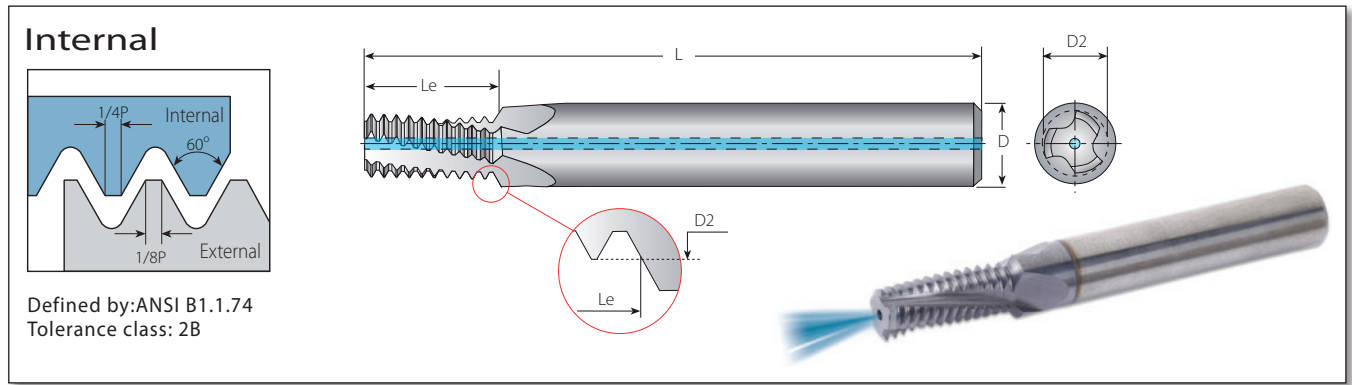

Helical Flutes with Thru-Hole Coolant

1.5 x Do (Le ≤ 1.5 x Thread Diameter)

Thread			Pitch	Ordering Code	EDP No.	Dimensions Inch				No. of Flutes	Teeth	Bore Dia.*
UNC	UNF	UNEF	TPI	Internal	VTH	D	D2	L	Le	Z	Zt	Inch
No.10-24	5/16"; 3/8"x24	9/16"-11/16"x24	24	HC19141L03-I24UNCTM...	80360	3/16	.141	1.772	.312	3	7	.150
No.12-24	5/16"; 3/8"x24	9/16"-11/16"x24	24	HC25163L03-I24UNCTM...	80361	1/4	.163	2.244	.354	3	8	.177
1/4"x20	7/16"; 1/2"x20	3/4"-1"x20	20	HC25192L03-I20UNCTM...	80362	1/4	.192	2.244	.375	3	7	.201
5/16"x18	9/16"; 5/8"x18	11/16"-1 11/16"x18	18	HC31242L04-I18UNCTM...	80363	5/16	.242	2.402	.472	3	8	.260
3/8"x16	3/4"x16		16	HC31301L05-I16UNCTM...	80364	5/16	.301	2.402	.594	3	9	.315
7/16"x14	7/8"x14		14	HC37354L06-I14UNCTM...	80365	3/8	.354	2.874	.678	3	9	.370
1/2"x13			13	HC50407L08-I13UNCTM...	80366	1/2	.407	3.150	.808	4	10	.429
9/16"x12	1"-1 1/2"x12		12	HC50465L08-I12UNCTM...	80367	1/2	.465	3.150	.875	4	10	.484

Helical Flutes with Thru-Hole Coolant

2 x Do (Le ≤ 2 x Thread Diameter)

Thread			Pitch	Ordering Code	EDP No.	Dimensions Inch				No. of Flutes	Teeth	Bore Dia.*
UNC	UNF	UNEF	TPI	Internal	VTH	D	D2	L	Le	Z	Zt	Inch
	No.10-32	No.12-3/8"x32	32	HC19150L03-I32UNFTM...	80291	3/16	.150	1.772	.391	3	12	.157
		No.12-3/8"x32	32	HC25173L04-I32UNEFTM...	80292	1/4	.173	2.244	.453	3	14	.185
	No.12; 1/4"x28	7/16"; 1/2"x28	28	HC25169L04-I28UNFTM...	80293	1/4	.169	2.244	.446	3	12	.181
	1/4"x28	7/16"; 1/2"x28	28	HC25203L05-I28UNFTM...	80294	1/4	.203	2.244	.518	3	14	.216
		7/16"; 1/2"x28	28	HC37371L08-I28UNEFTM...	80295	3/8	.371	2.874	.875	3	24	.401
No.10-24	5/16"; 3/8"x24	9/16"-11/16"x24	24	HC19141L04-I24UNCTM...	80296	3/16	.141	1.772	.396	3	9	.150
No.12-24	5/16"; 3/8"x24	9/16"-11/16"x24	24	HC25163L04-I24UNCTM...	80297	1/4	.163	2.244	.437	3	10	.177
	5/16"; 3/8"x24	9/16"-11/16"x24	24	HC31263L06-I24UNFTM...	80298	5/16	.263	2.402	.646	3	15	.272
	3/8"x24	9/16"-11/16"x24	24	HC37323L07-I24UNFTM...	80299	3/8	.323	2.874	.771	3	18	.335
		9/16"-11/16"x24	24	HC50496L11-I24UNEFTM...	80300	1/2	.496	3.150	1.145	4	27	.520
1/4"x20	7/16"; 1/2"x20	3/4"-1"x20	20	HC25192L05-I20UNCTM...	80301	1/4	.192	2.244	.525	3	10	.201
	7/16"; 1/2"x20	3/4"-1"x20	20	HC37362L08-I20UNFTM...	80302	3/8	.362	2.874	.875	3	17	.390
	1/2"x20	3/4"-1"x20	20	HC50437L10-I20UNFTM...	80303	1/2	.437	3.150	1.025	4	20	.453
		3/4"-1"x20	20	HC75685L15-I20UNEFTM...	80304	3/4	.685	4.016	1.525	4	30	.701
5/16"x18	9/16"; 5/8"x18	11/16"-1 11/16"x18	18	HC31242L06-I18UNCTM...	80305	5/16	.242	2.402	.639	3	11	.260
	9/16"; 5/8"x18	11/16"-1 11/16"x18	18	HC50492L11-I18UNFTM...	80306	1/2	.492	3.150	1.139	4	20	.512
	5/8"x18	11/16"-1 11/16"x18	18	HC63555L12-I18UNFTM...	80307	5/8	.555	3.622	1.250	4	22	.575
3/8"x16	3/4"x16		16	HC31301L07-I16UNCTM...	80308	5/16	.301	2.402	.781	3	12	.315
	3/4"x16		16	HC75669L15-I16UNFTM...	80309	3/4	.669	4.016	1.528	4	24	.689
7/16"x14	7/8"x14		14	HC37354L08-I14UNCTM...	80310	3/8	.354	2.874	.893	3	12	.370
	7/8"x14		14	HC75746L17-I14UNFTM...	80311	3/4	.746	4.016	1.750	4	24	.807
1/2"x13			13	HC50407L10-I13UNCTM...	80312	1/2	.407	3.150	1.039	4	13	.430
9/16"x12	1"-1 1/2"x12		12	HC50465L11-I12UNCTM...	80313	1/2	.465	3.150	1.125	4	13	.484
	1"-1 1/2"x12		12	HC75746L20-I12UNFTM...	80314	3/4	.746	4.016	2.042	4	24	.925
5/8"x11			11	HC63516L13-I11UNCTM...	80315	5/8	.516	3.622	1.318	4	14	.539
3/4"x10			10	HC63622L15-I10UNCTM...	80316	5/8	.622	3.622	1.550	4	15	.657
7/8"x9			9	HC75746L18-I9UNCTM...	80317	3/4	.746	4.016	1.833	4	16	.768
1"x8			8	HC75746L20-I8UNCTM...	80318	3/4	.746	4.016	2.063	4	16	.866

* Bore diameter applies to smallest thread dia.

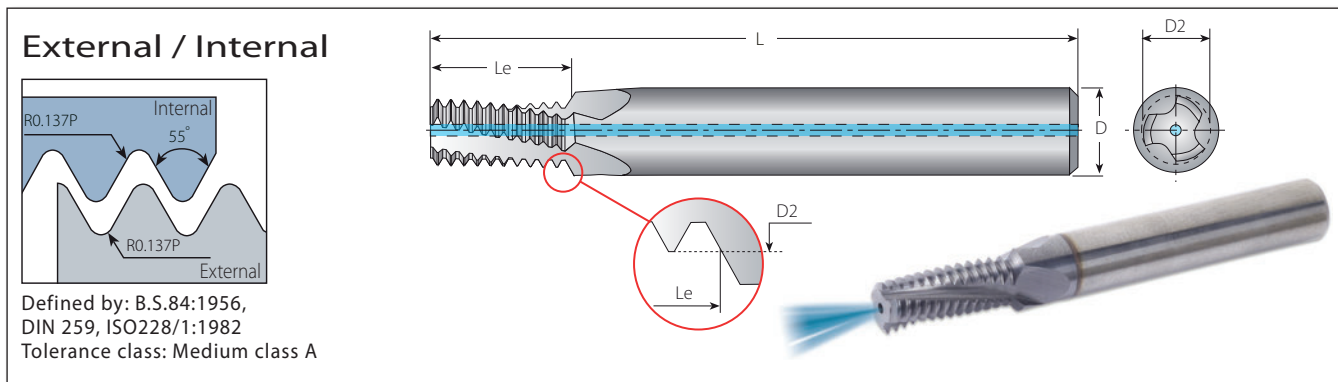

Defined by: B.S.84:1956,
DIN 259, ISO228/1:1982
Tolerance class: Medium class A

Helical Flutes with Thru-Hole Coolant

2 x Do (Le ≤ 2 x Thread Diameter)

Thread		Pitch	Ordering Code	EDP No.	Dimensions Inch				No. of Flutes	Teeth	Bore Dia.*
BSW	BSF	TPI	External / Internal	VTH	D	D2	L	Le	Z	Zt	Inch
	1/4"x26	26	HC25197L05-EI26BSFTM...	80368	1/4	.197	2.244	.519	3	13	.209
	5/16"x22	22	HC31250L06-EI22BSFTM...	80369	5/16	.250	2.402	.659	3	14	.264
1/4"x20	3/8"x20	20	HC25175L05-EI20BSWTM...	80370	1/4	.175	2.244	.525	3	10	.197
	3/8"x20	20	HC31301L07-EI20BSFTM...	80371	5/16	.301	2.402	.775	3	15	.323
5/16"x18	7/16"x18	18	HC25230L06-EI18BSWTM...	80372	1/4	.230	2.244	.639	3	11	.256
	7/16"x18	18	HC37362L09-EI18BSFTM...	80373	3/8	.362	2.874	.917	3	16	.382
3/8"x16	1/2", 9/16"x16	16	HC31283L07-EI16BSWTM...	80374	5/16	.283	2.402	.781	3	12	.311
	1/2", 9/16"x16	16	HC50413L10-EI16BSFTM...	80375	1/2	.413	2.874	1.031	4	16	.437
	9/16"x16	16	HC50478L11-EI16BSFTM...	80376	1/2	.478	3.150	1.156	4	18	.496
7/16"x14	5/8", 11/16"x14	14	HC37335L08-EI14BSWTM...	80377	3/8	.335	2.874	.893	3	12	.362
	5/8", 11/16"x14	14	HC63528L12-EI14BSFTM...	80378	5/8	.528	3.150	1.250	4	17	.551
	11/16"x14	14	HC63591L13-EI14BSFTM...	80379	5/8	.591	3.622	1.393	4	19	.614
1/2"x12	3/4"x12	12	HC37362L10-EI12BSWTM...	80380	3/8	.362	2.874	1.042	3	12	.413
9/16"x12	3/4"x12	12	HC50444L11-EI12BSWTM...	80381	1/2	.444	3.150	1.125	4	13	.476
	3/4"x12	12	HC63622L15-EI12BSFTM...	80382	5/8	.622	3.622	1.542	4	18	.661
5/8"x11	7/8"x11	11	HC50496L13-EI11BSWTM...	80383	1/2	.496	3.150	1.318	4	14	.528
	11/16"x11	11	HC63559L14-EI11BSWTM...	80384	5/8	.559	3.622	1.409	4	15	.591

* Bore diameter applies to smallest thread dia.

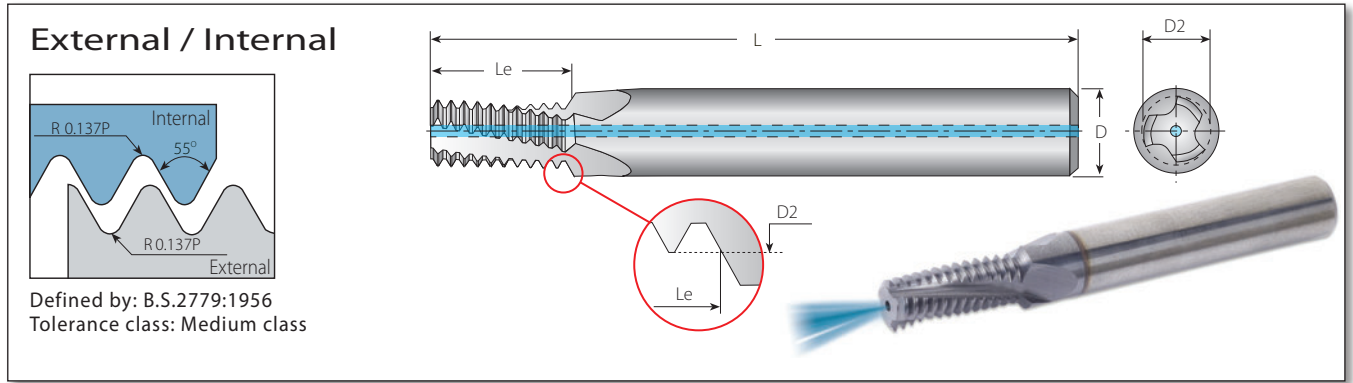

Helical Flutes with Thru-Hole Coolant

1.5 x Do (Le ≤ 1.5 x Thread Diameter)

Thread	Pitch	Ordering Code	EDP No.	Dimensions Inch				No. of Flutes	Teeth	Bore Dia.*
Standard	TPI	External / Internal	VTH	D	D2	L	Le	Z	Zt	Inch
1/16", 1/8"x28	28	HC31252L04-EI28BSPTM...	80386	5/16	.252	2.402	.480	3	13	.264
1/8"x28	28	HC37323L05-EI28BSPTM...	80388	3/8	.323	2.874	.591	3	16	.324
1/4", 3/8"x19	19	HC50433L08-EI19BSPTM...	80389	1/2	.433	2.874	.815	4	15	.465
3/8"x19	19	HC63571L10-EI19BSPTM...	80391	5/8	.571	3.622	1.028	4	19	.602
1"-4"x11	11	HC75746L16-EI11BSPTM...	80393	3/4	.746	4.016	1.681	4	18	1.208

Helical Flutes with Thru-Hole Coolant

2 x Do (Le ≤ 2 x Thread Diameter)

Thread	Pitch	Ordering Code	EDP No.	Dimensions Inch				No. of Flutes	Teeth	Bore Dia.*
Standard	TPI	External / Internal	VTH	D	D2	L	Le	Z	Zt	Inch
1/16", 1/8"x28	28	HC31252L06-EI28BSPTM...	80385	5/16	.252	2.402	.625	3	17	.264
1/8"x28	28	HC37323L07-EI28BSPTM...	80387	3/8	.323	2.874	.768	3	21	.324
1/4", 3/8"x19	19	HC50433L10-EI19BSPTM...	80319	1/2	.433	3.150	1.079	4	20	.465
3/8"x19	19	HC63571L13-EI19BSPTM...	80390	5/8	.571	3.622	1.342	4	25	.602
1/2"-7/8"x14	14	HC75705L16-EI14BSPTM...	80392	3/4	.705	4.016	1.678	4	23	.752

* Bore diameter applies to smallest thread dia.

NPT

Helicool

External / Internal

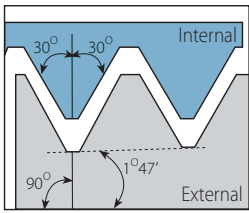

Defined by: USAS B2.1:1968
Tolerance class: Standard NPT

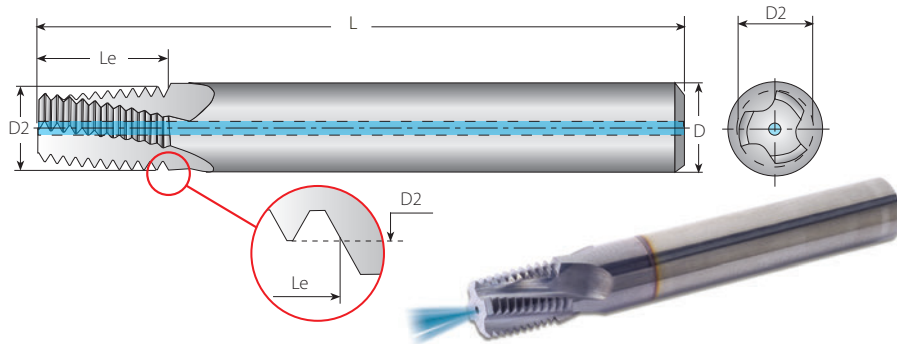

Helical Flutes with Thru-Hole Coolant

Thread	Pitch	Ordering Code	EDP No.	Dimensions Inch				No. of Flutes	Teeth	Bore Dia.*
Standard	TPI	External / Internal	VTH	D	D2	L	Le	Z	Zt	Inch
1/16"x27	27	HC25232L03-EI27NPT-TM...	80321	1/4	.232	2.244	.389	3	10	.244
1/8"x27	27	HC31301L03-EI27NPT-TM...	80322	5/16	.301	2.402	.389	3	10	.330
1/4"x18	18	HC37370L05-EI18NPT-TM...	80323	3/8	.370	2.874	.583	3	10	.437
3/8"x18	18	HC50439L05-EI18NPT-TM...	80324	1/2	.439	2.874	.583	4	10	.562
1/2", 3/4"x14	14	HC63561L07-EI14NPT-TM...	80325	5/8	.561	3.150	.750	4	10	.704, .905
1", 1 1/4", 1 1/2", 2"x11.5	11.5	HC75746L09-EI11.5NPT-TM...	80326	3/4	.746	4.016	.913	4	10	1.411, 1.484, 1.732, 2.204
2 1/2", 3"x8	8	HC75746L13-EI8NPT-TM...	80327	3/4	.746	4.016	1.313	4	10	2.625, 3.232

ANPT

Helicool

External / Internal

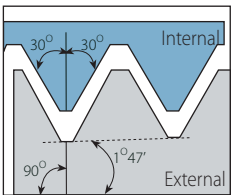

Defined by: MIL-P-7105B
Tolerance class: Standard ANPT

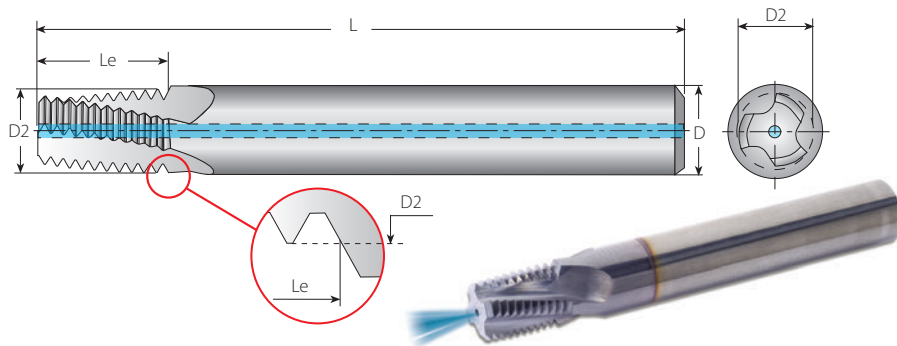

Helical Flutes with Thru-Hole Coolant

Thread	Pitch	Ordering Code	EDP No.	Dimensions Inch				No. of Flutes	Teeth	Bore Dia.*
Standard	TPI	External / Internal	VTH	D	D2	L	Le	Z	Zt	Inch
1/4"x18	18	HC37370L05-EI18ANPT-TM...	81054	3/8	.370	2.874	.583	3	10	.437
1/2", 3/4"x14	14	HC63561L07-EI14ANPT-TM...	81055	5/8	.561	3.150	.750	4	10	.704, .905

* Bore diameter applies to smallest thread dia.

NPTF

Helicool

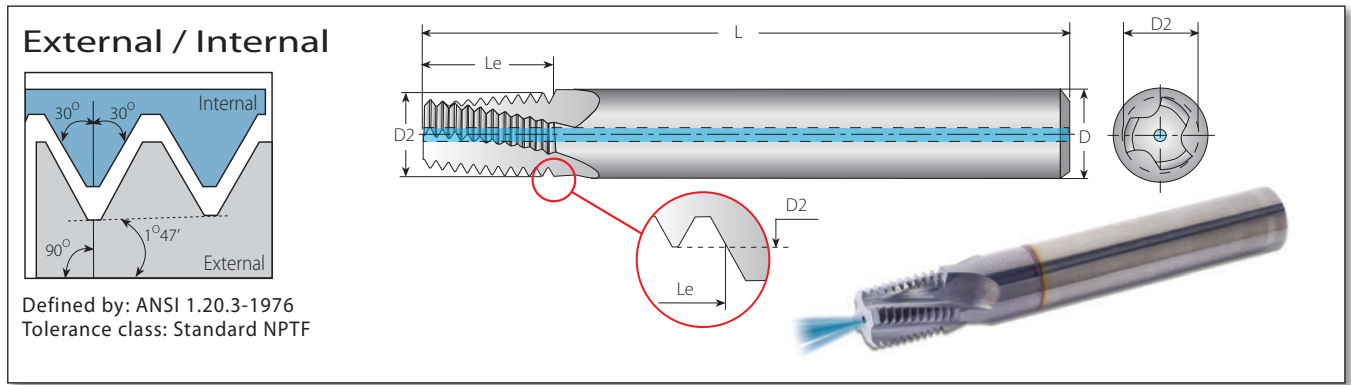

Helical Flutes with Thru-Hole Coolant

Thread	Pitch	Ordering Code	EDP No.	Dimensions Inch				No. of Flutes	Teeth	Bore Dia.*
Standard	TPI	External / Internal	VTH	D	D2	L	Le	Z	Zt	Inch
1/16"x27	27	HC25232L03-EI27NPTFTM...	80328	1/4	.232	2.244	.389	3	10	.240
1/8"x27	27	HC31301L03-EI27NPTFTM...	80329	5/16	.301	2.402	.389	3	10	.330
1/4"x18	18	HC37370L05-EI18NPTFTM...	80330	3/8	.370	2.874	.583	3	10	.437
3/8"x18	18	HC50439L05-EI18NPTFTM...	80331	1/2	.439	2.874	.583	4	10	.562
1/2", 3/4"x14	14	HC63561L07-EI14NPTFTM...	80332	5/8	.561	3.150	.750	4	10	.704, .905
1", 1 1/4", 1 1/2", 2"x11.5	11.5	HC75746L09-EI11.5NPTFTM...	80333	3/4	.746	4.016	.913	4	10	1.411, 1.484, 1.720, 2.188
2 1/2"x8; 3"x8	8	HC75746L13-EI8NPTFTM...	80334	3/4	.746	4.016	1.313	4	10	2.610, 3.232

BSPT

Helicool

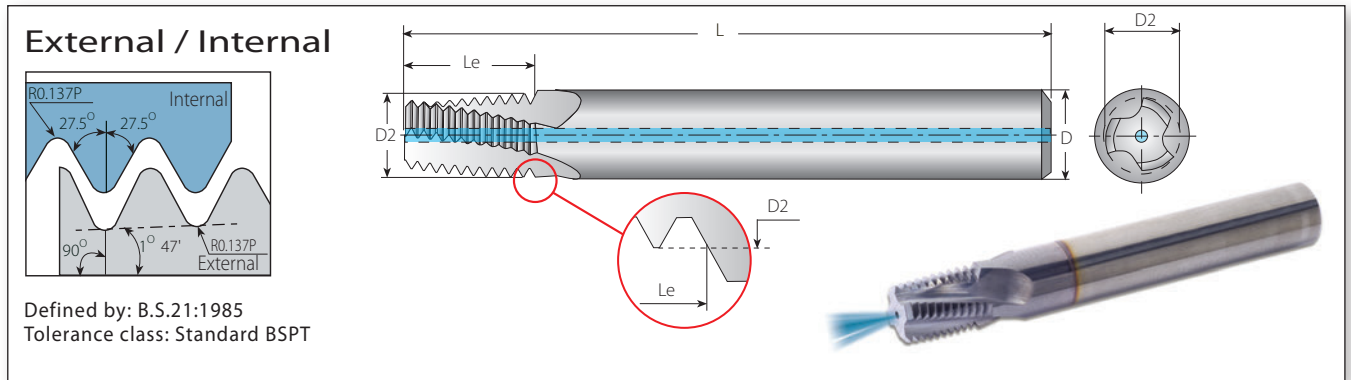

Helical Flutes with Thru-Hole Coolant

Thread	Pitch	Ordering Code	EDP No.	Dimensions Inch				No. of Flutes	Teeth	Bore Dia.*
Standard	TPI	External / Internal	VTH	D	D2	L	Le	Z	Zt	Inch
1/16"x28	28	HC25232L03-EI28BSPT-TM...	80394	1/4	.232	2.402	.401	3	11	.264
1/8"x28	28	HC31301L03-EI28BSPT-TM...	80320	5/16	.301	2.402	.401	3	11	.342
1/4"x19	19	HC50400L05-EI19BSPT-TM...	80395	1/2	.400	2.874	.605	3	11	.464
3/8"x19	19	HC50439L05-EI19BSPT-TM...	80396	1/2	.439	2.874	.605	4	11	.598
1/2, 3/4"x14	14	HC63561L08-EI14BSPT-TM...	80397	5/8	.561	3.150	.893	4	12	.748
1", 1 1/2", 2", 2 1/2"x11	11	HC75746L10-EI11BSPT-TM...	80398	3/4	.746	4.016	1.136	4	12	1.209

* Bore diameter applies to smallest thread dia.

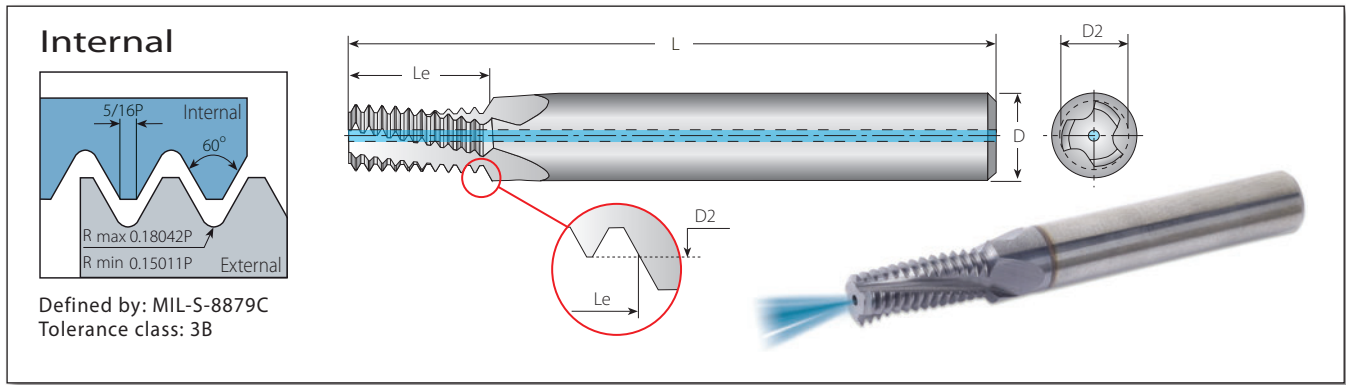

Helical Flutes with Thru-Hole Coolant

2 x Do (Le ≤ 2 x Thread Diameter)

Thread		Pitch	Ordering Code	EDP No.	Dimensions Inch			No. of Flutes	Teeth	Bore Dia.*			
UNJC	UNJF	UNJEF	UNJ	TPI	Internal	VTH	D	D2	L	Le	Z	Zt	mm
0.138" (#6)	0.190" (#10)	0.216" (#12)	0.4375" (7/16")	32	HC19106L02-I32UNJTM...	80106	3/16	.106	1.772	.297	3	9	.110
-	0.250" (1/4")	0.4375" (7/16")	0.5625" (9/16")	28	HC25213L05-I28UNJTM...	81110	1/4	.213	2.244	.518	3	14	.220
0.190" (#10)	0.3125" (5/16")	0.5625" (9/16")	-	24	HC19146L03-I24UNJTM...	80108	3/16	.146	1.772	.396	3	9	.157
-	0.3125" (5/16")	0.5625" (9/16")	-	24	HC31264L06-I24UNJTM...	80109	5/16	.264	2.402	.646	3	15	.276
0.250" (1/4")	0.4375" (7/16")	0.750" (3/4")	0.3125" (5/16")	20	HC25197L05-I20UNJTM...	80110	1/4	.197	2.244	.525	3	10	.209
-	0.4375" (7/16")	0.750" (3/4")	0.5625" (9/16")	20	HC37371L08-I20UNJTM...	80111	3/8	.371	2.874	.875	4	17	.394
0.3125" (5/16")	0.5625" (9/16")	1.0625" (1 1/16")	-	18	HC31252L06-I18UNJTM...	80112	5/16	.252	2.402	.639	3	11	.266
0.375" (3/8")	0.750" (3/4")	-	0.4375" (7/16")	16	HC31303L07-I16UNJTM...	80113	5/16	.303	2.402	.781	3	12	.319
0.4375" (7/16")	0.875" (7/8")	-	-	14	HC37362L08-I14UNJTM...	80114	3/8	.362	2.874	.893	4	12	.374
0.500" (1/2")	-	-	-	13	HC37371L10-I13UNJTM...	80115	3/8	.371	2.874	1.039	4	13	.433

* Bore diameter applies to smallest thread dia.

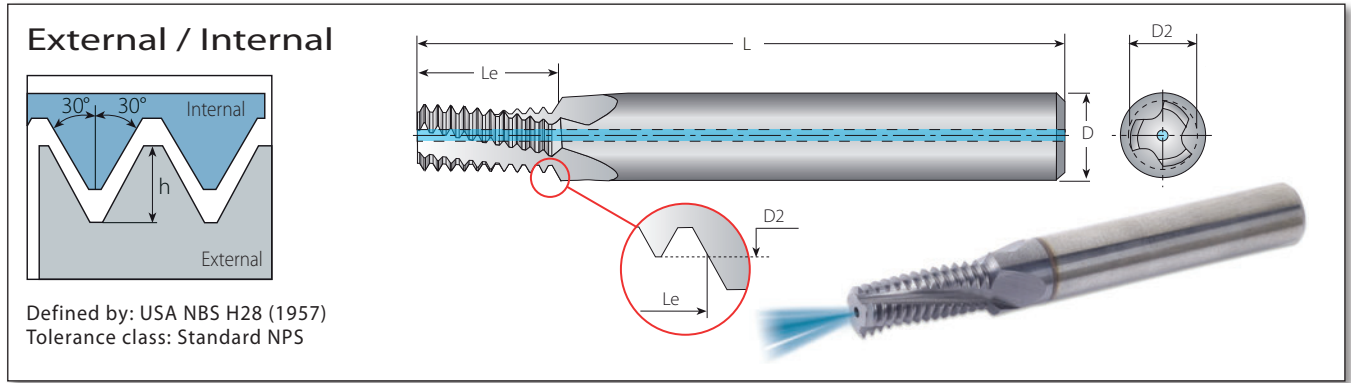

Helical Flutes with Thru-Hole Coolant

Thread	Pitch	Ordering Code	EDP No.	Dimensions Inch				No. of Flutes	Teeth	Bore Dia.*
Standard	TPI	External / Internal	VTH	D	D2	L	Le	Z	Zt	Inch
1/8"	27	HC31301L03-EI27NPSTM...	80116	5/16	.301	2.402	.389	3	10	.330
1/4"	18	HC37370L05-EI18NPSTM...	80117	3/8	.370	2.874	.583	3	10	.437
3/8"	18	HC50439L05-EI18NPSTM...	80118	1/2	.439	2.874	.583	4	10	.562
1/2", 3/4"	14	HC63561L07-EI14NPSTM...	80119	5/8	.561	3.150	.750	4	10	.704, .905
1", 2"	11.5	HC75746L08-EI11.5NPSTM...	80120	3/4	.746	4.016	.913	4	10	1.411, 2.204

American UN

Helicool-R (HCR)

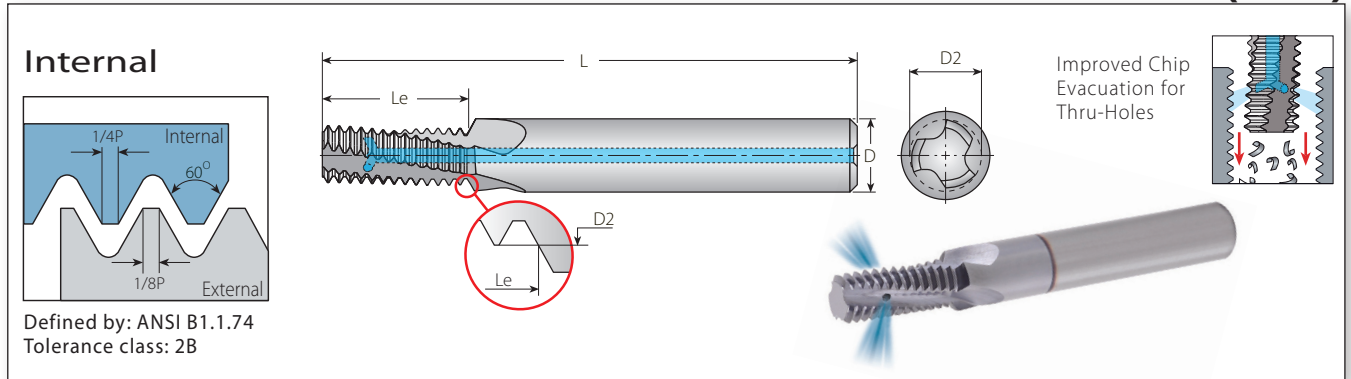

HeliCool-R (HCR)

Helical Flutes with Radial Cooling

2 x Do (Le ≤ 2 x Thread Diameter)

Thread		Pitch	Ordering Code	EDP No.	Dimensions Inch				No. of Flutes	Teeth	Bore Dia.*	
UNC	UNF	UNEF	TPI	Internal	VTH	D	D2	L	Le	Z	Zt	Inch
	No.10-32	No.12-3/8"x32	32	HCR19150L03-I32UNFTM...	80458	3/16	.150	1.772	.391	3	12	.157
	1/4"x28	7/16", 1/2"x28	28	HCR25203L05-I28UNFTM...	80459	1/4	.203	2.244	.518	3	14	.216
No.10-24	5/16", 3/8"x24	9/16"-11/16"x24	24	HCR19141L04-I24UNCTM...	80460	3/16	.141	1.772	.396	3	9	.150
No.12-24	5/16", 3/8"x24	9/16"-11/16"x24	24	HCR19163L04-I24UNCTM...	80461	3/16	.163	1.772	.437	3	10	.177
	5/16", 3/8"x24	9/16"-11/16"x24	24	HCR31263L06-I24UNFTM...	80462	5/16	.263	2.402	.646	3	15	.272
	3/8"x24	9/16"-11/16"x24	24	HCR37323L07-I24UNFTM...	80463	3/8	.323	2.874	.771	3	18	.335
1/4"x20	7/16", 1/2"x20	3/4"-1"x20	20	HCR25192L05-I20UNCTM...	80464	1/4	.192	2.244	.525	3	10	.201
	1/2"x20	3/4"-1"x20	20	HCR50437L10-I20UNFTM...	80465	1/2	.437	3.150	1.025	4	20	.453
5/16"x18	9/16", 5/8"x18	11/16"-1 1/16"x18	18	HCR31242L06-I18UNCTM...	80466	5/16	.242	2.402	.639	3	11	.260
3/8"x16	3/4"x16		16	HCR31301L07-I16UNCTM...	80467	5/16	.301	2.402	.781	3	12	.315
7/16"x14	7/8"x14		14	HCR37354L08-I14UNCTM...	80468	3/8	.354	2.874	.893	3	12	.370
1/2"x13			13	HCR50407L10-I13UNCTM...	80469	1/2	.407	3.150	1.039	4	13	.430
9/16"x12	1"-1 1/2"x12		12	HCR50465L11-I12UNCTM...	80470	1/2	.465	3.150	1.125	4	13	.484

* Bore diameter applies to smallest thread dia.

NPT

Helicoil-R (HCR)

External / Internal

Defined by: USAS B2.1:1968
Tolerance class: Standard NPT

Helicoil-R (HCR) Helical Flutes with Radial Cooling

Thread	Pitch	Ordering Code	EDP No.	Dimensions Inch				Flutes	Teeth	Bore Dia.*
Standard	TPI	Internal	VTH	D	D2	L	Le	Z	Zt	Inch
1/16"x27	27	HCR25232L03-EI27NPT-TM...	80573	1/4	.232	2.244	.389	3	10	.244
1/8"x27	27	HCR31301L03-EI27NPT-TM...	80574	5/16	.301	2.402	.389	3	10	.330
1/4"x18	18	HCR37370L05-EI18NPT-TM...	80575	3/8	.370	2.874	.583	3	10	.437
3/8"x18	18	HCR50439L05-EI18NPT-TM...	80576	1/2	.439	2.874	.583	4	10	.562
1/2", 3/4"x14	14	HCR63561L07-EI14NPT-TM...	80577	5/8	.561	3.150	.750	4	10	.704, .905
1", 1 1/4", 1 1/2", 2"x11.5	11.5	HCR75746L09-EI11.5NPT-TM...	80578	3/4	.746	4.016	.913	4	10	1.411, 1.484, 1.732, 2.204
2 1/2", 3"x8	8	HCR75746L13-EI8NPT-TM...	80579	3/4	.746	4.016	1.313	4	10	2.625, 3.232

American UN

Helicoil-C (HCC)

Internal

Defined by: ANSI B1.1:74
Tolerance class: 2B

Dc = Minimum recommended chamfer diameter

Helicoil-C (HCC) Helical Flutes with Axial Coolant - Thru & Chamfer

2 x Do (Le ≤ 2 x Thread Diameter)

Thread		Pitch	Ordering Code	EDP No.	Dimensions Inch				No. of Flutes	Teeth	Bore Dia.*			
UNC	UNF	UNEF	TPI	Internal	VTH	D	D2	Dc	L	Le	Lc	Z	Zt	inch
	No.10-32	No.12-3/8"x32	32	HCC25150L03-I32UNFTM...	80449	1/4	.150	.202	2.244	.391	.417	3	12	.157
	1/4"x28	7/16", 1/2"x28	28	HCC31203L05-I28UNFTM...	80450	5/16	.203	.262	2.402	.518	.549	3	14	.216
No.10-24	5/16", 3/8"x24	9/16"-11/16"x24	24	HCC25141L04-I24UNCTM...	80451	1/4	.141	.202	2.244	.396	.425	3	9	.150
No.12-24	5/16", 3/8"x24	9/16"-11/16"x24	24	HCC25163L04-I24UNCTM...	80452	1/4	.163	.228	2.244	.437	.468	3	10	.177
	5/16", 3/8"x24	9/16"-11/16"x24	24	HCC37263L06-I24UNFTM...	80453	3/8	.263	.324	2.874	.646	.678	3	15	.272
	3/8"x24	9/16"-11/16"x24	24	HCC50323L07-I24UNFTM...	80454	1/2	.323	.387	3.150	.771	.804	3	18	.335
1/4"x20	7/16", 1/2"x20	3/4"-1"x20	20	HCC31192L05-I20UNCTM...	80455	5/16	.192	.262	2.402	.525	.558	3	10	.201
	1/2"x20	3/4"-1"x20	20	HCC63437L10-I20UNFTM...	80456	5/8	.437	.512	3.622	1.025	1.065	3	20	.453
5/16"x18	9/16", 5/8"x18	11/16"-1 1/16"x18	18	HCC37242L16-I18UNCTM...	80457	3/8	.242	.324	2.874	.639	.676	3	11	.260
3/8"x16	3/4"x16		16	HCC50301L07-I16UNCTM...	80528	1/2	.301	.387	3.150	.781	.814	3	12	.315
7/16"x14	7/8"x14		14	HCC50354L08-I14UNCTM...	80529	1/2	.354	.449	3.150	.893	.937	3	12	.370
1/2"x13			13	HCC63407L10-I13UNCTM...	80530	5/8	.407	.512	3.622	1.039	1.087	4	13	.430
9/16"x12	1"-1 1/2"x12		12	HCC63465L11-I12UNCTM...	80531	5/8	.465	.574	3.622	1.125	1.178	4	13	.484

* Bore diameter applies to smallest thread dia.

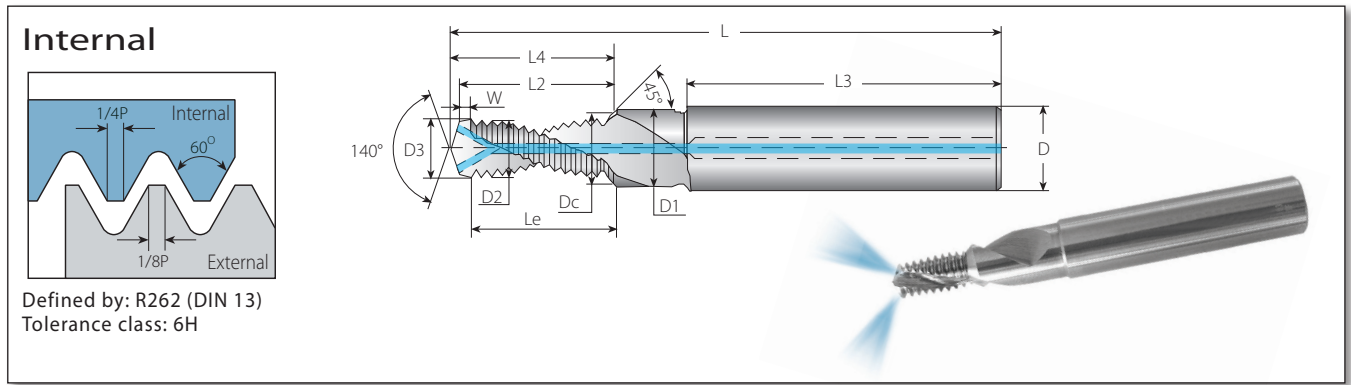

HTC (Thriller)

Drill, Chamfer & Thread with Coolant-Thru

Thread	Ordering Code	EDP No.	Pitch	Dimensions Inch										No. of Flutes	Teeth	
ISO 2xDo Coarse	Internal	VTS VTN	mm	L	L4	L2	L3	W	Le	D3	D(mm)	D1	Dc	D2	Z	Zt
M6x1.0	HTCM6x1.0x2D...	80687 80680	1.00	2.441	.571	.539	1.417	.039	.500	.197	8	.260	.248	.191	2	11
M8x1.25	HTCM8x1.25x2D...	80688 80681	1.25	2.913	.717	.673	1.575	.051	.622	.268	10	.354	.327	.254	2	11
M10x1.5	HTCM10x1.5x2D...	80689 80682	1.50	3.110	.921	.870	1.772	.059	.811	.335	12	.433	.406	.318	2	12
M12x1.75	HTCM12x1.75x2D...	80690 80683	1.75	3.504	1.067	1.004	1.772	.059	.945	.406	14	.531	.484	.383	2	12
ISO 2.5xDo Coarse																
M6x1.0	HTCM6x1.0x2.5D...	80691 80684	1.00	2.441	.650	.618	1.417	.039	.579	.197	8	.260	.248	.191	2	13
M8x1.25	HTCM8x1.25x2.5D...	80692 80685	1.25	2.913	.913	.870	1.575	.051	.819	.268	10	.354	.327	.254	2	15
M10x1.5	HTCM10x1.5x2.5D...	80693 80686	1.50	3.110	1.098	1.047	1.772	.059	.988	.335	12	.433	.406	.318	2	15

HTC - Thriller Operating Cycle

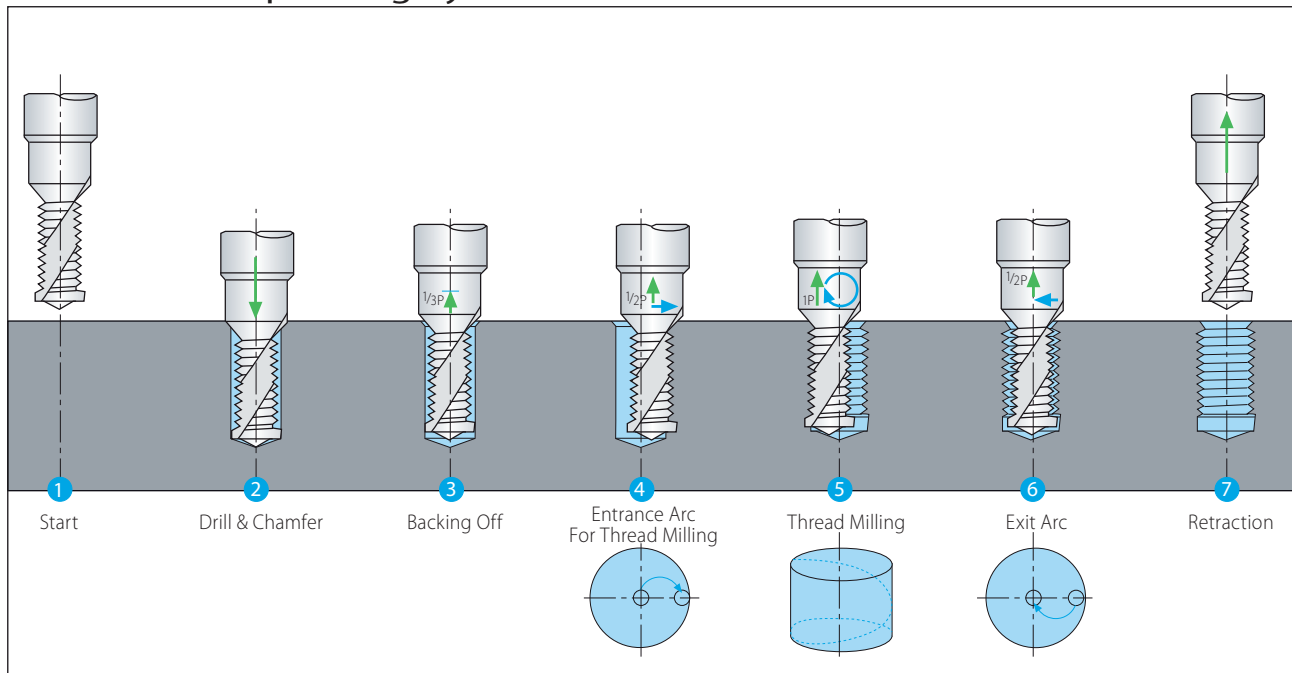

TM Solid

HTC line is suitable for Aluminium and Cast Iron machining only.

External / Internal

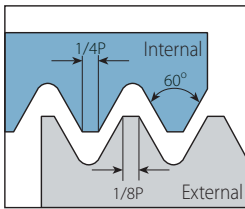

Defined by: R262 (DIN 13)
Tolerance class: 6g/6H



Helical Flutes - External (D-mm shank)

2 x Do (Le ≤ 2 x Thread Diameter)

Thread	Pitch	Ordering Code	EDP No.	Dimensions Inch			No. of Flutes	Teeth	
M Coarse	mm	External	VTH	D(mm)	D2	L	Le	Z	Zt
M3x0.5	0.5	H04039L06-E0.5ISOTM...	80891	4	.154	1.772	.236	3	12
M4.5x0.75	0.75	H04039L09-E0.75ISOTM...	80892	4	.154	1.772	.354	3	12
M6x1.0	1.0	H04039L12-E1.0ISOTM...	80893	4	.154	1.772	.472	3	12
M8x1.25	1.25	H06059L16-E1.25ISOTM...	80894	6	.232	2.244	.640	3	13
M10x1.5	1.5	H08079L21-E1.5ISOTM...	80895	8	.311	2.480	.827	3	14
M14x2.0	2.0	H10099L28-E2.0ISOTM...	80896	10	.390	2.874	1.102	4	14

Helical Flutes - Internal (D-mm shank)

2 x Do (Le ≤ 2 x Thread Diameter)

Thread	Pitch	Ordering Code	EDP No.	Dimensions Inch			No. of Flutes	Teeth	Bore Dia.*	
M Coarse	M Fine	Internal	VTH	D(mm)	D2	L	Le	Z	Zt	Inch
M3x0.5	M3.5-M16x0.5	H04022L06-I0.5ISOTM...	80897	4	.087	1.772	.236	3	12	.098
	M4x0.5	H04030L08-I0.5ISOTM...	80898	4	.118	1.772	.315	3	16	.138
	M5x0.5	H04039L10-I0.5ISOTM...	80899	4	.154	1.772	.394	3	20	.177
M4x0.7		H04028L08-I0.7ISOTM...	80900	4	.110	1.772	.331	3	12	.130
	M6x0.75	H04039L12-I0.75ISOTM...	80901	4	.154	1.772	.472	3	16	.209
M5x0.8		H04035L10-I0.8ISOTM...	80902	4	.138	1.772	.409	3	13	.165
M6x1.0	M8-M40x1.0	H04039L12-I1.0ISOTM...	80903	4	.154	1.772	.472	3	12	.197
	M8x1.0	H06059L16-I1.0ISOTM...	80904	6	.232	2.244	.630	3	16	.276
	M10x1.0	H08079L20-I1.0ISOTM...	80905	8	.311	2.480	.787	3	20	.354
	M12x1.0	H10099L24-I1.0ISOTM...	80801	10	.390	2.874	.945	4	24	.433
M8x1.25		H06058L16-I1.25ISOTM...	80907	6	.228	2.244	.640	3	13	.268
	M10x1.25	H08077L20-I1.25ISOTM...	80908	8	.303	2.480	.787	3	16	.346
M10x1.5	M12-M48x1.5	H08077L21-I1.5ISOTM...	80909	8	.303	2.480	.827	3	14	.335
	M12x1.5	H10094L24-I1.5ISOTM...	80910	10	.370	2.874	.945	4	16	.413
	M14x1.5	H12112L28-I1.5ISOTM...	80911	12	.441	3.268	1.122	4	19	.492
	M16x1.5	H12119L33-I1.5ISOTM...	80912	12	.469	3.268	1.299	4	22	.571
M12x1.75		H10087L24-I1.75ISOTM...	80913	10	.343	2.874	.965	4	14	.402
M14x2.0	M17-M80x2.0	H10099L28-I2.0ISOTM...	80914	10	.390	2.874	1.102	4	14	.472
M16x2.0	M17-M80x2.0	H12119L32-I2.0ISOTM...	80915	12	.469	3.268	1.260	4	16	.551
M18-M22x2.5		H16139L40-I2.5ISOTM...	80916	16	.547	3.622	1.575	5	16	.610
M24x3.0		H16159L42-I3.0ISOTM...	80917	16	.626	3.622	1.654	4	14	.827

* Bore diameter applies to smallest thread dia.

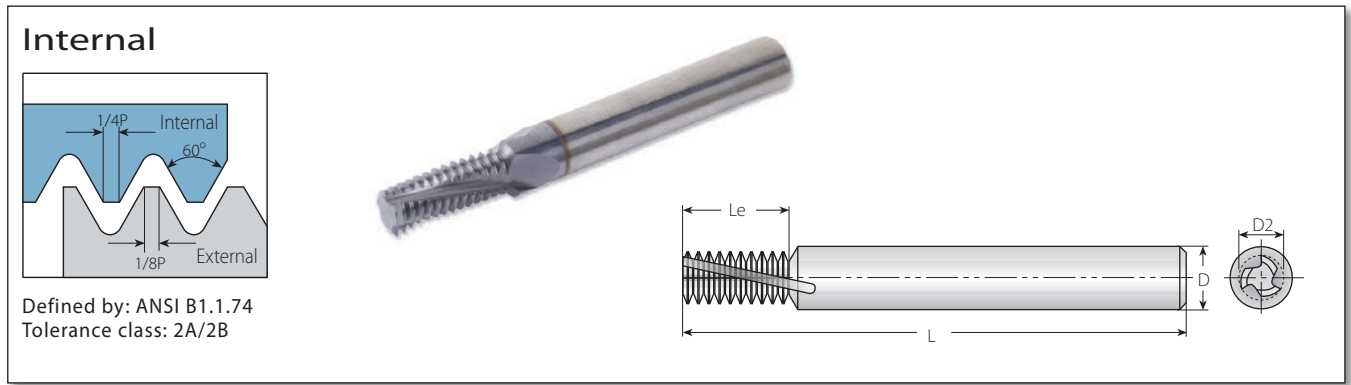

Defined by: ANSI B1.1.74
Tolerance class: 2A/2B

Helical Flutes - Internal

2 x Do (Le ≤ 2 x Thread Diameter)

Thread	Pitch	Ordering Code	EDP No.	Dimensions Inch			No. of Flutes	Teeth	Bore Dia.*		
UNC	UNF	TPI	Internal	VTH	D	D2	L	Le	Z	Zt	Inch
	No.10-32	32	HX1/8".121"-I32UNFTM...	80534	1/8	.121	2.0	.312	3	10	.157
	No.10-28	28	HX1/8".121"-I28UNFTM...	80535	1/8	.121	2.0	.321	3	9	.155
	No.12-28	28	HX3/16".150"-I28UNFTM...	80536	3/16	.150	2.5	.464	3	13	.181
	1/4"x28	28	HX3/16".181"-I28UNFTM...	80537	3/16	.181	2.5	.500	3	14	.217
No.10-24		24	HX1/8".120"-I24UNCTM...	80538	1/8	.120	2.0	.333	3	8	.150
No.12-24		24	HX3/16".138"-I24UNCTM...	80539	3/16	.138	2.5	.458	3	11	.177
	5/16"x24	24	HX1/4".232"-I24UNFTM...	80540	1/4	.232	2.5	.625	3	15	.268
	3/8"x24	24	HX5/16".291"-I24UNFTM...	80541	5/16	.291	3.0	.750	4	18	.335
1/4"x20		20	HX3/16".181"-I20UNCTM...	80542	3/16	.181	2.5	.500	3	10	.205
	1/2"x20	20	HX3/8".371"-I20UNFTM...	80543	3/8	.371	3.5	1.000	4	20	.453
	7/16"x20	20	HX3/8".335"-I20UNFTM...	80544	3/8	.335	3.5	.900	4	18	.386
5/16"x18		18	HX1/4".232"-I18UNCTM...	80545	1/4	.232	2.5	.667	3	12	.256
	9/16"x18	18	HX3/8".371"-I18UNFTM...	80546	3/8	.371	3.5	.889	4	16	.504
	5/8"x18	18	HX1/2".496"-I18UNFTM...	80547	1/2	.496	3.5	1.278	4	23	.571
3/8"x16		16	HX5/16".285"-I16UNCTM...	80548	5/16	.285	3.0	.750	4	12	.315
	3/4"x16	16	HX1/2".496"-I16UNFTM...	80549	1/2	.496	3.5	1.250	4	20	.689
7/16"x14		14	HX5/16".305"-I14UNCTM...	80550	5/16	.305	3.0	.786	4	11	.366
1/2"x13		13	HX3/8".350"-I13UNCTM...	80551	3/8	.350	3.5	.923	4	12	.425
9/16"x12		12	HX3/8".371"-I12UNCTM...	80552	3/8	.371	3.5	.917	4	11	.484
5/8"x11		11	HX1/2".469"-I11UNCTM...	80553	1/2	.469	3.5	1.273	4	14	.531
3/4"x10		10	HX1/2".496"-I10UNCTM...	80554	1/2	.496	3.5	1.300	4	13	.650
7/8"x9		9	HX5/8".621"-I9UNCTM...	80555	5/8	.621	4.0	1.444	4	13	.768
1"x8		8	HX5/8".621"-I8UNC TM...	80556	5/8	.621	4.0	1.375	4	11	.878

TM Solid

* Bore diameter applies to smallest thread dia.

External / Internal

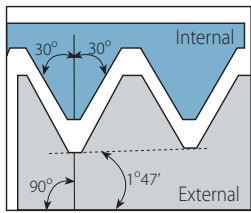

Defined by: USAS B2.1:1968
Tolerance class: Standard NPT

Helical Flutes

Thread	Pitch	Ordering Code	EDP No.	Dimensions Inch				No. of Flutes	Teeth	Bore Dia.*
Standard	TPI	External / Internal	VTH	D	D2	L	Le	Z	Zt	Inch
1/16"x27, 1/8"x27	27	HX1/4".209"-EI27NPT-TM...	80562	1/4	.209	2.5	.407	3	11	.248, .335
1/4"x18, 3/8"x18	18	HX5/16".305"-EI18NPT-TM...	80563	5/16	.305	3.0	.611	4	11	.437, .571
1/2"x14, 3/4"x14	14	HX1/2".496"-EI14NPT-TM...	80564	1/2	.496	3.5	.929	4	13	.697, .906
1"-2"x11.5	11.5	HX5/8".621"-EI11.5NPT-TM...	80565	5/8	.621	4.0	1.130	4	13	1.142-2.205
2 1/2"-6"x8	8	HX3/4".746"-EI8NPT-TM...	80566	3/4	.746	5.0	1.500	4	12	from 2.618

External / Internal

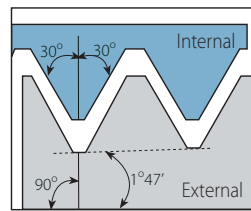

Defined by: ANSI 1.20.3-1976
Tolerance class: Standard NPTF

Helical Flutes

Thread	Pitch	Ordering Code	EDP No.	Dimensions Inch				No. of Flutes	Teeth	Bore Dia.*
Standard	TPI	External / Internal	VTH	D	D2	L	Le	Z	Zt	Inch
1/16"x27, 1/8"x27	27	HX1/4".209"-EI27NPTFTM...	80557	1/4	.209	2.5	.407	3	11	.248, .331
1/4"x18, 3/8"x18	18	HX5/16".305"-EI18NPTFTM...	80558	5/16	.305	3.0	.611	4	11	.437, .579
1/2"x14, 3/4"x14	14	HX1/2".496"-EI14NPTFTM...	80559	1/2	.496	3.5	.929	4	13	.705, .921
1"-2"x11.5	11.5	HX5/8".621"-EI11.5NPTFTM...	80560	5/8	.621	4.0	1.130	4	13	1.158-2.213
2 1/2"-6"x8	8	HX3/4".746"-EI8NPTFTM...	80561	3/4	.746	5.0	1.500	4	12	from 2.638

* Bore diameter applies to smallest thread dia.

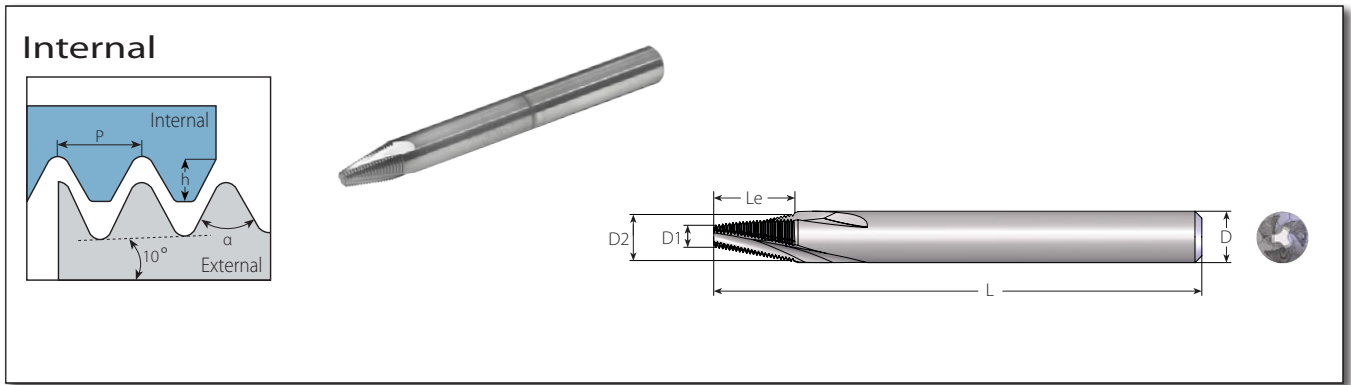

Helical Flutes - Taper 60°
TM Solid Helical Flutes for Bone Plate Applications

Pitch	Ordering Code	Taper	Thread Angle	Profile Height	Dimensions Inch				No. of Flutes	Teeth	
mm	Internal		α	h	D (mm)	D2	D1	L	Le	Z	Zt
0.4	H06059L080-10.4TAP60TM...	20°	60°	.008	6	.232	.126	2.244	.315	3	20
0.5	H06059L090-10.5TAP60TM...	20°	60°	.010	6	.232	.114	2.244	.354	3	18

Helical Flutes - Taper 55°
TM Solid Helical Flutes for Bone Plate Applications

Pitch	Ordering Code	Taper	Thread Angle	Profile Height	Dimensions Inch				No. of Flutes	Teeth	
mm	Internal		α	h	D (mm)	D2	D1	L	Le	Z	Zt
0.3	H03028L039-10.3TAP55TM...	20°	55°	.007	3	.110	.059	1.496	.154	3	13
0.35	H04039L063-10.35TAP55TM...	20°	55°	.008	4	.154	.071	1.772	.248	3	18
0.4	H06059L100-10.4TAP55TM...	20°	55°	.011	6	.232	.098	2.244	.394	3	25
0.5	H06059L090-10.5TAP55TM...	20°	55°	.013	6	.232	.114	2.244	.354	3	18
0.6	H06059L066-10.6TAP55TM...	20°	55°	.019	6	.232	.150	2.244	.260	3	11

TM Solid

American UN

Deep Threading

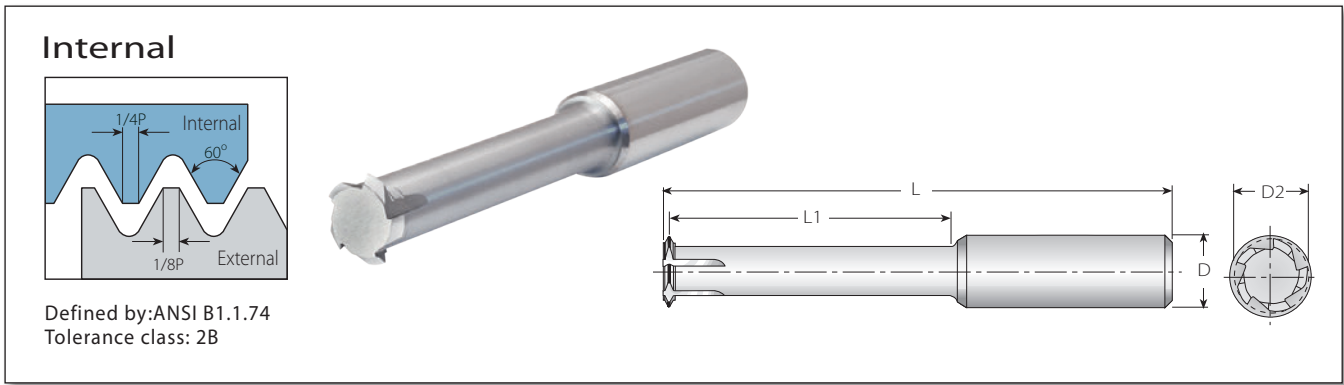

Deep Threading - Long Tools for Deep Holes

3 x Do (L1 ≤ 3 x Thread Diameter)

Thread	Pitch	Ordering Code	EDP No.	Dimensions Inch			No. of Flutes	Teeth	Bore Dia.	
UNC	UNF	Internal	VTH	D	D2	L	L1	Z	Zt	inch
1/4"x20	20	D1T5/16".157"-I20UNCTM...	80220	5/16	.157	2.480	.787	3	1	.205
	1/4"x28	D1T5/16".181"-I28UNFTM...	80271	5/16	.181	2.480	.787	3	1	.217
5/16"x18	18	D1T3/8".205"-I18UNCTM...	80221	3/8	.205	2.874	.984	3	1	.256
	5/16"x24	D1T3/8".224"-I24UNFTM...	80272	3/8	.224	2.874	.984	3	1	.268
3/8"x16	16	D1T3/8".264"-I16UNCTM...	80222	3/8	.264	2.874	1.181	3	1	.315
	3/8"x24	D1T3/8".291"-I24UNFTM...	80273	3/8	.291	2.874	1.181	3	1	.335
7/16"x14	14	D1T1/2".299"-I14UNCTM...	80274	1/2	.299	3.268	1.378	4	1	.366
	7/16"x20	D1T1/2".335"-I20UNFTM...	80275	1/2	.335	3.268	1.378	4	1	.386
1/2"x13	13	D1T1/2".350"-I13UNCTM...	80223	1/2	.350	3.268	1.575	4	1	.425
	1/2"x20	D1T1/2".398"-I20UNFTM...	80276	1/2	.398	3.268	1.575	4	1	.453
9/16"x12	12	D1T5/8".406"-I12UNCTM...	80224	5/8	.406	3.780	1.772	4	1	.484
	9/16"x18	D1T5/8".445"-I18UNFTM...	80277	5/8	.445	3.780	1.772	4	1	.504
5/8"x11	11	D1T5/8".433"-I11UNCTM...	80225	5/8	.433	3.976	1.969	4	1	.531
	5/8"x18	D1T5/8".504"-I18UNFTM...	80278	5/8	.504	3.976	1.969	4	1	.571
3/4"x10	10	D1T5/8".531"-I10UNCTM...	80226	5/8	.531	4.370	2.362	5	1	.650
	3/4"x16	D1T5/8".610"-I16UNFTM...	80227	5/8	.610	4.370	2.362	5	1	.689

American ACME (2G)

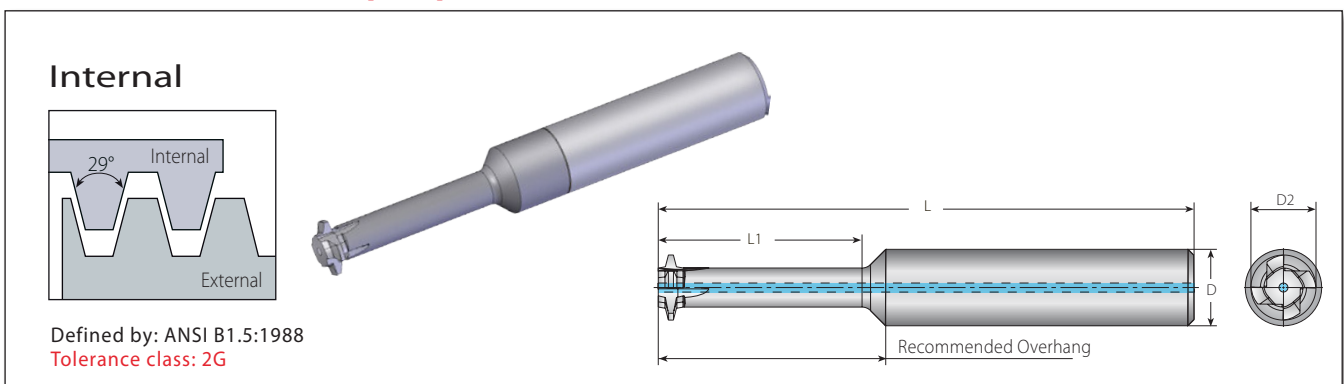

Deep Threading - Long Tools for Deep Holes

3 x Do (L1 ≤ 3 x Thread Diameter)

Thread	Pitch	Ordering Code	EDP No.	Dimensions Inch			No. of Flutes	Teeth	Bore Dia.	
UNC	TPI	Internal	VTH	D	D2	L	L1	Z	Zt	inch
3/8"-12	12	S1LC25024L075-I12ACME-2G...	81058	1/4	.240	2.520	.811	3	1	.354
1/2"-10	10	S1LC37032L100-I10ACME-2G...	81059	3/8	.327	2.990	1.071	3	1	.400
5/8"-8	8	S1LC50042L125-I8ACME-2G...	81060	1/2	.425	3.500	1.330	4	1	.500
3/4"-6	6	S1LC50049L150-I6ACME-2G...	81061	1/2	.488	3.500	1.600	5	1	.583
1"-5	5	S1LC63057L200-I5ACME-2G...	81062	5/8	.571	4.015	2.110	5	1	.800

Partial Profile 60°

Deep Threading

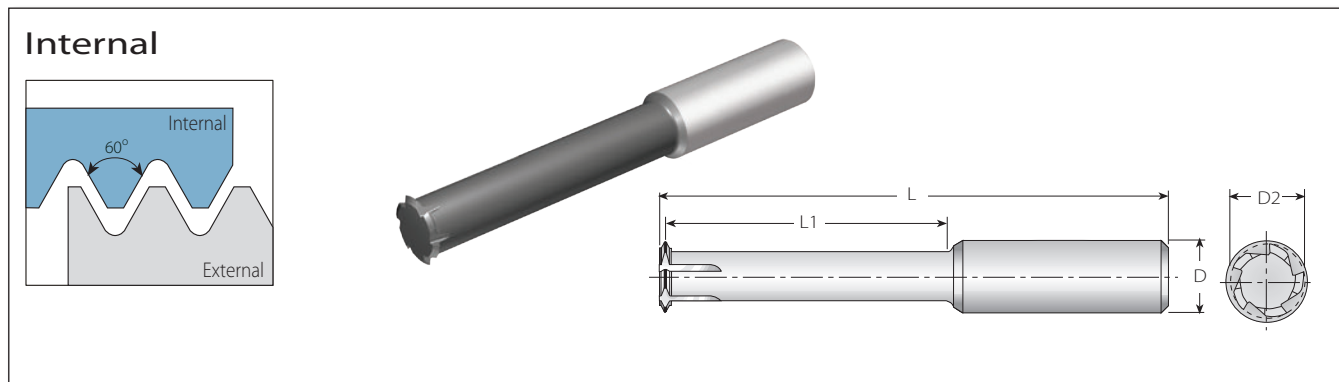

Deep Threading - Long Tools for Deep Holes

Thread		Min. Thread	Pitch		Ordering Code	EDP No.	Dimensions Inch					
M Coarse	M Fine	UN, UNS, UNF, UNEF	mm	TPI	Internal		D	D2	L	L1	Z	Zt
M5x0.8	M5x0.5, M5X0.75	No.10-56UNS, No.10-48UNS, No.10-40UNS, No.10-36UNS, No.10-32UNF	0.5-0.8	32-56	D1T19154L063-ITA60TM...	80414	3/16	.154	1.750	.63	4	1
M6x1.0	M6x0.5, M6X0.75	No.12-56UNS, No.12-48UNS, 1/4-40UNS, 1/4-36UNS, 1/4-32UNEF, 1/4-28UNF, 1/4-27UNS, 1/4-24UNS	0.5-1.0	24-56	D1T25191L079-ITB60TM...	80415	1/4	.191	2.000	.79	5	1
M8x1.25	M7x0.5, M7x0.75, M7.5x1.0	5/16-48UNS, 5/16-40UNS, 5/16-36UNS, 5/16-32UNEF, 5/16-28UN, 5/16-27UNS, 5/16-24UNS, 5/16-20UN	0.5-1.25	20-48	D1T25232L100-ITF60TM...	80416	1/4	.232	2.500	1.00	5	1
-	M10.5x0.5, M11x0.75, M11x1.0	7/16-32UN, 7/16-28UNEF, 7/16-27UNS, 7/16-24UNS	0.5-1.0	24-56	D1T37370L138-ITB60TM...	80417	3/8	.370	3.000	1.38	6	1
M10x1.5	M10x1.0, M10X1.25	3/8-24UNF, 3/8-20UN, 7/16-18UNS, 7/16-16UN	1.0-1.50	16-24	D1T31307L126-ITC60TM...	80423	5/16	.307	2.500	1.26	6	1
M12x1.75	M12x1.0, M12X1.25, M12x1.5	1/2-24UNS, 1/2-20UNS, 1/2-18UNS, 1/2-16UNS, 1/2-14UNS	1.0-1.75	14-24	D1T37370L150-ITD60TM...	80424	3/8	.370	3.000	1.50	6	1
-	M13.5x1.0, M14x1.25, M14x1.5	9/16-24UNEF	1.0-1.75	14-24	D1T50469L177-ITD60TM...	80425	1/2	.469	3.250	1.77	6	1

TM Solid

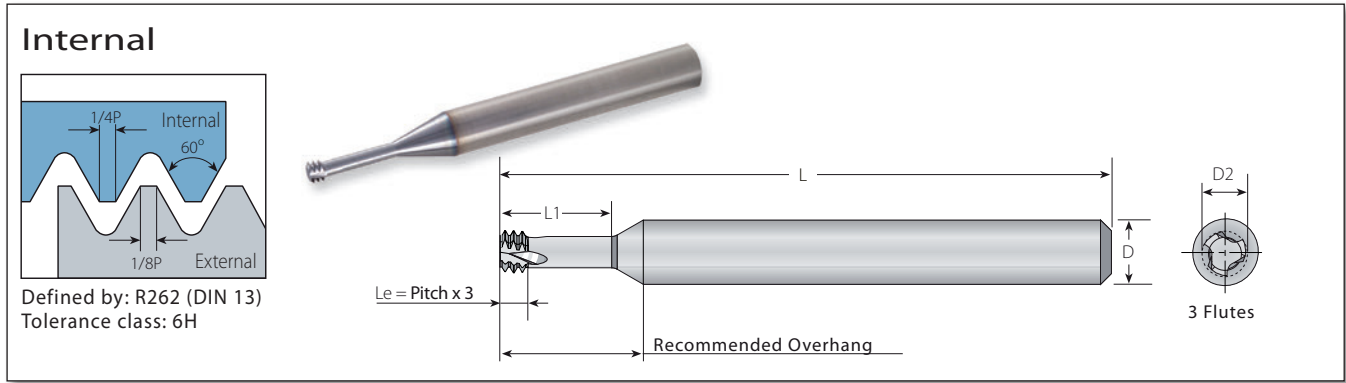

MilliPro
Miniature Thread Mills

2 x Do (L1 ≤ 2 x Thread Diameter)

Thread		Pitch	Ordering Code	EDP No.	Dimensions Inch				No. of Flutes	Teeth	Bore Dia.*
M Coarse	M Fine	mm	Internal	VTH	D	D2	L	L1	Z	Zt	mm
M1.6x0.35		0.35	D3T12047L134-I0.35ISOTM...	80660	1/8	.047	1.181	.134	3	3	.049
M2x0.4		0.4	D3T25061L165-I0.4ISOTM...	80661	1/4	.061	2.244	.165	3	3	.063
M2.2x0.45		0.45	D3T25065L181-I0.45ISOTM...	80662	1/4	.065	2.244	.181	3	3	.069
M2.5x0.45		0.45	D3T25077L205-I0.45ISOTM...	80663	1/4	.077	2.244	.205	3	3	.081
M3x0.5	M3.5-M16x0.5	0.5	D3T25094L244-I0.5ISOTM...	80664	1/4	.094	2.244	.244	3	3	.098
M3.5x0.6		0.6	D3T25108L287-I0.6ISOTM...	80665	1/4	.108	2.244	.287	3	3	.114
M4x0.7		0.7	D3T25124L327-I0.7ISOTM...	80666	1/4	.124	2.244	.327	3	3	.130
M5x0.8		0.8	D3T25159L409-I0.8ISOTM...	80667	1/4	.159	2.244	.409	3	3	.165
M6x1.0	M8-M40x1.0	1.0	D3T25189L492-I1.0ISOTM...	80668	1/4	.189	2.244	.492	3	3	.197
M8x1.25		1.25	D3T31256L654-I1.25ISOTM...	80669	5/16	.256	2.480	.654	3	3	.268
M10x1.5	M12-M48x1.50	1.50	D3T37323L819-I1.50ISOTM...	80670	3/8	.323	2.874	.819	3	3	.335
M12x1.75		1.75	D3T37371L984-I1.75ISOTM...	80671	3/8	.371	2.874	.984	3	3	.406

MilliPro
Miniature Thread Mills

3 x Do (L1 ≤ 3 x Thread Diameter)

Thread		Pitch	Ordering Code	EDP No.	Dimensions Inch				No. of Flutes	Teeth	Bore Dia.*
M Coarse	M Fine	mm	Internal	VTH	D	D2	L	L1	Z	Zt	Inch
M1.6x0.35		0.35	D3T12047L197-I0.35ISOTM...	80672	1/8	.047	1.181	.197	3	3	.049
M2x0.4		0.4	D3T25061L244-I0.4ISOTM...	80673	1/4	.061	2.244	.244	3	3	.063
M2.5x0.45		0.45	D3T25077L276-I0.45ISOTM...	80674	1/4	.077	2.244	.276	3	3	.081
M3x0.5	M3.5-M16x0.5	0.5	D3T25094L362-I0.5ISOTM...	80675	1/4	.094	2.244	.362	3	3	.098
M4x0.7		0.7	D3T25124L484-I0.7ISOTM...	80676	1/4	.124	2.244	.484	3	3	.130
M5x0.8		0.8	D3T25159L606-I0.8ISOTM...	80677	1/4	.159	2.244	.606	3	3	.165
M6x1.0	M8-M40 x1.0	1.0	D3T25189L728-I1.0ISOTM...	80678	1/4	.189	2.244	.728	3	3	.197
M8x1.25		1.25	D3T31256L969-I1.25ISOTM...	80679	5/16	.256	2.480	.969	3	3	.268

* Bore diameter applies to smallest thread dia.

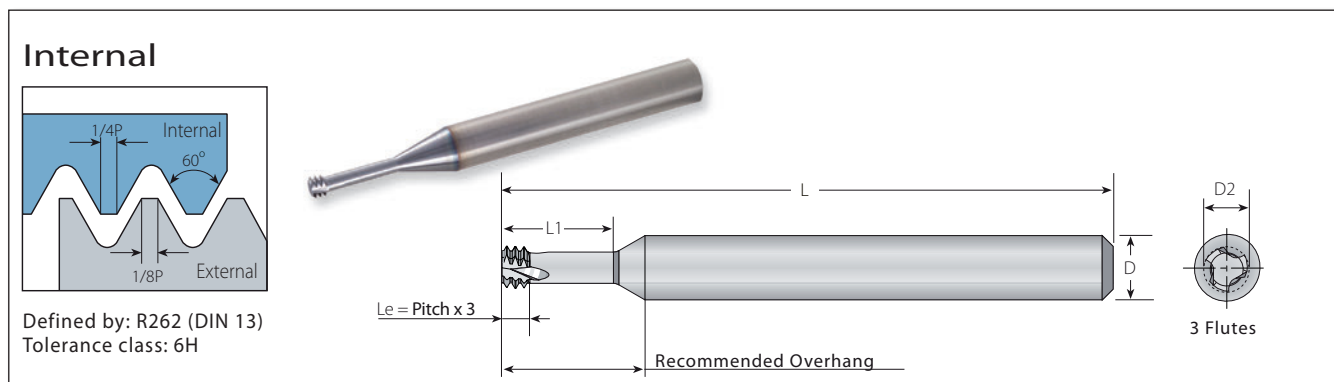

MilliPro (D-mm shank)
Miniature Thread Mills

2 x Do (L1 ≤ 2 x Thread Diameter)

Thread		Pitch	Ordering Code	EDP No.	Dimensions Inch				No. of Flutes	Teeth	Bore Dia.*
M Coarse	M Fine	mm	Internal	VTH	D(mm)	D2	L	L1	Z	Zt	Inch
M1.6x0.35		0.35	D3T03012L034-I0.35ISOTM...	80420	3	.05	1.18	.13	3	3	.05
M2x0.4		0.4	D3T06015L042-I0.4ISOTM...	80254	6	.06	2.24	.17	3	3	.06
M2.2x0.45		0.45	D3T06016L046-I0.45ISOTM...	80255	6	.06	2.24	.18	3	3	.07
M2.5x0.45		0.45	D3T06019L052-I0.45ISOTM...	80256	6	.08	2.24	.20	3	3	.08
M3x0.5	M3.5-M16x0.5	0.5	D3T06024L062-I0.5ISOTM...	80257	6	.09	2.24	.24	3	3	.10
M3.5x0.6		0.6	D3T06027L073-I0.6ISOTM...	80258	6	.11	2.24	.29	3	3	.11
M4x0.7		0.7	D3T06031L083-I0.7ISOTM...	80259	6	.12	2.24	.33	3	3	.13
M5x0.8		0.8	D3T06040L104-I0.8ISOTM...	80260	6	.16	2.24	.41	3	3	.17
M6x1.0	M8-M40x1.0	1.0	D3T06048L125-I1.0ISOTM...	80261	6	.19	2.24	.49	3	3	.20
M8x1.25		1.25	D3T08065L166-I1.25ISOTM...	80262	8	.26	2.48	.65	3	3	.27
M10x1.5	M12-M48x1.50	1.50	D3T10082L208-I1.50ISOTM...	80418	10	.32	2.87	.82	3	3	.33
M12x1.75		1.75	D3T10099L250-I1.75ISOTM...	80419	10	.39	2.87	.98	3	3	.41
M16x2.0		2.0	D3T12119L330-I2.0ISOTM...	80963	12	.47	3.27	1.30	3	3	.55
M20x2.5		2.50	D3T16159L413-I2.5ISOTM...	80962	16	.63	3.62	1.63	3	3	.69

MilliPro (D-mm shank)
Miniature Thread Mills

3 x Do (L1 ≤ 3 x Thread Diameter)

Thread		Pitch	Ordering Code	EDP No.	Dimensions Inch				No. of Flutes	Teeth	Bore Dia.*
M Coarse	M Fine	mm	Internal	VTH	D(mm)	D2	L	L1	Z	Zt	Inch
M1.6x0.35		0.35	D3T03012L050-I0.35ISOTM...	80421	3	.05	1.18	.20	3	3	.05
M2x0.4		0.4	D3T03015L062-I0.4ISOTM...	80966	3	.06	1.18	.24	3	3	.06
M2x0.4		0.4	D3T06015L062-I0.4ISOTM...	80422	6	.06	2.24	.24	3	3	.06
M2.5x0.45		0.45	D3T03019L077-I0.45ISOTM...	80964	3	.08	1.18	.30	3	3	.08
M2.5x0.45		0.45	D3T06019L077-I0.45ISOTM...	80265	6	.08	2.24	.30	3	3	.08
M3x0.5	M3.5-M16x0.5	0.5	D3T03024L092-I0.5ISOTM...	80965	3	.09	1.18	.36	3	3	.10
M3x0.5	M3.5-M16x0.5	0.5	D3T06024L092-I0.5ISOTM...	80266	6	.09	2.24	.36	3	3	.10
M4x0.7		0.7	D3T06031L123-I0.7ISOTM...	80267	6	.12	2.24	.48	3	3	.13
M5x0.8		0.8	D3T06040L154-I0.8ISOTM...	80268	6	.16	2.24	.61	3	3	.17
M6x1.0	M8-M40x1.0	1.00	D3T06048L185-I1.0ISOTM...	80269	6	.19	2.24	.73	3	3	.20
M8x1.25		1.25	D3T08065L246-I1.25ISOTM...	80270	8	.26	2.48	.97	3	3	.27

* Bore diameter applies to smallest thread dia.

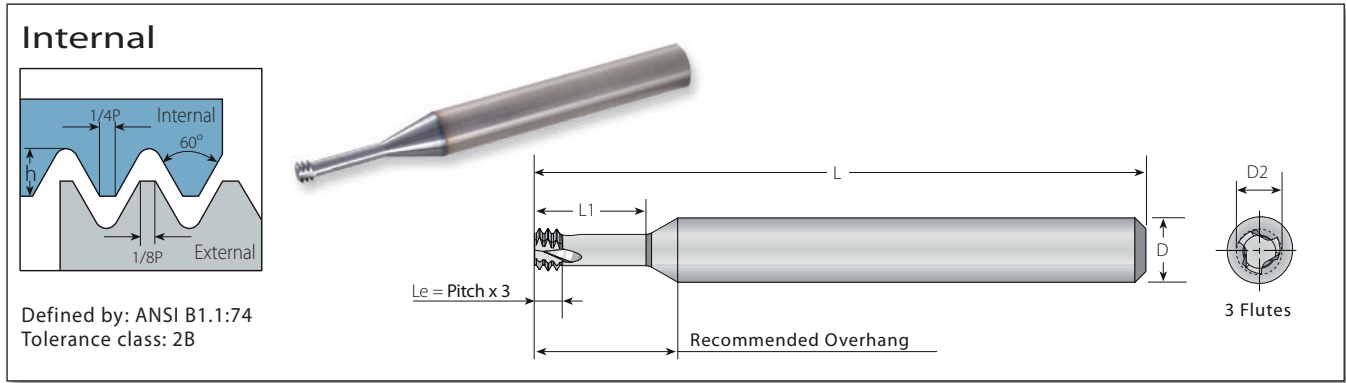

MilliPro
Miniature Thread Mills

2 x Do (L1 ≤ 2 x Thread Diameter)

Thread		Pitch	Ordering Code	EDP No.	Dimensions Inch				No. of Flutes	Teeth	Bore Dia.*
UNC	UNF	TPI	Internal	VTH	D	D2	L	L1	Z	Zt	Inch
	No.1-72	72	D3T25057L154-I72UNTM...	80215	1/4	.057	2.244	.154	3	3	.059
No.1-64	No.2-64	64	D3T25055L165-I64UNTM...	80214	1/4	.055	2.244	.165	3	3	.059
No.2-56	No.3-56	56	D3T25065L197-I56UNTM...	80216	1/4	.065	2.244	.197	3	3	.071
No.3-48	No.4-48	48	D3T25075L236-I48UNTM...	80217	1/4	.075	2.244	.236	3	3	.079
No.4, No.5-40	No.6-40	40	D3T25083L236-I40UNTM...	80218	1/4	.083	2.244	.236	3	3	.090
No.5-40	No.6-40	40	D3T25096L283-I40UNTM...	80219	1/4	.096	2.244	.283	3	3	.102
	No.8-36	36	D3T25130L343-I36UNTM...	80240	1/4	.130	2.244	.343	3	3	.138
No.6, No.8-32	No.10-32	32	D3T25100L292-I32UNTM...	80241	1/4	.100	2.244	.292	3	3	.110
No.8-32	No.10-32	32	D3T25126L394-I32UNTM...	80242	1/4	.126	2.244	.394	3	3	.134
	No.10-32	32	D3T25150L406-I32UNTM...	80694	1/4	.150	2.244	.406	3	3	.157
	1/4"x28	28	D3T25207L520-I28UNTM...	80243	1/4	.207	2.244	.520	3	3	.216
No.10-24	5/16"x24	24	D3T25141L402-I24UNTM...	80244	1/4	.141	2.244	.402	3	3	.150
	5/16"x24	24	D3T31263L650-I24UNTM...	80245	5/16	.263	2.480	.650	3	3	.272
1/4"x20	7/16"x20	20	D3T25192L528-I20UNTM...	80246	1/4	.192	2.244	.528	3	3	.201
	7/16"x20	20	D3T37375L906-I20UNTM...	80247	3/8	.375	2.874	.906	3	3	.390
5/16"x18		18	D3T31242L650-I18UNTM...	80121	5/16	.242	2.480	.650	3	3	.256
3/8"x16		16	D3T31264L752-I16UNTM...	80279	3/8	.264	2.480	.752	3	3	.315
7/16"x14		14	D3T37354L917-I14UNTM...	80248	3/8	.354	2.874	.917	3	3	.370

MilliPro
Miniature Thread Mills

3 x Do (L1 ≤ 3 x Thread Diameter)

Thread		Pitch	Ordering Code	EDP No.	Dimensions Inch				No. of Flutes	Teeth	Bore Dia.*
UNC	UNF	TPI	Internal	VTH	D	D2	L	L1	Z	Zt	mm
	No.1-72	72	D3T25057L226-I72UNTM...	80443	1/4	.057	2.244	.226	3	3	.059
No.4, No.5-40	No.6-40	40	D3T25083L354-I40UNTM...	80263	1/4	.083	2.244	.354	3	3	.091
No.5-40	No.6-40	40	D3T25096L394-I40UNTM...	80249	1/4	.096	2.244	.394	3	3	.102
No.6, No.8-32	No.10-32	32	D3T25100L433-I32UNTM...	80264	1/4	.100	2.244	.433	3	3	.110
No.8-32	No.10-32	32	D3T25126L512-I32UNTM...	80250	1/4	.126	2.244	.512	3	3	.134
	No.10-32	32	D3T25150L594-I32UNTM...	80695	1/4	.150	2.244	.594	3	3	.157
	1/4"x28	28	D3T25207L772-I28UNTM...	80251	1/4	.207	2.244	.772	3	3	.216
	5/16"x24	24	D3T31263L965-I24UNTM...	80252	5/16	.263	2.480	.965	3	3	.272
1/4"x20	7/16"x20	20	D3T25192L780-I20UNTM...	80253	1/4	.192	2.244	.780	3	3	.201
5/16"x18		18	D3T31242L944-I18UNTM...	80122	5/16	.242	2.480	.944	3	3	.256

* Bore diameter applies to smallest thread dia.

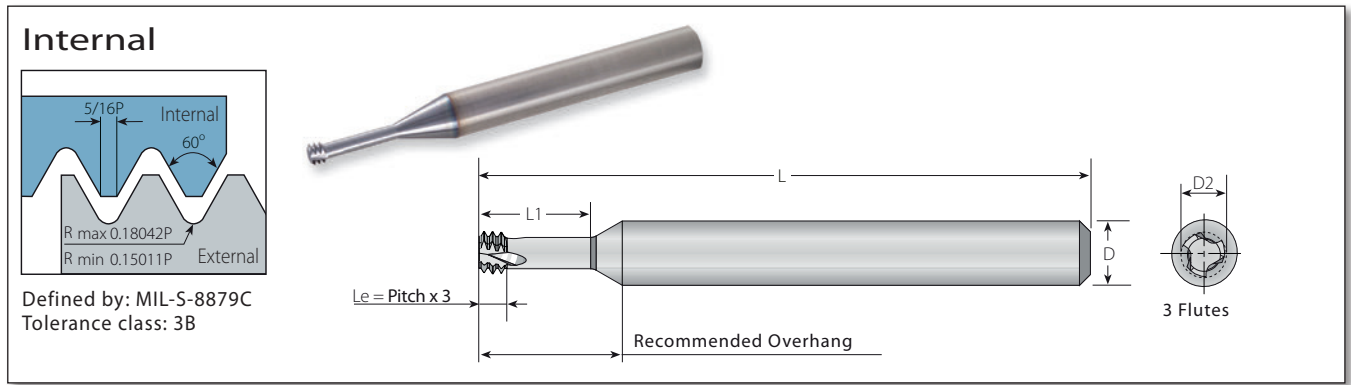

MilliPro - Miniature Thread Mills

3 x Do (L1 ≤ 3 x Thread Diameter)

Thread	Pitch	Ordering Code	EDP No.	Dimensions Inch			No. of Flutes	Teeth	Bore Dia.*		
UNJC	UNJF	TPI	Internal	VTH	D	D2	L	L1	Z	Zt	Inch
0.138" (#6)	0.190" (#10)	32	D3T25106L043-I32UNJTM...	80436	1/4	.106	2.244	.433	3	3	.110
	0.250" (1/4")	28	D3T25213L076-I28UNJTM...	80437	1/4	.213	2.244	.768	3	3	.220
0.190" (#10)	0.3125" (5/16")	24	D3T25146L058-I24UNJTM...	80438	1/4	.146	2.244	.587	3	3	.157
	0.3125" (5/16")	24	D3T31264L094-I24UNJTM...	80439	5/16	.264	2.480	.949	3	3	.276
0.250" (1/4")	0.4375" (7/16")	20	D3T25197L076-I20UNJTM...	80445	1/4	.197	2.244	.768	3	3	.209
	0.4375" (7/16")	20	D3T37371L131-I20UNJTM...	80446	3/8	.371	2.874	1.319	3	3	.394
0.3125" (5/16")	0.5625" (9/16")	18	D3T31252L094-I18UNJTM...	80961	5/16	.252	2.480	.949	3	3	.266
0.375" (3/8")	0.750" (3/4")	16	D3T31303L114-I16UNJTM...	80879	5/16	.303	2.480	1.142	3	3	.319
0.4375" (7/16")	0.875" (7/8")	14	D3T37362L131-I14UNJTM...	80880	3/8	.362	2.874	1.319	3	3	.374
0.500" (1/2")		13	D3T37371L151-I13UNJTM...	80881	3/8	.371	2.874	1.516	3	3	.433

MJ

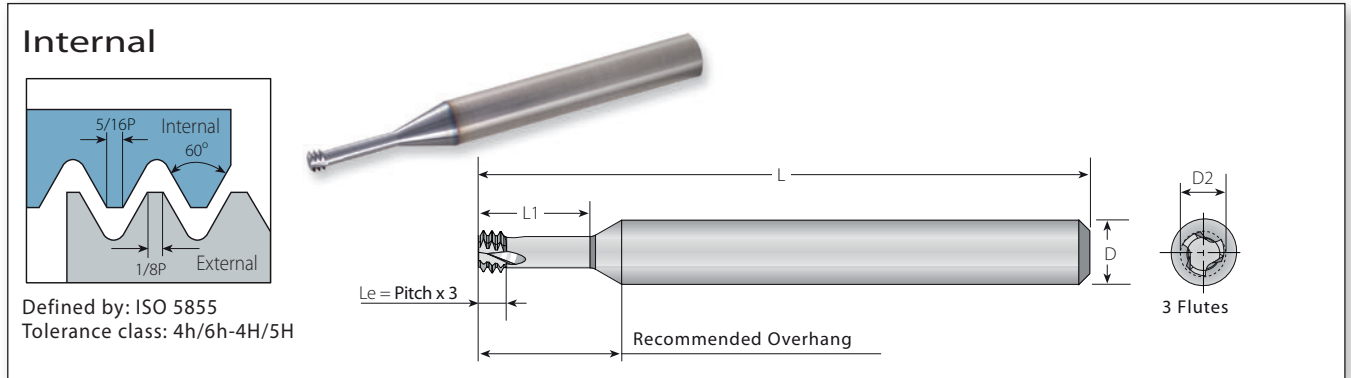

MilliPro - Miniature Thread Mills

3 x Do (L1 ≤ 3 x Thread Diameter)

Thread	Pitch	Ordering Code	EDP No.	Dimensions Inch			No. of Flutes	Teeth	Bore Dia.	
MJ	mm	Internal	VTH	D	D2	L	L1	Z	Zt	Inch
MJ3x0.5	0.5	D3T25094L036-I0.5MJTM...	80882	1/4	.094	2.244	.362	3	3	.102
MJ3.5x0.6	0.6	D3T25112L043-I0.6MJTM...	80883	1/4	.112	2.244	.433	3	3	.118
MJ4x0.7	0.7	D3T25124L048-I0.7MJTM...	80884	1/4	.124	2.244	.484	3	3	.134
MJ5x0.8	0.8	D3T25159L060-I0.8MJTM...	80885	1/4	.159	2.244	.606	3	3	.169
MJ6x1.0	1.0	D3T25189L072-I1.0MJTM...	80886	1/4	.189	2.244	.728	3	3	.201
MJ8x1.25	1.25	D3T31256L096-I1.25MJTM...	80887	5/16	.256	2.480	.969	3	3	.272
MJ10x1.5	1.50	D3T37323L121-I1.50MJTM...	80888	3/8	.323	2.874	1.213	3	3	.343
MJ12x1.75	1.75	D3T37371L145-I1.75MJTM...	80889	3/8	.371	2.874	1.457	3	3	.409
MJ14x2	2.0	D3T50469L167-I2.0MJTM...	80890	1/2	.469	3.268	1.673	3	3	.482

* Bore diameter applies to smallest thread dia.

Internal

Defined by: R262 (DIN 13)
Tolerance class: 6H

MilliPro Dental

Miniature Thread Mills for Dental Implants

3xDo (L1 ≤ 3 x Thread Diameter)

Thread		Pitch	Ordering Code	EDP No.	Dimensions Inch				No. of Flutes	Teeth	Bore Dia.
M Coarse	M Fine	mm	Internal	VTH	D(mm)	D2	L	L1	Z	Zt	Inch
M1.0x0.25	M1.4x0.25	0.25	D1T03007L031-I0.25ISOTM...	80210	3	.028	1.220	.122	3	1	.030
M1.2x0.25	M1.4x0.25	0.25	D1T03009L038-I0.25ISOTM...	80211	3	.035	1.220	.150	3	1	.037
M1.4x0.3	-	0.30	D1T03011L044-I0.30ISOTM...	80212	3	.041	1.220	.173	3	1	.045
M1.6x0.35	-	0.35	D1T03012L050-I0.35ISOTM...	80213	3	.047	1.220	.197	3	1	.051
M1.8x0.35	M2.0x0.35	0.35	D1T03014L056-I0.35ISOTM...	80280	3	.055	1.220	.220	3	1	.059
M2.0x0.4	-	0.40	D1T03015L062-I0.40ISOTM...	80281	3	.059	1.220	.244	3	1	.065
M2.5x0.45	-	0.45	D1T03019L077-I0.45ISOTM...	80282	3	.077	1.220	.303	3	1	.083

American UN

MilliPro Dental

Internal

Defined by: ANSI B1.1:74
Tolerance class: 2B

MilliPro Dental

Miniature Thread Mills for Dental Implants

3xDo (L1 ≤ 3 x Thread Diameter)

Thread		Pitch	Ordering Code	EDP No.	Dimensions Inch				No. of Flutes	Teeth	Bore Dia.
UNF	TPI		Internal	VTH	D(mm)	D2	L	L1	Z	Zt	Inch
0-80	80		D1T03011L046-I80UNTM...	80283	3	.045	1.220	.181	3	1	.051
1-72	72		D1T03014L065-I72UNTM...	80413	3	.057	1.220	.256	3	1	.063

The MilliPro Dental line was specially designed for machining Titanium and Stainless Steel in high RPM. MilliPro Dental DIT tools are also suitable for general use applications.

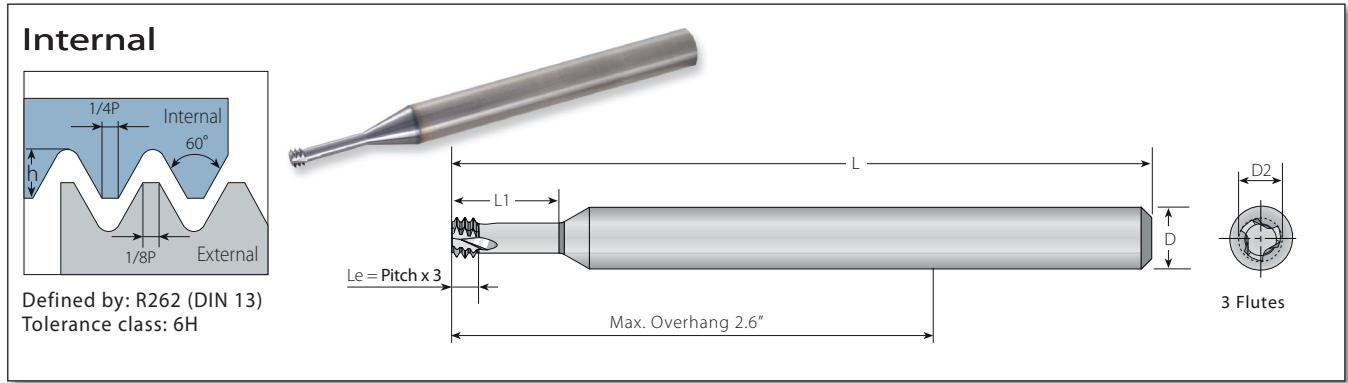

MilliPro EL
Miniature Thread Mills , Extra Long Tools

2 x Do (L1 ≤ 2 x Thread Diameter)

Thread		Pitch	Ordering Code	EDP No.	Dimensions Inch				No. of Flutes	Teeth	Bore Dia.*
M Coarse	M Fine	mm	Internal	VTH	D	D2	L	L1	Z	Zt	Inch
M2x0.4		0.4	D3T25061L165-I0.4ISOTML...	80426	1/4	.061	3.937	.165	3	3	.063
M2.5x0.45		0.45	D3T25077L205-I0.45ISOTML...	80428	1/4	.077	3.937	.205	3	3	.081
M3x0.5	M3.5-M16x0.5	0.5	D3T25094L244-I0.5ISOTML...	80429	1/4	.094	3.937	.244	3	3	.098

American UN

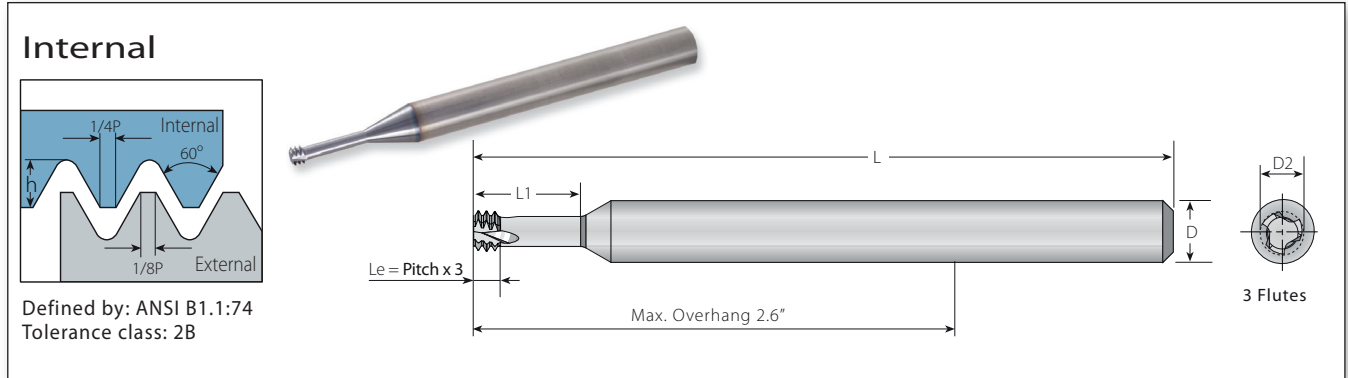

MilliPro EL
Miniature Thread Mills, Extra Long Tools

2 x Do (L1 ≤ 2 x Thread Diameter)

Thread		Pitch	Ordering Code	EDP No.	Dimensions Inch				No. of Flutes	Teeth	Bore Dia.*
UNC	UNF	TPI	Internal	VTH	D	D2	L	L1	Z	Zt	Inch
No.2-56	No.3-56	56	D3T25065L197-I56UNTML...	80430	1/4	.065	3.937	.197	3	3	.071
No.4, No.5-40	No.6-40	40	D3T25083L236-I40UNTML...	80431	1/4	.083	3.937	.236	3	3	.091
No.6, No.8-32	No.10-32	32	D3T25100L291-I32UNTML...	80432	1/4	.100	3.937	.291	3	3	.110
No.8-32	No.10-32	32	D3T25126L394-I32UNTML...	80433	1/4	.126	3.937	.394	3	3	.134

* Bore diameter applies to smallest thread dia.

TM Solid

Internal

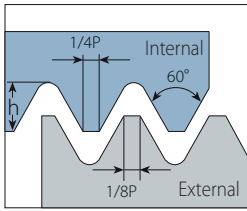

Defined by: R262 (DIN 13)
Tolerance class: 6H

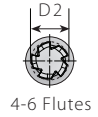
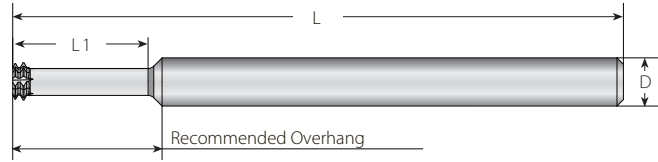

Left Hand Tool

MilliPro HD

Miniature Thread Mills for Hard Materials Up to 62HRC

2 x Do (L1 ≤ 2 x Thread Diameter)

Thread		Pitch	Ordering Code	EDP No.	Dimensions Inch				No. of Flutes	Teeth	Bore Dia.*
M Coarse	M Fine	mm	Internal	VTH	D	D2	L	L1	Z	Zt	Inch
M2x0.4		0.4	S2L25061L165-I0.4ISOTM...	80918	1/4	.061	2.99	.18	4	2	.063
M2.2x0.45		0.45	S2L25065L181-I0.45ISOTM...	80919	1/4	.065	2.99	.20	4	2	.071
M2.5x0.45		0.45	S2L25077L204-I0.45ISOTM...	80920	1/4	.077	2.99	.22	4	2	.081
M3x0.5	M3.5-M16x0.5	0.5	S2L25094L244-I0.5ISOTM...	80921	1/4	.094	2.99	.27	4	2	.101
M3.5x0.6		0.6	S2L25108L287-I0.6ISOTM...	80922	1/4	.108	2.99	.31	4	2	.116
M4x0.7		0.7	S2L25124L326-I0.7ISOTM...	80923	1/4	.124	2.99	.36	4	2	.132
M5x0.8		0.8	S2L25159L409-I0.8ISOTM...	80924	1/4	.159	2.99	.44	4	2	.169
M6x1.0	M8-M40x1.0	1.0	S2L25189L492-I1.0ISOTM...	80925	1/4	.189	2.99	.53	5	2	.201
M8x1.25		1.25	S2L31256L653-I1.25ISOTM...	80926	5/16	.256	3.15	.70	5	2	.268
M10x1.5	M12-M48x1.50	1.50	S2L31308L818-I1.50ISOTM...	80927	5/16	.308	3.15	.88	6	2	.339
M12x1.75		1.75	S2L37371L984-I1.75ISOTM...	80928	3/8	.371	3.98	1.05	6	2	.409

MilliPro HD

Miniature Thread Mills for Hard Materials Up to 62HRC

3 x Do (L1 ≤ 3 x Thread Diameter)

Thread		Pitch	Ordering Code	EDP No.	Dimensions mm				No. of Flutes	Teeth	Bore Dia.*
M Coarse	M Fine	mm	Internal	VTH	D	D2	L	L1	Z	Zt	Inch
M2x0.4		0.4	S2L25061L244-I0.4ISOTM...	80929	1/4	.061	2.99	.26	4	2	.063
M2.5x0.45		0.45	S2L25077L303-I0.45ISOTM...	80930	1/4	.077	2.99	.32	4	2	.081
M3x0.5	M3.5-M16x0.5	0.5	S2L25094L362-I0.5ISOTM...	80931	1/4	.094	2.99	.38	4	2	.101
M4x0.7		0.7	S2L25124L484-I0.7ISOTM...	80932	1/4	.124	2.99	.51	4	2	.132
M5x0.8		0.8	S2L25159L606-I0.8ISOTM...	80933	1/4	.159	2.99	.64	4	2	.169
M6x1.0	M8-M40x1.0	1.0	S2L25189L728-I1.0ISOTM...	80934	1/4	.189	2.99	.77	5	2	.201
M8x1.25		1.25	S2L31256L968-I1.25ISOTM...	80935	5/16	.256	3.15	1.02	5	2	.268

Roughing (Partial Profile)

Finish (Full Profile)

Two cutting teeth: Partial Profile for leading tooth followed by Full Profile for finishing.

The work direction should be from the top to the bottom (Climb Milling).

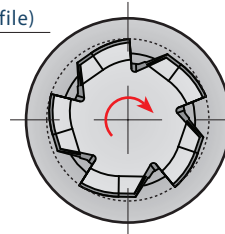
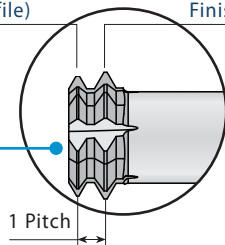

MilliPro HD Tools are left handed. For CNC use M04 code.

* Bore diameter applies to smallest thread dia.

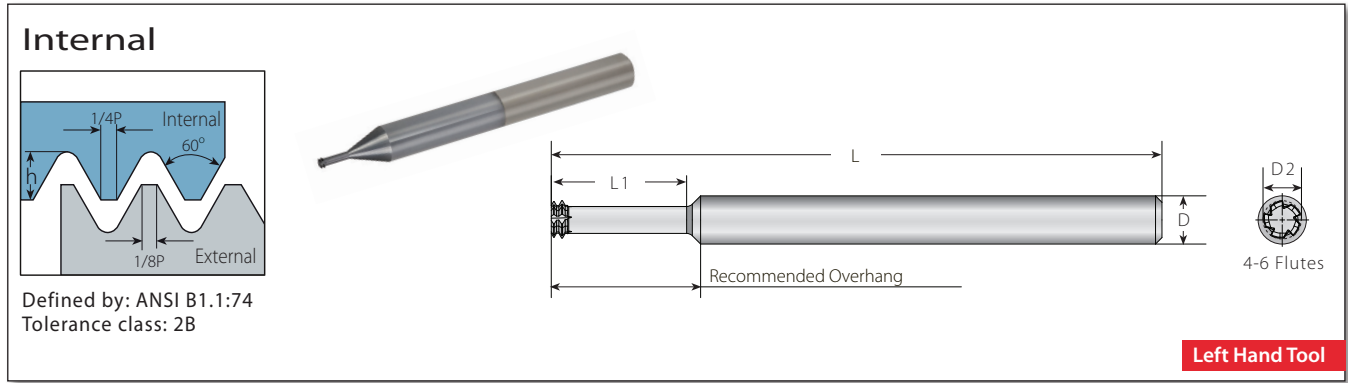

MilliPro HD

Miniature Thread Mills for Hard Materials Up to 62HRc

2 x Do (L1 ≤ 2 x Thread Diameter)

Thread		Pitch	Ordering Code	EDP No.	Dimensions Inch				No. of Flutes	Teeth	Bore Dia.*
UNC	UNF	TPI	Internal	VTH	D	D2	L	L1	Z	Zt	Inch
No.2-56	No.3-56	56	S2L25065L197-I56UNTM...	80936	1/4"	.065	3.00	.210	4	2	.071
No.3-48	No.4-48	48	S2L25075L236-I48UNTM...	80937	1/4"	.075	3.00	.260	4	2	.083
No.4-40, No.5-40	No.6-40	40	S2L25083L236-I40UNTM...	80938	1/4"	.083	3.00	.260	4	2	.093
No.5-40	No.6-40	40	S2L25096L283-I40UNTM...	80939	1/4"	.096	3.00	.310	4	2	.104
	No.8-36	36	S2L25130L343-I36UNTM...	80940	1/4"	.130	3.00	.370	4	2	.140
No.6-32, No.8-32	No.10-32	32	S2L25100L292-I32UNTM...	80941	1/4"	.100	3.00	.320	4	2	.112
No.8-32	No.10-32	32	S2L25126L394-I32UNTM...	80942	1/4"	.126	3.00	.420	4	2	.138
	No.10-32	32	S2L25146L394-I32UNTM...	80943	1/4"	.146	3.00	.430	4	2	.164
	1/4"x28	28	S2L25207L520-I28UNTM...	80944	1/4"	.207	3.00	.560	5	2	.219
No.10-24	5/16"x24	24	S2L25141L402-I24UNTM...	80945	1/4"	.141	3.00	.440	4	2	.154
	5/16"x24	24	S2L31263L650-I24UNTM...	80946	5/16"	.263	3.15	.690	5	2	.276
1/4"-20	7/16"x20	20	S2L25192L528-I20UNTM...	80947	1/4"	.192	3.00	.580	5	2	.205
	7/16"x20	20	S2L37372L906-I20UNTM...	80948	3/8"	.372	4.00	.960	6	2	.390
5/16"x18		18	S2L25242L630-I18UNTM...	80123	1/4"	.242	3.00	.715	4	2	.256
3/8"x16		16	S2L31301L776-I16UNTM...	80949	5/16"	.301	3.15	.840	5	2	.315
7/16"x14		14	S2L37354L917-I14UNTM...	80950	3/8"	.354	4.00	.990	6	2	.374
1/2"x13		13	S2L37372L101-I13UNTM...	80951	3/8"	.362	4.00	1.080	6	2	.429

MilliPro HD

Miniature Thread Mills for Hard Materials Up to 62HRc

3 x Do (L1 ≤ 3 x Thread Diameter)

Thread		Pitch	Ordering Code	EDP No.	Dimensions Inch				No. of Flutes	Teeth	Bore Dia.*
UNC	UNF	TPI	Internal	VTH	D	D2	L	L1	Z	Zt	Inch
No.4-40, No.5-40	No.6-40	40	S2L25083L354-I40UNTM...	80952	1/4"	.083	3.00	.380	4	2	.093
No.5-40	No.6-40	40	S2L25096L394-I40UNTM...	80953	1/4"	.096	3.00	.410	4	2	.104
No.6-32, No.8-32	No.10-32	32	S2L25100L433-I32UNTM...	80954	1/4"	.100	3.00	.460	4	2	.111
No.8-32	No.10-32	32	S2L25126L512-I32UNTM...	80955	1/4"	.126	3.00	.540	4	2	.136
	1/4"x28	28	S2L25207L772-I28UNTM...	80956	1/4"	.207	3.00	.810	5	2	.219
	5/16"x24	24	S2L31263L965-I24UNTM...	80957	5/16"	.263	3.15	1.010	5	2	.272
1/4"x20	7/16"x20	20	S2L25192L780-I20UNTM...	80958	1/4"	.192	3.00	.830	5	2	.204
5/16"x18		18	S2L25242L945-I18UNTM...	80124	1/4"	.242	3.00	1.030	4	2	.256
7/16"x14		14	S2L37354L131-I14UNTM...	80959	3/8"	.354	4.00	1.390	6	2	.375

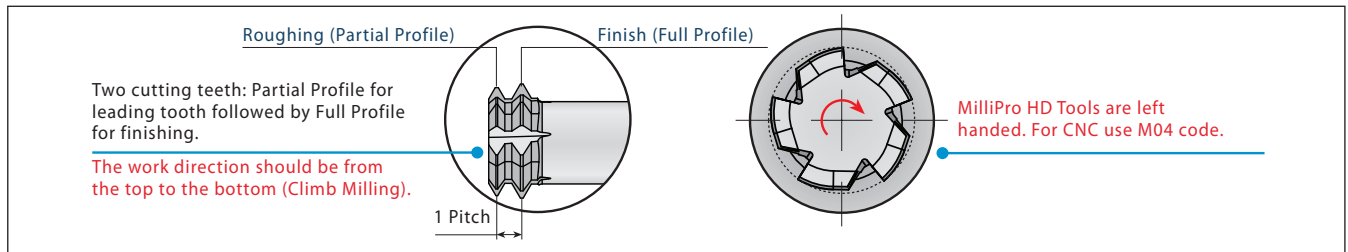

* Bore diameter applies to smallest thread dia.

Tap 60°, Tap 55°

Straight

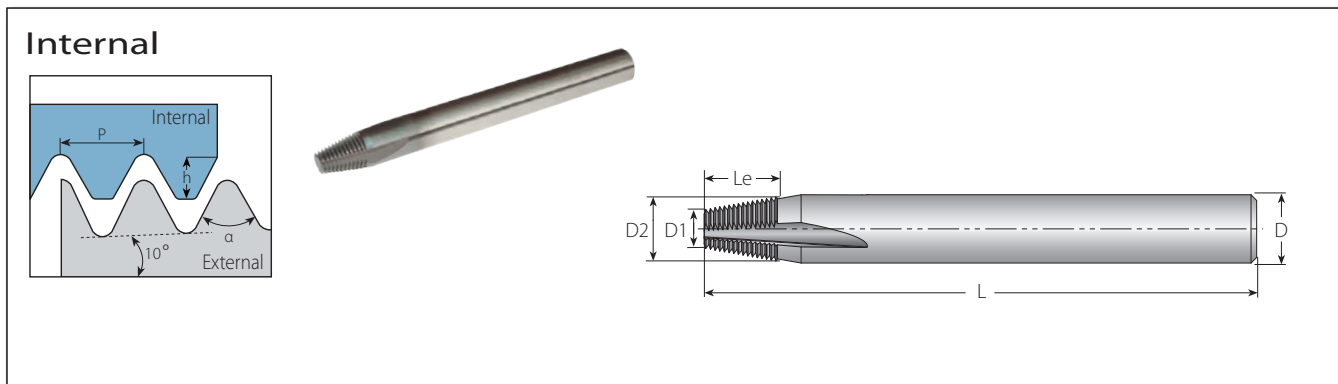

Straight Flutes - Taper 60° TM Solid Straight Flutes for Bone Plate Applications

Pitch	Ordering Code	EDP No.	Taper	Thread Angle	Profile Height	Dimensions Inch					No. of Flutes	Teeth
mm	Internal	VTS		α	h	D	D2	D1	L	Le	Z	Zt
0.4	S1/4".232"L315-I0.4TAP60TM...	80975	20°	60°	.008	1/4	.232	.126	2.244	.315	3	20
0.5	S1/4".232"L354-I0.5TAP60TM...	80976	20°	60°	.010	1/4	.232	.114	2.244	.354	3	18

Straight Flutes - Taper 55° TM Solid Straight Flutes for Bone Plate Applications

Pitch	Ordering Code	EDP No.	Taper	Thread Angle	Profile Height	Dimensions Inch					No. of Flutes	Teeth
mm	Internal	VTS		α	h	D	D2	D1	L	Le	Z	Zt
0.3	S1/8".110"L154-I0.3TAP55TM...	80977	20°	55°	.007	1/8	.110	.059	1.496	.154	3	13
0.35	S3/16".154"L248-I0.35TAP55TM...	80978	20°	55°	.008	3/16	.154	.071	1.772	.248	3	18
0.4	S1/4".232"L394-I0.4TAP55TM...	80979	20°	55°	.011	1/4	.232	.098	2.244	.394	3	25
0.5	S1/4".232"L354-I0.5TAP55TM...	80980	20°	55°	.013	1/4	.232	.114	2.244	.354	3	18
0.6	S1/4".232"L260-I0.6TAP55TM...	80981	20°	55°	.019	1/4	.232	.150	2.244	.260	3	11

External / Internal

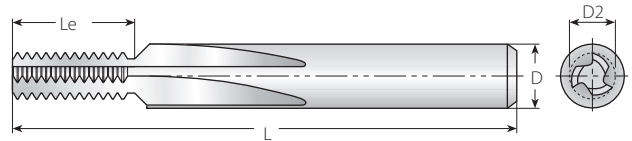
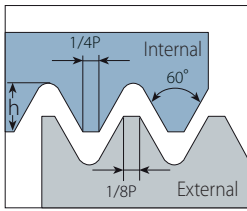

Defined by: R262 (DIN 13)
Tolerance class: 6g/6H

Straight Flutes - External

Thread	Pitch	Ordering Code	EDP No.	Dimensions Inch				No. of Flutes	Teeth	
Min. Dia.	mm	External	VTS	D	D2	L	Le	Z	Zt	h
M3	0.50	S1/4".240"-E0.5ISOTM...	80000	1/4	.240	2.244	.591	3	30	.012
M4.5	0.75	S5/16".310"-E0.75ISOTM3...	80001	5/16	.310	2.480	.610	3	26	.019
M4.5	0.75	S5/16".310"-E0.75ISOTM5...	80444	5/16	.310	2.480	.610	5	26	.019
M6	1.00	S3/8".370"-E1.0ISOTM...	80002	3/8	.370	2.835	.945	5	24	.025
M10	1.50	S1/2".470"-E1.5ISOTM...	80003	1/2	.470	3.268	1.181	5	20	.037
M14	2.00	S1/2".470"-E2.0ISOTM...	80004	1/2	.470	3.268	1.181	5	15	.050
M24	3.00	S5/8".620"-E3.0ISOTM...	80005	5/8	.620	3.622	1.417	5	12	.075
M36	4.00	S5/8".620"-E4.0ISOTM...	80006	5/8	.620	3.622	1.575	5	10	.100
M64	6.00	S3/4".745"-E6.0ISOTM...	80007	3/4	.745	4.095	1.417	5	6	.149

Straight Flutes - Internal

Thread	Pitch	Ordering Code	EDP No.	Dimensions Inch				No. of Flutes	Teeth	
Min. Dia.	mm	Internal	VTS	D	D2	L	Le	Z	Zt	h
M4.5	0.75	S1/8".120"-I0.75ISOTM...	80008	1/8	.120	1.496	.270	3	9	.017
M8	0.75	S1/4".240"-I0.75ISOTM...	80009	1/4	.240	2.244	.591	3	20	.017
M5	0.80	S3/16".145"-I0.8ISOTM...	80010	3/16	.145	1.654	.315	3	10	.018
M6	1.00	S3/16".160"-I1.0ISOTM...	80011	3/16	.160	1.654	.354	3	9	.023
M12	1.00	S5/16".310"-I1.0ISOTM3...	80012	5/16	.310	2.480	.787	3	20	.023
M12	1.00	S5/16".310"-I1.0ISOTM5...	80239	5/16	.310	2.480	.787	5	20	.023
M8	1.25	S1/4".200"-I1.25ISOTM...	80013	1/4	.200	2.244	.492	3	10	.029
M10	1.50	S1/4".240"-I1.5ISOTM...	80014	1/4	.240	2.244	.591	3	10	.035
M14	1.50	S3/8".370"-I1.5ISOTM...	80015	3/8	.370	2.835	.945	5	16	.035
M18	1.50	S1/2".470"-I1.5ISOTM...	80016	1/2	.470	3.268	1.181	5	20	.035
M12	1.75	S5/16".310"-I1.75ISOTM3...	80017	5/16	.310	2.480	.758	3	11	.040
M12	1.75	S5/16".310"-I1.75ISOTM5...	80236	5/16	.310	2.480	.758	5	11	.040
M16	2.00	S3/8".370"-I2.0ISOTM...	80018	3/8	.370	2.835	.944	5	12	.046
M18	2.00	S1/2".470"-I2.0ISOTM...	80019	1/2	.470	3.268	1.181	5	15	.046
M20	2.50	S1/2".470"-I2.5ISOTM...	80020	1/2	.470	3.268	1.181	5	12	.058
M24	3.00	S5/8".620"-I3.0ISOTM...	80021	5/8	.620	3.622	1.417	5	12	.069
M30	3.50	S5/8".620"-I3.5ISOTM...	80022	5/8	.620	3.622	1.516	5	11	.081
M36	4.00	S5/8".620"-I4.0ISOTM...	80023	5/8	.620	3.622	1.575	5	10	.092
M48	5.00	S3/4".745"-I5.0ISOTM...	80024	3/4	.745	4.095	1.575	5	8	.116
M64	6.00	S3/4".745"-I6.0ISOTM...	80025	3/4	.745	4.095	1.417	5	6	.139

External / Internal

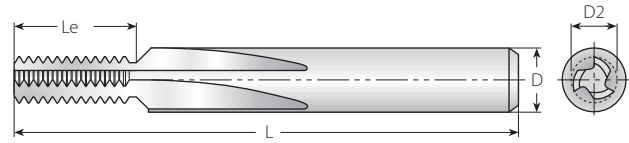
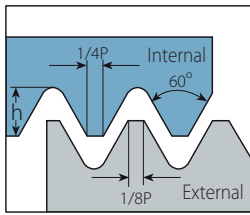

Defined by: ANSI B1.1:74
Tolerance class: 2A/2B

Straight Flutes - External

Thread	Pitch	Ordering Code	EDP No.	Dimensions Inch				No. of Flutes	Teeth	
Min. Dia.	TPI	External	VTS	D	D2	L	Le	Z	Zt	h
No.6	32	S1/4".240"-E32UNTM...	80026	1/4	.240	2.244	.562	3	18	.019
No.12	28	S5/16".310"-E28UNTM3...	80027	5/16	.310	2.480	.786	3	22	.022
No.12	28	S5/16".310"-E28UNTM5...	80408	5/16	.310	2.480	.786	5	22	.022
1/4"	20	S3/8".370"-E20UNTM...	80028	3/8	.370	2.835	.900	5	18	.031
5/16"	18	S3/8".370"-E18UNTM...	80029	3/8	.370	2.835	.944	5	17	.034
3/8"	16	S1/2".470"-E16UNTM...	80030	1/2	.470	3.268	1.125	5	18	.038
9/16"	12	S1/2".470"-E12UNTM...	80031	1/2	.470	3.268	1.167	5	14	.051
1"	8	S5/8".620"-E8UNTM...	80032	5/8	.620	3.622	1.500	5	12	.077
1 3/8"	6	S5/8".620"-E6UNTM...	80033	5/8	.620	3.622	1.500	5	9	.102

Straight Flutes - Internal

Thread	Pitch	Ordering Code	EDP No.	Dimensions Inch				No. of Flutes	Teeth	
Min. Dia.	TPI	Internal	VTS	D	D2	L	Le	Z	Zt	h
No.8	36	S1/8".120"-I36UNTM...	80034	1/8	.120	1.654	.250	3	9	.016
No.8	32	S1/8".120"-I32UNTM...	80035	1/8	.120	1.654	.250	3	8	.018
5/16"	32	S1/4".240"-I32UNTM...	80036	1/4	.240	2.244	.562	3	18	.018
No.12	28	S3/16".145"-I28UNTM...	80037	3/16	.145	1.654	.321	3	9	.021
7/16"	28	S5/16".310"-I28UNTM3...	80038	5/16	.310	2.480	.786	3	22	.021
7/16"	28	S5/16".310"-I28UNTM5...	80441	5/16	.310	2.480	.786	5	22	.021
No.12	24	S3/16".160"-I24UNTM...	80039	3/16	.160	2.244	.333	3	8	.024
1/4"	20	S3/16".160"-I20UNTM...	80040	3/16	.160	2.244	.400	3	8	.029
9/16"	20	S3/8".370"-I20UNTM...	80041	3/8	.370	2.835	.900	5	18	.029
5/16"	18	S1/4".200"-I18UNTM...	80440	1/4	.200	2.244	.500	3	9	.033
9/16"	18	S3/8".370"-I18UNTM...	80043	3/8	.370	2.835	.944	5	17	.033
3/8"	16	S1/4".240"-I16UNTM...	80044	1/4	.240	2.244	.562	3	9	.037
13/16"	16	S1/2".470"-I16UNTM...	80045	1/2	.470	3.268	1.125	5	18	.037
7/16"	14	S5/16".310"-I14UNTM3...	80046	5/16	.310	2.480	.714	3	10	.042
7/16"	14	S5/16".310"-I14UNTM5...	80238	5/16	.310	2.480	.714	5	10	.042
1/2"	13	S5/16".310"-I13UNTM3...	80047	5/16	.310	2.480	.769	3	10	.045
1/2"	13	S5/16".310"-I13UNTM5...	80237	5/16	.310	2.480	.769	5	10	.045
9/16"	12	S3/8".370"-I12UNTM...	80048	3/8	.370	2.835	.917	5	11	.049
1"	12	S1/2".470"-I12UNTM...	80049	1/2	.470	3.268	1.167	5	14	.049
5/8"	11	S3/8".370"-I11UNTM...	80050	3/8	.370	2.835	.909	5	10	.053
3/4"	10	S1/2".470"-I10UNTM...	80051	1/2	.470	3.268	1.100	5	11	.059
7/8"	9	S5/8".620"-I9UNTM...	80442	5/8	.620	3.622	1.333	5	12	.065
1"	8	S5/8".620"-I8UNTM...	80053	5/8	.620	3.622	1.500	5	12	.073
1 1/8"	7	S5/8".620"-I7UNTM...	80054	5/8	.620	3.622	1.429	5	10	.084
1 3/8"	6	S3/4".745"-I6UNTM...	80055	3/4	.745	4.095	1.500	5	9	.098
1 3/4"	5	S3/4".745"-I5UNTM...	80057	3/4	.745	4.095	1.600	5	8	.117
2"	4.5	S3/4".745"-I4.5UNTM...	80058	3/4	.745	4.095	1.555	5	7	.130

External / Internal

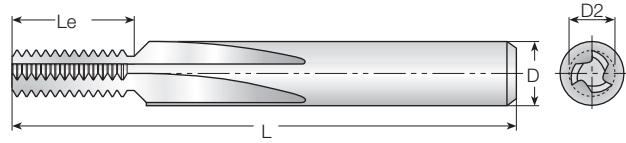
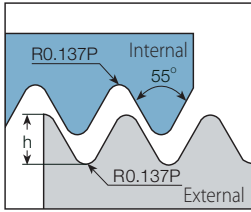

Defined by: B.S.84:1956, DIN 259, ISO228/1:1982
Tolerance class: Medium class A

Straight Flutes

Thread	Pitch	Ordering Code	EDP No.	Dimensions Inch				No. of Flutes	Teeth	
Min. Dia.	TPI	External / Internal	VTS	D	D2	L	Le	Z	Zt	h
1/4"	20	S3/16".160"-EI20BSWTM...	80059	3/16	.160	1.654	.400	3	8	.032
5/16"	18	S1/4".200"-EI18BSWTM...	80060	1/4	.200	2.244	.444	3	8	.035
3/8"	16	S1/4".240"-EI16BSWTM...	80061	1/4	.240	2.244	.562	3	9	.040
7/16"	14	S5/16".310"-EI14BSWTM3...	80062	5/16	.310	2.480	.714	3	10	.046
7/16"	14	S5/16".310"-EI14BSWTM5...	80232	5/16	.310	2.480	.714	5	10	.046
1/2"	12	S5/16".310"-EI12BSWTM3...	80063	5/16	.310	2.480	.750	3	9	.053
1/2"	12	S5/16".310"-EI12BSWTM5...	80447	5/16	.310	2.480	.750	5	9	.053
5/8"	11	S3/8".370"-EI11BSWTM...	80064	3/8	.370	2.835	.909	5	10	.058
3/4"	10	S1/2".470"-EI10BSWTM...	80065	1/2	.470	3.268	1.100	5	11	.064
7/8"	9	S1/2".470"-EI9BSWTM...	80066	1/2	.470	3.268	1.111	5	10	.071
1"	8	S5/8".620"-EI8BSWTM...	80067	5/8	.620	3.622	1.500	5	12	.080
1 1/8"	7	S5/8".620"-EI7BSWTM...	80068	5/8	.620	3.622	1.429	5	10	.091
1 3/8"	6	S5/8".620"-EI6BSWTM...	80069	5/8	.620	3.622	1.500	5	9	.107
1 5/8"	5	S3/4".745"-EI5BSWTM...	80070	3/4	.745	4.095	1.600	5	8	.128
1 7/8"	4.5	S3/4".745"-EI4.5BSWTM...	80071	3/4	.745	4.095	1.555	5	7	.142

External / Internal

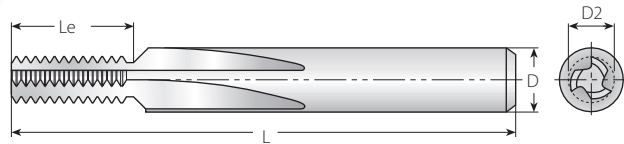
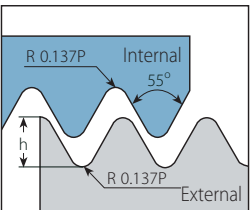

Defined by: B.S.2779:1956
Tolerance class: Medium class

Straight Flutes

Thread	Pitch	Ordering Code	EDP No.	Dimensions Inch				No. of Flutes	Teeth	
Min. Dia.	TPI	External / Internal	VTS	D	D2	L	Le	Z	Zt	h
1/16"	28	S1/4".240"-EI28BSPTM...	80076	1/4	.240	2.244	.571	3	16	.023
1/4"	19	S5/16".310"-EI19BSPTM3...	80073	5/16	.310	2.480	.737	3	14	.034
1/4"	19	S5/16".310"-EI19BSPTM5...	80234	5/16	.310	2.480	.737	5	14	.034
1/2"	14	S1/2".470"-EI14BSPTM...	80074	1/2	.470	3.268	1.143	5	16	.046
1"	11	S5/8".620"-EI11BSPTM...	80075	5/8	.620	3.622	1.364	5	15	.058

BSPT

Straight

External / Internal

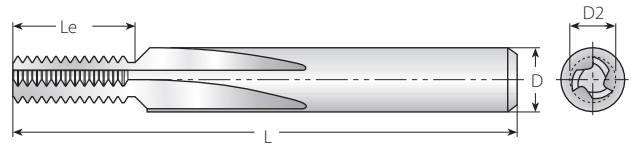
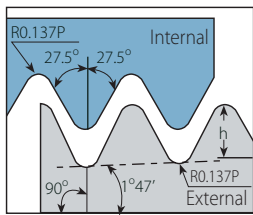

Defined by: B.S.21:1985
Tolerance class: Standard BSPT

Straight Flutes

Thread	Pitch	Ordering Code	EDP No.	Dimensions Inch				No. of Flutes	Teeth	
Min. Dia.	TPI	External / Internal	VTS	D	D2	L	Le	Z	Zt	h
1/16"	28	S1/4".240"-EI28BSPT-TM...	80072	1/4	.240	2.244	.393	3	11	.023
1/4"	19	S5/16".310"-EI19BSPT-TM3...	80077	5/16	.310	2.480	.579	3	11	.034
1/4"	19	S5/16".310"-EI19BSPT-TM5...	80235	5/16	.310	2.480	.579	5	11	.034
1/2"	14	S1/2".470"-EI14BSPT-TM...	80078	1/2	.470	3.268	.786	5	11	.046
1"	11	S5/8".620"-EI11BSPT-TM...	80079	5/8	.620	3.622	1.545	5	17	.058

NPT

Straight

External / Internal

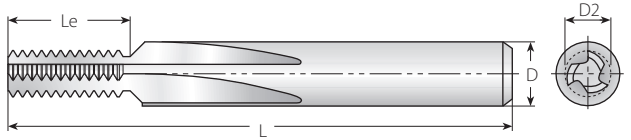
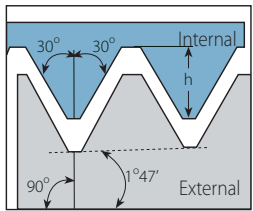

Defined by: USAS B2.1:1968
Tolerance class: Standard NPT

Straight Flutes

Thread	Pitch	Ordering Code	EDP No.	Dimensions Inch				No. of Flutes	Teeth	
Min. Dia.	TPI	External / Internal	VTS	D	D2	L	Le	Z	Zt	h
1/16"	27	S1/4".240"-EI27NPT-TM...	80080	1/4	.240	2.244	.370	3	10	.030
1/4"	18	S5/16".310"-EI18NPT-TM3...	80081	5/16	.310	2.480	.555	3	10	.044
1/4"	18	S5/16".310"-EI18NPT-TM5...	80190	5/16	.310	2.480	.555	5	10	.044
1/2"	14	S1/2".470"-EI14NPT-TM...	80082	1/2	.470	3.268	.786	5	11	.057
1"	11.5	S5/8".620"-EI11.5NPT-TM...	80083	5/8	.620	3.622	1.043	5	12	.070
2 1/2"	8	S5/8".620"-EI8NPT-TM...	80084	5/8	.620	3.622	1.500	5	12	.100

External / Internal

Defined by: MIL-P-7105B
Tolerance class: Standard ANPT

Straight Flutes

Thread	Pitch	Ordering Code	EDP No.	Dimensions Inch				No. of Flutes	Teeth	
Min. Dia.	TPI	External / Internal		D	D2	L	Le	Z	Zt	h
1/4"	18	S5/16".310"-EI18ANPT-TM5...	81056	5/16	.310	2.480	.555	5	10	.044
1/2"	14	S1/2".470"-EI14ANPT-TM...	81057	1/2	.470	3.268	.786	5	11	.057

NPTF

Straight

External / Internal

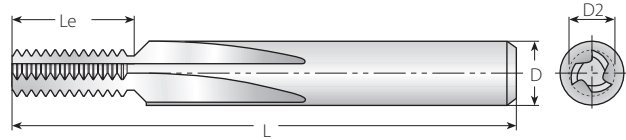
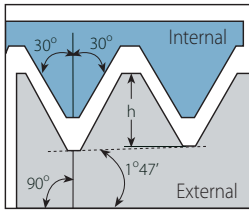

Defined by: ANSI 1.20.3-1976
Tolerance class: Standard NPTF

Straight Flutes

Thread	Pitch	Ordering Code	EDP No.	Dimensions Inch				No. of Flutes	Teeth	
Min. Dia.	TPI	External / Internal	VTS	D	D2	L	Le	Z	Zt	h
1/16"	27	S1/4".240"-EI27NPTFTM...	80085	1/4	.240	2.244	.370	3	10	.030
1/4"	18	S5/16".310"-EI18NPTFTM3...	80086	5/16	.310	2.480	.555	3	10	.044
1/4"	18	S5/16".310"-EI18NPTFTM5...	80233	5/16	.310	2.480	.555	5	10	.044
1/2"	14	S1/2".470"-EI14NPTFTM...	80087	1/2	.470	3.268	.786	5	11	.057
1"	11.5	S5/8".620"-EI11.5NPTFTM...	80088	5/8	.620	3.622	1.043	5	12	.070
2 1/2"	8	S5/8".620"-EI8NPTFTM...	80089	5/8	.620	3.622	1.500	5	12	.100

Pg

Straight

External / Internal

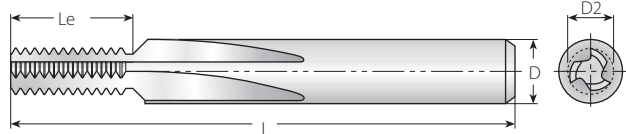
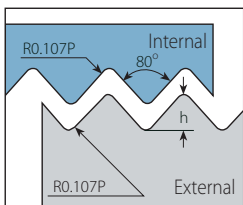

Defined by: DIN 40430
Tolerance class: Standard

Straight Flutes

Thread	Pitch	Ordering Code	EDP No.	Dimensions Inch				No. of Flutes	Teeth	
	TPI	External / Internal	VTS	D	D2	L	Le	Z	Zt	h
Pg7	20	S5/16".310"-EI20PGTM3...	80090	5/16	.310	2.480	.750	3	15	.024
Pg7	20	S5/16".310"-EI20PGTM5...	80448	5/16	.310	2.480	.750	5	15	.024
Pg9, 11, 13.5, 16	18	S3/8".370"-EI18PGTM...	80091	3/8	.370	2.835	.944	5	17	.026
Pg21, 29, 36, 42, 48	16	S1/2".470"-EI16PGTM...	80092	1/2	.470	3.268	1.125	5	18	.030

Grades and Their Applications

VTH

Helicool HCR HCC

MilliPro MilliPro Dental MilliPro HD

MilliPro EL Deep Threading Helical

- A general-purpose, heavy duty thread milling grade
- TiCN coated for high resistance to wear

VTS

Straight

- A general-purpose grade, specially designed for TM Solid Straight Flute cutters
- TiAlN coated for high resistance to wear

VTS

HTC (Thriller)

- TiAlN coated grade
- First choice for Cast Iron and general use

VTN

HTC (Thriller)

- Uncoated grade
- First choice for Aluminium and general use



TM Solid

Recommended Cutting Speeds Vc [ft/min] and Feed f [inch/tooth] (Not Including HTC & MilliPro HD)

Material Group	Vargus No.	Material	Hardness Brinell HB	Vc [ft/min]			Feed [inch/tooth]					
				Helicoil, HCR, HCC, Helical, Straight, Deep Threading		MilliPro	He-Lex	Straight	Deep Threading	Helicoil HCC HCR	MilliPro	
				VTH	VTS	VTH						
P Steel	1	Unalloyed Steel	Low Carbon (C=0.1-0.25%)	125	262-820	164-590	197-393	.0012-.0031	.0012-.0031	.0039-.0138	.0012-.0031	.0008-.0063
	2		Medium Carbon (C=0.25-0.55%)	150	262-754	164-459	197-393	.0012-.0031	.0012-.0031	.0031-.0118	.0012-.0031	.0008-.0063
	3		High Carbon (C=0.55-0.85%)	170	262-656	164-393	197-295	.0012-.0031	.0012-.0024	.0031-.0118	.0012-.0031	.0008-.0063
	4	Low Alloy Steel (alloying elements ≤5%)	Non Hardened	180	197-590	197-557	197-295	.0012-.0031	.0012-.0028	.0031-.0118	.0012-.0031	.0008-.0063
	5		Hardened	275	197-557	197-525	164-262	.0012-.0028	.0012-.0028	.0031-.0118	.0012-.0028	.0008-.0028
	6		Hardened	350	197-525	197-492	164-262	.0008-.002	.0008-.0016	.002-.0059	.0008-.0024	.0008-.0012
	7	High Alloy Steel (alloying elements >5%)	Annealed	200	131-328	131-295	164-262	.0012-.0028	.0012-.0028	.0039-.0094	.0012-.0028	.0008-.0035
	8		Hardened	325	98-262	98-230	164-262	.0008-.0016	.0008-.002	.002-.0059	.0012-.0024	.0008-.0012
	9	Cast Steel	Low Alloy (alloying elements <5%)	200	262-820	230-656	230-295	.0012-.0031	.0012-.0024	.0031-.0118	.0012-.0028	.0008-.0063
	10		High Alloy (alloying elements >5%)	225	197-557	197-492	197-262	.0012-.002	.0012-.0024	.002-.0059	.0012-.0028	.0008-.0012
M Stainless Steel	11	Stainless Steel Ferritic	Non Hardened	200	197-492	164-459	197-295	.0016-.0028	.0008-.002	.0043-.0138	.0012-.0031	.0008-.0063
	12		Hardened	330	197-393	164-361	164-262	.0008-.0024	.0004-.0012	.002-.0094	.0012-.0024	.0008-.0012
	13	Stainless Steel Austenitic	Austenitic	180	197-459	197-426	197-295	.0012-.0031	.0008-.002	.0043-.0138	.0012-.0031	.0008-.0063
	14		Super Austenitic	200	197-426	164-393	164-262	.0012-.0031	.0008-.002	.0043-.0138	.0012-.0024	.0008-.0063
	15	Stainless Steel Cast Ferritic	Non Hardened	200	197-525	164-492	197-295	.0012-.0031	.0008-.002	.0043-.0138	.0012-.0024	.0008-.0063
	16		Hardened	330	197-361	164-328	164-262	.0008-.002	.0008-.0012	.0039-.0094	.0008-.002	.0008-.0012
	17	Stainless Steel Cast Austenitic	Austenitic	200	197-492	164-459	197-295	.0012-.0031	.0008-.0024	.0043-.0138	.0008-.002	.0008-.0063
	18		Hardened	330	197-328	164-295	164-262	.0008-.002	.0004-.0012	.0039-.0094	.0008-.0016	.0008-.0012
K Cast Iron	28	Malleable Cast Iron	Ferritic (short chips)	130	197-230	197-492	164-262	.0012-.0031	.0012-.0031	.002-.0059	.0012-.0031	.0008-.0012
	29		Pearlitic (long chips)	230	197-492	262-328	197-295	.0012-.0031	.0012-.0024	.0039-.0094	.0012-.0028	.0008-.0047
	30	Grey Cast Iron	Low Tensile Strength	180	230-525	164-459	230-328	.0012-.0031	.0012-.0024	.0035-.0098	.0012-.0028	.0008-.0063
	31		High Tensile Strength	260	131-393	131-361	197-295	.0008-.0024	.0008-.002	.0039-.0094	.0012-.0028	.0008-.0047
	32	Nodular Sg Iron	Ferritic	160	131-361	131-328	230-328	.0012-.0031	.0012-.0028	.0035-.0098	.0012-.0031	.0008-.0063
	33		Pearlitic	260	131-328	131-295	197-295	.0008-.0024	.0008-.002	.0039-.0094	.0012-.0028	.0008-.0047
N Non-Ferrous Metals	34	Aluminium Alloys Wrought	Non Aging	60	656-984	492-820	197-820	.002-.0047	.002-.0059	.0047-.0157	.0016-.0039	.0012-.0059
	35		Aged	100	492-820	328-721	197-492	.002-.0047	.0012-.0039	.0039-.0126	.0012-.0039	.0012-.0063
	36	Aluminium Alloys	Cast	75	328-656	262-492	197-820	.002-.0047	.002-.0059	.0039-.0126	.0012-.0039	.0012-.0063
	37		Cast & Aged	90	393-721	295-525	197-492	.002-.0047	.0012-.0039	.0039-.0118	.0024-.0047	.0008-.0063
	38		Aluminium Alloys Cast Si 13-22%	130	656-984	492-820	820	.002-.0047	.002-.0059	.0039-.0126	.002-.0047	.0012-.0059
	39	Copper and Copper Alloys	Brass	90	656-984	492-820	197-820	.0024-.0051	.002-.0059	.0047-.0157	.002-.0047	.0012-.0063
	40		Bronze And Non Leaded Copper	100	492-820	328-721	197-492	.002-.0047	.0012-.0039	.0039-.0126	.002-.0047	.0012-.0059
S Heat Resistant Material	19	High Temperature Alloys	Annealed (iron based)	200	98-197	98-164	197	.0012-.0028	.0008-.0016	.0043-.0138	.0012-.0276	.0008-.0063
	20		Aged (iron based)	280	66-164	66-131	164	.0008-.0016	.0004-.0012	.002-.0059	.0012-.0024	.0008-.0012
	21		Annealed (nickel or cobalt based)	250	49-115	49-98	115	.0008-.0016	.0004-.0012	.002-.0059	.0012-.0024	.0008-.0012
	22		Aged (nickel or cobalt based)	350	49-98	49-82	98	.0008-.0016	.0004-.0012	.002-.0059	.0008-.002	.0008-.0012
	23	Titanium Alloys	Pure 99.5 Ti	400Rm	131-262	98-230	98-164	.0008-.0016	.0004-.0012	.0039-.0094	.0008-.002	.0008-.0028
24	α+β Alloys		1050Rm	66-164	66-148	82-115	.0008-.0016	.0004-.0008	.0039-.0094	.0008-.0016	.0008-.0028	
H Hardened Material	25	Extra Hard Steel	Hardened & Tempered	45-50Hrc	49-148	49-115	148	.0008-.0012	.0008	.0012-.0024	.0008-.0012	-
	26			51-55Hrc	49-131	49-98	98	.0008-.0012	.0004	.0012-.0024	.0008-.0012	-

Recommendation:
At tool entry, set the Feed f [inch/tooth] to 70% lower than the threading Feed.

Example:
Threading Feed: .012[inch/tooth]
Tool entry Feed: .0035[inch/tooth]

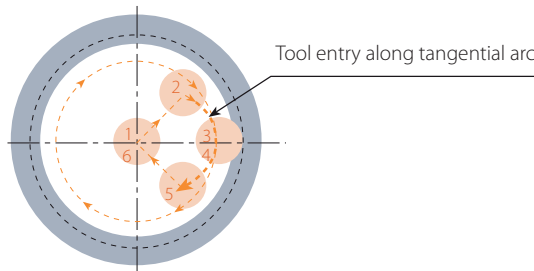

MilliPro HD Cutting Speeds Vc [ft/min] and Feed f [inch/tooth]

Material Group	Vargus No.	Material	Hardness Brinell HB	Vc [ft/min] Feed f [inch/tooth] by Cutting Dia.=D2						
				VTH	.06-.10	.10-.20	.20-.30	.30-.35	.35-.45	
P Steel	6	Low Alloy Steel (alloying elements≤5%) Hardened	350	82-525	.0016	.0020	.0024	.0028	.0031	
	8	High Alloy Steel (alloying elements>5%) Hardened	325	82-591						
M Stainless Steel	12	Stainless Steel Ferritic Hardened	330	82-394	.0016	.0020	.0024	.0028	.0031	
	16	Stainless Steel Cast Ferritic Hardened	330	82-361						
	18	Stainless Steel Cast Austenitic Hardened	330	82-328						
K Cast Iron	28	Malleable Cast Iron	Ferritic (short chips)	130	82-525	.0020	.0024	.0028	.0031	.0039
	29		Pearlitic (long chips)	230	82-492	.0016	.0020	.0024	.0028	.0031
	30	Grey Cast Iron	Low Tensile Strength	180	82-427	.0020	.0024	.0028	.0031	.0039
	31		High Tensile Strength	260	82-328	.0016	.0020	.0024	.0028	.0031
	32	Nodular Sg Iron	Ferritic	160	82-410	.0016	.0020	.0024	.0028	.0035
	33		Pearlitic	260	82-295	.0012	.0016	.0020	.0024	.0028
S Heat Resistant Material	21	High Temperature Alloys	Annealed (nickel or cobalt based)	250	49-115	.0012	.0016	.0020	.0024	.0028
	22		Aged (nickel or cobalt based)	350	49-98					
	23	Titanium Alloys	Pure 99.5 Ti	400Rm	82-230					
	24		α+β alloys	1050Rm	82-164					
H Hardened Material	25	Extra Hard Steel	Hardened & Tempered	45-50HRC	82-230	.0016	.0020	.0024	.0028	.0031
	26			51-55HRC	82-197	.0012	.0016	.0020	.0024	.0028
	27			56-62HRC	82-164	.0008	.0012	.0016	.0020	.0024

HTC Recommended Grades, Cutting Speed and Feed

Material Group	Material	Hardness Brinell HB	Strength (N-mm ²)	Vc[ft/min]		fb[Inch/rev]		fz[inch/tooth]		
				VTN	VTS	≤.24 inch	≤.47 inch	≤.24 inch	≤.47 inch	
K Cast Iron	Cast Iron	Grey Cast Iron	≤150	≤500	164-262	262-394	.004-.006	.006-.009	.001-.002	.002-.004
		Grey Cast Iron, Heat Treated	150-300	500-1000	164-262	262-394	.004-.006	.006-.009	.001-.002	.002-.004
		Spher. Graph. Cast Iron	≤200	≤700	164-262	262-394	.004-.006	.006-.009	.001-.002	.002-.004
N Non-Ferrous Metals	Aluminium/Magnesium	Copper	≤200	≤700	328-984	—	.002-.004	.004-.012	.001-.002	.002-.004
		Aluminium, Magnesium Non-Alloy	≤100	≤350	328-1,312	328-1,312	.004-.010	.010-.012	.001-.002	.002-.004
		Aluminium, Wrought Alloy, Breaking Strain (A5) < 14%	≤180	≤600	328-1,312	328-1,312	.004-.010	.010-.012	.001-.002	.002-.004
		Aluminium, Wrought Alloy, Breaking Strain (A5) ≥ 14%	≤180	≤600	328-1,312	328-1,312	.001-.002	.002-.005	.001-.002	.002-.004
		Aluminium, Cast Alloy, Si<10%	≤180	≤600	328-984	328-1,312	.004-.010	.010-.012	.001-.002	.002-.004
		Aluminium, Cast Alloy, Si≥10%	≤180	≤600	—	328-984	.004-.010	.010-.012	.001-.002	.002-.004
K Plastic	Plastic	Thermo Plastics	—	—	197-394	197-394	.004-.010	.010-.012	.001-.002	.002-.004
		Thermosetting Plastic	—	—	197-328	197-328	.004-.010	.010-.012	.001-.002	.002-.004
		Fiber Reinforced Plastic	—	—	131-197	197-262	.004-.006	.006-.009	.001-.002	.002-.004

Vc - Cutting Speed [ft/min]

fb - (Drilling) - Feed per Revolution [inch/rev]

fz - (Threading) - Feed per Tooth [inch/tooth]

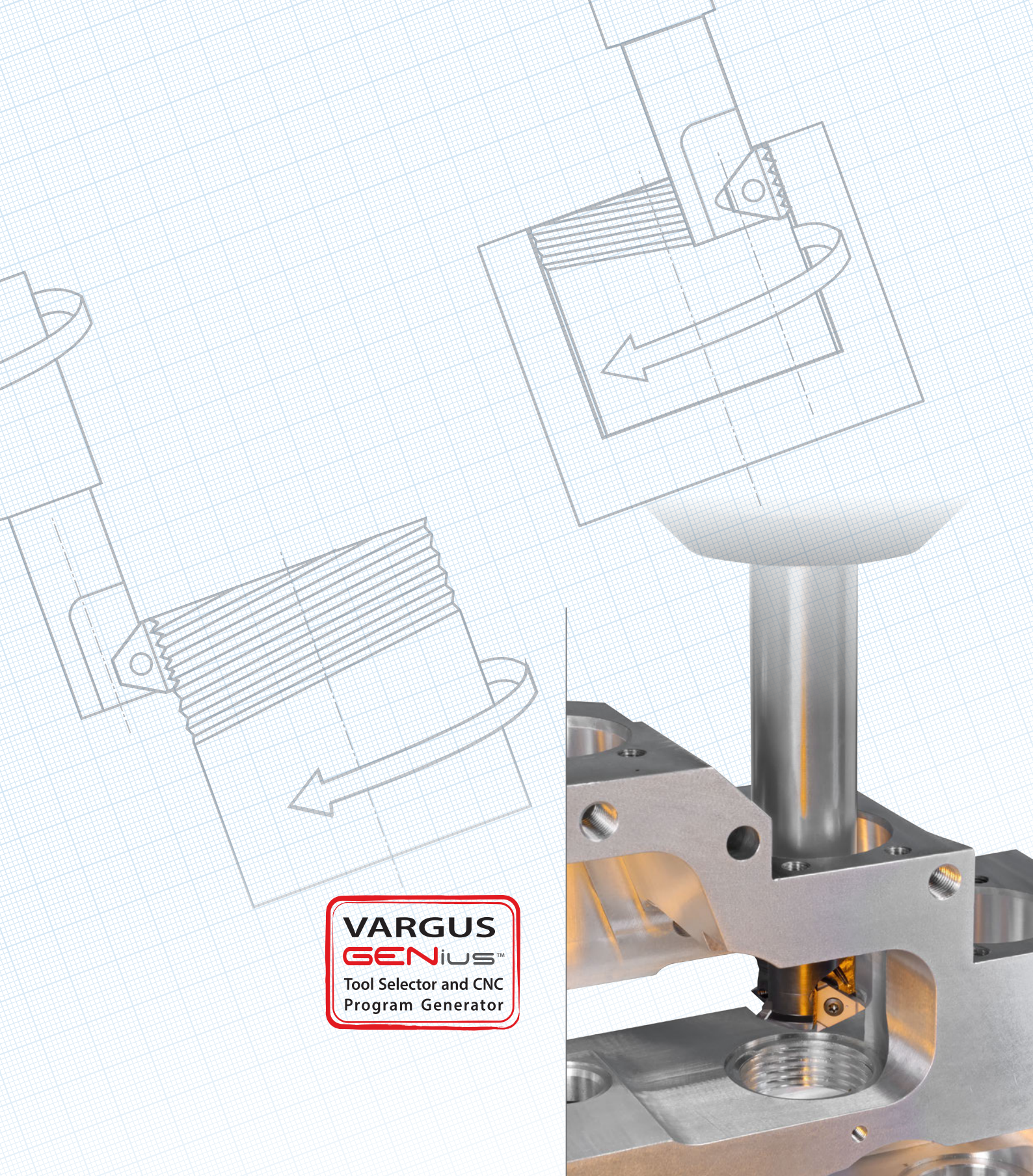

VARGUS
GENiUS™
Tool Selector and CNC
Program Generator

Thread Milling Technical Data

About Thread Milling

To perform a thread milling operation, a milling machine with three-axis control capable of helical interpolation is required. Helical interpolation is a CNC function producing tool movement along a helical path. This helical motion combines circular movement in one plane with a simultaneous linear motion in a plane perpendicular to the first. For example, the path from point A to point B (Fig. A) on the envelope of the cylinder combines a circular movement in the xy plane with a linear displacement in the z direction. On most CNC systems this function can be executed in two different ways:

- G02: Helical interpolation in a clockwise direction
- G03: Helical interpolation in a counter-clockwise direction

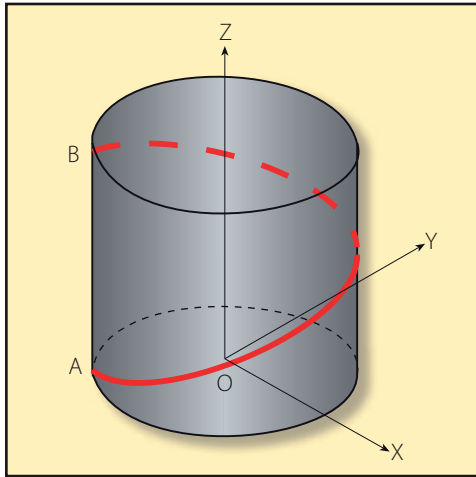

Fig. A

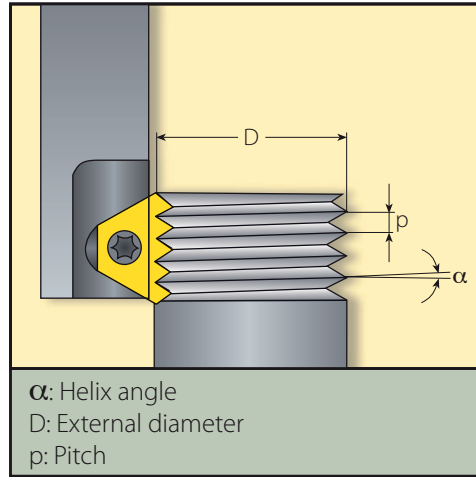

Fig. B

The thread milling operation (Fig. B) consists of circular rotation of the tool around its own axis together with an orbiting motion along the bore or workpiece circumference. During one such orbit, the tool will shift vertically one pitch length. These movements combined with the insert geometry create the required thread form.

There are three acceptable ways of approaching the workpiece with the tool to initiate production of the thread:

- 1 Tangential Arc Approach
- 2 Radial Approach
- 3 Tangential Line Approach

1 Tangential Arc Approach

With this method, the tool enters and exits the workpiece smoothly. No marks are left on the workpiece and there is no vibration, even with harder materials.

Although it requires slightly more complex programming than the radial approach (see below), this is the method recommended for machining the highest quality threads.

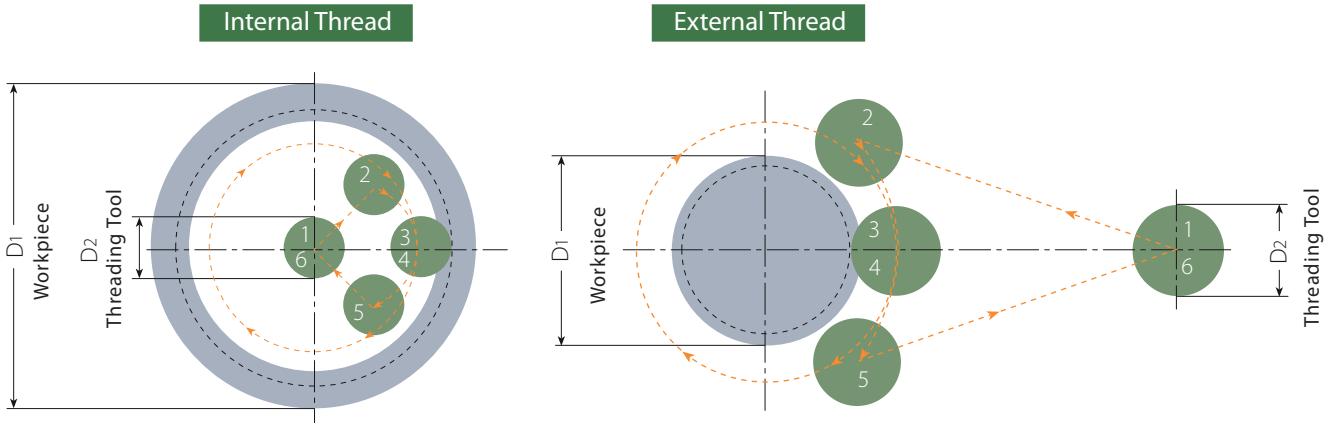

1-2: Rapid approach

2-3: Tool entry along tangential arc, with simultaneous feed along z-axis

3-4: Helical movement during one full orbit (360°)

4-5: Tool exit along tangential arc, with continuing feed along z-axis

5-6: Rapid return

2 Radial Approach

This is the simplest method. There are two characteristics worth noting about the radial approach:

1. A small vertical mark may be left at the entry (and exit) point. This is of no significance to the thread itself.

2. When using this method with very hard materials, there may be a tendency of the tool to vibrate as it approaches the full cutting depth.

Note: Radial feed during entry to the full profile depth should only be $\frac{1}{3}$ of the subsequent circular feed.

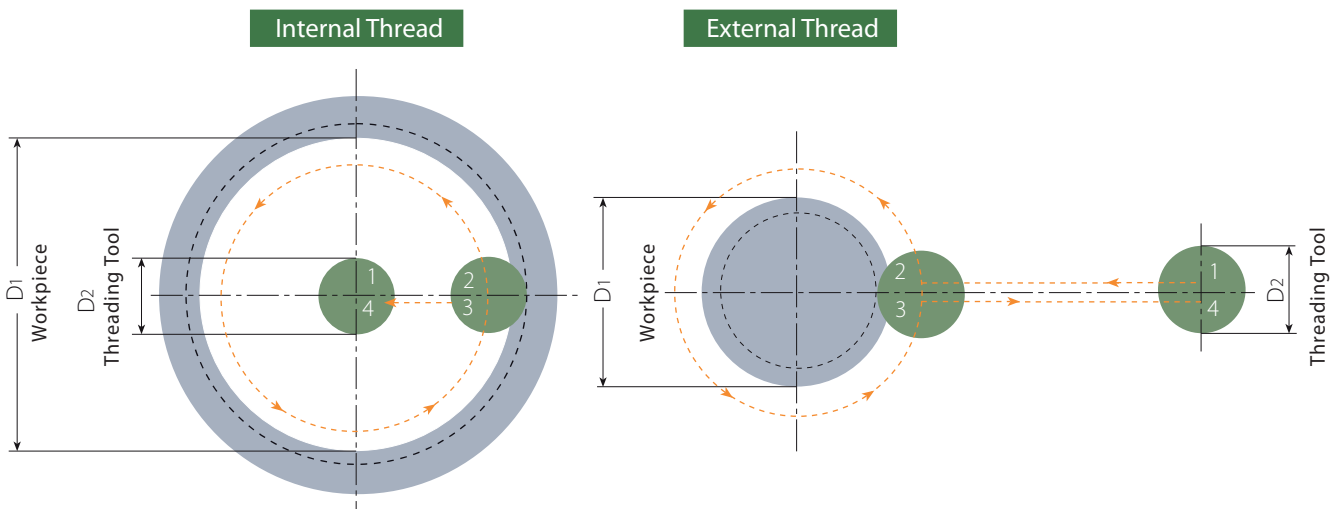

1-2: Radial entry

2-3: Helical movement during one full orbit (360°)

3-4: Radial exit

3 Tangential Line Approach

This method is very simple, and has all of the advantages of the tangential arc method. However, it is applicable only with external threads.

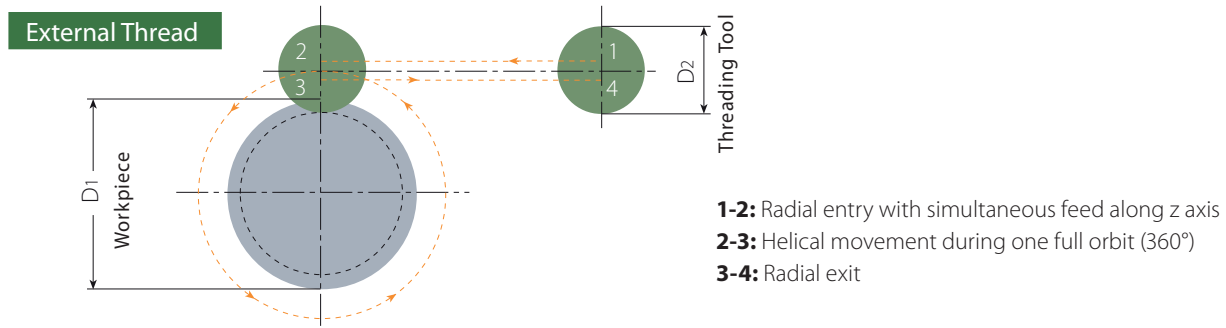

Preparing for the Thread Milling Operation

1 Calculation of Rotational Velocity and Feed at the Cutting Edge

$$N = \frac{12 \times V}{\pi \times D_2}$$

$$V = \frac{N \times \pi \times D_2}{12}$$

$$F_1 = N \times z \times f$$

N - Rotational Velocity [R.P.M.]
 V - Cutting Speed [ft/min]
 D₂ - Toolholder Cutting Dia. [Inch]
 F₁ - Tool Feed Rate at the Cutting Edge [Inch/min]
 z - No. of Cutting Edges
 f - Feed per Tooth per Rotation [inch/tooth]

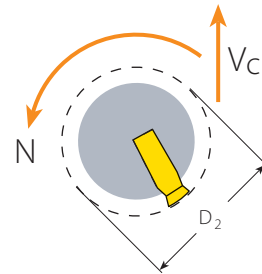

2 Calculation of Feed Rates at the Tool Center Line

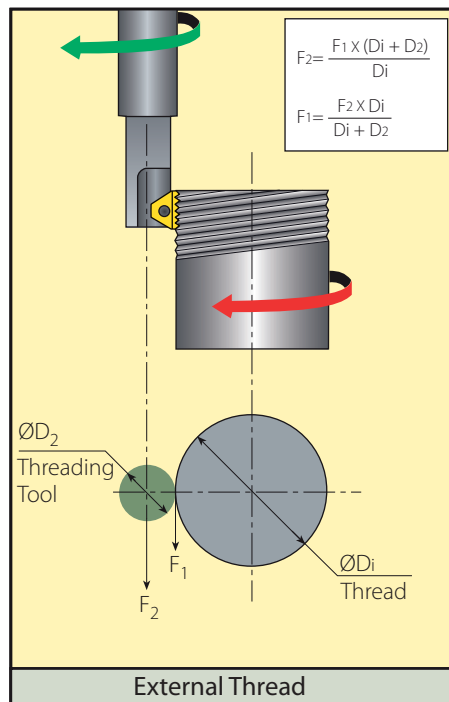
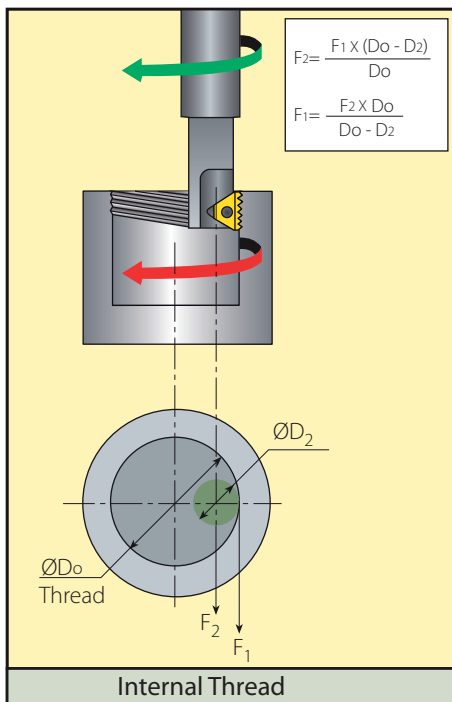

The equations define the relationship between feed rates at the cutting edge and at the tool center line. On most CNC machines the feed rate required for programming is that of the center-line of the tool. When dealing with linear tool movement the feed rate at the cutting edge and the center line are identical. This is not the case with circular tool movement.

List of "G" Codes (ISO) for CNC Program

Code	Description	Code	Description
%	Recognition code (ISO or EIA) + End of tape	H	Tool length compensation number
G00	Fast feed linear positioning	D	Tool radius compensation number
G01	Linear interpolation	X	X coordinate
G02	Circular/Helical interpolation CW	Y	Y coordinate
G03	Circular/Helical interpolation CCW	Z	Z coordinate
G40	Cutter radius compensation cancel	R	Radius of travel
G41	Cutter radius compensation left	I	X coordinate to center of starting arc travel
G42	Cutter radius compensation right	J	Y coordinate to center of starting arc travel
G43	Tool length compensation +	M3	Spindle forward rotation
G49	Tool length compensation cancel	M5	Spindle stop
G57	Work coordinate system selection	M30	Program end & rewind
G90	Absolute command relative to work coordinate origin	O	Program number
G91	Incremental command relative to tool position	N	Block number (can be avoided)
F	Feed Inch/min	(Start of comment
S	Spindle speed RPM)	End of comment

CNC Program Sample (Thread: M60 x 1.5 x 20)

```

%
O0001 (TMINRH CLIMB CYCLES = 1)..... Program no.
(Fanuc 11M Controller.) ..... Remark
G90 G00 G57 X0 Y0..... Home (origin) set
G43 H10 Z0 M3 S946 ..... Tool length compensation-on and RPM set
G91 G00 X0 Y0 Z-0.7981 ..... Go down in Z-axis
G41 D60 X0.3724 Y-0.8108 Z0..... Tool diameter compensation-on
G91 G03 X0.8108 Y0.8108 Z0.0107 R0.8108 F1.4173 ..... Entrance by tangential arc
G91 G03 X0 Y0 Z0.0591 I-1.1832 J0 ..... Thread machining-HELICAL interpolation movement
G91 G03 X-0.8108 Y0.8108 Z0.0107 R0.8108 ..... Exit by tangential arc
G00 G40 X-0.3724 Y-0.8108 Z0 ..... Tool diameter compensation-off
G90 G49 G57 G00 Z7.874 M5 ..... Tool length compensation-off and RPM close
M30 ..... End of program
%
  
```

Recommendation:

At tool entry, set the Feed f [inch/tooth] to 70% lower than the threading Feed.

Example:

Threading Feed: .0012[inch/tooth]
 Tool entry Feed: .0036[inch/tooth]

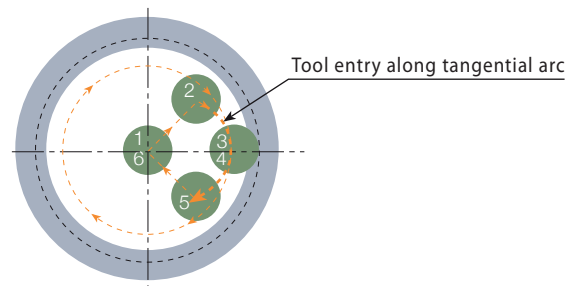

Minimum Bore Diameters for TM Standard line

Pitch mm		0.5	0.6	0.7	0.75 0.80	0.9	1.0	1.25	1.5	1.75	2.0		2.5	3.0	3.5	4.0	4.5	5.0	5.5		6.0			
Pitch TPI		48	44	36	32	28	26 24	20 19	18 16	14	13 12	11.5 11	10	9 8	7	6		5		4.5		4		
Toolholder Ordering Code	D2	Minimum Bore Diameter Di Inch																						
TMMC050-6.0	.35	.37	.38	.39	.39	.41	.42	.45	.47															
TMMC075-6.0	.35	.37	.38	.39	.39	.41	.42	.45	.47															
TMMC075-6.0124/203	.35	.37	.38	.39	.39	.41	.42	.45	.47															
TMC050-2	.45	.47	.48	.49	.49	.51	.52	.55	.57	.59														
TMC075-2	.45	.47	.48	.49	.49	.51	.52	.55	.57	.59														
TMLC100-2	.45	.47	.48	.49	.49	.51	.52	.55	.57	.59														
TMSC0375-2	.49	.51	.50	.54	.53	.55	.56	.59	.61	.63														
TMOC075-2	.57	.59	.60	.6	.61	.63	.65	.67	.70	.73														
TMNC0625-3	.61	.63	.64	.65	.65	.67	.68	.70	.73	.75	.77	.79												
TMC075-3124/201	.61	.63	.64	.65	.65	.67	.68	.70	.73	.75	.77	.79												
TMC0625-3	.67	.69	.70	.71	.72	.74	.75	.77	.79	.81	.83	.85												
BTMC0625-3B	.67	.69	.70	.71	.72	.74	.75	.77	.79	.81	.83	.85												
TM2C075-2	.67	.69	.70	.71	.72	.74	.75	.77	.79	.81														
BTMC075-3B	.75	.78	.79	.80	.80	.82	.83	.85	.87	.89	.91	.93												
TMNC075-3	.75	.78	.79	.80	.80	.82	.83	.85	.87	.89	.91	.93												
TMC075-3	.79	.81	.83	.83	.84	.86	.87	.89	.91	.93	.94	.96												
TMOC075-3	.79	.81	.83	.83	.84	.86	.87	.89	.91	.93	.94	.96												
BTMWC100-3B	.87	.89	.91	.91	.92	.94	.94	.97	.98	1.00	1.02	1.04												
BTMLC100-3B	.87	.89	.91	.91	.92	.94	.94	.97	.98	1.00	1.02	1.04												
TMLC100-3	.87	.89	.91	.91	.92	.94	.94	.97	.98	1.00	1.02	1.04												
TMC100-5124/204	.98	1.01	1.02	1.03	1.04	1.06	1.06	1.09	1.11	1.13	1.15	1.17	1.23	1.33	1.44	1.56	1.68							
TM2C100-3	1.02	1.05	1.06	1.07	1.08	1.09	1.10	1.13	1.15	1.17	1.19	1.21												
BTM2C100-3B	1.02	1.05	1.06	1.07	1.08	1.09	1.10	1.13	1.15	1.17	1.19	1.21												
TMC100-5	1.18	1.21	1.22	1.23	1.24	1.25	1.26	1.29	1.32	1.34	1.36	1.40	1.44	1.54	1.65	1.77	1.89							
TMLC100-5	1.18	1.21	1.22	1.23	1.24	1.25	1.26	1.29	1.32	1.34	1.36	1.40	1.44	1.54	1.65	1.77	1.89							
TMOC100-5	1.18	1.21	1.22	1.23	1.24	1.25	1.26	1.29	1.32	1.34	1.36	1.40	1.44	1.54	1.65	1.77	1.89							
TMC125-6B	1.38								1.52	1.54	1.56	1.60	1.65	1.73	1.85	1.97	2.10	1.67	1.97	1.76	2.26	2.23		
TMC125-5	1.46	1.50	1.50	1.51	1.52	1.54	1.56	1.59	1.61	1.63	1.65	1.69	1.73	1.83	1.93	2.05	2.19							
TMLC125-5	1.46	1.50	1.50	1.51	1.52	1.54	1.56	1.59	1.61	1.63	1.65	1.69	1.73	1.83	1.93	2.05	2.19							
TMNC125-5	1.46	1.50	1.50	1.51	1.52	1.54	1.56	1.57	1.61	1.63	1.65	1.69	1.73	1.83	1.93	2.05	2.19							
TMSHD150-050-2	1.50	1.52	1.52	1.53	1.54	1.56	1.57	1.61	1.65	1.69														
TM2C125-5	1.65	1.70	1.71	1.72	1.72	1.75	1.77	1.81	1.83	1.85	1.87	1.90	1.93	2.05	2.15	2.26	2.40							
TMVC125-5	1.81																						2.46	
TMC150-6B	1.81								1.95	1.97	1.99	2.03	2.09	2.17	2.17	2.19	2.17	2.07	2.13	2.15	2.26	2.23		
TMLC150-6B	1.81								1.95	1.97	1.99	2.03	2.09	2.17	2.17	2.19	2.17	2.07	2.13	2.15	2.26	2.23		
TMSHD200-075-2	1.97	1.99	2.00	2.00	2.01	2.03	2.05	2.09	2.13	2.15														
TMSHD200-075-3	1.97	1.99	2.00	2.00	2.01	2.03	2.05	2.09	2.13	2.15	2.17	2.19												

Thread Milling
Technical Data

Minimum Bore Diameters for TM Standard line (con't)

Pitch mm	0.5	0.6	0.7	0.75 0.80	0.9	1.0	1.25	1.5	1.75	2.0		2.5	3.0	3.5	4.0	4.5	5.0	5.5		6.0										
Pitch TPI	48	44	36	32	28	26 24	20 19	18 16	14	13 12	11.5 11	10	9 8	7	6		5			4.5		4								
Toolholder Ordering Code	D2									Minimum Bore Diameter Di Inch																				
TM2C150-6B	2.05								2.20	2.21	2.22	2.24	2.32	2.42		2.48	2.52	2.60	2.64	2.66	2.72	2.76								
TMSHD250-075-3B	2.48	2.5	2.51	2.52	2.52	2.54	2.56	2.6	2.64	2.66	2.68	2.72																		
TMSHD250-075-5	2.48	2.5	2.51	2.52	2.52	2.54	2.56	2.6	2.64	2.66	2.68	2.72	2.76	2.83	2.87	2.91	2.95													
TMSHD250-075-6B	2.48								2.64	2.66	2.68	2.72	2.76	2.83	2.87	2.91	2.95	3.03	3.07	3.09	3.15	3.19								
TMSHD300-100-5	3.15	3.17	3.18	3.19	3.19	3.21	3.23	3.27	3.31	3.33	3.35	3.39	3.43	3.50	3.54	3.58	3.62													
TMSHD300-100-6B	3.15								3.31	3.33	3.35	3.39	3.43	3.50	3.54	3.58	3.62	3.70	3.74	3.76	3.82	3.86								
TMSHD400-125-5	3.94	3.96	3.96	3.97	3.98	4.00	4.02	4.06	4.09	4.11	4.13	4.17	4.21	4.29	4.33	4.37	4.41													
TMSHD400-125-6B	3.94								4.09	4.11	4.13	4.17	4.21	4.29	4.33	4.37	4.41	4.49	4.53	4.55	4.61	4.65								
TMSHD500-150-5	4.92	4.94	4.95	4.96	4.96	4.98	5.00	5.04	5.08	5.10	5.12	5.16	5.20	5.28	5.31	5.35	5.39													
TMSHD500-50-6B	4.92								5.08	5.10	5.12	5.16	5.20	5.28	5.31	5.35	5.39	5.47	5.51	5.54	5.59	5.63								

Coarse Pitch Tooling:

This table is not applicable to the Coarse Pitch system, which can thread mill bores smaller than those listed above.

See the Coarse Pitch section of the various thread standards.

Spare Parts for TM Standard Line

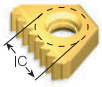

Insert Screw



IC	Holder	Holder Screw	Designation	Thread	Torx Key	Torx Size
6.0mm	TMMC...-6.0		SN7T	M2.2x0.45x5.0	K7T	T7
1/4"	TM.C...-2		SN2TM	M2.6x0.45x5.9	K2T	T8
3/8"	TM.C...-3, TMC...-3 124/...		SN3T, SN3TM	5-40UNCx8.8, 7.3	K3T	T10
3/8"B	BTM.C...-3B		SN3T	5-40UNCx8.8	K3T	T10
1/2"	TMC...-4 124/...		SN4TM, SA4TM	8-32UNCx9.8, 10.7	K4T	T20
5/8"	TM.C...-5, TMC...-5 124/...		SN5TM, SA5TM	M5x0.8x15.0	K5T	T25
3/4"B	TM.C...-6B		SM7T	M7x1.0x15.0	K30T	T30
1/4"	TMSH-D150-050-2	1/4 X 28	SN2T	M2.6x0.45x6.5	HK2T	T8
1/4"	TMSH-D200-075-2		SN2T	M2.6x0.45x6.5	HK2T	T8
3/8"	TMSH-D200-075-3		SN3TM	5-40UNCx7.3	HK3T	T10
3/8"B	TMSH-D250-075-3B	3/8 X 24	SN3TM	5-40UNCx7.3	HK3T	T10
5/8"	TMSH-D250-075-5		SN5TM	M5x0.8x15.0	HK5T	T25
3/4"B	TMSH-D250-075-6B		SM7T	M7x1.0x15.0	HK7T	T30
5/8"	TMSH-D300-100-5	1/2 X 20	SN5TM	M5x0.8x15.0	HK5T	T25
3/4"B	TMSH-D300-100-6B		SM7T	M7x1.0x15.0	HK7T	T30
5/8"	TMSH-D400-125-5	5/8 X 18	SN5TM	M5x0.8x15.0	HK5T	T25
3/4"B	TMSH-D400-125-6B		SM7T	M7x1.0x15.0	HK7T	T30
5/8"	TMSH-D500-150-5	3/4 X 16	SN5TM	M5x0.8x15.0	HK5T	T25
3/4"B	TMSH-D500-150-6B		SM7T	M7x1.0x15.0	HK7T	T30
1/4"	TMSC0375-2		SN2TK	M2.6x0.45x5.9	K2T	T8
5/8"V	TMVC125-5		SN6T	M6x1.0x29.0	K6T	T20

Spare Parts for MiTM Line



Insert Screw



Insert Size	Holder	Holder Screw	Designation	Thread	Torx Key	Torx Size
19	RTMC...A		SLD3IP6	M3x0.5	KIP6	Torx+6
24	RTMC...M		SLD4IP8	M4x0.7	KIP8	Torx+8
25	RTMC...S RTMC-D...S		SLD4IP8	M4x0.7	KIP8	Torx+8
40	RTMC...L RTMC-D...L		SLD4IP8A SCD4IP8	M4x0.7	KIP8	Torx+8
41	RTMC...B RTMC-D...B		SLD4IP8A SCD4IP8	M4x0.7	KIP8	Torx+8
25	RTMC-D150-050-25S5	1/4"-28x1.25	SLD4IP8	M4x0.7	KIP8	Torx+8
	RTMC-D190-075-25S7	3/8"-24x1.25				
	RTMC-D230-100-25S9	1/2"-20x1.50				
	RTMNC-D150-050-25S5	1/4"-28x1.25				
40	RTMCD190-075-40L7	3/8"-24x1.25	SLD4IP8A SCD4IP8	M4x0.7	KIP8	Torx+8
	RTMCD230-100-40L9	1/2"-20x1.50				
	RTMNCD190-075-40L7	3/8"-24x1.25				
41	RTMCD209-075-41B5	3/8"-24x1.5	SLD4IP8A SCD4IP8	M4x0.7	KIP8	Torx+8
	RTMCD248-100-41B6	1/2"-20x1.5				

Spare Parts for TMSD Line



IC	Holder	Holder Screw	Designation	Thread	Torx Key	Blade	Handle	Torx Size
7V	GMC...-7-3 CGMC...-7-3		SN2T8-M1	M3.0x0.5x9	K2T			T8
9V	GMC...-9-3 CGMC...-9-3		SN2T15-M2	M4x0.7x13.5	-	Blade T15-1/4	Smart Handle 1/4x2	T15
11V	GMC...-11-3 CGMC...-11-3		SN4T20-M3	M55x0.8x15.5	-	Blade T20-1/4	Smart Handle 1/4x2	T20
1/4"U, 1/4"A	TM.C....-2U CTMC....-2U or 2A		SN2T	M2.6x0.45x6.5	HK2T			T8
3/8"U, 3/8"A	TM.C....-3U TM.C-D...-3U or 3A		SN3T	5-40UNCx8.8	HK3T			T10
1/2"U	TM.C....-4U TM.C-D...-4U		SA4T	8-32UNCx14.0	HK4T			T20
5.0L	TM.C....-5L CTMC....-5L		SN5LTR	M2.2X0.45X5.0	K7T			T7
3/8"L	TM.C....-3 CTMC....-3L		SN3T SA3T	5-40UNCx8.8 5-40UNCx11.3	HK3T			T10
5/8"V	TM.SC-D...-5V..		SA5T	M5x0.8x22.0	HK5T			T25
3/8"U	TM4SC D169-050-3U	1/4-28x1.25	SN3T	5-40UNCx8.8	HK3T			T10
	TM5SC D208-075-3U	3/8-24x1.25						
1/2"U	TM6SC D346-100-4U	1/2-20x1.5	SA4T	8-32UNCx14.0	HK4T			T20
	TM8SC D435-150-4U	3/4-16x1.75						
3/8"L	TM7SC-D315-125-3L	5/8-18UNx11/2	SA3T	5-40UNCx11.3	HK3T			T10
	TM6SC-D228-075-3L-ABUT	3/8-24x1.25						
5/8"V	TM6SC D346-125-5V6-ABUT	5/8-18UNx11/2	SA5T	M5x0.8x22.0	HK5T			T25
	TM6SC D346-125-5V8-ABUT							

Troubleshooting

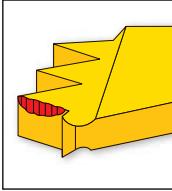
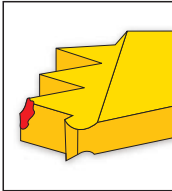
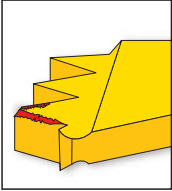
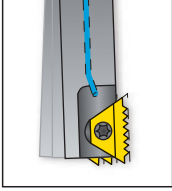
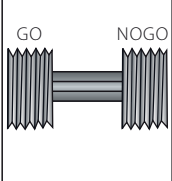
Image	Problem	Possible Cause	Solution
	Increased insert flank wear	Cutting speed too high -----> Chip is too thin -----> Insufficient coolant ----->	Reduce cutting speed/use coated insert Increase feed rate Increase coolant flow rate
	Chipping of cutting edge	Chip is too thick -----> Vibration ----->	Reduce feed rate Use the tangential arc method Increase RPM Check stability
	Material build up on the cutting edge	Incorrect cutting speed -----> Unsuitable carbide grade ----->	Change cutting speed Use a coated carbide grade
	Chatter / Vibration	Feed rate is too high -----> Profile is too deep -----> Thread length is too long ----->	Reduce the feed Execute two passes, each with increased cutting depth Execute two passes, each cutting only half the thread length Execute two passes, each cutting only half the thread length
	Insufficient thread accuracy	Tool deflection ----->	Reduce feed rate Execute a "zero" cut

The Thread Milling Handbook

The Thread Milling Handbook:

Your everyday guide to the theory and implementation of the thread milling system.

Download at www.vargususa.com



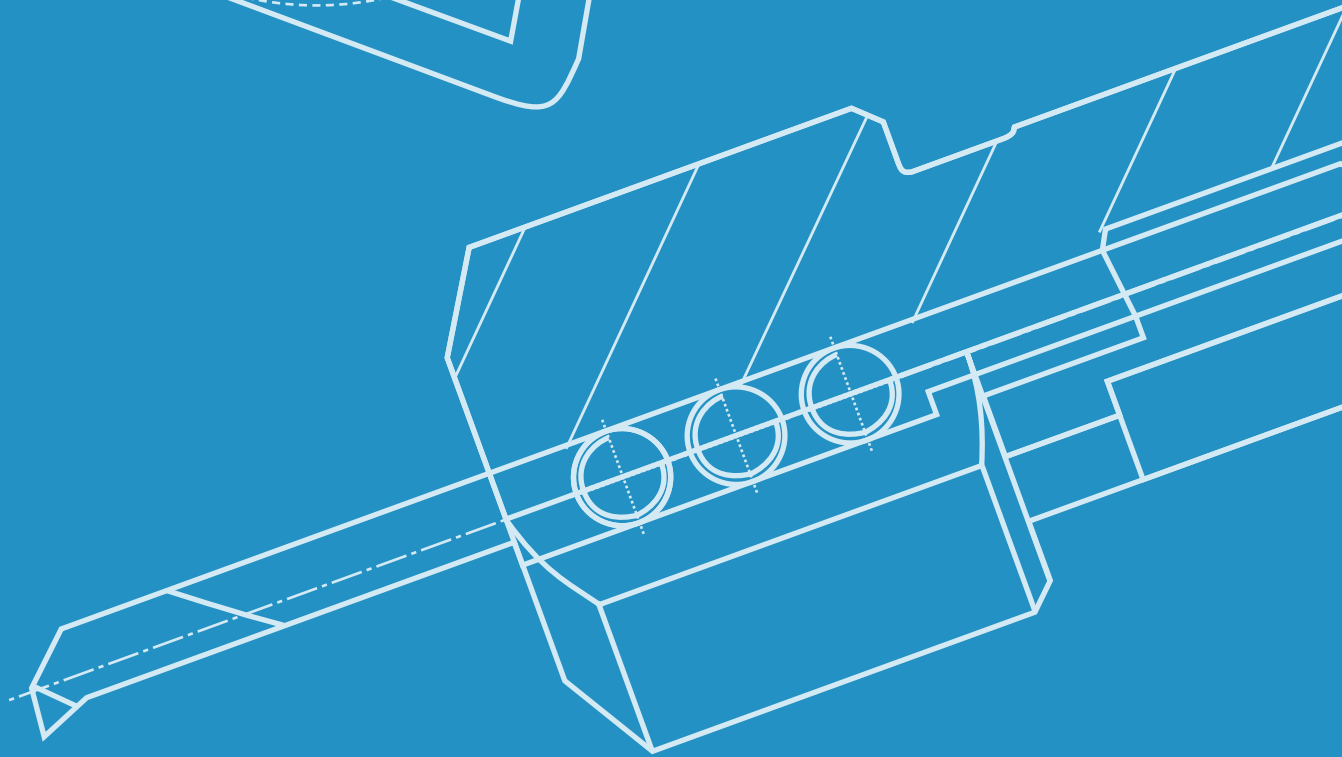
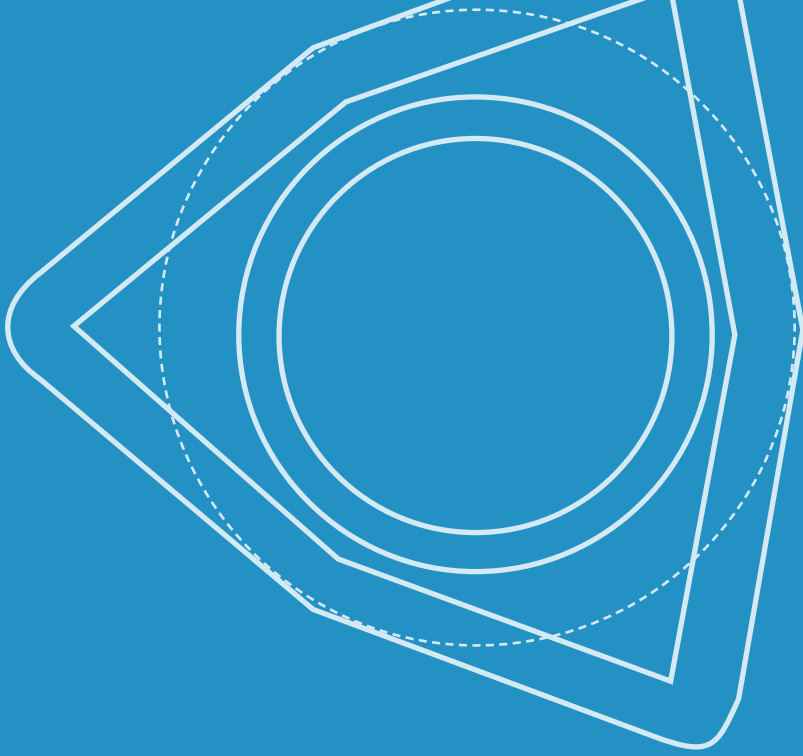

MINIPRO

■	PowerBore Inserts	381
■	Micro (Boring & Grooving) Inserts	383
■	Toolholders (PowerBore & Micro)	395
■	Technical Data	403

Vardex Ordering Code System

■ PowerBore Inserts

T 1	D 2	0 3	W 4	41 5	14 6	VTX 7
1 - Insert Shape C - Diamond 80 deg. T - Triangle W - Trigon 80 deg.	2 - Clearance Angle C - 7 deg. D - 15 deg.	3 - Tolerance Class 0 - Special Tolerance Class		4 - Insert Type W - Hole + Countersink		
5 - Insert Dimension 40 - IC .156" - Thickness-.040" 41 - IC .160" - Thickness-.047" 42 - IC .156" - Thickness-.062" 50 - IC .187" - Thickness-.096"	6 - Corner Radius 11 - R.002 12 - R.007 13 - R.008 14 - R.015	7 - Carbide Grade VTX				

■ Micro Boring Inserts - Double Ended

6.0 1	S 2	I 3	R 4	0.2 5	M 6	-	Bore 7	-	1 8	VMX 9
1 - Insert Dia. 3.0 - 3.0mm 4.0 - 4.0mm 6.0 - 6.0mm 8.0 - 8.0mm 10.0 - 10.0mm	2 - Insert Style S - Micro Insert		3 - Type of Insert I - Internal		4 - RH or LH R - Right Hand Insert L - Left Hand Insert		5 - Corner Radius (mm) 0.2			
6 - Tool Length U - Ultra Short S - Short M - Medium L - Long	7 - Tool Application Bore - Boring Copy - Boring Copy Chamfer - Boring Chamfer Back - Back Edge 3527, 3537, 3547 - Long Nose BD - Bore Drill			8 - Front Relief 1 - With Relief 0 - Without Relief		9 - Carbide Grade VMX				

■ Micro Grooving Inserts - Double Ended

4.0 1	S 2	I 3	R 4	090 5	S 6	-	D472 7	-	1.1 8	VMX 9
1 - Insert Dia. 3.0 - 3.0 mm 4.0 - 4.0 mm 6.0 - 6.0 mm 8.0 - 8.0 mm 10.0 - 10.0 mm	2 - Insert Style S - Micro Insert		3 - Type of Insert I - Internal		4 - RH / LH Insert R - Right Hand Insert L - Left Hand Insert		5 - Groove Std. Width .027 - .078 (inch) 0.90 - 2.15 (mm)			
6 - Insert Length A - Axially S - Short M - Medium L - Long	7 - Groove Standard DIN 471 DIN 472 CIRCLIP DIN 7993 DIN 765H, DIN 765T DIN 3770S, DIN 3770D SNAP RING CIRCLIP - Face Grooving			8 - Groove Depth .02" - .06"		9 - Carbide Grade VMX				

Internal

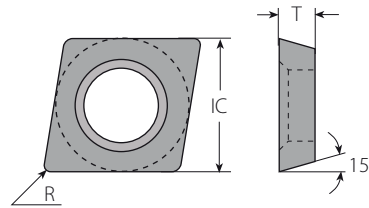
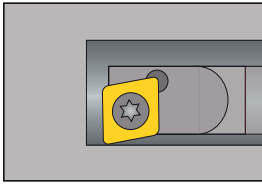

CD0W

CD0W Inserts

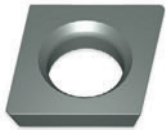

Insert Size	Ordering Code	Dimensions Inch	
		R	T
.156"	CD0W4011...	.002	.040
	CD0W4012...	.007	.040
	CD0W4014...	.015	.040

Spare Parts

Insert Screw



VS01

Internal

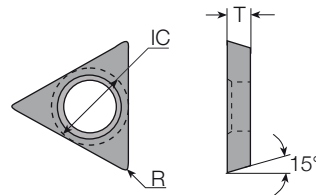
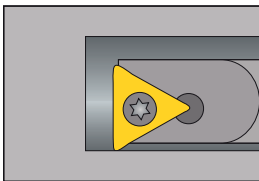

TD0W

TD0W Inserts

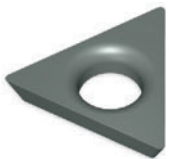

Insert Size	Ordering Code	Dimensions Inch	
		R	T
.160"	TD0W4111...	.002	.047
	TD0W4112...	.007	.047
	TD0W4114...	.015	.047

Spare Parts

Insert Screw



VS01, VS40

Boring

Internal



WCOW 4213, 4214

WCOW Inserts

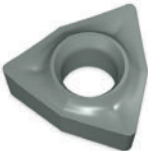

Insert Size	Ordering Code	Dimensions Inch		Spare Parts
		R	T	
.156"	WCOW4213...	.008	.062	Insert Screw  VS40
	WCOW4214...	.015	.062	

Internal



WCOW 5013, 5014

WCOW Inserts

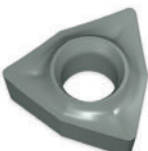

Insert Size	Ordering Code	Dimensions Inch		Spare Parts
		R	T	
.187"	WCOW5013...	.008	.096	Insert Screw  VS41
	WCOW5014...	.015	.096	

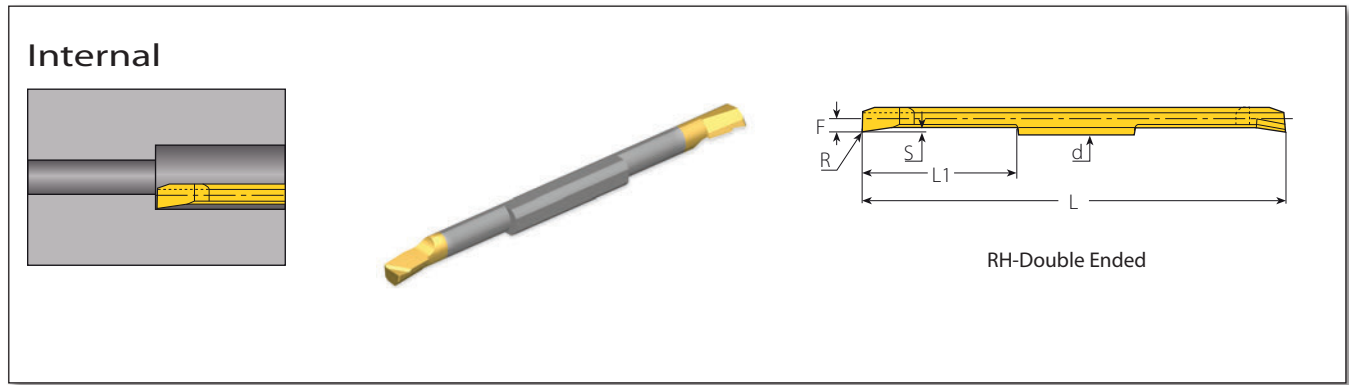

Micro - Double Ended

Insert Dia.	Ordering Code	Dimensions Inch					Min. Bore Dia.	Toolholder
d mm	RH	R	L1	L	S	F	Inch	
3.0	3.0SIR0.1U-Bore-1...	.004	.24	1.417	.022	.054	.126	SMC..-3.0
	3.0SIR0.1S-Bore-1...	.004	.35	1.417	.022	.054		
	3.0SIR0.2S-Bore-1...	.008	.35	1.417	.026	.056		
	3.0SIR0.2M-Bore-1...	.008	.63	1.969	.026	.056		
4.0	4.0SIR0.2S-Bore-1...	.008	.35	1.417	.026	.076	.165	SMC..-4.0
	4.0SIR0.2M-Bore-1...	.008	.63	1.969	.026	.076		
	4.0SIR0.2L-Bore-1...	.008	.83	2.362	.026	.076		
6.0	6.0SIR0.2S-Bore-1...	.008	.35	1.417	.030	.115	.244	SMC..-6.0
	6.0SIR0.2M-Bore-1...	.008	.63	1.969	.030	.115		
	6.0SIR0.2L-Bore-1...	.008	.83	2.362	.030	.115		
8.0	8.0SIR0.2S-Bore-1...	.008	.47	2.126	.032	.154	.323	SMC..-8.0
	8.0SIR0.2M-Bore-1...	.008	.79	2.756	.032	.154		
	8.0SIR0.2L-Bore-1...	.008	1.10	3.386	.032	.154		
10.0	10.0SIR0.2S-Bore-1...	.008	.59	2.362	.039	.194	.402	SMC..-10.0
	10.0SIR0.2M-Bore-1...	.008	.98	3.150	.039	.194		
	10.0SIR0.2L-Bore-1...	.008	1.38	3.937	.039	.194		

Internal

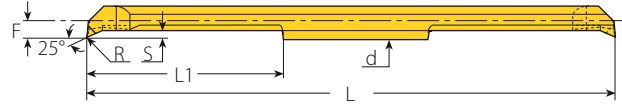
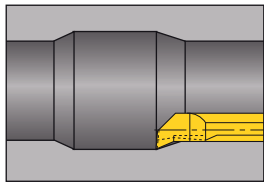

RH-Double Ended

Micro - Double Ended

Insert Dia.	Ordering Code	Dimensions Inch					Min. Bore Dia.	Toolholder
d mm	RH	R	L1	L	S	F	Inch	
4.0	4.0SIR0.2S-Copy-1...	.008	.35	1.417	.039	.076	.165	SMC...-4.0
	4.0SIR0.2M-Copy-1...	.008	.63	1.969	.039	.076		
	4.0SIR0.2L-Copy-1...	.008	.83	2.362	.039	.076		
6.0	6.0SIR0.2S-Copy-1...	.008	.35	1.417	.051	.115	.276	SMC...-6.0
	6.0SIR0.2M-Copy-1...	.008	.63	1.969	.051	.115		
	6.0SIR0.2L-Copy-1...	.008	.83	2.362	.051	.115		

Micro Boring - Chamfer

Internal

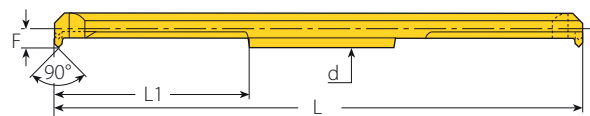
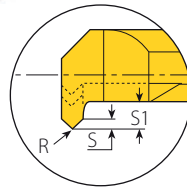
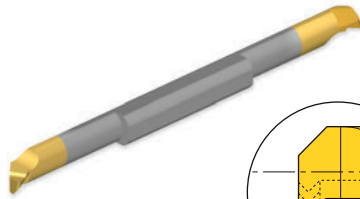
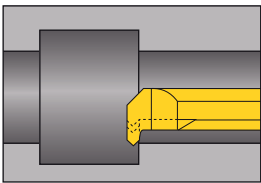

RH-Double Ended

Micro - Double Ended

Insert Dia.	Ordering Code	Dimensions Inch					Min. Bore Dia.	Toolholder	
d mm	RH	R	L1	L	F	S1	S	mm	
4.0	4.0SIR0.2S-Chamfer-0...	.008	.35	1.417	.076	.039	.016	.165	SMC...-4.0
	4.0SIR0.2M-Chamfer-0...	.008	.63	1.969	.076	.039	.016		
	4.0SIR0.2L-Chamfer-0...	.008	.83	2.362	.076	.039	.016		
6.0	6.0SIR0.2S-Chamfer-0...	.008	.35	1.417	.115	.047	.028	.244	SMC...-6.0
	6.0SIR0.2M-Chamfer-0...	.008	.63	1.969	.115	.047	.028		
	6.0SIR0.2L-Chamfer-0...	.008	.83	2.362	.115	.047	.028		

Boring & Grooving Inserts

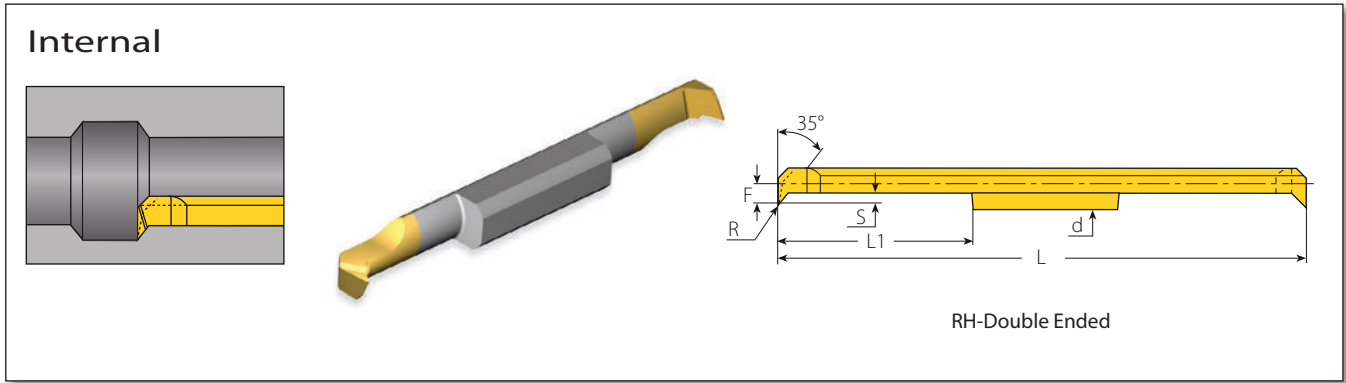

Micro - Double Ended

Insert Dia.	Ordering Code	Dimensions Inch					Min. Bore Dia.	Toolholder
d mm	RH	R	L1	L	S	F	Inch	
6.0	6.0SIR0.2S-3527-1...	.008	.35	1.417	.106	.115	.272	SMC...-6.0
	6.0SIR0.2M-3527-1...	.008	.63	1.969	.106	.115		
	6.0SIR0.2L-3527-1...	.008	.83	2.362	.106	.115		
8.0	8.0SIR0.2S-3537-1...	.008	.47	2.126	.146	.154	.350	SMC...-8.0
	8.0SIR0.2M-3537-1...	.008	.79	2.756	.146	.154		
	8.0SIR0.2L-3537-1...	.008	1.10	3.386	.146	.154		
10.0	10.0SIR0.2S-3547-1...	.008	.59	2.362	.185	.194	.425	SMC...-10.0
	10.0SIR0.2M-3547-1...	.008	.98	3.150	.185	.194		
	10.0SIR0.2L-3547-1...	.008	1.38	3.937	.185	.194		

Micro Boring - Back Boring

MINIPRO

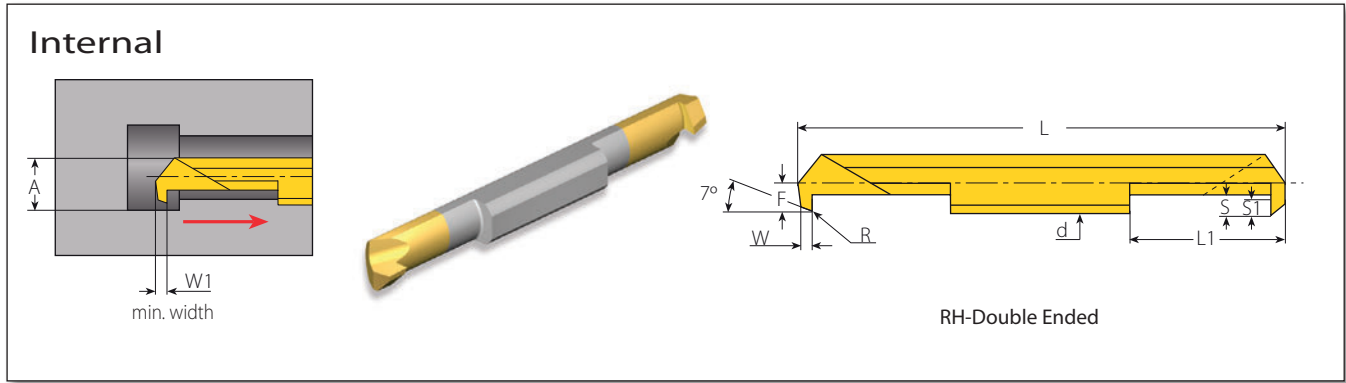

Micro - Double Ended

Insert Dia.	Ordering Code	Dimensions Inch										Min. Bore Dia.	Toolholder
d mm	RH	R	L1	L	A	W	W1	S	S1	F	Inch		
3.0	3.0SIR0.2S-Back-1...	.002	.35	1.417	.135	.059	.071	.031	.024	.056	.126	SMC...-3.0	
	3.0SIR0.2M-Back-1...	.002	.63	1.969									
4.0	4.0SIR0.2S-Back-1...	.002	.35	1.417	.175	.079	.092	.051	.039	.076	.165	SMC...-4.0	
	4.0SIR0.2M-Back-1...	.002	.63	1.969									
	4.0SIR0.2L-Back-1...	.002	.83	2.362									
6.0	6.0SIR0.2S-Back-1...	.002	.35	1.417	.254	.079	.097	.075	.063	.115	.244	SMC...-6.0	
	6.0SIR0.2M-Back-1...	.002	.63	1.969									
	6.0SIR0.2L-Back-1...	.002	.83	2.362									

Micro Boring - Bore Drill

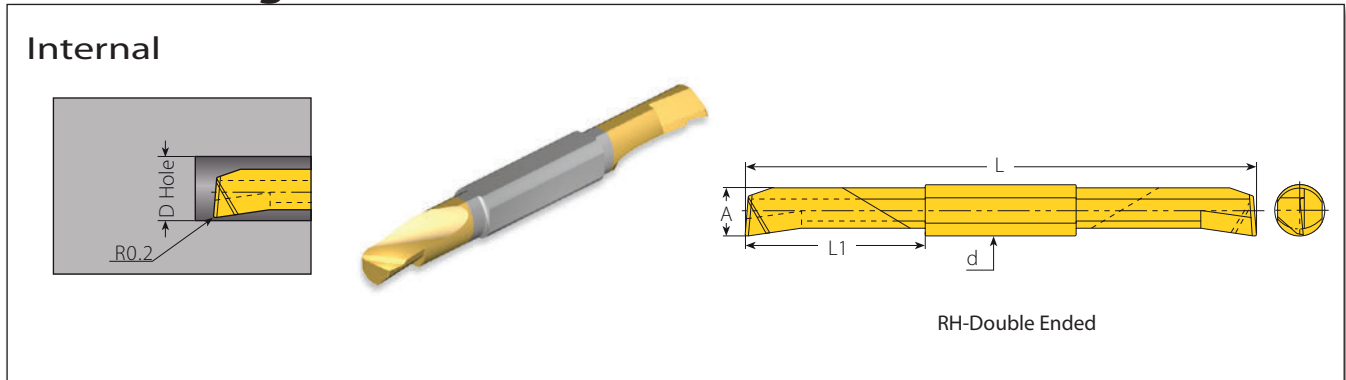

Micro - Double Ended

Insert Dia.	Ordering Code	Dimensions Inch				Min. Bore Dia.	Toolholder
d mm	RH	L1	L	A	Inch		
4.0	4.0SIR0.2M-BD-1...	.63	1.969	.139	.147	SMC...-4.0	
6.0	6.0SIR0.2M-BD-1...	.63	1.969	.205	.228	SMC...-6.0	
	6.0SIR0.2L-BD-1...	.83	2.362				
	8.0SIR0.2S-BD-1...	.47	2.126				
8.0	8.0SIR0.2M-BD-1...	.79	2.756	.272	.307	SMC...-8.0	
	8.0SIR0.2L-BD-1...	1.10	3.386				

Boring & Grooving Inserts

Internal

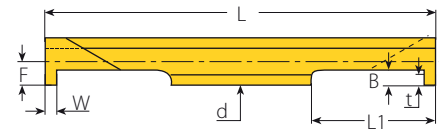
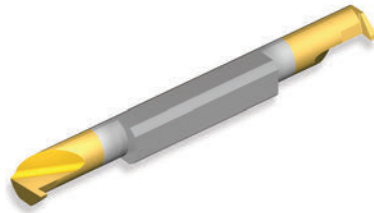
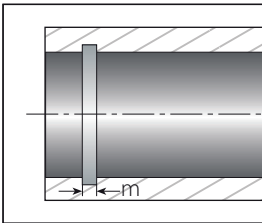

RH-Double Ended

Micro - Double Ended

Insert Dia.	Ordering Code	Groove Std.	Dimensions Inch						Min. Bore Dia.	Toolholder
d mm	RH	m (H13)	W	L1	L	B	t	F	Inch	
3.0	3.0SIR0.90S-D472-0.5...	.035	.039	.35	1.417	.031	.02	.055	.126	SMC...-3.0
	3.0SIR0.90M-D472-0.5...	.035	.039	.63	1.969					
	3.0SIR1.10S-D472-0.5...	.043	.047	.35	1.417					
	3.0SIR1.10M-D472-0.5...	.043	.047	.63	1.969					
4.0	4.0SIR0.90S-D472-1.1...	.035	.039	.35	1.417	.055	.043	.075	.161	SMC...-4.0
	4.0SIR0.90M-D472-1.1...	.035	.039	.63	1.969					
	4.0SIR0.90L-D472-1.1...	.035	.039	.83	2.362					
	4.0SIR1.10S-D472-1.1...	.043	.047	.35	1.417					
	4.0SIR1.10M-D472-1.1...	.043	.047	.63	1.969					
	4.0SIR1.10L-D472-1.1...	.043	.047	.83	2.362					
	4.0SIR1.30S-D472-1.1...	.051	.055	.35	1.417					
	4.0SIR1.30M-D472-1.1...	.051	.055	.63	1.969					
	4.0SIR1.30L-D472-1.1...	.051	.055	.83	2.362					
	4.0SIR1.60S-D472-1.1...	.063	.067	.35	1.417					
	4.0SIR1.60M-D472-1.1...	.063	.067	.63	1.969					
	4.0SIR1.60L-D472-1.1...	.063	.067	.83	2.362					
6.0	6.0SIR0.90S-D472-1.5...	.035	.039	.35	1.417	.071	.059	.114	.240	SMC...-6.0
	6.0SIR0.90M-D472-1.5...	.035	.039	.63	1.969					
	6.0SIR0.90L-D472-1.5...	.035	.039	.83	2.362					
	6.0SIR1.10S-D472-1.5...	.043	.047	.35	1.417					
	6.0SIR1.10M-D472-1.5...	.043	.047	.63	1.969					
	6.0SIR1.10L-D472-1.5...	.043	.047	.83	2.362					
	6.0SIR1.30S-D472-1.5...	.051	.055	.35	1.417					
	6.0SIR1.30M-D472-1.5...	.051	.055	.63	1.969					
	6.0SIR1.30L-D472-1.5...	.051	.055	.83	2.362					
	6.0SIR1.60S-D472-1.5...	.063	.067	.35	1.417					
	6.0SIR1.60M-D472-1.5...	.063	.067	.63	1.969					
	6.0SIR1.60L-D472-1.5...	.063	.067	.83	2.362					
	6.0SIR1.85S-D472-1.5...	.073	.076	.35	1.417					
	6.0SIR1.85M-D472-1.5...	.073	.076	.63	1.969					
	6.0SIR1.85L-D472-1.5...	.073	.076	.83	2.362					
	6.0SIR2.15S-D472-1.5...	.085	.088	.35	1.417					
	6.0SIR2.15M-D472-1.5...	.085	.088	.63	1.969					
	6.0SIR2.15L-D472-1.5...	.085	.088	.83	2.362					

Internal

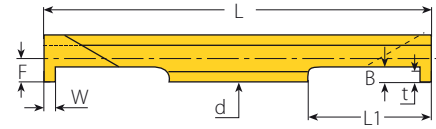
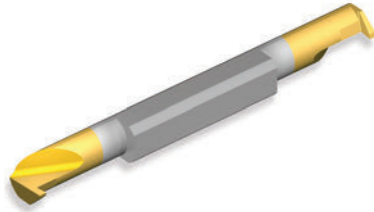
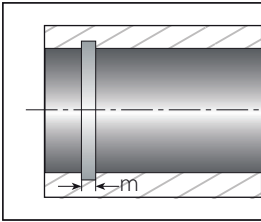

RH-Double Ended

Micro - Double Ended

Insert Dia.	Ordering Code	Groove Std.	Dimensions Inch					Min. Bore Dia.	Toolholder	
d mm	RH	m (H13)	W	L1	L	B	t	F	Inch	
8.0	8.0SIR1.10M-D472-2.0...	.043	.047	.79	2.76	.098	.079	.154	.331	SMC..-8.0
	8.0SIR1.30M-D472-2.0...	.051	.055	.79	2.76	.098	.079			
	8.0SIR1.60M-D472-2.5...	.063	.067	.79	2.76	.118	.098			
	8.0SIR1.85M-D472-2.5...	.073	.076	.79	2.76	.118	.098			
	8.0SIR2.15M-D472-3.0...	.085	.088	.79	2.76	.138	.118			
	8.0SIR2.65M-D472-3.5...	.104	.108	.79	2.76	.157	.138			
	8.0SIR3.15M-D472-3.5...	.124	.129	.79	2.76	.157	.138			
10.0	10.0SIR1.30M-D472-3.5...	.051	.055	.98	3.15	.157	.138	.193	.409	SMC..-10.0
	10.0SIR1.60M-D472-3.5...	.063	.067	.98	3.15					
	10.0SIR1.85M-D472-3.5...	.073	.076	.98	3.15					
	10.0SIR2.15M-D472-3.5...	.085	.088	.98	3.15					
	10.0SIR2.65M-D472-3.5...	.104	.108	.98	3.15					
	10.0SIR3.15M-D472-3.5...	.124	.129	.98	3.15					
	10.0SIR4.15M-D472-3.5...	.163	.169	.98	3.15					
10.0SIR5.15M-D472-3.5...	.203	.208	.98	3.15						

Internal

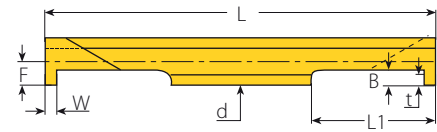
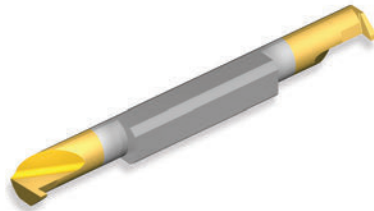
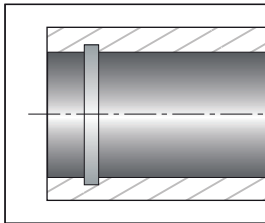

RH-Double Ended

Micro (Partial Profile)

Insert Dia. d mm	Ordering Code RH	Dimensions Inch					Min. Bore Dia. Inch	Toolholder	
		W	L1	L	B	t			
3.0	3.0SIR.027S-CIRC-.02...	.027	.35	1.42	.035	.023	.055	.126	SMC...-3.0
	3.0SIR.027M-CIRC-.02...	.027	.63	1.97					
	3.0SIR.031S-CIRC-.02...	.031	.35	1.42					
	3.0SIR.031M-CIRC-.02...	.031	.63	1.97					
	3.0SIR.041S-CIRC-.02...	.041	.35	1.42	.055	.043			
	3.0SIR.041M-CIRC-.02...	.041	.63	1.97					
	3.0SIR.046S-CIRC-.04...	.046	.35	1.42					
	3.0SIR.046M-CIRC-.04...	.046	.63	1.97					
4.0	4.0SIR.027S-CIRC-.04...	.027	.35	1.42	.055	.043	.074	.165	SMC...-4.0
	4.0SIR.027M-CIRC-.04...	.027	.63	1.97					
	4.0SIR.027L-CIRC-.04...	.027	.83	2.36					
	4.0SIR.031S-CIRC-.04...	.031	.35	1.42					
	4.0SIR.031M-CIRC-.04...	.031	.63	1.97					
	4.0SIR.031L-CIRC-.04...	.031	.83	2.36					
	4.0SIR.041S-CIRC-.04...	.041	.35	1.42					
	4.0SIR.041M-CIRC-.04...	.041	.63	1.97					
	4.0SIR.041L-CIRC-.04...	.041	.83	2.36					
	4.0SIR.047S-CIRC-.04...	.046	.35	1.42					
	4.0SIR.047M-CIRC-.04...	.046	.63	1.97					
	4.0SIR.047L-CIRC-.04...	.046	.83	2.36					
	4.0SIR.058S-CIRC-.04...	.058	.35	1.42	.071	.059			
	4.0SIR.058M-CIRC-.04...	.058	.63	1.97					
	4.0SIR.058L-CIRC-.04...	.058	.83	2.36					
	4.0SIR.062S-CIRC-.06...	.062	.35	1.42					
	4.0SIR.062M-CIRC-.06...	.062	.63	1.97					
	4.0SIR.062L-CIRC-.06...	.062	.83	2.36					
	4.0SIR.078S-CIRC-.06...	.078	.35	1.42					
	4.0SIR.078M-CIRC-.06...	.078	.63	1.97					
4.0SIR.078L-CIRC-.06...	.078	.83	2.36						

Internal

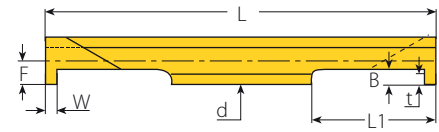
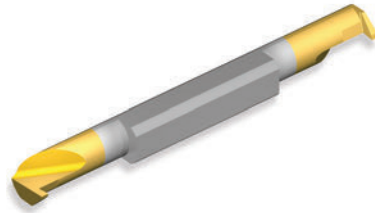
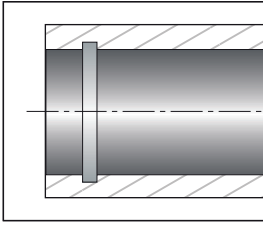

RH-Double Ended

Micro (Partial Profile)

Insert Dia.	Ordering Code	Dimensions Inch					Min. Bore Dia.	Toolholder	
d mm	RH	W	L1	L	B	t	F	Inch	
6.0	6.0SIR.046S-CIRC-.06...	.046	.35	1.42	.071	.059	.114	.244	SMC...-6.0
	6.0SIR.046M-CIRC-.06...	.046	.63	1.97					
	6.0SIR.046L-CIRC-.06...	.046	.83	2.36					
	6.0SIR.058S-CIRC-.06...	.058	.35	1.42					
	6.0SIR.058M-CIRC-.06...	.058	.63	1.97					
	6.0SIR.058L-CIRC-.06...	.058	.83	2.36					
	6.0SIR.062S-CIRC-.06...	.062	.35	1.42					
	6.0SIR.062M-CIRC-.06...	.062	.63	1.97					
	6.0SIR.062L-CIRC-.06...	.062	.83	2.36					
	6.0SIR.072S-CIRC-.06...	.072	.35	1.42					
	6.0SIR.072M-CIRC-.06...	.072	.63	1.97					
	6.0SIR.072L-CIRC-.06...	.072	.83	2.36					
	6.0SIR.078S-CIRC-.06...	.078	.35	1.42					
	6.0SIR.078M-CIRC-.06...	.078	.63	1.97					
	6.0SIR.078L-CIRC-.06...	.078	.83	2.36					
	6.0SIR.088S-CIRC-.06...	.088	.35	1.42					
	6.0SIR.088M-CIRC-.06...	.088	.63	1.97					
	6.0SIR.088L-CIRC-.06...	.088	.83	2.36					
	6.0SIR.094S-CIRC-.07...	.094	.35	1.42					
	6.0SIR.094M-CIRC-.07...	.094	.63	1.97					
6.0SIR.094L-CIRC-.07...	.094	.83	2.36						
6.0SIR.097S-CIRC-.07...	.097	.35	1.42						
6.0SIR.097M-CIRC-.07...	.097	.63	1.97						
6.0SIR.097L-CIRC-.07...	.097	.83	2.36						
6.0SIR.105S-CIRC-.07...	.105	.35	1.42						
6.0SIR.105M-CIRC-.07...	.105	.63	1.97						
6.0SIR.105L-CIRC-.07...	.105	.83	2.36						

Boring & Grooving Inserts

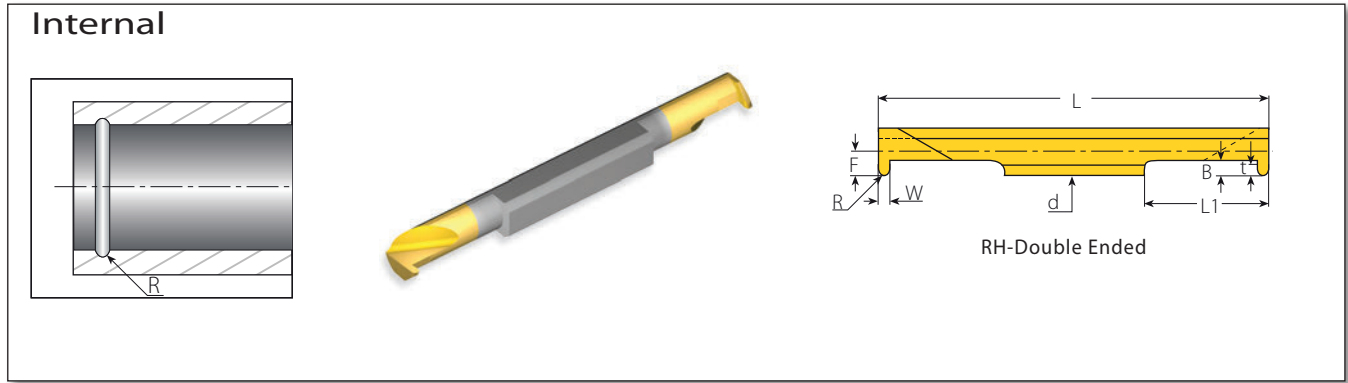

Micro (Partial Profile) - Double Ended

Insert Dia. d mm	Ordering Code RH	Groove Std. m (H13)	Dimensions Inch						Min. Bore Dia. Inch	Toolholder
			W	L1	L	B	t	F		
3.0	3.0SIR0.4S-D7993-0.6...	.016	.031	.36	1.42	.031	.024	.055	.126	SMC...-3.0
	3.0SIR0.4M-D7993-0.6...	.016	.031	.64	1.97					
4.0	4.0SIR0.4S-D7993-0.6...	.016	.031	.36	1.42	.035	.024	.075	.161	SMC...-4.0
	4.0SIR0.4M-D7993-0.6...	.016	.031	.64	1.97					
	4.0SIR0.4L-D7993-0.8...	.016	.031	.84	2.36					
	4.0SIR0.6S-D7993-0.8...	.024	.047	.36	1.42					
	4.0SIR0.6M-D7993-0.8...	.024	.047	.64	1.97	.043	.031			
	4.0SIR0.6L-D7993-0.8...	.024	.047	.84	2.36					
	4.0SIR0.9S-D7993-1.1...	.035	.071	.36	1.42					
	4.0SIR0.9M-D7993-1.1...	.035	.071	.64	1.97	.055	.043			
4.0SIR0.9L-D7993-1.1...	.035	.071	.84	2.36						
6.0	6.0SIR0.9S-D7993-1.1...	.035	.071	.36	1.42	.055	.043	.114	.24	SMC...-6.0
	6.0SIR0.9M-D7993-1.1...	.035	.071	.64	1.97					
	6.0SIR0.9L-D7993-1.1...	.035	.071	.84	2.36					
	6.0SIR1.0S-D7993-1.2...	.039	.079	.36	1.42	.059	.047			
	6.0SIR1.0M-D7993-1.2...	.039	.079	.64	1.97					
	6.0SIR1.0L-D7993-1.2...	.039	.079	.84	2.36					
	6.0SIR1.1S-D7993-1.3...	.043	.087	.36	1.42	.063	.051			
	6.0SIR1.1M-D7993-1.3...	.043	.087	.64	1.97					
6.0SIR1.1L-D7993-1.3...	.043	.087	.84	2.36						
8.0	8.0SIR0.9M-D7993-2.0...	.035	.071	.79	2.76	.098	.079	.154	.331	SMC...-8.0
	8.0SIR1.1M-D7993-2.0...	.043	.087	.79	2.76					
	8.0SIR1.4M-D7993-2.0...	.055	.110	.79	2.76					
10.0	10.0SIR1.4M-D7993-2.9...	.055	.110	.99	3.15	.134	.114	.193	.409	SMC...-10.0
	10.0SIR1.8M-D7993-2.9...	.071	.142	.99	3.15					

Snap Ring Grooves Inch Standard



Internal

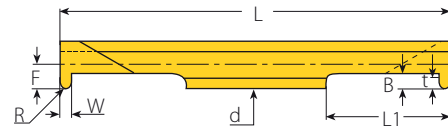
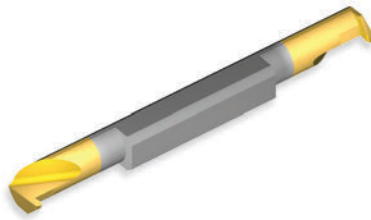
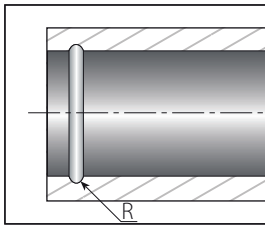

RH-Double Ended

Micro (Partial Profile) - Double Ended

Insert Dia. d mm	Ordering Code RH	Groove Std.			Dimensions Inch				Min. Bore Dia. Inch	Toolholder
		R	W	L1	L	B	t	F		
3.0	3.OSIR.015S-SNAP-.02...	.015	.030	.35	1.42	.035	.024	.055	.126	SMC...-3.0
	3.OSIR.015M-SNAP-.02...	.015	.030	.63	1.97					
4.0	4.OSIR.015S-SNAP-.02...	.015	.030	.35	1.42	.035	.024	.075	.161	SMC...-4.0
	4.OSIR.015M-SNAP-.02...	.015	.030	.63	1.97					
	4.OSIR.015L-SNAP-.02...	.015	.030	.83	2.36					
	4.OSIR.023S-SNAP-.03...	.023	.047	.35	1.42					
	4.OSIR.023M-SNAP-.03...	.023	.047	.63	1.97	.047	.035			
	4.OSIR.023L-SNAP-.03...	.023	.047	.83	2.36					
	4.OSIR.031S-SNAP-.05...	.031	.062	.35	1.42					
	4.OSIR.031M-SNAP-.05...	.031	.062	.63	1.97					
6.0	4.OSIR.031L-SNAP-.05...	.031	.062	.83	2.36	.063	.051	.114	.240	SMC...-6.0
	6.OSIR.031S-SNAP-.05...	.031	.062	.35	1.42					
	6.OSIR.031M-SNAP-.05...	.031	.062	.63	1.97					
	6.OSIR.031L-SNAP-.05...	.031	.062	.83	2.36					
	6.OSIR.036S-SNAP-.05...	.036	.072	.35	1.42					
	6.OSIR.036M-SNAP-.05...	.036	.072	.63	1.97					
	6.OSIR.036L-SNAP-.05...	.036	.072	.83	2.36					
	6.OSIR.039S-SNAP-.05...	.039	.078	.35	1.42					
	6.OSIR.039M-SNAP-.05...	.039	.078	.63	1.97					
	6.OSIR.039L-SNAP-.05...	.039	.078	.83	2.36					
	6.OSIR.047S-SNAP-.05...	.047	.094	.35	1.42					
	6.OSIR.047M-SNAP-.05...	.047	.094	.63	1.97					
6.OSIR.047L-SNAP-.05...	.047	.094	.83	2.36						
6.OSIR.062S-SNAP-.07...	.062	.125	.35	1.42	.079	.067				
6.OSIR.062M-SNAP-.07...	.062	.125	.63	1.97						
6.OSIR.062L-SNAP-.07...	.062	.125	.83	2.36						

Boring & Grooving Inserts

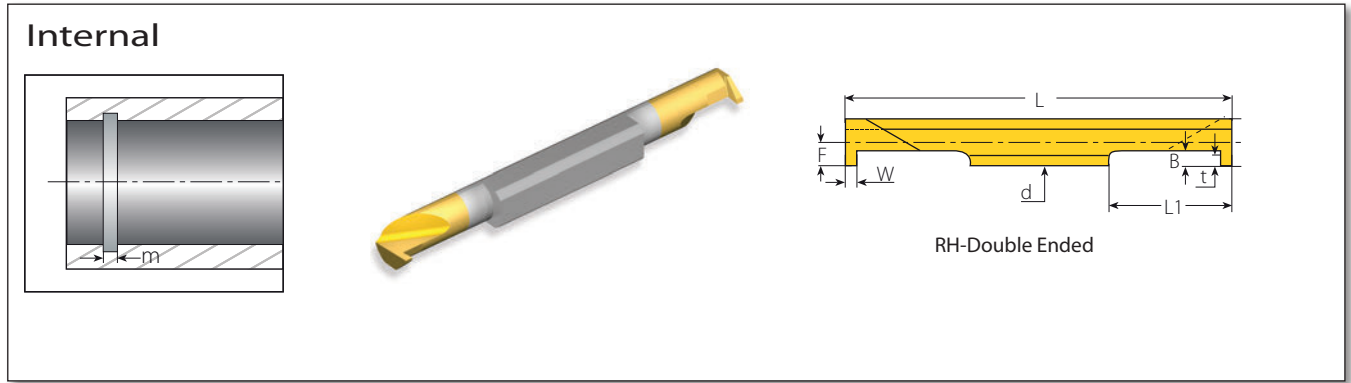

Micro - Double Ended

Insert Dia.	Ordering Code	Groove Std.	Dimensions Inch						Min. Bore Dia.	Toolholder
d mm	RH	m (H13)	W	L1	L	B	t	F	Inch	
6.0	6.0SIR1.6S-D3770S-1.5...	.063	.078	.35	1.42	.071	.059	.114	.24	SMC...-6.0
	6.0SIR1.6M-D3770S-1.5...	.063	.078	.63	1.97					
	6.0SIR1.6L-D3770S-1.5...	.063	.078	.83	2.36					
	6.0SIR2.0S-D3770D-1.8...	.079	.094	.35	1.42	.079	.071	.114		
	6.0SIR2.0M-D3770D-1.8...	.079	.094	.63	1.97					
	6.0SIR2.0L-D3770D-1.8...	.079	.094	.83	2.36					

CIRCLIP - Face Grooves

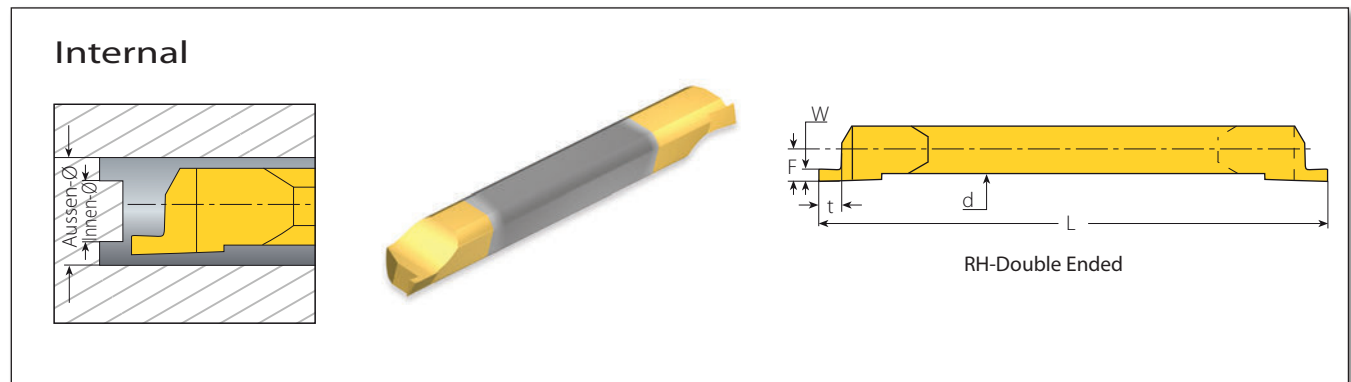

Micro (Partial Profile) - Double Ended

Insert Dia.	Ordering Code	Dimensions Inch					Inner Groove Ø	Outer Groove Ø
d mm	RH	W	t	L	F	Sleeve		
4.0	4.0SIR.031A-CIRC-.055...	.031	.043	1.969	.076	SMC...-4.0	.138	.198
	4.0SIR.041A-CIRC-.063...	.041	.051				.130	.212
	4.0SIR.047A-CIRC-.071...	.047	.059				.122	.216
	4.0SIR.058A-CIRC-.082...	.058	.075				.110	.226
	4.0SIR.062A-CIRC-.086...	.062	.083				.106	.230
6.0	6.0SIR.031A-CIRC-.055...	.031	.043	1.969	.126	SMC...-6.0	.216	.276
	6.0SIR.041A-CIRC-.063...	.041	.051				.209	.291
	6.0SIR.047A-CIRC-.071...	.047	.059				.200	.294
	6.0SIR.058A-CIRC-.082...	.058	.075				.189	.305
	6.0SIR.062A-CIRC-.086...	.062	.083				.185	.309
	6.0SIR.072A-CIRC-.094...	.072	.087				.177	.321
	6.0SIR.078A-CIRC-.088...	.078	.087				.169	.325
	6.0SIR.088A-CIRC-.110...	.088	.088				.161	.337

Boring & Grooving Inserts

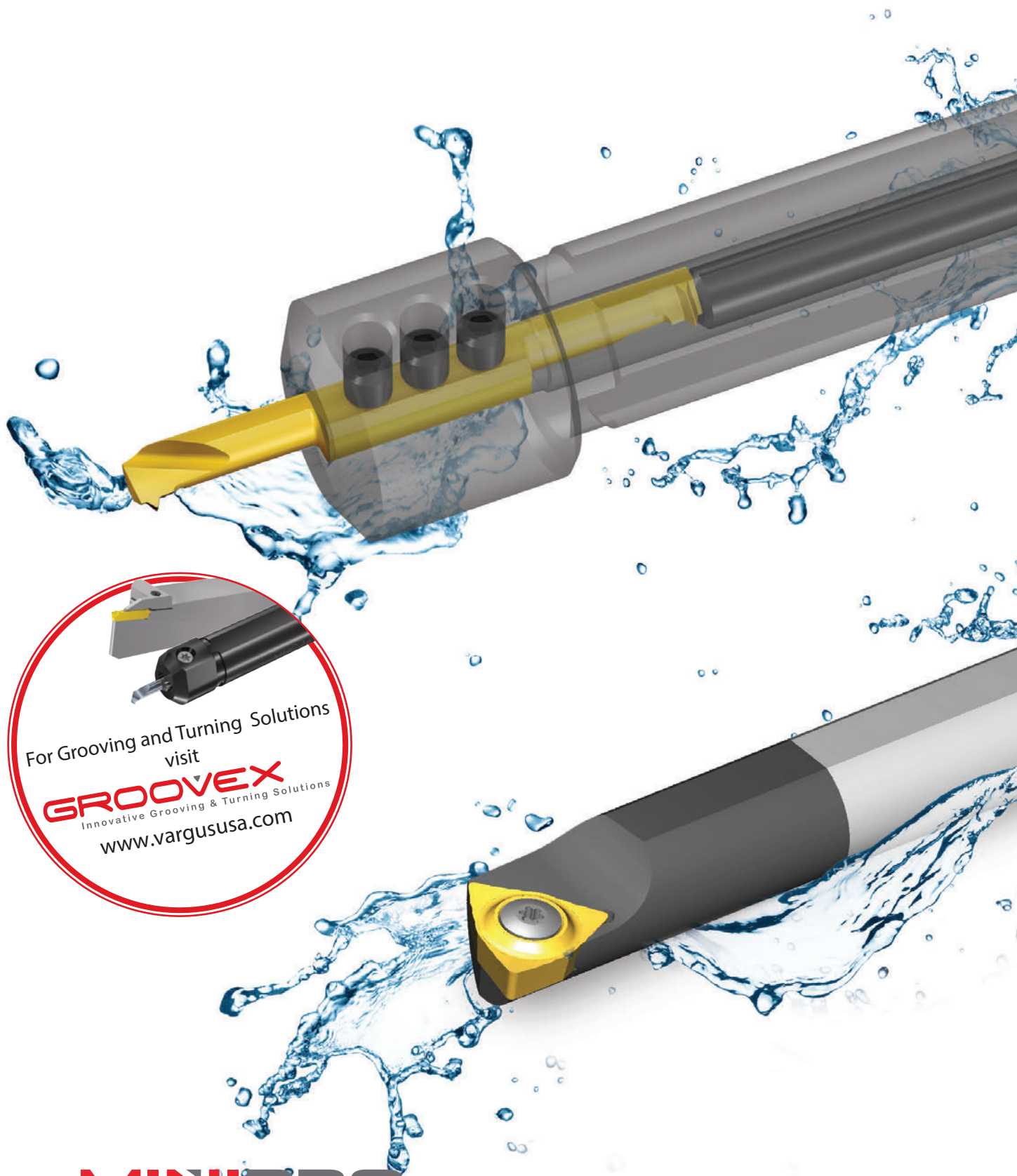

For Grooving and Turning Solutions
visit
GROOVEX
Innovative Grooving & Turning Solutions
www.vargususa.com



MINIPRO

MiniPro Toolholders

PowerBore Toolholders | Micro Toolholders

Vardex Ordering Code System

■ PowerBore Toolholders

C 1	06 2	-	23 3	C 4	40 5	5 6
1 - Shank Style C - Carbide S - Steel	2 - Shank Dia. 05 - 5/32" - .156 06 - 3/16" - .187 08 - 1/4" - .250 10 - 5/16" - .312 12 - 3/8" - .375 16 - 1/2" - .500	3 - Bar Dia. [D_i] 21 - .165 23 - .180 24 - .187 26 - .203 32 - .250 40 - .312	4 - Insert Shape C - Diamond 80 Deg.  T - Triangle  W - Trigon 80 Deg. 	5 - Holder Length [L₂] 23 - 2.25 25 - 2.50 27 - 2.75 30 - 3.00 35 - 3.50 40 - 4.00 45 - 4.50 50 - 5.00 60 - 6.00		6 - Front Relief Angle 0, 5, 7

■ Micro Toolholders (Sleeves)

S 1	M 2	C 3	0625 4	-	3 5
1 - Holder Shape S - Sleeve (Double Ended)	2 - Holder Type M - Micro (Double Ended)	3 - Cooling C - Coolant Channel	4 - Holder Dia. 050 - 1/2" 0625 - 5/8" 075 - 3/4"	5 - Bore Size Micro Size (mm) 3, 4, 6, 8, 10	

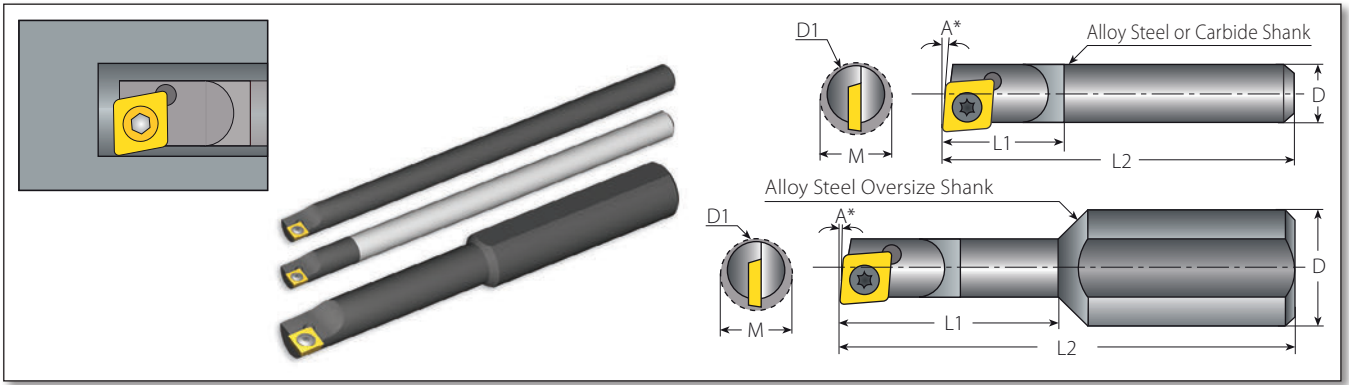

Alloy Steel Shanks - Standard Size

Shank	Ordering Code	EDP No.	Dimensions Inch					Spare Parts			
			A	D	D1	M	L2	L1	Insert Type	Screw	Torx Key
			Angle	Shank Dia.	Bar Dia.	Min. Bore	Overall Length	Bar Length			
3/16"	S06-21C257	41546	7°	.187	.165	.180	2.500	.500	CD0W	VS01	VT51
	S06-23C255	41547	5°	.187	.180	.208	2.500				
	S06-24C255	41548	5°	.187	.187	.230	2.500				
	S06-24C250	41543	0°	.187	.187	.244	2.500				
1/4"	S08-32C305	41550	5°	.250	.250	.290	3.000	D1=D			
	S08-32C300	41551	0°	.250	.250	.300	3.000				

Solid Carbide Shank - Standard Size

Shank	Ordering Code	EDP No.	Dimensions Inch					Spare Parts			
			A	D	D1	M	L2	L1	Insert Type	Screw	Torx Key
			Angle	Shank Dia.	Bar Dia.	Min. Bore	Overall Length	Bar Length			
5/32"	C05-21C607	41552	7°	.156	.165	.180	6.000	.500	CD0W	VS01	VT51
	C06-23C405	41553	5°	.187	.180	.208	4.000				
3/16"	C06-24C405	41554	5°	.187	.187	.230	4.000	D1=D			
		C06-24C400	41555	0°	.187	.187	.244				
1/4"	C08-32C405	41556	5°	.250	.250	.290	4.000	D1=D			
		C08-32C400	41557	0°	.250	.250	.300				

Alloy Steel Shanks - Oversize

Shank	Ordering Code	EDP No.	Dimensions Inch					Spare Parts			
			A	D	D1	M	L2	L1	Insert Type	Screw	Torx Key
			Angle	Shank Dia.	Bar Dia.	Min. Bore	Overall Length	Bar Length			
3/8"	S12-23C235	41558	5°	.375	.180	.208	2.250	1.000	CD0W	VS01	VT51
	S12-26C235	41559	5°	.375	.203	.230	2.250				
	S12-26C230	41560	0°	.375	.203	.244	2.250				
	S12-32C255	41561	5°	.375	.250	.290	2.500	1.250			
	S12-32C250	41562	0°	.375	.250	.300	2.500				

* 5° angle for facing and thru-hole boring.
 * 0° angle for thru-hole boring and boring to a shoulder.

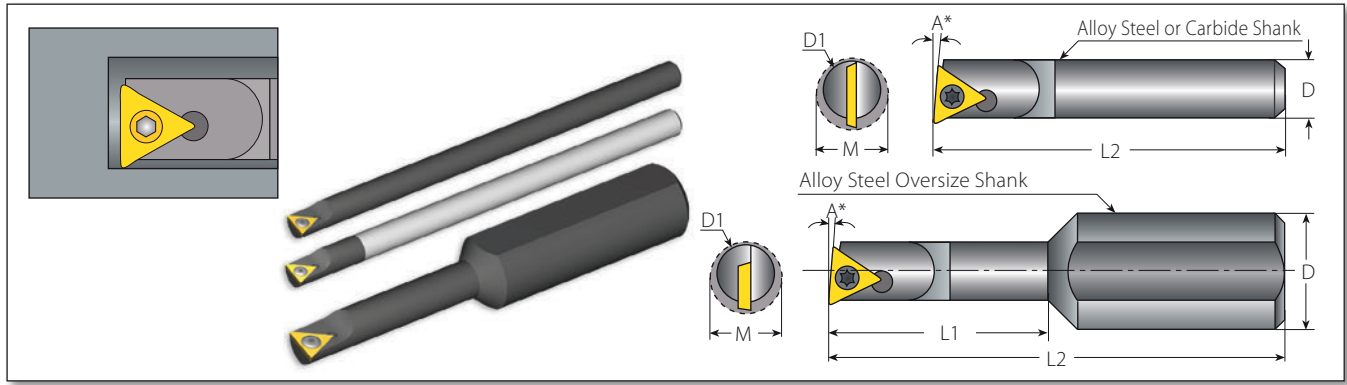

Alloy Steel Shanks - Standard Size

Spare Parts

Shank	Ordering Code	EDP No.	Dimensions Inch				Insert Type	Screw	Torx Key
			A	D=D1	M	L2			
			Angle	Bar Dia.	Min. Bore	Overall Length			
3/16"	S06-24T355	41563	5°	.187	.270	3.500	TD0W	VS01	VT51
	S06-24T350	41564	0°	.187	.270	3.500			
1/4"	S08-32T405	41565	5°	.250	.300	4.000		VS40	
	S08-32T400	41566	0°	.250	.300	4.000			
5/16"	S10-40T405	41567	5°	.312	.360	4.000			
	S10-40T400	41568	0°	.312	.360	4.000			

Solid Carbide Shank - Standard Size

Spare Parts

Shank	Ordering Code	EDP No.	Dimensions Inch				Insert Type	Screw	Torx Key
			A	D=D1	M	L2			
			Angle	Bar Dia.	Min. Bore	Overall Length			
3/16"	C06-24T405	41569	5°	.187	.270	4.000	TD0W	VS01	VT51
	C06-24T400	41570	0°	.187	.270	4.000			
1/4"	C08-32T405	41571	5°	.250	.300	4.000		VS40	
	C08-32T400	41572	0°	.250	.300	4.000			
5/16"	C10-40T405	41573	5°	.312	.360	4.000			
	C10-40T400	41574	0°	.312	.360	4.000			

Alloy Steel Shanks - Oversize

Spare Parts

Shank	Ordering Code	EDP No.	Dimensions Inch						Insert Type	Screw	Torx Key	
			A	D	D1	M	L2	L1				
			Angle	Shank Dia.	Bar Dia.	Min. Bore	Overall Length	Bar Length				
3/8"	S12-26T255	41575	5°	.375	.203	.270	2.500	1.000	TD0W	VS01	VT51	
	S12-26T250	41576	0°	.375	.203	.270	2.500					
	S12-32T275	41577	5°	.375	.250	.300	2.750			1.250		VS40
	S12-32T270	41578	0°	.375	.250	.300	2.750					
	S12-40T305	41579	5°	.375	.312	.360	3.000			1.500		VS40
	S12-40T300	41580	0°	.375	.312	.360	3.000					

* 5° angle for facing and thru-hole boring.
 * 0° angle for thru-hole boring and boring to a shoulder.

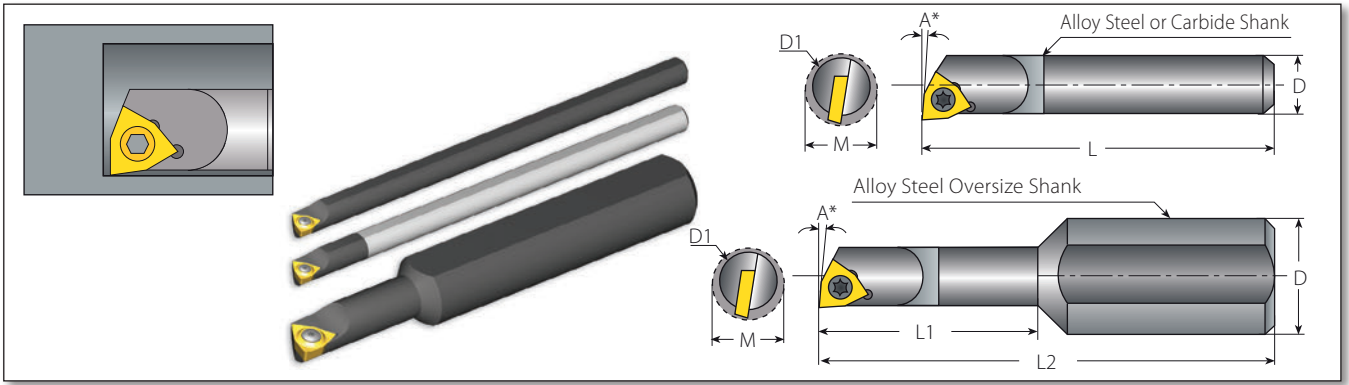

Alloy Steel Shanks - Standard Size

Shank	Ordering Code	EDP No.	Dimensions Inch				Spare Parts					
			A	D=D1	M	L	Insert Type	Screw	Torx Key			
			Angle	Bar Dia.	Min. Bore	Bar Length						
3/16"	S06-24W255	41581	5°	.187	.230	2.500	WCOW4213 WCOW4214	VS40	VT51			
	S06-24W250	41582	0°	.187	.244							
1/4"	S08-32W405	41583	5°	.250	.300	4.000						
	S08-32W400	41584	0°	.250	.300							

Solid Carbide Shank - Standard Size

Shank	Ordering Code	EDP No.	Dimensions Inch				Spare Parts					
			A	D=D1	M	L	Insert Type	Screw	Torx Key			
			Angle	Bar Dia.	Min. Bore	Bar Length						
3/16"	C06-24W405	41585	5°	.187	.230	4.000	WCOW4213 WCOW4214	VS40	VT51			
	C06-24W400	41586	0°	.187	.244							
1/4"	C08-32W405	41587	5°	.250	.290	4.000						
	C08-32W400	41588	0°	.250	.300							

Alloy Steel Shanks - Oversize

Shank	Ordering Code	EDP No.	Dimensions Inch						Spare Parts					
			A	D	D1	M	L2	L1	Insert Type	Screw	Torx Key			
			Angle	Shank Dia.	Bar Dia.	Min. Bore	Overall Length	Bar Length						
3/8"	S12-26W235	41589	5°	.375	.203	.230	2.250	.500	WCOW4213 WCOW4214	VS40	VT51			
	S12-26W230	41590	0°	.375	.203	.244	2.250							
	S12-32W255	41591	5°	.375	.250	.290	2.500	.750						
	S12-32W250	41592	0°	.375	.250	.300	2.500							

* 5° angle for facing and thru-hole boring.
 * 0° angle for thru-hole boring and boring to a shoulder.

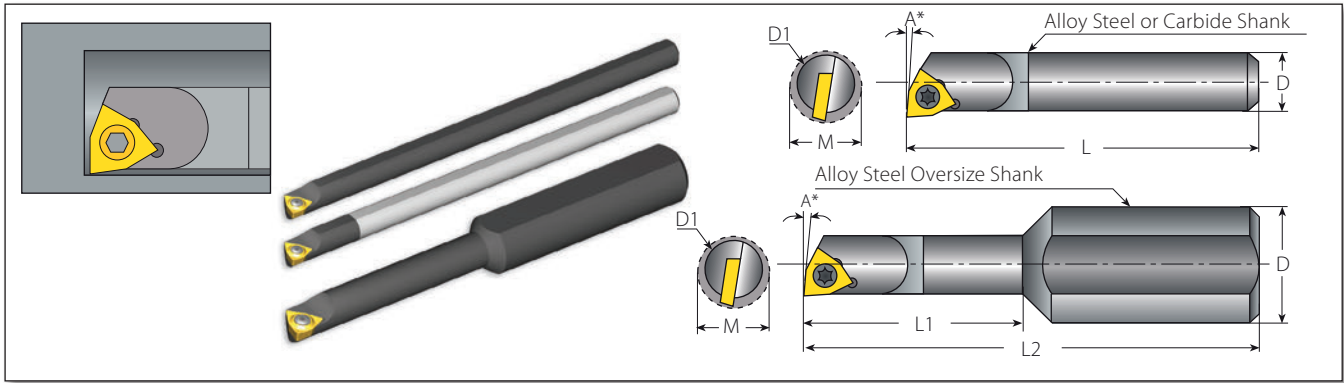

Alloy Steel Shanks - Standard Size

Spare Parts

Shank	Ordering Code	EDP No.	Dimensions Inch				Insert Type	Screw	Torx Key
			A	D=D1	M	L			
			Angle	Bar Dia.	Min. Bore	Bar Length			
5/16"	S10-40W405	41593	5°	.312	.360	4.000	WC0W5013	VS41	VT51
	S10-40W400	41594	0°	.312	.360		WC0W5014		



Solid Carbide Shank - Standard Size

Spare Parts

Shank	Ordering Code	EDP No.	Dimensions Inch				Insert Type	Screw	Torx Key
			A	D=D1	M	L			
			Angle	Bar Dia.	Min. Bore	Bar Length			
5/16"	C10-40W405	41597	5°	.312	.360	4.000	WC0W5013	VS41	VT51
	C10-40W400	41598	0°	.312	.360		WC0W5014		



Alloy Steel Shanks - Oversize

Spare Parts

Shank	Ordering Code	EDP No.	Dimensions Inch						Insert Type	Screw	Torx Key
			A	D	D1	M	L2	L1			
			Angle	Shank Dia.	Bar Dia.	Min. Bore	Overall Length	Bar Length			
3/8"	S12-40W305	41599	5°	.375	.312	.360	3.000	1.500	WC0W5013	VS41	VT51
	S12-40W300	41600	0°	.375	.312	.360	3.000		WC0W5014		



* 5° angle for facing and thru-hole boring.
 * 0° angle for thru-hole boring and boring to a shoulder.

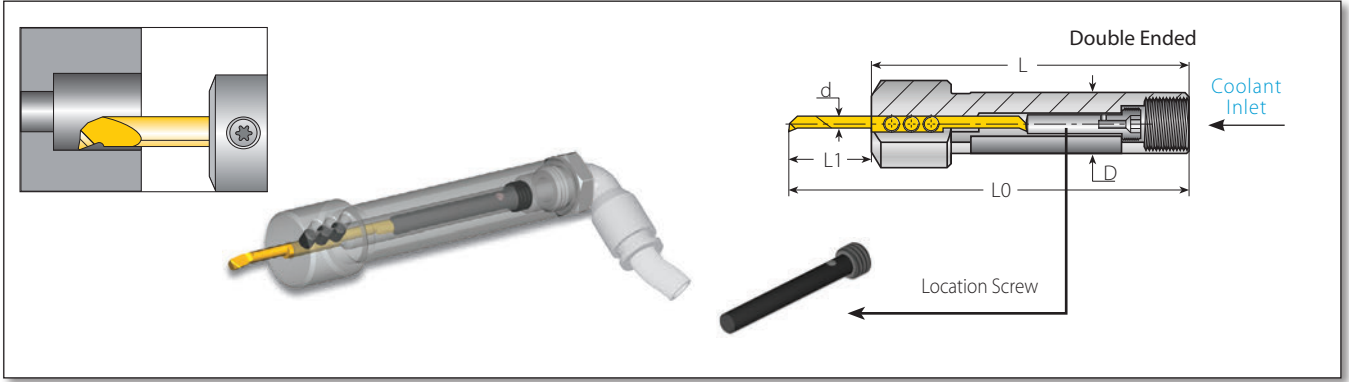

Spare Parts



Micro - Double Ended

Micro Insert Dia. d mm	Shank Dia. D	Ordering Code	EDP No.	Dimensions Inch			Location Screw*			Clamping Screw x 3	
				L	L1	L0	Screw	M	Key	Screw	Key
3	.50	SMC050-3.0	41075	3.15	.35 - Short	3.50	4GISM8X28	1.10	K4.0	M4X.7X4.0	K2.0
		SMC0625-3.0	40210		.63 - Medium	3.78	4GISM8X21	.83			
	SMC075-3.0	41080	3.74	.35 - Short	4.09	4GISM8X49	1.93				
.63 - Medium	4.37	4GISM8X42		1.65							
4	.50	SMC050-4.0	41092	3.15	.35 - Short	3.50	4GISM8X28	1.10			
		.63 - Medium	3.78		4GISM8X21	.83					
		.83 - Long	3.98		4GISM8X16	.63					
	.63	SMC0625-4.0	40212	3.74	.35 - Short	4.09	4GISM8X49	1.93			
		.63 - Medium	4.37		4GISM8X42	1.65					
.75	SMC075-4.0	41081		.83 - Long	4.57	4GISM8X37	1.46				
6	.50	SMC050-6.0	41517	3.15	.35 - Short	3.50	4GISM8X28	1.10			
		.63 - Medium	3.78		4GISM8X21	.83					
		.83 - Long	3.98		4GISM8X16	.63					
	.63	SMC0625-6.0	40214	3.74	.35 - Short	4.09	4GISM8X49	1.93			
		.63 - Medium	4.37		4GISM8X42	1.65					
.75	SMC075-6.0	41082		.83 - Long	4.57	4GISM8X37	1.46				
8	.63	SMC0625-8.0	40248	3.74	.47 - Short	4.21	4GISM8X33	1.30	M6X1.0X5.0	K3.0	
		.79 - Medium	4.53		4GISM8X25	.98					
	.75	SMC075-8.0	40184		1.10 - Long	4.84	4GISM8X17	.67			
10	.63	SMC0625-10.0	41093	3.74	.59 - Short	4.33	4GISM8X30	1.18			
		.98 - Medium	4.72		4GISM8X20	.79					
	.75	SMC075-10.0	41083		1.38 - Long	5.12	4GISM8X10	.39			

* Every toolholder package contains the full range of location screws needed.

40184
41093
41083



For Grooving and Turning Solutions
visit
GROOVEX
Innovative Grooving & Turning Solutions
www.vargususa.com

MINIPRO

MiniPro Technical Data

Recommended Grades, Cutting Speeds Vc [ft/min], Feed f [Inch/rev] and Max Depth [Inch]



Material Group	Vargus No.	Material	Hardness Brinell HB	Vc [ft/min]		Feed [Inch/rev]			Max Depth [Inch]			
				Coated		Power Bore	Micro Boring	Micro Grooving	PowerBore		Micro Boring	
				VTX (PowerBore)	VMX (Micro)				TDOW CDOW	WDOW		
P Steel	1	Unalloyed Steel	Low Carbon (C=0.1-0.25%)	125	377-623	164-394	.0098	.0020	.0012	.018	.024	.016
	2		Medium Carbon (C=0.25-0.55%)	150	328-574	131-328	.0079	.0016	.0008	.018	.024	.016
	3		High Carbon (C=0.55-0.85%)	170	295-541	98-262	.0059	.0012	.0004	.018	.024	.016
	4	Low Alloy Steel (alloying elements≤5%)	Non Hardened	180	279-476	164-230	.0079	.0016	.0008	.014	.020	.012
	5		Hardened	275	246-459	131-197	.0059	.0016	.0004	.014	.020	.012
	6	High Alloy Steel (alloying elements>5%)	Hardened	350	230-443	98-164	.0039	.0012	.0004	.014	.020	.012
	7		Annealed	200	230-361	98-164	.0039	.0016	.0008	.007	.016	.006
	8	Cast Steel	Hardened	325	164-328	82-131	.0020	.0012	.0004	.007	.016	.006
	9		Low Alloy (alloying elements<5%)	200	246-459	98-164	.0098	.0016	.0008	.007	.016	.006
	10	High Alloy (alloying elements>5%)	High Alloy (alloying elements>5%)	225	197-394	82-131	.0039	.0016	.0008	.007	.016	.006
11	Stainless Steel Ferritic		Non Hardened	200	230-427	197-328	.0079	.0016	.0004	.009	.020	.008
12		Hardened	330	197-377	131-197	.0031	.0012	.0004	.007	.016	.006	
M Stainless Steel	13	Stainless Steel Austenitic	Austenitic	180	295-459	164-295	.0079	.0016	.0004	.009	.020	.008
	14		Super Austenitic	200	131-361	131-197	.0031	.0016	.0004	.007	.016	.006
	15	Stainless Steel Cast Ferritic	Non Hardened	200	295-394	131-197	.0079	.0016	.0008	.009	.020	.008
	16		Hardened	330	213-361	98-164	.0031	.0012	.0004	.007	.016	.006
	17	Stainless Steel Cast Austenitic	Austenitic	200	279-361	131-197	.0079	.0016	.0008	.009	.020	.008
	18		Hardened	330	197-328	98-164	.0031	.0012	.0004	.007	.016	.006
K Cast Iron	28	Malleable Cast Iron	Ferritic (short chips)	130	230-525	164-230	.0059	.0008	.0008	.012	.016	.010
	29		Pearlitic (long chips)	230	197-476	164-230	.0039	.0004	.0004	.012	.016	.010
	30	Grey Cast Iron	Low Tensile Strength	180	230-427	164-230	.0059	.0008	.0008	.018	.024	.016
	31		High Tensile Strength	260	197-377	131-197	.0039	.0004	.0059	.018	.024	.016
	32	Nodular Sg Iron	Ferritic	160	410-525	164-230	.0059	.0008	.0008	.018	.024	.016
33	Pearlitic		260	295-394	197-262	.0039	.0004	.0004	.018	.024	.016	
N Non-Ferrous Metals	34	Aluminium Alloys Wrought	Non Aging	60	328-1,198	328-984	.0118	.0012	.0012	.025	.039	.020
	35		Aged	100	262-722	328-492	.0079	.0012	.0012	.025	.039	.020
	36	Aluminium Alloys	Cast	75	656-1,312	328-492	.0118	.0012	.0012	.025	.039	.020
	37		Cast & Aged	90	656-919	197-328	.0079	.0012	.0012	.025	.039	.020
	38	Aluminium Alloys	Cast Si 13-22%	130	197-591	328-492	.0118	.0008	.0008	.025	.039	.020
	39	Copper and Copper Alloys	Brass	90	262-738	197-328	.0118	.0012	.0012	.025	.039	.020
40	Bronze And Non Leaded Copper		100	262-837	197-328	.0079	.0012	.0012	.025	.039	.020	
S Heat Resistant Material	19	High Temperature Alloys	Annealed (iron based)	200	148-197	82-148	.0079	.0016	.0004	.009	.020	.008
	20		Aged (iron based)	280	98-164	66-98	.0031	.0012	.0004	.007	.016	.006
	21		Annealed (nickel or cobalt based)	250	66-98	49-66	.0031	.0004	.0004	.007	.016	.006
	22		Aged (nickel or cobalt based)	350	49-82	33-49	.0020	.0004	.0004	.007	.016	.006
	23	Titanium Alloys	Pure 99.5 Ti	400Rm	459-558	197-328	.0020	.0008	.0008	.007	.016	.006
24	α+β Alloys		1050Rm	164-230	131-164	.0020	.0008	.0008	.007	.016	.006	
H Hardened Material	25	Extra Hard Steel	Hardened & Tempered	45-50HRc	148-213	66-148	.0008	.0004	.0004	.002	.008	.002
	26			51-55HRc	148-197	66-131	.0004	.0004	.0004	.002	.004	.002





Grades

VTX

General use carbide grade. TiAlN coated.

VMX

General use carbide grade for Micro inserts. TiN coated.

Spare Parts for PowerBore line						
Insert	Boring Bar	Insert	Torx Screw	Screw Description	Torx Key	Torx Size
	A	CD0W	VS01	1-72 Oval X .109LG.	VT51	T6
	B	TD0W Min. Bore .28 > Bore .28	VS01 VS40	1-72 Oval X .109LG. M2 X 0.4 X .152LG.		
	E	WC0W4213, WC0W4214	VS40	M2 X 0.4 X .152LG.		
	F	WC0W5013, WC0W5014	VS41	M2 X 0.4 X .193LG.		







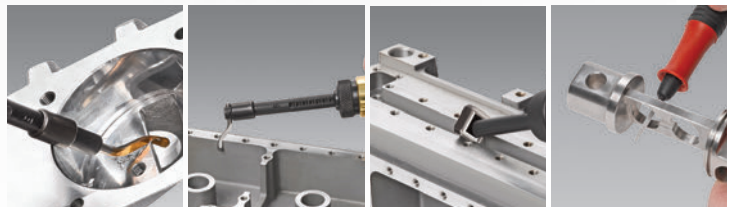

SHAVIV
Leading Deburring Solutions

The Finishing Touch



SHAVIV hand deburring tools offer a range of cost-effective and efficient solutions to companies across all industry sectors that need to remove burrs from different materials. The tools are renowned for providing “the finishing touch” in a host of applications, such as hole edges, straight edges, flat surfaces, keyways and corners.

- 
Die & Mold
- 
Electrical
- 
Plastic
- 
Automotive
- 
Metal
- 
Plumbing
- 
Aviation
- 
DIY

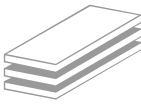
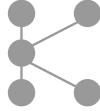
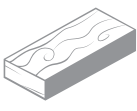
- 
Metal
- 
Aluminum
- 
Copper
- 
Cast Iron
- 
Plastic
- 
Wood



GROOVEX
Innovative Grooving & Turning Solutions

The increasingly popular and rapidly growing **GROOVEX** line, established in 2011, provides a comprehensive line of products for grooving, boring, turning and micro-machining solutions across all industry sectors.

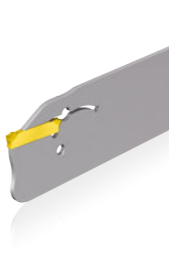

VG-Cut



microSCOPE



Mini-V

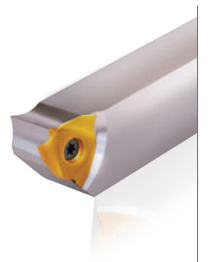

GrooVical

With a network of 13 international companies and hundreds of distributors, warehouses and certified ISO 9001 manufacturing facilities, VARGUS Ltd. serves customers in more than 100 countries around the globe. A customer-focused organization, VARGUS Ltd. is committed to providing innovative products and solutions of the highest quality and excellent value, and is renowned for its technical expertise and uncompromising service.



VARGUS Ltd. - Global Headquarters +972 4 9855 101 | mrktg@vargus.com

 **VARGUS USA** +1 800 828 8765 / 608 756 4930 | sales@vargususa.com

EUROPE

 **DENMARK**
VARGUS Scandinavia
+45 8794 4100
vargus@vargus.dk

 **FRANCE**
VARGUS France
+33 1 4601 7060
commercial@vargus.fr

 **GERMANY**
VARGUS Germany
+49 7043 36 161
info@vargus.de

 **ISRAEL**
NEUMO-VARGUS
+972 3 537 3275
neumo@neumo-vargus.co.il

 **POLAND**
VARGUS Poland
+48 46 834 9904 / 46 831 5140
vargus@neumo.pl

 **SPAIN**
VARGUS Ibérica
+34 977 52 49 00
sales@vargus.es

 **SWITZERLAND**
VARGUS Switzerland
+41 41784 2121
info@vargus.ch

 **TURKEY**
VARGUS Turkey
+90 212 875 01 41
info@vargusturkey.com

 **UNITED KINGDOM**
VARGUS Tooling UK
+44 1952 583 222
tooling.uk@vargustooling.co.uk

ASIA

 **CHINA**
VARGUS China
+86 21 516 88300
info@varguschina.net

 **INDIA**
VARGUS India
+91 2135 654748
info@vargusindia.com

LATIN AMERICA

 **BRAZIL**
VARGUS Brazil
+55 47 3084 8001
info@vargus.com.br



VARGUS GENiUS™ | Tool Selector and CNC Program Generator



The most popular and advanced thread turning and thread milling software on the market today.

Available in 4 versions at www.vargus.com

